

April 2012

Rehabilitative Robotic Glove

Carlos Humberto Martinez Luna
Worcester Polytechnic Institute

Michael Alfred Delph
Worcester Polytechnic Institute

Philip Walter Gauthier
Worcester Polytechnic Institute

Sarah Anne Fischer
Worcester Polytechnic Institute

Follow this and additional works at: <https://digitalcommons.wpi.edu/mqp-all>

Repository Citation

Martinez Luna, C. H., Delph, M. A., Gauthier, P. W., & Fischer, S. A. (2012). *Rehabilitative Robotic Glove*. Retrieved from <https://digitalcommons.wpi.edu/mqp-all/1841>

This Unrestricted is brought to you for free and open access by the Major Qualifying Projects at Digital WPI. It has been accepted for inclusion in Major Qualifying Projects (All Years) by an authorized administrator of Digital WPI. For more information, please contact digitalwpi@wpi.edu.



Rehabilitative Robotic Glove

Major Qualifying Project Report:

Submitted to the Faculty of



In partial fulfillment of the requirements for the
Degree of Bachelor of Science

In association with



By

Michael A. Delph II RBE

Sarah A. Fischer ECE/RBE

Philip W. Gauthier ME

Carlos H. Martinez Luna BME

2012
GSF-M121

Prof. Gregory S. Fischer Advisor

Prof. Edward A. Clancy Co-Advisor

Table of Contents

Abstract.....	1
Executive Summary.....	2
I. Background	2
II. Design.....	2
III. Results.....	4
A. Glove & Guides	4
B. Cable System.....	4
C. Servo Actuation & Spools.....	4
D. EMG Control	4
IV. Discussion	6
1. Introduction	8
2. Background	10
2.1. Hand Weakness.....	10
2.2. Rehabilitation Methods	10
2.2.1. Assistive and Resistive Exercise	11
2.3. Robotic Rehabilitative and Assistive Devices.....	11
2.4. Existing Glove Devices.....	13
2.5. Biomechanics of the Hand	14
2.6. Electromyogram Acquisition.....	15
3. Project Strategy.....	17
3.1. Client Statement	17
3.2. Objectives and Constraints	17
3.2.1. Primary Objectives	18
3.2.2. Project Constraints.....	18
3.3. Project Approach	19
3.3.1. Research.....	19
3.3.2. Design Phase	19
3.3.3. Prototyping and Testing.....	19

3.3.4. Design Finalization	20
4. Design Alternatives	21
4.1. Alternative Actuation.....	21
4.1.1. Springs and Elastics	21
4.1.2. Cable Drive	22
4.1.3. Motors.....	22
4.1.4. Pneumatics and Hydraulics	22
4.1.5. RC Servomotors.....	23
4.2. Cable-Spring Glove.....	23
4.3. Cable-Spool Glove	24
5. Final Design	25
5.1. Mechanical Subsystem.....	26
5.1.1. Proof of Concept	27
5.1.2. Glove Design	28
5.1.3. Cable Guides	28
5.1.4. Cable Selection.....	29
5.1.5. Bowden Cables.....	31
5.1.6. Cable Displacement	32
5.1.7. Spools.....	32
5.1.8. Quick Release Mechanism	36
5.1.9. Forearm Cable Guide	38
5.1.10. Servomotors.....	39
5.2. Electrical Subsystem	40
5.2.1. Myoelectric Control Signal Conditioning	41
5.2.2. Servomotor Current Limiting Circuit.....	44
5.2.3. Microcontroller	45
5.3. Software	46
5.3.1 Pulse-width Modulation	47
5.3.2. Digital Filters	48
6. Results & Discussion	49
6.1. Specifications	50
6.1.1. Grip Force.....	50

6.1.2. Battery Life	51
6.2. Safety	51
6.3. Electromyogram Control Calibration	52
6.4. Pre-tensioning.....	53
7. Future Work	54
7.1. Assistive Applications.....	54
7.2. Shape Deposition Glove.....	54
7.3. Dynamic Tension.....	55
7.4. Servomotor Casing.....	55
7.5. Accessibility.....	56
7.6. Mimic Glove	56
7.7. Functional MRI	57
8. Conclusion.....	58
Works Cited.....	59
Appendix A: List of Acronyms	61
Appendix B: Work Breakdown Structure	62
Appendix C: Gantt Chart Excerpt	63
Appendix D: Linear Responsibility Chart.....	64
Appendix E: Cable Displacement Measurements.....	65
Appendix F: Part Drawings.....	67
Appendix G: Code	80

Abstract

Stroke affects 750,000 people annually, and 80% of stroke survivors are left with weakened limbs and hands. Repetitive hand movement is often used as a rehabilitation technique in order to regain hand movement and strength. In order to facilitate this rehabilitation, a robotic glove was designed to aid in the movement and coordination of gripping exercises. This glove utilizes a cable system to open and close a patient's hand. The cables are actuated by servomotors, mounted in a backpack weighing 13.2lbs. The glove can be controlled in terms of finger position and grip force through switch interface, software program, or myoelectric signal. This project developed a working prototype of the rehabilitative robotic glove which actuates the fingers over a full range of motion across one degree-of-freedom, and is capable of generating a maximum 15N grip force.

Executive Summary

I. Background

Annually some 600,000 people are left with loss of motor function as a result of stroke.¹ This ensuing weakness, hemiparesis, afflicts the limbs one side of the body, including arms, hands, and fingers. This weakness is caused from damage to the brain, and so some motor control can be regained through rehabilitation. Recovery of motor function can be regained through repetitive motion exercises. It has been shown that robotic assistance in rehabilitation produces better results.² Current devices consist mostly of large machinery used with a therapist or unpowered orthotics. The design of this project aimed to create a robotic glove that patients can wear and use to recover hand functionality.

II. Design

A robotic glove system for rehabilitation was designed and prototyped. The device is a glove (Fig. A) with cables attached to the fingertips through cable guides. The cables run up the length of the arm and around the shoulder to a backpack, where they attach to servomotors through spools. The glove can be actuated via switch, program position, or EMG.



Figure A | Robotic glove design. Kevlar cable line is secured to the glove by custom cable guides. The cable is reeled in by servos and actuates the hand

The glove itself is made out of a spandex material, due to its flexible yet supportive form-fitting weave. The cable guides are 3D printed plastic pieces that hold the lines centered to each finger. The Kevlar cable was chosen not only for its high tensile strength but also for its flexibility to contour to a user's hand. The Kevlar thread is fed through polyethylene surgical tubing, forming a Bowden cable system to allow for the servomotors to be a considerable distance away from the

¹ (National Stroke Association 2006)

² (Abdullah, et al. 2011)

physical glove, thus relieving any unneeded weight on the user's forearm or hand. The Bowden cable system runs along the length of the arm, up around the shoulder and terminates at a backpack servo case. It is here that the inner Kevlar line is wound around a custom-made spool. The flexion and extension cables from one digit are both attached to one spool. Each spool was sized to take up the needed amount of line to move the individual finger it controls. The spools are mounted onto five servos one for each digit. The servomotors are capable of being position and torque controlled. The system is able to control each finger independently and move each digit to any position between open and closed grip, while regulating grip force through motor current.

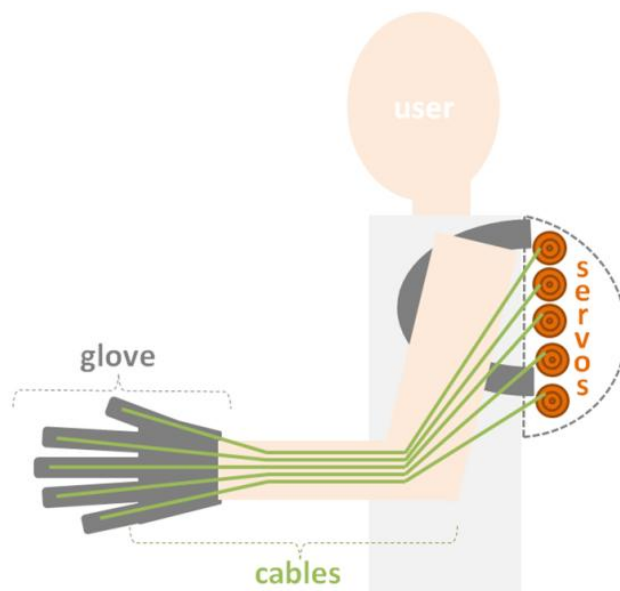

Figure B | The concept was to have a glove that could apply tensile forces in order to aid finger extension and flexion . The servomotors could be worn in a backpack with the electronics while the glove is attached to actuated cables.

The glove has three different control modes: switch, programmed position, and EMG. While in the switch control mode the glove is controlled by a three-position switch that opens, closes, and moves the fingers to an initial position– all based on the position of the switch. The programmed position mode allows a moderator to preprogram the glove to actuate between predetermined positions. This functionality would be ideal for a therapist creating an exercise regimen for their patient. Finally the EMG mode allows for the user to control the glove based on their myoelectric signals. Within this mode, the system has the ability to provide active resistance or assistance. Active resistance makes the glove provide a resistive force opposing the opening or closing of the hand, fighting against the user's intended movement whilst providing

stability. Active assistance aids the user in their intended movement, by supplying forces in the same direction.

III. Results

A. Glove & Guides

The glove and cable guides were an effective method of providing an exterior structure with which to support the hand and delineate the direction of the applied actuator tension. The cable was rigidly attached at the fingertips to provide advantageous leverage, and the centered positioning of the phalanx and palmar guides allowed for the fingers to be pulled straight.

B. Cable System

The tension in the cable system was measured to determine the pulling force being exerted on the fingers and the overall grip strength of the glove. This was done by attaching the Kevlar line to a tension gauge and actuating the servos to their extreme positions, mimicking the opening and closing displacements on the line. The resultant force was a maximum of 15N for grip strength and cable tension. The glove is capable of fully opening a human hand and closing it with grip force.

C. Servo Actuation & Spools

The servomotors used (HiTec 5465 series) were able to rotate from 0° to 200° and so the spool diameters were calculated based on this arc movement. Five servomotors were used, one for each finger. Each servomotor had a custom two-layered spool, with each layer being sized the right diameter to move each corresponding finger across the 200° arc, for both flexion and extension. The position was controlled by pulse-width-modulation and the force by current limiting. This allowed for each finger to be controlled in both position and output force independently.

D. EMG Control

The bipolar electrode-amplifiers used to control the glove were made from a design which includes a differential amplifier at the electrode. [2] This allows for less noise, as the signal at the skin interface is amplified before conditioning. Two bipolar electrode-amplifiers were used to obtain control signals; one placed on the dorsal side of the forearm to read signals from the

extensor digitorum communis, the other placed on the ventral side of the forearm atop the flexor digitorum profundis. A reference electrode was secured above the bony part of the elbow.

The differential amplifiers in the electrodes gain the signal by a factor of 20. The signals are then passed through an analog signal conditioning circuit consisting of a 2nd order high pass Butterworth filter ($F_c=10$ Hz, $G=1$), selectable gain (2x-20x), and a 2nd order low pass Butterworth filter ($F_c=750$ Hz, $G=1$). The conditioned signals are then sampled at a rate of 2000Hz, by an MSP430 (Texas Instruments) microcontroller. The EMG signal is then digitally high pass filtered (FIR filter, implemented via integer coefficients) and rectified. The moving average (i.e. mean absolute value—MAV) is recorded through a circular buffer. Changes in the moving average are used as the control cues, wherein a rise in MAV from the extensor signal actuates the hand open and vice-versa for flexion.



Figure B | Final prototype system assembly. The glove and cable guides connect the Kevlar cable through a Bowden system, to a backpack housing spools on servomotors. The servomotors spin the spools to reel in slack from each finger; the cables slide through the Bowden system and pull on each finger to desired position through the Bowden system.

IV. Discussion

Overall the prototype met the objectives of the design. It provided a portable and effective means of repetitively opening and closing the user's hand, while allowing some adjustability in terms of tension, hand size, control, and implementation.

Pre-tensioning of the cable line after donning the glove proved to be a significant factor in the functioning of the system. A taught line allowed more effective movement, wherein the servomotors could pull the cables and actuate the fingers with more tension. In the prototype, the tension was adjusted by tying the cable line attached to the glove and the line from the servomotors; having such an attachment point proved simple for changing tension while testing and for adjusting between users. The hand-tensioning method worked but was time-consuming and imprecise. Therefore a method for dynamic tensioning would be recommended. Such a method could involve using servomotors or motors capable of rotating 360° and therefore having the capacity to automatically reel in a continuous line until taught. Let it be noted however that using a motor would make position control less precise than servomotors and that the capability of the actuators to spin infinitely would pose the danger of hyperextension or hyperflexion of the user's fingers.

The prototype rehabilitative robotic glove proved that the design is effective and with future developments, its potential implementation can be applied to other uses for assistance and rehabilitation.

Acknowledgements

The group would like to extend our gratitude:

For inspiration,

Our friends and family,

For assistance in machining parts,

Neil Whitehouse, Erika Stults

For helping with pieces and components,

Pat Morrison, Tom Angelotti, Lisa Wall, Pu Liu

And for all the guidance, support, and knowledge,
Professor Ted Clancy and Professor Gregory Fischer.

Thank You.

1. Introduction

Each year more than 750,000 people are affected by a brain damaging stroke. From these attacks, 80% are left with some degree of lost motor function and strength on one side of the body. This ensuing weakness is called hemiparesis, and limits the dexterity of people's hands and arms.³ These patients are left to seek out conventional rehabilitation therapy or an alternative form of physical assistance. Current resources are costly and are primarily provided by healthcare professionals inside a hospital or medical facility. Along with occupational therapy, the devices that are used to treat patients are mostly large tabletop machines or, are unpowered— only providing the offer of physical resistance for the patient to work with. The design of this project aimed to create a robotic glove that patients can wear and use to recover hand functionality.

A robotic glove system was designed, capable of actuating finger movement with a cable array. Kevlar cables were secured to a fabric glove via custom plastic guides. The cable runs up the guides, through plastic surgical tubing, as Bowden cables. The cables are attached to the fingertips on the glove on one end and to servomotors in a backpack on the other end (Figure 1). The servomotors hold spools which reel the cable line in to bend the fingers in either flexion or extension. The position and force at which the spools spin can be controlled with a control board. The control board is operated by an MSP430 processor and is capable of current limiting the servomotors. Various control methods for the glove were implemented, including switch, software program, and EMG control.

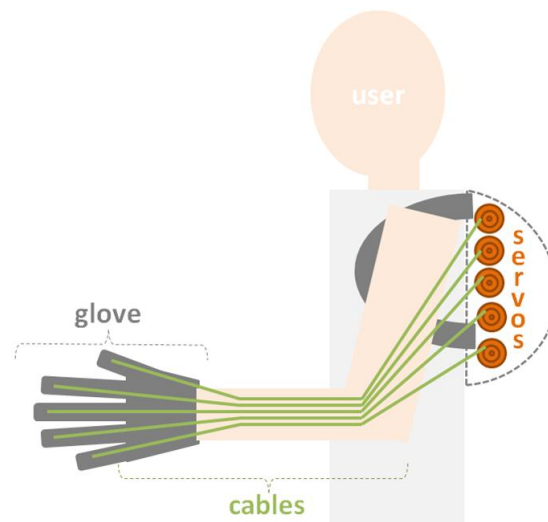

Figure 1|The concept was to have a glove that could apply tensile forces in order to aid hand movement. The servomotors could be worn in a backpack with the electronics while the glove is attached to actuated cables.

The glove could be implemented for user's recovering more independently. The switch mode allows for direct position and force control of the fingers and grip. The programmable control mode allows for a therapist to create an exercise regimen that the user can activate at a different

³ (National Stroke Association 2006)

time. The myoelectric control allows for the user to activate the glove independently and moreover offers the options of providing assistance or resistance. The assistance would amplify force in the direction the user attempts to move (open or close hand). The glove can also provide resistance in the opposite direction in order to aid the user in stabilizing their movements, or for muscle tone exercise.

The focus of this design was to create a prototype glove device that would open and close a user's hand. The design could be implemented for a variety of users and needs, such as recovering stroke survivors.

2. Background

2.1. Hand Weakness

Physical disability after a stroke is characterized by loss of dexterity and strength, to the afflicted side of the body.⁴ This loss of strength is due to lost motor function and coordination of muscle recruitment. That is to say the brain is injured but the muscles and nerves are still functional. Repetitive motion exercise helps to re-map the motor function in the brain; much like a child learning to walk for the first time, so too can a person re-learn how to move their body again.

2.2. Rehabilitation Methods

Rehabilitation of strength in the paretic hand is improved via repetitive controlled motion of the hand.⁵ Occupational therapy for stroke rehabilitation involves the repetition of tasks that aid in accomplishing tasks of daily living. In occupational therapy this involves various tasks and games that build up strength and dexterity. These activities include exercises such as picking up objects and placing them elsewhere, dressing, eating; and other similar tasks that require opening and closing the hand, and manipulating objects in coordination. Moreover the level of difficulty of each task depends on the patient's level of functionality and the occupational therapist's assessment.⁶ Occupational therapy is tailored to the user's needs and ability and as their functionality improves, the level of therapy increases.

Occupational therapy occurs largely in hospital or clinical settings, but can migrate toward home therapy. Home therapy incorporates the recovery of daily-living-activity functions as well as incorporating environmental adjustment at home and can help improve efficacy. The ability to perform rehabilitation at home is beneficial for functional and psychological performance, and for independence.⁷

In general, factors that improve recovery after a stroke include early intervention, repetition, and motivation.⁸ Patients who are more active and persistent in their rehabilitation, are better able to regain more function.⁹

⁴ (Canning, et al. 2004)

⁵ (Butefisch, et al. 1994)

⁶ (Richards, et al. 2005)

⁷ (Ng, et al. 2005)

⁸ (Oujamaa, et al. 2009)

⁹ (Oujamaa, et al. 2009)

2.2.1. Assistive and Resistive Exercise

During rehabilitation the patient may use exercise equipment or other devices that provide assistance and resistance in therapy. Exercising the recovering area is beneficial in recovery, as building strength increases function.¹⁰ Assistive intervention allows for the patient to regain function in early stages of recovery. Resistive exercises allow for the patient at a higher functional level to strengthen their body. In some cases a combination of assistance and resistance can be used in a rehabilitation sessions in order to develop various functions.

2.3. Robotic Rehabilitative and Assistive Devices

Modern developments in biomedical technologies have led to the use of robotic systems in physical assistance and rehabilitation. Companies like iWalk, have been working on a number of different prosthetics. The PowerFoot One (Figure 2, right) is an advanced complete ankle-and-foot prosthesis. The device takes measurements thousands of times a second to accurately reproduce the movement of a fully functional human foot. Not only does this device mimic human foot movement, but it is one of the first devices that uses its own movement to power itself; this allows for the device to become more compact and portable. The Rheo Knee (Figure 2, left) developed in Iceland is another example of advanced robotic prosthetics. This design is innovative because it tracks the users' gait and adapts its walking algorithm to better suit the user (Bogue 2009). DEKA a company, better known for the creation of the Segway, also developed the “Luke Arm” (Figure 2, middle). This commonly publicized device is a prosthetic aimed toward individuals that are missing an upper limb. This device is designed to provide a person with a partially articulated robotic arm that uses foot pads to control and move it.¹¹



Figure 2 | Several robotic prosthetic devices: (Left) Rheo Knee by Ossur. (Middle) Luke Arm by DEKA. (Right) BiOM Power Ankle by iWalk.

http://www.mutualortho.com/assets/images/rheo_knee.jpg, <http://www.iwalk.com/>,
http://www.popsci.com/files/imagecache/article_image_large/articles/dekas-luke-arm.jpg

¹⁰ (Oujamaa, et al. 2009)

¹¹ (Adee 2008)

Current devices available for hand rehabilitation are composed of either glove-like orthotics or larger robotic machines. The glove-like devices tend to be unpowered orthotics that are portable, providing only support and coordination. Unlike passive orthotic devices, exoprosthetic devices are able to achieve some sort of actuated movement. The robotic machines tend to have sensors and motors for feedback and assistance, but are limited to desktop use. The Tokyo University of Agriculture and Technology is developing an exo-suit to help the elderly and people with disabilities¹². A Japanese IEEE group developed a robot (Figure 3) which holds a human hand and manipulates it in various degrees of freedom. This system is a desktop unit with an array of motors and joints for each digit. The actuators provide active manipulation of all digits for both flexion and extension, as well as wrist rotation. The robot is controlled by a master-slave system in which a control glove is worn on the healthy hand and its motions are reflected onto the arm undergoing rehabilitation.¹³ Compact devices that fit on existing limbs, like Myomo's mPower100 elbow system, aim toward home use. These technologies highlight the possibilities of control, portability, and feedback in prosthetic and orthotic devices.



Figure 3 | Hand assist robot by Japanese IEEE group. Actuates each finger individually for flexion and extension. IMAGE: Ueki et al.

Robotic devices allow for more efficient and precise assisted therapy. A 2011 study comparing robotic and standard hand therapies for recovering stroke patients, found that those using the robotic system recovered more effectively and with less injury.¹⁴ Another example is by an MIT student that worked on “A Robot for Hand Rehabilitation” (Figure 4). The work includes many designs and considerations as well as significant background research for a lot of the fine motor functions and degrees of freedom of the hand¹⁵, thus

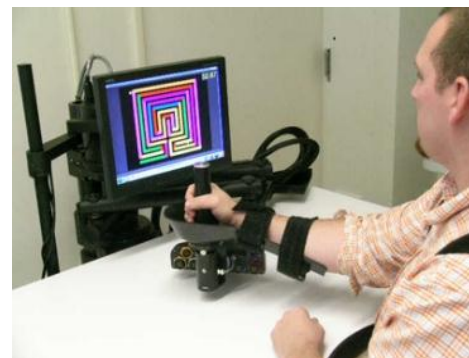

Figure 4 | MANUS stroke therapy system by MIT. Provides visual game therapy for elbow and arm movement.

IMAGE:
<http://web.mit.edu/newsoffice/2010/stroke-therapy-0419.html>

¹² (Bogue 2009)

¹³ (Ueki, et al. 2010)

¹⁴ (Abdullah, et al. 2011)

¹⁵ (Jugenheimer 2001)

lending way to more articulated designs and functions. These systems allow for guided motion in therapy, which can decrease injury and increase recovery efficiency.

2.4. Existing Glove Devices

These robotic technologies can take on more compact forms such as gloves. A glove design allows for a wearable device that is intuitive to use. A patent for a “Hand Rehabilitation Glove” states a design wherein the patient wears a glove that is comprised of pockets of a compressible fluid to exercise individual fingers. The glove is intended to aid in therapy and to minimize the stresses on the hand, fingers, and joints during therapy.¹⁶ The complexity of these robotic systems, as



Figure 5 | SaeboFlex by Saebo, Spring-loaded orthotic device which holds the hand open.

well as the level of feedback and interaction can vary by design. One of the many current forms of rehabilitation for the hand includes a device called the “Hand Tutor.” The device is a glove that tracks the users hand motions and allows them to play games during hand exercises. This gives feedback to the patient and allows them to improve the motor function of their hand.¹⁷ A wearable design such as this is suited for use in everyday life, so that rehabilitation becomes concurrent with daily tasks. The SaeboFlex by Saebo is an unpowered wrist-hand-finger orthotic being marketed and used in therapy for patients that need to regain muscle tone in the hand. This device consists of adjustable springs used to provide resistance and stability to the fingers during rehab exercises. A group of engineering undergraduates from Columbia created the “J-glove” which uses cables to provide tension during extension.¹⁸ The cables ran through tension sensors and were driven by motors. The motion of extension via cable tension could also potentially be utilized for flexion.

¹⁶ (Brassil and Brassil 2002)

¹⁷ (Carmeli, et al. 2010)

¹⁸ (Ochoa, et al. 2009)

2.5. Biomechanics of the Hand

The human hand contains a system of muscles and tendons which form a hierarchy of bundle fibers. The extensor digitorum muscle is located on the dorsal side of the forearm and attaches to the fingers through tendons. These tendons are all connected to the main muscle; however some fingers are crosslinked more closely to each other, as seen in Figure 6. The degree of this cross linking in tendons varies per individual, but the middle, index, and ring fingers are more prominently crosslinked.¹⁹ In terms of movement, this results in coupled actuation, where the middle and ring fingers move together to some degree, so that they cannot be moved entirely independently.

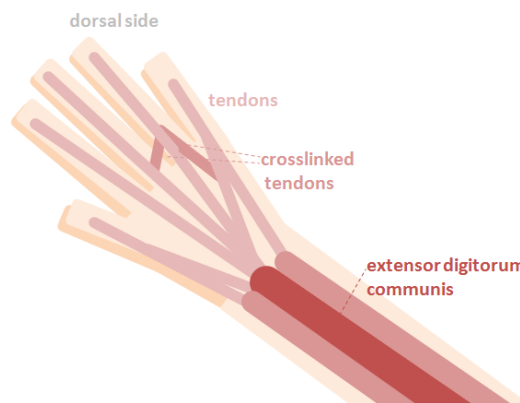

Figure 6 | Tendons of the fingers are linked to each other as they attach to larger muscles.

The hand contains 14 finger bones, the phalanges, categorized into three sections: distal, intermediate, and proximal, as seen in Figure 7 below. The thumb has only proximal and distal phalanges.

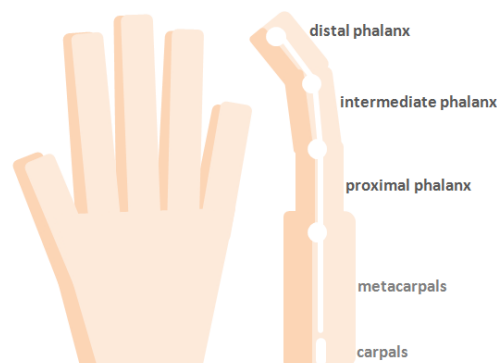

Figure 7 | Bones of the human hand. The phalanges are the bones which make up the digits

¹⁹ (Lang and Schieber 2004)

Robotic hand rehabilitation and assistive devices are designed to function at a similar level of complexity as the human hand. The biomechanics of the human hand have long been studied. The tendons in the hand are a system analogous to wires under tension. The maximum forces that the hand can generate during grip range from an average of 200-400N, depending on gender and age.²⁰ During daily tasks the forces and stresses in the individual finger joints can vary from task to task and on the force applied. Tasks such as opening a jar can generate up to 100N stresses in the joints.²¹ These numbers are critical in calibrating an exoprosthesis that will function like a normal hand and in setting a limit for rehabilitation purposes.

2.6. Electromyogram Acquisition

Muscle movement in the body is controlled by signals sent down by the brain through the nerves. These signals generate electrical activity in the muscle (myoelectricity), which can be sensed by electrodes in what is called electromyography (EMG).²² The surface EMG signal exists at a voltage range of 0-10 mV at a useable energy frequency of 0-500Hz.²³ These EMG signals (Figure 10) can be acquired by a signal processor and sent to a control unit to operate electronic devices. Typically, the spikes in the power of the signal are used as the control cues. EMG controlled prosthetics have been in use for some time. Due to the naturally random nature of EMG waveforms, a simple control design is preferable for current devices.²⁴

During a gripping motion, the fingers are predominantly moved by large muscles in the forearm. When the fist is opened, the extensor digitorum pulls back (extends) the fingers. And during the flexion of the fingers to close the hand, the flexor digitorum profundus provides much of the necessary tension. These muscles are large and relatively close to the skin. Surface electrodes are then capable of detecting the EMG from skin contact atop these muscle groups.

²⁰ (Mathiowetz, et al. 1985)

²¹ (Butz, Merrell and Nauman 2011)

²² (Day 2011)

²³ (Groh n.d.)

²⁴ (Cipriani, et al. 2008)

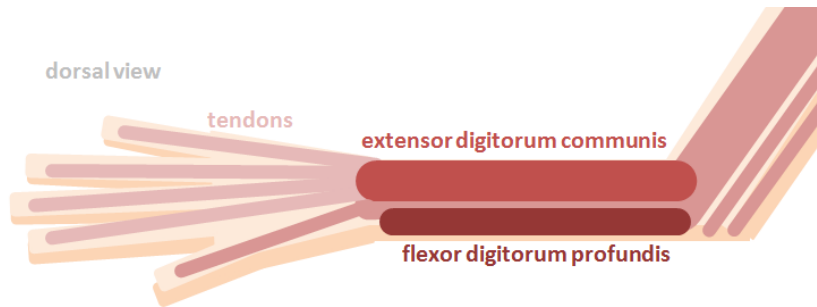

Figure 8 | The major muscles that open and close the hand are located on the forearm. The extensor digitorum communis opens the fingers and the flexor digitorum profundus closes the fingers.

An affordable surface electrode-amplifier for obtaining an electromyogram and an accompanying signal processing circuit were designed at Worcester Polytechnic Institute. The design includes two circular stainless steel heads connected to an instrumentation amplifier circuit all packaged within an epoxy shell. The amplification circuit consists of an instrumentation amplifier and differentially amplifies the signal by a gain of 20.²⁵ Thereafter the design includes a circuit with a high-pass filter, additional variable gain, and a low-pass filter.²⁶ This electrode-conditioning design provides an amplified and filtered EMG (Figure 10) which can be utilized for device control, based on power characteristics.



Figure 9 | Custom EMG surface electrode developed at WPI.

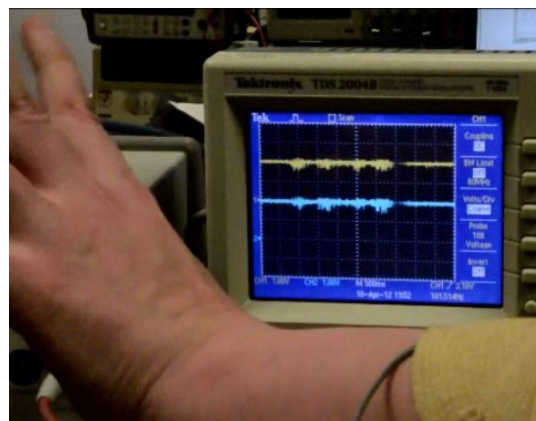

Figure 10 | EMG from forearm muscle viewed on oscilloscope. Notice the spikes in the waveforms correlating to muscle contraction

²⁵ (Salini, Tranquilli and Prakash 2003)

²⁶ (Clancy 2011)

3. Project Strategy

3.1. Client Statement

This project aimed to create a rehabilitation system for persons with low hand functionality at different stages of recovery from stroke. The device focused on the flexion and extension of the fingers. The client statement, as developed by the design team, was as follows:

Design a robotic glove that will assist users with varying levels of hand dexterity and strength; utilizing an intuitive, portable, and affordable system interface

3.2. Objectives and Constraints

The objectives and constraints for this project were generated from the client statement and the scope of the Worcester Polytechnic Institute major qualifying project. The design group decided to aim for a robotic device that could be worn on the forearm and hand. This device would attach to the user’s fingers and use motors to actuate the fingers. Furthermore the design would allow for various levels of therapy and basic mechanical assistance, in terms of gripping by flexion and extension of the digits. From these criterion an objectives tree was drafted to outline the goals of the design, as seen below in Figure 11.

Universal	Safe	Comfortable	Reliable	Intuitive	Affordable
Various Therapy levels	Feedback Sensors	Ergonomic Motions	Durable materials	Open/Close Grip	Simple Components
Multiple controls	Earthground Isolated	Lightweight	Motor-driven Force	Multiple Controls	
Adjustable Design	Mechanical Fail-safes			Manual Switch	
Adjustable cables	Motor Disengage			EMG Control	
Standard glove sizes					

Figure 11 | Objectives tree for robot glove design.

3.2.1. Primary Objectives

The primary objectives for the design were to create a device that would be: universal, safe, comfortable, reliable, intuitive, and affordable. Universal referred to the ability of multiple users to benefit from utilizing the device. This foreshadowed adjustable fittings for different sized hands, multiple control options for various therapy levels, and a standard form fit for the hand. Safety, as an objective was an aim to allow for smart fail-safes and precautions. Comfort was an objective, with the regular user in mind; a comfortable device is more desirable for frequent use. The intuitive aspect was key in designing a device that would be worth marketing and using; moreover an intuitive control system would greatly facilitate rehabilitation. An affordable device would be able to reach more people that are in need of rehabilitation or assistance.

Table 1 | Objectives compared in pairwise chart, by design team. Safety and reliability were rated as the highest objectives.

	Universal	Safe	Comfortable	Reliable	Intuitive	Affordable	Score
Universal		0	1	0	0.5	1	2.5
Safe	1		1	1	1	1	5
Comfortable	0	0		0	0	0	0
Reliable	1	0	1		1	1	4
Intuitive	0.5	0	1	0		1	2.5
Affordable	0	0	1	0	0		1

3.2.2. Project Constraints

The constraints for this design project arose from the limits of time and the nature of the end goal. First, the entire device had to be able to fit on an arm and be independently powered. This also implies that the whole apparatus must be relatively lightweight. This constraint is from the desire to create a device that can function as an intuitive rehabilitation system as well as an assistive exoskeleton. Second, the entire project had a deadline for completion: the design, prototyping, machining, paper work, etc had to all be completed within an academic year; in order for the team to qualify for graduation. Third, the team had a start budget of \$640 (~\$160/person) from each respective department; so this set the budget for the project and prototype(s). Finally, the device must be safe for the user as to not cause physical harm.

3.3. Project Approach

The end goal was to design and construct a working prototype of a robotic glove. The end user would have the ability to choose from multiple control modes: switch, EMG, and programmed. The switch control mode would have the ability to open and close a hand. The EMG control mode would use electrodes to harness the users' bioelectric signals. The programmed control mode would allow for various preprogrammed motions as well as expansion upon the project. The tasks to accomplish this were outlined in a work breakdown structure (see Appendix B) and plotted in a Gantt chart (Appendix C). The project could be then divided into five phases: research, design, prototyping/testing, design finalization, and documentation.

3.3.1. Research

The research involved looking into the needs of users with hemiparesis and to review literature of similar therapy devices. The research topics were divided into the team member's areas of expertise: robotics (motors, controls, sensors), machining (materials, models, specs), programming (circuit boards, processors, signal processing), and biomedical engineering (biomechanics, forces, EMG). This division of topics also gave way to the breakdown of tasks and duties as shown in the linear responsibility chart (Appendix D).

3.3.2. Design Phase

The design process was ongoing throughout the entire project. It began by defining the client statement and objectives. Design alternatives were created and the team researched what had been done before and where there was more innovating to be done. The design was also broken down into subsystems by areas of expertise. The subsystems of the device are as follows: glove, cables, actuators, control board and programming, and EMG electrodes with signal processor.

3.3.3. Prototyping and Testing

The separate subsystems were designed and prototyped, each undergoing certain tests. The mechanical components and motor were tested for forces produced and stresses caused. The microcontroller was tested for functionality and I/O read out. The EMG signal processing was tested on different muscles and with different hand movements in order to obtain characteristic signals.

The entire prototype system was then assembled for concurrent testing. The device was mounted on a wooden mannequin hand for initial safety testing. The motors were actuated to

their upper limits to see if there was any damage or strain to the wooden hand. Then the various controls were tested for accuracy and reliability. The total exerting grip force of the device was measured using a tension gauge. The results of the testing were recorded and considered during the finalization of the design.

3.3.4. Design Finalization

The final design was developed using the results of the prototype testing. A final design review considered all the objectives as well as the remaining constraints. This design was then assembled and prepared for the final presentation

4. Design Alternatives

The goal of this project was to design an actuated glove that could extend and flex the fingers while providing support. This project focused in design choices incorporating soft robotics, which would allow for a design that more closely mimicked the behavior of natural muscles and tendons. The structure of a soft glove with actuators was chosen as part of the design in order to create an intuitive user interface. Several variations of an actuated glove were considered.

4.1. Alternative Actuation

In designing the glove, several actuation methods were investigated, including but not limited to springs, rotary motors, pneumatics, and remote controlled (RC) servomotors. Some of these actuators could potentially be located locally on the hand or forearm, and others would have to be remotely mounted. Each of the various methods had their pros and cons and would drive the glove in a specific way.

4.1.1. Springs and Elastics

Actuating the glove with springs would provide a passive method to either open or close the glove, but not both. This method would be combined with an actuation method for the opposite action (close or open) to provide active assistance to drive the fingers. The springs could hold the hand open or closed until actively actuated by positioning each spring about each finger joint. The advantage of spring actuation is that it can lead to more compact design and can also provide a constant holding force on a users' hand. The disadvantage is that there is a loss of control in one direction of actuation. Instead of being able to vary the required amount of force, the limit is the amount of force produced by the springs.

Elastics could be implemented similarly, where they would provide passive tension. Elastics would allow for a lower profile than springs, but face the same cons of not being directly controlled. Moreover elastics have greater wear and creep than springs.

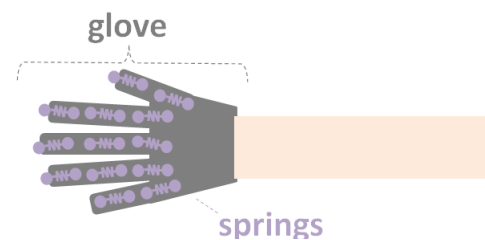

Figure 12 | Spring actuated glove, wherein each spring is about each finger joint for one movement direction (open or close).

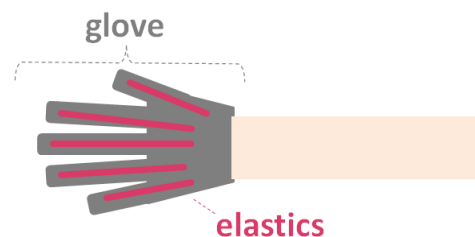

Figure 13 | Elastic actuated glove wherein elastic tension would hold the hand in position by pulling on each finger, in either flexion or extension.

4.1.2. Cable Drive

A cable driven system would be similar in function to tendons being pulled by muscles. The cables would be attached to each finger through the glove in a similar pattern to tendon attachments. Cables would require coupling with an actuator in order to provide tension and movement.

4.1.3. Motors

Motors coupled with cables would provide a tensile force to actuate the fingers. A rotary motor could reel in cable attached to the glove, in order to pull on each digit, or the hand as a whole. This actuation method would provide the potential for tensile and force control over the hand. Stepper motors could also be considered because they allow for position control and 360° rotary motion. The disadvantage

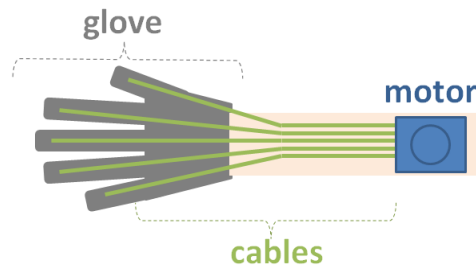

Figure 14 | A cable driven glove with rotary motor actuation. Cables attach to fingers via glove. Cable tension adjusted by motor reeling in cable.

is the price of the motors. The torque desired from the motors generally leads to a price in the hundreds of dollars. This cost per motor would result in an expensive device that would not be beneficial to the end user.

4.1.4. Pneumatics and Hydraulics

The method of actuating the glove with pneumatics or hydraulics would provide control over the force applied to the hand. This method can allow for a great degree of control over the force, by controlling the air pressure and flow into the system. Pneumatics/hydraulics also provides a great size to

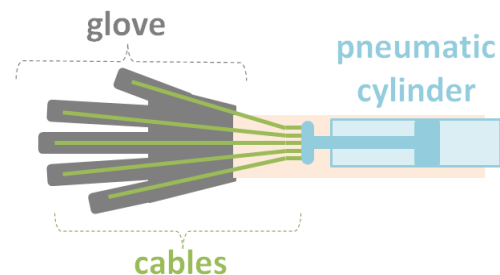

Figure 15 | Cable driven glove with pneumatic cylinder for actuation. The motion of the piston due to air pressure determines cable tension.

force ratio. The disadvantage of this method is that a piston only has two positions, open and closed. Pneumatics/hydraulics also require the use of an air compressor or accumulator tank, with limit capacity, which would limit the mobility, increase the overall size of the system, and be noisy during operation.

4.1.5. RC Servomotors

Actuating the glove with RC servomotors would allow for both force and position control of the hand. The RC servomotors have a better price-to-torque ratio. The disadvantage to these is that they are limited to only a partial revolution.

4.2. Cable-Spring Glove

One design was to combine previously used methods of actuation. The Saebo-flex proved that springs could be used as a passive means of opening the hand and providing tensile support. The J-glove utilized motor-driven cables to pull the fingers closed. This MQP team tested a glove that would flex the hand with cable tension and then release and allow springs to extend the hand once again.



Figure 16 | Spring-cable actuated glove prototype. The cable allows for active flexion and the spring provides limited extension upon release of cable

This sort of system provides active flexion and passive extension as seen in Figure 16 and Figure 17. This means that only the flexion can be controlled in terms of position and force while the extension merely relies on the spring force to restore the hand to an open position.

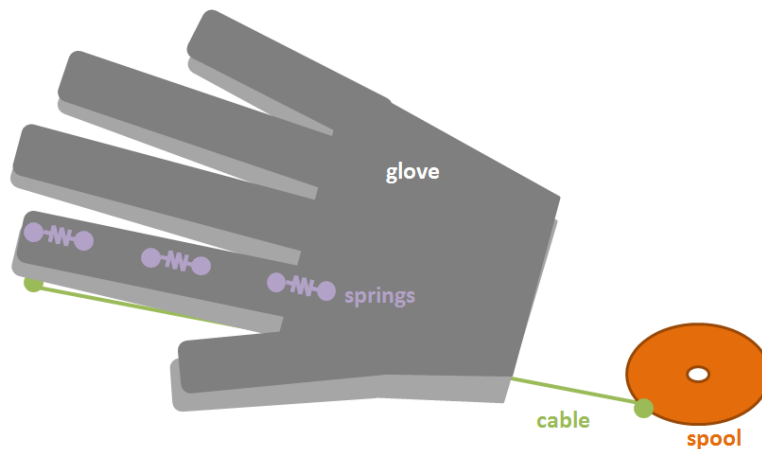

Figure 17 | Glove design incorporating springs for extension and cable tension for flexion. Note that only the flexion is actively controlled, as the springs dictate the extension of the fingers.

4.3. Cable-Spool Glove

The final design consisted of driven cables for both extension and flexion. The glove has custom cable guides to support the cable and create a linear path for actuation (along the long axis of each finger). The cables are attached at the dorsal side of each fingertip, the line runs around a spool on a servomotor. A second cable is attached from the spool to the palmar side of the fingertip. Each finger is part of an effectively closed loop of cable, which is displaced to actuate the fingers. This method allows for active flexion and extension, wherein the levels of displacement and force of each finger have the capacity to be controlled.

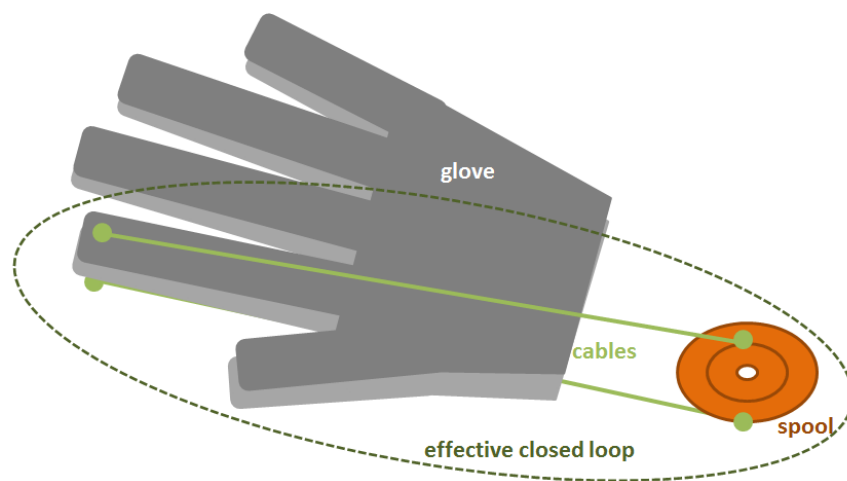

Figure 18 | Glove design incorporating cable tension for both flexion and extension. Cables are attached to the fingers and actuated through spools to flex and extend the fingers.

5. Final Design

The final design consists of a glove which actuates the fingers in flexion and extension, via cable tension. The cables attach to spools on servomotors in a backpack; this connection is made possible through the use of a Bowden cable system which allows the cables to slide within tubes and the force of the servomotors to be translated to the fingers. The system is controlled by a microcontroller, also in the backpack. The microcontroller offers three control options: switch mode, programmed mode, and EMG mode. The EMG mode uses electrodes on the forearm to provide control signals from the flexor and extensor muscles of the fingers.

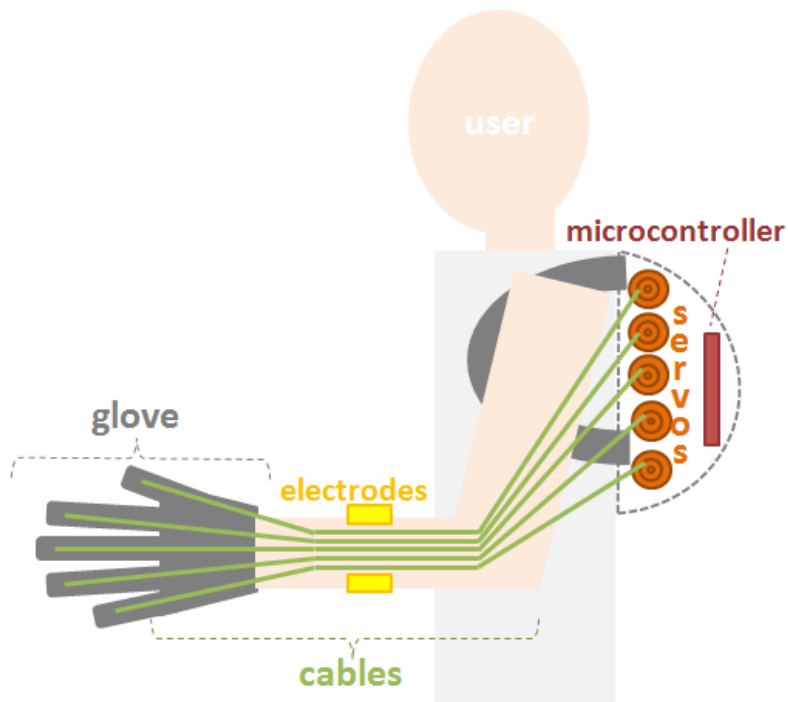

Figure 19 | System diagram: the glove is connected, via cables, to servomotors in a backpack. A microcontroller in the backpack controls the servomotors and receives control inputs from the electrodes, a switch, or a software program.

5.1. Mechanical Subsystem

Mechanically, the final design encompassed a subsystem which includes: a glove, cables, and actuators (see Figure 20). This mechanical subsystem allows for an effective, compact, and modular approach to a robotic stroke rehabilitation glove. In using this device with someone with limited hand movement from an injury or stroke, the design tried to keep as much weight and components off the hand and forearm. Servomotors are housed in a backpack that the user wears. The servomotors spin custom made spools with radii that are sized based on the amount of cable needed to be pulled to extend and flex each finger individually. As the spools rotate they take up slack in one direction while providing tension on the other side. The cables that the spools wind up, extend down to the forearm through a Bowden cable system. The cables are then fed up through a rigid guide mounted on the forearm. The forearm mount is the connection between the cables from the glove and the cables from the servomotors. By having two separate cables the tension can be adjusted for different users at this junction. The cables on the hand run parallel to the long axis of the forearm. The cables are held in place by custom guide pieces attached to the glove. This system not only allows for modularity, but is also a simplistic and effective method of actuation of the hand.

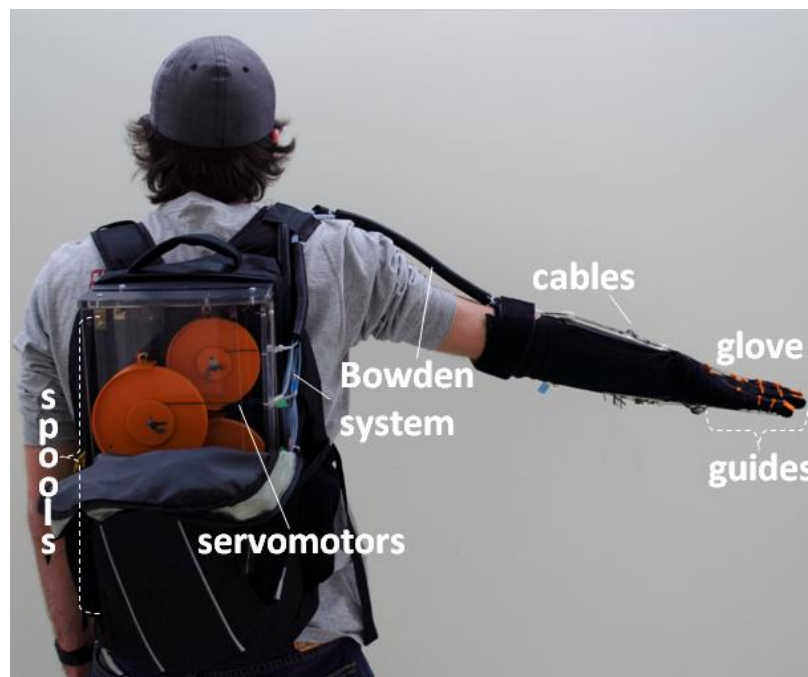

Figure 20 | Mechanical sub-system consists of glove, cable guides, cables, Bowden system, spools, and servomotors.

5.1.1. Proof of Concept

The first glove design was a proof of concept to test how running a cable along the palm of the hand would work and how effective this would be to flex the digit. Preliminary cable guides were placed on the glove along each phalanx of the finger to guide the cable along the center of the finger. As seen in Figure 21, this design consisted of a soft textured gardening glove with slotted, plastic rings, as cable guides. This model glove served its purpose in holding the cable guides and pulling the tip of the finger as the cable was tensed. The cable was run through plastic rings glued onto the glove. The cable was pulled and the finger was actuated. This particular glove had a high friction material on its palm which interfered with finger movement. When moving the fingers past each other they would sometimes catch on one another and impede motion. This was a noted factor in choosing the material of the glove for the final prototype.



Figure 21 | Proof of concept set-up: wire secured via PVC rings on a garden glove. This demonstrated that cable tension was capable of actuating the finger. Note this glove was merely used for testing.

5.1.2. Glove Design

The main design requirements for the final glove were to keep it low profile, comfortable, and easy for someone with limited hand mobility to use. The material of the glove itself needed to be form fitting to the hand in order for the actuation to be effective. Keeping the cable lines tethered to both the palm and the dorsal side of the hand using the cable guides allows for a low profile design. The use of a cable system also permits for there to be no local actuator devices near the hand, keeping weight off the arm. The type of glove selected was originally designed to be a glove liner and is already made of slim and comfortable material. The material of the glove is a spandex, moisture-wicked material (Seirus Innovations, Thermax Deluxe Glove Liner).

5.1.3. Cable Guides

The cable guides used in the first model were prototyped from PVC pipes and safety pins. Using the overall shape of these, low-profile and effective cable guides were created (detailed in Appendix F). The final cable guide system were rapid-prototyped parts, spread into three different types (Figure 22): fingertip, phalanx and palmar. The fingertip piece is placed onto the tip of the glove at each finger to create a fixed point for the cable to be attached to the glove. This is the only point on the glove that the cable is rigidly attached to. Attaching the cable at the fingertip maximizes the leverage on the finger. The phalanx guides

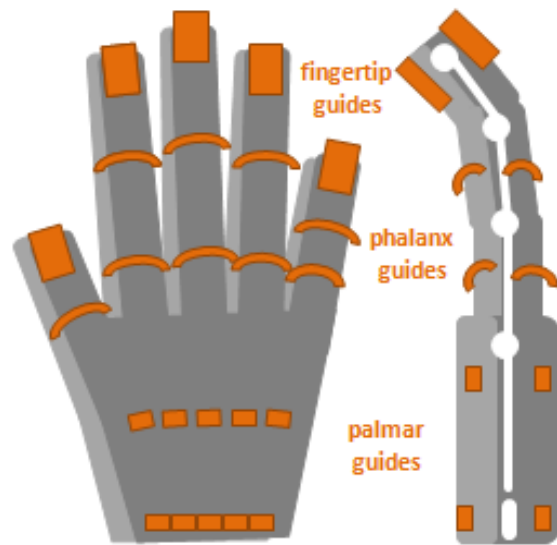

Figure 22 | Cable guide diagram. Three types of guides: fingertip, phalanx, and palmar. Guides were placed in on either side of each joint in the finger in order to allow comfortable bending.

are half-circle pieces that are placed on the intermediate and proximal phalanges, between the knuckles (only intermediate for the thumb). The guides are glued at the midpoint of each phalanx of the finger in order to distribute the forces along the finger and to align the cable tension along the axis of flexion/extension. The guides have to be centered along this axis in order to prevent adduction or abduction of the fingers. These pieces are meant to tether the cables as close to the finger as possible in order to allow the maximum range of motion and force to be translated along the finger. The palmar cable guides are smaller pieces mounted on the

dorsal side of the hand and the palm to help keep the cables taught past the wrist, as seen below in Figure 23.



Figure 23 | Final cable guide assembly on glove. Cable lines run centered down the middle of the long axis of each digit and are attached rigidly at the fingertips. Note fingertip, phalanx, and palmar guides.

5.1.4. Cable Selection

A series of cables were tested on the proof-of-concept glove. The two types of cables used were suture, and steel hanging wire. These are seen in Figure 24; the cable on the index and middle finger were a lot more rigid and had a more than enough tensile strength than was needed to flex the finger. The wire on the middle finger was mounted using the cable guides, which brought the cable closer to the hand. This caused the cable not to be able to bend and flex in between the pivot points, due to the rigidity of the cable. Evaluating the test trials of the cable, it was determined that a strong but flexible cable was needed. The suture was discovered to be strong enough to pull the finger, but also flexible enough to bend with the hand. However, it was determined that the non-dissolvable suture is commonly made of nylon and polypropylene, which both have a high elongation of about 30-100% and 100-600%, respectively depending on

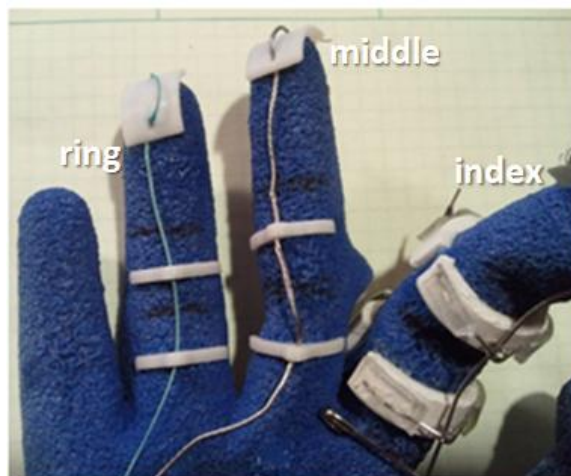

Figure 24 | Cable selection on proof-of-concept glove. Suture (ring finger) and wire (middle and index) were attempted on custom cable guides. The custom cable guides (ring and middle) were compared to the proof-of-concept PVC rings (index finger).

the specific type of material²⁷. This means over time the suture could stretch from anywhere between 0.3 to 6 times its initial size. With the potential for variability in its length, suture would not be ideal for a system that needs to maintain a near-constant dimension. The final choice was Kevlar-K 49 thread; similar to the suture it has a low and flexible profile but has tensile strength comparable to that of the steel cable. The Kevlar line stretches no more than 0.018 to 0.03 times its initial length (elongation of 1.8-3%)²⁸ making it ideal for this application. The Kevlar braided cord that was used has a 1mm diameter and a tensile strength of 890N. Figure 25 shows the material properties of tensile strength versus the elongation of the three cable types.

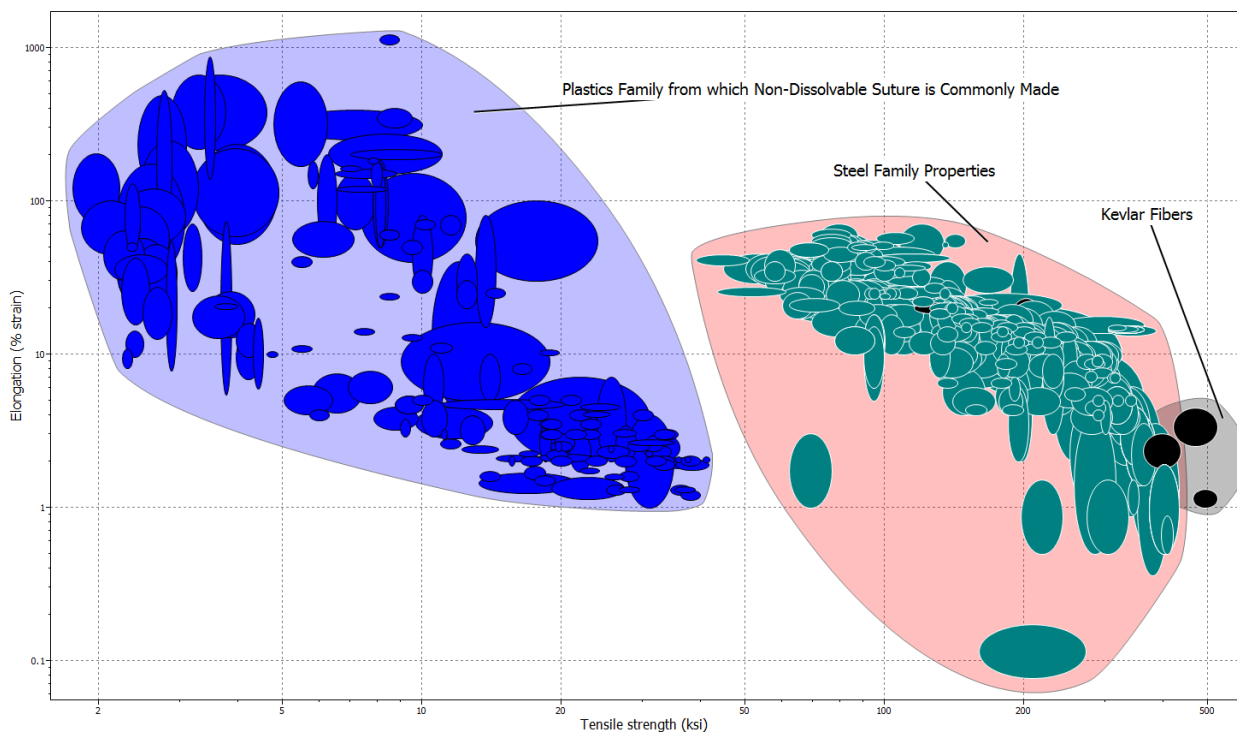

Figure 25 | Graph of material options for the cable, notice Kevlar possesses the highest tensile strength, yet moderate elongation.

²⁷ (Granata Design Limited 2011)

²⁸ *ibid*

5.1.5. Bowden Cables

In order to minimize the number of parts on the arm, and to allow more options in terms of actuation, the team studied alternative methods to transfer cable movement over a distance. Looking back at some preexisting prosthetic devices it was

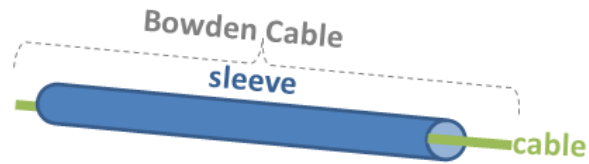

Figure 26 | Bowden cable, outer sleeve tubing with cable inside.

found that Bowden cable systems are often used. This system works the same way that a bicycle brake cable works, where force is remotely transferred from handlebar to wheel. As seen in Figure 26 and Figure 27, shielding the cables allows for the tension to be applied from a distance away from the end effector. The cable is able to slide inside the sleeve and transfer the displacement and tension; shielding the cables from the backpack to the forearm. Polyethylene 0.11 inch diameter surgical tubing was used as the plastic sleeve.

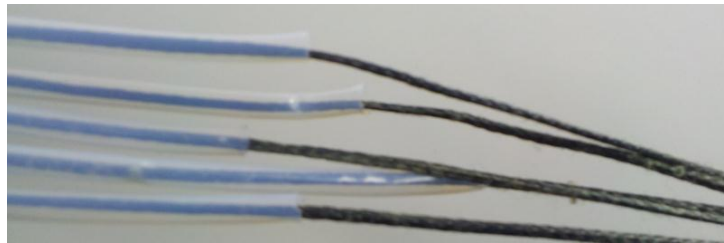

Figure 27 | Kevlar cables running from the hand through plastic surgical tubing, acting as a Bowden cable system.

5.1.6. Cable Displacement

Spools were designed in order to displace the Kevlar line for actuation. Through testing it was discovered that there is a larger displacement in flexing the fingers than in extending them. In terms of cable displacement, in flexion the cable must travel the length of the digit plus the curling of the fingers. While in extension the cable is only displaced over the radii of the knuckles (see Figure 28 and Table 2). So in order to actuate the full range of motion, the servomotors have to reel in more cable when flexing than when extending, while still rotating about the same arc.

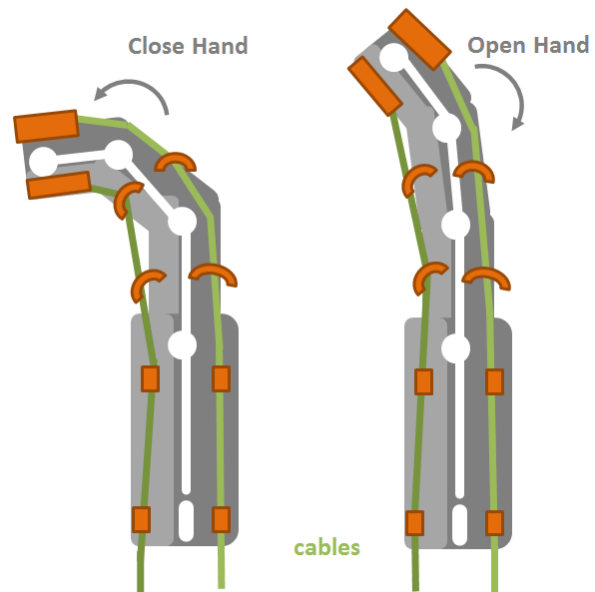

Figure 28 | Flexor cables are tensioned to close the hand, and extensor cables to open the hand.

The magnitude of cable displacement needed to fully flex and extend the fingers was measured based on hand sizes of the design team. After the glove was donned, the hand was then flexed and the movement of the flexor Kevlar line was measured. The same was done for extension. The measurements, seen in Table 2, were used to size the spools to displace enough cable to move the fingers.

5.1.7. Spools

The Kevlar lines for both the flexor and extensor are attached to the same spool. This can be done because the flexion and extension motion is coupled. Putting them on different spools and servomotors would double the total number of spools and servos needed, as well as requiring the servomotors to be in synchronized motion. Having both lines on a single spool simplifies the system and removes a potential mode of failure.

Various cam shapes were tried to achieve a single layer spool that allowed both the tensor and extensor cable to be wound up simultaneously, but in the end two stacked circles of differing radii for each finger proved to be the best solution. Each spool was designed to be able to reel a specific amount of line to move each individual finger. The amount of required displacement

was determined by measuring the displacement of Kevlar line that occurred when the hand went from an open position to a closed position. This measurement was done on each group member; an average was taken and used for the calculation of spool diameter for each finger (Appendix E). This calculation for the spool diameters was done using the arc length equation:

$$s = r\theta \quad \text{EQ. 1}$$

s – Displacement of Kevlar line for a specific finger

r – Radius of spool for specific finger

θ – 200 degree revolution of servomotors

After testing, a 2x factor was added to the diameters to allow for a further range of motion and more tensioning capabilities. Therefore, the spool could be rotated to different positions to generate various displacements and tensions. The resulting displacements and spool sizes can be seen in Table 2.

Table 2 | Finger cable displacements and spool sizing.

Finger	Average Displacement Flexion (cm)	Spool Diameter Flexion (cm)	Average Displacement Extension (cm)	Spool Diameter Extension (cm)
Pinky	8.223	9.423	2.434	2.789
Ring	10.192	11.679	3.704	4.245
Middle	10.605	12.152	3.281	3.760
Index	9.493	10.878	2.858	3.274
Thumb	6.223	7.131	2.434	2.789

Due to the fact that the servomotors revolve 200°, a twenty degree offset was implemented to where the Kevlar line attached to the spools. This twenty degree offset allowed for the Kevlar line to always be in tension when on the spool and to leave the spool tangent; allowing for maximum force to transfer from the servomotors to the line, illustrated in Figure 29 and Figure 30.

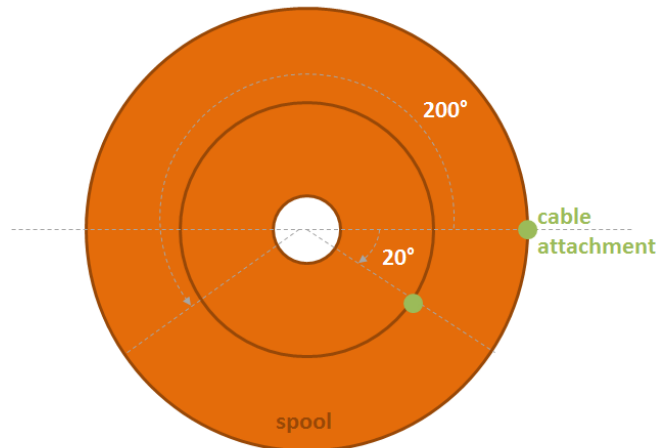

Figure 29 | Diagram of cable attachment points along the spools. There is a 20° offset between the extensor and flexor cable points in order to account for the 200° arc motion of the servomotors.

The cable spool design went through three iterations. The first iteration of the design was sandwiched layers of 0.080 inch acrylic disks, cut to different radii to displace the string the correct length. The design proved the concept of different displacements, but was not a reliable construction. The thickness of the plastic and the strength of the adhesive used did not fully support the device and made them very brittle.

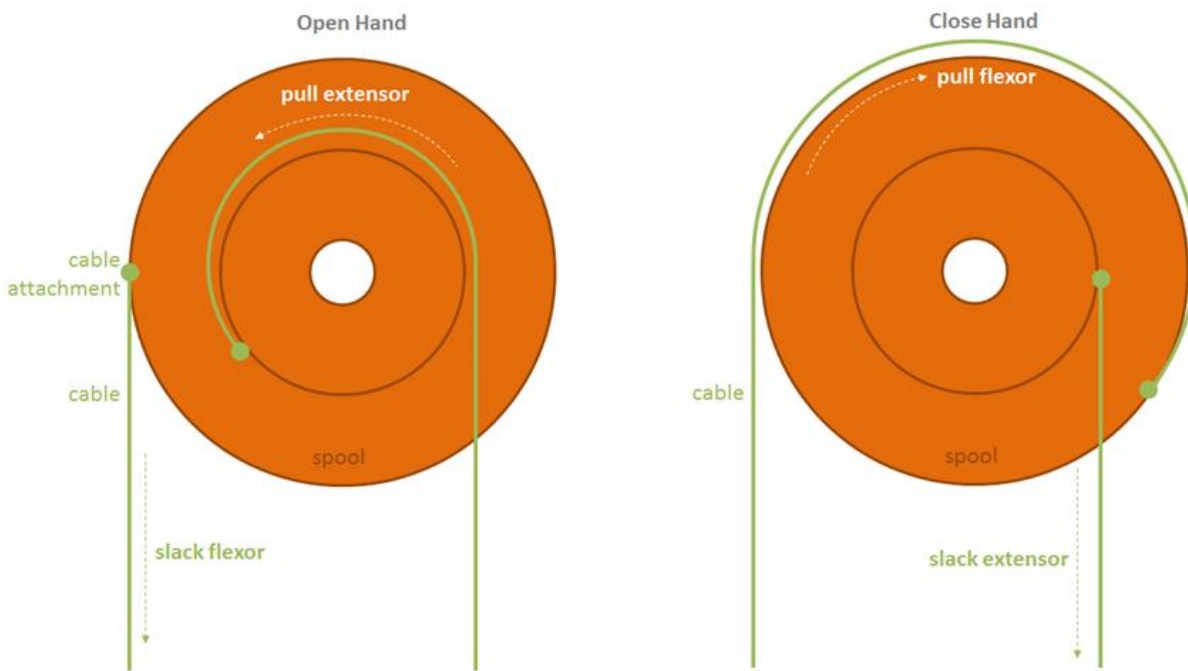

Figure 30 |The top layer of the spools pulls the extensors for opening the hand. When extending the fingers, the extensor cables are slacked and vice-versa for the flexion of the fingers.

The second and third renditions of the spools were both rapid-prototyped parts made of solid a single piece which were more sturdy and reliable (Figure 31). These pieces were attached to the servomotors and were effectively tested.



Figure 31 | Two-Layered spool design cross-section. Top diameter for flexion, bottom diameter for extension of the fingers.

In testing it was discovered that the cables kept falling out of their designated tracks and were becoming caught underneath the spool, causing jamming and lack of tension. Plastic guards were made and positioned around each spool in order to prevent the cable from slipping out of the spools during actuation, see Figure 32.

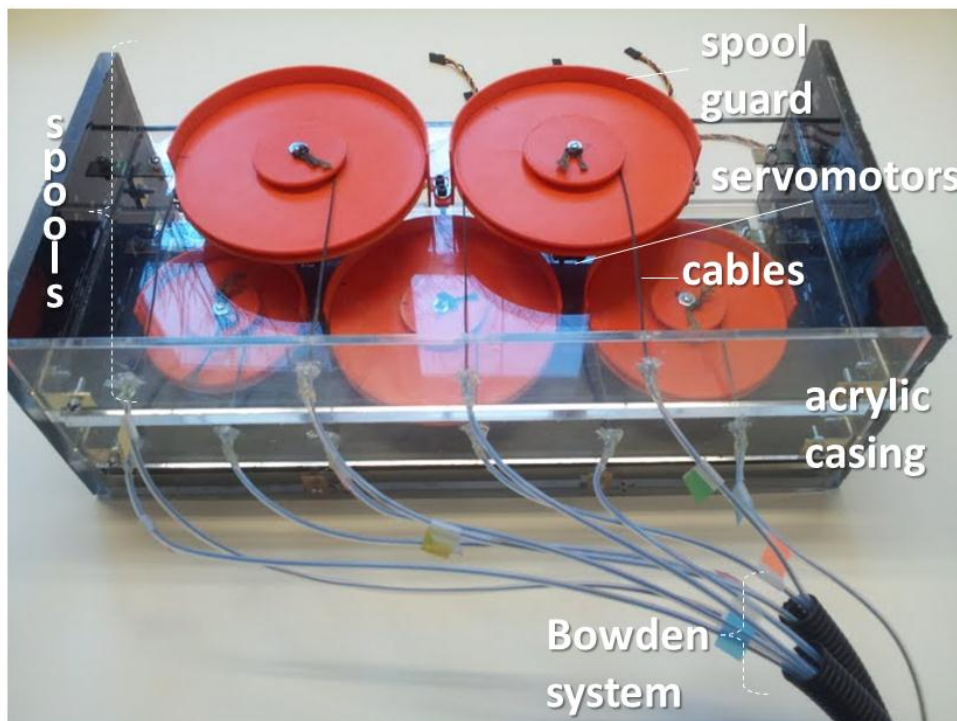

Figure 32 | The servomotors are housed in the backpack within an acrylic unit. The servomotors connect to the electronics and microcontroller, also in the backpack. The spools are guarded to prevent cable slipping. Each spool is sized according to the finger it must displace; the middle-finger spool is the largest and the pinky-finger the smallest. The Kevlar line attached to the spools passes through a rigid slot before entering the Bowden cable system which connects spools to the glove.

5.1.8. Quick Release Mechanism

The prevention of hyperextension and hyperflexion of the fingers was an initial safety consideration, and so an optional quick-release forearm guide was developed (but not implemented in the final design). It was determined that the most effective way to have a mechanical safeguard integrated into the system was to establish a breakable connection point between the cables coming from the hand and the cables coming from the servomotors. Having a mechanical breakpoint at this junction in the system, would allow for an immediate release of tension on the hand with no damage to the servomotors. It was constructed so that each connection established, between each digit, would slide on its own individual bottom-rail, as well as a solid top-rail. When released the top-rail would open the connection point (Figure 33). If a problem would arise, the user would simply have to pull a pin and the spring loaded system would open. With the system open the connection point between the two different cable lines opens, breaking the connection.



Figure 33 | Quick release mechanism locked (top). Pin released (bottom).

With this concept in mind the team started on the physical design. After a few renditions of SolidWorks models (Appendix F), prototype parts were printed. Miniature H-beams, springs, quick release pin and drive shafts were purchased for the clamps to slide on. All of the other parts were created using a rapid-prototyping 3D printer. With all the parts in hand, sanding of certain areas on printed parts was required, as certain thicknesses could not be achieved due to limitations in rapid-prototyping. After the first prototype was completed an evaluation was done

to determine the effectiveness of the mechanism. Modifications to the model were made such as adjusting the compression of the spring, spacing between rails, and adding points for the Bowden cable system to connect. In the end it was determined that the system was a redundant safety feature, and so was not implemented in the final design.

5.1.9. Forearm Cable Guide

In the final design, where the servomotors were configured to not displace enough cable to cause injury, an alternative to the quick-release mechanism was designed. Two, rigid, forearm cable guides were constructed using 3D rapid prototyping. The entire forearm system contains two of these straight guides with cable holes, one on the dorsal side of the forearm, and one on the ventral side. These forearm guides are attached via hook-and-loop strips to a soft, elastic, cotton sleeve which is worn on the forearm. The sleeve serves to hold the forearm guide in place as well as to keep the electrodes (placed under the sleeve, against the arm) at a tight contact with the skin. The main function of the forearm guides was to act as a safeguard between the junction of cables from the servomotors to the cables from the glove, and to allow the cables to be pulled straight along the long axis of the forearm. At this connection point the cables were able to be adjusted in tension. This was done by tying double skip-knots where the two cables joined, using plastic connectors (as seen in Figure 35) The connection pieces between the cables were laser-cut acrylic rectangles, with two holes on either side where the cable lines were strung through. This was done so that the cable lines would not slip on each other from direct knotting.



Figure 34 | Forearm cable guides serves as the connection point between glove and Bowden system. Here the cables can be adjusted for individual tension. Note there is one on the dorsal side of the arm and one

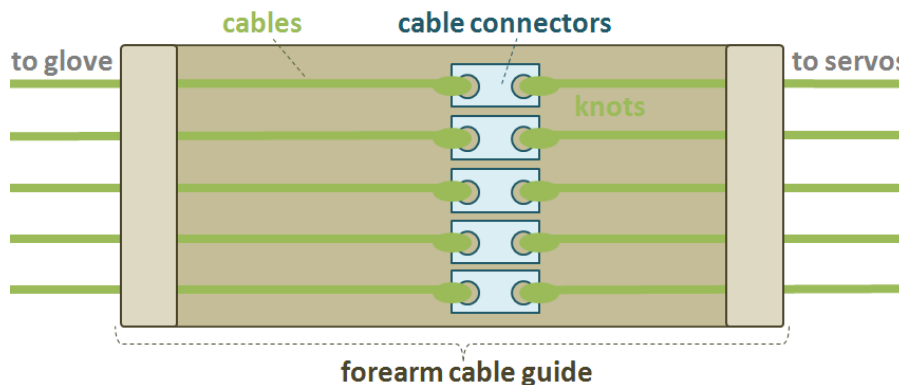

Figure 35 | Forearm cable guide diagram: the forearm cable guide is slotted at either end to allow the cables to run through it. Cables are tied together through a plastic connector piece.

5.1.10. Servomotors

Various actuators were evaluated in order to find one that could serve as a smooth and low power solution for finger articulation. Digital servomotors were chosen (HiTec HS-5645MG) and mounted in a backpack in order to drive the fingers through Bowden cables. Servomotors were chosen for their precise position and current-force control capabilities. The servomotors selected are capable of applying the same



Figure 36 | HiTec HS-5645MG servomotors used for their high torque

forces (~15N) that the average user, within the targeted age range, can produce in gripping everyday objects. Mechanically the servomotors provide a torque of 10.6 kg/cm depending on the current and voltage applied. This torque was sufficient in order to actuate the fingers. Another advantage is the size and form factor of the servomotor compared to a standard electric motor. The compact size, square shape, and screw holes allow for ease of mounting. The revolution limitation of the servomotors can be seen as both an advantage and disadvantage. The advantage is, that if the cable spools are calibrated correctly, the system will be unable to hyperextend or hyperflex the users' hand. The disadvantage is that this restricts the range of users by hand size and can lead to a limited range of motion.

5.2. Electrical Subsystem

A custom circuit board was designed to interface with a microprocessor board so that the glove could be operated. The circuit (Figure 37) consists of signal processing, servomotor control (current limiting), and power.

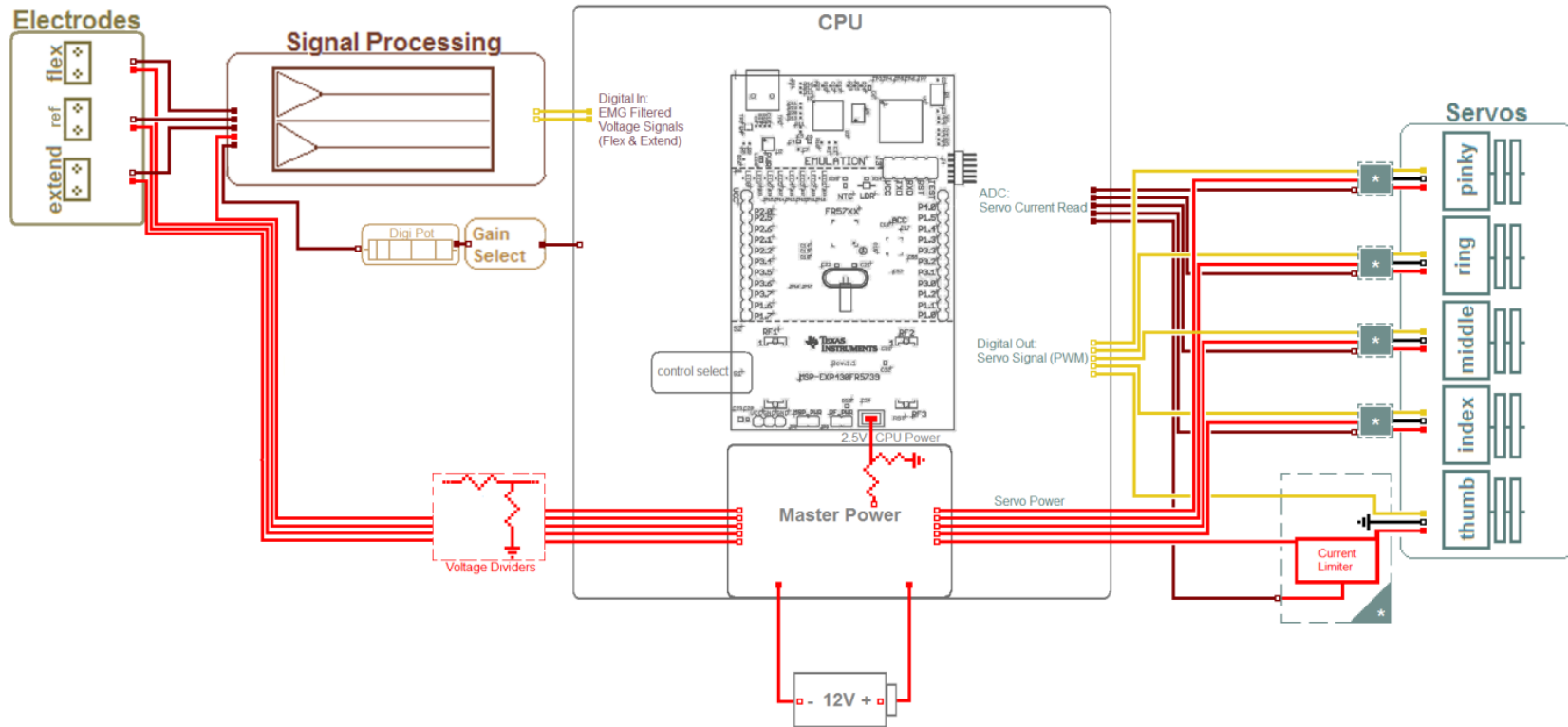

Figure 37 | System diagram with microcontroller in center. Electrodes connect to microcontroller through a signal conditioning circuit. Servomotors are current limited by the microcontroller. 12V power for system operation

All of the op amps, digital potentiometers, and the 3-to-8 decoder had decoupling capacitors placed on the board next to them to help with noise. The signal conditioning portion of the board is powered by a battery pack that provides a 12V and a -12V rail. The servomotors and the MSP430 are powered by a separate +6V battery pack due to the amount of current they draw. A switch board, for user inputs, was also created and consists of: a toggle switch, a 3 switch dip switch, and a resistor dividing network that drops down the +12V so the digital inputs of the MSP430 would not be damaged.

5.2.1. Myoelectric Control Signal Conditioning

EMG was collected from the forearm, specifically the extensor digitorum communis and the flexor digitorum profundis, as detailed in Figure 38. This was done by placing a bipolar surface electrode-amplifier on the skin above each muscle and a reference electrode on the bony part of the elbow. In effect there is an electrode-amplifier for the flexion signal, and an electrode-amplifier for the extension signal, and an electrode as a reference. Utilizing the power of the flexion and extension signals, the glove can be controlled based upon the user's intent to flex/extend.

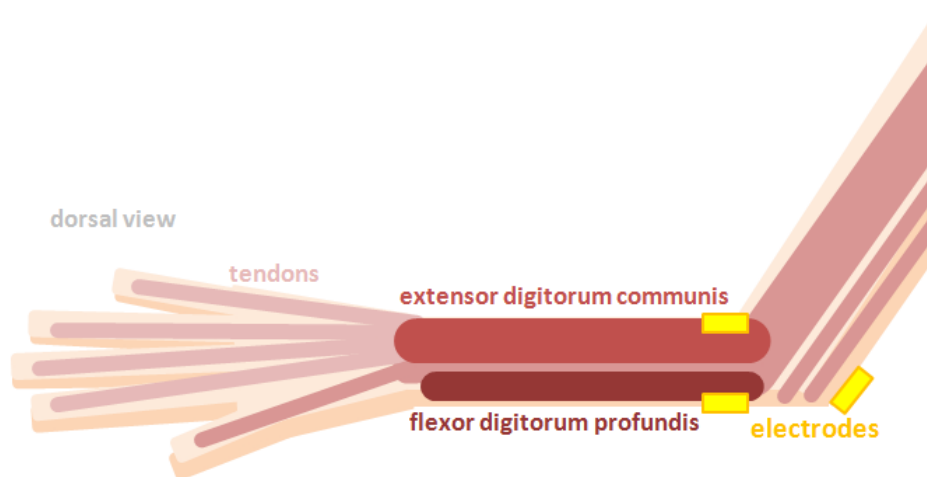

Figure 38 | Major hand flexor and extensor muscles where myoelectric control electrodes were placed.

To keep out motion-based noise a signal conditioning circuit was implemented. The signal conditioning design was based on the work of Edward Clancy²⁹, and simplified for the purposes of this project. Two second-order Butterworth filters were designed, a high-pass and a low-pass. Originally a built-in gain of 10 on the low pass filter was used, but after several failed attempts, (where simulations worked but test circuits failed) it was decided to use two separate gain stages

²⁹ (Clancy 2011)

as well as the two filters. The high pass filter was designed to pass anything above 10Hz and the low pass filter anything below 750Hz. The digital conditioning circuit is diagramed in Figure 39.

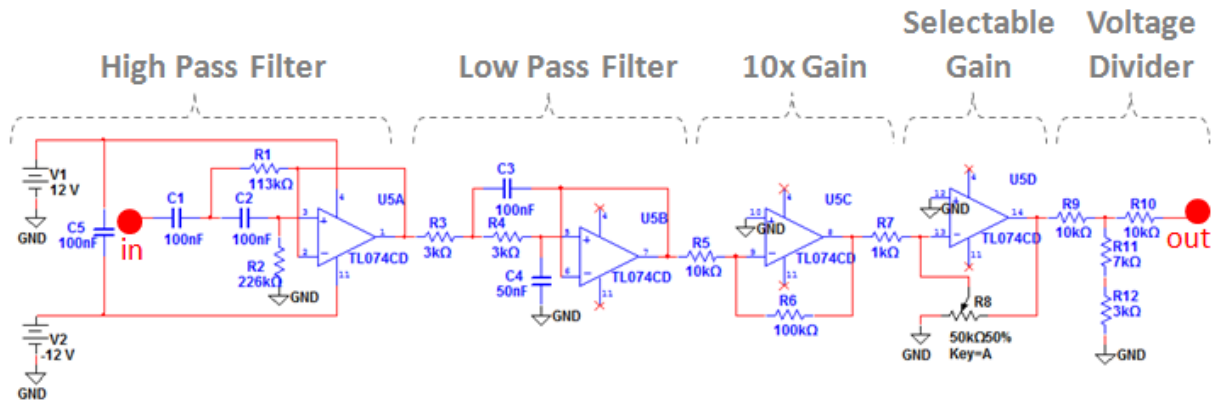

Figure 39 | Signal conditioning circuit diagram. The input is from the electrode-amplifiers and the output connects to the ADC on the microcontroller board.

Originally the conditioning circuit was designed so that it cascaded from the high pass filter, to low pass filter, to gain of 10, and then a to selectable gain (which uses a digital potentiometer to go from a gain of 1 to a gain of 50). However, based on Professor Clancy’s advice the cascade order was changed to: high pass filter, gain of 10, selectable gain, and then low pass filter. This change was made because having the low pass filter last produces the least amount of electronic noise. The last part of this circuit was a resistor network which shifted the 12V to -12V signal to be a 3.6V to 0V signal so that the ADC on the MSP430 wouldn’t be damaged. Once the signal conditioning circuit was created, testing was done in order to produce the Bode plots below, as seen in Figure 40 and Figure 41.

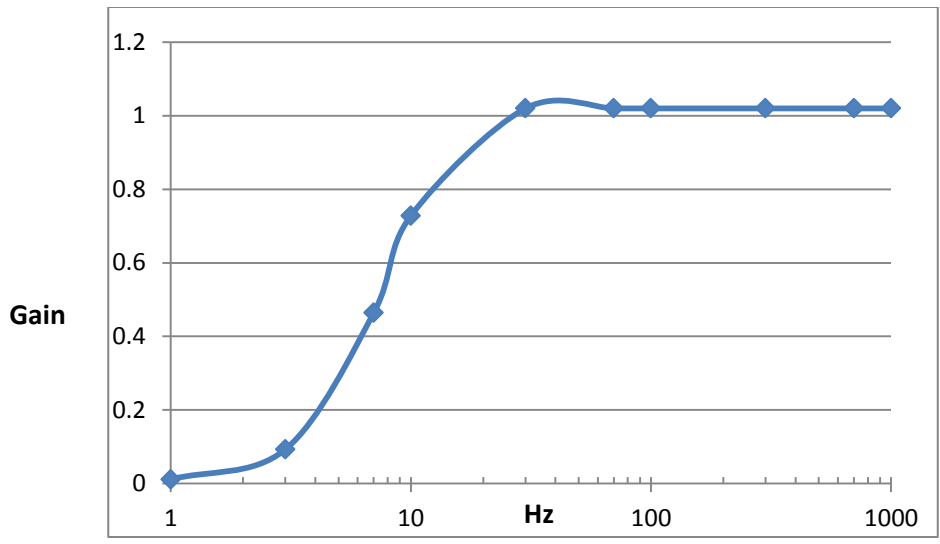

Figure 40 | 2nd Order Butterworth High Pass Filter, $F_c=10\text{Hz}$, $G=1$

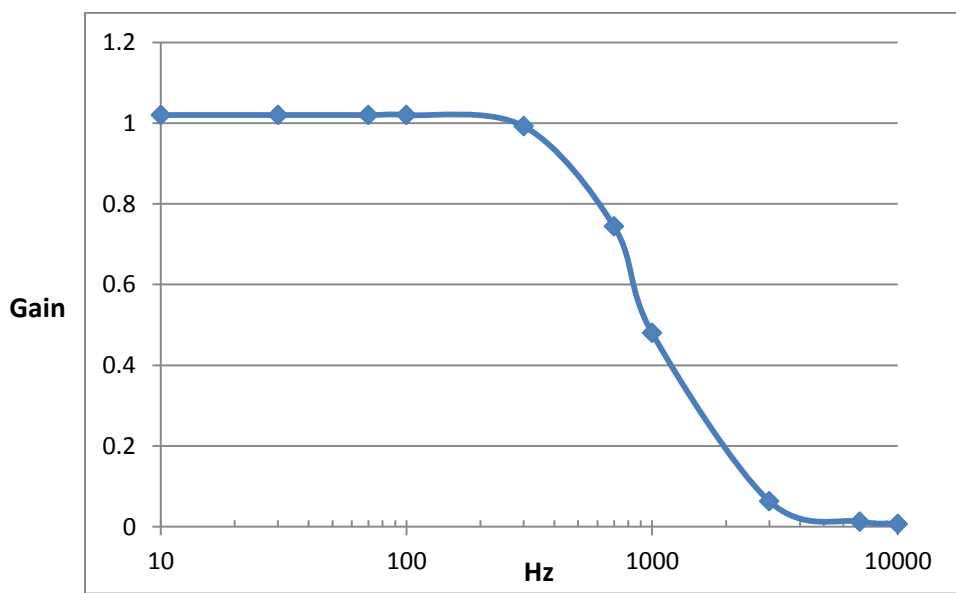

Figure 41 | 2nd Order Butterworth Low Pass Filter, $F_c=750\text{Hz}$, $G=1$

5.2.2. Servomotor Current Limiting Circuit

The next part of the board that was designed was the adjustable current limiters for the servomotors. The aim was to be able to control just how much assistance or resistance the servomotors would be providing people when using the EMG mode of the glove. Therefore the microcontroller needed a way to adjust how much current the servomotors could be allowed to draw. One solution was a fairly simple one-transistor design; however that design would've required a digital potentiometer that could go lower, and be more finely tuned, than anything commercially available. So the next solution shifted to a four-transistor design that was capable of setting the limit over the range of 0.7A to 0.1A by using a 20K Ω digital potentiometer and a 5W, 6.2 Ω current sense resistor that was chosen in order to handle the high voltage and high current flow. However, after consultation with Professor Emanuel (WPI, Electrical Engineering Department) a completely different design was implemented, where the current is limited based on whether or not the servomotor has power. This type of circuit is referred to as a chopping circuit and it only allows the servomotor power when the value of the potentiometer is lower than sections of a generated triangle wave, serving as an analog PWM.

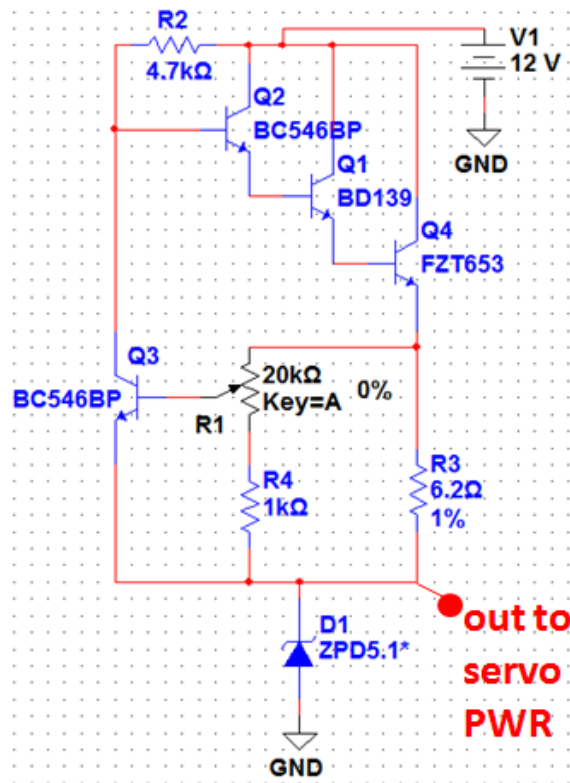

Figure 42 | Current Limiting Circuit Version 1

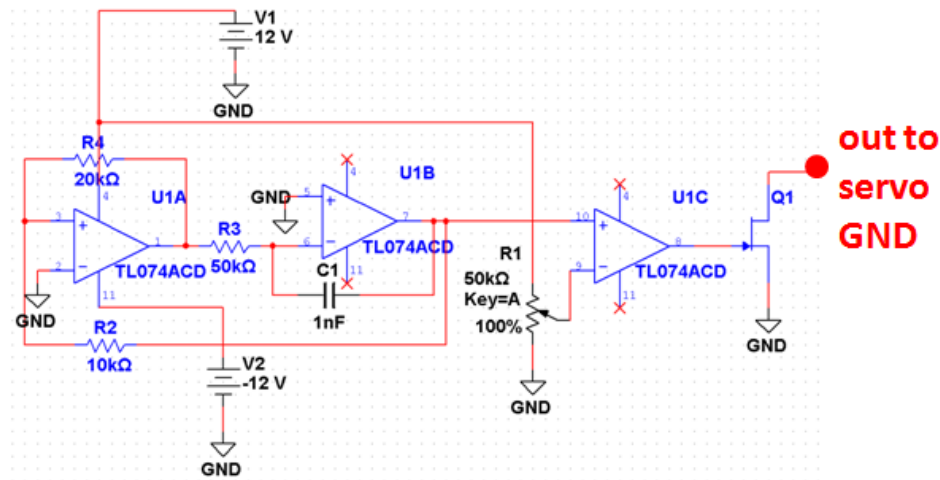

Figure 43 | Current Limiting Circuit Version 2

The only other part of the board was an address decoder that allowed the MSP430 to select each digital potentiometer without needing 8 digital outputs.

5.2.3. Microcontroller

The MSP430FR5739 Experimenter Board (Texas Instruments) was chosen as the microcontroller because it met some key specifications. Namely, it needed to have at least 8 general I/O pins, a built-in ADC capable of sampling at, or above 2KHz, at least 3 ADC pins, and SPI capability. The MSP430 was selected over the other options not only because it met the specifications, but various members of the team had worked with other MSP430s in the past and the experimenter board had spare I/O for future expansions.

5.3. Software

The glove was programmed with C code on the IAR Embedded Workbench, the platform recommended by TI. In developing the code for the glove, the first decision was to determine what functionality was most critical for the device. To determine this, the team considered the three main control modes as seen in Figure 44: switch-activated, EMG-activated, and program. The switch-activated mode used a three-position toggle switch to open, close, or initialize the hand position. The EMG-activated control used the flexor and extensor EMG readings from the forearm to determine whether or not the person is trying to open or close their hand, and how much torque assistance is necessary. The program mode demonstrates the glove's dexterity by opening and closing the entire hand and then opening and closing individual fingers (any similar regimen). With this in mind it was clear that the key component was our ability to control the servomotors.

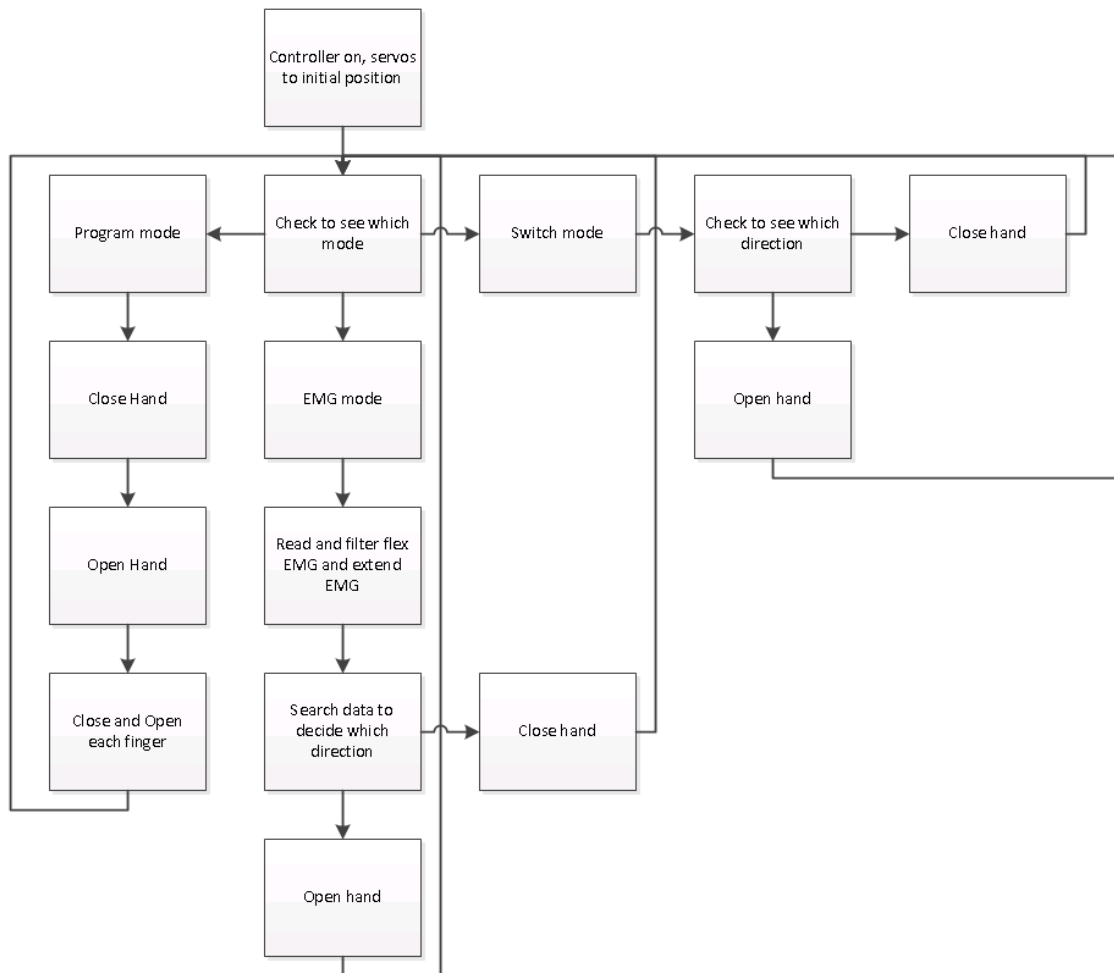

Figure 44 | First the control system waits to see which mode is selected. Switch mode waits to see which way it's toggled, then activates the hand. EMG mode gathers and searches the flex and extend data, once it has enough it decides whether to open or close the hand. Program mode simply runs whatever preset therapy has been selected.

5.3.1 Pulse-width Modulation

The first piece of code the team developed was the Pulse-width Modulation (PWM) code. Referencing the servomotors data sheet the team determined the appropriate duty cycles to achieve the full range of motion for the servomotors. The servomotors have a range of motion of approximately 200° , therefore when the high point of the signal was 0.9ms long, the servomotors would be -100° . When the high portion was 2.1ms long, the servomotors would be at 100° . The simplest way to make this occur was to set up an interrupt that would occur every 0.1ms and have the code count how many interrupts had occurred and turn on and off a digital output pin accordingly. This signal was then sent directly to the servomotors.

5.3.2. Digital Filters

Digital filters were developed in order to better process the EMG signals for control. First, a digital high-pass filter based on Clancy's work³⁰ was developed. This was done with a linear function serving as a low-order finite impulse-response high-pass filter, which utilized three iterative input values (x_n):

$$y_n = 2 * x_n - x_{n-1} - x_{n-2} \quad \text{EQ.2}$$

It would then take the absolute value of this result and use it in a running average (z_n) of the past 512 results.

$$z_n = |y_n| \quad \text{EQ.3}$$

This running average is the filtered output of the EMG signals, functioning as a rectifying low-pass filter. The running average was implemented using a circular buffer (Figure 45) with an array capacity of 512. The most recent 512, z values are averaged and kept as the current voltage reading. The 512 corresponds to the microcontroller's 2KHz sampling rate as well as being a number which works well for this particular EMG application.

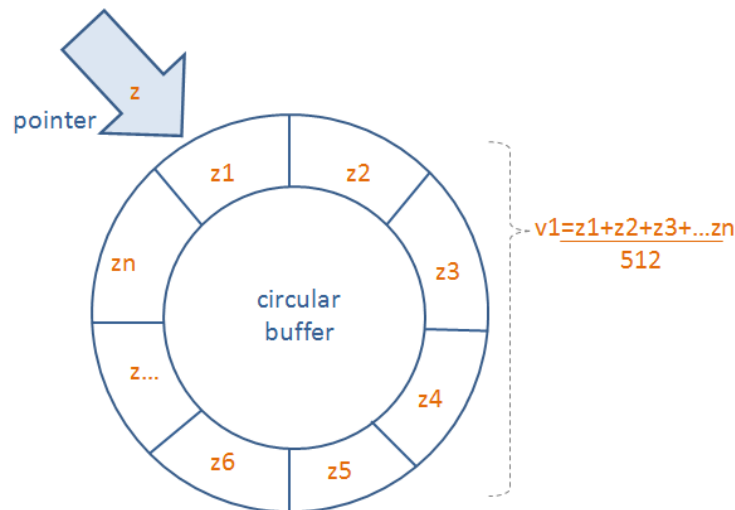

Figure 45 | Conceptual diagram of circular buffer. It is 512-index array which is filled with the z -values of the absolute high-pass filter. The values in the array are used to, calculate a running average, v , which functions as a rectified low-pass filter.

³⁰ (Clancy 2011)

6. Results & Discussion

Overall, the first prototype of the system demonstrates a real working model of the design: a portable solution to hand rehabilitation. With the device, the team was able to effectively articulate all of the fingers on the hand safely. Throughout the course of the testing, the glove demonstrated consistent and repeatable functionality from the mechanical subsystem. In making repairs and adjustments, it was noted that the development of a more modular and accessible servomotor pack would be a much needed benefit for repairs and making adjustments and modifications to the system. Aside from some physical kinks in the Bowden cables, the actuation carried out by the servomotors and spools provided the necessary force to open and close the hand. The Bowden cable system could be improved upon by the use of different material. We found that under an extensive amount of testing that kinks in the tubes began to form. Selecting a more wear resistant, yet still flexible material would be ideal for this task. The Kevlar line used has begun to fray in some places of high friction but had no serious lapse in performance because of it. The forearm cable guides, as well as the arm band have proven to be elegant and effective in their applications of holding the cable in place. As with the rest of the mechanical portion of the system the glove with cables guides has been proven to work but many improvements regarding material, cable guide locations and handicap accessibility can be made to tailor the glove for more dynamic usage.

The implementation of the electrical and software subsystems requires a lot more testing to reach the desired level of functionality. In principle the electrical circuit types that have been used fit the applications they have been chosen for; however their implementation in this project has been undesirable. After two iterations of the electrical control boards, problems were still frequent so the need for a proto-board system was required. In programming the micro processor, compiler software had to be swapped due to memory address issues, which halted a portion of program development time.

6.1. Specifications

The final assembly, including glove, cable, backpack, and servomotors, weighed 13.2 lbs, with the majority of that weight being in the backpack. The components on the arm weigh less than 2lbs. The estimated material cost of the system is 400USD, with 100USD from the custom made spools and 200USD from the servomotors. In manufacturing the device, the cost of the plastic components would decrease significantly though injection molding the parts.

The system is able to sustain itself off independent battery power for over 4hrs. Since the glove has such a simple design it is able maintain operation without serious maintenance for much longer than the battery life.

6.1.1. Grip Force

The maximum tension in the cables and the ensuing grip force were measured using a tension gauge. The maximum tensile force and grip force was 15N. This is enough force for a hand to pick up most common objects. The ability of the glove to grip was tested using a wooden mannequin hand with simple articulating joints as seen in Figure 46.



Figure 46 | Wooden mannequin grip verification test. The glove is equipped on a wooden hand with pin-jointed fingers. The servomotors were actuated to their open and close hand positions and the mannequin hand was flexed and extended.

The mannequin hand proved to not have enough articulation to move naturally but was still actuated by the glove. Testing on human hands was successful. The user's hand could be opened and closed involuntarily. When tensioned, the system allowed for optimal force transfer and

supplied tension in flexion and extension. Moreover the cable flexion resulted in not only closing the user's hand, but also providing grip strength.

6.1.2. Battery Life

For the final design off-the-shelf AA batteries were connected to provide the necessary power supply to each part of the system. There are two unique power systems on the backpack a +12V and a -12V supply for the EMG measurement circuits as well as the switchboard, and a 6V supply for the servos and microcontroller. Due to the extremely low draw from the EMG sensor circuit, there is virtually no current being drawn for the supply (0.01mA). This enables the system to have a long operational battery life; this part of the system can be operated for days at a time without the need to be replaced. The 6V supply has a much higher current draw. The MSP430 continuously draws around 0.25A from the battery pack and when activated the servos can draw at maximum, 0.5A. Under this load of constant operation, the 6V battery pack has a life span of around 4-5 hours. Over all the battery life of the system would be able to last for an effective amount of time for therapy sessions.

6.2. Safety

Since this system would be used on a person, safety was a high concern. The main safety concerns that were considered were hyperextension and hyperflexion as well as electrical isolation. To prevent hyperextension and hyperflexion, the implementation of a quick-release sub-system was considered. This system creates a dynamic connection point between the cables coming off the hand and the cables that are being actuated from the servos. If a sudden need to release tension on the hand would arise, the user could pull a pin breaking the connection between the two thus releasing all tension on the hand. As the design of the system progressed, the implementation of the custom spools accomplished the same goal as the quick-release. Each spool is limited by the rotation of the servo and was designed to operate within these parameters. The only way this can be abused is if the user sets the servo position to closed and then puts their hand in the glove open and tensions it in the open position and then tries to open the glove further. The main safety concern when using electrodes is the possibility of a failure resulting in electrocution. However, the system bypasses this concern by using battery packs instead of connecting to an earth ground.

6.3. Electromyogram Control Calibration

Electrodes were utilized as a means to control the glove with the user's own myoelectric signal (through EMG). This was implemented by placing two electrodes on the forearm, of the hand that was being actuated. One electrode was placed on the dorsal side of the forearm, on the bulky part of the extensor digitorum muscle, which mainly extends the fingers. The second electrode was placed on the flexor digitorum, on the ventral side of the arm. A third electrode was used as reference to cancel out the body's background signal; this electrode was placed above the boney part of the elbow. And so EMG was obtained in two signals, one from the muscle which extends the fingers and one from the muscle that flexes the fingers. A control program was written such that if the hand was closed and the extending EMG reached a certain threshold, the servomotors would open the hand. And conversely if the hand was open and the flexing EMG reached a certain threshold, the servomotors would close the hand.

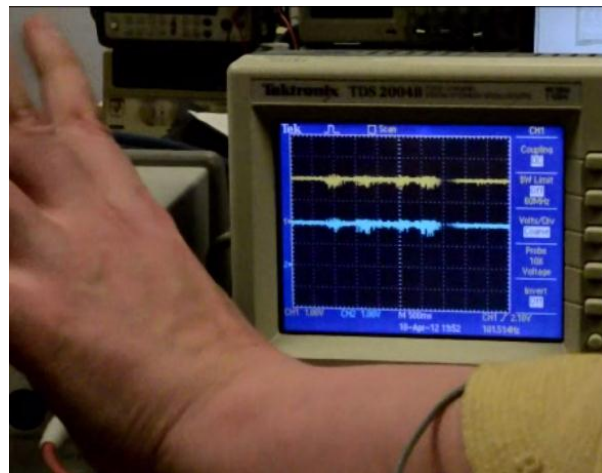

Figure 47 | EMG calibration: using oscilloscope the waveforms of the filtered myoelectric signal can be adjusted in terms of gain in order to make pulses visible. This signal is what the MSP430 would see.

The EMG threshold depends on multiple factors. It is different from person to person depending on the natural power of their EMG; this can be accounted for with the selectable gain of the signal conditioning circuit. The threshold also is determined by how sensitive the control is programmed. There is a somewhat linear relationship in the power of the EMG signal and the amount of force that is being applied by the muscle. This relationship can be used with the current limiting circuit to not only actuate the servomotors, but to also dictate how much force should be applied.

6.4. Pre-tensioning

When readying the system for use, the cables had to be pre-tensioned to optimize actuation. This meant that a taught cable line better transferred motion through the Bowden system. Pre-tensioning occurred at the forearm cable guide where the cables from the servomotors were attached to the cables from the glove. The initial tension was adjusted based on the user's hand size and arm position. The actual tensioning was adjusted by tying more slack into the knots at the forearm guide. Typically the glove was tensioned at the open-hand position so that all cable lines were taught.

Pre-tensioning allowed for adjustments during testing, but future versions of the device could incorporate continuous cable lines, that could be dynamically tensioned.

7. Future Work

The overall goal of producing a lightweight, comfortable, safe and effective prototype was met by this project. However there are many ways that the design can be improved upon. The key improvements that could be implemented to allow for a wider range of users, are creating a custom glove that has discrete guides built in, a dynamic tensioning system, increasing system modularity, and increased accessibility.

7.1. Assistive Applications

The glove device which flexes and extends the fingers can be used not only for rehabilitation but also for assistance. With some adjustments in software control and mechanics, the glove could be worn continuously by people requiring stability and strength. The controls could be implemented to hold the hand in a position, such as open until cued otherwise. In practice this could apply to holding the hand open until an item needs to be grasped. The exposed cables can be covered by a second glove or some sort of rigid cover, in order to avoid entanglement. The glove as an assistive device could be used by persons with multiple sclerosis, arthritis, cerebral injury, traumatic hand injury, or any case which requires aid in how the hand moves.

7.2. Shape Deposition Glove

The glove and cable guides on the exterior of the glove, although effective, inhibit the user from grasping and picking up soft or glossy items such as a phone receiver or soda can. This can be corrected by creating a glove that has all the pieces necessary for movement as part of the actual glove material. Using a higher resolution 3D printer it would be possible to create such a glove. Printers with higher resolution and composite hard and soft material would be a means of creating a single-piece glove with moveable joints and integrated cable guides. This glove could be custom-fit to users who require the glove for assistance more than rehabilitation, since they would wear the glove for extended periods of time.

7.3. Dynamic Tension

The cable tension in the system was key to full actuation. The servomotor motion was better transferred when the cable line was taught. In order to tension the device, each time it was equipped, the cables had to be tightened at the forearm guide junction. This adjustment accounted for the user's physiology as well as position. Tensioning at this junction was effective, but time consuming and imprecise. A method of dynamically tensioning the cables would allow for the cable to always be taught despite user or position.

Such a design would first require sensors to determine whether the line is slack or taught. This could be done in various fashions including linear potentiometers and strain gauges. After the sensing would come some form of physical method to change the slack in the cable line. The simplest solution would be to use motors or 360° servomotors so that the spools could reel in the excess cable line. It is important to note that an actuator capable of reeling in infinite line, would require a fail-safe (such as the quick-release mechanism) in order to prevent hyperextension and hyperflexion.

Overall a dynamic tensioning system or an alternate form of actuation that accounts for the necessary tension, would allow for a more intuitive and useable design.

7.4. Servomotor Casing

The servomotor housing currently protects the servomotors and spools from damage and arranges them so that they fit well in the backpack. Access to them is limited to the back of the housing which is left open to allow for the cabling from the servomotors to lead out to the control board. The only way to gain access to the spools and rest of the servomotors is to disassemble the housing. Improving this design would greatly benefit maintenance and future design changes to the system.

A drawer-like design that would allow for the servomotors to slide in and out would be more accessible. Other options may be to have hinges on certain supports so that they can swing open and allow access to the servomotors. Any of these changes among others would greatly improve access to servomotors without having to disassemble the housing.

A more rigid material or extra supports may also be helpful in the construction of the housing as the current front plate is made out 0.08 inch thick acrylic. This works for the front plate as it doesn't have to support anything, but when the servomotors spool up the Kevlar line, it has a

tendency to bow. A more rigid material or extra supports on the front plate to counteract those forces would improve the performance of the system.

7.5. Accessibility

The glove was designed for persons with hemiparesis and limited hand mobility. These people tend to have difficulty opening their hands, and have rigid fingers; and so for them putting on a glove is a difficult task. Aid from a therapist or care assistant in equipping the robotic glove is one method of making the device accessible. Some recommendations for simplifying this task would be to attach a zipper along the side of the glove in order to have more access to the inside of the glove while putting it on stiff fingers.

Putting on a backpack might be a difficult task for someone that has recently suffered from stroke. Replacing the ordinary backpack straps with clips would allow the user to sit in a chair and have the backpack put on them instead of putting the backpack on.

7.6. Mimic Glove

Expanding upon control options and rehabilitation approaches, the idea of a mimic glove was developed. The mimic glove would be a control glove worn on the user's abled-hand and would mirror the movements from control to robotic glove, in a master-slave control interface. The master mimic glove, could utilize linear potentiometers to determine the angle and position of each finger on the control hand, and the slave robotic glove would follow the position of the master.

This control option would allow for intuitive use, based on existing function of the other hand (in the case of hemiparesis). It could be implemented in real-time for mirror therapy or in a walking-delay approach.

7.7. Functional MRI

This glove also has the potential to be used for research in a functional MRI, as everything from the hand to the shoulder is MRI compatible. Using this in a functional MRI setting would allow for brain mapping while the patient's hand is being manipulated by the device. For the device to be used in an MRI, the method of actuation would have to change due to that fact that the MRI would interfere with the electronics. The suitable replacement actuation method could be pneumatics. The use of pneumatics would allow for variable force control. The force from a pneumatic system could be controlled with pressure regulators and relief valves so that applied force could be limited to prevent injury to a patient.

8. Conclusion

The prototype rehabilitative robotic glove developed by this project met the functional objectives of creating a wearable device that can be utilized for stroke rehabilitation. The device is capable of providing assistance in the flexing and extending of the user's fingers. It can supply a 15N tensile force for this actuation and for grip strength. The cable and guides provide an effective means of delineating the actuation provided by the cables. The Bowden system allows for servomotors or in the future, other actuators, to be worn in a backpack. The spools and servomotors allowed for position and torque control sufficient to move each finger independently and with enough resolution for multiple positions. The control options (switch, program, and myoelectric signal) allow for stroke survivors to rehabilitate through different stages of recovery. The future of this device will continue to aim for a universal design that persons recovering from stroke, or people with other needs, may use for rehabilitation or assistance.



Works Cited

- Abdullah, Hussein, Cole Tarry, Cynthia Lambert, Susan Barreca, and O. Brian Allen. "Results of Clinicians Using a Therapeutic Robotic System in an Inpatient Stroke." *Journal of NeuroEngineering* (BioMed Central) 8, no. 50 (2011).
- Adee, Sarah. "Dean Kamen's "Luke Arm" Prosthesis Ready for Clinical Trials." *IEEE Spectrum*. February 2008. <http://spectrum.ieee.org/biomedical/bionics/dean-kamens-kue-arm-readies-for-clinical-trials> (accessed 2011).
- Bogue, Robert. "Exoskeletons and robotic prosthetics: a review of recent developments." *Industrial Robot: An international Journal*, 2009: 21-427.
- Brassil, Thomas, and John M. Brassil. Hand Rehabilitation Glove. USA Patent 6454682. September 24, 2002.
- Butefisch, Cathrin, Horst Hummelsheim, Petra Denzler, and Karl-Heinz Mauritz. "Repetitive training of isolated movements improves the outcome of motor rehabilitation of the centrally paretic hand." *Journal of the Neurological Sciences* 130 (1994): 59-68.
- Butz, Kent, Greg Merrell, and Eric Nauman. "A biomechanical analysis of finger joint forces and stresses developed during common daily activities." *Computer Methods in Biomechanics and Biomedical Engineering* 1, no. 10 (2011).
- Canning, Colleen G, Louise Ada, Roger Adams, and Nicholas J O'Dwyer. "Loss of strength contributes more to physical disability after stroke than loss of dexterity." *Clinical Rehabilitation* (Sage) 18 (2004): 300-308.
- Carmeli, Eli, Sara Peleg, Gadi Barture, Enbal Elbo, and Jean-Jaques Vatine. "Hand Tutor Enhanced Hand Rehabilitation after Stroke: A Pilot Study." (John Wiley & Sons Ltd.) 2010.
- Cipriani, Christian, Franco Zaccone, Silvestro Micera, and M. Chiara Carrozza. "Prosthetic Hand: Analysis of the User-Prosthesis Interaction." *IEEE Transactions on Robotics* (IEEE) 24, no. 1 (February 2008): 170-184.
- Clancy, Edward (Ted) A. "Design of a High-Resolution, Monopolar, Surface Electromyogram (EMG) Array Electrode-Amplifier and its Associated Signal Conditioning Circuit." Department of Electrical and Computer Engineering, Department of Biomedical Engineering, Worcester Polytechnic Institute, Worcester, MA 01609 U.S.A., 2011.
- Day, Scott. *Important Factors in Surface EMG Measurement*. Calgary, AB: Bortec Biomedical, 2011.
- DEKA. *iBot*. n.d. <http://www.dekaresarch.com/ibot.shtml> (accessed 2011).
- Granata Design Limited. "CES EduPack 7.0." Cambridge, 2011.

- Groh, David. "Electromyography Instrumentation." Las Vegas: University of Nevada, n.d.
- Jugenheimer, Kristin Anne. "A Robot for Hand Rehabilitation." Thesis, Masters of Science, Massachusetts Institute of Technology, Cambridge, 2001.
- Lang, Catherine E., and Mare H. Schieber. "Human Finger Independence: Limitations due to Passive Mechanical Coupling Versus Active Neromuscular Control." *Journal of Neurophysiology* 92 (2004): 2802-2810.
- Mathiowetz, Virgil, Nancy Kashman, Gloria Volland, Karen Weber, and Mary Dowe. "Grip and Pinch Strength: Normative Data for Adults." Occupational Therapy Program, University of Wisconsin, Milwaukee, 1985.
- National Stroke Association. "Muscle Weakness after Stroke: Hemiparesis." North Star Neuroscience, 2006.
- Ng, Serena, Mary Chu, Anna Wu, and Peg Cheung. "Effectiveness of Home-based Occupational Therapy for Early discharged Patients with Stroke." *Hong Kong Journal of Occupational Therapy* 15 (2005): 27-36.
- Ochoa, Mauricio J, Yicheng Jia, Dev Narasimhan, and Derek G. Kamper. "Development of a Portable Actuated Orthotic Glove to Facilitate Gross Extension of the Digits for Therapeutic Training after Stroke." *31st Annual International Conference of the IEE EMBS*. Minneapolis, Minnesota, USA, 2009. 6918-6921.
- Oujamaa, L., I. Relave, J. Froger, D. Mottet, and J.-Y. Pelissier. "Rehabilitation of arm function after stroke. Literature Review." *Annals of Physical and Rehabilitation Medicine* (Elsevier Masson) 52 (2009): 269-293.
- Richards, Lorie G., Nancy k. Latham, Diane U Jette, Lauren Rosenberg, Randall J. Smout, and Gerben DeJong. "Characterizing Occupational Therapy Practice in Stroke Rehabilitation." *Arch Phys Med Rehabil* 86 (2005): S51-60.
- Salini, Christian A, John A Tranquilli, and Punit Prakash. "Design of Instrumentation for Recording the Electromyogram." Independent Study Project, Department of Electrical and Computer Engineering, Worcester Polytechnic Institute, 2003.
- Ueki, Satoshi, et al. "Development of a Hand-Assist Robot With Multi-Degrees-of-Freedom for Rehabilitation Therapy." *IEEE/ASME Transactions on Mechatronics*, 2010.

Appendix A: List of Acronyms

ADC- analog to digital converter

EMG- electromyography

FIR- finite impulse response

I/O- input and output

MAV- mean absolute value

MRI- magnetic resonance imaging

MQP- Major Qualifying Project

PWM- pulse-width modulation

RC- remote control

WBS- work breakdown structure

WPI- Worcester Polytechnic Institute

Appendix B: Work Breakdown Structure

Initial work breakdown structure for design project.

- 1 **Lit review**
 - 1.1 **First Draft**
 - 1.2 **Second Draft**
- 2 **Background research**
 - 2.1 **Forces of the Hand**
 - 2.2 **Kinematics of the hand**
- 3 **Budget**
- 4 **Preliminary Design review**
 - 4.1 **List all possible ideas**
 - 4.2 **Comparison Chart (Pick top 3)**
 - 4.3 **Have solid models of options**
 - 4.4 **New comparison chart to fully evaluate**
- 5 **Final Design/Design Review**
 - 5.1 **Develop specifications**
 - 5.1.1 **Motors/Actuators/Drives**
 - 5.1.2 **EMG**
 - 5.1.3 **Controller**
 - 5.1.4 **Part Placement**
 - 5.1.5 **Material Selection**
- 6 **Prototyping/Construction**
 - 6.1 **Construct "Forearm"**
 - 6.1.1 **Fabricate glove elements**
 - 6.1.2 **Support for electronics**
 - 6.1.3 **Assemble glove**
 - 6.2 **EMG Data Collection**
 - 6.2.1 **Signal processing (logic/hardware)**
 - 6.3 **Development of controller framework**
 - 6.3.1 **Input signal interpretation**
 - 6.3.2 **Develop output signals to motors**
- 7 **Testing**
 - 7.1 **Response time**
 - 7.2 **Test grip strength**
 - 7.3 **Safety Testing**
 - 7.4 **Mechanical Durability**
- 8 **Final Paper**

Appendix C: Gantt Chart Excerpt

Excerpt of project Gantt chart, listing work break down structure, basic task responsibility, and timeline.

#	Tasks	Owner	A Term																			
			9/21/11	9/22/11	9/23/11	9/24/11	9/25/11	9/26/11	9/27/11	9/28/11	9/29/11	9/30/11	10/1/11	10/2/11	10/3/11	10/4/11	10/5/11	10/6/11	10/7/11	10/8/11	10/9/11	10/10/11
1	Lit review	CM																				
1.1	First Draft	PG,MD,SF,CM																				
1.2	Second Draft	PG,MD,SF,CM																				
2	Background research	PG,MD,SF,CM																				
2.1	Forces of the Hand	CM																				
2.2	Kinematics of the hand	CM																				
3	Budget	PG,MD,SF,CM																				
4	Preliminary Desgin review																					
4.1	List all possible idea	All																				
4.2	Comparison Chart (Pick top 3)	All																				
4.3	Have solid models of options	PG,MD																				
4.4	New comparison chart to fully evaluate																					
5	Final Design/Design Review																					
5.1	Develop specifications																					
5.1.1	Motors/Actuators/Drives	MD																				
5.1.2	EMG	CM																				
5.1.3	Controller	MD																				
5.1.4	Part Placement	PG,MD																				
5.1.5	Material Selection	PG																				
6	Prototyping/Construction																					
6.1	Construct "Forearm"	PG																				
6.1.1	Fabricate glove elements																					
6.1.2	Support for electronics																					
6.1.3	Assemble glove																					
6.2	EMG Data Collection	CM																				
6.2.1	Signal processing (logic/hardware)	CM,SF																				
6.3	Development of controller framework	SF																				
6.3.1	Input signal interpretation	SF,CM																				
6.3.2	Develop output signals to motors	SF,MD																				
7	Testing																					
7.1	Response time	CM,SF																				
7.2	Test grip strength	MD																				
7.3	Safety Testing	MD																				
7.4	Mechanical Durability	PG																				
8	Final Paper	PG,MD,SF,CM																				

Appendix D: Linear Responsibility Chart

Task	WBS	M. Delph	S. Fischer	P. Gauthier	C. Martinez L.	G. Fischer	T. Clancy	Client	Key
1	Lit review	R	R	R	A	C	I	C	<i>A</i> <i>Accountable</i>
1.1	First Draft	R	R	R	R	C	I	O	<i>R</i> <i>Responsible</i>
1.2	Second Draft	R	R	R	R	C	I	O	<i>C</i> <i>Consulted</i>
2	Background research	A	A	A	A	C	I	O	<i>I</i> <i>Informed</i>
2.1	Forces of the Hand	R	I	R	A	I	I	C	<i>O</i> <i>Out of the Loop</i>
2.2	Kinematics of the hand	R	I	R	A	I	I	C	
3	Budget	A	R	R	R	R	C	O	
4	Preliminary Design review	A	A	A	A	C	C	C	
4.1	List all possible ideas	R	R	R	R	C	C	C	
4.2	Comparison Chart (Pick top 3)	R	R	R	R	C	C	C	
4.3	Have solid models of options	R	R	A	R	C	C	C	
4.4	New comparison chart to fully evaluate	R	R	R	R	C	C	C	
5	Final Design/Design Review	A	A	A	A	A	A	C	
5.1	Develop specifications	R	R	R	R	I	I	O	
5.1.1	Motors/Actuators/Drives	A	C	A	C	C	C	O	
5.1.2	EMG	I	I	I	A	I	C	O	
5.1.3	Controller	C	A	I	I	C	I	O	
5.1.4	Part Placement	A	R	A	R	C	I	O	
5.1.5	Material Selection	R	R	R	R	C	I	O	
6	Prototyping/Construction	A	A	A	A	C	C	O	
6.1	Construct "Forearm"	I	I	A	I	I	I	O	
6.1.1	Fabricate glove elements	R	R	R	R	C	C	O	
6.1.2	Support for electronics	R	R	I	I	C	C	O	
6.1.3	Assemble glove	A	R	A	R	C	I	O	
6.2	EMG Data Collection	I	R	I	A	I	C	O	
6.2.1	Signal processing (logic/hardware)	R	A	I	R	C	C	O	
6.3	Development of controller framework	A	R	R	I	C	I	O	
6.3.1	Input signal interpretation	R	A	I	A	C	C	C	
6.3.2	Develop output signals to motors	A	A	R	I	C	I	O	
7	Testing	A	A	A	A	C	C	O	

Appendix E: Cable Displacement Measurements

Individual 1 Flexion		Individual 2 Flexion		Individual 3 Flexion		Individual 4 Flexion	
Finger	Displacement (cm)	Finger	Displacement (cm)	Finger	Displacement (cm)	Finger	Displacement (cm)
Pinky	7.938	Pinky	9.525	Pinky	9.366	Pinky	6.985
Ring	10.478	Ring	12.065	Ring	11.906	Ring	6.985
Middle	11.271	Middle	11.430	Middle	11.430	Middle	9.366
Index	8.890	Index	10.478	Index	10.319	Index	9.049
Thumb	5.715	Thumb	5.080	Thumb	8890	Thumb	5.080

Individual 5 Flexion		Flexion			
Finger	Displacement (cm)	Finger	Average Displacement (cm)	Spool Diameter (cm)	Mass (kg)
Pinky	7.303	Pinky	8.223	9.423	2.568
Ring	9.525	Ring	10.192	11.679	2.072
Middle	9.525	Middle	10.605	12.152	1.991
Index	8.731	Index	9.493	10.878	2.225
Thumb	6.350	Thumb	6.223	7.131	3.394

Individual 1 Extension

Finger	Displacement (cm)
Pinky	2.540
Ring	3.175
Middle	2.540
Index	2.858
Thumb	2.223

Individual 2 Extension

Finger	Displacement (cm)
Pinky	2.223
Ring	4.128
Middle	3.493
Index	2.858
Thumb	2.540

Individual 5 Extension

Finger	Displacement (cm)
Pinky	2.540
Ring	3.810
Middle	3.810
Index	2.858
Thumb	2.540

Extension

Finger	Average Displacement (cm)	Spool Diameter (cm)	Mass (kg)
Pinky	2.434	2.789	8.676
Ring	3.704	4.245	5.701
Middle	3.281	3.760	6.437
Index	2.858	3.274	7.391
Thumb	2.434	2.789	8.676

Torque at 6 Volts
(kg*cm)

12.1

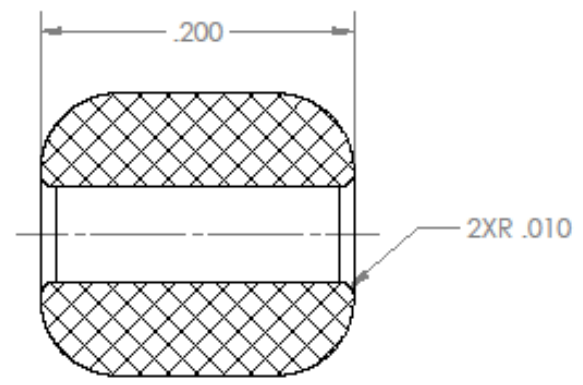
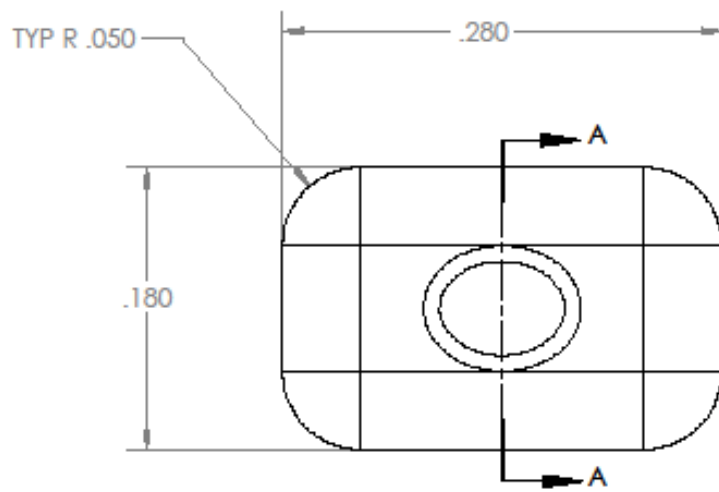

SECTION A-A

PROPRIETARY AND CONFIDENTIAL
 THE INFORMATION CONTAINED IN THIS DRAWING IS THE SOLE PROPERTY OF <INSERT COMPANY NAME HERE>. ANY REPRODUCTION IN PART OR AS A WHOLE WITHOUT THE WRITTEN PERMISSION OF <INSERT COMPANY NAME HERE> IS PROHIBITED.

		UNLESS OTHERWISE SPECIFIED:		NAME	DATE	TITLE: CABLE GUIDE PALM	
		DIMENSIONS ARE IN INCHES		DRAWN	PG		3/7/2012
		TOLERANCES:		CHECKED			
		FRACTIONAL ±		ENG APPR.			
		ANGULAR: MACH ± BEND ±		MFG APPR.			
		TWO PLACE DECIMAL ±		G.A.			
		THREE PLACE DECIMAL ±		COMMENTS:			
		INTERPRET GEOMETRIC TOLERANCING PER:					
		MATERIAL:					
NEXT ASSY		USED ON					
APPLICATION		DO NOT SCALE DRAWING		SIZE A DWG. NO. M121-002 REV 1			
				SCALE: 10:1 WEIGHT:		SHEET 1 OF 1	

5

4

3

2

1

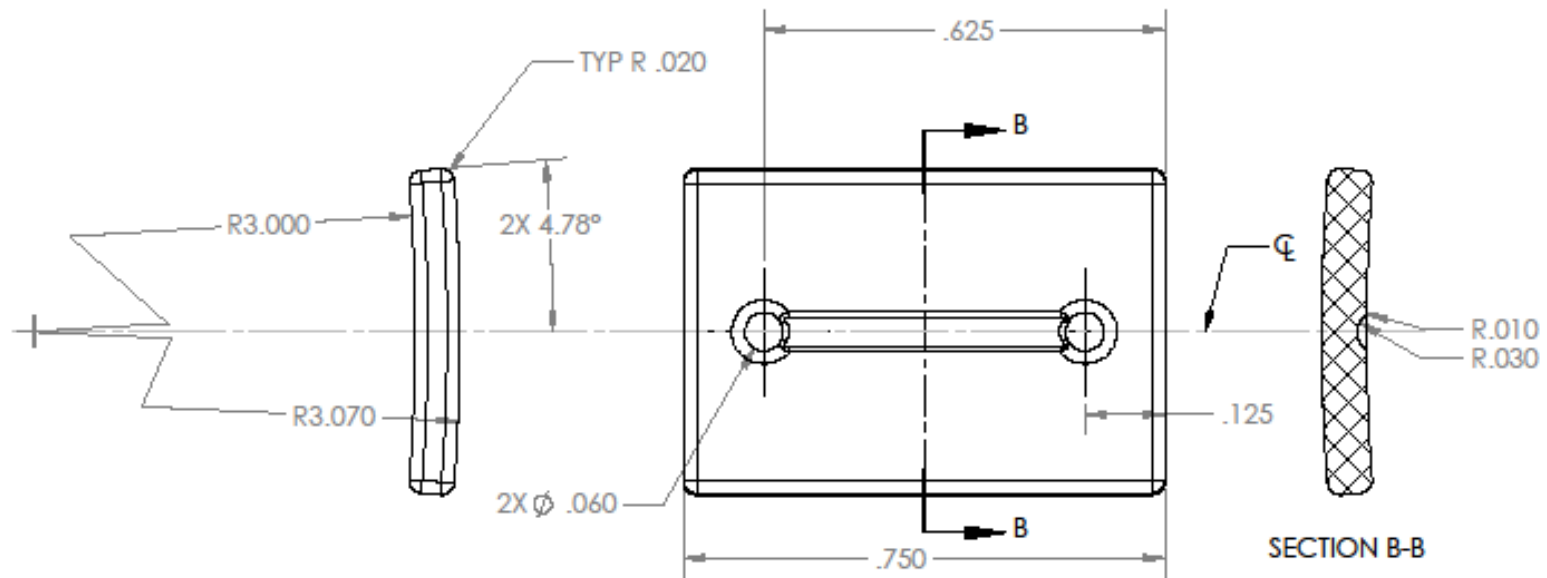

PROPRIETARY AND CONFIDENTIAL
 THE INFORMATION CONTAINED IN THIS DRAWING IS THE SOLE PROPERTY OF <INSERT COMPANY NAME HERE>. ANY REPRODUCTION IN PART OR AS A WHOLE WITHOUT THE WRITTEN PERMISSION OF <INSERT COMPANY NAME HERE> IS PROHIBITED.

		UNLESS OTHERWISE SPECIFIED:		NAME	DATE			
		DIMENSIONS ARE IN INCHES		DRAWN	PG	3/7/2012		
		TOLERANCES:		CHECKED			TITLE:	
		FRACTIONAL ±		ENG APPR.			CAP BACK FINGER	
		ANGULAR: MACH ± BEND ±		MFG APPR.			SIZE DWG. NO. REV	
		TWO PLACE DECIMAL ±		Q.A.			A M121-003 1	
		THREE PLACE DECIMAL ±		COMMENTS:			SCALE: 4:1 WEIGHT: SHEET 1 OF 1	
		INTERPRET GEOMETRIC TOLERANCING PER:						
		MATERIAL:						
NEXT ASSY		USED ON						
APPLICATION		DO NOT SCALE DRAWING						

5

4

3

2

1

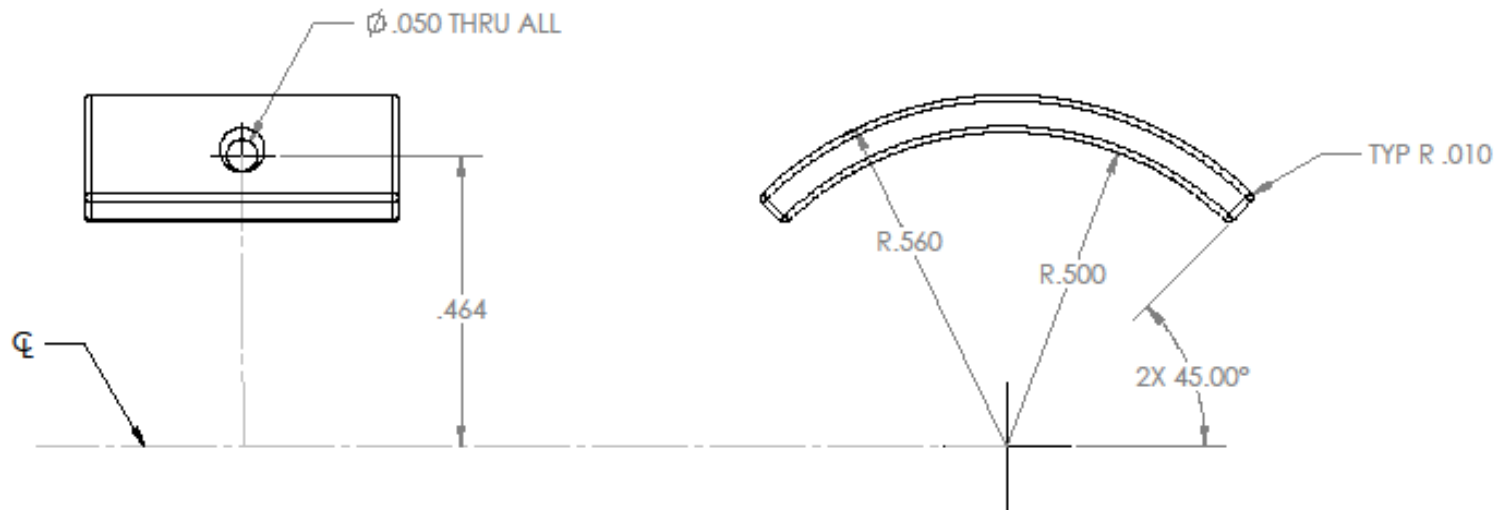

PROPRIETARY AND CONFIDENTIAL
 THE INFORMATION CONTAINED IN THIS DRAWING IS THE SOLE PROPERTY OF <INSERT COMPANY NAME HERE>. ANY REPRODUCTION IN PART OR AS A WHOLE WITHOUT THE WRITTEN PERMISSION OF <INSERT COMPANY NAME HERE> IS PROHIBITED.

		UNLESS OTHERWISE SPECIFIED:	NAME	DATE	
		DIMENSIONS ARE IN INCHES	DRAWN	PG	3/7/2012
		TOLERANCES:	CHECKED		
		FRACTIONAL \pm	ENG APPR.		
		ANGULAR: MACH \pm BEND \pm	MFG APPR.		
		TWO PLACE DECIMAL \pm	Q.A.		
		THREE PLACE DECIMAL \pm	COMMENTS:		
		INTERPRET GEOMETRIC TOLERANCING PER:			
		MATERIAL:			
		FINISH:			
NEXT ASSY	USED ON				
APPLICATION		DO NOT SCALE DRAWING			
			TITLE:		
			CAP FINGER		
SIZE	DWG. NO.	REV			
A	M121-004	1			
SCALE: 4:1	WEIGHT:	SHEET 1 OF 1			

5

4

3

2

1

8 7 6 5 4 3 2 1

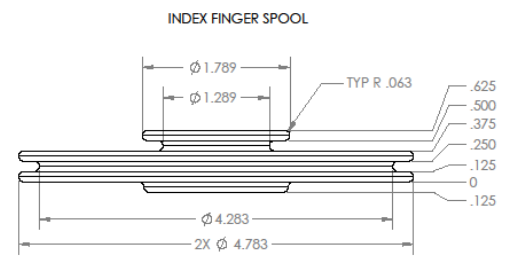

ALL DIMENSIONS ARE THE SAME EXCEPT FOR THE MAJOR DIAMETERS OF THE SPOOLS

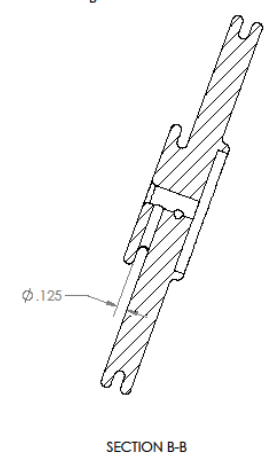
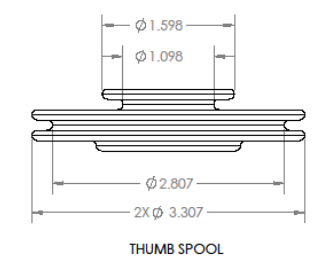
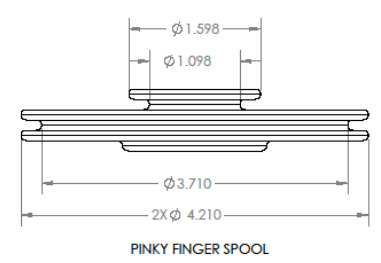
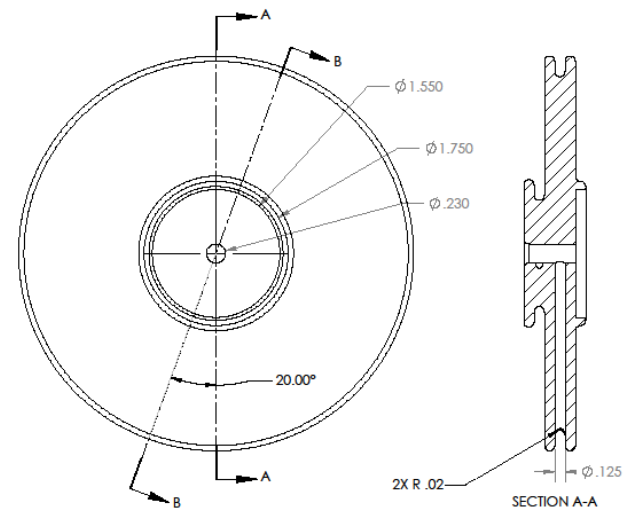
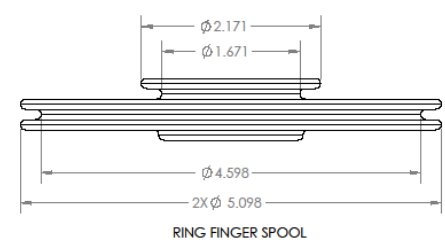
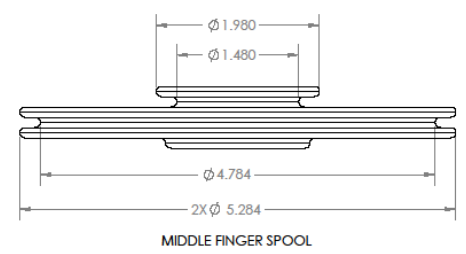

PROPRIETARY AND CONFIDENTIAL
 THE INFORMATION CONTAINED IN THIS DRAWING IS THE SOLE PROPERTY OF HARBRE COMPANY NAME HERE. ANY REPRODUCTION IN PART OR AS A WHOLE WITHOUT THE WRITTEN PERMISSION OF HARBRE COMPANY NAME HERE IS PROHIBITED.

		UNLESS OTHERWISE SPECIFIED:		NAME	DATE
		DIMENSIONS ARE IN INCHES		DRAWN	PG 3/7/2012
		TOLERANCE:		CHECKED	
		FRACTIONAL ±		ENG APPR.	
		ANGULAR: MACH: BEND ±		MFG APPR.	
		TWO PLACE DECIMAL ±		Q.A.	
		THREE PLACE DECIMAL ±		COMMENTS:	
		HARBRE GEOMETRIC TOLERANCING PER:			
		MATERIAL:			
		FINISH:			
NEXT ASSY:	USED ON:	APPLICATION:			
		DO NOT SCALE DRAWING			
				TITLE:	
				SPOOLS	
		SIZE DWG. NO.	REV		
		C M121-005	1		
		SCALE: 1:1	WEIGHT:	SHEET 1 OF 1	

8 7 6 5 4 3 2 1

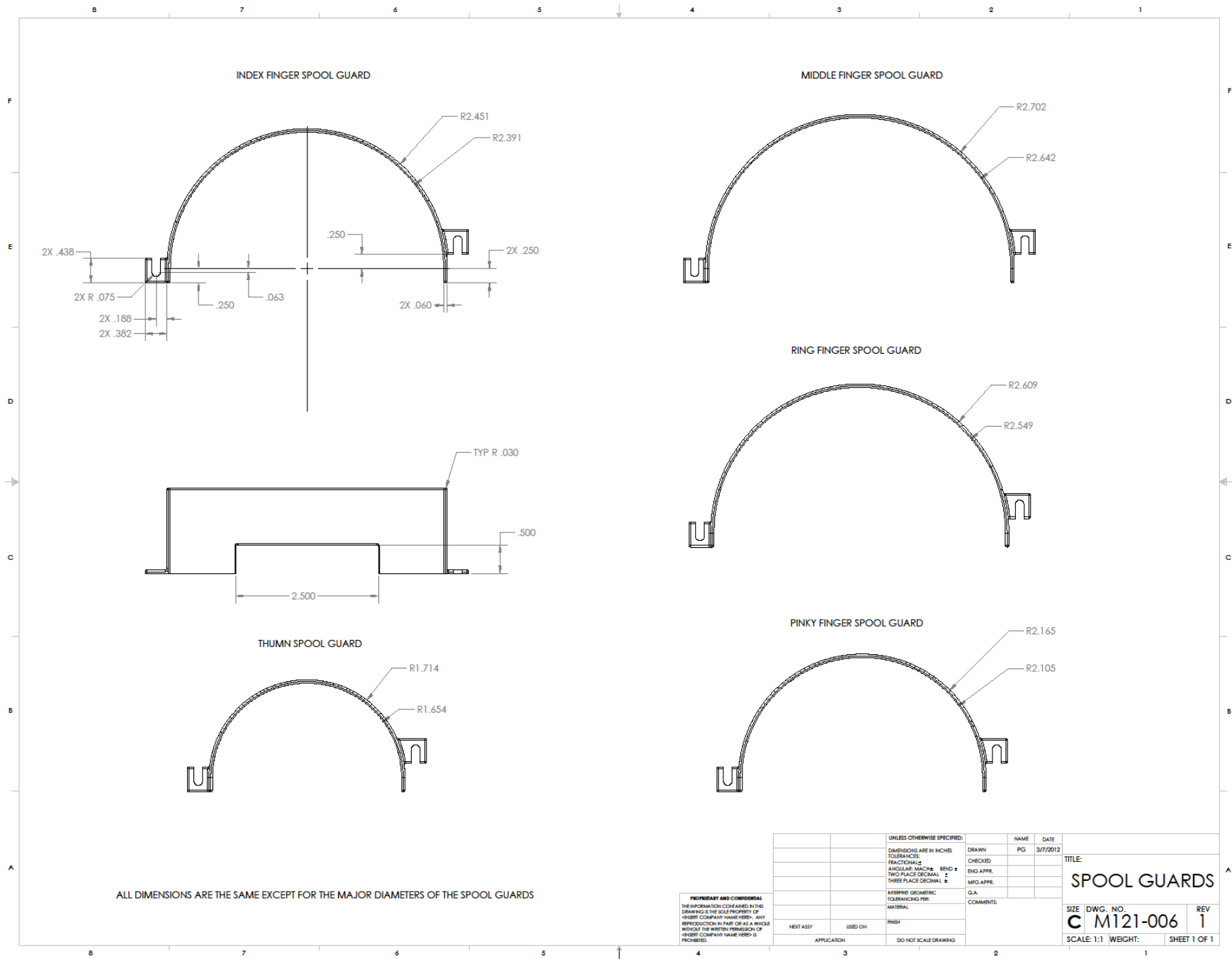

PROPRIETARY AND CONFIDENTIAL
 THE INFORMATION CONTAINED IN THIS DRAWING IS THE SOLE PROPERTY OF HENSEL COMPANY NAME HEREIN. ANY REPRODUCTION IN PART OR AS A WHOLE WITHOUT THE WRITTEN PERMISSION OF HENSEL COMPANY NAME HEREIN IS PROHIBITED.

UNLESS OTHERWISE SPECIFIED:		NAME	DATE
DIMENSIONS ARE IN INCHES	TOLERANCES:	DRAWN	PG
FRACTIONAL	±		3/7/2012
ANGULAR	MACH	CHECKED	
TWO PLACE DECIMAL	BOND #	ENG APPR:	
THREE PLACE DECIMAL		MFG APPR:	
		G.A.	
		COMMENTS:	
NEXT ASSY	USED ON		
APPLICATION	DO NOT SCALE DRAWING		

TITLE:	
SPOOL GUARDS	
SIZE	DWG. NO.
C	M121-006
SCALE: 1:1	WEIGHT:
	SHEET 1 OF 1

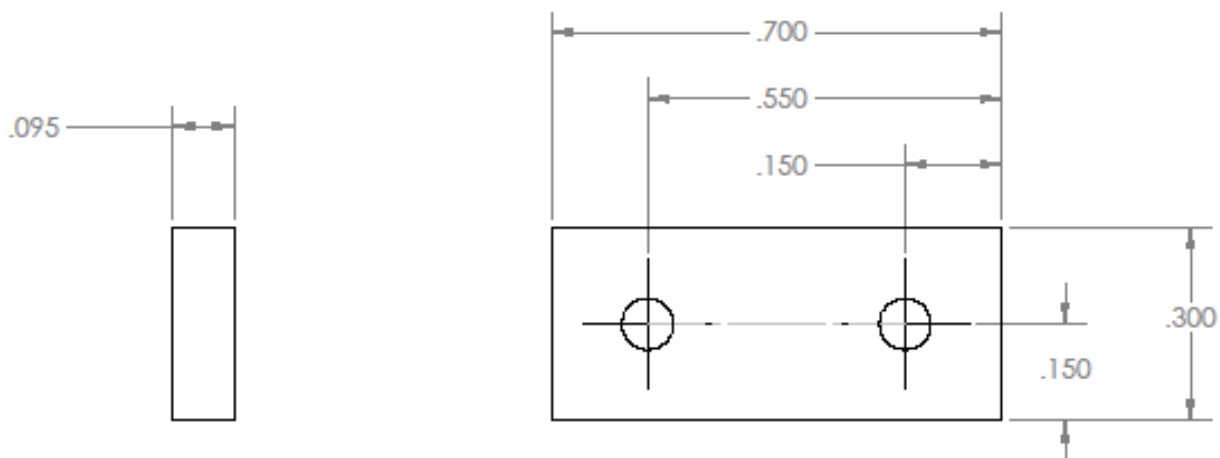

PROPRIETARY AND CONFIDENTIAL
 THE INFORMATION CONTAINED IN THIS DRAWING IS THE SOLE PROPERTY OF <INSERT COMPANY NAME HERE>. ANY REPRODUCTION IN PART OR AS A WHOLE WITHOUT THE WRITTEN PERMISSION OF <INSERT COMPANY NAME HERE> IS PROHIBITED.

		UNLESS OTHERWISE SPECIFIED:		NAME	DATE	TITLE: CABLE CONNECTOR
		DIMENSIONS ARE IN INCHES	DRAWN	PG	4/23/12	
		TOLERANCES: FRACTIONAL ± ANGULAR: MATCH ± BEND ± TWO PLACE DECIMAL ± THREE PLACE DECIMAL ±	CHECKED			
		INTERPRET GEOMETRIC TOLERANCING PER:	ENG APPR.			
		MATERIAL	MFG APPR.			
		FINISH	Q.A.			
NEXT ASSY	USED ON		COMMENTS:			
APPLICATION		DO NOT SCALE DRAWING				SIZE DWG. NO. REV A M121-007 1
						SCALE: 4:1 WEIGHT: SHEET 1 OF 1

5 4 3 2 1

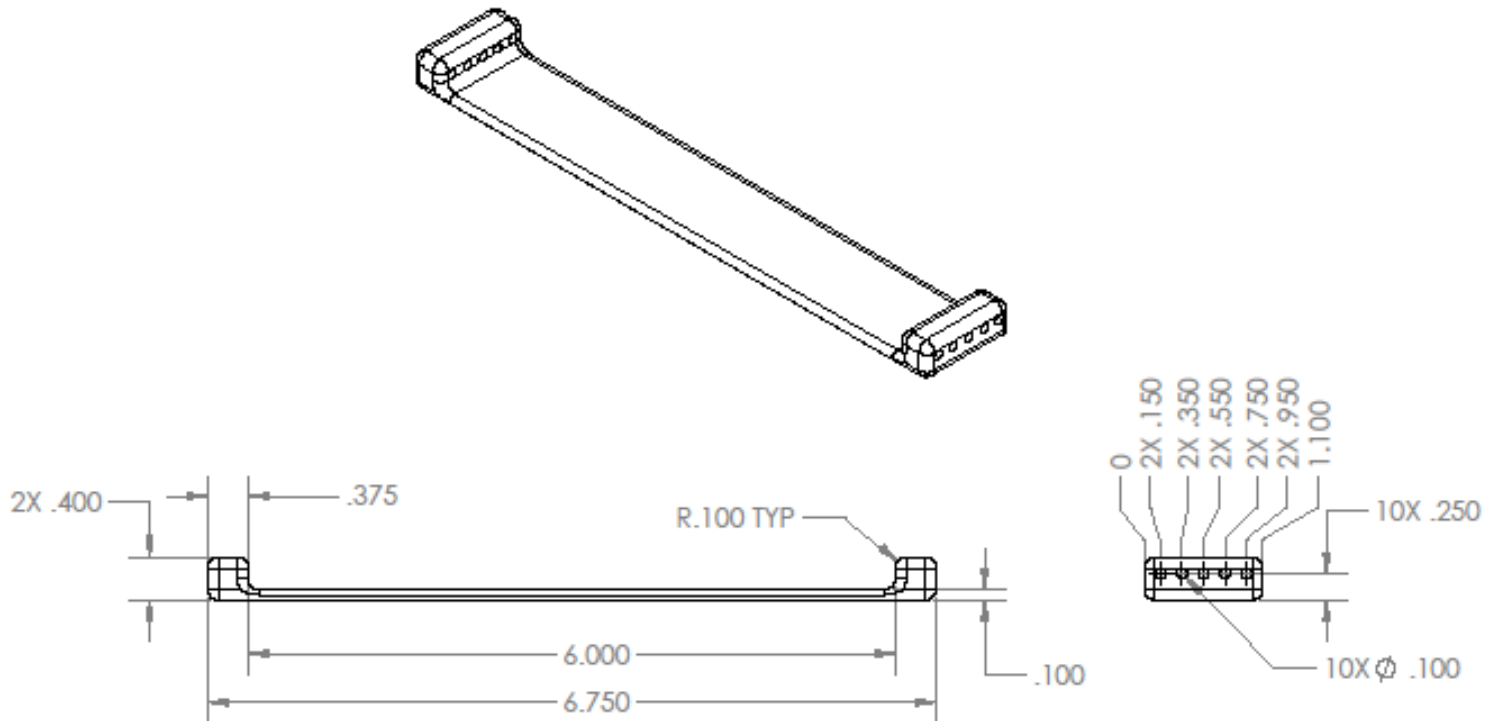

PROPRIETARY AND CONFIDENTIAL
 THE INFORMATION CONTAINED IN THIS DRAWING IS THE SOLE PROPERTY OF <INSERT COMPANY NAME HERE>. ANY REPRODUCTION IN PART OR AS A WHOLE WITHOUT THE WRITTEN PERMISSION OF <INSERT COMPANY NAME HERE> IS PROHIBITED.

		UNLESS OTHERWISE SPECIFIED:	NAME	DATE	TITLE: FOREARM CABLE GUIDE	
		DIMENSIONS ARE IN INCHES	DRAWN	PG		4/23/12
		TOLERANCES: FRACTIONAL ±	CHECKED			
		ANGULAR: MACH ± BEND ±	ENG APPR.			
		TWO PLACE DECIMAL ±	MFG APPR.			
		THREE PLACE DECIMAL ±	Q.A.			
		INTERPRET GEOMETRIC TOLERANCING PER:	COMMENTS:			
		MATERIAL				
		FINISH				
NEXT ASSY	USED ON					
APPLICATION		DO NOT SCALE DRAWING				
5	4	3	2	1		
		SIZE DWG. NO.		REV		
		A M121-008		1		
		SCALE: 1:1.5		WEIGHT:	SHEET 1 OF 1	

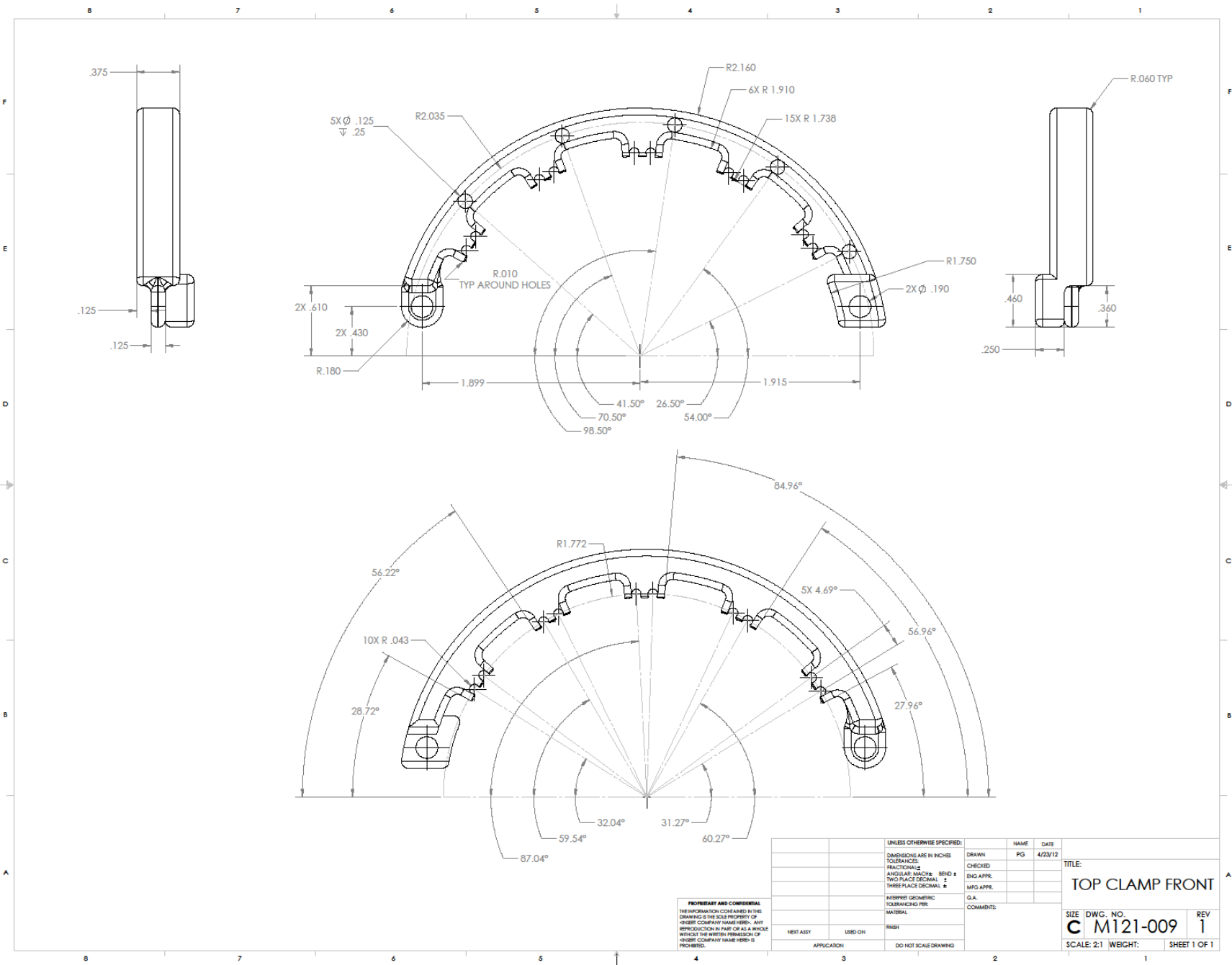

PROPRIETARY AND CONFIDENTIAL
 THE INFORMATION CONTAINED IN THIS DRAWING IS THE SOLE PROPERTY OF HENSEL COMPANY NAME HERE. ANY REPRODUCTION IN WHOLE OR AS A WHOLE WITHOUT THE WRITTEN PERMISSION OF HENSEL COMPANY NAME HERE IS PROHIBITED.

UNLESS OTHERWISE SPECIFIED:		NAME	DATE
DIMENSIONS ARE IN INCHES	TOLERANCES:	DRAWN	PG
FRACTIONAL	DECIMAL	CHECKED	4/23/12
ANGULAR	MACH. FINISH	ENG. APPR.	
TWO PLACE DECIMAL	1	INFO APPR.	
THREE PLACE DECIMAL	2	D.A.	
INTERPRET GEOMETRIC TOLERANCING PER:		COMMENTS:	
MATERIAL:			
FINISH:			
NEXT ASSY:	USED ON:		
APPLICATION:	DO NOT SCALE DRAWING		

TITLE:
TOP CLAMP FRONT

SIZE DWG. NO. REV
C M121-009 1
 SCALE: 2:1 WEIGHT: SHEET 1 OF 1

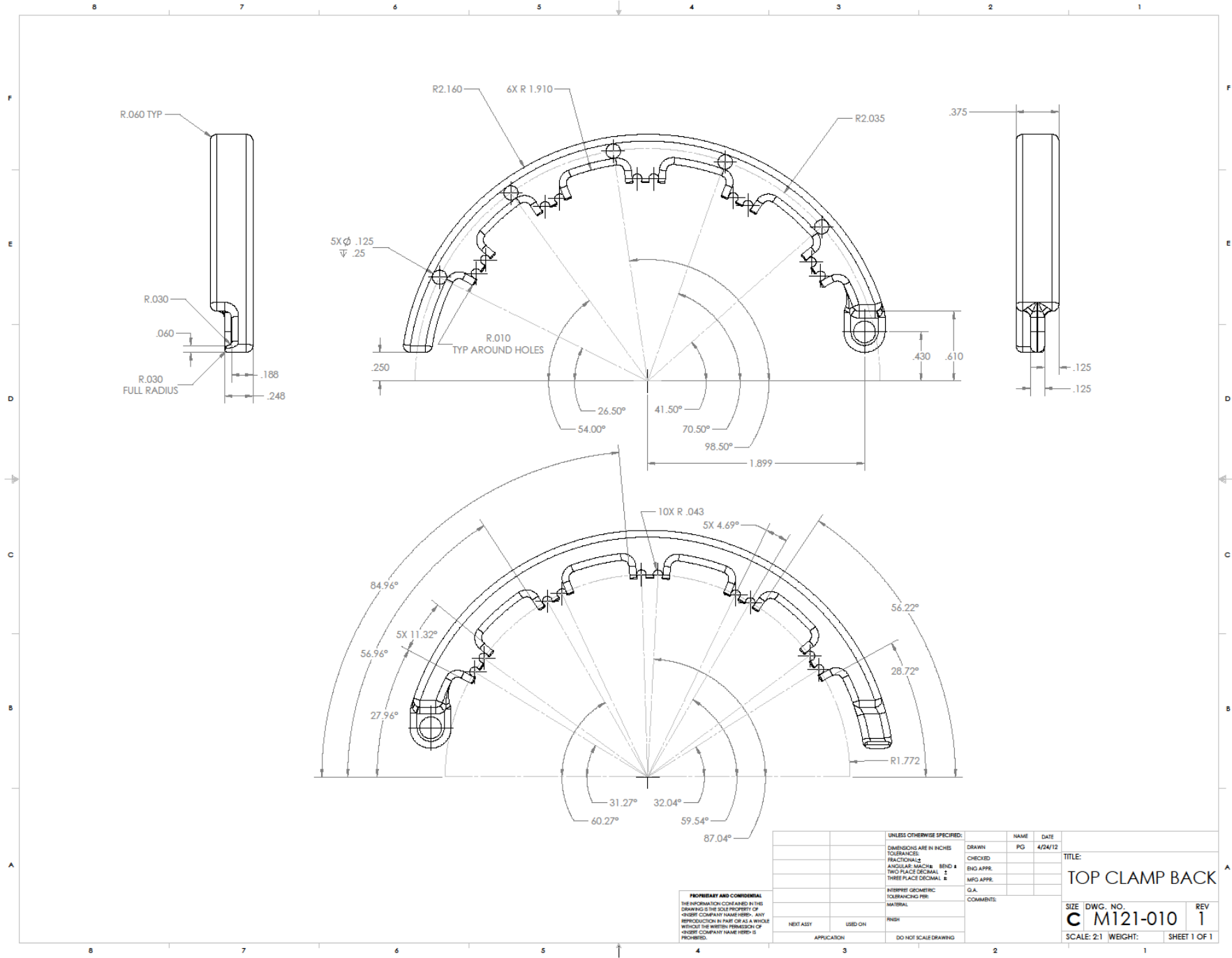

PROPRIETARY AND CONFIDENTIAL
 THE INFORMATION CONTAINED IN THIS DRAWING IS THE SOLE PROPERTY OF ©ORBIT COMPANY NAME HERE. ANY REPRODUCTION IN PART OR AS A WHOLE WITHOUT THE WRITTEN PERMISSION OF ©ORBIT COMPANY NAME HERE IS PROHIBITED.

UNLESS OTHERWISE SPECIFIED:	DRAWN	PG	DATE
DIMENSIONS ARE IN INCHES	CHECKED		4/24/12
TOLERANCES:	ENG APPR.		
FRACTIONALS	MFG APPR.		
ANGULAR MATCHES			
TWO PLACE DECIMAL ±			
THREE PLACE DECIMAL ±			
INTERPRET GEOMETRIC TOLERANCING PER:	G.A.		
MATERIAL:	COMMENTS:		
FINISH:			
APPLICATION:			
USD ON			
DO NOT SCALE DRAWING			

TITLE:
TOP CLAMP BACK

SIZE DWG. NO.
C M121-010

REV
1

SCALE: 2:1 WEIGHT: **SHEET 1 OF 1**

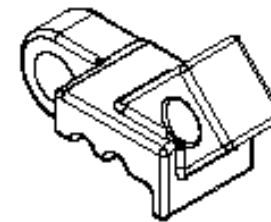
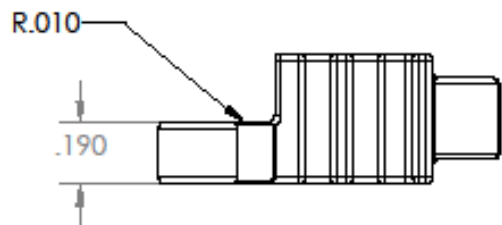
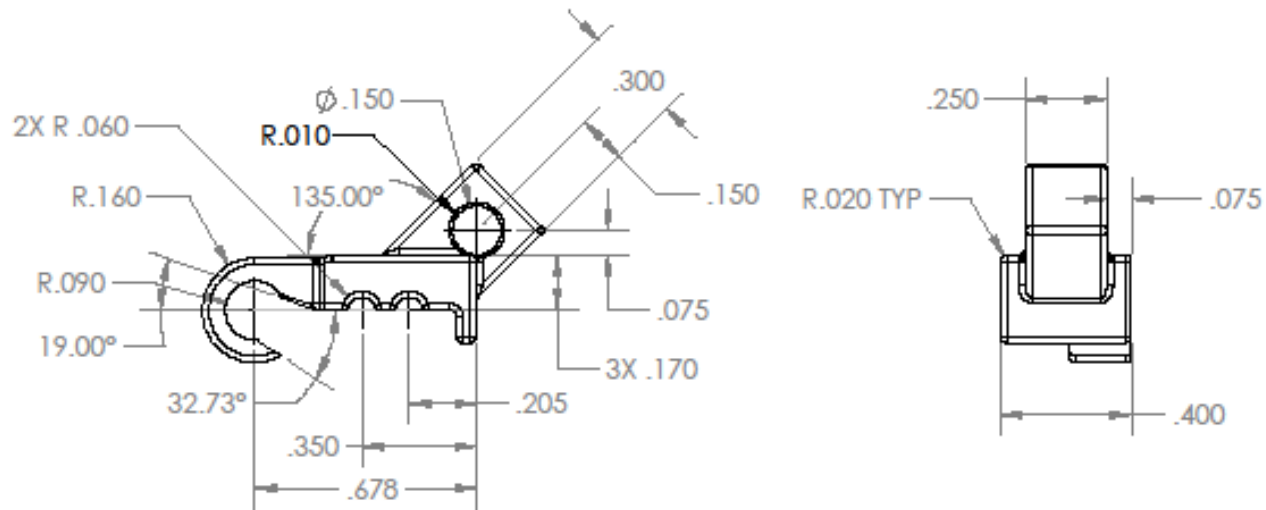

PROPRIETARY AND CONFIDENTIAL
 THE INFORMATION CONTAINED IN THIS DRAWING IS THE SOLE PROPERTY OF QNSER COMPANY NAME HERE. ANY REPRODUCTION IN PART OR AS A WHOLE WITHOUT THE WRITTEN PERMISSION OF QNSER COMPANY NAME HERE IS PROHIBITED.

		UNLESS OTHERWISE SPECIFIED:		NAME	DATE	TITLE: TOP SLIDER QR	
		DIMENSIONS ARE IN INCHES		DRAWN	PG		4/24/12
		TOLERANCES: FRACTIONAL: ±		CHECKED			
		ANGULAR: MACH ±	BEND ±	ENG APPR.			
		TWO PLACE DECIMAL ±	THREE PLACE DECIMAL ±	MFG APPR.			
		INTERPRET GEOMETRIC TOLERANCING PER:		Q.A.			
		MATERIAL:		COMMENTS:			
		FRESH				SIZE DWG. NO. REV	
	NEXT ASSY	USED ON				A M121-011 1	
	APPLICATION	DO NOT SCALE DRAWING				SCALE: 2:1 WEIGHT: SHEET 1 OF 1	

5

4

3

2

1

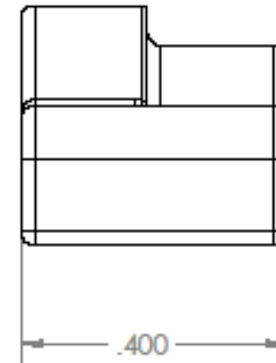
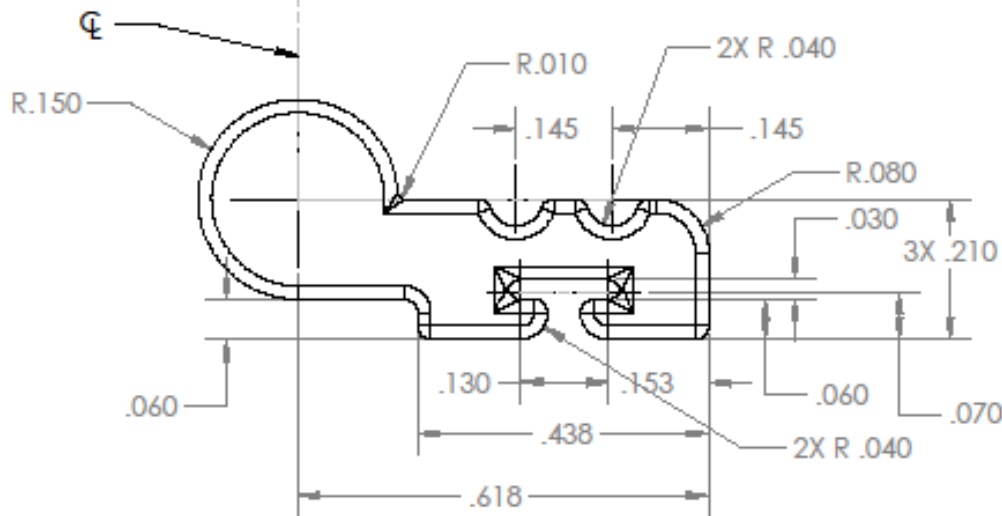
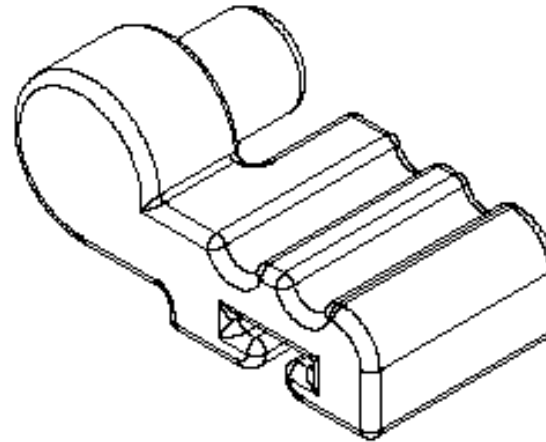
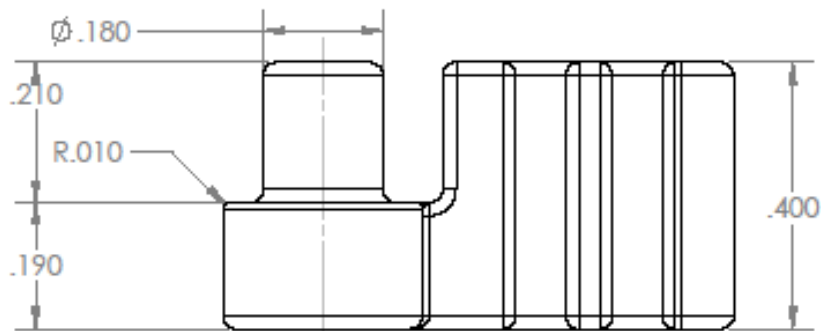

PROPRIETARY AND CONFIDENTIAL
 THE INFORMATION CONTAINED IN THIS DRAWING IS THE SOLE PROPERTY OF <INSERT COMPANY NAME HERE>. ANY REPRODUCTION IN PART OR AS A WHOLE WITHOUT THE WRITTEN PERMISSION OF <INSERT COMPANY NAME HERE> IS PROHIBITED.

		UNLESS OTHERWISE SPECIFIED:		NAME	DATE	TITLE: BOTTOM SLIDER QR	
		DIMENSIONS ARE IN INCHES		DRAWN	PG		4/24/12
		TOLERANCES:		CHECKED			
		FRACTIONAL ±		ENG APPR.			
		ANGULAR: MACH ± BEND ±		MFG APPR.			
		TWO PLACE DECIMAL ±		Q.A.			
		THREE PLACE DECIMAL ±		COMMENTS:			
		INTERPRET GEOMETRIC TOLERANCING PER:					
		MATERIAL:					
		FINISH:					
NEXT ASSY	USED ON					SIZE DWG. NO. REV	
APPLICATION		DO NOT SCALE DRAWING				A M121-012 1	
				SCALE: 4:1	WEIGHT:	SHEET 1 OF 1	

5

4

3

2

1

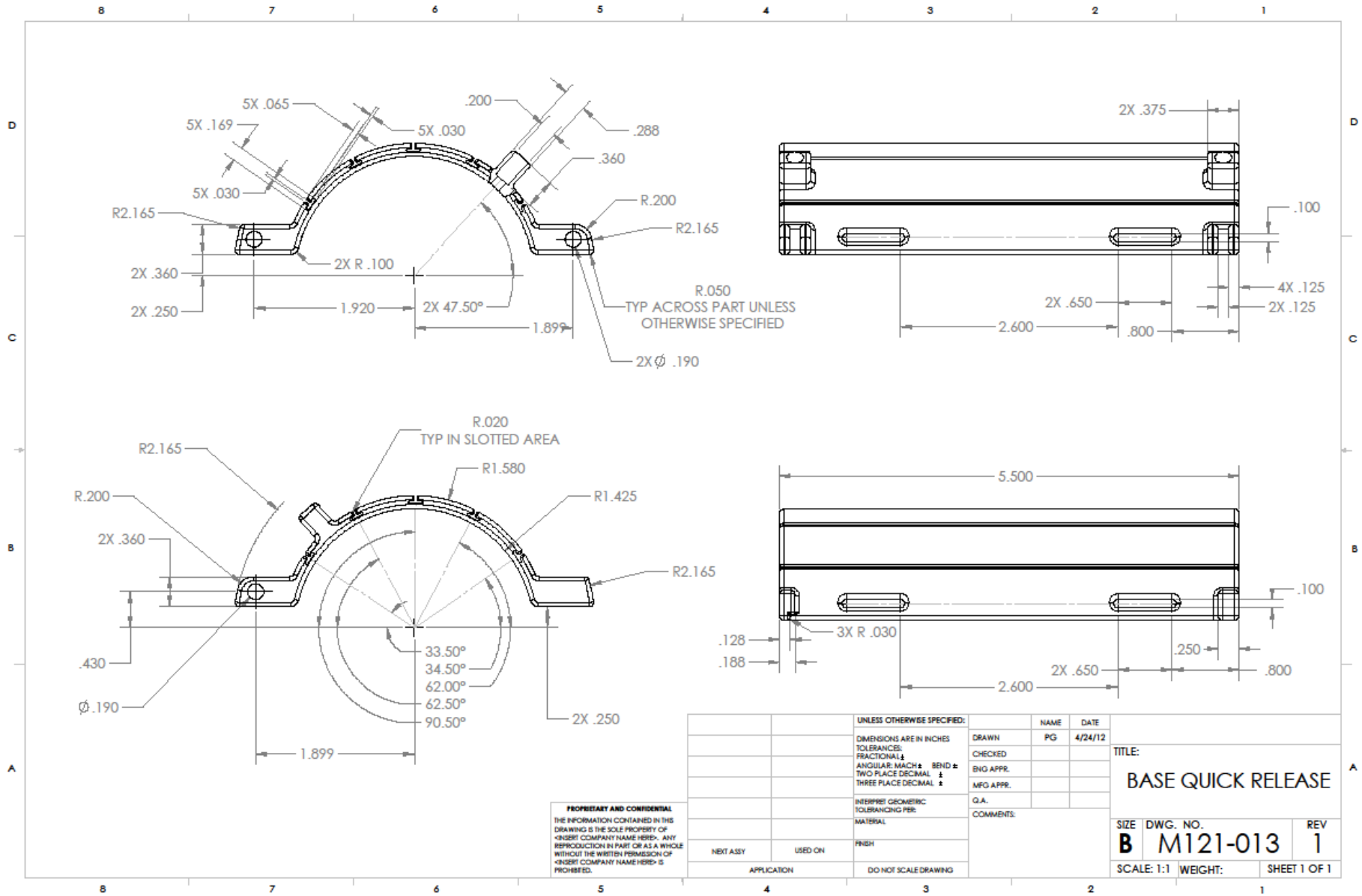

PROPRIETARY AND CONFIDENTIAL
 THE INFORMATION CONTAINED IN THIS DRAWING IS THE SOLE PROPERTY OF CENSBIE COMPANY NAME HERE. ANY REPRODUCTION IN PART OR AS A WHOLE WITHOUT THE WRITTEN PERMISSION OF CENSBIE COMPANY NAME HERE IS PROHIBITED.

UNLESS OTHERWISE SPECIFIED:		NAME	DATE
DIMENSIONS ARE IN INCHES		DRAWN	PG 4/24/12
TOLERANCES:		CHECKED	
FRACTIONAL ±		ENG APPR.	
ANGULAR: MACH ± BEND ±		MFG APPR.	
TWO PLACE DECIMAL ±		Q.A.	
THREE PLACE DECIMAL ±		COMMENTS:	
INTERPRET GEOMETRIC TOLERANCING PER:			
MATERIAL:			
FINISH:			
NEXT ASSY	USED ON		
APPLICATION	DO NOT SCALE DRAWING		

TITLE:
BASE QUICK RELEASE

SIZE DWG. NO. REV
B M121-013 1

SCALE: 1:1 WEIGHT: SHEET 1 OF 1

Appendix G: Code

```
#include "msp430fr5739.h" //MSP430FR5739 general Library
#include <stdio.h>
#include <stdlib.h>
#include <in430.h> //MSP Library

int open = 9; //The duty cycle that corresponds to the opening of the hand is 0.9ms
int middle = 15; //The duty cycle that corresponds to the middle position of the hand is 1.5ms
int fist = 21; //The duty cycle that corresponds to the close position of the hand is 2.1 ms
int pinkycount = 0; //Counting variable for the duty cycle of the pinky
int ringcount = 0; //Counting variable for the duty cycle for the ring finger
int middlecount = 0; //Counting variable for the duty cycle for the middle finger
int pointcount = 0; //Counting variable for the duty cycle for the index finger
int thumbcount = 0; //Counting variable for the duty cycle for the thumb
int pinkydc = 0; //Variable for the duty cycle of the pinky finger
int ringdc = 0; //Variable for the duty cycle of the index finger
int middledc = 0; //Variable for the duty cycle of the middle finger
int pointdc = 0; //Variable for the duty cycle of the pointer finger
int thumbdc = 0; //Variable for the duty cycle of the thumb

void move_finger(int finger, int position);
void move_hand(int position);
void swDelay(unsigned int max_cnt);

void main(void) {
    int flex_raw[5]; //Array to hold current 3 points of flexor EMG data
    int extend_raw[5]; //Array to hold current 3 points of extensor EMG data
    int EMG_count = 0; //counts how many emg readings have been made
    int open = 0;
    int flex_yes = 0;
    int extend_yes = 0;

    WDTCTL = WDTPW + WDTHOLD; //Stop WDT

    PMMCTL0 = 0xA500; //Unlock Register
    PJSEL0 |= BIT4 + BIT5; //Configure BCS, XT1 Setup

    CSCTL0_H = 0xA5; //Unlock register
    CSCTL1 |= 0x0006; //DCO = 8MHz
    CSCTL2 = SELA_3 + SELS_3 + SELM_3; //ACLK = DCO; SMCLK = DCO; MCLK = DCO
    CSCTL3 = DIVA_0 + DIVS_0 + DIVM_0; //ACLK = 8MHz; SMCLK = 8MHz; MCLK = 8MHz

    ADC10CTL0 &= ~ADC10ENC; //Ensure ENC is clear
    ADC10CTL0 = ADC10ON + ADC10SHT_0; //4 CLK Cycles
    ADC10CTL1 = ADC10SHS_0 + ADC10SHP + ADC10CONSEQ_0 + ADC10SSEL_2; //MCLK used, no divider,
single chan, single conver
    ADC10CTL2 = ADC10RES + ADC10SR; //no divider, 10 bit resolution, unsigned, 50kps
    ADC10MCTL0 = ADC10SREF_4 + ADC10INCH_12; //Channel A12, pin 3.0

    UCA1CTLW0 |= 0x0001;
    UCA1CTLW0 = 0xA941; //Clock polarity high, MSB first, Master, 3 pin, Sync mode, ACLK
    UCA1CTLW0 &= 0xFFFE;

    TA1CTL0 = CCIE; //Interrupts enabled
    TA1CCR0 = 800; //Count to 800
    TA1CTL = 0x0110; //TASSEL_1+ MC_1 + TACLR+ID_0;
    TA1EX0 |= 0x0000;
    __bis_SR_register(LPM3_bits + GIE);

    P1SEL0 &= 0x07; //pins 3, 4, 5, 6, 7 as I/O
    P1SEL1 &= 0x07;
    P2SEL0 &= 0x03; //pins 2, 3, 7 as I/O
    P2SEL1 &= 0x73; //pins 4, 5, 6 as SPI
    P2SEL1 |= 0x70;
    P3SEL0 &= 0x0F; //pins 4, 5, 6, 7 as I/O
    P3SEL0 |= 0x07; //pins 0, 1, 2 as ADC
    P3SEL1 &= 0x08;
    P4SEL0 &= 0xFC; //pins 0, 1 as I/O
    P4SEL1 &= 0xFC;
```

```

P1DIR &= 0x07; //pins 3, 5, 6, 7 as input
P2DIR &= 0xB7; //pins 6, 3 as input
P2DIR |= 0xB4; //pins 7, 5, 4, 2 as output
P3DIR &= 0xF8; //pins 0, 1, 2 as input
P3DIR |= 0xF0; //pins 7, 6, 5, 4 as output
P4DIR |= 0x03; //pins 0, 1 as output
P1OUT = 0;
P2OUT = 0;
P3OUT = 0;
P4OUT = 0;

while (1){
/*****Switch Mode*****/
  if((P1IN&0x08)==0x08){
    if((P2IN&0x08)==0x08){ //if toggle is to the right close hand
      move_hand(fist);
      open = 0;
    }
    else if((P1IN&0x10)==0x10){ //if toggle is to the left open hand
      move_hand(open);
      open = 1;
    }
    else{ //if toggle is centered put hand in initialize position
      move_hand(middle);
      open = 1;
    }
  }
/*****EMG Mode*****/
  else if((P1IN&0x40)==0x40){
    ADC10CTL0 &= ~ADC10ENC;
    ADC10MCTL0 = ADC10INCH_12;
    ADC10CTL0 |= 0x0003;
    while(ADC10CTL1 & BUSY){
    }
    flex_raw[0] = flex_raw[1];
    flex_raw[1] = flex_raw[2];
    flex_raw[2] = flex_raw[3];
    flex_raw[3] = flex_raw[4];
    flex_raw[4] = ADC10MEM0&0x03FF;

    ADC10CTL0 &= ~ADC10ENC;
    ADC10MCTL0 = ADC10INCH_13;
    ADC10CTL0 |= 0x0003;
    while(ADC10CTL1 & BUSY){
    }
    extend_raw[0] = extend_raw[1];
    extend_raw[1] = extend_raw[2];
    extend_raw[2] = extend_raw[3];
    extend_raw[3] = extend_raw[4];
    extend_raw[4] = ADC10MEM0&0x03FF;
    EMG_count ++;

    if(EMG_count >=4){
      flex_yes = 0;
      extend_yes = 0;
      for(int i = 0; i < 5; i++){
        if((open == 1)&&(flex_raw[i]<450))
          flex_yes++;
        else if((open == 0)&&(extend_raw[i]<450))
          extend_yes++;
      }
      if(flex_yes > 2)
        move_hand(fist);
      else if(extend_yes > 2)
        move_hand(open);
    }
  }
/*****Program Mode*****/
  else if((P1IN&0x80)==0x80){
    move_hand(fist);
    move_hand(open);
  }
}

```

```

        move_finger(1,fist); //close pinky
        move_finger(1,open); //open pinky
        move_finger(2,fist); //close ring
        move_finger(2,open); //open ring
        move_finger(3,fist); //close middle
        move_finger(3,open); //open middle
        move_finger(4,fist); //close index
        move_finger(4,open); //open index
        move_finger(5,fist); //close thumb
        move_finger(5,open); //open thumb
    }
}

//Timer A0 interrupt service routine
#pragma vector=TIMER1_A0_VECTOR
__interrupt void TIMER1_A0_ISR(void){
    if(pinkydc == 0)
        P2OUT &= 0xFB; //pinky finger holds current position
    else{
        if(pinkycount < (29-pinkydc)) //pinky finger goes to new position
            pinkycount++;
        else{
            if((P2OUT&0x04) == 0x00)
                P2OUT = 0x04;
            else
                P2OUT &= 0xFB;
            pinkycount = 0;
            pinkydc = 30-pinkydc;
        }
    }
    if(ringdc == 0)
        P3OUT &= 0xEF; //ring finger holds current position
    else{
        if(ringcount < (29-ringdc)) //ring finger goes to new position
            ringcount++;
        else{
            if((P3OUT&0x10) == 0x00)
                P3OUT |= 0x10;
            else
                P3OUT &= 0xEF;
            ringcount = 0;
            ringdc = 30-ringdc;
        }
    }
    if(middledc == 0)
        P3OUT &= 0xDF; //middle finger holds current position
    else{
        if(middlecount < (29-middledc)) //middle finger goes to new position
            middlecount++;
        else{
            if((P3OUT&0x20) == 0x00)
                P3OUT |= 0x20;
            else
                P3OUT &= 0xDF;
            middlecount = 0;
            middledc = 30-middledc;
        }
    }
    if(pointdc == 0)
        P3OUT &= 0xBF; //pointer finger holds current position
    else{
        if(pointcount < (29-pointdc)) //pointer finger goes to new position
            pointcount++;
        else{
            if((P3OUT&0x40) == 0x00)
                P3OUT |= 0x40;
            else
                P3OUT &= 0xBF;
            pointcount = 0;
            pointdc = 30-pointdc;
        }
    }
}

```

```

    }
}
if(thumbdc == 0)
    P3OUT &= 0x7F; //thumb holds current position
else{
    if(thumbcount < (29-thumbdc)) //thumb goes to new position
        thumbcount++;
    else{
        if((P3OUT&0x80) == 0x00)
            P3OUT |= 0x80;
        else
            P3OUT &= 0x7F;
            thumbcount = 0;
            thumbdc = 30-thumbdc;
        }
    }
}
__bic_SR_register_on_exit(LPM3_bits); //Exit Low Power Mode
}

/*****Additional Functions*****/

/*The move_finger function allows the user to select a finger and position and
the coresoponding finger will move to the given position. This function also
for finger coupling ie. when the middle finger moves both the ring and index finger
wil move as well
*/
void move_finger(int finger, int position){
    swDelay(100);
    switch(finger){
    case 1: // pinky
        P2OUT &= 0xFB; //pinky reset
        P3OUT &= 0xEF; //ring reset
        pinkydc = position;
        ringdc = ((position-9)/2)+9; //pinky ring finger coupling relation
        break;
    case 2: // ring
        P3OUT &= 0xEF; //ring reset
        P2OUT &= 0xFB; //pinky reset
        P3OUT &= 0xDF; //middle reset
        ringdc = position;
        pinkydc = ((position-9)/2)+9; //ring pinky coupling relation
        middledc = ((position-9)/2)+9; //ring middle coupling relation
        break;
    case 3: //middle
        P3OUT &= 0xDF; //middle reset
        P3OUT &= 0xEF; //ring reset
        P3OUT &= 0xBF; //pointer reset
        middledc = position;
        ringdc = ((position-9)/2)+9; //middle ring coupling relation
        pointdc = ((position-9)/2)+9; //middle pointer coupling relation
        break;
    case 4: // pointer
        P3OUT &= 0xBF; //pointer reset
        P3OUT &= 0xDF; //middle reset
        pointdc = position;
        middledc = ((position-9)/2)+9; //pointer middle coupling relation
        break;
    case 5: //thumb
        P3OUT &= 0x7F; //thumb reset
        thumbdc = position;
        break;
    }
}

/* the SwDelay function is a pause function that makes the system wait a given amount of time */
void swDelay(unsigned int max_cnt){
    unsigned int cnt1=0, cnt2;
    while (cnt1 < max_cnt){
        cnt2 = 0;
        while (cnt2 < 32768)
            cnt2++;
    }
}

```



```
        cnt1++;
    }
}

/* the move_hand function moves the entire hand to whatever position is given
as an input*/
void move_hand(int position){
    swDelay(100);
    P2OUT &= 0xFB; //pinky reset
    pinkydc = position;
    P3OUT &= 0xEF; //ring reset
    ringdc = position;
    P3OUT &= 0xDF; //middle reset
    middledc = position;
    P3OUT &= 0xBF; //pointer reset
    pointdc = position;
    P3OUT &= 0x7F; //thumb reset
    thumbdc = position;
}
```