

January 2006

Laser Audio Surveillance Device

Vincent T. Amendolare
Worcester Polytechnic Institute

Wade M. Sarraf
Worcester Polytechnic Institute

Follow this and additional works at: <https://digitalcommons.wpi.edu/mqp-all>

Repository Citation

Amendolare, V. T., & Sarraf, W. M. (2006). *Laser Audio Surveillance Device*. Retrieved from <https://digitalcommons.wpi.edu/mqp-all/2900>

This Unrestricted is brought to you for free and open access by the Major Qualifying Projects at Digital WPI. It has been accepted for inclusion in Major Qualifying Projects (All Years) by an authorized administrator of Digital WPI. For more information, please contact digitalwpi@wpi.edu.

Project Number: BYK-BUG2

Laser Audio Surveillance Device

A Major Qualifying Project Report
submitted to the Faculty of
WORCESTER POLYTECHNIC INSTITUTE
in partial fulfillment of the requirements for the
Degree of Bachelor of Science
by

Vincent Amendolare

Wade Sarraf

on

December 19, 2005

Approved:
Professor Brian King, Advisor

Abstract

The purpose of this project was to create an eavesdropping device that operated by pointing a laser beam at a window and reconstructing the audio of a conversation on the other side of the window. The project sought to improve on a previous year's project which was sensitive to the angle between the laser beam and the window surface normal. This system was implemented using a laser, arrangement of lenses, and circuitry including a digital signal processor.

Table of Contents

Abstract.....	ii
Table of Contents.....	iii
Table of Figures.....	v
Executive Summary.....	vii
1 Introduction.....	1
2 Project Objectives.....	2
2.1 Project from Previous Year.....	2
2.2 Project Goals and Constraints.....	2
3 Background Information/Theory.....	4
3.1 Acoustic Waves and Window Vibration.....	4
3.2 Optical Theory.....	5
3.2.1 Collimation Concepts.....	5
3.2.2 Transmission and Reflection Concepts.....	6
3.2.3 Detection Concepts.....	10
3.3 Lasers.....	11
3.4 Sensing methods.....	13
3.4.1 Correlation.....	15
3.4.2 Spectrometry and Doppler Effect.....	16
3.4.3 Time of Flight.....	17
4 Methodology.....	18
4.1 Investigation of Possible Implementation Methods.....	18
4.1.1 Time of Flight.....	18
4.1.2 Doppler Shift.....	19
4.1.3 Amplitude Modulation with Correlation.....	19
4.1.4 Interferometry.....	20
4.1.5 Proof of Concept.....	20
4.2 Refinement of Design.....	21
4.2.1 Laser Diode Driver.....	21
4.2.2 Optics.....	22
4.2.3 Detection.....	22
4.2.4 Early Signal Processing.....	23
4.2.5 Correlation.....	24
4.2.6 Digital Signal Processing.....	25
4.2.7 Audio Driver.....	27
4.2.8 System Integration.....	27
4.3 Summary.....	27
Implementation.....	28
4.4 General Functionality.....	28
4.5 Laser Diode Driver.....	29
4.6 Optics.....	31
4.7 Photo-detector Circuit.....	34
4.8 Early Signal Processing.....	36
4.9 Correlation.....	39

4.10	Digital Signal Processing.....	43
4.10.1	Setup	43
4.10.2	The Program.....	45
4.10.3	Configuration	46
4.10.4	Main	47
4.10.5	Square Wave	47
4.10.6	ADC interrupt	48
4.10.7	PWM Frequency and PWM Duty Cycle Interrupts.....	50
4.11	Output Stage.....	52
4.12	System Integration	52
5	Performance	54
5.1	Laser Diode Driver	54
5.2	Detection and Early Signal Processing.....	55
5.3	Correlation	61
5.4	Digital Signal Processing.....	62
5.4.1	Clock.....	63
5.4.2	Reset Signal	64
5.4.3	Pulse Width Modulation	65
5.4.4	Reconstruction Filter.....	66
5.5	Total System Performance.....	68
6	Conclusions and Recommendations	71
6.1	General Conclusions	71
6.2	Recommendations for Specific Modules.....	72
6.3	General Recommendations	74
7	Appendices.....	76
7.1	Components List.....	76
7.2	Full Circuit Schematic	77
7.3	dsPIC Code	78
7.4	System Pictures.....	84
8	References.....	89

Table of Figures

Figure 3-1 Divergence Angle.....	5
Figure 3-2 Convex Lens.....	6
Figure 3-3 LED Collimation.....	6
Figure 3-4 Law of Reflection.....	7
Figure 3-5 Specular and Diffuse Reflection.....	8
Figure 3-6 Angular Distribution of Light.....	9
Figure 3-7 Acceptance Angle.....	11
Figure 3-8 Output Power vs. Forward Current of Laser Diode.....	12
Figure 3-9 Interferometer.....	14
Figure 3-10 Fringe Pattern.....	15
Figure 3-11 Correlation Graph.....	16
Figure 0-1 System Block Diagram.....	28
Figure 0-2 Laser Diode Driver Functionality.....	29
Figure 0-3 Laser Diode Driver Circuit.....	30
Figure 0-4 Optics Functionality.....	32
Figure 0-5 Collimation Optics.....	32
Figure 0-6 Laser and Window Configuration (Side View).....	33
Figure 0-7 Laser and Detector Setup (Top View).....	33
Figure 0-8 System Setup.....	34
Figure 0-9 Detector Functionality.....	34
Figure 0-10 Photo-Detector Circuit.....	35
Figure 0-11 Theoretical Output of Detection Stage.....	36
Figure 0-12 Early Signal Processing Functionality.....	36
Figure 0-13 High Pass Filter Circuit.....	37
Figure 0-14 Theoretical High Pass Filter Output.....	37
Figure 0-15 Gain Stage.....	38
Figure 0-16 Theoretical Output of Gain Stage.....	38
Figure 0-17 Clamper Circuit.....	39
Figure 0-18 Theoretical Output of the Clamper Circuit.....	39
Figure 0-19 Multiplier Functionality.....	40
Figure 0-20 Analog Multiplier.....	40
Figure 0-21 Theoretical Output of Multiplier.....	40
Figure 0-22 Integrator Functionality.....	41
Figure 0-23 Integrator with Reset Switch.....	41
Figure 0-24 Theoretical Output of Integrator.....	42
Figure 0-25 Digital Signal Processing Functionality.....	43
Figure 0-26 dsPIC Pinout.....	44
Figure 0-27 dsPIC Circuit Diagram.....	44
Figure 0-28 Program Functionality.....	46
Figure 0-29 Theoretical Output of Vpwm.....	51
Figure 0-30 Reconstruction Filter.....	52
Figure 0-31 Full Circuit Schematic.....	53
Figure 5-1 Voltage across Laser Diode.....	55
Figure 5-2 Detector Stage output Voltage (No Capacitor).....	56

Figure 5-3 Detector Stage output Voltage (With Capacitor)	57
Figure 5-4 High Pass Filter Stage Output	58
Figure 5-5 Gain Stage Output	59
Figure 5-6 Output of Clamper Stage.....	60
Figure 5-7 Multiplier Output	61
Figure 5-8 Integrator Output.....	62
Figure 5-9 Inverted and Non-Inverted Clock Outputs.....	63
Figure 5-10 Clock Outputs with Interrupt	64
Figure 5-11 Vreset Waveform	65
Figure 5-12 Output of PWM with Sinusoidal Input	66
Figure 5-13 PWM Output and Reconstructed Signal	67
Figure 5-14 Input Waveform and Reconstructed Signal	68
Figure 5-15 Total System Setup	69
Figure 5-16 Reconstructed Audio Signal.....	70
Figure 7-1 Full Circuit Schematic.....	77
Figure 7-2 Circuit Picture	84
Figure 7-3 Circuit and Detector Assembly Picture.....	84
Figure 7-4 Laser Audio Surveillance Device.....	85
Figure 7-5 Device and Window.....	85
Figure 7-6 Laser Diode Mount (with Collimation Lenses)	86
Figure 7-7 Window and Subwoofer.....	86
Figure 7-8 Fresnel Lens	87
Figure 7-9 Detector Assembly and Additional Lens	87
Figure 7-10 Entire System	88

Executive Summary

The purpose of this project was to design a remote audio surveillance device. This project was a follow-up to a Major Qualifying Project (MQP) completed the previous academic year, which created a remote audio surveillance device that used a laser beam incident on a window to listen to a conversation. Their device was successful in achieving their goal, but not without significant limitations. These limitations included that fact that their device needed to be very carefully set up knowing precisely where the laser beam and the laser beam reflected from the window. Their device was also extremely sensitive to external vibrations. These limitations are not very desirable in a situation where one desires to eavesdrop on a conversation. Their device required the measurement of the reflected laser beam, which essentially meant that they needed to point the laser perpendicular to the window so that the reflected beam would come straight back. This would not be practical in many situations.

We strove to design a device that used the same principle of shining a laser beam on a window to eavesdrop on a conversation, but to overcome the limitations that hindered the previous project. Our main focus was to create a device that could simply be pointed at a window, without any concern for the location of the reflected beam, and still listen to the conversation within the window

The basic physical principle exploited in the previous year's project was that when an acoustic wave is incident on a window it causes the window to bow in and out slightly. This causes the angle of the surface of the window to change slightly, changing the angle of reflection of any reflected light. Since the reflected light from a laser on a window is not uniform, the amplitude of light measured at any given point will change if the angle of the window changes. The previous year's project used two light detectors to measure the deviation in position of a reflected laser beam. In order to make any measurements without knowing the position of the reflected beam we needed to measure light that was being reflected back towards the device.

When a laser is incident on a window, most of the light will be reflected back in the form of a beam, however some of the light is scattered back in all directions, known as backscatter. If our device was to perform the function we intended it to, it needed to be able to detect these very small levels of light and extract the audio information from it.

Thus the main focus of this project was to design a device that could measure extremely small amounts of light, and also be able to discard any light information from any source but the laser. In order to perform this task we needed to create a system that used various techniques to work with the very small signal we were able to detect. We used a technique known as “Walsh Function Correlation” to be able to extract the small signal from the noise present in the circuit. We also used a digital signal microprocessor to provide us with digital signals needed as well as process our audio signal so it could be then converted back into audio.

Unfortunately, due to time constraints we were unable to bring our system to the level of functionality desired. Ultimately we were not able to extract audio information from the small levels of light we could detect. We were able to detect relatively small amounts of light with the system; we could tell whether or not backscatter was present. We were able to prove the functionality of our system by using the actual reflected laser beam. Our goal was to create a device that did not require the use of the reflected laser beam, however we used it to test the system and indeed were able to detect audio with this much stronger signal.

Although we did not meet the objectives of the project that we set for ourselves, we did make major accomplishments towards reaching this goal. Based upon the results of our project, we conclude that our goals are possible to attain and with further time invested into another design phase, we believe a successful device could be implemented. We therefore recommend to our advisor that he consider assigning a future MQP group the task of using the research and design work we have put towards reaching this goal.

1 Introduction

The purpose of this project was to create a remote audio surveillance device. Such a device would allow the user to listen to a remote conversation without ever having to infiltrate the premises. This project was the second design phase in building such a device. During the previous academic year an initial attempt to build such a device was completed by another project group. Our objective was to improve on their design.

Acoustic waves created by the human voice cause a nearby window to vibrate on a very small scale. By shining a laser beam on a window and analyzing the reflected beam, it is possible to retrieve the audio information from a conversation near the window. The vibration of the window will actually cause the window to bow in and out slightly, changing the angle at each point in the window along with the audio signal. If a laser beam was incident on this window, the angle that the reflected beam would come back at would vary with this angular change. By determining how much the reflected laser beam was displaced, the audio signal could then be recreated. The previous project team implemented such a device successfully.

Their device had significant limitations however. Their testing showed that their device was extremely sensitive to external vibrations. Also their device needed to be carefully set up with a photo-detector assembly placed precisely where the reflected beam was. This generally meant that unless one could place the detector far away from the laser itself, then the laser beam had to be approximately perpendicular to the window, limiting the possible locations from which to plant the device. These were the main two limitations of the previous team's design, and were the areas in which we tried to improve the device.

Our objective was to use backscatter, the small amount of light reflected diffusely from the window, to be able to recover the audio signal from a wider range of angles, and without needing to carefully place a detector assembly. We also sought to make our device less sensitive to external vibrations. In order to be able to detect the very small amount of light reflected as backscatter, we needed to create a system that was extremely sensitive to light, and also could differentiate the component of light that was being reflected from the window as opposed to the ambient light. In this report we will explain the avenues we explored to create such a device, and the degree to which it was a success.

2 Project Objectives

Our project is the second phase of design of a laser audio surveillance device. We based our goals for this project on the success and limitations of the previous instance of this project. The scope of our project was also limited by other parameters such as time and resources. In this section we will explain how we formulated our project objectives based upon these factors.

2.1 Project from Previous Year

In the 2004-2005 academic year, a Major Qualifying Project was completed to build a laser audio surveillance device to eavesdrop on conversations by pointing a laser beam at a window. As mentioned, acoustic waves cause the angle of a window pane to change with an incident acoustic wave.

The students who completed this project last year utilized this principle. They pointed a laser beam at a window and carefully placed their detector assembly to intercept the reflected beam. This detector assembly had two photo-detectors placed some distance apart with the reflected beam in the between them when the window was at rest. When the window began to vibrate, the beam's position moved and became closer to one detector. The relative intensities that each detector observed made it possible to determine the beams position, and thus the angle at which it was being reflected.

This method proved to be successful for observing conversations by pointing a laser beam at a window. The main limitation to this approach however, was the extreme sensitivity of the placement of the detector assembly. The detector assembly needed to be carefully placed making the device more difficult and time consuming to set up. Also, unless one desired to place the detector assembly far away from the laser, then the laser beam needed to be approximately perpendicular to the window, limiting the possibilities of placement points for the device. In addition, the device was also extremely sensitive to any external vibrations that would vibrate the laser or detector assembly, causing noise in the detected audio signal. [1]

2.2 Project Goals and Constraints

The primary goal of this project was to create a laser audio surveillance device that improved upon the previous year's design in its main areas of limitation: ease of

setup and sensitivity to external vibration. We sought to create a device which would work without having to carefully set up a detector in a reflected laser beam, but rather a device which would work simply by pointing a laser at a window, with no dependence on the location of the reflected beam. We realized that it may not be possible to use our device at all angles of incidence with the window, but we sought to achieve the widest range of angles possible. This device needed to be used remotely and therefore function at significant distances from the window.

This project was completed in 14-weeks, time was a major constraint to what was possible for us to accomplish. Also we were limited to a \$250 budget. We were provided an optics laboratory with both electrical and optical equipment necessary for the project.

Further practical constraints existed for the device itself. We sought to create this device using a low power laser to avoid any safety concerns. We decided that the device should be portable and therefore run on batteries. We also took into consideration temperature fluctuations so they would not adversely affect the device.

3 Background Information/Theory

In this section we will explain the background information and theory necessary to understand the functionality of our project discussed later in the report. Pertinent topics include: optics, lasers, vibration, and light detection.

3.1 Acoustic Waves and Window Vibration

What humans perceive as sound is acoustic waves traveling through the air. These are pressure waves; the pressure of the air varies as a function of space in a wave pattern and these waves propagate through the air at the speed of sound (340 m/s) [2]. These wave patterns are created by any vibrating objects which cause disturbances in the air pressure, which is an acoustic wave. Humans can hear acoustic waves as sound from approximately 20Hz to 20kHz, while human voices produce sound from about 300Hz to 3400Hz [3].

Acoustic waves are not only caused by objects vibrating but can also cause objects to vibrate. For example, a speaker vibrating can create an acoustic wave while another speaker can be caused to vibrate by this acoustic wave and act as a microphone. This same principle applies to a window. An acoustic wave hitting the window will cause it to vibrate, if only a very small amount. Generally the sides of a window are firmly fixed so most of the vibration occurs towards the center of the window. This causes the window to bow in and out with the vibrations. The window will actually vibrate in several two dimensional mode patterns. At a given point on a window however, vibration will be present from most or all of the vibrating modes, containing all of the audio information.

The fundamental principle about the window's vibration that the detection method utilized was that this bowing action causes the angle of the glass to change slightly. This means that if a light source was incident on the window, the reflected light would change in angle as the window surface changed in angle from the acoustic waves.

3.2 Optical Theory

Laser light is the medium which the previous project team used to obtain audio information from a vibrating window. Electronic circuits ultimately processed the information carried by the laser into a convert it back into sound for an eavesdropper to listen to. Assuming we would use a similar approach, research into the area of optics was necessary. In this section we will present background information on optics relative to the system we designed.

3.2.1 Collimation Concepts

The first stage in the most laser systems is the collimation of the light source. When laser light leaves the source with no optics it radiates out in a predetermined pattern. The angle over which the light will spread after it leaves the sources is defined as the divergence angle. The most common definition of the divergence angle is the half-angle between the center of the beam and the half power point on either side [4].

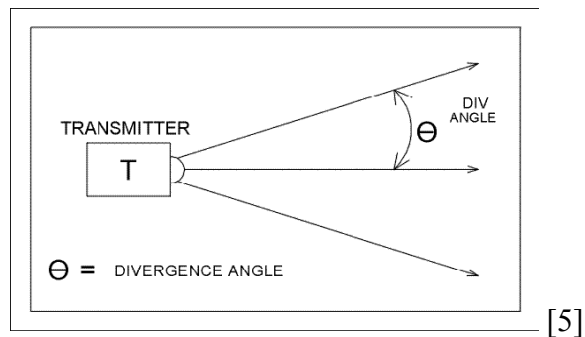
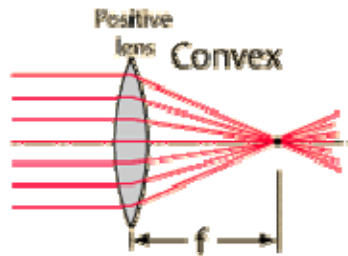

Figure 3-1 Divergence Angle

The goal of collimation is to make the divergence angle zero, in other words the photons of light leaving the collimation lens will all be moving in the same direction and not spread out. In reality perfect collimation can never be achieved due to imperfections of lens alignment and the diffraction of light.

To achieve collimation generally convex lenses are used. The effectiveness of collimation is dependent on the radius, and focal length of the collimation lens as well as the divergence angle of the light source. A convex lens, as shown in the figure below directs the parallel beams coming from the left to a point to the right of the lens. This point is called the focal point, and the distance it is away from the lens is called the focal length of the lens.



[6]

Figure 3-2 Convex Lens

Now consider the effect of light that is being radiated from a source at the focal point of the lens. If you look at the figure above you can see that all the light generated from a source at the focal point is directed in parallel beams moving to the left. The beam has been collimated. Of course this case is ideal, light from a source at the focal length diverges just enough to reach the outer edge of the lens.

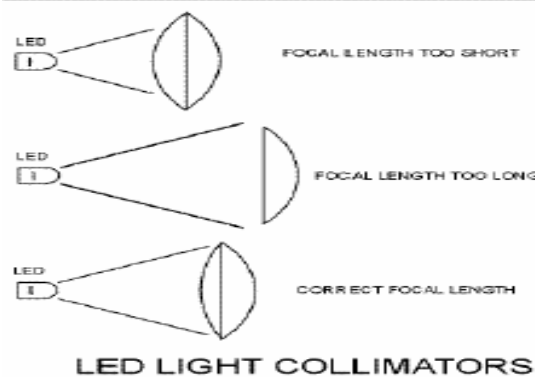

[7]

Figure 3-3 LED Collimation

The figure above illustrates less than ideal scenarios. If the light diverges past the outer edge of the lens you are losing light that could have been collimated. If the light does not reach the outer edge the lens you are using is too large and could be replaced with a smaller cheaper lens. The third example is the correct setup for collimation.

3.2.2 Transmission and Reflection Concepts

The transmission and reflection of light are also important concepts relevant to this project. The main concepts that govern this process are the Fresnel equation, the inverse square law, and the principles of reflection.

When a laser beam is incident on a window some of it will pass through and some will be reflected back. The equation that governs the ratio between the reflected and

passed amounts of the beam is the Fresnel equation. The equation predicts the reflected and passed percentages based on the refractive index of air versus the glass. The approximate estimate for reflection percentage of a laser reflecting off glass is around 4%; the rest passes through the glass.

The fraction of the beam that gets reflected back follows the laws of reflection. The Law of Reflection governs the behavior of light as it bounces off of a reflective surface. The elements of a reflection include an incoming ray of light (the incident ray), the normal line, and the reflected ray. The normal line is drawn perpendicular to the surface at the point of incidence. The law states that the angle of the incident ray with respect to the normal line will equal the angle of the reflected ray with respect to the normal line[8].

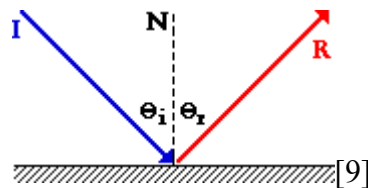

Figure 3-4 Law of Reflection

We cannot assume that a window's surface is perfectly smooth. Under some level of magnification the window will appear to have imperfections. The properties of a surface on the microscopic level determine the behavior of incident light beams. The two extremes of reflection are diffuse and specular reflection [10].

Diffuse reflection is the result of a beam of light hitting a surface that is rough with respect to the light's wavelength. This means that the deviations in the surface are similar in magnitude to the wavelength of the incident light. The reflected light rays all follow the Law of Reflection but because the surface orientation is changing, the light is being reflected back in different directions. The right diagram in the figure below depicts a diffuse reflection.

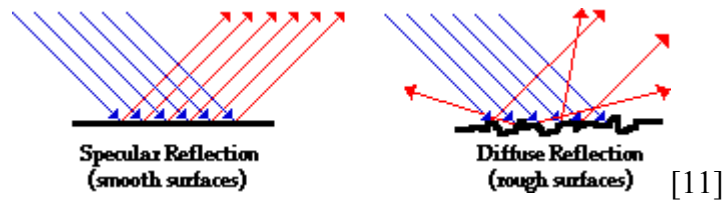

Figure 3-5 Specular and Diffuse Reflection

Specular Reflection is the result of light beam reflecting off a surface that is smooth with respect to the wavelength of the incident light. In the case of light, a mirror or anything else of similar smoothness causes specular reflection. As illustrated in the left diagram of the above figure, all of the incident light is reflected in the same manner because the orientation of the surface remains constant with respect to the beam.

In the case of a laser beam being reflected off of a window, the reflected light will have components of both specular and diffuse reflection. The specular reflection forms the reflected beam, while the diffuse reflection is known as backscatter.

If an observer witnessed a laser beam incident on a window, they would see a faint dot on the window at the spot where the laser hits the window. What they see would be the light that is diffusely reflected from the window at that point, some of which travels in the direction of the witness' eye. This dot on the window is known as the backscatter dot. We conducted an experiment to determine the angular distribution of light reflected off of a window surface. We measured the angular distribution of light with a laser incident on a clean window, scratched window, and an opaque spot on the window (paper).

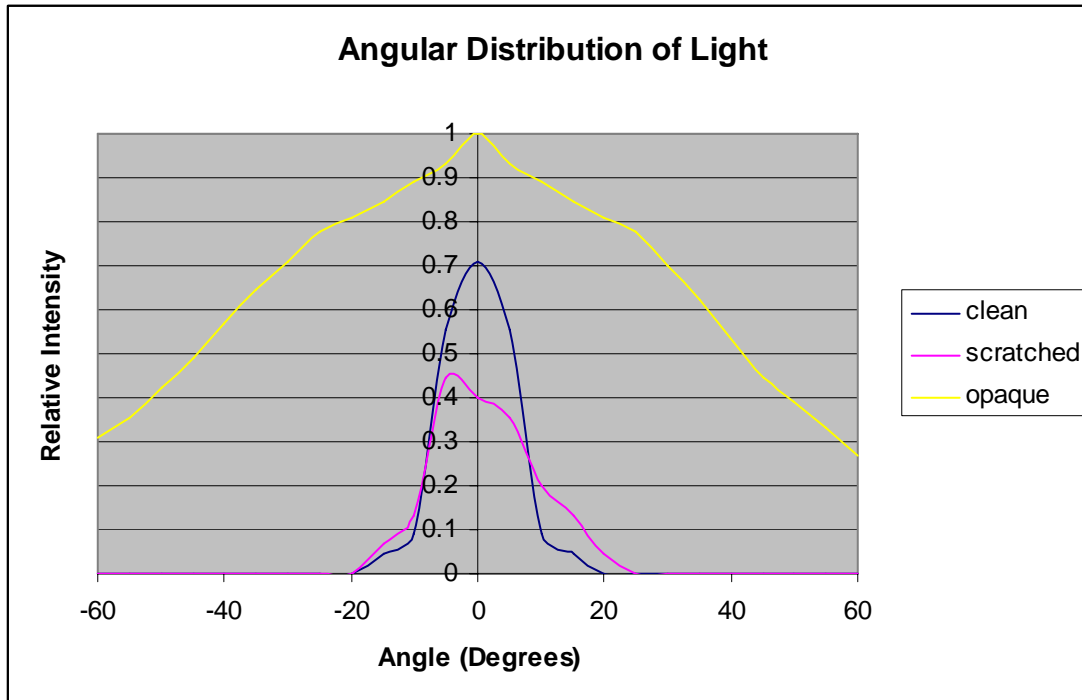

Figure 3-6 Angular Distribution of Light

The above graph shows the trend we observed. For the clean glass, we observed that most of the light was reflected very tightly in the reflected beam, although there was some backscatter measurable at broader angles. The glass being scratched decreased the integrity of the reflected beam. Overall it diffused the reflected beam, scattering more of the light at broader angles. The opaque object stopped the light from being transmitted through the window, so more light was reflected. This reflection was completely diffuse and was therefore spread over all angles. It is important to note that the light was still most intense about zero degrees. We concluded based on this that diffuse reflections do not reflect back equally among all angles, but follow a certain angular distribution pattern.

It is this principle that we sought to exploit in order to retrieve and audio signal from a reflected laser beam, based on the fact that the window angle changes slightly with an incident acoustic wave. It was important that the signal we received was linearly proportional to the original audio signal. It is clear from the above graph that the light intensity is not a linear function of angle. Any curve however, if considered over small enough a portion of its domain, can be approximated as a linear function. Since the

changes in angle the window undergoes are extremely small, we hypothesized that the reflected light intensity would behave as a linear function of the incident acoustic wave.

3.2.3 Detection Concepts

Once the light reflects off the window it immediately has some angular distribution. The rate that this distribution spreads out as function of distance from the source is governed by the Inverse Square Law. In terms of light the Inverse Square Law states that the intensity I , of the light a distance D , away from the source will be the sources intensity times the inverse of the square of the distance, that is $I * D^{-2}$.

As an example let us consider attempting to detect laser light at a distance of about 20 ft from the window. According to the Inverse Square Law the intensity of the light reflected will be 0.0025. If the reflection off the window were completely diffuse and 100% of the beam was reflected then the intensity of light at 20ft would be $\frac{1}{4}$ of a percent. This is the best case scenario, the reality is that the window appears smooth at the wavelength of laser and a good portion of the light is reflected in a specular manner.

It is difficult to determine the exact amount of backscatter but consider the scenario where the window is slightly flawed so 5% of the beam is reflected, and 10% of the reflection is diffuse. That means that the percentage of the main beam that we would be able to detect right at the window would be $\frac{1}{2}$ of a percent. 20ft away from the window the intensity would be 0.00125%.

Integrating the amount of light on a half sphere 20ft away from the window would add up to the original amount reflected light. The optics setup on the detection end of the circuit determines how much of this light the detector will receive. The ratio of the surface area of the detector lens to the surface area of the sphere is the fraction of the total reflected light that the detector can see.

The detection lens must also have an acceptance angle allows it to observe the reflected light.

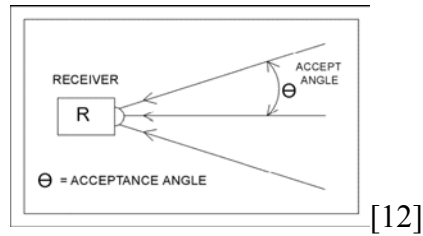

Figure 3-7 Acceptance Angle

The half-angle over which the receivers lens can focus light onto the receiver is defined as the acceptance angle[13]. All light outside of this cone will not be measured by the detector.

3.3 Lasers

A laser is a source of light with several properties which make them unique compared to most sources of light. Lasers are monochromatic, coherent and highly directional. These properties make lasers extremely useful as these properties can be exploited to achieve many useful results.

The fact that a laser is monochromatic means that it only releases light of a single frequency/wavelength. It is more correct to say that lasers produce light that is very tightly centered around one frequency; more so than any other light source. Lasers are available in a broad range of frequencies, from far-infrared through the visible light spectrum to ultraviolet light. The frequency which a laser operates at can fluctuate with temperature and also the injection current. There are various methods employed to counteract these problems in applications where the stability of the frequency is important. [14]

Coherent light is light in which each photon travels in step with the other photons. This results in the light having a specific phase at a given point since each wave front travels in unison. This can be useful when laser light from two paths is superimposed and a wave interference pattern is created. This can be used to tell the difference in distance of the two light paths with a technique called interferometry.

Laser light is emitted with its light traveling in a specific direction. This means that laser light can travel over relatively great distances in a tightly focused beam

compared to other sources of light. This is useful when it is desired to send light to a specific point over a significant distance.

One important technique that can be used with lasers, as well as other light sources, is amplitude modulation. The amplitude of the laser light is changed with time to correspond to a given function. If a detector is then used to detect the laser light, the function can be looked for in the detected signal to determine the contribution from the laser light as opposed to stray ambient light. The other advantage to amplitude modulation is that it moves any information it is carrying from its original bandwidth (for example the audio band) up to around its carrier frequency. This is useful because it may be easier to transmit these higher frequencies, or to isolate the desired information through filtering. Lasers can generally be modulated much faster than other light sources which are another reason they are useful.

There are many different types of lasers. They vary in terms of cost, size, frequency, beam shape, power and are used for a wide range of applications. One of the most common types of laser for low-power inexpensive applications is the laser diode. In order to turn on a laser diode it must be driven with a current. The output power (light level) is a function of the input current as shown below.

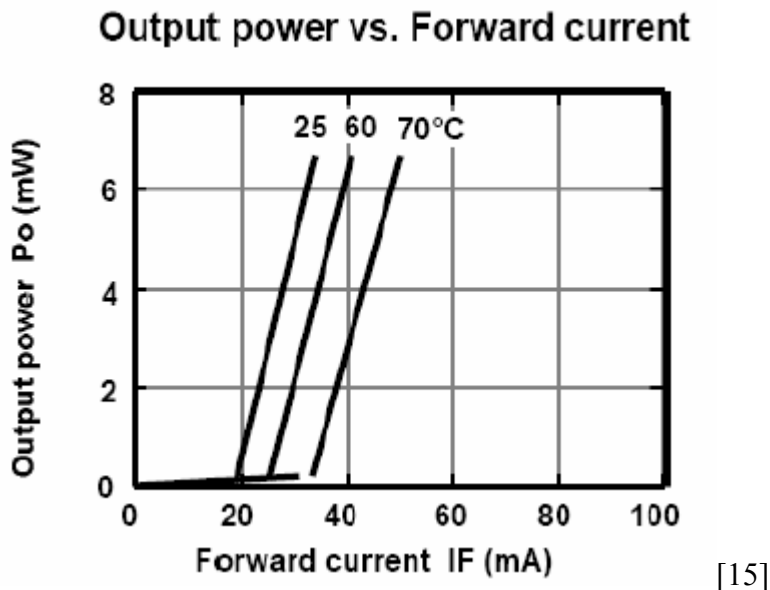

Figure 3-8 Output Power vs. Forward Current of Laser Diode

The output power is approximately linearly proportional to the input current, but only after the threshold current has been exceeded. This is an important fact to consider

when modulating the laser diode. One must be sure that the input current never goes below the threshold value or the laser will turn off, and take a few microseconds to turn back on, which is undesirable. It is also important to note that any fluctuation in the input current may cause an undesired fluctuation in the output power. Temperature may also cause the power curve to be shifted, as seen in the above figure. These problems can be alleviated by control systems that use a photo-detector to ensure that the output power is constant.

The output power level of a laser is a concern due to lasers being a safety hazard. Lasers have been given classifications based on their output power for this reason. A qualitative description of these classes is given below:

Class 1 lasers

Class 1 lasers are considered to be incapable of producing damaging radiation levels, and are therefore exempt from most control measures or other forms of surveillance. Example: laser printers.

Class 2 lasers

Class 2 lasers emit radiation in the visible portion of the spectrum, and protection is normally afforded by the normal human aversion response (blink reflex) to bright radiant sources. They may be hazardous if viewed directly for extended periods of time. Example: laser pointers.

Class 3 lasers

Class 3a lasers are those that normally would not produce injury if viewed only momentarily with the unaided eye. They may present a hazard if viewed using collecting optics, e.g., telescopes, microscopes, or binoculars. Example: HeNe lasers above 1 milliwatt but not exceeding 5 milliwatts radiant power.

Class 3b lasers can cause severe eye injuries if beams are viewed directly or specular reflections are viewed. A Class 3 laser is not normally a fire hazard. Example: visible HeNe lasers above 5 milliwatts but not exceeding 500 milliwatts radiant power.

Class 4 lasers

Class 4 lasers are a hazard to the eye from the direct beam and specular reflections and sometimes even from diffuse reflections. Class 4 lasers can also start fires and can damage skin. [16]

The output power of a laser is important to consider in any laser application.

3.4 Sensing methods

Now that we have discussed these optical principles and the functionality of lasers, we can begin examining methods of light detection. Our specific project goal has never been attempted as far as we know, so we will need to decide what the most logical

method of measuring light is for us. The possible methods we have come up with are adaptations of techniques used to either capture very small signals in general, and/or previously used to measure distance. In this section we will give some background information on Interferometry, Correlation, Spectrometry, and Time of Flight techniques.

For our purposes, interferometry is a method involving the combination of two or more optical measurements, and combining these data to form a greater picture based on the combination of the two sources. [17] This methods works on the principal that waves arriving at the same time will interfere with each other. Constructive interference is when waves arrive in phase with each of other, in which case their amplitudes add. Destructive interference is when waves arrive out of phase, the parts of the wave that are of opposite sign will subtract. The worst case is when the waves are 180 degrees out of phase and the waves cancel each other out.

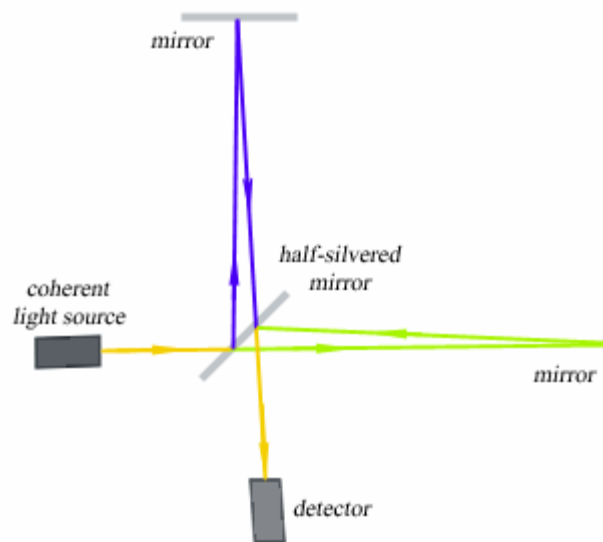

[18]

Figure 3-9 Interferometer

The above figure shows the setup of a Michelson Interferometer. Laser light, which is coherent and monochromatic, is projected upon a half silvered mirror which passes half the beam through and reflects the rest at a 45 degree angle. The laser beams then bounce off their respective mirrors and pass through the half silvered mirror once again and combine back into one beam. The beam is spread out and projected onto a piece of paper and a fringe pattern becomes visible. Figure 3-10 shows a fringe pattern.

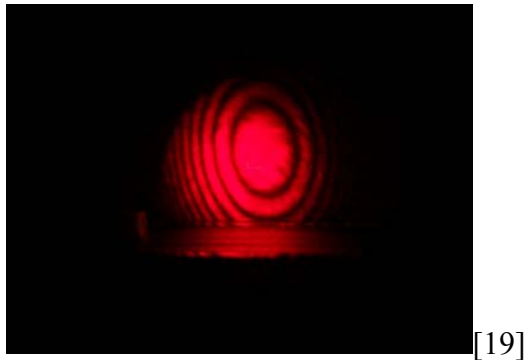

Figure 3-10 Fringe Pattern

When the beam the path lengths are exactly the same the beams will constructively interfere with one another resulting in a specific fringe pattern. As the distance of one mirror changes a number of fringes proportional to the distance moved will move across the sheet of paper. This setup can measure very subtle changes in distance such as those in a window moved by a conversation inside the room. An Interferometer is sensitive to changes as small as the wavelength light it is using, which for visible light is on the order of nanometers.

3.4.1 Correlation

Correlation is a method used to extract signal information from high levels of background noise. It involves transmitting a known pattern which may be much smaller in amplitude than the background noise. On the receiving end there may a poor signal to noise ratio, but using the technique of correlation can correct this.

In our case correlation could be achieved using a square wave. A laser pulsed in a square wave pattern will be projected on the window. The receiver would detect the backscatter that appears when the laser strikes the window. The information is all contained in our modulated wave that has hit the window and scattered, yet our detector is detecting all the light coming its way.

In order to focus on relevant information the received signal is multiplied by the same signal that is modulating laser beam. In the case of a square wave the received signal is multiplied by one or zero and the same rate that the beam is being pulsed at. This way we are only receiving the pulses that the beam transmitted along with some noise. A visualization of this technique is shown in the figure below:

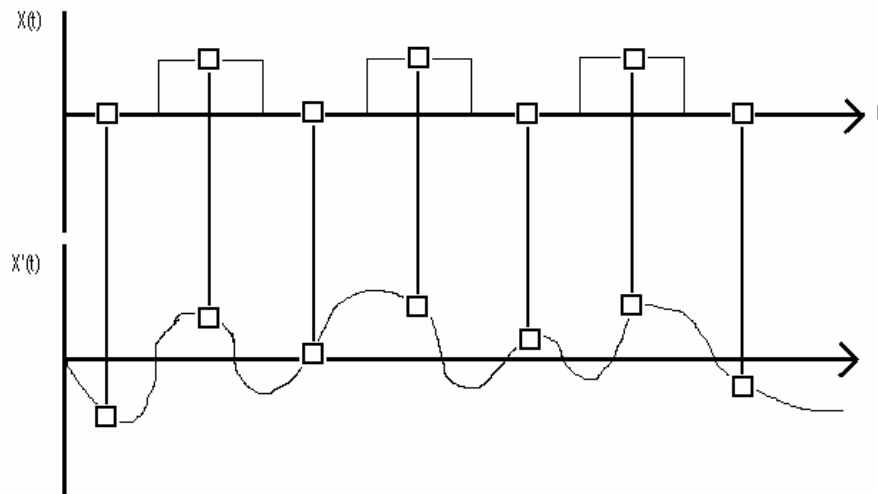

Figure 3-11 Correlation Graph

$X'(t)$ is the noisy detected signal and $X(t)$ is the pattern that modulates the laser. We are only interested in changes at specific times when we know our signal is present.

The mathematical equation for correlation is shown below. $Y(t)$ is the correlated output, T_p is the period of integration, $X_m(t)$ is the modulation signal, and $X_d(t)$ is the detected signal.

$$Y(t) = \int_0^{T_p} X_m(t) * X_d(t) dt$$

The next step in correlation is integrating the result of the multiplication. This would normally tell us how well the signals are correlated, the faster the integral grows the better correlated the signals are. In our case the amplitude of the square wave reflecting off the window will change as speech changes the angle the window. The changes in amplitude will affect the integral in pattern that is linked to the audio signal. If there is any uncorrelated circuit or optical noise present it will statistically average itself out to zero if enough square waves are integrated leaving the audio signal as only dynamic variable.

3.4.2 Spectrometry and Doppler Effect

The Doppler Effect determines how any wave changes frequency when it bounces off a moving object. Spectrometry is a method for determining the light's frequency.

The Doppler Effect changes light by lowering its frequency when it strikes an object moving away from it, and increasing its frequency when it strikes an object moving toward it. Spectrometry works with a prism, when light is passed through a prism it is bent at an angle depending on its frequency.

The Doppler Effect is relevant to our project because the frequency of our laser may change depending on if the window is moving forward or backward when the wave strikes it. A sensitive enough spectrometer could detect minute changes in frequency caused by the moving window. The changes in frequency could be linked to the audio signal.

3.4.3 Time of Flight

The time of flight method measures the position of an object by pulsing energy at it and measuring the time it takes for it to return. In our case the time of flight method would require very fast and sensitive equipment so that very small and fast movements of the window caused by speech could be tracked. If the position of the window were known at enough moments in time the audio signal could be retrieved by taking the derivative of the position.

4 Methodology

This section explains the methodology we used to develop a plan of implementation. Our project took place in six phases. We first brainstormed to develop a list of possible techniques we could use to solve our problem. Next we narrowed down the options using our project constraints and resources available as guidance. Once we had narrowed down the field to only the most feasible options we picked one and tried to prove the concept. After proving the concept we proceeded to refine the concept. The plan was to stop refining the project and begin to finalize it once we had met the projects goals or when time became an issue. Finalization included testing the prototype's specifications and limitations. The last phase in our plan was to offer any recommendations to anyone wishing to follow up on our work.

4.1 Investigation of Possible Implementation Methods

The first phase that we underwent was to come up with as many possible methods for implementation of our project that we could. None of the ideas were immediately rejected. A seemingly unfeasible idea may not be able to stand alone but it needs to be considered because certain parts of it may be applicable to another idea.

The ideas we came up with from brainstorming included interferometry, Walsh function correlation, time of flight, and Doppler shift. The basic theory behind these ideas is covered in the background chapter. To narrow down our choices we needed to find out which ones were the most feasible. We established feasibility by performing simple calculations. If the method worked in theory we enquired as to the cost of the equipment to measure the phenomena. If it was outside our budget the idea was disregarded.

4.1.1 Time of Flight

The first idea we examined was time of flight. The idea was to send out a pulse of laser light then determine the amount of time it took for the light to return. Since the distance from the laser beam to the window should change with the audio signal, the audio information could be retrieved.

The idea proved to be impractical. It works in theory, but instruments required to measure such small vibrations are beyond our resources for this project. Time of flight is

used in several range finding applications including radar, and even laser range finding. The most accurate laser range finders we found on the market were only accurate down to millimeters.

Name	Modulation	Meas. range	Accuracy	Meas. time
LaserTech.Impulse 100LR	Pulse (900nm)	0-575m	3 cm @50 m, white target	0.3-0.7 s.
Riegl FG21-HA	Pulse (904 nm)	2-600 m	+/- 5 cm	0.1 – 1s.
Riegl LD90-3100VHS-FLP	Pulse	2-200 m (reflectance 80 %)	+/- 2.5 cm	0.5 ms
LaserOptronix LDM500 MIL	Pulse	0-999 m	+/- 1 m	-
Leica DISTO pro	Sine wave	0.3 – 100 m	+/- 3 mm	0.5 – 4 s.
LaserOptronix PH30	Sine wave	0-30 m	+/- 5 mm	-

[20]

We were not able to determine exactly how far a window actually moves from human speech but we know from observation that it does not move millimeters. It comes down to the fact that the time it takes light to travel even a millimeter is so small that it would be impractical for us to analyze.

4.1.2 Doppler Shift

Doppler shift was the second idea that we examined. The idea is based on the fact that waves reflecting off moving surfaces return with slightly different frequencies. Measuring the change in frequency of returning light would give us the derivative of the position of the window. The position of the window is proportional to the audio signal.

We performed some simple calculations to determine how much Doppler shift laser light would experience as it reflects of a window moving distances on the order of micrometers. We concluded that the shift is so small that it would be impossible to measure the change with the available equipment. Unfortunately the Doppler shift of light is only significant if the velocity of the light source is significant relative to the speed of light, which the window motion is nowhere near.

4.1.3 Amplitude Modulation with Correlation

The next idea that we considered was to sense the small change in amplitude at a given angle to the window. As the window moves it vibrates in its various modes causing small parts of the window to change angle with respect to a reference point. The

amplitude of light gathered at the reference point is proportional to the angle change which is in turn proportional to the audio signal.

We determined that this method was feasible if we devised a way to detect very small changes in very small signals. A technique called Walsh function correlation was recommended by our advisor. We investigated the feasibility of the idea and found that it was within our means to create a system based on correlation. This technique is capable of retrieving extremely small signals that are even smaller than noise floor. The theory of this concept was discussed in the background section.

4.1.4 Interferometry

The final idea that we examined was interferometry. Interferometry measures interference patterned in beam of light that is split then recombined. It can be used as a very sensitive method of determining distance if one light path is of a known distance and the other is not. The fringe pattern created when the beams are recombined can be used to determine the unknown distance with accuracy on the order of nanometers – the wavelength of a laser. After considering our resources which included access to high precision optical equipment we determined that the interferometry approach was possible.

4.1.5 Proof of Concept

About 1/3 through the first term of our project we had narrowed the possible methods to down to interferometry and correlation. Ideally the next step was to experiment with each concept and decide which was better aligned with our project goals. The constraints of time and manpower however made this unfeasible. We decided to try correlation first; if it worked then we would refine the concept. If we could not prove the correlation concept we would fall back on interferometry.

We worked on the correlation concept, first by concretely proving the concept that light amplitude was proportional to angle change. This was done by mounting window on a vertical axis of rotation and measure light at our detector at different window angles. The experiment included a variation on an opaque surface, and a scratched section of a window. The full results of this experiment were shown in the background section. As discussed, the experiment showed that the angular distribution of

light was not uniform, and therefore a small change in angle of the window would result in an amplitude change.

This led us to the conclusion that if we could detect small enough levels of light accuracy, we should be able to use this amplitude modulation to retrieve our audio signal. This was the detection method that we decided to pursue.

4.2 Refinement of Design

Our correlation concept proven, we moved on to the refinement of concept phase of our project. Our plan for refinement was to replace all of our control functions with a digital signal processor then step through the circuit from the optics module to the audio driver replacing low frequency components with components better suited for high frequency applications.

After determining our detection method, we developed an idea of all the modules that would eventually constitute our project. The first module would drive the laser diode. Next, the optics would gather the faint traces of light gathered from the distant window. The light would be detected by the detector module and sent through a gain module. The signal would then be processed by correlating it with the Walsh function used to drive the laser. A digital signal processor could then be used to sample the signal, process it, and then output it through a digital to analog converter. Once the signal was cleaned up by the processor it would be sent to an audio driver stage and output to headphones.

4.2.1 Laser Diode Driver

As we chose a laser as the light source for our project, we needed to have some means to drive it. We looked into the possibility of using pre-made laser modules that drove the laser and collimated the laser beam. Although using such a module would have saved us a considerable amount of time, the prices of these systems were beyond our budget range. Ultimately we decided to implement our own laser diode driver circuit to power a laser diode of our choosing. We understood that laser diode driver circuits could be quite complicated, but strove to design one that was as simple as possible to fulfill our needs.

We also determined that we would need to modulate our laser beam with a square wave for two reasons. The first is that the correlation principle that we were trying to

exploit requires it. Also, but modulating the laser beam, the audio information we were interested in would be moved up in the frequency band, much higher than any other light source, so we could easily filter out the undesired light that we detected with a high pass filter.

4.2.2 Optics

The optical system we decided to implement consisted of a laser diode, several lenses and a window. We shone the laser beam through lenses to collimate the beam; then had that beam incident on the window. The light reflected back from the window then needed to be concentrated on to our photodiode, as we sought to create an optics module that delivered as much light to the detector as possible.

We considered two major ideas for light collection, which were the parabolic reflector and a Fresnel lens. The parabolic reflector acts as a satellite dish for light. Parallel rays of light traveling from a point in front of the detector enter and reflect off the surface of a parabola and are all focused to the detector. The cost of obtaining a quality reflector and the fact that a large reflective dish is not very covert were the factors that led to the idea being disregarded.

The Fresnel lens proved to be the superior idea. In theory it provides the same amount of light for its area, and we simply knew more about how well Fresnel lenses worked. We did not have the luxury of research time so we went with what we knew.

It is also important to note that we chose to use a laser in the visible spectrum. Ideally a device meant for covert use such as this would not use visible light since it could be seen by the party that is being eavesdropped upon. An infrared laser would be used for a final implementation of this device. We chose to use a visible laser however for ease of use in the laboratory experimentation we were conducting, as it would be more difficult to keep track of the location of an infrared laser beam.

4.2.3 Detection

We understood that we had a challenging problem in that we were trying to detect very small levels of light, the backscatter reflected from a window. Furthermore however, we also were trying to detect light at our modulation frequency which needed to be

relatively high. In detecting light, there is always a tradeoff of sensitivity versus responsivity, which we needed to adapt to our needs.

The first stage of our circuit needed to have a light detector. We were able to easily determine that our detector needed to be a photodiode, as they are the only type of detector with the time response we required. Both phototransistors and photocells are too slow. Photodiodes come in different types. The “active area” of a photodiode is the area of the photodiode that is sensitive to light. The larger this area is, the more light will be detected. The tradeoff is that this active area is part of an internal capacitance in the diode, so the larger the area the more capacitance is present. The larger this capacitance is the worse the response time of the diode. We chose a photodiode which we felt would be suitable to our needs, although it was not possible to know precisely what the best active area size was for our needs.

A photodiode acts like a current source when it is in reverse bias, putting out a small current linearly proportional to the amount of light incident on the active area. This current is very small, generally on the order of micro-amps. Considering we were trying to detect very small levels of light, we knew that we would need to carefully design circuitry to retrieve a signal from this small current in order to convert it back into audio.

4.2.4 Early Signal Processing

The problem of trying to extract information from a very small signal was the major issue in this project. We expected the size of the signal we obtained from the photodiode to be so small that it was smaller than the noise that was also in the circuit. For this reason we needed to use the correlation technique described in the background section.

Before we could do this however, we needed to perform some initial signal processing. We needed to remove any undesired light signal that was not from the laser. We decided the best way to do this was to modulate the laser beam with a high frequency wave. The laser should be the only light source detected at a high frequency, so a high pass filter should rid the signal of any undesired light information. Since our signal was so small we would almost certainly need to provide additional gain. We also anticipated

that other methods of early signal processing may present themselves to enhance the performance of the system even further.

4.2.5 Correlation

In order to extract a signal so small that it is likely smaller than the noise in the circuit, we needed to use the correlation technique described in the background section. This technique is described mathematically as the integral of two signals multiplied, the measured signal and a reference signal. We needed to achieve this mathematical operation in circuitry. First, we needed to be able to multiply the two signals. We already planned on modulating our laser beam with a high frequency wave for reasons previously stated. We decided to make this wave a square wave to make the correlation process simpler. Binary multiplication is relatively convenient in circuitry. Since it entails either multiplying by one or zero, that means simply to either let the detected signal through or let a zero through. This can be achieved fairly simply in circuitry with as little as one transistor.

We also had to perform the operation of integration. The most common manner in which to integrate a signal is using an op-amp integrator. At the beginning of each new integration period this integrator would need to be reset to begin the operation again. The more cycles of the modulation frequency are contained in one integration period the more robust the output will be, diminishing the noise content. At the end of each integration period, the value of the integral will ideally be linearly proportional to the amplitude of the detected signal, and therefore effectively a sample of the audio signal that we wish to reconstruct. This sample will then go into to digital domain for further processing.

Since we were trying to represent human speech with these samples, ideally we should have twice as many samples as the highest frequency we wish to capture. Human speech is mostly contained between 20 and 2000Hz, though it can go as high as 3600Hz. We decided to implement the system with a 4000Hz sampling frequency however, at least for initial testing. The correlation technique works such that the more pulses that are integrated per reset period the SNR is increased linearly. For this reason we strove for a modulation frequency of 4MHz, so we would have 1000 pulses per integration period, and hopefully a good SNR for further processing.

4.2.6 Digital Signal Processing

The purpose of the digital processing module is to provide control signals to the rest of the circuit, and to extract the audio signal from the correlated signal. When we first conceived the idea of using a DSP to replace several analog circuits we were not very knowledgeable about the DSPs on the market. Through some preliminary research consisting asking people who use DSPs what they thought, we came up with 2 major families of DSPs.

The two families were Texas Instruments DSPs and Microchips dsPICs. We had to make a decision quickly due to time so the criteria we used to choose a DSP was not extensive. The criteria we used to choose between our options were cost, ease of use, resources available at WPI, and the processors abilities.

Cost was an issue because we had a limited budget and DSPs with a lot of peripherals can get expensive. Ease of use was an important aspect of the DSP because we only had one term left to get it up and running. We included processor abilities we had a general idea of what features we were looking for including a fast clock speed, and analog to digital converter, and a digital to analog converter.

We investigated cost by researching on the internet as well as asking knowledgeable people. We came to the conclusion that most dsPICs cost under \$20. [21] The only information we had on TI DSPs was that the development boards cost \$395. After looking at the TI website it became clear that most of their products came in expensive packages and we opted to not sift through the website when we knew dsPICs were within our price range and available at Digi-Key.

As far as ease of use the dsPIC was the clear winner. The dsPICs can come in 28 or 40 pin DIP packages that can fit into proto-boards. The TI DSPs that we looked at all came in 44 pin surface mount. Another factor that we considered is that we both had experience with PIC microprocessors and we both had none with the TI chips.

The analysis of resources available at WPI to program and debug also favored the dsPIC. There was an in circuit debugger and programmer available from the ECE shop. The only TI chips we that we had seen programmed at WPI were attached to expensive development boards.

If the DSP could not replace much of the analog circuitry then it was not much use to us. To determine which family of DSPs had the abilities we required we started determining the I/O functions we wanted it to perform. Also at this point we knew that if the dsPIC could do what we wanted to be done we were going to choose it regardless of what the TI chip could do.

The DSP needed to take in an analog signal, convert it to digital, perform some processing and then output an analog signal. So we knew that we needed a DSP that had an A/D converter as well as a D/A converter. We also wanted it to generate a high frequency square wave to modulate the laser diode. This was not a problem for many of the dsPICs we looked at which had clock frequencies over 100Mhz without an external oscillator. We also wanted the DSP to reset the integral. This signal could just be a pulse from one of the I/O pins, well within the dsPICs ability.

Our final choice came down to battle between different dsPICs. We initially ordered a dsPIC 30F4013 because we overlooked the fact that it did not have a D/A converter. In fact none of the dsPICs had one built in.

At this point we face a dilemma as to whether to buy a digital to analog converter or build our own. We checked around with people familiar with DSP and found that it could be troublesome to get different ICs to connect to each other properly. We also were told that we could make a pulse width modulated PWM output and use a low pass filter to convert a digital signal to analog.

We decided to pursue the PWM path. Through online research we found that the dsPIC30F4011 had a PWM output pin built in, and subsequently ordered one. Within a week we had the AD converter and PWM output functioning together. Unfortunately we destroyed the AD converter when we tried to hook it up to the rest of the circuit.

The failure of the dsPIC30F4011 gave us two options, order another and wait a week, or build a PWM program from scratch on the dsPIC30F4013. Due to the time consideration we decided on generating our own PWM code because we thought it would take less than a week to create it. Hence the dsPIC30F4013 became our DSP.

4.2.7 Audio Driver

Our audio driver module was never integrated into the system because we ran out of time. The purpose of the audio driver was to amplify the DSPs filtered output signal to drive a speaker. The most important criterion for the audio driver module was ease it's of design. The module was not a critical part of our project and we did not want to spend much time on it. We decided on using the same IC as last years project, and got as far as implementing it on its own before more pressing needs in the circuit drew out attention elsewhere.

4.2.8 System Integration

We integrated our system module by module starting at the front end of circuit and working our way through to the end. We found that there is great importance in a well planned methodology for system integration.

During the integration of our system we would isolate a module and test it for functionality, then do the same with the next module. When both modules functioned worked we would combine them and check for functionality. After achieving functionality more modules were added until we reached the end of the circuit. Our system that we developed allowed us to better isolate problems, the times when we failed to follow the system we wasted hours trying to track down problems.

4.3 Summary

The methodology we used to complete our project had us starting off with a broad array of concepts and ideas that we narrowed down to a couple of concepts we thought were provable. We attempted to prove the one that was more inline with our project goals and succeeded.

From that point on we endeavored to refine the concept until we met our project goals or until time became and issue. We worked through each module and determined the general method for implementing each one. Then we worked to implement each of the modules before finally linking them up to form a final system.

When the time constraint put a halt to our design work we performed final testing to see if we meet specs and find the limitations of our system. The final phase of our project was to offer any recommendations on how to further refine the system.

Implementation

This chapter is a record of the implementation of the plan we developed in the methodology section. We will present all of the details of the system we designed to accomplish our objective. We will first present an overview of how the various modules in our system function together. Then we will get into the specifics of each of the modules. Within each module's section we will review its role in the system, list the options if any we had for its implementation, and explain how it was finally implemented including any problems we had along the way.

4.4 General Functionality

The following figure is our system block diagram which shows the overall depiction of our system and how the various subsystems interconnect.

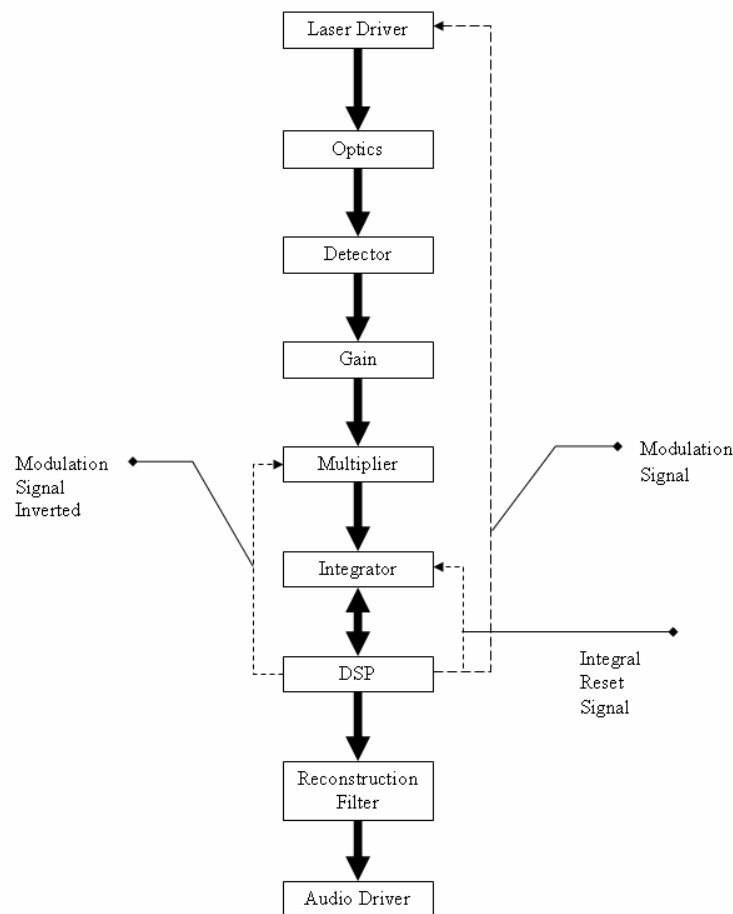

Figure 0-1 System Block Diagram

Our system collimates and modulated laser beam and projects it against a window, uses optics to focus that beam onto a receiver circuit, does some early signal processing, then correlates the signal to remove noise, digital signal processing, and reconstructs the analog audio signal before we drive a head phone speaker with the audio signal begin generated behind the glass.

We broke this complicated task into several modules to simplify the design process. The driver circuit will modulate a laser diode at the required frequency. Optics will be used to collimate light from the laser diode and receive light being reflected off the window. A very sensitive and noise free detector circuit is needed to sense the weak modulated light delivered by the optics. A gain stage is required to boost the signal up to more manageable amplitude. Then the process of correlation can begin, first by using a multiplier stage to find the product of the modulation signal and the detected one. Then we will use an integrator circuit to add up the area under the product signal, which is proportional to the audio signal.

The signal next moves into the digital domain. The digital portion of this project performs real time digital signal processing as well as provides several control signals used by the rest of the circuit. The DSP samples the correlated signal, quantizes the result then resets the integrator at the sampling frequency. The signal is then output via pulse width modulation. The DSP also provides the modulation signal for the laser diode and multiplier circuit as well as the inverse of the modulation signal also used by the multiplier. The output of the DSP is pulse width modulated and needs a reconstruction stage which consists of an analog low pass filter to return it to an analog signal. Then the signal can finally be used to drive an audio amplifier IC designed to power headphones.

4.5 Laser Diode Driver

The basic functionality of our laser diode driver module is shown below:

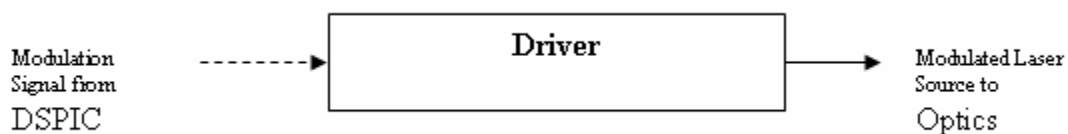

Figure 0-2 Laser Diode Driver Functionality

The purpose of this module was to drive our laser diode, modulating it with a pulsed waveform generated by the dsPIC.

The following circuit was designed in order to drive the laser diode that was selected.

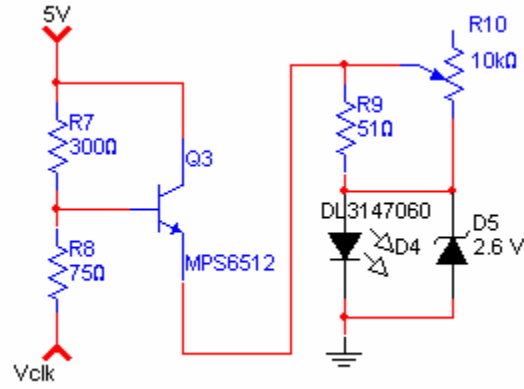

Figure 0-3 Laser Diode Driver Circuit

We needed to drive our laser diode with a modulated current so that it would pulsate at the modulation frequency. As mentioned in the background section, when modulating a laser beam it is important to not turn the laser completely off, because it takes a certain amount of time to turn back on which is significant at high frequencies. Because of this, lasers that are pulsed are generally pulsed between a bright state and a dim state.

We selected a 7mW laser with a wavelength of 650nm, which is red light. We chose to work with a visible frequency of light for convenience of prototyping in the laboratory. For a final implementation of a laser audio surveillance device an infrared laser should be used so that it is not immediately obvious that a laser is incident on the window.

We desired our laser diode to be switched between two states, bright and dim. The bright state corresponded to approximately 45mA of current through the laser diode, while the dim state needed to be about 30mA to ensure that it was always above the threshold current of our laser diode. By placing a resistor R9 in series with the laser diode, and applying a voltage to it, we could drive a certain current through the laser diode. By changing this voltage with time, we could modulate the laser diode with different amounts of current.

The modulation signal V_{clk} that we needed to work with was from the output of the dsPIC microprocessor, which was a square wave from 0V to 5V. Using the voltage divider with appropriate R7 and R8 values we were able to convert this signal to transition from 4.1V to 5V, the necessary voltages to drive the laser diode with the R9 that we chose. In order not to load down the voltage divider by drawing too much current we inserted an NPN transistor to provide current gain. After the 0.7V diode drop across the transistor the voltage was applied to the resistor and laser diode in series. R9 was chosen to ensure the right amount of current was driven through the diode.

Temperatures effects on the laser diode are something we also needed to consider. Varying the temperature linearly shifts the P-I curve of the laser diode. The currents that we wish to drive the laser diode with may need to be adjusted appropriately. We placed a potentiometer R10 in parallel with R9 so minor adjustments could be made. It is important to note that our laser diode driver circuit is too simple to be a robust solution. It was intended to be used for testing in the laboratory which had a fairly constant temperature. A final implementation of a laser audio surveillance device would need to have more complicated circuitry to negate these temperature effects and ensure proper light output levels. These temperature effects are certainly not to be overlooked, though we did not expect to see significant fluctuations in our laboratory.

We also included a Zener Diode in this circuit for protection of the laser diode. The maximum voltage the laser diode was rated for (which corresponds to the maximum current at room temperature) was 2.6V. We placed a Zener Diode in parallel with the laser diode to ensure that the voltage would never get higher than this value and damage the diode.

When this circuit was implemented we observed RC transient effects at high frequencies. These effects were mitigated by scaling down the R7 and R8 until the rise time was appropriate for the desired operating frequency.

4.6 Optics

The basic functionality of our optics module is shown below:

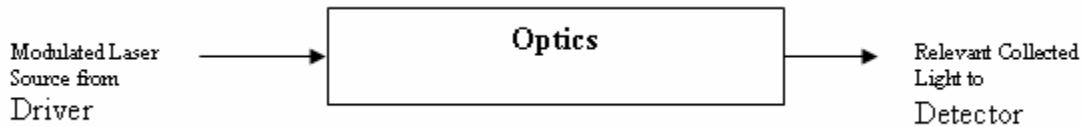

Figure 0-4 Optics Functionality

The purpose of this module is to take the modulated laser beam and reflect it off of the surface of a vibrating window, then collect the reflected light onto a photo-detector.

Before we could have our laser beam shine on a window surface we needed to shape the light from our laser diode into a tight collimated beam. The light coming out of our laser diode had a divergence angle of about 30 degrees. In order to change this into a collimated beam we needed to use a lens system.

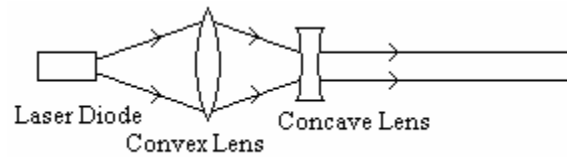

Figure 0-5 Collimation Optics

The light from the laser diode was first sent through a convex lens to take the diverging light and focus it back in on itself. When the beam reached the desired diameter (about 3mm) it was collimated using a concave lens. This lens had to be a specific distance away from the convex lens to achieve collimation, so it needed to be carefully adjusted.

The laser beam could then be directed onto the window. We used a window mounted on a rotating platform so we could test the system's performance when the laser beam was incident on the window at various angles without having to adjust the laser or any other optical components.

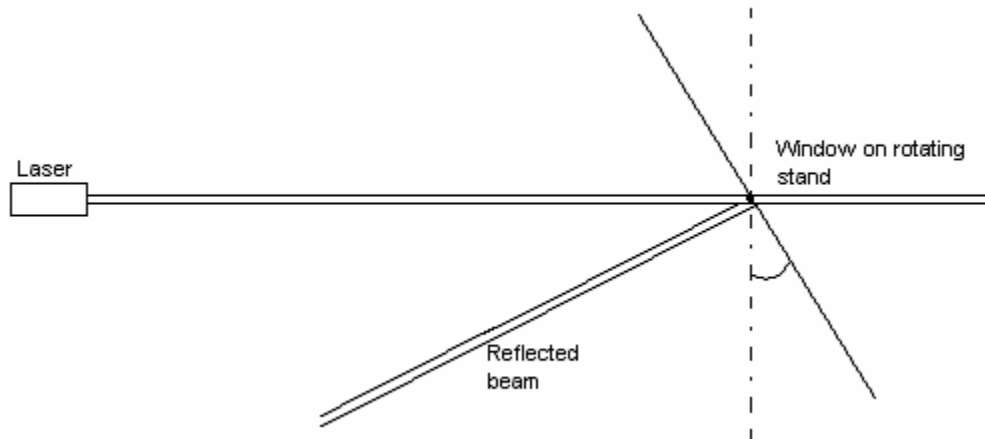

Figure 0-6 Laser and Window Configuration (Side View)

Our detector assembly was arranged with the laser, such that the detector would always be aimed at the same spot on the window as the laser, the backscatter dot.

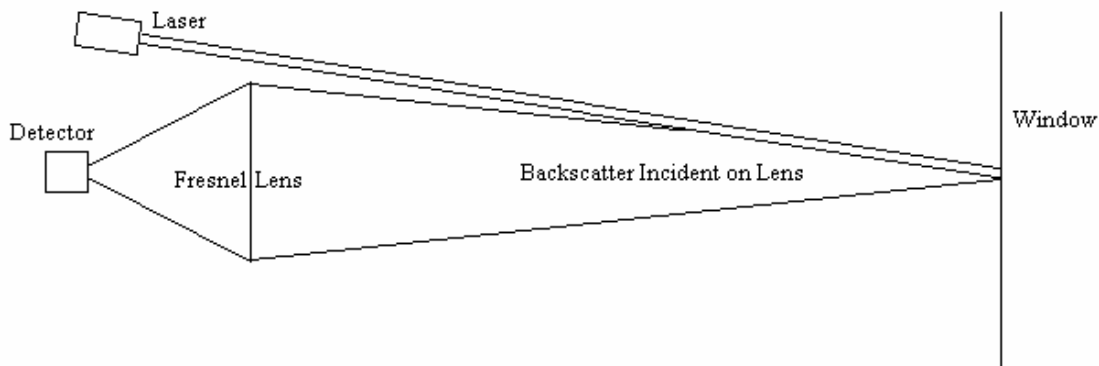

Figure 0-7 Laser and Detector Setup (Top View)

We used a large Fresnel lens in order to collect as much light as possible and focus it on the detector to give us the best signal strength possible. We found when we assembled these lenses that the Fresnel lens did not focus the light as tightly as we had hoped due to aberrations. We experimented with using an additional convex lens to try to decrease the radius of the spot. We had little success with this, as the aberrations had disrupted the integrity of the light. The improvement was small to negligible.

The picture below shows the setup of our system, indicating the locations of the key components.

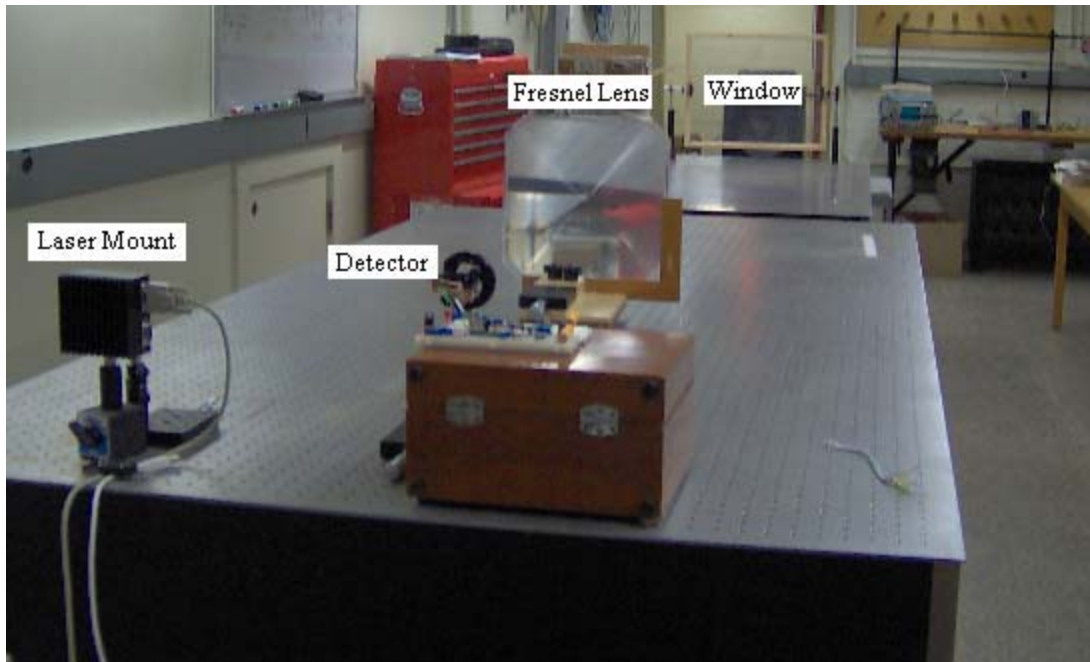

Figure 0-8 System Setup

For more pictures of the system and clearer pictures of each component, see Appendix 7.4.

4.7 Photo-detector Circuit

The basic functionality of our detector module is shown below:

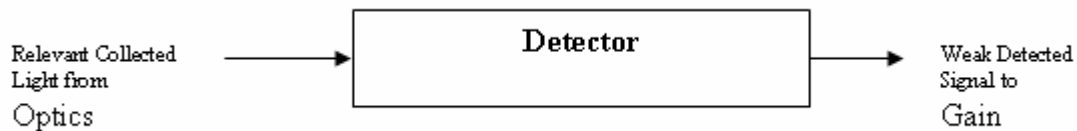

Figure 0-9 Detector Functionality

This module's purpose was to convert the reflected light focused by our optics into a voltage signal that could be used for further processing.

The following circuit was designed as the light detection circuitry. This circuit used a photodiode to convert light reflected from the window into a signal that could be processed by our circuit.

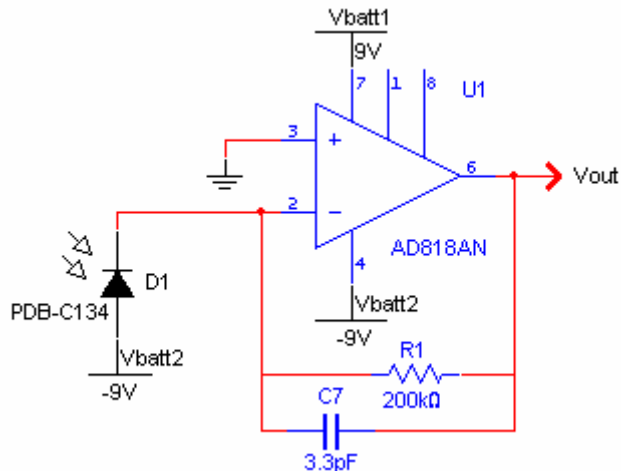

Figure 0-10 Photo-Detector Circuit

A photodiode in reverse bias will create a current proportional to the light incident on it, known as the photocurrent. Our photodiode was in reverse bias because its anode was at -9V and its cathode was at the virtual ground node of an operational amplifier. The photodiode we chose had a responsivity of approximately 0.5 Amps per Watt of optical power incident on the detector's active area for the wavelength of our laser, 650nm.

The op-amp configuration we chose to use is called the transimpedance amplifier, which is used to convert current signals, like what the photodiode creates, and convert it to a voltage signal.

This photocurrent is forced through R1, because ideally the negative terminal of the op-amp has infinite impedance. This creates a voltage V_{out} which is proportional to the photocurrent. The larger the value chosen for R1, the greater V_{out} will be via Ohm's Law. There are limitations to how large R1 can be however. First, the larger the resistance chosen for R1 the more thermal noise is introduced to the system. This is certainly undesirable as the signal should have as little noise as possible. Also, the resistance R1 in conjunction with any stray capacitance in the circuit creates an RC transient time response in V_{out} . Since the stray capacitance is generally fixed, the only way to improve the time response of V_{out} is to reduce R4, which reduced the amplitude of V_{out} .

The output of this stage should appear like the figure below.

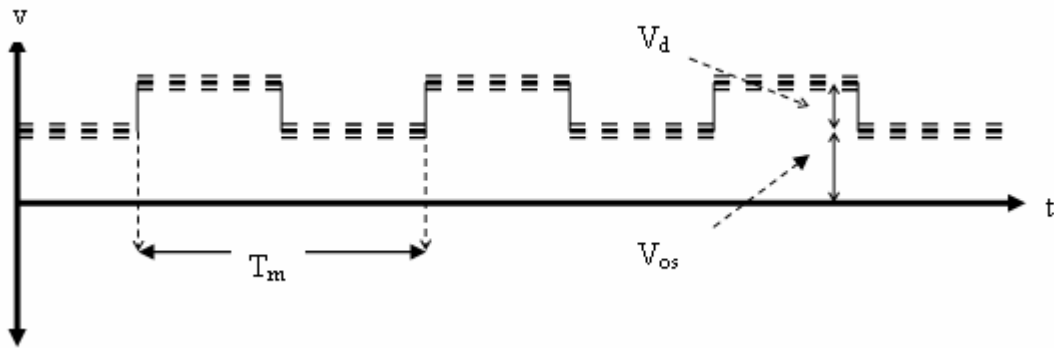

Figure 0-11 Theoretical Output of Detection Stage

The laser is modulated by a square wave so we expect to see this detected. There also should be some positive offset V_{os} due to any other undesired ambient light the laser detects. This signal will certainly have some noise on it, which will likely appear larger than the square wave that is detected.

Another issue that was prevalent with this circuit was the op-amp creating noise due to an oscillatory behavior known as “ringing.” This was lessened by the addition of a small capacitance $C7$ in the feedback loop.

The tradeoff of sensitivity versus response time is a major issue in optics, and is especially prevalent in this project because we are trying to detect very small amounts of light that is being modulated rapidly. Our first priority must be to ensure that the time response of our circuit is acceptable, and then use amplifiers to increase the size of the signal. The fact that the output voltage is so small makes the signal to noise ratio very small, so even when we amplify the voltage it is not immediately distinguishable from the noise that is also amplified. We used various techniques later in the circuit to remove this noise, including filtering and correlation.

4.8 Early Signal Processing

The basic functionality of our early signal processing module is shown below:

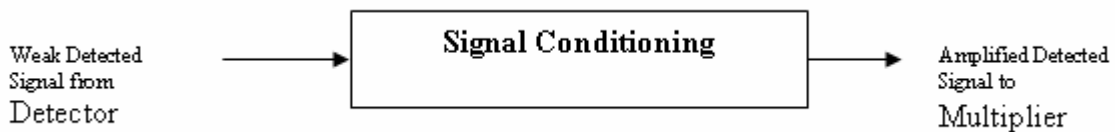

Figure 0-12 Early Signal Processing Functionality

This module's purpose was to take the small detected signal from the detection stage and perform operations on it so that it became ready for the correlation part of the system.

The first objective that this part of the circuit performed was to rid the signal of any undesired light that would be at lower frequencies such as sunlight (DC) or electronic lights (generally 60 or 120Hz). Since our laser light was to be modulated much faster than this, we could use a high pass filter to let only the laser light through. This circuit was implemented as follows;

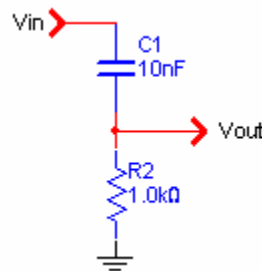

Figure 0-13 High Pass Filter Circuit

The cutoff frequency for this filter:

$$f_0 = 1/(2\pi * R2 * C1) = 16\text{kHz}$$

This cutoff frequency is acceptable as it is well above the frequencies to be blocked and well below the modulation frequencies we considered testing with. The output of this circuit should then look as follows:

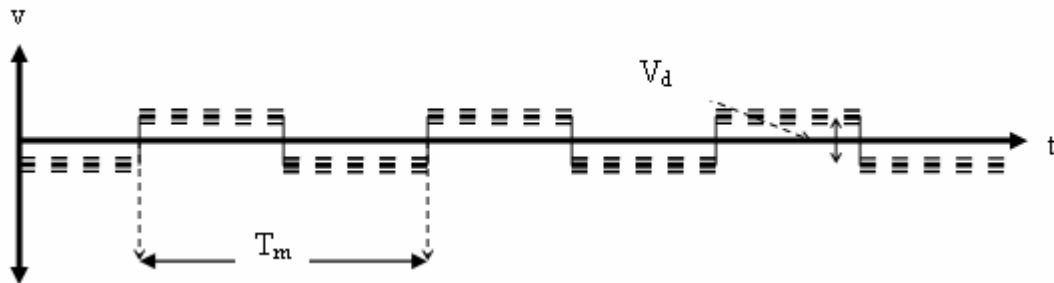

Figure 0-14 Theoretical High Pass Filter Output

Any DC offset or low frequency disturbance should now be removed from the signal, leaving the desired signal averaged about ground.

Next we needed to provide the signal with additional gain in order create a large signal much larger than the noise in the circuit, so that the signal would not be further deteriorated by noise in further stages. Any noise the signal already had on it however would be amplified along with the signal. This gain stage was implemented as follows:

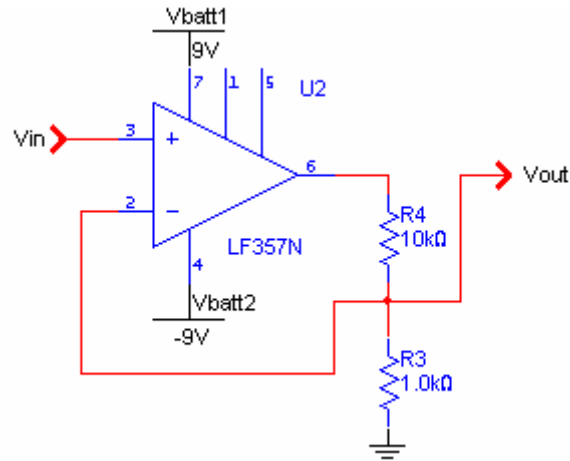

Figure 0-15 Gain Stage

The circuit used was a standard non-inverting amplifier with a gain of about ten to amplify the signal. The output of this circuit should appear as follows:

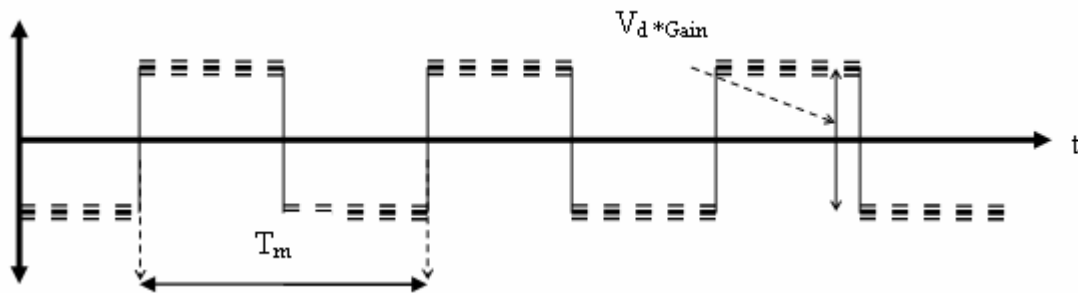

Figure 0-16 Theoretical Output of Gain Stage

The signal should be identical to the input signal, including any noise, but multiplied by the gain factor.

Next we decided to implement a clamping circuit, to take the output of the gain stage and clamp the bottom of the signal to ground. This would prove useful later when we needed to integrate the signal later, providing twice the area to be integrated for a stronger signal. This circuit was implemented as follows:

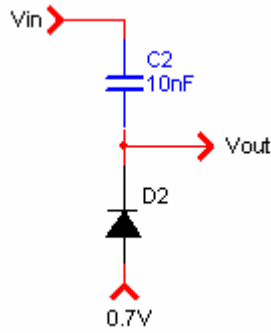

Figure 0-17 Clamper Circuit

The output of this circuit should be the same as the output of the gain stage, but with the bottom of the signal clamped to ground. Normally a clamper circuit of this nature would clamp its output to $-0.7V$ due to the voltage drop across the diode. For this reason we set our clamper to a $0.7V$ reference voltage to ensure the clamping was really to $0V$. To view the implementation of this voltage reference, see Appendix 7.2. The output of this circuit should look as shown below.

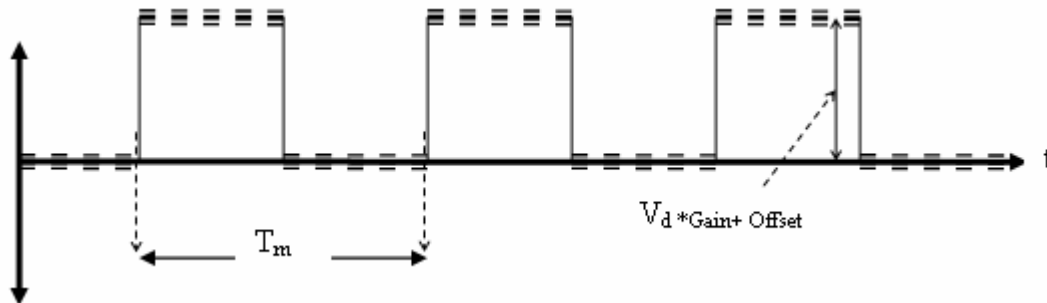

Figure 0-18 Theoretical Output of the Clamper Circuit

After all of these stages of signal processing, our signal was finally ready to undergo the process of correlation to rid it of the noise that overwhelmed it.

4.9 Correlation

The basic functionality of our correlation consists of two parts, multiplication and integration. The functionality of the multiplier is shown below.

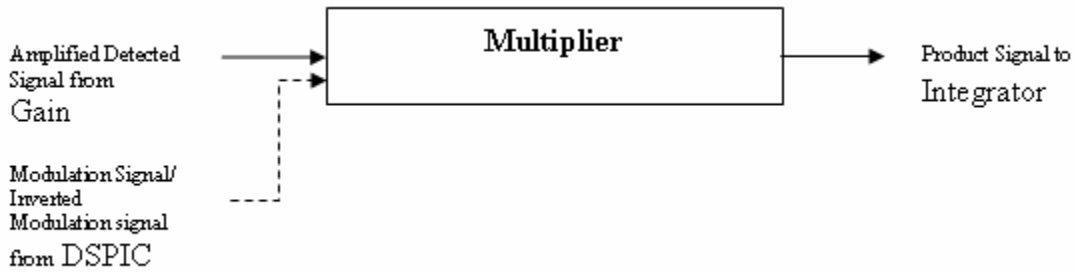

Figure 0-19 Multiplier Functionality

This module was realized as a circuit as follows:

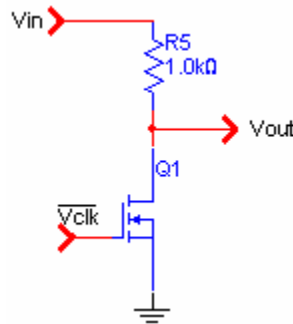

Figure 0-20 Analog Multiplier

This circuit either lets the input signal pass through to the output or sends ground to the output based on the inverted modulation signal which comes from the dsPIC. When Vclk is high, the laser out put is high and we desire to let Vin pass through to the output. Vclk' is therefore low which makes the NMOS transistor in this circuit act like an open circuit between Vout and ground. Vout is a high impedance node, so there is practically no current through R5 and therefore no voltage drop across it, so $V_{in} = V_{out}$. When Vclk is low however, we desire Vout to be 0V. Vclk' is high and the NMOS transistor acts like a short circuit between Vout and ground, forcing Vout to equal 0V.

The output waveform would then ideally behave as depicted below:

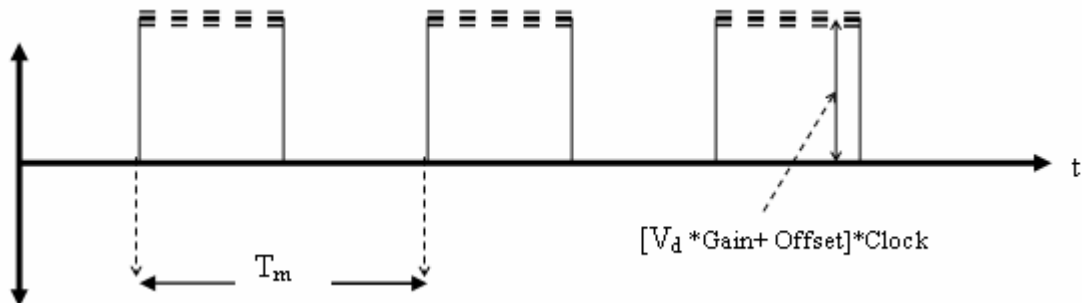

Figure 0-21 Theoretical Output of Multiplier

The result of which is the desired multiplication of the detected signal by the clock signal that modulates the laser beam.

Next this signal needed to be integrated to complete the process of correlation. The functionality of this module is as follows:

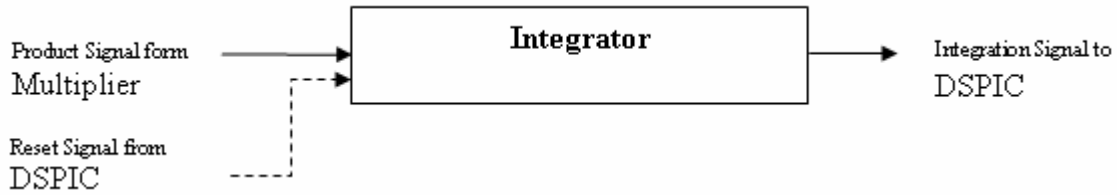

Figure 0-22 Integrator Functionality

This module was realized as circuitry as follows:

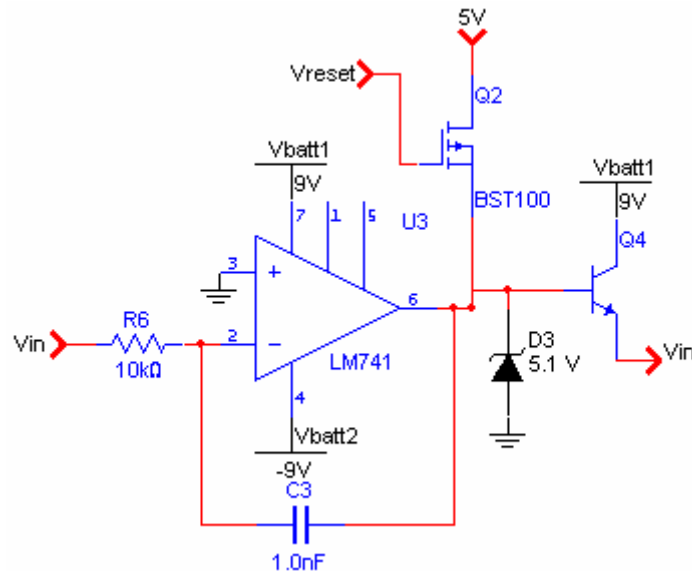

Figure 0-23 Integrator with Reset Switch

The main component of this module is a standard op amp integrator. The output of the op-amp in this configuration is as follows:

$$V_{out} = -1/(R6 * C3) * \int V_{in}(t) dt$$

So, the output of the integrator will be the inverted integral of the input, scaled by the chosen R6 and C3. We chose the values of R6 and C3 so the integrator would integrate at the desired rate.

Since the input of this circuit is the output of the multiplier, which is always positive, we would expect to see this integrator output decrease as it integrates until it hits the negative rail. This would not be very useful, which is why it is necessary to reset the

output of the integral periodically to some known value. In our case we chose 5V. The destination of the output of this circuit is the dsPIC's analog to digital converter, which needs an input voltage between 0V and 5V. By resetting the integrator output to 5V and knowing it always integrates downwards, we can assure this happens. The output of the integrator should appear as follows:

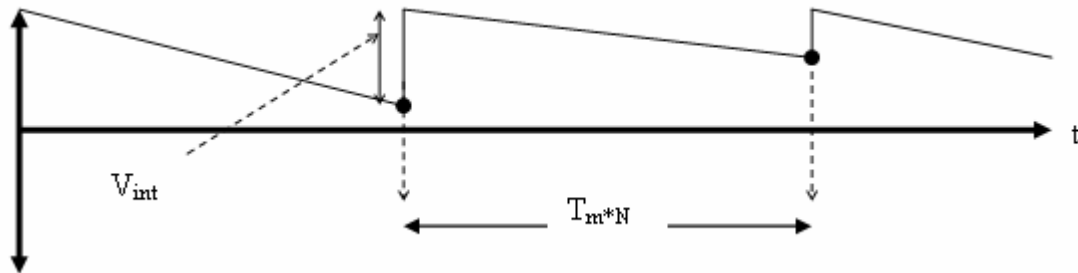

Figure 0-24 Theoretical Output of Integrator

The peaks of this waveform should correspond to the amplitude of the desired audio signal.

The reset action is performed by a PMOS switch, with an input signal V_{reset} from the dsPIC. When the integrator is integrating V_{reset} is high, making the PMOS act like an open circuit between the output of the op-amp and 5V. When the integrator needs to be reset, V_{reset} goes low and causes the PMOS to act like a short circuit between the output of the op-amp and 5V, resetting the output to 5V for the next integration period.

Since the op-amp was being supplied by +/-9V rails, it was possible that the output voltage could go below ground, which is outside the range that the dsPIC can interpret, and possibly even damaging to the dsPIC. For this reason we placed a 5.1V Zener diode at the output of the op-amp. This Zener diode ensures that the voltage stays between 0V and 5V.

We also ran into an issue where the dsPIC's analog to digital converter drew more current than the LM741 op-amp we were using could provide. We then decided to use an NPN transistor to provide current gain so this was no longer an issue. This transistor does introduce a 0.7V drop, however this small shift in the voltage range proved to be inconsequential as long as V_{out} did not get too low, which was easy to control.

4.10 Digital Signal Processing

The dsPIC30F4013 samples and converts the analog signal V_{int} , processes it, then outputs a pulse width modulated version of the signal. The dsPIC also provides control signals to laser diode driver, multiplier, and integrator. This section will present the exact setup we used to develop and implement dsPIC programs, and an in depth explanation of functionality of the final program.

The main functionality of this module is shown below:

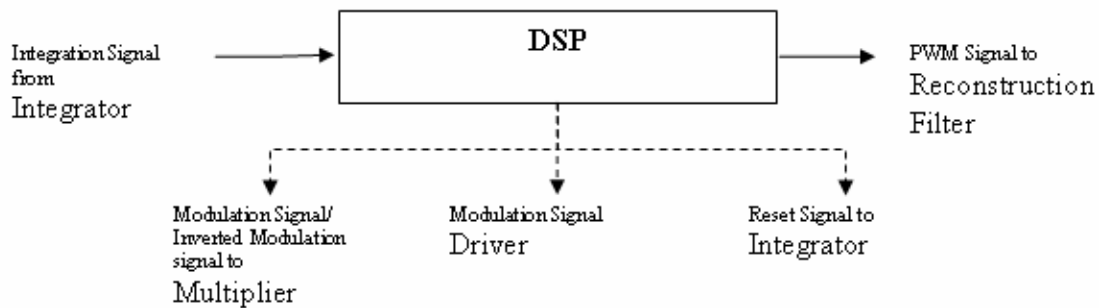

Figure 0-25 Digital Signal Processing Functionality

4.10.1 Setup

Using the dsPIC required several resources that are in the standard lab kit or available either at WPI or as shareware online. The resources include a development environment, a programmer/debugger, and special hardware to allow programming of the dsPIC while it's on a breadboard.

Our development environment was MPLAB IDE v7.22 with the Microchip C30 language tool suite which includes a C compiler. Using MPLAB we compiled our C code and simulated it with software debugger MPLAB SIM. The latest version of MPLAB IDE is available on the Microchip website free of charge. The C30 C compiler is available as a 60 day free trial online.

The programmer/debugger we used was Microchips In Circuit Debugger (ICD) 2 which was meant to be used with MPLAB. In debugger mode the ICD 2 programs special instructions into the dsPIC which allowed us to step through the loaded program and set breakpoints. In programmer mode the ICD 2 loads the program and is disconnected allowing the dsPIC to run itself.

We did not have a development board to work from so we needed to find a way to program the dsPIC directly from the ICD 2. We looked up the pin out of the dsPIC on the spec sheet and found which pins were used for programming. We then cut the cord from the ICD 2 into its individual wires and ran them to the appropriate pins on the dsPIC.

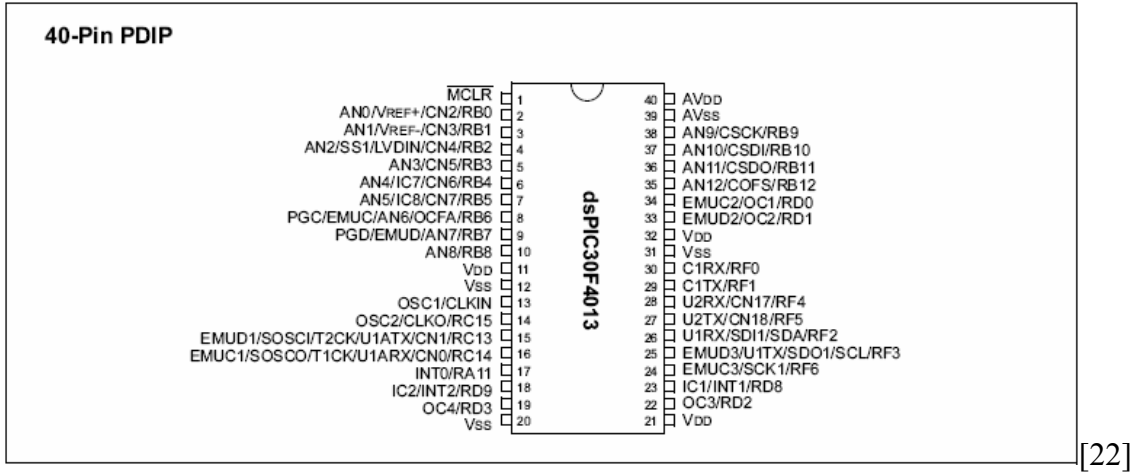

Figure 0-26 dsPIC Pinout

The wires from the ICD are numbered 1 through 6 and are connected to MCLR, Vdd, ground, PGD, PGC, and nothing, respectively. MCLR is pin 1 in the figure above, PGC, and PGD are 8 and 9 respectively. MCLR should also be connected to power with a 1k ohm resistor.

The circuit diagram for this part of the system is shown below:

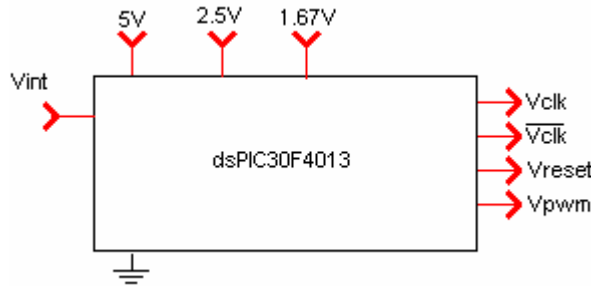

Figure 0-27 dsPIC Circuit Diagram

In our final system we used pins for power and ground, the PWM output, ADC input, the clock outputs, and the integral reset signal. In the picture above all pins marked Vdd and Vss were power and ground respectively. The PWM output was pin 16 PORTC14. The ADC input was pin 4 AN2. The voltage references for the ADC were pin

2 and 3, Vref+ and Vref- respectively. The clock outputs came from pins 28 and 29 PORTF1 and 4 respectively. The integral reset signal came from pin 22 or PORTD2.

4.10.2 The Program

The final program for the dsPIC performed all the signal processing and generated all control signals required without external digital components or oscillators. The dsPIC does not have multiple functional units so we did not have the benefit of running instructions in parallel either. The code multitasked by using timers, interrupts and calling assembly language functions. This section will first give a general overview of the code and then get into the details of each function and interrupt.

The program consists of a main function, square wave function, configuration function, an ADC interrupt triggered by a Timer 3 countdown, a PWM frequency triggered by timer 1 interrupt, and a PWM duty cycle interrupt triggered by timer 2.

The flowchart for the code is illustrated in Figure 0-28. The main program initializes I/O ports and calls the configuration function. Then main calls the square wave function that infinitely loops until the ADC interrupt is called. The ADC interrupt continues to generate a slower version of the square wave as it updates the duty cycle data for the next four pulses, gives the reset signal to the integral, and finally returns to the square wave. The PWM frequency interrupt is immediately called thereafter. The PWM frequency interrupt sets the PWM pin high then returns to square wave. After the appropriate amount of time the duty cycle interrupt is called and the PWM pin is set low. The output remains low until the frequency interrupt is called again. This cycle repeats for 3 pulses then the ADC interrupt is called for an update.

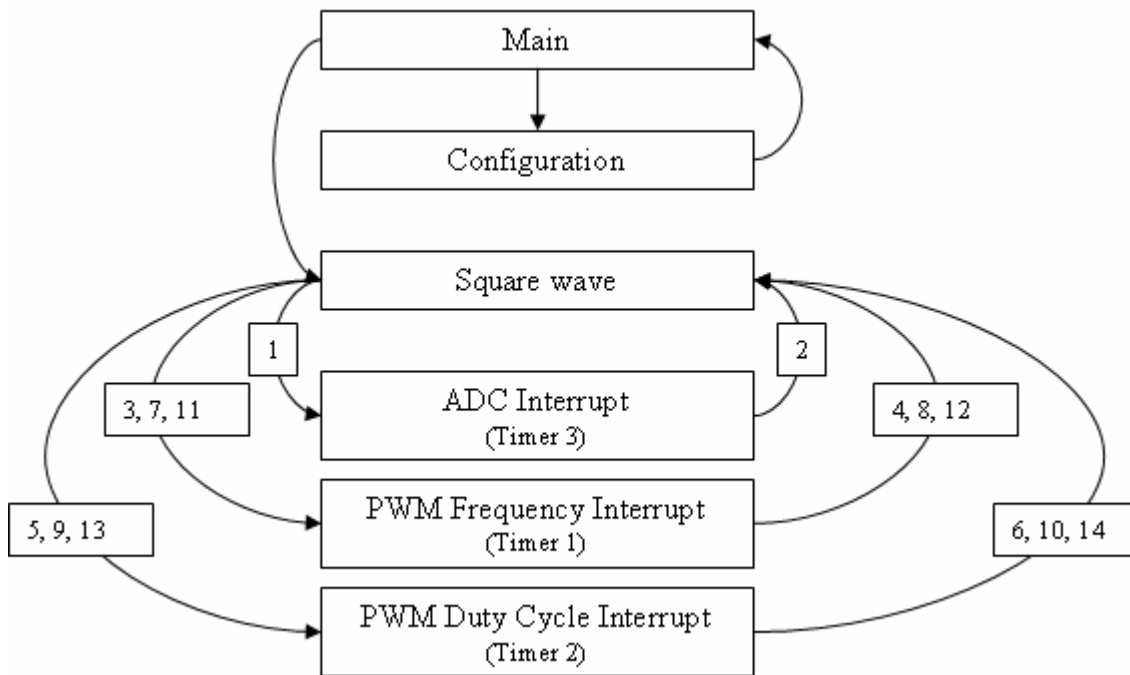

Figure 0-28 Program Functionality

4.10.3 Configuration

The purpose of the configuration function is to initialize the analog to digital converter, and timers 1, 2 and 3 to correctly implement the flowchart in the above figure. The dsPIC is designed to perform many diverse tasks; setting the right bits in configuration registers allowed us to specify its exact behavior.

The purpose of the ADC was to get one sample of the integral at its peak and convert it to a 12 bit digital number. We used AN2 as the input for the analog signal, we had to specify that it was analog pin and that it was an input pin. There are many pins on the ADC so we had to specify the AN2 was the one to be read by the sample and hold amp inside the dsPIC.

There were many options on how to trigger a sampling and converting of the analog input. We had to specify that a timer 3 time out triggers a sample convert progression. We had to specify that only one sample be taken per such progression and that it is represented as an unsigned integer. When the ADC was finally configured the correct way it was turned on.

Each of the timers needed to be set as 16 bit counters that count up to the value in a period register then reset to zero and call an interrupt. Timer 3's period is fixed and it

determines the sampling rate of the analog signal. Timer 1's period is fixed and it determines the frequency of PWM. Timer 2's period is initialized to 0, it determines the PWM duty cycle by changing based on the values sampled by the ADC.

Our final project ran off the dsPIC's 120MHz internal clock. One timer clock cycle is equal to 4 system clock cycles. We wanted to sample and reset the integral at 4 KHz. We used equation X to find the correct answer.

$$PR3 = \frac{SystemClock / 4}{Fs} \rightarrow 7500 = \frac{120,000,000 / 4}{4000}$$

The correct answer is 7500 but for reasons explain later on we made it the closest power of 2, 8192.

Timer 1's period determined the frequency of pulse width modulation. It was desirable to keep the frequency out of the range of human hearing but for reasons explained latter we decided four pulses per sampling was a good idea chose 2105 as Timer 1's period.

The final stage in the configuration process is to enable the ADC, timer 1, 2, and 3 interrupts after clearing their respective flags to avoid an instance vector to them.

4.10.4 Main

The purpose of the main function is to tie everything together. It calls the configuration function as well as configuring the reset of I/O pins used by the rest of the program. PORTC is used for the PWM output, PORTD is used for the integrator reset signal, and PORTF is used for the inverted clock signals, they must all be set to digital output pins. PORT F is loaded with a special value that ensures the negation operator will provide inverted clock signals. The remainder of main is and infinite loop that calls the square wave function.

4.10.5 Square Wave

The square wave function creates the clock signal that modulates the laser diode driver, and multiplier. The function is in assembly because only assembly is fast is fast enough to meet our original goal of our system which was 4 MHz clocks. Our project was never able to achieve 4MHz operation so we had to put several nop commands to

slow the clock down to 200 kHz. Removing all nop commands results in a 5MHz clock signal.

4.10.6 ADC interrupt

The ADC interrupt is multifunctional, it acts as the next pulse in the PWM output while simultaneously, sending a reset signal, modulating the clock, loading a new value from the ADC and calculating a new smooth factor.

After timer 3 times out it starts the sample/convert process, which takes 222 clock cycles to complete then it calls the ADC interrupt. The period of timer 3 is effectively increased to 8420. The reason that the PWM period is 2105 is to account for the sample and convert delay.

The ADC interrupt acts as the next pulse in the PWM output so it must last as long as one PWM period, 2105 clock cycles. This means that it is necessary that any instructions take up the smallest amount of time possible because that amount of time will always be fixed and reduce the dynamic range of the PWM output. The rest of the interrupt consists of code to dynamically adjust its high time and low time to help it blend in with other pulses.

The most important instructions in the ADC interrupt are those that load the next value from the ADC and convert it for use in the PWM output. The values from the ADC are 12 bit which means they are represented as being from 0 to 4096. The quantization levels are all between the 1.67V and 2.5V references. These references give us more resolution in the voltage range that we expect our signal to occupy. The references were created using voltage dividers; the schematics are available in Appendix 7.2 .

The period of the PWM is only 2105, if the values from the ADC were loaded right into the duty cycle register there would be overflow for half the values. The value from the ADC must be right shifted making the range 0 to 2048 with half the resolution. The reason for right shifting is that it takes up less instruction cycles than division.

Shifting the range to 2048 also has the benefit of allowing use to avoid overflow and underflow. The instructions in the ADC interrupt before the delay loops add up to 36 clock cycles. This means that the shortest any of the other pulses can be is 36 so the ADC interrupt can blend in with accuracy. We did not want to lose 36 levels of quantization so

we coded that pulse lengths always be 36 longer than they really were. So now the shortest a pulse could be was 36 and the longest was 2084, still below the 2105 limit.

The next step was to store the past duty cycle period into the “past” variable then move the new value between 0 and 2048 into then “present” variable. We use these two values and the number of pulses between updates to calculate a smooth factor that is added to the duty cycle after each pulse. This means that the most recently read value will not actually be the length of the pulse until the next interrupt is called. The pulses in-between will slowly approach the new value from the old value.

The rest of the interrupt consists of the delay loops that try to make the interrupt blend in with the other pulses. There are two delay loops; the first one is followed by an instruction to end the duty cycle, the next loop keeps the duty cycle low for the remainder of the interrupt.

The interrupt always lasts 2105 clock cycles. We calculated that it would take around 275 iterations through a “for loop” to reach 2105 clock cycles every time. The goal was have to high time equal the amount of high time prescribed by the previous value read by the ADC. We had to make the ratio of high time to low time translate from a 2048 point scale to a 275 scale. Instead of using 275 we converted it down to 256 so that values would map more accurately from a 2048 scale. The 256 iterations of the delay loops caused the interrupt to last almost 2105 instruction cycles so several meaningless delay lines were added at the end of the interrupt.

Through experimentation we found that 256 iterations divided between 2 “for loops” was the same as all 256 iteration given to one loop. The value of the index in the “for loop” is derived from the previous value that was sampled. The past value was right shifted 4 times to bring it down to the 256 point scale. The index for the second loop was defined as 256 minus the first delay number; this was done to maintain a constant duration for the interrupt. Rather than waste the time during the delays the “for loops” negate PORTF which continues to modulate the systems clock and inverted clock.

The other responsibility of the ADC interrupt was to create a reset signal that allowed the capacitor in the integrator to drain after its value was sampled by the ADC. This reset signal is taken care of by starting the reset signal at the beginning of the ADC

interrupt and ending it at the end, therefore we did not waste any time with a meaningless delay.

The final instructions in the interrupt clear take care of interrupt calling logistics and sync up timers 1 and 3. The interrupt must be clear so that it does not start over again at the end. Timers 1 and 3 should be at 2105 as soon as the PWM output is sent high at the end of the interrupt, but the timing between timers gets thrown off from the sample and convert time so it needs to be synced up every time the interrupt is called.

4.10.7 PWM Frequency and PWM Duty Cycle Interrupts

PWM frequency and PWM duty cycle interrupts are used to control whether the PWM output is high or low. Timer 1 controls the PWM frequency interrupt and timer 2 controls the PWM duty cycle interrupt. The general idea is that the frequency interrupt basically sets the PWM output high then returns to the square wave function until timer 2 times out and the duty cycle interrupt is called which sets the PWM output low.

The PWM frequency interrupt controls the behavior of the duty cycle interrupt. The first instruction is to set the PWM output high. Then the smooth factor is added to timer 2's period register.

The smooth factor was calculated in the interrupt and can be either negative or positive depending on the past and present values read from the ADC. The difference between the values was divided by 4 so adding the smooth factor each pulse ensures a smooth transition to the new value by the time of the next ADC interrupt.

The next step is to set timer 2 to timer 1's value + 11. The reason for doing this may not appear clear at first, it has to do with the action that timer 2 takes when it times out and calls the interrupt as well as the behavior of timers when you are writing values to them.

The problem is that the value in timer 2's period register is the amount of time that the high duty cycle should last. However there is a delay between the timer 2 timeout and the PWM output being set low. When timer 2 times out it reaches its maximum value then returns to zero, then a branch is required to reach its interrupt which take 6 more cycles before the PWM is actually set low.

Two more of the 11 are added because when the timers are synced up the one being written too does not increment for 2 instruction cycles. The rest of the delay is added because when the clocks are synced up the PWM output has already been high for 3 clock cycles.

The next step in the PWM frequency interrupt is to make sure that smooth factor addition has not made the timer 2 period register less than 36. If it is less than 36 the value is set to 36. Looking back it would have been wiser to say it equals itself plus 36.

The final step in the PWM frequency interrupt is to take care of its and the PWM duty cycle interrupt logistics. The PWM frequency interrupt clears and enables its own and the PWM duty cycle interrupt flag.

When timer 2 times out and the PWM duty cycle interrupt is called the PWM output is set low and the duty cycle interrupt is disabled until the frequency interrupt enables it again. The reason for doing this is to make sure that no unnecessary interrupts are called for the duration of the PWM period.

The whole system works for 3 cycles then is updated by the ADC interrupt that acts as the 4th pulse and adjusts its high and low time to mimic the pattern. Figure 0-29 below shows how the system ideally works.

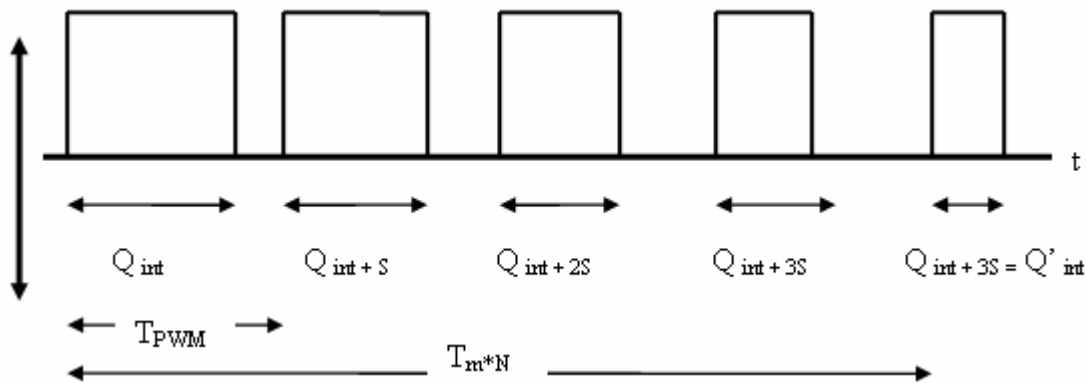

Figure 0-29 Theoretical Output of Vpwm

Q_{int} is the quantized value of integrator and is updated during the ADC interrupt. T_{pwm} is the period of one high/low cycle. The long period at the bottom represents the N periods of the system clock that occur between updates. S is the smooth factor that is added to the value in timer 2s period register every pulse. After adding 4 smooth factors the duty cycle will be equal to the value most recently read by the ADC.

4.11 Output Stage

The output stage takes the PWM waveform from the dsPIC and filters it to get rid of the high frequency pulses to extract the low frequency information related to the width of the pulses. The output stage consists of 3 cascaded low pass filters. The figure below shows the schematic:

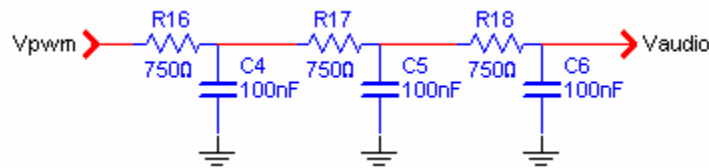

Figure 0-30 Reconstruction Filter

The cutoff for each of the low pass filters was around 2000Hz. The cutoff of the filter is determined by the equation below:

$$f_0 = 1/(2\pi * R2 * C1) = 2100\text{Hz}$$

We needed such a low cutoff because the PWM frequency was so low that in order to suppress it we needed to sacrifice the desired frequencies around it. The 3rd order filter does not give a steep cutoff so the 8 KHz PWM will not be suppressed much. One advantage though is that the other frequencies in the human hearing range will still be detectable.

Due to time constraints we did not implement an actual audio driver. Our original goal was to use our reconstructed audio signal to drive a speaker or headphones. Deciding to focus on the main principle we were trying to prove, retrieving an audio signal from backscatter, we did not have time to implement an audio driver, which would have been the final phase of the system.

4.12 System Integration

After all of the individual components of the circuit became functional we were able to combine all of the individual modules into one system. The overall circuit diagram is shown on the following page. Once the system was fully integrated we were able to commence testing to observe the performance of the system.

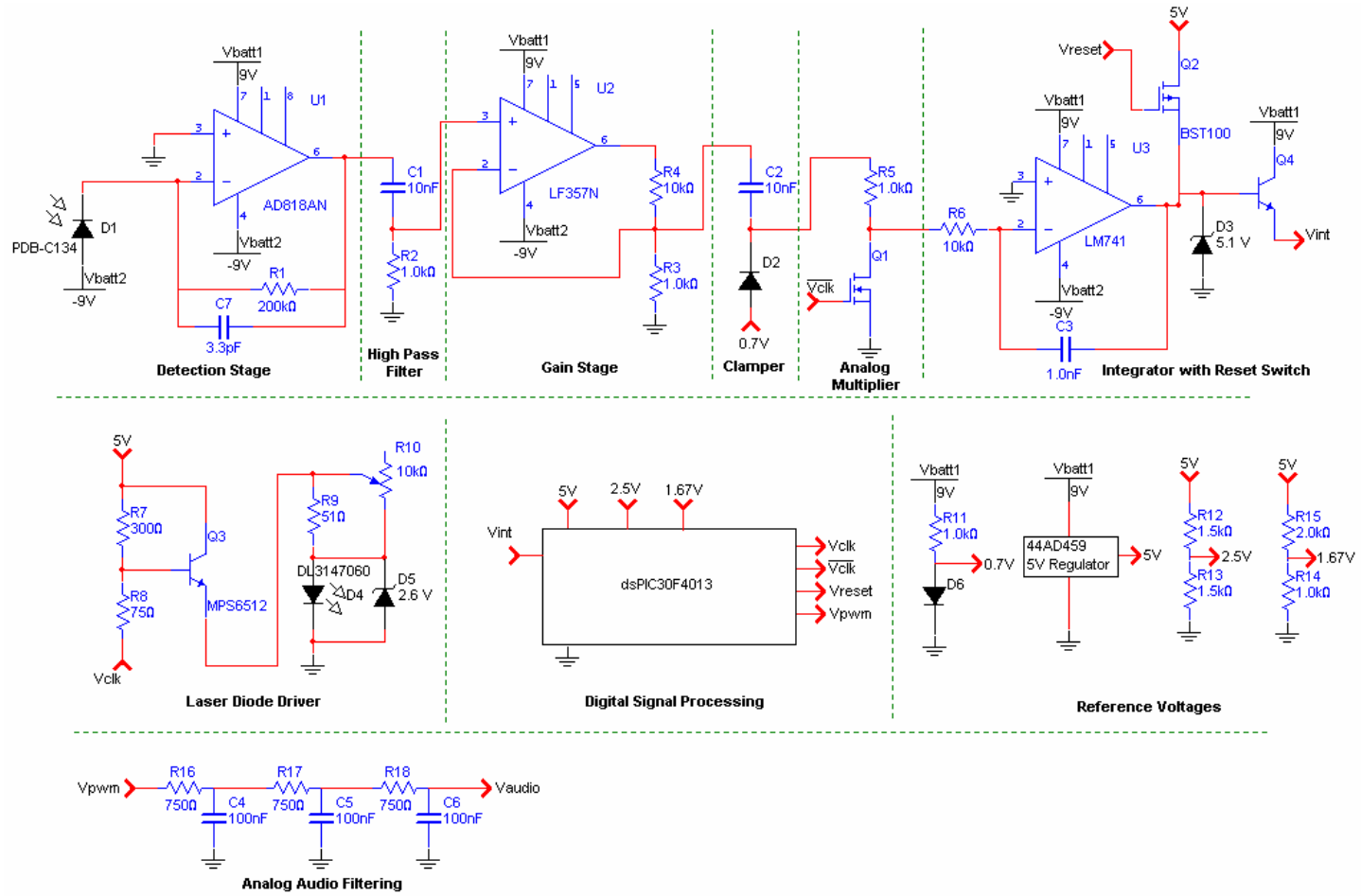

Figure 0-31 Full Circuit Schematic

5 Performance

Once our system was fully integrated and observed to be functional we performed tests to determine the degree to which our device functioned as predicted. Unfortunately, the process of research, design, implementation, and modular testing took far longer than expected, and we were therefore unable to complete this project to the desired degree. In this section on the device's performance, we will present the waveforms present in the circuit. Many of these waveforms vary from the ideal representations of them in significant ways. Much of this behavior we understand, but due to time constraints were not able to fully pursue solutions to all of these problems. In this section we will explain the performance of the system, where it varies from the ideal, the reasons why this is the case.

5.1 Laser Diode Driver

The laser diode driver circuit that we implemented is somewhat troublesome to judge in terms of performance. When modulating a laser at a high frequency, the only way to view its light output is by using a photodiode, which is subject to its own limitations. The detector circuit we were using had some issues at high frequencies at high frequencies, so it was difficult to ascertain how the laser itself was performing.

One useful waveform to observe however is the voltage across the laser diode. The current through the laser diode is what we were really interested in, since the light output power is a function of current, but the voltage across the laser diode is related to the current. Following is a graph of the voltage across the laser diode:

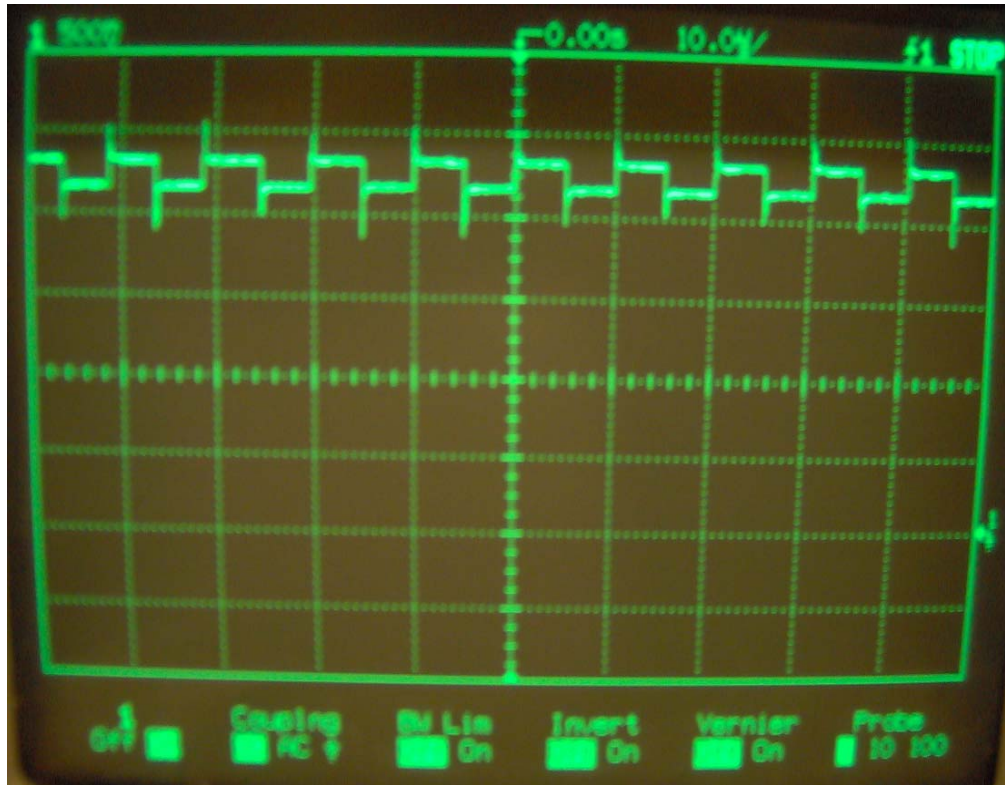

Figure 5-1 Voltage across Laser Diode

As shown, the voltage across the laser diode fluctuates from approximately 2.1V to 2.3V, which corresponds to the specifications sheet's voltage values for the currents we desired. A non-ideality that is visible here however is a voltage spike present upon each transition. The voltages are well within the range that is safe for the laser diode, however a spike in voltage likely means a spike in current, which is not what we intended. We experimented using a resistive load in place of the laser diode and these spikes were still present. This leads us to believe that the problem is not due to the laser diode and is most likely due to the either transistor in the circuit or the Zener diode. We did not wish to run any tests without the Zener diode for fear of destroying our laser diode. In the end this behavior was not one that we could fully investigate, although it did not appear to cause any problem. The light we detected with our photodiode did not have any voltage spikes present.

5.2 Detection and Early Signal Processing

The early stages of the circuit proved to be the most troublesome, and much time was spent in order to improve this portion of the circuit. Through the very end, we never

were able to achieve the degree of functionality desired. For much of the testing of this part of the circuit, we used the laser beam directly incident on our photodiode in order to provide us with a large signal that was above the noise floor. As discussed the signal generated from backscatter is generally so small that it is not visible until after correlation takes place.

The following figure shows the output of the transimpedance amplifier detection stage.



Figure 5-2 Detector Stage output Voltage (No Capacitor)

As predicted this waveform is a square wave with a significant DC offset due to ambient light. The non-ideality present is the noise on the wave. This is oscillatory noise from the op-amp. This picture was taken with no capacitance in the feedback loop of the transimpedance amplifier.

Adding a capacitance in the feedback loop can help with ringing noise. This produces the waveform that follows:

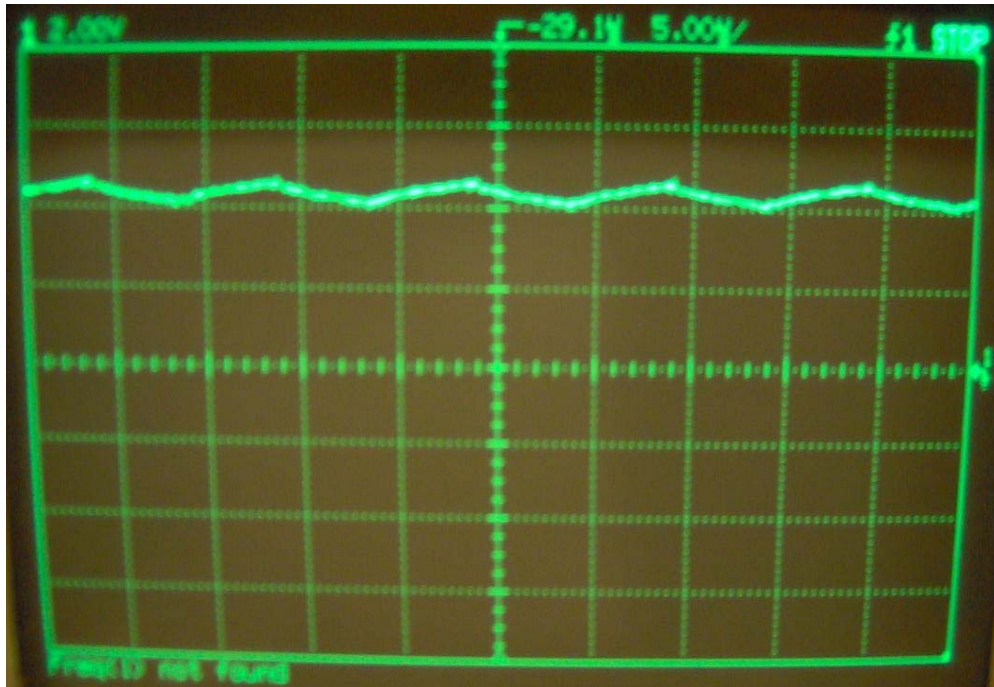

Figure 5-3 Detector Stage output Voltage (With Capacitor)

Now the waveform observed is a lot more stable, with no noticeable ringing noise. It is also clearly visible that there is a dominant RC time response taking place. We used a capacitance of 3.3pF (three 10pf capacitors in series) and the above waveform was observed. This was the smallest capacitance we had available. Unfortunately this was a late development so we could not fully pursue its resolution, but further reducing the capacitance and possibly the resistance should improve the response. Regardless, the above waveform's amplitude was linearly proportional to the audio signal, and free of ringing noise, so it proved useful. Ideally however, we would like to have this waveform such that it resembles a square wave.

The high pass filter we implemented did not have any major functional issues. Below is a waveform of the output of this part of the circuit.

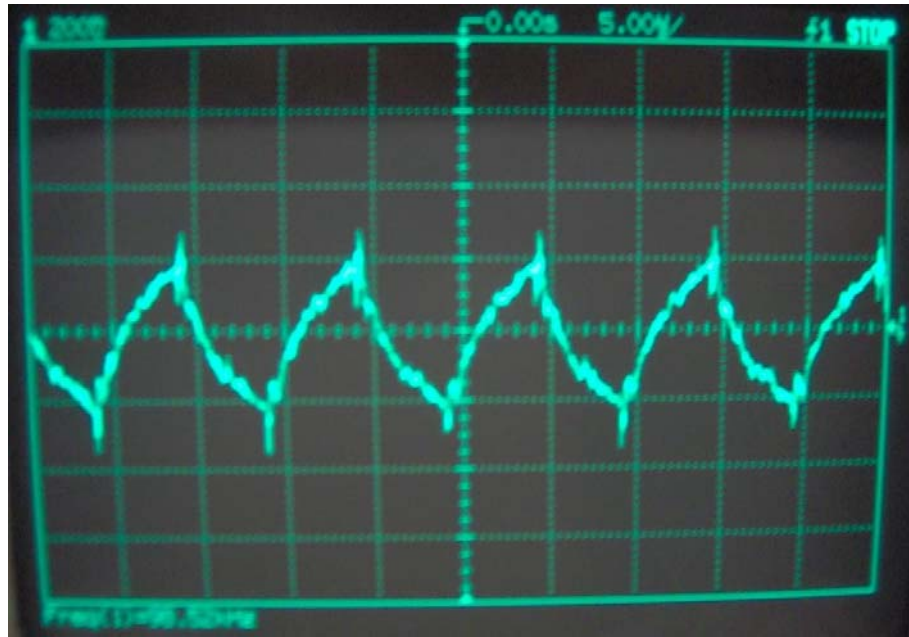

Figure 5-4 High Pass Filter Stage Output

Now the DC component of the signal has been removed as well as any low frequency noise. Zooming in further in voltage we can see that the signal is certainly not free of noise. The biggest contributors of noise are spikes that occur on each clock transition. This type of noise is an issue in many systems that use both analog and digital electronics. We have observed such noise to occur via two paths. Digital devices that suddenly change their current draw will create noise on the voltage supply rails due to loading. This can be helped by putting capacitance between supply rails to stabilize them. Also, these fast transitions have high frequency content which can lead to RF issues, with the circuit radiating RF energy and picking it up as wires act like antennae. Thermal noise is also an issue, which is why it is generally a good practice to keep all resistor values as small as possible (though this trades off with power considerations).

The following figure displays the output of the gain stage of the circuit:

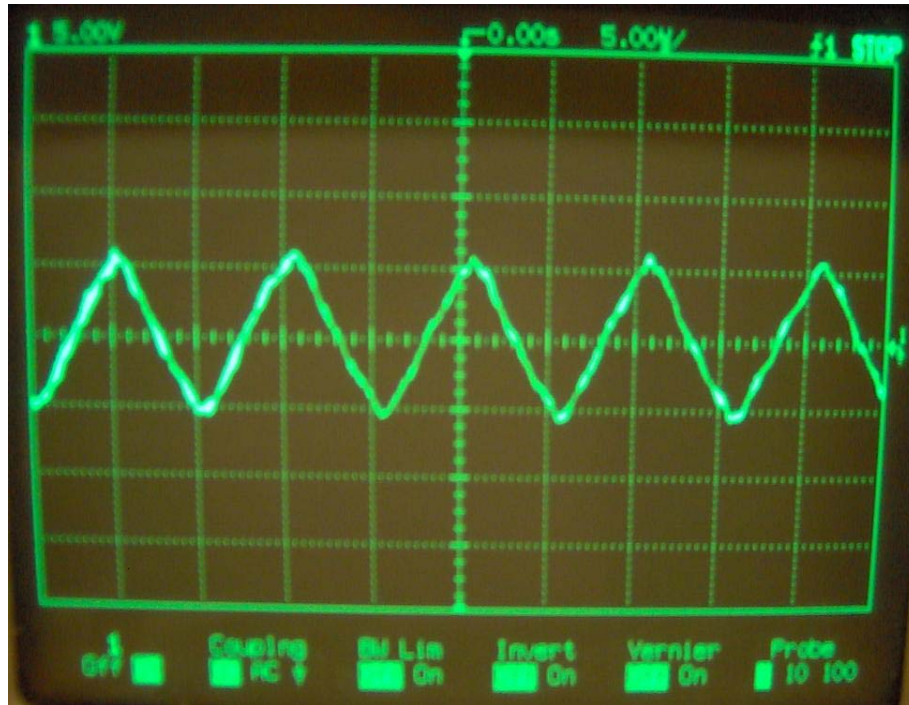

Figure 5-5 Gain Stage Output

This picture displays the basic shape of the waveform that it was supposed to amplify, with the desired gain factor. Apparently there has been some distortion, as the part of the signal that did appear curved now appears linear. We were unable to determine the cause of this phenomenon. It is not slew rate limiting as we first guessed, based on the slew rate specification of the op-amp we were using. As long as the signal's amplitude was linearly proportional to the light signal however, the correlation operation should work.

The following waveform displays the output of the clamper stage:

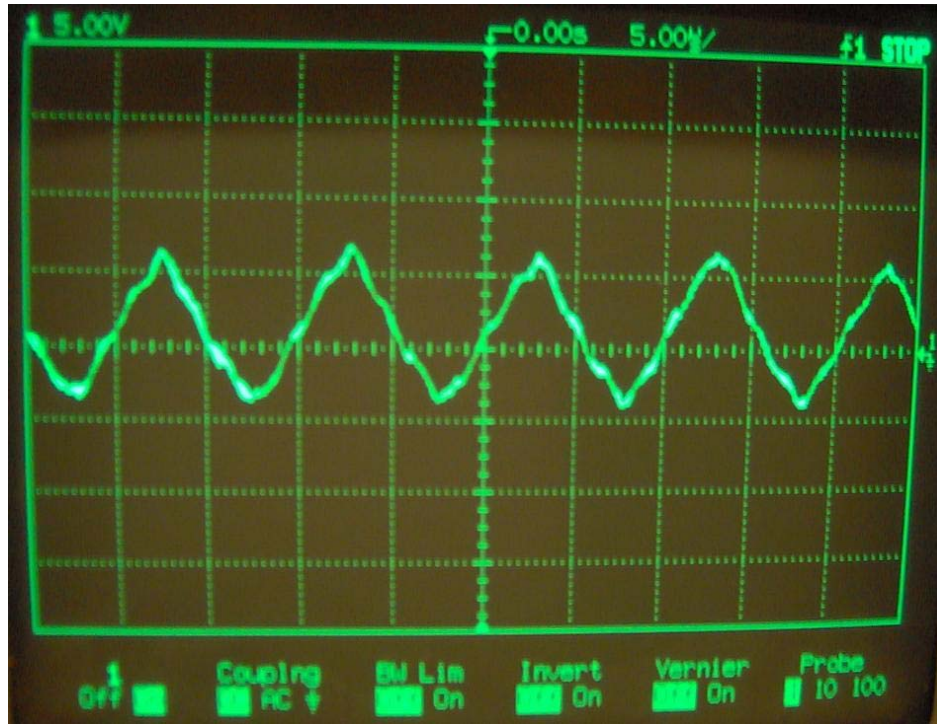

Figure 5-6 Output of Clamper Stage

The output waveform of this stage certainly has been given a positive DC shift as desired, although not enough to bring the signal to be clamped at ground. We found this to be a strange occurrence that we only observed on the day we took these photographs. Previously our clamper had been working as desired. We did not have time to fully resolve this issue; though we hypothesize that changing the value of the capacitor in the clamper circuit may affect the DC offset.

5.3 Correlation

The output of the multiplier module waveform is depicted in the following figure:

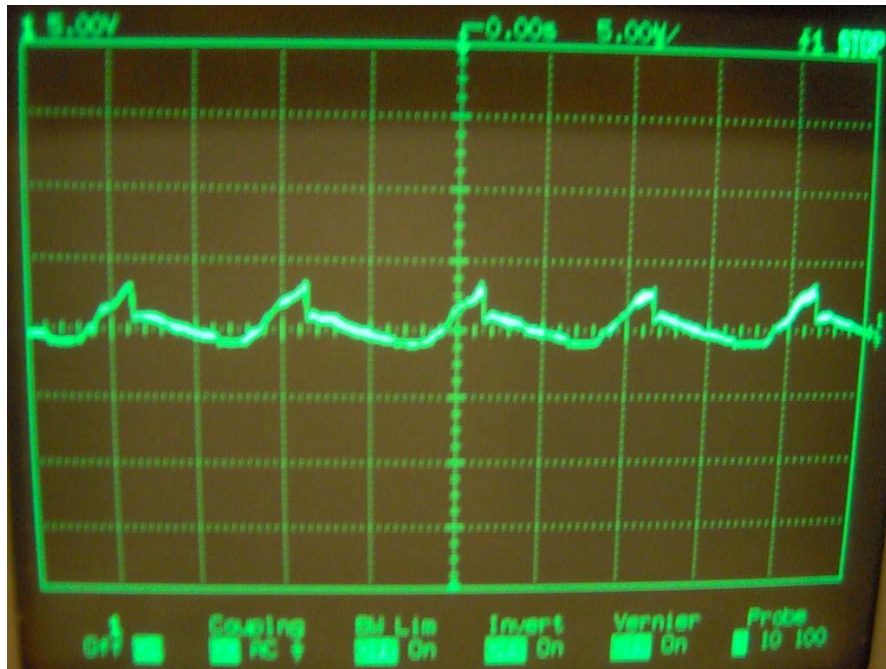

Figure 5-7 Multiplier Output

This waveform apparently deviates quite a bit from the ideal output that we observed in Figure 0-21. When the Vclk is high, the multiplier is supposed to let the output of the clamper pass through. We can see this behavior to some degree, although once Vclk transitions to being low we observe that the signal does not become ground as desired, rather it takes a moment to transition to ground. At the frequency we were operating at however, this transition took a significant amount of time. This behavior, like the strange behavior of the clamper was not observed until the day these pictures were taken. We hypothesize that this observation is a manifestation of the same behavior. Since the output of the clamper becomes negative, the voltage from the drain to the source of the NMOS becomes negative, which causes the switch to function improperly. Our circuit was designed assuming the clamper output would stay above ground.

The following figure displays the output of the integration stage of the circuit:

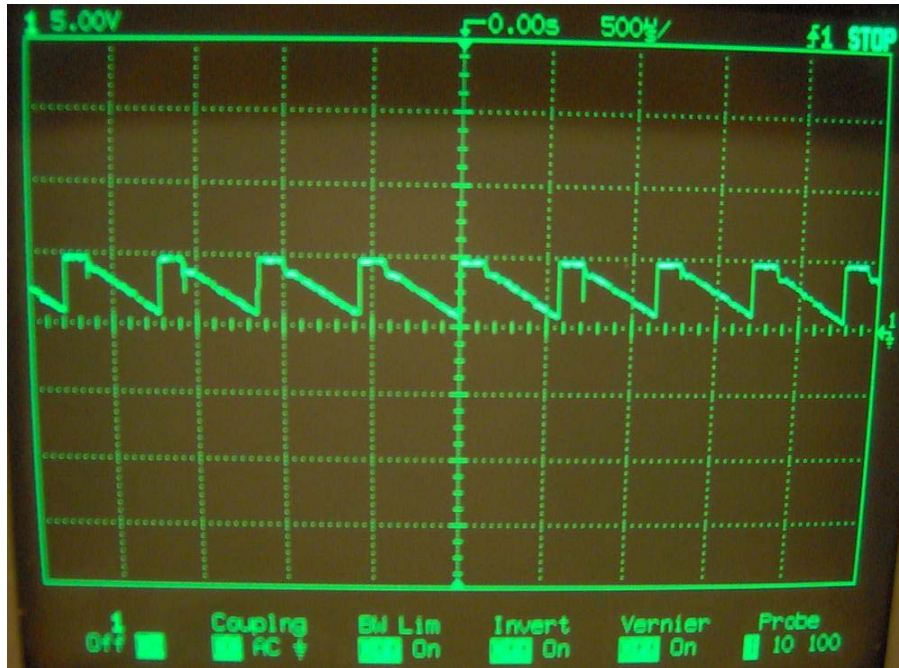

Figure 5-8 Integrator Output

As predicted, the integrator integrates downward until it is reset to 5V by the PMOS. Although the output of the multiplier was not ideal, it still had an amplitude linearly proportional to the audio signal, so the integration should still work in theory. When the reset switch opens, returning the integrator to normal mode, there is a voltage spike observed. This should not affect the dsPIC's reading however, since it only samples right before the reset switch is activated. There is a potential issue in that the integrator seems to jump to some voltage that is not 5V right before it starts integrating. This may be due to the capacitor not fully charging to 5V. This was an issue that time did not permit us to fully investigate.

5.4 Digital Signal Processing

In this section we will illustrate how the dsPIC performed its functions when the circuit was actually implemented. We will examine the functionality of the dsPIC step by step and explain any differences between actual and ideal behavior. First we will look at how the performance of the clocks and the reset switch. Then we will look in depth on how the pulse width modulation performed.

5.4.1 Clock

The clock signals are shown below in the figure below. It can be seen that they are out of phase with each other to allow for proper multiplication and modulation functionality in the rest of the circuit. The final modulation frequency that we achieved was 100Khz.

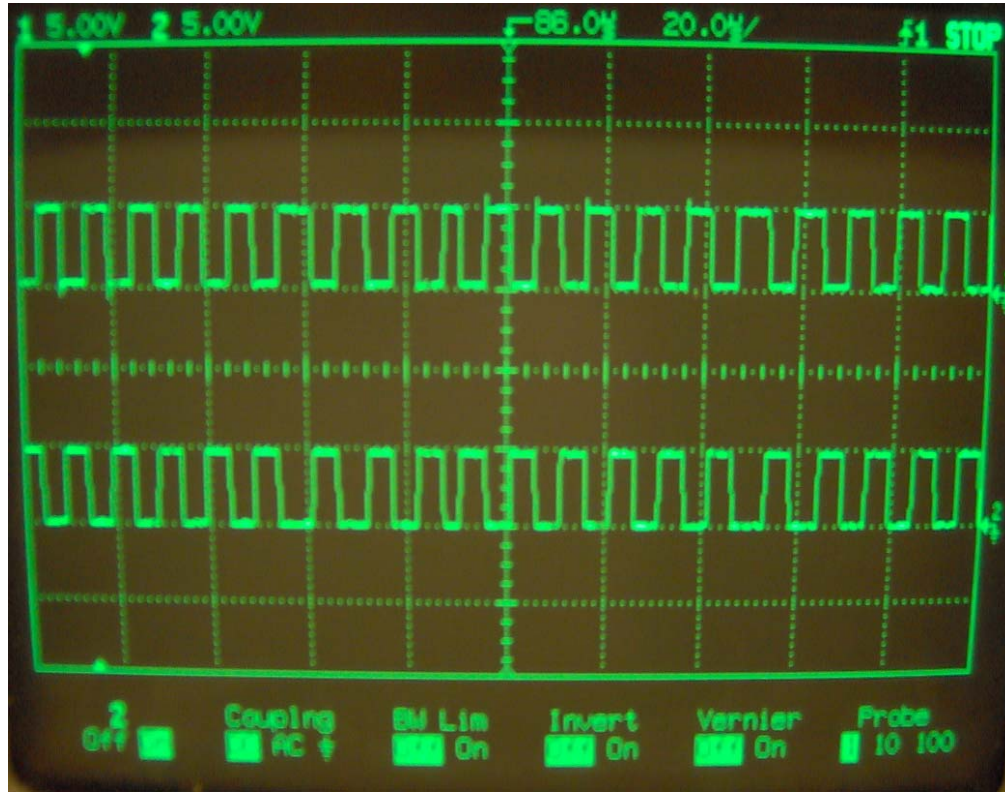

Figure 5-9 Inverted and Non-Inverted Clock Outputs

Normally when the ADC interrupt is called the clock continues to be modulated with a slower square wave during the delay times. In figure: shown below we have taken out the modulation so that we could trigger the wave form and shown the length of the interrupt is roughly $\frac{1}{4}$ of the total period. This is because the interrupt doubles as a PWM pulse.

The sampling frequency of our system can also be derived from figure: below. The time between when the ADC interrupt is called is the period and it is roughly 550 microseconds, which translates into a 2000Hz sampling frequency.

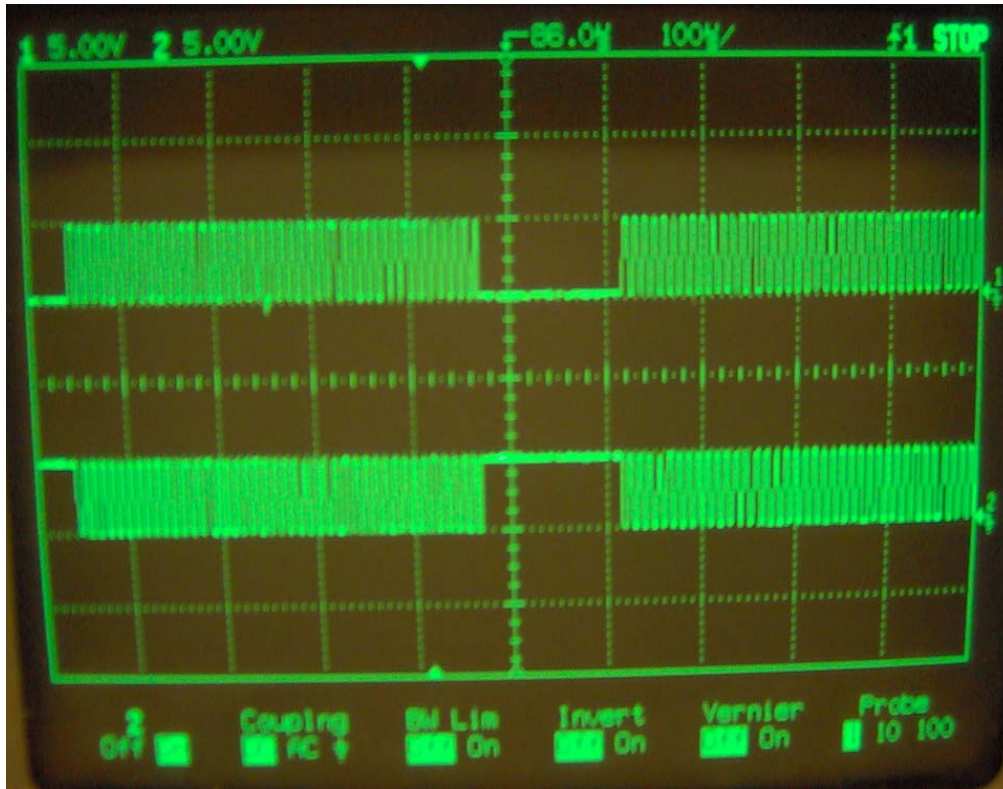

Figure 5-10 Clock Outputs with Interrupt

Our implementation was meant to have a 4000KHz sampling rate to account for the human hearing range. We turned down the frequency for our final demonstration because we were only trying to detect 60Hz which does not need such a high sampling rate. Also the amount of square wave integrations doubled so we could get a more accurate signal. The sampling frequency can be turned back up to 4000KHz by sampling changing a configuration bit.

5.4.2 Reset Signal

The waveform for the reset signal is shown in the figure below. The reset signal was high to keep the MOSFET as an open circuit while the capacitor in the integrator charged. When the ADC interrupt is called the integral has been sampled and converted to a quantized number. If you look at periods of the signals in figure: above and figure: below you can see that the reset of the integral takes place during the ADC interrupt.

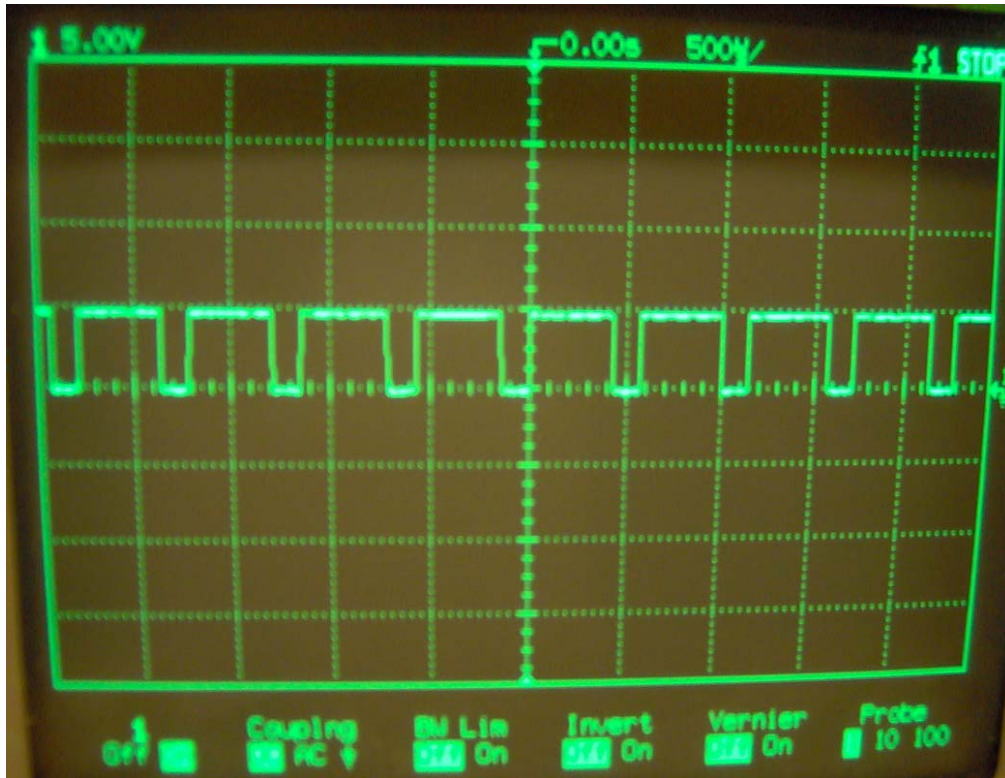

Figure 5-11 Vreset Waveform

While the ADC interrupt is computing the new PWM duty cycles the capacitor is discharging. When the ADC interrupt finishes the reset signal is set high again and the capacitor charges.

5.4.3 Pulse Width Modulation

The pulse width modulation module performed well. Figure: shown below is an input test signal at 300Hz from a function generator and the resulting output waveform of the PWM. The PWM behaves as it should; the pulses get longer when the input sinusoid is higher in amplitude.

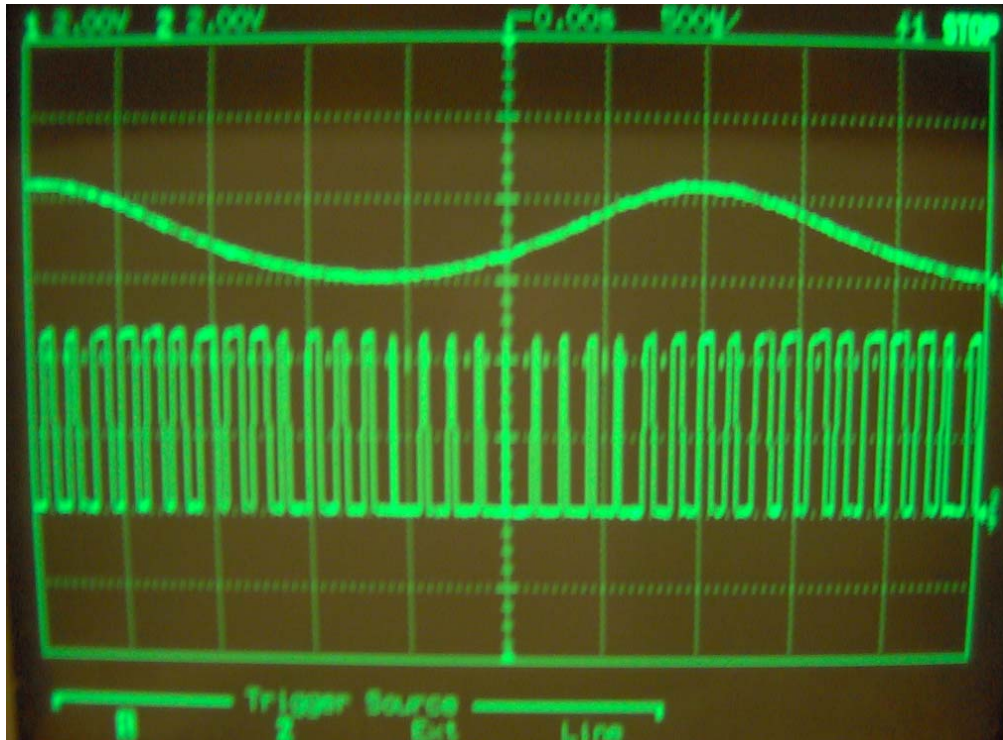

Figure 5-12 Output of PWM with Sinusoidal Input

The only discrepancy between the observed PWM output and ideal is that the PWM wave form is delayed. The reason for this delay lies in the nature of the PWM code. The value read into the ADC is not actually implemented until one cycle after it is read. A small delay in listening to an audio signal would not be perceptible to a user, and is therefore perfectly acceptable.

Another behavior to note is that because we had to half the sampling frequency to 2000Hz down from 4000Hz the frequency of the PWM when from 16 KHz down to 8 KHz.

5.4.4 Reconstruction Filter

The reconstruction filter is designed to filter out the high frequency PWM pulses and leave the low frequency information that is related to the width of the pulses. Ideally the PWM frequency would be out of the range of human hearing but because we had to lower the clock frequency the PWM frequency became very audible to the human ear.

Figure: illustrates the PWM waveform from the 300Hz test signal and the resulting waveform after the low pass filter. The PWM pulses line up better with this

waveform then with the input because there is less of a delay. There still is some delay that is associated with phase delays in the low pass filter.

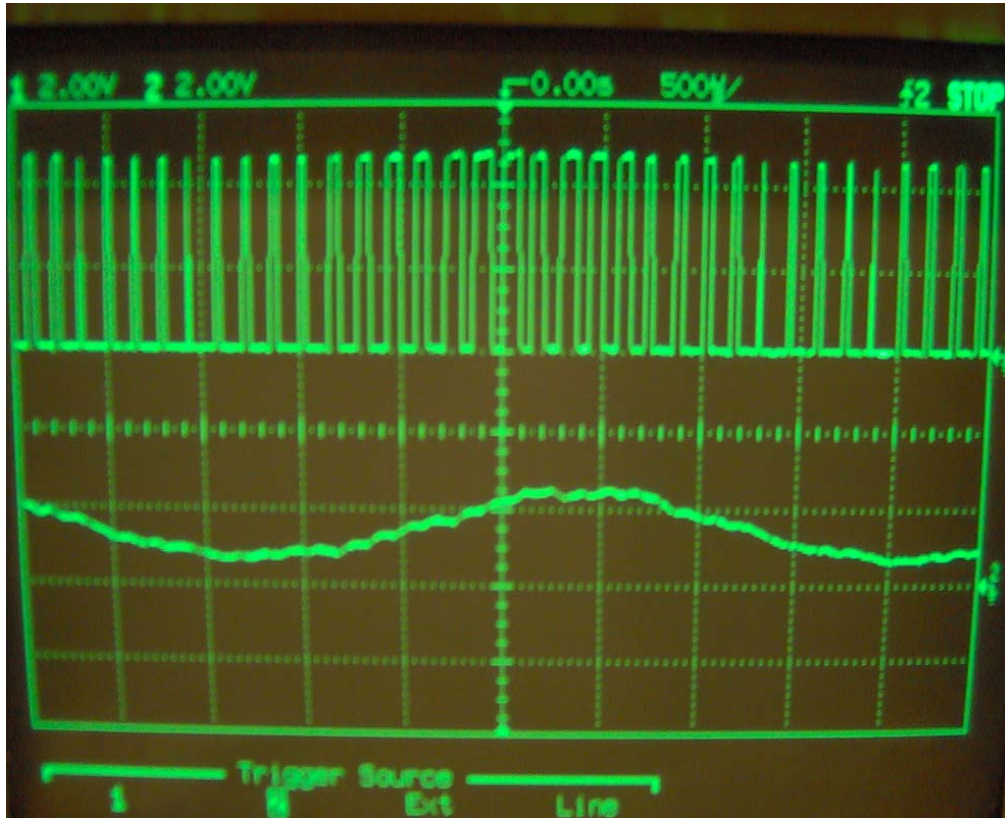

Figure 5-13 PWM Output and Reconstructed Signal

The output waveform is also very choppy. This behavior is due the fact that the PWM frequency is so low that some of it still ends of in the output of the low pass filter. If you were to zoom in you could see faint remnants of the 8000Hz PWM pulses.

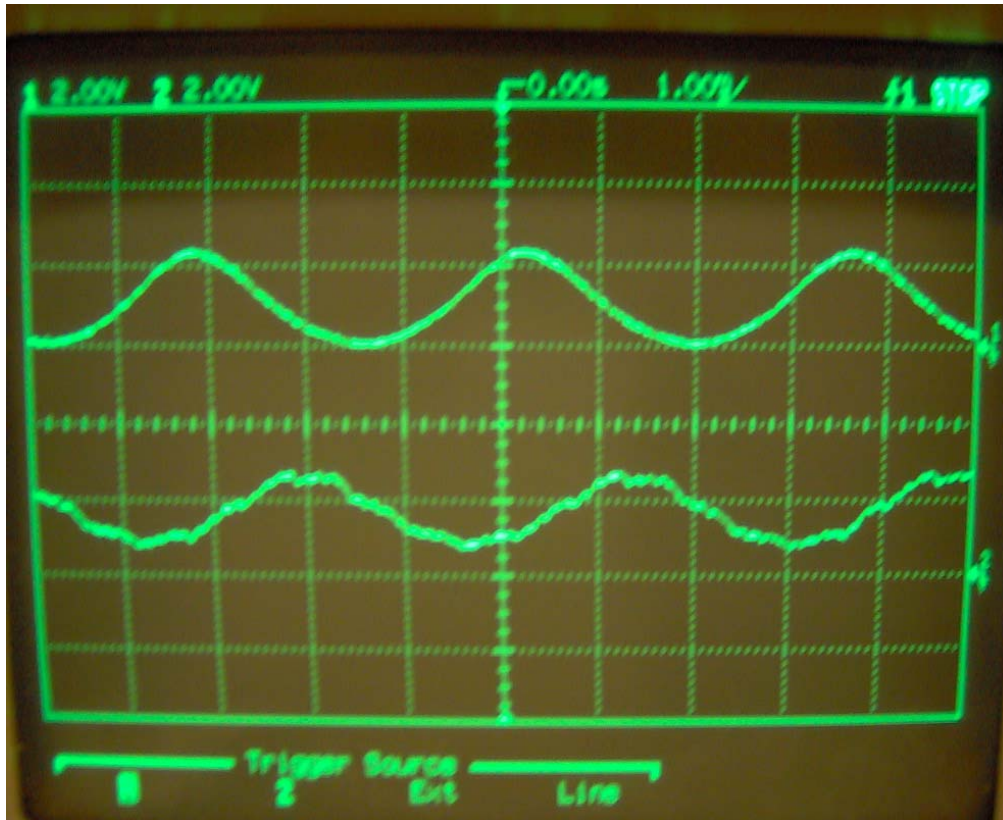

Figure 5-14 Input Waveform and Reconstructed Signal

The figure shown above is the input waveform from the function generator above, and the output waveform of the PWM passed through the low pass filter. The major differences to note are the delay caused by the nature of the ADC interrupt, and the choppiness caused by a low PWM frequency

5.5 Total System Performance

When we tested our final system we had to alter a few things from our original implementation to get it to work. We had to lower the sampling frequency which involved changing a few configuration bits. We also needed change the alignment of the laser so that the main reflected beam was hitting the center of the Fresnel lens.

The setup for the final test is shown in the figure below. The detector, window, and speaker were all mounted on separate tables to make sure no vibration coupled through the platforms.



Figure 5-15 Total System Setup

Our system was powered from the lab power supply .We used a function generator to drive an amplified subwoofer. We swept through several low frequencies and found that the window hit resonance around 60Hz. When the window hit resonance we could successfully read a 60Hz sinusoid from the window.

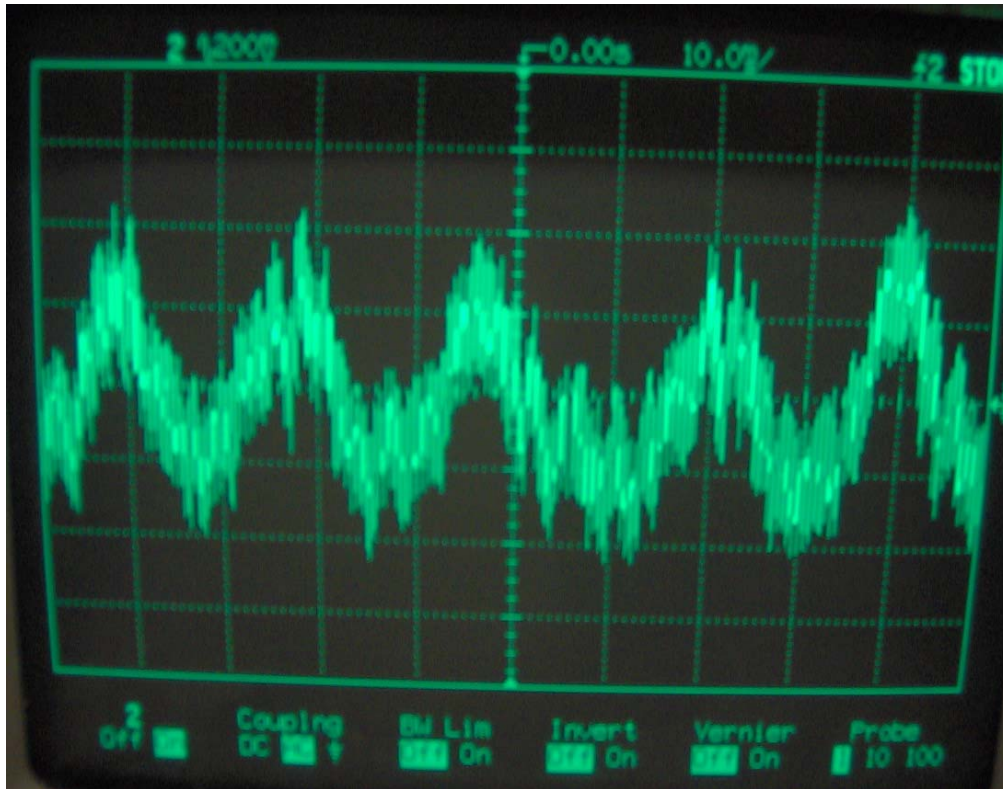

Figure 5-16 Reconstructed Audio Signal

The figure shown above is the scope reading we had on the output of the low pass filter. As we changed the frequency around 60Hz the sinusoid would sharply drop off. The 60Hz sinusoid was present only when the window was being vibrated. It was not caused by 60Hz noise present in the electrical system.

Unfortunately we were not able to detect audio information using backscatter from the window. The time allotted to us for this project did not allow us to perfect our system as much as we had hoped, and ultimately we fell short of our major goal. We were able to detect whether or not backscatter was present. This manifested itself by the output peaks of the integrator waveform shifting up and down small amounts based on whether or not backscatter was present.

6 Conclusions and Recommendations

As discussed, our system did not reach the level of functionality that we desired. Most importantly, we failed to achieve our objective of recovering an audio signal from the backscatter of a laser beam incident on a window. In this section we will discuss what our results mean in terms of the degree of success of our project, and whether what we have accomplished has worth. Also, we will discuss each module of our system and how it could be improved by another design phase.

6.1 General Conclusions

Although we were unable to retrieve an audio signal from backscatter, we were able to retrieve an audio signal when the reflected beam was incident on the Fresnel lens. This does prove the overall functionality of the system, albeit with a larger amount of light input than desired. This shows that the overall logic of the system was correct in that it could convert a light input, modulated at high frequency square wave and modulated by an audio signal by the window, back into an audio signal. We also showed how this technique could be used in conjunction with filtering to remove any undesired light from the system.

We also showed that it was possible to detect very small levels of light with our system. When observing the performance of our system using backscatter we were able to observe whether or not backscatter was present, although we were unable to extract audio information from it since it was so small. We were able to observe this effect at the output of our integrator as the average height of the peaks changed with whether or not backscatter was present. Such an observation was not possible at earlier stages in the circuit since the detected signal was so small. This proves that the correlation technique that we used did indeed give us better resolution to observe these small levels of light. If we were able to increase our modulation frequency higher and obtain more pulses cycles per integration period our resolution should improve significantly to the point where audio can be detected using backscatter.

6.2 Recommendations for Specific Modules

In order to improve the overall performance of the system, the individual components need to undergo further investigation and be improved upon. We will now summarize the limitations of each system module that inhibited system performance and how we recommend that it be improved.

The laser diode driver circuit, as discussed in the previous chapter, seemed to function as desired. It was not however, for reasons discussed in the Implementation chapter, a very robust solution for a final device. Rather, it was a circuit that was designed to be easy to implement and functional for our testing. In a further design phase of this project, we would recommend that other laser diode driver circuits be investigated. Pre-manufactured ICs that are designed to drive laser diodes may be the best solution, provided they can be used to modulate as desired. Another option to look into is driving the laser diode in constant power mode, which entails using a control system and the laser diode's built-in photodiode to ensure a constant power output. Ideally a constant current will drive a laser with a constant power out, but there can be small fluctuations. Since the consistency of the laser amplitude is one of the basic assumptions of our system, adding this measure to ensure it is stable would be desirable.

The detection stage of our circuit was the main limiting factor in terms of limiting the operating frequency of the device. The RC rise time of the output of this stage was very limiting. We added a capacitance to the feedback loop of the transimpedance amplifier to reduce ringing noise that introduced this behavior. It is possible that a smaller capacitance could improve this. Also it is possible that there is a superior op-amp for this application than the AD818 that we chose. Reducing the resistance in the feedback loop could improve the rise time but one must be able to accept the reduction in signal size that occurs from this.

The clamper circuit that we used also seemed to have some issues as well. In hindsight, it is possible that this circuit element should have been eliminated. Its purpose was to increase the area to be integrated later on by clamping the bottom of the signal to ground. Unfortunately, we also observed that since the noise was clamped to ground as well, instead of the noise being centered on ground and canceling itself out in the integration it added a significant positive contribution. The result of this integration was a

constant, which does not effect the quality of the result (DC is filtered), but it does reduce the dynamic range that remains for the output of the integrator to work with.

If the clamper was eliminated, then the multiplier circuit would likely need to be redesigned to support input voltages that were both positive and negative. The simplest solution may be to use an analog multiplexer IC rather than designing one, although this could be done using more MOSFETs.

The integrator seemed to work properly other than the non-ideality we observed with the reset operation. It appeared that the integrator may not have been reset to exactly 5V every time. Further investigation into this area would be necessary. One possible cause of this problem is insufficient time allotted to discharge the capacitor. Another issue that we had in this stage of the circuit was the fact that since the dsPIC's ADC drew more current than expected we needed to add a transistor for current gain. We never determined why the dsPIC drew so much current, as ideally an ADC input would have high impedance.

Making the dsPIC code more dynamic would be a big improvement. Global variables at the start of the program to allow easy adjustment of the sampling frequency and the PWM frequency would be an advantage. Doing this would mean that you would have to put in safeguards to guard against overflow and underflow.

Try to use nested interrupts to dynamically adjust the pulse high and low of the interrupt instead of using software delays. It would probably require the use of 2 more timers one that kept the program in the ADC interrupt until it times out, and other that would keep it high until it runs out then set it low.

It would be even better if the two PWM timers could be used to interrupt the ADC interrupt and switch the timer high or low. Then you may even be able to have the ADC interrupt perform floating point division to mitigate the quantization error that occurs from right shifting the bits. The PWM interrupts could return to the ADC interrupt instead of to square wave while ADC interrupt was in the middle of performing calculations.

Another consideration that could possibly reduce quantization error is to dynamically adjust the voltage references. Such an algorithm might keep track of the

general range of the input signal over the last few seconds and adjust the references accordingly.

Digital filtering is also a possible area for expansion. You would have to keep track of past inputs in buffers for FIR filtering, and outputs as well for IIR filtering. The order of the filter may be a concern for the dsPIC which does not have a lot of memory. IIR has less memory requirements but more computation requirement than an FIR. An FIR filter also can have linear phase delay built which is desirable for audio applications. You could even take it a step further and use an adaptive filter to find the transfer function of the window and suppress the extra noise due to window resonance at certain frequencies.

The output stage is definitely an area of the project that needs to be improved. We got as far as the filtering stage so we could see the output on a scope. An obvious addition to the system would be an audio driver stage. The low pass reconstruction filter needs to be redesigned for more suppression at the PWM frequency. The PWM frequency should be raised so that it is out of the range of human hearing.

Another consideration is that the system's performance may be improved by implementing the circuit on a PCB board rather than a breadboard, which is more susceptible to noise.

6.3 General Recommendations

The main limitations that we had in completing this project were manpower and time. We were constrained to the fact that we had only two people and two terms to complete this project. Other limitations included our budget and personal knowledge. It is now clear that the project goals we defined at the beginning of this project were harder to reach than we anticipated. The limitations we had upon us prevented us from reaching our main goal, which was to create a laser audio surveillance device that was fully functional and could detect audio using only backscatter. While we made great progress towards this goal, ultimately we did not get as far as we had hoped. It is for this reason, that we strongly believe that another design phase on this project is in order, and recommend to our advisor that a subsequent Major Qualifying Project be performed to enhance our design.

The research and design that we have completed should give a subsequent group good starting point for creating a functional device. Based upon what we have experienced, we recommend that candidates be selected for this subsequent project with expertise in the following areas: analog microelectronics, PIC programming, RF and antenna issues, and optics. In terms of manpower, it may be desirable to expand this to a three person project, with two Electrical and Computer Engineering students and one Physics student to concentrate on the optics. This is something that may not be necessary but we recommend that our advisor consider.

In conclusion, we feel that despite the performance of the system that we created being not as well as we had hoped, we do believe that we have made significant contributions to the task of solving the problem at hand. This progress could be put to good use by a subsequent project group. We learned a great deal about various disciplines of electrical engineering and even physics during this project; both theory and practice. We have a great sense of accomplishment from this project and agree that it has been an appropriate culmination to our undergraduate Electrical and Computer Engineering education at Worcester Polytechnic Institute.

7 Appendices

7.1 Components List

Specialty Components

Quantity	Description	Value	Supplier	Cost	Part No.
1	Laser Diode	7mW 650nm	Thor Labs	\$10.64	DL3147-060
1	Fresnel Lens	11"x11"	Edmund Optics	\$85.00	NT32-691
1	Photodiode		Advanced Photonix	\$2.19	PDB-C134
1	Microcontroller	40-DIP	Microchip	\$14.53	dsPIC30F4013
1	Op-Amp		Analog Devices	\$4.01	AD818
			National		
1	Op-Amp		Semiconductor	\$2.10	LF357
			National		
1	Op-Amp		Semiconductor	\$0.84	LM741

General Components

Quantity	Description	Value
2	Battery	9V
1	Regulator	5V
1	MOSFET IC	N/A
1	PMOS	N/A
2	NPN Transistor	N/A
2	Diode	0.7V Drop
1	Zener Diode	2.6V
1	Zener Diode	5.1V
1	Potentiometer	10 Kohm
1	Resistor	51 Ohm
1	Resistor	75 Ohm
1	Resistor	300 Ohm
3	Resistor	750 Ohm
4	Resistor	1 Kohm
2	Resistor	1.5 Kohm
1	Resistor	2 Kohm
3	Resistor	10 Kohm
1	Resistor	200 Kohm
3	Capacitor	10pF
1	Capacitor	0.001uF
2	Capacitor	0.01uF
3	Capacitor	0.1uF

7.2 Full Circuit Schematic

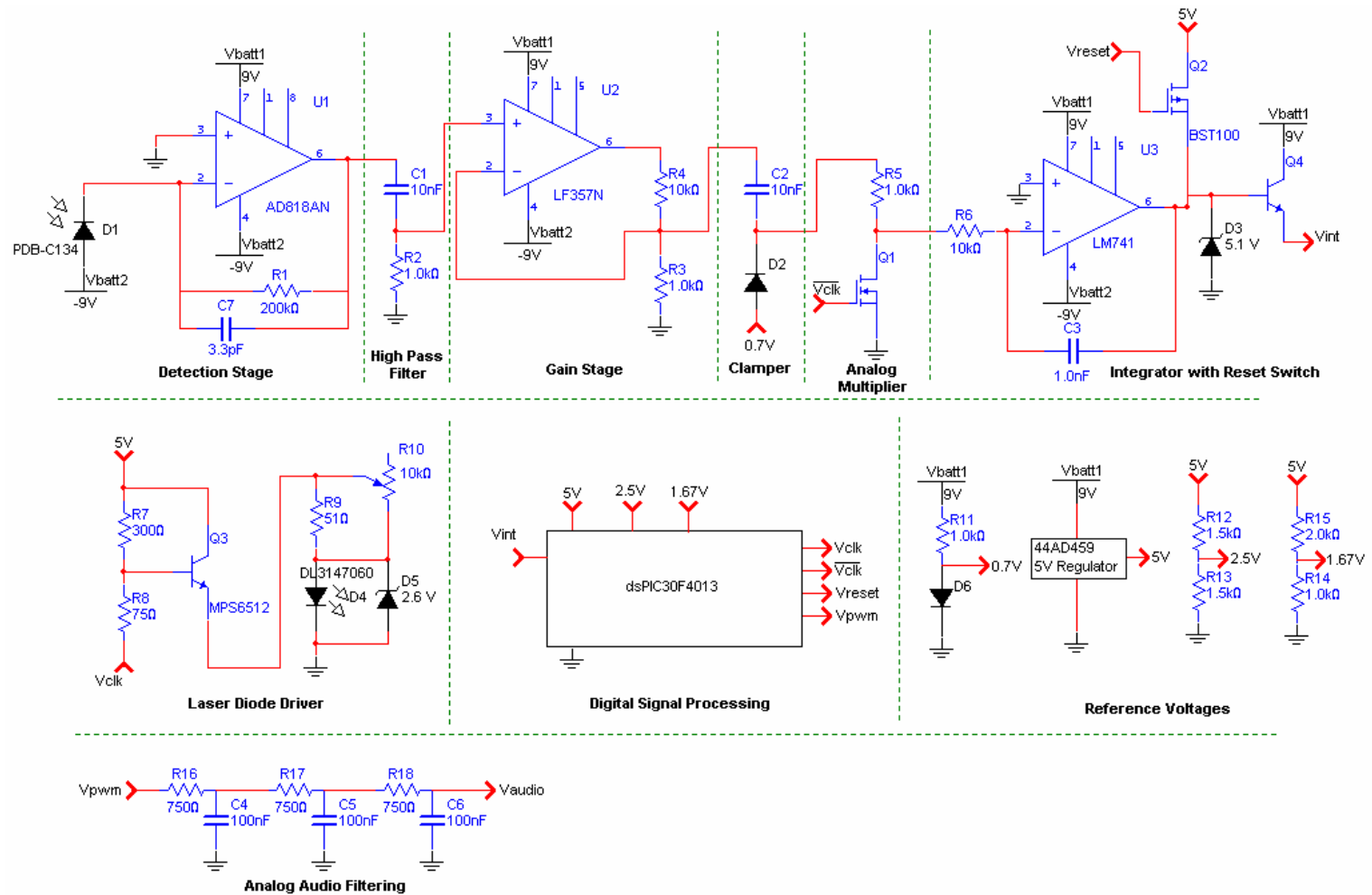

Figure 7-1 Full Circuit Schematic

7.3 dsPIC Code

```
#include "p30f4013.h"           //support for the dsPIC

extern void square_wave(void);   //assembly language squarewave
int main(void) // begin
{

ADC_Init(); //initialize the ADC
TRISC=0;    //set PORTC to all outputs
TRISD=0;    //set PORTD to all outputs
TRISF=0;    //set PORTF to all outputs
PORTF=47;   // initialize PORTF
PORTD=2;    //sets the reset signal to high meaning no reset

while(1)    //infinite loop
{

    square_wave();    //call the assembly language squarewave
function

} // while loop
} // end main
```

```
#include "p30f4013.h"

        .text

        .global _square_wave
_square_wave:

main:

nop      ;actually 36 nop on either side but it would not fit
nop      ;in report that way
nop
NEG PORTF
nop
nop
nop

goto main

return
.end
```



```

#include "p30f4013.h" // support for dsPIC
/*Declarations*/

int i=0; // index
volatile unsigned int * iPtr; //pointer for ADC

/*Dynamic Interupt Adjust Variables*/
int high_time=0;
int low_time=0;
int delay=0;

/*Smooth Adjust Variables*/
int past = 0;
int present = 0;
int smooth = 0;

//Prototypes

void ADC_Init(void);
void __attribute__((__interrupt__)) _ADCInterrupt(void);

void ADC_Init(void)
{
// Configure Analog Pins

    TRISB = 1; // sets 1st pin in PORTB(AN0) to an input
    ADPCFG = 0xFFFF; /*sets AN2 to an analog input,
                       the rest are digital I/O*/

// Selecting Input to S/H Channels

    ADCHS = 2; // 0 set AN0 as input to CH0
                // CH0+ input is AN2.
                // CH0- input is VREFL (AVss)
    ADCSSL = 0; // no inputs are scanned

// Set PWM Frequency

    TMR1 = 0x0000; // timer 1 default settings
    PR1 = 2105; // PWM period
    T1CON = 0x8000; // turn on timer 1

// Set PWM Duty Cycle Timer

    TMR2 = 0x0000; // timer 2 default settings
    PR2 = 0x000; // Duty Cycle
    T2CON = 0x8000; // turn on timer 2

// Select ADC Conversion Clock

    TMR3 = 0x0000; // timer 3 default settings
    PR3 = 8192; // Sampling Period
    T3CON = 0x8000; // turn on timer 3

```

```

// Select ADC Conversion Trigger

    ADCON1bits.ADSIDL = 0; // continue operation in idle mode
    ADCON1bits.FORM = 0; // sets output of ADC as int
    ADCON1bits.SSRC = 2; // timer 3 is sample/convert trigger
    ADCON1bits.ASAM = 1; // sample once convert is done
    ADCON2bits.VCFG = 3; // AVdd and AVss are voltage
    ADCON2bits.CSCNA = 0; // Do not scan input selections
    ADCON2bits.SMPI = 0; // 1 sample per interrupt
    ADCON2bits.BUFM = 0; // 16 word buffers
    ADCON2bits.ALTS = 0; // Use A inputs for multiplexing
    ADCON3bits.ADRC = 0; // sets clock as system derived
    ADCON3bits.ADCS = 32; // adc conversion clock select bit

// turn ADC on

    ADCON1bits.ADON = 1;

// Enable Interrupts

    IFS0bits.ADIF = 0; // clear conversion interrupt
    IEC0bits.ADIE = 1; // enable ADC interrupt
    IFS0bits.T3IF = 0; // clear timer 3 interrupt
    IEC0bits.T3IE = 0; // enable timer 3 interrupt
    IFS0bits.T2IF = 0; // clear timer 2 interrupt
    IEC0bits.T2IE = 1; // enable timer 2 interrupt
    IFS0bits.T1IF = 0; // clear timer 1 interrupt
    IEC0bits.T1IE = 1; // enable timer 1 interrupt

    return;
}

```

```

void __attribute__((__interrupt__)) _ADCInterrupt(void)
{
    PR2 += smooth;           // 4th addition of the smooth factor
    PORTC = 0x2FFF;         // set PWM high
    PORTF=47;               // inverted clock high
    TMR3 = 0;               // resets Timer 3
    IFS0bits.T3IF = 0;     // clear interrupt flag
    PORTD = 0;              // begin reset signal
    past = present;        // save last pulse width
    iPtr = &ADCBUF0;       // set pointer to ADCBUF0
    present = (*iPtr>>1);  // load new duty cycle into PWM

    smooth = (present-past)>>2; //calculate new smooth factor

    /* to accommodate delays from branching executing
    instructions the floor value is 36 but we still
    need to represent the values between 1 and 36*/

    if(PR2<36){PR2+=36;}

    /* past values for pwm high time are between 36
    and 2048 this scales down the high time to a max of 256*/

    high_time = past>>3;
    low_time = 256-high_time;

    /* this for loop is timed up to last as long as the next
    pulse's high time would if there were no interrupt
    wasting time is avoided by making continuing to modulate port F */
    for(i=0; i<high_time; i++){
        PORTF=-PORTF;}

    PORTC = 0; // set PWM low after appropriate delay

    /* this delay makes the Interrupt last as long
    as any of other PWM high/low periods*/

    for(i=0; i<low_time; i++){
        PORTF=-PORTF;} // modulate port F
    PORTD=2; // end reset signal
    IEC0bits.ADIE = 1; // enable ADC interrupt
    IFS0bits.ADIF = 0; // Clear the A/D Interrupt flag
    TMR1=TMR3+4; // sync up timers

    delay=1; // delays for timing
    delay=1;
    delay++;
    PORTC=0x2FFF; // set PWM high
}

```

```

void __attribute__((__interrupt__, __shadow__)) _T2Interrupt(void)
{
    PORTC = 0;                // Set PWM Low
    IFS0bits.T2IF = 0;        //clear interrupt flag
    IEC0bits.T2IE = 0;        // disable timer 2
interrupt
}

void __attribute__((__interrupt__, __shadow__)) _T1Interrupt(void)
{
    PORTC = 0x2FFF;           // Set PWM High
    PR2 += smooth;           // increment pulse width

/* trying to sync up timer 2 and 1 time to will not
increment during this command which takes two clock periods
it also does not increment when t2 interrupt flag
is cleared so we need to add 3*/

    TMR2 = TMR1+11;

    if (PR2<36){PR2=36;}     // avoid underflow
    IFS0bits.T1IF = 0;        // clear interrupt flag
    IFS0bits.T2IF = 0;        // Clear timer 2 interrupt
    IEC0bits.T2IE = 1;        // Enable timer 2 interrupt
}

```

7.4 System Pictures

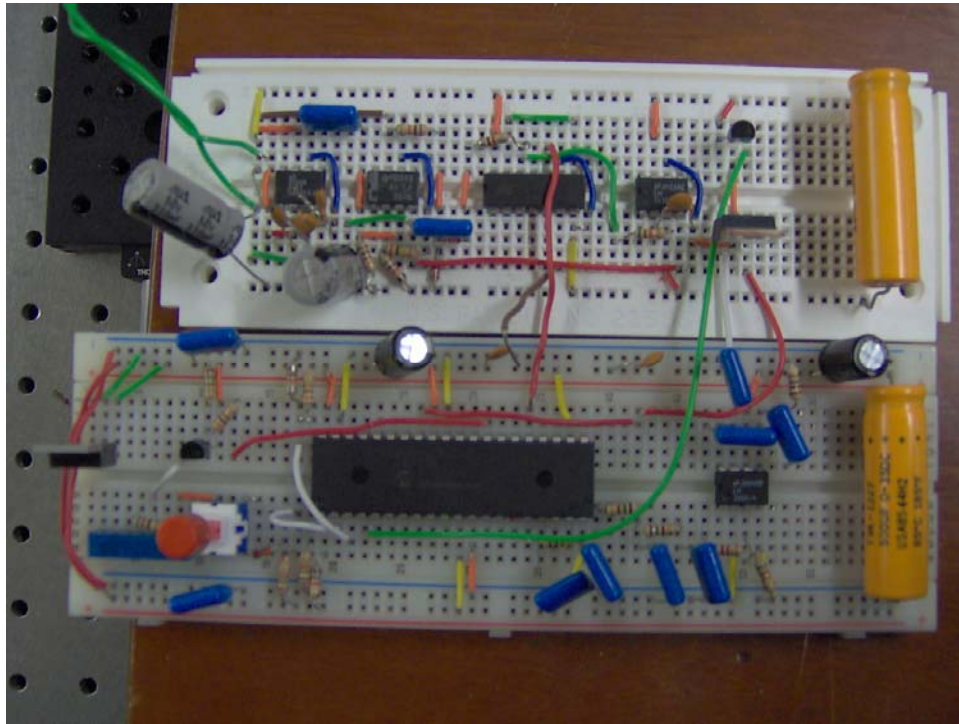

Figure 7-2 Circuit Picture

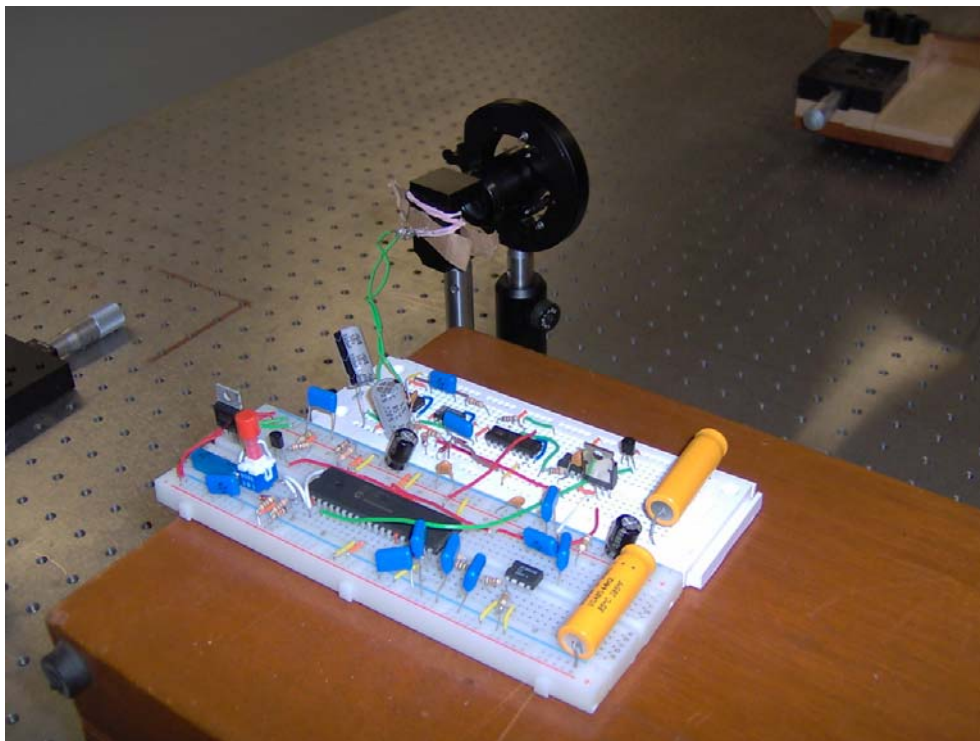

Figure 7-3 Circuit and Detector Assembly Picture

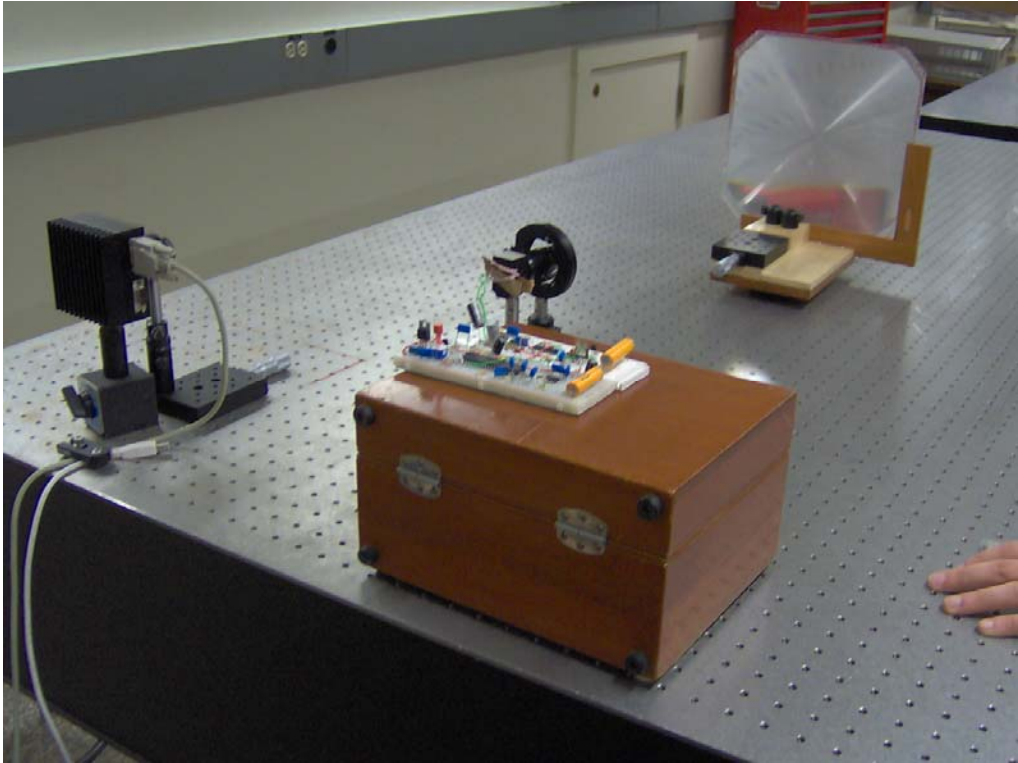

Figure 7-4 Laser Audio Surveillance Device



Figure 7-5 Device and Window

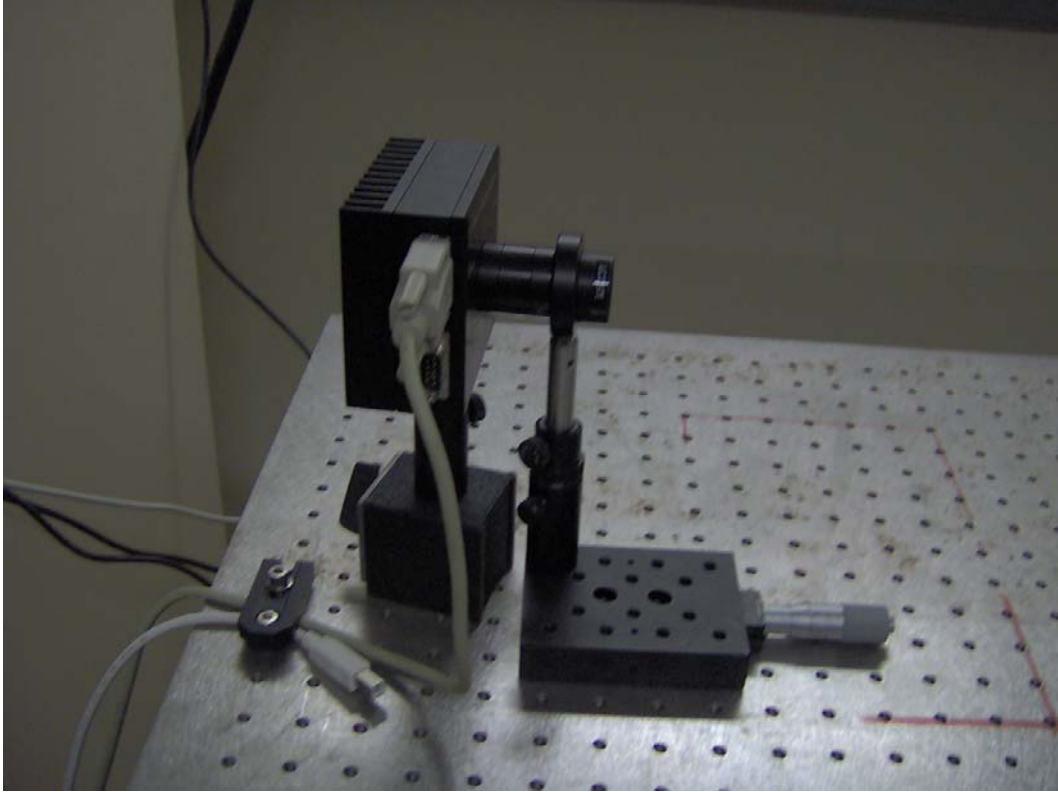

Figure 7-6 Laser Diode Mount (with Collimation Lenses)

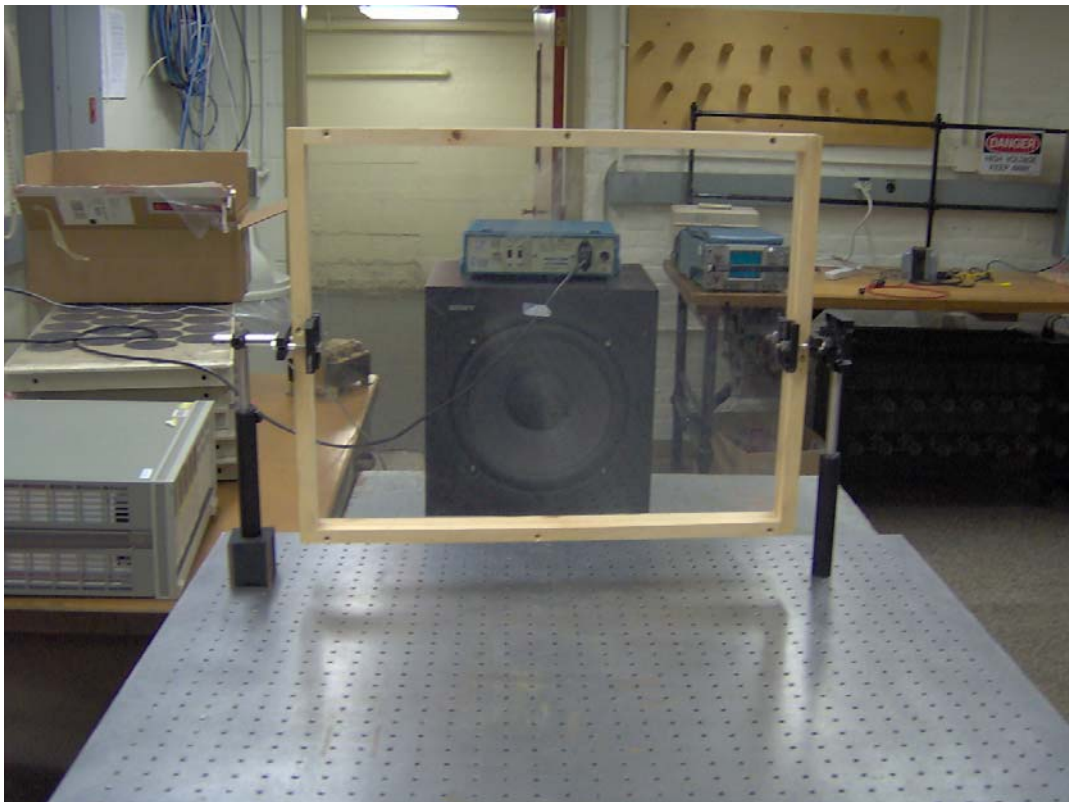

Figure 7-7 Window and Subwoofer

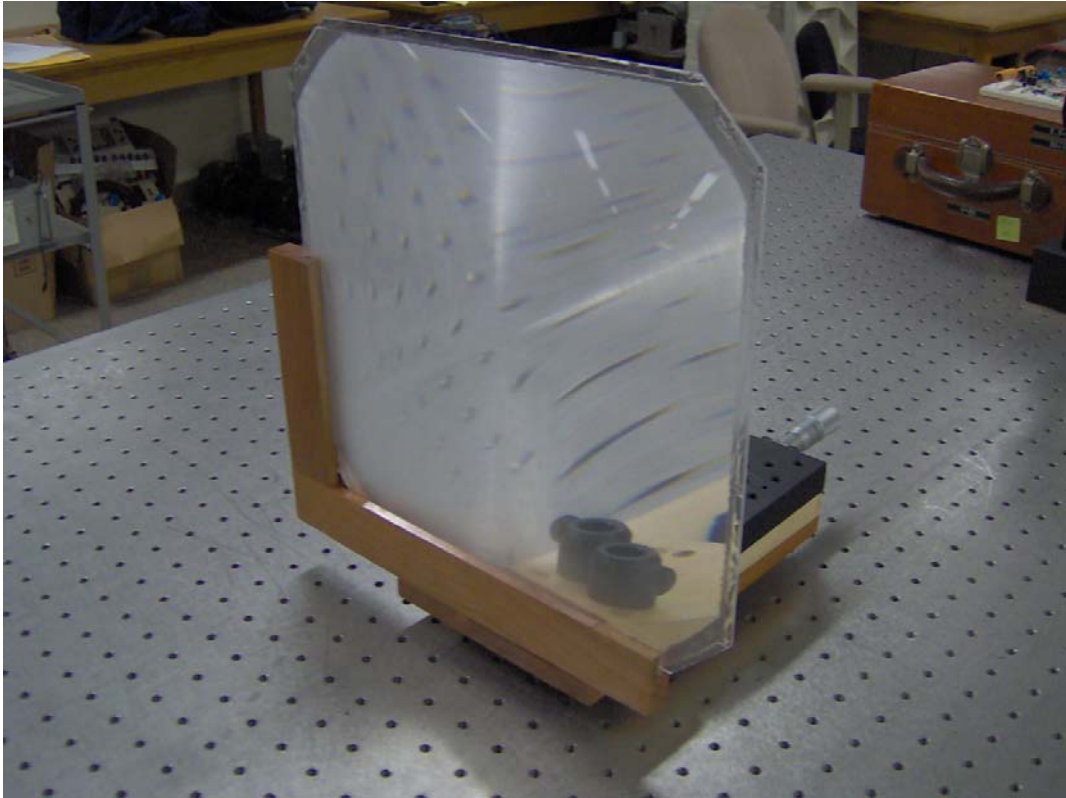

Figure 7-8 Fresnel Lens

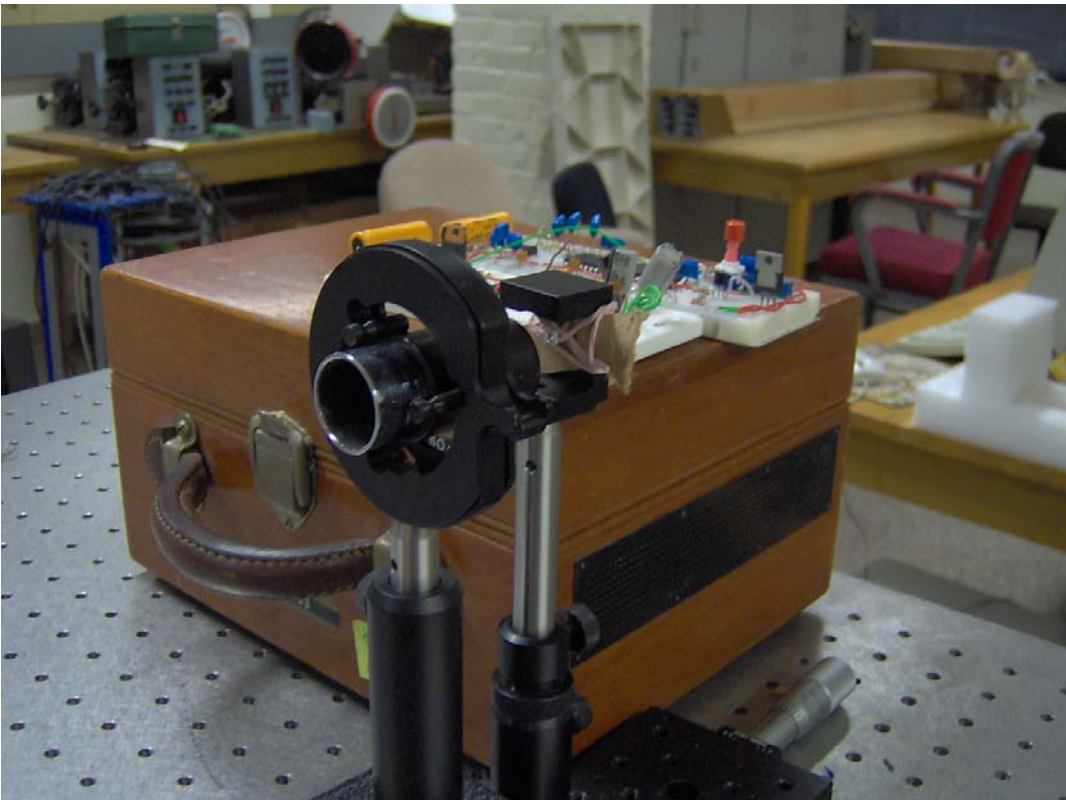

Figure 7-9 Detector Assembly and Additional Lens



Figure 7-10 Entire System

8 References

-
- [1] Le, Phong V and Cooper, Ben Laser-based Eavesdropping Device. Worcester: WPI, 2004.
- [2] Speed of Sound 2005. google.com. 20 Dec 2005
<<http://www.google.com/search?hl=en&q=speed+of+sound&btnG=Google+Search>>
- [3] Voice Frequency. 2005. Inanot.com. 20 Dec. 2005
<http://www.inanot.com/Ina-Electronics_Topics_U_-_Z-/Voice_frequency.html>.
- [4] Johnson, David A, PE. "Handbook of Optical Through the Air Communications."
Imagineeringzine.com. 2005. 20 Dec. 2005 <<http://www.imagineeringzine.com/air-bk2.html>>.
- [5] Johnson, David A, PE. "Handbook of Optical Through the Air Communications."
Imagineeringzine.com. 2005. 20 Dec. 2005 <<http://www.imagineeringzine.com/air-bk2.html>>.
- [6] Nave, C.R. Principal Focal Length. 2005. Georgia State University. 20 Dec. 2005
<<http://hyperphysics.phy-astr.gsu.edu/hbase/geoopt/foclen.html>>.
- [7] Johnson, David A, PE. "Handbook of Optical Through the Air Communications."
Imagineeringzine.com. 2005. 20 Dec. 2005 <<http://www.imagineeringzine.com/air-bk2.html>>.
- [8] Henderson, Tom. Lesson 1: Reflection and its Importance. 2004. Glenbrook High School. 20 Dec. 2005
<<http://www.glenbrook.k12.il.us/gbssci/phys/Class/refln/u1311d.htm>>.
- [9] Henderson, Tom. Lesson 1: Reflection and its Importance. 2004. Glenbrook High School. 20 Dec. 2005
<<http://www.glenbrook.k12.il.us/gbssci/phys/Class/refln/u1311d.htm>>.
- [10] Henderson, Tom. Lesson 1: Reflection and its Importance. 2004. Glenbrook High School. 20 Dec. 2005
<<http://www.glenbrook.k12.il.us/gbssci/phys/Class/refln/u1311d.htm>>.
- [11] Henderson, Tom. Lesson 1: Reflection and its Importance. 2004. Glenbrook High School. 20 Dec. 2005
<<http://www.glenbrook.k12.il.us/gbssci/phys/Class/refln/u1311d.htm>>.
- [12] Johnson, David A, PE. "Handbook of Optical Through the Air Communications."
Imagineeringzine.com. 2005. 20 Dec. 2005 <<http://www.imagineeringzine.com/air-bk2.html>>.
- [13] Johnson, David A, PE. "Handbook of Optical Through the Air Communications."
Imagineeringzine.com. 2005. 20 Dec. 2005 <<http://www.imagineeringzine.com/air-bk2.html>>.
- [14] Diode Laser Frequency Stabilization. 2005. University of Tennessee. 20 Dec. 2005
<http://electron9.phys.utk.edu/optics507/modules/m10/diode_laser_frequency_stabilizat.htm>.
- [15] Red Laser Diode DL3147-060. 2003. Sanyo. 20 Dec. 2005
<http://www.photonic-products.com/products/laserdiodes_visible/sanyo_visible_ds/dl-3147-060.pdf>.
- [16] Stanford University Laser Safety Manual. 2005. Stanford University. 20 Dec. 2005
<<http://www.stanford.edu/dept/EHS/prod/researchlab/radlaser/laser/procedures/classes.html>>.
- [17] Interferometry. 2005. Free-Definition.com. 20 Dec. 2005. <<http://www.free-definition.com/Interferometer.html>>.

-
- [18] Interferometry. 2005. Free-Definition.com. 20 Dec. 2005. < <http://www.free-definition.com/Interferometer.html>>.
- [19] Index of /physics/lab setup photos/103/img. 2005. Augustana College. 20 Dec. 2005
< <http://helios.augustana.edu/physics/lab%20setup%20photos/103/img/michelson-interferometer-2.jpg>>.
- [20] Kilpela, Ari. *Pulsed Time-Of-Flight Laser Range Finder Techniques For Fast, High Precision Measurement Applications*. Finland: Oulu University Press, 2004.
- [21] DSPIC 2005. digikey.com. 20 Dec 2005
< <http://www.digikey.com/scripts/DkSearch/dksus.dll?Filter> >.
- [22] dsPIC30F3014, dsPIC30F4013 Data Sheet. 2004. Microchip. 20 Dec. 2005
<<http://ww1.microchip.com/downloads/en/DeviceDoc/70138c.pdf>>.