

Worcester Polytechnic Institute Digital WPI

Interactive Qualifying Projects (All Years)

Interactive Qualifying Projects

April 2011

Robotics Education in the Current Industry

John Clarke Farrar

Worcester Polytechnic Institute

Jonathan Watson Noser

Worcester Polytechnic Institute

Maxwell E. Benko

Worcester Polytechnic Institute

Follow this and additional works at: <https://digitalcommons.wpi.edu/iqp-all>

Repository Citation

Farrar, J. C., Noser, J. W., & Benko, M. E. (2011). *Robotics Education in the Current Industry*. Retrieved from <https://digitalcommons.wpi.edu/iqp-all/2783>

This Unrestricted is brought to you for free and open access by the Interactive Qualifying Projects at Digital WPI. It has been accepted for inclusion in Interactive Qualifying Projects (All Years) by an authorized administrator of Digital WPI. For more information, please contact digitalwpi@wpi.edu.



Educational Robots And Their Applications

A Interdisciplinary Qualifying Project Report:
Submitted to the faculty of the
WORCESTER POLYTECHNIC INSTITUTE
In partial fulfillment of the requirements for the
Degree of Bachelor of Science By:

Jonathan Noser

John Farrar

Max Benko

In partnership with
Beijing Jiaotong University

Partners:

Date:

Approved:

Professor Yiming (Kevin) Rong
Professor Jennifer Rudolph
Professor Yao Yanan

Abstract

This project tries to identify the current robotics curriculum and robotics applications, and help advance the education of these unique machines. By first outlining the current robotics uses, we were able to determine where the industry was moving towards and how current education should be molded to accompany this change. Our pedagogical review is meant to help guide educators in forming a new curriculum based off of the success of the Nano technology fields that underwent a similar transformation.

Table of Contents

Table of Figures	Error! Bookmark not defined.
Authorship	4
Introduction	5
Methodology	7
Objective 1: Understand Relationships between Industry and Curriculum	8
Objective 2: BJTU's Educational Robots	9
Objective 3: Provide a Handbook for Teachers and Students	10
The Industry Need	10
Curriculum Research.....	18
Pedagogical Issues	21
Conclusion	27
Appendix.....	30
Works Cited	37

Table of Figures

Figure 1.....	30
Figure 2.....	31
Figure 3.....	32
Figure 4.....	33
Figure 5.....	34
Figure 6.....	35
Figure 7.....	36
Figure 8.....	36

Authorship

Introduction, Methodology, Industry need: Max Benko

Curriculum research, charts in appendix: John Farrar

Pedagogical Issues: Jonathan Noser

Introduction

Robotics is a fast growing area that is garnering much interest. Robots have been used in industry for many years, and with the advancement of technology the need for better-trained designers and technicians for these precision machines has grown. As a result, universities have been trying to incorporate robotics education into their educational programs so as to better prepare students for the technical world they will encounter. Robotics is a multi-disciplinary subject; it requires the student to learn multiple areas of study in order to fully grasp the complexities of robotics. This need to master a number of disciplines presents difficulties to students in programs designed to meet requirements for a single discipline. Moreover, new multidisciplinary fields like robotics challenge universities to create programs that provide sufficient and integrated training for students in the traditional four or five year college experience. In the current educational environment, it has been difficult for undergraduate students to successfully master robots and be prepared to enter the industries that utilize robotics.

Thus, there is a call for more students to begin learning robotics at a younger age and to start to understand the most basic concepts so that they are well prepared for the strenuous learning that will occur in a university setting. To this end, some robots are premade for use by younger students and are designed to help clearly illustrate the basic concepts of robotics and what is necessary for further study.

In our research we have found a lack of consistent products that are simple enough to be used in a primary or secondary school setting, yet complicated enough to provide a strong lesson for university students. This lack of product means that the student must learn to use a different product every time they have outgrown the previous one. Educational value of these

robots would increase by presenting a product that can be used in different ways to fulfill many different learning levels. In this way, students would be able to become very familiar with that product and truly unlock all of the lessons that it has to teach in increasing levels of complexity. Moreover, this would also allow for the student to learn about different aspects of robotics more quickly instead of relearning a lesson on a different platform before moving on to a new lesson.

In our project we located a family of robots that have the potential to fill this void. The geometry robot family that was created at Beijing Jiaotong University by Professor Yao Yanan and his group are able to provide simple illustrations as well as abstract representations of simple functions. Professor Yao Yanan is a professor working within the mechanical engineering department at Beijing Jiaotong University in Beijing China. He has led the way on many robotics projects with University graduate students. Yao Yanan has guided the way on the geometry robot project and has helped to produce over 40 different robots that are based off of the same motion principles. These geometry robots are designed to illustrate various features of geometry and kinematics. Mostly based on geometric shapes these robots bring to life the properties of geometry. From tetrahedrons to parallelograms, Yao Yanan's robots demonstrate the kinematic properties of geometric shapes. For our project we were determined to figure out where these robots would best be applied and to what degree. Starting out with background research on the market and current educational robotics market we would be able to determine some conclusions that might help us to ultimately put the geometry robots into use. Second, we fully analyzed two of the robots in this family to determine all of their mechanical and electrical features in order to determine the proper applications of these robots in the educational system.

We expected many challenges with our project due to the technology and the lack of information on a younger student setting. Our first major problem would lie in collecting data

from the American middle and high school educational systems. Robotics is not a popular subject in the pre-college setting so information was very scarce. The technology also presented challenges as we were working with an underdeveloped product that is protected by patents; this made collecting information difficult. Other problems came with the general environment in which the project was taking place; the bicultural nature of our team meant that communication between the American and Chinese students was at times very challenging, making it hard to transfer information from either side without something being lost in the translation.

After overcoming most of these challenges we were able to collect sufficient data on the desired item. At times, we had to make a few compromises towards what we were researching. By reviewing all of our background research we were aiming to provide a promotional manual for the selected robot and provide a basic knowledge of how the robot could be applied to various classroom settings. We also wanted to provide some suggestions to the creators of the robots as to where the robots would best be applied in the educational system. This also allowed us to provide teachers and school administrators with information on how the robot should be applied and what it would best teach to its students at that age level.

Methodology

The main goal of our project is to understand the current and future robotics industry needs, current robotics curriculum, and analyze the gap that might occur between the two. To better understand this goal we devised more specific goals based on educational geometry robots created at Beijing Jiaotong University. This goal was to determine a market and use for two

selected geometry robots, among 42, that were created by Professor Yao Yanan and his group at Beijing Jiaotong University. To accomplish this, our team devised three main objectives.

Objective 1: Understand Relationships between Industry and Curriculum

To accomplish this objective we needed to understand the importance of robotics education in engineering curricula throughout China and the United States. To understand these subjects in both China and the United States we had our group members research the topics for their respective countries. We broke this topic down into studying robotics technology and industries, robotics curriculum, and how educators have approached these issues before. Studying robotics technology was broken down further into industrial and educational robots. When deciding what to focus our research on we looked into the overall distribution of robots in all applications. We found that over 90% of all robotics applications were industrial. This fact alone guided our focus into the industrial robotics industry. When we looked further into industrial robotics we decided to focus on the most prominent industrial uses. Robotic engineers were most likely to be working with these robots due to the vast numbers of robots that are applied in these settings and so focusing our research on the most important applications was our major deciding factor. Robotics curriculum was broken down into Chinese and United States university curriculum. Finally when studying how educators approached these issues, we researched these various topics in order to expand our knowledge of the growth of robotics. We learned how manufacturing plants are beginning to use more and more complex robots as their specifications for use increase. Students who graduate from universities with a specialization in robotics are generally underprepared for the responsibilities their future employers will challenge them with because the field is advancing so quickly. We found that educators can relate the

growth and development of the field to that of nanotechnology, a field that experienced similar alterations to robotics years before. These topics would allow understanding the big pictures for robotics education and industry.

Objective 2: BJTU's Educational Robots

Evaluate the functions, uses, and structure of the educational robots created by Beijing Jiaotong University. First we had to select two of the 42 robots created at Beijing Jiaotong University. To whittle the number of robots down to a usable number for the project, we examined each of the 42 robots and classified them based on their motion principles. We determined that the easiest to document would be a simple form of a 4 bar linkage, so we disregarded any with advanced movement techniques, such as “horse-leg” simulators or those with treads. From the remaining robots, many had multiple bar linkages, so we eliminated those with more than 4 bars. This left us with two remaining robots: the walking 4 bar linkage robot, and the rolling parallelogram robot. We chose these robots of the 42 robots because they demonstrated educational topics in the simplest fashion. The first robot selected was a rolling parallelogram. The next was a walking four bar linkage. . Given that these robots would be intended for both university and middle school setting, we decided that the geometry involved should be as simple as possible. Of the many variations of geometry robots these two robots were the simplest forms of the concepts shared 42 geometry robots. From our initial evaluation these robots seemed the most easily adapted for classroom use. The next step was to research these robots, evaluate what functions they can perform, and study how they are constructed in order to better understand how they would be useful in a classroom setting. In order to do this we needed to collect information about two of the specific robot families created by Prof. Yao Yanan, determine the basic kinematic principles behind the robots motion, classify the robots

into general classes that help to quickly identify their shape and functions, evaluate what educational functions this robot can perform, build two of the robots created by Prof. Yao Yanan's group in order to reverse engineer their functions, evaluate the motor conditions and construction process, and keep detailed description of how to assemble these robots for use in the handbook

Objective 3: Provide a Handbook for Teachers and Students

Based on our results from objective two we created a handbook for the parallelogram robot that was selected. This handbook outlined the different educational applications that the robot has at different levels of education. Some of the basic information about the robot in general is provided in order to let possible users further understand the functions and features that the robot contains.

The Industry Need

To understand the importance of robotics education we needed to understand robotics role in the industry. This role will help determine the importance and needs for robotic education. Research into the industrial robotics market provided us with a clear understanding of what skills the market requires for employees to be successful. While there are many possible robotics applications, the job market is dominated by five categories: the semiconductor industry, automobile production, medical industry, general part manufacturing, and palletizing. Utilization of robots in each of these industries' specific work environments creates greater efficiencies. Whether the job requires speed or precision, robots can quickly and accurately repeat the necessary task without fatigue. There are many different types of robots that are used

in various applications; determining the one that best suits the job description is important for optimal performance.

The semiconductor industry uses robots to make computer chips and components, the production of which requires very precise movements and procedures to ensure all the connections within the component are not faulty. Semiconductor companies also require that there is a sufficient amount of chips being produced so as that they are making money from the product. There are many different robots that can perform this job, but they all have many similarities.

Most of the robots that are used to make semiconductors are multi-jointed and have more than two degrees of freedom. This means that the robots are able to reach the same point in space from multiple angles, which give the robots more flexibility and versatility within the area that they work. Unfortunately this also makes the control systems and programming languages for these robots much more complicated. Accomplished computer programmers must write motion code for these robots based solely on the aspect of path tracking. In addition, semiconductor robots work in designated cells that maintain a certain level of sterilization. These areas are called clean rooms because the ratio of pollution particles to clean air particles is controlled. Robots working in clean rooms are advantageous because they do not emit pollution like a human operator does. However, working within a designated cell confines the space in which the robot must move, so the programmer must take into consideration where the surrounding equipment lies.

A motion path is the path that the robot takes in order to get from one point to another. Basic geometry would tell us that the shortest distance between two points is a straight line but

that is not always achievable in the cells where the robot works. The programmer might have to guide the robot around equipment using several pass-through points in order to avoid hitting anything and damaging the robot or the equipment. This makes the code more complicated because the operator must teach the robot how to execute the code and perform the tasks that have been set for it. Although the robot only needs to be taught once, it can be a time-consuming and expensive process.

The programming of these robots is only one aspect of what makes them work so efficiently in the field. Operators also contribute to any robotics application, and they are required even if there is not a constant monitoring of the robot itself. When the robot is ready to be put into production mode the operator must prepare the machine by cleaning, loading, and starting it. Even though the robot is set inside of a clean area, it requires the operator to clean the area from any of the spills that might occur during the production process. This insures that the product will not be contaminated and makes it safer for anyone that might be handling it in the future. The cells in which the robot works must also be loaded manually. The operator carefully, as to insure that none are broken, must put large cases of wafers of which the chips are built on into place. The machine takes at least 50 of these wafers at a time and can simultaneously produce many computer chips from each wafer. The operator must then start the process by remotely getting the robot into its starting position and telling it what to make. For efficiency each robot is capable of producing more than one type of chip depending on the demand. After the operator has inserted the commands to the central control system the work cell takes over and begins feeding the robot coded commands of what to do. Based on what product is being produced the robot performs a series of commands until the product is completed. This process can take many hours, and the operator can now observe the entire

process remotely from an office or start the process over in another cell. Occasionally the robots do break down from natural wear and need to be replaced or repaired. The operator can typically perform basic maintenance but a trained technician is required for more complicated problems and trouble shooting. Every manufacturer of robots has their own specific field maintenance workers as well as many smaller companies that are certified to work on the robots on site or in a workshop.

Another very large application of robots is the automotive industry. Robots are utilized in many areas from actual car production to fabrication of specific parts. The automotive industry also requires multiple degrees of freedom in their robots as well as a heavy payload arm. Because of the weight of a car, the robot needs to use strong motors as well as strong materials and construction that resist the stress of moving such heavy objects. There are not many companies that produce robotic arms that can lift such heavy items but there are a few that specialize in the task. Kuka robotics is a German company that produces heavy payload robotic arms that can lift up to 1000 kg (Kuka Robotics, 2011). In addition to being very strong, these robots also incorporate six degrees of freedom, which allow the robot to be very agile in its work area. The BMW manufacturing plant in South Carolina has used these robots to weld the frames of some of their car models.

The arms are programmed to work in groups of six, challenging the programmer given the task. Again special attention to motion tracking is very important. The robot controllers not only have to watch for the equipment around them but they must also know where all of the other robots in the cell are. This makes for a very complex dance where the robots dart and weave around each other while quickly accomplishing the task they are set to do. As a result it takes the robots about 15 minutes to fully weld and glue a car frame together before starting on

the next one. The main difference between these robots and the ones that work on the computer chips is that car frames are not manufactured in a clean area. Although the manufacturing plant is kept very neat and clean, there is no need to pay attention to how many particles of pollution are present in the area. This allows the robots to have more space in which to work; nonetheless, space is limited especially since each arm has a reach of over 3 meters and needs to work on the same part at the same time.

The mechanical aspect of these robots is much less due to the fact that these robots are under a great deal of stress even if they do not show it while working so when a problem occurs it typically is more devastating to the machine and needs to be replaced by a new machine or a new part. This means that, unlike semiconductor industry with its premium on programming, technicians need to have more of a background in general mechanics rather than the mechanical workings of the robot.

Automotive robots are not strictly restricted to the heavy lifting of car frames but can be applied to many other areas of the construction of a new car. Many manufacturers use robots in the painting process of their cars. The robots that are applied here are typically six degree of freedom arms that can precisely apply a layer of paint to a car. Due to the unique circumstances of a painting environment robots are again put into a clean room setting, but they must also be able to resist the buildup of excess paint that is in the air. This means that the arms must be cleaned very often so that the paint does not slow them down and put extra strain on the motors. Painting also presents a new challenge to the programmers because it requires the robot to apply paint to every surface of something that it cannot see. Teaching the robot to paint takes longer due to the operator having to manually test and retest the program, due to the unpredictability of application of paint, in order to ensure that the finished product is acceptable.

Robots are also used to create many of the safety features that are used in cars. The most technically advanced of these is the creation of the air bag system. An airbag is deployed in the event of a car crash through the steering console and in most vehicles the sides of the car. In order for these devices to be deployed safely and quickly the areas of which they deploy must be altered in order to minimize impediment but also keep the airbag reasonably unimposing. Some of these systems require the use of robotic laser systems. The robotic arm is equipped with a laser at the end and has a specific pattern that it follows to cut out the desired pattern into the part (Staubli Robotics, 2011). This allows for the air bag to easily push through the perforations and for the part to appear to be solid to the user. As the example of airbags demonstrates, the ability for robots to use tools has become essential for many applications.

Robots in general settings can be found making almost everything. Besides the speed and precision of a robot, a company using robots would increase production through the long operating hours of the machines. Although not all industries can utilize robots, there are many that have been opened up due to a robot's ability to use a tool. Most tools are designed by a company to suit the specific need of that company. This requires an engineer that is well studied in many aspects. The designer must understand how the robot can move and how it is controlled. This would determine the size and features that the designer can use in their design. The control system is especially important so that the designer can teach the system how to use the new tool. Most control systems allow for the user to fabricate their own tools and give a guide as to how you would get the robot to recognize it. This is probably the most complicated aspect of designing the tool because it determines how the circuit needs to be made and what valves would be used if the tool requires air or vacuum input. The wide variety of tools available

for robots allows them to do many different jobs depending on what kind of programming is available.

Another popular use of robots is the use of robots to place finished parts in an order to be shipped. This is not a difficult job but greatly increases the amount of product you can move without having too many workers. A robot will not complain about the work that it is given or the weight of the product being moved. This cuts down on the production cost of a product in the long run even though a robot can be a costly investment. Robots in this line of work can be very simple, only moving in one motion, or they can be more complex depending on how the product is being moved. Heavy payload robots can be used to move 50lb bags of product effortlessly and constantly where low payload robots can move a single pen in to a box very quickly. The simplicity of these robots makes them very good tools for the job.

Robots are widely used in the medical industry as well. This industry requires a very strict type of clean room due to government regulations on medications. Robots in this industry are used for jobs that require the product to be protected from as much contamination as possible. Thus, in this industry, robots are not built to lift heavy objects but rather they are designed to not emit pollutants or have any surfaces that would collect pollution. The operator in this case is used to clean the work area thoroughly before and after every process. It is also crucial that the operator watch the process so as to be sure that no mistakes are made or accidental contaminants get into the product. The programming is also very important as to getting the correct timing down for each step of the process. This is because the medicines and vaccines that we use in everyday life are so common that any mistake could affect lots of people.

From the research it can be determined that the most important aspect of robots in the various industries employing them is the programming. Whether it is a complicated code for teaching the robot a complex path so as to avoid other equipment or just a simple program that allows the robot to quickly place an item in a designated area, the programming aspect of robotics tends to be the majority of the work. The mechanical aspect of robotics is most important in developing these complicated machines. In this regard, kinematics and stress analysis are very important as well as most topics in mechanical engineering. Designing a robot takes a great deal of understanding of what the robot is supposed to accomplish and how the robot will accomplish that task. The robot must be able to quickly or accurately complete the task or even do the task quickly and accurately. Most industrial robots on the market now have a repeatability value of .1mm or less. This means that if a robot was to go to a point in space move away and come back to the same point it would be within .1mm of that point. This is quite an amazing accomplishment considering how fast these machines move.

Through looking at the variety of applications for industrial robots and their importance in these industries we can better understand the importance of having people trained to work with, take care of and design these tools. Industrial Robots while expensive clearly offer distinct advantages for the industries they serve. This is reflected in their wide spread use in high-end manufacturing businesses. Some robots can do things humans can't, or do them more accurately, or faster, or without the need for a break. Just as the uses of these devices are diverse so is the knowledge that they require, from mechanical engineering, to electrical engineering, to computer science many different disciplines are required for robotics. As explained in the next section the diversity of subjects involved provides problems for educators trying to supply new

employees to serve this growing industry. How educators addressed the diversity of subjects is demonstrated in the courses that universities offer.

Curriculum Research

As the Robotics Industry continues to grow in the world economy Robotics Education at the undergraduate level is still in its infancy. To understand the relationship between the robotics industry and curriculum, we also examined which courses universities offered. To better understand the status of undergraduate Robotics Engineering we chose four American schools that represent different categories of the educational market. The first is WPI, a small engineering school. WPI presents a multitude of degree options, but is one of the few schools in the country to offer a full-fledged robotics engineering major. This fact alone makes WPI stand out among other small engineering schools with robotics programs, which is becoming increasingly popular. As one of the only schools in the nation to let undergraduate students work on real robotics projects for companies, WPI has built strong ties to companies that regularly look forward to working with students¹.

Undergraduate students must complete seven of WPI's robotics specific courses to fulfill that portion of the degree requirements. Some of these courses include a four course Unified Robotics series that begins with base level robotics fundamentals in the early courses, all the way up to navigation and inter-robot communication. Most of the courses are taken in the last two years of undergraduate study, as the more difficult courses require the background of many other subjects, like calculus, physics, and electrical engineering principles.

¹ <http://www.wpi.edu/academics/Majors/RBE/on-go414.html>

The second school is Carnegie Mellon University (CMU), a small to medium sized private institution. The school is known for its research, and its robotics program does not disappoint. Undergraduates can earn a minor in Robotics; most students pair this with a major in Electrical Engineering, Computer Science, or Mechanical Engineering. There are over twenty-five offered courses that are related to robotics, but only six of them are directly under the robotics field. A total of three courses are enough to satisfy the minor requirements. A wide-ranging introductory class is the only firm requirement for the minor; the other two courses come from a list of possible courses. They include a course on controls (one must be completed out of three available) and a course describing robotic manipulation, one of two offered.

Another university selected is the University of Maine, a large state university. As with CMU, UMaine offers a robotics minor. Also like CMU, the minor in robotics engineering is often linked with a major in mechanical engineering, electrical engineering, or computer science. The minor requires completion of seven courses: three mandatory courses and four out of five other related courses. This offers undergraduates some flexibility when it comes to specific course scheduling. The required courses delve into the basics of robotics engineering: definition, movement, perception, and control. Later courses are involved with the more technical aspects of robots, such as mechanisms, communications, and signals.

The final American university selected is Johns Hopkins University. This robotics engineering minor is very unique in that the requirements change depending on the student's academic major. There are four possible paths for the students to take to achieve a minor: biomedical engineering, computer science, mechanical engineering, or electrical engineering. The requirements for each path dictate that all students must complete two robotics related courses in their major, and four robotics courses from outside. This means that from a pool of

nearly fifteen courses, there are many ways to reach the six-course requirement. This leads to some robotics-proficient students with vastly different educational backgrounds.

The robotics minor is fundamentally different from the robotics major. The main difference is that the major is a much more specialized engineer, while the minor is broader. This leads to a separation between engineers who are more malleable in terms of adapting to different roles within the field of robotics engineering, and those who are more specialized. American companies prefer to have specialized engineers, but given the low supply of these graduates, stemming from a low number of institutions with a robotics major, the companies settle for unspecialized graduates.

The team selected four Chinese universities to represent the other half of our cross-culture educational research: Shanghai Jiaotong University (SJTU), Harbin Institute of Technology (HIT), Beihang University, and Beijing Jiaotong University (BJTU). These four schools hold similar classifications to the American universities chosen, however they lack the number of courses offered. All of the schools have an introductory level robotics course available, but beyond that the universities differ greatly. SJTU has the most diverse offering, with many courses in intelligent technique and artificial intelligence. HIT offers a course on robot application, and is the only chosen school that does so.

Robotics curriculum in Chinese universities is a growing field; more courses are added each year to the schools' catalogues. In a few years, it would not be unexpected to see nearly two or three times the number of robotics courses in each university². Although many universities have made strides in introducing Robotics Curriculum into undergraduate education Robotics is far from a common offering. This stems from its multidisciplinary nature. In order to examine

² <http://www.robot.sjtu.edu.cn/English/Gaikuang/Default.aspx?cid=6>

some the possibilities for introducing Robotics Engineering to undergraduate engineering we studied pedagogical documents relating to Robotics Engineering and Nanotechnology (another cutting edge multidisciplinary subject). These documents helped us understand both why Robotics isn't more widespread and how the study could be approached at an undergraduate level.

Pedagogical Issues

As technology drives industry forward new challenges confront undergraduate education in terms of producing qualified graduates. The high-tech manufacturing industry has presented such a challenge. Despite a growing industry, undergraduate institutions lag behind in their offerings of robotics education. High-tech manufacturing requires fast, precise, repetitive tasks in high volumes. Companies achieve this by using increasingly sophisticated robotic assembly lines. While the use of robotics in assembly lines has become commonplace in high-tech manufacturing, robotics in the undergraduate curriculum is still underdeveloped. The reasons for this are rooted in the challenges and approaches of educators in tackling this multidisciplinary subject. This essay seeks to make suggestions as to how to expand the robotics curricula within university education. In order to make such suggestions we must examine the challenges educators have faced and the approaches they have used.

While educational institutions are commonly divided into individual disciplinary fields, new fields are emerging which blur the lines between traditional disciplines. These fields provide many challenges to institutions when creating a new, interdisciplinary program. To better understand the challenges of creating classes for a multidisciplinary subject we will

examine nanotechnology and robotics engineering. The main foci of this essay are robotics engineering and suggestions on how a well-chosen curriculum can meet industry needs. Given the newness of the robotics field in undergraduate education, nanotechnology will be used as an example of how the academy met the challenge of incorporating another, now slightly less new, multidisciplinary field into undergraduate engineering. There is also much to be learned from early attempts to incorporate robotics engineering curriculum into other engineering course work. In addition, we must examine industry needs before we can make curricular suggestions. Finally we will provide some suggestions for creating a meaningful robotics-engineering curriculum that meets industry's needs and advances the technology of the field.

Nanotechnology is a sound case study not only because it is a multidisciplinary field but also because, like robotics engineering, is a discipline with growing demand which requires high level math and is typically reserved for graduate level education. Despite the difficulties of incorporating higher level subjects into the undergraduate curriculum, it is necessary to do so in order to create undergraduate programs that support the growth of these promising industries.

Nanotechnology according to Mahbub Uddin's definition is a subject that encompasses

“...basic sciences (atomic physics, molecular chemistry, microbiology, genetics, etc.), engineering sciences (mechanical, electrical, chemical, biochemical, computer etc.), and information sciences (molecular coding, data analysis, imaging and visualization, bio-computation, molecular modeling and simulation of complex structures...”³

³ Mahbub Uddin, A. Raj Chowdhury. Integration of Nanotechnology into the Undergraduate Engineering Curriculum: Sesson 8B2 (Oslo, Norway: International Conference on Engineering Education, 2001), 6.

This multidisciplinary subject has presented many educators with difficulty as to how to incorporate this subject into undergraduate education. Yet as industries change so must education. There is much difficulty in managing the breadth of a multidisciplinary subject while maintaining both depth and focus. These challenges are not without benefits as multidisciplinary subjects offer opportunities to bring together engineers from many disciplines to work on challenging projects, which teach students to apply knowledge from disparate disciplines in creative ways. Educators must take advantage of these opportunities and overcome the challenges if they are to supply the growing industry with the skilled graduates it needs. These changes must not just be superficial, but must be as widespread as possible. At a major conference on nanotechnology introduction of three courses into undergraduate program: the first was an introductory course (Fundamentals of Nano science) required for all engineering students, the second was a junior/senior level course (Synthesis, Processing and Manufacturing of Nano components and Nano systems) that would be an elective for most majors and a requirement for others and finally an advanced senior level nanotechnology elective course (Design, Analysis and Simulation of Nanostructures and Nano devices).⁴ This approach, while it does not allow the depth of a major, forces all engineers to be exposed to nanotechnology and appropriate majors to have a more in-depth knowledge of nanotechnology. According to Wendy Crone “...nanotechnology concepts have been incorporated into undergraduate general chemistry and physics courses. Universities now offer courses with a significant component

⁴ (Mahbub Uddin, 2001), 8.

dedicated to nanotechnology.”⁵ While the incorporation of nanotechnology has been slow, it is encouraging that progress is being made in a field similar to robotics engineering.

Robotics engineering, like nanotechnology, is a growing field, which has only begun to be introduced into undergraduate education. If the robotics industry is to grow, the effort to introduce robotics to undergraduate curriculums must be expanded further. As the largest portion of the robotics industry is industrial robotics, robotics education is important to most every high-tech manufacturing business. Before we discuss the importance of robotics to the industry, the advantages of robotics engineering as a pedagogical tool should be discussed. Robotics engineering, as a focus, can be used to demonstrate many important concepts for any sort of engineering major. At Tufts University Robotics was used to introduce engineering design, beginner level physics, and the correct process for experimentation.⁶ Robotics engineering is invaluable because it provides a diverse platform for practical learning for any engineering major. Finally, being a complex and multidisciplinary major, Robotics Engineering is useful to teach teamwork, both within a major and in an interdisciplinary setting. This broad and interdisciplinary education despite traditions of narrow subjects in education is demanded by industry. This demand comes from the still growing incorporation and blending of technologies in the industry and in education. While this is by no means a new phenomenon, the merging of technologies has finally blurred the lines between many types of engineering curriculum. This integration trend reflects the industry’s need as “Feedback from many employers continues to

⁵ Nanotechnology into the Materials Science and Engineering Classroom and Laboratory . (Madison, WI: Departmental Papers: Department of Mechanical Engineering & Applied Mechanics, American Society for Engineering Education, 2003), 2.

⁶ Scott McNamara, Martha Cyr, Chris Rogers, Barbara Bratzel. LEGO Brick Sculptures and Robotics in Education. (Medford/Somerville, MA: Tufts University), 2-3.

indicate a declining need from narrow, specialist graduate engineers.”⁷ The need for less narrowly educated engineers is even more pressing in automated manufacturing, and according to Paul Robinson, “All high volume manufacturing now relies on robots to produce the consistent quality, flexibility and predictable work rate necessary for commercial success.”⁸ It is apparent then, that there is a large need for engineers with broad educational background to work in the high tech manufacturing industry. Robotics can fill many roles within education and can be important to fill the needs of the industry. According to Paul Robinson “Robotics may be considered a subset of manufacturing technology. Its technology, training requirements and problems are the same.”⁹ While robotics engineering is multifaceted, robotics-engineering curricula should focus on manufacturing and industrial applications if they are to serve industry need.

Many educators would not consider the topics of robotics so narrow; however this close association is demonstrative of robotics education’s importance to serving industry needs. How can robotics solve both the problems of providing broadly educated engineers and engineers capable of working in the high-tech manufacturing industry? It is because robotics engineering is a broad multidisciplinary topic. Through research we determined that robotics engineering encompasses more than eight disciplines. Broad and multifaceted robotics engineering can be used to introduce broad multidisciplinary topics (such as industrial robotics) to more traditionally narrowly focused engineering majors. In addition, robotics engineering is an important aspect of high-tech manufacturing, and can be used to produce engineers capable of working in that field.

⁷ Paul Robinson, Robotics education and training: a strategy for development, (Industrial Robot: An International Journal, Vol. 23 Iss: 2), 7.

⁸ Paul Robinson. A New Robotics Degree: The Plymouth Experience. (London, U.K.: IEE, 1995), 2.

⁹ (Robinson, Robotics education and training: a strategy for development, 1996), 4.

While it seems that broadening majors is counterintuitive and counterproductive to a traditional, focused education in engineering, manufacturers truly need the generalist. If a generalist is needed how can educators bring focus to such broad topics such as systems engineering or manufacturing engineering? We determined that robotics engineering could simultaneously bring more interest to broader topic courses and bring a sharper focus to them.

While companies that produce industrial robotics products need general robotics engineers, these kinds of education programs have not yet become prevalent. As it was with nanotechnology in its earliest days, universities have been slow to respond to industry need. By looking at what industrial robotics companies look for in robotics engineers, we can see what sorts of engineering is most related to robotics engineering in the industry. An example of a large American industrial robotics company is Adept, and as they describe themselves “Adept Technologies Inc. is a global, leading provider of intelligent vision-guided robotic systems and services.”¹⁰ They also mention the importance of “...intelligent automation is key to the success of any medium or high volume discrete manufacturing enterprise...”¹¹ Logically, an industrial robotics company would try to sell the importance of automation in manufacturing. Educators, journalists and industry figures also corroborate this need. So what does Adept look for in an engineer? According to the only job opening description available at the time of this reports’ publication, the company seeks someone with experience in “Automation, robotics and/or computer hardware”¹² and educated in engineering or computer science. While information from other major industrial robotics companies is thin, another robotics company Motoman provides a description of the majors they find desirable. Motoman looks for those educated in

¹⁰ (Adept, 2011)

¹¹ (Adept, 2011)

¹² (Adept, 2011)

“Project Management/ Mechanical Engineering/Electrical Engineering/Controls Engineering”¹³.

Both Adept and Motoman’s descriptions of the engineering fields they find valuable fall right in line with many of the aspects of robotics engineering.

Based on lessons from nanotechnology, educators suggestions, industry needs, and industry hiring practices, there is a clear need for a developed Robotics curriculum. This curriculum needs to provide broadly educated engineers who focus on industrial robotics, and offer breadth to many of the narrowly focused traditional engineering majors’ curriculums. Similarly to nanotechnology curriculum could enhance introductory courses, incorporating introductory robotics classes to introduce early concepts in engineering could offer many benefits. First, it could give first year students an early look at a broad spectrum of engineering disciplines, and offer context to explain the importance of many early engineering courses. In addition, it would encourage many engineers to take more courses in robotics engineering, and possibly encourage some to minor or major in robotics engineering.

Conclusion

After completing all the research and conclusions on our project we came to one unanimous conclusion. The research from both the industrial robotics review and the professor reviews suggest that robotics is moving more and more towards the industrial setting. Upon doing the research 90% of all robotics was already classified as industrial with manufacturing grabbing the most of the market. This suggests that robotics engineers need to be trained for the industrial robotics application and that well-rounded robotics knowledge will best prepare

¹³ (Motoman, 2011)

these engineers for future careers. From our research in current robotics courses we discovered that most of the current courses offered at schools did have an industrial aspect but also focused on a specific application of robotics. In total these classes can create a full and extensive robotics education. By catering classes towards providing a general industrial robotics engineer students can satisfy the need for well-educated engineers in the industrial field. These classes can greatly educate their students to provide a student that will be able to adapt to any industrial application they might encounter in the future.

Robotics education is becoming very important to all industries due to the constantly advancing robotics technology. Many different areas of application of robotics are being exposed all the time and it is only a matter of time before robots find their way into everyday life. A few of the more popular possibilities are robotics surgery and robotic consumer products. The precision and speed of a robot makes surgery an enticing possibility for the application of these tools and by having a robot conduct surgery, the cleanliness of the operating table greatly increases. Consumer products are always becoming more robotic as products are able to do many more functions without user input. The ability for these machines to gather information and interact with their environment make them very capable of making their way into the consumer product market. The advancement of vision systems into more robotics applications will help to make robots more capable of being incorporated into more industrial applications. Using the research we have put together in this paper, we hope to provide a guideline for future applications of robots and information that will help people to advance robotics technology. By

taking the information here and applying it to specific robotics technology people will be able to form a solid base to advance their technology and future research.

Appendix

Johns Hopkins University						
Course name	530.343 Design and Analysis of Dynamic Systems	530.420 Robot Sensors and Actuators	530.424 Dynamics of Robots and Spacecraft	530.646 Introduction to Robotics	520.353 Control Systems	600.336 Algorithms for Sensor based Robotics
Required for major or elective	Required	Required	Required	Required	Elective	Elective
Year taken	Junior	Senior	Senior	Junior	Junior	Senior
Course subject	Systems Analysis	Environment, Sensors	Physics and robots	Overview	System construction	Applying algorithms to robots sensors
Required background courses/knowledge	Calculus, CS	Calculus	Calculus, Physics	Calculus	CS, Linear algebra	CS, Intro to robotics
Special notes	Note: Some of these courses are cross listed, and can count towards the Major specific requirement for some of the different versions of the minor.					

Figure 1

Special note: At JHU, the Robotics Minor is determined by your academic major. Each minor candidate must complete 4 robotics electives within their major, as well as 2 electives outside their major. Because of this, there are four (4) different possible charts that could be constructed. For the sake of simplicity, the chart represented here is for a sample Mechanical Engineering major.

Carnegie Mellon University						
Course name	16-311 Introduction to Robotics	18-370 Fundamentals of Controls	24-451 Feedback Control Systems	16-299 Introduction to Feedback Control Systems	15-384 Robotic Manipulation	24-355 Kinematics and Dynamics of Mechanisms
Required for minor or elective	Required	Any ONE of these three courses is required			Any ONE of these courses is required	
Year taken	Junior	Junior	Junior/Senior	Junior	Junior	Junior/Senior
Course subject	Broad intro	Stability, response	Analysis and design	Response, domain	Intro to manipulation	Rigid body dynamics
Required background courses/knowledge	Differential equations, Integral calculus	MATLAB	Calculus	Calculus, CS		
Other information	None	None	None	Not available for ME and ECE major students	May take 16-741 instead, this is a graduate level manipulation course	None

Figure 2

Diagram showing the course information for Carnegie Mellon University

University of Maine								
Course name	MEE 270 Applied Mechanics: Dynamics	ECE 417 Introduction to Robotics	MEE 498 Robot Dynamics and Control	MEE 370 Modeling, Analysis and Control	MEE 380 Design 1	ECE 414 Feedback Control Systems	ECE 478 Industrial Computer Control	ECE 487 Digital Image Processing
Required for major or elective	Required	Required	Required	Four out of these five courses are required				
Year taken	Junior	Senior	Senior	Junior	Senior	Senior	Senior	Senior
Course subject	Impulses, Acceleration	Structure, application		Mechanical, thermal, hydraulic systems	Mechanisms, linkages	Signal flow graphs, Observability	Interface electronics, communication	Advanced image logarithm
Required background courses/knowledge	The following courses MUST be completed before a student can select the Robotics Minor: MEE 150, (ECE 209 or ECE 210), (COS 220 or ECE 177).			MEE 270	MEE 270	ECE 314	No additional courses	No additional courses
Special Information	None	None	None	None	None	None	None	None

Figure 3

Diagram showing the course information for University of Maine

WPI							
Course name	RBE 1001 Introduction to Robotics	RBE 2001 Unified Robotics 1	RBE 2002 Unified Robotics 2	RBE 3001 Unified Robotics 3	RBE 3002 Unified Robotics 4	RBE 4322 Modeling and analysis of mechatronic systems	RBE 4815 Industrial Robotics
Required for major or elective	Required	Required	Required	Required	Required	Elective	Elective
Year taken	Freshman	Sophomore	Sophomore	Junior	Junior	Senior	Senior
Course subject	Basic introduction	Energy, Kinematics	Sensors, Feedback	Interface, Program ming	Navigation , Communication	Computer simulation s, model building	Classification, transmission
Required background courses/knowledge	Physics 1	Physics 2, Static systems, RBE 1001	RBE 2001, Intro to CS	RBE 2002, Differential equations	RBE 3001, Statistics	Math, fluids, thermodynamics, static systems	Manufacturing, kinematics, programming
Special information	None	None	None	None	None	None	None

Figure 4

Course information for Worcester Polytechnic Institute

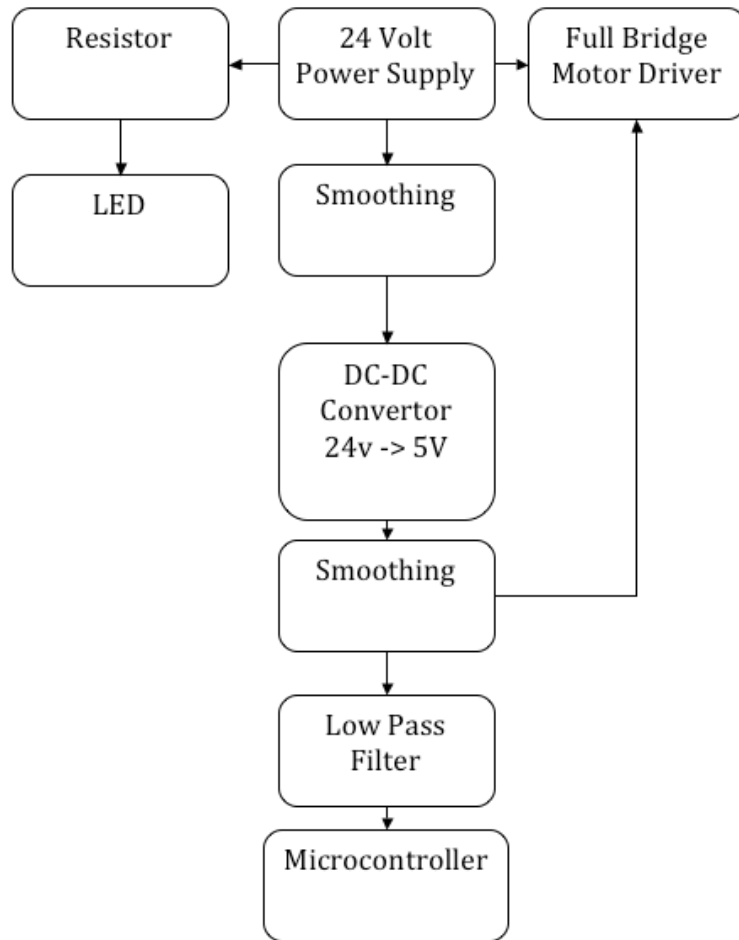

Figure 5

Diagram showing the flow of the power supply for Beijing robots.

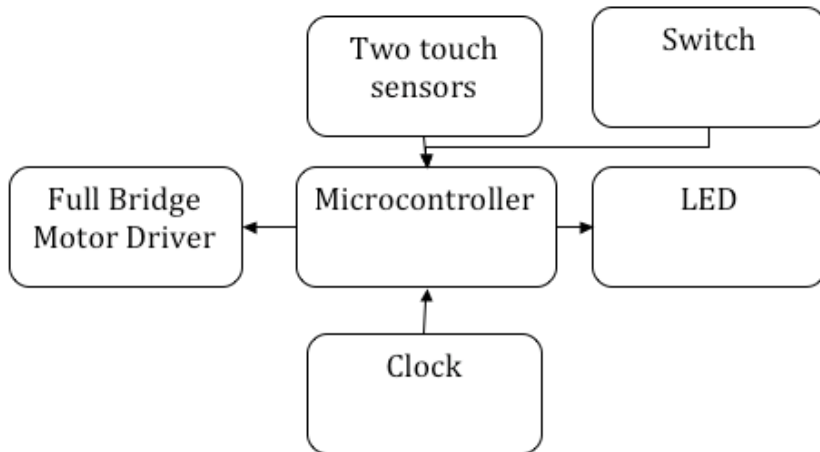

Figure 6

Diagram showing the controller logic for Beijing robots



Figure 7

Illustration of parallelogram robot made by BJTU students

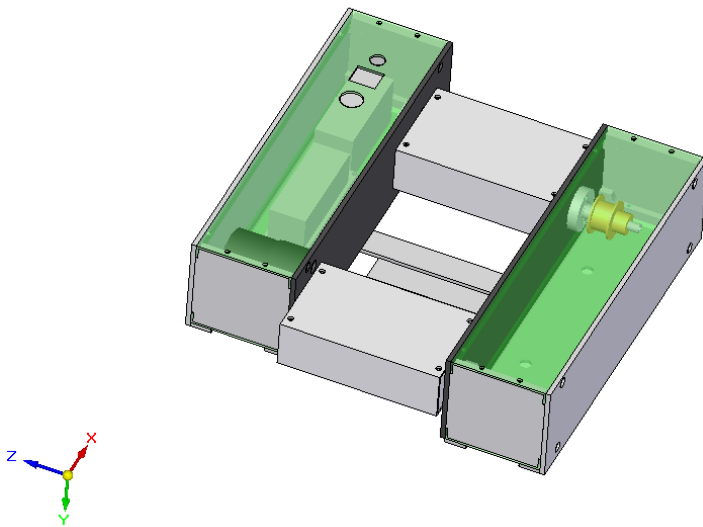

Figure 8

Illustration of four-bar walking robot made by BJTU students

Works Cited

(n.d.). From Lynxmotion, Inc.: <http://www.lynxmotion.com/p-419-rios-ssc-32-arm-control-software.aspx>

Wendy C. Crone, A. B. (2003). *Incorporating Concepts of Nanotechnology into the Materials Science and Engineering Classroom and Laboratory*. Madison, WI: American Society for Engineering Education.

Adept. (2011). *Adept: Your Intelligent Robotics Partner*. Retrieved 2 7, 2011, from <http://www.adept.com/>

Asakura, M. M. (1999). Manipulator visual servoing and tracking of fish using a genetic algorithm. *Industrial Robot: An International Journal*, pp. 278-289.

Bejczy, A. K. (n.d.). *Robot Arm Dynamic Control by Computer*. From NASA Space Telerobotics Program: http://ranier.hq.nasa.gov/telerobotics_page/technologies/0414.html

D.M. Wilkes, A. A. (1999). Designing for Humanrobot Symbiosis. *Industrial Robot*, 49-58.

International Day of Older Persons. (n.d.). Retrieved 10 08, 2010 from United Nation: <http://www.un.org/zh/events/olderpersonsday/background.shtml>

Heping Chen, G. Z. (2009). Assembly on moving production line based on sensor fusion. *Assembly Automation*, 257-262.

Kuka Robotics. (2011, January 1). *Kuka robotics*. Retrieved April 22, 2011, from Kuka: http://www.kuka-robotics.com/usa/en/products/industrial_robots/heavy/kr1000/

maxon motor. (n.d.). Firmware Specification.

Mahbub Uddin, A. R. (2001). Integration of Nanotechnology into the Undergraduate Engineering Curriculum: Sesson 8B2. *International Conference on Engineering Education*, (pp. 6-9). Oslow, Norway.

Motoman, Y. (2011). *Yaskawa Motoman*. Retrieved 27, 2011, from <http://www.motoman.com/index.php>

Ponsler, A. H. (2010, April 30). Blob Detection with Open CV. (J. Noser, Interviewer)

Scott McNamara, M. C. *LEGO Brick Sculptures and Robotics in Education*. Medford/Somerville, MA: Tufts University.

Staubli Robotics. (2011, January 1). *Laser cutting robots*. Retrieved April 22, 2011, from robot solution applications: <http://www.staubli.com/en/robotics/robot-solution-application/laser-cutting-robot/>

Robinson, P. (1995). *A New Robotics Degree: The Plymouth Experience*. London, U.K.: IEE.

Robinson, P. (1996). Robotics education and training: a strategy for development. *Industrial Robot: An International Journal*, Vol. 23 Iss: 2, 4-11.

RoboRealm. (2010). *Fiducial*. Retrieved May 2010 from RoboRealm: vision for machines.