

April 2017

Smart Home Energy Controller

Andrew William Reyburn
Worcester Polytechnic Institute

Eric Philip Meier
Worcester Polytechnic Institute

Follow this and additional works at: <https://digitalcommons.wpi.edu/mqp-all>

Repository Citation

Reyburn, A. W., & Meier, E. P. (2017). *Smart Home Energy Controller*. Retrieved from <https://digitalcommons.wpi.edu/mqp-all/2910>

This Unrestricted is brought to you for free and open access by the Major Qualifying Projects at Digital WPI. It has been accepted for inclusion in Major Qualifying Projects (All Years) by an authorized administrator of Digital WPI. For more information, please contact digitalwpi@wpi.edu.

Smart Home Energy Controller

April 12, 2017

A Major Qualifying Project Report Submitted
to the faculty of WORCESTER POLYTECHNIC INSTITUTE
In partial fulfillment of the requirements for the
Degree of Bachelor of Science

An MQP by:

Andrew Reyburn, awreyburn@wpi.edu
Eric Meier, epmeier@wpi.edu

Submitted to:

Professor Fred Looft, ECE and SE



This Major Qualifying Project is submitted in partial fulfillment of the degree requirements of Worcester Polytechnic Institute. The views and opinions expressed herein are those of the authors and do not necessarily reflect the positions or opinions of Worcester Polytechnic Institute

Abstract

The purpose of this project was to design a prototype device that could address the two main issues the team identified with existing residential solar systems: specifically, the inability to use solar power when the grid is offline and the inability to dynamically allocate power in a reconfigurable manner, depending on the power available from a solar PV system. The team researched solar system topologies and components, used a systems engineering approach to design a potential solution, and then built and tested a proof of concept device referred to as smart home energy controller. This report details the current state of solar PV system architectures, identifies current PV system design limitations, and explains the team's proposed solutions. The group also addresses the final PV system designs and the technical challenges encountered with the technologies used in the prototype test setup.

Acknowledgements

We would like to acknowledge our advisor Professor Looft in his guidance and encouragement for us to keep trying something new and pushing us to achieve our best. We would also like to acknowledge and thank Jim Dunn for his professional advice and help in this project. Without his insights, the team would have faced a much more difficult time in implementing the prototype.

Table of Contents

Table of Figures	i
Table of Tables	iii
1.0 Introduction	1
1.1 Introduction.....	1
1.2 Project Statement.....	3
1.3 Summary	3
2.0 Background.....	4
2.1 Introduction.....	4
2.2 System Coupling and Wiring	4
2.2.1 AC Solar System Coupling.....	4
2.2.2 DC Solar System Coupling	5
2.2.3 Split Phase Power	6
2.2.4 Home Grounding System.....	7
2.3 Solar Inverters for Grid Tie and Off-Grid	8
2.3.1 Introduction to Inverters.....	8
2.3.2 Central Inverters	9
2.3.3 Microinverters.....	10
2.4 System Layouts for Hybrid Grid Tied Solar With Batteries	11
2.4.1 Hybrid Grid Tie System with Battery Backup.....	11
2.4.2 SMA Technologies Hybrid Grid Setup	13
2.4.3 SolarEdge.....	14
2.4.4 Schneider Electric	17
2.5 Batteries	19
2.5.1 ABB REACT Battery.....	19
2.5.2 Tesla Powerwall	20
2.6 Charge Controllers	22
2.6.1 Battery Charge Controllers.....	22
2.6.2 Solar Charge Controllers and MPPT	22
2.7 Automatic Transfer Switches	22
2.8 Islanding Detection Methods	26
2.9 Switching Transients.....	27
2.10 Summary.....	29

3.0 Problem Statement.....	30
3.1 Introduction.....	30
3.2 Problem Statement	30
3.2.1 Perform Background Research.....	31
4.0 System Concepts.....	32
4.1 Introduction.....	32
4.2 Stakeholder Analysis.....	32
4.2.1 Stakeholders.....	32
4.2.2 System Needs	33
4.3 CONOPS.....	35
4.3.1 Expected Operational Environment	35
4.3.2 Use Cases	35
4.3.3 Gap Analysis	38
4.3.6 Design Needs	39
4.3.4 System Specifications	40
4.4 Final System Architecture	41
4.4.1 System Architecture	41
4.4.2 System Control Logic	43
4.5 Summary	44
5.0 Prototype Test System Design.....	45
5.1 Introduction.....	45
5.2 The Setup.....	45
5.2.1 Electronically Controlled Breakers.....	46
5.2.2 Pure Sine Wave UPS	46
5.2.3 Voltage Sensor.....	46
5.2.4 The Current Sensor.....	47
5.2.5 The Microinverter.....	47
5.2.6 Microinverter Wiring	48
5.2.7 Arduino Mega Board	49
5.2.8 Microcontroller Wiring.....	49
5.2.9 Custom MOSFET Protoboard.....	51
5.3 System Testing Procedure.....	51
5.4 Component Verification.....	54
5.4.1 UPS Testing	54

5.4.2 Microinverter Testing.....	57
5.4.3 Voltage Sensor Testing.....	57
5.4.4 Microcontroller Verification.....	58
5.4.5 MOSFET Board Testing.....	59
6.0 Integrated System Testing and Results.....	60
6.1 Introduction.....	60
6.1 Microinverter Testing Results.....	60
6.2 UPS with Microinverter Testing Results.....	61
6.3 Solar Panel Testing Results.....	63
6.4 Controller Testing Results.....	64
6.4.1 Current Sensor.....	64
6.4.2 Voltage Sensor.....	66
6.4.3 Microcontroller.....	67
6.5 Smart Home Energy Controller Test Results.....	68
6.6 Distortion Source Testing.....	68
6.6.1 Transformer Testing.....	68
6.6.2 Light Bulb Testing.....	69
6.7 Transient Testing.....	70
6.8 Results Summary.....	72
7.0 Conclusion.....	73
Appendices.....	74
Appendix A. Color Coded System Level Functional Block Diagram (Power).....	74
Appendix B. Color Coded System Level Functional Block Diagram (Data).....	75
Appendix C. Color Coded System Level Functional Block Diagram (Signals).....	76
Appendix D. Zoomed in UPS Transfer Time.....	77
Appendix E. Simulation Oscillogram for Voltage Sensor.....	78
Appendix F. Linearity of Voltage Sensor.....	79
Appendix G. Wiring Diagram for BABRP1020 Breaker.....	80
Appendix H. Arduino Optimization Code.....	81
Appendix I. SolarEdge Single Phase Inverter SE3000A-US.....	87
Appendix J. Maximum Power Point Tracking.....	88

Table of Figures

Figure 1. Solar PV Growth Predictions ¹	1
Figure 2. Power Outages Due to Extreme Weather	2
Figure 3. AC Coupled System	5
Figure 4. DC Coupled Solar System	6
Figure 5. Utility Distribution Transformer and Split Phase Power.....	7
Figure 6. Home Grounding System.....	8
Figure 7. Inverter Waveform Outputs	9
Figure 8. Enphase M190 Microinverter	10
Figure 9. A Grid-tie System with Battery Backup.....	12
Figure 10. Sample SMA Grid-tie with Battery Backup Configuration	13
Figure 11. SolarEdge StorEdge Solutions	15
Figure 12. SolarEdge StorEdge Single Phase Inverter.....	16
Figure 13. SolarEdge Wi-Fi Communication Solution.....	16
Figure 14. Conext XW Hybrid Grid Tie System.....	17
Figure 15. Schneider Electric Conext XW+ Solar Hybrid Inverter System	18
Figure 16. ABB REACT Battery and Inverter ³⁴	19
Figure 17. Tesla Powerwall 2	20
Figure 18. High Level Generator and Transfer Switch Setup	23
Figure 19. S&C Source Transfer Operating States.....	25
Figure 20. Impulse Transient.....	27
Figure 21. Oscillatory Transient.....	28
Figure 22. System Level Functional Block Diagram	41
Figure 23. State Flow Logic for Controller Algorithm	43
Figure 24. Main Test Bed Wiring Diagram	46
Figure 25. Custom AC Voltage Sensor Schematic	47
Figure 26. Solar System Power Wiring Diagram.....	48
Figure 27. Arduino Mega Board	49
Figure 28. Microcontroller Diagram for Sensors and Electronic Breaker Controls.....	50
Figure 29. Microcontroller Diagram Additional Electronic Breaker Controls	51
Figure 30. Mounted Test Setup	52
Figure 31. APC Back-Up UPS RS 1200 Main Waveform	55
Figure 32. APC Back-Up UPS RS 1200 Inverter Waveform	55
Figure 33. CyberPower UPS Grid to Battery Power Waveform	56
Figure 34. CyberPower UPS Battery to Grid Power Waveform	56
Figure 35. Voltage Sensor Readings	58
Figure 36. Microinverter Line Two (Blue) and AK (Yellow) Voltage Waveform.....	61
Figure 37. UPS and Microinverter On-Grid to Off-Grid Transition	62
Figure 38. Off-grid to On-grid Transition	63
Figure 39. Current vs Voltage Waveforms Pushing Power into Test Bed.....	64
Figure 40. Current Sensor Output Waveform with All Loads On.....	65
Figure 41. Distorted Current Sensor Waveform When Pushing Power into AK.....	65
Figure 42. Current Sensors Output Waveform - Mostly in Phase	66
Figure 43. Voltage Sensor Output Graph.....	67

Figure 44. Transformer fed by Function Generator, 10V Peak at 60Hz.....	68
Figure 45. Waveform Comparison - CFL in Blue, AK in Yellow	69
Figure 46. Waveform Comparison - Incandescent in Yellow, AK in Blue.....	69
Figure 47. On-Grid Voltage Sag Caused by Motor Operation	70
Figure 48. Off-Grid Voltage Sag Caused by Motor Operation.....	71
Figure 49. Off-Grid Voltage Sag Closeup Due to Motor Operation	71
Figure 50. Electronic Breaker Transient Testing - Breaker Closing and Restoring Power	72

Table of Tables

Table 1. Stakeholders and their Interests	32
Table 2. System Needs	34
Table 3. Use Case for Selecting Circuit Prioritization	36
Table 4. Use Case for Measuring Power Flows	37
Table 5. Use Case for Pressing the Emergency Stop Button.....	38
Table 6. Gap Analysis.....	38
Table 7. Design Needs	39
Table 8. Electrical Specifications.....	40

1.0 Introduction

1.1 Introduction

Recent data from the Solar Energy Industries Association (SEIA) shows an overwhelming surge in home solar installations.¹ Figure 1 displays the yearly installed solar capacity from 2010 to the expected installed capacity by 2021. The yearly installed capacity is divided into three categories: residential, non-residential, and utility. Residential solar capacity is indicated in green on the graph. The orange segment (or non-residential) is solar capacity installed on business or other non-residential sites. The final segment is utility solar in the form of utility scale solar power plants and is shown in blue. This data shows a rise in expected installed capacity, which introduces load balancing issues during power outages as solar power cannot be used during the outage. As yearly U.S. solar installations increase, coupled with increasing outages due to extreme weather events, there will be a rise in situations in which homeowners that have solar power will be unable to use their solar power.

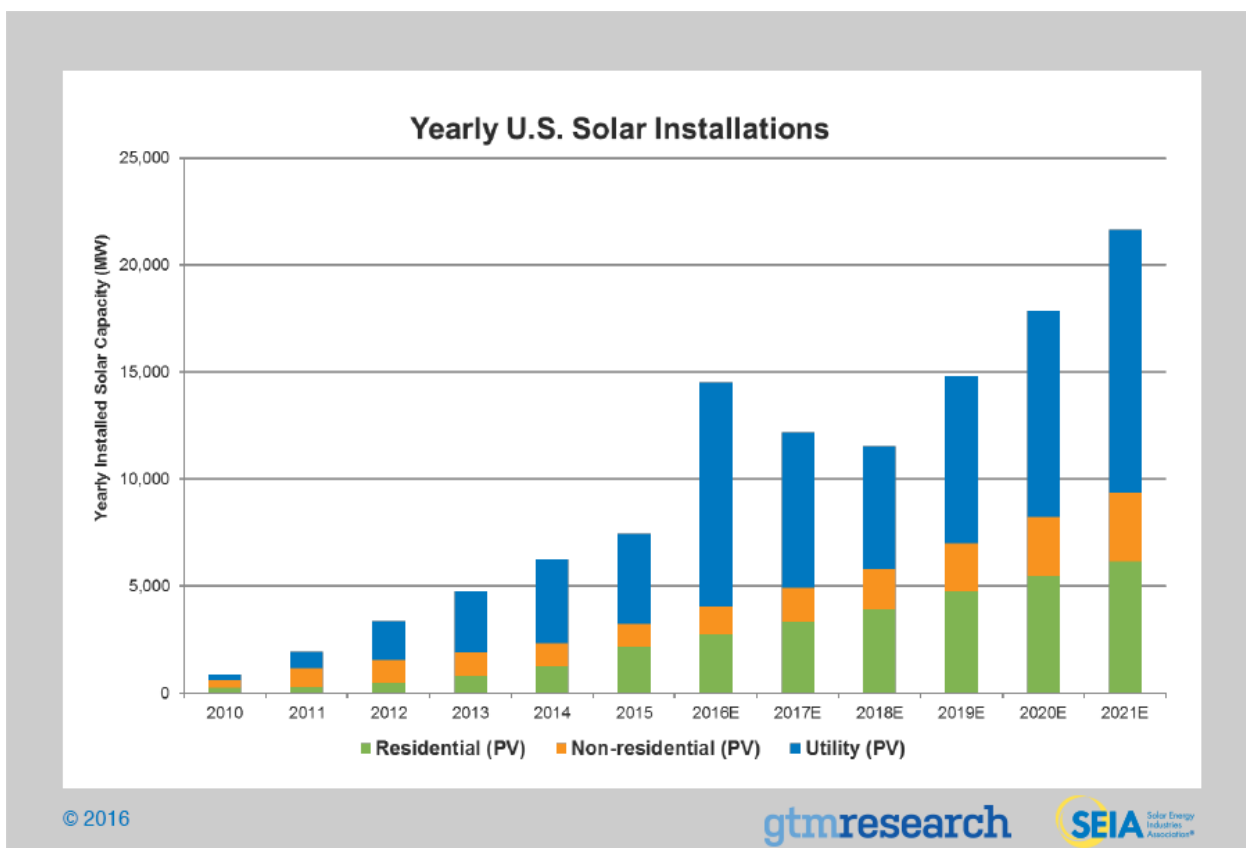

Figure 1. Solar PV Growth Predictions¹

¹ SEIA. (2016). *Yearly U.S. Solar Installations* [Online image]. Retrieved January 23, 2017 from <http://www.seia.org/sites/default/files/fig8-USSolarPVForecastQ12016.png>

In general, residential home solar systems are not independent of the grid as they require a constant grid connection to operate. If an outage occurs, the solar inverters used in the solar system must shut down almost immediately per utility regulations. The implications of this are that even if the solar power system is generating power it cannot be fed into the residential building in the event of a power outage. The back feeding of power into the grid is prohibited during an outage to avoid energizing distribution lines that line workers may be working on.

As climate change accelerates, increasing extreme weather events are causing more power outages. Figure 2 from Climate Central shows the number of outages affecting at least 50,000 customers or more from 1984 to 2012.² The graph shows that the growth of major power outages events is accelerating following the turn of century. The number of power outages from 2000 to 2013 have increased by 600% according to Inside Energy.³ These power outages currently cost American households around \$150 billion annually with each unplanned outage costing about \$8,852 per minute on average.⁴ ⁵ The \$8,852 figure is based on a calculation that takes into account certain factors resulting from no electricity such as: costs due to lost productivity, damaged pipes and equipment due to cold weather, flooded basements, and food spoilage.

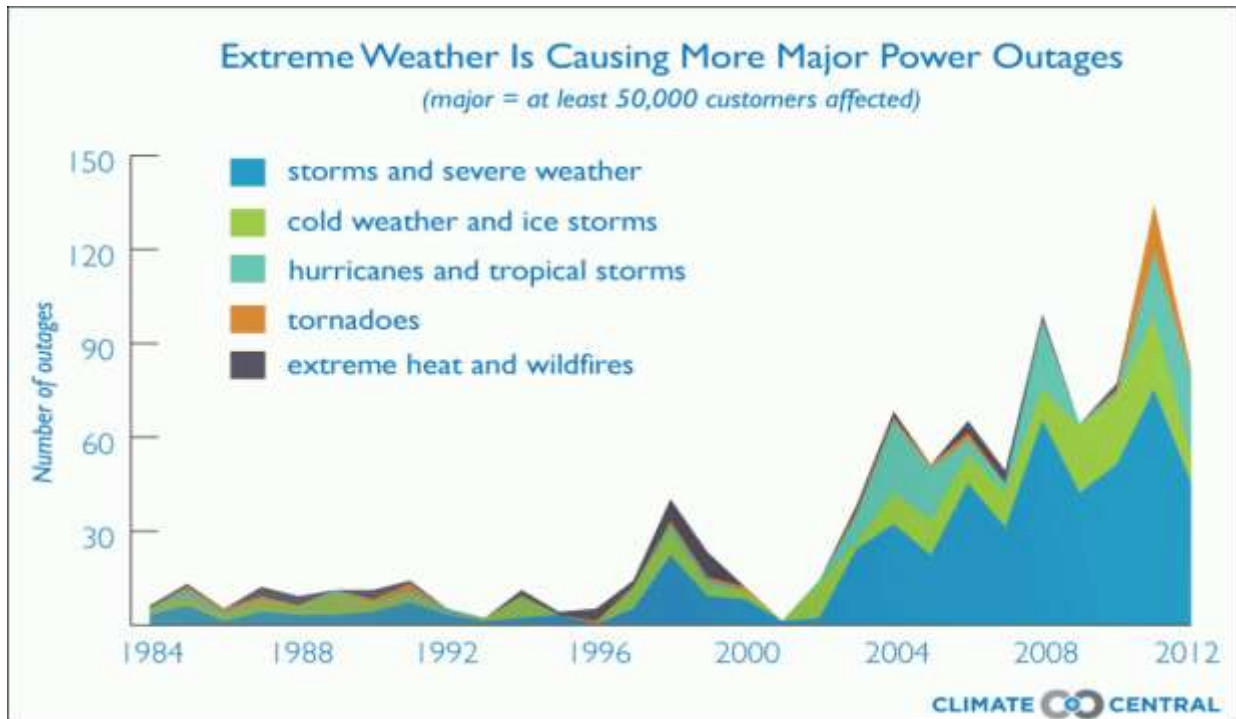

Figure 2. Power Outages Due to Extreme Weather⁶

² Kenward, A., & Raja, U. (2014). *Blackout: Extreme Weather, Climate Change and Power Outages*. Princeton: Climate Central. Retrieved from <http://www.climatecentral.org/news/weather-related-blackouts-doubled-since-2003-report-17281>

³ Wirfs-Brock, J. (2014, August 18). *Power Outages On The Rise Across The U.S.* Retrieved from Inside Energy: <http://insideenergy.org/2014/08/18/power-outages-on-the-rise-across-the-u-s/>

⁴ Emerson. (2016, January 19). Emerson Network Power Study Says Unplanned Data Center Outages Cost Companies Nearly \$9,000 Per Minute. Retrieved from Vertiv: [https://www.vertivco.com/en-us/about/newsroom/corporate-news/emerson-network-power-study-says-unplanned-data-center-outages-cost-companies-nearly-\\$9000-per-minute/](https://www.vertivco.com/en-us/about/newsroom/corporate-news/emerson-network-power-study-says-unplanned-data-center-outages-cost-companies-nearly-$9000-per-minute/)

⁵ Kohler Generators. (2014, August 08). The Cost of Power Outage in the U.S. Retrieved from Kohler Generators: http://www.kohlergenerators.com/common/pdf/RES_Infographic.pdf

⁶ Kenward, A., & Raja, U. (2014). *Blackout: Extreme Weather, Climate Change and Power Outages*. Princeton: Climate Central. Retrieved from <http://www.climatecentral.org/news/weather-related-blackouts-doubled-since-2003-report-17281>

1.2 Project Statement

The purpose of this project was to address the inability of residential solar systems to supply power to a house during a power outage by islanding a home and incorporating the ability to dynamically allocate available solar power. The goal of this project was to design and demonstrate a conceptual device that would enable homeowners to use their solar panels when a grid outage has occurred in a regulation compliant manner using dynamic power allocation. The objectives of this project were to: perform background research on solar systems, explore system architectures of existing solar systems, design the smart home energy controller, and create a small-scale demonstration of the prototype system design.

1.3 Summary

The problems that this project seeks to address are those caused by the increasing market penetration of residential solar systems and an increasing rate of power outages, during which a residential solar system cannot function. With a projected growth in expected installed solar capacity and in extreme weather events damaging the power system, residential solar systems should possess the ability to island a home and continue to provide power even when the main utility connection is offline. To enable these features for current residential solar systems, the team conducted background research on solar systems, designed the smart home energy controller, and performed testing and validation.

2.0 Background

2.1 Introduction

The background section provides a brief overview of the various technologies behind a residential solar system and those that are needed to build the smart home energy controller. The main focus of the research was to examine the technology incorporated in off-grid and hybrid solar systems to island a home with respect to the utility grid which is for a solar system to operate during a power outage. In addition to off-grid systems, on-grid system layouts and architectures are reviewed to study how current systems work and their limitations. The background research then delves into the individual components of a solar system. The three types of solar system configurations for residential solar are: grid tied solar, hybrid grid tied, and off-grid.

2.2 System Coupling and Wiring

2.2.1 AC Solar System Coupling

AC coupling is a solar interconnect topology in which a solar system and battery are connected on the AC side, rather than a direct DC connection from the solar panels to the battery, which would be a DC coupled system. In the AC coupled system, the output of the battery and solar panel is converted to AC with an inverter and then they are connected on a common AC line. The AC line then interfaces with the home's load to supply power.

One of the challenges with an AC coupled system, as demonstrated in Figure 3, is that there are two inverters, one for the solar system and one for the battery. The system in Figure 3 is a retrofit that is designed to integrate with existing residential solar systems to provide battery backup capabilities. When the utility grid is lost in an AC coupled system, the battery inverter must perform two tasks: disconnect the home from the utility grid, and provide a reference waveform for the solar inverter. Without the reference waveform, the solar inverter will not work, and this feature is what dictates a manual system restart if the battery goes offline.⁷

⁷ Lorenz, E. (2015, January). *AC or DC Coupled - What?* Retrieved from CivicSolar: <https://www.civicsolar.com/support/installer/articles/ac-or-dc-coupled-what>

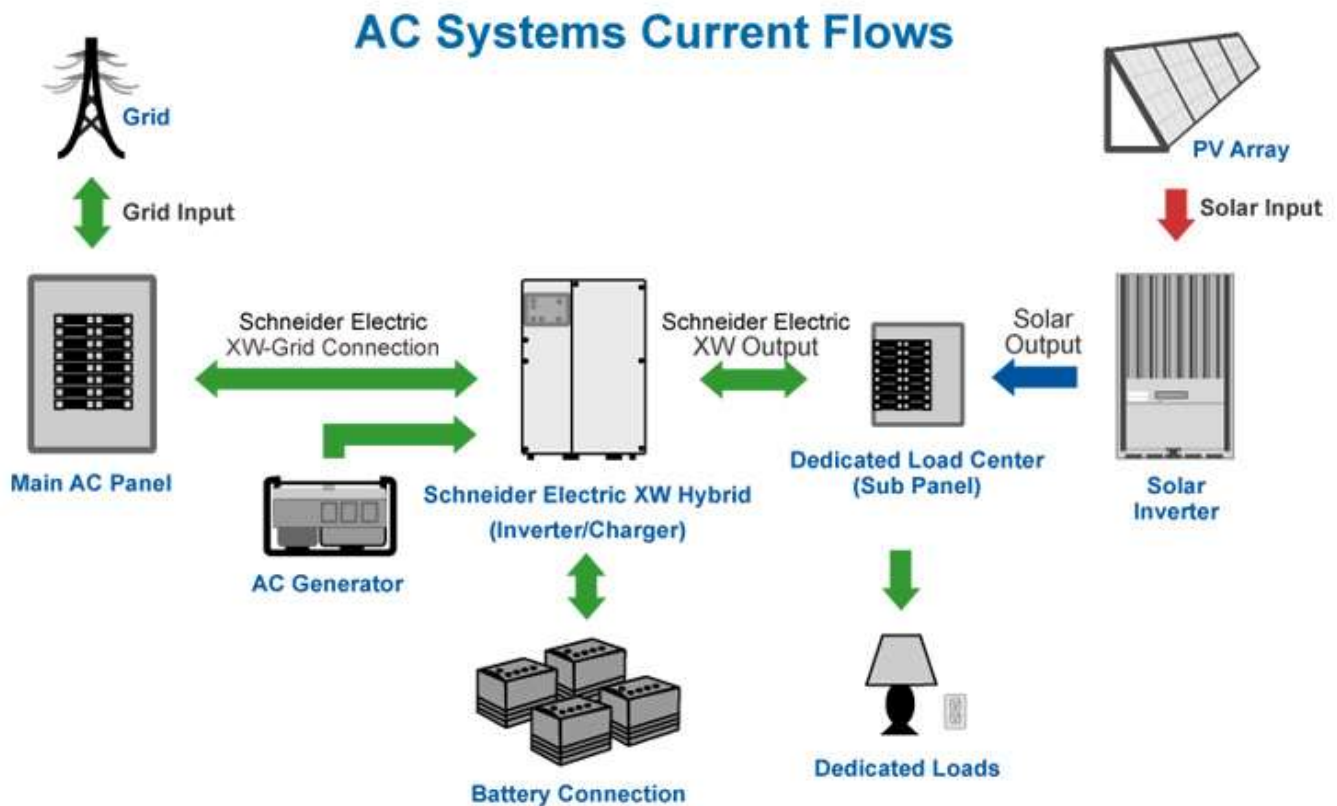

Figure 3. AC Coupled System⁸

2.2.2 DC Solar System Coupling

In a DC coupled solar system, batteries are connected to the PV panel's DC output, which then connects to an inverter that then feeds AC power into a home. An example of a DC coupled system can be found in Figure 4 as well as Figure 10. The solar panel's output is maximized via maximum power point tracking (MPPT) that then feeds the battery charge controller and then the loads through the inverter. Maximum power point tracking is a feature of most inverters or power optimizers that changes the DC voltage so that on the V-I power curve, the solar system will output at the point of maximum power. See Appendix J for more information on how MPPT works. When utility grid power is lost, the inverter can then transfer the load to a secondary sub-panel ensuring that power still flows while disconnecting from the grid.⁹ DC coupled systems are generally less expensive because they do not require a second inverter. An example of a battery in a DC coupled system would be the Tesla Powerwall in Section 2.5.2, which is connects directly to the solar panel output and the panels are used to charge the Powerwall directly.

⁸ Schneider Electric. (2016). *AC Systems Current Flows* [Online image]. Retrieved March 19, 2017 from <http://www.amerescosolar.com/sites/default/files/ac-battery-backup-diagram.jpg>

⁹ Lorenz, E. (2015, January). *AC or DC Coupled - What?* Retrieved from CivicSolar: <https://www.civicsolar.com/support/installer/articles/ac-or-dc-coupled-what>

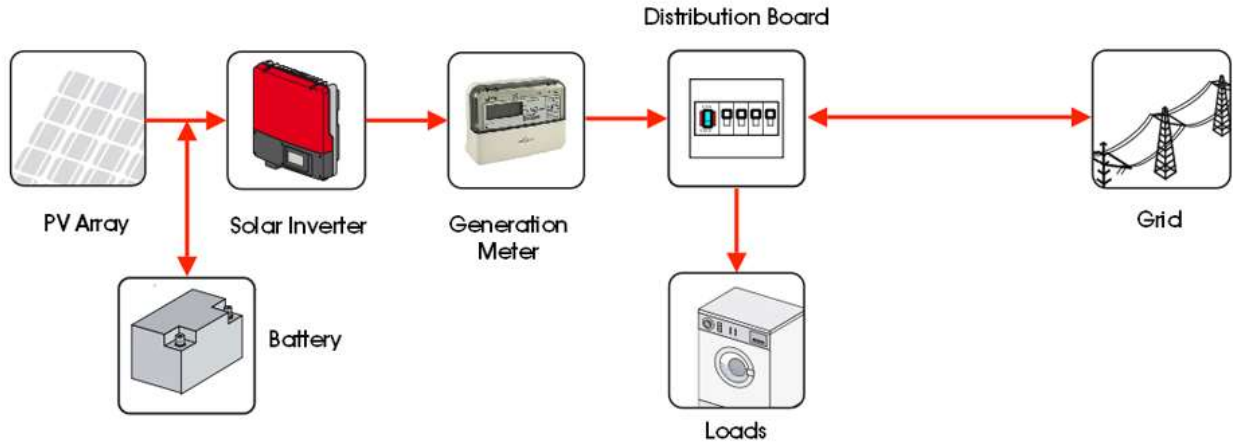

Figure 4. DC Coupled Solar System¹⁰

2.2.3 Split Phase Power

In the typical home, the utility company will provide split phase power to the house from a center tap transformer which is supplied by tapping a single-phase distribution line. This is accomplished by using a center tap transformer to create two phases for a home, which is demonstrated in Figure 5. Starting at the distribution transformer on the pole, a single phase is split to produce 120/240V AC split phase power. Figure 5 shows a center-tap transformer in which the voltage across two output lines is 240V AC. The center of the output transformer winding is tapped to serve as a zero-volt reference for each of the output lines and when an output line is referenced to the center tap or neutral, the voltage is 120V AC (the split phases). The center tap or neutral is generally non-current carrying. These two lines 120V lines are 180 degrees out of phase with respect to each other, and are used to create 240V for large appliances in a house.¹¹

¹⁰ Wind & Sun. (2017). *Grid Connect System with Battery Storage*. Retrieved from Wind and Sun: <http://www.windandsun.co.uk/information/types-of-system/grid-connect-system-with-battery-storage.aspx>

¹¹Sharma, V. (2012, August 01). *120 / 240 VAC Single Split Phase & Multi-Wire Branch Circuits*. Retrieved from SamlexAmerica: <http://www.samlexamerica.com/support/documents/WhitePaper-120240VACSingleSplitPhaseandMultiWireBranchCircuits.pdf>

Household distribution transformer

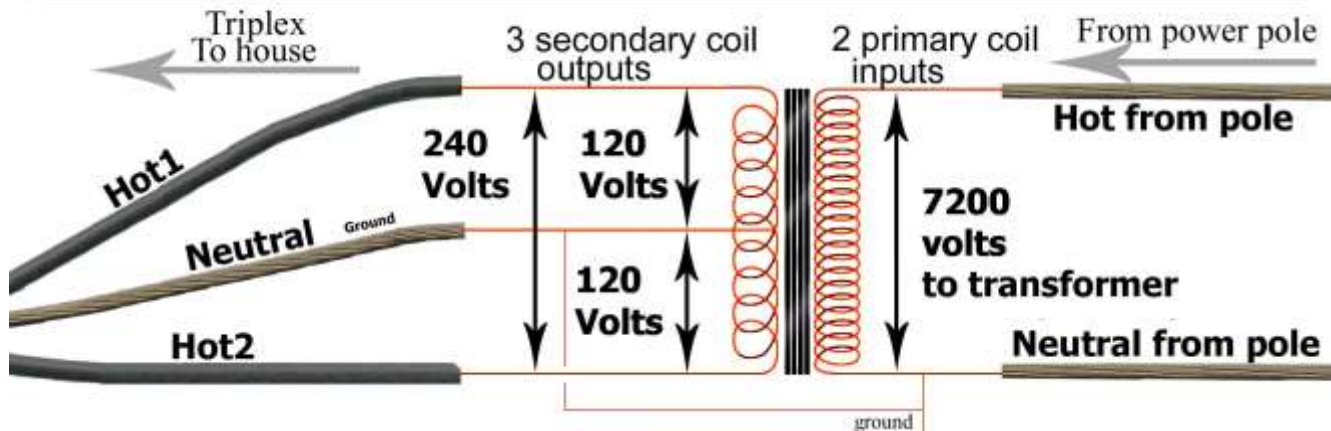

Figure 5. Utility Distribution Transformer and Split Phase Power¹²

2.2.4 Home Grounding System

The purpose of the home grounding system illustrated in Figure 6 helps to prevent electrical shocks to electricians and the homeowner. Article 250 of the National Electric Code (NEC) specifies the requirements for a grounding system. The earth grounding system in a home connects the breaker box to water pipes and then to a ground rod or ring as a noncurrent carrying system.¹³ The ground connection from the breaker box may also connect directly to a ground rod or ground ring as well. In the event of a fault or lightning surge, current is shunted to the earth through the ground system.

¹² Haynes, G. (n.d.). *Inside household distribution transformer*. Retrieved 2017, from See inside main breaker box: <http://waterheatertimer.org/See-inside-main-breaker-box.html>

¹³ Biesterveld, Jim. (2011). *GROUNDING AND BONDING NATIONAL ELECTRICAL CODE ARTICLE 250* [PowerPoint slides]. Retrieved from <http://fyi.uwex.edu/mrec/files/2011/04/W4.-Biesterveld-NEC-grounding-MREC2010.pdf>

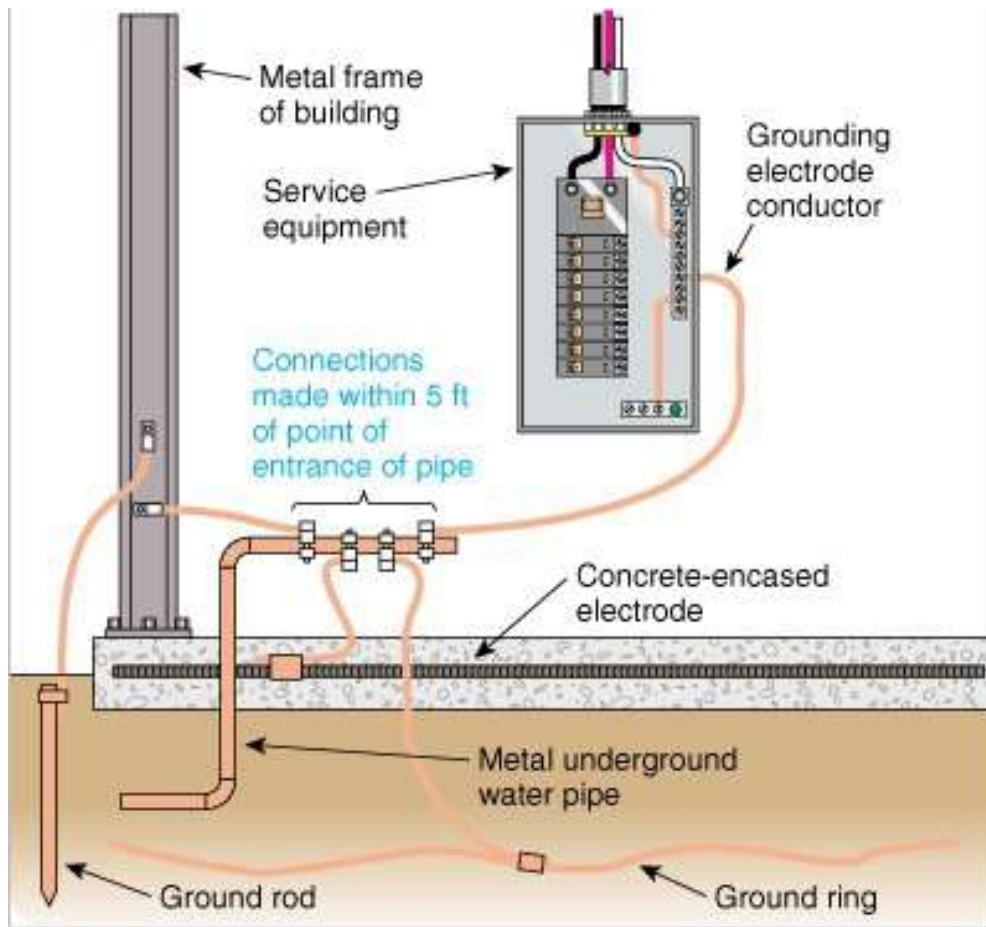

Figure 6. Home Grounding System¹⁴

2.3 Solar Inverters for Grid Tie and Off-Grid

2.3.1 Introduction to Inverters

A power inverter converts DC to AC and is used in a solar system to convert the DC output of solar panels to AC for use in a home. In principle, any DC to AC inverter uses transistors to control the flow of DC power through the use of pulse width modulation (PWM) by switching the transistors in the inverter on or off to create the desired waveform. Inverters can output a variety of different waveforms, such as a square wave, modified sine wave, or a pure sine wave as shown in Figure 7.

¹⁴Hester, D. (2013, 02 07). *Concrete encased Electrodes- UFER everybody*. Retrieved from North Central Washinton Home Inspections: <http://www.ncwhomeinspections.com/concrete+encased+electrode+system>

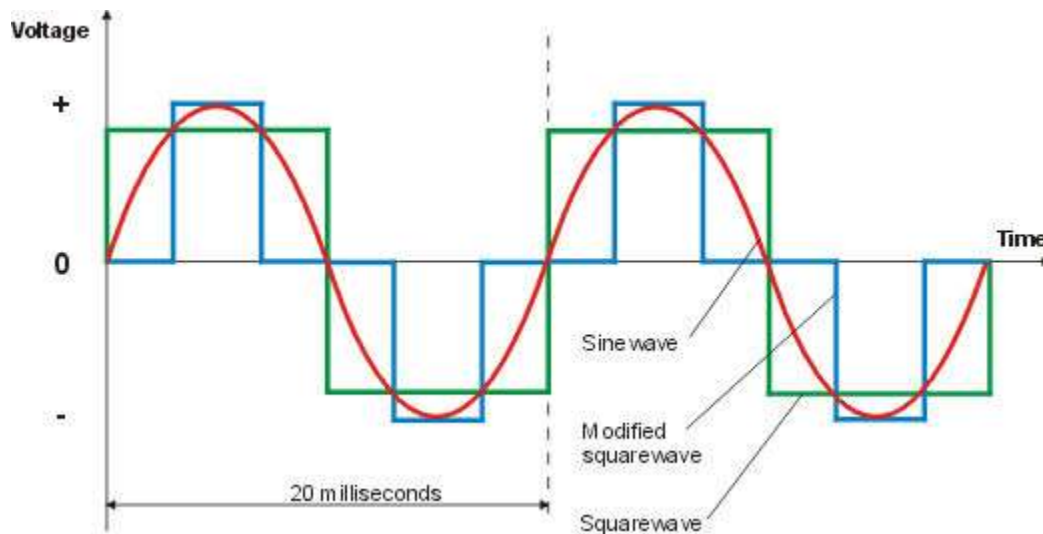

Figure 7. Inverter Waveform Outputs¹⁵

For a simple inverter, its output is a square wave or modified sine wave, but by using different filters and digital signal processing techniques, the square wave can be filtered into a sine wave.¹⁶ An H-bridge can be used to create a single AC phase, which is then passed through a transformer if higher output voltage is needed. Filters can then be used to further refine the output sine wave to produce a pure sine wave.¹⁷

2.3.2 Central Inverters

There are two main types of inverters for solar PV systems, distributed inverters (such as microinverters which are attached to each individual solar panel) and central inverters, with a single inverter for all the solar panels in the system. Central inverters in a solar system application are DC/AC converters that can convert all the available power from a home's solar system and output split phase 120V or single phase 240V into a home's breaker box, matching the grid's voltage waveform. Both central inverters and microinverters need to match their output voltage waveform to the grid's because if it is off by more than a few degrees, power cancellation occurs and eventual system failure would occur. The grid also provides the primary reference frequency for inverter operation as the inverter must match the grid's frequency. Central inverters typically range from 3-10KW, but can come in a variety of sizes. MPPT is standard in most central inverters, as is anti-islanding protection. Anti-islanding protection is required in central inverters to prevent them from back feeding power into the distribution lines during a power outage to avoid injuring line workers. For off-grid applications, central inverters do not need anti-islanding protections as they would prevent proper inverter operation. There are also limitations to the efficiency of MPPT on central inverters as the MPPT is functioning across the whole solar system and not just an individual PV module. For an example of a central inverter and sample specifications, see Appendix I.

¹⁵ Nasir, S. Z. (2012, November 5). *Pure Sine Wave Inverter Design With Code*. Retrieved from The Engineering Projects: <http://www.theengineeringprojects.com/2012/11/pure-sine-wave-inter-design-with-code.html>

¹⁶ Grabianowski, E. (2009, February 10). *How DC/AC Power Inverters Work*. Retrieved from HowStuffWorks.com: <http://electronics.howstuffworks.com/gadgets/automotive/dc-ac-power-inverter2.htm>

¹⁷ Worden, J., & Zuercher-Martinson, M. (2009, May). *How Inverters Work*. Retrieved from SolarPro: <http://solarprofessional.com/articles/products-equipment/inverters/how-inverters-work>

2.3.3 Microinverters

Microinverters are DC to AC inverters that are designed to attach to each individual solar PV panel and are meant to be connected to adjacent microinverters in a solar system. They allow for a decentralized system of solar inverters rather than a single central inverter. This allows each inverter to have a lower power rating and system failure can be avoided if an inverter fails. When a PV modules is shaded, each microinverter will perform MPPT limited to their individual module leading to more optimized power production from each module, improving the overall system power output versus a central inverter. Even without shading effects, microinverters optimize the solar system power output as much as 2-3% more when compared to a central inverter with string optimizers.¹⁸

While microinverters provide several advantages, they are generally harder to replace and repair.¹⁹ When a central inverter fails, the inverter can be easily repaired or replaced by a technician because it is relatively easy to access. However, when a microinverter fails, the solar panel must be removed from its mounting and the inverter must be replaced, creating additional work and cost. Since the microinverter must be mounted outdoors behind the solar panel, they also experience higher rates of failure due to weather conditions and heat generated by the solar panels. In addition, they do not have uniform rates of failure.



Figure 8. Enphase M190 Microinverter²⁰

Microinverters (such as the one shown in Figure 8) need an AC grid as an input reference, otherwise they cannot operate as all the microinverters need to follow a reference frequency.²¹ The Enphase M190 Microinverter in Figure 7 has a power output of 190W at both 208V or 240V with a nominal frequency of 60Hz with a frequency range of 59.3Hz to 60.5Hz.

¹⁸ Jacobson, N., Donovan, M., & Forrest, J. (2013). Enphase Energy. PV Evolution Labs. Retrieved from https://enphase.com/sites/default/files/PVEL_Study-on-EE-vs-SolarEdge.pdf

¹⁹ Energysage. (n.d.). *Advantages & disadvantages of micro-inverters & power optimizers*. Retrieved from Energysage: <https://www.energysage.com/solar/101/microinverters-power-optimizers-advantages-disadvantages/>

²⁰ Enertek Supply. (2011). *Enphase M190 - Ontario FIT*. Retrieved from Enertek: <http://www.enerteksupply.com/enphase-m190.html>

²¹ Enphase Energy. (2014, January 17). *AC Coupling of Enphase Microinverters to Battery Based Systems*. Retrieved from Enphase Energy: https://enphase.com/sites/default/files/Enphase_Application-Note_AC-Coupled-Battery-Based-Systems.pdf

2.4 System Layouts for Hybrid Grid Tied Solar With Batteries

Hybrid grid tie solar systems are those that are connected to a utility grid and can function during a power outage by disconnecting from the utility grid. A hybrid inverter can function with multiple power inputs from solar systems and batteries, which allows for energy to be stored and used at various times.²² The battery however is optional in the system and is not required. A hybrid inverter eliminates the need for a second inverter for the battery system and the major advantage of hybrid systems is that they can provide a battery backup for backup power.

2.4.1 Hybrid Grid Tie System with Battery Backup

Grid tie systems with battery backup or generator backup capabilities can be implemented in several different ways. Figure 9 shows one method of configuring a hybrid grid tie system with battery backup in which the solar system supplies a central solar inverter. The solar inverter is then connected to a subpanel of essential loads which can supply preselected circuits in the home. A battery and divisionary load is connected to the battery inverter panel which has disconnects in order to island the home during a power outage. The battery inverter supplies the lost AC waveform in order to keep the solar system online.

The sub-panel serves as the breaker box for the “essential” circuits connected to a battery bank or an attached generator. When installing the system, the homeowner must decide which circuits they want powered by the sub-panel when the electrician installs the system. The battery inverter acts as a charge controller which controls the charging of the battery bank and the power flow to and from the batteries in the event of an outage to the sub-panel. If the current draw from the battery bank is too high, the charge controller will shut down to protect the batteries and wires from overheating past their thermal limits.

The battery inverter can include a battery monitor and load balancer, depending on the manufacturer, and the inverter plugs connects to the battery bank. The battery bank then helps provide power to the AC sub-panel when the solar PV panels are insufficient to meet demand. The inverter also connects to the main breaker panel and can serve as a conduit for the power from the solar system to the rest of the house when the grid is online. To measure power flows in both directions, a bidirectional meter is used.²³

²² Zipp, K. (2015, January 14). *How are hybrid inverters used in solar projects?* Retrieved from Solar Power World: <http://www.solarpowerworldonline.com/2015/01/hybrid-inverters-used-solar-projects/>

²³ SEIA. (2012). *Net Metering*. Retrieved from Solar Energy Industries Association: <http://www.seia.org/policy/distributed-solar/net-metering>

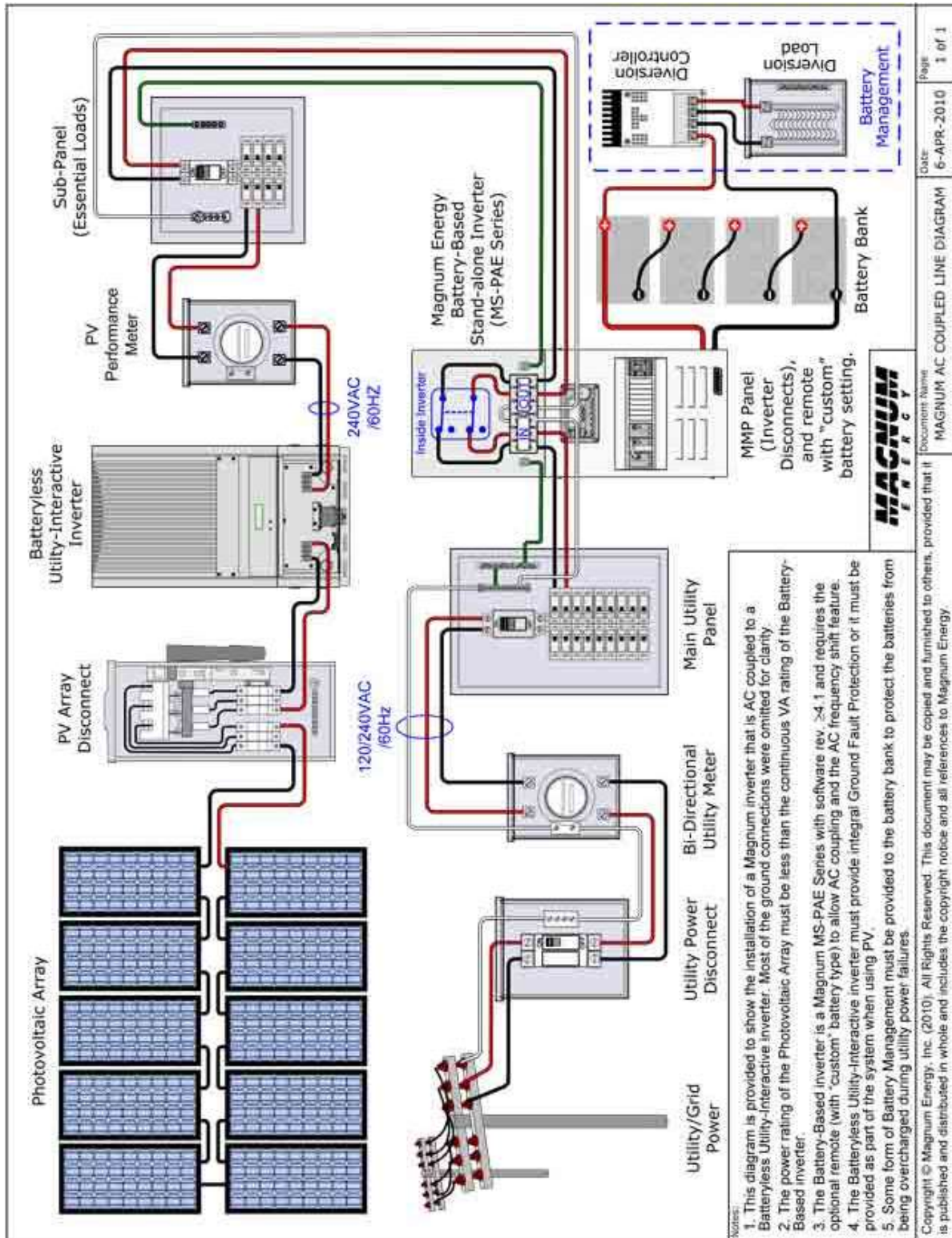

Figure 9. A Grid-tie System with Battery Backup²⁴

²⁴Magnum Energy. (2010, May 1). *MAGNUM AC COUPLED LINE DIAGRAM*. Retrieved from Magnum Energy: <http://www.magnum-dimensions.com/sites/default/files/MagArchive/Magnum-AC-Coupled-Line-Diagram-1-May-2010.pdf>

2.4.2 SMA Technologies Hybrid Grid Setup

SMA Solar Technology manufactures on-grid and off-grid solar system solutions designed to upgrade residential home energy systems and function without a utility connection. For hybrid grid solutions, a sample system wiring diagram for an AC coupled system is shown in Figure 10. The central points of the system are the PV inverter and the Sunny Island battery inverter. Connections to two main sources are offered in the hybrid grid tie system. These main sources are a diesel generator or a utility grid connection can be used to supply the home. A transfer switch is used to switch between these two sources as necessary. However, in off-grid mode, the utility grid connection is not available and power would be provided by the batteries, solar system, and optionally a generator.

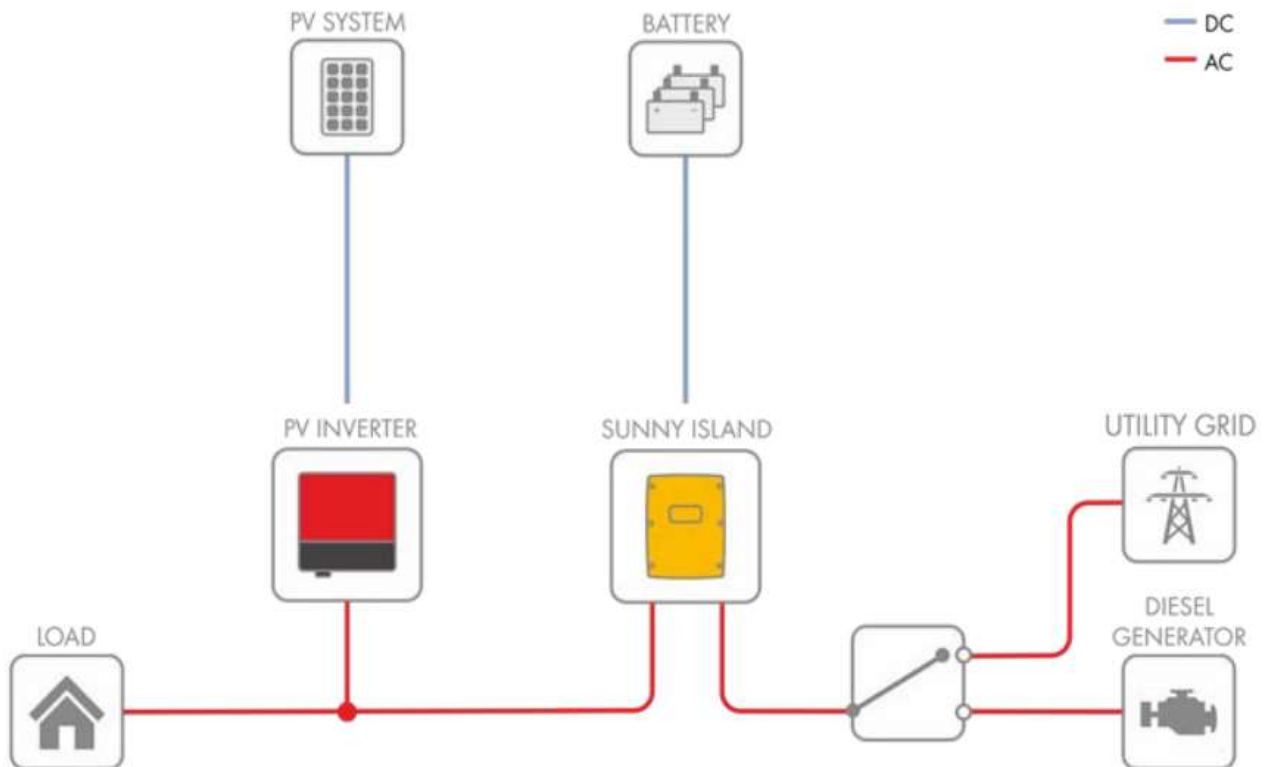

Figure 10. Sample SMA Grid-tie with Battery Backup Configuration²⁵

²⁵SMA Solar Technology. (2014, October 28). *Wiring Diagram Solar System Off Grid*. Retrieved from SMA: <http://www.sma-america.com/fileadmin/content/www.sma-america.com/home-systems/Documents/wiring-diagram-solar-system-off-grid.pdf>

2.4.3 SolarEdge

SolarEdge manufactures a family of products within its StorEdge hybrid solar system that can provide power during an outage using battery based storage.²⁶ The SolarEdge inverter acts as the central controller connecting a solar system, battery pack, loads, and meters. SolarEdge utilizes a DC coupled system for improved efficiency and to provide power in the case of grid failure. An example of a typical SolarEdge system with a solar inverter and battery backup can be seen in Figure 11.

The StorEdge system is designed to be compatible with a Tesla Powerwall or LG Chem battery to provide power during an outage. The control system also allows for the powering of preselected circuits during an outage or demand response in addition to load shaving during non-outages. Measurements are conducted with the SolarEdge Electricity Meter with on-grid installations to provide information on whether to store electricity or export to the utility. The meter will also help measure how much energy is left in the battery and help reduce general electricity consumption.

The power optimizers in the system help to optimize the power output of the solar panels using MPPT. They also monitor the performance of the solar system and relay that information back to the homeowner.²⁷ One of the differences between the SolarEdge system and the SMA Technologies system is that the SolarEdge system uses a DC connection between the battery and solar system versus the SMA system which connects the batteries through a second inverter on the AC side with AC coupling.

2.4.3.1 The SolarEdge Inverter

SolarEdge manufactures a single phase solar inverter for use with residential and commercial solar installations. The SolarEdge single phase StorEdge hybrid inverter in Figure 12 features two input connections, battery and PV and can operate in backup mode. The frequency tolerances for the inverter are 60Hz nominal, plus or minus 5Hz. In both normal operating mode and backup mode, the nominal rated power output is 5000VA at 220/230V AC. The SolarEdge inverter features internet connectivity via RS485, ethernet, or wirelessly with a ZigBee in Figure 13 or Wi-Fi.²⁸

²⁶ SolarEdge. (2016). *StorEdge™ Products for On-grid Applications & Backup Power*. Retrieved from SolarEdge: <http://www.solaredge.com/us/products/storedge#/>

²⁷ SolarEdge. (2016). *Power Optimizer*. Retrieved from SolarEdge: <http://www.solaredge.com/us/products/power-optimizer#/>

²⁸ SolarEdge. (2017, March). *SolarEdge Single Phase StorEdge Inverter*. Retrieved from StorEdge: https://www.solaredge.com/sites/default/files/se_storedge_inverter_datasheet_eng.pdf

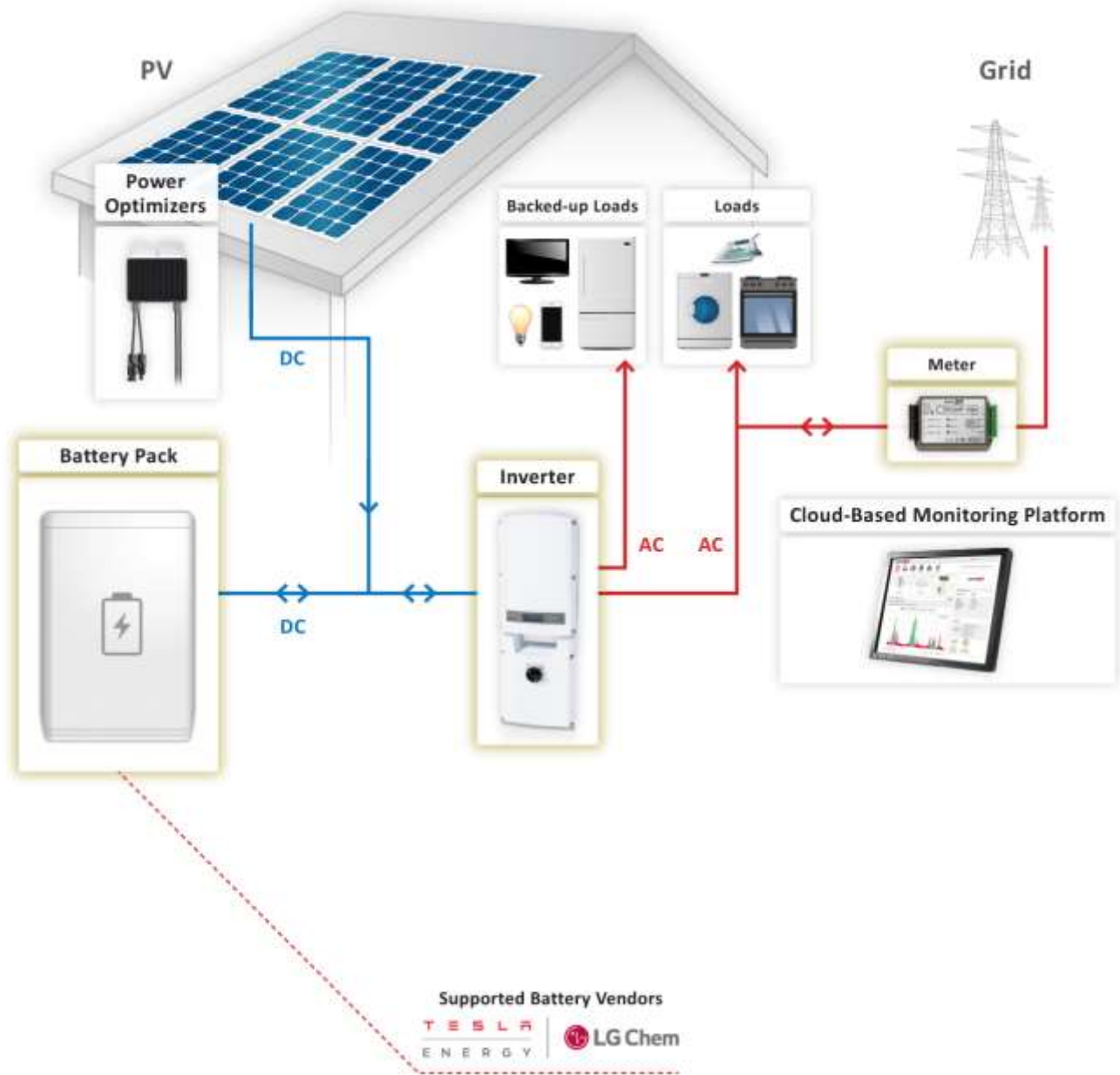

Figure 11. SolarEdge StorEdge Solutions²⁹

²⁹ SolarEdge. (2017). *The SolarEdge StorEdge Solution*. Retrieved from SolarEdge: <https://www.solaredge.com/us/solutions/grid-backup#/>



Figure 12. SolarEdge StorEdge Single Phase Inverter



Figure 13. SolarEdge Wi-Fi Communication Solution³⁰

³⁰ SolarEdge. (2016). *SolarEdge Home Gateway Kit*. Retrieved from SolarEdge: <https://www.solaredge.com/us/products/communication/solaredge-home-gateway-kit/>

2.4.4 Schneider Electric

Schneider Electric manufactures a residential hybrid grid-tie solar system with a battery backup shown in Figure 14. In the hybrid DC coupled system the Conext XW+ inverter serves as the central junction point accepting feeds from the grid (main AC panel), and solar and batteries while distributing power to the AC subpanel.³¹ During an outage, power is provided to the AC subpanel, which is isolated from the main AC panel. Hybrid grid tie systems such as the one in Figure 14 are also capable of load peak shaving and other utility interactive mechanisms that can help make adopting solar PV easier for the grid system. Like Figure 11, Figure 14 follows an almost identical architecture.

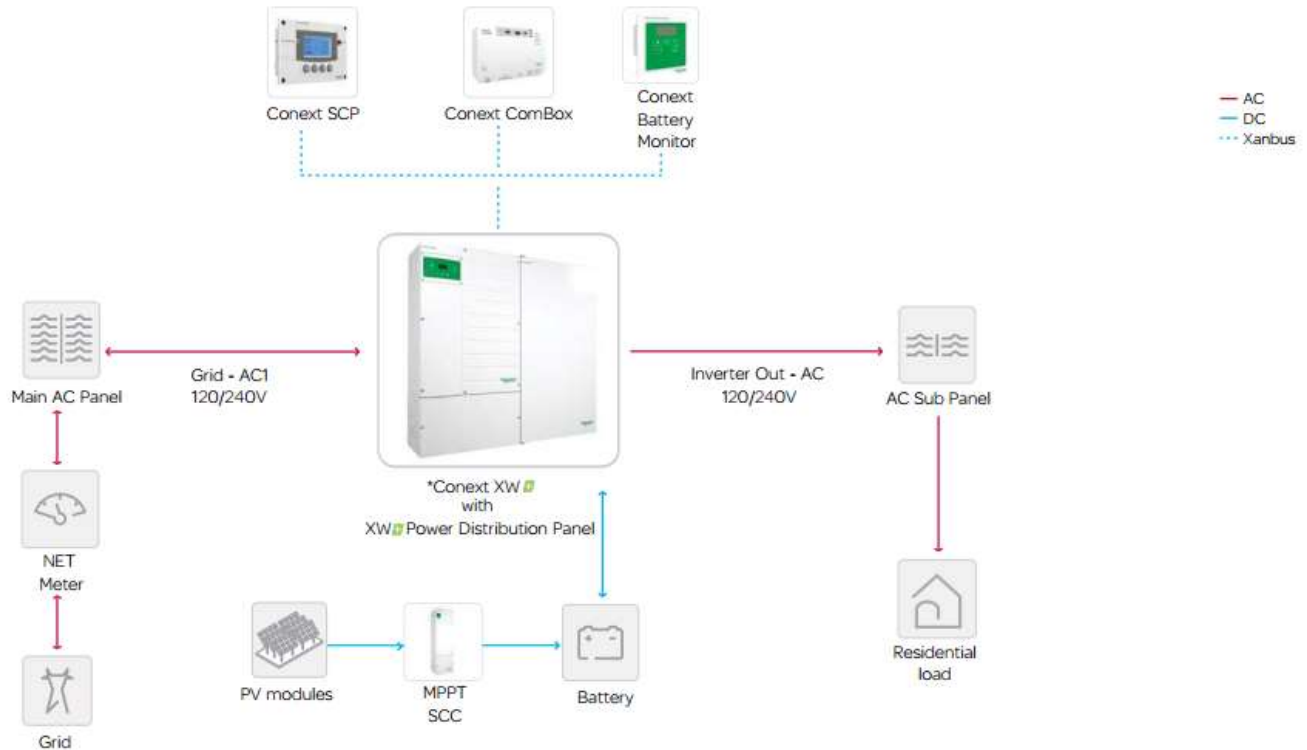

Figure 14. Conext XW Hybrid Grid Tie System³²

³¹Schneider Electric. (2016, October 17). *Grid-tie, off-grid solar and backup power solutions*. Retrieved from Schneider Electric: <http://cdn.solar.schneider-electric.com/wp-content/uploads/2014/04/Grid-tie-Off-grid-Solar-and-Backup-Power-Solutions-Brochure2.pdf>

³²Schneider Electric. (2014). *Residential, self consumption*. Retrieved from Schneider Electric: http://cdn.solar.schneider-electric.com/wp-content/uploads/2014/03/Residential_self-consumption_r1SW.pdf

2.4.4.1 Schneider Electric Inverter

The Schneider Electric Conext XW+ 120/240V Inverter supports single or three phase systems from 7kW to 102kW with a multiple inverter array system for both off-grid and on-grid applications. Generators and the grid are potential input connections along with a supporting battery system. The output voltage is 120/240V with a +/- 3% tolerance and the output frequency range is 59.4 to 60.4 Hz with a +/- 0.05Hz tolerance. For off-grid support, frequency control is offered, along with other features such as prioritizing power sources, load shaving, and selling excess power to the grid. The Schneider Electric Inverter can be seen in Figure 15.



Figure 15. Schneider Electric Conext XW+ Solar Hybrid Inverter System³³

³³ Schneider Electric. (2015). *Conext XW hybrid inverter/charger*. Retrieved from Schneider Electric: http://cdn.solar.schneider-electric.com/wp-content/uploads/2015/10/Conext-XW-Datasheet_ENG.pdf

2.5 Batteries

2.5.1 ABB REACT Battery

The ABB REACT in Figure 16 is a combined solar inverter and 2 kWh battery. It is a 230V, 50 Hz single phase system with additional MPPTs for solar systems designed for European use. To measure the production of the solar system, energy meters are integrated into the system along with an additional load manager function. For overvoltage protection, there are varistors, which will act as an open circuit during an overvoltage event. For remote monitoring, the ABB REACT is equipped with a Wi-Fi connection and a user interface consisting of a mobile app, user display panel, or web page.³⁴ During an outage, the battery can support an AC output with an automatic or manual restart. The length of time the battery will last depends on the active loads.

REACT-3.6/4.6-TL



Figure 16. ABB REACT Battery and Inverter³⁴

³⁴ ABB. (2016, November 22). *REACT-3.6/4.6-TL 3.6 to 4.6 kW*. Retrieved from ABB PV + Storage: https://library.e.abb.com/public/708ebdcf595a41739b853fd434c8786f/REACT-3.6-4.6_BCD.00386_EN_RevG.pdf

2.5.2 Tesla Powerwall

The Tesla Powerwall 2 battery, shown in Figure 17, has a 13.5kWh capacity and can provide 7kW peak power and 5kW continuously and features an integrated inverter.³⁵ The Powerwall can both serve as a backup to the grid in the event of an outage and power the entire home or select circuits in conjunction with solar panels. As a storage system, it can store power from the solar system for use at night or to use off-grid. The Tesla Powerwall will charge during the day when home energy demand is low, and solar production is high. The stored power can be used during peak consumption hours which are not the peak production hours. The solar system will still need to be net metered to measure solar system production for the utility.



Figure 17. Tesla Powerwall 2³⁶

³⁵ Tesla. (2017). *Powerwall*. Retrieved from Tesla: <https://www.tesla.com/powerwall>

³⁶ Tesla. (2017). *Powerwall* [Online image]. Retrieved March 5, 2017 from https://i1.wp.com/electrek.files.wordpress.com/2016/10/press_powerwall2_header-e1486062705250.png

The Powerwall connects to the solar system and can either be AC or DC coupled. The batteries only draw or produce power when either: instructed to by a controller via a communications port or when the Powerwall senses the home loads are greater than power generation. The integrated inverter then converts DC power to AC power for use by the home with an energy meter to measure solar production and home power usage. To power the home during an outage, a backup panel is needed to switch the power supply from the grid to the solar panels and battery. The roundtrip efficiency for the Tesla Powerwall is 89% for AC coupling and 91.8% for DC coupling, making it an efficient battery storage system.³⁷

³⁷ Lambert, F. (2016, October 28). *Tesla Powerwall 2 is a game changer in home energy storage: 14 kWh w/ inverter for \$5,500*. Retrieved from Electrek: <https://electrek.co/2016/10/28/tesla-powerwall-2-game-changer-in-home-energy-storage-14-kwh-inverter-5500/>

2.6 Charge Controllers

2.6.1 Battery Charge Controllers

Battery charge controllers are devices used to prevent a battery from overcharging and prevent unintentional discharge current through the attached solar panels at night. At night, the panels will draw some current from the battery if sufficient protection is not built into the battery charge controller. The night time system losses can be prevented with a transistor or relay switch that opens at night. Preventing the batteries from overcharging is the main purpose of any battery charge controller because overcharging can damage the battery and eventually cause it to catch fire.³⁸

2.6.2 Solar Charge Controllers and MPPT

MPPT charge controllers control the output voltage and current of solar panels to maximize the amount of power delivered under varying conditions.³⁹ MPPT helps to improve the solar system performance and can be applied to the system as a whole or to individual panels. Varying conditions can include cloud cover shading the panels, tree branches casting shadows on panels, or the changing angle of the sun. When a panel is under these varying conditions a MPPT controller will output a voltage with a variable current delivering maximum power instead of operating at the standard panel voltage output.⁴⁰ As a day progresses, the irradiance and other factors change, causing the solar panels to produce less power, requiring the MPPT to alter voltage levels to maximize power production. The MPPT acts as a DC to DC converter to modulate the solar panel array output which reduces the losses from the panel.⁴¹

2.7 Automatic Transfer Switches

An automatic transfer switch (ATS) as illustrated in Figure 18 allows for selected grid-tie circuits to switch from main power to a secondary power source (solar or generator) in the event of a grid outage. The ATS (black box in Figure 18) has two inputs, the utility grid and a generator (or equivalent source). The transfer switch is connected to both the home circuits via the breaker box and the generator while offering a central connection point to the utility. The ATS is required by the National Electric Code (NEC) for a standby generator that automatically switches on during an outage, and it must be installed next to the breaker panel in a home. The switch transfers the power source from the utility grid-tie to an alternative source to ensure both sources cannot be active at the same time to prevent power from flowing back into the grid during an outage and injuring line workers.

³⁸ Dankoff, W. (1999). *What is a Charge Controller?* Retrieved from Blue Sky Energy: http://www.blueskyenergyinc.com/reviews/article/what_is_a_charge_controller

³⁹ Northern Arizona Wind & Sun. (2013). *All About Maximum Power Point Tracking (MPPT) Solar Charge Controllers.* Retrieved from Northern Arizona Wind & Sun: <https://www.solar-electric.com/mppt-solar-charge-controllers.html/>

⁴⁰ Cullen, R. (2009, March 25). *What is Maximum Power Point Tracking (MPPT) and How Does it Work?* Retrieved from Blue Sky Energy: http://www.blueskyenergyinc.com/uploads/pdf/BSE_What_is_MPPT.pdf

⁴¹ Bas, L. (2011, March). *How do MPPT charge controllers work?* Retrieved from CivicSolar: <https://www.civicsolar.com/support/installer/articles/how-do-mppt-charge-controllers-work>

Both manual and automatic switches exist with automatic switches allowing for an uninterruptible power supply (UPS) by automatically switching to generator power during an outage.⁴² An ATS uses a motor operator to switch the breakers in the event of an outage, and it is protected with a separate fuse.

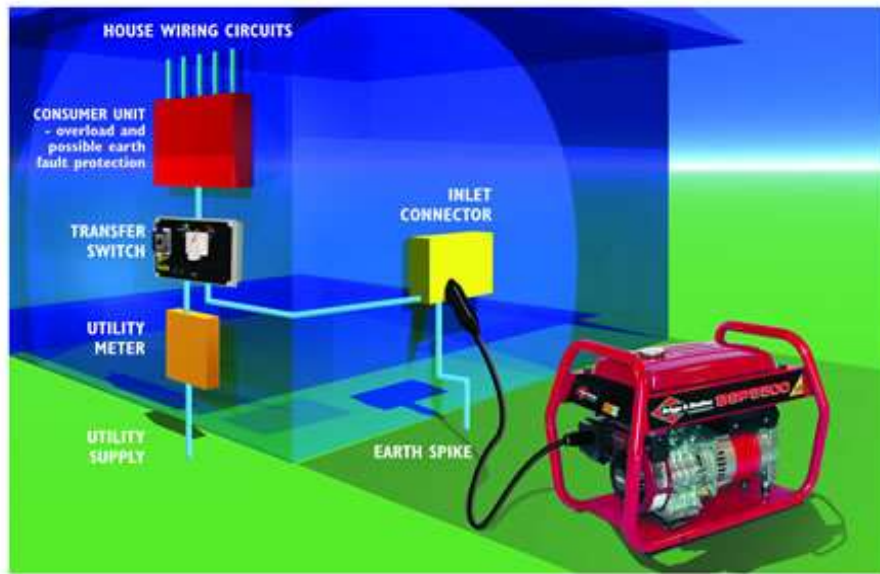

Figure 18. High Level Generator and Transfer Switch Setup⁴³

To operate, an ATS must first detect an outage or power quality issue to bring the standby generator online. Once the generator is running with a stable voltage and frequency, the load is shifted from the utility power to the generator. The circuits powered by the ATS are chosen in advance by the homeowner when an electrician installs the ATS. The ATS ensures that the sources cannot be paralleled in operation, preventing power feedback into the grid.

To detect an outage or power quality issue, both voltage and frequency are usually monitored with set points enabled so if a certain voltage drop or rise is detected; the power source is transferred to a standby generator. When an outage is detected, the transfer switch is programmed with a variable time delay to ensure that the outage or power quality loss is not momentary and allows the standby generator time to come online. The variable time delay is usually between zero to six seconds.

Fault detection on the incoming power line may be achieved with overcurrent relays or current transformers. To protect the ATS, surge protection is needed both before and after the ATS as the switch action can generate transients, which can damage equipment past the ATS.⁴⁴

⁴² Honda. (2012). *Connecting your generator to your home*. Retrieved from Honda Power Equipment: <http://powerequipment.honda.com/generators/connecting-a-generator-to-your-home>

⁴³ Jefferson Energy Cooperative. (2014). *Using Generators*. Retrieved from Jefferson Energy Cooperative: <http://www.jec.coop/content/using-generators>

⁴⁴ Moraff, P. (2016). *ATS (AUTOMATIC TRANSFER SWITCH) APPLICATION*. Retrieved from MCG Surge Protection: <http://www.mcgsurge.com/ats-automatic-transfer-switch-application/>

To avoid paralleling sources, the backup source is disconnected before switching back to the primary source. There is also an overcurrent sensor on the alternate source in the event the alternate source experiences a fault.⁴⁵ The operating states for a sample ATS is shown in Figure 19.

The first state in Figure 19 shows that the critical load is supplied by the preferred source (such as a utility connection). The alternate source (such as a battery bank) is connected to the open switch, which prevents it from being able to turn on when not needed. When the power of the preferred source is lost, the switch connecting it to the load is opened in state two. During state three, the alternate source switch is closed to deliver power to the critical load. State four occurs once the power is turned back on and the utility grid is restored. The next step in state five is to open the alternate source switch, disconnecting both sources to avoid paralleling the sources. Finally, the preferred source switch is closed, connecting the utility grid back to the critical load (the home).

⁴⁵ S&C Electric Company. (2014). *Solutions for Automatic Source-Transfer*. Retrieved from S&C Electric Company: <https://www.sandc.com/en/solutions/automatic-source-transfer/>

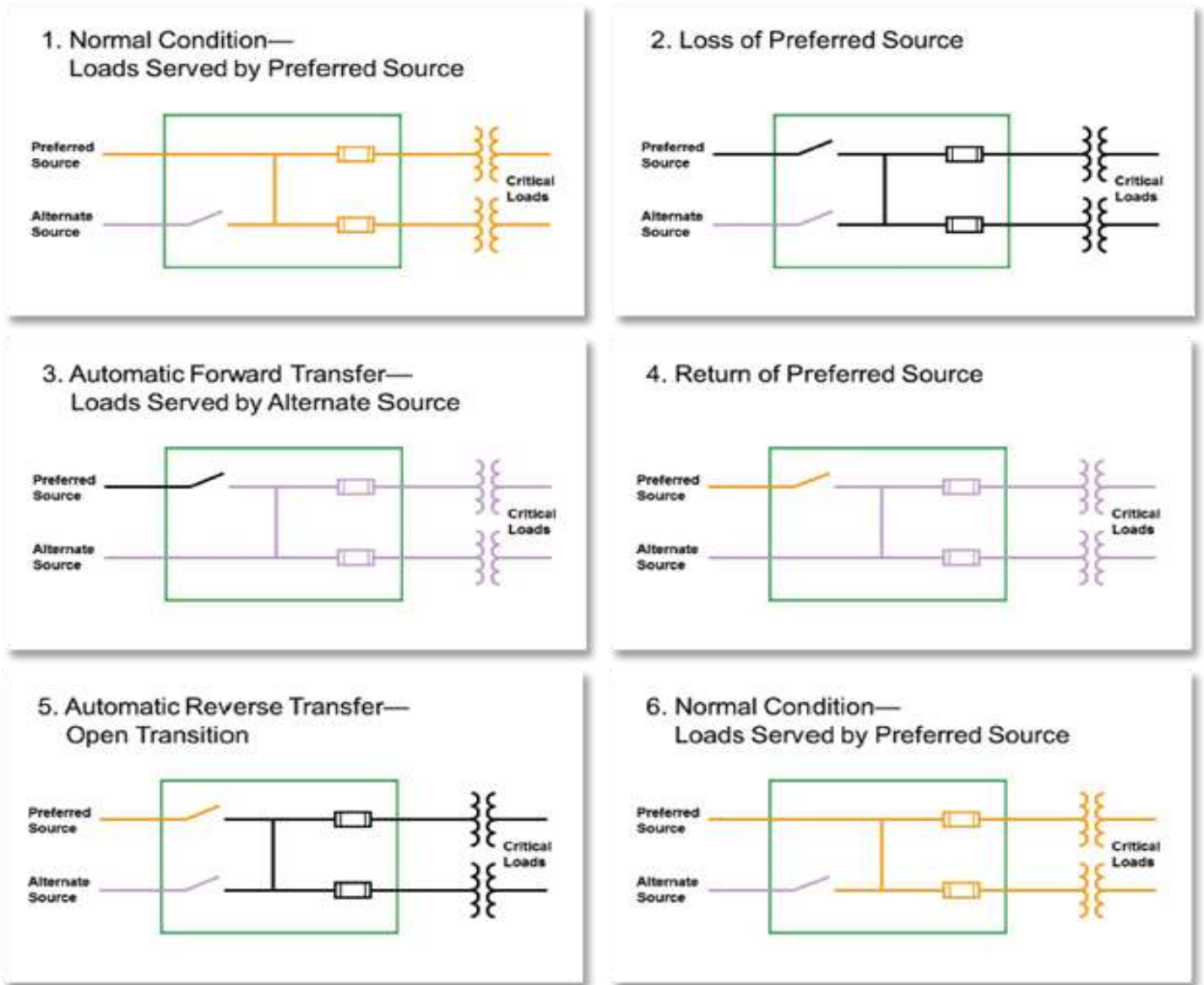

Figure 19. S&C Source Transfer Operating States⁴⁶

⁴⁶ S&C Electric Company. (2014). *Solutions for Automatic Source-Transfer*. Retrieved from S&C Electric Company: <https://www.sandc.com/en/solutions/automatic-source-transfer/>

2.8 Islanding Detection Methods

Current solar grid tie systems must have anti-islanding protection built in per UL standard 1741. There are several different methods for detecting a grid outage such as transient detection for voltage, frequency, or current.⁴⁷ The purpose of these outage detection methods or “islanding detection methods” is to force the solar inverter to immediately shut down during an outage.

When abnormal grid conditions are detected, an isolator switch (potentially an ATS) needs to fully disconnect the house from the grid, satisfying the NEC and UL 1741 standard. Inverter generators may need low-voltage-ride-through (LVRT) and frequency-ride-through (FRT) when switching to island mode or even as the utility grid is failing as specified by the utility. In the low-voltage-ride-through mode, when the grid voltage rises or falls beyond its limits for a short amount of time, the inverter must stay connected to help maintain grid stability. Inversely, LVRT can occur with high voltages as well, and in Hawaii, the inverter only shuts down when the voltage passes 120% or 113%-120% for more than 0.9 seconds, whichever comes first. FRT is similar to the voltage-ride-through in which the inverter must stay online during short-term frequency excursions beyond nominal.⁴⁸ Depending on utility requirements, this feature may be necessary to assist grid stability during frequency excursions by forcing the solar generation to remain online. The inverter will then monitor utility line voltage or frequency to detect a reactivation of the grid and then reconnect. The solar inverter can only reconnect and synchronize the frequency to the utility grid to begin power production five minutes after the grid comes back online per utility regulations.⁴⁹

To synchronize with the utility grid, an inverter can generate an AC output waveform using PWM to match the utility grid waveform. Combined with active sensing, the inverter will continually match and adjust its frequency to the utility grid. A phase-lock loop (PLL) can then be used to match the inverters waveform output with the utility grid, helping to further synchronize the PWM waveform. A relay circuit will then break the connection with the utility grid in the event of a detected outage or fault.⁵⁰ In order to detect frequency excursions past the phase lock loop reference, a zero-crossing detector is used which drives an output when the input passes the reference signal. The PLL serves as the reference signal input.⁵¹

⁴⁷ De Rooij, D. (2015, July 16). *Islanding: what is it and how to protect from it?* Retrieved from SinoVoltaics: <http://sinovoltaics.com/learning-center/system-design/islanding-protection/>

⁴⁸ Dyke, J. (2015, May 5). *Hawaiian grid requirements explained: interim ride through.* Retrieved from SMA: <http://www.smainverted.com/hawaiian-grid-requirements-explained-interim-ride-through/>

⁴⁹ Greacen, C., Engel, R., & Quetchenbach, T. (2013). *A Guidebook on Grid Interconnection and Islanded Operation of Mini-Grid Power Systems Up to 200 kW.* Berkeley: Lawrence Berkeley National Laboratory. Retrieved from http://www.cleanenergyministerial.org/Portals/2/pdfs/A_Guidebook_for_Minigrids-SERC_LBNL_March_2013.pdf

⁵⁰ Evanczuk, S. (2015, June 25). *Anti-Islanding and Smart Grid Protection.* Retrieved from Digi-Key: <https://www.digikey.com/en/articles/techzone/2015/jun/anti-islanding-and-smart-grid-protection>

⁵¹ Advanced Linear Devices. (2005). *Zero Crossing Detector.* Retrieved from Advanced Linear Devices: http://www.aldinc.com/pdf/cd_23004.0.pdf

Grid-tie inverters are generally not designed to provide AC power if the grid power is not present. To synchronize the inverter output to the utility grid, a phase-locked oscillator is used and during an outage, the phase-locked oscillator drifts out of tolerance signaling an outage event. If there is an outage, the phase-locked loop frequency will drift to zero as only the inverter is supplying power to the grid. Therefore, a limit is set, at which point when the phase-locked loop frequency drifts past the limit, the inverter shuts off. Once the outage ends, the PLL and the utility grid synchronize and solar power production resumes.⁵²

2.9 Switching Transients

In an off-grid home electrical system, the home grid will have to contend with various switching transients that would otherwise be absorbed by the utility grid. These switching transients occur when an inductive or capacitive load is switched on or off, causing power quality degradation. The transients may be either a voltage or current transient within two categories. The first category is an impulsive transient as shown in Figure 20, which is a sudden surge in power that is very damaging. In addition to transients from switched inductive/capacitive loads, lightning strikes will also cause an impulsive transient.

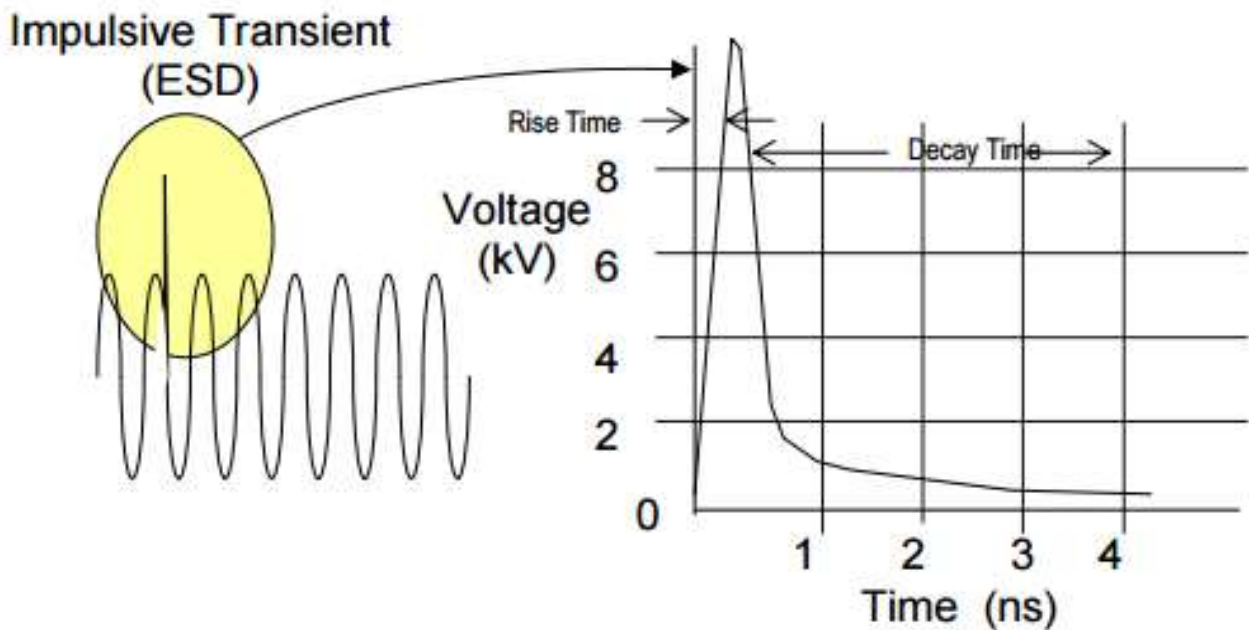

Figure 20. Impulse Transient⁶³

The other form of transients are oscillatory transients as demonstrated in Figure 21. These are caused by capacitive or inductive loads turning off and generally last a single cycle, which changes the steady state waveform. Surge protective devices and UPS's both serve as a protection against these types of transients along with a line reactor.⁵³

⁵² Meares, L. (2012, August 7). *Product How-To: Solar power anti-islanding and control*. Retrieved from EDN Network: <http://www.edn.com/design/systems-design/4391907/Product-How-To--Solar-power-anti-islanding-and-control>

⁵³ Seymour, J. (2012, May 4). *The Seven Types of Power Problems*. Retrieved from Schneider Electric: http://www.apc.com/salestools/VAVR-5WKLPK/VAVR-5WKLPK_R1_EN.pdf?sdirect=true

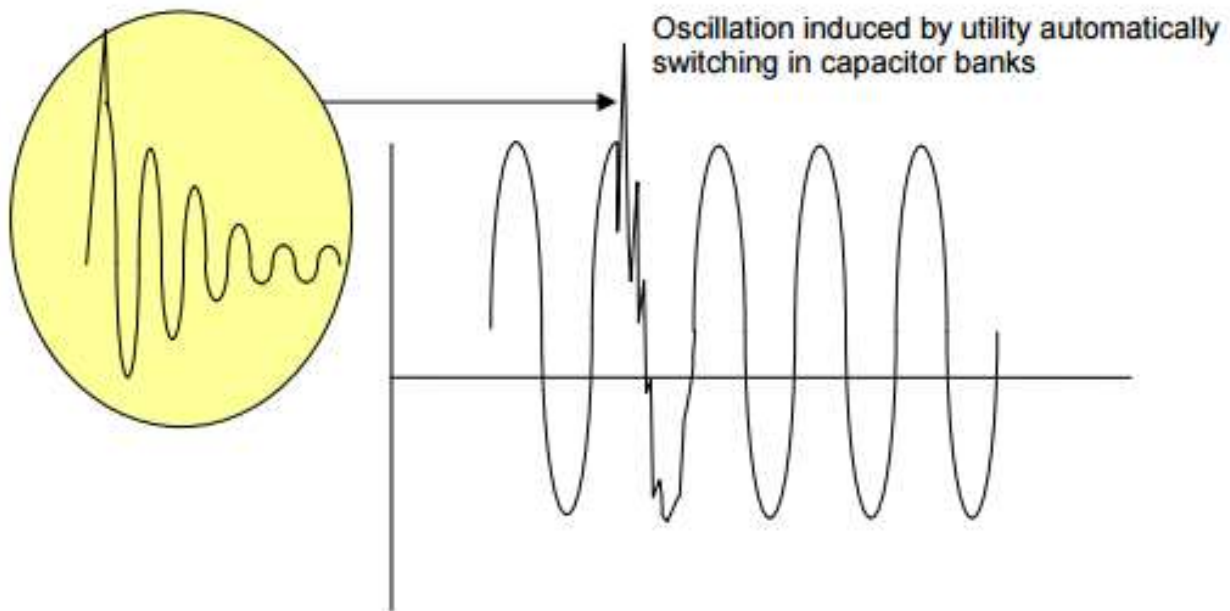

Figure 21. Oscillatory Transient⁶⁴

In a home, transients will be primarily generated through inductive switching, with capacitive switching being uncommon in a home and are typically only at the utility level or at large industrial facilities. The interactions however between the inductive and capacitive loads can cause oscillations as well, resulting in transients which can increase the voltage spike.⁵⁵ Current transients are typically caused by motors starting, and will cause little damage if the circuit breaker or fuse is not tripped. Voltage transients can be caused by switching or resonance conditions, or by factors related to the electrical distribution system. Voltage sags that are one cycle or less will have little effect on the home electrical system and smaller voltage dips will also not have much impact if they do not last long. In addition, most electrical equipment can withstand a range of input voltages, so a slight deviation from 120V will not be critical.⁵⁶

⁵⁴ Seymour, J. (2012, May 4). *The Seven Types of Power Problems*. Retrieved from Schneider Electric: http://www.apc.com/salestools/VAVR-5WKLPK/VAVR-5WKLPK_R1_EN.pdf?sdirect=true

⁵⁵ Davis, E., Kooiman, N., & Viswanathan, K. (2014). *Data Assessment for Electrical Surge Protection Devices*. Quincy: The Fire Protection Research Foundation. Retrieved from <http://www.nemasurge.org/wp-content/uploads/2015/01/Surge-Protective-Devices-for-Residential-Applications-Phase-1-Final.pdf>

⁵⁶ Generac. (2011, January 26). *Transients in mission critical facilities*. Retrieved from Generac Industrial Power: <http://www.generac.com/industrial/engineer-resources/news-whitepapers/industry-news/transients-in-mission-critical-facilities>

2.10 Summary

There are many different grid tie solutions and configurations out on the market, but they all have common elements and similar system layout configurations. Solar inverters are the backbone of any solar PV installation because they are responsible for detecting a grid outage and determining whether to shut down or if backup power is available, switch to backup power. Automatic transfer switches are needed to disconnect the home to either a battery backup or standby generator. There are many different ways to configure battery backup storage. Batteries can be placed between the solar PV and inverter or separately attached to a secondary breaker panel with a charge controller that serves as the backup circuits. Microinverters are similar to central inverters except that each microinverter attaches to each panel, and are daisy chained together. Microinverters also have MPPT built into them already, which eliminates the need for system level MPPT tracking. Transients are sudden voltage or current spikes (or oscillations) that can occur when switching on inductive or capacitive loads. They can cause damage to electrical equipment if not properly mitigated.

3.0 Problem Statement

3.1 Introduction

Currently, if a homeowner wants to install solar panels to reduce their electric bill, they will often go with a grid-tied solar system. In the event of a power outage, a homeowner is currently not allowed to run their inverter in order to prevent line back-feed, and therefore cannot use their solar energy, despite power being readily available. To address this issue, one approach is to install a hybrid grid-tie system. These systems offer a grid-tie with a battery backup, but only to preselected circuits in a separate breaker box, which cannot be changed unless an electrician rewires a breaker box. Hybrid grid-tie solutions still do not address the desire to dynamically allocate available power to the homeowner's circuits without the need for an electrician.

3.2 Problem Statement

The purpose of this project was to prototype a device known as a "Smart Home Energy Controller" that would allow residential solar panels to operate during a power outage. Specific design objectives for the prototype included the following.

1. Accept power from a variety of sources such as solar or batteries.
2. Dynamically allocate available power to different circuits based on alternative power available during a power outage using electronically controlled breakers and an optimization algorithm.
3. Be able to island the home after an outage has occurred and keep solar system online.

The specific goals of this project were to research, design, simulate, and build selected components for the smart home energy controller. To accomplish these goals, the following objectives were addressed:

1. Perform background research on all relevant devices and systems that will connect and directly interact with the smart home energy controller.
2. Explore system architectures best suited to achieve the project goals based on existing systems.
3. Design a small-scale version of the smart home controller, and a test bed to test the system.
4. Test selected components.
5. Write a detailed report.

3.2.1 Perform Background Research

The team researched the types of solar systems on the market as well as how hybrid grid tied solar systems work. In order to design the smart home energy controller, the team needed to understand how it would interface with existing systems. The background research was critical to understand the limitations of existing technology in order to create solutions for these limitations.

3.2.2 Explore System Architectures

Similar to background research, the team needed to understand how solar systems and their subcomponents are architected. This included knowing how solar inverters communicate with other devices, and what components (like automatic transfer switches, voltage sensors) are inside each device in a solar system. This understanding of how components are designed and architected gave the team ideas for how to architect the smart home energy controller.

3.2.3 Design the Smart Home Energy Controller

The team applied engineering practices and system engineering principles to design a functional smart home energy controller that could island itself from the main utility grid and dynamically control its loads. To accomplish this, the background research was utilized along with the various stakeholder and design needs, uses cases, and a defined operational environment. While creating the design, schematics were generated and implemented into the overall test bed. The required system logic was developed into a flow diagram and a system context diagram was created in order to understand all the inputs, outputs, and functionality required. After this, the team went through design reviews for each component until a prototype of the smart home energy controller was fully designed.

3.2.4 Test Selected Components

The team tested certain off the shelf components that would be integrated into the smart home energy controller, such as the electronic breakers, transfer switches, and sensors. The purpose of this testing was to confirm that these devices would function as designed inside the smart home energy controller.

4.0 System Concepts

4.1 Introduction

In order to design and architect the smart home energy controller, the team took a systems engineering approach to tackling the design aspect, the stakeholders, and all the relevant analysis and processes necessary to produce a high quality and well thought out design.

4.2 Stakeholder Analysis

4.2.1 Stakeholders

Stakeholders are the parties that will be impacted by or have an interest in the design and implementation of the smart home energy controller. Each stakeholder in Table 1 was given a stakeholder ID (SH ID) along with their potential role in the project or explanation of interest in the project and the device. A priority was assigned with 1 being the highest and 3 the lowest in terms of impact by the project. The stakeholders' needs were also assessed relative to their impact by the project.

Table 1. Stakeholders and their Interests

Interests	Homeowner SH. 01	Designer SH. 02	Utility SH. 03	UL SH. 04	Electrical Inspector SH. 05	FCC SH. 06	Installer SH. 07
Simple Installation	3				3		1
Easy to use	1	2					2
Reliable	1	2	1	2			
Maintenance free	1	3					
Compliance to Standards		2	1	1	1	1	

4.2.1.1 SH. 01

The first stakeholder is the homeowner, which is the target end user. The smart home energy controller will be installed in their home for their benefit, and during the event of a power outage, the controller will provide power to selected circuits in the home by intentionally islanding the home. The homeowner requires a device that is as automatic and simple to use as possible.

4.2.1.2 SH. 02

The designers or project team are responsible for designing the device and have a vested interest in seeing the project succeed. The designers will determine the scale of the project and the system architecture to ensure the device has all the necessary functions and meets the prioritized needs of the stakeholders.

4.2.1.3 SH. 03

The utility company or electric power provider to the home have an interest in the project for safety reasons to prevent the back feeding of power into the grid. It is important to prevent back feeding into the grid so if power lines are downed, line workers will not be injured or worse when they are working on utility lines. The utility also wants to prevent frequency issues on the distribution system and prevent power quality distortions. Another interest of the utility would be to see data on solar power production and ensure that the home is isolated according to their standards.

4.2.1.4 SH. 04

Underwriters Lab (UL) has an interest in compliance to standards and reliability. They would like to product to be safe and comply with standards such as the National Electric Code (NEC). Reliability would also be an interest for UL as a reliable device is less likely to experience malfunctions and cause damage.

4.2.1.5 SH. 05

The Authority Having Jurisdiction (AHJ) is a local municipal or state inspector would have a stake should the smart home energy controller concept become a product. Their role would be to inspect the installation and equipment to ensure proper compliance with local and state laws. This role involves checking compliance with the NEC portions and addendums that has been adopted into state law.

4.2.1.6 SH. 06

The FCC only has a stake in the project if there are wireless transmissions for data. The FCC needs to ensure that the device does not broadcast on frequencies not permitted at the appropriate power levels.

4.2.1.7 SH. 07

The system installer's role is to install the smart home energy controller and wire the solar system correctly. They desire the device to be as simple and easy to install as possible.

4.2.2 System Needs

The system needs are the functions that the smart home energy controller should do. They are derived from the stakeholders so that all needs are traceable to a certain stakeholder. These needs are functions that the device must have to fulfill the desires of the specific stakeholders. The system constraints, inputs, and enablers all contribute to each need. Table 2 details these needs.

Table 2. System Needs

ID	Title	Description	Traceability	Priority	Complexity
N. 01	Detect an outage	The system should detect an outage and power quality issues.	SH. 03 SH. 05	High	Low
N. 02	Dynamic Power Distribution	The system should automatically allocate available power to user selected circuits.	SH. 01 SH. 02	Moderate	High
N. 03	Isolation and Islanding Capabilities	The system should island the home according to regulations to prevent power back feed.	SH. 03 SH. 04 SH. 05	High	High
N. 04	User Programmability	The system should be easy and intuitive for a user to program.	SH. 01	Moderate	Moderate

4.3 CONOPS

CONOPS stands for the concept of operations which describes how it will operate and for whom the system will operate for.⁵⁷ The system functional requirements are what the system must do in order to operate and function. All of the functional requirements, like the needs should be traceable to a stakeholder.

4.3.1 Expected Operational Environment

The smart home energy controller is expected to operate inside a home, which means the device will likely be insulated from outside weather. It should also be in a location where proper airflow can ensure the device does not overheat (i.e. not in a closed space). The humidity operating conditions will depend on the tolerances of the circuits and components inside the smart home energy controller.

4.3.2 Use Cases

Tables 3 to 6 present the various use cases a user might have for the smart home energy controller, along with the various use case exceptions. A use case is written from the user's perspective and is a step by step guide that details how the system will respond or operate in specific situations. It details the starting assumptions, the steps needed to obtain the desired outcome, and potential variations that may occur while attempting to reach the desired outcome. The use case is important as it allows the designers to understand how the device will be used so it can be designed with the user's perspective in mind.

⁵⁷ Kossiakoff, A. (2011). *Systems Engineering Principles and Practice* (2 ed.). Hoboken: John Wiley & Sons, Inc.

Table 3. Use Case for Selecting Circuit Prioritization

Use Case	UC01: Selecting circuit priorities.
Description	The smart home energy controller requires the user to select which circuits they want to keep on in the event of a power outage, and in what order of priority.
Actors	Primary: Homeowner [SH. 01]
Successful Outcome	User is able to select which home circuits and in what circuit order they want the backup system to try to keep online.
Assumptions	<ul style="list-style-type: none"> • The homeowner has preselected which circuits go to which breaker. • The homeowner does not try to plug in more devices that draw significant power while backup power is online.
Steps	<ol style="list-style-type: none"> 1. User decides what circuits to prioritize 2. User inputs a numerical number corresponding with a breaker as first priority. <ol style="list-style-type: none"> a. Exception: User accidentally enters the wrong number b. Exception: User selects the wrong priority number 3. User then repeats step 2 until they have entered all the circuits they feel are most critical.
Variations	1: User can set priorities for as many or as few circuit as they want.
Non-Functional	<p>Reliability: The system will attempt to power all circuits with backup power but if it cannot, it will dynamically allocate power to select circuits based on the user's prioritization.</p> <p>Modifiability: Circuit prioritization can be reconfigured at any time without the need to rewire anything.</p>
Discoveries	<ul style="list-style-type: none"> • If the user forgets to even enter circuit prioritization, the system should either force the user to enter at least one circuit (by not functioning upon install), or select circuits based on previously known power draws before outage occurs • User needs a way to correct mistakenly entered circuit numbers/prioritization.

Table 4. Use Case for Measuring Power Flows

Use Case	UC02: Measuring Power Flows
Description	In order to calculate power flows to determine which prioritized circuits should be powered during an outage. The microcontroller must be able to sense and record the measured line currents for each circuit. The controller should also be able to display the system voltage whether it is being supplied by the UPS or the grid.
Actors	Primary: Homeowner [SH. 01]
Successful Outcome	User is able to quickly learn how much power they are consuming.
Assumptions	<ul style="list-style-type: none"> • The user has connected the smart home energy controller and fully connect it to the loads. • The user is able to access the measurements from the microcontroller. • The default language is English.
Steps	<ol style="list-style-type: none"> 1. User connects to the microcontroller with a computer to observe the output of the current and voltage sensors. 2. User loads the program to read the microcontroller output and measures the sensor outputs. <ol style="list-style-type: none"> a. Exception: The program does not load, so the user reloads the program until it functions.
Variations	<ol style="list-style-type: none"> 1. User can use a variety of different electronic devices to see the data through the internet.
Non-Functional	<p>Reliability: The system needs be able to accurately display real time information to the user.</p> <p>Modifiability: The user needs to be able to change various system settings with ease</p> <p>Frequency: The information needs to update close to real time.</p>
Discoveries	<ul style="list-style-type: none"> • A simple user interface with a graphical display would be desirable.

Table 5. Use Case for Pressing the Emergency Stop Button

Use Case	UC03: A Catastrophic event has occurred and an immediate complete system shutdown is required.
Description	The UPS/grid input will need a shutdown button in order to quickly shutdown the system in the event of a catastrophic failure.
Actors	Primary: Homeowner [SH. 01]
Successful Outcome	The UPS inverter shuts down, which causes the solar PV inverter to shut down as well
Assumptions	<ul style="list-style-type: none"> • The main controller hasn't been destroyed in a fire. • The UPS isn't the cause of the failure
Steps	1. User presses power button on the UPS
Variations	None
Non-Functional	Reliability: Device needs to shut everything down, no exceptions. And it must do it as fast as possible.
Discoveries	<ul style="list-style-type: none"> • The UPS off button must be readily accessible

4.3.3 Gap Analysis

The gap analysis compares the current capabilities of technology to the desired future state of technology to identify what developments are needed to meet the needs of the project. By identifying the capabilities that current devices and technology are lacking, the team will be better able meet the needs of the smart home energy controller. To determine where the gaps exist, the current state of the art was compared to the desired state of art which results in the gap. Next, the risk of closing the gap was assessed and a development plan created. While many gaps can be identified, not all gaps will have to be closed by the project team.

Table 6. Gap Analysis

Current State	Desired Future State	Gap	Development al Risk(s)	Development Plan	Comments
Automatic Transfer Switches (ATS) - Primarily used for instantaneous transfer to backup power.	An islanding switch that is capable of fully isolating the house from the grid and sensing grid outages.	Creating an intelligent switch capable of islanding while following regulations.	Low - ATS's are readily available so implementing one should pose low risk.	Use an ATS to form the basis of the isolator and improve sensing and isolation.	Low risk, can adapt existing technology for the challenge.
Circuits can only be preselected for power by an ATS, not reconfigurable.	Reconfigurable switching of selected home circuits by the homeowner.	After installation control of home's power distribution.	Limited - automated circuit breakers for switching already exist.	Create a controller to handle switching and selection of the owners preferred circuits.	Technology exists in principle, must be modified for this application.

4.3.6 Design Needs

Based on the stakeholder needs, the device should have certain design features in order to become a functional product. Design needs can be implemented in a variety of ways, but their purpose is to enhance the feasibility and usability of the device. An example of a design need is size of the device. If the device is too large, it becomes cumbersome to the user and installer, but if it is too small, it can be difficult to use as well. The device will function either way, but the design need specifies the assumptions or standards that a user would likely have.

Table 7. Design Needs

Design Needs	Traceability to Stakeholder	Priority
The system should have breakers with manual overrides. Electronic controls must not have a way of overriding this.	[SH. 01], [SH. 04]	High
The system should accept power from solar PV, batteries, and grid.	[SH. 02]	High
The system should have an isolator switch that must automatically island home when the power goes offline.	[SH. 02], [SH. 03]	High
The system should have a control unit to provide monitoring and system controls.	[SH. 02]	High

4.3.4 System Specifications

In order to work in the North American grid system, there are certain technical specifications the smart home energy controller must run at in order to be compatible. Table 10 provides the electrical specifications of the device. The system needs to be capable of operating at both 120V and 240V because all the loads in a home are on a single phase but the breaker box is split phase. This means all the loads should receive 120V but the voltage potential between the two phases needs to be 240V per utility regulations. The individual circuit breakers should range from 15-30A, though an electrician will appropriately size the breakers depending on the circuit loads. Lastly, the system should have standard NEMA 5-15 outlets, which is the electrical outlet most commonly found in homes and businesses.

Table 8. Electrical Specifications

Category	Specifications
Electrical	120/240V AC (+/- 5%) 60Hz (+/-0.01Hz) Circuit breakers need minimum 15-20A ratings Standard Plug connector types

4.4 Final System Architecture

4.4.1 System Architecture

After analyzing all the stakeholder needs, the team went through a design process of determining all the inputs and outputs needed for the entire smart home controller system. Through this process, the system functional block diagram in Figure 27 was created. In addition to Figure 27, see Appendices A, B, and C for some color-coded breakdowns of what is flowing through each arrow in the diagram.

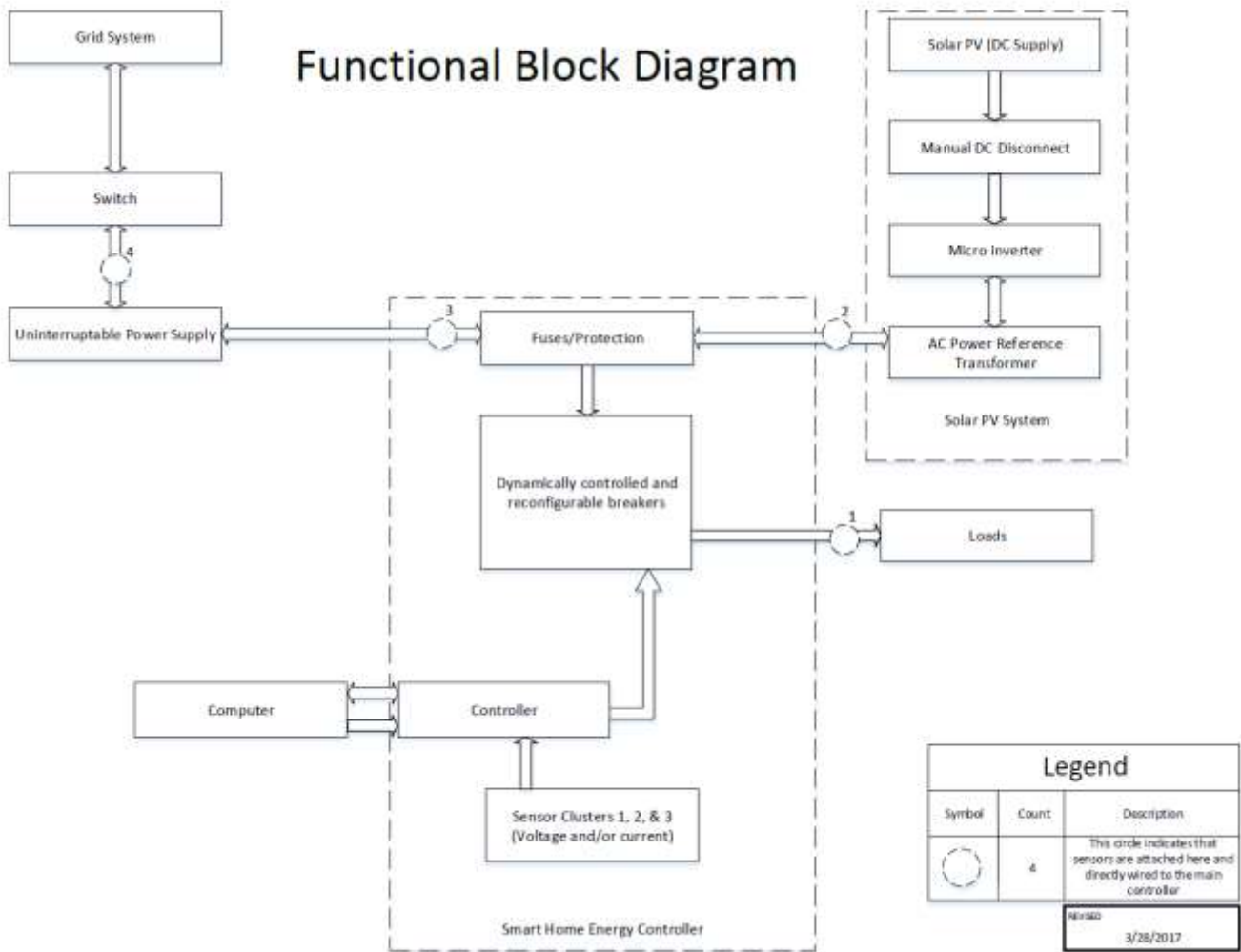

Figure 22. System Level Functional Block Diagram

Starting at the top left of Figure 22, power flows bidirectional from the grid system to the main busbars inside the smart home energy controller. The power flows bidirectionally due to the need to use grid power when solar power is not sufficient and to export excess power to the grid when there is a solar surplus. Downstream from grid system connection is a switch that the team will use to terminate the grid connection to force the system to enter off-grid mode. After the switch is a pure sinewave battery based uninterruptible power supply (UPS). The UPS has an automatic transfer switch built in that will transfer the loads from grid power to backup power. This is necessary in order to “trick” the microinverter to stay online and continue supplying power in off-grid mode, something they were not originally designed to do. The current solar trend is moving toward microinverters so it becomes necessary to show off-grid microinverter functionality. The system will need a way to sense if the grid has gone offline, and one way to do this is place a current sensor before and after the UPS (shown by circles 3 and 4 in Figure 22).

4.4.1.2 Smart Home Energy Controller

Inside the smart home energy controller, all the power inputs and outputs meet at the busbars. On each power connection is an AC current sensor indicated by a dashed circle in Figure 22. The current sensors then send a signal directly into the microcontroller. The purpose of these sensors is to monitor the amount of power being consumed by each load and coming from the UPS.

As power flows from the UPS to the dynamically controlled and reconfigurable breakers, they will pass through some fuses, which are designed to protect the system in the event of a short circuit. Since both the microinverter output and grid input are fused, regardless of where a short might occur, the system will safely blow a fuse and disconnect. There are electronically controlled breakers immediately downstream from the fuses whose purpose is to provide a way to reconfigure at will with software what circuits are actively being powered during a power outage. The software controlled breakers allow for automatic load optimization during an outage to accommodate demand surges or power fluctuations as the smart home energy controller can automatically drop or restore loads based on pre-set user priority.

The microcontroller will be connected to a computer in order to read sensor data in real time as well as receive DC power and commands from the computer to demonstrate features of the smart home energy controller. By configuring the software of the microcontroller, the user can change the prioritization of each load in real time. The microcontroller will also be able to interpret available power from the solar system right before a grid outage occurs, and accordingly optimize the power distribution to maximize power usage in off-grid mode while keeping power from the UPS at a minimum. Two key features the smart home energy controller will demonstrate are load prioritization (trying to keep loads on in order of desired priority when possible), and power optimization (maximize available power). So for example, if the system does not have enough power for priority loads 1 and 2 but enough for 1 and 3, it'll turn on loads 1 and 3.

4.4.1.3 Solar PV System

Starting with the solar PV, the DC connection goes through a manual DC disconnect that will shut off solar power if work needs to occur on the panels or the microinverter. The microinverter is supplied with an AC power reference transformer whose purpose is to supply a 240V AC signal to the microinverter. The transformer is needed in order to get a split phase microinverter that is meant for a home's breaker box to work with a single-phase test setup.

4.4.2 System Control Logic

The system control logic for the smart home energy controller is shown in Figure 23. The starting condition for the control logic is to determine if grid power is online, and if it is, then look at solar PV generation versus house demand. If the house demand is greater than the solar generation, it will supplement the power by using power from the grid. Otherwise, it will send excess power to the grid. If there is no grid power, then the device immediately islands the home. Once the home is islanded, the controller then checks to see if solar PV generation is sufficient to power the house based on the power usage that was recorded before the power went out. If the solar generation is greater than the recorded usage, then smart home energy controller will run the house off of solar PV. If the solar PV generation is lower than the recorded usage prior to the outage, the controller determines if solar power and battery power is enough to power the home. After that the system will attempt to dynamically allocate power based on load prioritization in order to conserve battery usage. When the smart home energy controller find an optimal amount of power to use based on load prioritization, then any excess power will be used to charge the batteries. Should a worst-case scenario happen where the battery runs out and it is night, the home simply blacks out then and waits until daylight or grid restoration.

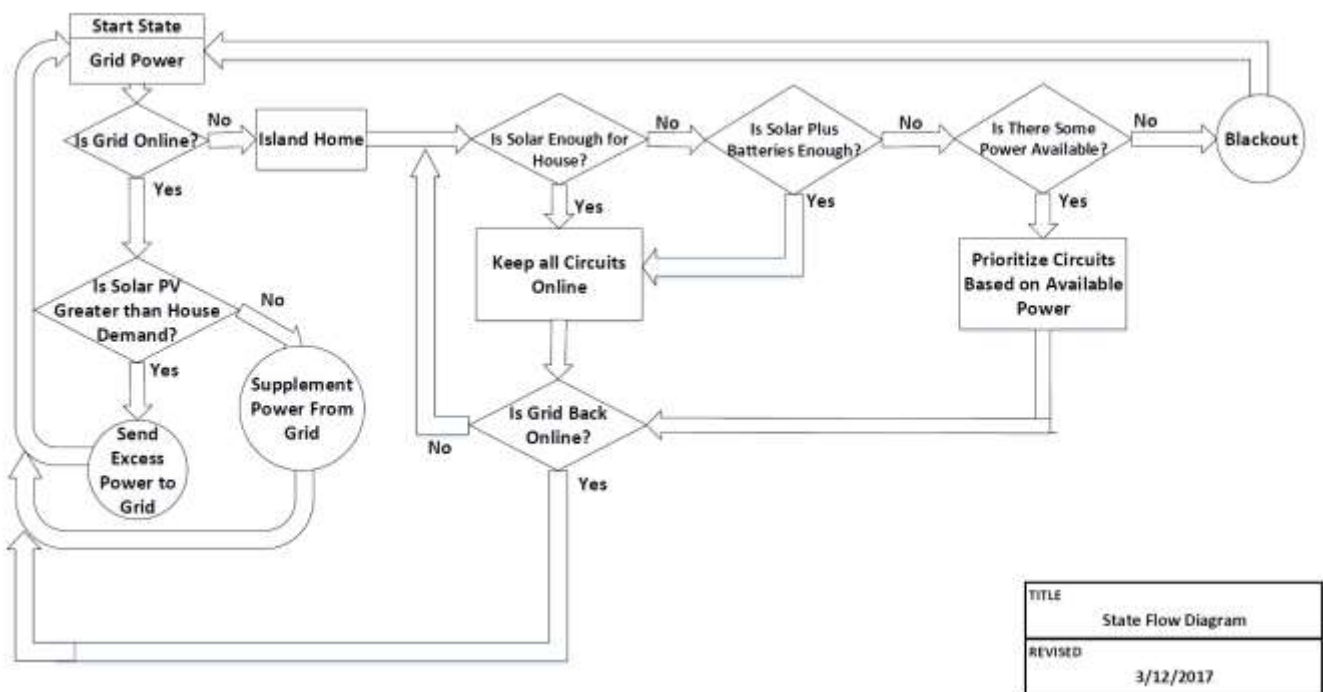

Figure 23. State Flow Logic for Controller Algorithm

4.5 Summary

The primary considerations driving this project and the system architecture are the various needs of the many stakeholders involved in the project. These stakeholders range from the smart home energy controller users to the utility company, and each one has system needs and requirements that must be fulfilled. The team analyzed each of the stakeholder needs and conducted a gap analysis to identify limitations in current technology. Along with the system requirements, specifications, and design needs, a high-level system architecture was devised. The system functional architecture is outlined in Figure 22 and color coded breakdowns of Figure 22 can be found in Appendices A, B, and C. The functional block diagram is needed to explain how all the inputs and outputs are connected to the smart home energy controller and how they interconnect with other blocks/functions. The controller logic is outlined in a state diagram in Figure 23, which explains how the controller makes decisions based on various inputs and operating conditions.

5.0 Prototype Test System Design

5.1 Introduction

The smart home energy controller prototype was designed to demonstrate the switching of loads and sources during an outage along with prioritization of loads once the grid is lost. This test bed was constructed based off the designs in the functional block diagram in Figure 22 to demonstrate the capabilities of the smart home energy controller. The main features the test setup demonstrated were islanding capabilities, automatic load prioritization, and the use of off-grid microinverters. While the proposed smart home energy controller would also work with a central inverter, microinverters were chosen to in order to better demonstrate changing power availabilities (i.e. when the sun sets). The team sought to understand how switching motors on and off can affect the overall system stability in an off-grid application.

5.2 The Setup

Figure 24 illustrates how the test setup receives power from a wall outlet and is used to power the UPS, which in turn powers the test setup. The thicker lines in Figure 24 are busbars, which serve as common points in the system, similar to how a breaker box is constructed. The circles with numbers represent a wiring continuing onto another page (Figures 26, 28, 29). The test bed is powered from a 120V AC, 15A wall outlet through a light switch that acts as the switch to set the system to on-grid or off-grid mode.

From the light switch, the electricity goes into a current sensor, and then into the UPS. From the UPS, the electricity flows through a 2A fast blow fuse, then into the system busbars. The UPS acts as the transfer switch when power is lost, switching the load from the grid to a DC power supply and microinverter representing the solar system, as well as supplying a small amount of current from its own internal battery. Between the fuse and the hot busbar, there is a current sensor to measure current flowing out of the UPS. The solar system supply is a 31V, 3A DC source, as those are the max power outputs the supplies used could handle. To convert the DC sources to AC, a microinverter is used. The microinverters represent a solar PV system and follow the UPS output to stay online during off-grid or on-grid scenarios. Branching off the hot busbar is the remote-controlled circuit breakers (Eaton BABRP1020 circuit breakers) that protect both the loads and microinverter. There are three busbars in the test setup, one serving as the hot bar, one as the return bar, and one as the ground bar. The four loads consist of individual light bulbs. A ¼ HP motor was also attached, which was used to demonstrate special cases, such as transients and how sudden large loads affect the overall stability of the system. The motor however was not used as a typical load. The team also observed the busbar waveform on an oscilloscope to record any potential transients due to the motor switching on and off.

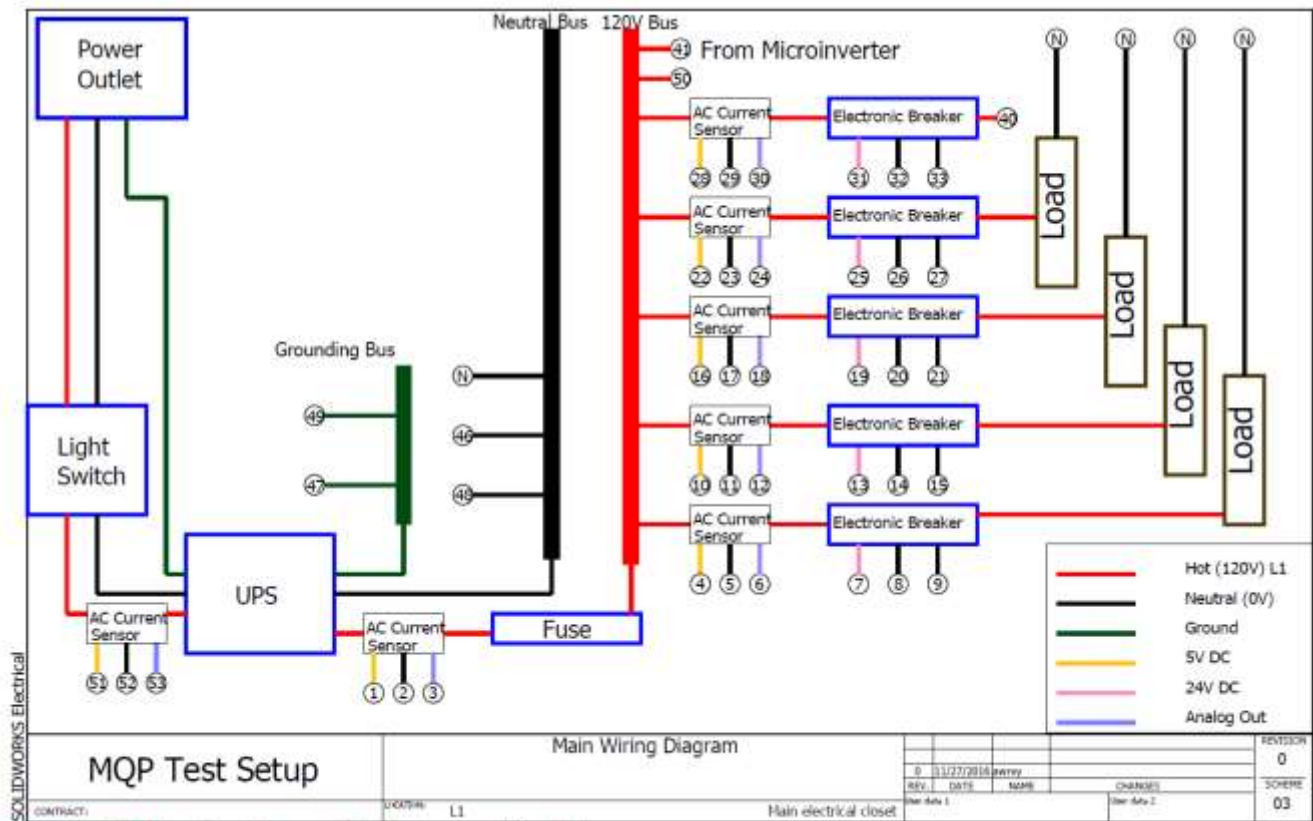

SOLIDWORKS® Educational Product. For Instructional Use Only.

Figure 24. Main Test Bed Wiring Diagram

5.2.1 Electronically Controlled Breakers

The 20A remote controlled breakers are operated by pulsing a ground level signal to the red or black wire with 24V DC permanently applied to the blue wire. This signal operates the solenoid in the breaker to open or close, with the manual breaker lever having the ability to override the remote-controlled breaker. The wiring diagram from the manufacturer for the BABRP1020 remote controlled breaker can be found in Appendix G.

5.2.2 Pure Sine Wave UPS

The UPS used (CyberPower CP850PFCLCD) is a pure sine wave UPS, which is necessary for the microinverters to follow as a reference signal. It has a transfer time of 10ms between grid to battery mode. In addition, the UPS has a circuit breaker built in to help protect against overcurrent conditions, adding additional safety to the test setup.

5.2.3 Voltage Sensor

In order to accurately read the busbar voltage of our test setup, a custom AC voltage sensor was used to convert AC RMS voltage to a DC voltage that a microcontroller could read and interpret. The power from a wall outlet is 120V RMS, but the actual voltage peak value in an outlet is 170V. The circuit must be able to convert the peak voltage value into DC, from which the microcontroller can then mathematically compute the RMS value by dividing by $\sqrt{2}$. The circuit in Figure 25 uses a 20:1

transformer that steps the voltage down from 170V to 8.5V. The full rectifying diode bridge experiences about a 2V drop across it, bringing the output voltage to 6.5V. A 14:20 voltage divider then biases the voltage to 2.5V. The voltage would be biased to 2.5V because the microcontroller can only accept an input voltage of 0-5V. This gives the team a wide range of acceptable AC inputs ranging from approximately 200V RMS to 20V RMS. A potentiometer was used for the voltage divider circuit in order to give the team on-the-fly voltage adjustments. The time for this circuit to energize is approximately 2ms, which can be found in Appendix E. The custom circuit was chosen over an IC chip because it allowed the team to customize the bias point to match the microcontroller input, and has greater resolution and voltage ranges vs existing IC chips.

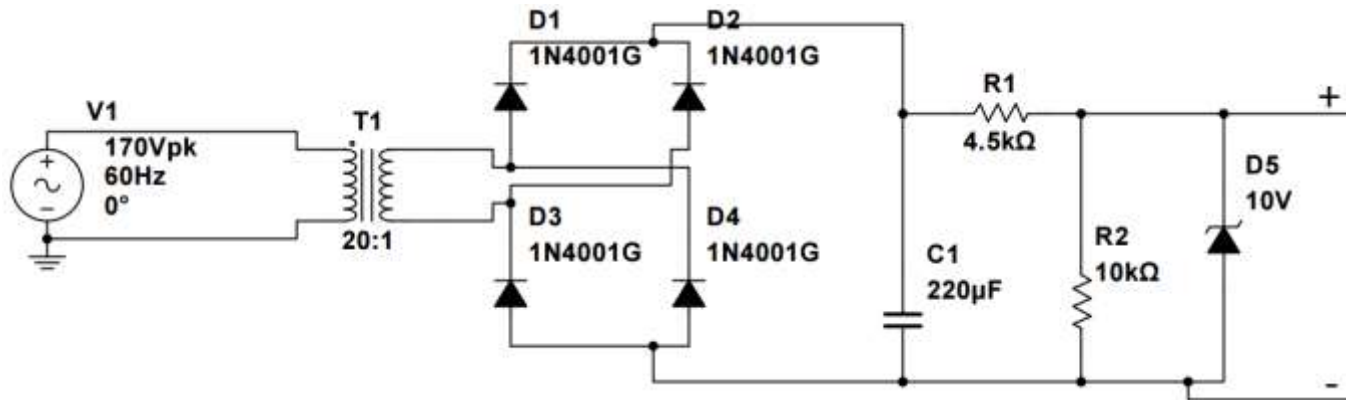

Figure 25. Custom AC Voltage Sensor Schematic

5.2.4 The Current Sensor

The current sensor chosen for the test setup is the ACS714 Hall Effect IC current sensor by Allegro Microsystems. This sensor is capable of reading +/- 30A of AC or DC current and operates at 5V DC.⁵⁸ These sensors input data directly into the microcontroller in real time. Each current sensor requires about 10mA of supply current to function so seven current sensors combined consumes about 70mA, which is well under the maximum 200mA the microcontroller chosen can provide.

5.2.5 The Microinverter

A microinverter was chosen for the test bed because its power requirements could be reasonably supplied in the lab with the available supplies, in addition to being more affordable than a central inverter. The microinverter chosen was the Enphase M190 microinverter as previously shown in Figure 8. This microinverter is capable of supplying 190W of AC power at 240V split phase. It has a minimum DC start voltage of 28V. It has an efficiency of approximately 95%.⁵⁹ The inverter has about a 1 minute wake up time and when it loses a grid signal, it will continue running for 250ms before it powers down, after which the inverter will wait 5 minutes to come online once a grid signal is restored. In the team's test bed setup, the UPS mimics the grid signal and keep the microinverter online continuously during off-grid mode.

⁵⁸Allegro MicroSystems. (2012, November 16). *Automotive Grade, Fully Integrated, Hall Effect-Based Linear Current Sensor IC*. Retrieved from Pololu: https://www.pololu.com/file/download/ACS714.pdf?file_id=0J196

⁵⁹ Enphase Energy. (2014, April 30). *Enphase Microinverter M190*. Retrieved from Magitek Energy Solutions: http://magitekenergy.com/docs/Enphase_M190_Datasheet.pdf

5.2.6 Microinverter Wiring

In order to use a microinverter with the test setup, the team designed the microinverter setup in Figure 26. Figure 26 shows a DC laboratory supply supplying the needed DC voltage and current for the microinverter to turn on. The DC supply can output up to 93W to the microinverter. The microinverter is then connected to a 1:1 center tap transformer via a connection where line 1 (L1) and neutral bypass the transformer. L1 and the neutral tie directly into the system's hot and neutral busbars respectively. The purpose of this is so that the power on L1 does not go through the transformer, enabling the team to use a much smaller and more affordable transformer by allowing the microinverter L1 to carry half of the output power. Only line 2 (L2) of the microinverter is connected to the transformer secondary, with both windings of the primary side connected to the system hot and neutral busbar. The placement of L2, however, was critical. It needed to be placed on the right winding such that it would be 180 degrees apart from the grid voltage signal. By doing this the full system power is not routed through the microinverter, rather it is primarily used to supply the second phase of the split phase system. This is what creates the 240V difference between the two lines, which is needed to turn on the microinverter. See Section 2.2.3 on split phase wiring for a wiring diagram.

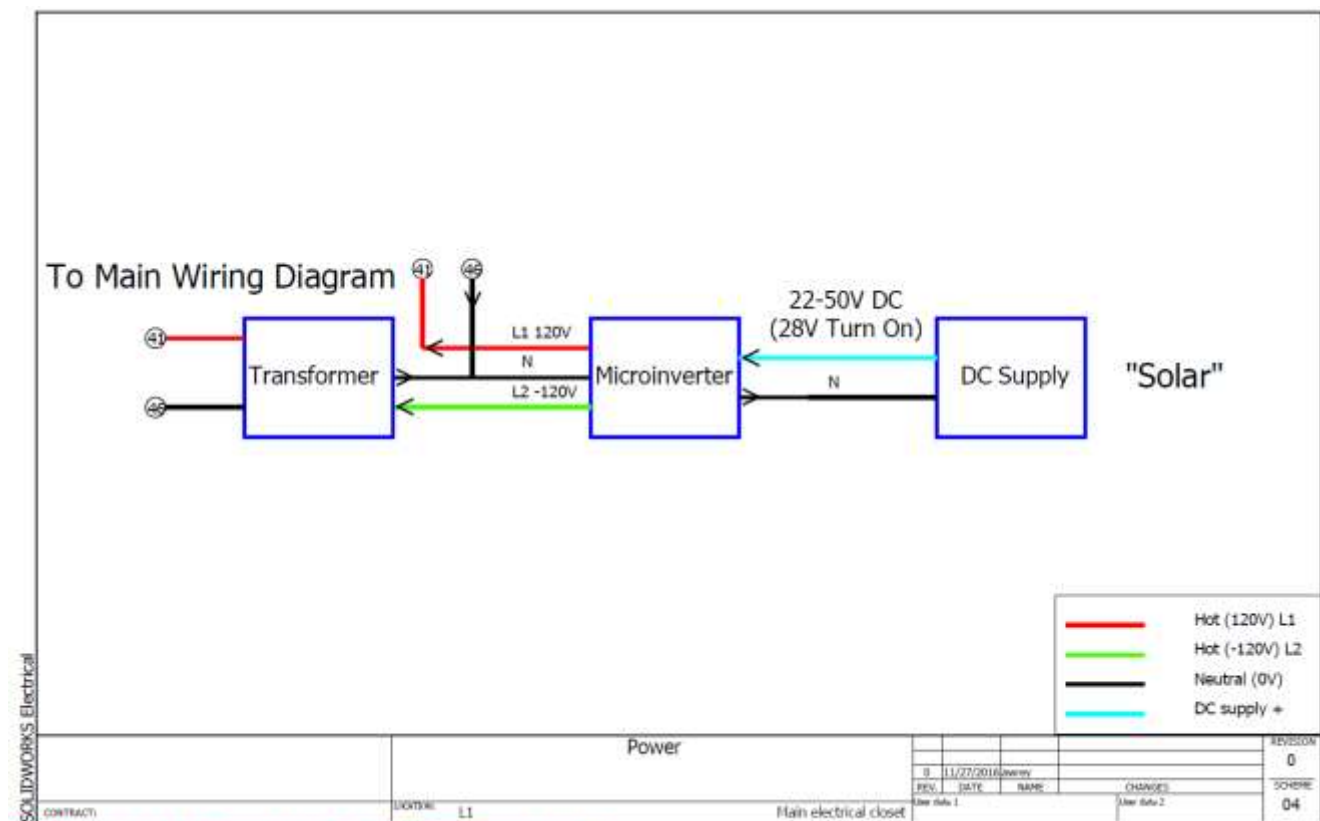

SOLIDWORKS Educational Product. For Instructional Use Only.

Figure 26. Solar System Power Wiring Diagram

5.2.7 Arduino Mega Board

In order to realize the core functionality of the smart home energy controller (the dynamical allocation and load prioritization), the team developed a simplified algorithm based on the logic flow in Figure 23. The core features this algorithm needed to demonstrate were:

1. Interface with current sensors to determine needed power levels
2. Prioritization of loads
3. Dynamically allocate power based on pre-selected load priorities
4. Power prioritization and battery conservation. I.E. prefer almost all power to come from solar and very little from battery, so battery could be used at a later time (such as at night)

The Arduino Mega board shown in Figure 27 was used because it offered enough analog input pins for the current and voltage sensors while offering sufficient processing speed and memory to handle the expected code. The Arduino also had enough digital 5V outputs to turn on and off 8 power MOSFETs that are required to actuate the 4 electronically controlled breakers controlling the 4 loads. C was the language used to program the Arduino, which enabled the team to implement the designed algorithms and functionality. Finally, the Arduino is powered via USB from a computer so that the Arduino can continuously pipe important data (such as voltage readings and current readings) to a laptop to be manually observed. The manual observation helps ensure the system is running correctly.



Figure 27. Arduino Mega Board⁶⁰

5.2.8 Microcontroller Wiring

The microcontroller wiring diagrams in Figures 28 and 29 illustrate how the Arduino controller is configured to receive and send signals. Figures 28 and 29 interconnect with Figure 24 as annotated by the numbered circles. On the right side of the microcontroller in Figures 28 and 29, the Arduino digital 5V outputs are connected to 100Ω resistors in series, then in parallel to a 1MΩ resistor tied to ground. The 100Ω resistor limits the current flowing into the N-channel MOSFET to not exceed the 20mA rating for each I/O pin. The 1MΩ resistor references the pin output to ground in order to keep the gate voltage from floating above the ground reference. If the 1MΩ resistor were not there, it is possible the output could float above the MOSFET source voltage such that it would get stuck and not turn on. The N-channel MOSFETs act as switches in the system to actuate the electronically controlled breakers on or off. To the left of the microcontroller in Figure 26, the purple lines represent analog inputs from either

⁶⁰ Reichelt elektronik, https://cdn-reichelt.de/bilder/web/xxl_ws/B300/ARDUINO_MEGA_A03.png

current sensors or the voltage sensor. These go into the analog input pins at the bottom of Figure 29. Finally, the black and yellow lines with many circle connections in Figure 28 show how all the current sensors are powered by supplying 5V via the yellow wire and a neutral return via the black wire.

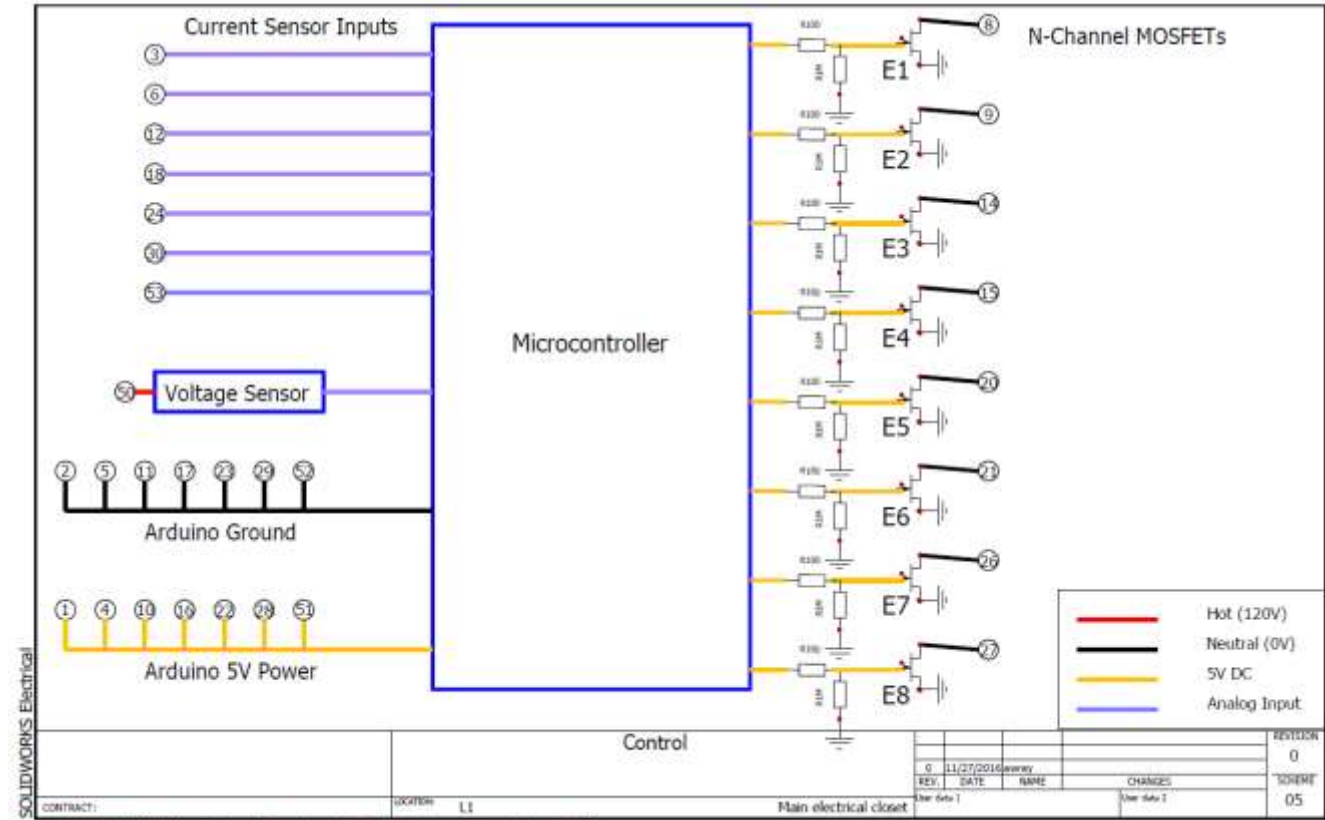

SOLIDWORKS Educational Product. For Instructional Use Only.

Figure 28. Microcontroller Diagram for Sensors and Electronic Breaker Controls

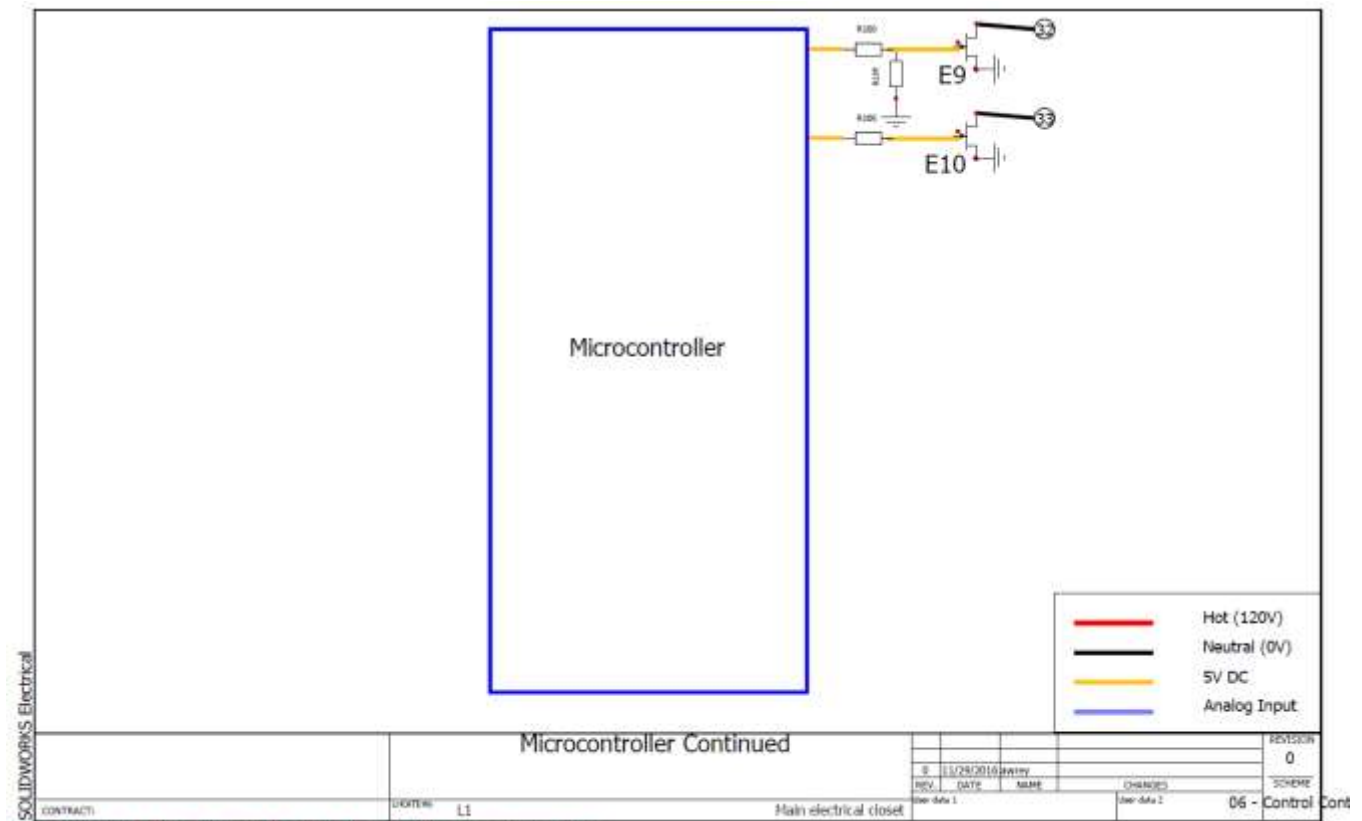

SOLIDWORKS Educational Product. For Instructional Use Only.

Figure 29. Microcontroller Diagram Additional Electronic Breaker Controls

5.2.9 Custom MOSFET Protoboard

In order to actuate the electronic circuit breakers, +24V DC needs to be applied to the breaker with only the desired ground connected in order to open or close. To accomplish this, the team designed a custom protoboard that contained eight power MOSFETS (Fairchild FQD5N50CTM_WS), eight 100Ω resistors, and eight 1MΩ resistors previously shown in Figures 26 and 27. The transistors are used to connect the appropriate grounds needed to turn the breakers on or off (see Appendix G). The custom protoboard has a 24V input and a 24V ground that is referenced to the Arduino ground in order to keep the gate voltage properly referenced relative to the MOSFET drain voltage. If the 24V ground was not referenced to the Arduino ground then the gate voltage would float at varying levels above (or below) the drain voltage.

5.3 System Testing Procedure

The test setup was mounted on a plywood board with the loads, microinverter, breakers, transformer, switches, current sensors, and Arduino on the bottom board in Figure 30. On the top board was the UPS, motor, current sensor and switch to control the input power from the grid. After each individual component was tested, the team built the test setup as illustrated in Figure 30 with annotations.

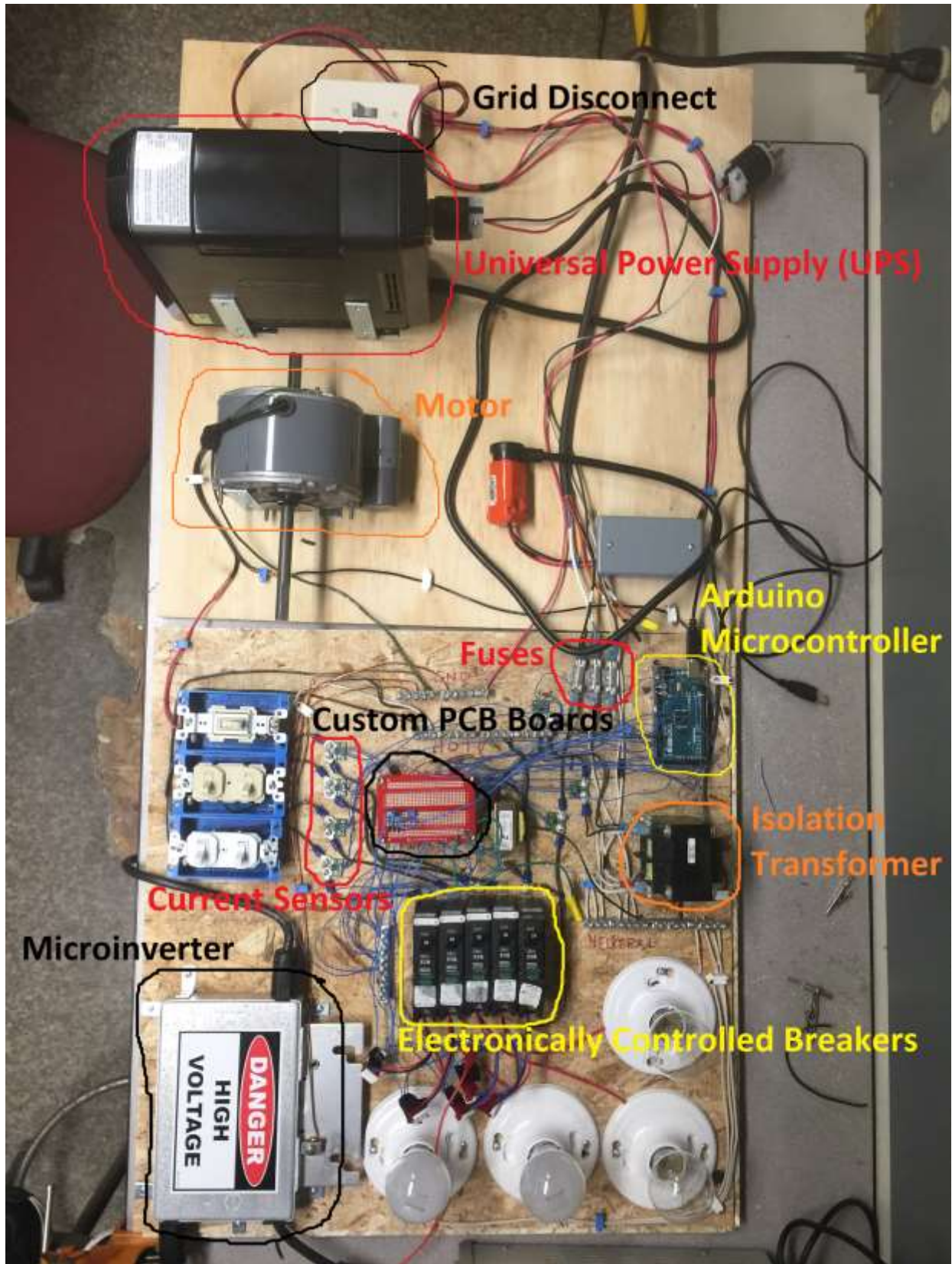

Figure 30. Mounted Test Setup

In Figure 30, the electricity flows from the outlet through the grid disconnect and a current sensor to the UPS. From there it goes through fuse protection into the busbars. The loads go through the electronically controlled breakers, light switches, current sensors, and then into the busbars. The center tap transformer connects the microinverter line two to the system's main busbars. As mentioned in Section 5.2.6, the center tap transformer is needed to interface the split phase microinverter to a single-phase system.

The three main scenarios the team wanted to test in order to fully demonstrate the smart home energy controller's capabilities are as follows:

- Test 1:** Demonstrate load prioritization by having the smart home energy controller receive only enough power to turn on priority loads 1 and 2, but not 3 or 4.
- Test 2:** Demonstrate what happens when the smart home energy controller does not have enough power to turn on priority loads 1 and 2, but has enough for 1 and 3.
- Test 3:** Demonstrate priority by only turning on load 1 when power levels are minimal, and to show the system can be designed to draw almost exclusively all its power from solar in order to demonstrate the ability to conserve battery power.
- Test 4:** Demonstrate dynamic power allocation by changing the DC power to the microcontroller in real time before entering off-grid mode to show how it responds to changes in solar power availability

In order to realize these four tests, the team preset the available power on the laboratory DC power supply that powers the solar microinverter. To start each test, the team first plugged the system into a wall outlet. The light switch connecting the UPS to the wall plug was turned on, then the UPS was turned on. At this point, the team connected the Arduino to the laptop and the 24V DC power supply was turned on which powers the electronically controlled breakers when they are activated. After the 24V supply was turned on, the DC solar supply was turned on.

Since the Arduino starts with the grid already on, it stays in "on-grid" mode. In this mode, the microcontroller simply takes readings of the system voltage as well as all the current sensors. It then stores this data and uses it to determine which loads it will be able to turn on based on available power it measures coming from the microinverter. The team set a maximum of 15W allowed from the UPS battery in the software with the goal to be as close to 0W as possible to demonstrate conservation of the UPS battery.

5.4 Component Verification

5.4.1 UPS Testing

5.4.1.1 Purpose

The purpose of the UPS was to provide power through a battery based inverter to the microinverter using AC coupling to keep the microinverter online when the grid is lost. The microinverter frequency and waveform will be determined by the UPS inverter, so the UPS must produce a clean sine wave for the microinverter. Two inverters were tested, an APC Back-Up RS 1200 modified sine wave inverter and a CyberPower CP850PFCLCD.

The CyberPower UPS has a max transfer time of 4ms or 1/4th of a cycle according to its documentation. The purpose of this test was to compare the waveform differences between the APC UPS and the CyberPower UPS as well as validate the transfer time for the CyberPower UPS. The transfer time for the APC was neglected because after confirming the microinverter would not follow a modified sinewave, the team elected to use the CyberPower UPS.

5.4.1.2 Procedure

To test the capabilities of the UPS, a load consisting of a light bulb was connected to the battery backup ports of the UPS and the grid power to the UPS was shut off. This allowed the team to observe the output waveform of the UPS in off-grid mode using an oscilloscope. The team also measured the time it took the UPS to start up the battery inverter from the moment the grid was lost. With the light bulb load attached to the UPS, the team also observed the switching from backup battery mode to main grid on the oscilloscope.

5.4.1.3 APC Back-Up RS 1200

The APC Back-Up RS 1200 inverter was tested first to view the waveform of the main line power during regular operation and the inverter waveform during battery based operation. The waveform for on-grid mode is shown in Figure 31. Figure 31 illustrates how utility power in the building where the test was conducted is a clean sine wave at 125V RMS and 59.95Hz.

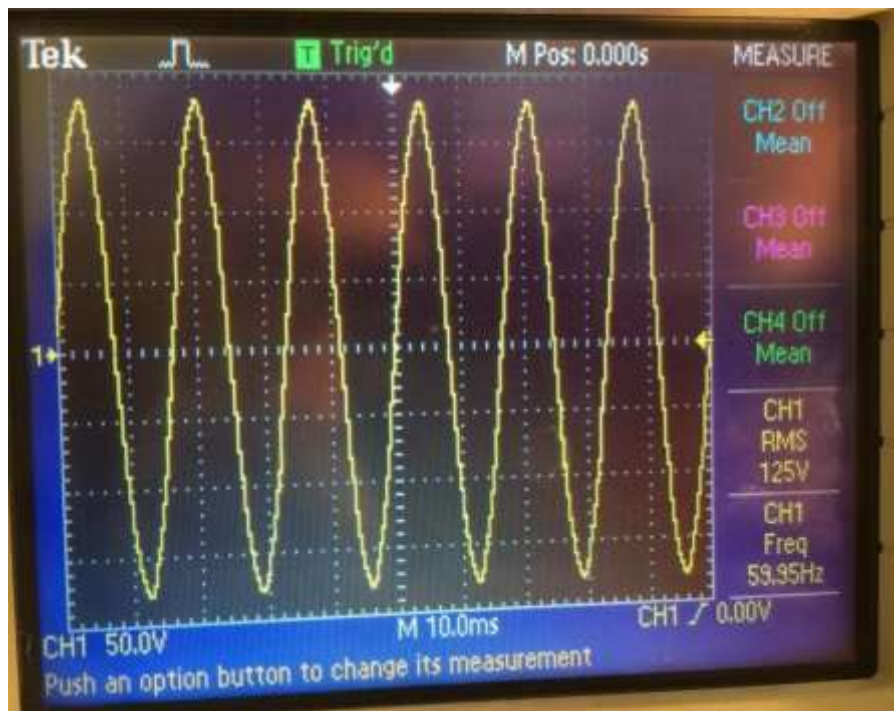

Figure 31. APC Back-Up UPS RS 1200 Main Waveform

The waveform of the UPS battery output is shown below in Figure 32, where there is only a single step in the waveform. It outputs 115V RMS at 60.1Hz.

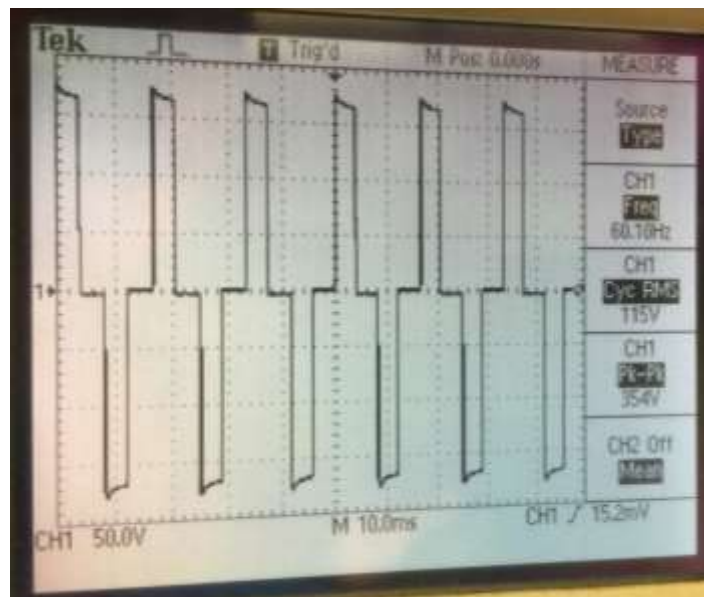

Figure 32. APC Back-Up UPS RS 1200 Inverter Waveform

5.4.1.4 CyberPower UPS

The CyberPower UPS was tested to observe the UPS switching from grid power to its battery backup and vice versa. A 72W light bulb was used as the load for the UPS and was connected to the UPS battery backup port. The UPS datasheets show a 4ms switching time, though the switching time in Figure 33 was measured at 10ms. The voltage recovers to 120V and 60Hz after the 10ms switching time. Appendix D shows a more zoomed in version of the transfer from grid to battery power.

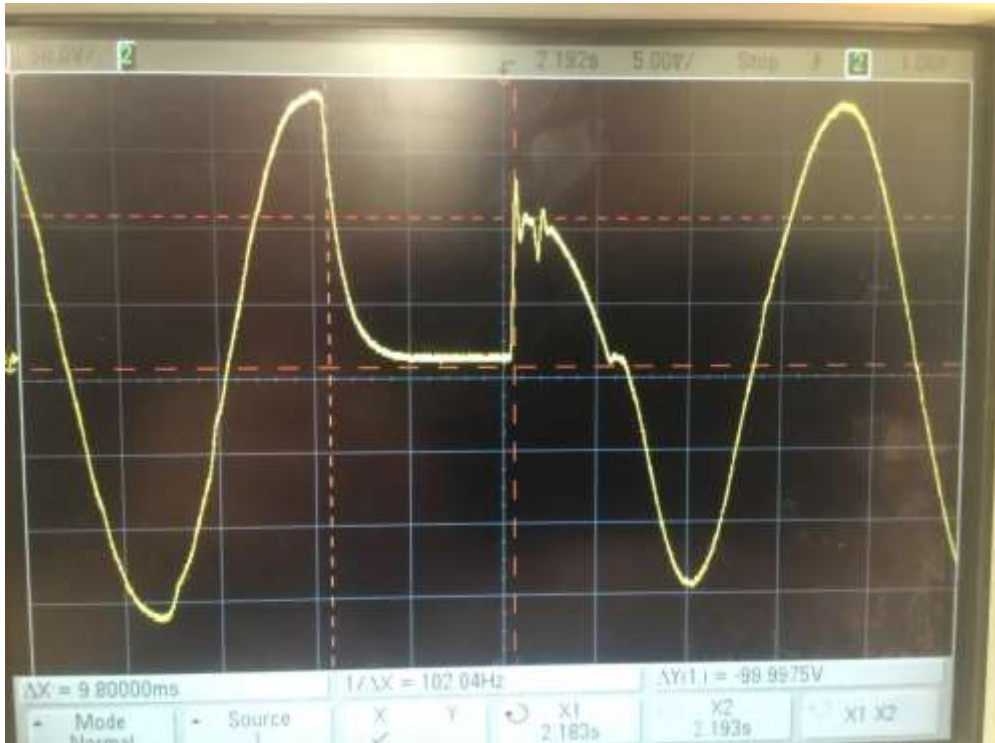

Figure 33. CyberPower UPS Grid to Battery Power Waveform

The recovery time from switching from the UPS battery to grid power was observed in Figure 34 to be less than a millisecond, and the UPS synchronizes with the grid frequency before switching over.

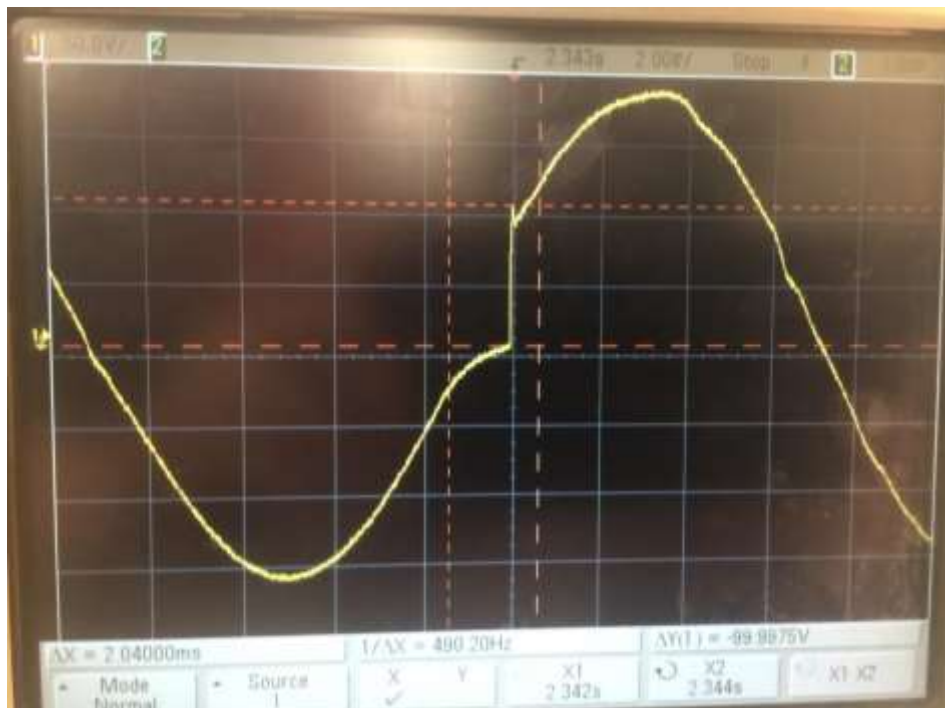

Figure 34. CyberPower UPS Battery to Grid Power Waveform

To test the CyberPower UPS, the oscilloscope and UPS with the light bulb load were separated with separate grounds. On the hot line of the UPS to the light bulb, a 2A fuse was placed to protect the UPS from damage. Initial testing showed that connecting the oscilloscope probe to the hot and neutral connections of the lightbulb would destroy the fuse, indicating a greater than 2A current draw. This is because there is no resistor on the oscilloscope ground and it connects directly to the wall outlet earth ground from the probe. To correct this, the oscilloscope was connected to the isolation transformer (Tripp Lite 1800W 120V) and the UPS to a normal wall outlet. This provides a separate hot and neutral connection between the oscilloscope and UPS, removing the path from the UPS hot to ground through the oscilloscope ground preventing the oscilloscope from shunting the full UPS output to ground.

5.4.2 Microinverter Testing

5.4.2.1 Purpose

The purpose of this test was to verify the functionality of the microinverter chosen and to demonstrate it would follow a UPS output in off-grid mode. Microinverters are designed to work only in on-grid mode, so it was important to verify that the team could trick the microinverter to work off-grid as well. To prove this ability with the Enphase M190 microinverter, it was supplied with a DC power supply to represent the solar panels. Once the microinverter was verified to be functioning correctly with just a light bulb load, the microinverter was then connected to the CyberPower UPS. When the power is switched off, the UPS will continue to simulate the grid to the microinverter, keeping it online. This will effectively “fool” the microinverter so the microinverter does not sense a power outage and will continue to supply power to the test loads in off-grid mode. The objective was to have the microinverter powering the loads, while using minimal power from the UPS.

Upon contacting the manufacturer of the Enphase M190 microinverters to inquire about the length of time it takes for the microinverter to shut down once the grid is lost, a representative informed the team that it will take 250ms before the microinverter shuts down. The transfer time for the UPS is only 10ms, therefore the chosen UPS will be more than sufficient in tricking the microinverter to stay online.

5.4.2.2 Procedure

The microinverter outputs 240V line to line and 120V line to neutral. However, to activate the microinverter, a 60Hz, 240V signal is needed. To supply the necessary 240V and 60Hz activation signal, a 1:1 center tap transformer was used to convert 120V AC from the UPS to 240V AC by creating a split phase on the secondary side of the transformer.

The team wanted to verify that the bypass transformer design in Figure 26 would actually work as intended. To do this, the team took measurements to see which winding on the secondary side of the transformer microinverter line 2 needed to be connected to in order to be 180 out of phase with the system busbars to create the 240V needed to turn on the microinverter. After the correct winding was identified, the team turned on the system and verified that the microinverter successfully turned on and that only line 2's power was being pushed through the transformer.

5.4.3 Voltage Sensor Testing

The voltage sensor was first verified in simulation by setting various AC voltages on the input to represent potential voltages on the test setup busbar. The circuit was designed to linearly correlate an

AC input with a DC output. However, at voltage extremes (less than 20V RMS and 200V RMS) the voltage sensor cannot accurately read the busbar voltage due to intentional design limitations in the circuit. This is to prevent damage to the microcontroller input by preventing high voltage inputs. In order to demonstrate the linear relationship and determine the volts per division of the sensor circuit, the following data was plotted from the simulation. The purpose of this simulated data collection was to determine whether the custom voltage sensor would operate as designed. For a table representation of the simulated voltage sensor data, see Appendix F. Figure 35 illustrates the linearity of the designed voltage sensor in the simulation software Multisim, which was then plotted in Microsoft Excel.

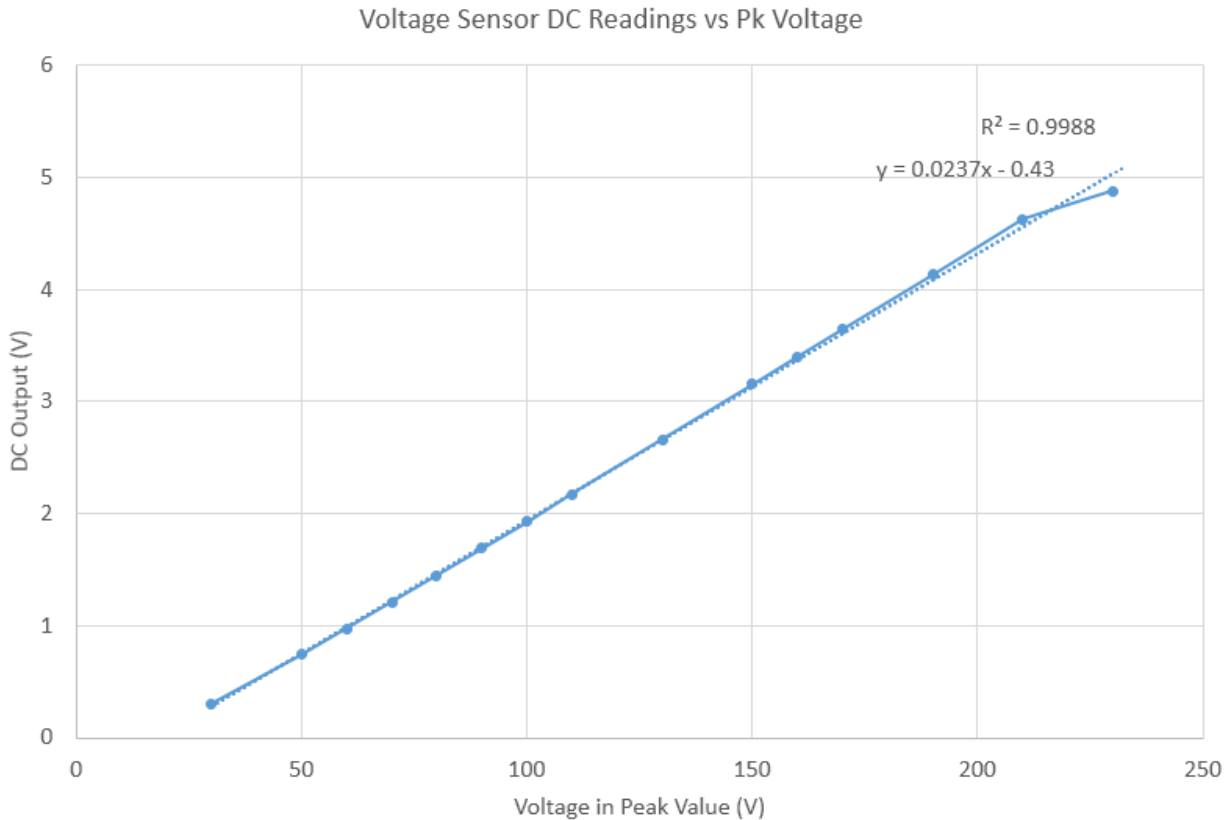

Figure 35. Voltage Sensor Readings

After summing and averaging the volts/div column in Appendix F, the team calculated that 1V AC equals 0.02657VDC (~26.6mV). The simulation provided an accuracy to 5 decimal places. The microcontroller has a minimum read capability of about 4.9mV, which means the sensor will be able to read down to 0.18V AC peak or 0.13V AC RMS. This is an acceptable margin of accuracy because the team is looking for general voltage levels, not precision measurements.

5.4.4 Microcontroller Verification

The purpose of verifying that the microcontroller functions correctly was to ensure the team did not receive a manufacturer's defect and that the microcontroller could properly communicate with a computer. To verify the functionality of the microcontroller, a demo program that came with the software suite was loaded onto the Arduino and the team observed correct functionality.

5.4.5 MOSFET Board Testing

The purpose of verifying the functionality of the MOSFET board before it was integrated into the system was to catch any shorts or poor solder joints and to ensure the MOSFETs functioned properly. The team used a digital multimeter (DMM) to verify continuity of solder joints and continuity of source to drain when 5V was applied to the gate. After all the wiring and components were verified on the board, the board was integrated into the test bed setup.

6.0 Integrated System Testing and Results

6.1 Introduction

Section 6.1 covers the results of the integrated system testing that the team performed. Integrated system testing differs from the component verification which focused on verifying the individual components separately. In integrated system testing, all the various components that comprise the test bed are tested together as a system. Doing this enables the team to test the performance of the microinverter in off-grid mode with the UPS while powering various loads which are controlled by the microcontroller.

6.1 Microinverter Testing Results

To test the microinverter, the procedure in Section 5.4.2.2 was used with a DC power supply operating at 31.2V, which was 3V above the 28V DC the microinverter needed to turn on. The DC supply negative is connected to the microinverter positive and the DC supply is positive connected to the microinverter negative. This configuration was required to turn the microinverter on, as indicated by a series of six green lights about thirty seconds after DC power is applied. It was found that the microinverter did not need the 240V AC signal present to begin its initial startup sequence. Once the 240V AC signal was applied after the microinverter was online, it took five minutes for the microinverter status light to turn yellow which indicated that the microinverter is producing power but is not in contact with its Envoy communication system. However, it was found that if AC power is applied first, then the DC power, the microinverter would turn on in only 1 minute.

Once the microinverter was fully online and producing power, the resulting system waveform can be seen in Figure 36. The blue waveform is the voltage of the microinverter line two and the yellow waveform is Atwater Kent's (AK) voltage waveform.⁶¹ On the microinverter line two, there was some distortion to the waveform, which is possibly due to the microinverter attempting to follow the source waveform but amplifying small distortions it detected.

⁶¹ Atwater Kent is the electrical engineering building at Worcester Polytechnic Institute.

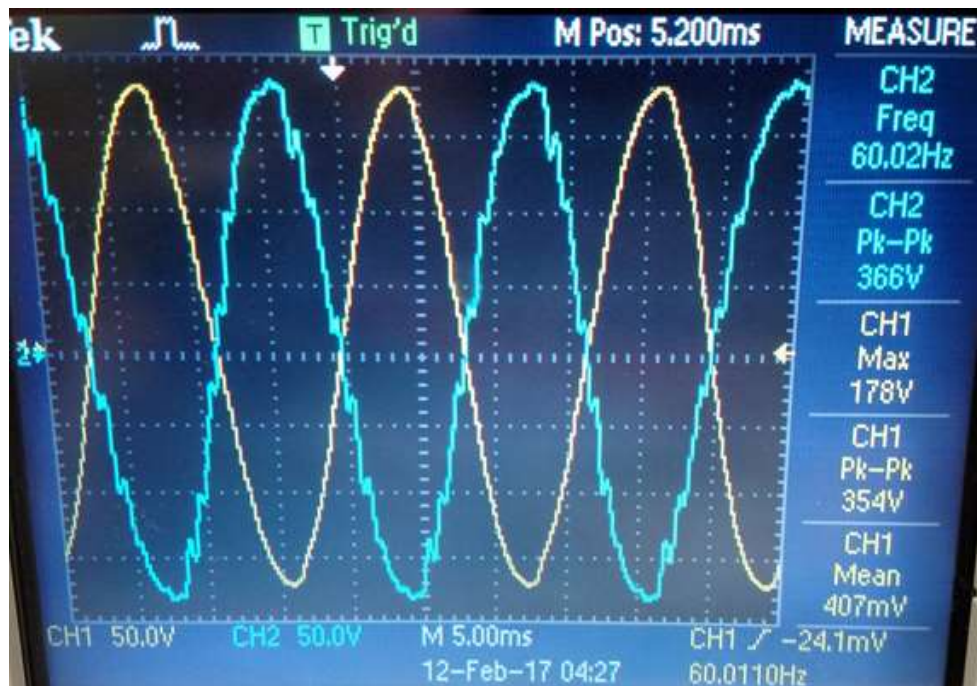

Figure 36. Microinverter Line Two (Blue) and AK (Yellow) Voltage Waveform

6.2 UPS with Microinverter Testing Results

Once the microinverter was fully functioning and turned online, the next step was to test it with the UPS and mimic the failing of the grid. To achieve this, the power to the UPS was shut off with a light switch and the UPS transitioned into battery mode. In battery mode, the UPS supplied the reference signal and waveform for the microinverter to stay online. Figure 37 shows the transition from on-grid to off-grid with microinverter line two in blue and AK in yellow. The system takes about 18ms to recover from the switching, which is circled in red in Figure 37. This time is below the 250ms shut off time of the microinverter.

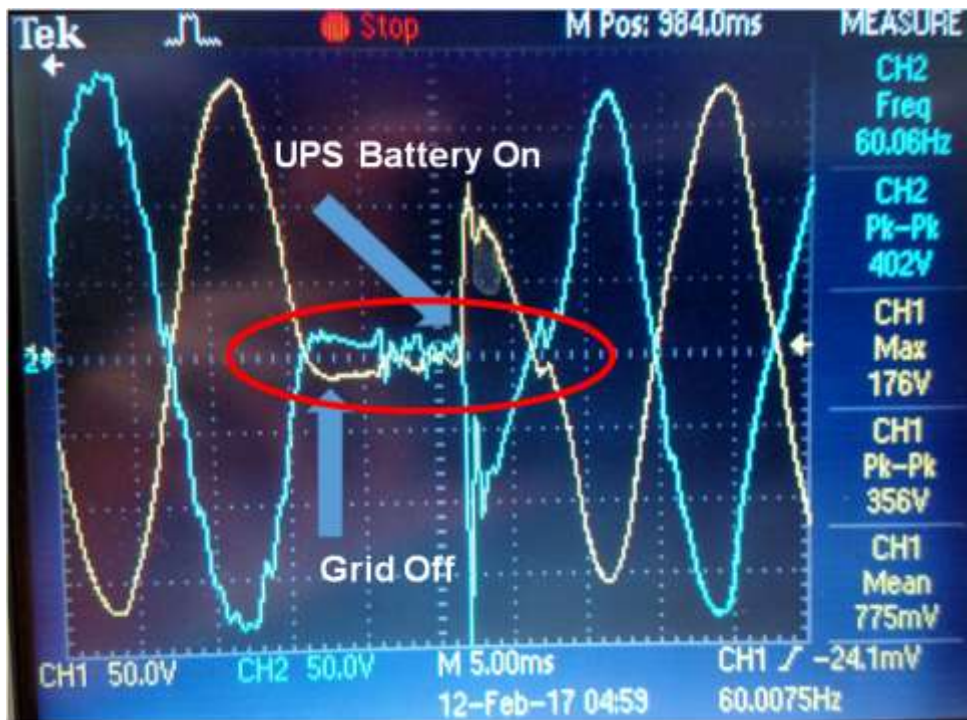

Figure 37. UPS and Microinverter On-Grid to Off-Grid Transition

The team also tested the transition of the microinverter and UPS from off-grid mode to on-grid mode. Testing showed that there was no drop-in power during the off-grid to on-grid transition in Figure 38, and that the UPS was able to almost seamlessly pick up and match the grid waveform with the microinverter following it. However, once the transition back to on-grid is complete, the microinverter begins to experience waveform distortion as seen in the blue waveform. As shown previously in Figure 37, waveform distortion was present during on-grid mode as well before switching to off-grid mode. This seems to be a power quality issue with the grid power in the building used for testing. The yellow waveform is the voltage waveform for AK and the blue waveform is the microinverter. The initial transition to on-grid also shows more pronounced distortion that lasts for about 5ms in Figure 38 below. This is likely an oscillatory transient related to how the UPS switches back to grid mode.

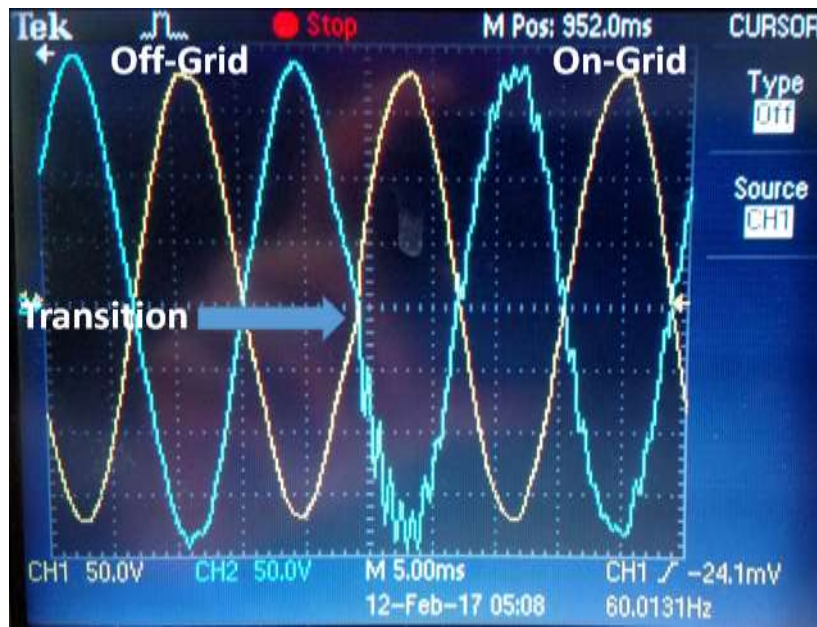

Figure 38. Off-grid to On-grid Transition

6.3 Solar Panel Testing Results

As a DC power supply was used to mimic the solar panel for testing purposes, a 100W solar panel was used to test the system with an actual panel. The solar panel had a $V_{oc} = 22V$ (open circuit voltage) and $I_{sc} = 5.57A$ (short circuit current). This voltage was below the 28V turn on voltage required for the microinverter. Despite this, when placed in full sunlight and connect to just the solar panel, the microinverter began its startup sequence with its status light blinking green and then orange once the 240V AC signal was applied. At this voltage level, the microinverter was able to turn on, but it was not delivering power to the system. The current going into the microinverter was about 2mA while short circuiting the panel resulted in a current of 5.57A. Due to this, it was concluded that the solar panel did not provide a high enough voltage to fully activate the microinverter.

For the next test, two solar panels, a 100W panel and a 20W panel were connected in series to boost the voltage. With the two panels connected in series, the open circuit (OC) voltage was 41.7V, which is above the turn on voltage of 28V. The microinverter was then able to produce power and the panel voltage fluctuated between 36 and 37.5V, likely due to MPPT. There was no noticeable system performance difference between a simulated solar supply (DC power supply) and an actual panel.

6.4 Controller Testing Results

6.4.1 Current Sensor

For the microcontroller to be able to fully observe and record line currents for each load, a current sensor was needed. A sensor was attached to each load line, the microinverter lines, and on the hot line before and after the UPS. If functioning correctly, the current sensors will output a AC waveform that is biased to 2.5V DC. The magnitude of the voltage waveform is directly proportional to the AC current at a ratio of 66mV/A. In order to determine current flow direction, the current sensor analog output was compared to the voltage going through the voltage sensor as shown in Figure 39. If the current waveform was in sync with the voltage, then power is flowing into the UPS from the test bed. If they are 180 degrees out of sync, then power is flowing from the UPS into the test bed. When a load is normally plugged into a wall outlet, the current and voltage waveforms will be 180 degrees apart.

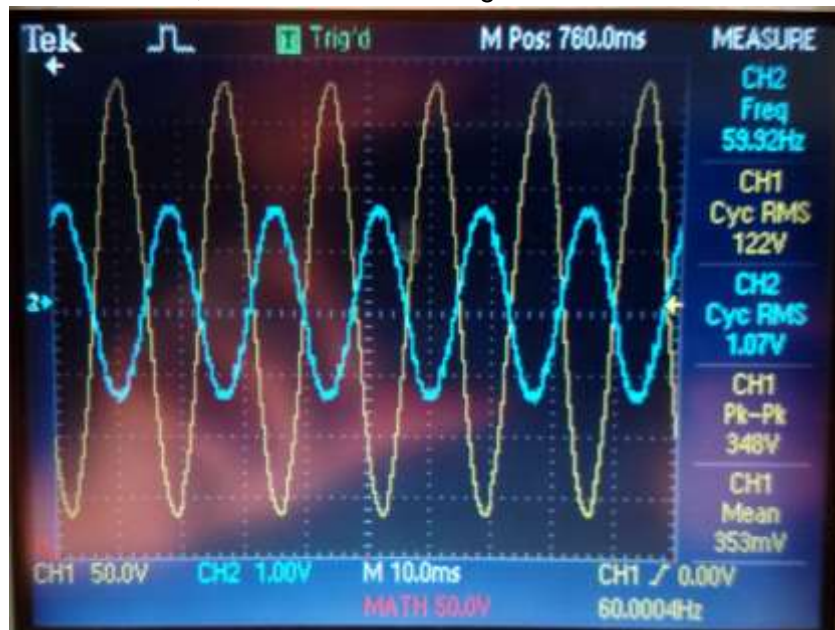

Figure 39. Current vs Voltage Waveforms Pushing Power into Test Bed

With all the light bulbs and the motor turned on, the current sensor measured the current flowing from the grid into the hot busbar (i.e. total system current), and the analog output to the Arduino is shown in Figure 40 where the sinusoidal waveform has a 688mV pk-pk value. Using the oscilloscope, the RMS voltage was 226mV which converts to 3.42A at 66mV/A. In comparison, the Arduino code that converts the signal into an RMS value calculated a current of 3.34A, a difference of 0.08A. The slight difference could likely be due to two factors. The current sensor has an error tolerance of 1.5%, which would equate to 0.05A if the true current was 3.42A. Another source of error could be due to the fact that oscilloscopes are not precise at measuring voltage levels, especially when the voltage is in the mV range. A high precision and calibrated DMM could solve this issue, however one was not readily available to the team and since the discrepancies were small enough to have no real impact on our system performance, the discrepancy was neglected.

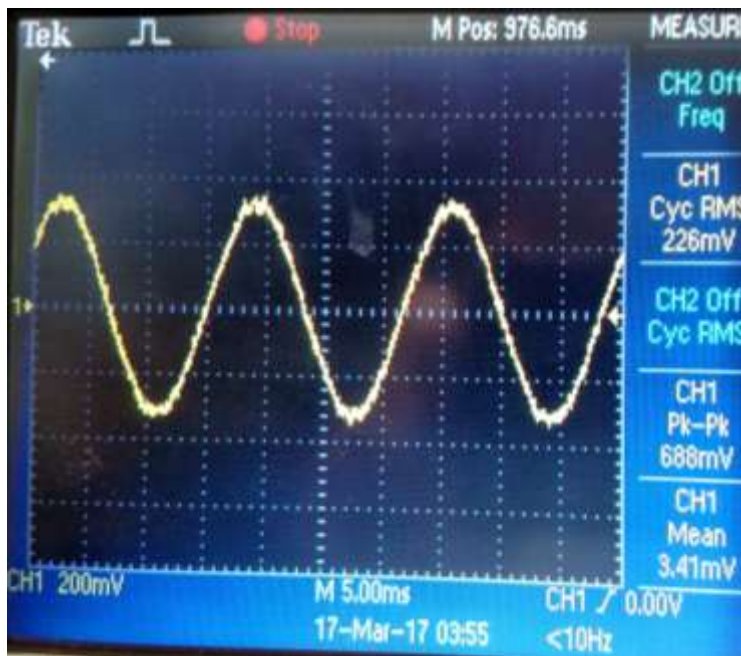

Figure 40. Current Sensor Output Waveform with All Loads On

As the microinverter attempted to push power into the building outlet with no loads as shown in Figure 41, the current sensor voltage waveforms did not always perform as expected and would occasionally show a distorted sine wave with every other cycle being 0A (a flat line). For this setup, two current sensors were used, one reading current flowing into the outlet, and the other reading current flowing from Line 1 of the microinverter output. Figure 41 shows this distortion with the phases of the current being 180 degrees apart. This phase separation indicates that power is flowing in a reversed direction into the outlet instead of from the outlet into the test bed.

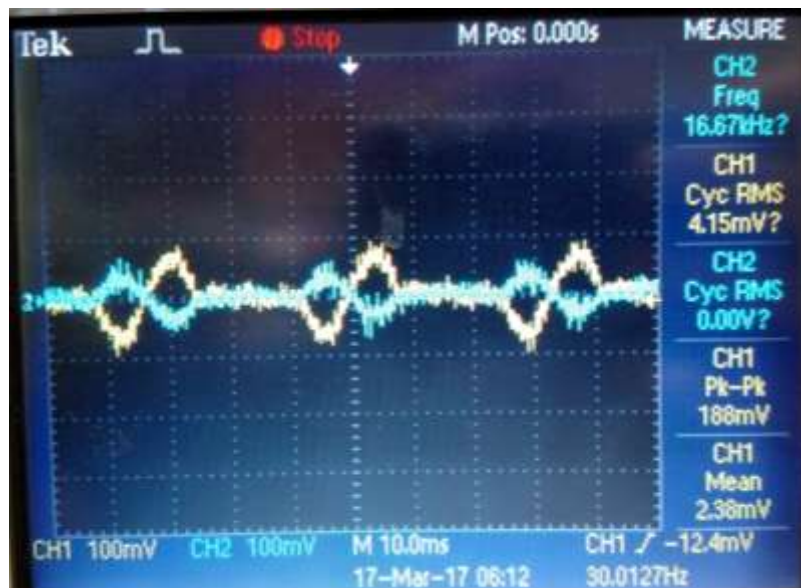

Figure 41. Distorted Current Sensor Waveform When Pushing Power into AK

The waveform in Figure 41 is different than the waveform in Figure 42 because the current sensor waveforms are mostly in phase. The Arduino was measuring 0.45A being transmitted from the microinverter into AK with 0.22A on L1 and 0.23A on L2. The yellow trace shows the current sensor output for the grid connection and the blue trace shows the current sensor output for L2 of the microinverter. In Figure 42, the current waveforms are slightly out of phase because microinverters tend to phase lead slightly so that power draw from local solar power sources is prioritized over grid power. Regardless of how much power the test system drew, the blue microinverter current waveform would always phase lead by the same amount.

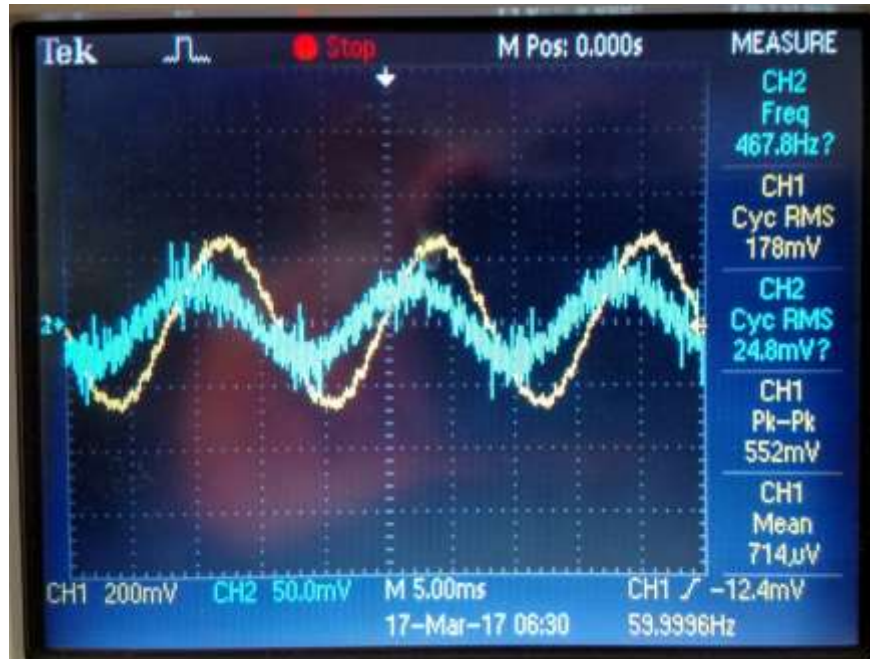

Figure 42. Current Sensors Output Waveform - Mostly in Phase

6.4.2 Voltage Sensor

To calibrate the voltage sensor, the team connected the sensor to an AC outlet on a power strip, and used a multimeter to measure the outlet voltage immediately adjacent to the power strip. The team then adjusted the potentiometer so that 120VAC RMS was close to 5V DC. Figure 43 shows the voltage sensor being read by an NI USB DAQ instead of the chosen Arduino in order to plot voltage fluctuations of the sensor output. This is also why the bias was changed to close to 5V as opposed to 2.5V. At the time of the test, the outlet voltage was 125.5V. The voltage sensor output was about 4.782V DC which was measured using LabVIEW.

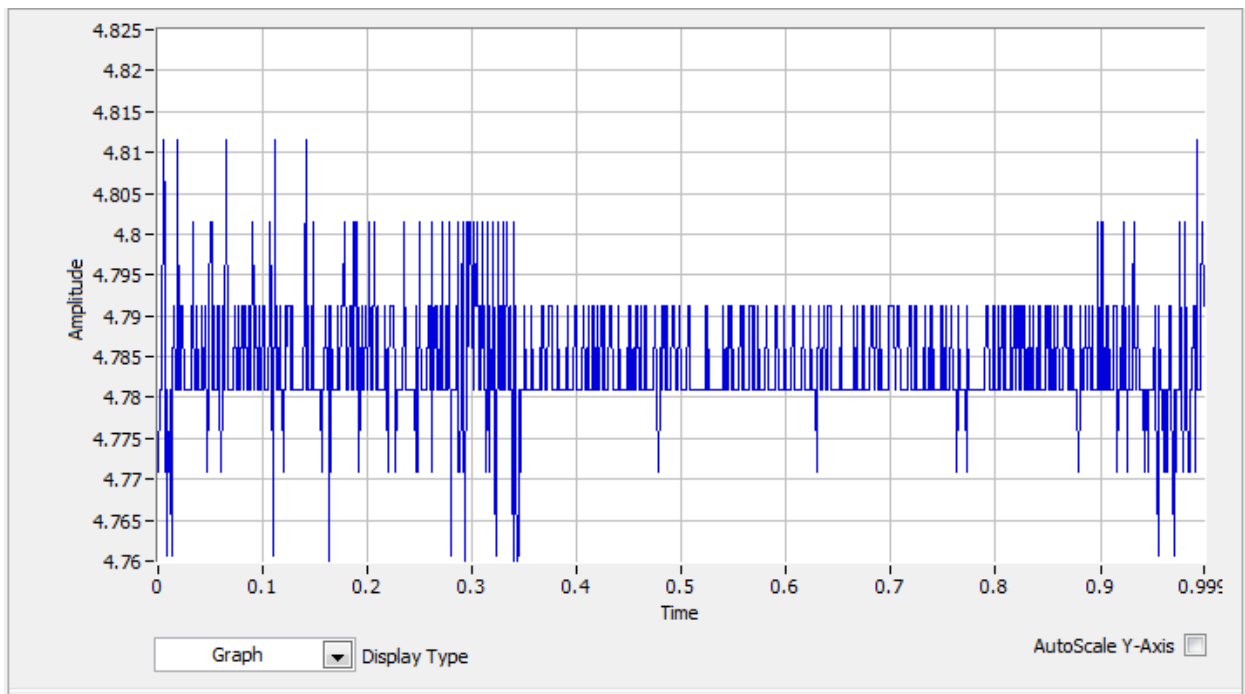

Figure 43. Voltage Sensor Output Graph

To find the volts per division per 1 VAC RMS, the result was $4.782/125.5 = 0.0381\text{V DC}$ per division. Figure 43 shows the real-time grid fluctuations on the microcontroller. These fluctuations in Figure 43 are likely the result of noise on the line, however they typically ranged less than 0.02V DC , which equates to about 0.5V AC when interpreted by the software after applying the scaling factor. This is more than sufficient accuracy for the purposes the team needs the voltage sensor for. These fluctuations could also be due to the transformer used, the unshielded wiring on the protoboard, or various parts slowly warming up. They could also be induced by nearby equipment in the electrical engineering building.

6.4.3 Microcontroller

Once the current sensor and UPS were functioning, the team performed testing on the microcontroller to observe the optimization of the power when in off-grid mode. To detect the loss of the grid, a current sensor measures the input to the UPS and when the measured current becomes zero, the controller knows that grid power has been lost. At this time, the UPS has switched to battery mode, and optimization of the available power begins. Testing of the microcontroller and its associated code in Appendix H demonstrated the ability to optimize loads when in off-grid mode. When in off-grid mode, the program places an artificial limit on the UPS power draw at 15W to limit the UPS battery usage and prolong the system life as without the UPS driving the reference signal, the microinverter would shut off. When optimizing the available power and loads, the program knows the amount of available power and compares it to the loads, and calculates what is the most number of loads that can be supplied with the available power. It then controls the loads by turning the breakers on or off.

6.5 Smart Home Energy Controller Test Results

The team ran all four tests, as mentioned in Section 5.3, and each one performed as expected. Test 1 turned on loads 1 and 2, test 2 turned on loads 1 and 3, and test 3 turned on only load 1. The microcontroller algorithm was able to successfully calculate system power usage and draw from the microinverter and determine the optimal number of loads that could be turned on using the available power. This satisfies test 4 which looked at real time dynamic power allocation, a key feature of the smart home energy controller. The algorithm took into account different load priorities as well, always attempting to turn on the loads in order based on priority, except when a different combination could utilize the available power more efficiently. For example, if there was not enough power for loads 1 and 2, but enough for 1 and 3, it would turn 1 and 3 on and not waste the unused power because there was not enough power to turn on load 2.

6.6 Distortion Source Testing

6.6.1 Transformer Testing

To rule out potential sources of distortion (such as the distortion in Figure 36), the transformer was tested independently using a function generator to determine if the output stage (secondary windings) created any distortion. A function generator was set to 10V peak (the maximum possible with the given equipment) at 60Hz and was connected to the transformer input. The transformer was configured as a 1:1 transformer using an oscilloscope to observe the output. The testing showed that there was no distortion on the transformer output in Figure 44.

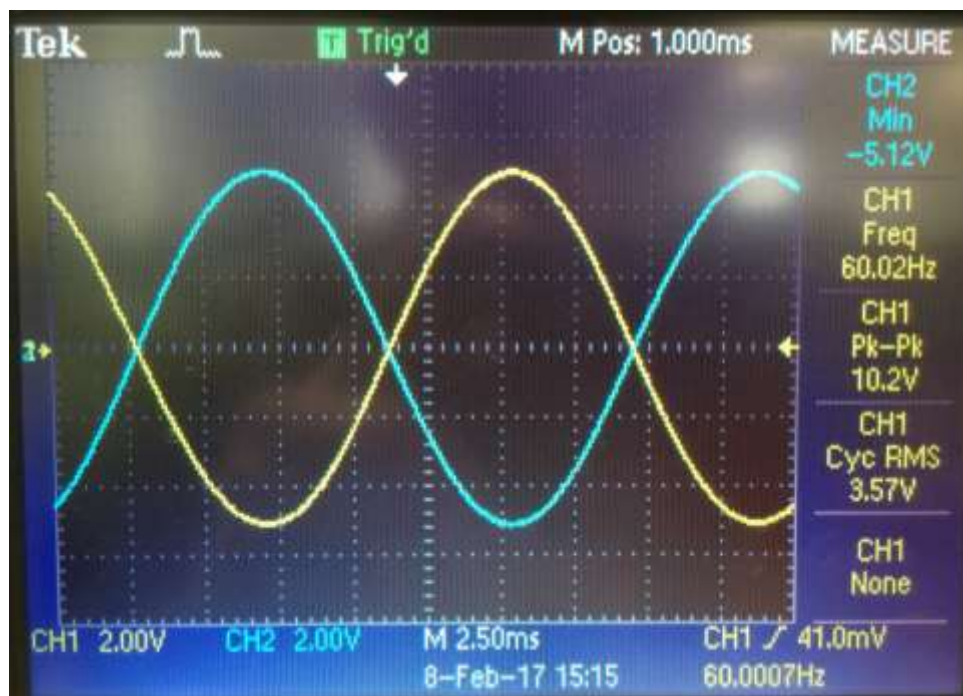

Figure 44. Transformer fed by Function Generator, 10V Peak at 60Hz

6.6.2 Light Bulb Testing

To rule out the light bulbs as a source of distortion, two different types of light bulbs were tested. Both compact fluorescent light bulbs (CFL) and incandescent bulbs were tested. The waveform in blue was that of the bulbs, and yellow was the voltage waveform for AK. Comparing the waveform of the CFL in Figure 45 to the incandescent in Figure 46 shows no noticeable difference even with the incandescent bulb being a pure resistive load while the CFL driver has more advanced electronics.

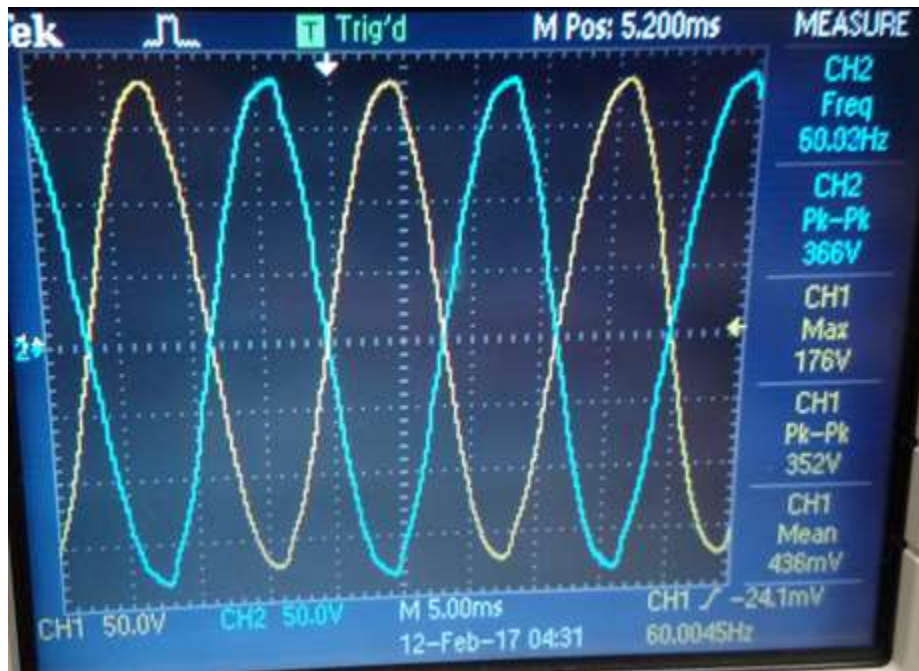

Figure 45. Waveform Comparison - CFL in Blue, AK in Yellow

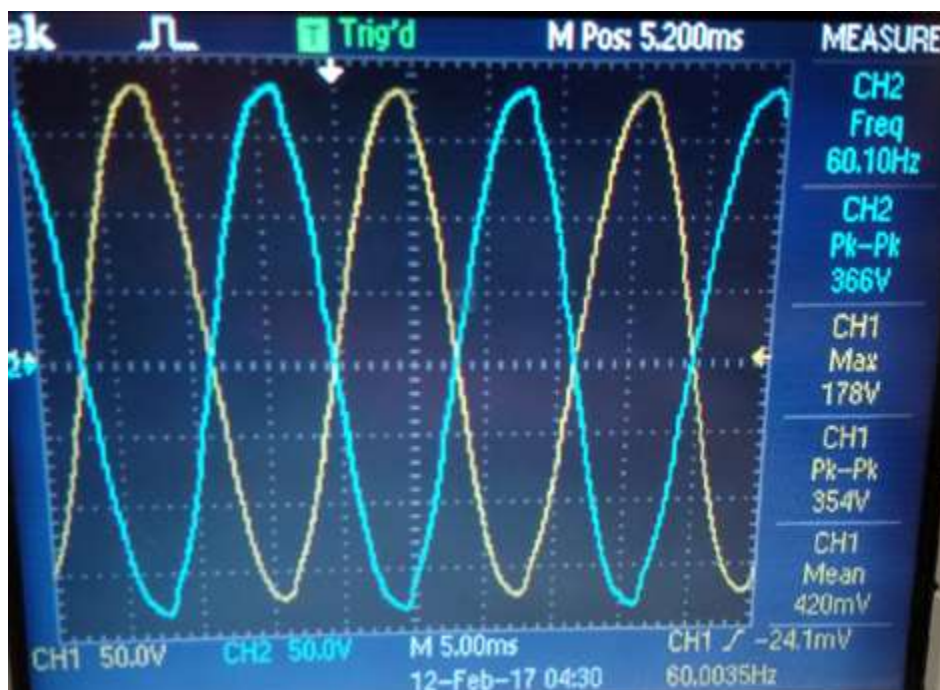

Figure 46. Waveform Comparison - Incandescent in Yellow, AK in Blue

6.7 Transient Testing

Given that the team used incandescent light bulbs, an inductive or capacitive load (such as those found in motors or electronics) may cause adverse effects on a home's electrical system. To test this possibility, a ¼ HP motor was connected to the test bed as a fifth load. The motor used consumes 110W at a voltage of 124.5V. The apparent power of the motor was 310VA. One important condition was that the motor had no load and therefore would have a poor power factor as it was not accomplishing useful work. The motor served as an inductive load to simulate typical house motors. During on-grid mode, when the motor initially turned on, there was a small voltage sag that the system then recovered from and is shown below in Figure 47 in the red circle. The voltage sag lasted for approximately 250ms. The sag was minimal (only 3-5V) and barely affected the system. Upon zooming in at the time when the motor kicked on, the team was unable to find any sort of transients or voltage waveform distortions.



Figure 47. On-Grid Voltage Sag Caused by Motor Operation

During off-grid mode, the voltage sag caused by the motor was much more pronounced and can be clearly seen in Figure 48. This voltage sag lasted for about 330ms, which was slightly longer than in on-grid mode at about 250ms. Based on these results, it can be concluded that the microinverter and UPS combo cannot compensate as well as the grid can in regards to an inductive motor turning on. Therefore, power factor correction may be necessary if microinverters and battery backup were used in a home to compensate for inductive loads.

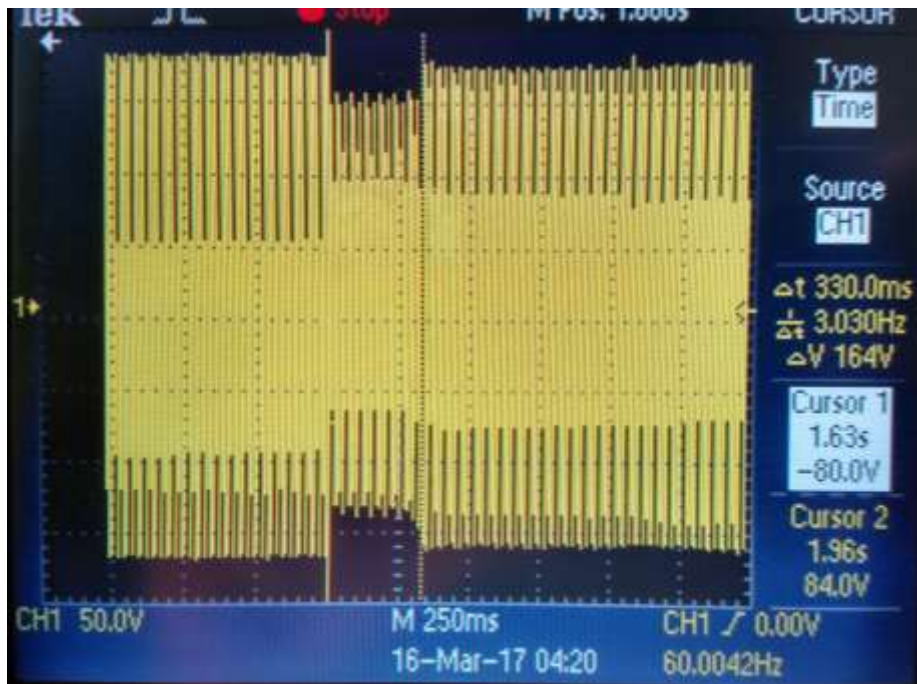

Figure 48. Off-Grid Voltage Sag Caused by Motor Operation

A more detailed view of the off-grid voltage sag caused by the motor operation can be seen in Figure 49. The system voltage sags to about 104.6V RMS which is a 16V drop from standard (120V) for nearly 330ms in this trial. In both on-grid and off-grid testing, there were no switching transients observed with using a light switch to turn on or off the motor (see Figure 20 in Section 2.9 for an example of a switching transient).

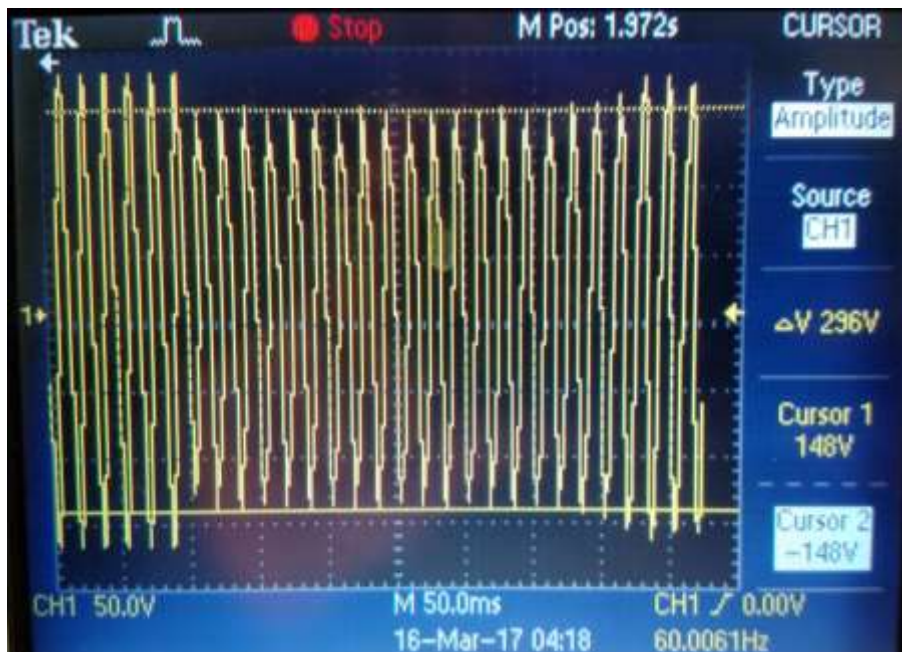

Figure 49. Off-Grid Voltage Sag Closeup Due to Motor Operation

Another aspect of transient testing the team performed was oscillatory (switching) transient testing in regards to the electronically controlled breakers. The purpose of this test was to determine if the electronically controlled breakers produced any voltage transients when the switch makes contact with the copper conductor internally. While no switching transients were predicted because the loads used were the purely resistive loads, the team wanted to verify this assumption. As shown in Figure 50, there were no observable transients when the electronically controlled breaker engages. In off-grid mode, the team observed similar results.



Figure 50. Electronic Breaker Transient Testing - Breaker Closing and Restoring Power

6.8 Results Summary

Using the designs the team came up with in Sections 4 and 5, the team build the test bed shown in Figure 30. The test bed included key components such as electronically controlled breakers, a microinverter, a 120/240 transformer, current sensors, a microcontroller, light bulb loads, and DC power supplies. The team recorded measurements of the voltages and currents of the system under varying conditions, such as on-grid mode, off-grid mode, and the transition between both states. The team discovered that during off-grid mode, if the microinverter output more power than the loads consumed the system would destabilize, causing the microinverter to shut down. The team also discovered that during on-grid mode, when the microinverter was pushing power into the building there were waveform distortions between the microinverter and the utility grid shown in Figure 41. Another interesting result was that the microinverter would amplify small distortions in the grid signal as shown in Figure 36 which was unexpected. Additionally, the team found that the microinverter and UPS were not able to compensate for poor power factor when a $\frac{1}{4}$ HP motor was turned on, which is important for off-grid use since the utility connection is not there to help compensate. Ultimately though, the team was successful in demonstrating dynamically controlled reconfigurable loads through electronic breakers along with measuring real time power usage per line with a microcontroller to determine available power levels and loads being used. These were the two critical features of the smart home energy controller which helps enable homeowners to use their solar off-grid. However, improvements would have to be made in order to make the system more stable and suitable for in home use.

7.0 Conclusion

One of the challenges facing homeowners with solar PV systems is the inability to use their solar system during a power outage and a lack of smart power optimization. In this project, the team designed a prototype system that demonstrated a home microgrid architecture, which enabled a solar PV system to work in off-grid mode, creating a hybrid grid tie system. The smart home energy controller contained a microcontroller that optimized the available power while off-grid and the team demonstrated a potential model for using microinverters in an off-grid or hybrid grid tie application. To design the system, the team performed background research, defined the problem, analyzed various system constraints, developed use cases, and identified stakeholder needs. Then the system was designed and tested with results demonstrating the use of a microinverter and UPS in managing an off-grid solar system.

As the solar industry moves more toward microinverters, this report outlines a possible way to implement hybrid grid tie solar systems with added features such as dynamic power allocation and software load prioritization. The smart home energy controller would need further modification though to become a feasible, more stable method of implementation and potential product.

Some of the key findings were:

1. Microinverters are not suitable for off-grid solar systems as the microinverters will attempt to follow a reference signal and in the absence of the grid the microinverters need a UPS or a battery based inverter to follow.
2. In a typical off-grid system, design can be challenging as an excess load bank is needed to absorb excess solar generation, otherwise the microinverter will go offline.
3. Microinverters can amplify grid distortions as was shown in Figure 36. When designing a system that can work off-grid as well as on-grid, it is imperative to manage loads and transients to keep the voltage waveform as clean as possible.
4. Electronically controlled breakers can have a new application in home microgrid power management in off-grid or limited power scenarios, such as when grid power is offline and your residential solar system isn't designed to fully sustain your home in off-grid mode.
5. It is possible to use a UPS or other pure sine wave source to "trick" an inverter to stay online even when the grid is not online.
6. Off-grid microinverters need some device that will perform power factor correction because the test results showed waveform distortions and significant power factor reduction when a motor was used with no load. Microinverters and UPSs do not sufficiently correct for poor power factor because they are not designed to correct it.
7. A microinverter based hybrid grid tie system is possible, but the approach the team used would need modification to include power factor correction and a larger battery storage capacity to enable the system to last longer in off-grid mode. Currently, the UPS battery size is the main limitation to how long the system can deliver power in off-grid mode.

Appendices

Appendix A. Color Coded System Level Functional Block Diagram (Power)

Appendix A is a colored version of the system level functional block diagram that highlights both AC and DC power flows in the smart home energy controller.

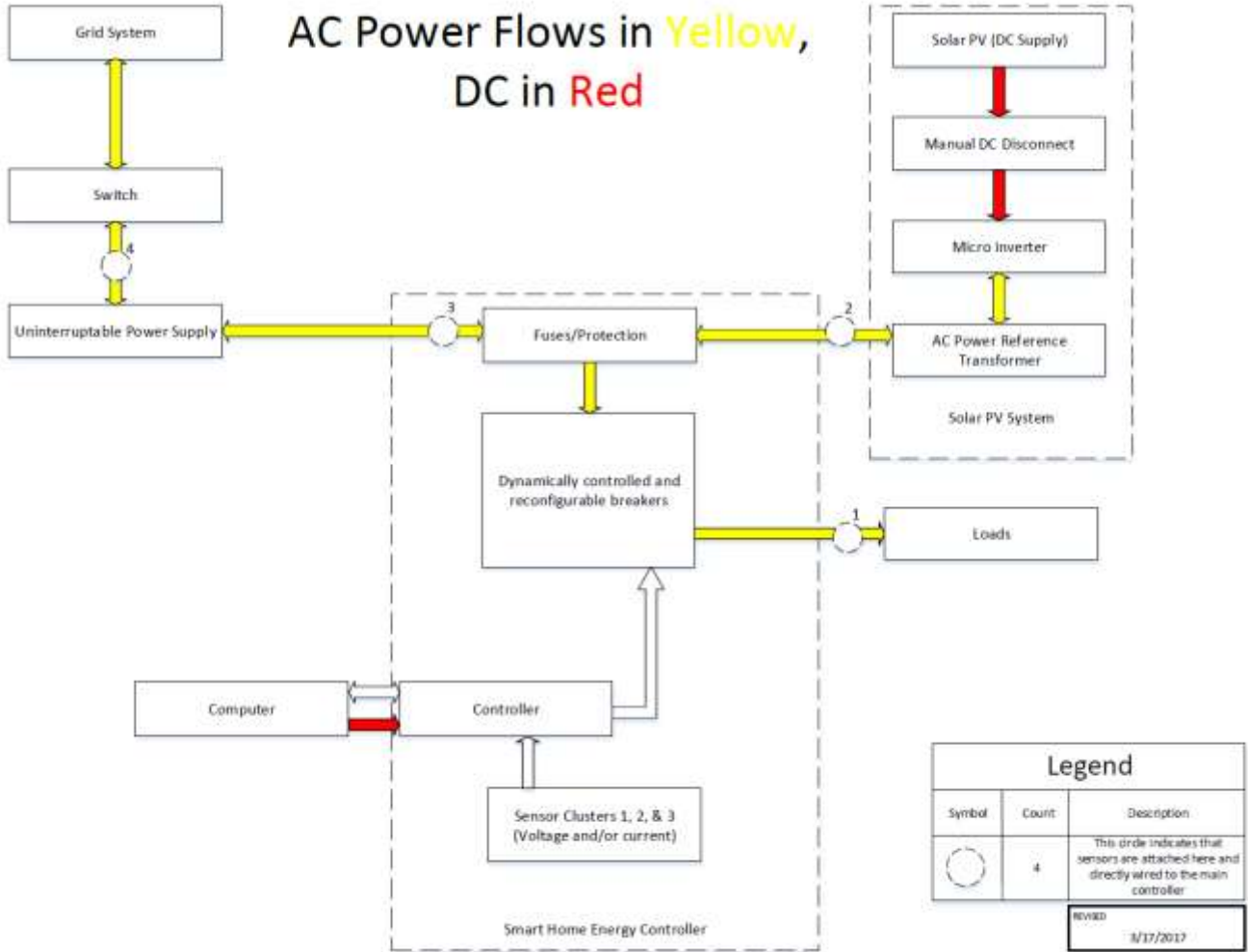

Appendix B. Color Coded System Level Functional Block Diagram (Data)

Appendix B is a colored version of the system level functional block diagram that highlights data communications in the smart home energy controller. The only data communications in the controller are between the computer and microcontroller.

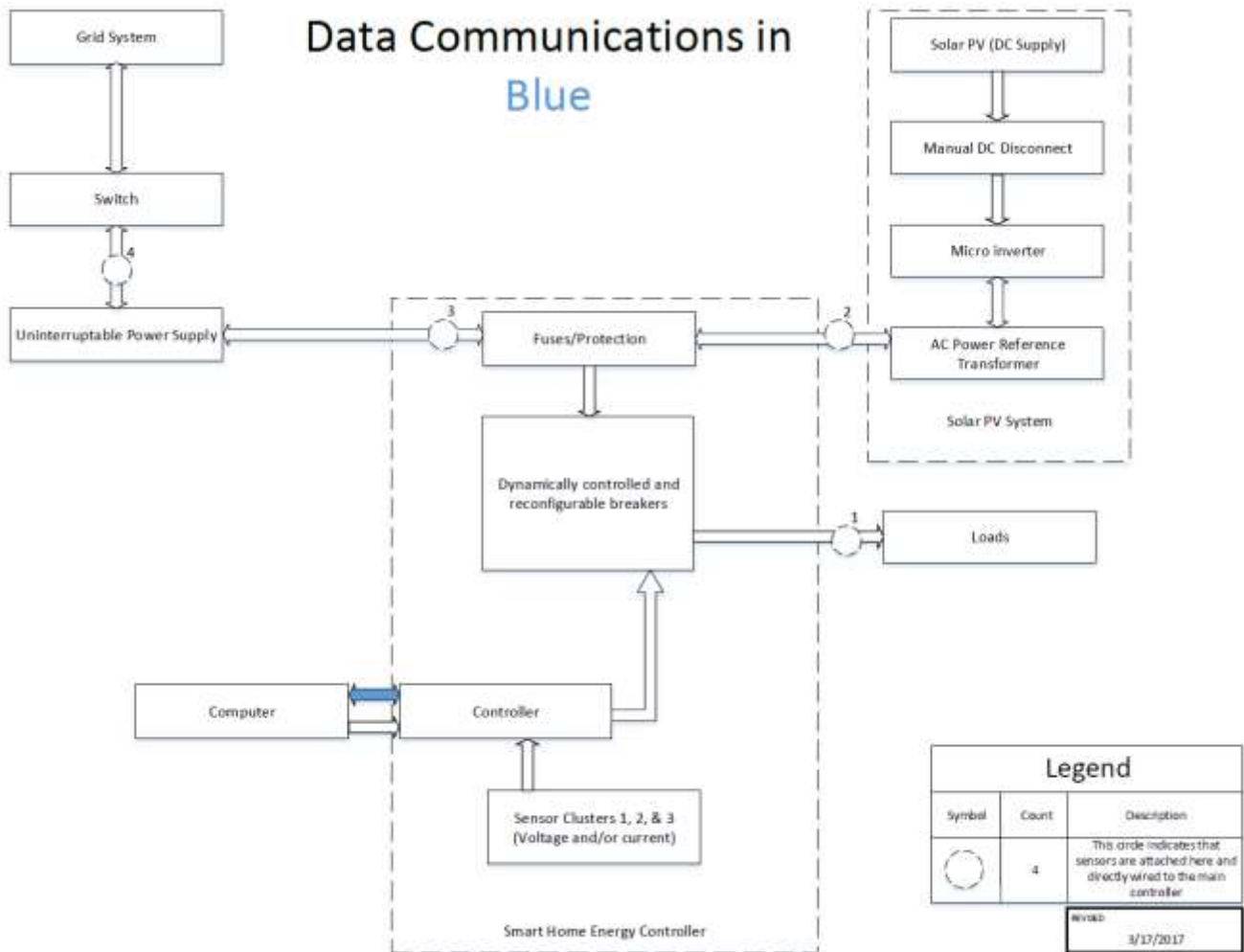

Appendix C. Color Coded System Level Functional Block Diagram (Signals)

Appendix C is a colored version of the system level functional block diagram that highlights the signal flows in the smart home energy controller. Signals will flow from the sensor cluster which is comprised of the current sensors and the voltage sensor to the controller reporting back real time measurements.

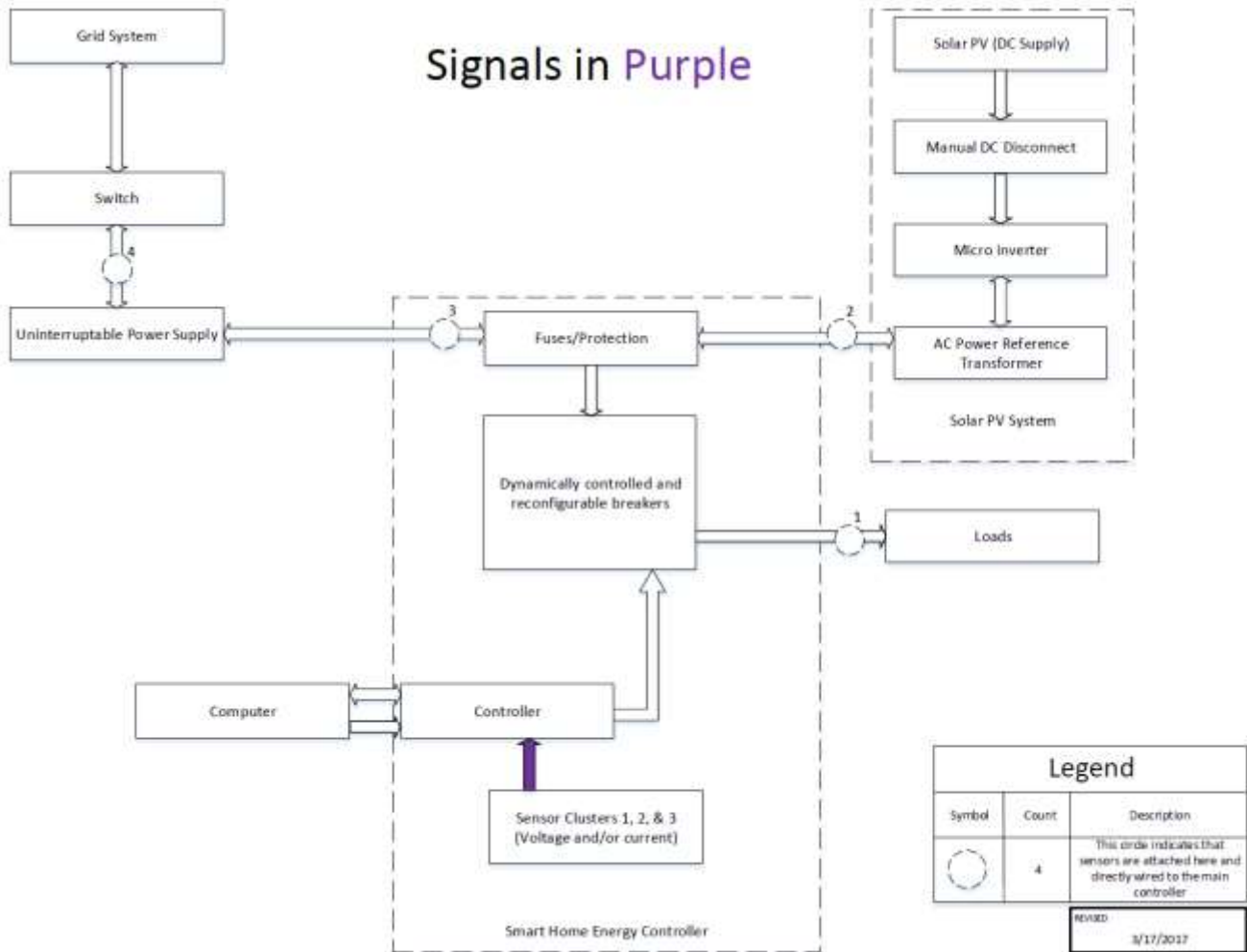

Legend		
Symbol	Count	Description
	4	This circle indicates that sensors are attached here and directly wired to the main controller
REVISED 3/17/2017		

Appendix D. Zoomed in UPS Transfer Time

Appendix D shows a zoomed in transfer from grid to battery for the CyberPower UPS and the transfer time which is about 16ms as each division is 2ms.



Appendix E. Simulation Oscillogram for Voltage Sensor

Appendix E shows a simulated voltage sensor output based off of a model developed in Multisim. As shown in the Figure, the voltage sensor output is very stable, minimizing noise and inaccuracies in the sensor reading.

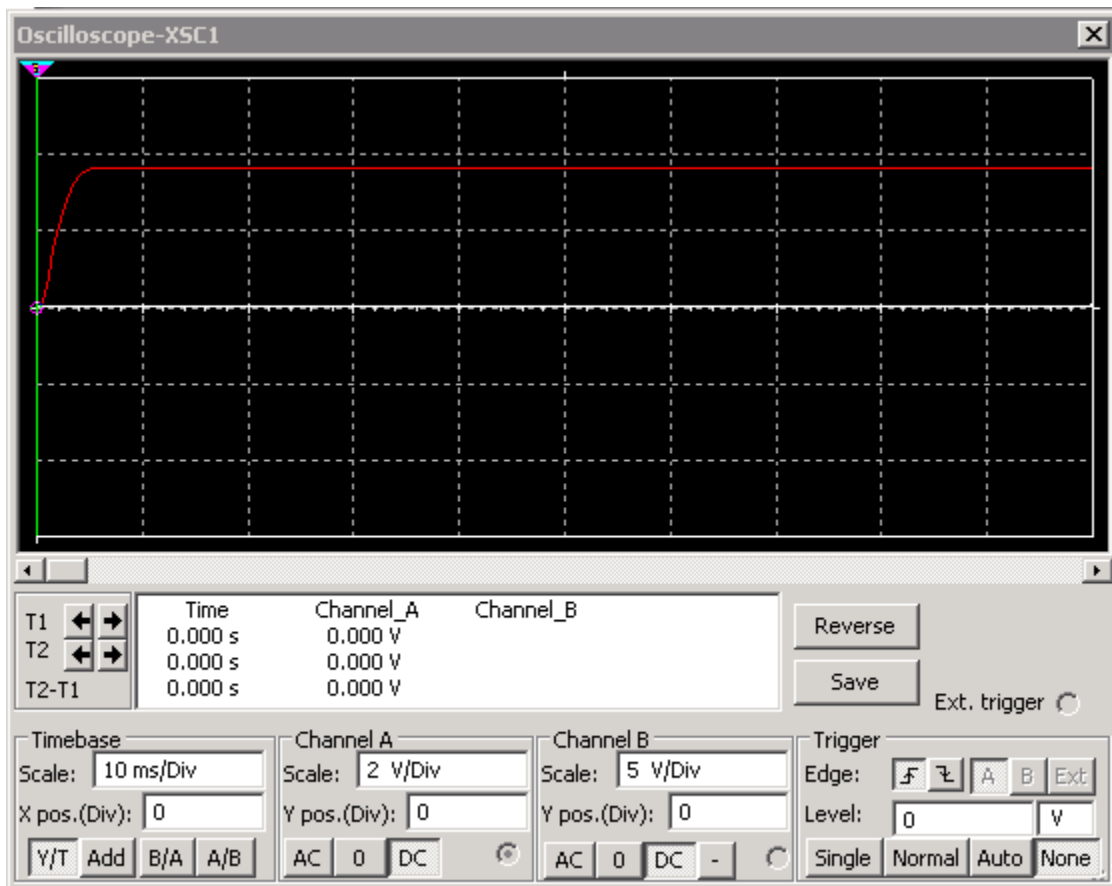

Appendix F. Linearity of Voltage Sensor

Appendix F shows simulation data at various peak AC voltage values and what DC values they correspond with. This data is using a 10V range, which can be easily reduced to 5V using a resistor based voltage divider. This data is used to plot the linearity and overall quality of the voltage sensor designed based off of simulated data. The median voltage deviation was around 3mV, which is almost exactly the resolution of the Arduino Mega used at 4.9mV. This means the voltage sensor will be fairly accurate.

Simulation Data for Voltage Sensor

Pk Value	DC Value	Volts/Div	Deviation
270	8.399	0.031107	0.015
250	7.72	0.03088	0.012
230	7.042	0.030617	0.01
210	6.36	0.030286	0.008
190	5.685	0.029921	0.006
170	5.001	0.029418	0.005
160	4.67	0.029188	0.005
150	4.33	0.028867	0.004
130	3.658	0.028138	0.003
110	2.986	0.027145	0.002
100	2.648	0.02648	0.003
90	2.314	0.025711	0.001
80	1.98	0.02475	0.001
70	1.652	0.0236	0.001
60	1.329	0.02215	0.001
50	1.01	0.0202	0.001
30	0.399	0.0133	0.001

Appendix G. Wiring Diagram for BABRP1020 Breaker

Appendix G is the wiring diagram for the electronically controlled breakers used in the smart home energy controller. The breaker is composed of two sub-breakers, a manual breaker and an electronic breaker. For safety, the electronic breaker cannot override the manual breaker and is controlled with a 24V DC signal.

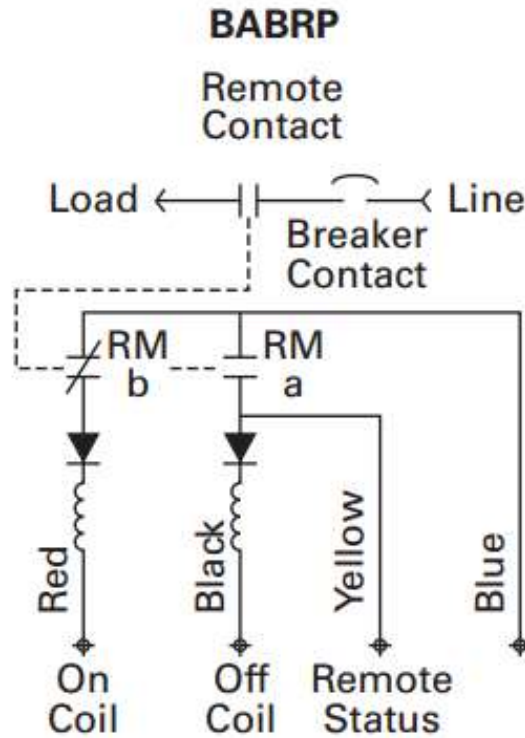

Source: Eaton. (2013, August). *Industrial Circuit Breakers*. Retrieved from *Miniature Circuit Breakers and Supplementary Protectors*: <https://s3.amazonaws.com/cesco-content/unilog/Batch4/782116/13776-AttachmentURL.pdf>

Appendix H. Arduino Optimization Code

Appendix H is the code for the microcontroller that is used to control the smart home energy controller. It will control the loads through the electronically controlled breakers and when it detects an outage, it will optimize for the maximum amount of loads it can keep online and switch them on. The optimization is based on the power of the loads before the outage and is calculated with data from the current and voltage sensors.

```
double getvoltage;
double voltage;
double RMSvoltage;
double current[7];
double trueamps1 = 0;
double trueamps2 = 0;
double trueamps3 = 0;
double trueamps4 = 0;
double trueamps5 = 0;
double trueamps6 = 0;
double trueamps7 = 0;
double trueamps8 = 0;
double availablepower = 0;
double availablepower1 = 0;
double availablepower2 = 0;
float loadpower[3];
bool offgrid = false;
bool donothing = false;
bool alreadyoffgrid = false;
bool loadon[3]; //where loadon[0] =
30w load 1, loadon[1] = 30w load 2,
loadon[2]=72w load 1, loadon[3]=72w
load 2
bool load4alreadyon = true;
double testpower;
int availablepowercount = 0;

const unsigned long sampleTime =
100000UL; //sample over 100ms in order
to 6 cycles of AC waveform
const unsigned long numSamples =
250UL; //choose the number of samples
to take along the waveform, should be
over twice the nyquist rate
const unsigned long sampleInterval =
sampleTime / numSamples; //the
sampling interval
const int adc_zero = 512; //This is
needed to set the 2.5V bias of the

current sensor to "0" so to speak

/*
A0 = voltage sensor
A1=current sensor into UPS
A2=current from UPS
A3=microinverter current L1
A4=30w load 1 D36/37
A5=30wload 2 D34/35
A6=72w load 1 D=24/25
A7=72w load 2 = D22/23
A8=current into/from transformer
(L2 from microinverter essentially)
*/

void setup() {
  Serial.begin(9600);
  pinMode(22, OUTPUT);
  pinMode(23, OUTPUT);
  pinMode(24, OUTPUT);
  pinMode(25, OUTPUT);
  pinMode(34, OUTPUT);
  pinMode(35, OUTPUT);
  pinMode(36, OUTPUT);
  pinMode(37, OUTPUT);
  loadon[0] = true;
  loadon[1] = true;
  loadon[2] = true;
  loadon[3] = true;
}

void loop() {
  double storeRMSvoltage;
  getvoltage = analogRead(0);
  voltage = getvoltage * 0.0049;
  //Serial.print("DC voltage: ");
  //Serial.print(voltage);
  RMSvoltage = ((voltage / 0.0199));
  storeRMSvoltage = RMSvoltage + 3.5;
  Serial.print("AC RMS Voltage: ");
```

```

Serial.println(RMSvoltage);

CurrentSense1();
trueamps1 = current[0] / 66;
//convert to Amps given 0.066mV/A
division
Serial.print("Current into UPS: ");
Serial.println(trueamps1);
//determine if grid is offline
if (0.1 >= trueamps1)
    offgrid = true;
else {
    offgrid = false;
    alreadyoffgrid = false;
}
CurrentSense2();
trueamps2 = ((current[1] / 66));
Serial.print("Current from UPS: ");
Serial.println(trueamps2);
CurrentSense3();
trueamps3 = (current[2] / 66);
Serial.print("microinverter current
L1: ");
Serial.println(trueamps3);
CurrentSense4();
trueamps4 = current[3] / 66;
Serial.print("30w load 1 D36/37: ");
Serial.println(trueamps4);
CurrentSense5();
trueamps5 = current[4] / 66;
Serial.print("30w load 2 D34/35: ");
Serial.println(trueamps5);
CurrentSense6();
trueamps6 = current[5] / 66;
Serial.print("72w load 1 D=24/25:
");
Serial.println(trueamps6);
CurrentSense7();
trueamps7 = ((current[6] / 66) -
0.03);
Serial.print("72w load 2 = D22/23:
");
Serial.println(trueamps7);
CurrentSense8();
trueamps8 = current[7] / 66;
Serial.print("current into/from
transformer: ");
Serial.println(trueamps8);

```

```

/*
//calculate load powers. This code
is currently not used but could be
implemented depending on desired
algorithm
    loadpower[0] = RMSvoltage *
trueamps4;
    loadpower[1] = RMSvoltage *
trueamps5;
    loadpower[2] = RMSvoltage *
trueamps6;
    loadpower[3] = RMSvoltage *
trueamps7;
*/

Serial.print("Offgrid mode: ");
Serial.println(offgrid);
//calculate available power
if (offgrid == false) {
    if (availablepowercount < 1) {
        availablepower1 =
((storeRMSvoltage * trueamps3) +
(storeRMSvoltage * trueamps8));
        availablepowercount = 1;
        if (availablepower1 < 20)
            availablepower1 = 0;
        Serial.print("Power from
microinverter: ");
        Serial.print(availablepower1);
        Serial.println("w");
    }
    else {
        availablepower2 =
((storeRMSvoltage * trueamps3) +
(storeRMSvoltage * trueamps8));
        availablepowercount = 0;
        if (availablepower2 < 20)
            availablepower2 = 0;
        Serial.print("Power from
microinverter: ");
        Serial.print(availablepower2);
        Serial.println("w");
    }
}

if (loadon[0] == false) {
    digitalWrite(37, HIGH);
    delay(200);
}

```

```

    digitalWrite(37, LOW);
    loadon[0] = true;
    Serial.println("turning load
back on");
}
if (loadon[1] == false) {
    digitalWrite(35, HIGH);
    delay(200);
    digitalWrite(35, LOW);
    loadon[1] = true;
}
if (loadon[2] == false) {
    digitalWrite(25, HIGH);
    delay(200);
    digitalWrite(25, LOW);
    loadon[2] = true;
}
Serial.print("loadon[3]: ");
Serial.println(loadon[3]);
Serial.print("load4alreadyon: ");
Serial.println(load4alreadyon);
if (loadon[3] == true) {
    if (load4alreadyon == false) {
        digitalWrite(23, HIGH);
        delay(200);
        digitalWrite(23, LOW);
        loadon[3] = true;
        load4alreadyon = true;
    }
}

//availablepower = 70;
if (availablepower1 > 115) //check
in case of a rare case where it could
be higher than physically possible
    availablepower1 = 115;
/*
    if (offgrid==true){
    if (trueamps2>0.125)
        availablepower = ((RMSvoltage *
trueamps3) + (RMSvoltage * trueamps8)
- (RMSvoltage * trueamps2));
    /*
        else if (trueamps2<0.125){
            if (loadon[0] = false &&
loadon[1] = false && loadon[2] = false
&& loadon[3] = false){
                //try turning on one load
                    digitalWrite(36, HIGH);
                    delay(200);
                    digitalWrite(36, LOW);
                    loadon[0] = true;
                    CurrentSense2();
                    trueamps2=current/66;
                    if (trueamps2>0.125){ //turn
the load back off, not enough power
                        digitalWrite(37, HIGH);
                        delay(200);
                        digitalWrite(37, LOW);
                        loadon[0] = false;
                    }
                }
                if (loadon[0] = true &&
loadon[1] = false && loadon[2] = false
&& loadon[3] = false){
                    }
                }
            }
        }
    */
    //semi-dumb optimization algorithm
    if (offgrid == true) {
        /* 30w load 1 is priority 1
        30w load 2 is priority 3
        72w load 1 is priority 2
        72w load 2 is priority 4
        A4=30w load 1 D36/37
        A5=30w load 2 D34/35
        A6=72w load 1 D=24/25
        A7=72w load 2 = D22/23
        */
        if (alreadyoffgrid == false) {
            //turn off all loads temporarily
            digitalWrite(22, HIGH);
            delay(50);
            digitalWrite(24, HIGH);
            delay(50);
            digitalWrite(22, LOW);
            digitalWrite(34, HIGH);
            delay(50);
            digitalWrite(24, LOW);
            digitalWrite(36, HIGH);
            delay(50);
            digitalWrite(34, LOW);

```

```

delay(50);
digitalWrite(36, LOW);
loadon[0] = false;
loadon[1] = false;
loadon[2] = false;
loadon[3] = false;
}

if (alreadyoffgrid == false) {
  if (availablepowercount == 0) {
    if (availablepower1 > 25) {
      digitalWrite(37, HIGH);
      delay(50);
      digitalWrite(37, LOW);
      loadon[0] = true;
      if (availablepower1 > 98) {
        digitalWrite(25, HIGH);
        delay(50);
        digitalWrite(25, LOW);
        loadon[2] = true;
      }
      else if (availablepower1 >
55) {
        digitalWrite(35, HIGH);
        delay(50);
        digitalWrite(35, LOW);
        loadon[1] = true;
      }
    }
  }
  else {
    if (availablepower2 > 25) {
      digitalWrite(37, HIGH);
      delay(50);
      digitalWrite(37, LOW);
      loadon[0] = true;
      if (availablepower2 > 98) {
        digitalWrite(25, HIGH);
        delay(50);
        digitalWrite(25, LOW);
        loadon[2] = true;
      }
      else if (availablepower2 >
55) {
        digitalWrite(35, HIGH);
        delay(50);
        digitalWrite(35, LOW);
        loadon[1] = true;
      }
    }
  }
}

//Current sensor code based on code
from user DheerajKhajuria on
github.com
void CurrentSense1() //current sensor
for power into UPS
{
  unsigned long currentAcc = 0;
  unsigned int count = 0;
  unsigned long prevMicros = micros()
- sampleInterval ;
  while (count < numSamples)
  {
    if (micros() - prevMicros >=
sampleInterval)
    {
      int adc_raw = analogRead(1) -
adc_zero;
      currentAcc += (unsigned
long)(adc_raw * adc_raw);
      ++count;
      prevMicros += sampleInterval;
    }
  }

  double rms = sqrt((float)currentAcc
/ (float)numSamples) * (50 / 1024.0);
  rms = ((rms - 0.04) * 100);

  current[0] = rms;
}

void CurrentSense2() //current from
UPS
{
  unsigned long currentAcc = 0;
  unsigned int count = 0;
  unsigned long prevMicros = micros()
- sampleInterval ;
  while (count < numSamples)

```

```

    {
        if (micros() - prevMicros >=
sampleInterval)
        {
            int adc_raw = analogRead(2) -
adc_zero;
            currentAcc += (unsigned
long)(adc_raw * adc_raw);
            ++count;
            prevMicros += sampleInterval;
        }
    }

    double rms = sqrt((float)currentAcc
/ (float)numSamples) * (50 / 1024.0);
    rms = ((rms - 0.04) * 100);

    current[1] = rms;
}

void CurrentSense3() //microinverter
current L1
{
    unsigned long currentAcc = 0;
    unsigned int count = 0;
    unsigned long prevMicros = micros()
- sampleInterval ;
    while (count < numSamples)
    {
        if (micros() - prevMicros >=
sampleInterval)
        {
            int adc_raw = analogRead(3) -
adc_zero;
            currentAcc += (unsigned
long)(adc_raw * adc_raw);
            ++count;
            prevMicros += sampleInterval;
        }
    }

    double rms = (sqrt((float)currentAcc
/ (float)numSamples) * (50 / 1024.0));
    rms = ((rms - 0.02) * 100);

    current[2] = rms;
}

void CurrentSense4() //30w load 1

```

```

D36/37
{
    unsigned long currentAcc = 0;
    unsigned int count = 0;
    unsigned long prevMicros = micros()
- sampleInterval ;
    while (count < numSamples)
    {
        if (micros() - prevMicros >=
sampleInterval)
        {
            int adc_raw = analogRead(4) -
adc_zero;
            currentAcc += (unsigned
long)(adc_raw * adc_raw);
            ++count;
            prevMicros += sampleInterval;
        }
    }

    double rms = sqrt((float)currentAcc
/ (float)numSamples) * (50 / 1024.0);
    rms = ((rms - 0.04) * 100);

    current[3] = rms;
}

void CurrentSense5() //30w load 2
D34/35
{
    unsigned long currentAcc = 0;
    unsigned int count = 0;
    unsigned long prevMicros = micros()
- sampleInterval ;
    while (count < numSamples)
    {
        if (micros() - prevMicros >=
sampleInterval)
        {
            int adc_raw = analogRead(5) -
adc_zero;
            currentAcc += (unsigned
long)(adc_raw * adc_raw);
            ++count;
            prevMicros += sampleInterval;
        }
    }

    double rms = sqrt((float)currentAcc

```

```

/ (float)numSamples) * (50 / 1024.0);
rms = ((rms - 0.04) * 100);

current[4] = rms;
}

```

```

void CurrentSense6() //72w load 1
D=24/25
{
  unsigned long currentAcc = 0;
  unsigned int count = 0;
  unsigned long prevMicros = micros()
- sampleInterval ;
  while (count < numSamples)
  {
    if (micros() - prevMicros >=
sampleInterval)
    {
      int adc_raw = analogRead(6) -
adc_zero;
      currentAcc += (unsigned
long) (adc_raw * adc_raw);
      ++count;
      prevMicros += sampleInterval;
    }
  }

  double rms = sqrt((float)currentAcc
/ (float)numSamples) * (50 / 1024.0);
rms = ((rms - 0.04) * 100);

  current[5] = rms;
}

```

```

void CurrentSense7() //72w load 2 =
D22/23
{
  unsigned long currentAcc = 0;
  unsigned int count = 0;
  unsigned long prevMicros = micros()
- sampleInterval ;
  while (count < numSamples)
  {
    if (micros() - prevMicros >=

```

```

sampleInterval)
  {
    int adc_raw = analogRead(7) -
adc_zero;
    currentAcc += (unsigned
long) (adc_raw * adc_raw);
    ++count;
    prevMicros += sampleInterval;
  }
}

```

```

double rms = sqrt((float)currentAcc
/ (float)numSamples) * (50 / 1024.0);
rms = ((rms - 0.04) * 100);

current[6] = rms;
}

```

```

void CurrentSense8() //current
into/from transformer (L2 from
microinverter essentially)
{
  unsigned long currentAcc = 0;
  unsigned int count = 0;
  unsigned long prevMicros = micros()
- sampleInterval ;
  while (count < numSamples)
  {
    if (micros() - prevMicros >=
sampleInterval)
    {
      int adc_raw = analogRead(8) -
adc_zero;
      currentAcc += (unsigned
long) (adc_raw * adc_raw);
      ++count;
      prevMicros += sampleInterval;
    }
  }

  double rms = (sqrt((float)currentAcc
/ (float)numSamples) * (50 / 1024.0));
rms = (((rms - 0.015) * 100) * 2);
current[7] = rms;
}

```

Appendix I. SolarEdge Single Phase Inverter SE3000A-US

The SolarEdge Single Phase Inverter SE3000A-US is a central inverter sold for the US grid system that can handle a solar PV system of 3kw. This inverter is designed to work with power optimizers (DC/DC converters on solar strings), and has anti-islanding protection in accordance with UL1741 / IEEE1547 requirements. The inverter is 98% efficient and communicates to the internet through either ethernet or a SolarEdge wireless communicator. It can be mounted indoors or outdoors. The inverter is capable of a surge AC power output of 3.3kW. The nominal output voltage is 240V split phase but can range from 211-264V. The maximum DC power input is 4050W. The AC frequency tolerances are 59.3-60.5Hz.⁶²

62

SolarEdge. (2017, March 29). *SolarEdge Single Phase Inverters*. Retrieved from SolarEdge: <http://www.solaredge.com/sites/default/files/se-single-phase-us-inverter-datasheet.pdf>

Appendix J. Maximum Power Point Tracking

Maximum Power Point Tracking is when a solar optimizer will adjust the DC voltage on the panel to produce the maximum amount of power it can. An example of this is shown in the Figure above. As the day progresses, the amount of light the panel receives changes, and thus the V-I characteristics change. This moves the maximum power point around. The goal of the solar optimizer is to continuously find the maximum power point to ensure the solar system is always supplying maximum power. Since power is calculated using volts times amps, the solar optimizer will run this calculation as it shifts the DC voltage around in small increments until it finds the maximum amount of power.

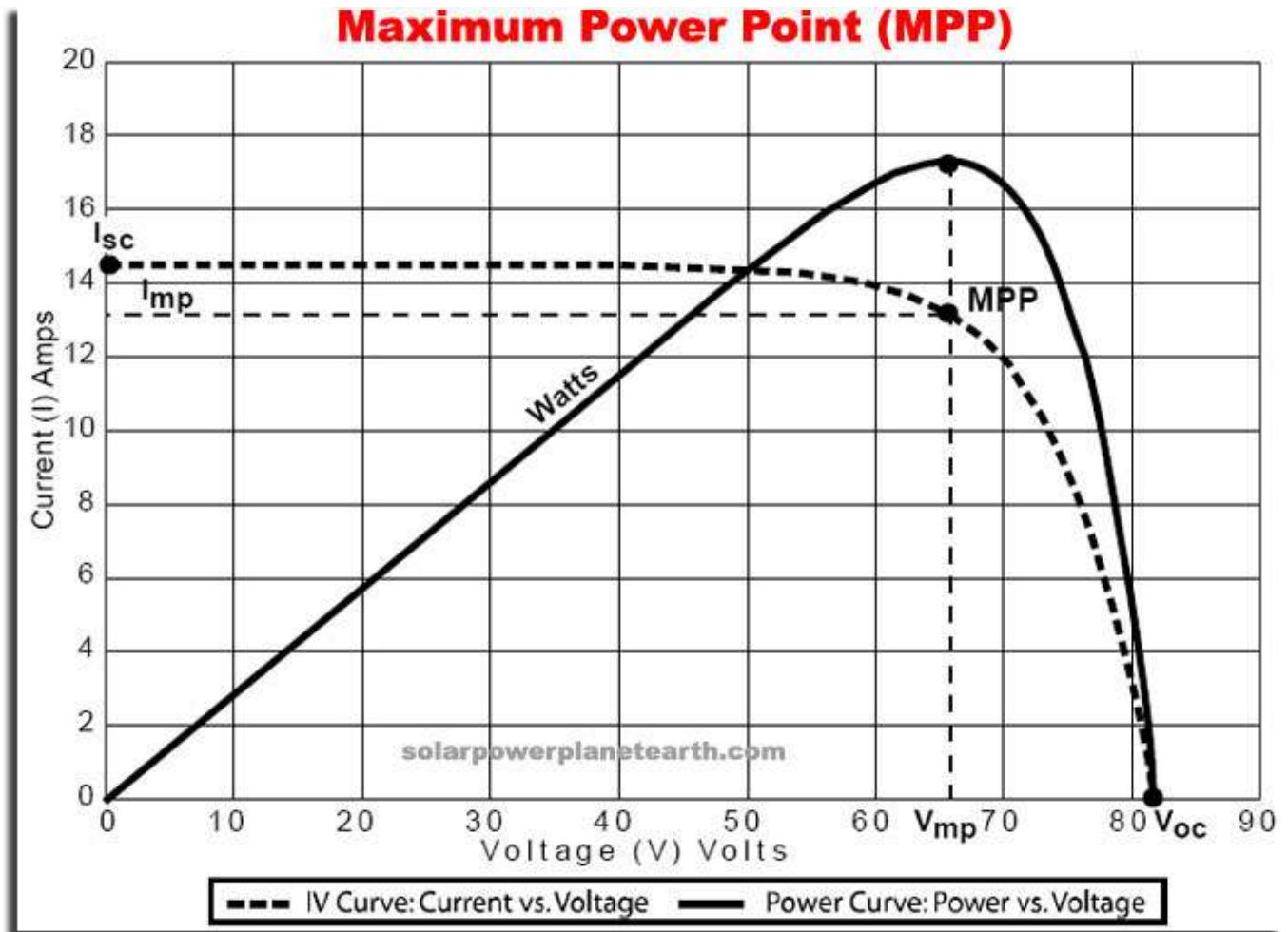

Source: Solar Power Planet Earth. (n.d.). *Solar Power Charge Controllers*. [Online image] Retrieved from Solar Power Planet Earth: <http://solarpowerplanetearth.com/solarchargecontrollers.html>