

Worcester Polytechnic Institute Digital WPI

Major Qualifying Projects (All Years)

Major Qualifying Projects

April 2008

Refinement of a Treadmill

Bryan Thomas Mancuso
Worcester Polytechnic Institute

Daniel Corrigan Murphy
Worcester Polytechnic Institute

Jacob Haronian Troiano
Worcester Polytechnic Institute

Follow this and additional works at: <https://digitalcommons.wpi.edu/mqp-all>

Repository Citation

Mancuso, B. T., Murphy, D. C., & Troiano, J. H. (2008). *Refinement of a Treadmill*. Retrieved from <https://digitalcommons.wpi.edu/mqp-all/3315>

This Unrestricted is brought to you for free and open access by the Major Qualifying Projects at Digital WPI. It has been accepted for inclusion in Major Qualifying Projects (All Years) by an authorized administrator of Digital WPI. For more information, please contact digitalwpi@wpi.edu.

Project Number ME-ECC-A704

REFINEMENT OF A TREADMILL FOR ELDERLY USERS

A Major Qualifying Report
Submitted to the Faculty of

WORCESTER POLYTECHNIC INSTITUTE

in partial fulfillment of the requirements for the
Degree of Bachelor of Science in Mechanical Engineering

By

Bryan Mancuso

Daniel Murphy

Jacob Troiano

April 24, 2008

Approved:

Professor Eben C. Cobb, Advisor

Keywords:

1. Treadmill
2. Elderly
3. Exercise

Abstract

This project continued previous work modifying a treadmill to better fit the needs of elderly users. The project modified four aspects of a stock treadmill. The first modification was the addition of a handrail system for increased safety. The second was a speed reduction mechanism to allow for finer control. The third was a user interface tailored to the difficulties that present with aging. The fourth was a new walking surface to absorb more impact than the original surface.

Executive Summary

The objective of this project was to continue work on modifying a treadmill to better fit the needs of elderly users. Previous work on this subject includes an MQP where the group identified these needs and modified a stock treadmill to better meet them. Based on a survey of local senior citizens, they determined that a treadmill would be the best machine to modify. They attempted to soften the impact force users experienced. They also constructed handrails for added support and safety. Another modification that they made was altering the motor control circuit to allow it to run at lower speeds. The final modification was a new user interface tailored to the specific needs of elderly users. After constructing a working prototype they performed clinical tests, asking elderly persons to use the treadmill and comment on its features. Based on these results, we modified a new treadmill to address users concerns with the original prototype.

Unfortunately, the prototype from the previous project was improperly stored after the completion of the project. We therefore had to start anew with a different treadmill. This was not a major setback however, since our final designs were significantly different from the first prototype. Our design focused on the four major objectives but accomplished them in different ways.

The previous project attempted to soften the impact force users experienced by attaching a soft material to the treadmill belt. They were unable to attach this material in a way that withstood the constant flexure to which the belt is subject during operation. Our solution to this problem was to replace the walking surface beneath the treadmill belt. The original walking surface did very little to absorb impact force. It was a piece of particle board screwed to the treadmill frame. To lessen the damage to users' knees, and other soft joints, we replaced this surface with soft foam tiles. To provide the necessary stiffness, the foam was glued to an aluminum plate, which was bolted to the treadmill frame. To ensure that the belt would slide properly against this new surface a thin sheet of smooth plastic was glued to the top of the foam.

The handrails constructed by the previous project were unnecessarily large and fairly ineffective. They consisted of metal bars supported by 2x4 and 4x4 wooden beams. This structure was very difficult to move, and it significantly increased the

footprint of the treadmill. Our solution was to mount a modified walker onto the treadmill. These modifications allowed the walker to be adjusted horizontally as well as vertically. We chose a walker because it was a device that elderly users who need support while walking would be familiar with. The small metal frame is significantly less imposing than the large wooden structure the previous group constructed. Also, the walker can be easily removed, allowing the treadmill to be folded up as originally designed. Another support mechanism the previous group added, which we did not consider necessary, was a parachute harness to be worn by users. In the clinical tests, most users found the harness to be too cumbersome to use, even those who would have significantly benefited from it.

Most stock treadmills will not operate at speeds below around 0.5 miles per hour. The previous group found this to be too fast for some elderly users. Their solution was to create a new control circuit which would allow the motor to run at slower speeds. This was not entirely successful, due to a lack of electrical knowledge. The modified circuit did not allow the treadmill to operate at speeds above 4 miles per hour. The clinical test showed that some elderly users desired higher speeds. Since we did not feel qualified to create a new control circuit we chose a mechanical solution to this problem. We attached a system of pulleys to our motor which could be engaged or disengaged by the user. When engaged, the pulleys cause a 5:1 reduction in speed, resulting in a range of speeds from 0.1 to 2 mph. When disengaged, the treadmill operates normally, with a range of 0.5 to 10 mph. When engaged, this system also gives the user finer control of the speed of the treadmill.

The user interface designed by the previous group contained four round buttons and an LCD display. The buttons were not easily distinguishable by touch. The background of the interface was a piece of clear plastic. The transparency of this surface introduced unnecessary and confusing visual cues. Also, the group was unable to output data to the display due to the modifications that they had made to the control circuit. The original user interface for our treadmill was not well suited to the needs of the elderly. The system was a single flat surface with membrane buttons that was primarily grey with highlights of white, black and red. We sought to redesign the user interface to compensate for colorblindness, blurred vision, and yellowed lenses, common problems

experienced by elderly persons. Additionally, we added large, high contrast buttons painted in three different fluorescent colors to indicate speed control, stop, and incline adjustment. The stop button is a red octagon, the speed control buttons are green arrows pointing up and down and the incline adjustment buttons are yellow arrows pointing up and down. These buttons have dramatic corners to provide significant tactile response. To improve visibility, we painted the background of the interface black. We left the control circuit unmodified so that we could use the treadmill's original LCD readouts.

Table of Contents

Abstract.....	ii
Executive Summary	iii
1. Introduction.....	1
2. Background.....	3
2.1 Previous Project	3
2.1.1 Machine Selection.....	3
2.1.2 Support System.....	3
2.1.3 Walking Surface.....	4
2.1.4 Speed Control.....	5
2.1.5 User Interface.....	5
2.2 Prototype Base	6
2.3 Handrails.....	6
2.4 User Interface.....	7
3. Methodology	8
3.1 Design Specifications.....	8
3.2 Walking Surface.....	8
3.2.1 Original Surface	8
3.2.2 Design Selection	9
3.2.3 Material Testing	10
3.3 Handrail System.....	13
3.3.1 Disk Design.....	14
3.3.2 Walker Design	16
3.3.3 Handrail Selection.....	19
3.4 Speed Reducer	20
3.4.1 Gear Design	20
3.4.2 Pulley Design.....	20
3.5 User Interface.....	21
4. Results and Analysis.....	24
4.1 Final Walking Surface	24
4.2 Final Handrail Design.....	25
4.3 Final Speed Reducer Design.....	31
4.4 Final User Interface Design	34
5. Conclusions and Recommendations	38
5.1 Walking Surface.....	38
5.2 Handrails.....	38
5.3 Speed Reducer	39
5.4 User Interface.....	40
5.5 Comparison to Previous Prototype	40
References.....	42
Appendix A.....	44

List of Figures

Figure 1: Previous Handrail System	3
Figure 2: Parachute Harness	4
Figure 3: Previous User Interface	5
Figure 4: Crosswalk 325 (from users' manual)	6
Figure 5: ANSYS Analysis	13
Figure 6: Initial Locked Position	15
Figure 7: Unlocked Position	15
Figure 8: Unlocked, Adjusted Position	15
Figure 9: Adjusted Locked Position	15
Figure 10: Folded Cabled Four Bar Linkage Handrail	16
Figure 12: Peg Joint Concept	18
Figure 11: Guardian Easy Care Folding Walker	18
Figure 13: Initial Pulley Design	21
Figure 14: Final Walking Surface	25
Figure 15: Initial Walker to Treadmill Joint Concept	26
Figure 16: Final Walker to Treadmill Joint Concept	27
Figure 17: 2-Degree of Freedom Joint to Connect Telescoping Tubes to Walker Arms .	30
Figure 18: Telescoping Tubes Attached to the Walker Arms	31
Figure 19: Initial Collar Design	32
Figure 20: Final Collar Design	32
Figure 21: Final Speed Reducer	33
Figure 22: Original User Interface	35
Figure 23: New User Interface	37

List of Tables

Table 1: Handrail Design Matrix	19
Table 2: Lengths of the Telescoping Tubes for Given Widths	29

1. Introduction

The global elderly population is on the rise. In industrialized countries, 15% of the population is 65 years old or older. This number is expected to rise to 25% by 2025 [Barratt]. As this age group grows, new industries form to address their specific needs. One of these is the need to stay active and healthy. The increase in average life expectancy has led to an increased interest in staying healthy despite age-related inconveniences. Although fewer people are experiencing major age-related inconveniences as they grow older, due to medical advances, some of the more minor effects of age are still very common.

Currently, most exercise equipment is designed for users who are in good general health. There are no exercise machines that market specifically to elderly users. There is some equipment designed for disabled users and physical therapy that will meet some of an elderly user's needs, but there are currently no commercially available devices that meet all of the needs of elderly users.

In an attempt to create an exercise machine that satisfies all of the needs of elderly users, we modified a stock treadmill based on data collected from a previous MQP. We replaced the walking surface underneath the belt with a softer material, to lessen the stress on users' legs. We also mounted a walker to the treadmill for users who require additional support while they are walking. Another modification that we made was the addition of a speed reducer to allow the treadmill to run at speeds below its original range. Finally, we replaced the user interface with one that was tailored to the specific visual and tactile impairments that typically occur with age.

While our final design is not ready to be mass-produced, it does meet elderly users' needs better than the stock treadmill we started with did. Some elements of it are relatively close to being commercially viable. The new walking surface we installed is significantly better at absorbing impact than the original surface. With some additional refinement the walker we mounted on the treadmill could be sold as an after-market add-on for any treadmill. The user interface still needs a significant amount of work to become what we originally designed it to be. The mechanical speed reducer, while it was the best solution we could develop, is not an optimal solution. It would be significantly simpler to have someone with knowledge of electronics design a new control circuit that

would allow the treadmill motor to run at lower speeds than those permitted by the original circuitry.

2. Background

2.1 Previous Project

The previous Major Qualifying Project on this subject (Design, Analysis and Testing of a Treadmill for Older Adults) built a prototype treadmill to fit the perceived needs of elderly users. Once the prototype was completed, the group conducted clinical tests to determine how well it met these needs.

2.1.1 Machine Selection

The group chose a treadmill as the exercise machine they would modify based on a survey of 121 local senior citizens. The majority of individuals surveyed said that they exercised to improve their cardiovascular health. Also, when asked which area of their bodies limited their exercise the most common answers included knees, ankles and feet. Based on these responses, and also considering other factors such as feasibility of modification, the group examined three different exercise machines. Ultimately, they determined that out of a treadmill, an elliptical machine and a stationary bike a treadmill would be the most suitable for their project.

2.1.2 Support System

The first modification the previous group made to their treadmill was the addition of a support system. This system included handrails along the sides of the treadmill and a parachute harness suspended above the treadmill.

The handrails they made were mounted on a wooded support structure made of 2x4 and 4x4 beams (Figure 1). In total, the structure held four rails, two at a fixed height and two whose heights could be adjusted. The railings were mounted outside the envelope of the treadmill and the adjustable set extended inwards for easier gripping. Where the height of the railings

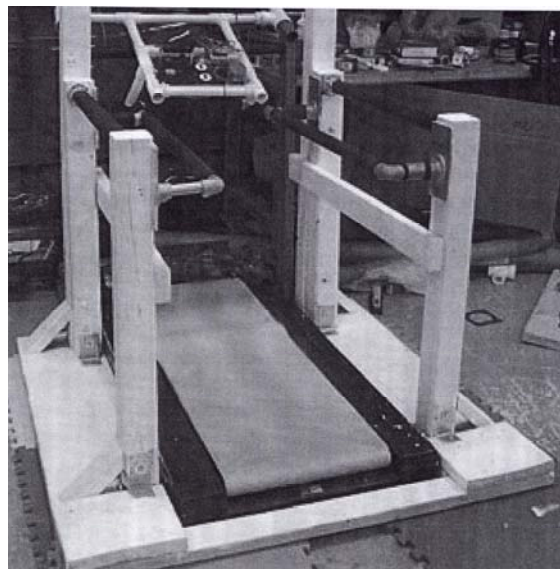

Figure 1: Previous Handrail System

was adjustable in 1 inch increments, the widths of the railings were fixed. These railings spanned the full length of the treadmill. Given the wooden structure of the railings as well as the base they were positioned on, this system added a considerable amount of weight and increased the size of the treadmill's footprint significantly.

The prior group had also created a separate safety system to provide support for users of the treadmill. This system consisted of a parachute harness suspended from pipes attached to a more 4x4 beams (Figure 2). The harness was height-adjustable based on the straps that connected it to the pipes and frame that was built for it. The construction was made from more wooden 2x4 and 4x4 beams, and steel pipes with flanges. As with the railing system the harness frame added a considerable amount of weight and increased the size of the treadmill significantly. The clinical trials performed by the group yielded both positive and negative feedback regarding these two systems. The constructive criticism

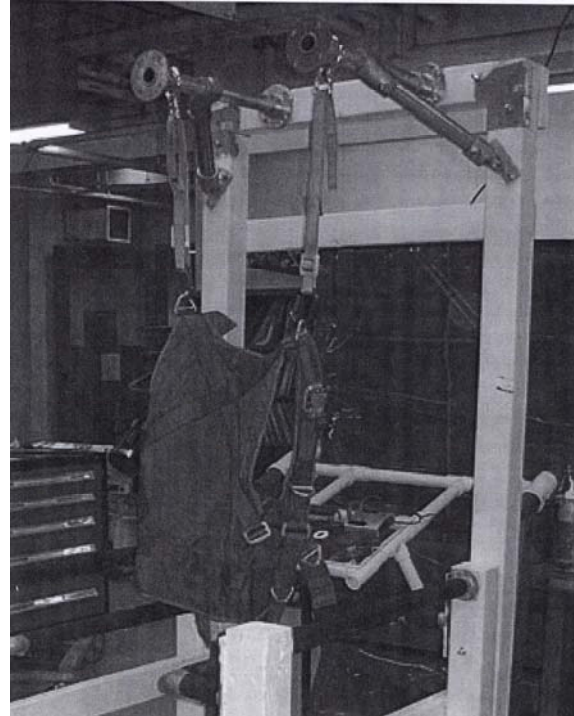

Figure 2: Parachute Harness

stemmed from the lack of adjustability in the handrail system, the size of the treadmill, and the harness. The treadmill was too large according to some of the respondents and they do not want such a large device, especially when it cannot be stored or moved easily. The inclusion of the harness apparatus was appreciated by the respondents; however few of them actually used it. The task of getting into and out of it was too daunting. Also, the harness was considered by those who did use it extremely cumbersome and uncomfortable.

2.1.3 Walking Surface

In an attempt to dampen the impact force on users' legs and joints, the previous group attached a soft material to the treadmill belt. They ultimately decided to use 0.125in thick natural gum rubber. They tried to attach it to the belt in several different

ways, including using multiple types of adhesive and stitching the two together. None of these techniques could withstand the constant flexure to which the belt was subject during normal operation. Eventually, the process of the belt wrapping around the rollers driving it caused the rubber to detach from it.

2.1.4 Speed Control

To allow for finer speed control, the previous project used a programmable controller from a VEX robotics kit to alter the signal to the treadmill's motor. This allowed users to select speeds with more specific control and it also allowed them to select lower operating speeds. Unfortunately, it did not allow the treadmill to run at speeds above 4mph. They also had difficulty using the controller to output to an LCD display.

2.1.5 User Interface

The previous project created an entirely new user interface for their treadmill (Figure 3). It consisted of three large buttons (stop, increase speed and decrease speed) mounted on a translucent plastic backing. We found that the visibility of the buttons in their own right was acceptable; however they were mounted onto a sheet of clear plastic. The ability to see through the background added an undesirable amount of confusing visual cues. Additionally, it included a passive LCD display, which was not compatible with the electronics used in our treadmill and was not sufficiently large to remain readable by those with vision impairment. Additionally, it was found that if pressure was applied only near the periphery of the buttons, the bending moment would cause the button to bind within its housing and resist or prevent motion.

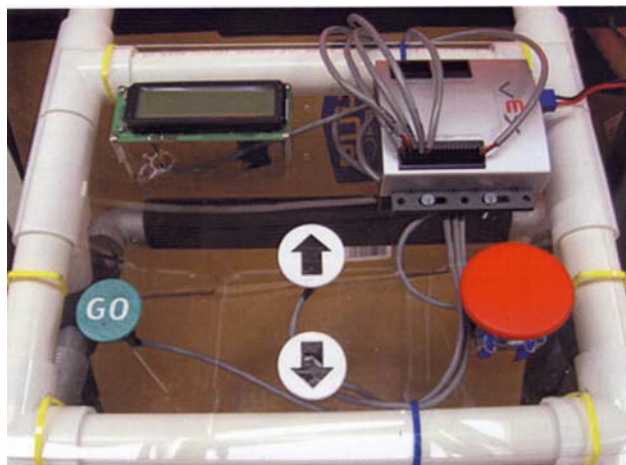

Figure 3: Previous User Interface

2.2 *Prototype Base*

A Porform Crosswalk 325 treadmill (Figure 4) served as a base device, to which we made modifications. The use of an existing model saved considerable time and resources which would have been needed to construct components which require no modification to suit the needs of the elderly.

Before modification, the treadmill was capable of varying its speed from .5 to 10 miles per hour in .1 mph increments according to user input. It was capable of adjusting the incline of the walking surface by means of motorized support legs near the rear of the surface. The walking surface

could be manually lifted to a vertical position and locked into place for storage and movement. By visual inspection, the support for the belt was determined to be a .75 inch thick sheet of particle board or some equivalent wood composite. This surface was quite rigid, and determined to be too hard for some users with mobility issues. The control system featured an automatic shutdown function. Shutdown was triggered by a plastic tab, which must be inserted into a slot on the console for the treadmill to operate. There is a string attached to this tab which the user may clip or pin to his or her clothing. In the event that the user moves too far from the console, the string pulls the tab from the console and the motor loses power.

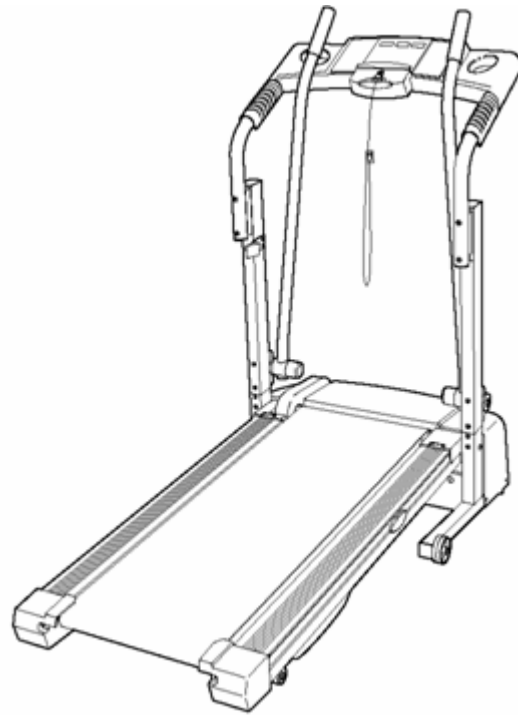

Figure 4: Crosswalk 325 (from users' manual)

2.3 *Handrails*

One unavoidable consequence of aging is a decrease in kinesthetic sensitivity, the ability to determine where parts of one's body are without looking at them. This can lead to trouble maintaining balance, increasing the likelihood of falling. Currently, most treadmills do not feature a device that a person could use to support himself when losing his balance.

One option to help prevent users from falling is installing handrails along the sides of the treadmill, which the user could grab and support himself with in the event of a fall. In some cases however, the simple presence of the handrails might not be enough. Unless a user is constantly holding onto the handrails, he must be able to react quickly enough to grab them if he senses that he is falling. Since reaction time often decreases with age, the handrails must draw attention to themselves.

A recent study at the Sunnybrook Health Sciences Centre explored ways to increase the likelihood of a person using a handrail in the event of a fall [Scovil]. They explored several different audible and visual cuing methods to draw attention to the handrail, in hopes of increasing reaction time during a fall. They found that adding flashing lights to the handrail and a recorded voice referencing it both increased the likelihood of a test subject using the handrail.

2.4 User Interface

A user interface designed for elderly users must take into account several common inconveniences that people often experience as they age. The first of these is a decrease in visual acuity. Vision problems are virtually unavoidable with age. Most people begin to notice some decrease in vision around the age of 40 [Barratt]. To account for this, any text on the interface should be large and should stand out from the background of the interface. Also, the controls should be large and easy to distinguish from each other. Large controls would also be helpful for users with decreased fine motor skills.

3. Methodology

3.1 Design Specifications

- Walking Surface
 - Must be able to support a person weighing a maximum of 250 pounds
 - Must have a coefficient of friction of at least 0.5 between the tread surface and an average shoe
 - Must not have accelerations that exceed +0.1g (3.2 ft/sec), the common value for gentle acceleration of an automobile

- Rail System
 - Each handrail must be able to withstand a vertical force of 200 pounds
 - Each handrail must be able to withstand a force of 150 pounds in any direction
 - The height of each rail must be easily adjustable between 33 and 39 inches
 - The distance between the handrails must be easily adjustable between 24 and 30 inches

- User Interface
 - Must have at least one manual and one automatic emergency stop system
 - Each emergency stop system must stop the belt within 2 seconds at maximum speed
 - Must be clear and concise to older adults
 - Buttons at least one inch in diameter
 - Buttons easily recognizable by touch
 - Easily distinguishable colors
 - Easy to read text
 - Speed must adjust from 0 to 5 mph (in increments of 0.1 mph or less)

- Additional Specifications
 - Modifications must increase the weight of the treadmill by no more than 20 percent.
 - Device must cost less than \$1000 to construct
 - Device must plug into standard 120V outlet
 - Device must have no sharp surfaces
 - Device must assemble with household tools
 - Device must collapse to fit through standard 28 in wide door without using tools

3.2 Walking Surface

3.2.1 Original Surface

The walking surface of a treadmill consists of the thin moving belt and a rigid plate held between the two surfaces of that belt in order to provide support when the transverse load of footfalls are applied. The original and unmodified treadmill used a

sheet of 0.75 inch pressed particle board as a support plate. This was attached to the frame of the treadmill at four points with wood screws placed near the four corners of the sheet. While resting on the rails in a lowered position, the plate received vertical support from small metal risers at the mounting points and from two rubber pads placed under the longest edge of the surface midway between the hard mounting points. According to the manual provided with the treadmill, the design intent behind this flexible multi-point mounting system was to decrease the overall stiffness of the plate by providing less support than that provided by direct attachment to two solid rails. In actual practice, the thickness and stiffness of the particle board surface were more than adequate to eliminate all discernable deflection from the system. Users were unable to distinguish the difference in stiffness when additional aluminum supports were inserted between the sheet and the rails, in order to eliminate the compliant effect of the rubber supports. We concluded that modifications would be necessary to achieve a noticeably compliant walking surface capable of decreasing the impact forces associated with walking and running. Additionally, the bottom face of the particle board sheet held two outwardly angled metal brackets. These were oriented such that the belt would slide over them continuously when the system was active. This had the effect of automatically maintaining alignment of belt by creating a restoring force in the event that the belt traveled away from a centered position on its rollers.

3.2.2 Design Selection

From review of the efforts made by the previous MQP group, we knew that attempting to provide damping by applying a soft layer to the outside of the walking belt would be problematic. The continual cyclic straining caused by travel over a small (1-2 inch diameter) roller was so severe that neither chemical nor mechanical fastening methods were sufficient to hold the softening layer in place during any long-term operation. One option discussed was to place a similar softening layer on the inside of the belt. This concept was rejected for two reasons: proper friction interface between the new material and the rollers would be difficult to determine and maintain and that the installation of that layer would require the removal of the existing belt from its rollers and possibly its replacement by a new larger belt. Repair recommendations from the manufacturer and exercise replacement part vendors strongly cautioned against

operations involving the removal and/or replacement of belts, as it is difficult to return the belt to a true and straight state of alignment on the rollers particularly if a non-standard belt size is used.

The group therefore decided to replace the particle board walking surface with a more compliant material. Rubber and foam materials designed to reduce impact during exercise were a logical starting point for consideration. A number of manufacturers produce similar rubber materials formed by pressing ground tire rubber in sheets and binding the particles together with a polyurethane adhesive. These materials are weatherproof and designed to retain a high coefficient of friction when wet (one manufacturer claims a reduction from .67 to .64 under ASTM C1028-84 testing conditions) [Dinoflex]. Also these rubber materials are primarily designed to increase safety in playground situations by limiting the peak force experienced in the event of a fall. These are assessed under ASTM 1292-99, which defines testing procedures designed to estimate risk of head trauma in falls from various heights as quantified by the HIC (Head Injury Criteria) score. These hard rubber tiles measure as approximately 70 degrees on the Shore A scale [Dinoflex] and an density of (numbers). The other materials considered were soft foam tiles. These are primarily sold for use in playrooms for young children. Their outer surface is non porous, and will become slick if wet. These materials are not generally designed or tested for the impact due to falls from significant heights. The primary component of the foam used in these mats is Ethylene-vinyl acetate. The use of this material particularly attracted our attention because it is regularly used, in the form of dense foam, as a shock absorbing material in running shoes. These tiles measure 35 degrees (some variation due to density) on the Shore A scale and have a density of (numbers) [Cha Yau Sponge]. Both options appeared to be sufficiently applicable to our problem to warrant actual testing with samples from the manufacturer.

3.2.3 Material Testing

As anticipated, we immediately determined from the ability of both materials to deflect significantly in our bare hands that neither material was sufficiently stiff to weight of a grown person if used to span the two feet between the metal support rails of the treadmill. In order to eliminate this flaw, we elected to support one of the two with a metal plate and create a composite support surface. In order to maintain proper motion of

the belt, it was necessary to ensure that the composite surface is not more than .125” thicker than the original surface. This design consideration seriously limited our choices of material for both the rigid portion and the compliant portion. Because impact reduction was the primary concern the selection of the dampening material would govern remaining aspects of the design. We had at our disposal for testing a .5 inch thick compressed rubber panel, a .5 inch thick EVA foam panel and a .25 inch thick EVA foam panel. We asked a small set of volunteers to express their qualitative assessment of the impact felt upon striking each sample material. They were instructed to hold their knees straight and drop 6 inches from a small platform such that the heel of one foot firmly impacted the test material while barefoot. They were asked to repeat this test on a bare concrete floor, a hardwood floor and on each surface while placed on the concrete floor. The first two were used as reference points for the volunteers to describe their assessment of the test samples. Each was able to feel a marked difference in sensation of impact between the concrete and the hardwood. Most volunteers expressed surprise that there was no perceivable difference between the hardwood and the compressed rubber on concrete. They noted significant improvement with the EVA foam, particularly with the .5 inch sheet. One commented that the difference in softness between the .25 and .5 inch EVA was more than the factor of two that their physical dimensions would suggest. The disparity is most likely due to the tendency of elastic materials in compression to “bottom out” when strained significantly and exhibit stiffness significantly greater than that encountered in their normal operating range. The results of the test were clear, to the degree that some volunteers specifically recommended the use of the .5 inch EVA when the goal of the testing was explained.

The surface of the EVA was noticeably less smooth than the particle board surface, and it was therefore necessary to apply an additional layer of material between the foam and the belt in order to reduce friction. Preliminary experiments performed with sheets of Plexiglas indicated that a smooth plastic would provide a similar coefficient of friction for the belt. However, we also found that those same properties severely interfered with the ability of the plastic to remain stationary on the foam. Adhesives proved ineffective at remedying the situation, due to the large deflections causing shear at the adhesive interface. A mechanical connection was necessary to

ensure that slipping would not occur. Catalogs of common stock plastic sheets did not contain any materials with sufficiently different surface properties on their two faces. The suggestion of a home improvement store employee, we examined plastic covers for fluorescent lighting fixtures. These were sold pre-cut to approximately the appropriate dimensions for the support plate and most have two dramatically different surfaces. Samples were qualitatively examined for size, flexibility and smoothness. Only four materials were sufficiently thin to be used in the treadmill. Two materials with very regular pattern of square texturing appeared to provide excellent resistance to slipping, but were inflexible; however they were formed of polystyrene which is brittle and prone to fatigue. The two other sheets were made of a significantly more flexible and break resistant material acrylic material, both produced by the Plaskolite Company. Both had irregular texture pattern; the “cracked ice” option provided an excellent interface and was ultimately selected for use in the construction of the walking surface.

The selection of the shock absorbing portions of the walking surface essentially defined the thickness of the rigid plate at .25 inches. We were unable to locate any appropriate analytic deflection or stress calculation methods for a simply supported plate subjected to normal point or pressure loading. Our research into the forces caused during human locomotion indicated that the peak load generated is equal to at most three times the individual’s body weight. This load is generated during full capacity sprinting which is not particularly easy to achieve on a treadmill however, for the sake of safety we used this the most conservative value. The recommended maximum weight for individuals using the unmodified treadmill is 250 lbs. In order to accommodate these individuals the walking surface should be able to support loads of 750 lbs. Above this we applied a factor of safety of 3 for simulation of a simply supported plate of the appropriate dimensions. The use of a simply supported model further increases the factor of safety, because the plate is securely bolted to the rails and thus receives reaction moments from the support rails. We can draw a general comparison therefore between the simulation and the analytic solution to a simply supported beam and between the actual plate, as installed and the analytic solution to the deflection of beam having two fixed supports in bending. The beam results indicate that the fixed system will deflect 75% less than the simply supported. In actual fact the idealized fixed support does not apply well to this

situation, because the rails are not perfectly rigid. This inaccuracy and the difference in geometries make it difficult to determine the exact safety factor introduced by modeling in this fashion how ever it is definitely greater than one, which is all that is required to maintain the desired safety of the system.

The goal of the simulation process was to design a rigid plate that would not deflect more than .25 inches and would not experience any localized stresses higher than the yield strength of the material. All testing was performed in ANSYS with a new mesh generated for each unique plate geometry. The first design tested was a .25 inch steel plate. This was estimated to be the strongest combination of materials and geometries possible given our materials. Had it not been successful, the walking surface would have required a complete redesign to accommodate thicker supporting material. Fortunately, the solid steel proved to be more than adequate for the task. Next the same geometry was analyzed using material properties for aluminum. This sample barely passed our test criteria (deflection was ~.22 inches). In an attempt to reduce weight steel plates with patterns lightening holes were

tested (Figure 5) however, once approximately 60% of the material had been removed (necessary to approach the weight savings of aluminum) stress concentrations due to hole geometry caused localized stresses greater than the yield strength of the steel. The logical selection was the aluminum plate as it met the design requirements with the least possible weight.

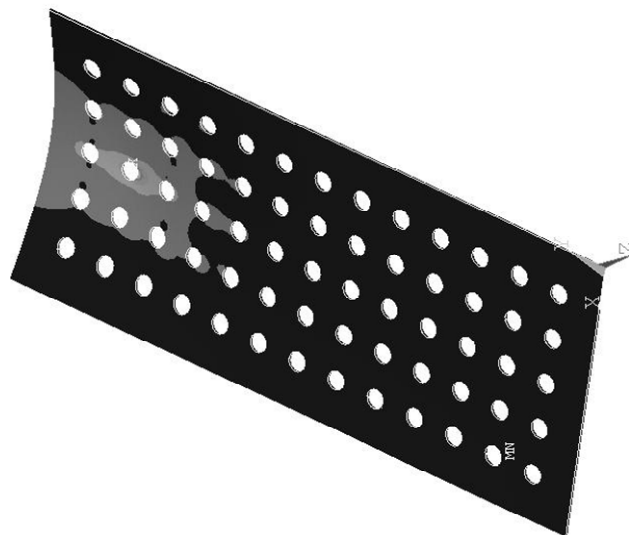

Figure 5: ANSYS Analysis

3.3 Handrail System

Based on the work done by the prior group working on the treadmill for elderly persons concept, we made the decision to redesign the handrail system and to abandon the idea of having the harness altogether. The decision to not include the harness in our

design was made because the reception of the harness received from the persons who tested the treadmill was lackluster. They all seemed to like the idea of the inclusion of one, but no one actually desired to use it. Since this feature was not being utilized, we decided that it would be better if we focused on the other aspects of the treadmill design. Excluding the harness structure allows us to capitalize on another suggestion made by the group who tested the old design, to make the treadmill more compact and moveable. The base treadmill we started with, the ProForm CrossWalk 325, was designed so the walking surface pivoted upwards to the user interface for compact storage (smaller footprint) and so it could be moved more easily. We decided to design our modifications such that that functionality remained intact.

The design of the CrossWalk 325 made it necessary because it does not have any railings on it for any span of its length. It only has two small hand grips between the uprights that support the user interface, and the interface itself. In order to grab these the user's arms need to be extended out in front of the body, rather than pointing in a more downward direction to support one's weight. The previous group's treadmill suffered from the same problem and they built their own railing system that existed outside the original treadmill's envelope, making it unable to fold, let alone taking up much more floor space. Their railings were not width adjustable and had limited height adjustment built in. The users in their test group commented on the lack of adjustment in the handrail system and the bulk it added to the overall design of the treadmill. In order to be consistent with the design decision to maintain the ability for the treadmill to store more compactly, we needed to redesign the railings to both be more adjustable and more compact.

3.3.1 Disk Design

The first handrail design developed allows the user to adjust the horizontal distance between the rails by rotating the top section of each rail. Attached to each of the supports for the rail is a disk with holes cut in it. A disk with matching protrusions that will fit into these holes is attached to either end of the rail. These two disks are held together with a spring positioned inside of the support (Figure 6). When a user wants to adjust the rail, he or she pulls against the spring, separating the two disks (Figure 7),

rotates the rail to the desired angle (Figure 8), and pushes it back into its locked position at the new angle (Figure 9).

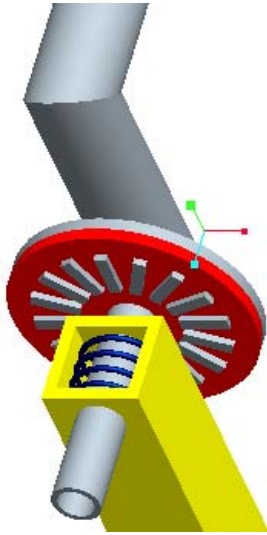

Figure 6: Initial Locked Position

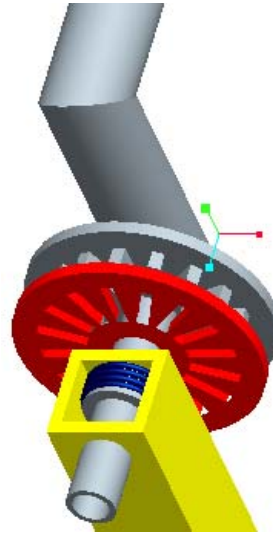

Figure 7: Unlocked Position

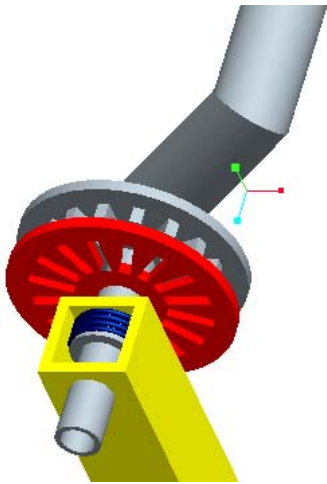

Figure 8: Unlocked, Adjusted Position

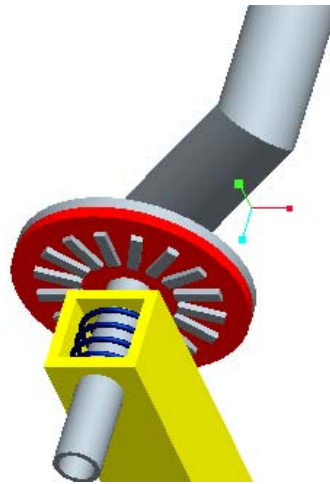

Figure 9: Adjusted Locked Position

One of the advantages of this design is that it is a very simple mechanism. There are no complex moving parts that could break if it is used improperly. It also requires very little fine motor skill. Some accuracy is required in aligning the protrusions with the holes, but this can be minimized through the shape of the protrusions.

One of the disadvantages of this design is that, depending on how much force is required of the spring to keep the disks together, it may be too hard for some users to adjust without assistance. Another disadvantage is that the disks take up a considerable

amount of space, and may interfere with the user. Further testing may prove that full disks are not necessary to provide adequate support, but this is currently unknown. In addition, a user cannot adjust the distance between the handrails without also changing the height of the rails. Finally, the two handrails adjust independently. A user may have difficulty adjusting them both to the same position.

3.3.2 Walker Design

The Crosswalk 325 treadmill is fitted with an upper body exercise mechanism, which consists of two bars attached to the base of the treadmill within the vertical supports of the device. These bars rotate about an axis parallel to that of the belt rollers. These bars inspired the second iteration of the design for a support mechanism for the user. The intent is to use bars similar to these exercise bars to hold a support bar or frame above the walking surface of the treadmill. This proposed mechanism uses a parallelogram based four bar linkage (Figure 10) to ensure that hand grips are held parallel to the walking surface at a number of horizontal and vertical positions. One link of this system would not be a solid bar; rather it would be a cable. An appropriately sized cable will provide a sufficient magnitude of force to prevent the handrail mechanism from pitching to a non-level position.

The long link and the cable should be able to adjust to a number of different lengths and the angle at which they rest should be variable. Changes in angle and position will allow the handrail to be placed at any reasonable height and distance along the length of the belt. Care will be taken to ensure that the link and the cable can be consistently adjusted to be the same length as each other. Failure to do so would result in the walker frame resting at a non-zero angle relative to the ground. To accomplish this task without an overly elaborate and expensive mechanism, it may be necessary to allow only a finite number of lengths.

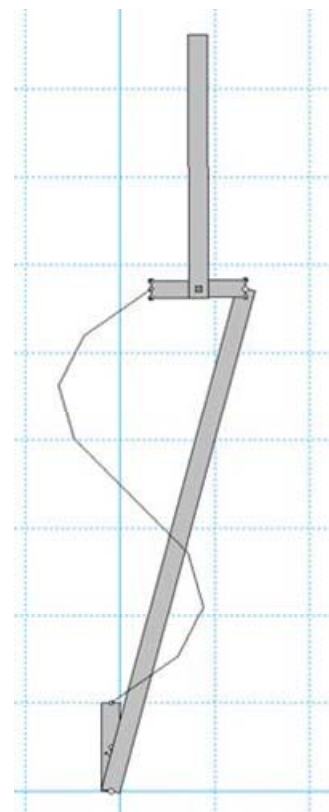

Figure 10: Folded Cabled Four Bar Linkage Handrail

The advantage of the cable is that when the mechanism is stowed, the walker mechanism can be easily rotated to a vertical position. The stowed position of this proposed linkage is very compact and would be able to lay flat on the belt in the upright and locked position with no problem. This mechanism will allow the user to be supported on either side without the need to construct a very large and heavy railing system.

In order to adjust the width of this device, a similar mechanism to the one proposed in the last design would need to be implemented. Such a system would come with the same drawbacks as the last design had and as such detracts from the feasibility of this design. Additionally, we foresee a risk with having a cable as a link in this mechanism. A potentially dangerous situation could arise if the user were to walk faster than the treadmill was going and take tension off the cable. The support the handrails would offer could be compromised and the user could get injured.

In researching other options for handrail systems, we were looking at how walkers were made and we realized that there was no sense in “reinventing the wheel” and we decided to evaluate using a commercial walker for the handrail system of our treadmill. Since it is known that the walkers adhere to safety codes and certifications, they will definitely be able to support and fit our target demographic for the treadmill. We located a walker on the classifieds website Craigslist.com in the area and purchased it for use in this project. The walker is a standard folding walker with wheels on the front two legs and one-inch height adjustment steps on all four legs. In order to make the walker safe for use on the treadmill, we needed to find a way to mount the walker to the walking surface. If the walker was not secured, the users run the risk of having the walker slip off the side of the treadmill or having difficulty reaching the user interface because the walker is capable of moving down the treadmill.

We had to now find a way to make the walker width adjustable, mount securely to the treadmill, and to not hinder the treadmill when it is in the upright and locked position. The first idea for mounting the walker was to place two or four pegs with tapered ends to the surface of the treadmill and placing the walker onto them as shown in Figure 11. The legs of the walker are hollow tubes capped at the ends, and could easily be positioned onto a peg if the caps and wheels are removed. This allows the arms of the walker to pivot as the width of the grips is increased and decreased. The problem with the pegs is that they allow too many degrees of freedom for the walker. Ideally the walker should have only one degree of freedom, pivoting about an axis parallel to the long edge of the walking surface. Also, pivoting the tubes of the legs on these pins could potentially damage the tubes over time and they could fail. It was decided that a more robust joint would have to be created for the walker.

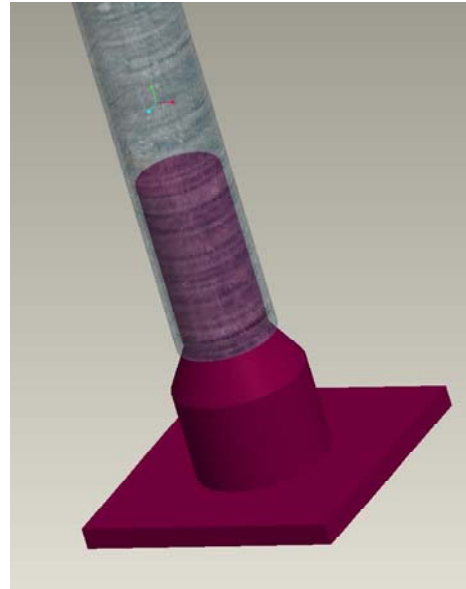

Figure 11: Peg Joint Concept

To adjust the width of the walker, the first idea was to remove the middle section of the walker support and insert a telescoping tube in its place. The original walker (Figure 12) had locks that held the arms 90 degrees from the middle support of the device. The plan was to keep that mechanism intact and add the telescoping tube to span between those two sections. While evaluating that



Figure 12: Guardian Easy Care Folding Walker

design, it was realized that the middle support would have to bend significantly when the arms were pivoting about the joints discussed in the last paragraph to affect the width of the grips. The telescoping tubing would have to either comply with the bending or joints

would have to be added to allow that to bend. It would not be good engineering practice to rely on a metal to comply with a bending force, so we looked at adding joints in the middle support area of the walker. Several problems arose with this approach. The joints we investigated using typically added too much length to the middle section leaving little to no room for the telescoping section. More problematically, adding joints also made the whole system a parallelogram with joints in all four corners so the walker would just fall to one side rather than standing upright and maintaining symmetry (angle between ground and arm) between the sides. It became clear that we would need to redesign the means for holding the arms together as well as how to keep the arms 90 degrees from that middle section.

3.3.3 Handrail Selection

	Ease of Adjustment		Likelihood of Use	Ability to Fold	Weighted Total
	Vertical	Horizontal			
Weight	40	30	20	10	
Disk	5	5	5	2	470
Walker	7	8	7	8	740

Table 1: Handrail Design Matrix

The two handrail designs were compared using a design matrix. Four criteria were chosen and given weights based on their importance. Then, each design was ranked on a scale of one to ten (ten being the best) based on how well it met each criterion. It should be noted that the most important specification for the handrail system, that it be able to support the user's weight, was intentionally excluded from this matrix. Before comparing the designs, the group determined that each of the designs could provide adequate support using standard materials.

The first criterion in the matrix was the ease with which a user could adjust the height of the rails. The disk design requires a user to adjust each of the four vertical supports separately. The walker design only requires the user to adjust two pieces, the support cable and the long link. Also, the disk design would provide a limited number of heights, whereas the walker design allows for infinite adjustability.

The second criterion was the ease with which a user could adjust the horizontal distance between the two rails. The disk design requires a user to adjust each of the two rails separately. In the walker design, the two sides are connected, so there is only one

thing that the user needs to adjust. Also, as with the first criterion, the disk design offers limited adjustability and the walker design offers infinite adjustability.

The third criterion was how likely a person is to use the rails. The walker design was given a slightly better score than the disk design. This was because the walker design has a form that people, particularly the elderly, are familiar with, and people are more likely to use something if it is familiar to them.

The final criterion was how easily the rail system folded up for storage. The disk design would require a significant amount of effort to be condensed into a size suitable for storage. The walker design can be folded up with the treadmill, and only cause a minor increase in its folded size.

3.4 Speed Reducer

To allow users to reduce the speed of the treadmill to less than 0.5mph, and to provide finer control at low speeds we added a mechanical speed reducer to the motor. We chose to do this mechanically, since the previous project's efforts to accomplish this electronically were not entirely successful.

3.4.1 Gear Design

The first design we considered was a chain and sprocket system. This worked by driving two gears off the motor, one for high speed and one for low speed. The desired gear would be meshed into a chain that ran to a shaft driving the belt that lead to the roller. The user could pivot the link to which the two gears were connected, simultaneously engaging the desired gear and disengaging the other gear. This design was quickly abandoned when research showed that it would not be practical at the speeds we would require.

3.4.2 Pulley Design

The second design we considered was a series of belts and pulleys (Figure 13). To operate at high speed, the output shaft of the motor would be connected directly to the shaft driving the belt to the roller. To operate at low speed, these two shafts would be uncoupled, and the other two shafts would be connected. In this configuration, two sets of pulleys, each in a 4 to 9 ratio, would reduce the speed of the motor output before it reached the roller.

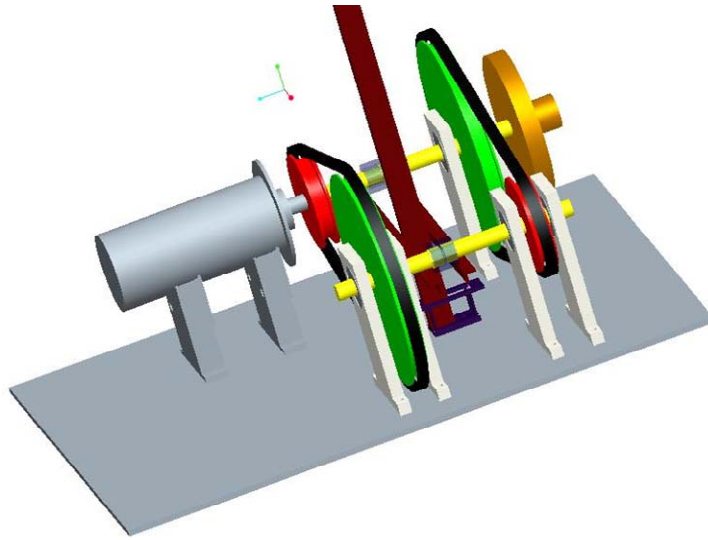

Figure 13: Initial Pulley Design

3.5 User Interface

To ensure that the redesigned user interface would be very easy to read, we set certain basic design parameters:

- All symbols must be large
- All symbols must be identifiable by shape and position
- Accessibility of the “stop” button was of primary importance, for safety
- All symbols should be differentiated from their background by the largest change in brightness possible and should not rely upon differences in color
- Surfaces should not be prone to glare or specular (mirror-like) reflection
- Buttons must be identifiable by touch through a difference in either texture or elevation relative to the background surface

To satisfy these design requirements, we selected a sheet of Plexiglas with a matte finish black applied to its outer surface. The selection of the matte finish and its application to the outer surface were vital to ensure that the surface would not create any unwanted reflections and glare. The Plexiglas was kept unpainted until construction of the user interface was complete to allow for easy inspection of the underlying electronic components. Black was selected as the background color in order to provide a high level of contrast for the brightly colored symbols.

To control the speed and incline of the treadmill arrows approximately 2.75 inches in length were cut from a sheet of machinists wax and filed to remove sharp edges. The speed buttons were painted green and the incline buttons yellow. It should be noted that certain forms of color blindness would interfere with ones ability to distinguish between these two; however the placement of each pair of arrows at opposite ends of the interface with the stop button in between eliminated the possibility of the two being easily mistaken for one another. The stop button was cut to the shape of a regular octagon 6 inches in diameter from the same machinists wax as the arrows. It was painted bright orange. It should be noted that the paints applied to all five buttons relied upon fluorescent to achieve maximum brightness. Traditional dyes and pigments are only able to remove wavelengths from the light that strikes them and create colors by reflecting a narrow band of frequencies. In contrast in a fluorescent dye, any photon of equal or greater energy than the energy level to be emitted will be absorbed and re-emitted at that target frequency. These dyes are therefore able to achieve unparalleled perceived brightness by reducing non-visible high-energy light to a single highly visible frequency. By this process we are able to increase the contrast ratio between the background and the buttons to beyond the capability of simple black and white.

The button shapes cut from the machinist wax were designed to function as covers form standard push button. In order to prevent the issue of binding encountered in the buttons on the previous MQP, each cover was attached to multiple buttons such that loads would not reduce to a simple case of bending. Each arrow was supported by two buttons along their length while the larger stop button was supported by three buttons arranged in a triangular pattern. Each set of buttons corresponding to a single button cover was wired in parallel, such that only one button was required to be depressed to the point of activation in order for the circuit to be closed.

In order to prepare the circuitry of the treadmill control system it was necessary to remove the existing button mechanisms, which were soldered directly to the circuit board in the interface console, and to reposition that circuit board to accommodate the slightly smaller space created by the Plexiglas sheet. With the buttons removed, connection wires were soldered into their place for later connection the new interface panel.

The Plexiglas sheet was cut and sanded to fit into the socket used to position the original user interface. Sets of holes to accommodate and position the push buttons were marked and drilled. The wires were threaded through the positioning holes and the buttons affixed to the Plexiglas with epoxy. The last action prior to painting was to solder the interface panel to the circuit board while it was still possible to take advantage of the transparent Plexiglas. To apply paint, the buttons were masked with tape, to ensure that their surfaces would later accept adhesives properly. The panel was painted black until completely opaque and non-reflective. Next the button covers, which had been painted separately were affixed to their associated buttons with epoxy. The completed user interface panel was attached to the interface console of the treadmill with hot glue. The only portion of the unmodified treadmill user interface that was used in the final design was a compartment housing the dead man switch safety mechanism. Although not specifically part of the user interface by our definition, the mechanism was physically attached to the original panel and needed to be removed with a band saw so that it could be independently attached to the tread mill so that its features could remain available.

4. Results and Analysis

4.1 *Final Walking Surface*

To assemble to install the new walking surface it was necessary to first remove the old. In order to do this a small amount of material had to be cut away from the plastic components at the ends of the rails as it prevented the particle board from sliding to the side. It was also necessary to bend one of the belt aligning brackets and remove the other. In order to prepare the treadmill to accept the new walking surface, the original metal mounting points were removed with a die grinder and the rubber supports extracted with pliers.

The aluminum plate was cut to size from stock using a band saw and a reciprocating saw. The two aligning brackets were attached with self-tapping screws to the underside of the aluminum plate in the same relative location as they were on the particle board. Because it was .5 inches thinner, there was little difficulty encountered in inserting the aluminum plate into the belt system. Two pairs of equally spaced holes were drilled through the through the plate and rails to accommodate bolts. Two .5 inch metal spacers to evenly support the metal plate at the appropriate height were cut to the length of the plate and drilled with sets holes match with the bolt holes. These strips were preferable to the original mounting points, because they support the plate along its entire length. Bolts were inserted with their heads that the top of the surface in order to limit their protrusion. Next the EVA foam was cut to size and inserted between the belt and the plate. Once proper alignment of the foam was confirmed, a multi-purpose spray adhesive was applied between the foam and the plate.

The group determined that the friction-reducing acrylic sheet should be only as wide as the belt itself, so that the non moving side rails of the treadmill would bear and exposed layer of high friction EVA foam, rather than smooth acrylic. The sheet was cut to size according the manufacturers directions; by scoring the lines with a knife and then bending the plastic over a sharp corner along the same lines, to snap it. To complete the walking surface, the acrylic sheet was inserted between the belt and the EVA foam with its textured side down and affixed with spray adhesive. Figure 14 shows a side view of the final walking surface installed on the treadmill.

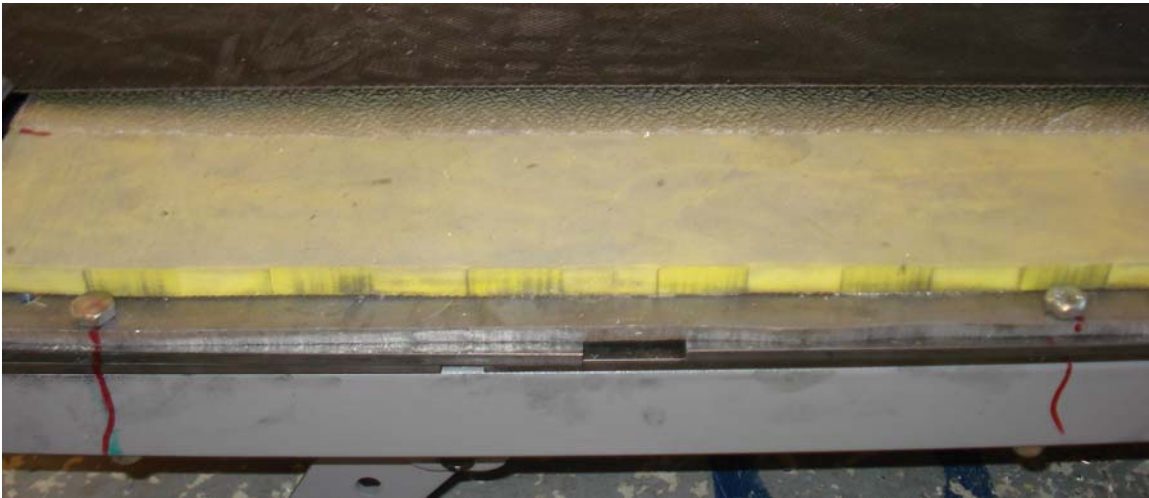

Figure 14: Final Walking Surface

4.2 Final Handrail Design

The final railing design consisted of four major components. These four components are the arms of the walker, the joint that holds the front walker legs to the surface, telescoping tubes, and joints that hold the telescoping tubes onto the walker arms. In order to use the arms in the final design, we had to isolate them from the middle section that connected them together. The first step to getting the walker apart was to remove a pair of brackets that were pop-riveted on to the arms preventing the middle section from sliding down the tubes that make up the arm. The next step was to remove the section of the front legs that telescopes downwards, and is where the wheels are connected. The wheels were removed from this section since they would not be needed on the treadmill. Removing the cross bars that span from front leg to back on the walker

allowed us to slide each arm out of the sleeve that connects the middle section to the arms. Once the arms had been isolated the cross bars were reattached.

To join the arms to the walking surface, we needed to design a joint that would allow for easy attachment and detachment of the walker as well as giving it one degree of freedom to pivot about an axis parallel to the long side of the walking surface. We decided to manufacture the joint in three pieces, a U-channel to be mounted to the walking surface, an upper half to the joint to connect to the walker, and a pin to connect the two halves of the joint together. The U-channel is made out of aluminum U-stock and has a 0.25 inch hole in it for a bolt to pass through and the pin is a standard 1/4-20 bolt. The upper half of the joint needed to be engineered. The first design was similar to the initial walker support mechanism with a pin that extends into the bottom of the front legs of the walker which would allow the walker to be removed easily, but would extend far enough into the leg so that it would not be likely to come off the joint. Figure 15

shows a CAD model of the proposed joint. One problem that was being considered concurrently with the designing of this joint is that once the middle section of the walker was removed, so went the mechanism that locked the walker arms at 90 degrees from the middle section. We needed another method for preventing the back legs of the walker from pivoting towards the belt or off the side of the treadmill. Given the joint design that was just outlined, we would have made a pocket in the walking surface for the back feet of the walker to sit in preventing the legs from straying undesirably. This plan had some drawbacks to it. The pocket would either have to be larger than the foot to make it easy to insert for the user, allowing the handgrips to pivot a little bit, or the pocket would have to fit tightly around the foot and be difficult for insertion, but

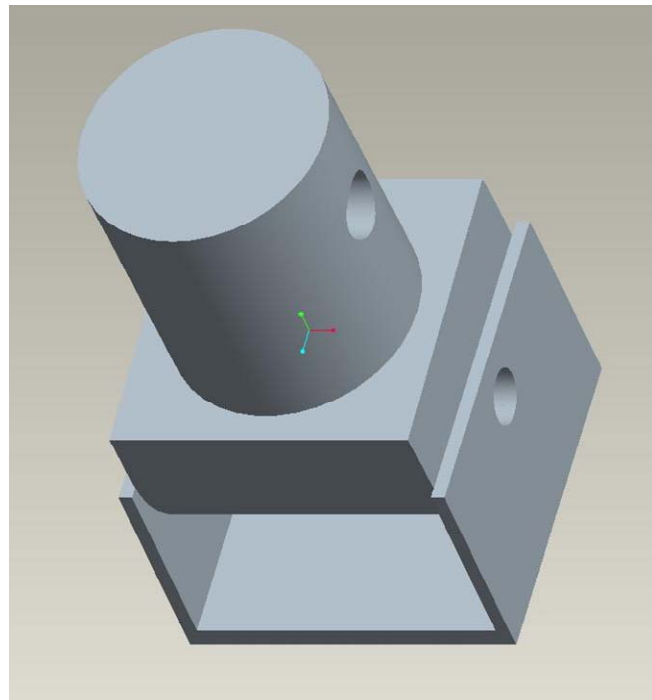

Figure 15: Initial Walker to Treadmill Joint Concept

back feet of the walker to sit in preventing the legs from straying undesirably. This plan had some drawbacks to it. The pocket would either have to be larger than the foot to make it easy to insert for the user, allowing the handgrips to pivot a little bit, or the pocket would have to fit tightly around the foot and be difficult for insertion, but

providing more stability. Neither of these outcomes was desirable from a usability standpoint, and we decided to come up with another method for locking the position of the handrails.

The solution we came up with is to change the upper half of the joint to be a rectangular block with a hole in the top, rather than a pin on a rectangular base. This would allow us to insert the front feet of the walker into the cup instead of the feet onto a pin. The reason this design is more favorable is, as depicted in Figure 16, we have a hole on one side of the “cup” the leg is

inserted into. This hole mates with a push button that is mounted inside the walker leg, the same one that is used for the extension of the legs and for other parts of our design that will be discussed shortly. This allows us to lock the leg into the joint, preventing it from coming out as well as locking the arm at an angle parallel to the length of the long side of the walking surface. This design both prevents the back feet from moving any more than the compliance of the aluminum tubing allows and it makes it easy to install

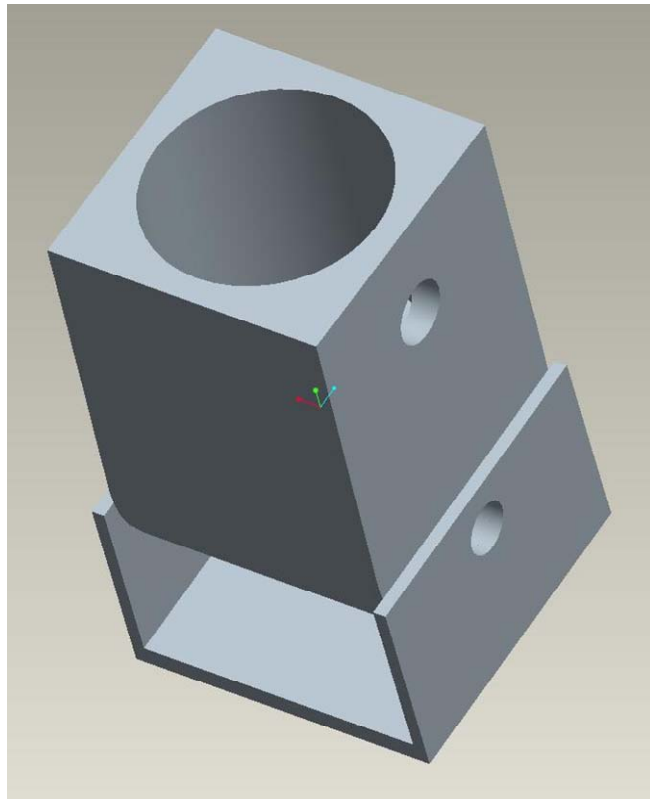

Figure 16: Final Walker to Treadmill Joint Concept

the walker onto the treadmill. The button does not take much force to depress and is additionally beneficial since it is the same adjustable fastener that is used on other parts of the treadmill, reducing complexity for the user. We decided that this joint was more appropriate for use on the treadmill and used it in the final design.

The next element of the design of the railing system is the telescoping tubes that are used to adjust the width of the hand grips on the walker. We needed to design this from the ground up because the stock Guardian Easy Care Folding Walker did not have any provisions for adjusting the width of the grips. We decided that the best way to

widen the walker was with a telescoping tube, to keep the same adjustment mechanism that is used to make the walker taller, also make it wider. A single tube spanning from one arm to another is all that is needed to adjust the width of the walker hand grips, however the cross member would need to be connected to the walker with a two degree of freedom joint. One degree of freedom is rotation about the axis parallel to the long edge of the walking surface, since the arm would be pivoting. The other degree of freedom would have to be along an axis running inside of the front leg of the walker, so when detached from the treadmill, the walker could be folded flat, as the stock model could, for ease of storage. The former degree of freedom, in conjunction with the joints at the walking surface, would create a parallelogram linkage with a joint at each corner.

This would cause the walker to fall to one side or another if it was not being held in place by an external source. To combat this, we decided to use two telescoping tubes crossing each other from the bottom left of the front leg of the walker to the top right, and the bottom right to the top left. If the tubes were adjusted to the same length, they would both keep the walker sturdy and the arms would have the same angle relative to the ground. The next step was to determine the relationship between the lengths of the telescoping tubes and the width of the hand grips. Using MathCAD we created a program that would provide us with the length of the telescoping cross tube when provided with handle width as an input. In researching the different widths we should allow for in the design, we discovered that the average shoulder width of a human is 16-26 inches. We used that information to select a range of selectable widths that would be comfortable for users. We ran the program with the following assumptions: the width between the joints on the walking surface is 23 inches, the four 2-degree of freedom joints that connect the cross tubes to the walker arms are butted up against the horizontal support bars of the arm, and that the widths of the handle grips are 17-26 inches in 1 inch increments. Table 2 is an output from that program showing the input width and the output length of the cross tube as well as the change in length of the tube from one width to another. The telescoping tubes would be made from two nested aluminum tubes with a button inside the smaller one and an array of holes in the larger one for the length adjustment. This is the same mechanism that is used to adjust the height of the stock walker, and we did not want to add complexity to the design.

The “Change in Length of the Telescoping Tube” column shown in Table 2 shows us how far apart to make the centers of the holes on the larger tube. For the sake of simplicity we decided to make that value a constant 0.54 inches rather than make the holes varying lengths apart. While that decision will affect the width between the hand grips, we decided that the widths are somewhat arbitrary in that a user would not walk up to the treadmill and look to set the width to a certain numeric value, as they would if they were looking to buy shoes. The desired width of the hand grips is more subjective and

users will still be well served with approximately one inch resolution in the adjustability of the grips. The buttons we are using for the telescoping tubes are about 5/16 (0.3125 inches) in diameter. At the desired resolution for the width of the hand grips of 1 inch, there would be very little space between the holes, roughly 0.2 inches. Even though there is

Width of Handle Grips (inches)	Length of Each Telescoping Tube (inches)	Change in Length of Telescoping Tube (inches)
17	23.753	X
18	24.275	0.522
19	24.8	0.525
20	25.327	0.527
21	25.858	0.531
22	26.391	0.533
23	26.926	0.535
24	27.463	0.537
25	28.003	0.54
26	28.544	0.541

Table 2: Lengths of the Telescoping Tubes for Given Widths

very little forces acting on the cross bars, since the weight of the user is transmitted largely downwards when they are leaning on the walker, there is still some risk of tearout between the holes, the tube would be difficult to manufacture, and it would be more difficult from a usability standpoint to adjust the width.

We decided that the best way to remedy the issue is to use two buttons, one located on either side (180 degrees apart) of the inner tube. This would allow us to have twice the distance between each hole on either side of the larger tube, increasing the resistance of the tube to tear out stress. The first idea of how to orient the buttons was to position them directly across from each other. We could then drill the holes in the larger tube, staggering them so that the odd width values (17in, 19in, 21in, etc.) were on one side of the large tube, and the evens were on the other side. This would still require complex machining to ensure that the holes were 180 degrees apart. In order to make the

machining process easier, we decided to put the offset between the holes in the buttons instead of the large tube. This allows us to drill holes through the larger tube, effectively making holes 180 degrees apart from each other, and spacing this set of holes twice the distance offset distance from each other ($0.54m * 2 = 1.08m$). This gives us the same resolution as the other two options, and it is significantly easier to manufacture. Figure 18 shows the cross arms on the walker.

The final element of the handrail/walker system is the 2-degree of freedom joints that connect the telescoping tubes to the walker arms. In order to make the two tubes cross over one another, we needed to create two sets of joints. One set would have to protrude away from the arms one inch further than the other to insure the larger one inch tubes did not interfere with each other. To connect the tubes to the joints, the ends of the blocks were threaded with a 1/4-20 tap so that a bolt could be screwed into the plastic,

securing the tube to the block. (Figure 17) These joints were made from blocks of plastic with a one inch hole cut in them. The hole was made just large enough so that the block could slide up the leg of the walker. The arm is free to rotate within the larger hole, the first degree of freedom, so the walker arms can fold up against the cross bars for storage purposes. The other degree of freedom is about the bolt threaded into the end of the

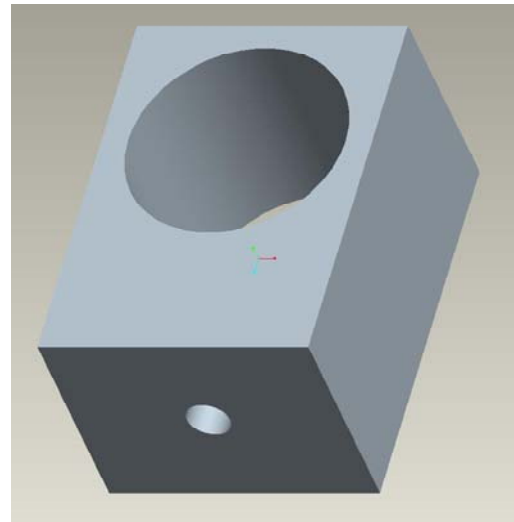

Figure 17: 2-Degree of Freedom Joint to Connect Telescoping Tubes to Walker Arms

block. The telescoping tube can pivot about that pin (bolt) as is necessary when adjusting the width of the grips. In order to keep the blocks up against the bars spanning from the front leg to the back leg on each of the arms, brackets were pop-riveted into the walker legs to sandwich the joints between that bracket and the bar. This ensures that the joints do not slide up or down, ensuring the distance between the upper and lower joint is constant. This is important because if the upper joints slide down, the width between the hand grips will grow, and if any one of the joints moves up or down, it will cause the arms to no longer be angled symmetrically relative to the ground. Such a condition could

present a safety concern, but sandwiching the joints prevents that from happening. The joints can be seen in the assembled walker in Figure 18.

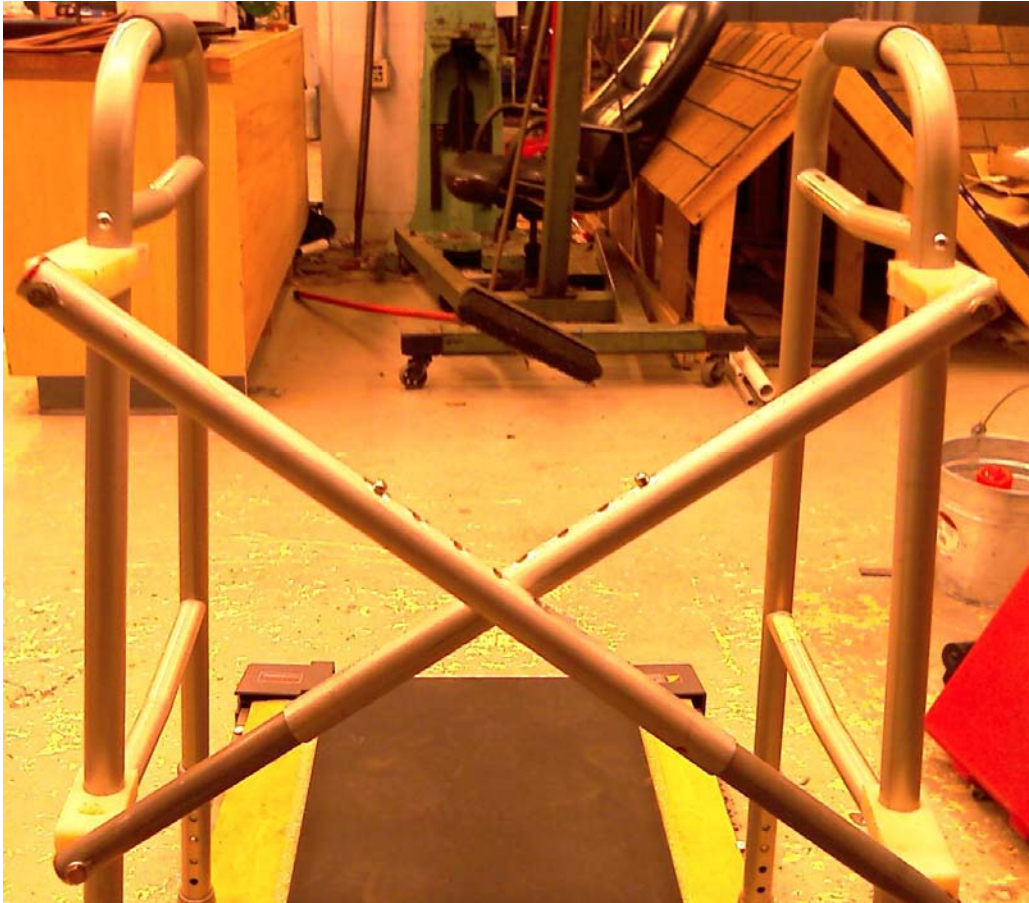

Figure 18: Telescoping Tubes Attached to the Walker Arms

4.3 Final Speed Reducer Design

The first step in finalizing the speed reducer design was making sure that all of its components could be machined. Our original design for the shaft collars was to make them square so that they could be assembled from four separate pieces (Figure 19). These pieces would have been permanently attached to one half of the shaft, with the other half sliding into it to complete the shaft. We eventually decided that this design would not be as effective as we had thought. We then redesigned the collars to be made from solid pieces of aluminum that would slide over the splits in the shafts. We decided to mill hexagonal holes into pieces of round stock aluminum, which would engage with

hexagonal sections of the shafts on either side of the splits. We had initially dismissed the possibility of machining the collars from solid pieces because of the tremendous difficulty involved in machining holes with sharp corners. To avoid this, we cut the hexagons with rounded corners first and then drilled out the corners (Figure 20). Although this introduced a small amount of play into the system, we determined that it would still allow for an adequate amount of contact between the shafts and the collars.

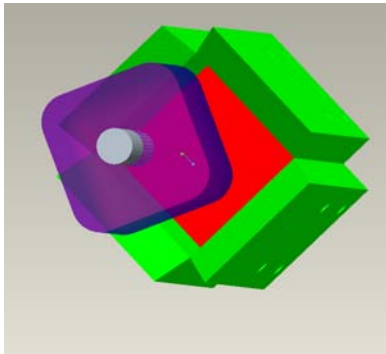

Figure 19: Initial Collar Design

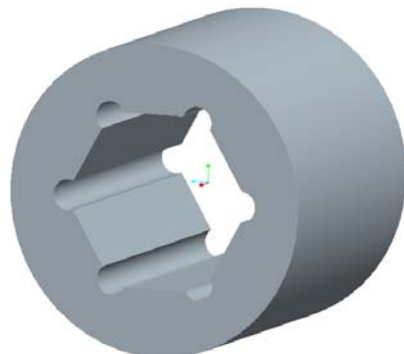

Figure 20: Final Collar Design

Once we knew all of our parts could be machined we analyzed the shafts to determine what their exact dimensions should be. Since the driver pulley was originally threaded onto the motor shaft, the new shafts had to be large enough to match these threads. We determined them to be $\frac{1}{2}$ -13 left-handed threads. This meant that the shafts needed a diameter greater than 0.5in so that the shaft that connected to the motor could have a $\frac{1}{2}$ -13 interior thread machined into it. From 0.5in, the increments by which we could increase the shaft diameter were limited by the available pulleys and bearings. The next largest diameter for which we could purchase pulleys and bearings was 0.75in. Based on our calculations (shown in Appendix A) we determined that using 0.75in diameter aluminum shafts would result in a safety factor of 9.44 for the upper shaft and 2.98 for the lower shaft.

To machine the shafts, we turned 0.75in hexagonal aluminum stock in a lathe until it was round. We left a hexagonal section at the end of each shaft for the collar to engage on. We also machined pockets on the hexagonal end of two of the shafts and small protrusions on the hexagonal ends of the other two shafts. This allowed us to place a small bearing between each pair of shafts to prevent deflection.

In order to function properly the left end of the lower shaft needed to thread onto the motor shaft and the right end of it needed to thread onto the driver pulley. Machining these threads proved more difficult than we expected. The interior threads for the motor end were fairly simple. We drilled out a hole of the appropriate size, using a lathe to make sure that it was centered on the shaft. Then we used a tap to add threads to the hole. The most difficult part was making sure that the hole was centered and the threads were straight. This was important because otherwise the shaft would have been unbalanced. The exterior threads for the driver pulley end were significantly more difficult. With some help from Troy Coverstone, a work study in the campus machine shop, we programmed a CNC lathe to machine the threads. But the threads the program produced when we ran it on a test piece of aluminum did not match up with the threads on the pulley. After examining the machine, we determined that we did not have the threading tool in the proper orientation for machining left-hand threads. Even after we repositioned the tool, the lathe was not producing adequate threads. The tool did not appear to be traveling deep enough into the part. For the final part, we ended up machining the threads with a slightly modified program, and then running an exterior tap over them to make sure that they were deep enough.

The mounting system for the final design for the speed reducer was also slightly modified from the original design. Instead of being mounted horizontally, the two shafts were mounted vertically. This was done to avoid increasing the overall footprint of the treadmill. Also, the mounting brackets were placed on pieces of 80/20 Aluminum. This allows the user to tension the belt that runs to the treadmill by simply loosening the brackets and sliding them along the channels in the 80/20. To allow the user to tension the other two belts, the brackets for the upper bearings were connected to the lower brackets with threaded rod. The position of the upper

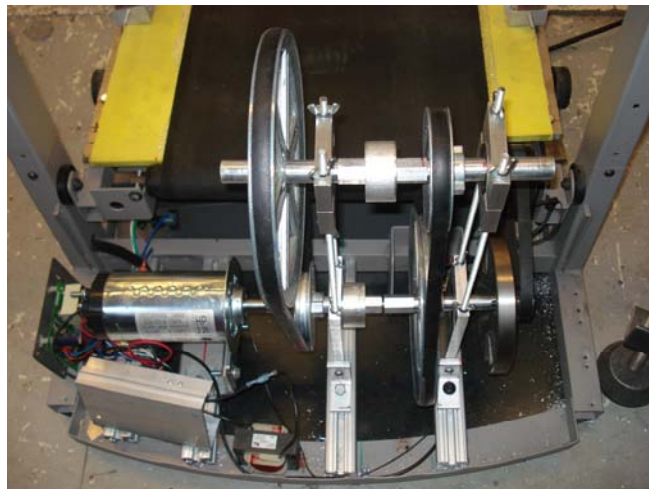

Figure 21: Final Speed Reducer

brackets can be changed by moving the nuts that support them along the threaded rod. Figure 21 shows the final speed reducer mounted on the treadmill.

One piece of the initial design that we were unable to machine was the shifting mechanism. The speed reducer still functions as intended; the only difference is that the user needs to change the collars individually. The shafts are still assembled with the splits offset from each other so that the two collars could be engaged and disengaged simultaneously by the same mechanism.

4.4 Final User Interface Design

A user interface designed for elderly users must take into account several common inconveniences that people often experience as they age. The first of these is a decrease in visual acuity. Vision problems are virtually unavoidable with age. Most people begin to notice some decrease in vision around the age of 40. The most common vision difficulties are those associated with poor focus of the lens of the eye. In addition to the common genetic traits of myopia and hyperopia, which restrict the ability of the eye to focus at far and near distances respectively, there is a condition known as presbyopia. Presbyopia is a natural aspect of the aging process resulting from the stiffening of the lens of the eye as well as the weakening of the muscles that control and shape it. The result of this is a continual decrease in ability to focus on near objects as one ages. One technique to compensate for this condition is to simply use very large images or print, such that the ratio of size between the object viewed and the so called circle of confusion caused by lack of focus is very large. Additionally, as the overall brightness of a scene increases, the eye naturally responds by constricting the iris to limit the amount of light reaching the retina. An advantageous side effect of this process is that a tightly constricted iris develops optical properties similar to those of a pin-hole camera which supplement the action of the unfocused lens and decrease the size of the circle of confusion. The tendency of the iris to mitigate the effects of poor focus can in fact improve with age due to *senile miosis* which causes the pupil of the eye to constrict. The disadvantage of *senile miosis* is that it permanently limits the amount of light that reaches the retina, thus decreasing the overall brightness of one's vision. This restriction can make it very difficult for a person to recognize details in dark images.

In addition to the mechanical aspects of the eye, it is important to consider chemical and biological conditions that may influence vision. True colorblindness, although not a condition caused by aging, is a serious vision concern for the design of a user interface. One must ensure that different words and symbols can be distinguished from their background. Those born with full color vision may experience a decreased sensitivity to color with aging. This is due to the loss of cone cells in the retina, which detect the color of light. However this problem occurs most in the periphery of vision and can be remedied with increased illumination.

The lens and humor of the eye naturally contains yellow pigments, which serve to filter ultraviolet light. As one ages, the quantities of these pigments present in the eye increase and cause ones vision to develop a significant yellow tint. The absorption of short wavelengths of light can make it very difficult to distinguish between greens and blues and to a lesser degree between yellows and reds. As is the case with the loss of cones, increased brightness can improve the quality of vision.

The original user interface of the unmodified treadmill (Figure 22) was a single flat surface bearing a printed image. The buttons to control the device were flexible areas on that surface, which when pressed would deflect to make contact with small switches soldered directly to a circuit board within the console. The total deflection of any of these surfaces was no more than one millimeter.

There were changes no in the shape or texture of the plastic surface to indicate the location. Initial attempts by the project teams to operate the treadmill immediately determined that it was impossible to gain any kind useful tactile information from the user interface in order to supplement visual information.



Figure 22: Original User Interface

In order to assess the viability of the original user interface and aspects of any new interfaces, a number of digital simulations were developed in order to replicate the effects of aging in photographs and images. The image used to create the original user interface relied upon dark grey as the primary background color. The text used to

indicate the purpose of controls was a small and thin white font. The buttons to control speed and incline were a gradient of light grey and white with small arrows of either black or red. The stop button was a relatively large oval shaped button.

Before any digital vision simulations were applied to photographs of the original user interface an unexpected flaw was identified. The clear plastic sheet under which the interface image lay displayed a strong tendency to reflect incident light, creating severe glare. In some test photographs portions of the interface were rendered completely unreadable by glare alone. Images without glare were used for the subsequent testing. To simulate poor focusing of the image a two dimensional low-pass filter known as a box blur was applied to the image. This technique was selected instead of the much more common Gaussian blur filter used in photo editing, because the low-pass filter more closely replicates the image distortions caused by an improperly focused lens. Simple reduction of the brightness and contrast of the image was used to simulate narrowing of the pupil, decreased sensitivity of the retina and loss of light due to the yellowing of the lens. Reduction of the intensity of the blue range simulated the color effects of yellowing of the lens and similar reduction of the red channel simulated red-green color blindness.

These tests showed that the overall brightness and contrast levels of the original were much too low to maintain suitable visibility in the presence of visual impairment. Distinction between the arrow buttons and the background image faded to almost nothing. The blur effect of the low pass filter exacerbated these effects and reduced or eliminated the readability of the text. Through these first changes, the red stop button remained clearly identifiable by virtue of being a distinct color and being larger than any circle of confusion caused by the box blur, however once the red channel of the image was reduced, the stop button quickly became indistinguishable from the other features.

The conclusion reached from these simulations was that the original unmodified user interface was completely inadequate for use by the elderly and otherwise visually impaired individuals. In order to supplement this information, test images composed of six colors of text on backgrounds of the same colors were subjected to simulations of three common forms of color blindness called Protanopia, Deuteranopia and Tritanopia. The results of these simulations were used to determine pairs of colors that remain easy to distinguish from one another despite a lack of color sensitivity.



Figure 23: New User Interface

5. Conclusions and Recommendations

5.1 Walking Surface

The new walking surface that we installed on the treadmill is a significant improvement over the previous surface. The foam padding is substantially more compliant than the original particle board. This will result in less of the force from a user's foot impacting the surface being transmitted through the user's leg, protecting sensitive joints such as the knee and ankle. While it does add a significant amount of weight, the aluminum plate is necessary to add structure to the foam. A surface made entirely from the foam would not be able to support a user's weight.

There is very little that could be done to improve our walking surface, given the current configuration of the treadmill's belt. If the treadmill were altered to use larger rollers to drive the belt, this would allow more space between the belt and the frame of the treadmill. This additional space would allow for a thicker support plate. With a thicker support plate, holes could be drilled to reduce weight. The amount of material that could be removed in this way would be greater than the amount added by the additional thickness for certain thickness levels. As our analysis showed, such holes are not an option on any plate that would currently be able to fit on the treadmill.

5.2 Handrails

The following are a few recommendations for the handrail system of our treadmill. The walker should be mounted closer to the user interface to make the controls easier to access. Currently the walker is positioned several inches further back than need be and users would likely benefit from the change. Due to manufacturing issues, the joint that joins the walker to the surface of the treadmill was made out of wood. The joints should be machined out of aluminum so the thickness between the cup the walker leg sits in and the outer face of the block is minimized to facilitate the use of the button that secures the leg in place. The base of the joint should also be mounted with a slight tilt to match the angle of the leg of the walker relative to ground. This will minimize the amount of stress in the joint pin. Some sort of color coding or markings should be added to the telescoping cross arms that identify what hole and button corresponds to what width between the grips on the walker, and they should also indicate that the tubes should

both be extended to the same position any time a change is made, to ensure that the tubes are of equal length and the walker arms are at a symmetric angle relative to ground. The cross bars connecting the arms together should be connected using two sleeves rather than the current arrangement of four blocks on the arms of the walker. This will increase the rigidity and stability of the walker, making it more comfortable for use. Finally, an additional safety feature that can be added to the walker is to have switches in the hand grips. These switches would cut power to the motor of the treadmill unless they were both depressed at the same time. This would ensure that the user is holding onto the walker when using the treadmill, and if they were to fall or need to stop quickly the act of removing their hands from the grips would halt the operation of the device. The switches should be wired such that they plug into the user interface so when the walker is removed from the treadmill for storage the wires are not in the way.

5.3 *Speed Reducer*

In general, the final speed reducer we added to the treadmill could be improved in a few ways. The first of these is adding a mechanism to shift the shaft collars. Set up as it is currently the user must manually move each collar individually. Our original horizontal design did call for a mechanism that would engage one collar while simultaneously disengaging the other. However, after changing the orientation of the speed reducer we did not have adequate time to redesign and machine a new shifter. Another improvement that could be made given more time would be the addition of a cover for the entire assembly. Given the size of the speed reducer, the original treadmill cover would not fit back in place after it was installed. A replacement cover could be formed out of plastic or sheet metal.

While the mechanical speed reducer is the best solution that we could implement, given our individual skill sets, it is not an ideal solution to the problem of finer speed control. A better solution would be to alter the circuitry of the treadmill to allow for operation at lower speeds and finer speed control. As mentioned before, this is what the previous project attempted, but their lack of electronics knowledge prevented them from implementing it successfully.

5.4 User Interface

The user interface that we designed is a significant improvement over the one that was originally on the treadmill. The buttons are significantly easier to distinguish, both by sight and by touch. The bright colors on the buttons are a stark contrast to the black background. The dramatic corners of the buttons make their shapes more recognizable. The buttons are also more responsive, so it is easier for a user to determine whether or not they have been fully depressed. Finally, the use of common over learned shapes, such as a red octagon for the stop button, makes the interface more familiar and intuitive for users.

One aspect of our original design that we were not able to bring to fruition was incorporating the treadmill's original LCD displays into our new interface. Our intent was to leave the circuit that controlled them unmodified and mount the old displays to our interface once it was installed. Unfortunately, constructing our user interface took longer than we anticipated, so we did not have enough time to do this.

5.5 Comparison to Previous Prototype

When compared to the prototype built by the previous group, our final design is an improvement in virtually every aspect. The most noticeable improvements can be seen in the size and weight of the additions made to the treadmills. In both projects, the original treadmills were comparable to each other. They both had the same overall footprint, and they both weighed relatively the same amount. The previous group's modifications increased the footprint of their treadmill from 25 inches by 60 inches to 48 inches by 64 inches. Their modifications also added more than 120 pounds of additional weight to their treadmill. In comparison, our modifications do not add any area to the footprint of our treadmill. The footprint is the same as it was before, 25 inches by 60 inches. The overall weight of the components we added to our treadmill was 53 pounds. But our modifications also included removing some pieces of the treadmill, specifically the original walking surface and the unnecessary upper body workout bars. Together these items weighed 25 pounds, so the net change in weight of our treadmill was only 28 pounds.

The other major difference between our prototype and the one developed by the previous group is ease of transport. Moving the previous prototype required partially

disassembling the support structure for the handrails and the harness. To move our prototype, a user must simply remove the walker from the walking surface, and the treadmill will fold up and move as originally designed.

References

- Barratt, J. "Design for an Ageing Society". *Gerontechnology*. (October 2007 p. 188-189)
- Cha Yau Sponge Enterprise Co Ltd. (2008), "EVA foam mat specifications," Retrieved January 13, 2008 from http://sourcing.hktdc.com/cgi-bin/hekei.dll/Jsp/hkei/Template_ProductDetail.cmd?ProductOID=230573&MemberID=843105&Enq=no
- DINOFLEX Manufacturing LTD. (2002), "Technical Specifications: Playground Rubber Tiles and Playtiles, Retrieved January 10, 2008 from http://www.dinoflex.com/pdf/Specs-Playground_Rubber_Tile.pdf
- FastFloors.com. (2007). *Bounce Back - 3 Feet Fall Flat Tile*. Retrieved September 20, 2007, from FastFloors.com: http://www.fastfloors.com/style_18613,0/Rubber-Products-Bounce-Back--3-Feet-Fall-Flat-Tile.htm
- Fisk, Arthur D., Wendy A. Rogers, Neil Charness, Sara J. Czaja, Joseph Sharit. (2004). *Designing for Older Adults: Principles and Creative Human Factors Approaches*. New York: CRC Press LLC
- GreatMats.com Corporation. (2007). *Patio Paver Tile*. Retrieved September 20, 2007, from GreatMats.com: http://www.greatmats.com/products/patio-paver-tile.html?gclid=CLG11Juq6I8CFQMsFQodPU_Q6w
- Homer TLC, Inc. (2007). *Shop HomeDepot.com*. Retrieved September 20, 2007, from HomeDepot.com: <http://www.homedepot.com>
- Hospeq, Inc. (2008). *Walkers, Canes, and Crutches*. Retrieved February 1, 2008, from RehabOutlet.com: http://www.rehaboutlet.com/walkers_can.htm
- ICON Health & Fitness, Inc. (2003). *ProForm Cross Walk 325 User's Manual*. USA.
- Kelley, D. S. (2005). *Pro/Engineer Wildfire Instructor*. New York: McGraw-Hill.
- Norton, R. L. (2006). *Machine Design An Integrated Approach* (3rd Edition ed.). Upper Saddle River, NJ: Pearson Prentice Hall.
- Phillips, Chandler Allen. (2000). *Human Factors Engineering*. New York: John Wiley & Sons, Inc.

R&D Ergonomics Incorporated. (n.d.). *Sizing Guidelines*. Retrieved January 26, 2008, from R&D Ergonomics Comfortable Computing: <http://www.morencyrest.com/sizing.htm>

Scovil, C.Y., P. Corbeil, T.A. Lee, S.M. McKay, A.L. Peters, B.E. Maki. "A Novel Handrail Cueing System to Prevent Falls in Older Adults". *Gerontechnology*. (October 2007, p.224-229)

Surface America Incorporated. (2007). *PlayBound Poured-in-Place*. Retrieved September 20, 2007, from Surface America, Inc. | Playground Surfacing Systems: <http://www.surfaceamerica.com/index.php/products/details/playbound-poured-in-place/>

Appendix A

General Calculations

Given Values

Maximum Treadmill Speed	$S_{\max} := 10 \frac{\text{mi}}{\text{hr}}$
Roller Diameter	$D_R := 1.6\text{in}$
Roller Pulley Diameter	$D_r := 3.5\text{in}$
Driver Pulley Diameter	$D_d := 1.4\text{in}$
Motor Peak Power	$P := 2.5\text{hp}$
Weight Density of Aluminum	$\gamma_{\text{Al}} := 0.1 \frac{\text{lb}}{\text{in}^3}$
Ultimate Tensile Strength of Aluminum 6061	$S_{\text{ut}} := 18\text{ksi}$

Calculations

Maximum Shaft Angular Velocity	$\omega := \frac{S_{\max}}{\pi \cdot D_R} \cdot \frac{D_r}{D_d}$	$\omega = 5252.113\text{min}^{-1}$
Maximum Torque	$T_{\max} := \frac{P}{\omega}$	$T_{\max} = 188.496\text{lb}\cdot\text{in}$

Upper Shaft

Given

Shaft Diameter	$D_s := 0.75\text{in}$
Bearing and Pulley Locations	$L := 10.5\text{in}$
	$a := 2\text{in}$
	$b := 3.5\text{in}$
	$c := 7\text{in}$
	$d := 9\text{in}$
Weight of Pulley 1 (9in)	$W_1 := 1.4\text{lb}$
Belt Tension on Pulley 1	$T_1 := 40\text{lb}$
Weight of Pulley 2 (4in)	$W_2 := 0.6\text{lb}$
Belt Tension on Pulley 2	$T_2 := 40\text{lb}$

Upper Shaft Free Body Diagram

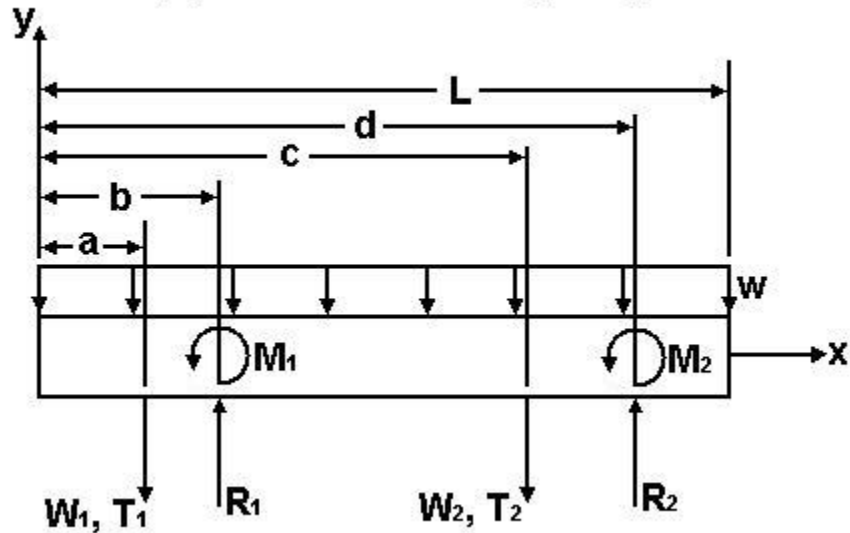

Calculations

Distributed Load (shaft weight)

$$w := \left(0.25 \cdot \pi \cdot D_s^2\right) \cdot \gamma_{Al} \quad w = 0.044 \frac{\text{lbf}}{\text{in}}$$

Singularity Functions

C_1 and C_2 can be assumed to be zero for all calculations

$$q(x) = w \langle x-0 \rangle^0 - (W_1 + T_1) \langle x-a \rangle^{-1} + R_1 \langle x-b \rangle^{-1} + M_1 \langle x-b \rangle^{-2} - (W_2 + T_2) \langle x-c \rangle^{-1} + R_2 \langle x-d \rangle^{-1} + M_2 \langle x-d \rangle^{-2}$$

$$x := 0, 0.01 \cdot L \dots L$$

$$S(x, z) := \text{if}(x \geq z, 1, 0)$$

$$V(x) = w \cdot S(x, 0) \cdot (x-0)^1 - (W_1 + T_1) \cdot S(x, a) \cdot (x-a)^0 + R_1 \cdot S(x, b) \cdot (x-b)^0 \dots \\ + M_1 \cdot S(x, b) \cdot (x-b)^{-1} - (W_2 + T_2) \cdot S(x, c) \cdot (x-c)^0 + R_2 \cdot S(x, d) \cdot (x-d)^0 + M_2 \cdot S(x, d) \cdot (x-d)^{-1} + C_1$$

$$M(x) = w \cdot S(x, 0) \cdot (x-0)^2 - (W_1 + T_1) \cdot S(x, a) \cdot (x-a)^1 + R_1 \cdot S(x, b) \cdot (x-b)^1 \dots \\ + M_1 \cdot S(x, b) \cdot (x-b)^0 - (W_2 + T_2) \cdot S(x, c) \cdot (x-c)^1 + R_2 \cdot S(x, d) \cdot (x-d)^1 + M_2 \cdot S(x, d) \cdot (x-d)^0 + C_1 \cdot x + C_2$$

Assumed values for solve block

$$R_1 := 100 \text{lbf} \quad R_2 := 100 \text{lbf} \quad M_1 := 10 \text{lbf} \cdot \text{in} \quad M_2 := 10 \text{lbf} \cdot \text{in}$$

Given

$$0 = w \cdot S(b, 0) \cdot (b-0)^1 - (W_1 + T_1) \cdot S(b, a) \cdot (b-a)^0 + R_1 \cdot S(b, b) \cdot (b-b)^0 - (W_2 + T_2) \cdot S(b, c) \cdot (b-c)^0 \dots \\ + R_2 \cdot S(b, d) \cdot (b-d)^0$$

$$0 = w \cdot S(d, 0) \cdot (d-0)^1 - (W_1 + T_1) \cdot S(d, a) \cdot (d-a)^0 + R_1 \cdot S(d, b) \cdot (d-b)^0 - (W_2 + T_2) \cdot S(d, c) \cdot (d-c)^0 \dots \\ + R_2 \cdot S(d, d) \cdot (d-d)^0$$

$$\begin{pmatrix} R_1 \\ R_2 \end{pmatrix} := \text{Find}(R_1, R_2)$$

Reaction Forces

$$R_1 = 41.245\text{lbf}$$

$$R_2 = 40.357\text{lbf}$$

Given

$$0 = w \cdot S(b, 0) \cdot (b - 0)^2 - (W_1 + T_1) \cdot S(b, a) \cdot (b - a)^1 + R_1 \cdot S(b, b) \cdot (b - b)^1 \dots$$

$$+ M_1 \cdot S(b, b) \cdot (b - b)^0 - (W_2 + T_2) \cdot S(b, c) \cdot (b - c)^1 + R_2 \cdot S(b, d) \cdot (b - d)^1 + M_2 \cdot S(b, d) \cdot (b - d)^0$$

$$0 = w \cdot S(d, 0) \cdot (d - 0)^2 - (W_1 + T_1) \cdot S(d, a) \cdot (d - a)^1 + R_1 \cdot S(d, b) \cdot (d - b)^1 \dots$$

$$+ M_1 \cdot S(d, b) \cdot (d - b)^0 - (W_2 + T_2) \cdot S(d, c) \cdot (d - c)^1 + R_2 \cdot S(d, d) \cdot (d - d)^1 + M_2 \cdot S(d, d) \cdot (d - d)^0$$

$$\begin{pmatrix} M_1 \\ M_2 \end{pmatrix} := \text{Find}(M_1, M_2)$$

Reaction Moments

$$M_1 = 61.559\text{lbf}\cdot\text{in}$$

$$M_2 = 79.013\text{lbf}\cdot\text{in}$$

$$M(x) := w \cdot S(x, 0) \cdot (x - 0)^2 - (W_1 + T_1) \cdot S(x, a) \cdot (x - a)^1 + R_1 \cdot S(x, b) \cdot (x - b)^1 \dots$$

$$+ M_1 \cdot S(x, b) \cdot (x - b)^0 - (W_2 + T_2) \cdot S(x, c) \cdot (x - c)^1 + R_2 \cdot S(x, d) \cdot (x - d)^1 + M_2 \cdot S(x, d) \cdot (x - d)^0$$

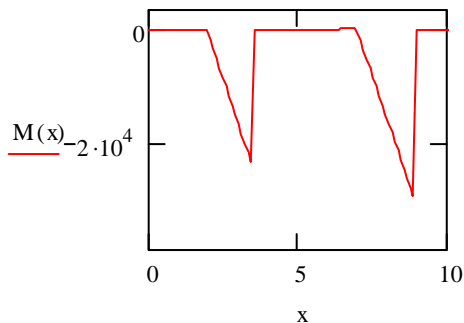

Critical Section

$$M(8.99999\text{in}) = -79.013\text{lbf}\cdot\text{in}$$

Maximum Stress

$$\sigma_{\max} = K \cdot \frac{M_{\max} \cdot c}{I}$$

Stress Concentration Factor

$$K := 0$$

Simplified Stress for Round Cross-Section

$$\sigma_{\max} := \frac{32M(8.99999\text{in})}{\pi \cdot D_s^3} \quad \sigma_{\max} = -1.908 \times 10^3 \text{ psi}$$

Safety Factor

$$N := \left| \frac{S_{ut}}{\sigma_{\max}} \right| \quad N = 9.435$$

Upper Shaft

Given

Shaft Diameter	$D_s := 0.75\text{in}$	
Bearing and Pulley Locations	$L := 11\text{in}$	
	$a := 1.75\text{in}$	
	$b := 3.25\text{in}$	
	$c := 6.75\text{in}$	
	$d := 8.75\text{in}$	
Weight of Pulley 1 (4in)	$W_1 := 0.6\text{bf}$	
Belt Tension on Pulley 1	$T_1 := 40\text{bf}$	
Weight of Pulley 2 (9in)	$W_2 := 1.4\text{bf}$	
Belt Tension on Pulley 2	$T_2 := 40\text{bf}$	
Weight of Pulley 3 (driver pulley)	$W_3 := 7\text{bf}$	
Tension on Pulley 3	$T_3 := 50\text{bf}$	
Angle of Belt 3	$\theta := 15\text{deg}$	
Components of Tension on Pulley 3	$T_{3y} := T_3 \cdot \sin(\theta)$	$T_{3y} = 12.941\text{bf}$
	$T_{3z} := T_3 \cdot \cos(\theta)$	$T_{3z} = 48.296\text{bf}$

Lower Shaft Free Body Diagram (x-y plane)

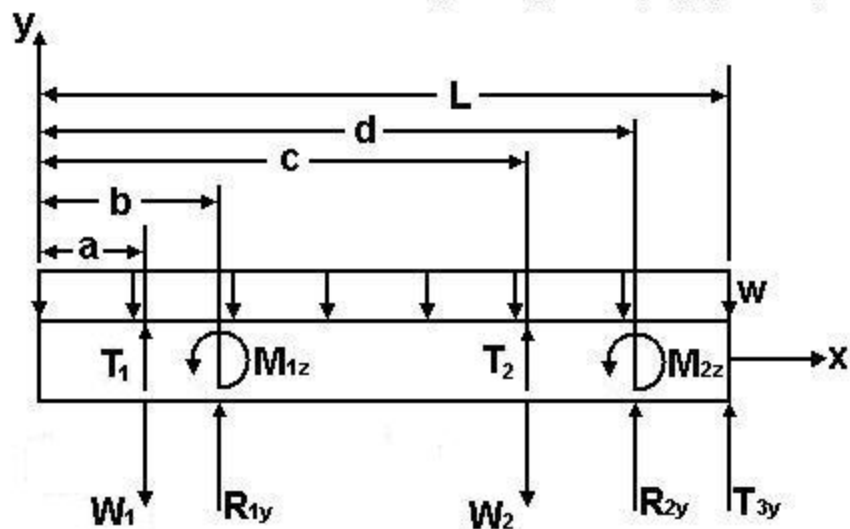

Lower Shaft Free Body Diagram (x-z plane)

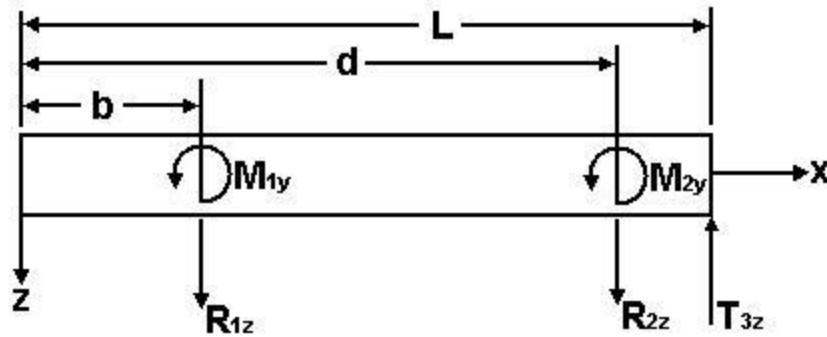

Calculations

Distributed Load (shaft weight)

$$w := \left(0.25 \pi \cdot D_s^2\right) \cdot \gamma_{Al}$$

$$w = 0.044 \frac{\text{lbf}}{\text{in}}$$

Singularity Functions

C_1 and C_2 can be assumed to be zero for all calculations

$$q_x(x) = w \langle x-0 \rangle^0 + (T_1 - W_1) \langle x-a \rangle^{-1} + R_{1x} \langle x-b \rangle^{-1} + M_{1x} \langle x-b \rangle^{-2} + (T_2 - W_2) \langle x-c \rangle^{-1} \\ + R_{2x} \langle x-d \rangle^{-1} + M_{2x} \langle x-d \rangle^{-2} - W_3 \langle x-L \rangle^{-1} + T_{3x} \langle x-L \rangle^{-1}$$

$$q_y(x) = R_{1y} \langle x-b \rangle^{-1} + M_{1y} \langle x-b \rangle^{-2} + R_{2y} \langle x-d \rangle^{-1} + M_{2y} \langle x-d \rangle^{-2} - T_{3y} \langle x-L \rangle^{-1}$$

$$x := 0, 0.01 \cdot L \dots L$$

$$S(x, z) := \text{if}(x \geq z, 1, 0)$$

$$V_x(x) = w \cdot S(x, 0) \cdot (x-0)^1 + (T_1 - W_1) \cdot S(x, a) \cdot (x-a)^0 + R_{1y} \cdot S(x, b) \cdot (x-b)^0 + M_{1z} \cdot S(x, b) \cdot (x-b)^{-1} \dots \\ + (T_2 - W_2) \cdot S(x, c) \cdot (x-c)^0 + R_{2y} \cdot S(x, d) \cdot (x-d)^0 + M_{2z} \cdot S(x, d) \cdot (x-d)^{-1} - W_3 \cdot S(x, L) \cdot (x-L)^0 \dots \\ + T_{3y} \cdot S(x, L) \cdot (x-L)^0 + C_1$$

$$V_y(x) = R_{1z} \cdot S(x, b) \cdot (x-b)^0 + M_{1y} \cdot S(x, b) \cdot (x-b)^{-1} + R_{2z} \cdot S(x, d) \cdot (x-d)^0 \dots \\ + M_{2y} \cdot S(x, d) \cdot (x-d)^{-1} - T_{3z} \cdot S(x, L) \cdot (x-L)^0 + C_1$$

$$M_x(x) = w \cdot S(x, 0) \cdot (x-0)^2 + (T_1 - W_1) \cdot S(x, a) \cdot (x-a)^1 + R_{1y} \cdot S(x, b) \cdot (x-b)^1 \dots \\ + M_{1z} \cdot S(x, b) \cdot (x-b)^0 + (T_2 - W_2) \cdot S(x, c) \cdot (x-c)^1 + R_{2y} \cdot S(x, d) \cdot (x-d)^1 \dots \\ + M_{2z} \cdot S(x, d) \cdot (x-d)^0 - W_3 \cdot S(x, L) \cdot (x-L)^1 + T_{3y} \cdot S(x, L) \cdot (x-L)^1 + C_1 \cdot x + C_2$$

$$M_y(x) = R_{1z} \cdot S(x, b) \cdot (x-b)^1 + M_{1y} \cdot S(x, b) \cdot (x-b)^0 + R_{2z} \cdot S(x, d) \cdot (x-d)^1 \dots \\ + M_{2y} \cdot S(x, d) \cdot (x-d)^0 - T_{3z} \cdot S(x, L) \cdot (x-L)^1 + C_1 \cdot x + C_2$$

In order to properly solve, these singularity functions must be written from the right end of the shaft instead of the left side. Therefore, x' will denote the same position as x but measured from the right end instead of the left end. $a' := L - a$ $b' := L - b$ $c' := L - c$ $d' := L - d$ $L' := L - L$

Assumed values for solve block

$$R_{1y} := 100\text{bf} \quad R_{2y} := 100\text{bf} \quad R_{1z} := 100\text{bf} \quad R_{2z} := 100\text{bf}$$

$$M_{1z} := 10\text{bf}\cdot\text{in} \quad M_{2z} := 10\text{bf}\cdot\text{in} \quad M_{1y} := 10\text{bf}\cdot\text{in} \quad M_{2y} := 10\text{bf}\cdot\text{in}$$

Given

$$0 = w \cdot S(b', L) \cdot (b' - L)^1 + (T_1 - W_1) \cdot S(b', a') \cdot (b' - a')^0 + R_{1y} \cdot S(b', b') \cdot (b' - b')^0 + (T_2 - W_2) \cdot S(b', c') \cdot (b' - c')^0 \dots$$

$$+ R_{2y} \cdot S(b', d') \cdot (b' - d')^0 - W_3 \cdot S(b', L) \cdot (b' - L)^0 + T_{3y} \cdot S(b', L) \cdot (b' - L)^0$$

$$0 = w \cdot S(d', L) \cdot (d' - L)^1 + (T_1 - W_1) \cdot S(d', a') \cdot (d' - a')^0 + R_{1y} \cdot S(d', b') \cdot (d' - b')^0 + (T_2 - W_2) \cdot S(d', c') \cdot (d' - c')^0 \dots$$

$$+ R_{2y} \cdot S(d', d') \cdot (d' - d')^0 - W_3 \cdot S(d', L) \cdot (d' - L)^0 + T_{3y} \cdot S(d', L) \cdot (d' - L)^0$$

$$\begin{pmatrix} R_{1y} \\ R_{2y} \end{pmatrix} := \text{Find}(R_{1y}, R_{2y})$$

Reaction Forces

$$R_{1y} = -38.6\text{bf} \quad R_{2y} = -5.941\text{bf}$$

Given

$$0 = w \cdot S(b', L) \cdot (b' - L)^2 + (T_1 - W_1) \cdot S(b', a') \cdot (b' - a')^1 + R_{1y} \cdot S(b', b') \cdot (b' - b')^1 \dots$$

$$+ M_{1z} \cdot S(b', b') \cdot (b' - b')^0 + (T_2 - W_2) \cdot S(b', c') \cdot (b' - c')^1 + R_{2y} \cdot S(b', d') \cdot (b' - d')^1 \dots$$

$$+ M_{2z} \cdot S(b', d') \cdot (b' - d')^0 - W_3 \cdot S(b', L) \cdot (b' - L)^1 + T_{3y} \cdot S(b', L) \cdot (b' - L)^1$$

$$0 = w \cdot S(d', L) \cdot (d' - L)^2 + (T_1 - W_1) \cdot S(d', a') \cdot (d' - a')^1 + R_{1y} \cdot S(d', b') \cdot (d' - b')^1 \dots$$

$$+ M_{1z} \cdot S(d', b') \cdot (d' - b')^0 + (T_2 - W_2) \cdot S(d', c') \cdot (d' - c')^1 + R_{2y} \cdot S(d', d') \cdot (d' - d')^1 \dots$$

$$+ M_{2z} \cdot S(d', d') \cdot (d' - d')^0 - W_3 \cdot S(d', L) \cdot (d' - L)^1 + T_{3y} \cdot S(d', L) \cdot (d' - L)^1$$

$$\begin{pmatrix} M_{1z} \\ M_{2z} \end{pmatrix} := \text{Find}(M_{1z}, M_{2z})$$

Reaction Moments

$$M_{1z} = -135.1\text{bf}\cdot\text{in} \quad M_{2z} = -13.367\text{bf}\cdot\text{in}$$

$$M_x(x) := w \cdot S(x, L) \cdot (x - L)^2 + (T_1 - W_1) \cdot S(x, a') \cdot (x - a')^1 + R_{1y} \cdot S(x, b') \cdot (x - b')^1 \dots$$

$$+ M_{1z} \cdot S(x, b') \cdot (x - b')^0 + (T_2 - W_2) \cdot S(x, c') \cdot (x - c')^1 + R_{2y} \cdot S(x, d') \cdot (x - d')^1 \dots$$

$$+ M_{2z} \cdot S(x, d') \cdot (x - d')^0 - W_3 \cdot S(x, L) \cdot (x - L)^1 + T_{3y} \cdot S(x, L) \cdot (x - L)^1$$

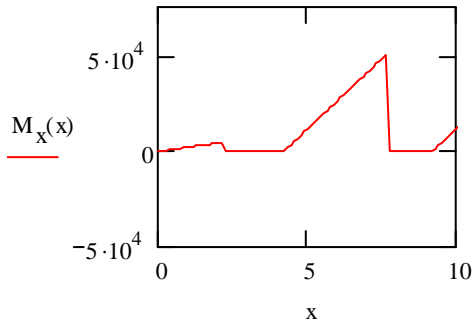

Critical Section

$$M_x(7.74999\text{in}) = 135.1\text{ lbf}\cdot\text{in}$$

Simplified Stress for Round Cross-Section

$$\sigma_{X\text{max}} := \frac{32M_x(7.74999\text{in})}{\pi \cdot D_s^3} \quad \sigma_{X\text{max}} = 3.262 \times 10^3 \text{ psi}$$

Given

$$0 = R_{1z} \cdot S(b', b') \cdot (b' - b')^0 + R_{2z} \cdot S(b', d') \cdot (b' - d')^0 - T_{3z} \cdot S(b', L) \cdot (b' - L)^0$$

$$0 = R_{1z} \cdot S(d', b') \cdot (d' - b')^0 + R_{2z} \cdot S(d', d') \cdot (d' - d')^0 - T_{3z} \cdot S(d', L) \cdot (d' - L)^0$$

$$\begin{pmatrix} R_{1z} \\ R_{2z} \end{pmatrix} := \text{Find}(R_{1z}, R_{2z})$$

Reaction Forces

$$R_{1z} = 0\text{ lbf}$$

$$R_{2z} = 48.296\text{ lbf}$$

Given

$$0 = R_{1z} \cdot S(b', b') \cdot (b' - b')^1 + M_{1y} \cdot S(b', b') \cdot (b' - b')^0 + R_{2z} \cdot S(b', d') \cdot (b' - d')^1 \dots$$

$$+ M_{2y} \cdot S(b', d') \cdot (b' - d')^0 - T_{3z} \cdot S(b', L) \cdot (b' - L)^1$$

$$0 = R_{1z} \cdot S(d', b') \cdot (d' - b')^1 + M_{1y} \cdot S(d', b') \cdot (d' - b')^0 + R_{2z} \cdot S(d', d') \cdot (d' - d')^1 \dots$$

$$+ M_{2y} \cdot S(d', d') \cdot (d' - d')^0 - T_{3z} \cdot S(d', L) \cdot (d' - L)^1$$

$$\begin{pmatrix} M_{1y} \\ M_{2y} \end{pmatrix} := \text{Find}(M_{1y}, M_{2y})$$

Reaction Moments

$$M_{1y} = -1.572 \times 10^{-14} \text{ lbf}\cdot\text{in} \quad M_{2y} = 108.667\text{ lbf}\cdot\text{in}$$

$$M_y(x) := R_{1y} \cdot S(x, b') \cdot (x - b')^1 + M_{1y} \cdot S(x, b') \cdot (x - b')^0 + R_{2y} \cdot S(x, d') \cdot (x - d')^1 \dots$$

$$+ M_{2y} \cdot S(x, d') \cdot (x - d')^0 - T_{3y} \cdot S(x, L) \cdot (x - L)^1$$

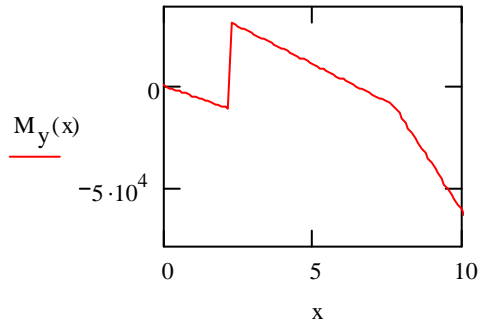

Critical Section

$$M_y(10\text{in}) = -153.635\text{lb}\cdot\text{in}$$

Simplified Stress for Round Cross-Section

$$\sigma_{Y\text{max}} := \frac{32M_y(10\text{in})}{\pi \cdot D_s^3} \quad \sigma_{Y\text{max}} = -3.709 \times 10^3 \text{ psi}$$

Von Mises Stress

$$\sigma' := \sqrt{\sigma_{X\text{max}}^2 + \sigma_{Y\text{max}}^2 - \sigma_{X\text{max}} \cdot \sigma_{Y\text{max}}}$$

$$\sigma' = 6.041 \times 10^3 \text{ psi}$$

Safety Factor

$$N := \frac{S_{\text{ut}}}{\sigma'} \quad N = 2.979$$