

March 2016

# The Snow Rake: Developing a Device to Remove Snow from Multiple Story Roofs

Grant Michael Brining  
*Worcester Polytechnic Institute*

Mark Samuel Chakuroff  
*Worcester Polytechnic Institute*

Thomas James Stanovich  
*Worcester Polytechnic Institute*

Zachary Joseph Charland  
*Worcester Polytechnic Institute*

Follow this and additional works at: <https://digitalcommons.wpi.edu/mqp-all>

---

## Repository Citation

Brining, G. M., Chakuroff, M. S., Stanovich, T. J., & Charland, Z. J. (2016). *The Snow Rake: Developing a Device to Remove Snow from Multiple Story Roofs*. Retrieved from <https://digitalcommons.wpi.edu/mqp-all/861>

This Unrestricted is brought to you for free and open access by the Major Qualifying Projects at Digital WPI. It has been accepted for inclusion in Major Qualifying Projects (All Years) by an authorized administrator of Digital WPI. For more information, please contact [digitalwpi@wpi.edu](mailto:digitalwpi@wpi.edu).

# The Snow Rake:

Developing a Device to Remove Snow from Multiple Story Roofs

PROJECT REPORT

SUBMITTED IN PARTIAL COMPLETION OF THE REQUIREMENTS FOR A  
MECHANICAL ENGINEERING MAJOR QUALIFYING PROJECT

WORCESTER POLYTECHNIC INSTITUTE

Submitted to:

Project Advisor: John Sullivan

Submitted by:

Grant Brining

Mark Chakuroff

Zachary Charland

Thomas Stanovich

Date: March 9, 2016

Project No: JMS-1604



# WPI

# Abstract

Every year, heavy snowfall around the country puts the structural integrity of residential homes at risk. While single story homes can be cleared of this load easily, it is a daunting task to climb on the roof to remove snow from a multiple-story home. The goal of project was to design, fabricate, and test a snow removal system that would dramatically increase worker safety by allowing a contracting team to clear snow from a second story roof without ever even getting on a ladder.

The first prototype used a “wedge” ramp that rode up the roof. A series of ropes maneuvered the roof device, which positioned the snow onto a plastic tarp, allowing it to slide off the roof. Unfortunately, the designed prototype illuminated the complex control of the ropes. The rope deployment created significant constraints to avoid damage to roofing tiles. An alternative prototype was constructed that ameliorated the concerns with the first design. Preliminary testing with this design proved it to be effective; however, additional testing will be needed before it could be fully vetted.

# Acknowledgments

We would like to extend our sincerest thanks to the following people and intuitions, without whom this project would not have been possible:

*Howard Products, Worcester, MA:* We would like to thank Howard Products for assisting us with the fabrication of our prototypes. They were gracious enough to lend us their professional expertise and equipment to bend out 1/8" aluminum sheeting free of charge. Without them, our prototype would not have been nearly as professional.

*Worcester Polytechnic Institute:* We would like to thank WPI for not only providing our team with the engineering background and knowledge to attempt this project, but the funding to do so as well.

*Professor John Sullivan, WPI:* We would like to especially thank Professor Sullivan for his assistance, advice, and guidance throughout the course of our project. His input, gained from years of experienced, helped us to elevate our designs to a higher level of effectiveness and saved us countless hours of trial and error.

# Table of Contents

Abstract.....	i
Acknowledgments.....	ii
1. Introduction.....	1
1.1 Project Goals.....	1
1.2 Project Constraints and Requirements .....	2
2. Background Research .....	2
2.1 New England Snowfall Statistics.....	3
2.1.1 Snow Density.....	3
2.2 The Cost of Roof Damage .....	4
2.2.1 Financial Cost .....	4
2.2.2 Human Cost .....	5
2.3 Roof Design .....	6
2.3.1 Construction Techniques .....	6
2.3.2 Local Roof Survey.....	9
2.4 Current Snow Clearing Methods .....	11
2.5 Ergonomic Research.....	13
3. Multiple-Story Clearing Designs .....	13
3.1 Design Process.....	13
3.2 Top Designs .....	14
3.2.1 “Lawn Mower” Design” .....	14
3.2.2 “Flower Design” .....	15
3.2.3 “Wedge” Design .....	16
3.2.4 Attachment Methods.....	16
3.3 Choosing the “Best” Design .....	17
3.4 Design Specifications.....	19
3.4.1 Rake Design.....	19
3.4.2 Driving Mechanism Design.....	21
3.4.3 Roof Ridge Protection ("Millipede").....	22

3.4.4 Rope Launching Mechanism .....	23
3.5 Using the Roof Clearing System.....	23
3.6 Structural Analyses .....	25
3.6.1 Rake Design Simulations .....	25
3.6.2 Driving Mechanism Simulations .....	29
3.6.3 Roof Protector Simulations.....	30
4. Constructing the Roof Rake.....	30
4.1 Roof Ridge Protector Construction.....	31
4.1.1 First Millipede Prototype .....	31
4.1.2 Second Millipede Prototype.....	32
4.1.3 Final Millipede Design .....	32
4.2 Wedge Construction.....	33
4.2.1 Bending the Sheet Aluminum.....	33
4.2.1 Creating the Frame.....	34
4.2.3 Constructing the Breaker Bars .....	35
4.2.4 Building the Tarp Roller .....	35
4.3 Winching Platform Construction .....	36
5. Preliminary Testing.....	37
5.1 Testing Locations.....	38
5.1.1 Tilted desk.....	38
5.1.2 Metal HVAC Guard.....	39
6. Testing the Snow Removal System on a Roof.....	41
6.1 Testing Location .....	41
6.2 Testing Procedure .....	41
6.3 Testing Results.....	42
6.3.1 Wedge Analysis .....	42
6.3.2 “Millipede” Analysis .....	43
6.3.3 Platform Analysis.....	47
6.3.4 Rope Analysis .....	48
6.4 Testing Conclusions.....	49
7. Alternative Design .....	51

7.1 The Tarp Roller.....	51
7.2. Testing the Tarp Roller .....	52
7.3 The Improved Tarp Roller .....	54
8. Conclusions.....	55
9. Works Cited .....	57
10. Appendix.....	58
10.1 Roof Survey Results .....	58
10.2 Drawings.....	60
10.3 Clearing Diagrams .....	61
10.4 Construction Bill of Materials .....	63

# 1. Introduction

During the winter of 2014-2015, there were 270 roof collapses due to snow in Massachusetts.<sup>1</sup> Unfortunately, the only surefire way to prevent these collapses was to remove excessive amounts of snow. Although necessary, roof clearing is an expensive, time consuming, and frequently a hazardous



*Figure 1: Clearing a Cape Style Home*

task. The snow, ice, wind, and extreme temperatures brought by winter, in combination with the height of an average roof, leads OSHA to strongly caution both homeowners and contractors from getting on a roof to clear it. Unfortunately, while there are devices that can clear snow off of a first story roof, multiple-story structures lack a proven technology or strategy. Recognizing this deficiency, we designed, constructed, and tested devices that allow an operator to safely clear snow from second story roofs while remaining on the ground.

## 1.1 Project Goals

The two primary goals that dominated the design were user safety and device effectiveness, respectively. While the desire to improve user safety was the genesis for this project, constructing an effective, economical device was also critical for success.

---

<sup>1</sup> Massachusetts Emergency Management Agency. p.19



The device's effectiveness was measured in three ways: cost effectiveness; snow clearing efficiency, and a low potential for roof damage.

## 1.2 Project Constraints and Requirements

Before a roof-clearing device could be designed, it was necessary to establish a list of safety constraints and basic functional requirements. Although some of these requirements may limited the types of houses that could be cleared, it was most important to be able to clear a roof safely and effectively. The following list of project constraints and functional requirements were adhered to when designing, constructing, and testing the device.

- Can be operated by 2-3 people from ground level
- Users do not need to get on roof
- Need at least 20' separation between adjacent homes
- Approximate safety factor of 2 for the designed components
- Able to clear a minimum 18" width of snow in one pass
- Will not clear ice dams
- Will work with snow up to half the density of water (500 kg/m<sup>3</sup>)
- Designed primarily for professional contractors
- Will fit in the bed of a standard pick-up truck for transport
- Limit weight of rake to 20 lbs and driving platform to 50 lbs for safe lifting
- Less than \$600 MSRP
- Should not infringe on existing patents

## 2. Background Research

Throughout the early phases of the design process, various aspects of the project were researched, including information on snow, roofs, and current snow rake designs.

## 2.1 New England Snowfall Statistics

Annual snowfall records for the United States frequently identify cities located in Alaska and the Rocky Mountains on top of the charts. Although the Northeastern US does not get the most snow, heavy snowstorms in Northeast, especially New England, typically cause more social disruption due to the population density. Snowstorms create such a significant disruption that the Northeast Snowfall Impact Scale (NESIS), a specific scale measuring the impact of snowstorms in the Northeast, was created. This scale works much like the Fujita scale for tornados. Since 1967, there have been 57 “high-impact” storms in the Northeast.<sup>2</sup>

Massachusetts, in particular, frequently exceeds three feet of snow each winter. Using NOAA Climate Normals data collected between 1981 and 2010, the average annual snowfall in Boston, MA is 43.8 inches and 64.1 inches in Worcester, MA.<sup>3</sup> While these averages do give a good indication of the amount of snow that central New England might get any given year, they do not tell the full story. During the winter of 2015, Worcester was one of the snowiest cities in the country with a grand total of 116.8 inches.<sup>4</sup>

### 2.1.1 Snow Density

The amount of snow a region gets does have a significant impact on the structural loading of a roof; however, the most important factor to be considered is the density of the snow. The more dense the snow, the greater the load on the roof, and the greater the chance of roof collapse. Unfortunately, the density of snow is not very consistent; a new

---

<sup>2</sup> "Regional Snowfall Index (RSI)." *National Centers for Environmental Information*.

<sup>3</sup> "Average Annual Snowfall in Massachusetts." *Current Results*.

<sup>4</sup> Cox, John Woodrow. "Top 10 Snowiest U.S. Cities This Winter."

coating of fluffy snow is about 8% of the density of water. After the snow falls, its density can increase up to 40% of water due to a variety of factors including wind, gravitational settling, and melting. It is important to note that the average density of snow in New England is higher than other areas of the country due to less extreme temperatures. See Table 1 for snow density data.<sup>5</sup>

*Table 1: Common Snow Densities*

Example	Water Content		
	Percent	g/cm <sup>3</sup>	kg/m <sup>3</sup>
Fluffy new fallen snow	8	0.08	80
Slightly metamorphosed snow	15	0.15	150
Depth hoar	20	0.20	200
Settled snow	30	0.30	300
Ice lens in snowpack	45	0.45	450
New glacial ice	70	0.70	700
Old glacial ice	90	0.90	900
Pure water	100	1.00	1000

g = gram, cm<sup>3</sup> = cubic centimeter, kg = kilogram (2.2 lbs), m<sup>2</sup> = square meter

## 2.2 The Cost of Roof Damage

### 2.2.1 Financial Cost

Winter can be an extremely expensive time for homeowners, especially a New England winter with heavy snowfall. During periods of heavy snowfall, removing snow from roofs becomes mandatory, lest the homeowner risk structural damage to their home or a complete collapse of the roof. Unfortunately, snow removal can be very expensive. The average price to clear a roof is about \$75 per man-hour; that puts the total cost to

<sup>5</sup> Halfpenny, James C. Winter: An Ecological Handbook. p. 52

clear an average residential roof between \$750 to \$2000.<sup>6</sup> Depending on the severity of the winter, a homeowner may need to clear their roof more than once. Desperate homeowners may also fall victim to snow removal scams. In the winter of 2015, Boston police warned residents to be wary of contractors giving low initial estimates and then billing clients for much more than the original estimate. Although these scams were more common among elderly homeowners, they can make winter an even more expensive proposition.<sup>7</sup>

Although many homeowners bite the bullet and pay to have their roofs cleared, or they do it themselves and risk injury, many others have to pay for the damages caused by too much snow. The average cost to repair a small hole in an asphalt roof is \$575 while it costs an average of \$6000 to completely shingle an average roof.<sup>8</sup> If a homeowner were to experience a roof collapse, the cost can quickly jump to tens of thousands of dollars. During a two-week span in February of 2015, there were 131 roof collapses in Massachusetts.<sup>9</sup> According to the Massachusetts Emergency Management Agency, there was a total of 270 roof collapses during the winter of 2015, 132 of which were residential structures.<sup>10</sup>

### 2.2.2 Human Cost

In addition to structural damage, injury or even death, is also a potential cost of snow removal. During the winter of 2015, three men were killed in the period of ten days

---

<sup>6</sup> Hamilton, Anne. "What's A Fair Price To Clear Off A Roof Of Ice And Snow?"

<sup>7</sup> "Police: Watch Out For Roof Snow Removal Scams."

<sup>8</sup> "Will Your Roof Cost You Thousands This Winter."

<sup>9</sup> Mcatte, Paige. "Snow-Covered Roofs Causing Injuries, Deaths in Massachusetts."

<sup>10</sup> Massachusetts Emergency Management Agency. p.19

while clearing roofs in Portland, ME.<sup>11</sup> In Canton, MA, two men were killed while clearing roofs.<sup>12</sup> Although these two deaths were the only roof clearing related deaths in Massachusetts for the winter of 2015, there were 1320 people who received blunt force trauma injuries while clearing snow.<sup>13</sup> Although this figure does not specify how many were injured while clearing roofs, it is reasonable to assume at least a small percentage were.

Death and injury due to snow clearing and roof collapse does not just occur during periods of extremely heavy snowfall, like the winter of 2015. During the winter of 2014, a relatively light winter in comparison to 2015, at least one woman in Massachusetts was killed due to a roof collapse.<sup>14</sup>

## 2.3 Roof Design

In order to get a better understanding of what might cause damage to a shingled roof, construction techniques were researched. Local roofs were also surveyed for design characteristics.

### 2.3.1 Construction Techniques

There are four layers of roof construction; these layers can be seen in Figure 2.

---

<sup>11</sup> Hoey, Dennis. "Three Deaths in Portland Linked to Snow Removal."

<sup>12</sup> Pattani, Aneri. "2 Die in Fatal Falls While Clearing Snow from Roofs in Canton."

<sup>13</sup> Massachusetts Emergency Management Agency p.17

<sup>14</sup> Germano, Beth. "Woman Killed In Weymouth Roof Collapse."

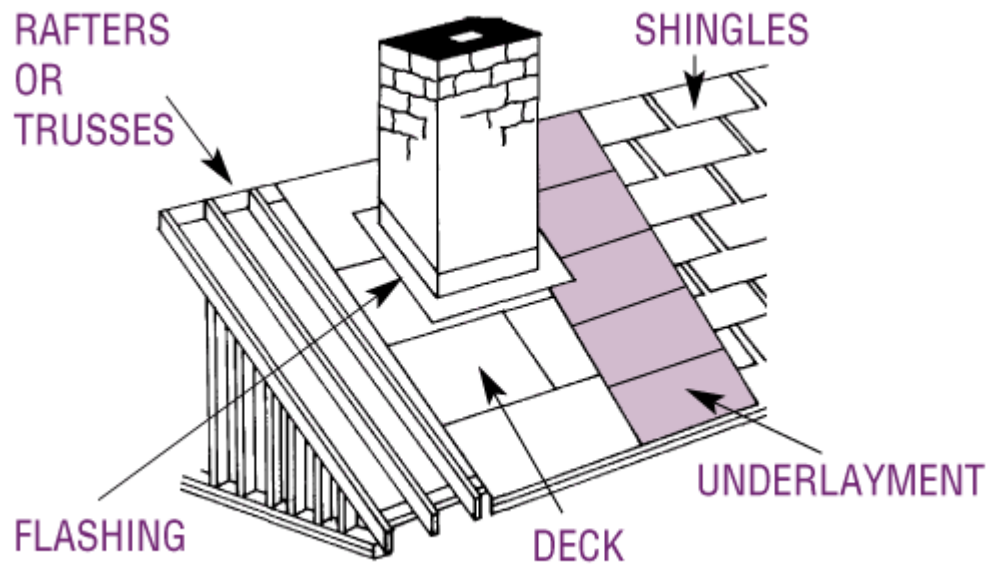

*Figure 2: Construction of a roof*

The underlayment (Please note: this is the technical name for this layer of roofing. This does not refer to any underlying support structure of the roof). This layer is used to seal the roof to mitigate water intrusion. The underlayment is laid over the structural layer, and is most commonly a layer of black paper. Often, this layer will include a membrane as well as a simple paper covering.

The third layer is not a consistent layer. Flashing is a partial layer, one that is laid only in water collection areas. This layer is most commonly metal sheet, and they are placed so that they collect and/or disperse water to avoid pooling.

The shingles form the outermost layer of the roof. They are the immediate protection between the house and the elements. Shingles are layered to provide optimal

protection. As the roof clearing system will deal with the outermost layer (the shingles), this is the area of greatest concern for the design.

The final layer is trim. This is used exclusively on the ridges and seams of the roof. It is also typically composed of shingles. However, they are laid in a slightly different manner, one that protects the desired ridge or seam<sup>15</sup>.

Asphalt shingles are the dominant roofing material in the United States, especially the Northeast. They are laid in an overlapping manner down the roof, seen in Figure 3. Also see Figure 3 for an example of damaged shingle.



*Figure 3: Roof Damage on an Asphalt Shingle*

Asphalt tiles are a popular choice because they are durable, cheap, and simple to install. It is curious though, and should be noted that in other parts of the world asphalt roofing tiles are not commonly used or in downright violation of building codes.

There are four other common building materials in the United States. Of these four, three are tiles, and utilize the same basic design as asphalt shingles with respect to the overlapping method. They are slate, wood tiles, ceramic tiles, and metal. Modern metal roofs utilize an overlapping method, similar to shingles. However, older metal roofs, especially those in the south still use a corrugated metal design. This means that for

---

<sup>15</sup> Madsen, Jana. "The Top 10 Most Common Roof Problems"

the purpose of clearing snow from a roof, the clearing device should move from peak of roof to lowest point, or have some method of clearing the gap<sup>16</sup>.

There are several causes of irregularities that may cause the roof to be damaged before a snow-clearing mechanism could be deployed. The most common are poor installation/workmanship, expansion due to moisture, punctures and other weather damage, improper repairs, shrinking shingles, and blistering<sup>17</sup>.

All of the above could cause potential problems for a roof clearing system; the snow removal system was carefully designed to not damage the roof, and not to further any existing damage, which is a more pressing problem, as shingles may be partially separated from the roof's normal shingle pattern when damaged.

Massachusetts code requires roofs to sustain 50 pounds per square inch of loading. However, many structures built decades ago are "grandfathered" into the code, meaning that they do not have to be updated to be kept in compliance with current code. As such, actual conditions will vary with the individual building.

### 2.3.2 Local Roof Survey

In New England, there are three primary types of single-family residential homes: the single story ranch house, the Cape house (Figure 4), and the "traditional" second story



*Figure 4: A Common Cape Style House*

---

<sup>16</sup> Monarch Roofing. "The Four Most Common Residential Roofing Materials."

<sup>17</sup> "Roofing Component Basics."



house (Figure 5). Additionally, each home may have a combination of different architectural features. In order for our snow removal device to be successful, it had to be compatible with a reasonable percentage of home types and design variations. To assess the potential effectiveness of a snow removal device, a survey of local roofs was conducted using Google Street View. Data was gathered using the following method:



*Figure 5: A Common "Traditional" Two Story*

First, four towns in Massachusetts were selected; because a design constraint was that homes should be more than 20 feet apart for safety reasons, cities with a high population density were overlooked. The towns of Grafton, Holden, Shrewsbury, and Westford were chosen.

For each individual town, a large residential road was chosen, provided it was compatible with Google Street View, and data was recorded on 50 homes. Although the rake could be used on first story homes, and possibly taller third stories, only two story residential buildings were surveyed.

Once a building was determined to be a two story residential structure, its type was recorded. A Cape house was defined as a second story home with a roof starting on or near the first floor. A "Two Story" was defined as a house with the roof starting on or near the second floor. Thirdly, an "Other" category was made for homes with odd architecture (pointed or flat roofs, odd roof angles, or features that could severely inhibit a roof rake, such as skylights).

Finally, after the type was recorded, any features the roof might have, such as dormers, an angled junction in the roof, valleys, chimneys, or other obstructive features

were recorded. A total of 200 homes were surveyed. The results of the survey can be found in Appendix 6.1.

## 2.4 Current Snow Clearing Methods

There are currently only a few different methods of clearing snow off a roof. The traditional method of shoveling is the most commonly used, but it can also cause a tremendous amount of damage to the roof. The use of metal or plastic shovels along with the damage done by walking on an asphalt shingle roof can severely decrease the life expectancy of a roof. The friction between the objects and the shingles causes the

shingles to deteriorate, peel up, or even break off. Shoveling the roof is extremely dangerous and can be avoided by using a snow rake. The snow, ice, and weather conditions create many risks for the workers on the roof, as seen in figure 6.



*Figure 6: Traditional Snow Clearing Method*

### 2.4.1 Traditional Snow Rakes

Snow rakes are commercially available for homeowner and contractor use. These rakes are limited to clearing single story roofs due to the long pole attachment that is required for the rake. The traditional rake design is a 10' - 12' fiberglass pole with a plow attachment on the end. The plow acts as the raking mechanism as the user pulls it down the roof, clearing the snow. The plow is typically 6" tall and 1' - 2' wide. The size and length of the rake severely limits the amount of snow removed per pass on the roof.

Traditional snow rakes can also damage the roof if they do not have wheels or are used

incorrectly. The dragging of the plow on the shingles can damage them and decrease their life expectancy. Many rakes are now equipped with



*Figure 7: True Temper Roof Rake*

small roller wheels on the bottom of the plow to gain clearance and roll over the shingles. An example of a traditional snow rake can be seen in Figure 7.

#### 2.4.2 Advanced Snow Rakes

Advanced snow rakes have a different design and function than traditional snow rakes. Advanced snow rakes have a cutter head that disrupts the snow and the snow slides off of the roof onto a low-friction plastic sheet that trails the cutter head. These rakes remove the snow by using a pushing motion from the user rather than the pulling motion used with a traditional snow rake. The pushing motion allows the cutter head to break through the snow and the plastic sheet is dragged behind it.



*Figure 8: Advanced Roof Rake Clearing Snow*

The disadvantages of advanced snow rakes are similar to those of the traditional snow rakes; the length of the pole attached to the cutter head limits the user's reach. Advanced roof rakes have wheels on them to give clearance over the asphalt shingles. In general, advanced roof rakes perform better and cause less damage to roofs than traditional roof rakes. An example of an advanced snow rake can be seen in Figure 8.

## 2.5 Ergonomic Research

Ergonomic data was researched to determine the ideal method for an end user to operate the roof rake design; the focus of this research was the effects of excessive force on operator wellbeing. The definition of "excessive force will vary from person to person; however, an excessive force can be generally described as one that requires either an abnormal ergonomic position and/or application of the force for an abnormal length of time.<sup>18</sup> According to ergonomic experts, all efforts should be made to reduce applications of "excessive force" in the workplace and in everyday life. Devices which give the user a mechanical advantage, such as levers, slides, conveyors, and wheels, should be used whenever possible to help minimize the exertion of "excessive force."<sup>19</sup>

## 3. Multiple-Story Clearing Designs

After research was concluded, it was clear that there was no system on the market that could safely clear multiple story roofs with its operator on the ground. Considering that many New England homes feature first and second story roofs, it was essential that the final snow rake design could tackle these multi-story homes. After a design for the entire system was chosen, simulations were conducted to ensure that the design would hold up the rigors of snow removal.

### 3.1 Design Process

The design process started with independent brainstorming. Once each member of the four-man team had created an independent design, the group reconvened. Designs

---

<sup>18</sup>MacLeod, Dan. *The Rules of Work: A Practical Engineering Guide to Ergonomics*. p.21

<sup>19</sup>*ibid.* p.26

were then discussed and eliminated based on criteria, such as feasibility, ease of use, and safety. A decision matrix was used to allow for judgment. Designs with the highest scores were continued. This matrix can be seen in Table 2 in section 3.3.

Once the basic for the final design was selected, the group again brainstormed concepts for this design. New ideas were then added based on group decision, and with a decision matrix.

## 3.2 Top Designs

The following three designs were the top contenders in the design process.

### 3.2.1 “Lawn Mower” Design”

See Figure 9 for early concept drawings of the “Lawn Mower” design. This design mimics a push reel mower. The swirling wires are intended to cut through snow, and would also be used to break up any chunks of ice found in the snow.

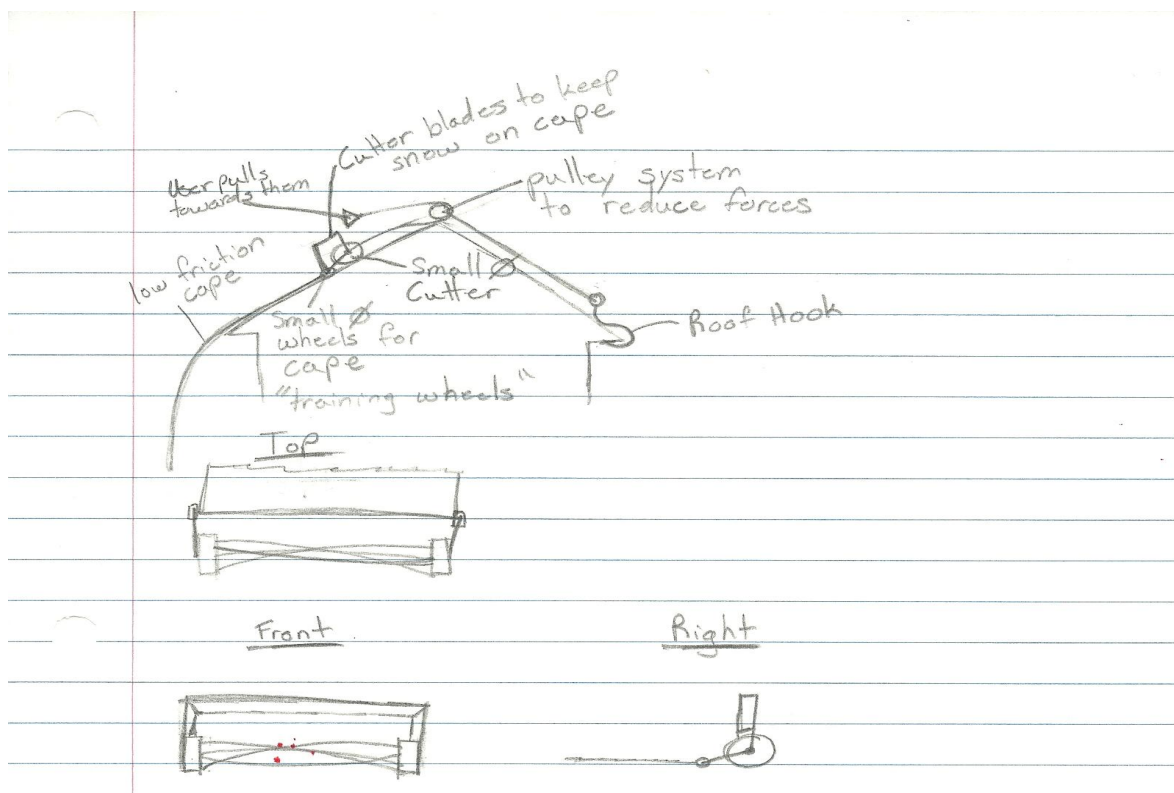

Figure 9: Early Conception Sketches for the "Lawn Mower" Design

As seen in Figure 10, the idea of swirling wire blades later changed to tines, closer to those found in a rototiller than in a lawn mower. This would eliminate the need for a speed differential between the wheel and the reel.

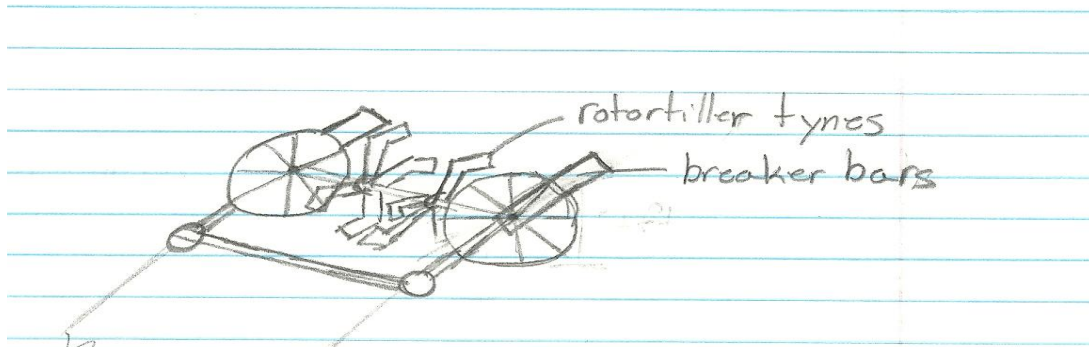

Figure 10: Second Rendition of the "Mower" Design

### 3.2.2 "Flower Design"

This design was created later in the design process, while working on the "wedge" design. The idea behind the "flower" is that it could be pulled up one side of the roof, and then after it reached the apex of the roof, would expand, much like an umbrella, and catch the snow. The user would then pull it to the ground, bringing the captured snow with it. Although this design would allow the user to clear more roof locations, it was abandoned due to concerns over roof damage. See Figure 11 for a CAD model of the "flower".

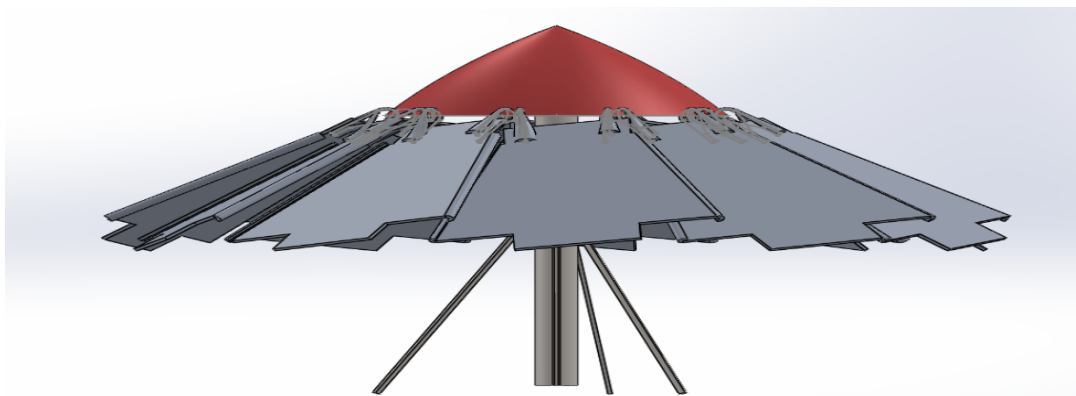

Figure 11: CAD Model of the "Flower" Design

### 3.2.3 “Wedge” Design

The “wedge” design consists of a wedge shape that would be driven under the snow to push snow onto a plastic sheet that will carry the snow down the roof for collection. The plastic sheet is

the key component of this design.

After watching video clips of the

“Avalanche” snow rake, it was

clear that the plastic tarp was an

effective method for removing

snow from roofs; therefore, it

was a desirable feature to include

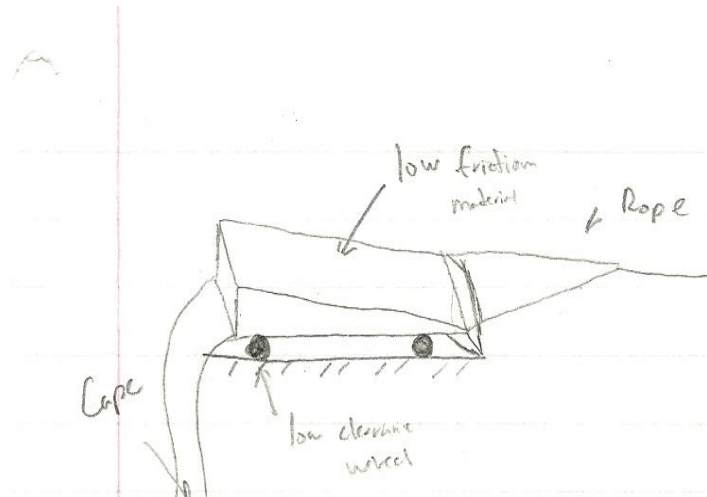

Figure 12: Early Conception Sketches of the Wedge Design

in at least one design. The “wedge” would be pulled by means of rope that was attached to the front axle. This attachment attempted to keep the “wedge” grounded to the roof as much as possible, for the best clearing. Originally, the “wedge” had some design differences, such as the lack of breaker bars, and it would be pulled from the axle directly. See Figure 12 for concept drawings of the wedge.

### 3.2.4 Attachment Methods

Early in the conceptualization process, the idea of attaching a hook under the eave of the roof was explored. This would allow for a base to attach a pulley, or other mechanism to support the main snow-clearing device. The competing design used a ground-based platform that would winch the rake into place.

### 3.3 Choosing the “Best” Design

Once the field was narrowed down to the top three designs, it was necessary to choose a design that would continue to the construction phase. In order to determine which idea might have the most potential, a weighted decision matrix was constructed. It was decided that safety was the most important concern, followed by ease of use, minimal roof damage, and clearing ability. All other design concerns were considered equal. This matrix can be seen in Table 2.

*Table 2: Rake Design Decision Matrix*

	<b>Multiplier/ Weight</b>	<b>Design 1 - "Lawn Mower"</b>	<b>Design 2 - "Flower"</b>	<b>Design 3 - "Wedge"</b>
Safety	5	3	2	4
Ease of Use	4	2	2	3
Weight	3	1	4	2
Portability	3	1	4	1
Manufacturability	3	2	1	5
Durability	3	4	3	4.5
Cost	3	2.5	4	3
Limit Roof Damage	4	3	2	3
Clearing Ability	4	2	3	2
<b>Total</b>		<b>74.5</b>	<b>89</b>	<b>98.5</b>

Although it was clear that designs two and three were superior to design one, it was more difficult to pick an overall winner. Both the “Flower” and “Wedge” designs have their strengths and weaknesses; however, the “Wedge” design was eventually selected for two reasons: manufacturability and clearing ease of use. The “Flower” design would have required more advanced construction techniques, such as welding. In addition, this design would need more than one pass to clear a single section of the roof, increasing clearing time significantly.



After the “Wedge” rake was selected, the next task was to choose how to actually attach the rake to the roof. As before, a weighted decision matrix was constructed for the two design options. See Table 3 for details.

*Table 3: Decision Matrix for Attachment Method*

	<b>Multiplier/ Weight</b>	<b>Design 1 - Eve Hook</b>	<b>Design 2 - Driving Platform</b>
Safety	5	5	4.5
Mechanical Advantage	4	3	5
Weight	3	4	2.5
Portability	3	4	3
Manufacturability	3	3.5	5
Durability	3	4	5
Cost	3	3	4
Limit Roof Damage	4	4	5
Speed of Clear	3	3	3.5
<b>Total</b>		<b>117.5</b>	<b>131.5</b>

While both options had their merits, the driving platform was selected over the direct roof attachment. The two primary reasons for this were that the driving platform makes it slightly easier to move the wedge side to side and that the winch would provide significant mechanical advantages that direct roof attachment could not. This mechanical advantage will help prevent users from applying “excessive force” while clearing the roof. Another consideration was cost. The power rope was the single most expensive component of the design and attaching the rake to the eve of the roof would require more rope, increasing the cost further.

### 3.4 Design Specifications

Once the preliminary designs for each component were established, each design was fine tuned for performance and detailed CAD models were created using SolidWorks. While these were the designs that were taken into the construction phase, many changes were along the way. These changes are discussed in the construction section.

#### 3.4.1 Rake Design

The rake consists of four major parts: the frame, the top, the sheet roller, and the breaker bars. The full rake design can be seen in Figure 13. The frame of the rake is built around three support pieces, each of which is constructed from 1/2" plywood. Two solid stainless steel axles run through these supports, along with a piece of reinforced

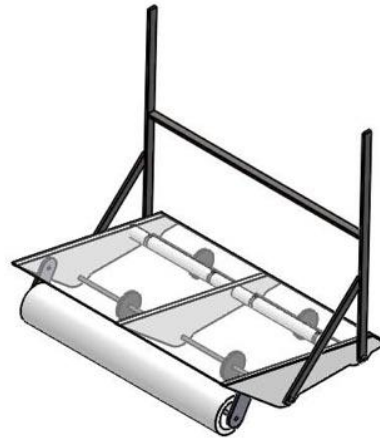

*Figure 13: CAD Model of Final Wedge Rake Design*

PVC tubing. There are four wheels total; two on each axle, and the PVC is used to attach ropes to the rake. A sheet of PVC coated, 1/8" thick, aluminum is attached across the top frame. This PVC coating serves to further reduce friction and allows snow to easily slide off the top of the rake. Please see Appendix 6.1 for rake drawings.

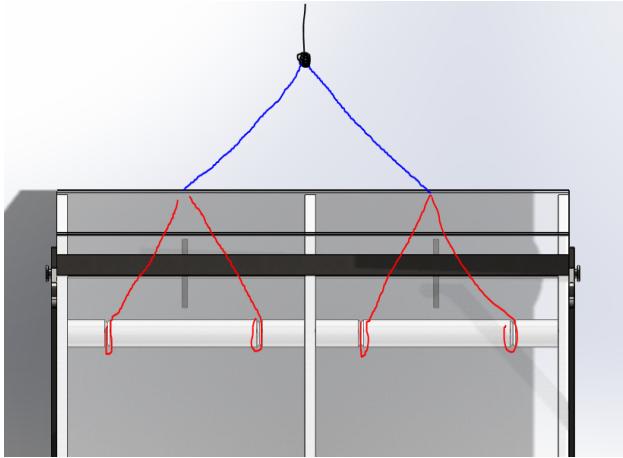

Figure 15: Rope Attachment Layout

Two changes from the original wedge design, the addition of a tarp roller and breaker bars, were added at this time. Attached to the back of the frame is a roller designed to hold a two foot wide tarp with that is 50' long, and 0.16" thick. This tarp was to be rolled out during snow clearing to provide a

low friction surface to aid in snow removal. When not in use the tarp could be stored on the roller, minimizing the device's storage footprint. Finally, a set of breaker bars was added to each side of the frame with support bars on the sides and through the middle. These bars are 1/4" thick and about two feet long and will cut through any surface ice that is on top of the snow. In the original wedge design, the power rope was attached to the front axle of the wedge. In the final design, in order to improve strength, there were ropes attached to the reinforced PVC tube in the frame, see Figure 14. In this figure, the red lines attached directly to the PVC represent two strands of 550 paracord, each of which is capable of holding 550 pounds.

The blue lines represent three strands of 550 paracord each. Finally, the black line represents the power rope, which was connected to the winch. This rope has a tensile strength of

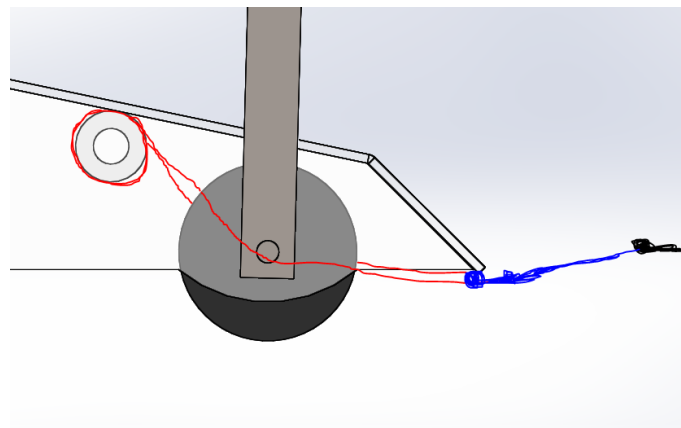
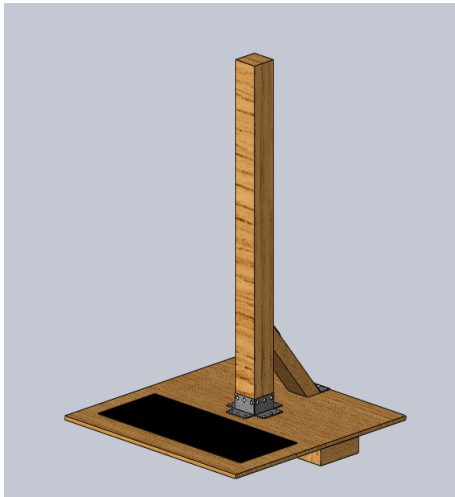

Figure 14: Ropes are Attached under the Wedge for Protection

2000lbs and is 150' long. The first two sets of were to be completely covered in flexible PVC tubing. Because the ropes are attached from the bottom of the rake, as seen in Figure 15, this PVC tubing would prevent the wedge directly contacting the edge of the roof as it is hoisted up. Two more ropes were to be attached to the rear axle, one on each side, to assist the wedge operator in steering the rake up the roof.

### 3.4.2 Driving Mechanism Design



*Figure 16: CAD Model of Winch Platform*

A drawing of the base can be seen in Figure 16. The base was a means to provide a steady pulling force for the wedge. It also provided a means for the operator to comfortably stand out of deep snow. The driving force for the system was created via use of a hand-cranked winch. The winch is pictured below, and was fastened to the side of the post near the top.

The winch selected can be seen in Figure 17, a rope was used instead of a cable. The capacity of this winch is 1200 pounds, and was well beyond the amount of tension that will be in the rope, which would not exceed 200 lbs. As well as a capacity for excess force, the winch also satisfies the length requirements. It was able to hold 100 feet of rope, which was enough for even the largest of houses. It was estimated only 60 feet of rope would be needed for the average house,



*Figure 17: 1200lb Rated Winch*

making this winch more versatile in case more rope was needed.

### 3.4.3 Roof Ridge Protection ("Millipede")

Given the anticipated loads on the rope from both hoisting and operating the wedge, it was necessary to protect the integrity of the roof surfaces that would be subject to abrasion and wear; the ridge of the roof was the area of greatest concern. If the power rope were to contact the ridge of the roof while the rake was being winched up, it could



Figure 19: Petzl "Caterpillar"

act like a band saw and cut through the ridge of the roof, causing significant damage. Unfortunately, there were no commercial products that would protect the ridge of the roof from a load bearing rope; however, the Petzl "Caterpillar" rope guide, designed for rough

terrain, pictured in Figure 19, came close. Using this design as a basis, a product-improved model was created. In addition to having a new set of wheels and a keeper-bar to hold the rope in the guide, this design is seven inches tall, ensuring that the rope will be able to clear the ridge of the roof. See Figure 18 for details. This rope guide was designed to act as a system of four, with two on each side of the roof. They will be held together by 550 paracord, allowing the user to adjust their separation distance as needed. In order to cut costs, this design was to be constructed primarily out of 1/2" plywood and 1/4" hardware. A detailed drawing of this design can be found in the Appendix.

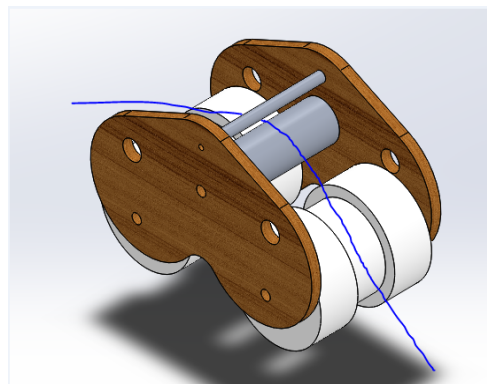

Figure 18: CAD Model of our Roof Protector

### 3.4.4 Rope Launching Mechanism

The wedge design requires a system to launch the ropes over the house in order to attach them to the driving platform. Fortunately, there was a reliable, commercially



*Figure 20: Big Shot Line Launcher*

available system currently on the market: the Big Shot Line Launcher. This launcher, designed to assist in cutting down tree limbs, is made of an 8' fiberglass pole with a slingshot attachment. The model purchased is the Big Shot Launcher Kit with two 4' Marvin Poles which can be seen in Figure 21. The launcher shoots vinyl pouches, which can be easily attached to rope using the clips on the end of each pouch. Due to their construction, these soft pouches would also cause minimal damage to an object inadvertently hit. The vinyl pouches can be seen in Figure 20. Because of



*Figure 21: Big Shot Launching Pouches*

the weight of the power rope, 550 cord will have to be shot over the roof first using the launcher. The power rope will then be attached to the 550 cord and pulled over.

## 3.5 Using the Roof Clearing System

As discussed in previous sections, this roof clearing system has three major components: the wedge rake, the driving platform, and the roof ridge protector. All three of these components would work in conjunction to clear a roof, as seen in Figure 22.

Because the winch operator would not have a line-of-sight to the rake, it was necessary for a third person to act as a coordinator and safety observer.

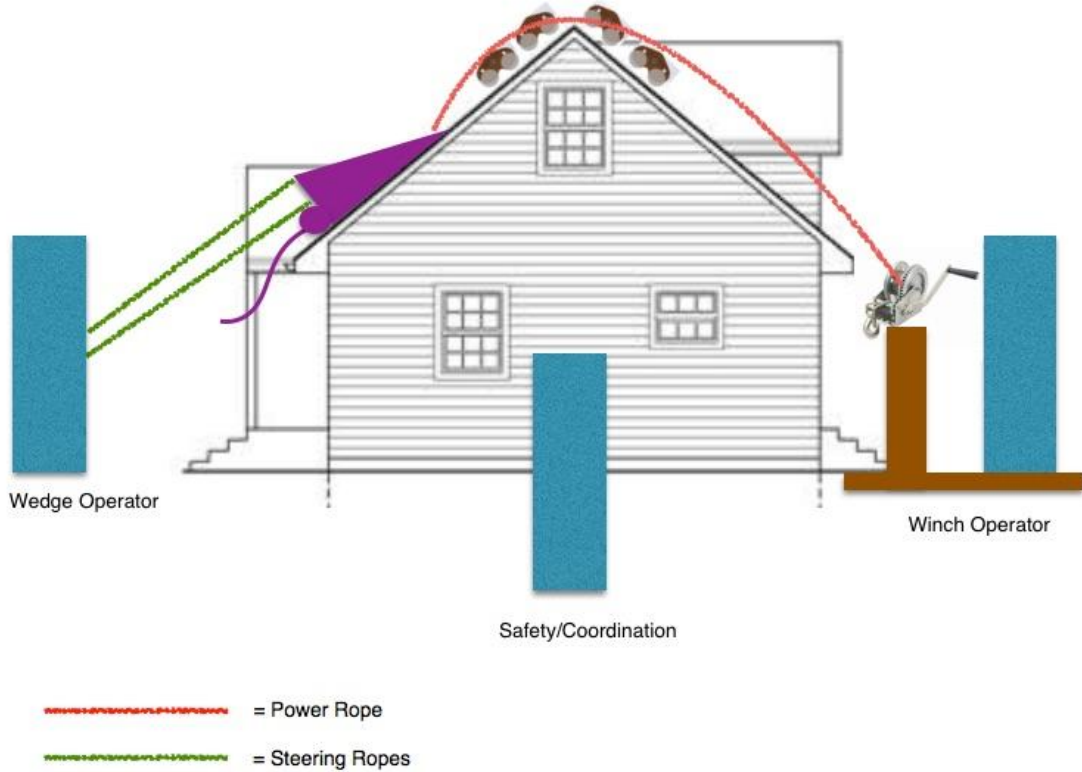

*Figure 23: Roof Clearing System at Work*

Unfortunately, as recorded in the local roof survey, many houses in New England have features such as dormers, angular junctions, or obtrusive chimneys that can get in the way of the roof rake. As a result, some roofs would have sections that are unable to be



*Figure 22: Clearing a Roof with Dormers*

cleared at all; however, in order to prevent ice dams and relieve the snow load from the roof, only about the first six to ten feet of the roof would have to be cleared. In order to clear a roof with dormers, the user would start clearing a section of the roof until a dormer interferes. To move to the next section of the

roof, the user will have to back the rake off the roof, detach the rope from the winch, and relaunch the rope on the other side of the dormer, see Figure 23 for details. A similar procedure was to be used whenever the rake is unable to clear a certain section of the roof. See Appendix for more illustration of clearing limitations.

Based upon the two foot width of the rake, the placement limitations of the rake design, and the results from the local roof survey, it was estimated that the wedge rake design would be able to remove 75% or more snow from about 28% of roofs. See Figure 24 for the rest of the clearing estimates.

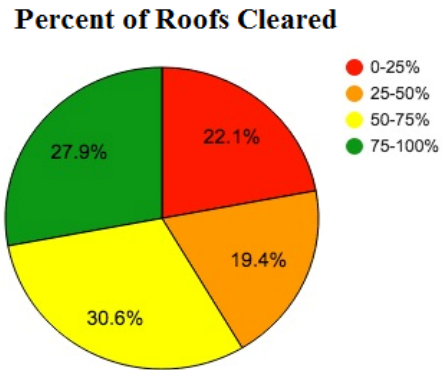

Figure 24: Roof Clearing Estimates Using Wedge Rake

### 3.6 Structural Analyses

Several SolidWords simulations were conducted to test the strength of each component of the roof clearing system to ensure they would hold up under use.

#### 3.6.1 Rake Design Simulations

Figure 25 shows a simulation of the anticipated snow load of 200 lbs acting normal to the aluminum sheet. The supports were assumed rigid to increase calculation speed, and the surface of the

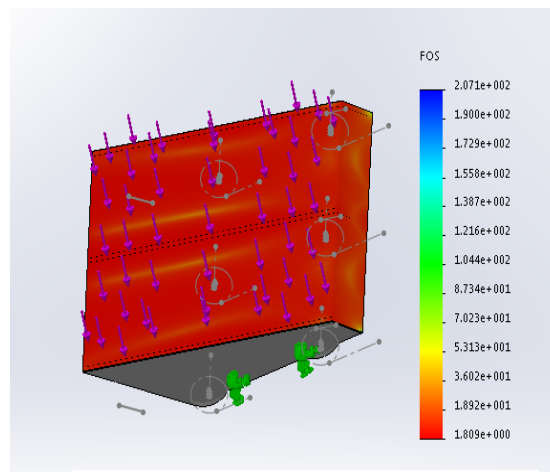

Figure 25: Factor of Safety of Aluminum Sheet



support's axle holes were fixed to simulate the axle holding the load. The lowest factor of safety on the sheet is 1.8. This was a reasonable factor of safety because deforming the sheet could cause the part to no longer operate effectively, but still could not cause injury or loss of life.

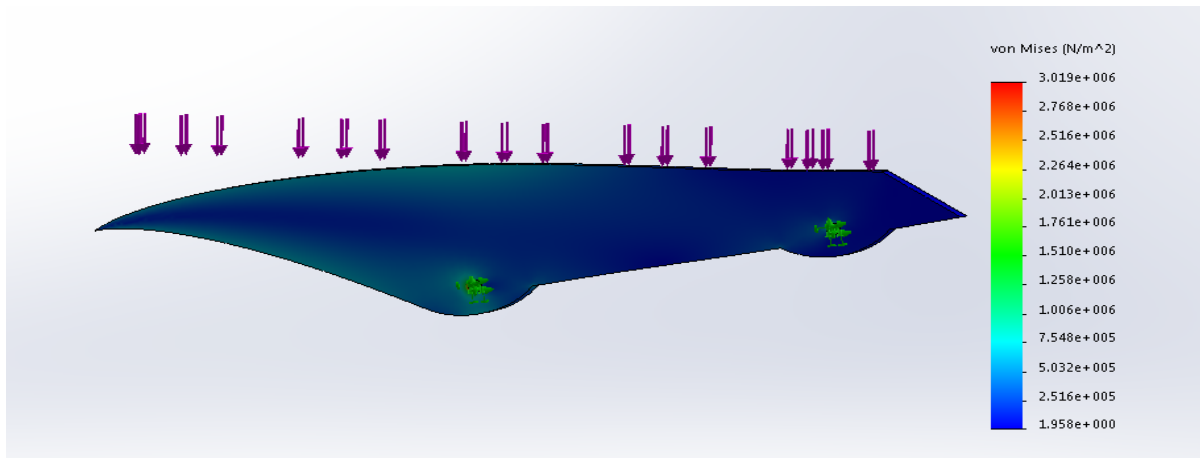

Figure 26: Stress Analysis of Wedge Side Plate

Figure 26 is a simulation showing the anticipated 66.6 lb force acting on one of the support plywood sheets. The surface inside the holes, where contact with the axle was anticipated, have been made 'fixed' in this simulation. The deflection shown is exaggerated 150 times the true anticipated deflection. This exaggerated deflection helps catch errors in the initial constraints. In this case, the deflection direction was appropriate. The assumed ultimate yield of plywood was in the order of 10MPa, but the maximum load shown on this simulation is only 3MPa. Therefore, the part should hold according to these calculations.

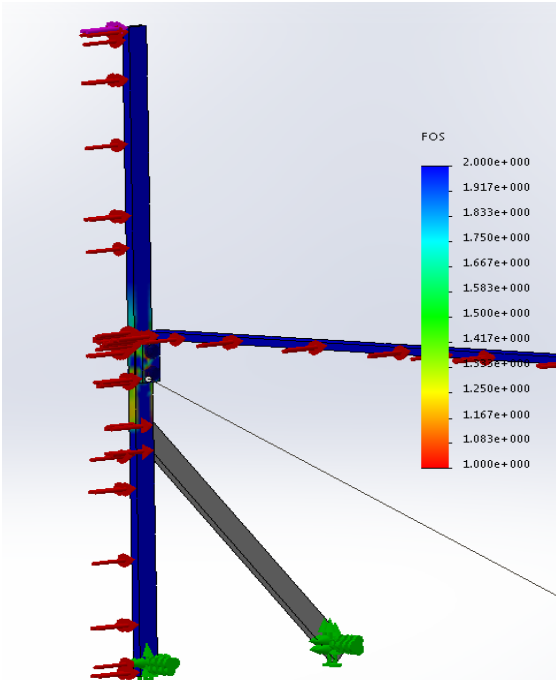

Figure 27 A Simulation of Anticipated Load on the

the only fixed locations were the two hole surfaces along the bottom of the part, where they would be fastened to the axle.

Figure 28 is a close up view of the same simulation. The areas in red indicate a Factor of Safety of 1 or lower. The only three locations of component failure are directly along the bolt holes and at the corner of the rigid support bracket. These were all negligible because the bolts would have washers to distribute the load of the bolts, and the support would

Figure 27 shows the anticipated loading from the snow traveling past the aluminum breaker bars was 2 psi. Additionally, a load of 25 lbs was placed at the top of the bar to simulate forces needed to cut through thin ice patches along the roof. The Factor of Safety along the majority of the bar was well above two, except for the area in and around the bolt locations. The support beam was assumed rigid to increase speed of calculations, while

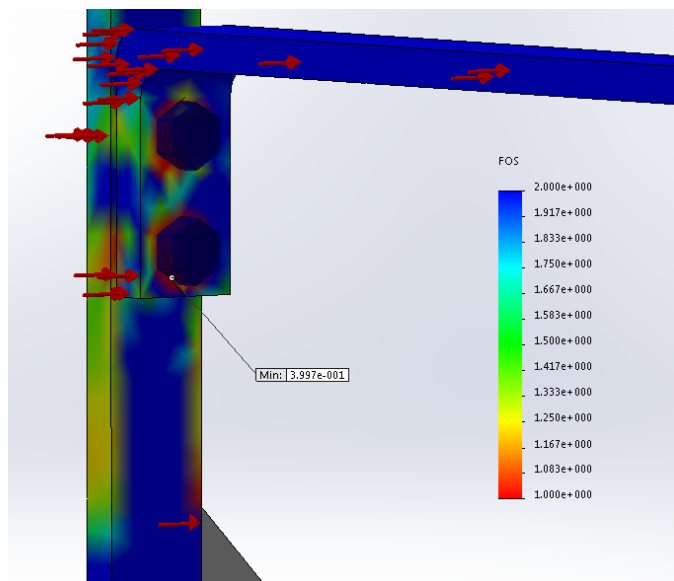

Figure 28: A closer view of the factor of safety across the joint of the breaker bars

not have such a sharp angle. Neither of these was simulated to increase speed of calculations. Disregarding these outliers, this gave the weakest point a factor of safety of approximately 1.3. This was considered acceptable, because the worst-case scenario of the bars exceeding their loads was a bent or possibly broken breaker bar. This did not cause any permanent damage to the operator or the part, as the bars are replaceable.

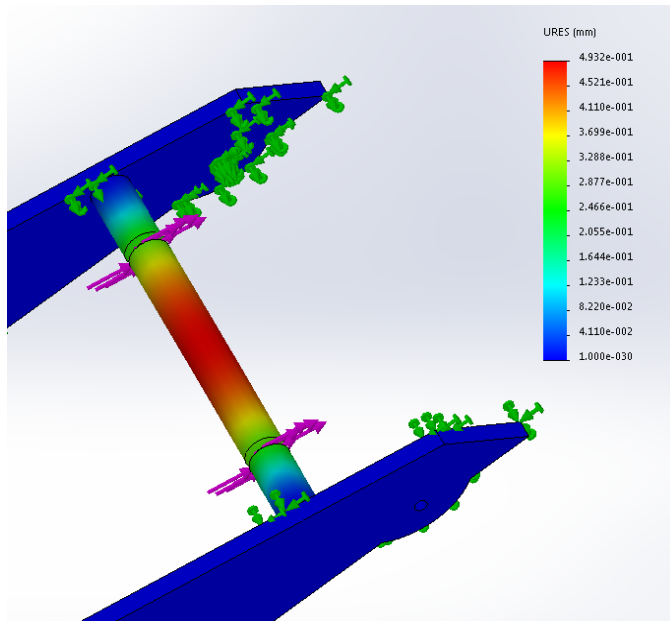

Figure 29: The expected deflection of a piece of rigid PVC tubing.

Figure 29 is a simulation showing the anticipated deflection caused by an 80lb force acting on each of the notches for the rope. The sides of the tube are assumed to be glued in this case and unable to move. Since the part is symmetric, only one side of the beam was shown to increase speed of simulation.

The revolved cuts are also only in place for ease of simulation. The deflection shown is not exaggerated, since the deflection was intuitive and appears accurate. In this case, the deflection direction was appropriate. The maximum deflection was anticipated to be 0.4mm, which for a rigid PVC tubing is not excessive deformation, and it was assumed the tube will be nearly straight for the purposes of loading calculations.

### 3.6.2 Driving Mechanism Simulations

Figure 30 shows a simulation that shows the anticipated driving force of 200 lb acting 45 degrees from the post. Solidworks was unable to provide simulations of von Mises because wood can contain many defects, and has variable grain sizes and fiber density depending on the humidity, temperature, and the individual tree. Young's elastic modulus, although also variable, is closer to constant among each species of tree, and for red oak is generally accepted to be 12 GPa. The deflection shows a material with Young's modulus of 14GPa. The support angle bracket was assumed rigid to allow for faster simulations, while the bottom of the support board was fixed. The maximum deflection of the 4x4 post was 1.5mm. This was negligible, and meant it could be assumed the post would be straight throughout its loading cycle.

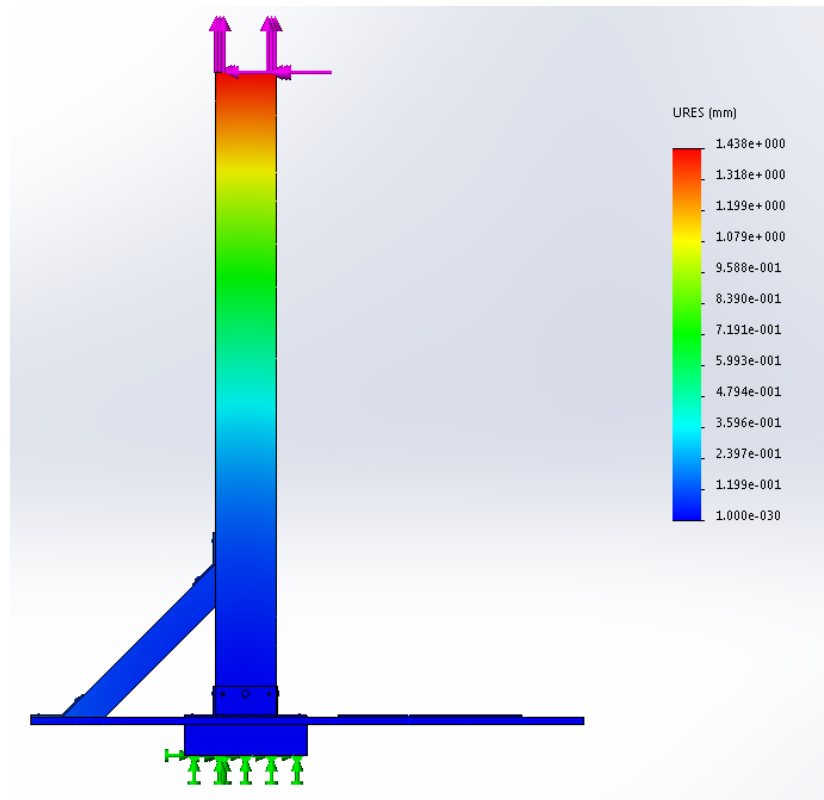

Figure 30 Expected Deformation of the 4x4 Post of the Driving Platform.

### 3.6.3 Roof Protector Simulations

This simulation shows the anticipated tension force of 150 lb acting straight down on the center circle. A custom material was created to allow for an approximation of plywood with an ultimate yield of 14 Mpa. The surfaces inside the bottom holes were assumed to be fixed. Clearly the anticipated von Mises were well within the load limit of this plywood material.

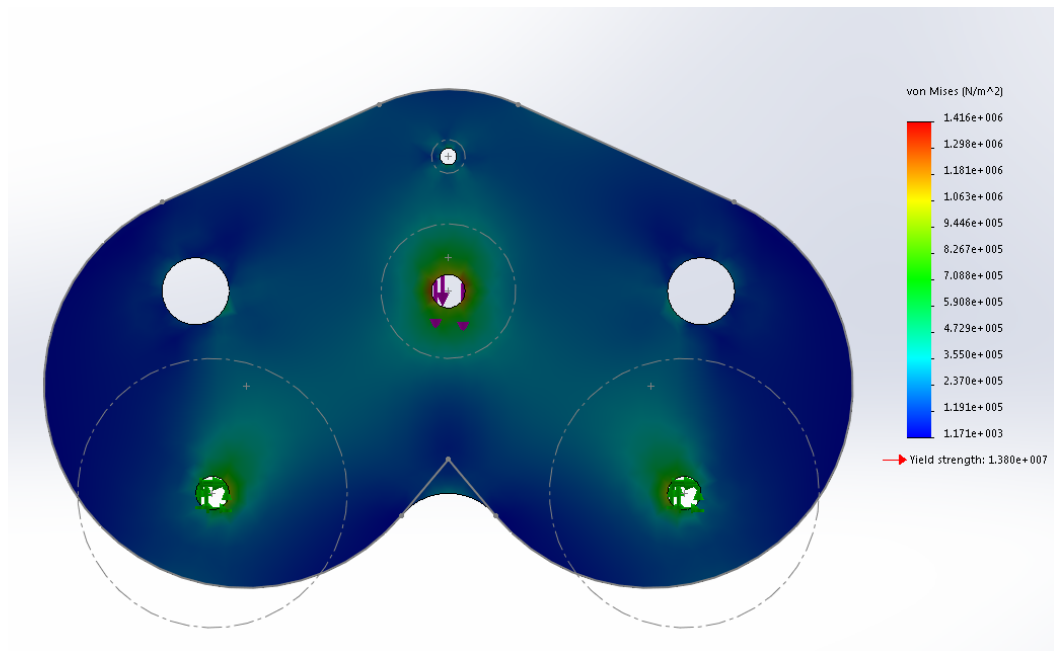

Figure 31: A simulation and visual representation of the expected von Mises on the side of the millipede

## 4. Constructing the Roof Rake

After all of the materials were purchased, there were three primary phases of construction, each one for an individual component of the roof clearing system. During the construction process, there were several design changes made to some of the components. These changes, along with the construction process, are outlined below.

## 4.1 Roof Ridge Protector Construction

The roof ridge protector, also known as the “millipede,” was the first component of the roof clearing system to be completed; however, during the construction process, there were quite a few design changes.

### 4.1.1 First Millipede Prototype

The first prototype of the millipede was planned to be identical to the design formulated in A-Term. It consisted of four, small, inverse-heart shaped devices connected by rope. These devices were intended to be used in a train to provide an area of support over the ridge of the roof. See Figure 32. The body and wheels of these devices



Figure 32: Original Millipede Design

were to be constructed out of plywood and secured by long carriage bolts. After enough



Figure 33: First Millipede Prototype

parts were cut using the laser cutter to assemble one of the four rope guides, it was assembled with  $\frac{1}{4}$ "x6" carriage bolts. After assembly, it was tested on a mock roof. See Figure 34. After this testing, it was determined that the roof protector would be more effective if it were one large rope guide rather than four small ones.

### 4.1.2 Second Millipede Prototype

The second prototype of the millipede was redesigned to be considerably taller and longer, resembling an inverted “U,” as can be seen in Figure 35. The new design would only require that one device be placed on the roof, and would also ride over any roof vents, due to the greatly increased crest-over clearance. This design also utilized plywood, as it is quite rigid and cost effective.

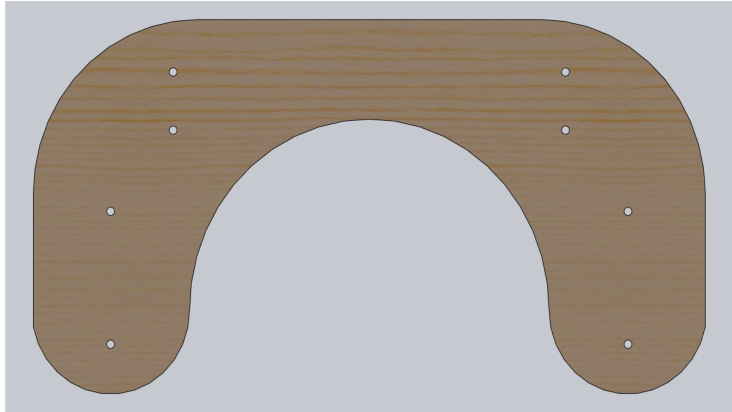

Figure 34: Second Millipede Side Plate

The issue with this design was that it utilized the original carriage bolts of the smaller rope guides; these small bolts created a width of only six inches versus a height of over 14 inches, making the prototype very unstable. Despite this issue, the inverted “U” shape was selected with the decision to create a wider version.

### 4.1.3 Final Millipede Design

In order to increase the width, and as a result, stability of the millipede, the final version uses six threaded rods instead of bolts to connect the two halves. Steel,  $\frac{3}{8}$ ” inch rods were chosen because they were sturdy enough to stand up to the pressures generated by the snow removal and the entire assembly could be held together with bolts and washers. To further increase width, the thickness of the plywood wheels were also doubled. This modification had the added benefit of increasing the surface area of the millipede

contacting the roof. To ensure that the wood wheels roll smoothly on the roof, a steel sleeve was press fit into the wheels to act as a bearing on the threaded axle. Two of the rods on the top of the millipede act as the support for the power rope. In order to decrease friction, a piece of EMT conduit was cut to act as a bearing surface. The final two rods act as additional support and keep the rope on the EMT roller. To help keep the whole assembly aligned, and to increase



*Figure 35: Final Millipede Design*

rigidity, PVC tubing was cut to size and placed over the threaded rods as a support. The final Millipede design can be seen in Figure 36.

## 4.2 Wedge Construction

Construction of the wedge had four phases: bending the sheet aluminum, creating the frame, constructing the breaker bars, and building the tarp roller.

### 4.2.1 Bending the Sheet Aluminum

Before any construction could begin on the wedge, the sheet metal body had to be bent into shape. This was necessary because all other parts are based off the size of the wedge body and a discrepancy in bending could cause another part to be useless. Due to the importance in the accuracy of the wedge body and the difficulty in bending  $\frac{1}{8}$ " aluminum, a professional metal shop was used to form the body of the wedge.



### 4.2.1 Creating the Frame

After the sheet aluminum was bent to shape, the next step was creating a frame that would hold the axles and provide a places for the ropes and breaker bars to attach. The frame was constructed out of four pieces of plywood laser-cut to shape. Taking lessons from the millipede construction, the  $\frac{3}{8}$ " steel rods that were to be used as axles were replaced with a  $\frac{1}{2}$ " threaded steel rods. The heavier threaded rod made assembly much easier and allowed for easy changes to the frame design. Once the wood supports and rods were cut to the appropriate size, six wheels were added, two between each support. Because the whole frame was held together with the threaded rod, it could simply be slid into the side of the wedge body. It was secured in place by two "L" brackets at the back of the wedge body. The breaker bars also served as a secondary method of securing the frame in the aluminum body. To attach ropes to the wedge, a piece of PVC was inserted in the frame. Ropes were passed through holes in the frame and covered in flexible PVC to increase wear resistance. The first frame of the wedge can be seen in Figure 37. The frame was slightly modified after further testing.



Figure 36: First Frame Design

### 4.2.3 Constructing the Breaker Bars



Figure 38: Breaker Bar Support

Once the frame was completed and attached inside of the wedge body, a set of breaker bars were attached to the side of the frame. These breaker bars were simply pieces of  $\frac{1}{4}$ "x  $\frac{3}{4}$ " aluminum stock about two feet long. Using a drill press, holes were drilled to correspond with a metal support bracket, which was bolted onto the inside of the frame. An additional support bar was installed on the side of the frame to increase rigidity.

This bar was made out of the same aluminum stock. To reduce deflection at the top of the bars, a steel rod was attached through a hole drilled in the breaker bars and held in place with lock collars. To strengthen the area where this steel rod was placed, an additional steel bracket was bolted to the aluminum bar (Figure 39). See Figure 38 for a side view of the wedge with breaker bars.



Figure 37: Side View of the Wedge

### 4.2.4 Building the Tarp Roller

This final component of the wedge was the tarp roller, which was attached to the rear of the device. The tarp was fastened to the roller by being compressed between two bars, and twisted around them before being compressed once again. EMT sleeves were placed over the two rods and the tarp to secure them in place. The larger of the two rods is long enough to slide through the two brackets on the side of the frame. This system

ensures that should the sheet rip, changing the sheet becomes an easy task. These brackets are made of  $\frac{1}{8}$ " steel stock and are attached through the same holes as the bracket holding the frame in the wedge, providing additional support. There was about an inch of extra space on each side of the tarp to assist in rolling the tarp onto the wedge. Lock collars were used to secure the rod in place. Enough rod was left on one side to allow for insertion into a drill chuck, allowing for much faster re-rolling of the tarp.

### 4.3 Winching Platform Construction

The construction of the winching platform was relatively straightforward and only a few design changes were made. The platform consists of a  $\frac{1}{2}$ " sheet of plywood used as the standing platform for the



*Figure 39: Winching Platform Support*

operator with a 4" x 4" (nominal) post with the winch attached to the top. The winch will be used to pull the main rope of the front of the wedge. The underside of the standing



*Figure 40: Bottom of the Winching Platform*

platform was reinforced with 2" x 4" (nominal) and 2" x 6" (nominal) for structural support of the platform and the post. More supports were added during the construction due to the lack of support for the operator's weight on the thin plywood base. The support pieces can be seen in Figure 41. The post was attached to the base

using L-brackets on each side as well as a 2" x 4" (nominal) support on the front of the post. A close up of the attachment can be seen in Figure 40. The platform was sanded and painted red to match the millipede. The final Winching Platform design can be seen in Figure 42. The maximum moment expected to see acting on the platform is 450 ft-lbs of torque. This 450 ftLbs is caused by a 180 lb person standing 2.5 ft away. This equates to 150 lbs pulling 4 feet away at an angle of 45 degrees, as shown in Figure 43.

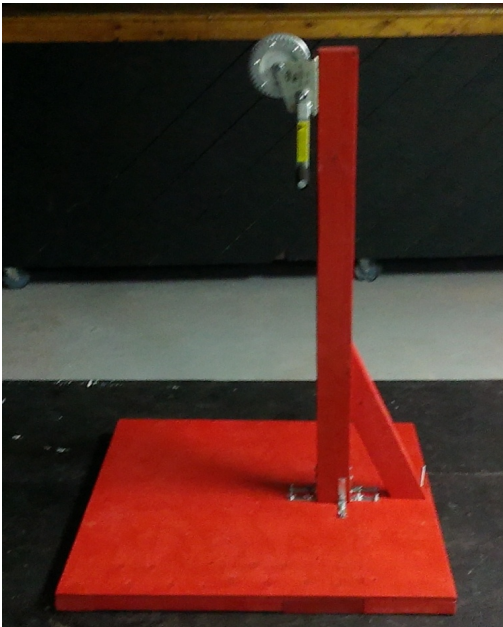

Figure 42: Side View of the Platform

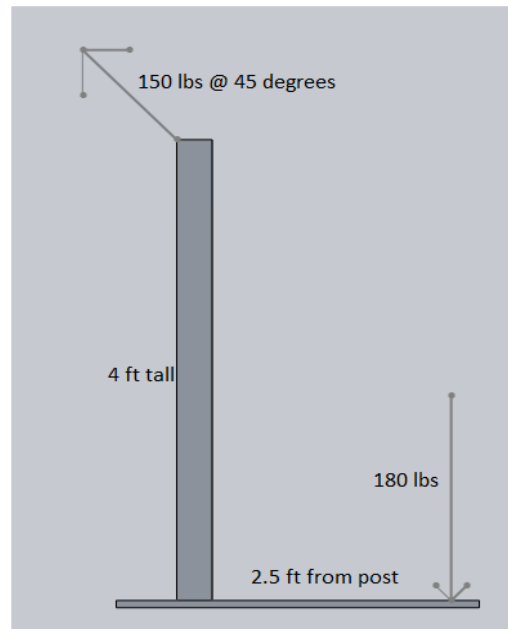

Figure 43 Static Diagram of Maximum Pulling Force Before Tilting

## 5. Preliminary Testing

After all construction was completed about one week ahead of schedule, there was extra time to do some preliminary testing.

## 5.1 Testing Locations

After getting in contact with WPI facilities, two locations were used.

### 5.1.1 Tilted desk

Before permission was obtained from WPI facilities to use the metal HVAC guard, a tilted desk was used as a test for the millipede (see Figure 44). This desk was left in the hallway and was destined for a dumpster anyway, limiting concerns of damaging. For the test, desk was raised to an approximate angle of a roof, and the corner of the desk was used as an approximate roof ridge. The millipede was then raised and lowered without issue or concern. The



*Figure 44: Initial Millipede Testing*

wedge was pulled off the ground to test the structural integrity of the millipede. A noted concern was the millipede could roll off the ridge with enough force. This was easily counteracted by temporarily tying down the millipede's guide ropes. In the field, one of these tie-down locations could be on the winch platform, while the wedge operator could hold another.

### 5.1.2 Metal HVAC Guard

A HVAC guard, seen in Figure 45, was chosen to test the wedge for multiple reasons. The first reason was the ridge was low enough to be reached if there were concerns, and it had an open side where the wedge could swing freely as it would in true operation on a residential roof. Another reason was that it was made of metal, and so it would not be damaged by the ropes or the wedge if an unforeseen issue arose.



Figure 45: HVAC Grate Used for Testing

Permission was obtained to test on the metal HVAC guard, the first tests to be conducted involved the wedge's ability to



Figure 46: Wedge on HVAC Grate

climb over the lip of the roof. The wedge performed well once it was on the roof, but had difficulties climbing over the lip. This test can be seen in Figure 46. The difficulties with getting it up there were solved by two solutions in tandem. First, an additional axle with smaller wheels was placed in the main area of concern. This allowed the worst part of the scraping to be replaced by rolling instead. This final modification can be seen in Figure 47. Additionally, using the

purchased roof rake to push the breaker bar higher allows the center of gravity to be above the wheels already in contact with the roof, preventing scraping.

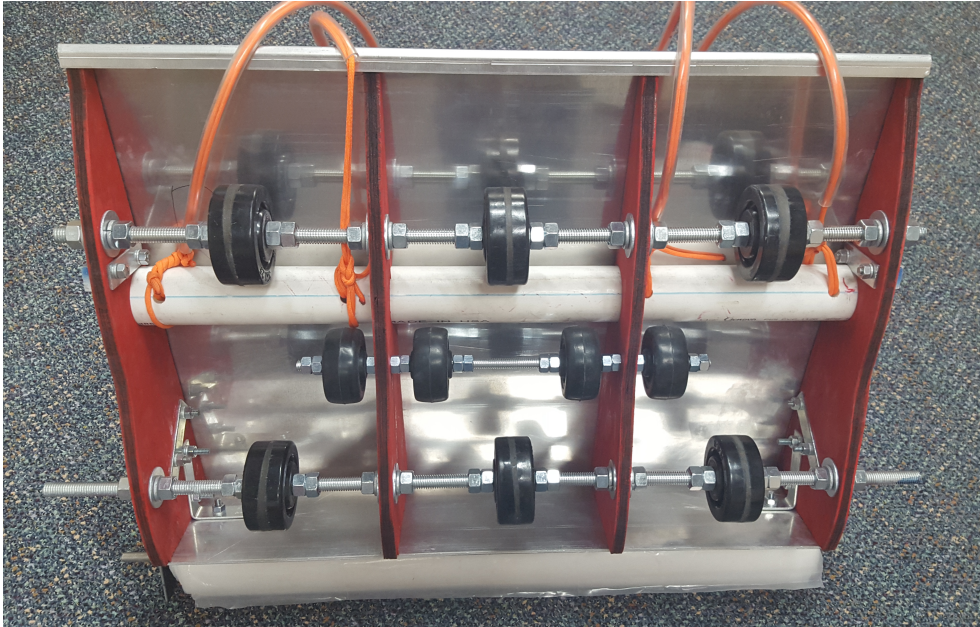

*Figure 47: Final Wedge Frame Design*

## 6. Testing the Snow Removal System on a Roof

After preliminary testing in B Term, and the addition of an extra axle to further reduce the damage potential of the wedge, the snow removal system was ready for further testing.

### 6.1 Testing Location

The first step to continue testing was to secure a testing location, preferably an actual roof; however, as this would be the first test of the equipment on a shingled roof, there was concern

about damage due to unforeseen factors. In order to mitigate the possibility for damage, a storage shed was generously offered by a family member for this first “real” test. This shed, seen in Figure 48, was a good candidate for several reasons: it was shingled, it was low enough to easily observe equipment, and if it were damaged, it would be much less costly to repair than a roof. Unfortunately, the shed did



*Figure 48: Shed Used for Testing*

have a double angled roof. Although this was not ideal for snow clearing, it was sufficient to evaluate the principles of the snow removal system.

### 6.2 Testing Procedure

Although the shed used was not two stories, the procedure followed for testing would be the same used to clear an actual roof. All four members of the team were present for this test. One



was the winch operator, one controlled the wedge, one was the safety observer/communicator, and the final was responsible for recording data and pictures.

After all of the equipment was unpacked and assembled, which took about fifteen minutes, and a rope attached to the millipede was launched over the shed. The millipede, which already had the power rope attached, was then hoisted to the ridge of the roof. Next, one end of the power rope was attached to the wedge and the other was attached to the winch. The wedge was winched to the roof and maneuverability tests were performed.

To move from side to side across the roof, the wedge would be first lowered to the ground. In order to move the millipede, the ropes on each side were pulled in alternating intervals, allowing the millipede to shift its position without requiring additional setup.

Once side-to-side movement was tested, several drop tests were performed on the millipede and the wedge tarp was tested in snow.

## 6.3 Testing Results

After following the procedure outlined above, there were several successes and several failures noted for each component in the snow removal system.

### 6.3.1 Wedge Analysis

Overall, operation of the wedge was a success. There were no issues getting the wedge itself on the roof. As long as the winch was operated in a constant rate and there was a person holding the guide ropes attached to the



*Figure 49: Wedge on the Roof*

rear axle, the wedge itself would stay away from the side of the roof. Once on the roof, as seen in Figure 49, it was easy to maneuver with the two guide ropes attached to the rear axle. Although it was easy to steer the wedge on the roof, there was not enough movement here to set the wedge enough for a new pass. In order to clear a new section of roof, the wedge had to be backed off of the roof and pulled to the side. When this was attempted, the wedge began to pull on shingles as seen in Figure 50. This damage potential, combined with the difficulty of pulling the wedge through at least a foot of snow, makes completely removing the wedge from the roof for each pass unavoidable. While this is doable, it would make the clearing process significantly more time consuming.



*Figure 50: Single Damage with Side-to-Side Movement*

The tarp system also worked well with the limited amount of snow available to testing. Although there was not any snow on the roof, the effectiveness of the tarp was still tested by placing the wedge at an angle and shoveling snow on top of it. The snow slid over the wedge and down the tarp as expected.

### 6.3.2 “Millipede” Analysis

This round of practical testing also proved that the roof ridge protector, the “millipede,” was also of sound design. Like the wedge, the millipede was very simple to get on the roof. Once the first line was shot over the shed, it was simply hoisted to the ridge of the roof as can be seen in

Figure 51. The wheels rolled well on the shingles and the design provided ample clearance for any roof vent running the length of the ridge.



*Figure 51: Millipede on the Roof*

Upon testing, the millipede was able to hold the forces of the rope and wedge without issue. The EMT conduit bearings worked well to reduce friction and the rope never got stuck on the millipede. Several drop tests were also conducted from a height of approximately 10 feet. There was no damage recorded in these tests. Due to its center of gravity, it landed on its wheels each time.

During testing, several issues were encountered with revolved around the ropes attached to the millipede. First, when the wedge was being pulled up the roof, the millipede had a tendency to roll towards the winching platform. To solve this, it was quickly determined that the best course of action was to tie down the millipede with a rope on the side of the house with the wedge. While this worked well in testing because there was a tree directly in line that could be used as an anchor, this has the potential to be a significant obstacle. If a natural anchor point is not available, stakes would have to be used. Stakes would be difficult to pound in frozen ground and can cause damage to plants or the lawn. It would be extremely time consuming, not to mention physically demanding, to drive stakes into frozen ground. Even if the ground was not frozen, the stakes will create ugly holes in the homeowner's lawn. This would certainly deter some homeowners from using this snow rake system over hiring a conventional snow removal company. Alternatively, a

person could serve as the anchor; however, it would increase the number of workers required for the job, which would increase cost.



*Figure 52: Rope Interference*

Although securing the millipede on the side of the wedge stopped it from sliding, it also created its own problem; the single securing rope created interference with the wedge, as seen in Figure 52. Because the rope that prevented the millipede from sliding towards the platform had to be directly in line with the platform, it was directly in the path of the wedge, preventing it from completing a full path without dislodging the millipede.

This interference problem could be solved by replacing the single guide rope and loop on each side with two ropes, each attached at the extreme end of the axles. These ropes could be secured at an obtuse angle, allowing a clear path for the wedge. The additional rope on each side would also help to avoid tipping. There was one instance of the millipede tipping, as seen in Figure 53 during testing; however, using two ropes on each side would have solved



*Figure 53: Millipede Instability*

this. Unfortunately, adding two more ropes makes the system more complex and doubles the points that have to be anchored. When clearing a roof in a least a foot of snow, it is neither realistic, nor practical, to stake down and remove two additional ropes each time a new pass has to be made.

Finally, the ability to move through snow is a concern, since the wheels appeared to drag in less than an inch of snow. These drag marks can be seen in Figure 54. If the millipede's wheels do not roll well in an inch of snow, they will likely not work at all when working in conditions of at least a foot of snow. One potential solution for this issue is to place skis around the wheels of the millipede. This would allow for it to roll on bare shingles without damage and slide on more than a few inches of snow. Unfortunately, the addition of ski feet would not assist in changing its location on the roof for a new pass as it would have to move laterally into a column of at least one foot of snow. This would also mandate that the millipede be removed after each pass. Finally, the addition of weight, possibly in the form of weight plates, might prevent the sliding; however, this additional weight would make operation very cumbersome.



*Figure 54: Millipede Drag Marks*

### 6.3.3 Platform Analysis

The winching platform, seen in Figure 55, was also, overall, very successful. There was no visible bending of the post during winching, and the platform itself was maneuverable enough to be moved without issue. The rope could be quickly attached to the winch, and the winch proved very smooth to use.

The platform's downfall proved to be something that none in the group had foreseen: should the wedge or a knot on the rope get caught on anything, the platform will either slide forward, or the front edge of



Figure 55: Winching Platform in Action

the platform will anchor in the ground, and the trailing edge of the platform will raise off the ground, as seen in Figure 56. This is quite unsettling for the operator, and furthermore, this is downright unsafe.



Figure 56: Platform Tipping

Potential solutions for the platform's problems are to stake the platform down, add cleats to the bottom of the platform, or add additional weight to the platform. Any of these options would add to the moment provided by the operator standing on the platform to prevent tipping while also limiting sliding either through increasing the normal force of the platform or increasing the coefficient of friction between the platform and the snow. Staking the platform down, while it would prevent it from tipping or

sliding, would also have the same downfalls of using stakes to secure the millipede. Adding cleats to the bottom of the platform would be a simpler and less time-consuming option than stakes, yet this still poses problems. Using cleats in snow might not prove very effective. Should the platform rest on snow, even with cleats, the platform would likely still slide. If the platform had contact with the bare ground, the cleats would dig into a homeowner's lawn, and deter the homeowner from using this snow rake system. Should the platform sit on ground, the problem of the trailing edge of the platform raising up still exists.

### 6.3.4 Rope Analysis

During this test, the transfer from theory to practice revealed more issues with the ropes than any other component of the snow clearing system.

The rope performed as expected during testing in terms of strength. There was an ample amount of rope, and at no point during testing did the rope show signs of excessive strain or wear.

The downside to the ropes, the driving force of the entire system, is they proved to be a high potential for shingle damage. During the design phase of the project, it was acknowledged that the ropes could cause shingle damage at the ridge of the roof. As a result, the millipede was designed to protect the roof ridge. It was also postulated that there was a slight possibility for damage from direct contact with the rope; however, if necessary, it was suggested a



*Figure 57: Rope Caught Under Shingles*

plastic sheet could be used to prevent this. Unfortunately, when ropes were placed on the roof, even with no weight whatsoever, they would start to ride under the singles, especially at the ridge

of the roof, as can be seen in Figure 57. Furthermore, the rope would always find the underside of a shingle, regardless of its starting position. For example, should a rope be cast directly in the middle of a shingle, the rope would still wander, and find the underside of an adjacent shingle.

This problem is further amplified when knots are taken into consideration. Knots, or any other attachment point between the wedge and the power rope, have a much higher potential to get caught than originally expected. There were several occasions where a knot did get caught and start to lift up shingles and as a result, cause the platform to slide as previously discussed. Only through careful scrutiny and the ability to see the shingles was damage averted. It is unlikely that a work crew would spot such an occurrence on a second story roof underneath a foot of snow before it is too late.

Unfortunately, all potential solutions involved ropes, which are the issue. In order to raise a protection device up to prevent such an occurrence, one must either use a rope, or climb up onto the roof. Both are unacceptable. Therefore, an alternative solution that does not involve a rope dragging against the roof was sought.

## 6.4 Testing Conclusions

This practical test was a very enlightening process in regards to the practicality of this design. All components of the snow removal system worked as designed, the ropes were strong enough, and the wedge and the millipede were durable and easy to maneuver. Although each component of the system could be considered a success individually, when operating as a system the results were less than satisfactory. The snow removal system was, at its core, too complex and relied too heavily on ropes. Due to its complexity, communication and operation was difficult and ropes would often get tangled. Some of the issues encountered could be solved; however, their



respective solutions would require additional increases in complexity and more ropes, which were the causes of the issues in the first place.



*Figure 58: Problematic Small Roof Vents*

Another concern about the system developed when examining the backs of several of the houses in the neighborhood where testing occurred. One house in particular, had at least four small vents on the rear of the roof, as seen in Figure 58. Previously, many of the houses examined did not have these vents; however, it would be impossible to tell if a particular house had any low profile vents on the roof when it is covered in snow. Furthermore, it is not likely that a homeowner would know the locations of any vents, or even know if they had any. As a result, it is very likely that while using the wedge to clear snow, it could become caught on a vent and very possibly tear it off.

Taking all of these factors into consideration, the best course of action was to redesign a snow removal device that did not rely on ropes traversing the crest of the roof.

## 7. Alternative Design

Although the difficulties with the ropes in the original design made the rake impractical to use, the team was determined to develop a solution. Two simple prototypes were designed and constructed; one of these prototypes completely eliminated the need for a rope over the ridge of the roof, and the other used a plastic sheath to prevent the rope from slipping under the shingles.

### 7.1 The Tarp Roller

The first step in designing a new prototype was looking back at what worked well in the first design. There were two primary design goals for this prototype, simplicity, and limiting the number of ropes attached to the rake. In keeping with the idea of simplicity, the method to get the device on the roof was ignored until the rake itself proved to be effective. Ultimately, it was decided that the core of the device should still involve a tarp to reduce friction and allow snow to slide down the roof.

An idea surfaced for attaching a rope to a chain and pulling the chain down from the top of the roof. Provided the tarp and chain were already positioned at the crest of the roof, the chain would burry itself in the snow on the way down allowing the tarp to be pulled under the snow. Once the tarp was under the majority of the snow on the roof, the snow, in theory, would slide off. This idea had several advantages; it was lightweight, cost effective, and the only ropes used would be pulling down the roof in line with the shingles, rather than against them. One possible downside of this design was that the chain could become twisted, rendering the tarp ineffective. As a result, this chain was replaced with a steel bar.

## 7.2. Testing the Tarp Roller

Testing this tarp and steel bar design was very simple, because a separate prototype did not have to be constructed; the tarp roller on the back of the wedge was almost exactly what was needed. The only modification that was made was the attachment of two ropes, once on each side of the bar, to pull the bar through the snow.



*Figure 59: Bar Drop Test*

The first test conducted, as seen in Figure 59, was a drop test of the bar and tarp to see how deep it would actually cut through snow. Surprisingly, the bar cut almost all the way to the ground, about six inches, when dripped from a modest high. On an actual roof, this would be more than ample, as the bar would dig itself deeper as it was pulled down the roof.

After the drop test proved successful, the next step was to see if the tarp roller could clear a roof. This test, which was conducted on the HVAC guard outside of Higgins, also proved to be very successful. At the beginning of the test, the steel bar was placed at the top of the “roof” with the tarp trailing down one side and the pull ropes down the other side. As the ropes were pulled, the rod initially began to build up a head of snow; however, the rod soon found its way under the head. Once the tarp was under about 80% of the snow, the entire section of snow slid off the “roof”. This entire sequence of events can be seen in Figure 60.



*Figure 60: Tarp Roller Roof Clearing*

Overall, this test proved that the tarp and rod combination could be extremely effective; the only issue was how to get it to the top of the roof. The only feasible solution was to use a remotely controlled quad-rotor type craft to deploy the rod at the top of the roof. The advantages of using a quad rotor is that it could quickly and accurately place the bar for each pass, while at the same time, it would keep ropes from having to cross the crest of the roof. Unfortunately, while feasible, using a quad-rotor for this task might not be practical. Due to the lift capability needed, which would be in the neighborhood of five pounds, any quad-rotor capable of deploying the rod and tarp would cost well over one thousand dollars. Ultimately, the prohibitive cost, new FAA registration requirements, and the skill needed to effectively operate a quad-rotor makes a prototype that could be dragged to the top of the roof much more practical.

### 7.3 The Improved Tarp Roller

With the quad-rotor option possible, but not practical or accessible for many people, modifying the tarp roller to be able to be dragged to the top of the roof was the best option.



*Figure 61: Rope in the Plastic Ribbon*

Unfortunately, the only way to drag the tarp to the top of the roof is to use a rope over the ridge of the roof. While it was easy enough to launch a small line over the top of a roof with the “Big Shot Launcher,” placing this line there created the same potential for damage as out wedge design.

A simple solution for this problem was proposed: to wrap the rope used to drag the tarp to the top of the roof in a plastic ribbon. This ribbon, as seen in Figure 61, was attached to the back of the tarp like a tail. The rope inside the tail was attached to the main tarp with a series of grommets, as seen in Figure 62. Due to the size of this plastic “tail,” the rope was no longer small enough to slip between the small gaps of the shingles. Additionally, because the tarp assembly only weights about five pounds, and that the dragging did not include a snow load, the need for an additional roof ridge protector, such as the millipede, was not necessary.

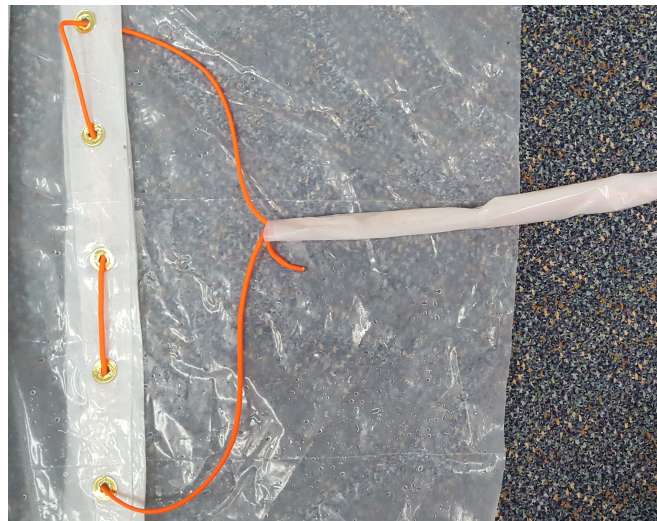

*Figure 62: Attachment of the Ribbon to the Tarp*

Several testes were conducted, which included launching the ribbon “tail” with the Big Shot launcher. While the Big Shot launcher was very effective at launching a bar rope, it was less effective at launching the plastic ribbon. This was likely because of the weight of the ribbon; which was three layers of folded plastic sheeting. If this ribbon were to be reduced to be one layer of plastic tarp, it is very likely that it would have no issues clearing a second story roof. Overall, the tarp roller with the ribbon tail was effective and clearing snow and could be launched by a one or two person team. With a few more tweaks, this prototype could indeed be the solution to removing snow from multiple story roofs.

## 8. Conclusions

This project successfully used the engineering process to address a dangerous situation facing New England homes in the winter, roof collapse. The scope of the problem was researched and a snow removal system was designed to combat it. This system was taken all the way from sketches, to CAD design, to several prototypes until a complete snow removal system had been created was created. Unfortunately, this system did not work as well in practice as it did on paper. This failure could not be attributed to the design on any one component, each of which worked very well on its own. Rather, this failure was due to the complexity of the system as a whole and the unforeseen tendency of the ropes to cause roof damage.

Despite the obstacles presented by the first prototype, the lessons learned form this experience were taken and applied to the creation of two additional prototypes, both of which were vastly different from the original design. These prototypes were highly successful in their limited testing and produced encouraging results. Due to the initial success with the tarp roller prototypes, it is the recommendation of this team that a future project team continue to refine this design and test its effectiveness. If this design were to be carried to completion, it would likely cost less than

\$150 for the tarp and the launcher. This would allow it to compete directly with the high-end snow rakes currently on the market while providing unprecedented capability. This team hopes our work will be used as a basis in the development of a snow removal system that will make snow removal from second story roofs more safe, effective, and economical.

## 9. Works Cited

"Average Annual Snowfall in Massachusetts." *Current Results*. N.p., n.d. Web. 12 Oct. 2015.

Cox, John Woodrow. "Top 10 Snowiest U.S. Cities This Winter." *Washington Post*. The Washington Post, 23 Mar. 2015. Web. 12 Oct. 2015.

Germano, Beth. "Woman Killed In Weymouth Roof Collapse." *CBS Boston*. CBS Boston, 20 Feb. 2014. Web.

Halfpenny, James C., and Roy Douglas. Ozanne. *Winter: An Ecological Handbook*. Boulder, CO: Johnson, 1989. Print.

Hamilton, Anne. "What's A Fair Price To Clear Off A Roof Of Ice And Snow?" *Hartford Courant*. N.p., 01 Feb. 2011. Web. 11 Oct. 2015.

Hoey, Dennis. "Three Deaths in Portland Linked to Snow Removal." *Central Maine*. Portland Press Herald, 05 Feb. 2015. Web.

MacLeod, Dan. *The Rules of Work: A Practical Engineering Guide to Ergonomics*. Boca Raton, FL: CRC, 2013. Web.

Madsen, Jana. "The Top 10 Most Common Roof Problems." *Buildings.com*. N.p., 04 Feb. 2004. Web. Sept.-Oct. 2015.

Mcatte, Paige. "Snow-Covered Roofs Causing Injuries, Deaths in Massachusetts." *Winchester, MA Patch*. N.p., 24 Feb. 2015. Web.

Monarch Roofing. "The Four Most Common Residential Roofing Materials." *Monarch Roofing LLC*. N.p., 17 Dec. 2014. Web. Sept.-Oct. 2015.

Pattani, Aneri. "2 Die in Fatal Falls While Clearing Snow from Roofs in Canton." *BostonGlobe.com*. The Boston Globe, 23 Feb. 2015. Web.



"Police: Watch Out For Roof Snow Removal Scams." *CBS Boston*. N.p., 18 Feb. 2015. Web.

"Regional Snowfall Index (RSI)." *National Centers for Environmental Information*. National Oceanic and Atmospheric Administration, n.d. Web.

"Roofing Component Basics." *Diynetwork.com*. N.p., 2015. Web. Sept.-Oct. 2015.

USA. Massachusetts Emergency Management Agency. *2015 Severe Winter Weather Pattern Impacts - Supplemental Information*. 27 Mar. 2015. Web.

"Will Your Roof Cost You Thousands This Winter." *HomeAdvisor*. N.p., n.d. Web.

## 10. Appendix

### 10.1 Roof Survey Results

Cape	51/200	25.5%
Projections	20	39.2%
Tiers	1	2.0%
Angle	22	43.1%
Chimney	25	49.0%
No Features	9	18.0%

<b>Tall 2 Story</b>	<b>118/200</b>	<b>59.0%</b>
Projections	42	35.6%
Tiers	26	22.0%
Angle	38	32.2%
Chimney	28	23.7%
No Features	29	24.5%

<b>Other Roofs</b>	<b>31/200</b>	<b>15.5%</b>
Pointed	15	48.4%
Flat	2	6.5%
Odd Architecture	16	51.6%

# 10.2 Drawings

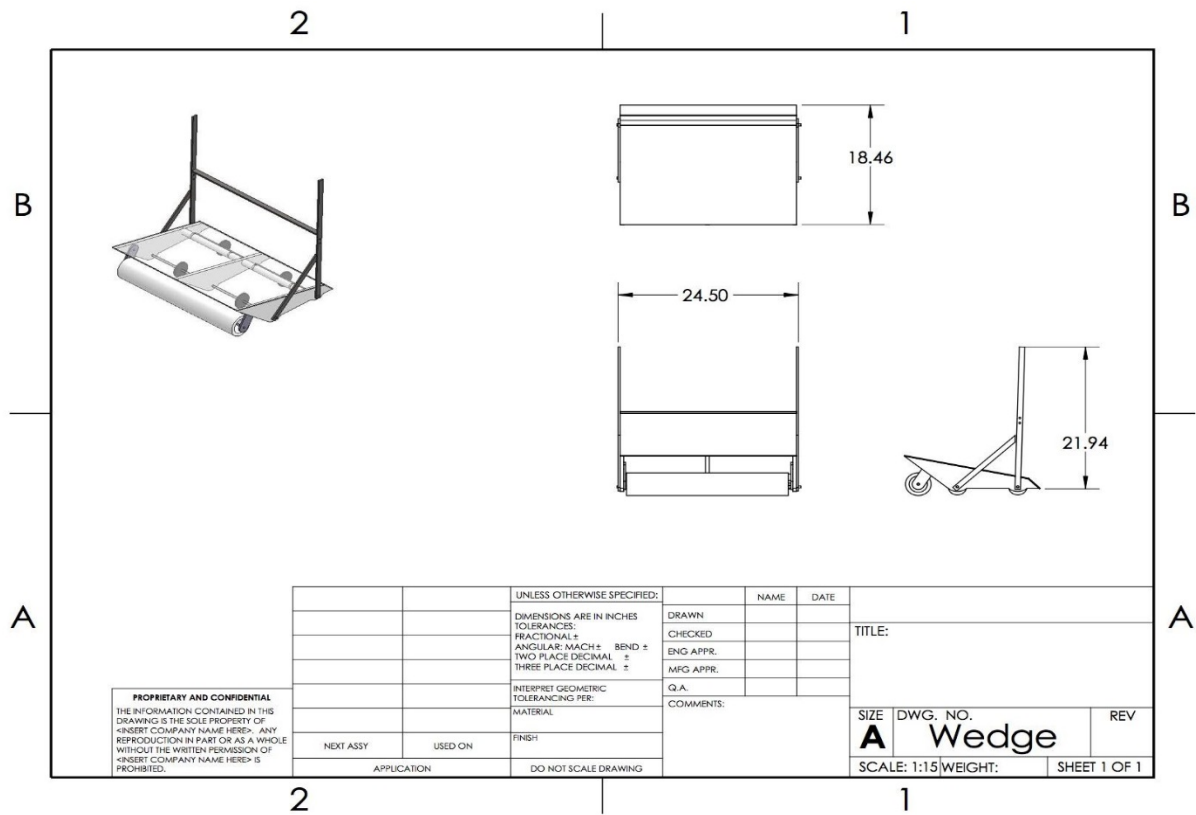

PROPRIETARY AND CONFIDENTIAL  
 THE INFORMATION CONTAINED IN THIS  
 DRAWING IS THE SOLE PROPERTY OF  
 <INSERT COMPANY NAME HERE>. ANY  
 REPRODUCTION IN PART OR AS A WHOLE  
 WITHOUT THE WRITTEN PERMISSION OF  
 <INSERT COMPANY NAME HERE> IS  
 PROHIBITED.

		UNLESS OTHERWISE SPECIFIED:		NAME	DATE		
		DIMENSIONS ARE IN INCHES		DRAWN		TITLE:	
		TOLERANCES:		CHECKED			
		FRACTIONAL ±		ENG APPR.			
		ANGULAR: MACH ± BEND ±		MFG APPR.			
		TWO PLACE DECIMAL ±		Q.A.			
		THREE PLACE DECIMAL ±		COMMENTS:			
		INTERPRET GEOMETRIC TOLERANCING PER:					
		MATERIAL:					
		FINISH:					
NEXT ASSY	USED ON						
APPLICATION		DO NOT SCALE DRAWING					
		SCALE: 1:15		WEIGHT:		SHEET 1 OF 1	

SIZE **A** DWG. NO. **Wedge** REV

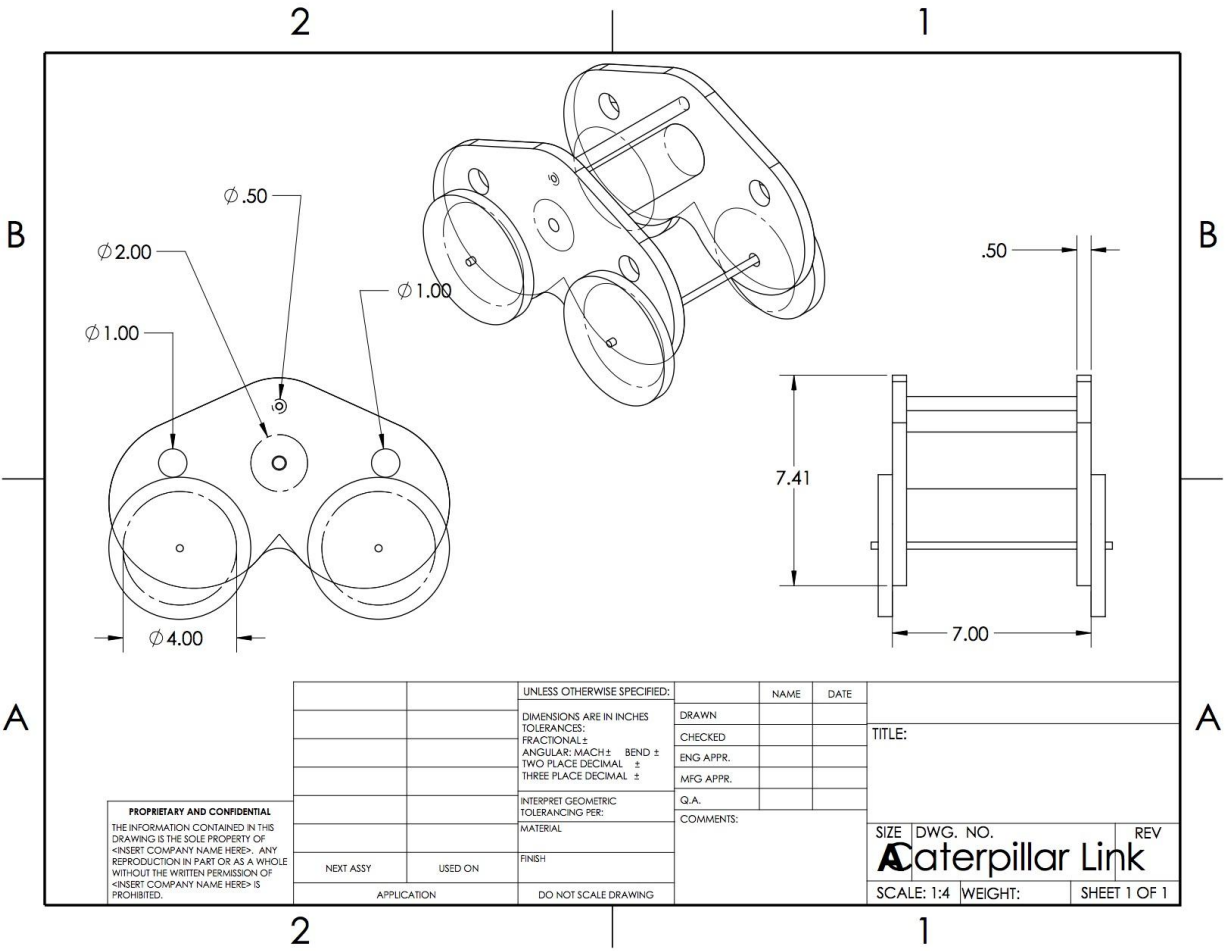

### 10.3 Clearing Diagrams





## 10.4 Construction Bill of Materials

Online Purchases			
Item	Quantity	Vendor	Price
Big Shot Launcher	1	WesSpur	\$116.85
White Specialty Rope	150	West Marine Inc.	\$123.00
1000 Ft. 550 Parachord	1	Amazon	\$55.00
Aluminum Sheet	1	McMaster Carr	\$42.42
3/8 Lock Collar	12	McMaster Carr	\$22.32
Rubber Wheels (2.5 in)	4	McMaster Carr	\$7.24
Aluminum Bar	3	McMaster Carr	\$10.98
Rubber Wheels (3 in)	6	McMaster Carr	\$20.64
Tektron Winch	1	McMaster Carr	\$36.87
Aluminum Rod	1	MSC	\$2.54
Steel Rod	2	MSC	\$17.18
			Total:
			\$423.03

In Store Purchases			
Item	Quantity	Vendor	Price
I/4 ID Tubing	10 ft.	Lowes	\$3.50
Corner Bracket	1	Lowes	\$3.77
4 mil Plastic Sheet	1	Home Depot	\$12.98
Lag Screws	3	Home Depot	\$1.56

Flat Steel Stock	1	Koopmans	\$2.69
½ ID Tubing	4 ft.	Koopmans	\$0.76
Apple Red Paint	3	Koopmans	\$9.12
Corner Bracket	3	Koopmans	\$8.13
½ Threaded Rod (3 ft.)	2	Koopmans	\$4.40
¾ Threaded Rod (3 ft.)	3	Koopmans	\$3.78
Plywood (4*8)	2	Koopmans	\$32.60
Board (2*8*8)	1	Koopmans	\$5.70
4*4 Post	1	Koopmans	Complimentary
2 in. PVC Pipe	2 ft.	Koopmans	\$1.37
½ Inch PVC Pipe	4 ft.	Koopmans	\$0.97
Assorted Hardware		Koopmans	\$72.34
			Total:
			\$163.67