

March 2016

# 2016 Formula SAE Vehicle Electrical Systems Design

George Peter Randel  
*Worcester Polytechnic Institute*

Kevin Ronald MacDougall  
*Worcester Polytechnic Institute*

Follow this and additional works at: <https://digitalcommons.wpi.edu/mqp-all>

---

## Repository Citation

Randel, G. P., & MacDougall, K. R. (2016). *2016 Formula SAE Vehicle Electrical Systems Design*. Retrieved from <https://digitalcommons.wpi.edu/mqp-all/1887>

This Unrestricted is brought to you for free and open access by the Major Qualifying Projects at Digital WPI. It has been accepted for inclusion in Major Qualifying Projects (All Years) by an authorized administrator of Digital WPI. For more information, please contact [digitalwpi@wpi.edu](mailto:digitalwpi@wpi.edu).

# 2016 Formula SAE Vehicle Electrical Systems Design

March 25, 2016

## Authors

Kevin MacDougall  
George Randel

krmacdougall@wi.edu  
gprandel@wpi.edu

---

---

## In Cooperation with

Prof. David Planchard, planchard@wpi.edu

## **Proposal Submitted to:**

Prof. Fred Looft, fjlooft@wpi.edu

---



# WPI

This project proposal is submitted in partial fulfillment of the degree requirements of Worcester Polytechnic Institute. The views and opinions expressed herein are those of the authors and do not necessarily reflect the positions or opinions Worcester Polytechnic Institute.

## Table of Contents

Abstract .....	1
1. Introduction .....	2
Project Statement .....	3
Project Justification.....	3
Conclusion.....	4
2. Background .....	5
ECU/EMS .....	5
Carbureted Engine .....	6
EFI Engine .....	7
EMS Sensors.....	9
Oxygen Sensor .....	9
Throttle Position Sensor (TPS) .....	9
Coolant Temperature Sensor .....	10
Air Temperature Sensor.....	10
Manifold Absolute Pressure (MAP) Sensor.....	10
Oil Temperature Sensor .....	10
Crank and Cam Sensor .....	10
Auxiliary Components.....	13
MSP432 .....	13
TM4C129.....	13
Battery Current Sensor .....	14
Air Pressure Sensor .....	14
Rotary Position Sensor .....	15
Fuel Flow Sensor .....	16
IMU.....	17
GPS .....	17
XTend 900 MHz Transceiver .....	18
Brake Temperature Sensor .....	18
Wheel Speed Sensor .....	19
3. Methodology.....	20
Project Goals .....	20
Team Dynamics/ separation of tasks.....	20

Hardware Design.....	21
Software Design .....	23
Testing and Integration.....	25
4. Engineering Design.....	26
Electrical System Design Overview .....	26
ECU Selection/ integration.....	31
Main Board and Electronics Box Design .....	32
Wheel Board Design.....	33
Steering Wheel Design.....	37
Aerodynamic Sensors.....	42
Wireless Telemetry Pit Computer.....	43
Kill Switch Circuit and Controller interface .....	48
Results.....	51
Conclusion and Future Work .....	53
Appendix .....	54

## Abstract

The 2016 Formula SAE vehicle electrical systems design project provided enhanced electrical systems for the 2016 FSAE vehicle that competed in the Michigan 2016 FSAE competition. This report details the design of the electrical systems implemented on the vehicle including wireless telemetry, steering wheel, wheel sensors, and vehicle dynamics control systems. This report also outlines the design approach and methodology for the systems on the vehicle. Finally, the processes of how the systems were constructed and tested are documented along with recommendations for future work and design.

## 1. Introduction

SAE International is a professional association and standards organization for the automotive and aerospace industries that hosts various national collegiate competitions as part of its Collegiate Design Series (CDS). These competitions challenge students to design and build vehicles as part of a college or university team and then compete with those vehicles against other teams from around the world. In that context, our senior design project team specifically focused on designing and building the electrical systems for a vehicle to be entered in SAE International's Formula SAE competition.

The Formula SAE competition challenges students to create a small racing vehicle that is intended to be used by a nonprofessional individual on weekend track days. The scenario that the competition follows is that a manufacturing firm has asked the Formula SAE team to build a high performance, low cost prototype vehicle for the weekend racers in such a way that it is easy to maintain, aesthetically appealing, and capable of being produced at a rate of four vehicles per day. At the competition the vehicles are put through a series of static and dynamic tests to determine which team has produced the most desirable vehicle for the requirements listed in the scenario. WPI's 2015 Formula SAE competition vehicle in Figure 1 was completed by the members of our senior design project and serves as a first revision of Formula SAE vehicle design.



*Figure 1: 2015 WPI Formula SAE Vehicle*

For WPI's 2016 Formula SAE vehicle, the team aimed to improve upon the existing vehicle in all aspects of design to give the WPI vehicle a greater advantage in SAE International's competition. This report will primarily focus on the improvements and additions made to the 2016 vehicle's electronic monitoring and control systems.

The electronic systems designed for the 2016 vehicle accelerated development time for the vehicle tuners and continues to assist the driver during dynamic events in an effort to address the requirements of the two stages of vehicle development. The two stages in the development of a Formula SAE vehicle are first, vehicle design/functional testing and second, vehicle tuning and operation. Each stage presents a different set of challenges that the electrical system must be designed to operate with.

The first stage of vehicle design occurs early to midway through the development of the vehicle, during which the main objective is to ensure all systems on the vehicle are operational and stable. For the electrical system this means that the engine must be able to be started, must be able to be tuned to idle properly, and the control systems must maintain all measurable parameters within safe bounds. The second stage is when the engine is tuned to yield the best performance in dynamic situations and drivers are trained and familiarized with the vehicle. The electrical system must facilitate the iterative process of engine tuning by providing uncomplicated and fast access to vehicle diagnostic information for the vehicle tuners and it must provide driver aids and control options to simplify the driving experience and enable driver-vehicle communication. The electrical systems in WPI's 2016 formula SAE vehicle meets the requirements for both stages of vehicle development, which gives WPI an advantage over other teams who have not implemented similar systems for time savings in the first stage or fine tuning and driver training in the second stage of vehicle development.

### Project Statement

The purpose of our project was to design, build, test, and fully integrate an electrical monitoring and control system for WPI's 2016 Formula SAE vehicle that would meet the system instrumentation and measurement needs of both stages of vehicle design and development.

### Project Justification

The design of the electrical control and monitoring system for the vehicle is composed of an all in one electrical control unit (ECU) for engine management and an auxiliary electrical system for expanded sensor capability, control, and communication options.

The self-contained ECU controls all of the components related to the operation of the Yamaha YFZ450 electronic fuel injected (EFI) engine that is used in the 2016 vehicle. The ECU is the central part of the vehicle's engine management system (EMS) that interfaces with the rest of the EMS components like: injectors, igniters,  $O_2$  sensors, fuel pump, radiator fan, cam and crank sensors, temperatures, throttle position sensor, etc. The ECU and EMS selection and design is critical to both stages of vehicle development as they are the systems that directly control how the engine runs in an EFI engine. The ECU and EMS are further defined in chapter 2 of the report.

An auxiliary electrical system was needed because most ECUs do not have the capability to be interfaced with, or be programmed for instrumentation needs other than what the ECU was specifically designed for. This means that with a custom hardware and software needed to be designed to gather information about aerodynamic pressures, tire and brake temperature, suspension position, wheel speed, steering angle, acceleration and gyroscopic orientation, GPS location, current draw, and fuel flow. The system also enables the control of functions that are not natively supported by the ECU like electronically controlled shifting for the vehicle's sequential gearbox, wireless video and audio communication, and interfacing with custom driver interaction devices like a steering wheel with built in displays and shift lights.

In dynamic events, the auxiliary electrical system is needed to wirelessly send vehicle diagnostic data from both the ECU and added sensors to, and receive commands from, a pit computer using long range wireless transceivers that require hardware connections and software protocol that cannot be accommodated by the ECU. The ability to wirelessly communicate with the vehicle enables data collection while driving which is influential in vehicle tuning and operation.

Adding an auxiliary electrical system enhances the capabilities of the existing ECU and provides more information and control for the tuner, operator, or driver throughout the vehicle development process.

## Conclusion

The motivations for this project are the desire to perform well in the national competition and the possibility of adding new and useful technology to an existing vehicle. Designing an electrical monitoring and control system for both stages of vehicle development as well as accounting for expanded sensor capabilities gives WPI's Formula SAE vehicle the technological advantage needed to compete against other reputable, high performing schools. This project is of great educational benefit to the students involved and will help boost the reputation of WPI and WPI's SAE club on the national scale come competition time.



## 2. Background

The background chapter explains the concepts, sensors, and devices referenced later in this report. The purpose of this chapter is to explain any potentially unfamiliar concepts and to describe the functionality of the sensors and hardware used in the electrical systems on the vehicle. The following discussions are based on the system diagram presented below in Figure 2, which depicts all the major components of the 2016 vehicle and their associated functional blocks.

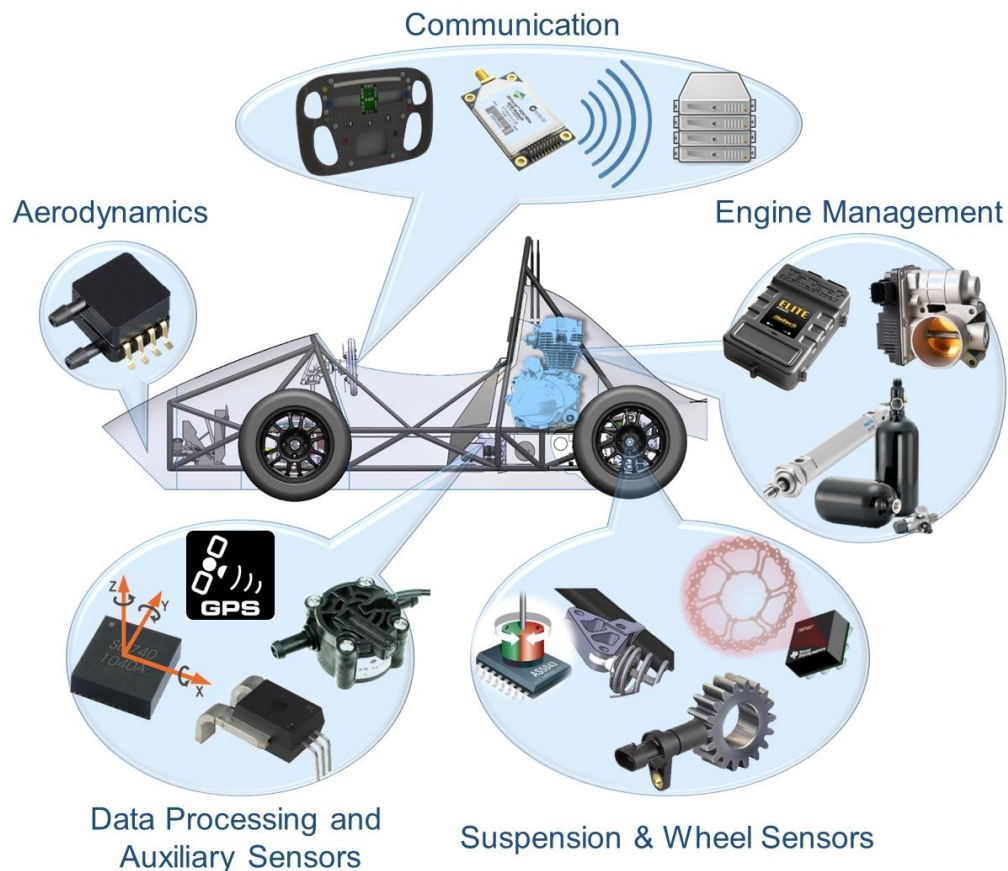

Figure 2: System Diagram for the Electronics in the 2016 Vehicle

### ECU/EMS

There are two types of engines widely used today for SAE vehicles, carbureted engines and electronic fuel injected (EFI) engines. Both engines are similar except for the method used to create the proper air fuel ratio for combustion and the method used to ignite the mixture inside a cylinder using a spark plug. Simply put, a carbureted engine typically uses an entirely mechanical system for creating the proper air fuel ratio and spark whereas an EFI engine requires a computer to control the injection of fuel into the intake air as well as to control the spark timing. The WPI Formula SAE vehicle uses an EFI engine, but both types of engines will be described below in this section.

## Carbureted Engine

A carbureted engine uses a carburetor, as depicted in Figure 3, to mix air and fuel at the engine intake and a distributor, featured in Figure 4, to control the timing of ignition. In Figure 3, the air entering the top of the carburetor represents the atmospheric air coming into the engine before being mixed with fuel. The air passes the choke valve and enters the Venturi, which lowers the air pressure and raises the velocity of the air causing the aerodynamic effects described in Bernoulli's principle to syphon fuel from a thin rod or "Jet" placed in the Venturi. The syphoned fuel mixes with the fast moving air and vaporizes when the passage widens and the pressure lowers after the Venturi.

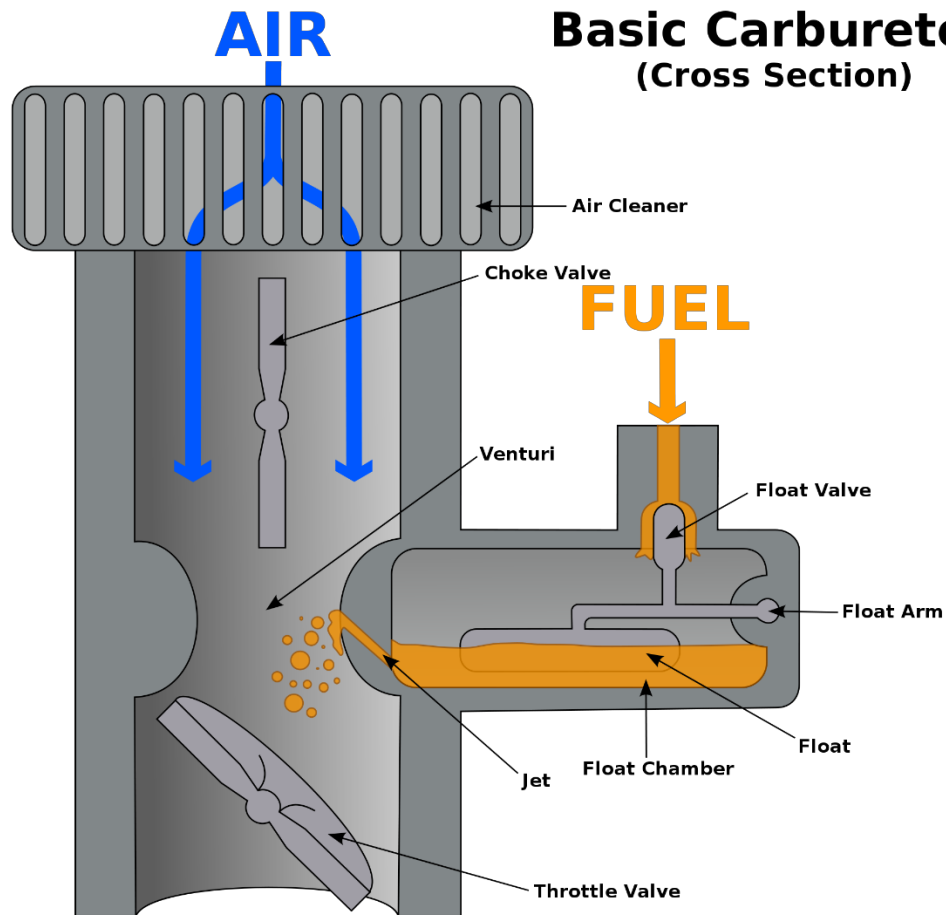

Figure 3: Basic Carburetor Diagram

The air/fuel mixture then enters a cylinder through an intake valve located at the top of the cylinder head and is compressed by the piston. The distributor is then responsible for timing the high voltage spark from the ignition coil to ignite the fuel in the cylinder. In Figure 4 the distributor is shown in the center of an eight-cylinder engine model with spark plug wires connecting the spark plugs in cylinders numbered one through eight to their corresponding contacts on the distributor. This timing is established by the distributor being mechanically connected to the cam shaft (what the cylinder valves are connected to) which, in turn, establishes the timing of ignition based on the position of specially placed cams relative to cylinder head position.

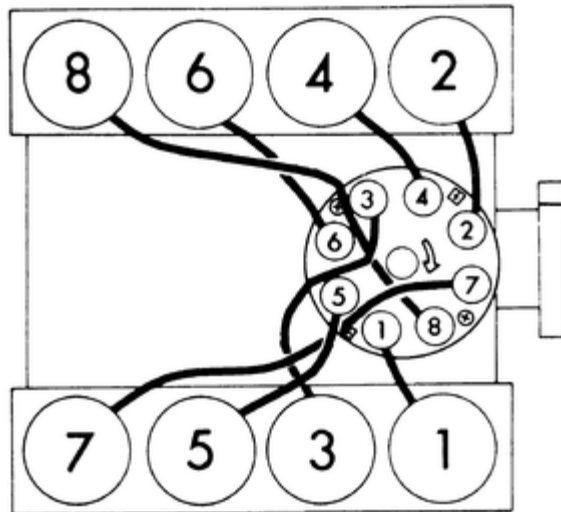

Figure 4: Distributor Diagram

In a carbureted engine, all aspects of air fuel ratio and ignition timing are controlled through mechanical systems with relatively limited tuning capability compared to an EFI engine. The advantages of a carbureted engine are simple and reliable operation without the need for specialized electronic systems.

### EFI Engine

An EFI engine, shown in Figure 5, requires a device known as an injector to spray precisely calculated amounts of fuel into the intake air stream to create the proper air/fuel ratio for combustion. The carburetor is replaced with electronically actuated fuel injectors that use a solenoid to inject fuel and the distributor is replaced with ignition coils coupled with software and electronic switches within the ECU. Specifically the actuation of the fuel injectors is controlled by the ECU, which is part of a broader Engine Management System (EMS). The ECU, shown in Figure 6 contains a computer that interfaces with and controls the sensors and components of the EMS, also known as the engine control loop.

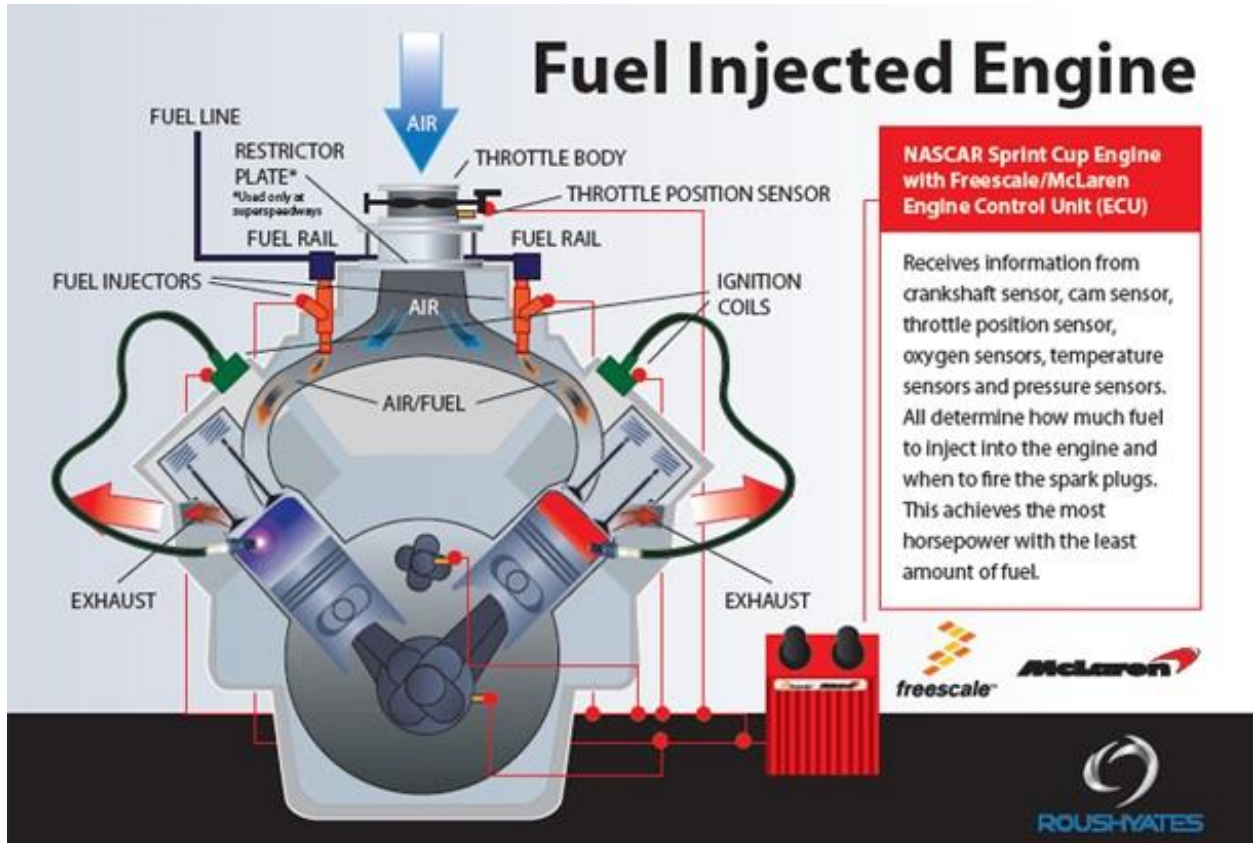

Figure 5: Fuel Injected Engine Diagram



Figure 6: Electrical Control Unit (ECU)

The operation of an EFI engine starts with atmospheric air entering the engine much like the carbureted engine but instead of passing through a carburetor, the air only passes through a throttle body, which acts to modulate the flow of the intake air stream. The throttle body includes only the throttle valve from Figure 3 in an EFI engine. As the intake air stream approaches the cylinders, the ECU uses information from the throttle position sensor along with other sensors like  $O_2$  sensors in a closed loop system, to determine how much fuel should be injected into the intake air stream by the fuel injectors in order to

create the correct air fuel ratio for the cylinders. Once mixed, the air/fuel mixture enters the cylinder through an intake valve and is ignited at the correct time by the ECU controlled spark plugs and ignition coils.

In general, the ECU can be programmed to fire the spark plugs at any time during a revolution of the engine. However, in order to sense the position of the piston in the cylinder during the rotation, the ECU accepts a combination of inputs from the cam and/or crank position sensors depending on the configuration of the engine. Once the ECU senses the piston is in the correct position, a signal is sent from the ECU to trigger the ignition coil for that cylinder's spark plug to fire, thus igniting the air fuel mixture inside the cylinder.

The computer inside the ECU enables engine tuning through easy control over engine parameters such as the air/fuel ratio and ignition timing compared to carbureted engines, but also requires relatively complex sensor systems in order to manage the tuning and operation of the engine.

## EMS Sensors

The sensors discussed in this section include the sensors that are required by the ECU to produce proper air/fuel ratios and ignition timing for EFI engines as well as auxiliary sensors that are not critical to the operation of an EFI engine but are still managed by most ECUs.

### Oxygen Sensor

For the ECU to run the air/fuel ratio system in a closed loop configuration, the ECU needs feedback data from various engine sensors. In particular, the ECU uses an oxygen sensor in the exhaust pipe to measure the percentage of oxygen in the exhaust gas to estimate the air/fuel ratio. When the engine is running "lean", meaning that there is not enough fuel in the intake air mixture, less oxygen is burned in the cylinder and the oxygen sensor senses a high percentage of oxygen in the exhaust. When the engine is running "rich", meaning that too much fuel is in the intake air mixture, then more oxygen is burned in the cylinder and the oxygen sensor senses a low percentage of oxygen in the exhaust. The ECU uses this information to adjust the amount of fuel injected by the fuel injectors to achieve the desired stoichiometric ratio for the fuel being burnt.

### Throttle Position Sensor (TPS)

One of the essential variables the ECU uses to calculate how much fuel to inject to create a desired air/fuel ratio is the throttle position. The throttle position value used in calculations is represented as a percentage. The percentage value correlates to how far open the throttle valve is with 0% being completely closed and 100% being completely open. To measure the position of the throttle valve, a throttle position sensor (TPS) is attached to the throttle valve. The TPS is constructed of a potentiometer and a return spring so that an analog voltage is sent to the ECU that is directly proportional to the position of the valve. The sensor is calibrated by configuring the analog voltage values corresponding to a closed throttle and open throttle within the ECU software. Once calibrated the ECU can determine any throttle position based on the analog signal coming from the TPS.

### Coolant Temperature Sensor

The coolant temperature sensor is used to measure the temperature of the coolant, usually water, coming out of the engine before the radiator in the engine cooling system. The coolant temperature sensor itself is constructed of a sealed thermistor that is placed in contact with the cooling liquid. Coolant temperature is not an essential measurement to the operation of the engine but is necessary to control the radiator fan. Once the coolant temperature exceeds a set threshold, the ECU turns on the radiator fan to maintain temperatures at a safe level. Coolant temperature can also be used as a safety precaution to warn the operator of dangerous overheating conditions and potentially could be used to shut the engine off to prevent damage to internal components.

### Air Temperature Sensor

Intake air temperature is an essential data parameter the ECU uses to calculate how much fuel to inject to create a desired air/fuel ratio. The ECU needs to be able to measure the air density to be able to account for the mass of air entering the cylinder on each stroke. Since it is difficult to directly measure air density, the ECU instead measured the temperature of the incoming air stream with an air temperature sensor. The air temperature sensor is mounted in the intake manifold and uses a thermistor to measure the temperature of the incoming air.

### Manifold Absolute Pressure (MAP) Sensor

Another critical data parameter needed to calculate the mass of air entering the cylinder on each stroke is the manifold absolute pressure (MAP). The MAP is the pressure of the air that is in the intake manifold before the cylinder. Different pressures correspond with different volumes of air in the intake manifold at that time. The MAP sensor is constructed of a MEMS based pressure transducer, and is used to measure the vacuum created by the intake stroke of piston. From the MAP, air temperature, and the engine rpm, the ECU can calculate the amount of air taken in by the engine and predict the correct amount of fuel to inject on the next cycle.

### Oil Temperature Sensor

The ECU monitors the temperature of the engine oil using an oil temperature sensor. This sensor uses a sealed thermocouple in contact with oil in the engine's crankcase to measure the temperature of the engine oil. The ECU and uses the oil temperature data alongside the coolant temperature data to adjust the radiator fan speed. Oil temperature data is not considered essential to engine running.

### Crank and Cam Sensor

It is critical for the ECU to sense the position of each piston in the engine in order to properly time fuel injection and ignition timing. To track the position of the pistons, the ECU needs either a crank or cam sensor to track the position of the crank shaft or cam shaft respectively. Some engine configurations use both types of sensors in parallel to track piston position. The crank shaft connects all pistons together and is the main drive axle for the engine that transfers power to the transmission and the cam shaft sits on top of the cylinders with specially positioned cams that actuate the intake and exhaust valves for each cylinder. Either a variable reluctance sensor or a Hall Effect sensor, seen in Figure 7, may be used for the crank and cam sensors depending on cost and operating conditions.

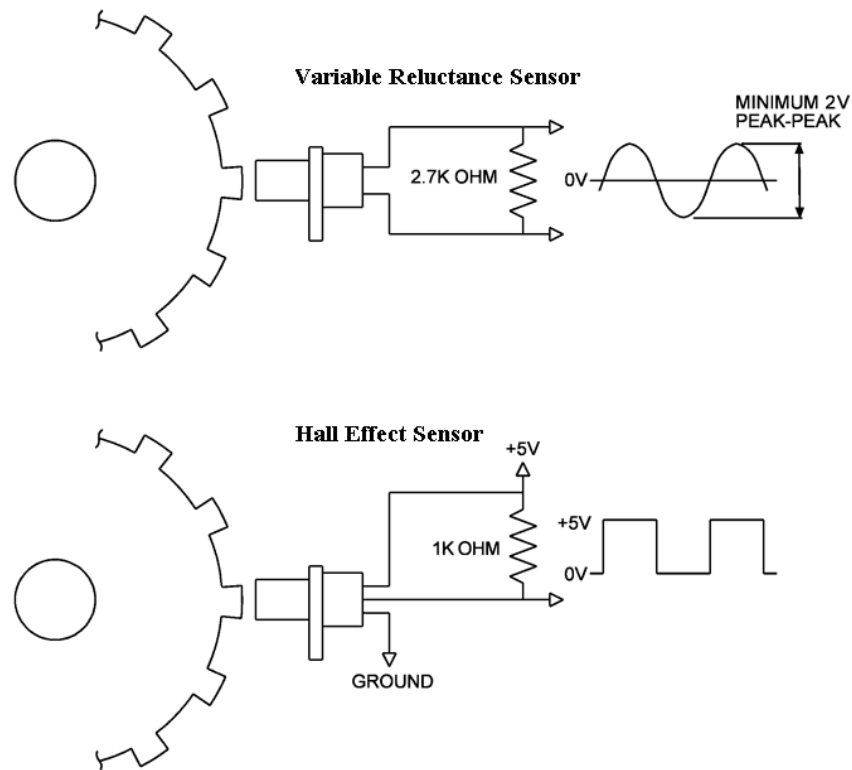

Figure 7: Variable Reluctance Sensor vs Hall Effect Sensor

Both types of sensors work by detecting the motion of a toothed gear in front of the sensor but the method of acquiring a signal and the signal itself is different for variable reluctance and Hall Effect sensors. A variable reluctance sensor is constructed of a magnetized pole that is surrounded by a coil of wire and a sinusoidal signal is induced in the coil of wire when the magnetized pole moves due to the rotation of the toothed gear. As a tooth moves in front of the sensor, the magnetized pole is attracted to it and moves closer to the gear. When the tooth passes, the magnetized pole returns to its original position, thus creating the sinusoidal motion needed to induce a voltage on the coil of wire surrounding the pole. Variable reluctance sensors tend to be less expensive than Hall Effect sensors due to their simple construction and also tend to withstand higher temperatures making variable reluctance sensors well suited for use in hot locations within engines.

A typical Hall Effect sensor for automobile applications produces a clean square wave signal based on the position of a toothed gear in front of the sensor. The square wave signal requires less signal processing in the ECU but Hall Effect sensors are more complicated than variable reluctance sensors and therefore tend to be more expensive. Figure 8 represents how a Hall Effect sensor works. A permanent magnet is held at a distance from a specialized Hall sensor which outputs a “Hall voltage” that is proportional to the magnetic flux density around the device. As the permanent magnet moves away from the hall sensor, the magnetic flux density around the sensor decreases and therefore the Hall voltage decreases. The opposite happens when the permanent magnet moves closer to the Hall sensor. Most automobile Hall Effect sensors are constructed in a switch configuration, which means that the Hall voltage is fed through an amplifier and then a Schmitt trigger with built in hysteresis that switches the

output signal between high and low voltage depending on both the current Hall voltage and the current state of the output signal.

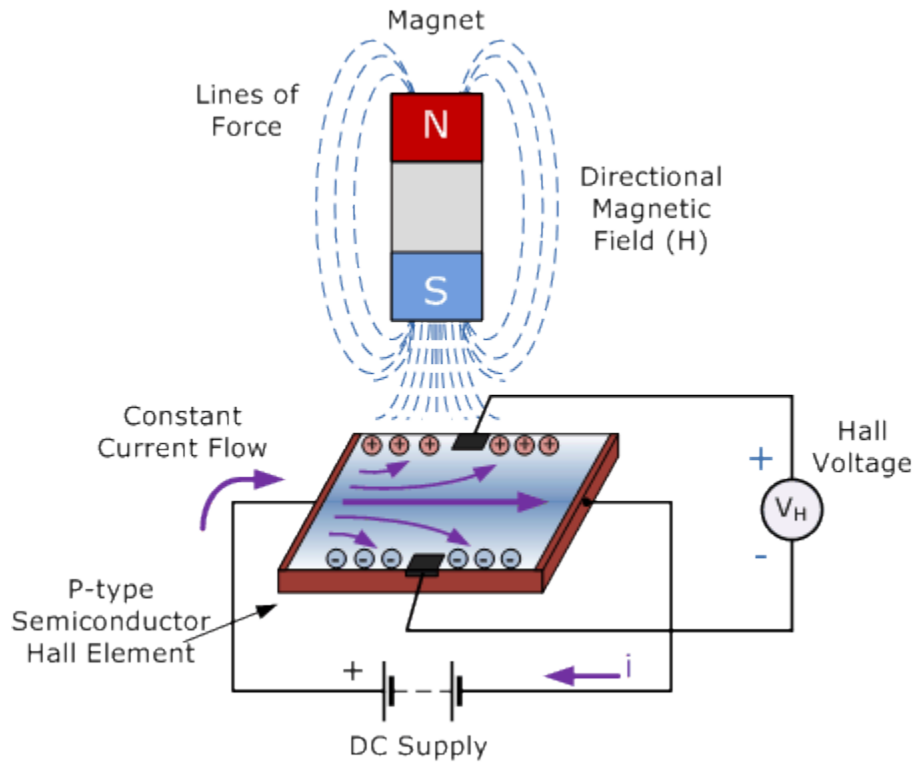

Figure 8: Hall Effect Sensor Diagram

The way the Hall Effect sensor is constructed is that a permanent magnet is placed in front of a Hall sensor with attached signal processing circuit and the permanent magnet is allowed to move slightly within the sensor casing. As a tooth on the gear moves in front of the sensor, the permanent magnet moves toward the tooth, thus decreasing the magnetic flux density around the Hall sensor and triggering the output signal to change. When the tooth passes, the permanent magnet returns to its original position, thus causing the output to switch back to the original value. Because the Hall Effect sensor does not rely on the magnet inducing a voltage in a coil, the sensor can detect the presence of a tooth at very low speeds and even at zero revolutions per minute.

Either a variable reluctance sensor or Hall Effect sensor can be used to detect the position of either the crankshaft or camshaft if the temperature rating of the sensor is high enough. To prepare the shafts for the sensors, a toothed gear is attached where the sensor is positioned so that the sensor can read the passing teeth as the shaft rotates. The way the ECU can sense the absolute position of each shaft is by removing one of the teeth from the toothed gear and waiting for a gap in the sensor signal. The missing tooth creates a characteristic gap in the signal that is used to represent a known position in the rotation of the shaft. The ECU can then count the number of pulses as each successive tooth passes to accurately calculate the position of the shaft with respect to the missing tooth. Every time the missing tooth passes in front of the sensor, the ECU can resynchronize with the shaft position and begin counting



again. The position of the shaft is then used to determine the positions of each piston within their respective cylinders and then timing of fuel injection and ignition can be accurately executed.

## Auxiliary Components

The components discussed in this section are the sensors and hardware that have been included in the auxiliary electronics system to enhance the sensing and communication capabilities of the 2016 Formula SAE vehicle. The sensors in the auxiliary electronics system are not typically managed by most ECUs so a custom hardware and software solution was created to manage and interface with each sensor.

### MSP432

The auxiliary electronics system requires signal processing and communication standards to quickly and reliably collect and transmit data throughout the vehicle. The MSP432 shown in Figure 9 is a 32-bit ARM® Cortex®-M4F microcontroller that operates at a frequency of 48MHz and comes standard with peripherals like SPI, I2C, and a 14-bit ADC. The SPI and I2C peripheral hardware on the chip is required to communicate with the various sensors on the boards throughout the vehicle and the 48MHz ARM® processor ensures that there is enough computing power to sample and process the signals from the high-speed sensors on some boards. The 32-bit architecture also means that more instructions can be executed per cycle than similar MCUs that are 8 or 16-bit because those processors must use more than one cycle to perform calculations on data larger than 8 or 16 bits accordingly. The 14-bit ADC allows for the flexibility to choose from a wide array of precision for the various analog sensors on the vehicle as well. Using the MSP432 simplifies development for each system it is used in by reducing the software overhead required if several different processors were used and accounts for the fact that each system has varying performance requirements by selecting an MCU with flexible performance options.

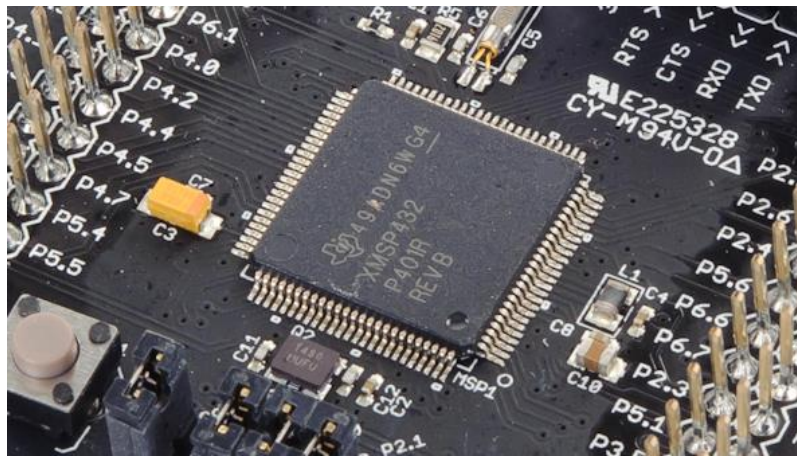

Figure 9: MSP432 32-Bit Microcontroller

### TM4C129

Some systems on the vehicle place high demand on fast code execution, parallel task handling, and transactional I/O load that cannot be accomplished with devices like the MSP432. The Texas Instruments Tm4c1294NCPDT Tiva™ series microcontroller seen in Figure 10 fits the requirements of these systems with its 32-bit ARM® Cortex®-M4F processor at 120MHz. The Tiva™ processor has similar

peripherals to the MSP432 but can operate at much higher speeds, which allows it to handle communications with other systems and data processing with little compromise on message timing delays. The Tiva™ MCU can also handle the interfaces required by some sensors in the electronics system with its array of peripheral interfaces like six UART modules, I2C, SPI, Digital I/O, ADC, and PWM. The systems in the vehicle that need a highly capable MCU for data processing and I/O can use the Tm4c129 to handle their computational load.

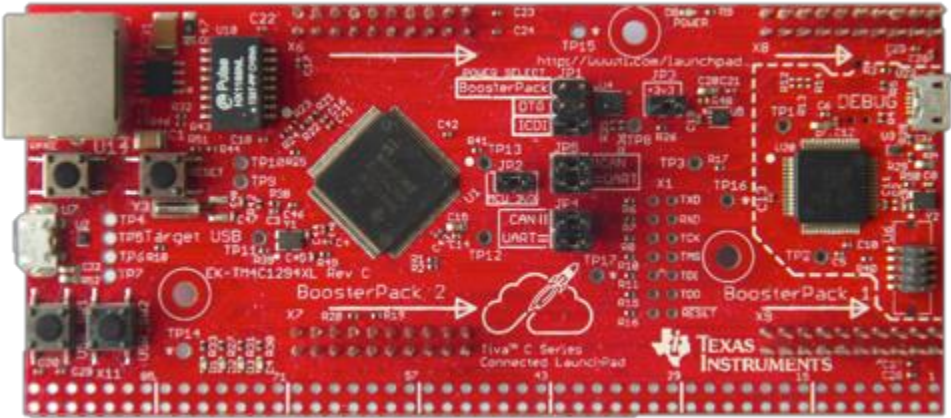

Figure 10: TM4C129 32-Bit Microcontroller Board

### Battery Current Sensor

The battery current sensor in the vehicle measures the flowing into or out of the battery by means of Allegro’s™ ACS756 Hall Effect based linear current sensor shown in Figure 11. The current sensor consists of a precision linear Hall circuit with a copper conduction path connected in series with the battery’s positive terminal located near the Hall sensor die. Applied current flowing through this copper conduction path generates a magnetic field which the Hall IC converts into a proportional voltage that can be measured by the Main board MCU. The ACS756 is capable of measuring +/- 100A DC. The data from the battery current sensor can be used to determine when the battery is charging or discharging and to determine if the battery is running low by tracking the discharge of the battery.



Figure 11: ACS756 Current Sensor

### Air Pressure Sensor

The 2016 vehicle features advanced aerodynamic surfaces that have been optimized for smooth airflow over the vehicle. In order to verify the performance of the aerodynamics on the vehicle, air pressure readings need to be taken at various points on the body. Air pressure at each chosen location, up to a maximum of 20 locations, is measured using Freescale’s MPXV7002DP differential pressure sensor

shown in Figure 12. The pressure sensor uses a piezo resistive monolithic silicon transducer that changes resistance based on the differential pressure between the “pressure” port and “vacuum” port as referenced in the datasheet. The sensor itself outputs an analog signal derived from the changing resistance, which can easily be read by an ADC. The analog signal is directly proportional to the differential pressure as shown in the transfer function in Figure 13. The pressure port is extended to the surface of the body using a short length of tubing and the vacuum ports for all sensors are referenced to each other by connecting them all together. The pressure at each location on the body is sampled by measuring the analog value of each air pressure sensor.



Figure 12: MPXV7002DP Differential Pressure Sensor

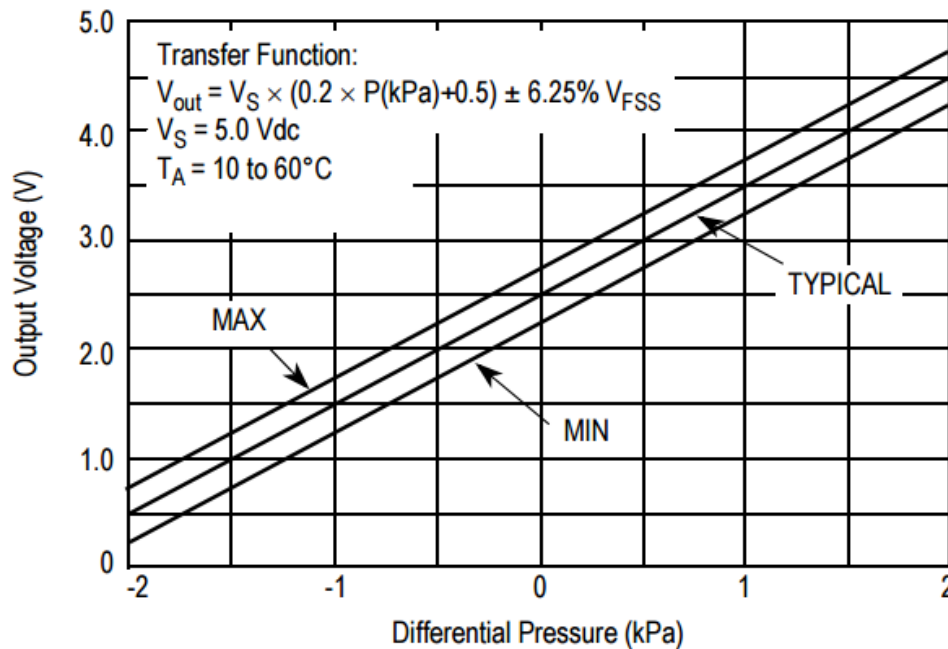

Figure 13: Analog Output vs Pressure Differential for MPXV700sDP

### Rotary Position Sensor

Several applications within the vehicle require the sensing of an object’s rotation, namely the suspension position and the steering angle. The rotation of the objects is measured using AMS’s AS5035 magnetic rotary encoder shown in Figure 14. The sensor works by placing a diametrically magnetized permanent magnet above the surface of the AS5035. The chip uses an array of Hall sensors to sample the vertical vector of the magnetic field distributed across the device package surface and internal circuitry

converts the readings from the Hall sensors into an absolute rotational position of the magnet. The absolute rotational position is then converted into an analog signal that can be interpreted by an ADC as shown in Figure 15.

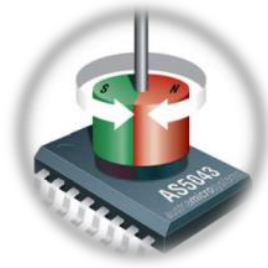

Figure 14: AS5035 Magnetic Rotary Encoder

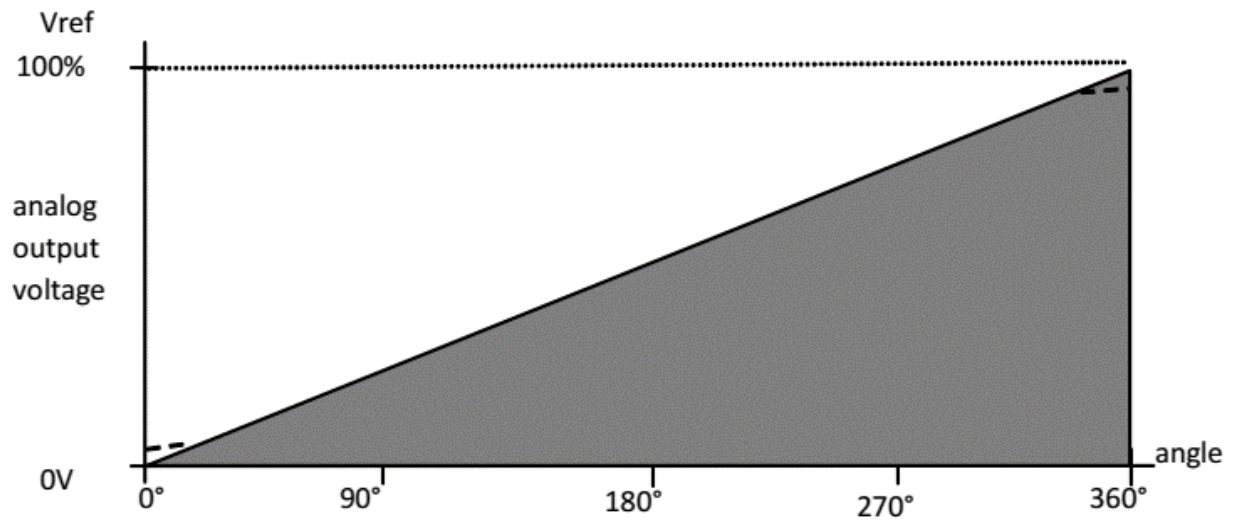

Figure 15: Analog Output Voltage vs Rotation Angle

### Fuel Flow Sensor

A fuel flow sensor was put in series with the fuel feed line to the engine to measure the rate of fuel consumption of the vehicle. The fuel flow sensor shown in Figure 16 consists of a plastic housing with a turbine assembly that the fuel must flow through in order to get from the fuel tank to the engine. The flowing fuel spins the turbine, which in turn generates a pulse on a signal wire for every rotation of the turbine. According to the datasheet, every pulse accounts for 380 $\mu$ L of fuel travelling through the sensor. The MCU then counts the pulses to calculate the total fuel flow in Liters.



Figure 16: Fuel Flow Sensor

## IMU

The vehicle has an Inertial Measurement Unit (IMU) shown in Figure 17 that tracks the vehicle's orientation and acceleration in 3D space. The component used is ST's LSM6DS3 iNEMO inertial module with a 3D accelerometer and 3D gyroscope. The sensor returns X, Y, Z acceleration and rotation data via either an SPI or I2C interface.

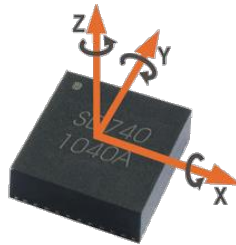

Figure 17: Inertial Measurement Unit

## GPS

The vehicle has a GPS receiver module for logging location data as the vehicle drives around a track. The GPS location data can be used to monitor lap times, acceleration, and speed of the vehicle at any time during a drive. The sensor used is the Venus638FLP GPS receiver module seen in Figure 18. The SOIC handles all of the functions of acquiring GPS signals, calculating location, and estimating accuracy, thus freeing up the host MCU to perform other tasks. The GPS module can acquire location data at rates up to 20Hz and transmit the data to the MCU via SPI. The Venus638FLP allows for the tradeoff between location accuracy and acquisition speed by setting the desired acquisition speed in the internal registers. Slower acquisition speeds improves the accuracy of each measurement.

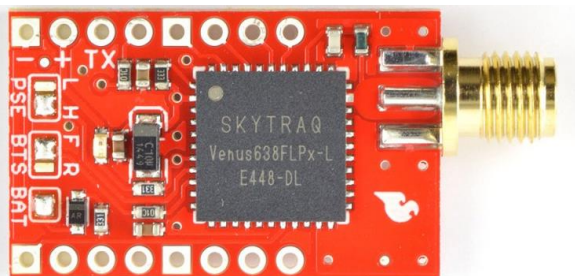

Figure 18: Venus638FLP GPS Module

### XTend 900 MHz Transceiver

The vehicle needs to communicate with a stationary pit computer while driving to relay sensor data to the user interface and logging software. The operating environment for the radio transceivers is a flat semi-obstructed outdoor location with a maximum required range of 2 miles. The transceivers used to connect the vehicle with the pit computer are two XTend 900MHz transceivers by Digi with a maximum range of 7 miles. The XTend modules, one of which is shown in Figure 19, are self-contained units that require only UART serial communication with the MCU to begin transmission. The modules feature built in error correction to minimize erroneous or lost data without placing computational load on the MCU. The modules also handle channel matching and channel hopping to ensure a reliable and reduced interference connection.



Figure 19: XTend 900MHz Wireless Transceiver

### Brake Temperature Sensor

The brake temperature sensor for each brake rotor is Texas Instruments' TMP006 fully integrated MEMs thermopile sensor seen in Figure 20. The TMP006 measures the temperature of an object without having to be in direct contact by absorbing passive infrared energy from an object at wavelengths between 4  $\mu\text{m}$  to 16  $\mu\text{m}$ . The infrared light entering the sensor causes a change in voltage across the thermopile, which is digitized and reported through the I2C interface. The corresponding MCU can then use the voltage information to calculate the temperature of the object in front of the sensor, i.e. the brake rotor.

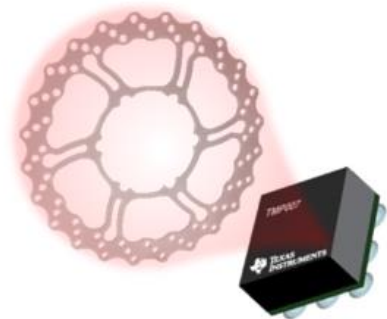

Figure 20: TMP006 IR Temperature Sensor

## Wheel Speed Sensor

The wheel speed sensor is a Hall Effect sensor with a toothed gear, similar to the cam or crank sensors. The difference between the wheel sensor and the cam/crank sensor is that the wheel speed sensor uses a toothed gear without any missing teeth so that the attached MCU only is responsible for counting the pulses from the sensor. Using the dimensions of the toothed gear, a wheel speed can be calculated by the pulse count from the sensor. The specific Hall Effect sensor used for each wheel is Cherry's GS101201 flange-mount gear tooth speed sensor seen in Figure 21.



*Figure 21: GS101201 Wheel Speed Sensor*

### 3. Methodology

The purpose of this section is to describe the methods and procedures used in the development of the Formula SAE vehicle's electrical system and the rationale behind those decisions. In addition to explaining what was done in this project and why, this section covers the goals of the project and why a Formula SAE vehicle needs an advanced electrical system.

#### Project Goals

The goal of this project was to design and build an electrical monitoring and control system for WPI's 2016 Formula SAE vehicle for the purposes of:

- Simplifying vehicle operation for the driver with automatic shifting to minimize the skill and experience needed to drive the vehicle
- Improving on previous engine tuning methods by providing actionable data to the tuners
- Gathering telemetry data to validate design changes made to vehicle components
- Improving vehicle performance to make the vehicle more competitive than previous years

The design of WPI's Formula SAE electrical system adds aids for the vehicle designer, tuner, driver, and maintainer to be able to easily access vehicle diagnostics and control information at any stage in the vehicle development process. Custom interface hardware with the ECU and auxiliary electrical subsystems make the stationary debugging and hardwire connections easier for the vehicle designers during the first stage of development. Wireless communication and telemetry make vehicle control and tuning easier during the second stage of production when the vehicle is best observed and tuned while in motion. The added sensor and control capabilities of the auxiliary electrical systems provide a new range of sensor information and vehicle control that is not available on off the shelf ECUs. Aerodynamic pressure sensing allows for improved vehicle handling diagnostics, tire temperature sensing allows for previously unattainable levels of tire condition monitoring, electronically controlled shifting reduces the complexity of vehicle operation for the driver, vehicle temperature monitoring will allow for expanded data gathering on critical vehicle components, and wireless telemetry enables effective tuning in the second stage of vehicle development. Altogether, the electrical systems of the vehicle provide an advanced control and diagnostics interface with the vehicle's subsystems that both facilitate design and tuning as well as increase the capabilities of the vehicle beyond the standard off the shelf ECU method of engine control.

#### Team Dynamics/ separation of tasks

Though the Formula SAE Electrical System Design senior design project primarily focuses on the electronics of the 2016 Formula SAE vehicle, it is important to note that the designs and manufacturing of the electrical systems depended closely on the efforts of two collaborators. The first collaborator was the mechanical engineering senior design project team that was responsible for aspects of the vehicles design like steering, suspension, engine, transmission, and brakes. The second collaborator was WPI's SAE club, which is a student run organization with a focus on designing, building, and testing vehicles like the Formula SAE vehicle.



The mechanical engineering senior design project team provided key information about not only the vehicle's physical parameters for the fit and finish of the electrical components within the vehicle's design, but also the characteristics of the various mechanical subsystems for interpreting sensor data. The PCBs, sensors, and other hardware needed to be integrated into the mechanical design of the system in order to ensure safe and secure locations for the control modules, accurate positioning of sensors, and neat and organized running of cable harnesses to the various components of the electrical systems. Once all hardware was placed in the vehicle, it was up to the mechanical engineering team to add significance to the data collected by the sensors by providing validation procedures for each sensor that interfaces with a mechanical system and if necessary, the equations and calculations necessary to produce meaningful results from the data collected.

The WPI SAE club, though not a senior design project team, was instrumental in the construction, planning, and competing of the Formula SAE vehicle. The group of students helped to build the vehicle as designed by the senior design project while also possessing the ability to influence, change or create designs based on their feedback and experience gained while working with the vehicle. All work on the vehicle happened in the SAE club shop and is partially funded by the club's budget. The club decides if the vehicle will be taken to competition at the end of the year and if so, the club organizes the trip and any member can choose to attend. It was therefore important to keep the club's interests in consideration while designing the vehicle, as it was mostly club members who were building and driving the vehicle.

### Hardware Design

The design of the electrical system required hardware in the form of printed circuit boards (PCBs) and wiring looms to carry out all of the data collection, signal processing, and power/data distribution throughout the vehicle. Figure 22 depicts the hardware design process for the PCBs on the vehicle, which began with a concept development phase where requirements were drafted for the electrical system and a high-level system block diagram was created for the vehicle. The block diagram was then refined to a point where there were distinct functional blocks, each with its own individual requirements. The requirements for each functional block could then be designed into circuit schematics using Altium PCB designer, a software tool used for the design of circuit diagrams and for PCB layout.

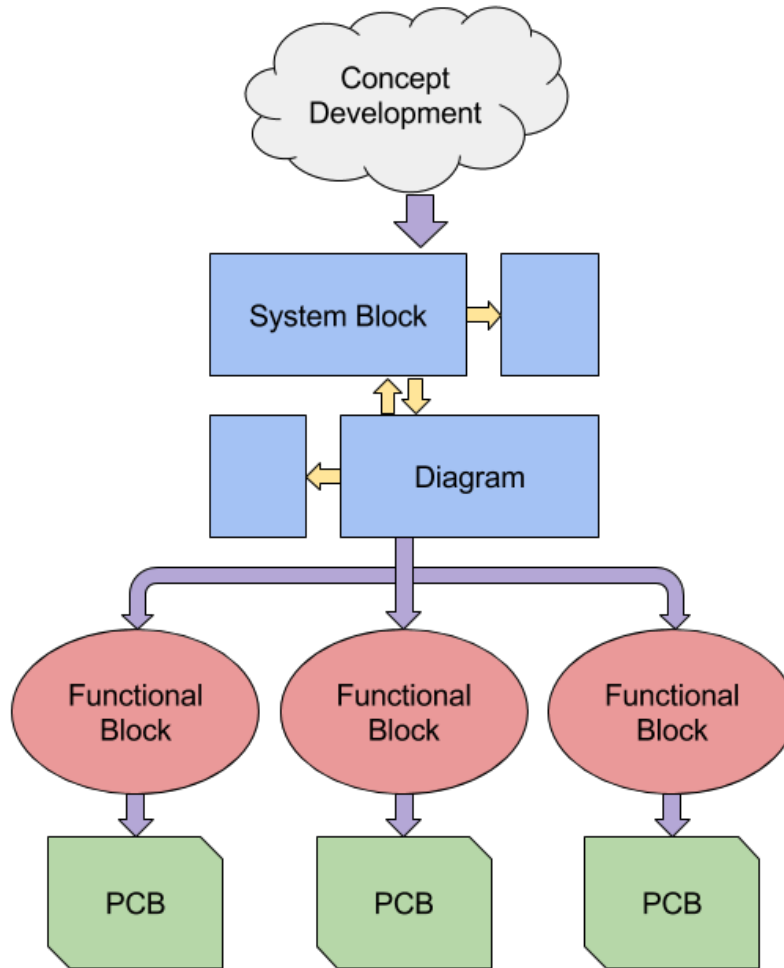

Figure 22: Hardware Design Flow Chart

Component selection occurred while the schematics were being drawn, marking the transition from concept phase to design phase for each of the functional blocks, which is shown in Figure 23. Once the schematics were done, work began on the layout of the PCBs. The work done in that stage included defining the size and shape of the individual PCBs, choosing the position of each component on the PCB, and wiring up the components with PCB traces according to the schematic. The PCB layout stage was also completed in Altium and once the layout for a board was complete, the designs were exported as Gerber files and sent to PCB manufacturers like Advanced Circuits or Osh Park for manufacture. The manufactured boards arrived some time later and were then populated by hand with all of the necessary components. After testing for functionality, the boards were installed on the vehicle and wiring began.

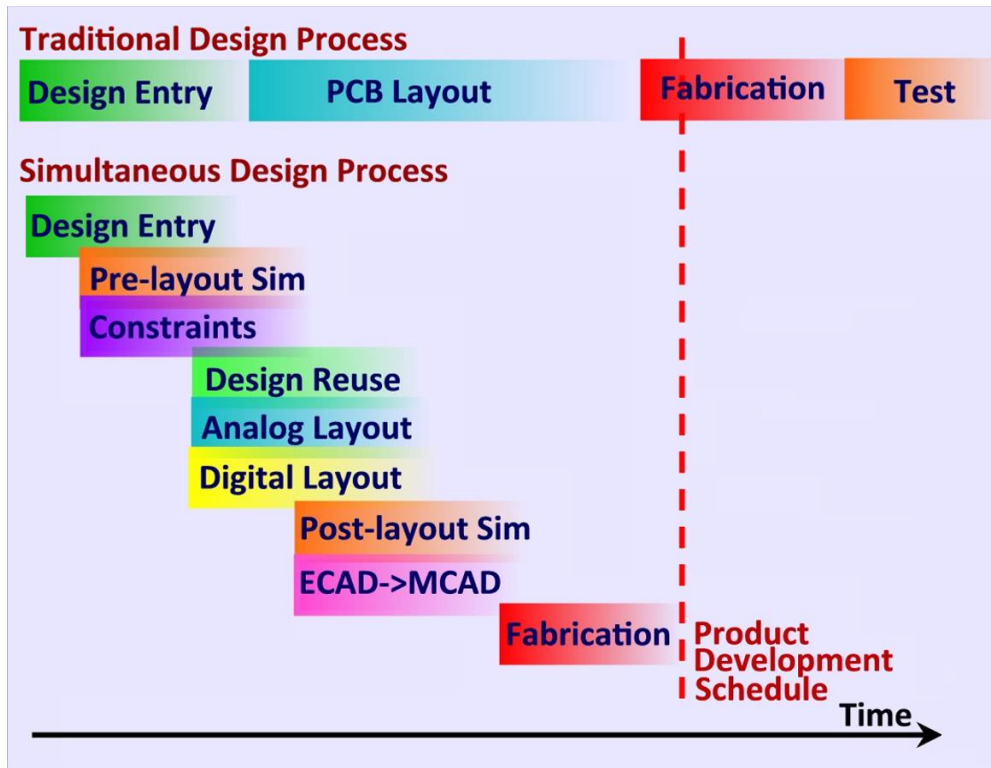

Figure 23: PCB Design Process

The hardware design of the vehicle encompasses the PCBs and wiring in the vehicle and was accomplished using Altium PCB designer, manual board assembly, and manual wiring loom assembly. Each PCB started as a concept that was formed into a functional block, and then circuit design based on the requirements of the electrical system. The PCBs then determined the requirements and design of the wiring in the vehicle based on the location and quantity of each PCB.

### Software Design

The vehicle uses two different Texas Instruments microcontrollers and three different Integrated Developments Environments (IDEs) to run and write all the necessary software that is on the vehicle. All of the microcontrollers are coded in C or C++ and the pit computer is coded in Java via a program called Processing.

Microcontrollers that require register level data manipulation are programmed using Texas Instrument's Code Composer Studio (CCS), a versatile IDE for extracting the most performance out of the microcontrollers in the vehicle. CCS, seen in Figure 24, is a low-level development environment that allows the programmer greater access to the microcontroller's peripherals and debugging options but at the cost of software complexity and time. Fortunately, CCS provides peripheral driver libraries for certain microcontrollers, which makes software development with this complicated tool much simpler. The peripheral driver libraries simplify the initialization and interaction with peripherals on the microcontroller by providing predefined functions that accomplish the complicated tasks that would take excessive amounts of time if done by hand.



Figure 24: Code Composer Studio Splash Screen

Microcontrollers with more relaxed performance requirements and are programmed with Energia. The Energia IDE, shown in Figure 25, is a simplified programming environment that is similar to the Arduino IDE and uses a mix of C/C++. Energia may be restricted in register access compared to CCS but it is far easier to use and requires a fraction of the time spent coding because of its high level coding structure and extensive library availability. By using Energia on microcontrollers with less demanding computational loads, coding intensity for the vehicle as a whole was greatly reduced.

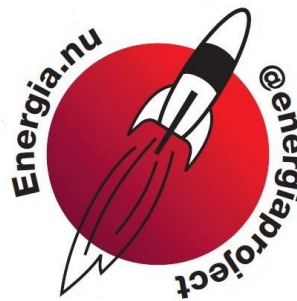

Figure 25: Energia IDE

The Processing IDE, Figure 26, provides an understandable user interface and data recording functionality for the data acquisition functionality of the electrical systems. Processing uses built in libraries and Java to run a graphical user interface (GUI) program to display vehicle parameters. Processing is similar to Arduino and Energia IDEs with the difference that it is focused on creating graphics based programs for displays rather than compiled C code for microcontrollers. Processing also provides options for user control over certain aspects of the vehicle as well as the option to write data to a spreadsheet for later review.



Figure 26: Processing

There are many individual software tasks throughout the electrical control system and many ways of accomplishing those tasks. The appropriate IDE has been matched to each embedded processor to provide the simplest and smartest software solution for the vehicle. Code Composer Studio provides a feature rich environment with the versatility needed by the Main board and Energia and Processing provide the simple yet effective tools needed for the remaining microcontrollers and data display.

## Testing and Integration

The design process for the Formula SAE vehicle required testing at every stage of the design to ensure that the project was on track for completion by competition. Hardware and software testing overlap when dealing with embedded systems and often testing hardware would reveal issues with software and vice versa.

Hardware testing started with circuit simulations in the design phase and progressed to signal probing when the completed PCBs came in. Early design simulations are important to eliminate problems early on in a design. The analog circuits in the electrical system were thoroughly simulated to avoid difficult alterations to PCBs later. The nature of programmable digital circuits eliminates much of the risk in circuit design errors because of the flexibility that comes with microcontrollers but it was still necessary to take the proper precautions when designing any part of the electrical system. After the hardware was assembled, it was tested by running benchmarks on it outside of the vehicle. This allows for easy access to the signals with the oscilloscope for debugging purposes. If any component or design needed changing in the benchmarking phase, it was easy to access and modify before placing in the vehicle. After benchmarking, the hardware was put into the vehicle for integration with the rest of the electrical system. Integration involved testing if the hardware was compatible with the other components in the system and if the hardware retains the same performance it had while benchmarking. Most of the testing after integration focused mostly on the software running on the boards.

Software testing began before any hardware arrived from the board manufacturers. The preliminary software tests were on simulated hardware with development boards and simulated sensor inputs. The early testing narrowed the scope of the software down to which libraries and IDEs needed to be used for each microcontroller in the system. Once the hardware came in, the test software could be applied to the custom hardware for the first time; this revealed any mistakes or incompatibilities of the test software. The software was tested on the custom hardware at same time the hardware benchmarks were happening so that either hardware or software could be changed easily outside of the vehicle to achieve the requirements for that PCB. After the PCBs were integrated into the vehicle, full-scale software tests could begin with each board installed and connected to each other. Full-scale tests revealed errors in communication protocols and sensor accuracy and calibration. Integrating the software of each board involved many minor changes to each board's software to create one cohesive system of microcontrollers and hardware.

## 4. Engineering Design

The engineering design chapter details the low-level designs of the vehicle’s individual electronic systems as well as the integration of each subsystem into one cohesive unit. This section states the functional requirements of each system on the vehicle and describes the interfaces between each subsystem. Also covered are sections dedicated to explaining the design and manufacture of the boards and accessories used to fulfil the functionalities of each system on the vehicle.

### Electrical System Design Overview

The design process for the electrical systems in WPI’s 2016 Formula SAE vehicle began with creating a list of necessary, desired, and optional functionalities for the vehicle. The focus then progressed to making decisions on which functionalities were critical to demonstrate and operate the vehicle given time and budget restrictions. The selected functionalities were then grouped into individual functional blocks, which were organized into a functional block diagram for the electrical system that served as the starting point for the detailed design work for each functional block of the system. Subsequently, each functional block was designed into custom PCBs that, along with software and other electrical accessories, would fulfill the functional block’s set requirements.

The initial planning of the electrical systems for the vehicle involved a tradeoff among the type, rate and fidelity of data that could be instrumented into the vehicle, the cost of the components required to gather the data, and the time required to implement each solution. Within this design context, the SAE design teams created a list of functionalities that the vehicle’s electrical system needed to implement and then organized the list as shown in Table 1. The table sorts the functionalities into those that are critical to vehicle success, those that are desirable given enough money and time for implementation, and those that are optional and could be eliminated without reducing the usability and configurability of the vehicle.

*Table 1: Electrical System Functionality Ranking*

<b>Necessary</b>	<b>Desired</b>	<b>Optional</b>
<b>Tachometer Display</b>	Inertial Measurements	Tire Temperature Sensing
<b>Speedometer Display</b>	Steering Position Sensing	
<b>Engine Temperature Display</b>	Suspension Position Sensing	
<b>Battery Voltage Display</b>	Electronic Throttle	
<b>Gear Selection Display</b>	Electronically Controlled Shifting	
<b>ECU Communication Interface</b>	GPS Location Tracking	
<b>Relay Control</b>	Speed Sensing	
<b>Wireless Communication</b>	Fuel Level Sensing	
<b>Safety and Rules Compliance</b>	Battery Charge Sensing	
	Aerodynamic Pressure Sensing	
	Brake Temperature Sensing	

After performing initial research on the remaining functionalities, the team decided that it would be cost effective and time efficient to move forward in the design process. The functional block diagram in Figure 27 provides a visual representation of how the functionalities from Table 1 were grouped into

individual functional blocks as well as providing a general indication as to where these functional blocks are located on the vehicle. Creating functional block diagram for the vehicle was an important step in the design of the electrical system because it was the first chance for the team to bring the mechanical and electrical designs of the vehicle together. The placement of the electronics within the vehicle is dependent on the vehicle's mechanical design; therefore, it was important at this stage to work closely with the mechanical designers of the vehicle so that positioning, mounting, and space for the electronics could be seamlessly incorporated into the design of the vehicle.

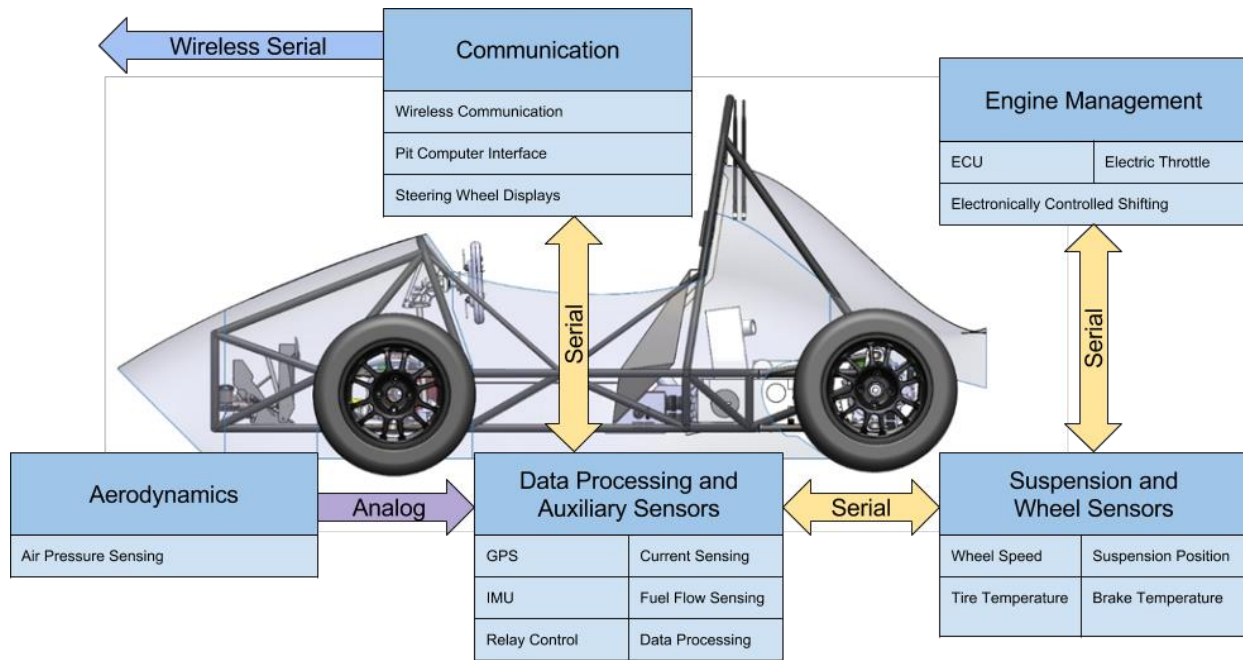

Figure 27: Electrical Systems Functional Block Diagram

The functional block diagram features a CAD drawing of the 2016 Formula SAE vehicle in the center surrounded by the functional blocks of the vehicle's electrical system. Starting from the top of the diagram and working in a clockwise manner are the communication, engine management, suspension and wheel sensors, data and auxiliary sensors, and aerodynamic functional blocks. The functionalities from Table 1 that were approved by the team were distributed among the functional blocks and are represented by the various sensors and mechanical components that were later chosen to fulfill the functional requirements.

The communication functional block is the interface between the vehicle's electronic systems and both the driver and the members of the team in the pit. This block handles the displays and inputs for the driver of the vehicle and the real time vehicle telemetry data for the pit crew. The electrical systems for driver interaction provide updates for all of the various display requirements like tachometer, speedometer, engine temperature, etc. and the systems for pit communication are responsible for wirelessly transmitting vehicle telemetry data gathered from the vehicle's sensors.

The engine management functional block includes all of the systems required to operate the engine and drivetrain assembly in the vehicle. The electronics systems are responsible for enabling the use of an electronic throttle, enabling pneumatically actuated shifting, and utilizing all of the sensors in the engine management system (EMS) to operate the vehicle's EFI engine using an off the shelf ECU. The electrical systems in the engine management functional block are integral to the team's goals of using electronic throttle and pneumatic shifting.

The suspension and wheel sensors functional block applies to each of the vehicle's four wheels and handles data acquisition for each wheel individually. The team was interested in measuring suspension position, wheel speed, tire temperature, and brake temperature. The unique benefit of this functional block is that only one system needed to be designed for all four wheels because the requirements for each of the sensors like distance to the brake rotors and suspension rocker arm movement is nearly identical for each wheel. The design for suspension and wheel sensors functional block was created once and manufactured four times, reducing complexity and saving time.

The data processing and auxiliary sensors functional block has the most requirements to fulfill out of any electrical system and is referenced as the "main" system on the vehicle. This system is the driver for the communication functional block because it is responsible for gathering and interpreting all of the data collected from the systems throughout the vehicle and relaying the interpreted data on to the driver interface or pit communication interface. In order to gather all of the data from other systems in the vehicle, the data processing and auxiliary sensors functional block has an ECU communication interface, suspension and wheel sensors functional block interface, aerodynamic functional block interface, and an array of auxiliary sensing capabilities. This functional block acts as the "hub" of the vehicle's information flow and data processing.

The aerodynamics functional block interfaces with the aerodynamic bodywork on the vehicle and serves the purpose of validating the bodywork design by measuring and comparing air pressures around the vehicle to air pressures that were calculated in computational fluid dynamics simulations. The aerodynamic functional block therefore converts air pressure data on surfaces of the vehicle's bodywork into usable data that can be interpreted and used by the aerodynamics designer.

The functional block diagram for the vehicle clearly defined the requirements for further design of the vehicle's electrical systems and provided a foundation for the creation of the system block diagram. The system block diagram in Figure 28 depicts the hardware organization of the vehicle's electrical systems. Each block in the figure represents a discrete module that was incorporated into the vehicle for the purpose of fulfilling the requirements of the functional block diagram. The interconnecting arrows represent the method used to communicate between blocks and the direction of information flow.



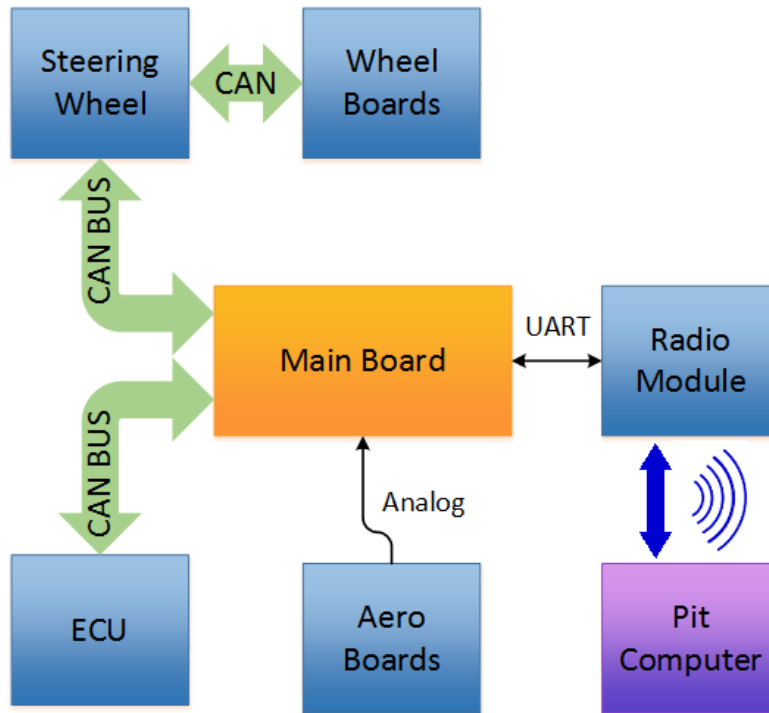

Figure 28: System Block Diagram

The Main Board is the central hardware component in the vehicle’s electrical system. The main board is a custom PCB that is placed below the driver’s seat pan in a waterproof enclosure referenced as the vehicle’s electronics box. Every other electrical hardware component on the vehicle connects to the Main Board so it features two separate CAN bus interfaces, analog inputs, digital I/O, and a UART interface. The driver interface and wireless telemetry is made possible by the data processing capabilities of the onboard MCU. Several data inputs, like the onboard GPS unit, aero pressure sensors, and ECU’s engine data broadcast require the main board to handle the task of parsing and reformatting the data into a simpler and more compact format as to reduce the load on the wireless link and to match the format that is expected by the pit computer. The Main Board also controls the shifting of the vehicle by actuating the appropriate pneumatic valves to shift the vehicle’s gearbox up or down a gear. The design and functionality of the Main Board is discussed further in the Main Board and Electronics Box Design section of the report.

The custom steering wheel on the vehicle features a daytime visible LED display with onboard data processing and tactile, reprogrammable buttons for driver input. The driver’s interaction with the vehicle’s electronic systems is all handled through the features of the steering wheel. The displays update the driver with vehicle information and the buttons allow the driver to control aspects of the vehicles operation like ignition and voice communication. The steering wheel also features paddle shifters for the driver to control the shifting of the vehicle when the vehicle is in manual mode. The Steering Wheel Design section in this report covers the many design considerations for the steering wheel including ergonomics, aesthetics, and electrical interfacing.

The wheel boards on the vehicle account for a majority of the baseline sensors in the electronics system. There are four custom PCB wheel boards on the vehicle, each with suspension position, wheel speed, tire temperature, and brake temperature sensors. A wheel board on each wheel means that the vehicle tuner can monitor the activity of all four wheels simultaneously to validate the performance of the suspension tune, measure the contact patch of the tire based on the tire's temperature rise, and measure brake bias by comparing the temperature rise of the front and rear brakes, among many possible uses. The Wheel Board Design section of the report explains how the wheel boards interface with each sensor, how the boards are mounted to each wheel, and how the wheel boards communicate with the Main Board.

The data link that connects the Main Board, steering wheel, and wheel boards is the automotive standard CAN bus for its resistance to electrical interference and high data rates. The CAN bus allows many devices to be attached to the same data bus, allowing for easy communication among the boards in the vehicle. CAN bus is also used by the Main Board to communicate with the off the shelf ECU. The noise resistance and the capability of having multiple transmitting and receiving nodes on the bus make CAN bus perfect for the electronic systems in the vehicle.

The aero boards on the vehicle are custom interface boards for the air pressure transducers that are used to measure the pressure of the air over the vehicle's body surfaces. The number of aero boards on the vehicle is reconfigurable with the main board handling a maximum of twenty aero board inputs. The aero boards have built in features for analog signal integrity, which is explained further in the Aerodynamic Sensors section of the report.

The ECU system block represents the off the shelf ECU used in the EMS for the vehicle's EFI engine. The ECU interfaces with the Main Board by broadcasting engine data over one of the vehicle's CAN busses. The stream of engine data from the ECU allows the Main Board to retransmit the engine data back to the pit computer so that the tuners and pit crew can monitor the status of the engine systems wirelessly. More information on the ECU and EMS of the system is provided in the ECU Selection/ integration section of the report

The radio module in the system block diagram represents a set of radios and antennas on the vehicle that are responsible for wireless telemetry, driver voice communication, and live video feed. Telemetry data is provided by the Main Board and is transmitted using a long-range transceiver. Voice communication and video feed are both individual off the shelf systems that have been integrated into the design of the vehicle. The Wireless Telemetry Pit Computer section in the report details the design and interfaces of the wireless link between the vehicle and the pit computer that carries the wireless telemetry data.

The pit computer block is the only section of the vehicle's electrical system that is not physically on the vehicle itself. The pit computer is a PC that has been installed in the team's trailer for receiving the wireless signal transmitted by the vehicle. Live video, voice, and telemetry data are all received through antennas mounted to a retractable mast on the trailer and fed to the PC inside of the trailer. The pit

computer has the task of displaying and recording all of the telemetry data received from the vehicle as well as displaying the video feed and enabling voice communication with the driver. The features of the pit computer and the software written to handle the data and displays are discussed in the Wireless Telemetry Pit Computer section of the report.

### ECU Selection/ integration

Many different ECUs on the market would suit the needs of the Yamaha YFZ450R engine in the vehicle and most cost about the same and have approximately the same sensor interface capabilities. The differentiating factors that steered the ECU selection were support for drive by wire and the inclusion of tuning software. Drive by wire is a method of throttle control where the mechanical linkage between the throttle pedal and the throttle valve is replaced by an electronic throttle pedal and an electronically actuated throttle valve. The ECU needs to be able to read the throttle pedal position and use that data to control the position of the throttle valve. The engine tuner also had the most experience Haltech software, so for this reason and the fact that certain Haltech ECUs support drive by wire, a Haltech ECU was selected. Within the range of ECU solutions provided by Haltech, only the Elite series ECUs support the required drive by wire functionality. The FZ450R engine in the vehicle is a single cylinder engine meaning that only one fuel injection output and one ignition output is required from the ECU. Haltech offers two variants of the Elite series ECUs, the 1500, which supports four cylinders and 2500, which supports eight cylinders. For the purposes of reducing cost, the less expensive Elite 1500 was chosen. Figure 29 shows the placement of the Haltech Elite 1500 on the seat pan firewall of the vehicle. The ECU was placed in an easily accessible location on the vehicle so that diagnostics cables can be attached and removed yet it is still located close enough to the engine area to keep cable lengths as short and neat as possible.



Figure 29: Haltech Elite 1500 Placed on the Vehicle

## Main Board and Electronics Box Design

The Main board and electronics box interface all of the electrical systems on the vehicle. This section details the system design and construction of the electronics box, the hub of the vehicle's electronics system. The main systems that needed to be integrated with the Main board are the Haltech ECU, the power management system, the air pressure sensors, and the vehicle's CAN bus. The Main board shown in Figure 30 connects all of these systems together, allowing for one central connection for all of these sub systems.

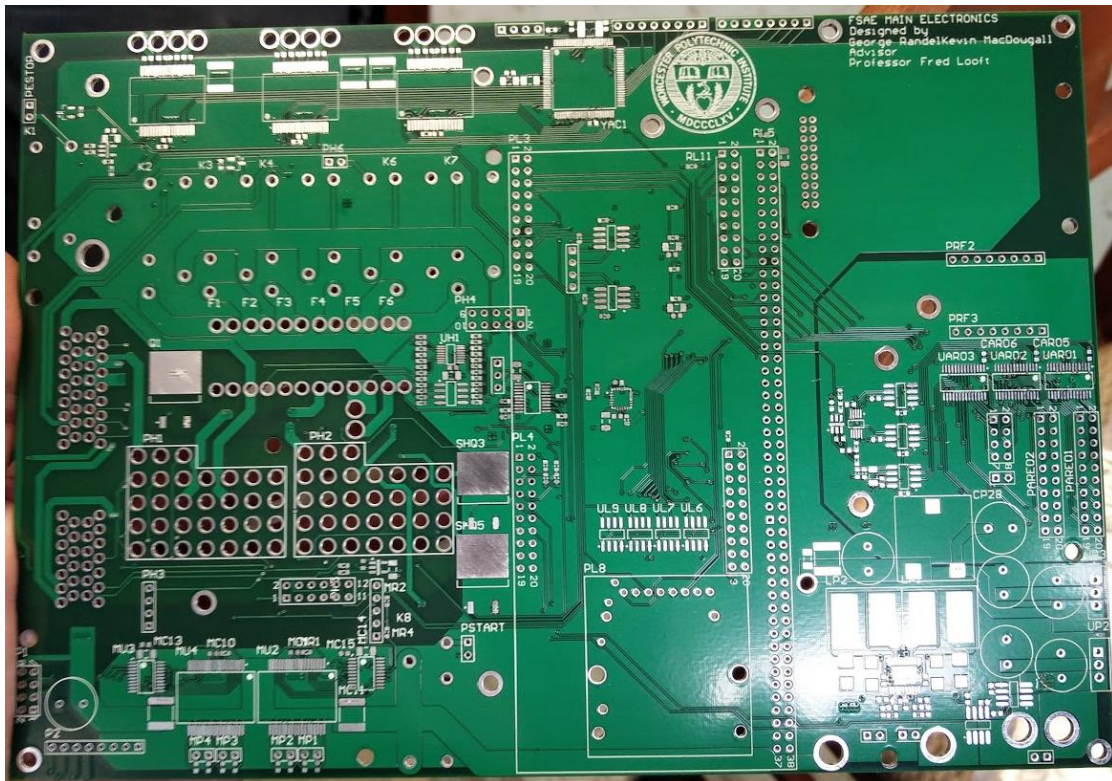

Figure 30: Main Board PCB

The Main board interfaces to the data sources and other subsystems on the vehicle and sends a condensed version of the aggregated data wirelessly to the pit computer. The sensor data from the wheel boards and the steering wheel are transferred over CAN bus similar to how the engine parameters are transferred from the ECU. The two CAN buses are isolated however; one is for sensor data and one is for drive train data and control. This isolation prevents issues with noncritical systems from propagating to the critical systems like engine control. To support the two CAN buses the Main board contains two CAN transceivers one for general sensors, and one for drive train.

The Haltech requires support to operate the engine. The supporting systems are the relays and fuses used by the ECU to drive systems like the spark plugs, fuel pump, and injectors. The relays that would normally be controlled by the Haltech are now controlled by a microcontroller on the Main board, which allows for a wireless emergency stop, and wireless control over other relays. The Haltech connects to the Main board through large pigtailed connectors that contain all of the input and output wires. The I/O is then routed to

the correct places on the board, which then leave the main board through two 31 pin circular connectors. This means that the complexity of a normal wiring harness is contained to the board, reducing size and complexity of the vehicle's wiring. This also means that the entire engine can be disconnected through four connectors. Two for engine control and two for umbilical and starter motor. This makes repair and modification of both the electronics box and engine easier, as well as reduce potential error that can arise with many connectors.

The Main board also contains the auxiliary systems the vehicle needs such as fan control, shift control, wireless systems, and the necessary power supplies. The shift system takes commands from the main microcontroller and actuates the pneumatics to either upshift or downshift. The cooling system manages the two cooling fans on the vehicle turning them on when need and off when not needed. The wireless consists of the XTend module used for transmitting telemetry to the pit computer, and the GPS, which is used to both determine the vehicle's position on track and to calibrate the vehicle's speed. The power system consists of three parts, the first is a set of linear regulators used to power the analog system such as the pressure sensors, the second is the switching regulator used to drive the digital system, and the third part is the filtered 12v output used for the vehicle wide CAN bus. The schematics for the Main board can be found in the appendix.

### Wheel Board Design

Many parameters about the wheels and the suspension on the vehicle are useful in learning how the vehicle is performing. The main parameters of interest are tire temperature, wheel speed, suspension position, and brake temperature. These parameters allow for the tuning of camber and toe of the wheels seen in Figure 31, as well as suspension stiffness and brake bias. The Wheel board allows for the collection and processing of this data for all four wheels.

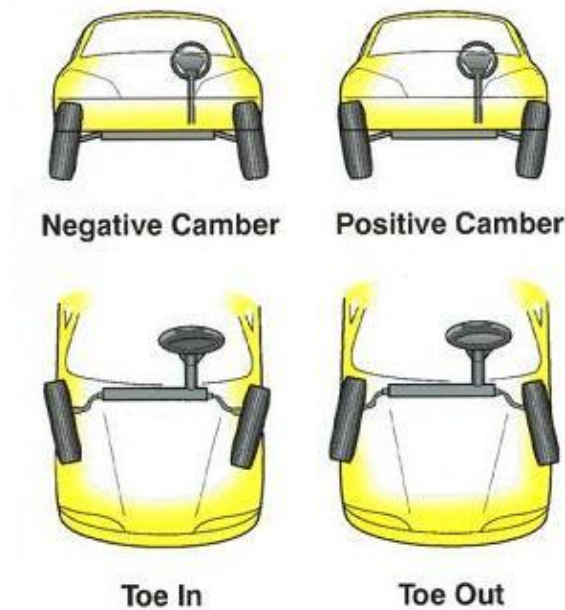

Figure 31: Camber and Toe Depiction

Understanding how the tires are behaving on the vehicle is critical to understanding how the vehicle is behaving, which can be used to improve lap times. This is because the tire is the only interface to the road and it is the main limiting factor on lap times. To measure the temperature across the tire, an infrared camera is used. The sensor is an AMG88 Grid-EYE 8X8 infrared sensor array seen in Figure 32 that samples at a rate of 10Hz. The output of the sensor can be seen in Figure 33, which is showing the temperatures in degrees Celsius of a soldering iron tip that has been left to cool for a few minutes. This temperature data is used to show the hot spots on the tires, which corresponds to the wear on the tire allowing for accurate tuning of the suspension.

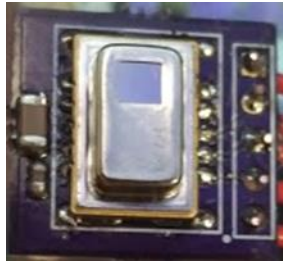

Figure 32: Tire Temperature Sensor



Figure 33: Tire Temperature Sensor Output

The brake temperature is also measured by the wheel board, which is seen in Figure 34 and Figure 35. The brake temperature is useful for two reasons, one it allows for the tuning of brake bias and two it allows for brake overheating warnings. Brake bias can be measured and validated because the amount of kinetic energy being dissipated by the brake can be measured through the temperature of the rotors, allowing for the adjustment of the forward and reverse brake bias. Temperature warnings are used to tell the driver if the brakes are overheating during a race, which can warn of brake fade before it happens. Brake fade is a reduction of braking performance due to high temperatures in the rotors and brake pads so the temperature warning allows the driver to reduce the amount of braking to cool the brakes down. To measure the brake temperature, a TMP006 single chip infrared thermometer is used, U2 in Figure 34. The sensor measures with a 60-degree conical field of view, and integrates the temperature over the whole field of view. One issue with the measurement system can be seen in Figure 36, which is that the vehicle uses drilled brake rotors; this means that the sensor could potentially see open air in part of its field of view, which would reduce the accuracy of the temperature measurement. For this reason, the sensor board was placed as close to the rotor as possible to reduce the amount of holes the sensor sees.

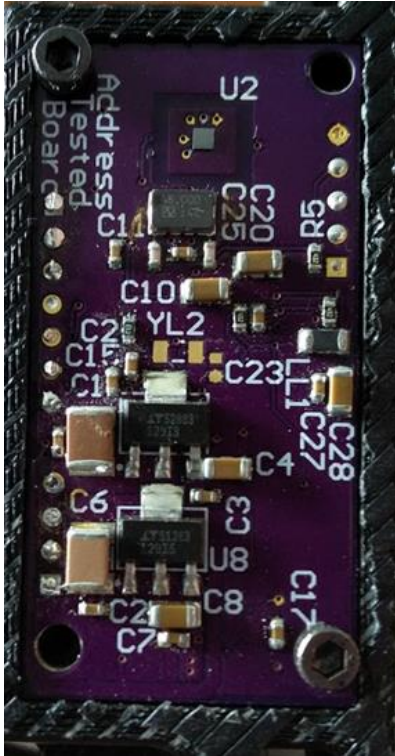

Figure 34: Rotor Facing Side of the Wheel Board

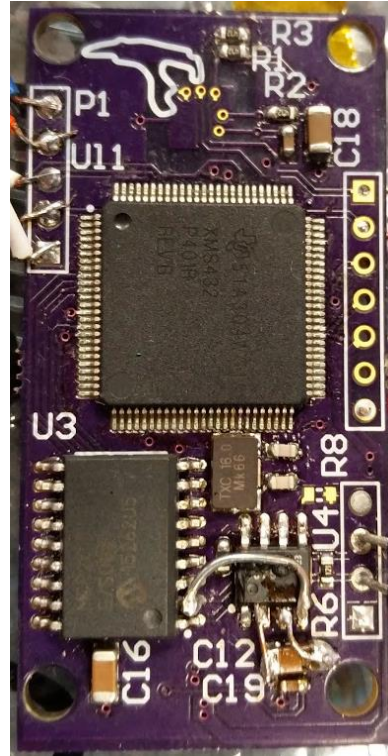

Figure 35: Vehicle Facing Side of Wheel Board

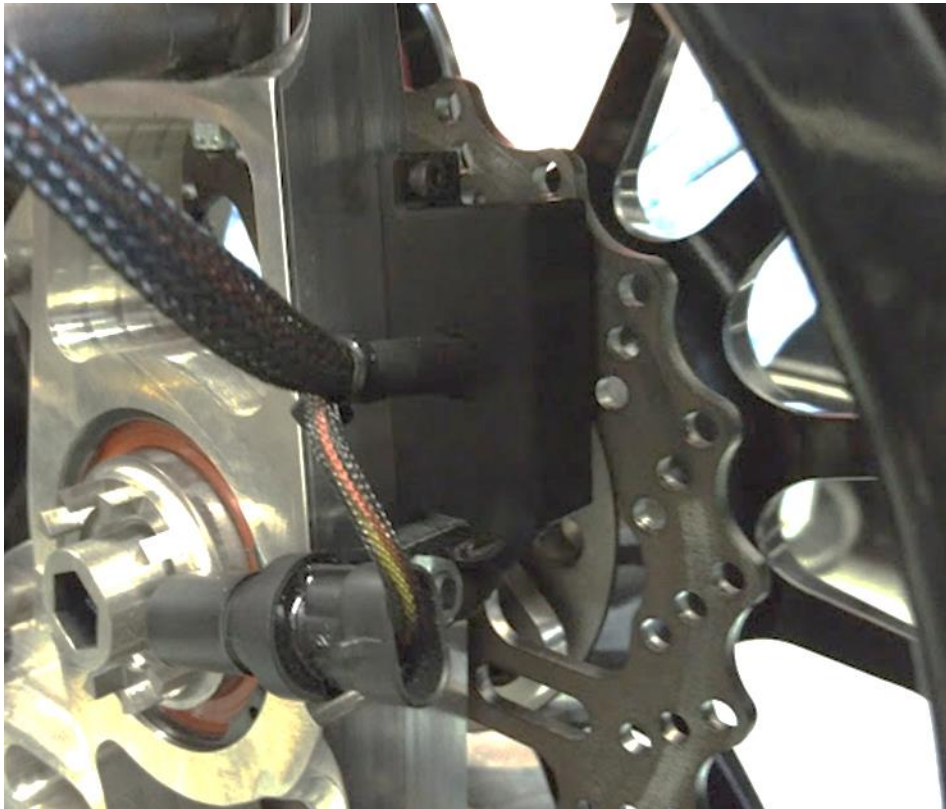

Figure 36: Wheel Board Mounting Location

One of the critical parameters to determine and control the dynamics of the vehicle is wheel speed. A wheel speed sensor allows for the measurement of each wheel speed, letting the tuners of the vehicle determine when and where the wheels are slipping. This also allows for tuning of brakes because brake lock can be detected by sensing which wheels stop moving. Having wheel speed sensors also allows for some vehicle dynamics controls. The restriction of FSAE rules limits the control of vehicle dynamics to cutting engine power when there is a significant slip in the rear two wheels. The wheel speed and steel tooth wheel can be seen in the left half of Figure 36. The wheel speed sensor is a Hall Effect sensor made by CHERRY that signals when the teeth of the toothed gear pass in front of it.

The last sensor on the connected to the wheel board is the suspension position sensor. This sensor is mounted on the suspension rocker and measures the deflection of the suspension. The position sensor allows for the selection of spring stiffness and damper settings, which allow for the control of body roll during cornering, dive during braking, and the general feel of the vehicle during straights. To measure the deflection of the suspension an analog rotary encoder described in the Rotary Position Sensor section in the Background chapter was mounted on the stationary shoulder bolt that the rocker pivots on. A PCB arm with a permanent magnet is mounted to the rocker and moves above the magnetic sensor.

All four sensors for the wheels are controlled by the microcontroller on the wheel board, which aggregates the sensor data and then sends it over CAN bus to the Main board. The block diagram for the wheel board is shown in Figure 37. The microcontroller on the wheel board was selected to be an ARM cortex M4 from TI described in the MSP432 section of the Background chapter. The MSP432 was selected because the requisite peripheral interfaces to communicate with all of the sensors simultaneously, as well as enough processing power to implement digital filter on the collected data if necessary. The MSP432 was also selected for ease of programming, this is because the microcontroller can be programmed using the Energia IDE which is easy to use, and free with no compiler limits. The Energia IDE also allowed the leveraging of Arduino libraries for certain sensors such as the TMP1006 infrared temperature sensor used for measuring brake temperature. The wheel board also includes two linear regulators to step down the 12V bus voltage to 3.3V and 5V used for the sensors on the board. The last system the board includes an SPI to CAN converter, allowing the main microcontroller to communicate to the main CAN bus on the vehicle.



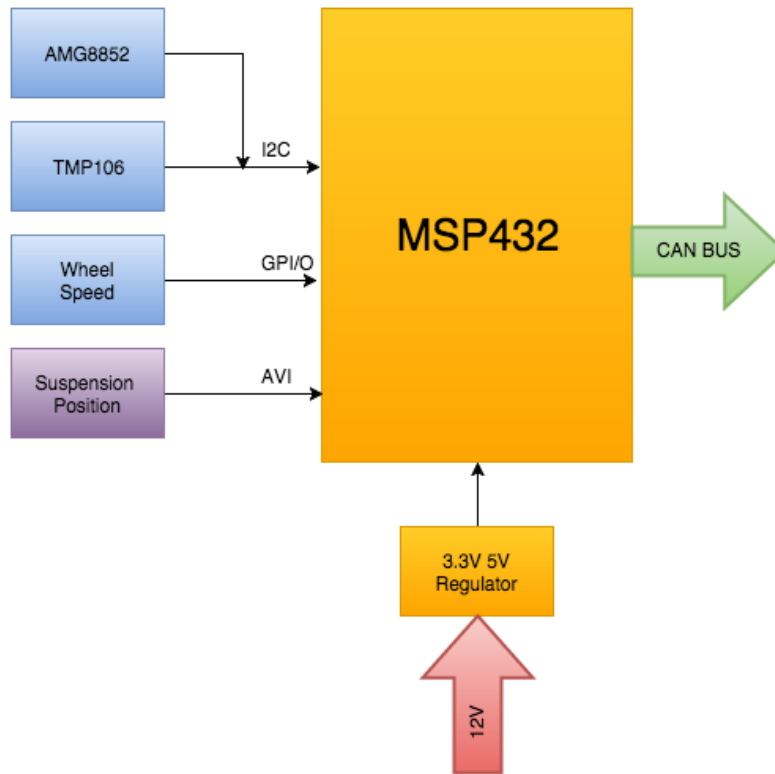

Figure 37: Wheel Board Block Diagram

### Steering Wheel Design

In modern open wheel racing like Formula 1 the steering wheel like the one in Figure 38 is not just used to control the vehicle's steering, it is also used to display vehicle telemetry and give the driver quick access to vehicle controls. The steering wheel for the WPI's vehicle was designed using this methodology of one central place for information and control. This section details the operation and design of the steering wheel for the vehicle.



Figure 38: Formula 1 Steering Wheel

The first major design constraint of the wheel is that the whole module must be detached from the vehicle through a quick release connection to allow the driver to exit the vehicle within 5 seconds during the egress test. The fast-paced egress test limits how the steering wheel can be electrically connected to the vehicle because if an extra connector is needed along with the quick release, the driver may take too long to exit the vehicle. For this reason, the electrical connection was designed to disconnect along with the mechanical quick release. There are electrical quick releases on the market that have this feature but they cost in excess of \$500, which was outside of the affordable range. Instead, a custom connector had to be made to interface the wheel and vehicle. The interface, shown in Figure 39, was designed to fit into the current quick release and is designed to be connected in any orientation. The design used pogo pins mounted in plastic that interface with a PCB with circular contacts shown in Figure 40, Figure 41, and Figure 42.

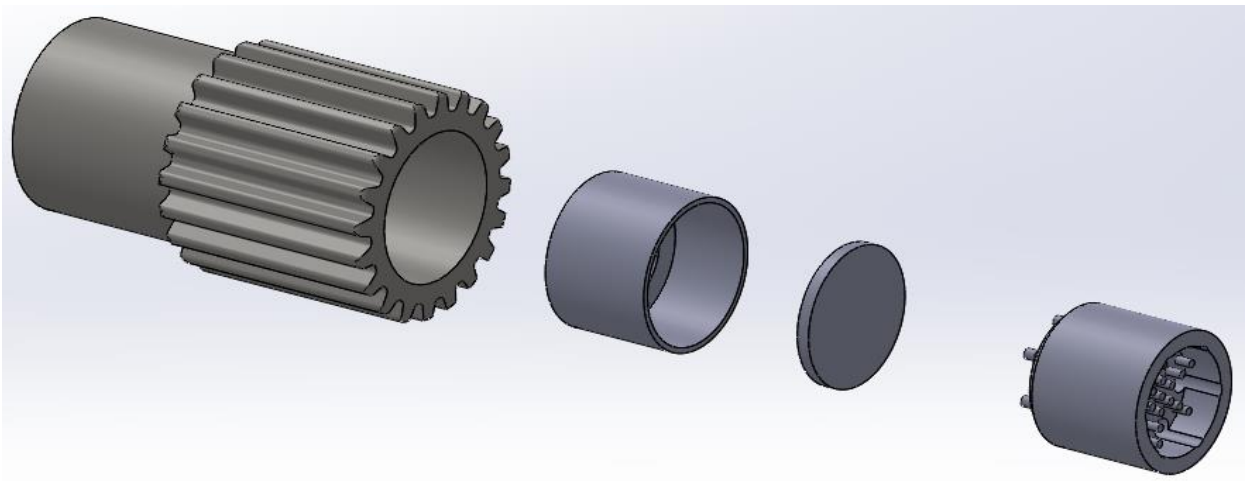

Figure 39: Electrical and Mechanical Quick Disconnects



Figure 40: Electrical Quick Disconnect Contacts

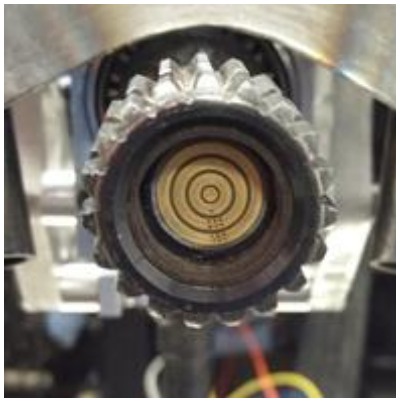

Figure 41: Vehicle Mounted Electrical Contact



Figure 42: Steering Wheel Mounted Electrical Contact

The next area of design is the way in which the display conveys information to the driver. Many possible display technologies could have been used to display information to the driver such as OLED LCD and LED. The previous steering wheel seen in Figure 43 used a large LCD display and while it was easily programmable and functional indoors, it was difficult to see the display in sunlight. The screen being

washed out in sunlight made it essentially useless on track and while there are LCD displays that are daylight readable, they are either too expensive or are difficult to get in one-off quantities making them not a viable choice for the wheel. The main advantage of using an LCD-like display, versus an LED display, is the availability of small form factor, high-resolution displays that are inherently able to display large amounts of vehicle telemetry data quickly. This influenced the inclusion of a small OLED screen on the bottom of the wheel as seen in Figure 44. OLED is easy to read in sunlight due to its higher contrast than LCD displays and is inexpensive in the size and resolution need, making it the best option for displaying information to the driver in varying lighting conditions.



Figure 43: 2015 Vehicle's Steering Wheel

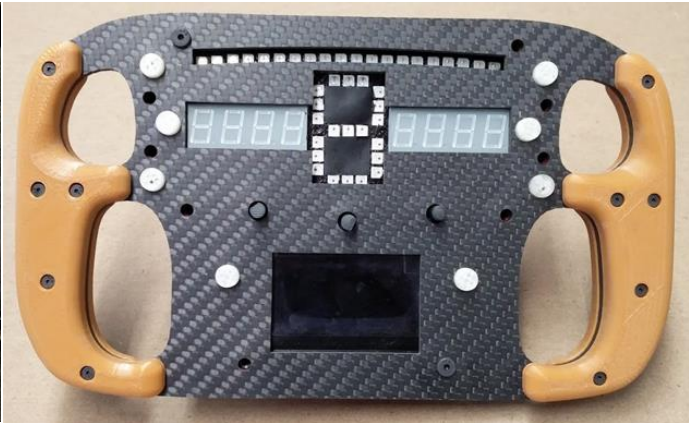
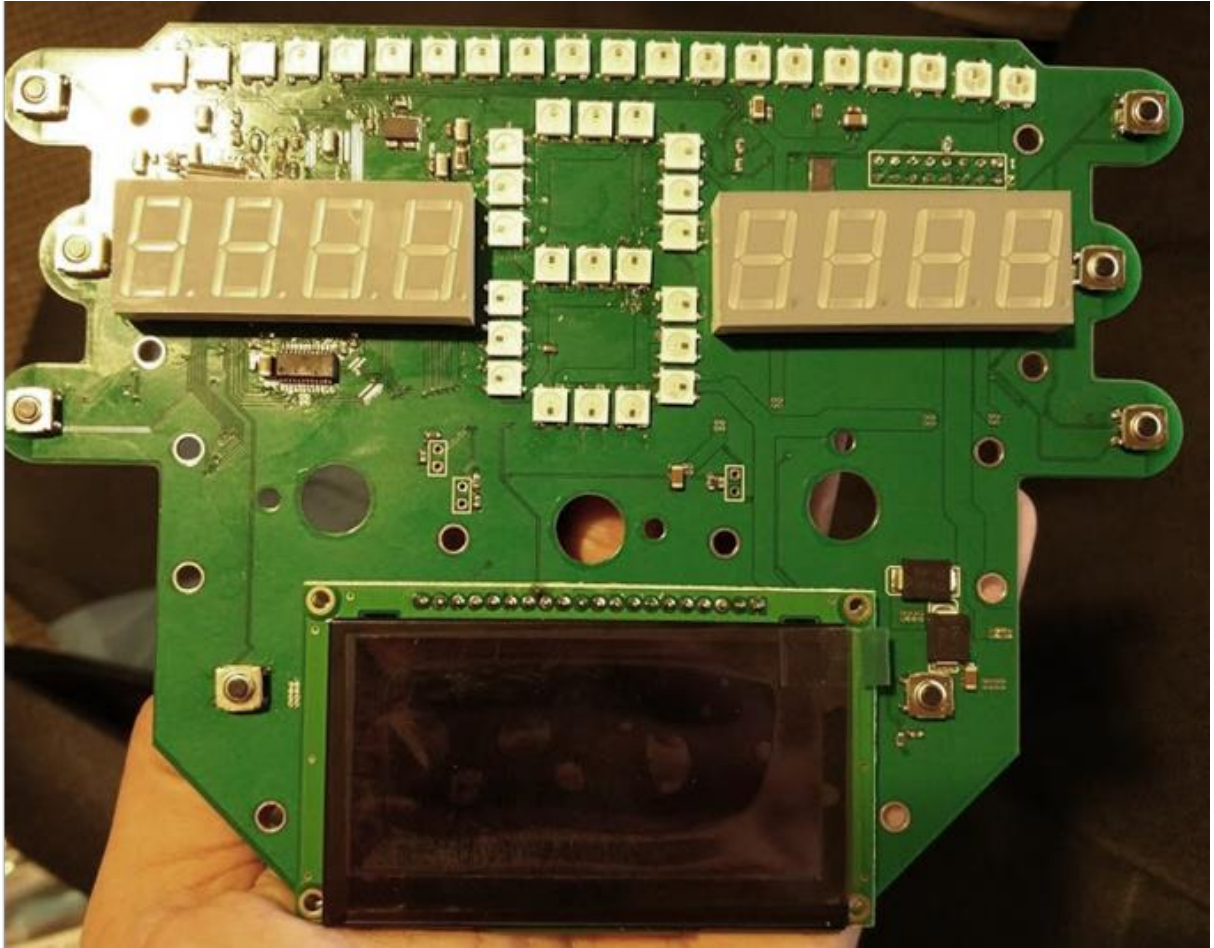

Figure 44: 2016 Vehicle's Steering Wheel

For the main display of RPM, speed, gear, and shift indicator an OLED display would have been too expensive for the size required to make the display easily visible to the driver. This narrowed the selection of display technology to LED. For the RPM and speed display a standardized 4x7-segment numeric high brightness display was chosen, which is driven by an i2c display driver. The generic seven-segment display footprint allows for the selection of different color display modules to best match the theme of the rest of the vehicle. The selection of a standardized display also allows for the selection of an easy to use display driver, in this case the AS1115. The display driver is one of the few that operates at 3.3V, or the logic level of the microcontroller, and has full brightness control. The AS1115 also has the advantage of a simple programming interface using I2C with simple commands to change the characters on the display and brightness. While this kind of display works well for the RPM and speed display, its size and single color limitations make it a non-viable option for the shift and gear display.



*Figure 45: Steering Wheel PCB*

The non-standardized nature of the gear display created the need to design a custom display using discrete LEDs that can be seen in the top of Figure 45. The largest area of complexity in the gear display is driving the LEDs as there are 40 RGB LEDs used in the gear and shift display. The LEDs could have been driven using either a custom or off the shelf constant current led driver but this would have been very complex as there are 120 individual LEDs, meaning there would need to be 120 drivers in the small footprint of the steering wheel PCB. To solve this problem, WS2812B daisy chainable LEDs are used. These LEDs are one package with red green and blue LEDs with included LED drivers and logic circuits. The LED modules operate by passing along a serial data stream from a microcontroller down the daisy chain that sets the RGB values for each LED module in the chain shown in Figure 46. The first LED module in the chain saves the first 24-bit data value from the microcontroller in an internal latch and then passes through each successive data value to the next LED module. The next LED module saves the first 24-bit value it receives and then retransmits any other values received, and so on down the chain. The values stored in each LED module are then used to set the internal LED drivers, reducing the complexity and footprint of the 40 RGB LEDs on the steering wheel board.

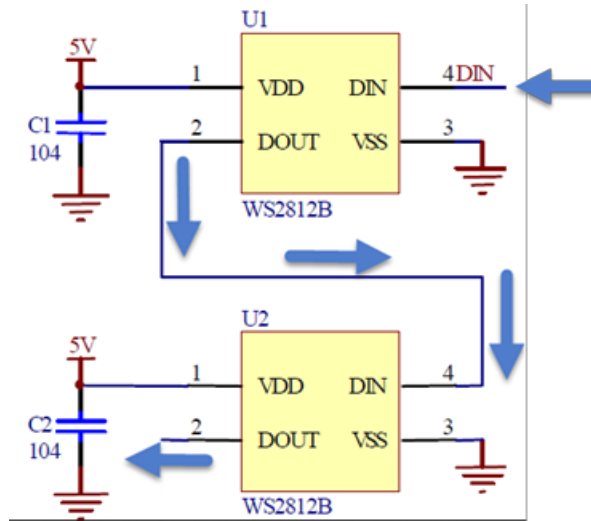

Figure 46: WS2812B LED Module Operation

Driving all of the displays on the steering wheel while simultaneously taking in button inputs and communicating over CAN bus requires a capable microcontroller. The steering wheel uses two microcontrollers, an MSP432 and an MSP430. The block diagram for the wheel board is shown in Figure 47. The MSP432 is used to take in all of the button inputs and send data to the OLED speed and RPM display. The MSP432 is also handles CAN bus communication with the rest of the vehicle, as well as managing the steering wheel power supplies. While the MSP432 could be used to drive the gear and shift display, the nature of the communication protocol means that the microcontroller would be spending the majority of its time sending data to the displays, which could potentially create a noticeable lag in button presses and display updates. For this reason, the MSP430 microcontroller is used to drive this display.

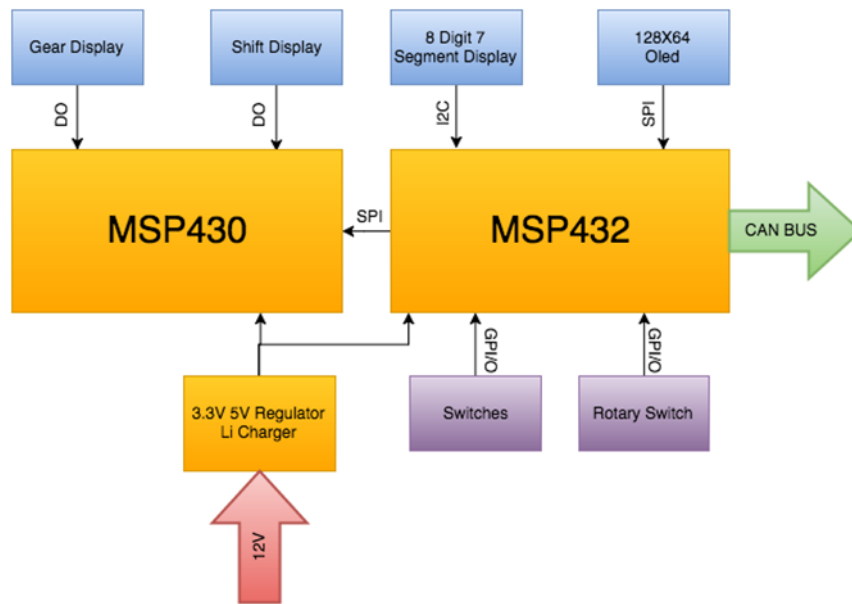

Figure 47: Steering Wheel Block Diagram

## Aerodynamic Sensors

One of the most important areas of vehicle performance is aerodynamic performance. A successful “Aero Package” can reduce drag on the vehicle and increase downforce allowing for greater cornering speeds. Typically, an aero package is designed in CFD (computational fluid dynamics) software and then verified using a wind tunnel. The area of focus for aero on the 2016 vehicle is the under tray, specifically creating an under tray that takes advantage of ground effect, which reduces the drag on the vehicle and is represented in Figure 48. To verify the functionality of the under tray, air pressure sensors were needed at multiple locations on the under tray.

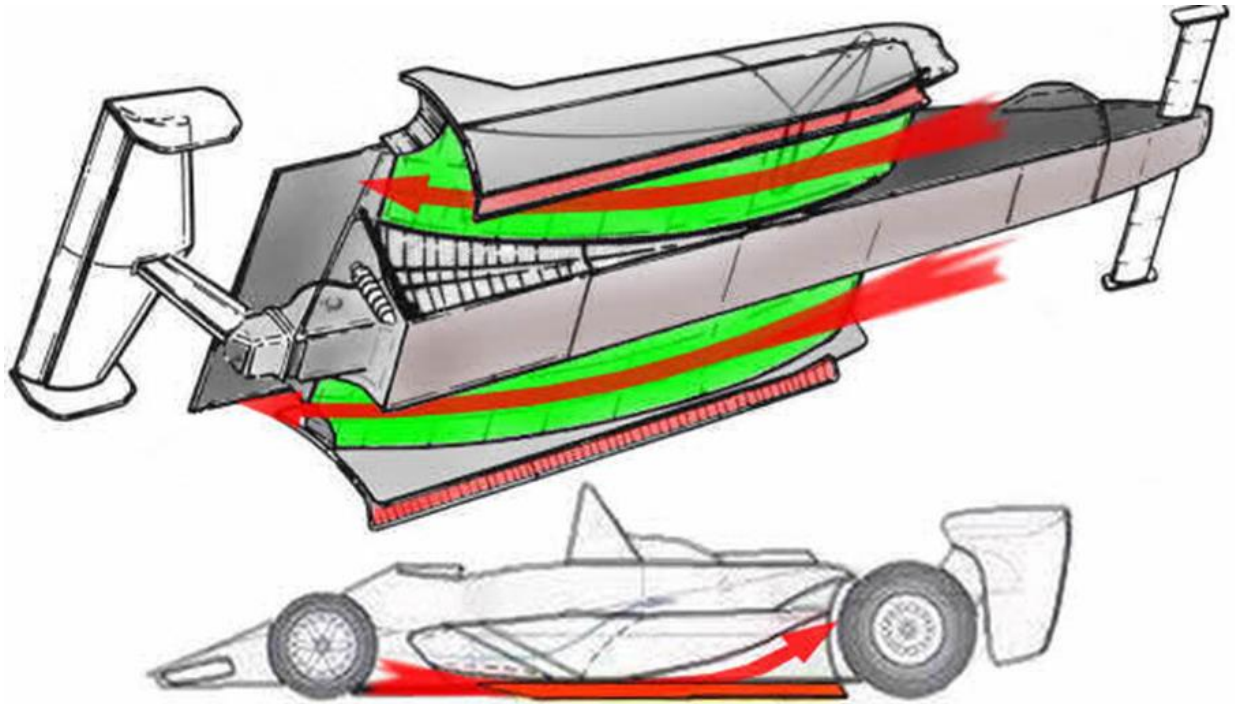
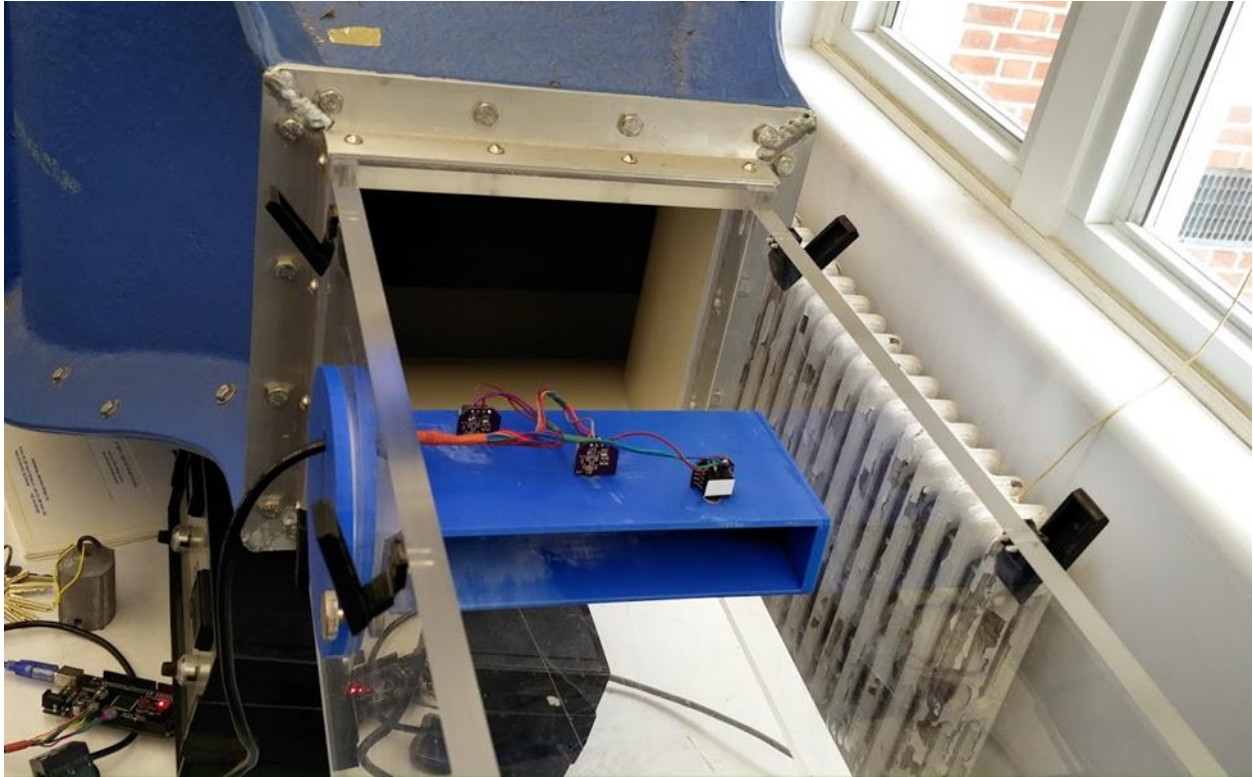

Figure 48: Ground Effect on an Under Tray

To sense the air pressure at points along the body the MPXV7002DP MEMS based pressure transducer was used, which is described further in the Air Pressure Sensor section of the Background chapter. The MPXV7002DP operates from 2kpa to -2kpa which is in the required range to measure the anticipated pressures applied to the under tray. The sensors are mounted on their own individual PCB with onboard power regulation. The sensor modules are then embedded into the under tray and the analog signals are sent to the Main board where they are sampled. Support for 20 sensors has been designed in to allow for the measurement of as many points on the under tray as needed. The test of this system in a wind tunnel can be seen below.



*Figure 49: Air Pressure Sensor Testing in a Wind Tunnel with Test Airfoils*

### Wireless Telemetry Pit Computer

Modern racing vehicles have constant wireless links to the pit. This link allows the pit crew to communicate with driver, informing them of changing track conditions, flags from the stewards, or collection and visualization of live data for tuning and troubleshooting purposes. Three main types of communication are useful for a race. The first is data from the sensors on the vehicle, second is live video from the vehicle, and third is an audio link with the driver. This section of the report discusses the communication schemes and modules selected to perform these tasks, as well as the software written for the pit computer to visualize the data.

The vehicle collects numerous parameters about itself, and all of these need to be transmitted to the pit computer. To calculate the data rate need for the wireless link, all of the sensors on the vehicle and their update rates were added to a spreadsheet shown in Figure 50.

Item	QTY	Notes	Size of packet(BYTES)	Update rate/s	Byte/s	Bit/s	Total Byte/s	Total Bit/s
RPM	1	1 2 Byte Number	2	10	20	160	1120	8960
Speed	1	1 1 Byte Number	1	10	10	80		
Air Fuel Ratio	1	1 2 Byte Number	2	10	20	160		
LOAD	1	1 1 Byte Number	1	10	10	80		
Gear	1	1 1 Byte Number	1	4	4	32		
Bat volt	1	1 1 Byte Number	1	1	1	8		
pneumatics state	1	1 2 Byte Number	2	4	8	64		
tire temp	4	4 4 Byte Number	16	10	160	1280		
Suspension	4	4 1 Byte Number	4	10	40	320		
Steering	1	1 2 Byte Number	2	10	20	160		
Throttle%	1	1 1 Byte Number	1	10	10	80		
Brake temp	4	4 1 Byte Number	4	10	40	320		
Aero load	8	12 1 Byte Number	96	4	384	3072		
Coolant Temp	1	1 2 Byte Number	2	4	8	64		
Air Temp	1	1 1 Byte Number	1	4	4	32		
Oil Pressure	1	1 1 Byte Number	1	4	4	32		
MAP	1	1 1 Byte Number	1	10	10	80		
Boost	1	1 1 Byte Number	1	10	10	80		
Fuel Flow	1	1 1 Byte Number	1	1	1	8		
ACCEL	1	3 1 Byte Number	3	10	30	240		
GYRO	0	3 1 Byte Number	3	10	30	240		
Wheel speed	4	4 1 Byte Number	4	10	40	320		
AUX TEMP	10	20 1 Byte Number	20	4	80	640		
GPS	1	2 4 Byte Number	8	2	16	128		
Batt Current	1	2 4 Byte Number	8	10	80	640		
Aero Pressure	12	2 4 Byte Number	8	10	80	640		

Figure 50: Wireless Data Rate Calculation

The result was that the wireless transmission scheme used needs to be able to transmit at a minimum rate of 9600 baud. The next parameter is the range at which the transmitter needs to transmit across. This can be found by measuring the farthest distance the transmitter would need to transmit across, which was measured to be 700m according to the map of the competition grounds in Figure 51. With a minimum distance of 700m, the XTend 900 wireless module was selected as seen in Figure 52. This module supports a data rate of 57 kbaud with a range of up to 40 miles. Alternative radios like the XBee did not have enough range for this application.





Figure 51: Farthest Transmission Distance at Competition



Figure 52: XTend 900MHz Transceiver

All of this data needs to be displayed and processed in a way that produces meaningful data that can allow for design changes and tuning. This will all be done through the pit computer GUI. The pit computer GUI is designed in a program called Processing and connects to the vehicle over the wireless data link. The screen in Figure 53 shows the live vehicle telemetry screen. On the screen there are tire temperature, brake temperature, suspension position, steering position, accelerator position, and brake position displays. The software also has the capability of recording data to a CSV file for later processing. The software can also give a race engineer real time information on problems with the vehicle that may need to be fixed.

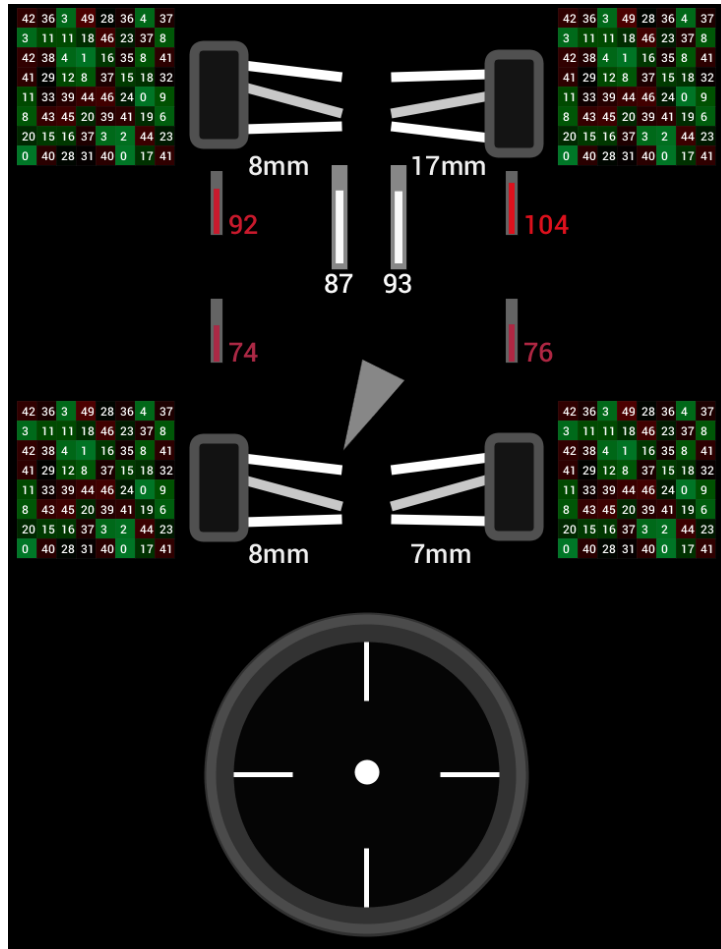

Figure 53: Pit Computer GUI

Along with data telemetry, the vehicle also features audio and video telemetry shown in Figure 54. For both of these functionalities the existing systems are common and low cost. For the audio system, the RF SA858 4W UHF walkie-talkie module is used with a motorcycle helmet headset mounted in the driver's helmet. This module has the advantage of using a standardized, unlicensed frequency that most walkie-talkies can use, making it easy to communicate with the vehicle. For the video telemetry there are many off the shelf modules used for FPV (first person view) systems that can be used. The vehicle uses a generic module that operates at 1.2GHZ and has a range of 5km.

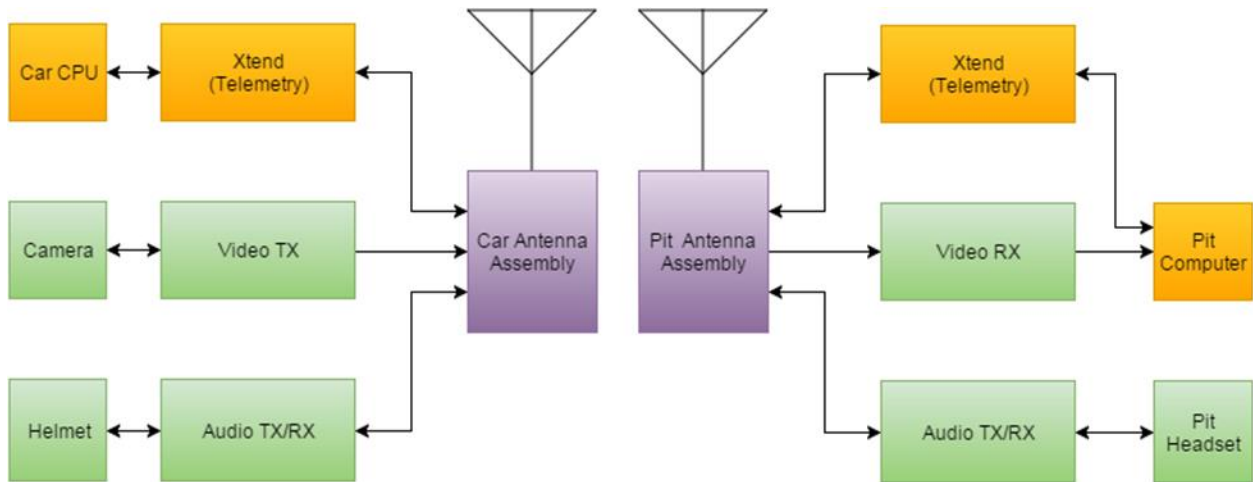

Figure 54: Wireless Communication Diagram

All three telemetry systems need antennas at both ends of the data links. The antennas for the pit have minimal restrictions on size and weight but the antennas for the vehicle required consideration of such factors. The vehicle's smaller antennas in Figure 55 are mounted in a 3D printed housing behind the driver's headrest. The antennas were placed to stay within the roll envelope of the vehicle to ensure they are not damaged in case of a crash. The pit computer's higher gain antennas shown in Figure 56 were mounted on a 4-foot PVC pole that was then mounted to a 20ft pole attached to the trailer. The height of the pole ensures that the pit antennas are above obstacles on the track to allow for nearly perfect line of sight operation and for the highest signal strength.



Figure 55: Vehicle Mounted Antennas



Figure 56: Trailer Mounted Antennas

### Kill Switch Circuit and Controller interface

FSAE requires several electrical safety devices to ensure driver safety on track. FSAE requires an electronic stop switch that kills the engine when pressed and electrical power shut off switches that physically disconnect electrical power from the vehicle. Vehicles with electronic throttle and drive by wire are also required to include a device that kills the engine if the driver fully depresses the brakes while the accelerator pedal is depressed. This section will include the design and testing of these devices.

The electronic stop and battery disconnect are relatively simple devices. The placement of them on the vehicle can be seen in Figure 57 and Figure 58. The electronic stop operates by removing power from the relay that enables the fuel pump and spark plugs, thus killing the engine instantly. The battery cutoff operates by physically disconnecting the battery from the rest of the vehicle to ensure that the vehicle cannot start or crank.



*Figure 57: Electronic Stop Button*

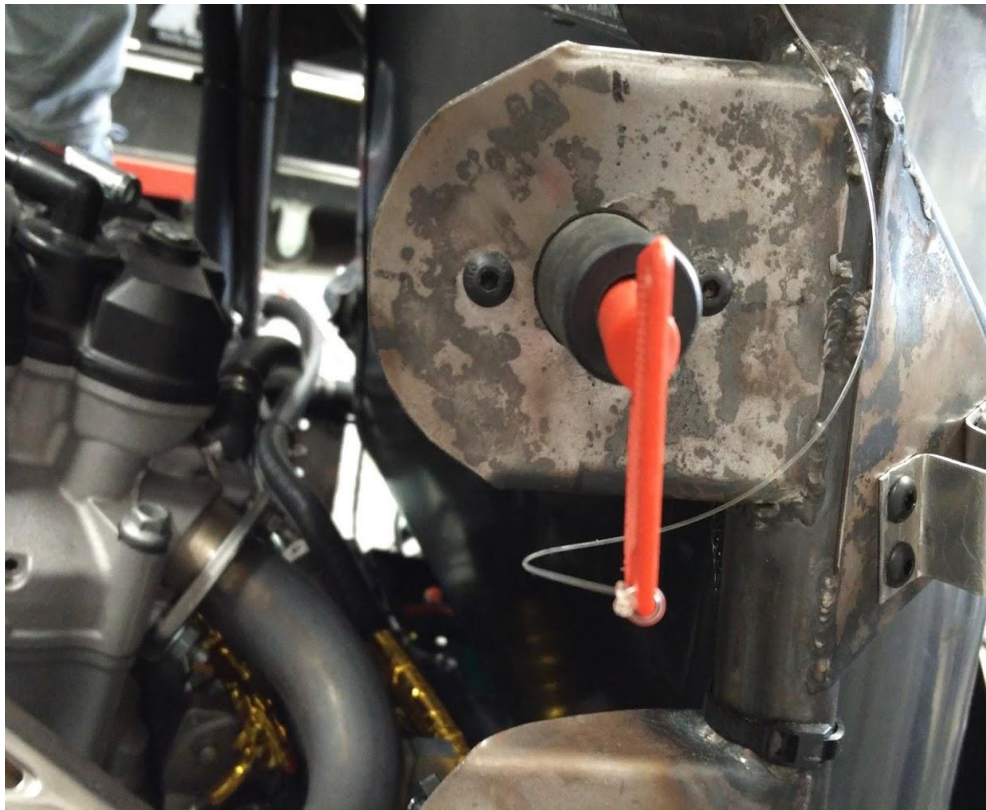

*Figure 58: Battery Disconnect Switch*

The electronic throttle safety device is more complex than the switches discussed earlier. FSAE requires that the device measures the accelerator and brake pedal position to ensure that the driver does not reduce both simultaneously and ensures that if the accelerator pedal were to malfunction, the vehicle will not experience unintended acceleration. The device is also required to disable the engine if any of the faults occur. The circuit, which can be seen below, operates by comparing the brake and accelerator pedal position values and trips a flip-flop if it detects an error condition. Because the flip-flop is clocked with the input pin, the output will latch on high.

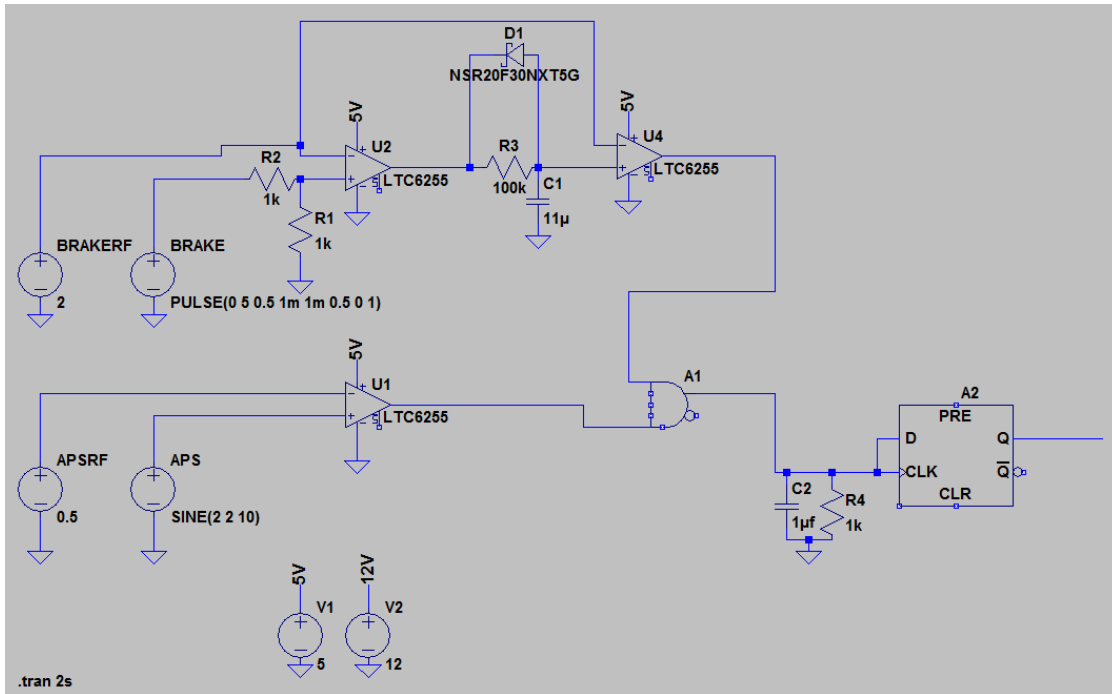

Figure 59: Electronic Throttle Safety Device

## Results

The dependency of the electrical senior design project on the mechanical senior design project means that if the vehicle is not running and driving then there is no way to confirm the operation of the electrical system. Unfortunately, the vehicle was held back by engine issues, pushing the mechanical senior design project schedule past the end date of the electrical senior design project. This means that the sensors were not tested on a running, driving vehicle and no confirmation could be made on the operation of sensors and electrical systems in the environment they were intended to operate in. While the sensors and electrical systems were not tested on the vehicle, they were bench tested to confirm basic operation.

The wireless system was tested at four times the required distance need for the competition. The wireless transceivers were able to communicate over a distance of 4km from the top of one hill to another shown in Figure 60. The hill-to-hill test closely matches the environment on the competition track at Michigan International Speedway, as the pit antenna is higher than the vehicle and there are little to no obstructions to line of sight communication between the vehicle and the pit antennas. The transceivers in the hill-to-hill test without using the high gain antennas that are used in the final system were able to communicate at the maximum data rate of 57600 baud that the modules support. This test confirms that the transceivers will work on track for the application intended as well as showing they can operate at the needed 9600 baud.

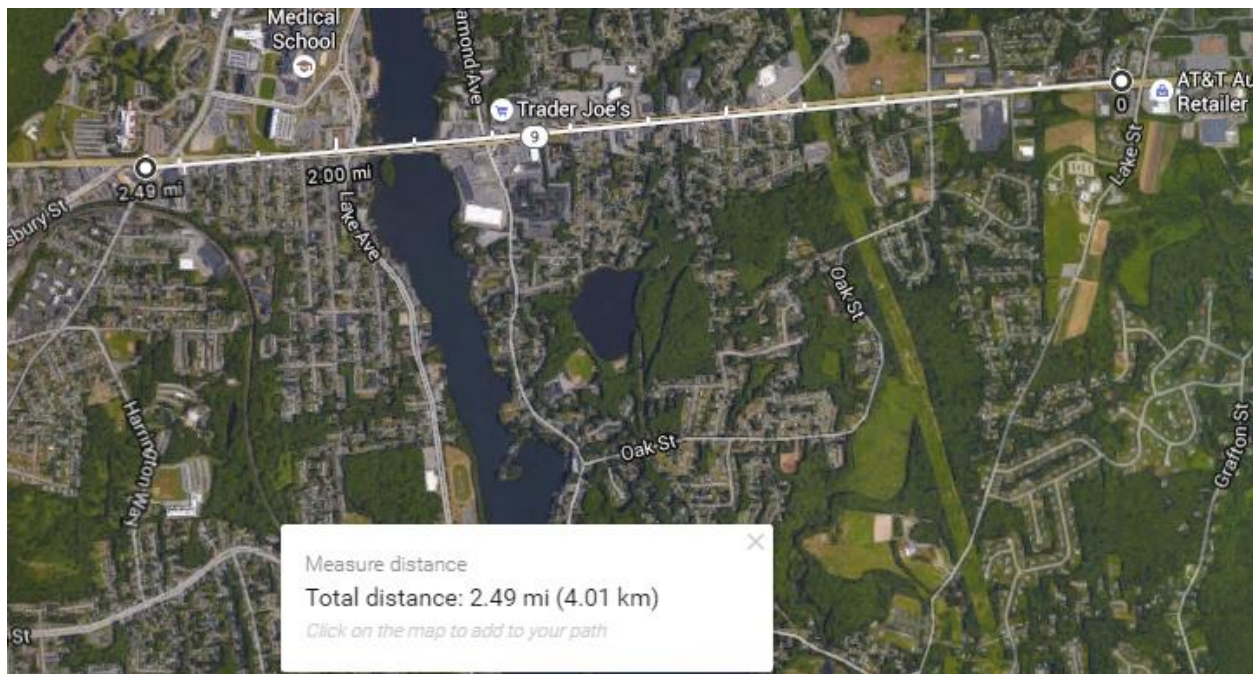
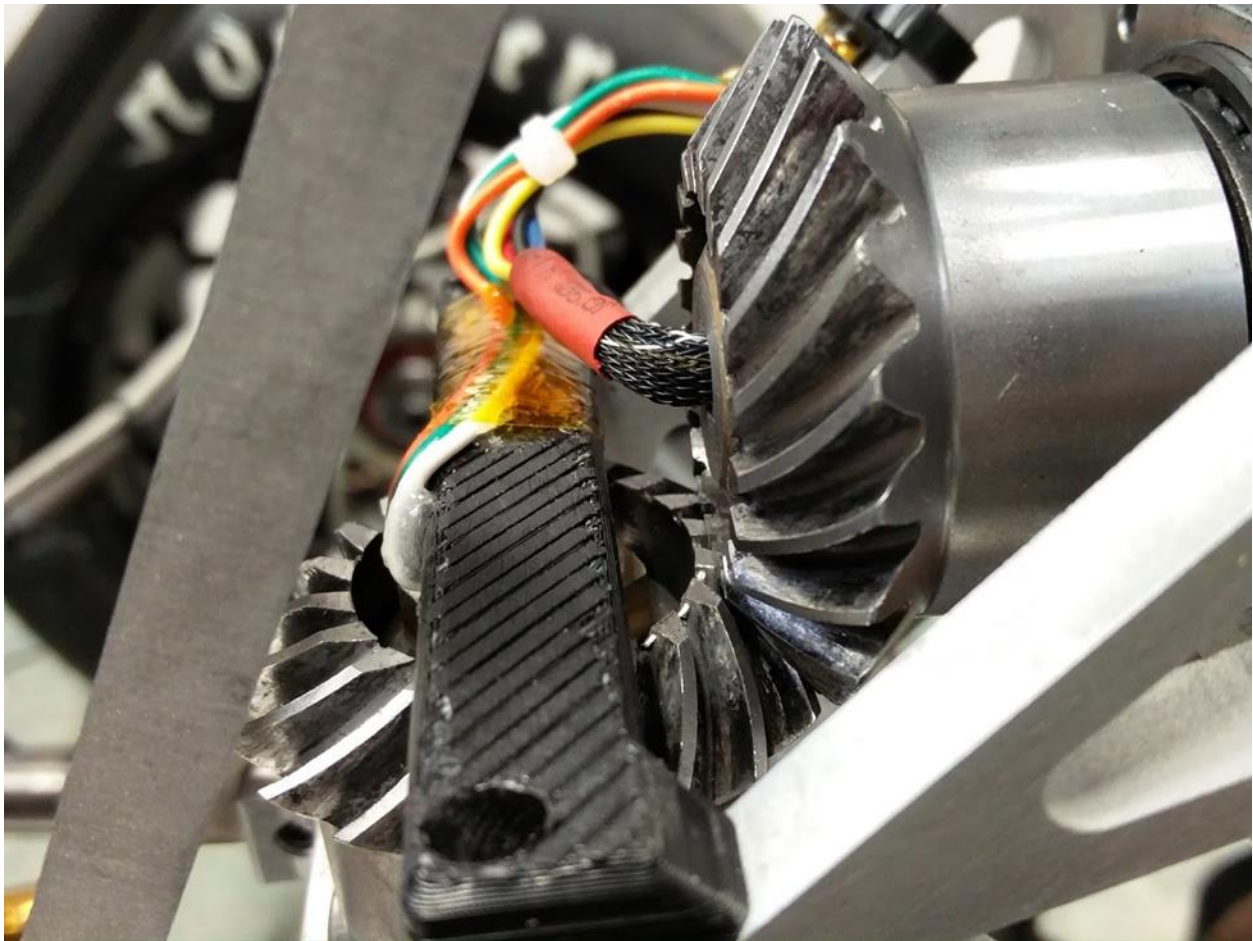

Figure 60: Wireless Transceiver Testing Location

Multiple sensors on the vehicle need to have confirmed operation before they can be integrated into the vehicle. The noncontact IR temperature sensors were tested by heating their respective targets like brake rotors and tires to operating temperatures and aiming the sensors at the surface of the target.

The steering and position sensor seen in Figure 61 was able to be integrated into the vehicle and was tested by measuring the full range of motion to ensure operation. The steering position sensor information was then used to confirm the operation of the suspension position sensors despite the fact that they were not able to be mounted because both systems use the same sensor configuration to measure their respective parameters. The final sensors that needed testing were the wheel speed sensors, which were tested by mounting them on the upright and spinning the wheel to confirm it could detect the toothed wheel mounted to the wheel bearing.



*Figure 61: Steering Position Sensor*

The framework of the pit computer software was tested when the air pressure sensors were tested. The aerodynamics designer used a wind tunnel to test the air pressure sensors on a sample wing piece and the data from the sensors were collected, processed, recorded, and displayed by the framework of the pit computer software. This test showed that the updating of gauges in the GUI and the recording of data to a CSV file works. This test also confirmed the communication scheme between the vehicle and the pit computer worked because the scheme used the wind tunnel setup and the vehicle are the same.



## Conclusion and Future Work

Two important functions of electronics and software in motorsport are to provide data for tuning and design of the vehicle and to enable driver interaction and aid systems. The system laid out in this report intended to provide these two functionalities for the 2016 vehicle. However, because both the vehicle and the electronics were designed and built within the course of one senior design project, there was limited time to test on track. This means that there was little use of the data collection system limiting its usefulness for tuning for the 2016 Formula SAE competition. The driver's aids were also affected by this lack of testing, while some like the automatic gearbox were finished in time. Despite setbacks, the 2016 Formula SAE Vehicle Electrical Systems Design senior design project was able to accomplish:

1. Electronic throttle
2. Electronically actuated shifting
3. Automatic gearbox
4. Wireless telemetry and data logging
5. Remote telemetry data display
6. Steering wheel information display and driver interface
7. Wheel data gathering
8. Aerodynamic data gathering

The value of the work done in this senior design project can be reaped in future years. The systems developed in this project can be improved and refined by subsequent project groups and can be implemented into vehicles that are based on the 2016 vehicle, giving more time for testing. Refinements and small changes made to the framework laid out by the 2016 vehicle can allow future vehicles to be much more competitive. Having a running vehicle with full telemetry early in the academic year can also improve the quality of driver by giving the drivers more time in the vehicle on track. It is for all of these reasons that it is suggested that future work in Formula SAE and in particular the electronics system should focus on refinement of the groundwork laid in 2016 rather than starting from the ground up.

## Appendix

### Schematic Table of Contents:

#### Main Board

- Top Level Schematic
- Main Logic
- ECU Interface
- Air Pressure Sensor Input
- Aerodynamic Surface Control Output
- Radio Interface
- Motor Controller
- Shift Controller
- Power Regulation

#### Wheel Board

- Wheel Board Schematic

#### Steering Wheel Board

- Main Logic
- Display Drivers
- LEDs
- Tactile Switch Interface
- Power Regulation

#### Steering Position Sensor Board

- Steering Position Sensor Schematic

#### Air Pressure Sensor Board

- Air Pressure Sensor Schematic

#### Pit Computer Radio Board

- Pit Computer Radio Schematic

## Main Board

- Top Level Schematic
- Main Logic
- ECU Interface
- Air Pressure Sensor Input
- Aerodynamic Surface Control Output
- Radio Interface
- Motor Controller
- Shift Controller
- Power Regulation

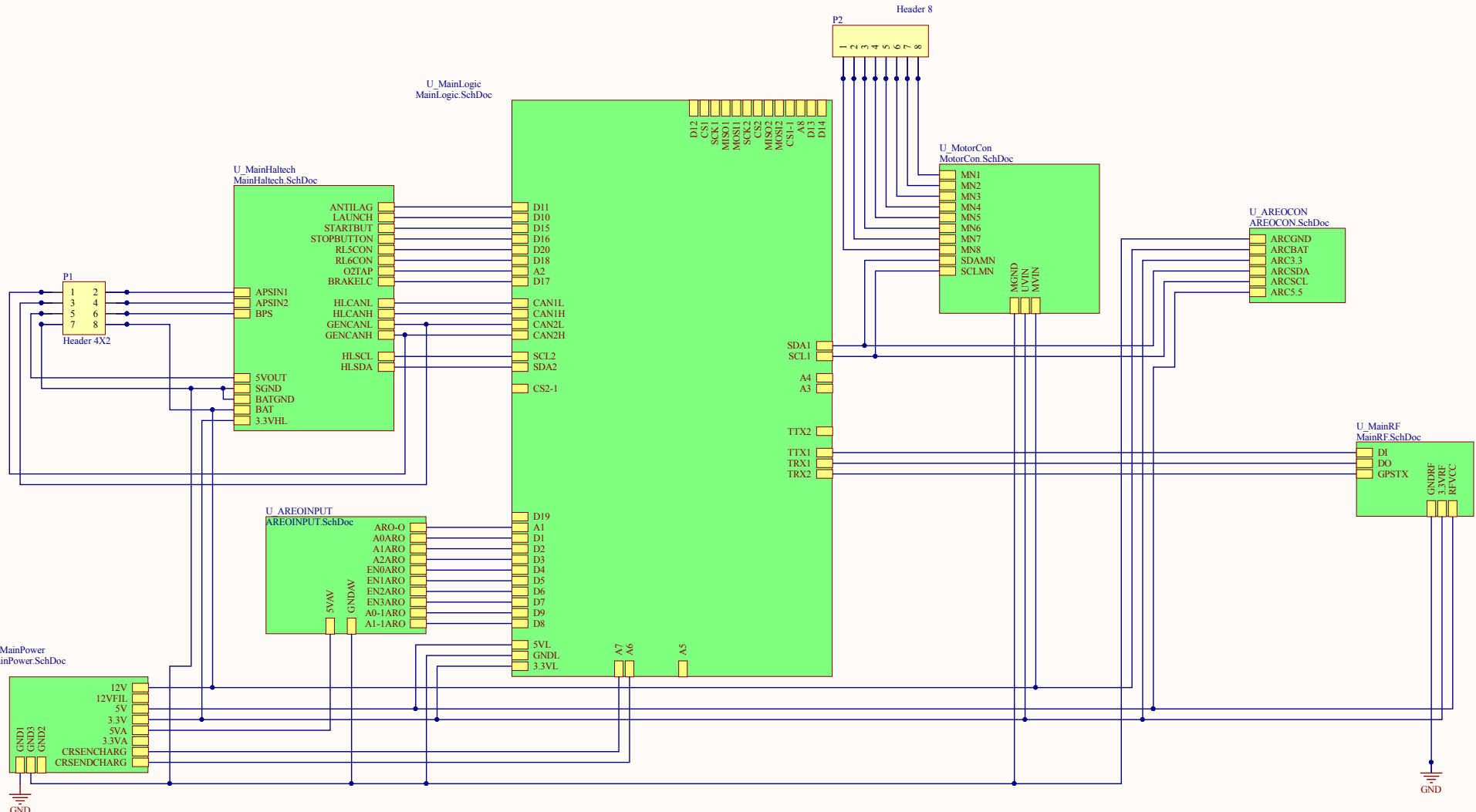

Title		
Size	Number	Revision
B		
Date:	12/2/2015	Sheet of
File:	C:\Users\Main.SchDoc	Drawn By:

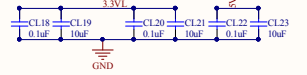
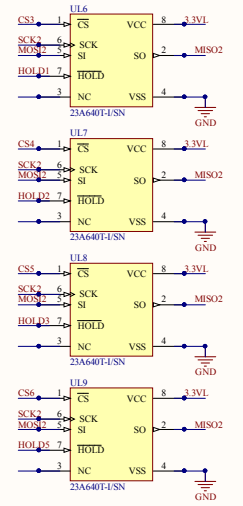
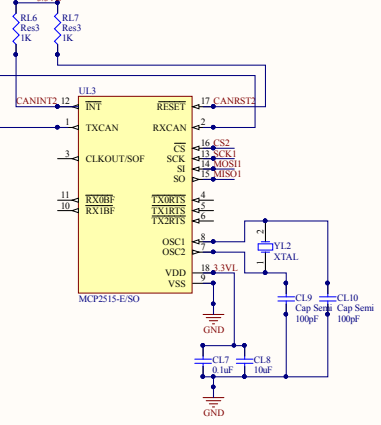
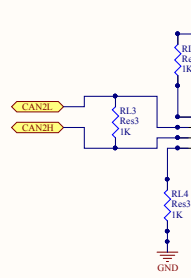
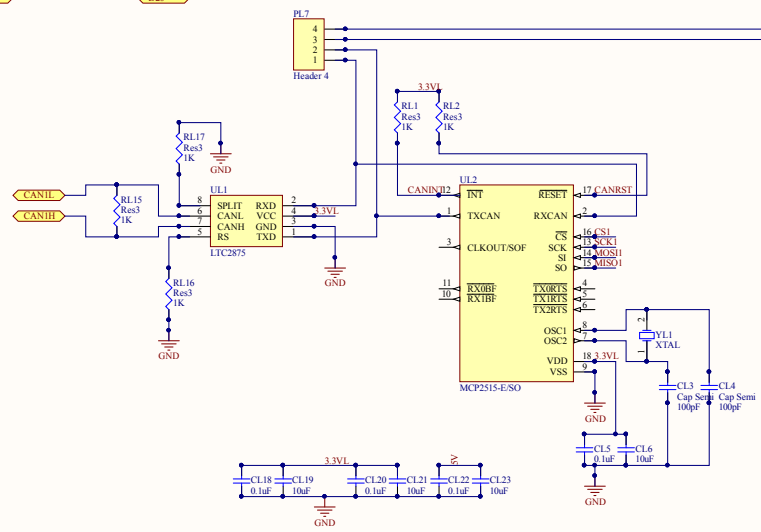
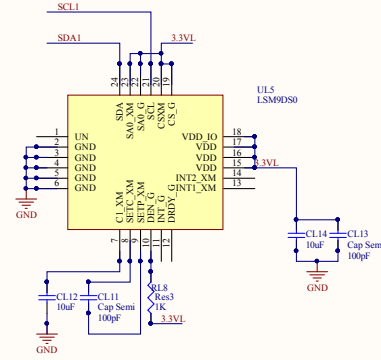
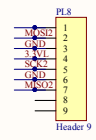
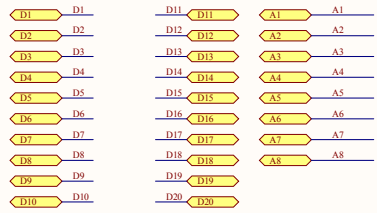
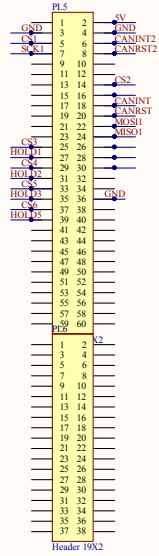
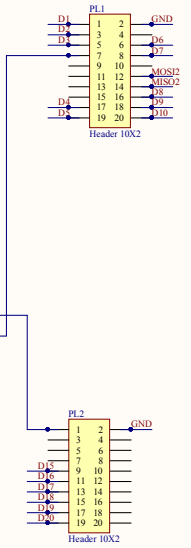
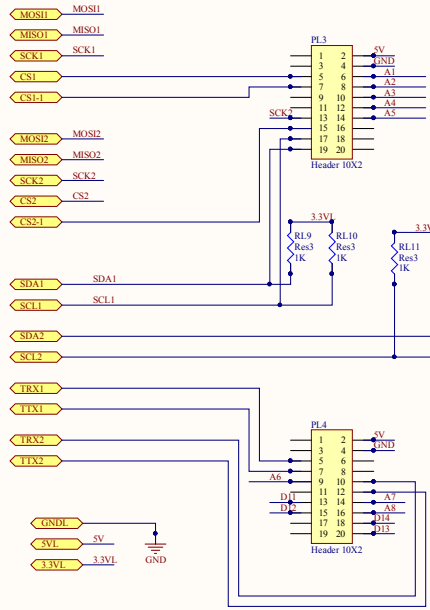

Title		
Size	Number	Revision
C		
Date:	12/2/2015	Sheet of
File:	C:\Users\...MainLogic_SchDoc	Drawn By:

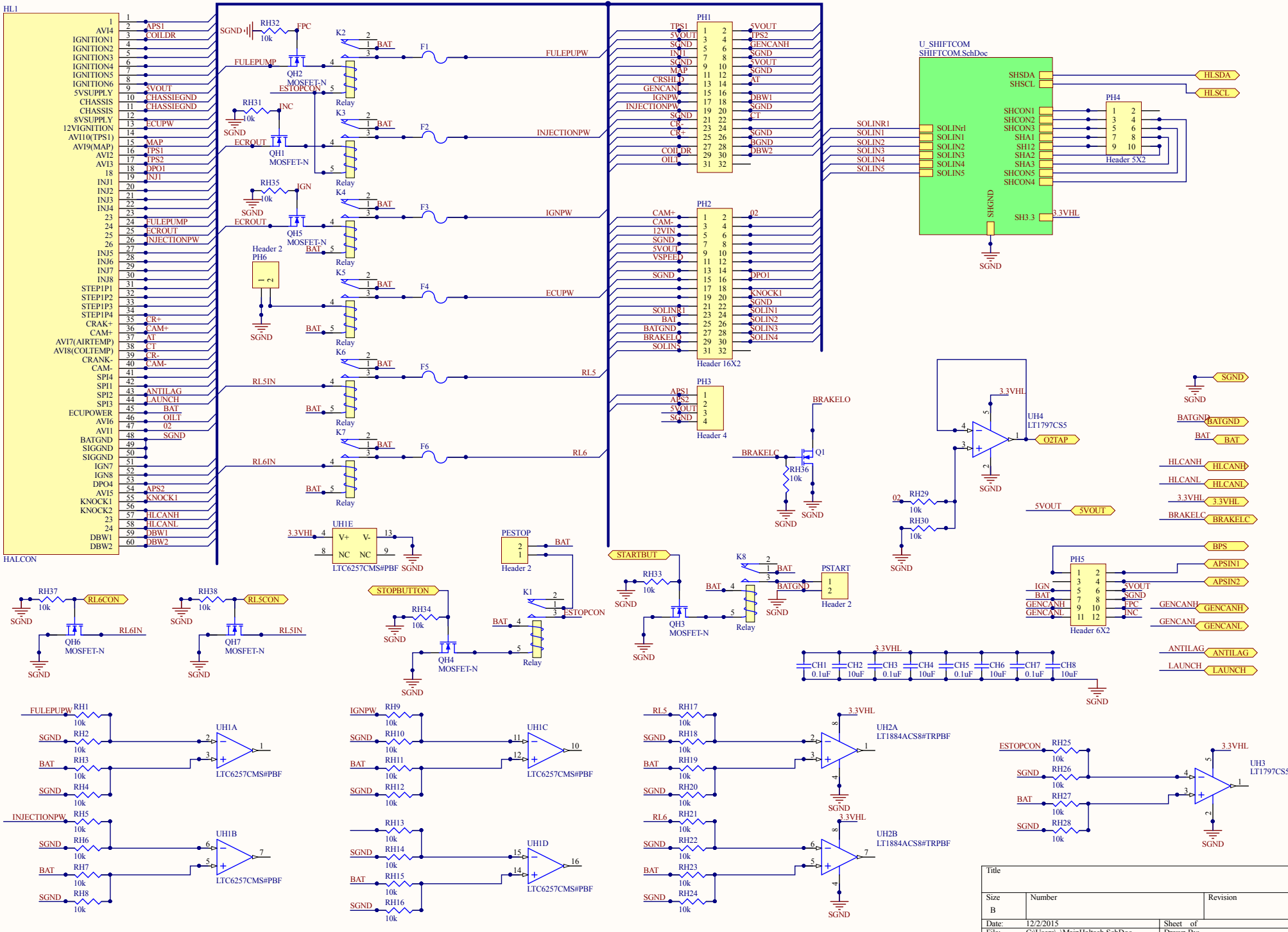

HL1  
 1 AV14  
 2 IGNITION1  
 3 IGNITION2  
 4 IGNITION3  
 5 IGNITION4  
 6 IGNITION5  
 7 IGNITION6  
 8 5VOUT  
 9 CHASSISGND  
 10 CHASSISGND  
 11 CHASSISGND  
 12 8VSUPPLY  
 13 12VIGNITION  
 14 AV10(TPS1)  
 15 AV19(MAP)  
 16 AV12  
 17 AV13  
 18  
 19 IN1  
 20 IN2  
 21 IN3  
 22 IN4  
 23  
 24 FULEPUMP  
 25 ECRROUT  
 26 INJECTIONPW  
 27  
 28 INJ5  
 29 INJ6  
 30 INJ7  
 31 INJ8  
 32 STEP1P1  
 33 STEP1P2  
 34 STEP1P3  
 35 STEP1P4  
 36 CRAK+  
 37 CAM+  
 38 AV17(AIRTEMP)  
 39 AV18(COLTEMP)  
 40 CRANK-  
 41 CAM-  
 42 SPI4  
 43 SPI2  
 44 SPI3  
 45 ECUPOWER  
 46 AV16  
 47 AV11  
 48 BATGND  
 49 SIGGND  
 50 SIGGND  
 51  
 52 IGN7  
 53 IGN8  
 54 DPO4  
 55 AV15  
 56 KNOCK1  
 57 KNOCK2  
 58 23  
 59 24  
 60 DBW1  
 61 DBW2

PH1  
 1 TPS1  
 2 5VOUT  
 3 SGND  
 4 TPS2  
 5 GENCANH  
 6 SGND  
 7 5VOUT  
 8 SGND  
 9 MAP  
 10 CRSHLD  
 11 12  
 13 AT  
 14 GENCANL  
 15 15  
 16 DBW1  
 17 SGND  
 18 INJPNP  
 19 19  
 20 CT  
 21 21  
 22 22  
 23 23  
 24 24  
 25 25  
 26 26  
 27 27  
 28 28  
 29 29  
 30 30  
 31 31  
 32 32

PH2  
 1 CAM+  
 2 CAM-  
 3 12VIN  
 4 SGND  
 5 5  
 6 6  
 7 7  
 8 8  
 9 9  
 10 10  
 11 11  
 12 12  
 13 13  
 14 14  
 15 15  
 16 16  
 17 17  
 18 18  
 19 19  
 20 20  
 21 21  
 22 22  
 23 23  
 24 24  
 25 25  
 26 26  
 27 27  
 28 28  
 29 29  
 30 30  
 31 31  
 32 32

PH3  
 1 APS1  
 2 APS2  
 3 5VOUT  
 4 SGND

PH4  
 1 SHCON1  
 2 SHCON2  
 3 SHCON3  
 4 SHA1  
 5 SH12  
 6 SHA2  
 7 SHA3  
 8 SHCON5  
 9 SHCON4  
 10 SH3.3

PH5  
 1 IGN  
 2 5VOUT  
 3 SGND  
 4 GENCANH  
 5 FPC  
 6 GENCANL  
 7 GENCANL  
 8 GENCANL  
 9 11  
 10 12

Title		
Size	Number	Revision
B		
Date:	12/2/2015	Sheet of
File:	C:\Users\N_Main\Haltech_SchDoc	Drawn By:

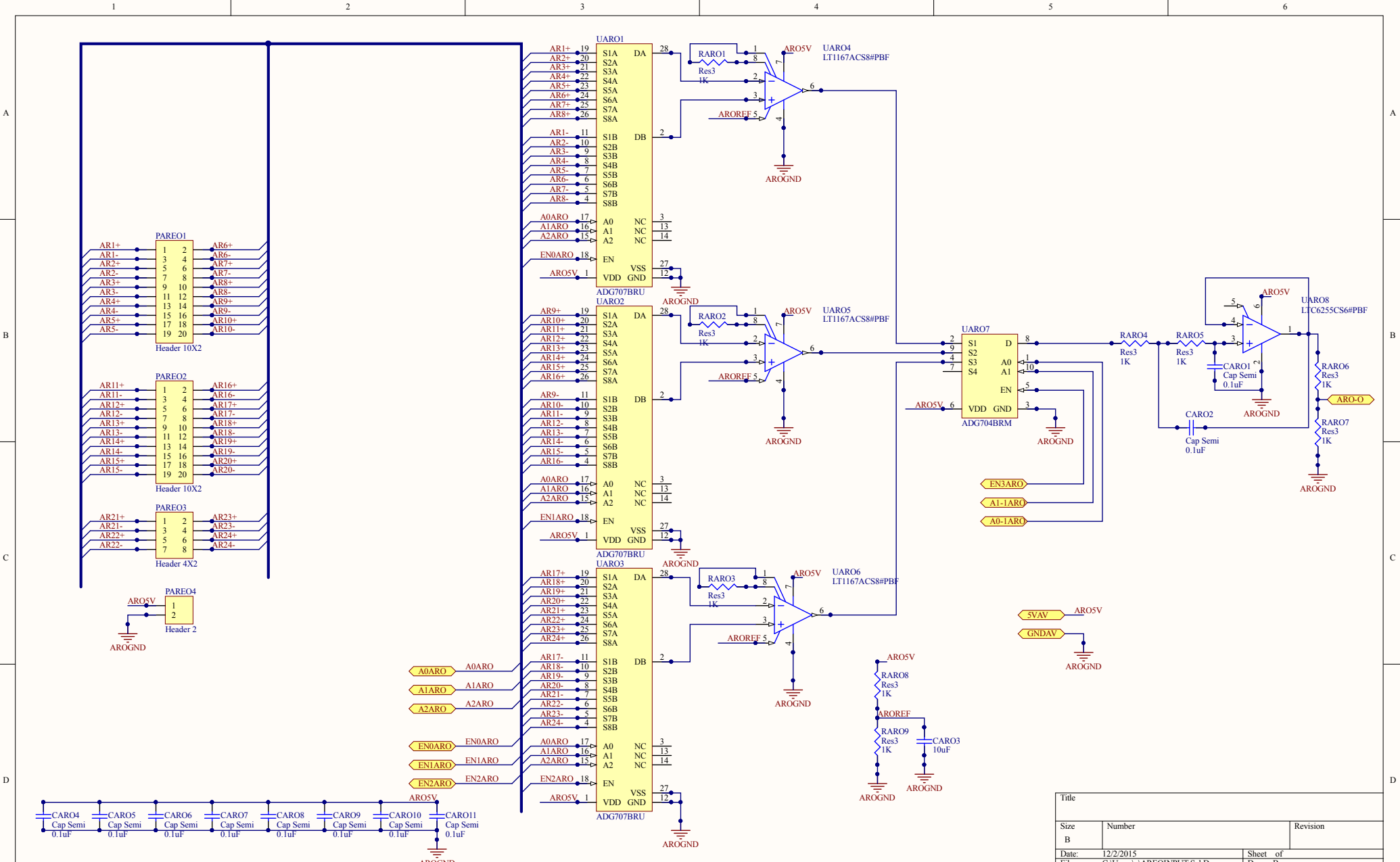

Title		
Size	Number	Revision
B		
Date:	12/2/2015	Sheet of
File:	C:\Users\... \AREOINPUT.SchDoc	Drawn By:

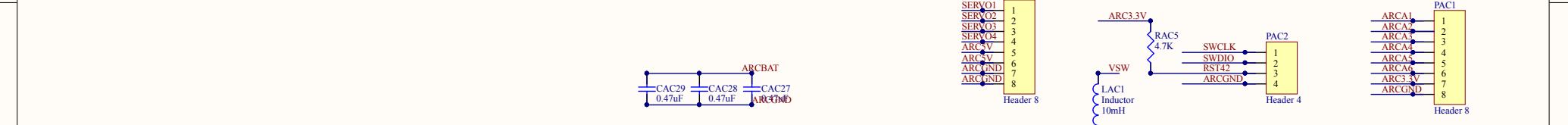
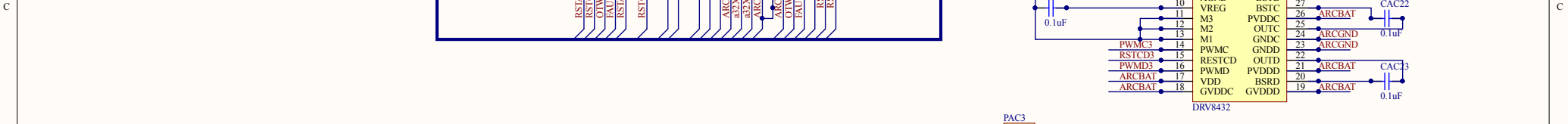
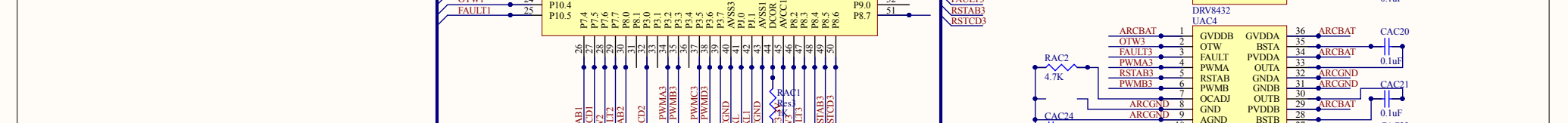
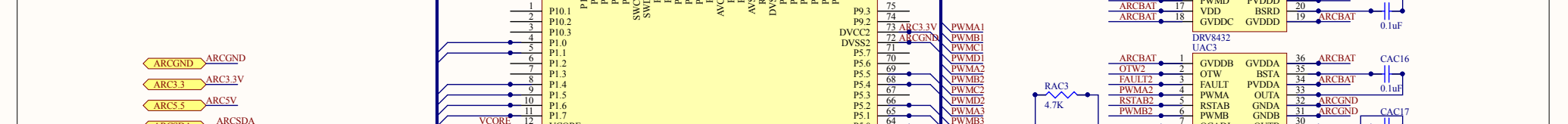
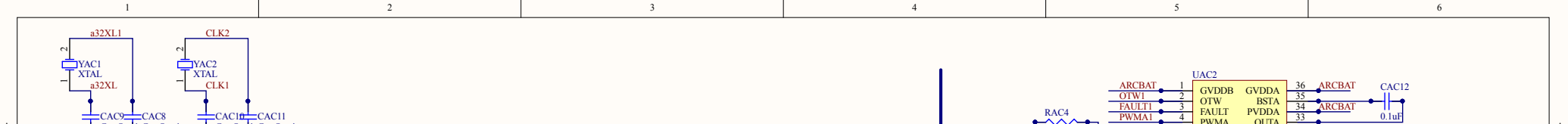

Size	Number	Revision
B		
Date:	12/2/2015	Sheet of
File:	C:\Users\... \AREFOCON.SchDoc	Drawn By:

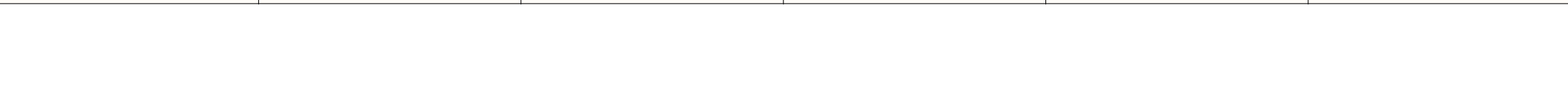



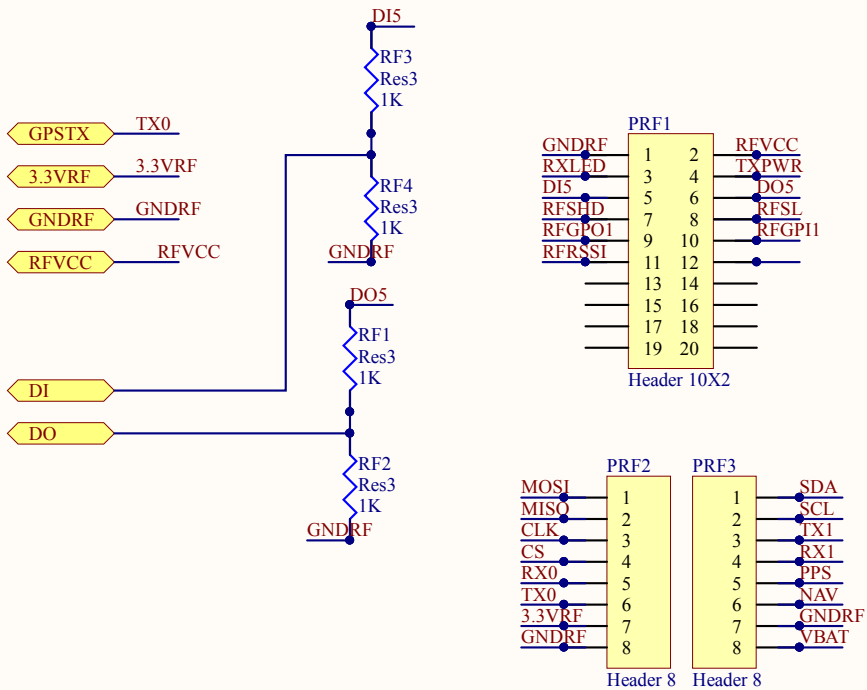

Title		
Size	Number	Revision
A		
Date:	12/2/2015	Sheet of
File:	C:\Users\...\MainRF.SchDoc	Drawn By:

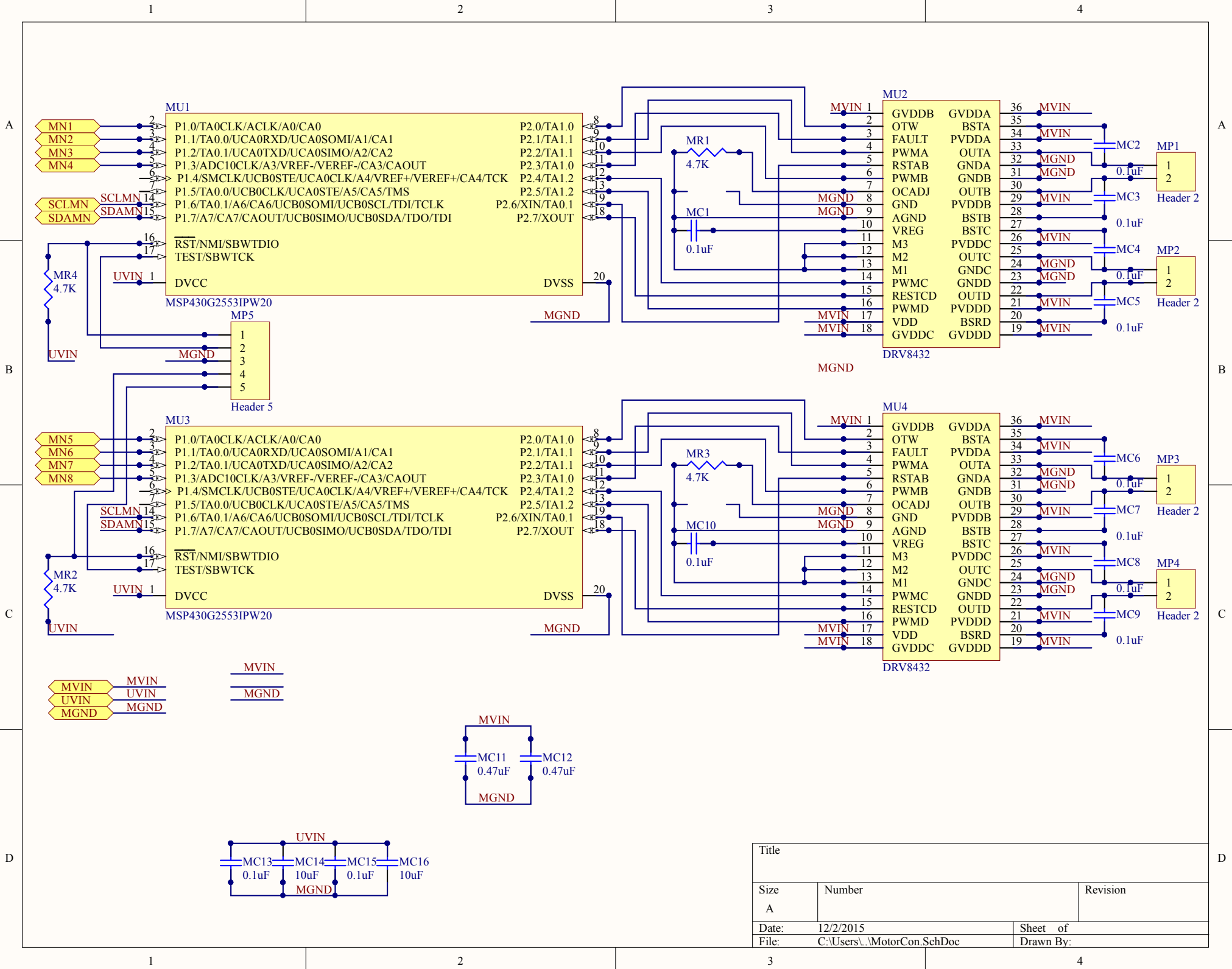

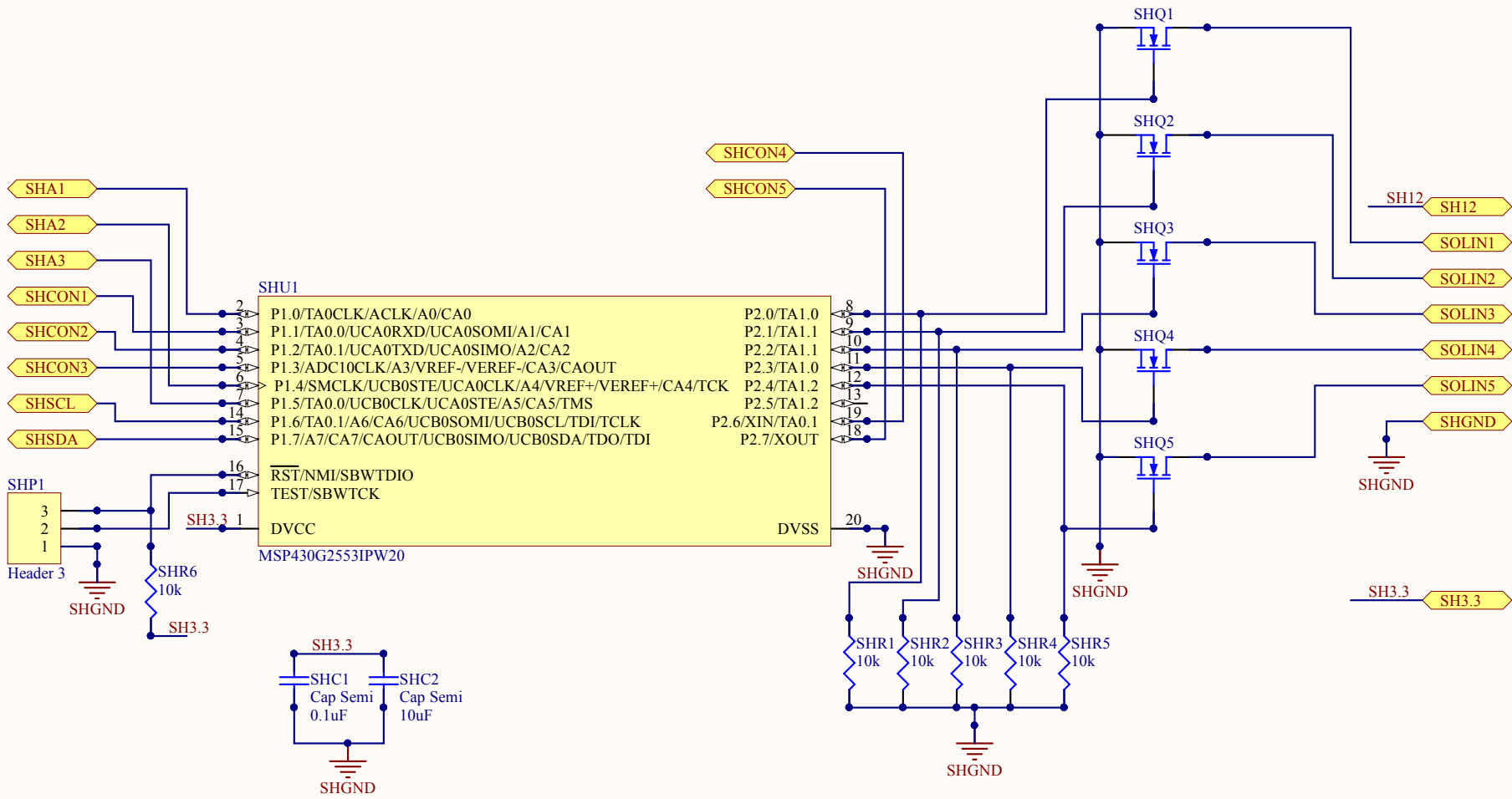

Title		
Size	Number	Revision
A		
Date:	12/2/2015	Sheet of
File:	C:\Users\...\SHIFTCOM.SchDoc	Drawn By:

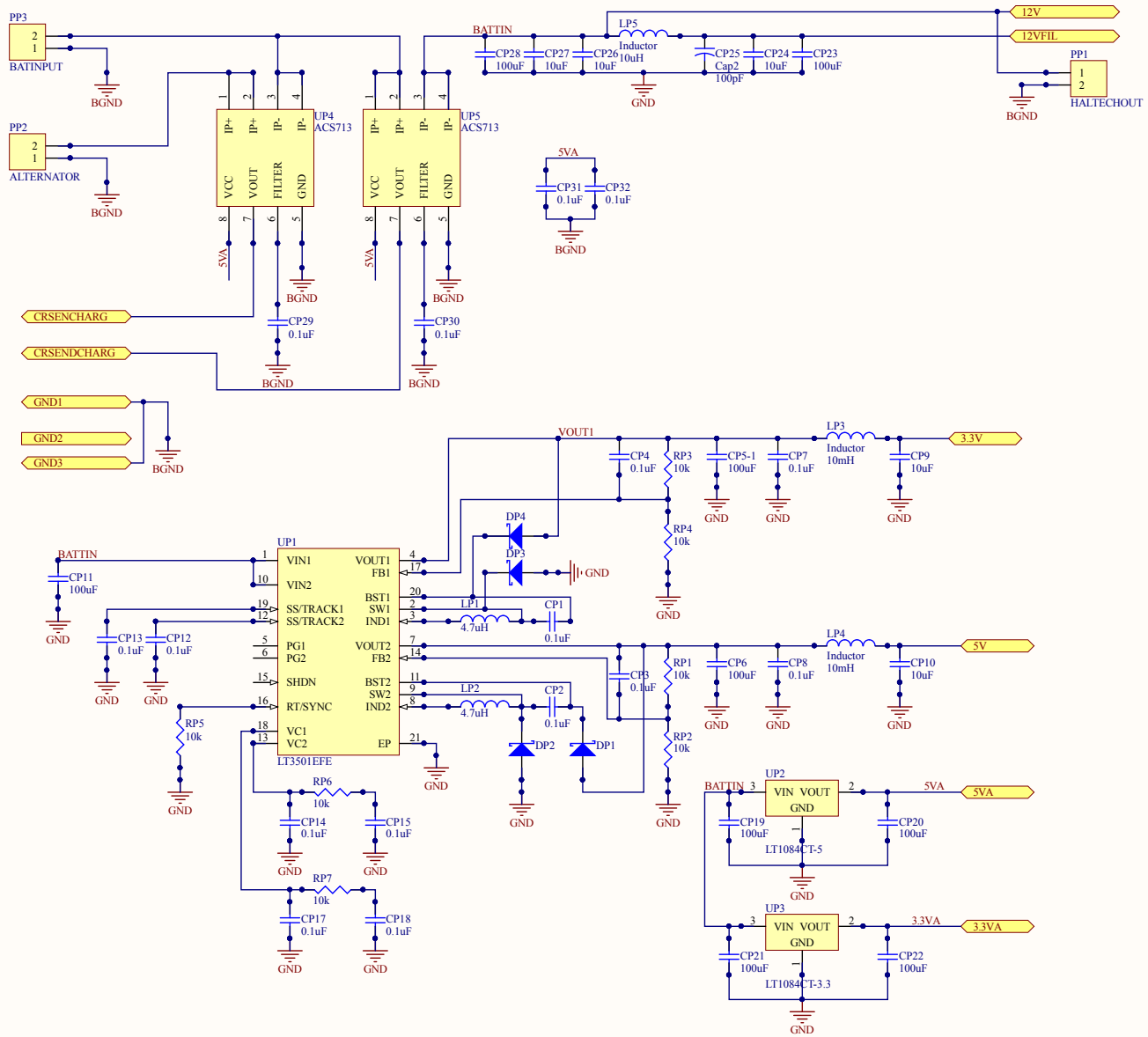

Title		
Size	Number	Revision
Date:	12/2/2015	Sheet of
File:	C:\Users\...MainPower.SchDoe	Drawn By:

## Wheel Board

- Wheel Board Schematic

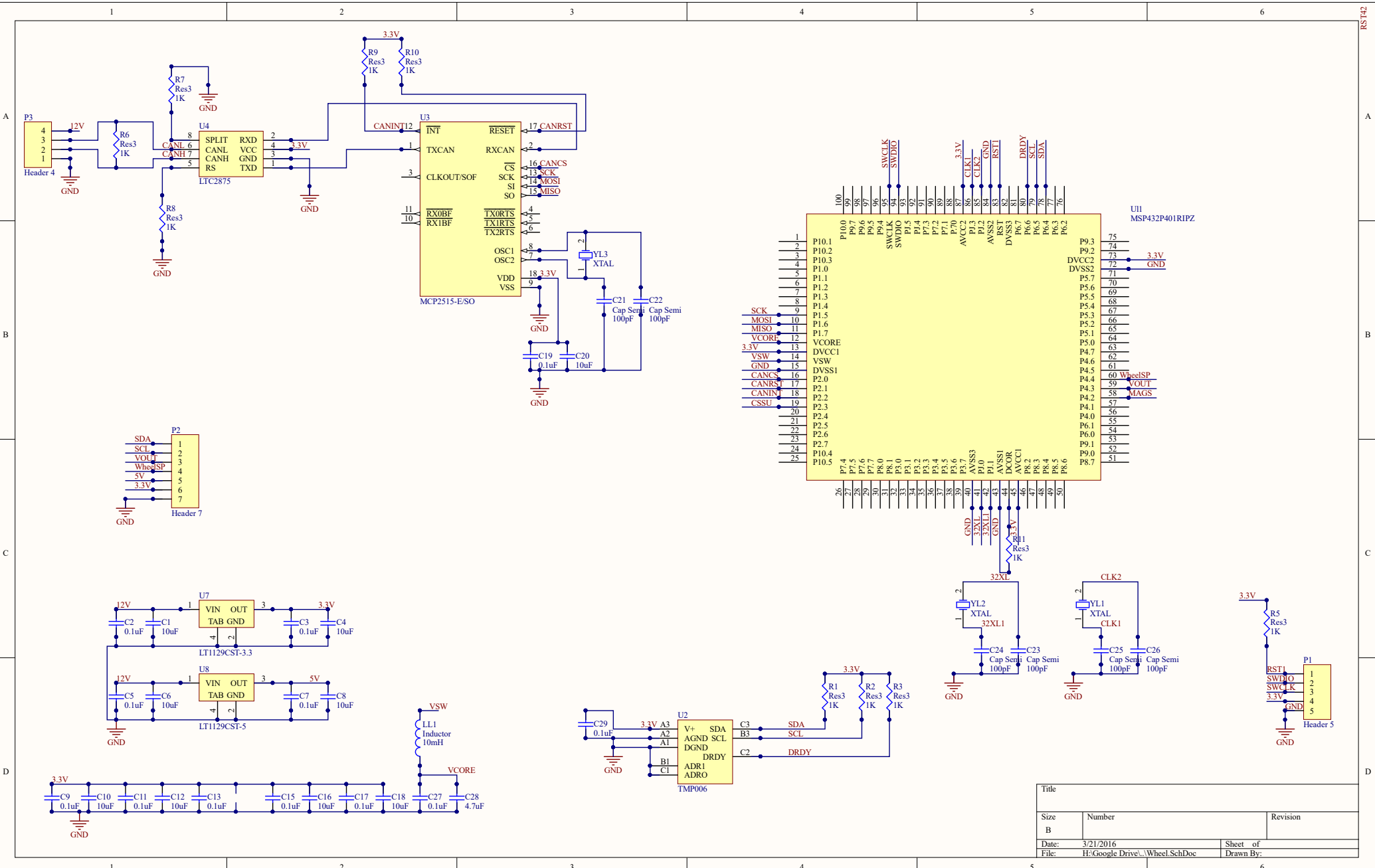

Title		
Size	Number	Revision
B		
Date:	3/21/2016	Sheet of
File:	H:\Google Drive\Wheel.SchDoc	Drawn By:

## Steering Wheel Board

- Main Logic
- Display Drivers
- LEDs
- Tactile Switch Interface
- Power Regulation

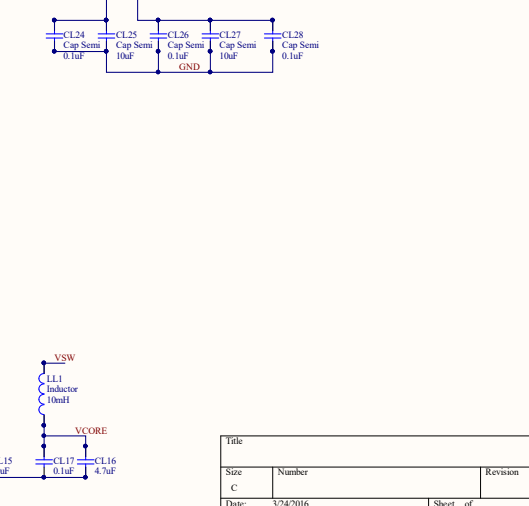
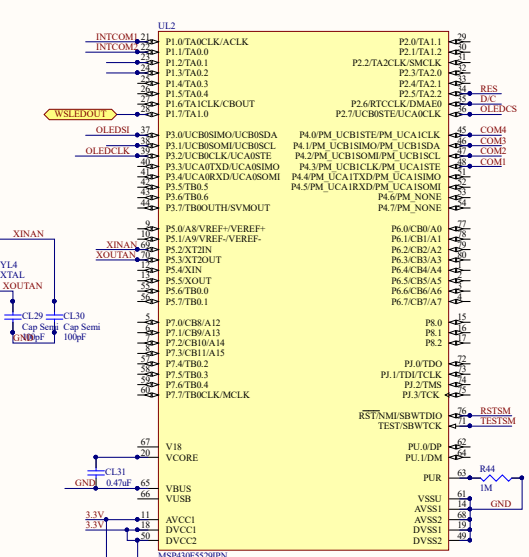
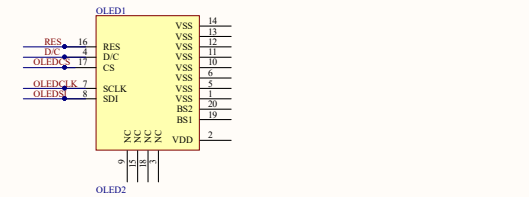
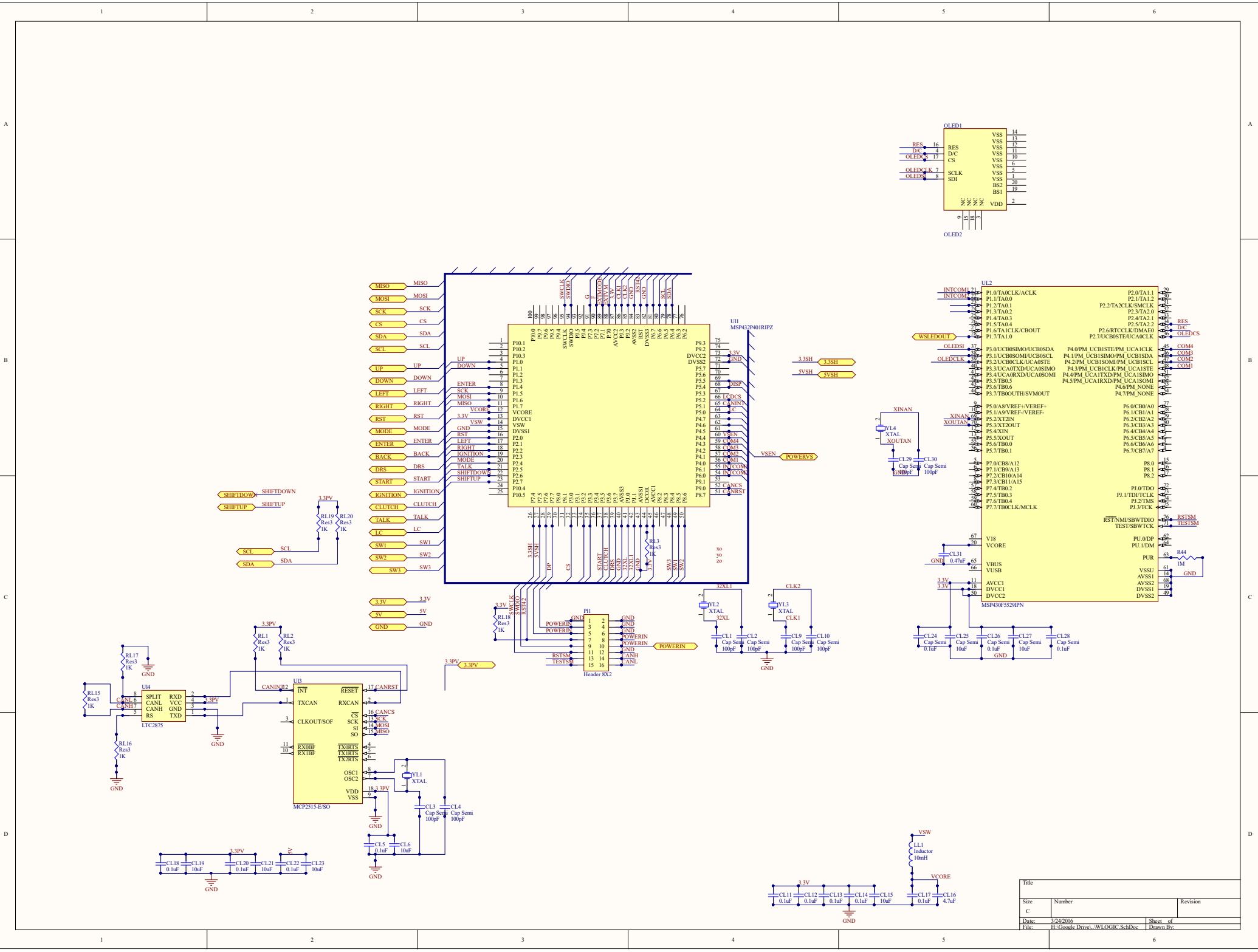

Title			
Size	Number	Revision	
C			
Date:	3/24/2016	Sheet of	
File:	H:\Google Drive\WLOGR_SchDoc	Drawn By:	



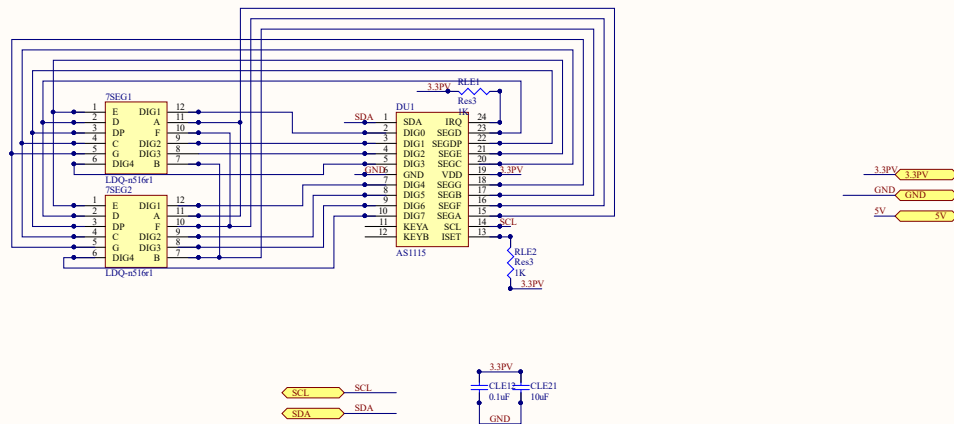

Title		
Size	Number	Revision
C		
Date:	3/24/2016	Sheet of
File:	H:\Goode\Draws\WSSLED.SchDoc	Drawn By:

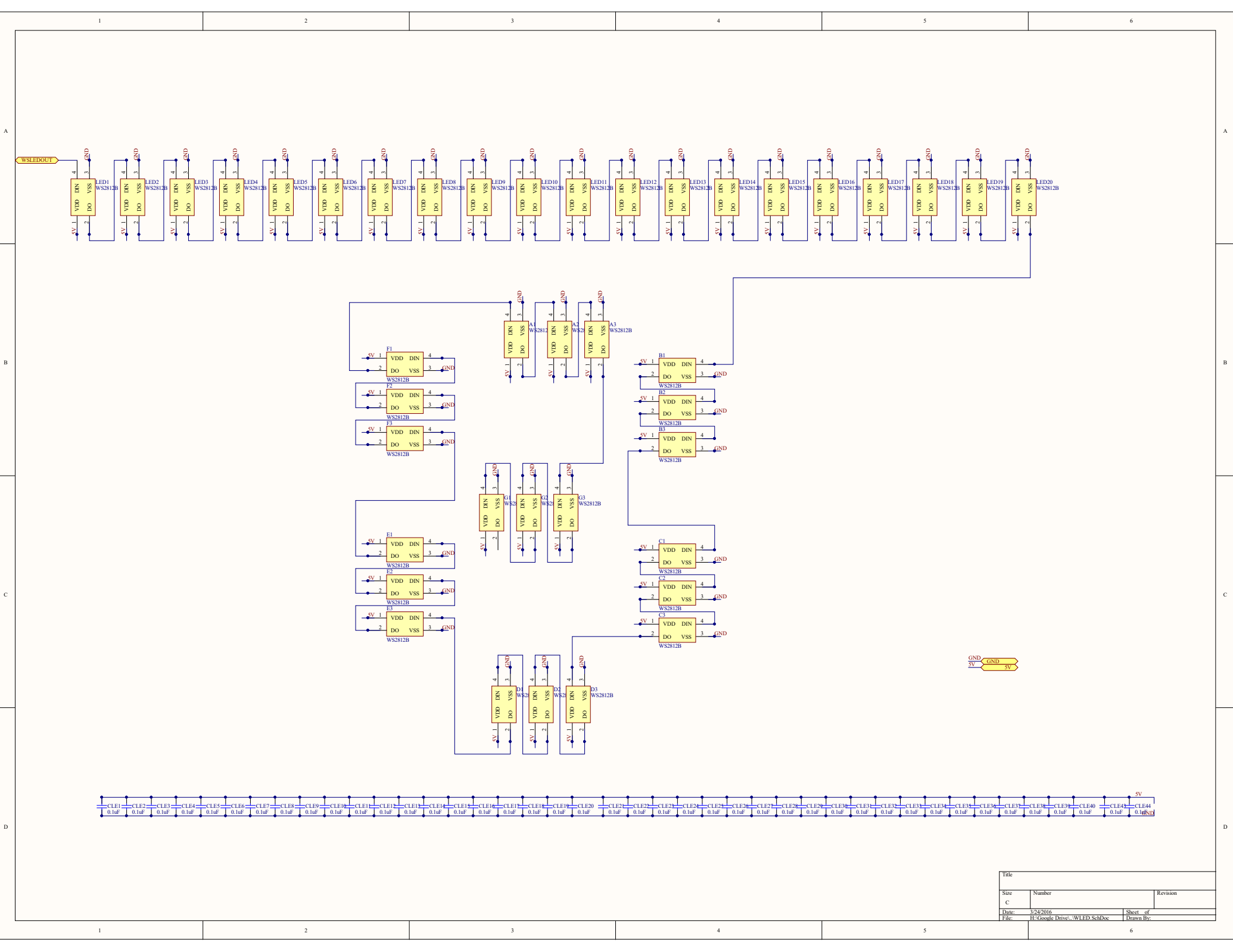

Title		
Size	Number	Revision
Date:	3/24/2016	Sheet of
File:	H:\Google Drive\WSLED SchDoc	Drawn By:

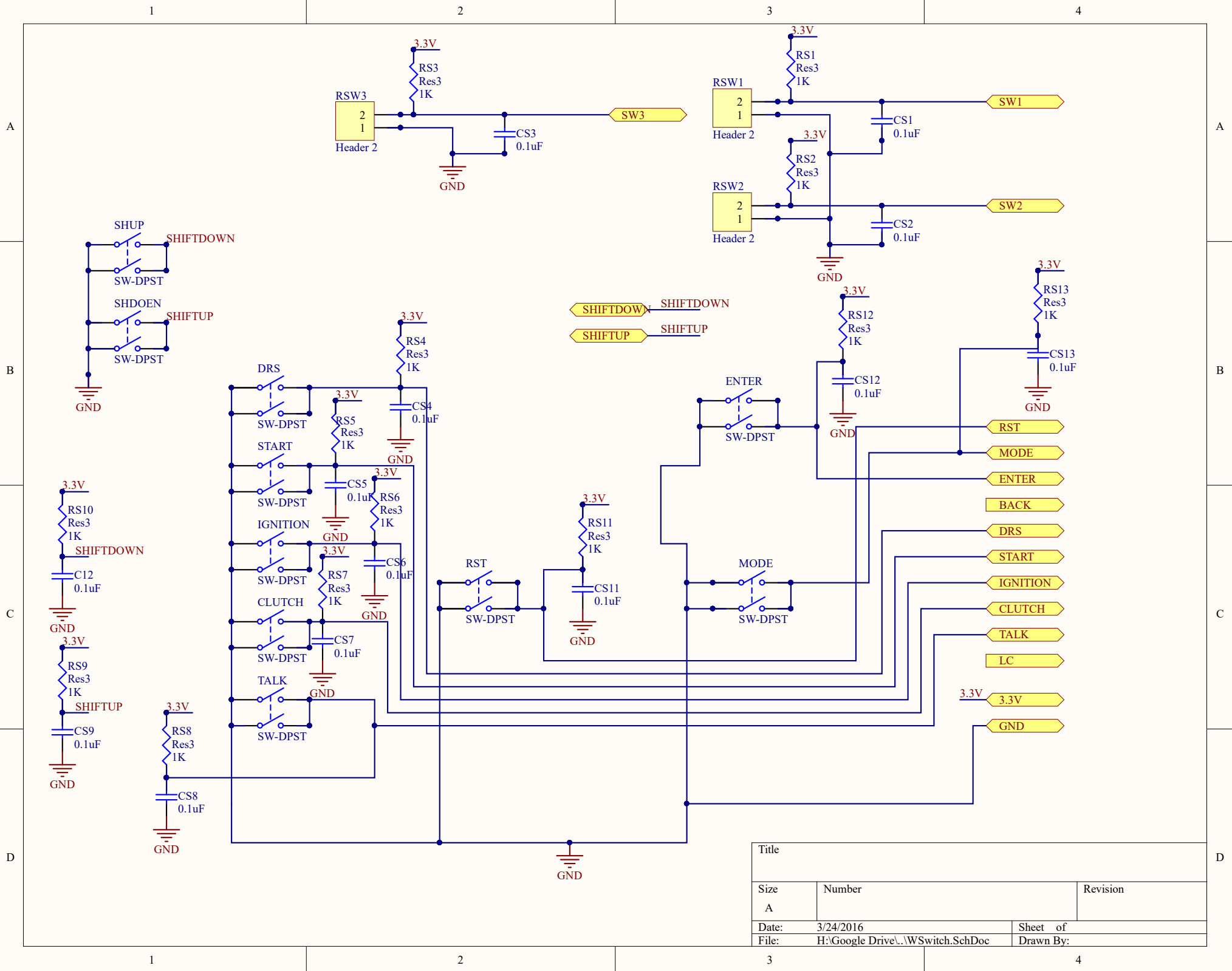

Title		
Size	Number	Revision
A		
Date:	3/24/2016	Sheet of
File:	H:\Google Drive\..WSwitch.SchDoc	Drawn By:

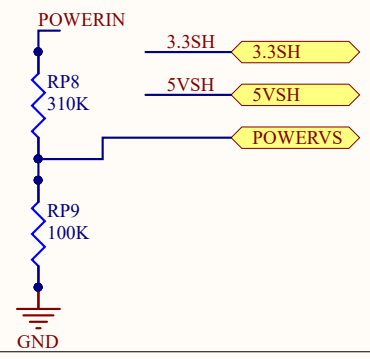
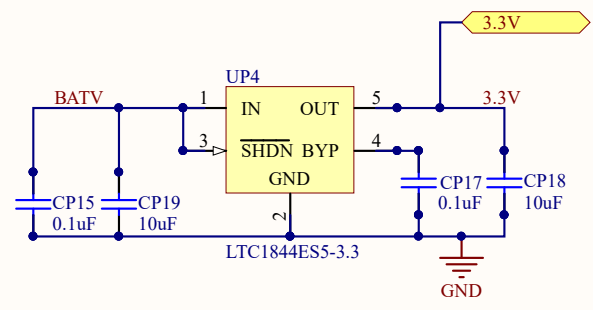
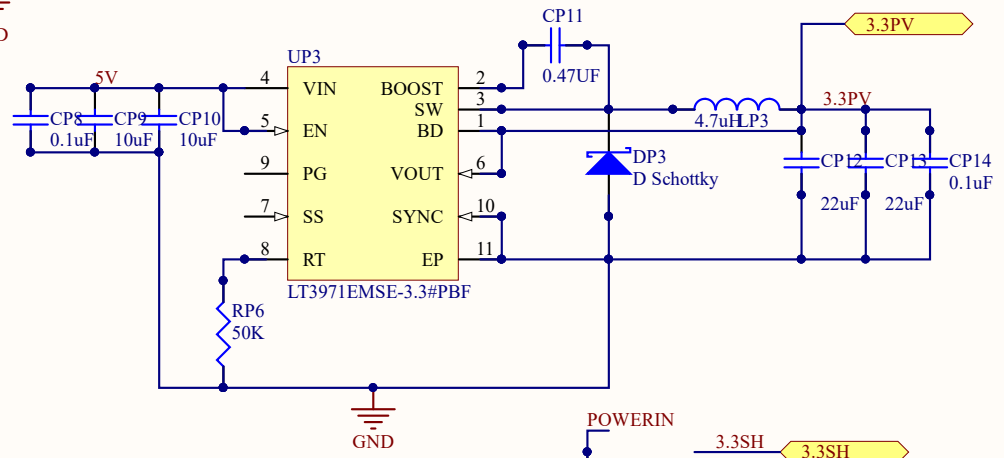
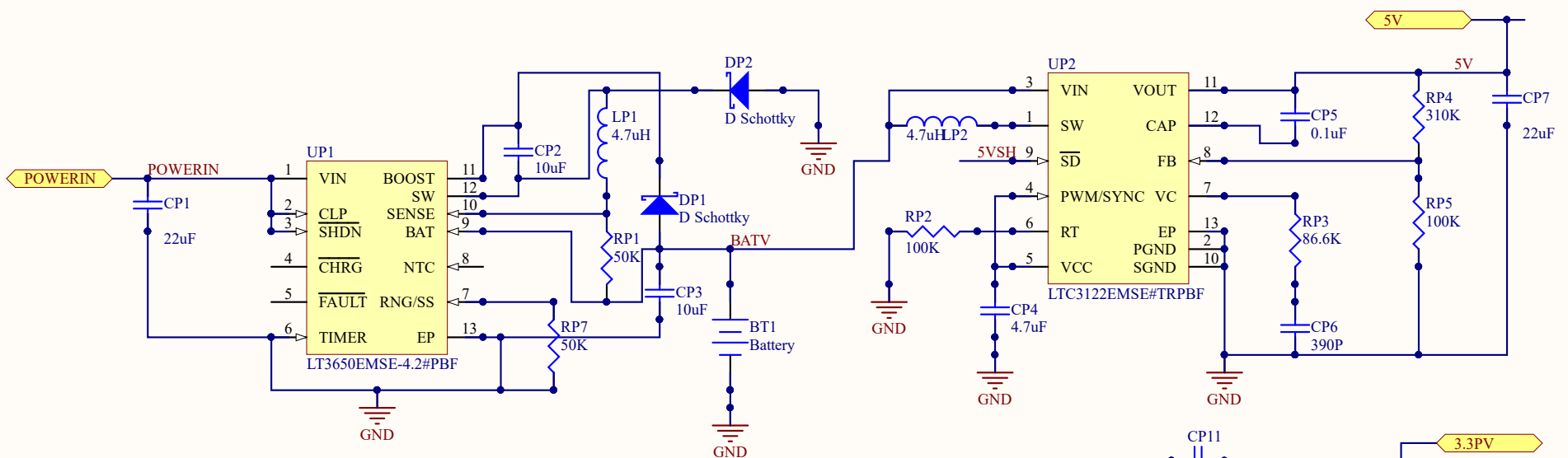

Title		
Size	Number	Revision
A		
Date:	3/24/2016	Sheet of
File:	H:\Google Drive\..WPPOWER.SchDoc	Drawn By:

## Steering Position Sensor Board

- [Steering Position Sensor Schematic](#)

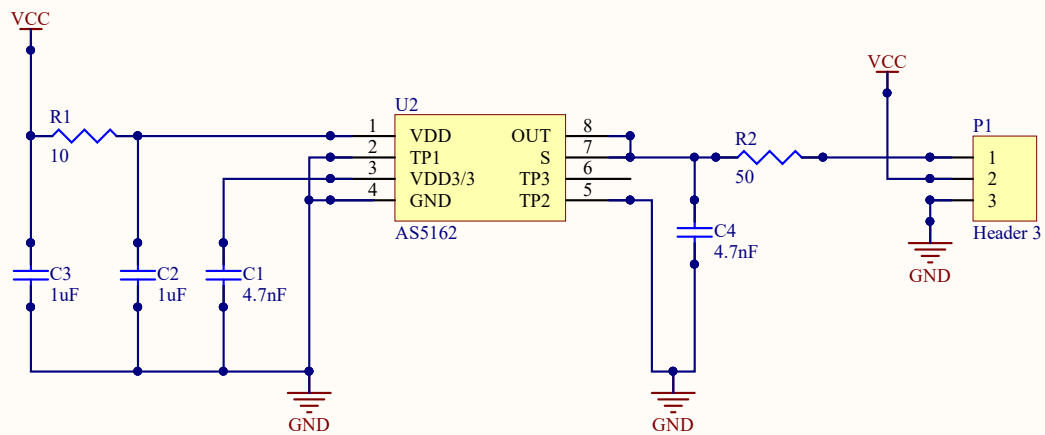

Title		
Size	Number	Revision
A		
Date:	3/21/2016	Sheet of
File:	H:\Google Drive\.\RPsch.SchDoc	Drawn By:

## Air Pressure Sensor Board

- Air Pressure Sensor Schematic

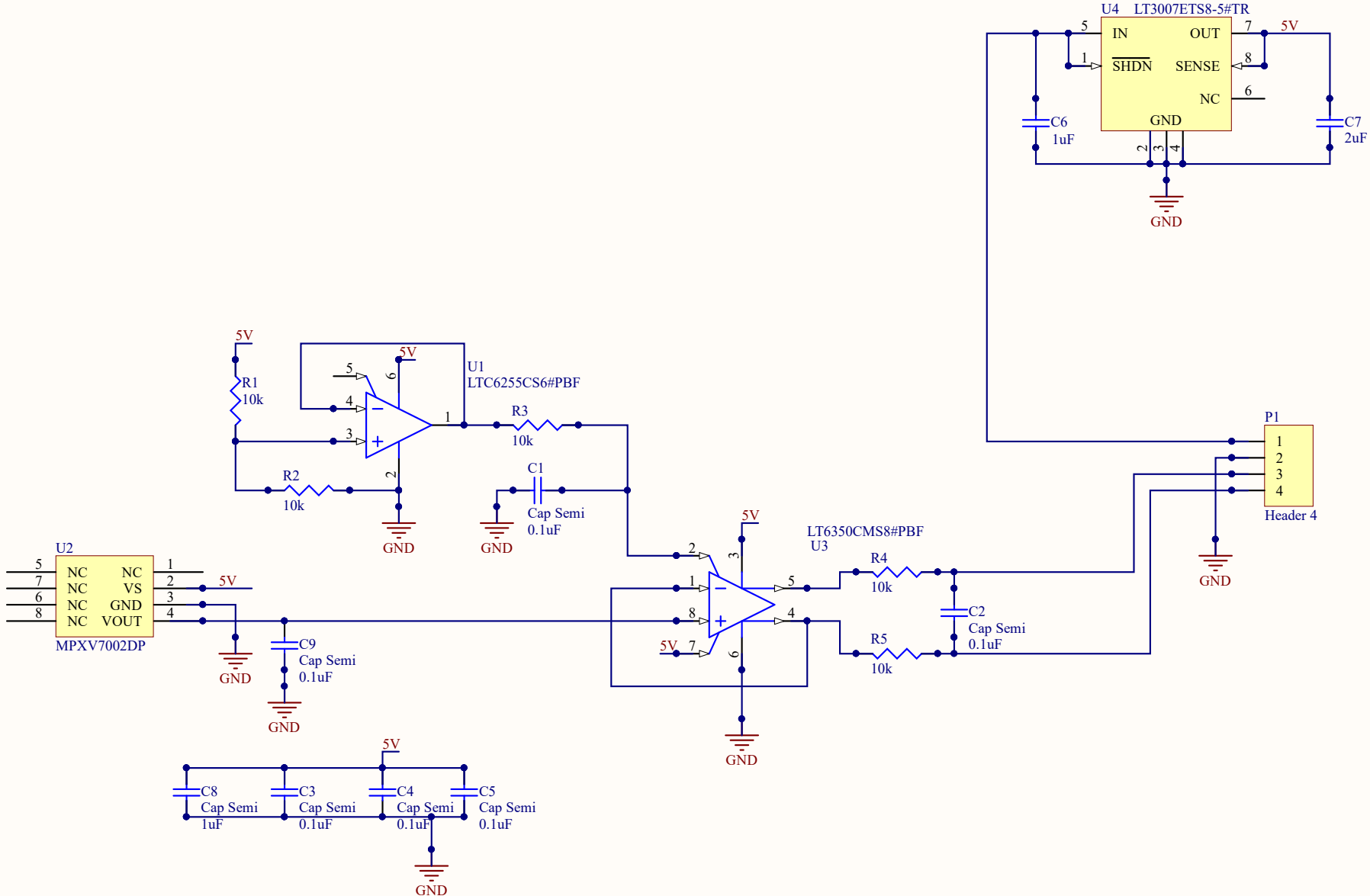

Title		
Size	Number	Revision
A		
Date:	3/21/2016	Sheet of
File:	H:\Google Drive\..AROSCH.SchDoc	Drawn By:



## Pit Computer Radio Board

- Pit Computer Radio Schematic

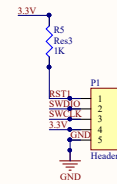
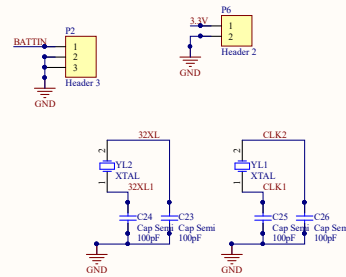
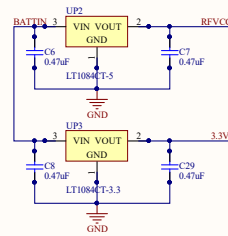
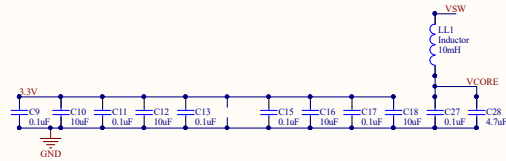
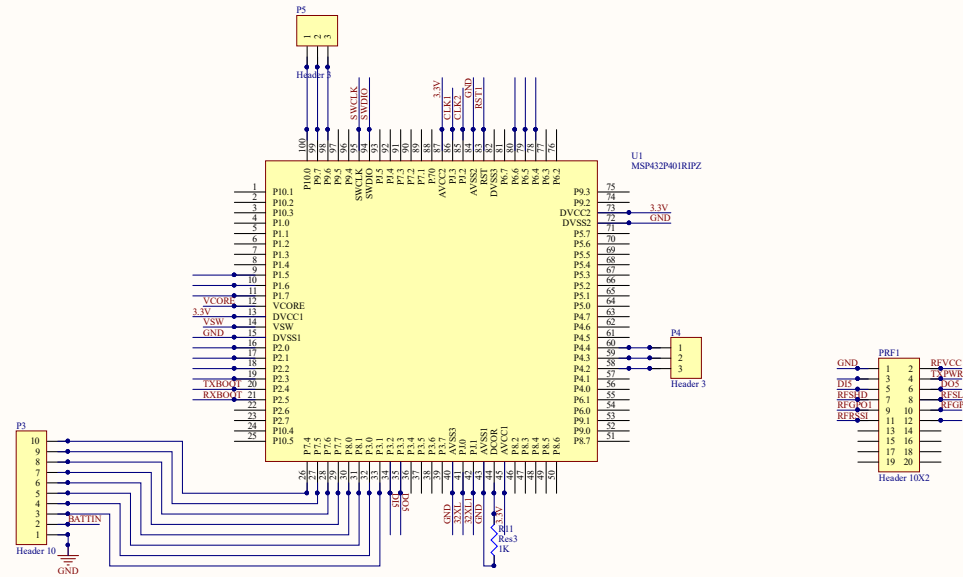
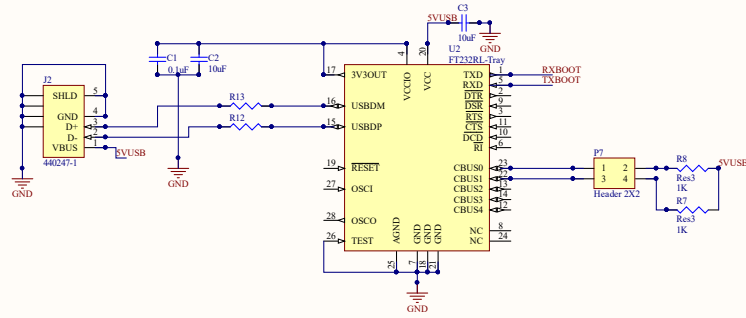

Title		
Size	Number	Revision
C		
Date:	3/21/2016	Sheet of
File:	H:\Google Drive\...Pir\elemesch\SchDec	Drawn By: