

September 2014

Cost-effective and Reliable Mechanism for Parking Brake Releasing on SMA

Chutian Zhao

Worcester Polytechnic Institute

Follow this and additional works at: <https://digitalcommons.wpi.edu/mqp-all>

Repository Citation

Zhao, C. (2014). *Cost-effective and Reliable Mechanism for Parking Brake Releasing on SMA*. Retrieved from <https://digitalcommons.wpi.edu/mqp-all/46>

This Unrestricted is brought to you for free and open access by the Major Qualifying Projects at Digital WPI. It has been accepted for inclusion in Major Qualifying Projects (All Years) by an authorized administrator of Digital WPI. For more information, please contact digitalwpi@wpi.edu.



WPI

MQP:

Cost-effective and Reliable Mechanism for Parking Brake Releasing on SMA

A Major Qualifying Project submitted to the faculty of Worcester Polytechnic Institute in partial fulfillment of the requirements for the Degree of Bachelor of Science

Submitted by:

Chutian Zhao

Date Submitted: 09/02/2014

Submitted to: Prof. Yiming Rong

Abstract

A group of two WPI students and four HUST students worked together to redesign the parking brake releasing system on Caterpillar 980H wheel loaders with Steel Mill Arrangement. Eliminating the original hydraulic components used in the system and replacing them with pure mechanical parts, the final designs provided financially attractive and reliable solutions for Caterpillar Inc, the sponsor of this project.

Acknowledgments

First, the author would like to thank Abbas Julaih, the author's project partner, for his solid contribution to the project and the composing of this report. The author would like to thank Phillip Dinh and Dany Dong from Caterpillar Inc. for their constant support and help during the project. Also, the author would like to thank the HUST advisors Professor Lingsong He, and Professor Yanhua Sun. In addition, the author would like to acknowledge Professor Amy Zeng for being a competent co-advisor and giving helpful comments on the final report and the weekly presentations. Lastly, many thanks and appreciations to Professor Kevin Rong for his substantial support and care, and for making this project a valuable experience.

Also, the author would like to thank his HUST partners: Jiawei Ge, Shuai Cui, Xiang Liu, and Haokai Yang for their significant efforts in the project and for being trustworthy friends.

Authorship

The report was finished by the two WPI students, with Chutian Zhao focusing on Introduction, background, methodology, and cost analysis, while Abbas Julaih concentrating on objectives, tasks, ethics, designs, calculation, and design recommendations. Throughout the project, WPI and HUST students worked together to obtain specifications, brainstorm, create designs, revise designs, and present the project.

Table of Contents

Abstract.....	2
Acknowledgments.....	3
Authorship	4
Introduction	9
Background	12
Caterpillar Inc.....	12
Description of 980H Wheel Loader with Steel Mill Arrangement (SMA)	12
Current Parking Brake System	14
Problems with the Current System.....	22
Problem Implications	23
Software Overview.....	24
Project Goal and Objectives.....	26
Tasks.....	27
Methodology.....	29
Design Functions.....	30
Mechanical Properties	31
Manufacturability	32
Cost	34
Ethics.....	35
Designs.....	36
Design Ideas	36
Selected Designs	42
Final Designs	46
Calculations.....	52

Tow Force Calculations	52
FEA of Design One.....	53
Design Recommendations	56
Cost Analysis	58
Results.....	62
References	64

Table of Figures

Figure 1 980H Wheel Loader with SMA	10
Figure 2 Parking Brake Override Control	13
Figure 3 Right Side of a Machine	14
Figure 4 Parking Brake Control Valve.....	15
Figure 5 Parking Brake Control Valve (Top View)	15
Figure 6 Parking Brake Control Knob	16
Figure 7 Parking Brake Control Valve (View A-A).....	17
Figure 8: 980H with SMA (rear grill shown).....	18
Figure 9 Accumulators	19
Figure 10 Components of a Brake Accumulator	19
Figure 11 Transmission Neutralizer Override Switch.....	20
Figure 12 (1) Alert indicator for the transmission neutralizer override switch	21
Figure 13 Components for PBR on a SMA.....	23
Figure 14 Project Schedule	28
Figure 15 Project Methodology	29
Figure 16 Design Functions	30
Figure 17 Specifications List.....	31
Figure 18 House of Quality.....	34
Figure 19 Design Idea 1.....	37
Figure 20 Design Idea 2.....	38
Figure 21 Design Idea 3.....	39
Figure 22 Design Ideas Comparison.....	41

Figure 23 Table of Design Rankings	42
Figure 24 Selected Design 1 - Overview.....	42
Figure 25 Selected Design 1 - Spring.....	43
Figure 26 Selected Design 1 - Lever	44
Figure 27 Selected Design 2 - Overview.....	45
Figure 28 Selected Design 2 - Inner Structure	45
Figure 29 Final Design 1 - Overview.....	47
Figure 30 Final Design 1 - Hook.....	47
Figure 31 Final Design - Modification	48
Figure 32 Final Design 2 – Modification 2.....	49
Figure 33 Final Design 2 – Modification 2.....	49
Figure 34 Final Design 2 - Overview.....	50
Figure 35 Table of Final Designs Comparison	51
Figure 36 Final Design 1 FEA - Stress	53
Figure 37 Final Design 1 FEA - Displacement	54
Figure 38 Final Design 1 FEA - Safety Factor Test	55
Figure 39 Reinforcement	56
Figure 40 Direct Materials Cost	59
Figure 41 Direct Labor Cost.....	60
Figure 42 Cost Reduction	61

Introduction

Construction equipment has played a significant role in the development of world economy. One of the important heavy equipment, wheel loaders are used in construction to move or load materials such as dirt, rock, asphalt, logs, sand, etc. Wheel loaders generally work under extreme environments, which lead to frequent safety hazards.

Parking brake systems, used for keeping machines stationary and preventing them from rolling, are important parts of heavy equipment brake systems. Operators who use those machine rely heavily on the parking brake since an accidental roll of such heavy machine can lead to catastrophic results. Reliable parking brake systems are needed to withstand harsh working conditions. Heavy construction machines like wheel loaders are not allowed to drive on highways. This increases the use of the parking brake dramatically since every time they need to be loaded and unloaded, so that the parking brake has to be released and then reactivated. Also, parking brake systems must be cost-effective in order to be equipped on each of the machines. Therefore, a reliable, cost-effective parking brake system is critical to the success of a wheel loader design.

This project aimed to help Caterpillar Incorporation by redesigning the parking brake releasing (PBR) mechanism on the 980H wheel loader with Steel Mill Arrangement (SMA).



Figure 1 980H Wheel Loader with SMA

In the event of an engine failure, the parking brake of the 980H will automatically engage to prevent the machine from further danger. The 980H uses a hydraulically-released system as an emergency brake to provide automatic fail-safe braking in case of a hydraulic fluid power loss. In order to tow the machine for service, the engaged brake must be released in an emergency. The hydraulic system requires an accumulator, an alternate hydraulic pump and valves with fluid from the pump being controlled by the parking brake. Those hydraulic components on each vehicles are complicated and add cost to the vehicle. Thus, the current hydraulic PBR system is less reliable and financially attractive than expected.

Therefore, a new design that can solve these problems is necessary to Caterpillar. This design can potentially save not only millions of dollars but also lives. Many studies have been done on alternatives and solutions to a better parking brake systems. While some of those studies consider an addition of electrical circuits that activates the parking brake releasing system, which allows the machine in emergency to be towed for repairing, the system considered in this project would be purely mechanical in order to make the system reliable and financially attractive.

In addition, because the brake mechanism is a very essential part of any vehicle, this project can impact many people as well as different businesses. For example, people who live on hills or high lands with steep roads need to apply the emergency brake to keep their vehicles from rolling down. Therefore, a reliable and cost-effective design of the brake mechanism will benefit not only Caterpillar but also many other companies in the automobile industry.

Background

This section provides a background on the sponsors and a description of the machinery that was involved in this project. It also explains the current parking brake mechanism and its implications.

Caterpillar Inc.

Caterpillar Inc. is a leading manufacturer of heavy equipment and machinery in the industrial world. With \$5.68 billion net income in 2011, Caterpillar was ranked 44 on Fortune 500 overall list. Ranked number one in its industry, Caterpillar offers solutions for construction and manufacturing by providing customers with durable and reliable equipment (Caterpillar | Caterpillar, 2014).

Description of 980H Wheel Loader with Steel Mill Arrangement (SMA)

Caterpillar builds a complete line of wheel loaders: compact wheel loaders, small wheel loaders, medium wheel loaders, large wheel loaders, and block handler arrangements. With medium sizes, medium wheel loaders offer world-class performance with the ability to work in the most demanding environments (Wheel Loaders, 2014). One of the newest members of Caterpillar wheel loader series is the 980H wheel loader, which was introduced in both United States and Japan in 2005.

The Steel Mill Arrangement (SMA) equipped on the 980H wheel loader is designed for machines working in the environment of a steel mill application, protecting the machine system

from the extreme heat and the harsh environment. The Steel roof and cab skirts protect the machine from heat and debris. A transmission override control in the cab allows the operator a secondary transmission control when transmission Electronic Control Module is damaged. The SMA on a 980H wheel loader is equipped with a front frame guard and steering cylinder guards to protect sensitive machine components from the effects of hot materials. Hydraulic and electrical systems are specially designed to be insulated from extreme heat. To increase safety, a parking brake override control located at the rear grill allows the parking brake to be disabled and enable if the engine is not running (Specalog for 980H Wheel Loader, 2014).

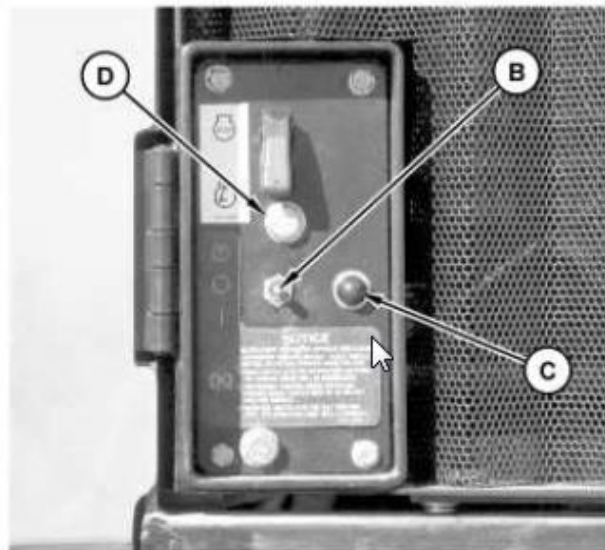

Illustration 2

g01338889

Override switches and indicator for parking brake

(B) Override switch for the parking brake

(C) Override indicator for the parking brake

(D) Auxiliary engine shutdown switch

Figure 2 Parking Brake Override Control

Current Parking Brake System

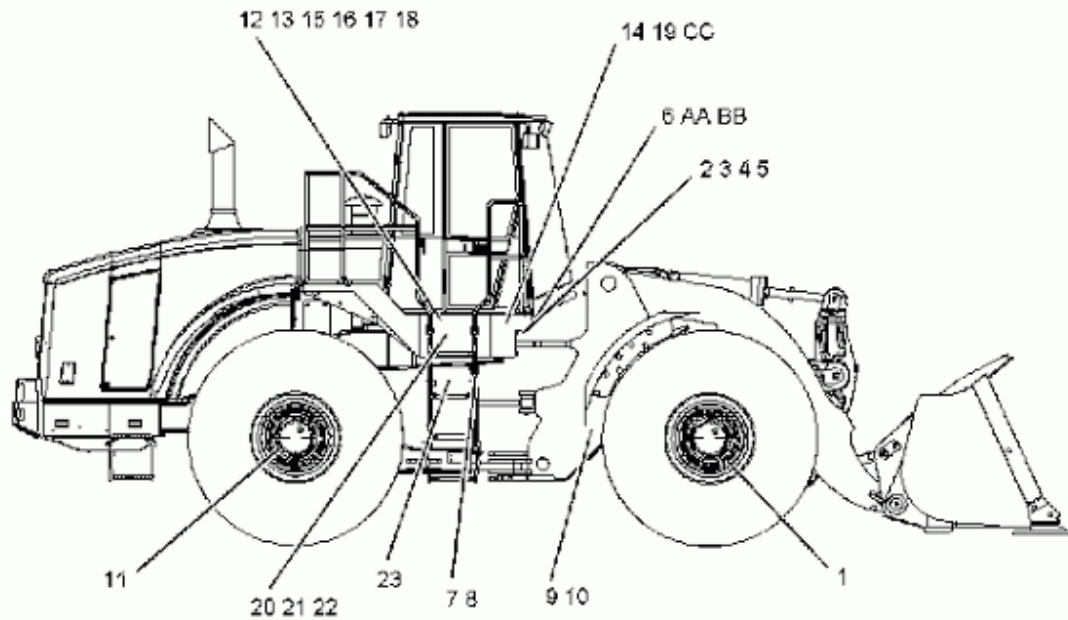

Figure 3 Right Side of a Machine

- (2) Wire to the transmission neutralizer
- (7) Accumulator for the front service brakes
- (8) Accumulator for the rear service brakes
- (9) Parking brake
- (10) Parking brake actuator
- (12) Accumulator charging valve
- (13) Parking brake pressure switch for Power Train Electronic Control Module (ECM)
- (19) Parking brake control valve
- (23) Hydraulic oil tank

The braking system on a 980H wheel loader consists of three parts:

1. Service Brake
2. Parking Brake
3. Brake Charging System.

Based on the provided description, this project will be focusing on the parking brake system.

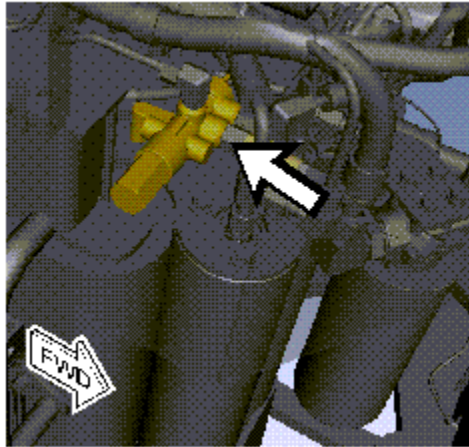

Figure 4 Parking Brake Control Valve

The parking brake control valve is located on the right side of the machine, and is mounted on a plate fastened to the top of the hydraulic service center. The parking brake control valve controls the hydraulic oil flow for the parking brake actuator.

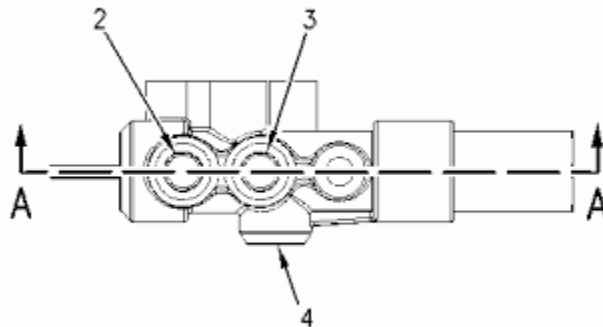

Figure 5 Parking Brake Control Valve (Top View)

- (2) Port for the hydraulic oil tank.
- (3) Port for the parking brake actuator.
- (4) Pressure port that is connected to the accumulator for the rear service brakes.

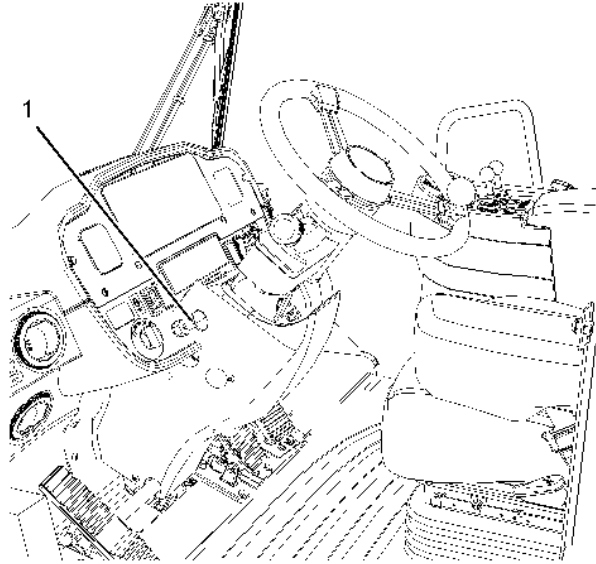

Figure 6 Parking Brake Control Knob

(1) Parking brake control knob

On a standard 980H wheel loader (without SMA), operators control the parking brake system using the parking brake control knob (1) located in the cab.

Pushing in on the parking brake control knob will disengage the parking brake, which causes spool and retainer to move right and compress the spring (10). This allows pressure oil to flow into the pressure port from the brake accumulator for the rear service brakes. The oil then flows out of the port for the parking brake actuator (3). The oil then flows into a cavity in the actuator assembly for the parking brake. When the oil pressure in the cavity for the parking brake actuator is high enough to compress the actuator spring, the parking brake disengages. The pressure of the oil keeps the parking brake in the DISENGAGED position.

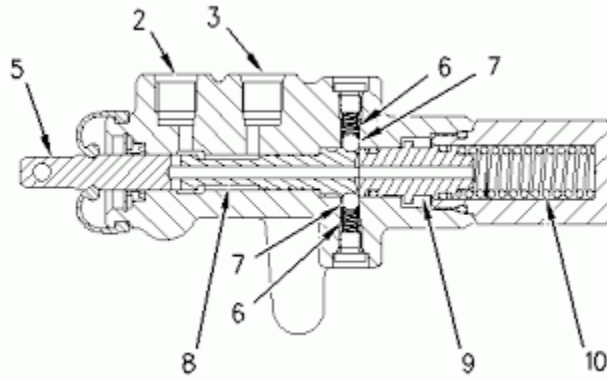

Figure 7 Parking Brake Control Valve (View A-A)

- (2) Port for the hydraulic oil tank.
- (3) Port for the parking brake actuator.
- (4) Pressure port that is connected to the accumulator for the rear service brakes.
- (5) Stem for the parking brake control valve.
- (6) Detent springs.
- (7) Detent balls.
- (8) Spool.
- (9) Retainer. (10) Spring.

Pulling out on the parking brake control knob (1) will engage the parking brake. This will cause spool (8) and retainer (9) to move left. The flow of pressure oil to the parking brake actuator will stop and the oil in the cavity of parking brake actuator to flow back to the hydraulic oil tank.

When there is a decrease of hydraulic oil pressure in the service brake circuit, the spring-activated parking brake will automatically be engaged by the parking brake control valve. In this situation, the force of spring (10) moves the spool (8) to the left, which blocks the flow of oil that compresses the spring (10). In turn, this will cause the spring retainer (9), the spool (8) and the stem (5) move to the left.

The parking brake releasing on a 980H machine with SMA is through the rear grill.

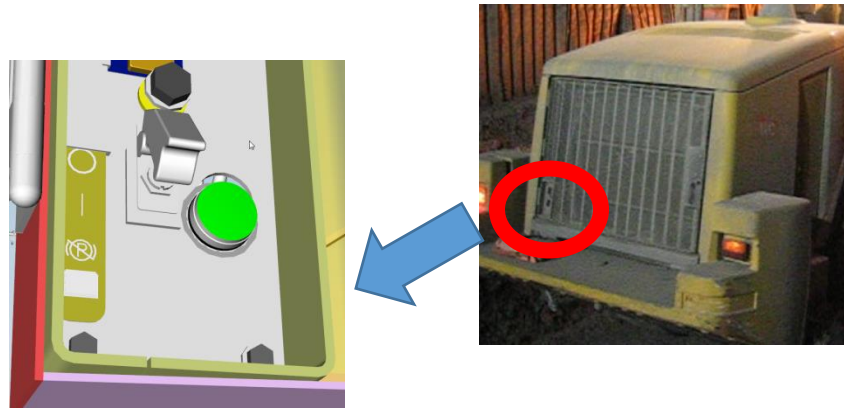

Figure 8: 980H with SMA (rear grill shown)

To release the parking brake again for towing, the toggle switch, which is located in the rear grill of the machine, needs to be moved downward. The toggle switch is connected to accumulators that store hydraulic pressure. The accumulator will release the parking brake when the switch is activated.

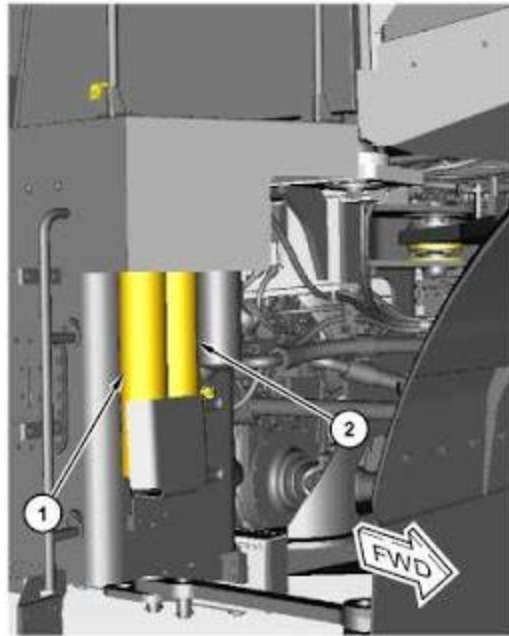

Figure 9 Accumulators

(1) Accumulator for rear service brakes. (2) Accumulator for front service brakes.

There are two brake accumulators located on the right side of the machine. They are positioned next to the hydraulic tank.

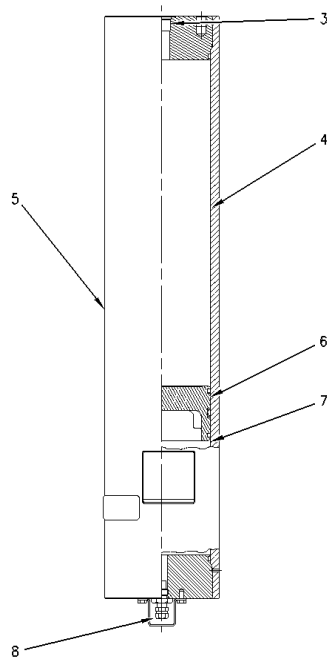

Figure 10 Components of a Brake Accumulator

- (3) Outlet to the service brake control valve.
- (4) Pressure oil chamber.
- (5) Accumulator.
- (6) Piston.
- (7) Chamber for nitrogen gas. (8) Nitrogen charging valve.

Hydraulic oil will flow from accumulator charging valve, which controls the amount of oil flows to the brake accumulators, into the accumulator through port (3) and enters the pressure oil chamber (4). The oil pushes a piston located inside the accumulator and compresses the nitrogen gas. Pushing down either brake pedal will make the oil from chamber (4) flow out of port (3). The oil will apply service brakes and then flows out of the port for parking brake actuator (3).

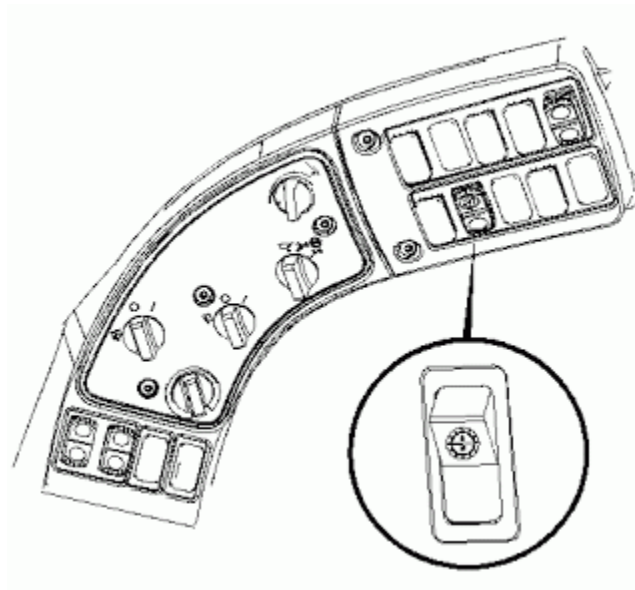

Figure 11 Transmission Neutralizer Override Switch

The transmission neutralizer override switch is located on the switch panel on the upper right side of the cab. The transmission neutralizer override switch is a momentary rocker switch. The transmission neutralizer override switch allows the operator to disable the functioning of the

transmission neutralizer.

Note: The default status of the transmission neutralizer is active. Whenever the machine is turned on, the transmission neutralizer will be enabled.

Press the top of the transmission neutralizer override switch in order to disable the transmission neutralizer. When the transmission neutralizer is disabled, use of the left brake pedal will not disengage the transmission. The left brake pedal will function as a conventional brake pedal.

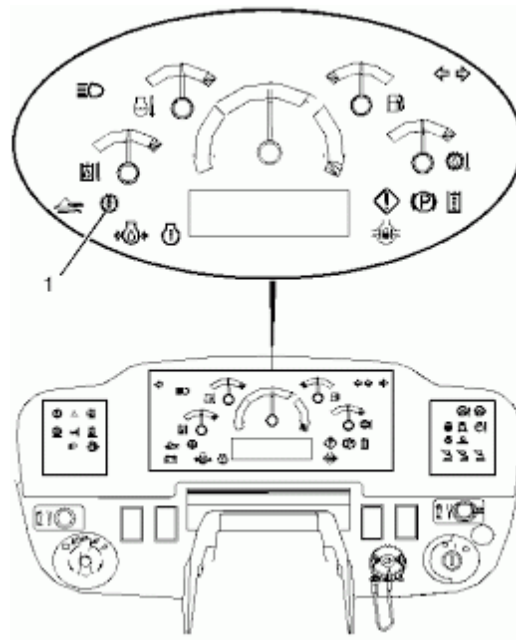

Figure 12 (1) Alert indicator for the transmission neutralizer override switch

The alert indicator for the transmission neutralizer override switch (1) is located on the dash. The alert indicator is on when the neutralizer is disabled. When the neutralizer is active, the alert indicator will be off.

If the transmission neutralizer has been disabled, press the top of the switch again in order to activate the transmission neutralizer. When the transmission neutralizer is active, the operator may depress the left brake pedal in order to engage the transmission neutralizer. The

transmission neutralizer will disengage the transmission as the service brakes are applied.

Allowing the operator to press the accelerator pedal in order to increase engine speed for better hydraulic response. There is also a gain in fuel efficiency and a reduction in transmission oil temperatures. A parking brake pressure switch is used to signal the power train electronic control module. The transmission automatically shifts into the NEUTRAL position when the parking brake is applied (CONSTRUCTION EQUIPMENT, 2014).

Problems with the Current System

The most significant problem with the current system is that it uses a hydraulic system, which is expensive and makes the PBR unreliable and complicated. The main components of the current hydraulic system consist of accumulators, hydraulic pumps and valves. The three main components combined cost about \$5,000 to \$10,000. Therefore, the system is costly to be added on every machine and makes the 980H design team consider to switch to a more cost-effective solution. The accumulator on the current system requires an auxiliary accumulator to be equipped as a backup pump to provide the system with hydraulic fluid pressure in case of a system failure. A hydraulic system is by its nature less reliable than a pure mechanical one.

Another disadvantage of current system is that the brake prevents a disabled machine from easily being towed. The parking brake will engage automatically when there is a loss of hydraulic pressure in the system. In the event of a system failure, an auxiliary accumulator starts to work as a backup pump, and provides the system with hydraulic fluid pressure that is applied to the parking brake. In order to release the parking brake through manipulating toggle switch on the rear grill, all the parts in Figure 11 are added to the standard brake system. The system is costly to be added on every machine, and increases the time needed to remove a disabled

machine to permit its repair. Additionally, the current system provides no means for applying brake to the disabled machine while being towed, which is an important safety consideration.

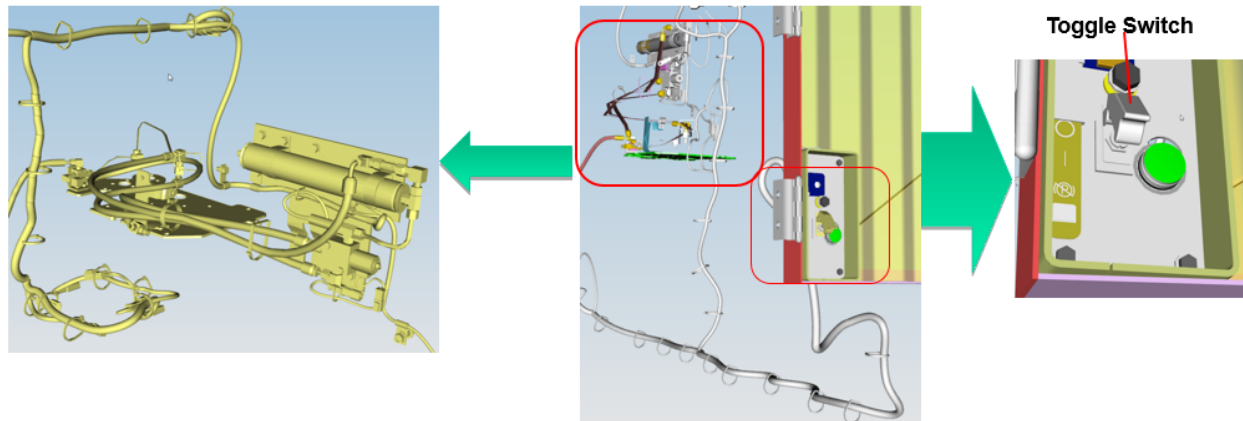

Figure 13 Components for PBR on a SMA

Problem Implications

Construction requires efficiency and safety, which are essential to the success of projects. Playing an important role in construction and material loading, a wheel loader must be reliable and inexpensive. The above factors require that a wheel loader equipped with efficient fail-safe systems to prevent significant losses from happening. A parking brake system, used to keep a vehicle stationary and prevent it from rolling, is necessarily and must be reliable and safe.

The problem addressed in the previous section can be found particularly in wheel loaders used in certain working environments, where access to a disabled machine is limited and the distance to a maintenance area is great. Failing to tow a disabled machine may lead to extra costs and longer wait times, which can be huge losses.

Additionally, wheel loaders equipped with SMA generally work in environments with extreme heat and gases. In such working environments, pressure losses/leakages in hydraulic systems are frequent, which increases the uncertainty of the system. Therefore, the problems with the current parking brake releasing mechanism are necessary to be addressed.

Software Overview

The software packages that were used to guide the success of this project are listed below with a brief introduction to each package.

Pro/Engineer

Pro/Engineer (Pro/E) is a parametric, integrated 3D CAD/CAM/CAE solution created by Parametric Technology Corporation (PTC). It is used by engineers for design and manufacturing purposes. It provides solid modeling, assembly modeling, drafting, and finite element analysis. Pro/Engineer is frequently used to create complete 3D digital models for products. It provides a platform for design, analysis and manufacturing. All formats included in the software are associative and interchangeable between CAD, CAE and CAM modules without conversion (PTC Creo Elements/Direct Modeling Express 6.0, 2014).

Ansys

Ansys is an engineering simulation software, used to simulate interactions of all disciplines of physics, structural, vibration, fluid dynamics, heat transfer and electromagnetic. It is often used to simulate tests or working conditions. It enables engineers to test their designs in virtual environment before manufacturing prototypes of products. Ansys can import CAD data

and generate finite element model. After defining loadings and carrying out analyses, results can be viewed numerically and graphically (What Is ANSYS, 2014).

SolidWorks

SolidWorks is another tool for creating 3D designs. It includes parts modeling, assembly modeling, and dynamic rendering. It is also known for its simplicity and user-friendly interface. It can be used for prototyping future products, and to communicate ideas between design teams. The software package supports many formats and its products can be shared between many different platforms (SolidWorks Premium | SolidWorks, 2014).

Autodesk Inventor

Autodesk Inventor is a mechanical modelling software for creating 3D digital prototypes. It aids mechanical design process by allowing users produce 3D models to visualize and simulate the designs before they are built. In this project, Autodesk Inventor was used to perform FEA calculations (3D CAD Software for Mechanical Design, 2014)

Project Goal and Objectives

The goal of this project was to develop a mechanical design for the parking brake releasing on 980H wheel loader with steel mill arrangement. The mechanical design had to be optimized in terms of cost, simplicity, and reliability. In order to achieve this goal a set of objectives were created to measure the success of the project.

The objectives are listed below:

1. Designing a mechanical system for:
 - a. Shutting down the engine
 - b. Controlling the parking brake releasing
2. Validating mechanical properties of the new design
3. Conducting manufacturability analysis
4. Performing cost analysis

Tasks

Objectives were established based on the goal of this project. Similarly, the tasks needed to finalize the set of objectives have to be created. The project tasks are guidelines to achieve each objective in an efficient and organized manner. Those tasks were summarized in the following points:

- Acquiring specifications from sponsors
 - Good communications during entire length of project
- Familiarizing with Pro/E and Ansys and SolidWorks
 - Required skills and understanding of software components
- Forming designs based on specifications
 - Step-by-step design guide
 - Requirements setup
 - Alternatives
- Discussing and comparing of designs
 - Feedback from advisors
 - Pros and Cons comparison
- Confirming revised designs
 - Feedback from sponsors
- Revising selected models
 - Optimal design and alternatives
- Performing stress analysis
 - Loads limits

- Distribution of loads
- Performing cost analysis
 - Cost model
 - Statistical data
- Finalizing an optimal design
 - Justifications for the final design

Since the project had to be completed in seven weeks, the following table was created to make a timeline for the tasks:

Task	Pre-Arrival	Week 1	Week 2	Week 3	Week 4	Week 5	Week 6	Week 7
Clarifying Specification	X	X	X	X	X			
Familiarizing with Software	X	X						
Creating 3D Designs			X	X	X	X	X	
Performing Movement Calculations						X	X	
Rendering Simulation							X	X
Selecting an Optimal Design and Alternatives							X	X
Finalizing Report and Presentation								X

Figure 14 Project Schedule

Methodology

This chapter explains the methodology the design team utilized during the project based on the project goals and objectives.

A project methodology is a series of methods and processes that should be followed by the project team in order to deliver a high rate of success and to realize the goals and objectives.

Corresponding to each of the objectives, four steps of methodology were generated in order to complete the project.

A visual representation of the project methodology is shown in Figure 15.

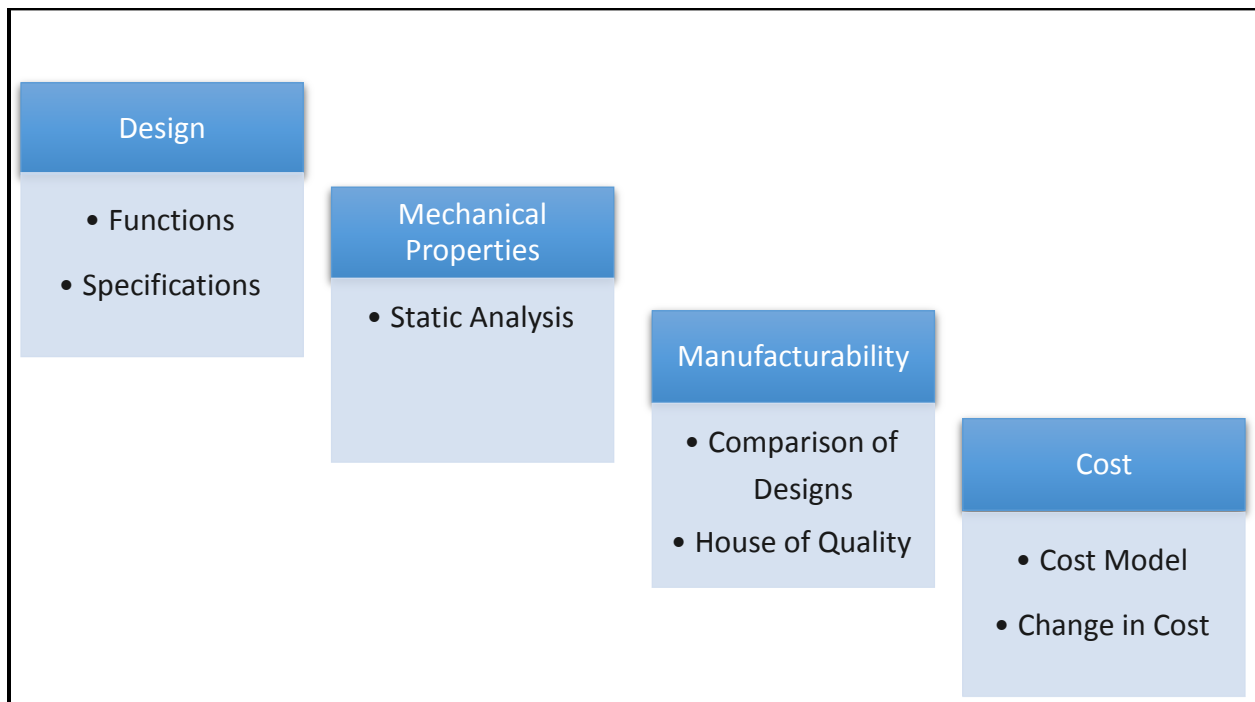

Figure 15 Project Methodology

Design Functions

The first step in beginning this project was to obtain design requirements, or so called customer needs, and design specifications from the project sponsor. The current parking brake system used in Caterpillar machines has a set of standards that the new design must abide. The required specifications give the project more definition in terms of what needs to be done and how should it be done. This helps in avoiding Type III error that is working on the wrong problem. Once specifications are compiled with proper details, this project can be more comprehensive and readily achievable.

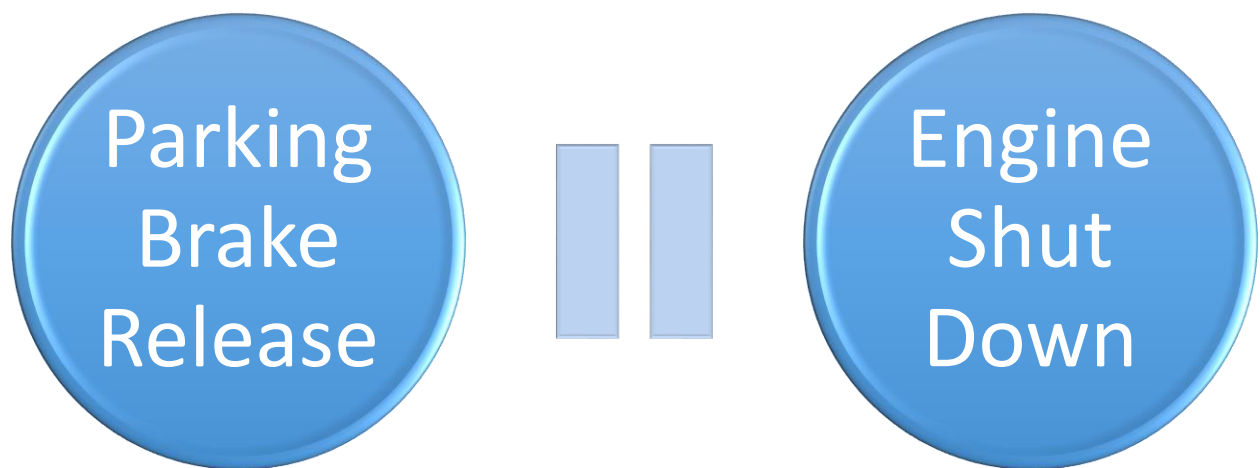

Figure 16 Design Functions

The sponsor required the project team to design a mechanism that was able to realize two functions, namely parking brake releasing and engine shutdown. (Figure 16) The two functions should happen simultaneously. A tow hook was suggested by the sponsor to be used in the design in order to realize the two functions instead of using the two separate switches used in the previous design. As described in the previous sections, a transmission override switch equipped on the SMA was used to shut down the engine when emergencies happen.

Items	Parameters
Tow force	24 KN
Fatigue Limit	100 (Number of uses per lifetime)
Working temperature	1200 Degrees C
Implementation Space	Unknown
Maximum Pull Angle	20 degrees

Figure 17 Specifications List

Design specifications were critical in the design because they were used to determine the limitations of the design. As it was described by the sponsor, the working temperature for 980H wheel loader with SMA is around 1,200C. Since the PBR system is only used when emergencies happen, the fatigue limit was not required to be high and was set to be 100 uses per lifetime. The implementation space is not given a specific value. The maximum pull angle was 20 degrees.

Mechanical Properties

After generating several design options, static calculations would ensure the design has a good manufacturability, reliability, and safety. Those calculations include stress and strain calculation, deflection calculation, and maximum force calculation. In order to perform these calculations, certain software packages were required to be mastered. These software packages were examined in Software Overview section in the Background.

For any mechanical design, maximum loads have to be determined since they can impact the design dramatically. Maximum loads usually deal with stress, moments, and shear forces applied to the structure. By calculating those forces, it is possible to determine the material required. Also, such calculations indicate where might the design fail, or what parts of the design that should be reconsidered.

For this project, the static forces that have to be accounted for are the weight of the machine and whatever loads it may carry. The design also has to satisfy the requirements for maximum loads. However, maximum loads calculations do not account for dynamic forces which, too, need to be established and configured to the specifications.

Manufacturability

Manufacturability consists of material selection and design. In order to have good manufacturability, many important concepts need to be considered. In this case, these concepts are customer needs and engineering requirements.

After the stage of conceptual designs, comparison of designs would be needed to choose the optimal design. The characteristic of each design would be presented. After measuring the effectiveness of each design, scores of each customer needs would be given to the designs. Getting feedback from the project sponsor would be useful in the process.

Customer needs are general characteristics customers require mechanical designs to have. In this case, new design was required to be safe, stable and to have operation simplicity and good manufacturability.

Engineering requirements are the characteristics of the design determined by the design team to realize the customer needs, or, in other words, how the project team was going to satisfy the company's requirements. The design should make the PBR system easy to operate, thus requires the interface ease of use. The new design is required to have a good manufacturability and the manufacturing process should be easy. Also materials were needed to be carefully selected to make the manufacturing process easy and reduce the cost of the new design. The design can vary significantly due to the materials selected. Easy manufacturing process would ensure that the design was financially attractive. Since scales are built into the lift arms to allow on-the-go weighting of material, operators load trucks more accurately and efficiently. Payload Control is available as a factory-installed option.

To ensure that the design had a good manufacturability, a house of quality was needed to measure the design parameters and to be used as a platform for communication with the project sponsor. A house of quality was designed to measure the relative importance of each engineering requirements and define the relationship between customer needs and engineering requirements. Also, the HOQ was used as a platform to communicate with the sponsor. The project sponsor rated all the customer needs in order to quantify the design parameters. It is noteworthy to mention that safety and stability were given the highest weights. Numbers in the columns are the relationship between customer needs and engineering requirements. The sum of the product of each customer needs and engineering requirements was the relative value of one engineering

requirement in the design. As seen in the following diagram, payload linear control was found to have the highest importance.

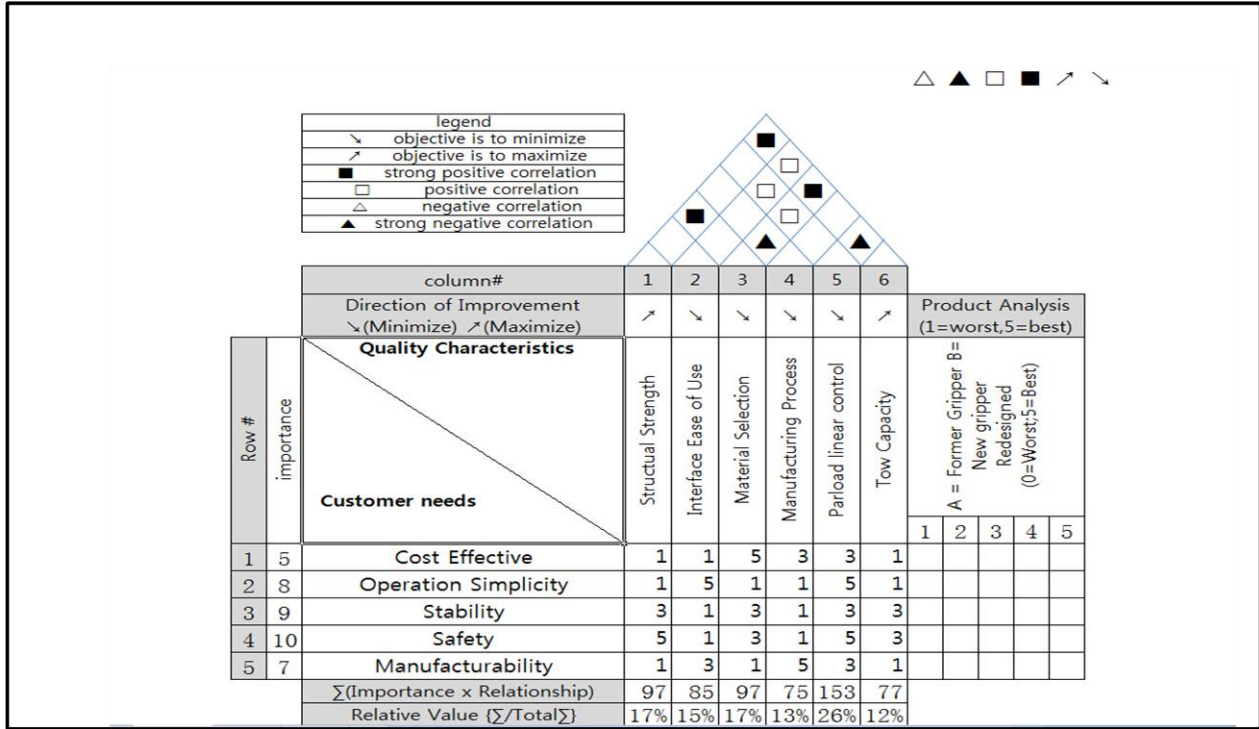

Figure 18 House of Quality

Cost

Since implementation would not take place in current vehicles, the next generation wheel loaders would be the first to potentially implement the new design of the parking brake system. This meant that a thorough cost analysis was needed for this new design. This analysis would include manufacturability as one of the main costs of this project because it could be very costly if the design was not optimized in all possible means. This includes the materials used and the process of manufacturing each part of the system as well as assembly. More details are covered in the Cost Analysis Chapter.

Ethics

Ethics are the basis of any experiment. Projects that do not consider the code of ethics in their doings are destined to failures sooner or later. Without ethics, not a project will be successful. Therefore, the code of ethics was followed in doing this project. The National Society of Professional Engineers has compiled the fundamentals of ethics for engineers. They are as follow (NSPE CODE OF ETHICS FOR ENGINEERS, 2014):

- Hold paramount the safety, health, and welfare of the public.
- Perform services only in areas of their competence.
- Avoid deceptive acts.
- Conduct themselves honorably, responsibly, ethically, and lawfully so as to enhance the honor, reputation, and usefulness of the profession.

Those fundamental concepts were the most that relate to this project. They were taken under consideration in achieving the goal of this project.

Designs

In this section, the approach that was taken to create designs is explained as well as the designs and the design stages. At first, many design ideas were sketched and then modeled using SolidWorks. The team decided that sending sketches of 3D models to the sponsor would make for better communications. That was true since we received critical feedback that gave the project more definition. However, sending 3D models cost the team many working hours but it was justified when the feedback was obtained. Based on the feedback, the team selected two designs to revise. After revising the two designs, the team reached the last stage of the design process, which was the final designs.

Design Ideas

The team began the project using the initial specifications that we were given from the sponsor. The specifications were very abstract and only included a general description of the functionality of the expected designs. Based on the initial description, the team created many sketched but decided to model only four that had very distinctive approaches to the problem. Those four models (abbreviated in DI 1 to DI 4) are explained below.

DI 1

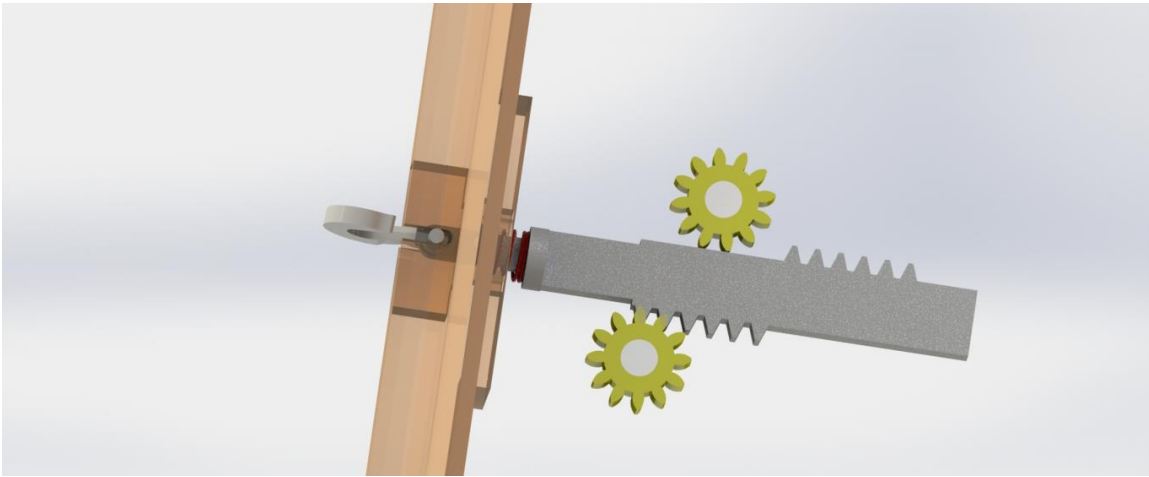

Figure 19 Design Idea 1

In this model, the team used two gears, a shaft, a spring, and a hook. The hook is directly connected to the shaft. The spring is installed on the shaft to limit the movement of the shaft, and also to reset it. The two gears are for triggering the parking brake release (PBR), and engine shutdown. The different placement of the two gears allow for time delay between each of the functions. Once the tow force is applied to the hook, the spring compresses and a linear translation happens along the shaft. This causes the gears to rotate which eventually realizes the required functions. When the towing force stops, the spring returns to its initial state and the system is restored.

DI 2

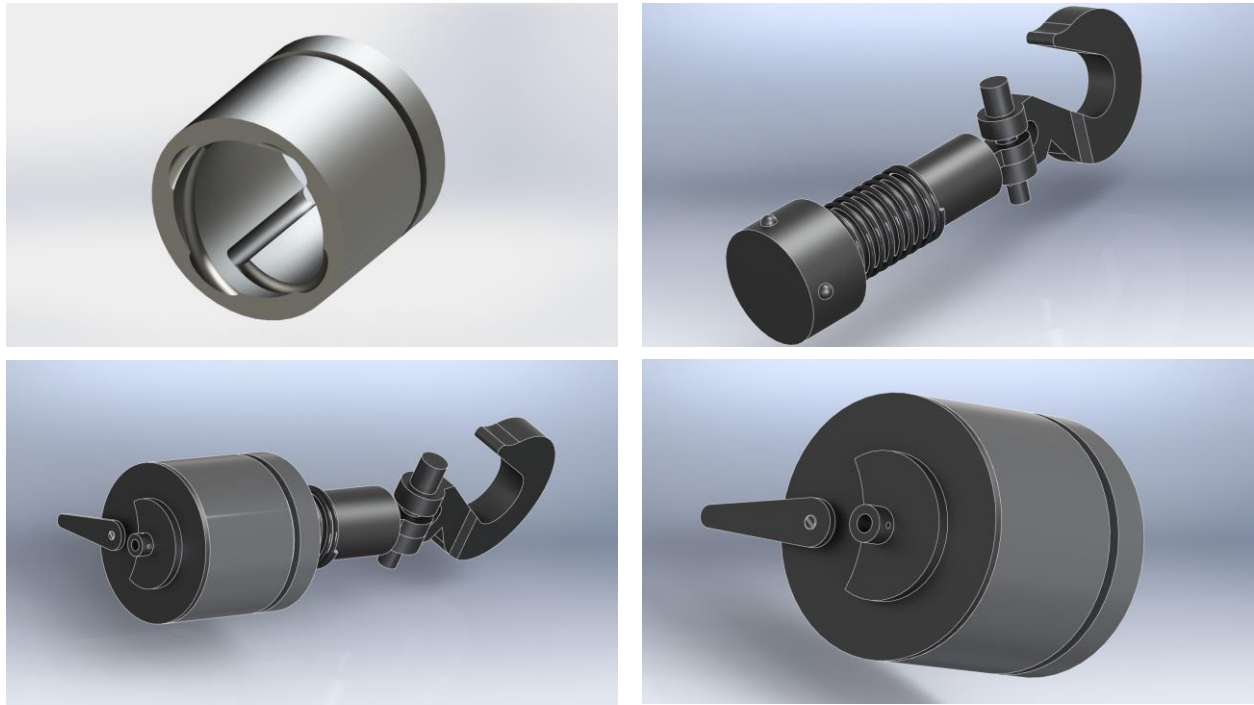

Figure 20 Design Idea 2

This design uses many parts including a hook, a steel rod, a spring, and a special pipe with threading. The pipe is used as a socket and is free to rotate. The end of the rod has a sticking out piece that is designed to trigger the engine shutdown. It also has a hole in the center that is designed for a steel wire to go through to control the PBR. By applying the tow force, the end of the rod forces the pipe to rotate at first to shut down the engine through the fixed piece at the end of the rod. When the tow force continues, the rod moves in a straight line, which pulls on the steel wire to activate the PBR. When the tow force is discontinued, the spring restores the entire system first by moving along the special threading in a straight line then rotates back in place.

DI 3

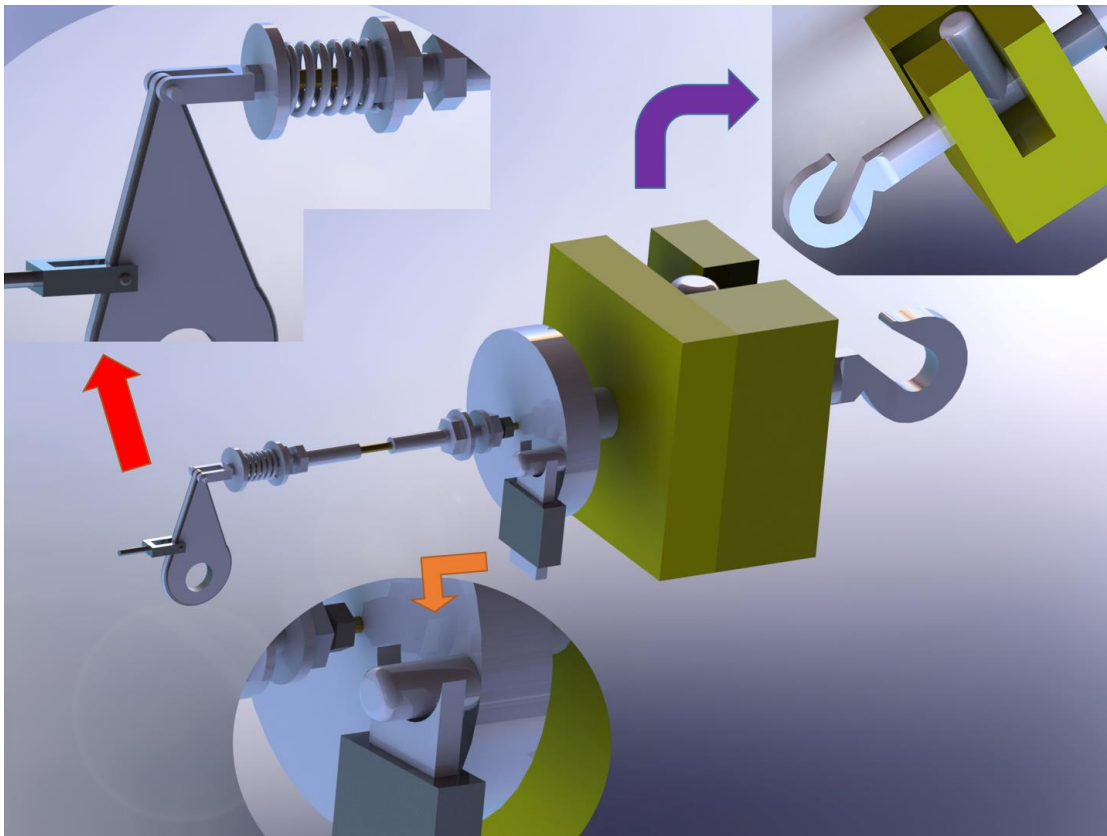
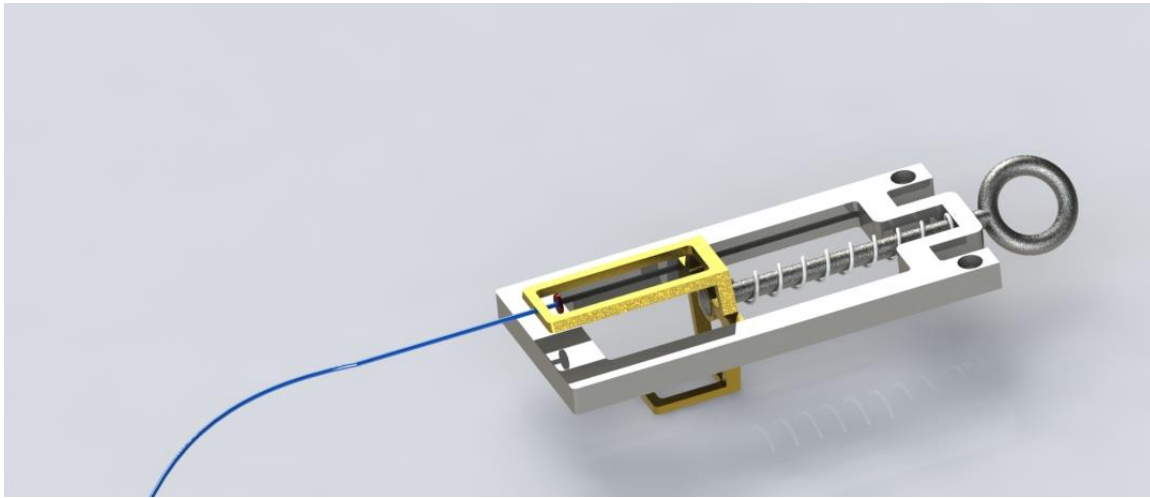

Figure 21 Design Idea 3

This design utilizes many components including a lever, a spring, a hook, and a travel switch. Also there are several parts that are used mainly to give support to the mechanism. The lever is used to trigger both the parking brake releasing while the travel switch is used to shutdown the engine. This design requires that before applying the tow force, the tow hook have to be rotated. By rotating the hook, the travel switch is activated first and the engine is shutdown. Once the tow hook is rotated, the hook can be pulled to activate the PBR through the lever. When the tow force is stopped, the spring rests the hook. Then the hook has to be rotated manually back in place.

DI 4



This model uses a steel cable, a hook, a spring, and a mechanical slide. The steel cable functions similar to the knob used inside the cabin. The hook and spring are used to withstand the applied force. By pulling on the hook, the spring compresses and a linear translation is carried by the slide to trigger the steel cable. When the force is discontinued, the spring restores the system, and the parking brake releasing is deactivated.

Comparison between Design Ideas

Shortly after the design ideas were sent to the sponsor, a detailed feedback was received. The feedback was discussed among the design team, and new specifications were considered for the next stage of the design process. The following table summarizes the feedback received:





Designs Criteria	Conceptual Designs				
	Characteristic	Gear and gear track	Sleeve with special guideway	Different radius control two functions	Torsion spring and cable
Cost effective	5	1	5	5	
Operation simplicity	4	4	4	4	
Stability	1	1	4	3	
Safety	3	3	4	4	
Manufacturability	5	1	5	3	
Score	18	10	22	19	

Figure 22 Design Ideas Comparison

Also specific comments were given by the sponsor for each of the designs. For DI1, the main problem is that the system is very hard to clean and protect from dirt and dust. Additionally, the gears structure is unreliable for the environment that the 980H operates under. For DI2, it is difficult to manufacture because of the many components as well as the special threading that is required. As a result, this design is considered complicated and unreliable by the sponsor. For DI3, the connecting parts are easy to obtain, which makes the design easy to be manufactured. However, the team was asked to skip the rotating feature, and uses the lever for both functions. For DI4, it is easily manufactured but had cleaning and maintenance problems caused by the slide. The team also asked the sponsor to rank the four different designs. The following table shows the rankings:

Designs	Rank
DI 1	3rd
DI 2	4th
DI 3	1st
DI 4	2nd

Figure 23 Table of Design Rankings

The sponsor recommended revising DI3, and also creating an alternative design. The team considered the feedback and the recommendations for the next stage of the design process.

Selected Designs

For this stage, the team selected DI3 to revise and implement the recommendations given by the sponsor. Also the team worked on an alternative design that considers all the collective comments received from the sponsor. Therefore, the team had two designs for this part of the design process, and they are explained below.

Design One

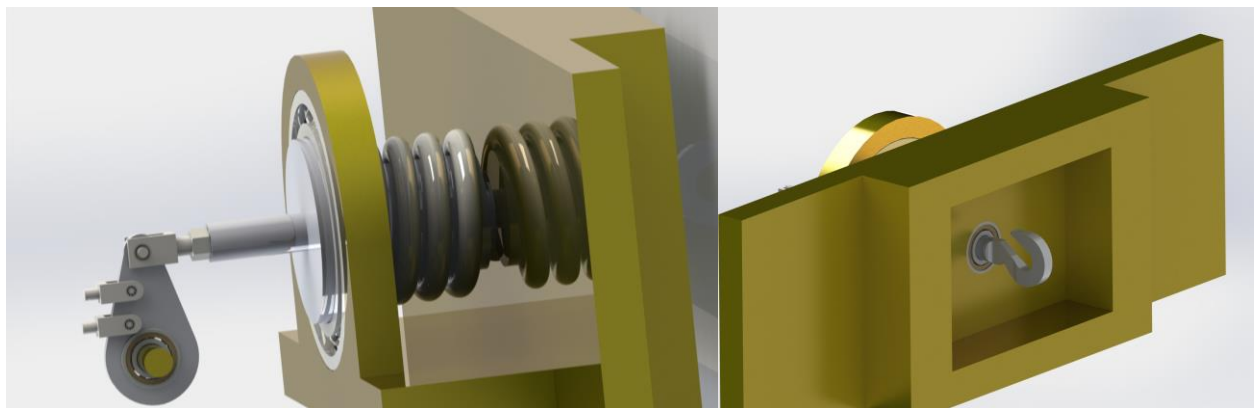

Figure 24 Selected Design 1 - Overview

This design is a revised version of DI3. The rotation feature was eliminated, and instead another trigger was added to the lever to realize the engine shutdown function. The next figure shows how this design works in more details.

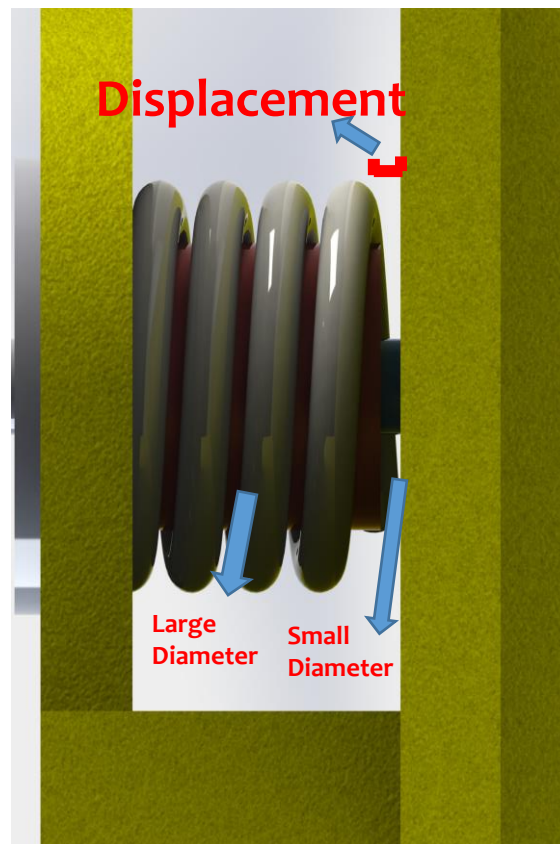

Figure 25 Selected Design 1 - Spring

When the hook is pulled, a small displacement occurs along the rod. The rod is connected to another cylinder with a larger diameter. The spring compresses until the bigger cylinder touches the main body of the 980H wheel loader. This allows for a better support to the spring since the towing force would be shared between the spring, the larger cylinder and the main body of the machine. The linear movement along the rod is then translated to the cable that is connected to the lever. As a result, the lever rotates which causes the triggering of the PBR and

engine shutdown via the two smaller cables connected on the other side of the lever as shown in Figure 26.

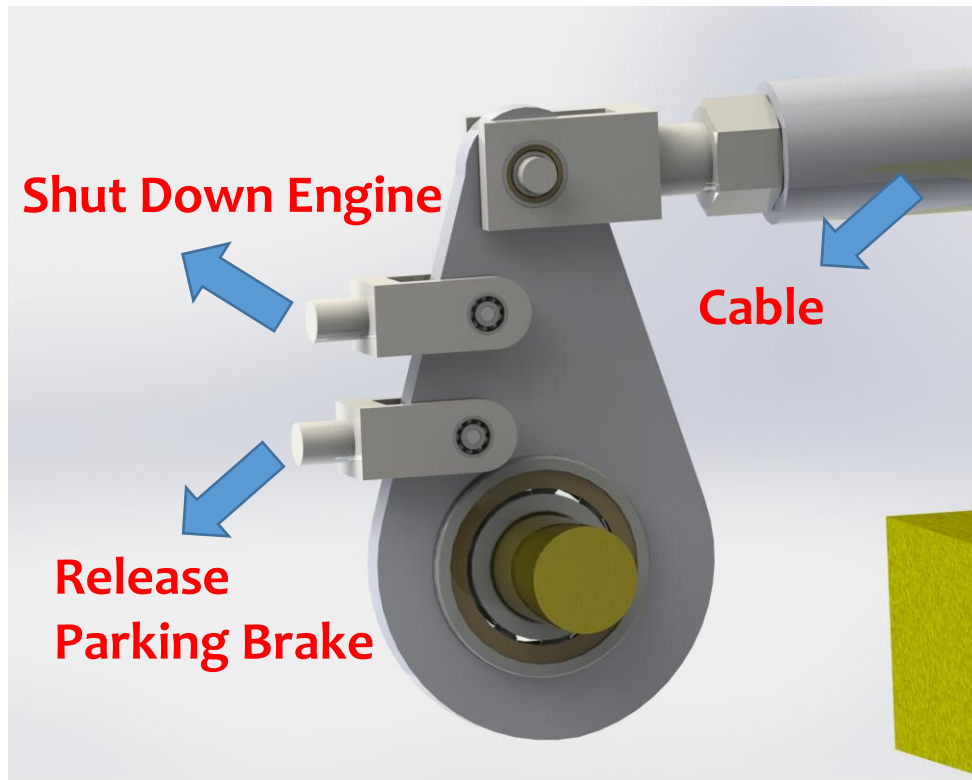

Figure 26 Selected Design 1 - Lever

The use of the lever allows having a fixed delay between the triggering of the two functions, which is another requirement that the team has received from the feedback.

Design Two

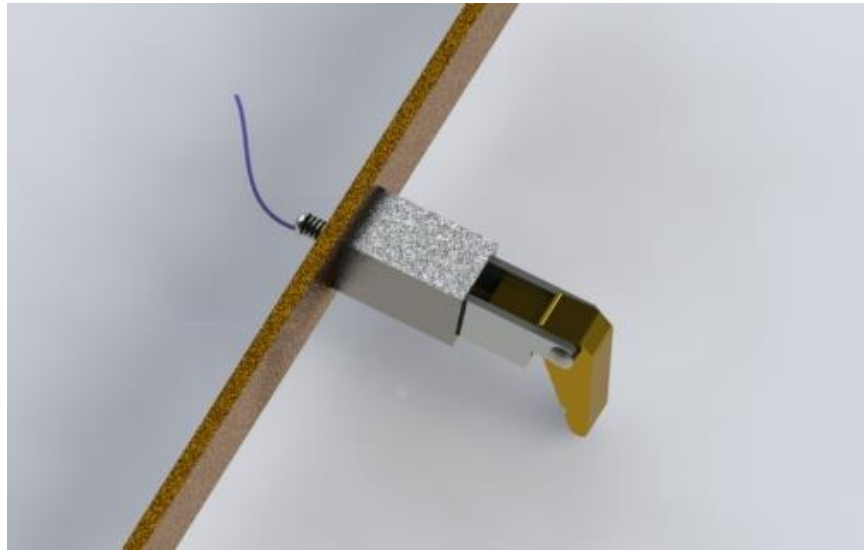

Figure 27 Selected Design 2 - Overview

Figure 27 shows an overview of the new design that was created based on the collective feedback. The team communicated with the sponsor regarding this design since it was a new idea and was not presented in the design ideas. As a result, more feedback was delivered and considered in this model.

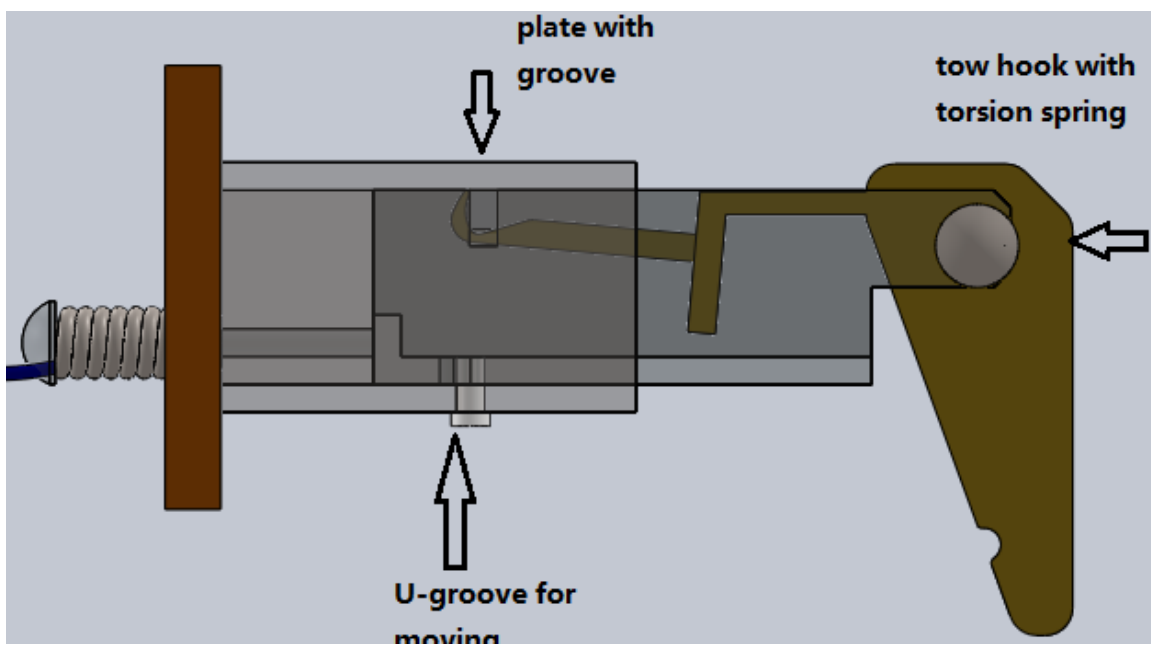

Figure 28 Selected Design 2 - Inner Structure

Figure 28 shows the inner structure of the design. One of the main parts that were changed was the hook. Previously, the team used a conventional hook. However from the more recent feedback, the hook was changed to be more suitable for towing by another vehicle using the bucket, likely a scraper pan. The hook is also designed with a special opening for towing with steel wire. When the tow force is applied, the hook rotates for until it is released from the stopping plate, and secured to the main body of the design. Then a small linear displacement is allowed by the U-groove, and translated to the compression spring. The spring is connected to a wire that is responsible for triggering both functions. When the force is no longer applied, the compression spring acts first to pull the hook back in place. Then the torsion spring secures the hook to the fixed plate.

Final Designs

For the last step of the design process, the team needed to consider the most recent feedback to apply on the first selected design, as well as perform some numerical computations to improve the final designs. Autodesk Inventor was used to carry some numerical tests to validate any final modifications to the designs.

Final Design – One

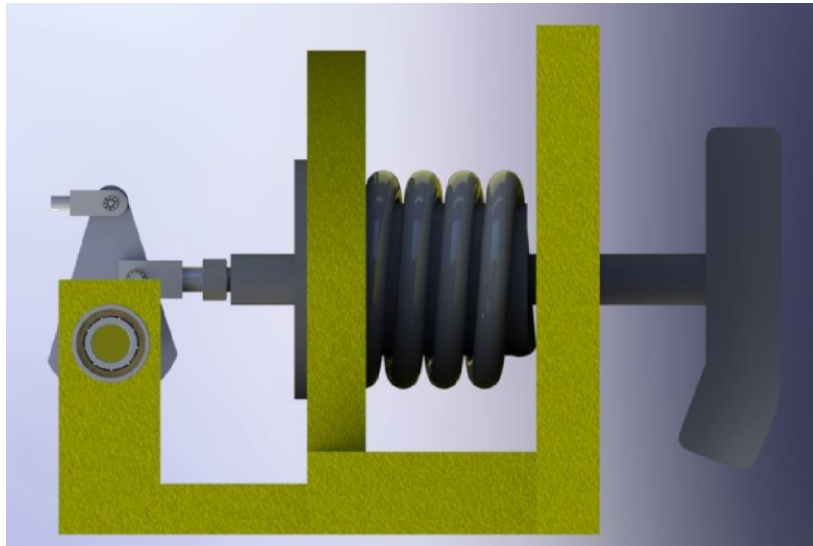

Figure 29 Final Design 1 - Overview

There are two main changes that were made to this design. The first is the hook as seen in Figure 30.



Figure 30 Final Design 1 - Hook

The hook was changed to be suitable for towing by cables as well as other vehicles' buckets. Figure 31 shows the other main modification for this design.

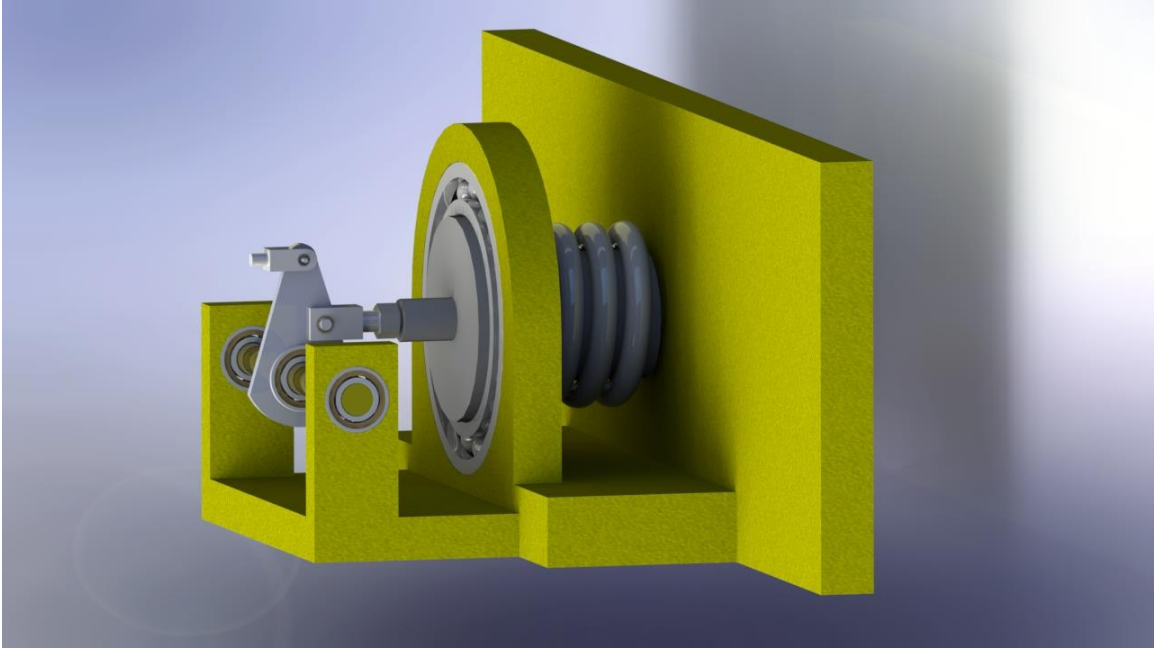

Figure 31 Final Design - Modification

The latest feedback suggested that one trigger can realize both functions, and that there is no need to have two separate triggers for each function. Also the sponsor stressed that the movement of the hook must be very small, and estimated it to be about 6 mm. As a result, the trigger cable was moved to the top of the lever, and the cable connecting the hook to the lever was moved to the middle of the lever. Therefore, the displacement for the triggering cable is maximized.

Final Design – Two

For the second design, two things were changed based on the graphs generated by Autodesk Inventor. When the model was imported to the software, a series of tests were performed. The most relevant test was the displacement test, which revealed some weakness in the design. The first weakness was the inner end of the hook that is secured to the fixed plate. Therefore, that part was corrected by replacing it with a more standard geometry.

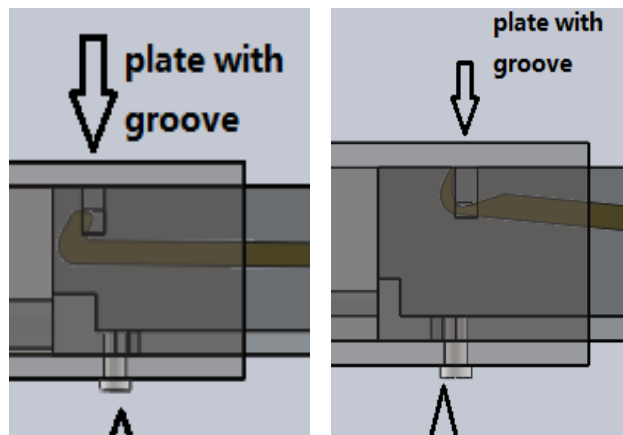

Figure 32 Final Design 2 – Modification 2

The other weakness can be seen in the graphs obtained from Autodesk Inventor.

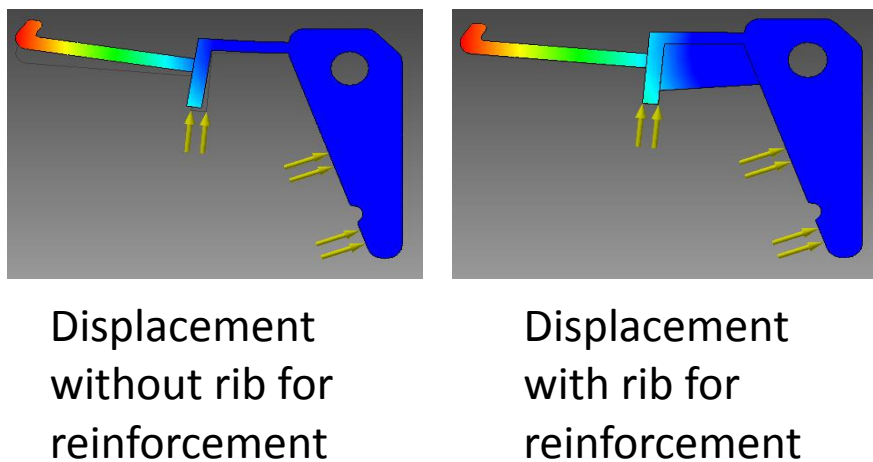

Figure 33 Final Design 2 – Modification 2

After performing the displacement test on this design, the team realized that there is too much displacement concentrated on the securing rod. Therefore, a rib was added to the design for better support. After adding the rib, the design has a better displacement distribution on the structure.

The final version of the second design is shown in Figure 34.

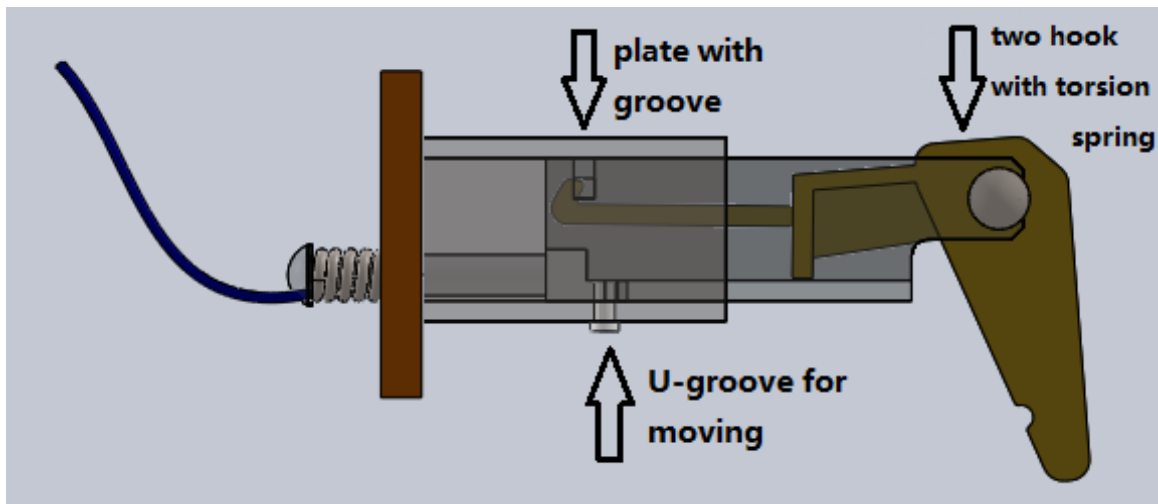

Figure 34 Final Design 2 - Overview

Selection of Final Design

Due to time limitations, the team had to select one of the two final designs to validate its mechanical properties by applying Finite Element Analysis (FEA). For the team to do so, the team first asked the sponsor for more feedback to assist in the selection. Then, a table showing the pros and cons of the two final designs was created based on the feedback and the comments of the design team. The table is shown below.

Design One		Design Two	
			
Pros	Cons	Pros	Cons
One-step to operate	The hook	Suitable for scraper pan	Harder to manufacture
Design parts are easy to obtain	-----	More secure against oscillations	Requires more connecting parts
Easily manufactured	-----	More secure against accidental triggering	-----
Displacement for Triggering is increased	-----	-----	-----

Figure 35 Table of Final Designs Comparison

After considering all the factors mentioned in the table above, the team considered continuing with Design One for several reasons. One of them is that Design One was favored by the sponsor for its simplicity and manufacturability. As a result, the detailed calculations were based on Design One.

Calculations

This chapter covers the basic calculations that were made to establish the input specifications used in Autodesk Inventor. It also explains the FEA results including the different tests applied to Design One.

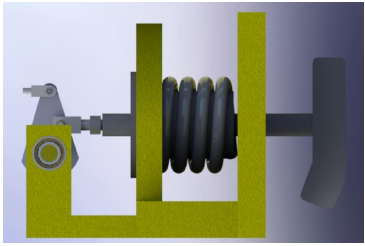
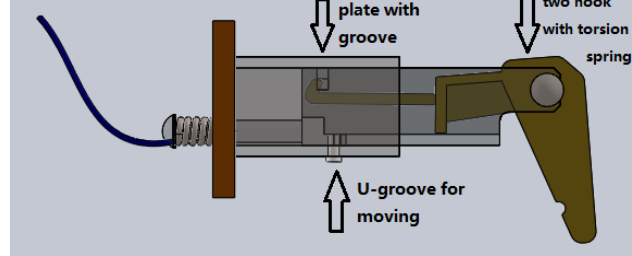
Tow Force Calculations

The most essential number that had to be calculated is the tow force that is applied to the hook. The tow force is directly related to the friction force since the tow force has to cancel out the friction force for the vehicle to start moving. Therefore the friction force and the tow force are equal and opposite. This is why the friction force was calculated first by the equation shown below.

$$F_f = \mu N = \mu(mg)$$

where:

F_f is the friction force.

μ is the friction coefficient.

N is the normal force

The team had to establish some assumptions based on research since the team could not have access to this kind of information from the sponsor. However, the team was encouraged to use an educated guess for the missing information, mainly the friction coefficient. So after extensive research, the team decided to use a friction coefficient of 0.8 that is the friction value between rubber and dirt with concrete (Friction and Coefficients of Friction, 2014). The normal force is equal to the weight of the 980H wheel loader, which is 30 tons. So the calculations yield the following tow force:

$$F_f = \mu N = (0.8)(30,000)N = 24 \text{ KN}$$

Therefore, the towing force was calculated to be 24 KN. This value was then used as one of the inputs for the Finite Element Analysis.

FEA of Design One

In this analysis, three tests were applied to design one. Each test calculated a certain property and gave insight on how to better the design. However, this analysis was added only to give more insight for future recommendations since time was limited. The first test is used to measure the stress on the structure as shown in Figure 36.

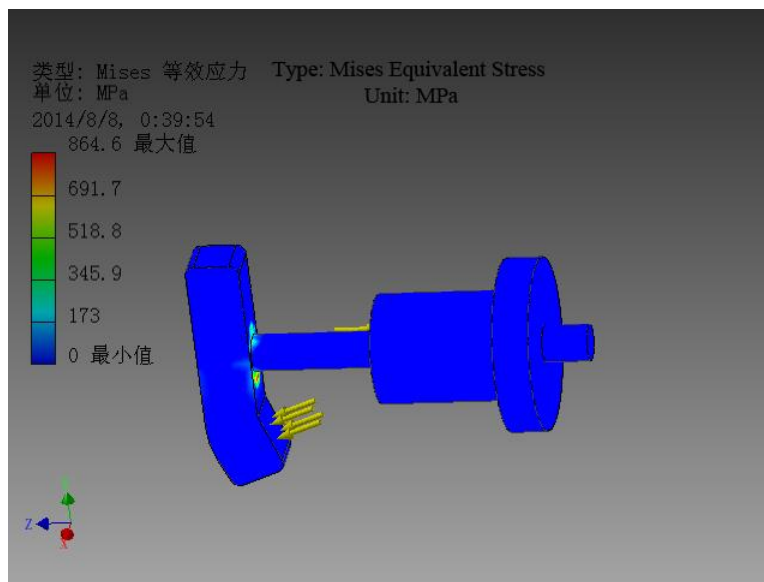

Figure 36 Final Design 1 FEA - Stress

The figure shows that there are a few spots around the connecting joint between the hook and the rod with higher stress values. This happens when applying the tow force on the bottom of the hook where the yellow arrows are pointing. This tests shows that the entire structure is in

good condition regarding stress except for a few areas where adjustments to the structure might be useful.

The second test was to measure the displacement that occurs when the tow force is applied in the same location as the first test, notated by the yellow arrows.

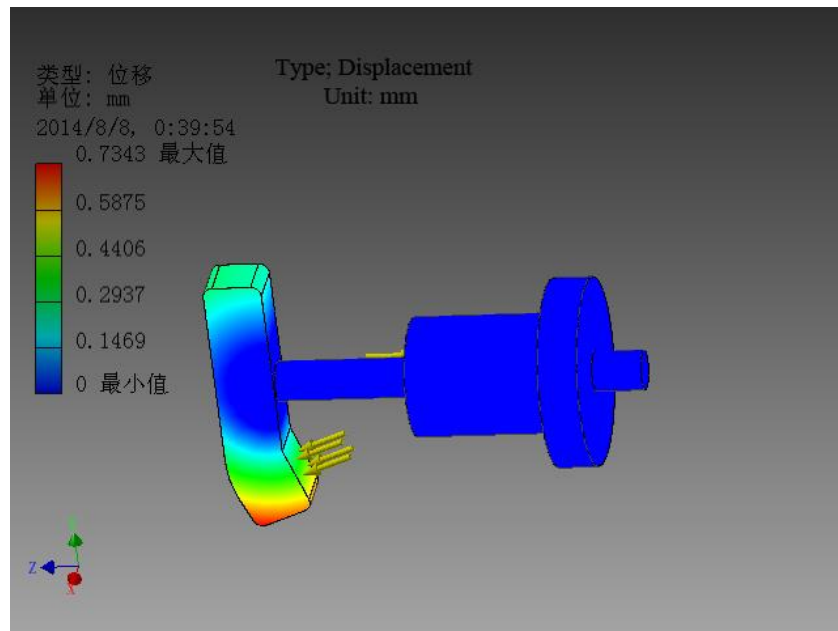

Figure 37 Final Design 1 FEA - Displacement

This graph illustrates the distribution of force and the displacement that occurs as a result. As expected, the highest value for displacement is 0.7343 mm and occurs at the bottom end of the hook. This suggests that the hook might have some wear and tear around the edges. Also the displacement value is considerably high at both of the hook ends.

The third test is called the safety factor test. It is designed to measure the ratio between the structural strength to the applied load. A high safety factor means a stronger structure. Figure 38 shows the results from the safety factor test applied to Design One.

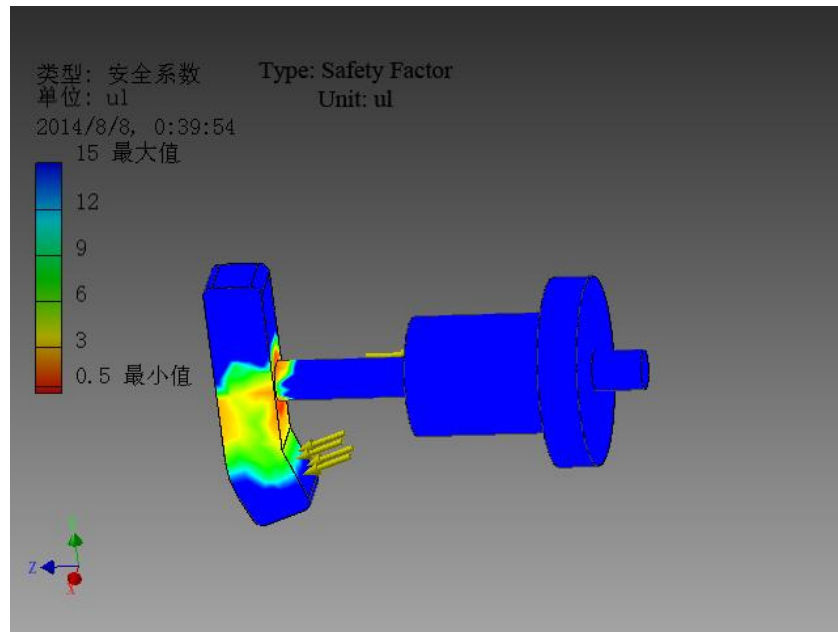

Figure 38 Final Design 1 FEA - Safety Factor Test

The test shows critical areas where the safety factor is less than one. This means that the structure is more likely to fail in those red areas. This might cause a necking between the hook and the rod that quickly leads to a system brake/failure. It is also very concerning to have very low values for the safety factor test. The team's expectations were that the lowest value for the safety factor should be 6. However, this graph also shows that there is room for improvements on the structure.

Design Recommendations

This chapter concentrates on the design flaws that were discovered after applying FEA to Design One, and some possible solutions. When evaluating Design One, the team found that the major issues were the shape of the hook and the connection between the hook and the rod. For those two issues, the team explored many solutions from which the team collected a few recommendations for future groups.

Regarding the necking issue that might be a great concern when dealing with applications like this design, the team recommends that the connecting end of the rod should be reinforced. Figure 39 shows where the reinforcement should be implemented.

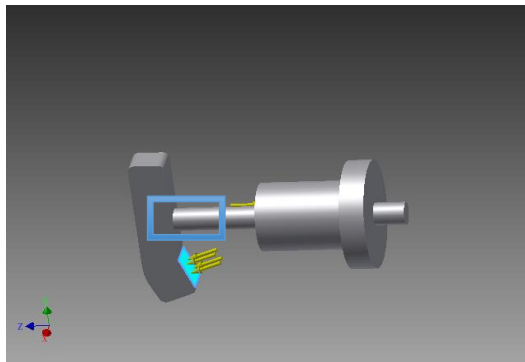

Figure 39 Reinforcement

The reinforcement should be where the blue box is. As a result of the implementation, the force will be distributed on a larger area, which would reduce stress and increase the safety factor. It is also important to consider the manufacturing process. Welding parts together should be avoided; instead the rod should be machined to the specifications.

The other problem is the hook itself. The hook needs to be more suitable for towing by a cable as well as towing by another machine's bucket. Design One could use some of the features

offered by Design Two, particularly the shape of the hook. Alternatively, a new hook can be designed and tested with FEA, simultaneously, to improve on Design One.

Cost Analysis

This chapter analyses the cost may be incurred during the manufacturing process, including labor and materials cost.

Proper maintenance of a wheel loader can help control the maintenance and operating costs. Caterpillar provides convenient customer services which save customers maintenance costs. The new pure mechanical designs were reliable systems with simple connecting parts and would decrease probability of an emergency. Therefore, high maintenance cost would not be incurred.

The new design eliminated the original hydraulic system. The pure mechanical system made the design easy to be constructed, and reduced the assembly and implementation cost. A hydraulic system uses pumps and valves, which are complicated and expensive components. Also, oil flows through the system, which makes it more difficult to ensure the reliability of the system.

The cost of the PBR system on a 980H wheel loader could be significantly reduced by a pure mechanical design. Accumulator, hydraulic pump, and hydraulic valve are the three components that made the original design costly. According to the information provided by the project sponsor, an accumulator cost about \$2,000, and a hydraulic pump or valve cost around \$200 to \$500.

Though the project sponsor did not require a detailed cost analysis, it was still necessary to show that the new design would not increase the cost compared to the original one. However, only the manufacturing cost was measured in this process because it could be very costly if the design was not optimized in all possible means.

In general, manufacturing cost is the cumulative total of resources that are directly used in the process of making goods and products. Overall manufacturing cost mainly consists of direct materials cost and direct labor cost. Manufacturing overhead is ignored in this process. Design One was picked to conduct the cost analysis because it was preferred by the project sponsor.

The calculation result of direct materials cost is shown as follow:

No	Part	Materials	Semifinished size (mm)	Number/semi finished	Cost
1	Cam	Stainless steel	200X200X10	1	30\$
2	Locating Pin	Stainless steel	Cylinder diameter 20,length 50	2	10\$
3	Bearings	Alloy steel	Standard parts	7	70\$
4	Hook	Forged steel	Cylinder diameter 200, length 400	1	50\$
5	Wire	Alloy steel	Diameter 20, length 100	1	10\$
6	Nuts	Alloy steel	Standard part	1	1\$
7	Spring	Alloy steel	Standard part	1	30\$
Total	200\$				

Figure 40 Direct Materials Cost

Six kinds of parts were used in Design One, some of them with more than one piece. The materials used and semi-finished size for each part was determined by the designer himself based on the principle of optimal effectiveness. The cost of each part was determined based on prices provided by online business websites. Compared to the original design, which cost more than \$2,000, the cost of the new design was obviously reduced.

The result of the direct labor cost calculation is shown as follow:

No.	Part	Process	Working hours	Process cost
1	Cam	milling	1	30\$
2	Hook	forging, machining	2	100\$
3	Locating pins	machining	1	10\$
4	Spring	purchasing	0	0
5	Nut	purchasing	0	0
6	Bearing	purchasing	0	0
7	Wire	purchasing	0	0
Total	140\$			

Figure 41 Direct Labor Cost

Manufacturing process of each part was determined by the design team and then online price research was conducted. Since some of the part was more beneficial to purchase on markets instead of manufacturing by the company itself, the labor cost of parts no 6. To no.8 were calculated based on the market prices provided by the HUST Manufacturing Center. For the other parts, with the help of the HUST Manufacturing Center, the manufacturing process of each part was determined. Then, based on the manufacturing processes, the machine needed to manufacture each part and working hours were determined. Total direct labor cost, the sum of the labor cost of each part, would be \$140.

As shown, the total manufacturing cost would be \$340. The accumulator equipped on a 980H cost about \$2,000. Therefore, the design itself saves about \$1,660.

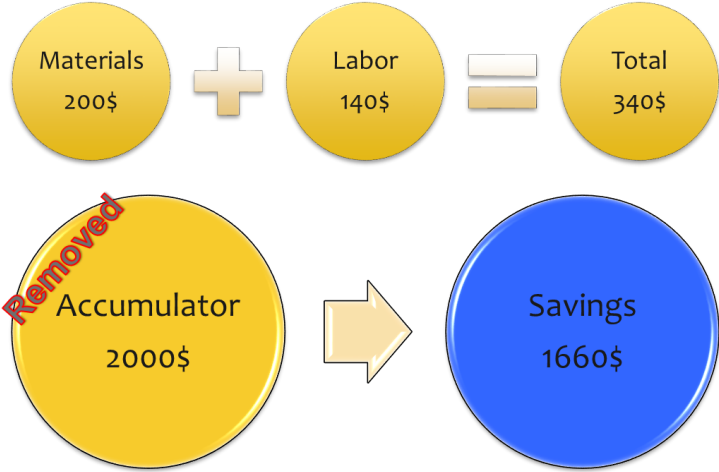

Figure 42 Cost Reduction

Results

This project has provided Caterpillar more than one reliable and cost-effective design solutions for the PBR system on the 980H wheel loader. The final designs could both perfectly realize the functions required: releasing the parking brake and shutting down the engine. Successfully eliminating the original hydraulic components used in the original design, the two designs were both pure mechanical, which meant that no hydraulic or electrical parts played a role in the new designs. The main goal of this project was to eliminate expensive hydraulic parts in order to generate one or more financially attractive solutions.

The reliability and the simplicity of the PBR system were two important concerns. Using pure mechanical systems, the two final designs reduced the probability of safety hazards such as oil leakage, hydraulic power loss, and casualties. With a newly equipped tow hook, a great improvement in the field of hauling disabled machine was made: the new way of releasing the parking brake in the event of an emergency prevents people from getting too close to the disabled machine and the towing process can be performed with the operator sitting safely in the cab.

During the project, the design team strived for good manufacturabilities of the new designs. All customer needs were carefully reviewed. In order to meet them, engineering requirements were generated. The design team created a House of Quality to assess the relationships between those requirements. With the help of the project sponsor, Dany Dong, the importance of the factors were determined and emphasized throughout the design. Therefore, when some of the engineering requirements were contradictory with each other, more important features could be placed in priorities in order to ensure a good manufacturability. Static calculations were

performed successfully after the design process. They assessed the reliabilities of the designs with the limitations of the design requirements. Those calculations were precise and represented the requirements accurately.

In conclusion, this project successfully met the project sponsor's requirements, was guided with a good communication between the design team and the sponsor, and was based on professional ethics codes. Potential future improvements on the designs may be needed depending on the project sponsor's need. For those probable demands, some conceptual design ideas have been provided and can be the bases for future designs.

References

Hodge, Norman J., and John W. Bridwell. "Patent US3985210 - Automatically Engaged Emergency Parking Brake." Google Books. N.p., n.d. Web. 01 Sept. 2014. . <
<http://www.google.com/patents/US3985210>>

"Caterpillar | Caterpillar." Caterpillar | Caterpillar. N.p., n.d. Web. 01 Sept. 2014. . <
<http://www.caterpillar.com/en.html>>

"Wheel Loaders." Cat. Caterpillar, n.d. Web. 01 Sept. 2014. . <
http://www.cat.com/en_US/products/new/equipment/wheel-loaders.html >

Specalog for 980H Wheel Loader, AEHQ5631-04. N.p.: n.p., n.d. Web. 1 Sept. 2014. . <
<http://s7d2.scene7.com/is/content/Caterpillar/C734414>>

"CONSTRUCTION EQUIPMENT." CONSTRUCTION EQUIPMENT. N.p., n.d. Web. 01 Sept. 2014. <
<http://wheel-loader-blog.blogspot.com/>>

"PTC Creo Elements/Direct Modeling Express 6.0." Technology Solutions for Ongoing Product & Service Advantage. N.p., n.d. Web. 01 Sept. 2014. . <
<http://www.ptc.com/product/creo/elements/direct-modeling/express>>

"What Is ANSYS." What Is ANSYS. N.p., n.d. Web. 01 Sept. 2014. . <
<http://www.figes.com.tr/english/ansys/ansys.php> >

"SolidWorks Premium | SolidWorks." SolidWorks Premium | SolidWorks. N.p., n.d. Web. 01 Sept. 2014. . <
<http://www.solidworks.com/sw/products/3d-cad/solidworks-premium.htm>>

"3D CAD Software for Mechanical Design." 3D CAD Software. N.p., n.d. Web. 01 Sept. 2014. . < <http://www.autodesk.com/products/inventor/overview> >

"NSPE CODE OF ETHICS FOR ENGINEERS." JOM-JOURNAL OF THE MINERALS METALS & MATERIALS SOCIETY 45.4 (1993): 14-6. Web. 1 Sep. 2014. .

"Friction and Coefficients of Friction." Friction and Coefficients of Friction. N.p., n.d. Web. 30 Aug. 2014. . < http://www.engineeringtoolbox.com/friction-coefficients-d_778.html >