

May 2010

# Research in Artificial Intelligent Tutoring

Christopher Michael Kevorkian  
*Worcester Polytechnic Institute*

Daniel Van Moyer  
*Worcester Polytechnic Institute*

Peter Calvin Costello  
*Worcester Polytechnic Institute*

Follow this and additional works at: <https://digitalcommons.wpi.edu/iqp-all>

---

## Repository Citation

Kevorkian, C. M., Moyer, D. V., & Costello, P. C. (2010). *Research in Artificial Intelligent Tutoring*. Retrieved from <https://digitalcommons.wpi.edu/iqp-all/187>

This Unrestricted is brought to you for free and open access by the Interactive Qualifying Projects at Digital WPI. It has been accepted for inclusion in Interactive Qualifying Projects (All Years) by an authorized administrator of Digital WPI. For more information, please contact [digitalwpi@wpi.edu](mailto:digitalwpi@wpi.edu).

# The Effectiveness of Hints in ASSISTments

Peter Costello, Christopher Kevorkian, and Daniel Moyer

Worcester Polytechnic Institute

## Contents

Abstract	3
Background	3
Description of ASSISTments	3
Previous Studies	3
Material	4
Testing Procedure	4
Content	4
Results	6
Test Gain	6
Mastery Set Gain	7
Conclusion	9
Appendix	9
Test Data	9
Mastery Data	13
Skill Documentation - Simple Probability	17
Skill Documentation - Combinations	21
Skill Documentation - Permutations	23
Skill Documentation - Compound Probability	25
Problem Set Printout - Probability	28
Skill Documentation - Finding Parallel Equations	75
Problem Set Printout - Finding Parallel Equations	77
Skill Documentation - Finding Perpendicular Equations	83
Problem Set Printout - Finding Perpendicular Equations	85
Skill Documentation - Writing Linear Equations from Ordered Pairs	95
Problem Set Printout - Writing Linear Equations from Ordered Pairs	97
Skill Documentation - Writing Linear Equations from Slope and Ordered Pair	111
Problem Set Printout - Writing Linear Equations from Slope and Ordered Pair	112
Skill Documentation - Solving Systems of Equations	116
Problem Set Printout - Solving Systems of Equations	123
Skill Documentation - Solving Systems of Equations Story Problems	134
Problem Set Printout - Solving Systems of Equations Story Problems	138

## Abstract

ASSISTments is a web-based tutoring program covering 4<sup>th</sup> to 10<sup>th</sup> grade mathematics, where students are given a problems and may request hints to guide them through the problem if they feel they need help. Previous studies have shown the effectiveness of ASSISTments in improving student learning. In this study, we analyze whether the hints improve student learning significantly over just immediate correctness feedback. We found that while both methods of feedback improved student learning, neither one improved learning significantly better than the other. Especially when given easier problems, students were able to complete the problem sets in less time with answer-only feedback. For more difficult subjects, students were able to complete more problem sets using hints; however, they still tended to take longer on the problem sets they did complete. Because the hints caused the students to take more time to finish the problem sets and did not significantly improve student test scores, answer-only feedback may be more useful than hints.

## Background

### Description of ASSISTments

ASSISTments is an online tutoring system, covering a variety of mathematical subjects, including topics covered in 4<sup>th</sup> to 10<sup>th</sup> grade mathematics. Available content is currently being developed and updated to include more topics. The program combines assistance, typically consisting of tutoring, with assessment, reporting student results to teachers. In the program, students complete problem sets to attain “mastery” of the topic after meeting a specified goal, which is often to answer several problems correctly in a row. In each problem set, the students attempt to solve several problems based on a single skill. At any time, the student may request tutoring to help them understand the material and assist them in solving the problem.

The program performs many types of data and statistical analysis on student results, providing teachers with a variety of information on each student. The teachers can then use this information to adjust their teaching schedule and speed to better suit the needs of their class. The program also tracks each student’s strengths and weaknesses, as well as their progress on assigned material.

Most of the problem sets used in the study followed the Mastery Problem Set format, in which the students were required to correctly answer several problems in a row in order to complete the set. Thus, students were given related variablized problems until they mastered the content, completing the assignment. Students were not allowed to attempt more than a set number of problems in a given day, and in many cases were considered to have mastered the material if the student correctly answered the first problem.

### Previous Studies

In a previous study by Leena Razzaq and Neil Heffernan entitled “To Tutor or Not to Tutor: That is the Question”, the effectiveness of tutored problem solving (TPS) to presenting solutions was compared

(Razzaq & Heffernan, 2009). The tutored problem solving consisted of making students work through problems step by step, while the solutions method showed the student the entire solution for them to read and understand. The study concluded that there was significant learning regardless of the tutoring method, and students did significantly more problems with solutions compared to TPS. The study also found that more proficient students benefited more from seeing solutions than from tutored problem solving, while less proficient students benefited slightly more from tutored problem solving.

## **Material**

### **Testing Procedure**

The students were assigned to two groups and given new subject material each week. On the first day of the new week, the students were given a pre-test with questions representative of the material they would be studying over the course of the week. This allowed the establishment of prior knowledge; as the primary concern was with learning gains, it was necessary to account for knowledge the students had before working with the ASSISTments tutoring. During the week, students were asked to complete several Mastery problem sets designed to provide practice with the week's content. Students in one group were given problem sets with the traditional ASSISTments tutoring, while students in the other group received only the answer if they asked for a hint. On the last day of the week, the students were asked to complete a post-test with questions similar to the pre-test to determine whether they had improved since the pre-test. The post-test for one week was typically taken the same day as the pre-test for the following week. Each week, the groups switched roles: the group that had been receiving tutoring instead received answers-only feedback, while the group that had been receiving answers was given tutoring. The pre- and post-tests were given in a testing environment controlled by a teacher to prevent cheating, but the students were allowed to work on the problem sets at any time during the week.

We examined the effect of hints and answer feedback on the Mastery Problem Sets the students were assigned each week. We used pre-test scores to divide the students into high-, mid-, and low-level groups. Those who on average scored one standard deviation above the mean pretest score were considered high-level; those below one standard deviation were considered low-level. We also examined separately students who relied more heavily on the hints; those who were in the 75th percentile for total number of hints used were considered to have used more hints.

### **Content**

For each week, we needed to create a pre- and post-test as well as problem sets for each skill within that week (Table 1). For each problem set, it was necessary to create one version with hints, and one version with answers only. The content used for this study consisted of both previously developed content and new content developed by our IQP group. Much of the content we developed was designed to teach material included in the Pembroke Academy Competency Exams, which attending students are required to pass to graduate. These exams were provided by Allan Clarke. The students were able to complete only eight weeks of material during our study.

Week	Content	Author
1	Decimals and Fractions	Christopher Kevorkian
2	Percents and Proportions	Christopher Kevorkian
3	Absolute Value and Order of Operations	Dan Moyer
4	Scatter, Stem and Leaf, and Box and Whisker Plots	Peter Costello
5	Probability Part 1	Peter Costello
6	Probability Part 2	Peter Costello
7	Slope and Equations of Lines Part 1	Christopher Kevorkian
8	Slope and Equations of Lines Part 2	Christopher Kevorkian
9	Systems of Equations	Dan Moyer
10	Systems of Equations Story Problems	Dan Moyer
11	Exponents	Peter Costello
12	Factoring Polynomials	Dan Moyer

Table 1 - Content Summary

Previously developed content, as well as new content was designed to teach material for the probability material presented in Competency Quiz One. The previously developed content on simple probability and compound probability was reviewed and updated, to match the format of the new probability problems. Two methods of solving probability problems were introduced. For simple probability, the tutoring asked students to analyze the problem logically and presented students with the basic concepts of probability. For more advanced probability problems, such as compound probability and permutations, the tutoring emphasized the use of formulas to solve problems. Several variablized templates were created to cover topics including: simple probability, compound probability, permutations, and combinations.

Previously developed content for scatter plots, stem and leaf plots, and box and whisker plots was combined to provide additional content for the study. One problem set for each of these topics was made.

New content was designed to teach the material presented in Competency Quizzes four and five. These quizzes covered linear systems of equations involving two variables. Students were asked to solve systems of equations graphically and numerically by substitution and linear combination methods. Variablized templates were designed for each of these solution methods. Students were also asked to solve story problems involving linear systems of equations of two variables. Topics on the quiz included problems about mixtures, speeds, money, digits of a number, and ages. One Variablized template was created for each of these subjects, as well as several other templates to introduce the students to basic systems of equations story problems.

Previously developed content for absolute value and order of operations was combined to provide additional content for the study. One problem set for each topic was assembled, as well as a problem set combining both topics.

Previously developed content for decimals and fractions was combined to provide additional content for the study. This covered subtracting decimals, adding fractions, dividing decimals, dividing fractions, and multiplying fractions. Problem sets were made for each of these topics.

Previously developed content for percents and proportions was combined to provide additional content for the study. This covered percent and proportion word problems and conversions between percents, proportions, and decimals.

Previously developed content for mean, median, mode, and range was combined to provide additional content for the study. Problem sets were made for each topic, plus an additional problem set containing a mixture of the different categories.

New content was designed to teach the material presented in Competency Quiz three. This quiz covered slope and equations of lines for linear equations. Skills in this quiz required students to find slopes when given two ordered pairs and write linear equations when given either ordered pairs or the slope and an ordered pair. Skills also included finding the equation for lines perpendicular or parallel to a given line. For each skill, several variablized templates were created and problem sets were built from these templates.

## Results

### Test Gain

One of our primary objectives was to determine what the effect of the answers problem sets was compared to the effect of the hints problem sets in terms of the students' overall gain. Overall gain for a week was determined by comparing a student's score on post-test with his or her score on the corresponding pre-test. Both the pre- and post-tests contained the same number of problems, so the overall gain is simple the difference of the pre- and post-test. If this value was positive, it indicated that the student likely increased their understanding of the subject they were given that week.

Before comparing the effects of answers vs. hints, our goal was to determine if the Mastery Problem Sets the students were given caused improvement in gain scores regardless of whether or not they received tutoring. To do this, we looked at the average pre-test scores and average post-test scores of each student across all weeks of the study. We performed a paired t-test on these two sets of data, which resulted in a p-value of 9.61818E-26. This meant that the higher average of post-test scores was statistically significant, and therefore we concluded that the Mastery Problem Sets were successfully increasing students' understanding of the material they were studying.

Average Pre-Test Score	Average Post-Test Score	P-Value
41.03%	58.72%	9.61818E-26

Table 2 - Average Test Scores

We determined if there was a difference in gain scores when a student received tutoring with hints compared to when that same student received the answer only tutoring. We performed a paired t-test comparing the average gain score from the weeks a student received hints to the average gain score from the weeks that student received answers, and this produced a p-value of 0.12444. Since this test was non-conclusive, we duplicated this same test a number of additional times, each time looking at a different subset of the students. Our goal was to see if we could find a particular type of student that benefited more from hints or answers Mastery Problem Sets.

Category	Average Hint Gain	Average Answer-Only Gain	P-Value
All Students	0.695238095	0.528846154	0.124440146
High-Level	0.519230769	0.410714286	0.80865532
Medium-Level	0.715827338	0.52962963	0.249501644
Low-Level	0.733333333	0.6	0.300093247
Finishers	0.938596491	0.705357143	0.268071493
Used More Hints	0.754385965	0.644067797	0.760925774

Table 3 - Average Hint Gain

For the high-, medium-, and low-level students, as well as for finishers and those who used more hints, we performed paired t-tests using the same method as is described above. Although the average hint gain was somewhat higher than the average answer-only gain in each subset of students, the p-values were never low enough to conclude that the gains were significantly different. The high p-values only served to confirm that regardless of whether hints or answers were provided, students were achieving positive gain scores, but we could not conclusively say that there was a difference in gain scores between hints and answers-only Mastery Problem Sets.

### Mastery Set Gain

We found that students were more likely to master problem sets when they were given hints. A paired t-test was used to show a statistically significant difference in the percentage of problems mastered for each condition, with a p-value of 0.00043 (Mastery Data Appendix) . On average, students with hints mastered nearly six percent more of the problem sets than those given only answers, an effect size of 0.347. Excluding the mid- and low-level students resulted in a p-value of 0.79; there was no significant



difference in problem sets mastered between hints and answers for the high-level students. We also found a statistically significant correlation between hint use and the number of problem sets mastered. Students who used more hints mastered eight percent fewer mastery problem sets than those who used fewer. This is likely because students who were less familiar with the material had difficulty mastering the problem sets and needed more hints, a significant selection bias.

We found that students are able to master the assigned problem sets in fewer attempts when they are given hints. A paired t-test was used to measure the difference in number of attempts students used to master problem sets when given hints compared to when they were given answers. The difference was statistically significant with a p-value of 1.66E-11; on average, students given hints were able to master the problem sets in 3.8 fewer attempts than those given answers, an effect size of 0.738 (Mastery Data Appendix). This result was consistent for all levels of student, as well as those who mastered all the problem sets involved in the study and those who frequently used hints.

We found that students are able to master the problem sets more quickly when given answers. The p-value obtained from a paired t-test comparing students' total time working on the mastery problem sets produced a statistically significant p-value of 0.00001 and an effect size of 0.507 (Mastery Data Appendix). While high-level students did not take significantly longer to do either the hints or answers problem sets, mid- and low-level students were able to master the problem sets significantly more quickly with answers. This result was strongly correlated with those students who frequently used hints, though this may be the result of selection bias: low-level students were more likely to use hints.

Table 4 summarizes the p-values from each t-test we performed. P-values below .05 were considered to be statistically significant.

Table of P-Values	Difference in Number Mastered	Difference in Attempts to Master	Difference in Time to Master
All	0.000426868	1.66361E-11	1.03336E-05
High	0.794112372	0.012729567	0.223137604
Medium	0.001382721	8.01121E-10	0.000173766
Low	0.063726132	0.01307487	0.021750731
Finished All	N/A	4.34738E-07	0.067856648
Used Hints	0.058437618	0.000302128	0.048984305
Hints Difference	0.025716974	5.89514E-06	0.005881061

Table 4 - Mastery Set P-Values

Figure 1 illustrates the results of hint and answer feedback. Given hints, students were able to master more problem sets with an average of fewer attempts. However, students (especially mid- and low-level students) were able to master the problems sets in significantly less time when given answers. Furthermore, the difference in the number of problem sets the students mastered does not seem to have affected performance on the post-test. As the students appeared to learn an equal amount under both conditions but were able to learn more quickly with answers, answer-only feedback may prove superior to hints in mastery learning.

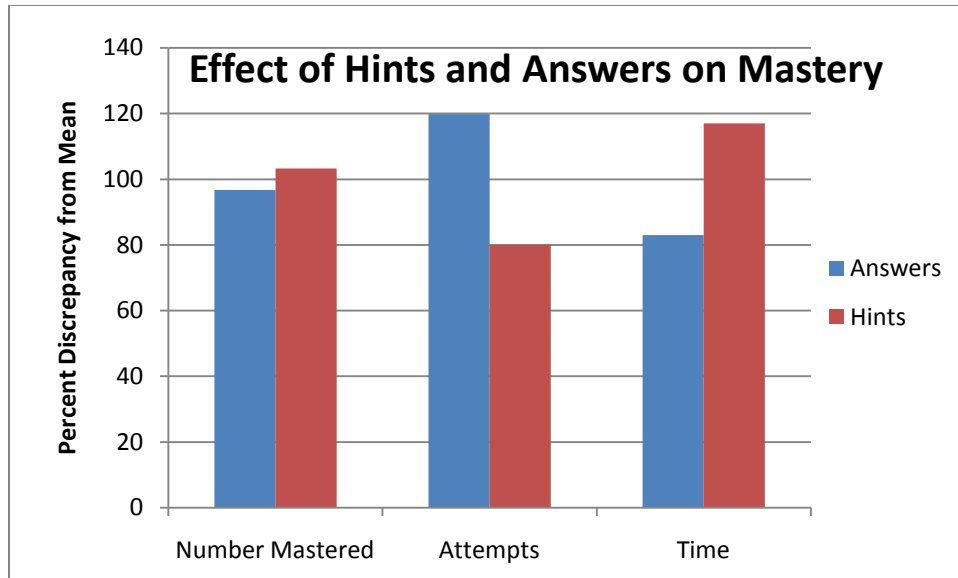

Figure 1 - Relative Effectiveness of Tutoring Methods

As the number of problem sets the students mastered was not controlled, we are unable to prove causation between the number of problem sets the students mastered and their performance on the post-test. It seems possible that both mastery performance and post-test performance are caused by students' prior knowledge of the subject, skill level, and motivation.

## Conclusion

We found that students of all levels were able to significantly improve their test scores using the ASSISTments program. The students learned when given either hints or answers feedback, and there was no significant difference between the two conditions in test score improvement. While students who were given hints were able to master more problem sets in fewer attempts, those given answers were able to master the problem sets more quickly. The difference in the number of problem sets the students mastered in each condition does not appear to have affected their post-test results. Instead, attempting the problem more times with answers seems to have allowed the students to learn the material just as well in less time. Additional studies should be performed to determine whether there is a significant difference in knowledge retained after a longer period of time, as our study focused only on learning over the course of a single week.

## Appendix

### Test Data

	Answers			Hints		
ID	Mean Pre-Test	Mean Post-Test	Gain	Mean Pre-Test	Mean Post-Test	Gain
78073	0.625	0.875	1	0.325	0.7125	1.25

78903	0.525	0.6375	0.5	0.541666667	1	1.5
78904	0.2125	0.625	1.25	0.75	1	1
78905	0.875	1	0.5	0.5125	0.6375	0.5
78906	0.625	1	1.5	0.5125	0.6375	0.75
78907	0.8125	0.75	-0.5	1	1	0
78908	0.3375	0.35	-0.25	0.75	0.541666667	-0.5
78909	0.5625	0.75	0.75	0.833333333	1	0.5
78910	0.575	0.7125	0.5	0.875	1	0.5
78911	0.3875	0.8875	1.75	0.708333333	1	1
78912	0.875	0.833333333	0	0.4375	0.9375	1.75
78913	1	1	0	0.45	0.375	-0.25
78915	0.5125	0.3	-1	0.708333333	1	1
78916	0.325	0.75	1.5	1	1	0
78917	0.4	0.7625	1.25	0.708333333	1	1
78918	0.458333333	0.666666667	1	0.3875	0.7	1
78919	0.2625	0.4	0	0.458333333	0.583333333	0.5
78920	0.833333333	1	0.5	0.7625	0.825	0.25
78921	0.35	0.9375	2.25	1	1	0
78922	0.75	0.875	0.5	0.5125	0.625	0.5
78923	0.875	1	0.5	0.4375	0.525	0
78926	0.583333333	1	1.5	0.5125	0.8125	1
78970	0.416666667	0.875	1.5	0.4625	0.2	-0.75
78971	0	0	0	0.25	0	-1.25
78972	0.875	1	0.5	0.375	0.5	0.25
78974	0.375	0.5625	0.5	0.833333333	0.875	0
78976	0.583333333	1	1.5	0.2	0.325	0.25
78977	0.1125	0.375	1	0.291666667	0.875	2
78978	0.625	0.833333333	1	0.2	0.575	1
78980	0.583333333	1	1.5	0.325	0.5625	0.75
78981	0.25	0.875	2	0.5	0.2	-0.75
78982	0.05	0.15	0.5	0.333333333	1	2.5
78983	0.4	0.5625	0.5	0.625	1	1.5
78984	0.5625	0.6375	0	0.708333333	1	1
78985	0.541666667	0.708333333	0.5	0.375	0.4875	0
78986	0	0	0	0.25	0.15	-0.5
78987	0.45	0.275	-0.5	0.416666667	0.416666667	0
78988	0.5	0.6375	0.25	0.708333333	1	1
78989	0.375	0.4	-0.25	0.458333333	1	2
78990	0	0.333333333	1	0.3125	0.5	0.25
78991	0.5625	0.375	-0.5	0.583333333	1	1.5
78992	0.333333333	1	2.5	0.225	0.625	1.5

79012	0.458333333	0.625	0.5	0.4625	0.5875	0.5
79013	0.583333333	1	1.5	0.3875	0.3375	-0.25
79014	0.708333333	0.875	0.5	0.325	0.45	0.5
79015	0.275	0.2	0	0	0.625	2
79016	0.5625	0.5	-0.25	0.833333333	0.833333333	0
79017	0.25	0.1	-0.75	0	0.333333333	1
79018	0.375	0.45	0	0.625	1	1.5
79019	0.45	0.375	-0.25	0.291666667	0.541666667	1
79020	0.5	0.45	-0.25	0.875	0.875	0
79021	0.225	0.325	0.5	0.875	0.166666667	-2.5
79022	0.45	0.4	-0.25	0.583333333	0.833333333	1
79023	0.708333333	1	1	0.45	0.45	0.25
79024	0.166666667	0.291666667	0.5	0.4	0.325	0
79026	1	1	0	0.45	0.375	0
79027	0.583333333	0.583333333	0	0.275	0.325	0.25
79029	0.35	0.5625	1	0.333333333	0.458333333	0.5
79030	0.25	0	-1.25	0	0.333333333	1
79031	0.325	0.35	-0.25	0.75	1	1
79032	0	0.333333333	1	0.2125	0.05	-0.75
79033	0.75	0.708333333	0	0.2625	0.5875	0.75
79034	0.1	0.3	0.5	0.833333333	1	0.5
79054	0.25	0.525	0.5	0.75	1	1
79055	1	1	0	0.45	0.875	1.75
79056	0.875	1	0.5	0.5625	0.7	0.5
79057	0.575	0.75	0.75	1	1	0
79058	0.5625	0.825	1	0.833333333	0.833333333	0
79059	0.875	1	0.5	0.3375	0.8875	2
79060	0.833333333	0.875	0	0.225	0.625	1.5
79061	1	0.833333333	-0.5	0.325	0.875	1.75
79062	0.875	0.833333333	0	0.45	0.6375	1
79063	0.75	1	1	0.35	0.625	1.5
79064	0.666666667	1	1	0.3875	0.8125	1.5
79066	0.4375	0.6375	0.75	0.875	1	0.5
79067	0.75	0.5	-1	0.5	0.7	0.75
79068	0.325	0.625	0.75	0.875	1	0.5
79069	1	1	0	0.3375	0.7625	1.5
79070	0.75	1	1	0.525	0.95	1.75
79071	0.833333333	0.833333333	0	0.4375	0.6375	0.5
79073	0.575	0.875	1.25	1	1	0
79074	0.5125	0.7625	1	0.875	1	0.5
79075	0.45	0.6375	0.5	0.833333333	1	0.5

79217	0.875	1	0.5	0.575	0.75	1
79264	0.541666667	0.708333333	0.5	0	0.225	0.75
79547	0.45	0.35	-0.5	0.333333333	0.583333333	1
79585	0.483333333	0.316666667	-0.25	0.125	0.333333333	0.75
81446	0.658333333	0.679166667	0	0.354166667	0.9375	2
81457	0	0.145833333	0.5	0.4	0.5625	0.5
81458	0.65	0.629166667	0.25	0.354166667	0.625	1
81464	0.15	0.391666667	0.5	0.083333333	0.583333333	1.75
81470	0.35	0.495833333	0.5	0.083333333	0.458333333	1.25
81648	0.45	0.470833333	0.5	0.1875	0.354166667	0.5
81773	0.4375	0.625	0.75	0.545833333	0.566666667	0
85685	0.516666667	0.433333333	-0.5	0.083333333	0.375	1
85686	0.375	0.2125	-0.5	0.125	0.125	0
85687	0.229166667	0.4375	0.75	0.175	0.825	2.25
85689	0.183333333	0.416666667	0.25	0.083333333	0.375	1
85690	0.583333333	0.458333333	-0.25	0.441666667	0.616666667	0.75
85691	0.245833333	0.458333333	1	0.083333333	0.416666667	1.25
85692	0.083333333	0.229166667	0.5	0.1	0.15	0.25
85693	0.25	0.541666667	1.25	0.358333333	0.75	1.25
85694	0.0625	0.708333333	2.25	0.1	0.670833333	1.75
85696	0.333333333	0.520833333	0.5	0.7625	0.666666667	-0.25
85697	0.233333333	0.770833333	1.75	0.208333333	0.375	0.5
85698	0.420833333	0.666666667	0.75	0.229166667	0.291666667	0.25
85699	0.229166667	0.8125	2	0.616666667	0.616666667	0
85701	0.354166667	0.520833333	0.5	0.5875	0.5875	0
85714	0.533333333	0.8875	1.25	0.375	0.479166667	0.5
85715	0.595833333	0.720833333	0.5	0.333333333	0.583333333	0.75
85716	0.316666667	0.616666667	0.75	0.375	0.5	0.5
85717	0.516666667	0.658333333	0.75	0.229166667	0.541666667	1.25
85718	0.1875	0.125	-0.25	0.275	0.2	0
85719	0.208333333	0.5625	1.25	0.566666667	0.770833333	1
85720	0.4	0.691666667	0.75	0.270833333	0.604166667	1.25
85721	0.125	0.583333333	1.75	0.408333333	0.6375	0.5
85722	0.083333333	0.3125	0.75	0.275	0.595833333	1
85723	0	0	0	0	0	0
85724	0.366666667	0.325	-0.25	0.166666667	0.5	1.25
85725	0.166666667	0.5625	1.5	0.133333333	0.308333333	0.5
85726	0.358333333	0.804166667	1.5	0.083333333	0.5625	1.75
85727	0.354166667	0.5625	0.75	0.545833333	0.679166667	0.5
85728	0	0.354166667	1.25	0.2	0.275	0
85729	0.208333333	0.1875	0	0.416666667	0.916666667	1.5

85730	0.270833333	0.479166667	0.75	0.608333333	0.595833333	0.25
86045	0.291666667	0.5625	1	0.25	0.679166667	1.75
<b>Total</b>	<b>0.416426282</b>	<b>0.574158654</b>	<b>0.528846154</b>	<b>0.404246032</b>	<b>0.600079</b>	<b>0.695238</b>

## Mastery Data

ID	Average of Mastered		Average of Total Attempts		Sum of Total Time	
	Answers	Hints	Answers	Hints	Answers	Hints
78073	1	1	8	7.538461538	1063.84	5548.97
78903	1	1	7.181818182	4.285714286	3755.9	4575.53
78904	1	1	5.5	4.428571429	1449.49	2241.28
78905	1	0.962962963	8.142857143	10.92592593	1993.35	12352.31
78906	1	1	6.142857143	6.333333333	1137.46	6587.48
78907	1	1	7.411764706	4.411764706	2438.78	1537.69
78908	0.647058824	1	11.23529412	7.235294118	5146.16	4812.68
78909	1	1	10.52941176	3.882352941	4511.51	1437.18
78910	1	1	8.882352941	4.941176471	5626.42	3739.41
78911	0.9375	1	7.0625	4.588235294	3187.88	2278.64
78912	1	1	6.857142857	5.333333333	913.98	5416.88
78913	1	0.904761905	6.428571429	5.19047619	3953.54	6458.69
78915	0.916666667	1	9.166666667	7.066666667	5646.68	3974.74
78916	1	1	8.705882353	7.647058824	4874.17	2202.15
78917	1	1	15.94117647	5.294117647	5051.26	2560.25
78918	0.857142857	1	13.28571429	6.111111111	1993.3	5089.26
78919	0.923076923	1	7.692307692	4.875	2457.2	2561.09
78920	1	1	7	4.851851852	1064.63	3334.88
78921	1	1	10.29411765	4.294117647	7254.52	3660.4
78922	1	0.961538462	7.142857143	7	903.86	5863.43
78923	1	0.95	8.714285714	5.25	1204.11	5249.8
78926	1	1	6	6.115384615	1389.25	7051.99
78970	0.857142857	0.916666667	27	8.375	3369.5	7130.37
78971	0	0.888888889	11	7.777777778	434.91	2894.3
78972	0.857142857	0.941176471	12.71428571	5.176470588	1824.58	2863.91
78974	0.875	1	11.4375	6.6875	5849.28	3600.51
78976	0.833333333	0.941176471	16.16666667	13.35294118	4849.69	8146.12
78977	0.9	0.875	9.7	11.5625	4176.16	6347.37
78978	1	0.961538462	11.14285714	9.923076923	1199.49	7378.6
78980	1	0.92	14.14285714	10.28	1942.62	8758.87
78981	0	1	14.66666667	4.647058824	669.28	3032.62
78982	1	1	14.88235294	5.0625	7296.52	3022.22
78983	0.866666667	1	8.133333333	5.1875	5812.55	3260.8

78984	0.9375	1	12	5.4375	6159.18	2411.45
78985	1	0.916666667	11.14285714	7.583333333	799.58	5223.5
78986	0	0.666666667	3.5	7.666666667	335.93	1980.35
78987	0.8	1	8.3	11.9375	3116.35	7160.17
78988	1	1	10.13333333	5.6875	4126.9	2758.6
78989	0.923076923	1	13.61538462	10.6875	4542.92	5915.17
78990	1	1	14.14285714	7.684210526	4030.13	7016.39
78991	0.888888889	0.875	10.88888889	8.125	3859.98	5537.62
78992	1	1	16.14285714	8.807692308	2730.02	14141.94
79012	1	0.954545455	10	6.636363636	1900.56	4687.74
79013	1	0.952380952	11.42857143	8.333333333	1740.74	5326.71
79014	0.857142857	0.95	10.57142857	5.95	1297.86	4530.59
79015	0.333333333	0.866666667	7.333333333	6	798	3699.59
79016	1	1	6.625	11.75	1146.21	5415.04
79017	0.5	0.5	10.25	8.7	1410.89	3900.83
79018	0.8125	1	22.0625	4.3125	5828.13	1891.41
79019	0.692307692	1	9.615384615	15.125	1963.23	4025.15
79020	1	0.9375	11.11111111	10.875	2412.62	3215.94
79021	0.888888889	0.9375	13	10.0625	2325.16	5750.68
79022	1	1	14.58823529	7.9375	7580.28	3571.87
79023	1	1	10.42857143	7.5	1429.01	6492.25
79024	0.4	0.928571429	20.8	12.5	2747.44	5178.97
79026	1	1	7.428571429	5.411764706	1616.32	4560.54
79027	0.714285714	0.941176471	12.57142857	8.058823529	1942.24	4981.08
79029	0.888888889	1	8.888888889	9.75	1707.33	2885.88
79030	0	1	12	4.166666667	559.43	1786.81
79031	0.8125	1	11.75	6.5625	5133.78	4107.28
79032		0.8		10.2		3070.43
79033	1	1	9.571428571	6.192307692	1307.83	4616.43
79034	0.933333333	1	11.86666667	8.9375	3604.15	2715.39
79054	1	1	10.29411765	4.882352941	2791.39	1243.18
79055	1	1	6.857142857	9.777777778	963.88	5485.62
79056	1	1	6.857142857	5.592592593	710.22	2717.16
79057	0.882352941	1	6.882352941	4.5	2952.18	1301.48
79058	1	1	10.29411765	4.294117647	5904.88	1258.69
79059	1	1	7.857142857	8.296296296	851.17	5306.37
79060	1	0.863636364	12.42857143	9.090909091	1228.6	3978.96
79061	1	1	8	5.925925926	1120.03	5004.22
79062	1	1	12	8.444444444	1503.18	7782.02
79063	1	0.909090909	9.714285714	8.545454545	1331.46	5617.63
79064	0.857142857	1	11.42857143	6.925925926	1430.09	7296.3

79066	1	1	15.35294118	4.823529412	6175.35	1733.29
79067	0.857142857	1	8.285714286	4.866666667	1269.33	3915.94
79068	0.941176471	0.944444444	12.05882353	5.555555556	5708.69	3223.71
79069	1	1	10.28571429	7.555555556	2127.36	7510.63
79070	1	1	13	9.259259259	2534.73	6673.45
79071	1	0.958333333	5.857142857	6.333333333	952.45	5867.09
79073	1	1	9.764705882	3.882352941	3984.34	2638.17
79074	0.933333333	1	10.06666667	4.1875	2705.87	1976.07
79075	1	1	9	6.4375	6648.51	1852.05
79217	1	1	6.142857143	5.740740741	1007.34	5242.9
79264	0.833333333	0.857142857	13.33333333	4.857142857	1070.6	3749.84
79547	0.846153846	0.923076923	8.769230769	13.92307692	2482.26	2903.96
79585	0.6	0.75	9.1	5.75	2840.08	2117.27
81446	1	0.875	14.78571429	14.75	7642.36	13870.64
81457	0	0.636363636	12	7.363636364	2800.18	3364.65
81458	0.5	0.8	15	6.2	2864.55	1186.59
81464	0.727272727	0.5	8	3.5	4866.57	1942.48
81470	0.857142857	0.666666667	9.857142857	14.8	4848.9	6352.78
81648	1	0.8125	7.545454545	5.0625	2911.13	2972.8
81773	0.727272727	0.857142857	10.45454545	4	3883.33	2672.38
85685	0.833333333	0.75	12.83333333	10.5	4999.03	8618.23
85686	0.833333333	0.777777778	9.583333333	10.55555556	2981.33	2749.66
85687	0.555555556	0.727272727	9.555555556	10.72727273	3753.72	5488.65
85689	0.666666667	0.2	8	5.2	593.16	4539.54
85690	0.833333333	0.875	4.166666667	2.75	1433.78	1569.89
85691	0.857142857	0.692307692	31.85714286	19.46153846	7442.57	8441.96
85692	0.6	1	23.6	10.8	2156.59	1409.5
85693	1	1	12.69230769	8.357142857	5865.24	6342.28
85694	0.846153846	1	17.15384615	15.35714286	8750.3	8538.59
85696	0.8	0.928571429	12.5	5.357142857	3225.27	3150.32
85697	0.636363636	0.363636364	9.636363636	6	4610.64	3932.65
85698	0.928571429	0.8	19.92857143	18.6	6531.42	7376.38
85699	0.636363636	0.928571429	11.90909091	8.428571429	4201.1	3361.44
85701	0.5	0.692307692	6.5	5.615384615	2399.87	2723.77
85714	0.714285714	0.636363636	17.78571429	7.272727273	7722.19	2850.18
85715	0.928571429	0.769230769	13.21428571	13	5499.62	9274.87
85716	0.857142857	0.7	15.21428571	10.9	4816.31	3799.93
85717	0.928571429	0.8	9.285714286	23.2	5729.27	8126.84
85718		0.8		9.6		1374.97
85719	1	1	13.30769231	4.714285714	5486.11	2770.92
85720	0.785714286	0.727272727	19	16.18181818	7329.89	6708.11



85721	0.9	0.857142857	11.3	10.5	3431.47	4902.93
85722	0.666666667	0.8	2.333333333	3.5	164.89	1353.34
85723		0.8		2.4		675.4
85724	0.428571429	0.75	9.714285714	8.625	2919.64	1621.39
85725	0.166666667	0.666666667	5.833333333	9.833333333	884.68	2959.74
85726	0.692307692	0.5	14.38461538	8.3	5662.8	5608.39
85727	0.692307692	1	20.84615385	11.57142857	6585.36	5405.07
85728	0.666666667	0.714285714	39.33333333	6.285714286	262.19	1143.15
85729	0.375	1	12.625	4.3	1662	1300.82
85730	0.846153846	0.785714286	12.61538462	10.28571429	4992.9	3786.41
86045	0.428571429	0.6	6.857142857	11.7	1178.53	3706.74
<b>Total</b>	0.872186495	0.931101407	11.53054662	7.705967977	395977	557896.6

# Probability

Skill <b>Probability Simple</b>	Class <b>8<sup>th</sup> Grade</b>
------------------------------------	--------------------------------------

Mastery Problem Set #8662	Number of Templates 3
Number to Master 5	Number of Attempts 7

## Templates

29970 (can make 6)

- Number is randomized between 1 and 6

What is the probability of rolling a 3 with a six-sided number die?

[Comment on this question](#)

Show me hint 1 of 2

Type your answer below (mathematical expression):

Submit Answer

30247

**Of the 47 crates in the warehouse, 11 of them are heavy. If one crate is picked at random, what is the probability that the crate will be heavy?**

- Total number of objects randomized between 20 and 50
- Number of objects with given characteristic is randomized between 8 and 18
- Location randomized between: warehouse, class, and parking lot
- Special Characteristic randomized between: boys, girls, heavy, light, used, and new

30246

**A bag contains 7 red, 1 green, and 2 blue marbles. John is going to draw out a marble without looking in the bag.**

**What is the probability that he will draw either a green or a blue marble?**

- Numbers randomized between 1 and 10.
- Object randomized between: balls, marbles, and popsicles

59969 (can make 26)

**A card is selected at random from a standard deck of 52 cards. Find the probability of choosing a jack or a red card.**

**Enter your answer as a fraction**

- Jack is randomized between: 2,3,4,5,6,7,8,9,10,jack,queen,king, and ace
- Red is randomized between red and black

62441 (can make 52)

**A card is selected at random from a standard deck of 52 cards. Find the probability of choosing a spade or jack card.**

**Enter your answer as a fraction**

- Spade is randomized between: spade, diamond, heart, and club
- Jack is randomized between: 2,3,4,5,6,7,8,9,10,jack,queen,king, and ace

Tony has a cookie jar, that he likes to randomly select cookies from it to eat. The jar has 7 chocolate chip cookies, and 6 oatmeal raisin cookies. What is the probability that Tony gets a chocolate chip cookie from the jar?

(Enter your answer as a fraction)

[Comment on this question](#)

Show me hint 1 of 4

Type your answer below (mathematical expression):

Submit Answer

29971

- Numbers are randomized between 2 and 11

30002

**Tony has a marble jar that he likes to randomly select marbles from it to play with. The jar has 6 orange marbles, and 3 purple marbles. What is the probability that Tony gets an orange marble from the jar?**

- Numbers are randomized between 2 and 11
- Name of boy randomized between: Billy, Jeff, John, Tony, Steve, Chris, and Jason

## 30063

- Number of Chinese numbers randomized between: 2 and 11
- Number of Mexican numbers randomized between: 2 and 11
- Number of Italian numbers randomized between: 2 and 11
- Number of French numbers randomized between: 2 and 11

The table below shows the number of restaurants advertisement in a city directory. The telephone numbers of these restaurants are written on separate slips of paper and one is selected at random. What is the **probability** that the telephone number of an **Italian** restaurant is selected?

Type of Restaurant	Number
Chinese	11
Mexican	16
Italian	11
French	10

(Write your answer as a fraction, you can simplify if you want)

[Break this problem into steps](#)

Type your answer below (mathematical expression):

[Submit Answer](#)

# Probability

Skill <b>Combinations</b>	Class <b>8<sup>th</sup></b>
------------------------------	--------------------------------

Mastery Problem Set #9220	Number of Templates 1
Number to Master 5	Number of Attempts 7

## Templates

30449

- The number of hats is randomized between 2 and 8
- The number of pants is randomized between 2 and 6
- The number of shirts is randomized between 2 and 5

Danielle took her little cousin to the "Dress a Dragon" store where you dress the dragon in an outfit is made up of 1 hat, 1 pants, and 1 shirt.

There are 6 hats, 4 pants, and 3 shirts to choose from.

How many different combinations of outfits are there?

[Comment on this question](#)

Show me hint 1 of 2

Type your answer below (mathematical expression):

Submit Answer

57321 (can make 5)

**There are 7 kids in gym class. How many ways can a team of 4 be picked for a dodge ball team? (The order in which the kids are picked doesn't matter)**

- The number 4 is randomized between 2 and 6

# Probability

63593 (can make 7)

**There are 11 players on a basketball team. Only 5 players can be on the court at a time. How many different groups of 5 players can the team put on the court?**

- The number 11 is randomized between 8 and 14

This document is made by Peter Costello 2009

# Probability

Skill <b>Permutations</b>	Class <b>8<sup>th</sup></b>
------------------------------	--------------------------------

Mastery Problem Set <input type="text" value="#9218"/>	Number of Templates <input type="text" value="1"/>
Number to Master <input type="text" value="5"/>	Number of Attempts <input type="text" value="7"/>

## Templates

**31004 (can make 4)**

- Item is randomized between: vases, trolls, books, and cups

If there are 4 different vases on a shelf, how many different ways can they be arranged in a line?

[Comment on this question](#)

[Break this problem into steps](#)

Type your answer below (mathematical expression):

[Submit Answer](#)

**57737 (can make 3)**

**There are 3 different books on a shelf, how many different ways can they be arranged?**

- The number is randomized between 3 and 5



# Probability

59968 (can make 4)

**How many ways can three people be chosen for first, second, and third place from a group of 14 people?**

- The number 14 is randomized between: 12, 13, 14, 15

This document is made by Peter Costello 2009

# Probability

Skill	Class
<b>Compound Probability</b>	<b>8<sup>th</sup></b>

Mastery Problem Set #9222	Number of Templates 2
Number to Master 5	Number of Attempts 7

## Templates

58408

- Numbers are randomized between 1 and 8
- Asks for the chance of picking: green then red, red then blue, or blue then green

A bag of marbles contains 6 green, 4 red, and 4 blue ones. Find the probability of choosing a green marble, putting it back in the bag, and then picking a red marble. Leave your answer as a fraction

[Comment on this question](#)

Break this problem into steps

Type your answer below (mathematical expression):

Submit Answer

# Probability

29988

**When rolling a six-sided die, what is the probability of getting a 1 on the first roll, and a 3 on the second roll?**

- Numbers are randomized between 1 and 6

30448 (can make 4)

**Luis is going to toss 4 coins. What is the probability that he gets 4 heads in a row?**

- The number 4 is randomized between 3 and 6

30003

**Jeff has a marble jar that he likes to randomly draw marbles from it to play with. The jar has 7 orange marbles, and 10 purple marbles.**

**Today, Jeff wants to draw two marbles from the jar to play with. What is the probability that Jeff gets an orange marble on his first draw and a purple marble on his second draw?**

- The name is randomized between: Billy, Jeff, John, Tony, Steve, Chris, and Jason
- The numbers are randomized between 2 and 11

30004

**Jason has a cookie jar that he likes to randomly draw cookies from it to eat. The jar has 6 chocolate chip cookies, and 9 oatmeal raisin cookies.**

**Today, Jason wants to draw two cookies from the jar to eat. What is the probability that Jason gets a chocolate chip cookie on his first draw and an oatmeal raisin cookie on his second draw?**

- The name is randomized between: Billy, Jeff, John, Tony, Steve, Chris, and Jason
- The numbers are randomized between 2 and 11

# Probability

To win a game, Jane must get a sum of 12 on her next two spins of the arrow on the spinner shown below. All the sections of the spinner are of equal size. What is the probability that the results of Yepa's next two spins will have a sum of 12?

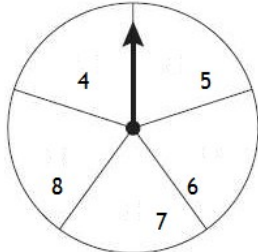

[Comment on this question](#)

[Break this problem into steps](#)

Type your answer below (mathematical expression):

[Submit Answer](#)

30419

- Numbers on the spinner are randomized:
  - The section with 4 is randomized between 1 and 5
  - The section with 5 is randomized between 2 and 6
  - The section with 6 is randomized between 3 and 7
  - The section with 7 is randomized between 4 and 8
  - The section with 8 is randomized between 5 and 9

58363

- Numbers on the spinner are randomized:
  - The section with 4 is randomized between 1 and 4
  - The section with 5 is randomized between 2 and 5
  - The section with 6 is randomized between 7 and 10
  - The section with 7 is randomized between 6 and 14
  - The section with 8 is randomized between 6 and 9

**Problem Set "Peter's Assistments"** id:[11026]**1) Assistment #62441 "62441 - Picking Cards from a Deck"**

A card is selected at random from a standard deck of 52 cards. Find the probability of choosing a  $\%v\{x\}$  or a  $\%v\{\text{color}\}$  card.

Enter your answer as a fraction

Algebra:

✓ 16/52

✗ 13/52

✗ 17/52

Hints:

- Remember what a deck of 52 cards looks like:

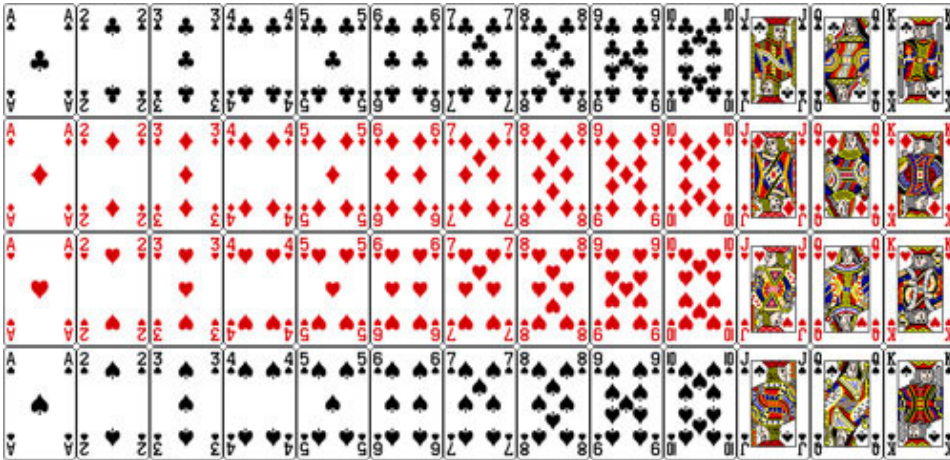

In a deck of cards, **half the cards are red** and half are black.

There are **four different suits: diamonds, clubs, hearts, and spades**.

There are **four of each of the number and face cards**.

- Therefore, of the 52 cards in the deck:

**13 will be  $\%v\{x\}$ s**

**4 will be  $\%v\{\text{color}\}$ s**

- Don't forget that **1 of the  $\%v\{\text{color}\}$ s is a  $\%v\{x\}$**

$$\text{Probability} = \frac{\text{Number of Desired Outcomes}}{\text{Number of Possible Outcomes}}$$

$$\text{Probability of choosing a } \%v\{x\} = \frac{13}{52}$$

$$\text{Probability of choosing a non } \%v\{x\} \%v\{\text{color}\} = \frac{3}{52}$$

In this case, the number of desired outcomes is  $13 + 3$  and the Number of possible outcomes is 52

$$13 + 3 = 16$$

$$\frac{13 + 3}{52} = \frac{16}{52}$$

$$\text{Probability of choosing a } \%v\{x\} \text{ or a } \%v\{\text{color}\} \text{ card} = \frac{16}{52}$$

$$\text{Enter : } \frac{16}{52}$$

## 2) Assistment #93189 "93189 - Picking Cards from a Deck"

A card is selected at random from a standard deck of 52 cards. Find the probability of choosing a heart or a queen card.

Enter your answer as a fraction

Algebra:

✓ 16/52

✗ 13/52

✗ 17/52

Hints:

- Remember what a deck of 52 cards looks like:

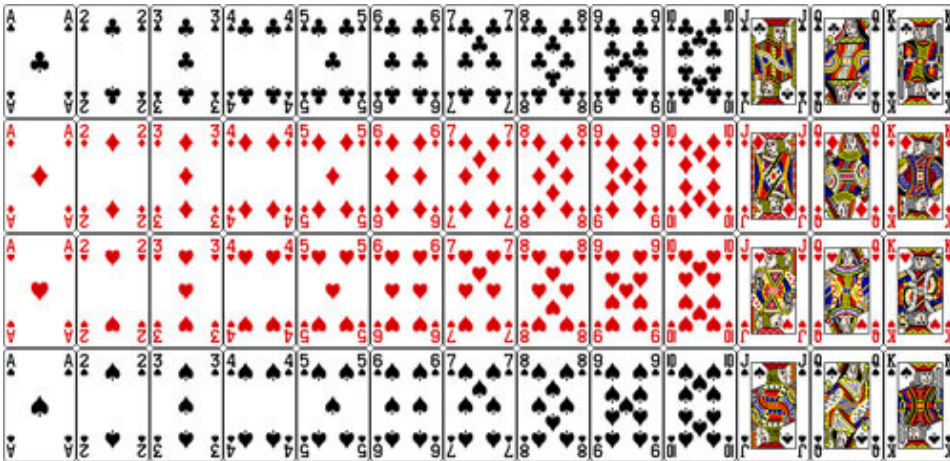

In a deck of cards, **half the cards are red** and half are black.

There are **four different suits: diamonds, clubs, hearts, and spades.**

There are **four of each of the number and face cards.**

- Therefore, of the 52 cards in the deck:

**13 will be hearts**

**4 will be queens**

- Don't forget that **1 of the queens is a heart**

$$\text{Probability} = \frac{\text{Number of Desired Outcomes}}{\text{Number of Possible Outcomes}}$$

$$\text{Probability of choosing a heart} = \frac{13}{52}$$

$$\text{Probability of choosing a nonheart queen} = \frac{3}{52}$$

In this case, the number of desired outcomes is  $13 + 3$  and the Number of possible outcomes is 52

$$\frac{13 + 3}{52} = \frac{16}{52}$$

$$\text{Probability of choosing a heart or a queen card} = \frac{16}{52}$$

$$\text{Enter : } \frac{16}{52}$$

### 3) Assistment #57321 "57321 - Pascals Triangle"

There are 7 kids in gym class. How many ways can a team of  $\%v\{x\}$  be picked for a dodge ball team? (The order in which the kids are picked doesn't matter)

**Fill in:**

✓  $\%v\{y\}$

**Scaffold:**

Let's try looking at a simpler problem:

There are 4 kids in gym class. How many ways can a team of 2 be chosen?

First you need to write out Pascal's Triangle to the 4th level.

Remember that in Pascal's Triangle, the next row is formed by adding the two numbers of the previous row, as shown below:

For use with probabilities, you can view Pascal's Triangle like this:

$$\begin{array}{cccccc}
 & & & & & 0C0 \\
 & & & & 1C0 & 1C1 \\
 & & 2C0 & 2C1 & 2C2 & \\
 & 3C0 & 3C1 & 3C2 & 3C3 & \\
 4C0 & 4C1 & 4C2 & 4C3 & 4C4 & 
 \end{array}$$

Each number corresponds to a certain  $nCr$  (combinations probability)

To find the number of combinations possible you need to look at the 2nd entry in the 4th row. (Remember the first row and the first entry in each row is numbered 0)

After forming Pascal's Triangle to the 4th row you make:

$$\begin{array}{l}
 1 \quad \text{Row: 0} \\
 1 \ 1 \quad \text{Row: 1} \\
 1 \ 2 \ 1 \quad \text{Row: 2} \\
 1 \ 3 \ 3 \ 1 \quad \text{Row: 3} \\
 1 \ 4 \ 6 \ 4 \ 1 \quad \text{Row: 4}
 \end{array}$$

Looking at the 2nd entry in the 4th column:

$$\begin{array}{l}
 1 \quad \text{Row: 0} \\
 1 \ 1 \quad \text{Row: 1} \\
 1 \ 2 \ 1 \quad \text{Row: 2} \\
 1 \ 3 \ 3 \ 1 \quad \text{Row: 3} \\
 1 \ 4 \ 6 \ 4 \ 1 \quad \text{Row: 4}
 \end{array}$$

The correct answer is 6.

**Multiple choice:**

I have read the problem and am ready to continue

**Hints:**

- First you need to write out Pascal's Triangle to the 4th level.



- Remember that in Pascal's Triangle, the next row is formed by adding the two numbers of the previous row:

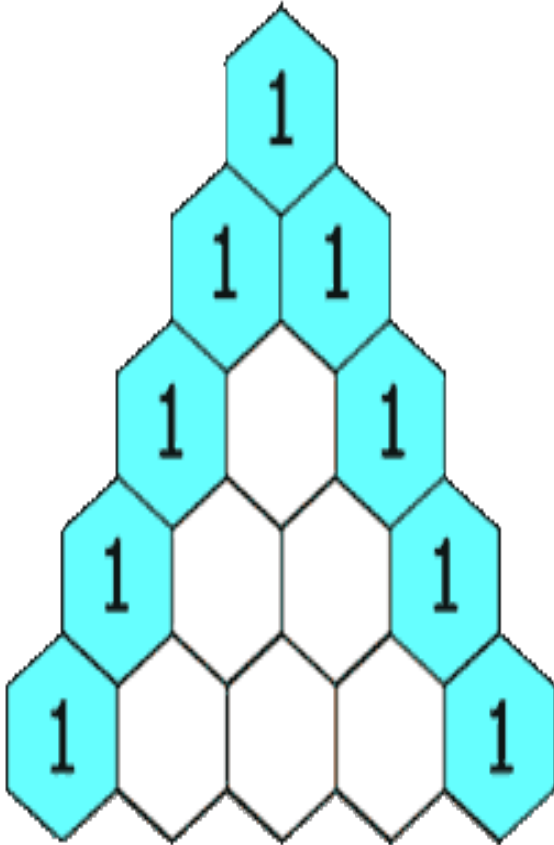

- To find the number of combinations possible you need to look at the 2nd entry in the 4th row. (Remember the first row and the first entry in each row is numbered 0)
- After forming Pascal's Triangle to the 4th row you make:
 

1					Row: 0
1	1				Row: 1
1	2	1			Row: 2
1	3	3	1		Row: 3
1	4	6	4	1	Row: 4
- Looking at the 2nd entry in the 4th column:
 

1	Row: 0
1 1	Row: 1
1 2 1	Row: 2
1 3 3 1	Row: 3
1 4 6 4 1	Row: 4

 The correct answer is 6, chose 6.

**Scaffold:**

Let's take a look at the original problem again:

There are 7 kids in gym class. How many ways can a team of  $\%v\{x\}$  for dodge ball be chosen from the class? (The order in which the kids are picked doesn't matter)

**Fill in:**

✓  $\%v\{y\}$

**Hints:**

- First draw pascal's triangle, then look for the  $\%v\{x1\}$  number in the 7th row.

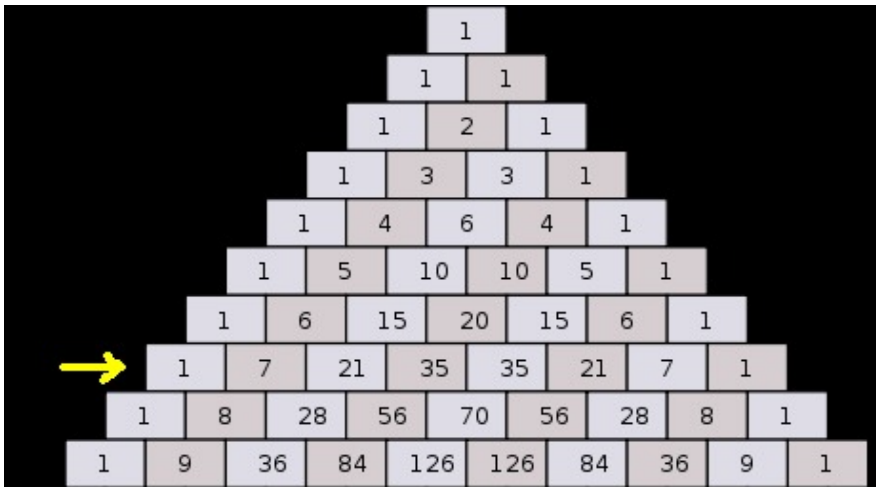

Looking to the  $\binom{x}{1}$  number in the 7th row, you can see that the answer is  $\binom{y}{1}$ .

Enter  $\binom{y}{1}$

#### 4) Assistent #93190 "93190 - 57321 - Pascals Triangle"

There are 7 kids in gym class. How many ways can a team of 4 be picked for a dodge ball team? (The order in which the kids are picked doesn't matter)

**Fill in:**

✓ 35

#### **Scaffold:**

Let's try looking at a simpler problem:

There are 4 kids in gym class. How many ways can a team of 2 be chosen?

First you need to write out Pascal's Triangle to the 4th level.

Remember that in Pascal's Triangle, the next row is formed by adding the two numbers of the previous row, as shown below:

For use with probabilities, you can view Pascal's Triangle like this:

$$\begin{array}{c} 0C0 \\ 1C0 \quad 1C1 \end{array}$$

	2C0	2C1	2C2	
3C0	3C1	3C2	3C3	
4C0	4C1	4C2	4C3	4C4

Each number corresponds to a certain NCR (combinations probability)

To find the number of combinations possible you need to look at the 2nd entry in the 4th row.  
(Remember the first row and the first entry in each row is numbered 0)

After forming Pascal's Triangle to the 4th row you make:

1	Row: 0
1 1	Row: 1
1 2 1	Row: 2
1 3 3 1	Row: 3
1 4 6 4 1	Row: 4

Looking at the 2nd entry in the 4th column:

1	Row: 0
1 1	Row: 1
1 2 1	Row: 2
1 3 3 1	Row: 3
1 4 6 4 1	Row: 4

The correct answer is 6.

**Multiple choice:**

I have read the problem and am ready to continue

**Hints:**

- First you need to write out Pascal's Triangle to the 4th level.

- Remember that in Pascal's Triangle, the next row is formed by adding the two numbers of the previous row:

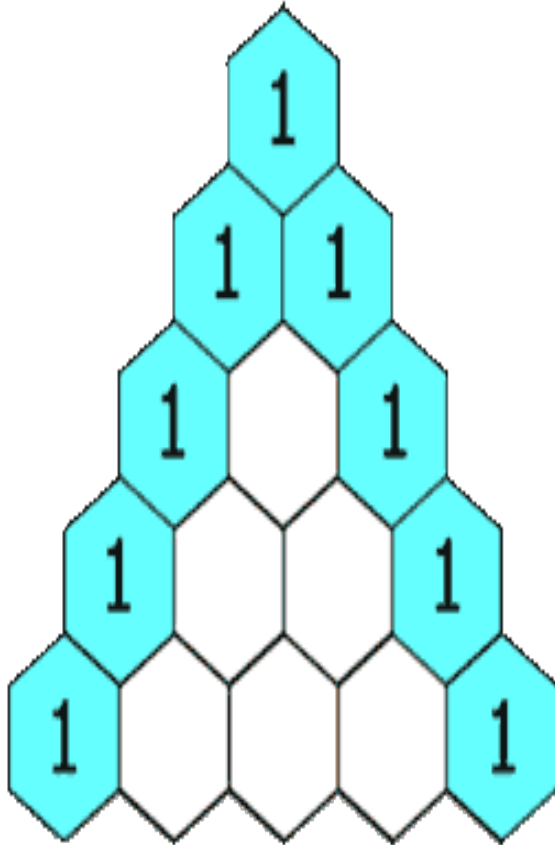

- To find the number of combinations possible you need to look at the 2nd entry in the 4th row. (Remember the first row and the first entry in each row is numbered 0)
- After forming Pascal's Triangle to the 4th row you make:
 

1					Row: 0
1	1				Row: 1
1	2	1			Row: 2
1	3	3	1		Row: 3
1	4	6	4	1	Row: 4

- Looking at the 2nd entry in the 4th column:

1 Row: 0  
 1 1 Row: 1  
 1 2 1 Row: 2  
 1 3 3 1 Row: 3

**1 4 6 4 1 Row: 4**

The correct answer is 6, chose 6.

#### Scaffold:

Let's take a look at the original problem again:

There are 7 kids in gym class. How many ways can a team of 4 for dodge ball be chosen from the class? (The order in which the kids are picked doesn't matter)

**Fill in:**

✓ 35

#### Hints:

- First draw pascal's triangle, then look for the 4th number in the 7th row.

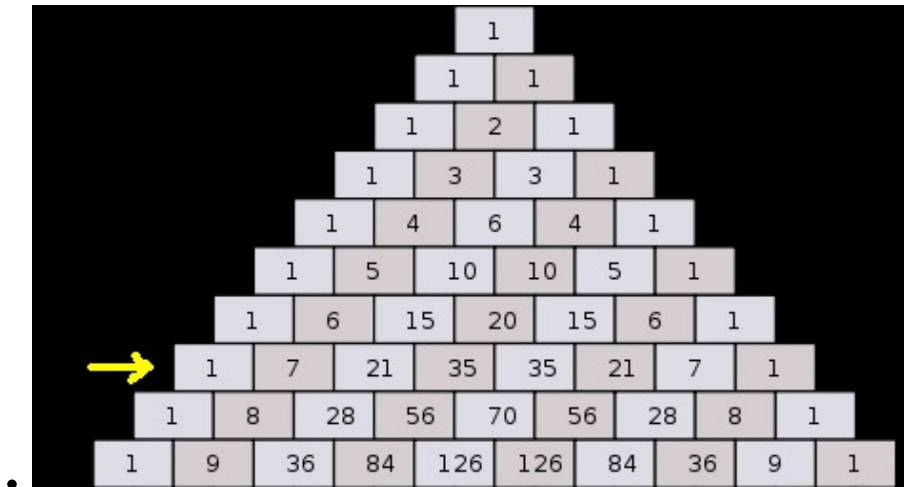



Looking to the **4th** number in the **7th** row, you can see that the answer is 35.

Enter 35

**5) Assistent #57734 "57734 - Reading Tree Diagrams"**

Based on the following tree diagram, what is the probability of picking a  $\%v\{x\}$  marble and then **not** a  $\%v\{y\}$  one?

**First Draw      Second Draw**

**Fill in:** %v{a} %v{c}**Hints:**

- The tree diagram **shows all the possible outcomes** that could occur.

The **first branch** shows all your **possible first picks**.

The **second branch** shows the **possible second picks**.

- For the first pick you want a **%v{x} marble**.

Follow the diagram to that colored box in the second column.

From this you know that the probability of the **first event** occurring is  $\frac{{\%v\{p1\}}}{4}$

- Next you want to **not** pick a  ${\%v\{y\}}$  marble.

Follow the diagram to the boxes that go first to a  ${\%v\{x\}}$  colored box and then **NOT** to  ${\%v\{y\}}$  colored boxes.

From this you know that the probability of the **second event** occurring is  $\frac{\%v\{p2\}}{4}$

Following the diagram:

There are  $\%v\{\mathbf{b}\}$  **desired outcomes** (the highlighted boxes in the last column).

While there are **16 possible outcomes** (total number of boxes in the last column).

$$\text{Probability} = \frac{\text{Number of desired outcomes}}{\text{Number of possible outcomes}}$$

$$\text{Chance of picking a } \%v\{x\} \text{ marble and then not a } \%v\{y\} \text{ marble} = \frac{\%v\{\mathbf{b}\}}{16}$$

Using the Multiplication Rule:

$$\text{Probability of the } \mathbf{first\ event} \text{ occurring} = \frac{\%v\{p1\}}{4}$$

$$\text{Probability of the } \mathbf{second\ event} \text{ occurring} = \frac{\%v\{p2\}}{4}$$

Multiplying the two probabilities:

$$\frac{\%v\{p1\}}{4} \times \frac{\%v\{p2\}}{4} = \frac{\%v\{\mathbf{b}\}}{16}$$

The probability of picking a  $\%v\{x\}$  marble and then not a  $\%v\{y\}$  marble is  $\%v\{a\}$ .

Type in  $\%v\{a\}$

#### 6) Assistment #93191 "93191 - Reading Tree Diagrams"

Based on the following tree diagram, what is the probability of picking a Green marble and then **not** a Green one?

**First Draw      Second Draw**



**Fill in:** 3/16 1/16**Hints:**

- The tree diagram **shows all the possible outcomes** that could occur.

The **first branch** shows all your **possible first picks**.

The **second branch** shows the **possible second picks**.

- For the first pick you want a **Green marble**.

Follow the diagram to that colored box in the second column.

From this you know that the probability of the **first event** occurring is  $\frac{1}{4}$

- Next you want to **not** pick a Green marble.

Follow the diagram to the boxes that go first to a Green colored box and then **NOT** to Green colored boxes.

From this you know that the probability of the **second event** occurring is  $\frac{3}{4}$

Following the diagram:

There are **3 desired outcomes** (the highlighted boxes in the last column).

While there are **16 possible outcomes** (total number of boxes in the last column).

$$\text{Probability} = \frac{\text{Number of desired outcomes}}{\text{Number of possible outcomes}}$$

$$\text{Chance of picking a Green marble and then not a Green marble} = \frac{3}{16}$$

Using the Multiplication Rule:

$$\text{Probability of the first event occurring} = \frac{1}{4}$$

$$\text{Probability of the second event occurring} = \frac{3}{4}$$

Multiplying the two probabilities:

$$\frac{1}{4} \times \frac{3}{4} = \frac{3}{16}$$

The probability of picking a Green marble and then not a Green marble is 3/16.

Type in 3/16

#### 7) Assistment #59968 "59968 - Permutations formula"

How many ways can three people be chosen for first, second, and third place from a group of  $\%v\{x\}$  people?

**Fill in:**

✓  $\%v\{y\}$

**Hints:**

- The first step in this problem is to identify whether it is a permutation or combination.

Lets start by listing some possible outcomes:

$P_1 P_2 P_3$

$P_1 P_3 P_2$

$P_2 P_1 P_3$

Looking at some possible outcomes, you can see that **order matters** for this problem.

$P_1 P_2 P_3 \neq P_1 P_3 P_2$

Since **order matters** in this problem, **it is a permutation**.

There are **too many possible permutations to list**, so we need to **use a formula**.

Remember the formula for permutations:

$$P(n,r) = \frac{n!}{(n-r)!}$$

**n = the total number of people**

**r = the number of people that you're selecting**

- In the given problem, where 3 people are being selected from a group of  $n$ :

$$n = n$$

$$r = 3$$

$$P(n,3) = \frac{n!}{(n-3)!}$$

- Expanding the factorials:

$$P(n,3) = \frac{n!}{(n-3)!}$$

$$P(n,3) = \frac{n \cdot (n-1) \cdot (n-2)}{1}$$

- Simplifying the fraction:

$$P(n,3) = n \cdot (n-1) \cdot (n-2)$$

$$P(n,3) = n \cdot (n-1) \cdot (n-2)$$

Enter:  $n \cdot (n-1) \cdot (n-2)$

#### 8) Assistment #93192 "93192 - 59968 - Permutations formula"

How many ways can three people be chosen for first, second, and third place from a group of 13 people?

**Fill in:**

✓ 1716

**Hints:**

- The first step in this problem is to identify whether it is a permutation or combination.

Lets start by listing some possible outcomes:

$$P_1 P_2 P_3$$

$$P_1 P_3 P_2$$

$$P_2 P_1 P_3$$

Looking at some possible outcomes, you can see that **order matters** for this problem.

$$P_1 P_2 P_3 \neq P_1 P_3 P_2$$

Since **order matters** in this problem, **it is a permutation**.

There are **too many possible permutations to list**, so we need to **use a formula**.

Remember the formula for permutations:

$$P(n,r) = \frac{n!}{(n-r)!}$$

**n = the total number of people**

**r = the number of people that you're selecting**

- In the given problem, where 3 people are being selected from a group of 13:

$$n = 13$$

$$r = 3$$

$$P(13,3) = \frac{13!}{(13-3)!}$$

- Expanding the factorials:

$$P(13,3) = \frac{13!}{(13-3)!}$$

$$P(13,3) = \frac{1*2*3*4*5*6*7*8*9*10 * 11*12*13}{1*2*3*4*5*6*7*8*9*10}$$

- Simplifying the fraction:

$$P(13,3) = 11*12*13$$

$$P(13,3) = 1716$$

Enter: 1716

### 9) Assistment #63593 "63593 - Combinations 2"

There are  $\%v\{x\}$  players on a basketball team. Only 5 players can be on the court at a time.

How many different groups of 5 players can the team put on the court?

**Algebra:**

✓  $\%v\{\text{ans}\}$

**Hints:**

- The first step in this problem is to identify whether it is a permutation or combination.

Lets start by listing some possible outcomes:

$$P_1 P_2 P_3$$

$$P_1 P_2 P_4$$

$$P_1 P_2 P_5$$

Looking at some possible outcomes, you can see that **order doesn't matter** for this problem.

$$P_1 P_2 P_3 = P_1 P_3 P_2$$

Since **order doesn't matter** in this problem, **it is a combination**.

There are **too many possible combinations to list**, so we need to **use a formula**.

Remember the formula for combinations:

$$C(n,r) = \frac{n!}{r!(n-r)!}$$

**n = the total number of people**

**r = the number of people that you're selecting**

- In the given problem were 5 people are being selected from a group of  $\%v\{x\}$ :

n:  $\%v\{x\}$

r: 5

$$C(\%v\{x\},5) = \frac{\%v\{f1\}}{\%v\{r\} * \%v\{f2\}}$$

- Simplifying the fraction:

$$C(\%v\{x\},5) = \frac{\%v\{ft\}}{\%v\{fb\}}$$

$$C(\%v\{x\},5) = \%v\{ans\}$$

Enter:  $\%v\{ans\}$

#### 10) Assistment #93193 "93193 - 63593 - Combinations 2"

There are 11 players on a basketball team. Only 5 players can be on the court at a time.

How many different groups of 5 players can the team put on the court?

**Algebra:**

✓ 462

**Hints:**

- The first step in this problem is to identify whether it is a permutation or combination.

Lets start by listing some possible outcomes:

$$P_1 P_2 P_3$$

$$P_1 P_2 P_4$$

$$P_1 P_2 P_5$$

Looking at some possible outcomes, you can see that **order doesn't matter** for this problem.

$$P_1 P_2 P_3 = P_1 P_3 P_2$$

Since **order doesn't matter** in this problem, **it is a combination**.

There are **too many possible combinations to list**, so we need to **use a formula**.

Remember the formula for combinations:

$$C(n,r) = \frac{n!}{r!(n-r)!}$$

**n = the total number of people**

**r = the number of people that you're selecting**

- In the given problem were 5 people are being selected from a group of 11:

n: 11

r: 5

$$C(11,5) = \frac{1*2*3*4*5*6*7*8*9*10 * 11}{1*2*3*4*5 * 1*2*3*4*5*6}$$

- Simplifying the fraction:

$$C(11,5) = \frac{7*8*9*10 * 11}{1*2*3*4*5}$$

$$C(11,5) = 462$$

Enter: 462

#### 11) Assistment #59969 "59969 - Picking Cards from a Deck"

A card is selected at random from a standard deck of 52 cards. Find the probability of choosing a %v{x} or a %v{color} card.

**Enter your answer as a fraction**

**Algebra:**

28/52

1/2

30/52

**Hints:**

- Remember what a deck of 52 cards looks like:



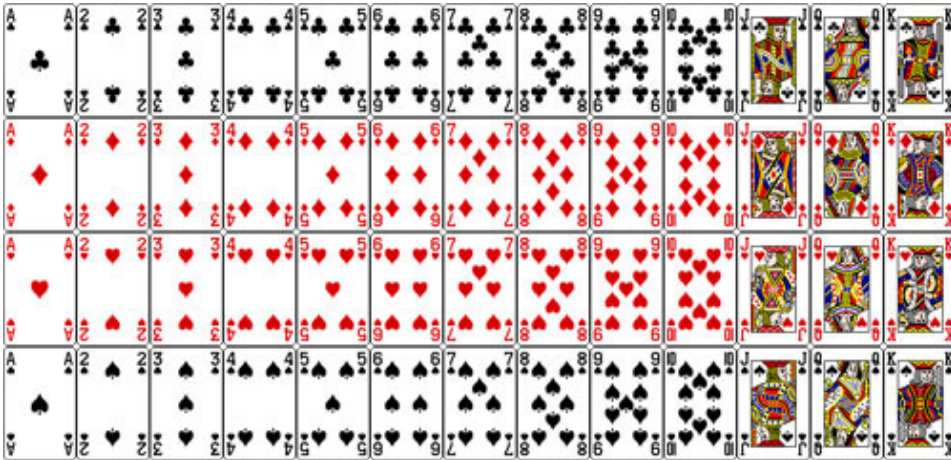

In a deck of cards, **half the cards are red** and half are black.

There are **four different suits: diamonds, clubs, hearts, and spades.**

There are **four of each of the number and face cards.**

- Therefore, of the 52 cards in the deck:

**26 will be %v{color}**

**4 will be %v{x}s**

- Don't forget that **2 of the %v{x}s are %v{color}**

$$\text{Probability} = \frac{\text{Number of Desired Outcomes}}{\text{Number of Possible Outcomes}}$$

$$\text{Probability of choosing a %v{color} card} = \frac{26}{52}$$

$$\text{Probability of choosing a non%v{color} %v{x} = } \frac{2}{52}$$

In this case, the number of desired outcomes is 26 + 2 and the Number of possible outcomes is 52

$$\cdot \frac{26 + 2}{52} = \frac{28}{52}$$

$$\text{Probability of choosing a %v{x} or a %v{color} card} = \frac{28}{52}$$

$$\text{Enter : } \frac{28}{52}$$

**12) Assistment #93194 "93194 - Picking Cards from a Deck"**

A card is selected at random from a standard deck of 52 cards. Find the probability of choosing a 6 or a black card.

**Enter your answer as a fraction**

**Algebra:**

✓ 28/52

✗ 1/2

✗ 30/52

**Hints:**

- Remember what a deck of 52 cards looks like:

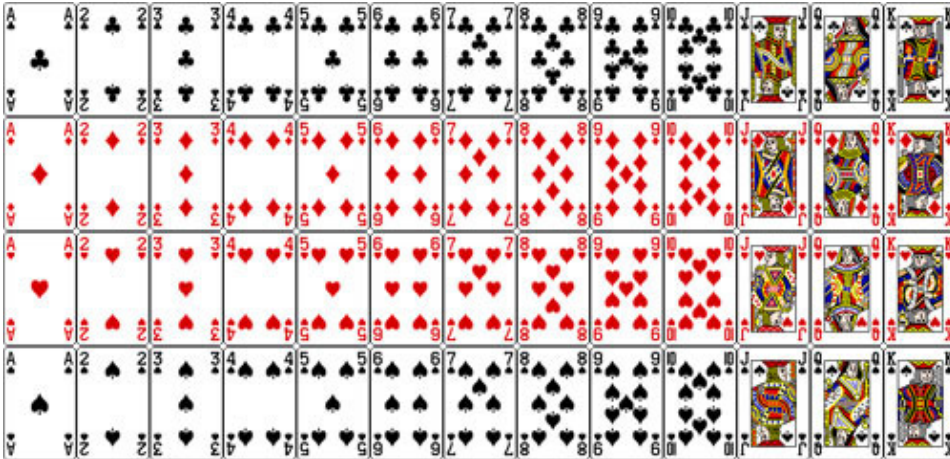

In a deck of cards, **half the cards are red** and half are black.

There are **four different suits: diamonds, clubs, hearts, and spades**.

There are **four of each of the number and face cards**.

- Therefore, of the 52 cards in the deck:

**26 will be black**

**4 will be 6s**

- Don't forget that **2 of the 6s are black**

Probability =  $\frac{\text{Number of Desired Outcomes}}{\text{Number of Possible Outcomes}}$

Probability of choosing a black card =  $\frac{26}{52}$

Probability of choosing a nonblack 6 =  $\frac{2}{52}$

In this case, the number of desired outcomes is 26 + 2 and the Number of possible outcomes is 52

$$\frac{26 + 2}{52} = \frac{28}{52}$$

$$\text{Probability of choosing a 6 or a black card} = \frac{28}{52}$$

Enter :  $\frac{28}{52}$

### 13) Assistment #58363 "58363 - Spinner 2"

To win a game, Jane must get a sum of  $v\{x\}$  on her next two spins of the arrow on the spinner shown below. All the sections of the spinner are of equal size.

What is the probability that the results of Yepa's next two spins will have a sum of  $v\{x\}$ ?

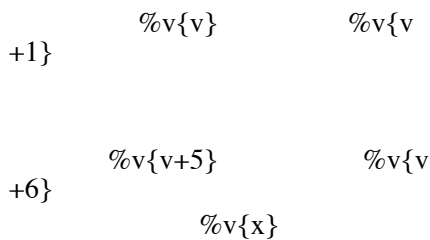

#### Algebra:

✓ 4/25

#### Hints:

- Remember:

$$\text{Probability} = \frac{\text{Number of Desired Outcomes}}{\text{Number of Possible Outcomes}}$$

- You can spin a total of  $v\{x\}$  by spinning a:

$v\{v\}$  and then  $v\{v+6\}$

$v\{v+6\}$  and then  $v\{v\}$

$v\{v+1\}$  and then  $v\{v+5\}$

$v\{v+5\}$  and then  $v\{v+1\}$

The possible spins and resulting sums are:

Spins	$\%v\{v\}$	$\%v\{v+1\}$	$\%v\{v+5\}$	$\%v\{v+6\}$	$\%v\{x\}$
$\%v\{v\}$	$\%v\{2*v\}$	$\%v\{2*v+1\}$	$\%v\{2*v+5\}$	$\%v\{2*v+6\}$	$\%v\{z\}$
$\%v\{v+1\}$	$\%v\{2*v+1\}$	$\%v\{2*v+2\}$	$\%v\{2*v+6\}$	$\%v\{2*v+7\}$	$\%v\{z+1\}$
$\%v\{v+5\}$	$\%v\{2*v+5\}$	$\%v\{2*v+6\}$	$\%v\{2*v+10\}$	$\%v\{2*v+11\}$	$\%v\{z+5\}$
$\%v\{v+6\}$	$\%v\{2*v+6\}$	$\%v\{2*v+7\}$	$\%v\{2*v+11\}$	$\%v\{2*v+12\}$	$\%v\{z+6\}$
$\%v\{x\}$	$\%v\{z\}$	$\%v\{z+1\}$	$\%v\{z+5\}$	$\%v\{z+6\}$	$\%v\{2*x\}$

There are **25** possible spin combinations.

**Number of Desired Outcomes**

**Probability** = \_\_\_\_\_

**Number of Possible Outcomes**

There are **4** ways for two spins to total  $\%v\{x\}$

While there are **25** possible spin combinations

This can be seen in the combinations table:

Spins	$\%v\{v\}$	$\%v\{v+1\}$	$\%v\{v+5\}$	$\%v\{v+6\}$	$\%v\{x\}$
$\%v\{v\}$	$\%v\{2*v\}$	$\%v\{2*v+1\}$	$\%v\{2*v+5\}$	$\%v\{2*v+6\}$	$\%v\{z\}$
$\%v\{v+1\}$	$\%v\{2*v+1\}$	$\%v\{2*v+2\}$	$\%v\{2*v+6\}$	$\%v\{2*v+7\}$	$\%v\{z+1\}$
$\%v\{v+5\}$	$\%v\{2*v+5\}$	$\%v\{2*v+6\}$	$\%v\{2*v+10\}$	$\%v\{2*v+11\}$	$\%v\{z+5\}$
$\%v\{v+6\}$	$\%v\{2*v+6\}$	$\%v\{2*v+7\}$	$\%v\{2*v+11\}$	$\%v\{2*v+12\}$	$\%v\{z+6\}$
$\%v\{x\}$	$\%v\{z\}$	$\%v\{z+1\}$	$\%v\{z+5\}$	$\%v\{z+6\}$	$\%v\{2*x\}$

Plugging these values into the probability formula:

$$\text{Probability} = \frac{\text{Number of Desired Outcomes } 4}{\text{Number of Possible Outcomes } 25} = \frac{4}{25}$$

The probability of two spins totaling  $\%v\{x\}$  is  $4/25$

Enter: **4/25**

#### 14) Assistment #93195 "93195 - Spinner 2"

To win a game, Jane must get a sum of 8 on her next two spins of the arrow on the spinner shown below. All the sections of the spinner are of equal size.

What is the probability that the results of Yepa's next two spins will have a sum of 8?

1            2  
 6            7  
              8

**Algebra:**

✓ 4/25

**Hints:**

- Remember:

$$\text{Probability} = \frac{\text{Number of Desired Outcomes}}{\text{Number of Possible Outcomes}}$$

- You can spin a total of 8 by spinning a:

1 and then 7

7 and then 1

2 and then 6

6 and then 2

The possible spins and resulting sums are:

Spins	1	2	6	7	8
1	2	3	7	8	9
2	3	4	8	9	10
6	7	8	12	13	14
7	8	9	13	14	15
8	9	10	14	15	16

There are **25** possible spin combinations.

$$\text{Probability} = \frac{\text{Number of Desired Outcomes}}{\text{Number of Possible Outcomes}}$$

There are **4 ways** for two spins to total 8

While there are **25 possible spin combinations**

This can be seen in the combinations table:

Spins	1	2	6	7	8
1	2	3	7	8	9
2	3	4	8	9	10
6	7	8	12	13	14
7	8	9	13	14	15
8	9	10	14	15	16

Plugging these values into the probability formula:

$$\text{Probability} = \frac{\text{Number of Desired Outcomes } 4}{\text{Number of Possible Outcomes } 25} = \frac{4}{25}$$

The probability of two spins totaling 8 is 4/25

Enter: 4/25

#### 15) Assistment #57940 "57940 - Independent vs. Dependent"

Independent vs. Dependent Events:

You have a bag with  $\%v\{x\}$  red marbles,  $\%v\{y\}$  blue marbles, and  $\%v\{z\}$  green marbles. What is the probability of picking a  $\%v\{a\}$  marble  $\%v\{\text{word}\}$  a  $\%v\{b\}$  marble with replacement? Leave your answer as a fraction

**Algebra:**

$\%v\{\text{answer}\}$

$\%v\{\text{wrong}\}$

**Hints:**

- First you need to determine if the problem is a dependent or an independent event .

In a dependent event, the second event depends on the outcome of the first event, so you have to multiply their probabilities.

In an independent event , the two events outcomes don't depend on one another, so you have to add their probabilities.

- The phrase " $\%v\{\text{word}\}$ " tells us that this problem is  $\%v\{\text{condition}\}$  event .
- To solve this you need to determine the chance of picking a  $\%v\{a\}$  marble , the chance of picking a  $\%v\{b\}$  marble , and then  $\%v\{\text{choice}\}$  them together to get the answer.
- For this case:  
The chance of picking a  $\%v\{a\}$  marble is:  $\%v\{a1\}/\%v\{\text{total}\}$   
The chance of picking a  $\%v\{b\}$  marble is:  $\%v\{b1\}/\%v\{\text{total}\}$
- Type in:  $\%v\{a1\}/\%v\{\text{total}\} \%v\{\text{symbol}\} \%v\{b1\}/\%v\{\text{total}\}$

#### 16) Assistment #93196 "93196 - 57940 - Independent vs. Dependent"

Independent vs. Dependent Events:

You have a bag with 3 red marbles, 4 blue marbles, and 2 green marbles. What is the probability of picking a red marble or a green marble with replacement? Leave your answer as a fraction

**Algebra:**

✓ 0.555555555555556

✗ 0.0740740740740741

### Hints:

- First you need to determine if the problem is a dependent or an independent event .

In a dependent event, the second event depends on the outcome of the first event, so you have to multiply their probabilities.

In an independent event , the two events outcomes don't depend on one another, so you have to add their probabilities.

- The phrase " **or**" tells us that this problem is **an independent event**.
- To solve this you need to determine the chance of picking a red marble, the chance of picking a green marble, and then add them together to get the answer.
- For this case:  
The chance of picking a red marble is:  $3/9$   
The chance of picking a green marble is:  $2/9$
- Type in:  $3/9 + 2/9$

### 17) Assistment #57737 "57737 - Permutations"

There are  $v\{x\}$  different books on a shelf, how many different ways can they be arranged?

#### Fill in:

✓  $v\{y\}$

### Hints:

- Let's try looking at a simpler problem. You have different 3 books, how many ways can you arrange them?

Try listing the possible orders you could have:

Book 1, Book 2, Book 3  
 Book 1, Book 3, Book 2  
 Book 2, Book 1, Book 3  
 Book 2, Book 3, Book 1  
 Book 3, Book 1, Book 2  
 Book 3, Book 2, Book 1

Notice that **order matters** in this problem as:

Book 1, Book 2, Book 3  $\neq$  Book 1, Book 3, Book 2

Try applying this strategy to the given problem.

- Another way to solve the problem is by using **factorials**. This is useful for when you have a **greater number of things** to arrange that you would be **unable to use the listing method** for.

The Formula for the number of possible permutations is:

$$P(n,r) = \frac{n!}{(n-r)!}$$

Where P is for **permutation**.

**n = Total number of things**

**r = how many you select**

i.e. For the example of 3 books the formula would look like:

$$n = 3$$

And  $n = r$  since all 3 books are used, so

$$r = 3$$

$$P(3,3) = \frac{3!}{(3-3)!}$$

$$P(3,3) = \frac{3!}{0!} = \frac{1*2*3}{1} = \frac{6}{1} = 6$$

For this example, there are **six possible permutations** for this situation. Try this for the given problem with  $\%v\{x\}$  books.

- For the given problem with  $\%v\{x\}$  books:

Using the permutations formula would give you:

$$P(\%v\{x\}, \%v\{x\}) = \frac{\%v\{x\}!}{(\%v\{x\} - \%v\{x\})!}$$

$$P(\%v\{x\}, \%v\{x\}) = \frac{\%v\{x\}!}{0!} = \frac{\%v\{\text{hint}\}}{1} = \frac{\%v\{y\}}{1} = \%v\{y\}$$

There are  $\%v\{y\}$  possible permutations.

Enter:  $\%v\{y\}$

### 18) Assistment #93197 "93197 - 57737 - Permutations"

There are 6 different books on a shelf, how many different ways can they be arranged?

**Fill in:**

✓ 720

**Hints:**

- Let's try looking at a simpler problem. You have different 3 books, how many ways can you arrange them?

Try listing the possible orders you could have:

Book 1, Book 2, Book 3  
 Book 1, Book 3, Book 2  
 Book 2, Book 1, Book 3  
 Book 2, Book 3, Book 1



Book 3, Book 1, Book 2  
 Book 3, Book 2, Book 1

Notice that **order matters** in this problem as:

Book 1, Book 2, Book 3  $\neq$  Book 1, Book 3, Book 2

Try applying this strategy to the given problem.

- Another way to solve the problem is by using **factorials**. This is useful for when you have a **greater number of things** to arrange that you would be **unable to use the listing method** for.

The Formula for the number of possible permutations is:

$$P(n,r) = \frac{n!}{(n-r)!}$$

Where P is for **permutation**.

**n = Total number of things**

**r = how many you select**

i.e. For the example of 3 books the formula would look like:

$$n = 3$$

And  $n = r$  since all 3 books are used, so

$$r = 3$$

$$P(3,3) = \frac{3!}{(3-3)!}$$

$$P(3,3) = \frac{3!}{0!} = \frac{1*2*3}{1} = \frac{6}{1} = 6$$

For this example, there are **six possible permutations** for this situation. Try this for the given problem with 6 books.

- For the given problem with 6 books:

Using the permutations formula would give you:

$$P(6,6) = \frac{6!}{(6-6)!}$$

$$P(6,6) = \frac{6!}{0!} = \frac{1*2*3*4*5*6}{1} = \frac{720}{1} = 720$$

There are 720 possible permutations.

Enter: 720

**19) Assistent #58408 "58408 - Probability with replacement"**

A bag of marbles contains  $\%v\{x\}$  green,  $\%v\{y\}$  red, and  $\%v\{z\}$  blue. Find the probability of picking a  $\%v\{a\}$  marble, putting it back in the bag, and then picking a  $\%v\{b\}$  marble. Leave your answer as a fraction

**Algebra:**

✓  $\%v\{f\}/\%v\{g\}$

**Scaffold:**

Let's try to break down this problem by looking at a similar one .

You have 1 red, 1 white, and 1 green marbles in a bag. What's the probability of picking a green marble, putting the marble back into the bag, and then picking a red marble?

First try to visualize the possible outcomes:

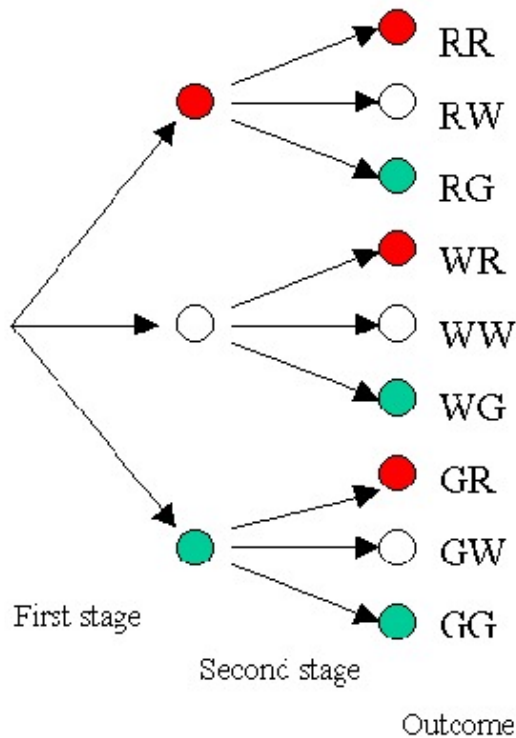

You want to pick a green marble and then a red marble. Follow the arrows on the diagram leading first to a green marble and then to a red marble as indicated by the **red arrows**.

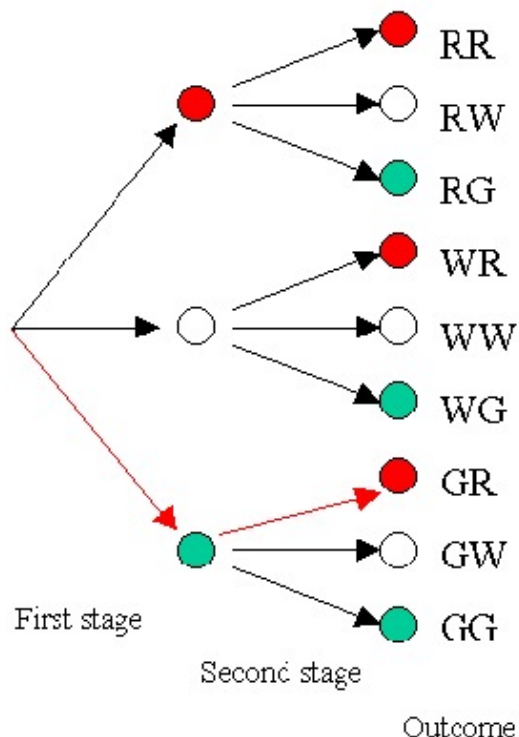

$$\text{Probability} = \frac{\# \text{ desired outcomes}}{\# \text{ of possible outcomes}}$$

There is only 1 possible outcome that results in picking a green marble and then a red marble (as indicated by the red arrows); while there are 9 possible outcomes.

By the multiplication rule you can also see this:

Chance picking a green marble x Chance picking a red marble

$$\frac{1}{3} \times \frac{1}{3} = \frac{1}{9}$$

### Multiple choice:

✓ I have read the problem and am ready to move on

### Scaffold:

Good, now let's try the original problem again:

A bag of marbles contains  $\%v{x}$  green,  $\%v{y}$  red, and  $\%v{z}$  blue ones. Find the probability of picking a  $\%v{a}$  marble, putting it back in the bag, and then picking a  $\%v{b}$  marble. Leave your answer as a fraction

### Algebra:

✓  $\%v{f}/\%v{g}$

### Hints:

- First you need to determine the chance of picking a  $\%v{a}$  marble. Then you need to determine the chance of picking a  $\%v{b}$  marble.

- Solving for these chances:

$$\text{Chance of picking a } \%v\{a\} \text{ marble} = \frac{\%v\{c\}}{\%v\{e\}}$$

$$\text{Chance of picking a } \%v\{b\} \text{ marble} = \frac{\%v\{d\}}{\%v\{e\}}$$

Since this is a dependent event, you can use the multiplication rule to find the combined probability.

- Combining the probabilities:

$$\frac{\%v\{c\}}{\%v\{e\}} \times \frac{\%v\{d\}}{\%v\{e\}} = \frac{\%v\{f\}}{\%v\{g\}}$$

$$\text{The chance of picking a } \%v\{a\} \text{ marble, putting it back in the bag, and then picking a } \%v\{b\} = \frac{\%v\{f\}}{\%v\{g\}}$$

$$\text{Enter : } \frac{\%v\{f\}}{\%v\{g\}}$$

### Scaffold:

Let's try to break down this problem by looking at a similar one .

You have 1 red, 1 white, and 1 green marbles in a bag . What's the probability of picking a green marble, putting it back, and then picking a red marble?

Try to list all the possible combinations of marbles you could pick.

You could pick:

Red then Red, Red then Green, Red then White, Green then Green, Green then Red, Green then White, White then White, White then Red, White then Green.

In shorthand: RR, RG, RW, GG, GR, GW, WW, WR, WG

You want to pick a green marble and then a red marble.

GR

There are 9 possible combinations while GR is only 1 of the combinations.

$$\text{Probability} = \frac{\text{number of desired combinations}}{\text{number of possible combinations}}$$

Probability of picking a green marble, putting it back in the bag, and then picking a red one =  $\frac{1}{9}$

**Multiple choice:**

✓ I have read the problem and am ready to move on

**Scaffold:**

Good, now let's try the original problem again:

A bag of marbles contains  $\%v\{x\}$  green,  $\%v\{y\}$  red, and  $\%v\{z\}$  blue ones. Find the probability of picking a  $\%v\{a\}$  marble, putting it back in the bag, and then picking a  $\%v\{b\}$  marble. Leave your answer as a fraction

**Algebra:**

✓  $\%v\{f\}/\%v\{g\}$

**Hints:**

- First you need to determine the chance of picking a  $\%v\{a\}$  marble. Then you need to determine the chance of picking a  $\%v\{b\}$  marble.
- Solving for these chances:

$$\text{Chance of picking a } \%v\{a\} \text{ marble} = \frac{\%v\{c\}}{\%v\{e\}}$$

$$\text{Chance of picking a } \%v\{b\} \text{ marble} = \frac{\%v\{d\}}{\%v\{e\}}$$

Since this is a dependent event, you can use the multiplication rule to find the combined probability.

- Combining the probabilities:

$$\frac{\%v\{c\}}{\%v\{e\}} * \frac{\%v\{d\}}{\%v\{e\}} = \frac{\%v\{f\}}{\%v\{g\}}$$

The chance of picking a  $\%v\{a\}$  marble, putting it back in the bag, and then picking a  $\%v\{b\}$  marble is:  $\frac{\%v\{f\}}{\%v\{g\}}$

Enter:  $\frac{\%v\{f\}}{\%v\{g\}}$

**20) Assistment #93198 "93198 - 58408 - Probability with replacement"**

A bag of marbles contains 1 green, 1 red, and 3 blue. Find the probability of picking a red marble, putting it back in the bag, and then picking a blue marble. Leave your answer as a fraction

**Algebra:**

✓ 3/25

**Scaffold:**

Let's try to break down this problem by looking at a similar one .

You have 1 red, 1 white, and 1 green marbles in a bag . What's the probability of picking a green marble, putting the marble back into the bag, and then picking a red marble?

First try to visualize the possible outcomes:

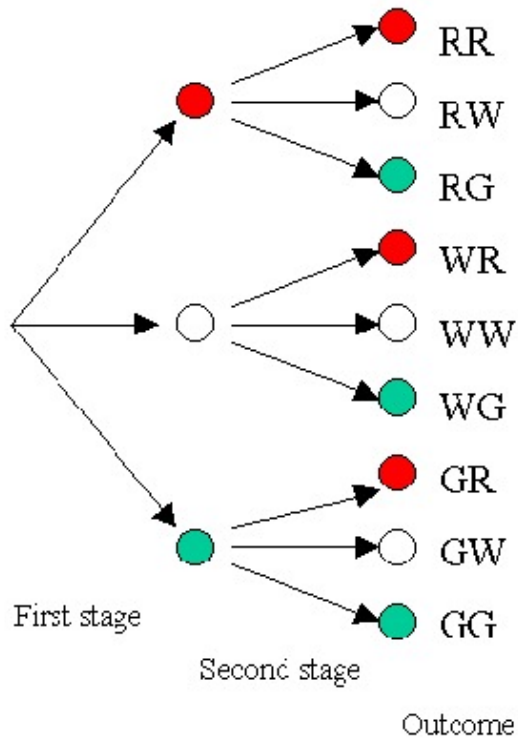

You want to pick a green marble and then a red marble. Follow the arrows on the diagram leading first to a green marble and then to a red marble as indicated by the red arrows.

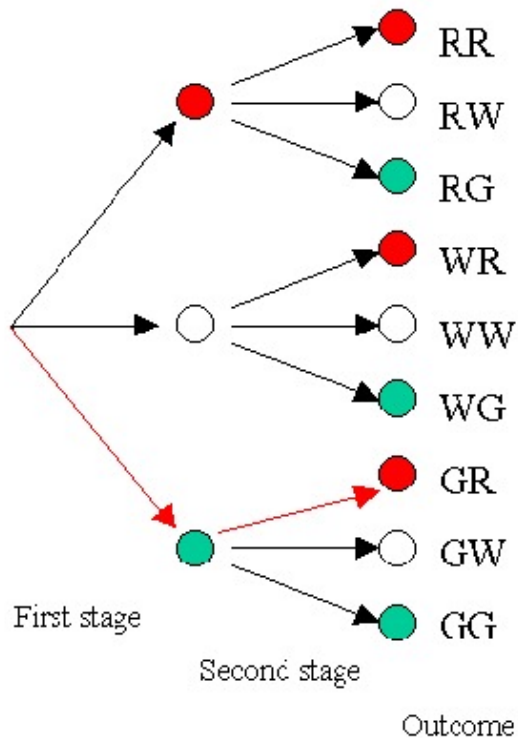

$$\text{Probability} = \frac{\# \text{ desired outcomes}}{\# \text{ of possible outcomes}}$$

There is only 1 possible outcome that results in picking a green marble and then a red marble (as indicated by the red arrows); while there are 9 possible outcomes.

By the multiplication rule you can also see this:

Chance picking a green marble x Chance picking a red marble

$$\frac{1}{3} \times \frac{1}{3} = \frac{1}{9}$$

### Multiple choice:

✓ I have read the problem and am ready to move on

### Scaffold:

Good, now let's try the original problem again:

A bag of marbles contains 1 green, 1 red, and 3 blue ones. Find the probability of picking a red marble, putting it back in the bag, and then picking a blue marble. Leave your answer as a fraction

### Algebra:

✓  $\frac{3}{25}$

### Hints:

- First you need to determine the chance of picking a red marble. Then you need to determine the chance of picking a blue marble.

- Solving for these chances:

$$\text{Chance of picking a red marble} = \frac{1}{5}$$

$$\text{Chance of picking a blue marble} = \frac{3}{5}$$

Since this is a dependent event, you can use the multiplication rule to find the combined probability.

- Combining the probabilities:

$$\frac{1}{5} \times \frac{3}{5} = \frac{3}{25}$$

$$\text{The chance of picking a red marble, putting it back in the bag, and then picking a blue} = \frac{3}{25}$$

$$\text{Enter : } \frac{3}{25}$$

### Scaffold:

Let's try to break down this problem by looking at a similar one .

You have 1 red, 1 white, and 1 green marbles in a bag. What's the probability of picking a green marble, putting it back, and then picking a red marble?

Try to list all the possible combinations of marbles you could pick.

You could pick:

Red then Red, Red then Green, Red then White, Green then Green, Green then Red, Green then White, White then White, White then Red, White then Green.

In shorthand: RR, RG, RW, GG, GR, GW, WW, WR, WG

You want to pick a green marble and then a red marble.

GR

There are 9 possible combinations while GR is only 1 of the combinations.

$$\text{Probability} = \frac{\text{number of desired combinations}}{\text{number of possible combinations}}$$



Probability of picking a green marble, putting it back in the bag, and then picking a red one =  $\frac{1}{9}$

**Multiple choice:**

✓ I have read the problem and am ready to move on

**Scaffold:**

Good, now let's try the original problem again:

A bag of marbles contains 1 green, 1 red, and 3 blue ones. Find the probability of picking a red marble, putting it back in the bag, and then picking a blue marble. Leave your answer as a fraction

**Algebra:**

✓  $\frac{3}{25}$

**Hints:**

- First you need to determine the chance of picking a red marble. Then you need to determine the chance of picking a blue marble.
- Solving for these chances:

$$\text{Chance of picking a red marble} = \frac{1}{5}$$

$$\text{Chance of picking a blue marble} = \frac{3}{5}$$

Since this is a dependent event, you can use the multiplication rule to find the combined probability.

- Combining the probabilities:

$$\frac{1}{5} * \frac{3}{5} = \frac{3}{25}$$

The chance of picking a red marble, putting it back in the bag, and then picking a blue marble is :  $\frac{3}{25}$

Enter :  $\frac{3}{25}$

**21) Assistment #58782 "58782 - 58782- Probability with replacement list method"**

A bag of marbles contains  $\%v\{x\}$  green,  $\%v\{y\}$  red, and  $\%v\{z\}$  blue ones. Find the probability of choosing a  $\%v\{a\}$  marble, putting it back in the bag, and then **not** picking a  $\%v\{b\}$  marble.

Leave your answer as a fraction

**Algebra:**

✗  $\%v\{k\}/\%v\{g\}$

✓  $\%v\{i\}/\%v\{g\}$

**Scaffold:**

Let's try to break down this problem by looking at a similar one .

You have 1 red, 1 white, and 1 green marbles in a bag . What's the probability of picking a green marble, putting the marble back into the bag, and then picking a red marble?

First try to visualize the possible outcomes:

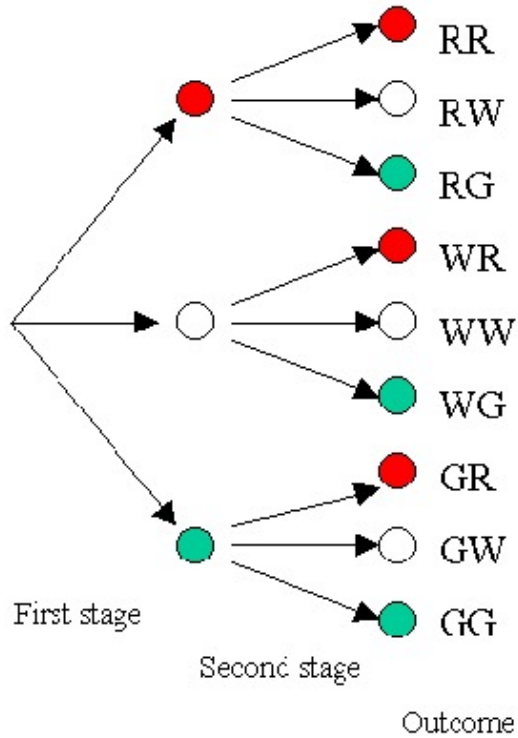

You want to pick a green marble and then a red marble. Follow the arrows on the diagram leading first to a green marble and then to a red marble as indicated by the **red arrows**.

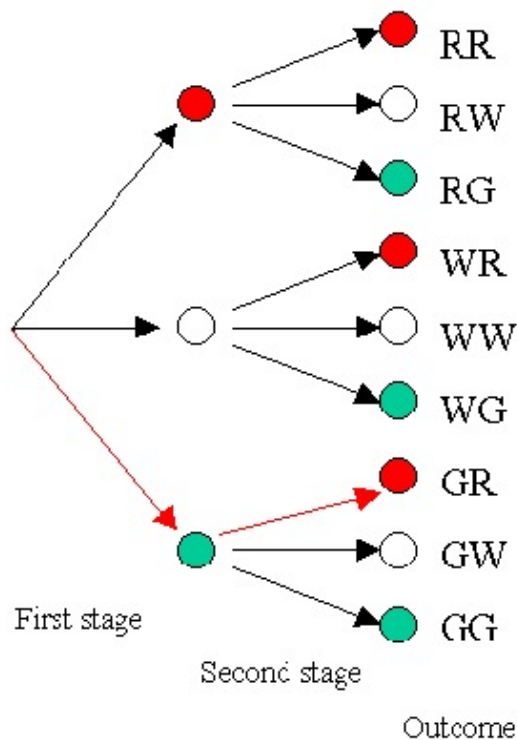

Probability=

# desired outcomes

# of possible outcomes.

# desired outcomes/# of possible outcomes.

There is only 1 possible outcome that results in picking a green marble and then a red marble (as indicated by the red arrows); while there are 9 possible outcomes.

By the multiplication rule you can also see this:

Chance picking a green marble x Chance picking a red marble

$$1/3 \times 1/3 = 1/9$$

**Multiple choice:**

✓ I have read the problem and am ready to move on

**Scaffold:**

Good, now lets try the original problem again:

A bag of marbles contains  $\%v\{x\}$  green,  $\%v\{y\}$  red, and  $\%v\{z\}$  blue ones. Find the probability of choosing a  $\%v\{a\}$  marble followed by a  $\%v\{b\}$  marble with replacement. Leave your answer as a fraction

**Algebra:**

✓  $\%v\{f\}/\%v\{g\}$

**Hints:**

- First you need to determine the chance of picking a  $\%v\{a\}$  marble. Then you need to determine the chance of picking a  $\%v\{b\}$  marble.
- Solving for these chances:  
 Chance picking  $\%v\{a\}$  marble:  $\%v\{c\}/\%v\{e\}$   
 Chance picking  $\%v\{b\}$  marble:  $\%v\{d\}/\%v\{e\}$

Since this is a dependent event, you can use the multiplication rule to find the combined probability.

- Combining the probabilities:

$$\frac{c}{e} * \frac{d}{e} = \frac{f}{g}$$

The chance of picking a  $\frac{a}{b}$  marble, followed by a  $\frac{b}{g}$  marble is  $\frac{f}{g}$

Enter  $\frac{f}{g}$

### Scaffold:

Let's try to break down this problem by looking at a similar one.

You have 3 red, 4 white, and 2 green marbles in a bag. What's the probability of picking a green marble, putting it back, and then **not** picking a red marble?

You can solve this using the formula:

$$P(\text{Green, Not Red}) = P(\text{Green}) * P(\text{Not Red})$$

$$P(\text{Green}) = \frac{2}{9}$$

$$P(\text{Not Red}) = \frac{6}{9}$$

$$P(\text{Green, Not Red}) = \frac{2}{9} * \frac{6}{9} = \frac{12}{81}$$

$$P(\text{Green, Not Red}) = \frac{12}{81}$$

### Multiple choice:

- I have read and understand the problem and am ready to move on

### Scaffold:

Good, now let's try the original problem again:

A bag of marbles contains  $x$  green,  $y$  red, and  $z$  blue ones. Find the probability of choosing a  $\frac{a}{b}$  marble, putting it back in the bag, and then not picking a  $\frac{b}{c}$  marble. Leave your answer as a fraction

### Algebra:

$\frac{\text{answer}}$

$\frac{\text{wrong}}$

### Hints:

- First you need to determine the chance of picking a  $\frac{a}{b}$  marble. Then you need to determine the chance of **not** picking a  $\frac{b}{c}$  marble.
- Solving for these chances:

$$\text{Chance of picking a } \frac{a}{b} \text{ marble} = \frac{c}{e}$$

$$\text{Chance of not picking a } \%v\{b\} \text{ marble} = \frac{\%v\{h\}}{\%v\{e\}}$$

Since this is a dependent event, you can use the multiplication rule to find the combined probability.

- Combining the probabilities:

$$\frac{\%v\{c\}}{\%v\{e\}} * \frac{\%v\{h\}}{\%v\{e\}} = \frac{\%v\{i\}}{\%v\{g\}}$$

The chance of picking a  $\%v\{a\}$  marble, putting it back in the bag, and then **not** picking a  $\%v\{b\}$  marble is :  $\frac{\%v\{i\}}{\%v\{g\}}$

Enter :  $\frac{\%v\{i\}}{\%v\{g\}}$

#### Hints:

- There are no hints in this problem. The next hint will reveal the answer.

The probability of choosing a red marble, putting it back in the bag, and then **not** picking a blue marble is  $\frac{12}{64}$

Please type 12 / 64

#### 22) Assistment #93199 "93199 - 58782 - 58782- Probability with replacement list method"

A bag of marbles contains 2 green, 4 red, and 4 blue ones. Find the probability of choosing a red marble, putting it back in the bag, and then **not** picking a blue marble.

Leave your answer as a fraction

#### Algebra:

 16/100

 24/100

#### Scaffold:

Let's try to break down this problem by looking at a similar one .

You have 1 red, 1 white, and 1 green marbles in a bag . What's the probability of picking a green marble, putting the marble back into the bag, and then picking a red marble?

First try to visualize the possible outcomes:

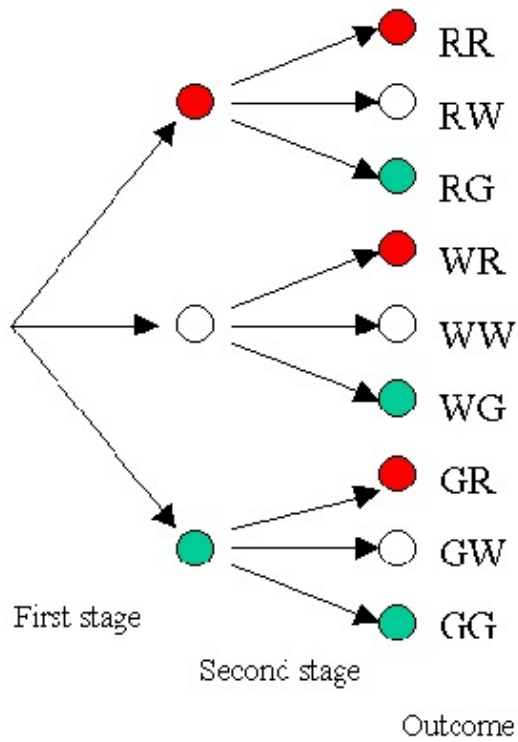

You want to pick a **green** marble and then a **red** marble. Follow the arrows on the diagram leading first to a **green** marble and then to a **red** marble as indicated by the **red arrows**.

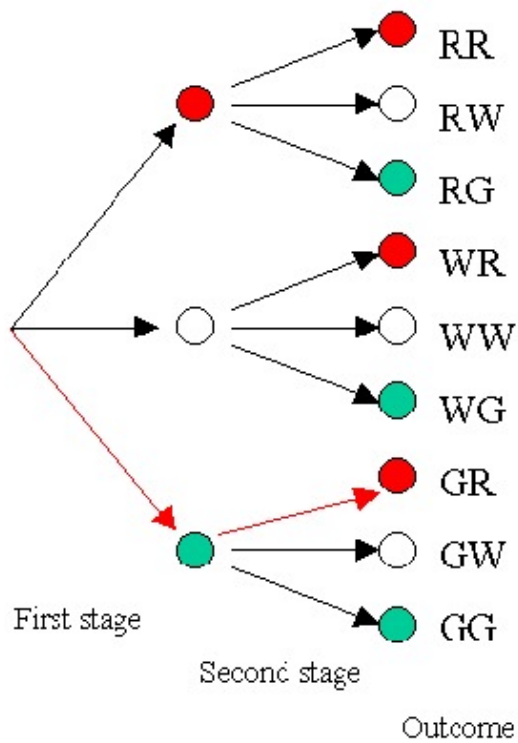

Probability=  
# desired outcomes

# of possible outcomes.

# desired outcomes/# of possible outcomes.

There is only 1 possible outcome that results in picking a green marble and then a red marble (as indicated by the red arrows); while there are 9 possible outcomes.  
By the multiplication rule you can also see this:

Chance picking a green marble x Chance picking a red marble

$$1/3 \times 1/3 = 1/9$$

**Multiple choice:**

✓ I have read the problem and am ready to move on

**Scaffold:**

Good, now lets try the original problem again:

A bag of marbles contains 2 green, 4 red, and 4 blue ones. Find the probability of choosing a red marble followed by a blue marble with replacement. Leave your answer as a fraction

**Algebra:**

✓ 16/100

**Hints:**

- First you need to determine the chance of picking a red marble. Then you need to determine the chance of picking a blue marble.
- Solving for these chances:  
Chance picking red marble: 4/10  
Chance picking blue marble: 4/10  
Since this is a dependent event, you can use the multiplication rule to find the combined probability.
- Combining the probabilities:  
 $4/10 * 4/10 = 16/100$   
The chance of picking a red marble, followed by a blue marble is 16/100  
Enter 16/100

**Scaffold:**

Let's try to break down this problem by looking at a similar one .

You have 3 red, 4 white, and 2 green marbles in a bag . What's the probability of picking a green marble, putting it back, and then **not** picking a red marble?

You can solve this using the formula:

$$P(\text{Green, Not Red}) = P(\text{Green}) * P(\text{Not Red})$$

$$P(\text{Green}) = \frac{2}{9}$$

$$P(\text{Not Red}) = \frac{6}{9}$$

$$P(\text{Green, Not Red}) = \frac{2}{9} \times \frac{6}{9} = \frac{12}{81}$$

$$P(\text{Green, Not Red}) = \frac{12}{81}$$

**Multiple choice:**

- I have read and understand the problem and am ready to move on

**Scaffold:**

Good, now let's try the original problem again:

A bag of marbles contains 2 green, 4 red, and 4 blue ones. Find the probability of choosing a red marble, putting it back in the bag, and then not picking a blue marble. Leave your answer as a fraction

**Algebra:**

- 0.24  
 0.16

**Hints:**

- First you need to determine the chance of picking a red marble. Then you need to determine the chance of **not** picking a blue marble.
- Solving for these chances:

$$\text{Chance of picking a red marble} = \frac{4}{10}$$

$$\text{Chance of **not** picking a blue marble} = \frac{6}{10}$$

Since this is a dependent event, you can use the multiplication rule to find the combined probability.

- Combining the probabilities:

$$\frac{4}{10} * \frac{6}{10} = \frac{24}{100}$$

The chance of picking a red marble, putting it back in the bag, and then **not** picking a blue marble is :  $\frac{24}{100}$

Enter :  $\frac{24}{100}$

**Hints:**

- There are no hints in this problem. The next hint will reveal the answer.



The probability of choosing a red marble, putting it back in the bag, and then **not** picking a blue marble is  $\frac{12}{64}$

Please type 12 / 64

23) Assistment #60339 "60339 - Probability - Compound - Rolling a Die"

When rolling a six-sided die, what is the probability of getting a  $\%v\{v1\}$  on the first roll, and then a  $\%v\{v2\}$  on the second roll?

**Algebra:**

✓ 1/36

✗ 1/6

✗ 1/3

**Hints:**

- Remember:

$$\text{Probability} = \frac{\text{Number of Desired Outcomes}}{\text{Number of Possible Outcomes}}$$

- First you can start by listing all the possible outcomes:

1,1	1,2	1,3	1,4	1,5	1,6
2,1	2,2	2,3	2,4	2,5	2,6
3,1	3,2	3,3	3,4	3,5	3,6
4,1	4,2	4,3	4,4	4,5	4,6
5,1	5,2	5,3	5,4	5,5	5,6
6,1	6,2	6,3	6,4	6,5	6,6

- In this problem, you want to roll a  $\%v\{v1\}$  and then a  $\%v\{v2\}$ :

$(\%v\{v1\}, \%v\{v2\})$

**This is only 1 of the possible outcomes.**

- So putting this all together:

$$\text{Probability} = \frac{\text{Number of Desired Outcomes}}{\text{Number of Possible Outcomes}}$$

There are **36 possible outcomes** while **only 1 outcome is the desired outcome**  $(\%v\{v1\}, \%v\{v2\})$

$$\frac{\text{Number of Desired Outcomes}}{\text{Number of Possible Outcomes}} = \frac{1}{36}$$

So the probability of rolling a  $v_1$  and then a  $v_2$  is  $\frac{1}{36}$

Enter: 1/36

#### 24) Assistment #93200 "93200 - Probability - Compound - Rolling a Die"

When rolling a six-sided die, what is the probability of getting a **3** on the first roll, and then a **5** on the second roll?

#### Algebra:

✓ 1/36

✗ 1/6

✗ 1/3

#### Hints:

- Remember:

$$\text{Probability} = \frac{\text{Number of Desired Outcomes}}{\text{Number of Possible Outcomes}}$$

- First you can start by listing all the possible outcomes:

1,1	1,2	1,3	1,4	1,5	1,6
2,1	2,2	2,3	2,4	2,5	2,6
3,1	3,2	3,3	3,4	3,5	3,6
4,1	4,2	4,3	4,4	4,5	4,6
5,1	5,2	5,3	5,4	5,5	5,6
6,1	6,2	6,3	6,4	6,5	6,6

- In this problem, you want to roll a **3** and then a **5**:

**(3,5)**

**This is only 1 of the possible outcomes.**

- So putting this all together:

$$\text{Probability} = \frac{\text{Number of Desired Outcomes}}{\text{Number of Possible Outcomes}}$$

There are **36 possible outcomes** while **only 1 outcome is the desired outcome (3,5)**

$$\frac{\text{Number of Desired Outcomes} \quad 1}{\text{Number of Possible Outcomes} \quad 36} = \frac{1}{36}$$

So the probability of rolling a 3 and then a 5 is  $\frac{1}{36}$

Enter: 1/36

---

Skill	Class
Finding Parallel Equations	9th

Mastery Problem Set #10598	Number of Templates 3
Number to Master 5	Number of Attempts 10

## Templates:

Here is the equation of a line.

$$y = \frac{4}{5}x + 2$$

Find the equation for the line that is parallel to this line and has a y-intercept of 1.

Give your answer in slope-intercept form.  $y = \underline{\hspace{2cm}}$

[Comment on this question](#)

[Show me hint 1 of 4](#)

Type your answer below (mathematical expression):

[Submit Answer](#)

- 57753
  - Slope numerator is random between 1 and 10
  - Slope denominator is random between 1 and 10
  - Y-intercept is random between 1 and 10

Here is the equation of a line.

$$y = 3x + 5$$

Find the equation for the line that is parallel to this line and has a y-intercept of 6.

Give your answer in slope-intercept form.  $y =$  \_\_\_\_\_

[Comment on this question](#)

[Show me hint 1 of 4](#)

Type your answer below (mathematical expression):

[Submit Answer](#)

- 73663
  - Slope is random between 1 and 12
  - Y-intercept is random between 1 and 10
- 73664
  - Slope is random between -12 and -1
  - Y-intercept is random between 1 and 10

Template by: Christopher Kevorkian

## Problem Set "Finding Parallel Equations - Printout" id:[11066]

### 1) Assistent #57753 "57753 - Create Parallel Line"

Here is the equation of a line.

$$y = \frac{\%v\{m1\}}{\%v\{m2\}} x + \%v\{a\}$$

Find the equation for the line that is parallel to this line and has a y-intercept of  $\%v\{b\}$ .

Give your answer in slope-intercept form.  $y = \underline{\hspace{2cm}}$

**Algebra:**

✓  $\%v\{m1/m2\}x + \%v\{b\}$

**Hints:**

- Linear equations can be written in this form where m is the slope and b is the y-intercept.

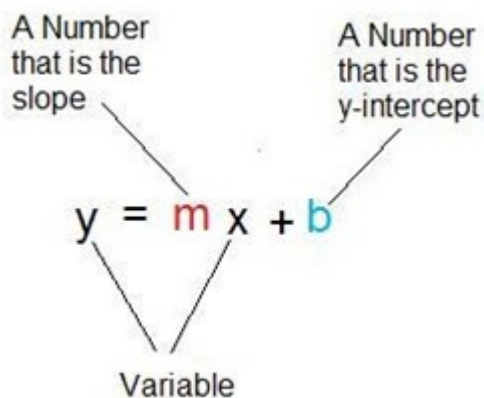

- Parallel lines have have identical slopes.

The slope of the given line is  $\frac{\%v\{m1\}}{\%v\{m2\}}$

Therefore the slope of the new line is  $\frac{\%v\{m1\}}{\%v\{m2\}}$

- Now use the new slope to form a new equation with a y-intercept of  $\%v\{b\}$ .

$$y = \frac{\%v\{m1\}}{\%v\{m2\}} x + \%v\{b\}$$

This is the equation for the line parallel to the starting equation and having a y-intercept of  $\%v\{b\}$ .

Type:  $y = (\%v\{m1\}/\%v\{m2\})x + \%v\{b\}$

---

2) Assistent #90102 "90102 - 57753 - Create Parallel Line"

Here is the equation of a line.

$$y = \frac{9}{5}x + 6$$

Find the equation for the line that is parallel to this line and has a y-intercept of 3.

Give your answer in slope-intercept form.  $y = \underline{\hspace{2cm}}$

**Algebra:**

✓  $1.8x+3$

**Hints:**

- Linear equations can be written in this form where m is the slope and b is the y-intercept.

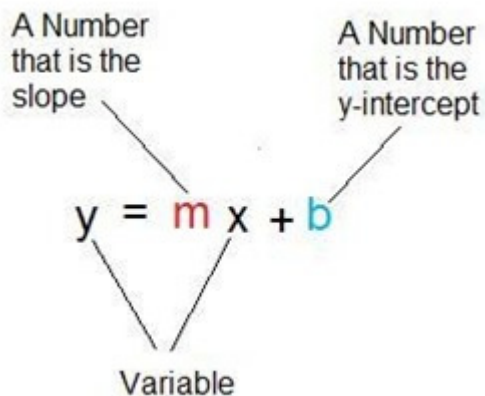

- Parallel lines have have identical slopes.
- 

The slope of the given line is  $-\frac{9}{5}$

Therefore the slope of the new line is  $-\frac{9}{5}$

- Now use the new slope to form a new equation with a y-intercept of 3.

$$y = -\frac{9}{5}x + 3$$

This is the equation for the line parallel to the starting equation and having a y-intercept of 3.  
Type:  $y = (9/5)x+3$

---

3) Assistent #73663 "73663 - 57753 - Create Parallel Line"

Here is the equation of a line.

$$y = m x + a$$

Find the equation for the line that is parallel to this line and has a y-intercept of  $b$ .

Give your answer in slope-intercept form.  $y =$  \_\_\_\_\_

**Algebra:**

✓  $m x + b$

**Hints:**

- Linear equations can be written in this form where  $m$  is the slope and  $b$  is the y-intercept.

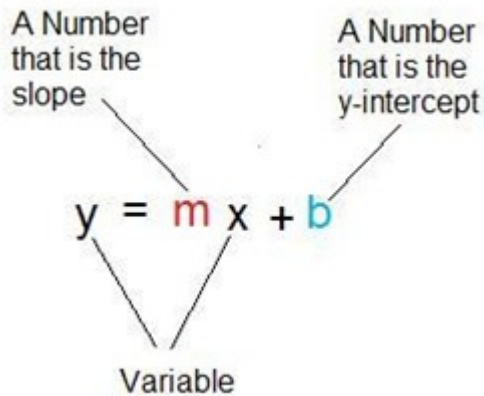

- Parallel lines have identical slopes.
- The slope of the given line is  $m$

Therefore the slope of the new line is  $m$

- Now use the new slope to form a new equation with a y-intercept of  $b$ .

$$y = m x + b$$

This is the equation for the line parallel to the starting equation and having a y-intercept of  $b$ .

Type:  $y = m x + b$

#### 4) Assistentment #90062 "90062 - 57753 - Create Parallel Line"

Here is the equation of a line.

$$y = 2x + 6$$

Find the equation for the line that is parallel to this line and has a y-intercept of 9.

Give your answer in slope-intercept form.  $y =$  \_\_\_\_\_

**Algebra:**

✓  $2x + 9$

**Hints:**



- Linear equations can be written in this form where  $m$  is the slope and  $b$  is the y-intercept.

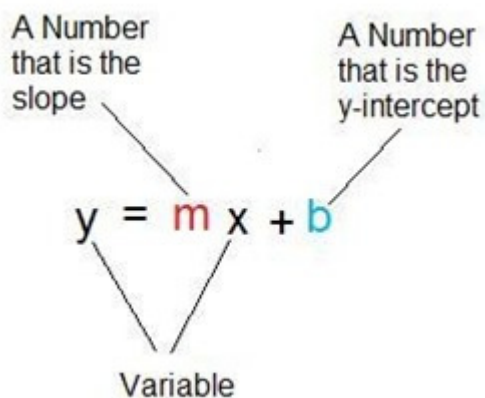

- Parallel lines have identical slopes.
  - The slope of the given line is  $2$
- Therefore the slope of the new line is  $2$
- Now use the new slope to form a new equation with a y-intercept of  $9$ .

$$y = 2x + 9$$

This is the equation for the line parallel to the starting equation and having a y-intercept of  $9$ .  
Type:  $y = 2x + 9$

### 5) Assisment #73664 "73664 - 57753 - Create Parallel Line"

Here is the equation of a line.

$$y = m x + a$$

Find the equation for the line that is parallel to this line and has a y-intercept of  $b$ .

Give your answer in slope-intercept form.  $y = \underline{\hspace{2cm}}$

**Algebra:**

✓  $m x + b$

**Hints:**

- Linear equations can be written in this form where m is the slope and b is the y-intercept.

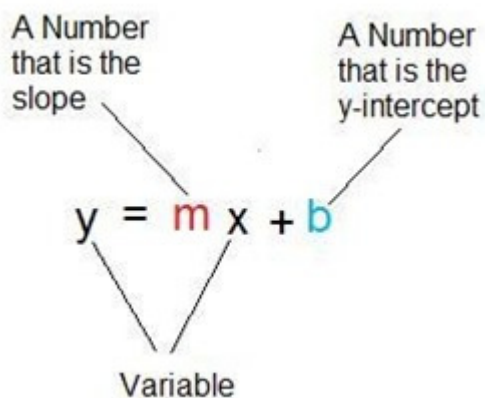

- Parallel lines have identical slopes.
- The slope of the given line is  $m$
- Therefore the slope of the new line is  $m$
- Now use the new slope to form a new equation with a y-intercept of  $b$ .

$$y = mx + b$$

This is the equation for the line parallel to the starting equation and having a y-intercept of  $b$ .  
 Type:  $y = mx + b$

**6) Assisment #90084 "90084 - 57753 - Create Parallel Line"**

Here is the equation of a line.

$$y = -5x + 8$$

Find the equation for the line that is parallel to this line and has a y-intercept of 9.

Give your answer in slope-intercept form.  $y = \underline{\hspace{2cm}}$

**Algebra:**

✓  $-5x+9$

**Hints:**

- Linear equations can be written in this form where  $m$  is the slope and  $b$  is the y-intercept.

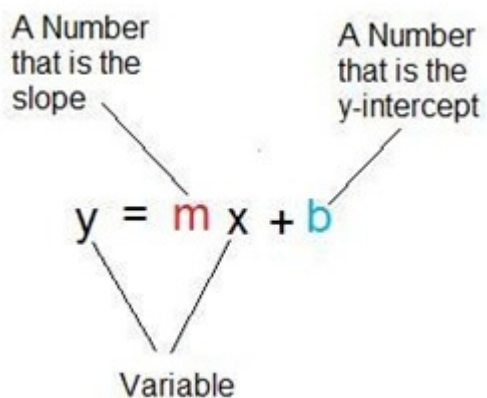

- Parallel lines have identical slopes.
  - The slope of the given line is  $-5$
- Therefore the slope of the new line is  $-5$
- Now use the new slope to form a new equation with a y-intercept of  $9$ .

$$y = -5x + 9$$

This is the equation for the line parallel to the starting equation and having a y-intercept of  $9$ .  
Type:  $y = -5x + 9$

---

Skill <b>Finding Perpendicular Equations</b>	Class <b>9th</b>
---	---------------------

Mastery Problem Set <input type="text" value="#10599"/>	Number of Templates <input type="text" value="5"/>
Number to Master <input type="text" value="5"/>	Number of Attempts <input type="text" value="10"/>

## Templates:

Here is the equation of a line.

$$y = \frac{4}{10}x + 5$$

Find the equation for the line that is perpendicular to this line and has a y-intercept of 3.

Give your answer in slope-intercept form.  $y = \underline{\hspace{2cm}}$

[Comment on this question](#)

[Show me hint 1 of 5](#)

Type your answer below (mathematical expression):

[Submit Answer](#)

- 57337
  - Slope numerator is random between 2 and 12
  - Slope denominator is random between 2 and 12
  - Y-intercept is random between 1 and 12

- 73665
  - Slope numerator is random between -12 and -2
  - Slope denominator is random between 2 and 12
  - Y-intercept is random between 1 and 12
- 78129
  - Slope numerator is 1.
  - Slope denominator is random between 2 and 12.
  - Y-intercept is random between 1 and 12

Here is the equation of a line.

$$y = 5x + 7$$

Find the equation for the line that is perpendicular to this line and has a y-intercept of 11.

Give your answer in slope-intercept form.  $y =$  \_\_\_\_\_

[Comment on this question](#)

[Show me hint 1 of 5](#)

Type your answer below (mathematical expression):

[Submit Answer](#)

- 74969
  - Slope is random between 1 and 12
  - Y-intercept is random between 1 and 10
- 74970
  - Slope is random between -12 and -1
  - Y-intercept is random between 1 and 10

Template by: Christopher Kevorkian

**Problem Set "Finding Perpendicular Equations - Printout"** id:[11067]

**1) Assistent #57337 "57337 - Create Perpendicular Line"**

Here is the equation of a line.

$$y = \frac{\%v\{m1\}}{\%v\{m2\}} x + \%v\{a\}$$

Find the equation for the line that is perpendicular to this line and has a y-intercept of  $\%v\{b\}$ .

Give your answer in slope-intercept form.  $y = \underline{\hspace{2cm}}$

**Algebra:**

✓  $\%v\{-m2/m1\}x + \%v\{b\}$

**Hints:**

- Linear equations can be written in this form where m is the slope and b is the y-intercept.

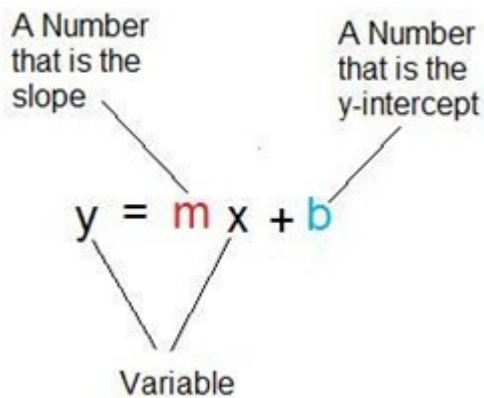

- Lines that are perpendicular will have reciprocal and opposite slopes.
- First we take the slope of the given line and find it's reciprocal.

$$y = \frac{\%v\{m1\}}{\%v\{m2\}} x + \%v\{a\}$$

The reciprocal of  $\frac{\%v\{m1\}}{\%v\{m2\}}$  is  $\frac{\%v\{m2\}}{\%v\{m1\}}$

- Next we take the opposite of the reciprocal value.

The opposite of  $\frac{\%v\{m2\}}{\%v\{m1\}}$  is  $\frac{-\%v\{m2\}}{\%v\{m1\}}$

- Finally, we take our new slope and form a new equation with a y-intercept of  $\%v\{b\}$ .

$$y = \frac{-\%v\{m2\}}{\%v\{m1\}} x + \%v\{b\}$$

This is the equation for the line perpendicular to the starting equation and having a y-intercept of  $\{b\}$ .

Type:  $y = (-m)x + b$

**2) Assistent #90167 "90167 - 57337 - Create Perpendicular Line"**

Here is the equation of a line.

$$y = \frac{3}{7}x + 4$$

Find the equation for the line that is perpendicular to this line and has a y-intercept of 1.

Give your answer in slope-intercept form.  $y = \underline{\hspace{2cm}}$

**Algebra:**

✓  $-2.3333333333333333x + 1$

**Hints:**

- Linear equations can be written in this form where m is the slope and b is the y-intercept.

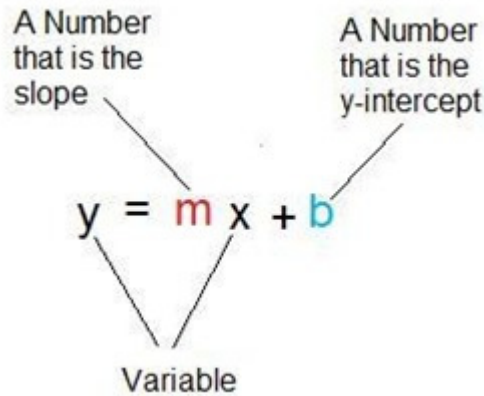

- Lines that are perpendicular will have reciprocal and opposite slopes.
- First we take the slope of the given line and find it's reciprocal.

$$y = \frac{3}{7}x + 4$$

The reciprocal of  $\frac{3}{7}$  is  $\frac{7}{3}$

- Next we take the opposite of the reciprocal value.

The opposite of  $\frac{7}{3}$  is  $-\frac{7}{3}$

- Finally, we take our new slope and form a new equation with a y-intercept of 1.

$$y = \frac{-7}{3}x + 1$$

This is the equation for the line perpendicular to the starting equation and having a y-intercept of 1.  
Type:  $y = (-7/3)x+1$

### 3) Assisment #73665 "73665 - 57337 - Create Perpendicular Line"

Here is the equation of a line.

$$y = \frac{\%v\{m1\}}{\%v\{m2\}}x + \%v\{a\}$$

Find the equation for the line that is perpendicular to this line and has a y-intercept of  $\%v\{b\}$ .

Give your answer in slope-intercept form.  $y = \underline{\hspace{2cm}}$

**Algebra:**

✓  $\%v\{-m2/m1\}x + \%v\{b\}$

**Hints:**

- Linear equations can be written in this form where m is the slope and b is the y-intercept.

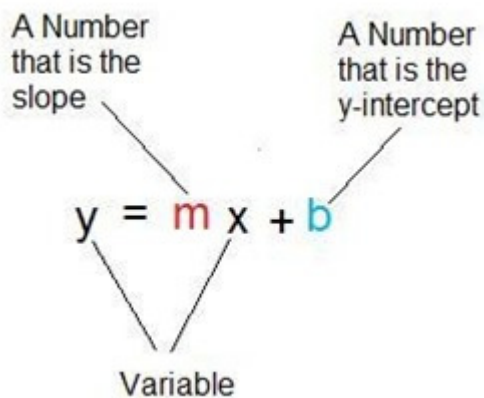

- Lines that are perpendicular will have reciprocal and opposite slopes.
- First we take the slope of the given line and find it's reciprocal.

$$y = \frac{\%v\{m1\}}{\%v\{m2\}}x + \%v\{a\}$$

The reciprocal of  $\frac{\%v\{m1\}}{\%v\{m2\}}$  is  $\frac{\%v\{-m2\}}{\%v\{-m1\}}$

- Next we take the opposite of the reciprocal value.

The opposite of  $\frac{\%v\{-m2\}}{\%v\{-m1\}}$  is  $\frac{\%v\{m2\}}{\%v\{-m1\}}$



- Finally, we take our new slope and form a new equation with a y-intercept of  $\{b\}$ .

$$y = \frac{\{m2\}}{\{-m1\}} x + \{b\}$$

This is the equation for the line perpendicular to the starting equation and having a y-intercept of  $\{b\}$ .

Type:  $y = (\{m2\}/\{-m1\})x + \{b\}$

---

4) Assistent #90202 "90202 - 57337 - Create Perpendicular Line"

Here is the equation of a line.

$$y = \frac{-9}{2} x + 10$$

Find the equation for the line that is perpendicular to this line and has a y-intercept of 4.

Give your answer in slope-intercept form.  $y = \underline{\hspace{2cm}}$

**Algebra:**

✓  $0.2222222222222222x + 4$

**Hints:**

- Linear equations can be written in this form where m is the slope and b is the y-intercept.

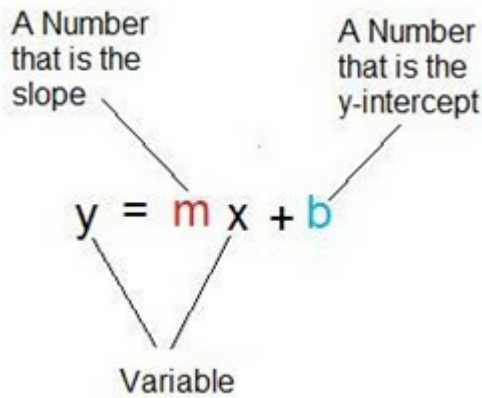

- Lines that are perpendicular will have reciprocal and opposite slopes.
- First we take the slope of the given line and find it's reciprocal.

$$y = \frac{-9}{2} x + 10$$

The reciprocal of  $\frac{-9}{2}$  is  $\frac{-2}{9}$

- Next we take the opposite of the reciprocal value.

The opposite of  $-\frac{2}{9}$  is  $\frac{2}{9}$

- Finally, we take our new slope and form a new equation with a y-intercept of 4.

$$y = \frac{2}{9}x + 4$$

This is the equation for the line perpendicular to the starting equation and having a y-intercept of 4.  
Type:  $y = (2/9)x+4$

### 5) Assisment #74969 "74969 - 57337 - Create Perpendicular Line"

Here is the equation of a line.

$$y = m x + a$$

Find the equation for the line that is perpendicular to this line and has a y-intercept of  $b$ .

Give your answer in slope-intercept form.  $y = \underline{\hspace{2cm}}$

**Algebra:**

✓  $y = -\frac{1}{m}x + b$

**Hints:**

- Linear equations can be written in this form where  $m$  is the slope and  $b$  is the y-intercept.

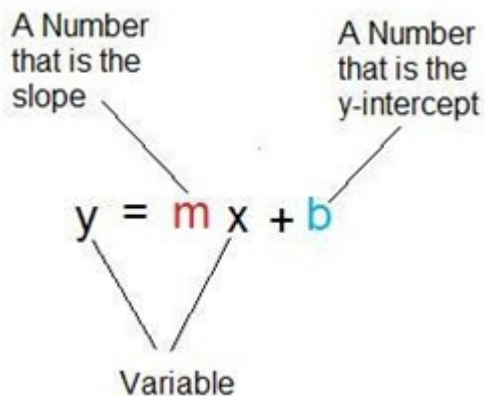

- Lines that are perpendicular will have reciprocal and opposite slopes.
- First we take the slope of the given line and find it's reciprocal.

$$y = m x + a$$

The reciprocal of  $m$  is  $\frac{1}{m}$

- Next we take the opposite of the reciprocal value.

The opposite of  $\frac{1}{m}$  is  $-\frac{1}{m}$

- Finally, we take our new slope and form a new equation with a y-intercept of  $\%v\{b\}$ .

$$y = \frac{-1}{\%v\{m\}} x + \%v\{b\}$$

This is the equation for the line perpendicular to the starting equation and having a y-intercept of  $\%v\{b\}$ .

Type:  $y = (-1/\%v\{m\})x + \%v\{b\}$

#### 6) Assistentment #90222 "90222 - 57337 - Create Perpendicular Line"

Here is the equation of a line.

$$y = 7x + 10$$

Find the equation for the line that is perpendicular to this line and has a y-intercept of 8.

Give your answer in slope-intercept form.  $y = \underline{\hspace{2cm}}$

**Algebra:**

✓  $-0.142857142857143x + 8$

**Hints:**

- Linear equations can be written in this form where m is the slope and b is the y-intercept.

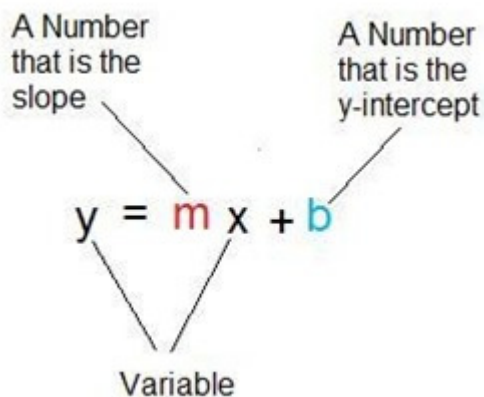

- Lines that are perpendicular will have reciprocal and opposite slopes.

- First we take the slope of the given line and find it's reciprocal.

$$y = 7 + 10$$

The reciprocal of 7 is  $\frac{1}{7}$

- Next we take the opposite of the reciprocal value.

The opposite of  $\frac{1}{7}$  is  $-\frac{1}{7}$

- Finally, we take our new slope and form a new equation with a y-intercept of 8.

$$y = -\frac{1}{7} x + 8$$

This is the equation for the line perpendicular to the starting equation and having a y-intercept of 8.  
Type:  $y = (-1/7)x + 8$

7) Assisment #74970 "74970 - 57337 - Create Perpendicular Line"

Here is the equation of a line.

$$y = m x + a$$

Find the equation for the line that is perpendicular to this line and has a y-intercept of  $b$ .

Give your answer in slope-intercept form.  $y = \underline{\hspace{2cm}}$

**Algebra:**

✓  $y = -1/m x + b$

**Hints:**

- Linear equations can be written in this form where  $m$  is the slope and  $b$  is the y-intercept.

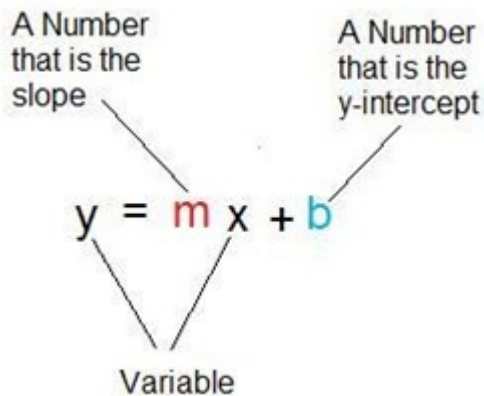

- Lines that are perpendicular will have reciprocal and opposite slopes.
- First we take the slope of the given line and find it's reciprocal.

$$y = m x + a$$

The reciprocal of  $m$  is  $\frac{-1}{m}$

- Next we take the opposite of the reciprocal value.

The opposite of  $\frac{-1}{m}$  is  $\frac{1}{m}$

- Finally, we take our new slope and form a new equation with a y-intercept of  $b$ .

$$y = \frac{1}{m} x + b$$

This is the equation for the line perpendicular to the starting equation and having a y-intercept of  $b$

{b}.

Type:  $y = (1/m)x + b$

---

**8) Assistent #90142 "90142 - 57337 - Create Perpendicular Line"**

Here is the equation of a line.

$$y = -9x + 6$$

Find the equation for the line that is perpendicular to this line and has a y-intercept of 11.

Give your answer in slope-intercept form.  $y = \underline{\hspace{2cm}}$

**Algebra:**

✓  $0.1111111111111111x + 11$

**Hints:**

- Linear equations can be written in this form where m is the slope and b is the y-intercept.

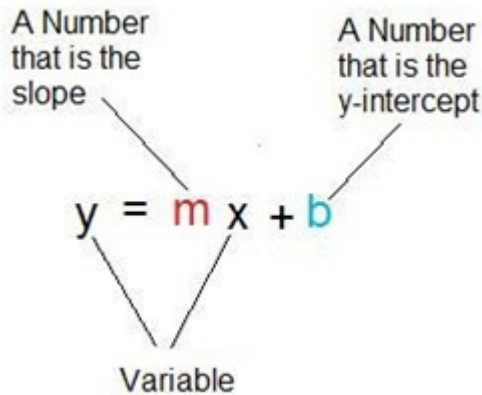

- Lines that are perpendicular will have reciprocal and opposite slopes.

- First we take the slope of the given line and find it's reciprocal.

$$y = -9x + 6$$

The reciprocal of  $-9$  is  $-\frac{1}{9}$

- Next we take the opposite of the reciprocal value.

The opposite of  $-\frac{1}{9}$  is  $\frac{1}{9}$

- Finally, we take our new slope and form a new equation with a y-intercept of 11.

$$y = \frac{1}{9}x + 11$$

This is the equation for the line perpendicular to the starting equation and having a y-intercept of 11.

Type:  $y = (1/9)x + 11$

---

9) Assistent #78129 "78129 - 57337 - Create Perpendicular Line"

Here is the equation of a line.

$$y = \frac{\%v\{m1\}}{\%v\{m2\}} x + \%v\{a\}$$

Find the equation for the line that is perpendicular to this line and has a y-intercept of  $\%v\{b\}$ .

Give your answer in slope-intercept form.  $y = \underline{\hspace{2cm}}$

**Algebra:**

✓  $\%v\{-m2\}x + \%v\{b\}$

**Hints:**

- Linear equations can be written in this form where m is the slope and b is the y-intercept.

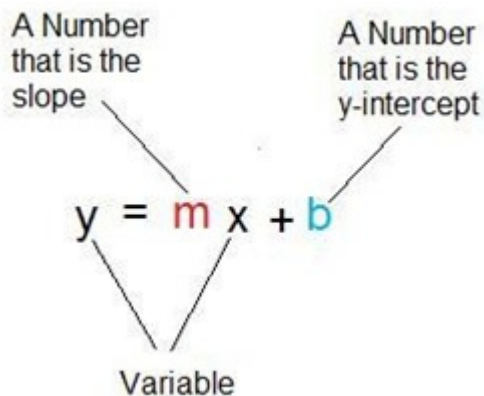

- Lines that are perpendicular will have reciprocal and opposite slopes.
- First we take the slope of the given line and find it's reciprocal.

$$y = \frac{\%v\{m1\}}{\%v\{m2\}} x + \%v\{a\}$$

The reciprocal of  $\frac{\%v\{m1\}}{\%v\{m2\}}$  is  $\%v\{m2\}$

- Next we take the opposite of the reciprocal value.

The opposite of  $\%v\{m2\}$  is  $-\%v\{m2\}$

- Finally, we take our new slope and form a new equation with a y-intercept of  $\%v\{b\}$ .

$$y = -\%v\{m2\}x + \%v\{b\}$$

This is the equation for the line perpendicular to the starting equation and having a y-intercept of  $\%v\{b\}$ .

Type:  $y = \%v\{-m2\}x + \%v\{b\}$

---

10) Assistent #90182 "90182 - 57337 - Create Perpendicular Line"

Here is the equation of a line.

$$y = \frac{1}{12}x + 10$$

Find the equation for the line that is perpendicular to this line and has a y-intercept of 4.

Give your answer in slope-intercept form.  $y = \underline{\hspace{2cm}}$

**Algebra:**

✓  $-12x+4$

**Hints:**

- Linear equations can be written in this form where m is the slope and b is the y-intercept.

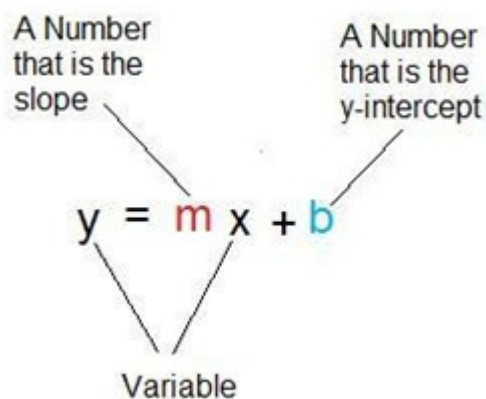

- Lines that are perpendicular will have reciprocal and opposite slopes.
- First we take the slope of the given line and find it's reciprocal.

$$y = \frac{1}{12}x + 10$$

The reciprocal of  $\frac{1}{12}$  is 12

- Next we take the opposite of the reciprocal value.

The opposite of 12 is -12

- Finally, we take our new slope and form a new equation with a y-intercept of 4.

$$y = -12x + 4$$

This is the equation for the line perpendicular to the starting equation and having a y-intercept of 4.  
Type:  $y = -12x+4$

---

Skill	Class
Write Linear Equation from Ordered Pairs	9th

Mastery Problem Set #10597	Number of Templates 6
Number to Master 5	Number of Attempts 10

## Templates:

Write a linear equation for the line going through the points (-6, 29) and (-8, 9)

Write your equation in the form  $y = \underline{\hspace{2cm}}$

[Comment on this question](#)

[Show me hint 1 of 5](#)

*Type your answer below (mathematical expression):*

[Submit Answer](#)

- 69710
  - Slope is random between 1 and 15
  - Y-intercept is random between -160 and 160
  - Point values of the second point are random between -10 and 10
  - X values of the first point are random between -20 and 20
  - Y values of the first point are random between -160 and 160
  - All values are integers
- 89334
  - Slope is random between -15 and -1
  - Otherwise identical to 69710



Write a linear equation in the form "y = \_\_\_\_\_" using the following information about the equation:

X-intercept of the equation: 3

Y-intercept of the equation: 9

[Comment on this question](#)

Show me hint 1 of 4

Type your answer below (mathematical expression):

Submit Answer

- 69714
  - X-intercept is random between 1 and 10
  - Y-intercept is random between 1 and 10
- 89335
  - X-intercept is random between -10 and -1
  - Y-intercept is random between -10 and -1
- 89336
  - X-intercept is random between 1 and 10
  - Y-intercept is random between -10 and -1
- 89337
  - X-intercept is random between -10 and 1
  - Y-intercept is random between 1 and 10

Template by: Christopher Kevorkian

**Problem Set "Write Linear Equation from Ordered Pairs - Printout"** id:[11065]

**1) Assistent #69710 "69710 - Write Linear Equation from Ordered Pairs"**

Write a linear equation for the line going through the points  $(x_1, y_1)$  and  $(x_2, y_2)$

Write your equation in the form  $y = \underline{\hspace{2cm}}$

**Algebra:**

✓  $mx + y_2 - m \cdot x_2$

**Hints:**

- Linear equations can be written in this form where  $m$  is the slope and  $b$  is the y-intercept.

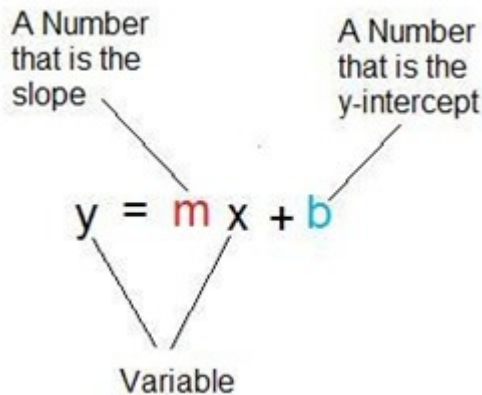

- We are given two points on the line, so we can use the following equation to find the the slope.

$$m = \text{slope} = \frac{\text{rise}}{\text{run}} = \frac{y_1 - y_2}{x_1 - x_2}$$

Substituting in the two points  $(x_1, y_1)$  and  $(x_2, y_2)$  gives the slope:

$$m = \frac{y_1 - y_2}{x_1 - x_2} = \frac{y_1 - y_2}{x_1 - x_2} = m$$

- We can find  $b$  by substituting in  $m$  and the point  $(x_1, y_1)$ .

$$y = mx + b$$

$$y_1 = m \cdot x_1 + b$$

Now solve for  $b$  and write the final equation.

- Now we will solve for  $b$ .  
 $y_1 = m \cdot x_1 + b$   
 $y_1 = m \cdot x_1 + b$   
 $y_1 - m \cdot x_1 = b$

$$y - m \cdot x_1 = b$$

$$b = y_1 - m \cdot x_1$$

- Now substitute the values of  $m$  of  $b$  into the equation. This is the equation of the line going through the points  $(x_1, y_1)$  and  $(x_2, y_2)$

$$y = m \cdot x + y_1 - m \cdot x_1$$

Type in:  $m \cdot x + y_1 - m \cdot x_1$

## 2) Assisment #89958 "89958 - 69710 - Write Linear Equation from Ordered Pairs"

Write a linear equation for the line going through the points  $(-2, -87)$  and  $(8, -7)$

Write your equation in the form  $y = \underline{\hspace{2cm}}$

**Algebra:**

✓  $8x + -71$

**Hints:**

- Linear equations can be written in this form where  $m$  is the slope and  $b$  is the y-intercept.

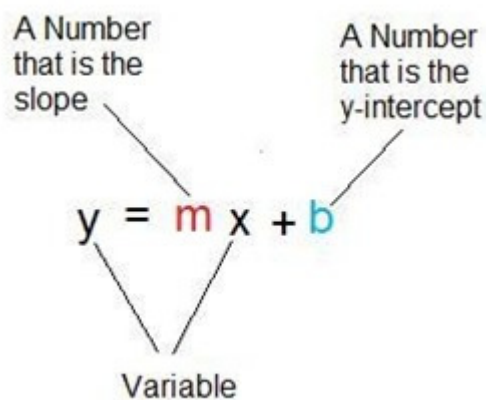

- We are given two points on the line, so we can use the following equation to find the the slope.

$$m = \text{slope} = \frac{\text{rise}}{\text{run}} = \frac{y_1 - y_2}{x_1 - x_2}$$

Substituting in the two points  $(-2, -87)$  and  $(8, -7)$  gives the slope:

$$m = \frac{-87 - -7}{-2 - 8} = \frac{-80}{-10} = 8$$

- We can find  $b$  by substituting in  $m$  and the point  $(-2, -87)$ .

$$y = mx + b$$

$$-87 = 8 \cdot -2 + b$$

Now solve for  $b$  and write the final equation.

- Now we will solve for  $b$ .

$$-87 = 8 \cdot -2 + b$$

$$-87 = -16 + b$$

$$-87 - -16 = b$$

$$-71 = b$$

$$b = -71$$

- Now substitute the values of  $m$  of  $b$  into the equation. This is the equation of the line going through the points  $(-2, -87)$  and  $(8, -7)$

$$y = 8x + -71$$

Type in:  $8x+-71$

### 3) Assistent #89334 "89334 - 69710 - Write Linear Equation from Ordered Pairs"

Write a linear equation for the line going through the points  $(x_1, y_1)$  and  $(x_2, y_2)$

Write your equation in the form  $y = \underline{\hspace{2cm}}$

**Algebra:**

✓  $y = mx + y_2 - m \cdot x_2$

**Hints:**

- Linear equations can be written in this form where  $m$  is the slope and  $b$  is the y-intercept.

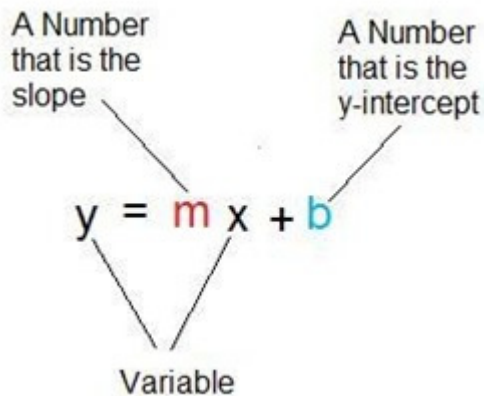

- We are given two points on the line, so we can use the following equation to find the the slope.

$$m = \text{slope} = \frac{\text{rise}}{\text{run}} = \frac{y_1 - y_2}{x_1 - x_2}$$

Substituting in the two points  $(x_1, y_1)$  and  $(x_2, y_2)$  gives the slope:

$$m = \frac{y_1 - y_2}{x_1 - x_2} = \frac{y_1 - y_2}{x_1 - x_2} = m$$

$$\frac{y_1 - y_2}{x_1 - x_2}$$

- We can find  $b$  by substituting in  $m$  and the point  $(x_1, y_1)$ .

$$y = mx + b$$

$$y_1 = m x_1 + b$$

Now solve for  $b$  and write the final equation.

- Now we will solve for  $b$ .

$$y_1 = m x_1 + b$$

$$y_1 = m x_1 + b$$

$$y_1 - m x_1 = b$$

$$b = y_1 - m x_1$$

$$b = y_1 - m x_1$$

- Now substitute the values of  $m$  of  $b$  into the equation. This is the equation of the line going through the points  $(x_1, y_1)$  and  $(x_2, y_2)$

$$y = m x + y_1 - m x_1$$

Type in:  $m x + y_1 - m x_1$

#### 4) Assistent #89993 "89993 - 69710 - Write Linear Equation from Ordered Pairs"

Write a linear equation for the line going through the points  $(16, -88)$  and  $(6, -8)$

Write your equation in the form  $y = \underline{\hspace{2cm}}$

**Algebra:**

✓  $-8x + 40$

**Hints:**

- Linear equations can be written in this form where  $m$  is the slope and  $b$  is the y-intercept.

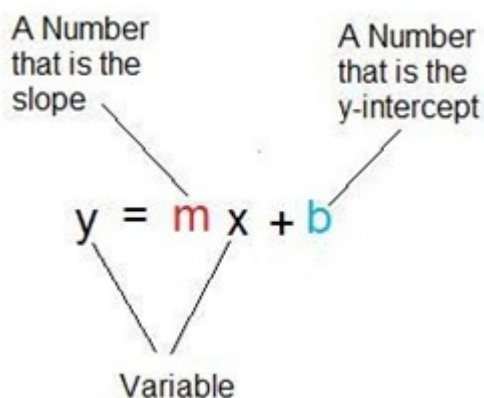

- We are given two points on the line, so we can use the following equation to find the the slope.

$$m = \text{slope} = \frac{\text{rise}}{\text{run}} = \frac{y_1 - y_2}{x_1 - x_2}$$

Substituting in the two points (16, -88) and (6, -8) gives the slope:

$$m = \frac{-88 - -8}{16 - 6} = \frac{-80}{10} = -8$$

- We can find  $b$  by substituting in  $m$  and the point (16, -88).

$$y = mx + b$$

$$-88 = -8*16 + b$$

Now solve for  $b$  and write the final equation.

- Now we will solve for  $b$ .

$$-88 = -8*16 + b$$

$$-88 = -128 + b$$

$$-88 - -128 = b$$

$$40 = b$$

$$b = 40$$

- Now substitute the values of  $m$  of  $b$  into the equation. This is the equation of the line going through the points (16, -88) and (6, -8)

$$y = -8x + 40$$

Type in: -8x+40

##### 5) Assistent #69714 "69714 - Write Linear Equation from X and Y Intercepts"

Write a linear equation in the form "y = \_\_\_\_\_" using the following information about the equation:

X-intercept of the equation:  $\%v\{xint\}$

Y-intercept of the equation:  $\%v\{yint\}$

**Algebra:**

✓  $\%v\{slope\}x + \%v\{yint\}$

**Hints:**

- Linear equations can be written in this form where  $m$  is the slope and  $b$  is the  $y$ -intercept.

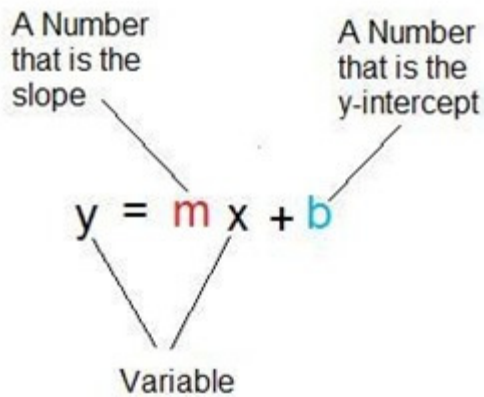

- The x and y intercepts give us the two points  $(x_{int}, 0)$  and  $(0, y_{int})$  on the line.
- We know that  $b = y_{int}$  because the y-intercept is  $y_{int}$

We can use the two points  $(x_{int}, 0)$  and  $(0, y_{int})$  along with the following equation to find the slope.

$$m = \text{slope} = \frac{\text{rise}}{\text{run}} = \frac{y_1 - y_2}{x_1 - x_2}$$

Substitution:

$$m = \frac{0 - y_{int}}{x_{int} - 0} = \frac{-y_{int}}{x_{int}}$$

- Now substitute the values of  $m$  of  $b$  into the equation. This is the equation of the line with x-intercept =  $x_{int}$  and y-intercept =  $y_{int}$ :

$$y = \frac{-y_{int}}{x_{int}}x + y_{int}$$

Type in:  $(-y_{int}/x_{int})x + y_{int}$

#### 6) Assistent #89983 "89983 - Write Linear Equation from X and Y Intercepts"

Write a linear equation in the form "y = \_\_\_\_\_" using the following information about the equation:

X-intercept of the equation: 9

Y-intercept of the equation: 2

**Algebra:**

✓  $-0.2222222222222222x+2$

**Hints:**

- Linear equations can be written in this form where **m** is the slope and **b** is the **y-intercept**.

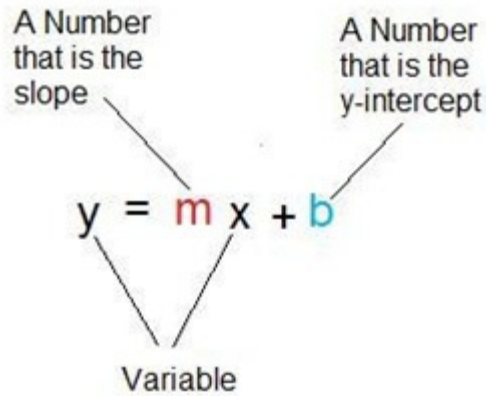

- The  $x$  and  $y$  intercepts give us the two points  $(9, 0)$  and  $(0, 2)$  on the line.
- We know that  $b = 2$  because the  $y$ -intercept is  $2$

We can use the two points  $(9, 0)$  and  $(0, 2)$  along with the following equation to find the the slope.

$$m = \text{slope} = \frac{\text{rise}}{\text{run}} = \frac{y_1 - y_2}{x_1 - x_2}$$

Substitution:

$$m = \frac{0 - 2}{9 - 0} = \frac{-2}{9}$$

- Now substitute the values of **m** of **b** into the equation. This is the equation of the line with  $x$ -intercept =  $9$  and  $y$ -intercept =  $2$ :

$$y = \frac{-2}{9}x + 2$$

Type in:  $(-2/9)x+2$



Write a linear equation in the form "y = \_\_\_\_\_" using the following information about the equation:

X-intercept of the equation:  $x_{int}$

Y-intercept of the equation:  $y_{int}$

**Algebra:**

✓  $\text{slope}x + \text{yint}$

**Hints:**

- Linear equations can be written in this form where **m** is the slope and **b** is the **y-intercept**.

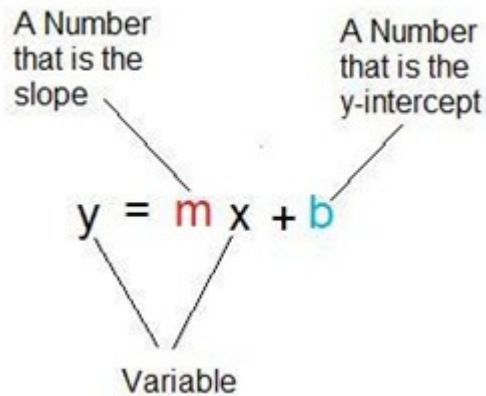

- The x and y intercepts give us the two points  $(x_{int}, 0)$  and  $(0, y_{int})$  on the line.
- We know that  $b = y_{int}$  because the y-intercept is  $y_{int}$

We can use the two points  $(x_{int}, 0)$  and  $(0, y_{int})$  along with the following equation to find the slope.

$$m = \text{slope} = \frac{\text{rise}}{\text{run}} = \frac{y_1 - y_2}{x_1 - x_2}$$

Substitution:

$$m = \frac{0 - y_{int}}{x_{int} - 0} = \frac{-y_{int}}{x_{int}}$$

- Now substitute the values of **m** of **b** into the equation. This is the equation of the line with x-intercept =  $x_{int}$  and y-intercept =  $y_{int}$ :

$$y = \frac{-y_{int}}{x_{int}}x + y_{int}$$

Type in:  $(\frac{-yint}{xint})x + yint$

---

**8) Assistent #90018 "90018 - Write Linear Equation from X and Y Intercepts"**

Write a linear equation in the form "y = \_\_\_\_\_" using the following information about the equation:

X-intercept of the equation: -9

Y-intercept of the equation: -3

**Algebra:**

✓  $-0.3333333333333333x + -3$

**Hints:**

- Linear equations can be written in this form where **m** is the slope and **b** is the **y-intercept**.

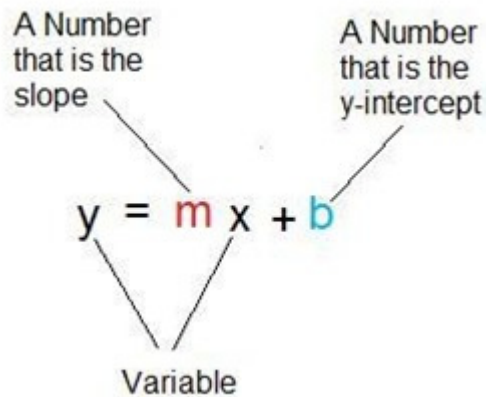

- The x and y intercepts give us the two points (-9, 0) and (0, -3) on the line.
- We know that  $b = -3$  because the y-intercept is -3

We can use the two points (-9, 0) and (0, -3) along with the following equation to find the the slope.

$$m = \text{slope} = \frac{\text{rise}}{\text{run}} = \frac{y1 - y2}{x1 - x2}$$

Substitution:

$$m = \frac{0 - -3}{-9 - 0} = \frac{3}{-9}$$

- Now substitute the values of  $m$  of  $b$  into the equation. This is the equation of the line with x-intercept = -9 and y-intercept = -3:

$$y = \frac{3}{-9}x - 3$$

Type in:  $(3/-9)x+-3$

### 9) Assistent #89336 "89336 - Write Linear Equation from X and Y Intercepts"

Write a linear equation in the form " $y = \underline{\hspace{2cm}}$ " using the following information about the equation:

X-intercept of the equation:  $\%v\{xint\}$

Y-intercept of the equation:  $\%v\{yint\}$

**Algebra:**

✓  $\%v\{slope\}x + \%v\{yint\}$

**Hints:**

- Linear equations can be written in this form where  $m$  is the slope and  $b$  is the  $y$ -intercept.

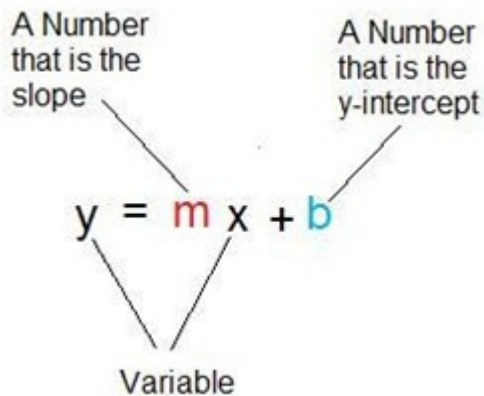

- The x and y intercepts give us the two points  $(\%v\{xint\}, 0)$  and  $(0, \%v\{yint\})$  on the line.
- We know that  $b = \%v\{yint\}$  because the y-intercept is  $\%v\{yint\}$

We can use the two points  $(\%v\{xint\}, 0)$  and  $(0, \%v\{yint\})$  along with the following equation to find the the slope.

$$m = \text{slope} = \frac{\text{rise}}{\text{run}} = \frac{y1 - y2}{x1 - x2}$$

Substitution:

$$m = \frac{0 - \%v\{yint\}}{\%v\{xint\} - 0} = \frac{\%v\{-yint\}}{\%v\{xint\}}$$

$$\frac{\%v\{xint\} - 0}{\%v\{xint\}}$$

- Now substitute the values of  $m$  of  $b$  into the equation. This is the equation of the line with x-intercept =  $\%v\{xint\}$  and y-intercept =  $\%v\{yint\}$ :

$$y = \frac{\%v\{-yint\}}{\%v\{xint\}} x + \%v\{yint\}$$

Type in:  $(\%v\{-yint\}/\%v\{xint\})x + \%v\{yint\}$

### 10) Assistent #90028 "90028 - Write Linear Equation from X and Y Intercepts"

Write a linear equation in the form "y = \_\_\_\_\_" using the following information about the equation:

X-intercept of the equation: 10

Y-intercept of the equation: -6

**Algebra:**

✓  $0.6x - 6$

**Hints:**

- Linear equations can be written in this form where  $m$  is the slope and  $b$  is the  $y$ -intercept.

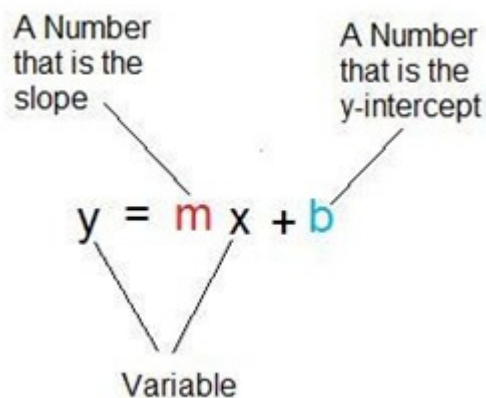

- The x and y intercepts give us the two points (10, 0) and (0, -6) on the line.
- We know that  $b = -6$  because the y-intercept is -6

We can use the two points (10, 0) and (0, -6) along with the following equation to find the the slope.

$$m = \text{slope} = \frac{\text{rise}}{\text{run}} = \frac{y1 - y2}{x1 - x2}$$

Substitution:

$$m = \frac{0 - -6}{10 - 0} = \frac{6}{10}$$

- Now substitute the values of  $m$  of  $b$  into the equation. This is the equation of the line with x-intercept = 10 and y-intercept = -6:

$$y = \frac{6}{10}x + -6$$

Type in:  $(6/10)x + -6$

### 11) Assisment #89337 "89337 - Write Linear Equation from X and Y Intercepts"

Write a linear equation in the form " $y = \underline{\hspace{2cm}}$ " using the following information about the equation:

X-intercept of the equation:  $\%v\{xint\}$

Y-intercept of the equation:  $\%v\{yint\}$

**Algebra:**

✓  $\%v\{slope\}x + \%v\{yint\}$

**Hints:**

- Linear equations can be written in this form where  $m$  is the slope and  $b$  is the  $y$ -intercept.

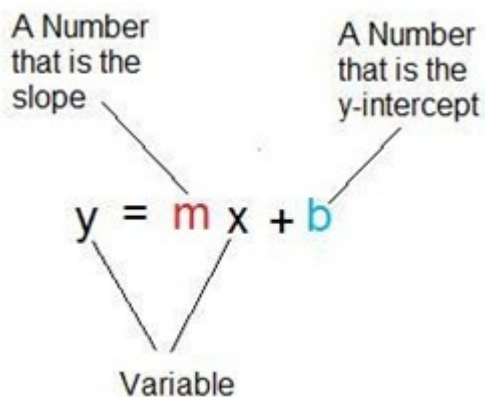

- The x and y intercepts give us the two points  $(\%v\{xint\}, 0)$  and  $(0, \%v\{yint\})$  on the line.
- We know that  $b = \%v\{yint\}$  because the y-intercept is  $\%v\{yint\}$

We can use the two points  $(x_1, 0)$  and  $(0, y_1)$  along with the following equation to find the slope.

$$m = \text{slope} = \frac{\text{rise}}{\text{run}} = \frac{y_1 - y_2}{x_1 - x_2}$$

Substitution:

$$m = \frac{0 - y_1}{x_1 - 0} = \frac{-y_1}{x_1}$$

- Now substitute the values of  $m$  and  $b$  into the equation. This is the equation of the line with x-intercept =  $x_1$  and y-intercept =  $y_1$ :

$$y = \frac{-y_1}{x_1} x + y_1$$

Type in:  $(-y_1/x_1)x + y_1$

---

### 12) Assisment #90038 "90038 - Write Linear Equation from X and Y Intercepts"

Write a linear equation in the form "y = \_\_\_\_\_" using the following information about the equation:

X-intercept of the equation: -2

Y-intercept of the equation: 7

**Algebra:**

✓ 3.5x+7

**Hints:**

- Linear equations can be written in this form where  $m$  is the slope and  $b$  is the y-intercept.

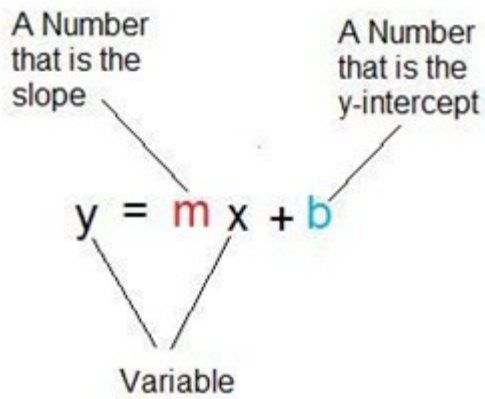

- The x and y intercepts give us the two points (-2, 0) and (0, 7) on the line.
- We know that  $b = 7$  because the y-intercept is 7

We can use the two points (-2, 0) and (0, 7) along with the following equation to find the the slope.

$$m = \text{slope} = \frac{\text{rise}}{\text{run}} = \frac{y_1 - y_2}{x_1 - x_2}$$

Substitution:

$$m = \frac{0 - 7}{-2 - 0} = \frac{-7}{-2}$$

- Now substitute the values of  $m$  of  $b$  into the equation. This is the equation of the line with x-intercept = -2 and y-intercept = 7:

$$y = \frac{-7}{-2}x + 7$$

Type in:  $(-7/-2)x+7$

---

Skill	Class
Write Linear Equation from Slope and Ordered Pair	9th

Mastery Problem Set #10446	Number of Templates 3
Number to Master 5	Number of Attempts 10

## Templates

Write a linear equation for the line with slope = 7 going through the point: (8, -1)

Write your equation in the form  $y = \underline{\hspace{2cm}}$

[Comment on this question](#)

[Show me hint 1 of 4](#)

Type your answer below (mathematical expression):

[Submit Answer](#)

- 68667
  - Slope is random between 1 and 10.
  - Point values are random between -10 and 10.
- 68668
  - Slope is random between -10 and -1.
  - Point values are random between -10 and 10.
- 68669
  - Slope is 0.
  - Point values are random between -10 and 10.

Template by: Christopher Kevorkian



## Problem Set "Write Linear Equation from Slope and Ordered Pair - Printout" id:[11064]

### 1) Assistent #68667 "68667 - Write Linear Equation from Slope and Ordered Pair"

Write a linear equation for the line with slope =  $\%v\{\text{slope}\}$  going through the point: ( $\%v\{xval\}$ ,  $\%v\{yval\}$ )

Write your equation in the form  $y = \underline{\hspace{2cm}}$

**Algebra:**

✓  $\%v\{\text{slope}\}x + \%v\{yval - \text{slope} * xval\}$

**Hints:**

- Linear equations can be written in this form where m is the slope and b is the y-intercept.

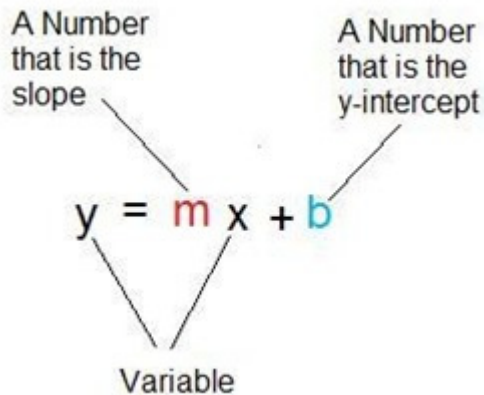

- We know that  $m = \%v\{\text{slope}\}$  because the slope is  $\%v\{\text{slope}\}$ , but we don't have the value of  $b$ .

We can find  $b$  by substituting in the slope =  $\%v\{\text{slope}\}$  and the point ( $\%v\{xval\}$ ,  $\%v\{yval\}$ ).

$$y = mx + b$$
$$\%v\{yval\} = \%v\{\text{slope}\} * \%v\{xval\} + b \quad \text{Substitute}$$

Now solve for  $b$  and write the final equation.

- Now we will solve for  $b$ .
$$\%v\{yval\} = \%v\{\text{slope}\} * \%v\{xval\} + b$$
$$\%v\{yval\} = \%v\{\text{slope} * xval\} + b$$
$$\%v\{yval\} - \%v\{\text{slope} * xval\} = b$$
$$b = \%v\{yval\} - \%v\{\text{slope} * xval\}$$
$$b = \%v\{yval - \text{slope} * xval\}$$

- We know that  $m = \%v\{\text{slope}\}$  and  $b = \%v\{yval - \text{slope} * xval\}$ .

$y = \%v\{\text{slope}\}x + \%v\{yval - \text{slope} * xval\}$  is the equation with slope  $\%v\{\text{slope}\}$  and goes through ( $\%v\{xval\}$ ,  $\%v\{yval\}$ )

Type in  $\%v\{\text{slope}\}x + \%v\{yval - \text{slope} * xval\}$

---

### 2) Assistent #89442 "89442 - Write Linear Equation from Slope and Ordered Pair"

Write a linear equation for the line with slope = 9 going through the point: (3, -4)

Write your equation in the form  $y = \underline{\hspace{2cm}}$

**Algebra:**

✓  $9x + -31$

**Hints:**

- Linear equations can be written in this form where  $m$  is the slope and  $b$  is the  $y$ -intercept.

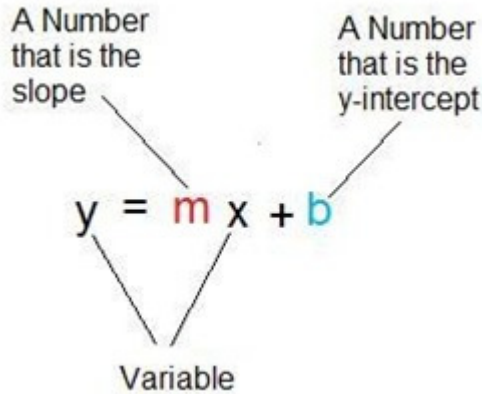

- We know that  $m = 9$  because the slope is 9, but we don't have the value of  $b$ .

We can find  $b$  by substituting in the slope = 9 and the point (3, -4).

$$\begin{aligned} y &= mx + b \\ -4 &= 9*3 + b \end{aligned} \quad \text{Substitute}$$

Now solve for  $b$  and write the final equation.

- Now we will solve for  $b$ .

$$\begin{aligned} -4 &= 9*3 + b \\ -4 &= 27 + b \\ -4 - 27 &= b \\ b &= -4 - 27 \\ b &= -31 \end{aligned}$$

- We know that  $m = 9$  and  $b = -31$ .

$y = 9x + -31$  is the equation with slope 9 and goes through (3, -4)

Type in  $9x + -31$

### 3) Assistentment #68668 "68668 - Write Linear Equation from Slope and Ordered Pair"

Write a linear equation for the line with slope =  $\%v\{\text{slope}\}$  going through the point: ( $\%v\{xval\}$ ,  $\%v\{yval\}$ )

Write your equation in the form  $y = \underline{\hspace{2cm}}$

**Algebra:**

✓  $\%v\{\text{slope}\}x + \%v\{yval - \text{slope} * xval\}$

**Hints:**

- Point-slope form is as follows:  
 $y - y_1 = m(x - x_1)$
- Here is how the data given in the problem relates to point slope form:  
 $m = \text{slope} = \%$  $\{ \text{slope} \}$   
 $(x_1, y_1) = (\%$  $\{ \text{xval} \}, \%$  $\{ \text{yval} \})$
- Plugging the values into the point-slope form equation gives the following equation:  
 $y - \%$  $\{ \text{yval} \} = \%$  $\{ \text{slope} \}(x - \%$  $\{ \text{xval} \})$   
All that remains is to put the equation in the form  $y = \underline{\hspace{2cm}}$
- Let's simplify and solve for y. The answer isn't required to be simplified, but it is a good practice to follow.

$$y - \%$$
 $\{ \text{yval} \} = \%$  $\{ \text{slope} \}(x - \%$  $\{ \text{xval} \})$ 

$$y - \%$$
 $\{ \text{yval} \} = \%$  $\{ \text{slope} \}x - \%$  $\{ \text{slope} \} \cdot \%$  $\{ \text{xval} \}$ 

$$y = \%$$
 $\{ \text{slope} \}x - \%$  $\{ \text{slope} \} \cdot \%$  $\{ \text{xval} \} + \%$  $\{ \text{yval} \}$ 

$$y = \%$$
 $\{ \text{slope} \}x + \%$  $\{ \text{yval} - \text{slope} \cdot \text{xval} \}$

The equation of the line with slope =  $\%$  $\{ \text{slope} \}$  going through the point:  $(\%$  $\{ \text{xval} \}, \%$  $\{ \text{yval} \})$  is:  
 $y = \%$  $\{ \text{slope} \}x + \%$  $\{ \text{yval} - \text{slope} \cdot \text{xval} \}$

Type:  $\%$  $\{ \text{slope} \}x + \%$  $\{ \text{yval} - \text{slope} \cdot \text{xval} \}$

**4) Assisment #89460 "89460 - Write Linear Equation from Slope and Ordered Pair"**

Write a linear equation for the line with slope = -2 going through the point: (10, -9)

Write your equation in the form  $y = \underline{\hspace{2cm}}$

**Algebra:**

  $-2x+11$

**Hints:**

- Point-slope form is as follows:  
 $y - y_1 = m(x - x_1)$
- Here is how the data given in the problem relates to point slope form:  
 $m = \text{slope} = -2$   
 $(x_1, y_1) = (10, -9)$
- Plugging the values into the point-slope form equation gives the following equation:  
 $y - -9 = -2(x - 10)$   
All that remains is to put the equation in the form  $y = \underline{\hspace{2cm}}$
- Let's simplify and solve for y. The answer isn't required to be simplified, but it is a good practice to follow.

$$y - -9 = -2(x - 10)$$

$$y - -9 = -2x - -20$$

$$y = -2x - -20 + -9$$

$$y = -2x + 11$$

The equation of the line with slope = -2 going through the point: (10, -9) is:  
 $y = -2x + 11$

Type:  $-2x + 11$

---

5) Assisment #68669 "68669 - Write Linear Equation from Slope and Ordered Pair"

Write a linear equation for the line with slope = 0 going through the point: ( $\%v\{xval\}$ ,  $\%v\{yval\}$ )

Write your equation in the form  $y = \underline{\hspace{2cm}}$

**Algebra:**

✓  $\%v\{yval\}$

**Hints:**

- When the slope of a line is 0, the line is perfectly horizontal. This means that no matter how far you move along the x-axis, the value of y stays the same.
- We know the line passes through the point ( $\%v\{xval\}$ ,  $\%v\{yval\}$ ), and the value of y at that point is  $\%v\{yval\}$ .
- Since y always stays the same for this line (because it is horizontal) and at one point along the line the value of y is  $\%v\{yval\}$ , the equation of this line is  $y = \%v\{yval\}$ .

Type:  $\%v\{yval\}$

---

6) Assisment #89481 "89481 - Write Linear Equation from Slope and Ordered Pair"

Write a linear equation for the line with slope = 0 going through the point: (8, 5)

Write your equation in the form  $y = \underline{\hspace{2cm}}$

**Algebra:**

✓ 5

**Hints:**

- When the slope of a line is 0, the line is perfectly horizontal. This means that no matter how far you move along the x-axis, the value of y stays the same.
- We know the line passes through the point (8, 5), and the value of y at that point is 5.
- Since y always stays the same for this line (because it is horizontal) and at one point along the line the value of y is 5, the equation of this line is  $y = 5$ .

Type: 5

---

# Algebra

Skill	Class
Solving Systems of Equations	Algebra I

## THE MASTERY SET

Mastery Problem Set <input type="text" value="#8926"/>	Number of Templates <input type="text" value="3"/>
Number to Master <input type="text" value="3 in-a-row"/>	Number of Attempts <input type="text" value="10 First Day, 10 Subsequent Days"/>

## Templates

60010

Debra was given a system of equations to solve and decided to graph the two equations. What is the value of  $x$  in the solution of this system of equations?

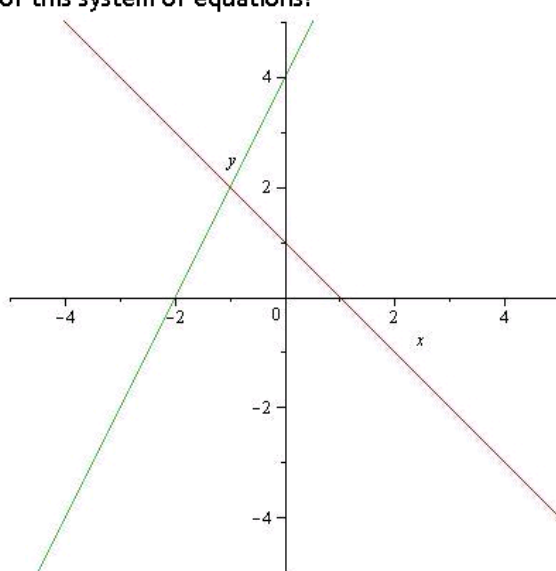

[Comment on this question](#)

Show me hint 1 of 3

Type your answer below (mathematical expression):

Submit Answer

# Algebra

What is the value of  $y$  in the solution of this system of equations?

[Comment on this question](#)

Show me hint 1 of 3

Type your answer below (mathematical expression):

Submit Answer

- Selects 1 of 25 different graphs
- Answers are integers between -3 and 3 for  $x$  and  $y$  values

59998

Solve the following system of equations using substitution.

$$-2y = 2x - 2$$

$$4y = 4x - 16$$

What is the value of  $x$ ?  
(Enter as a fraction)

[Comment on this question](#)

Show me hint 1 of 4

Type your answer below (mathematical expression):

Submit Answer

- $y$  coefficient is an integer between -5 and 5
- All numbers evenly divisible by their respective  $y$  coefficient
- Other numbers range between -25 and 25
- Cannot generate unsolvable or parallel equations

# Algebra

60008

Solve the following system of equations using linear combination.

$$6y + 2x = 9$$

$$9y + 9x = -7$$

What is the value of x?  
(Enter as a fraction)

[Comment on this question](#)

Show me hint 1 of 2

Type your answer below (mathematical expression):

Submit Answer

- All numbers are integers between -9 and 9, excluding zero
- Cannot generate unsolvable or parallel equations

# Algebra

Level 1 Graphing	Class <b>Algebra I</b>
---------------------	---------------------------

Mastery Problem Set <input type="text" value="#8928"/>	Number of Templates <input type="text" value="1"/>
Number to Master <input type="text" value="3 in-a-row"/>	Number of Attempts <input type="text" value="10 First Day, 10 Subsequent Days"/>

## Templates

60010

Debra was given a system of equations to solve and decided to graph the two equations. What is the value of  $x$  in the solution of this system of equations?

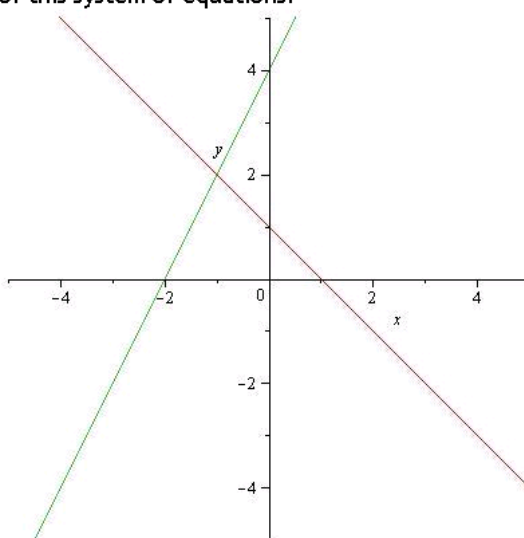

[Comment on this question](#)

Show me hint 1 of 3

Type your answer below (mathematical expression):

Submit Answer



# Algebra

What is the value of  $y$  in the solution of this system of equations?

[Comment on this question](#)

Show me hint 1 of 3

Type your answer below (mathematical expression):

Submit Answer

- Selects 1 of 25 different graphs
- Answers are integers between -3 and 3 for  $x$  and  $y$  values

# Algebra

Level 2 Substitution	Class <b>Algebra I</b>
-------------------------	---------------------------

Mastery Problem Set <input type="text" value="#8929"/>	Number of Templates <input type="text" value="1"/>
Number to Master <input type="text" value="3 in-a-row"/>	Number of Attempts <input type="text" value="10 First Day, 10 Subsequent Days"/>

## Templates

59998

Solve the following system of equations using substitution.

$$-2y = 2x - 2$$

$$4y = 4x - 16$$

What is the value of x?  
(Enter as a fraction)

[Comment on this question](#)

Show me hint 1 of 4

Type your answer below (mathematical expression):

Submit Answer

- Y coefficient is an integer between -5 and 5
- All numbers evenly divisible by their respective y coefficient
- Other numbers range between -25 and 25
- Cannot generate unsolvable or parallel equations

# Algebra

Level 3 Linear Combination	Class Algebra I
-------------------------------	--------------------

Mastery Problem Set #8930	Number of Templates 1
Number to Master 3 in-a-row	Number of Attempts 10 First Day, 10 Subsequent Days

## Templates

60008

Solve the following system of equations using linear combination.

$$6y + 2x = 9$$

$$9y + 9x = -7$$

What is the value of  $x$ ?  
(Enter as a fraction)

[Comment on this question](#)

Show me hint 1 of 2

Type your answer below (mathematical expression):

Submit Answer

- All numbers are integers between -9 and 9, excluding zero
- Cannot generate unsolvable or parallel equations

**Problem Set "Sequence #10915"** id:[10915]**1) Assistent #60010 "60010 - Systems of Equations - Graphing (Hints)"**

A) %v{name} was given a system of equations to solve and decided to graph the two equations. What is the value of x in the solution of this system of equations?

**Algebra:**

✓ %v{x}

✗ %v{y}

**Hints:**

- A graph is a picture of all the points where an equation is true. Any point that lies on a the **green** line satisfies the **green** equation. Any point on the **red** line satisfies the **red** equation.
- The only point where both equations are true is the **intersection**. This one point satisfies both equations. It is the **solution** to the system of equations. Find the value of x at this point.

- The lines intersect at the point  $(v\{x\}, v\{y\})$ .  
The  $x$  component of this point is  $v\{x\}$ : it is the value of  $x$  in the solution of the system of equations.

Please type  $v\{x\}$ .

**Hints:**

- There are no hints for this problem. The next hint will reveal the answer.
- The value of  $x$  in the solution to the system of equations is  $v\{x\}$ .

Please type  $v\{x\}$ .

**B)** What is the value of  $y$  in the solution of this system of equations?

**Algebra:**

✓  $v\{y\}$

✗  $v\{x\}$

**Hints:**

- A graph is a picture of all the points where an equation is true. Any point that lies on a the **green** line satisfies the **green** equation. Any point on the **red** line satisfies the **red** equation.
- The only point where both equations are true is the **intersection**. This one point satisfies both equations. It is the **solution** to the system of equations. Find the value of  $y$  at this point.

- The lines intersect at the point  $(x, y)$ .  
The  $y$  component of this point is  $y$ : it is the value of  $y$  in the solution of the system of equations.

Please type  $y$ .

**Hints:**

- There are no hints for this problem. The next hint will reveal the answer.
- The value of  $y$  in the solution to the system of equations is  $y$ .

Please type  $y$ .

---

**2) Assistment #69021 "69021 - 60010 - Systems of Equations - Graphing (Hints)"**

A) Debra was given a system of equations to solve and decided to graph the two equations. What is the value of  $x$  in the solution of this system of equations?

**Algebra:**

✓ -1

✗ 2

**Hints:**

- There are no hints for this problem. The next hint will reveal the answer.
- The value of  $x$  in the solution to the system of equations is -1.

Please type -1.

**Hints:**

- A graph is a picture of all the points where an equation is true. Any point that lies on a the green line satisfies the green equation. Any point on the red line satisfies the red equation.

- The only point where both equations are true is the **intersection**. This one point satisfies both equations. It is the **solution** to the system of equations. Find the value of  $x$  at this point.

- The lines intersect at the point  $(-1, 2)$ .  
The  $x$  component of this point is  $-1$ : it is the value of  $x$  in the solution of the system of equations.

Please type  $-1$ .

**B)** What is the value of  $y$  in the solution of this system of equations?

**Algebra:**

 2

  $-1$

**Hints:**

- A graph is a picture of all the points where an equation is true. Any point that lies on a the **green** line satisfies the **green** equation. Any point on the **red** line satisfies the **red** equation.
- The only point where both equations are true is the **intersection**. This one point satisfies both equations. It is the **solution** to the system of equations. Find the value of  $y$  at this point.

- The lines intersect at the point  $(-1, 2)$ .  
The  $y$  component of this point is  $2$ : it is the value of  $y$  in the solution of the system of equations.

Please type 2.

**Hints:**

- There are no hints for this problem. The next hint will reveal the answer.
- The value of  $y$  in the solution to the system of equations is  $2$ .

Please type 2.

**3) Assistment #59998 "59998 - Systems of Equations - Substitution (Hints)"**

Solve the following system of equations using substitution.

$$\begin{aligned} (sa=1) \text{ "" : "-" } \{ra=1\} y &= (sb=1) \text{ "" : "-" } \{rb=1\} x \\ (sc=1) \text{ "+" : "-" } \{rc\} & \\ (sd=1) \text{ "" : "-" } \{rd=1\} y &= (se=1) \text{ "" : "-" } \{re=1\} x \\ (sf=1) \text{ "+" : "-" } \{rf\} & \end{aligned}$$

What is the value of  $x$ ?

(Enter as a fraction)

**Algebra:**

✓  $\{q1\}$

✗  $\{q2\}$

**Hints:**

- The problem asks you to find the value of  $x$  using substitution.  
The first step is to solve one of the eqations for the other variable,  $y$ .

Here, we solve the first equation for  $y$  in terms of  $x$ .

$$\frac{(sa=1) \text{ "" : "-" } \{ra\} y}{(sa=1) \text{ "" : "-" } \{ra\}} = \frac{(sb=1) \text{ "" : "-" } \{rb\} x + (sc=1) \text{ "+" : "-" } \{rc\}}{(sa=1) \text{ "" : "-" } \{ra\}}$$

$$y = \frac{((sa * sb) = 1) \text{ "" : "-" } \{((rb / ra) = 1) \text{ "" : "(rb / ra)}\} x + ((sa * sc) = 1) \text{ "+" : "-" } \{rc / ra\}}{(sa * sb) = 1) \text{ "" : "-" } \{((rb / ra) = 1) \text{ "" : "(rb / ra)}\} x + ((sa * sc) = 1) \text{ "+" : "-" } \{rc / ra\}}$$



- The next step is to substitute the expression you found for **y** into the other equation.

Since we used the **first** equation to find

$$y = \frac{((s_a * s_b) - 1) * ((r_b / r_a) - 1)}{((s_a * s_c) - 1) * ((r_c / r_a) - 1)}$$

we substitute the expression  $\frac{((s_a * s_b) - 1) * ((r_b / r_a) - 1)}{((s_a * s_c) - 1) * ((r_c / r_a) - 1)}$  for **y** in the **second** equation.

$$((s_d - 1) * ((r_d - 1) * y)) = ((s_e - 1) * ((r_e - 1) * x)) * ((s_f - 1) * ((r_f - 1) * x))$$

$$\frac{((s_d - 1) * ((r_d - 1) * \frac{((s_a * s_b) - 1) * ((r_b / r_a) - 1)}{((s_a * s_c) - 1) * ((r_c / r_a) - 1)}))}{((s_d - 1) * ((r_d - 1) * \frac{((s_a * s_b) - 1) * ((r_b / r_a) - 1)}{((s_a * s_c) - 1) * ((r_c / r_a) - 1)}))} = \frac{((s_e - 1) * ((r_e - 1) * x)) * ((s_f - 1) * ((r_f - 1) * x))}{((s_e - 1) * ((r_e - 1) * x)) * ((s_f - 1) * ((r_f - 1) * x))}$$

- Now we have an equation with only one unknown variable, **x**.  
The last step is to solve this new equation for **x**.

$$\frac{((s_d - 1) * ((r_d - 1) * \frac{((s_a * s_b) - 1) * ((r_b / r_a) - 1)}{((s_a * s_c) - 1) * ((r_c / r_a) - 1)}))}{((s_d - 1) * ((r_d - 1) * \frac{((s_a * s_b) - 1) * ((r_b / r_a) - 1)}{((s_a * s_c) - 1) * ((r_c / r_a) - 1)}))} = \frac{((s_e - 1) * ((r_e - 1) * x)) * ((s_f - 1) * ((r_f - 1) * x))}{((s_e - 1) * ((r_e - 1) * x)) * ((s_f - 1) * ((r_f - 1) * x))}$$

$$\frac{((s_d - 1) * ((r_d - 1) * \frac{((s_a * s_b) - 1) * ((r_b / r_a) - 1)}{((s_a * s_c) - 1) * ((r_c / r_a) - 1)}))}{((s_d - 1) * ((r_d - 1) * \frac{((s_a * s_b) - 1) * ((r_b / r_a) - 1)}{((s_a * s_c) - 1) * ((r_c / r_a) - 1)}))} = \frac{((s_e - 1) * ((r_e - 1) * x)) * ((s_f - 1) * ((r_f - 1) * x))}{((s_e - 1) * ((r_e - 1) * x)) * ((s_f - 1) * ((r_f - 1) * x))}$$

$$\frac{((s_a * s_b) - 1) * ((r_b / r_a) - 1)}{((s_a * s_c) - 1) * ((r_c / r_a) - 1)} = \frac{((s_d * s_e) - 1) * ((r_e / r_d) - 1)}{((s_f * s_d) - 1) * ((r_f / r_d) - 1)}$$

$$\frac{((s_a * s_b) - 1) * ((r_b / r_a) - 1)}{((s_a * s_c) - 1) * ((r_c / r_a) - 1)} * \frac{((s_d * s_e) - 1) * ((r_e / r_d) - 1)}{((s_f * s_d) - 1) * ((r_f / r_d) - 1)} = \frac{((s_d * s_e) - 1) * ((r_e / r_d) - 1)}{((s_f * s_d) - 1) * ((r_f / r_d) - 1)}$$

$$\frac{((s_a * s_b) - 1) * ((r_b / r_a) - 1)}{((s_a * s_c) - 1) * ((r_c / r_a) - 1)} = \frac{((s_d * s_e) - 1) * ((r_e / r_d) - 1)}{((s_f * s_d) - 1) * ((r_f / r_d) - 1)}$$

$$\frac{((s_a * s_b) - 1) * ((r_b / r_a) - 1)}{((s_a * s_c) - 1) * ((r_c / r_a) - 1)} * \frac{((s_d * s_e) - 1) * ((r_e / r_d) - 1)}{((s_f * s_d) - 1) * ((r_f / r_d) - 1)} = \frac{((s_d * s_e) - 1) * ((r_e / r_d) - 1)}{((s_f * s_d) - 1) * ((r_f / r_d) - 1)}$$

$$((r_h * r_h) - 1) * ((r_h - 1) * x) = ((r_g * s_g) - 1) * ((r_h - 1) * x)$$

$$((r_h * r_h) - 1) * ((r_h - 1) * x) = ((r_h - 1) * x) * ((r_h - 1) * x)$$

$$\frac{r}{s} = \frac{r}{s} \cdot \frac{s}{s} = \frac{rs}{s^2}$$

$$\frac{r}{s} = \frac{r}{s} \cdot \frac{s}{s} = \frac{rs}{s^2}$$

- The value of  $x$  is  $\frac{r}{s}$ . Please type  $\frac{r}{s}$ .

**Hints:**

- There are no hints for this problem. The next hint will reveal the answer.
- The value of  $x$  is  $\frac{r}{s}$ . Please type  $\frac{r}{s}$ .

**4) Assistment #69037 "69037 - 59998 - Systems of Equations - Substitution (Hints)"**

Solve the following system of equations using substitution.

$$-4y = 12x - 16$$

$$-3y = 3x - 3$$

What is the value of  $x$ ?

(Enter as a fraction)

**Algebra:**

✓ 1.5

✗ -0.5

**Hints:**

- There are no hints for this problem. The next hint will reveal the answer.
- The value of  $x$  is  $\frac{3}{2}$ . Please type  $\frac{3}{2}$ .

**Hints:**

- The problem asks you to find the value of  $x$  using substitution. The first step is to solve one of the equations for the other variable,  $y$ .

Here, we solve the first equation for  $y$  in terms of  $x$ .

$$\frac{-4y}{-4} = \frac{12x - 16}{-4}$$

$$y = -3x + 4$$

- The next step is to substitute the expression you found for  $y$  into the other equation.

Since we used the **first** equation to find

$$y = -3x + 4$$

we substitute the expression  $-3x + 4$  for  $y$  in the **second** equation.

$$-3y = 3x - 3$$

$$-3(-3x + 4) = 3x - 3$$

- Now we have an equation with only one unknown variable,  $x$ .  
The last step is to solve this new equation for  $x$ .

$$-3(-3x + 4) = 3x - 3$$

$$\frac{-3(-3x + 4)}{-3} = \frac{3x - 3}{-3}$$

$$-3x + 4 = -x + 1$$

$$-3x + 4 - 4 = -x + 1 - 4$$

$$-3x = -x - 3$$

$$-3x + x = -x - 3 + x$$

$$-2x = -3$$

$$-2x / -2 = -3 / -2$$

$$x = 3 / 2$$

- The value of  $x$  is  $3 / 2$   
Please type  $3 / 2$

##### 5) Assistment #60008 "60008 - Systems of Equations - Linear Combination (Hints)"

Solve the following system of equations using linear combination.

$$\begin{aligned} & \%v\{((sa==1)? "" : "-")\}%v\{((ra==1)? "" : ra)\}y \%v\{((sb==1)? "+" : "-")\} \%v\{((rb==1)? "" : rb)\}x = \\ & \%v\{((sc==1)? "" : "-")\}%v\{rc\} \\ & \%v\{((sd==1)? "" : "-")\}%v\{((rd==1)? "" : rd)\}y \%v\{((se==1)? "+" : "-")\} \%v\{((re==1)? "" : re)\}x = \\ & \%v\{((sf==1)? "" : "-")\}%v\{rf\} \end{aligned}$$

What is the value of  $x$ ?  
(Enter as a fraction)

**Algebra:**

✓  $\%v\{q1\}$

✗  $\%v\{q2\}$

**Hints:**

- The problem asks you to find the value of **x** using linear combination.

We need to subtract one equation from the other in a way that makes any terms containing the variable **y** cancel out.

One way to do this is the multiply both sides of each equation by the **y** coefficient of the other equation.

$$\%v\{(sa * ra)\}y \%v\{((sb==1)? "+" : "-")\} \%v\{((rb==1)? "" : rb)\}x = \%v\{((sc==1)? "" : "-")\} \%v\{rc\}$$

$$\%v\{(sd * rd)\}y \%v\{((se==1)? "+" : "-")\} \%v\{((re==1)? "" : re)\}x = \%v\{((sf==1)? "" : "-")\} \%v\{rf\}$$

The **first equation** is multiplied by  $\%v\{(sd * rd)\}$ , which is the **y** coefficient of the **second equation**.  
 The **second equation** is multiplied by  $\%v\{(sa * ra)\}$ , which is the **y** coefficient of the **first equation**.

$$\%v\{(sd * rd)\} * (\%v\{((sa==1)? "" : "-")\} \%v\{((ra==1)? "" : ra)\}y \%v\{((sb==1)? "+" : "-")\} \%v\{((rb==1)? "" : rb)\}x) = \%v\{(sd * rd)\} * \%v\{((sc==1)? "" : "-")\} \%v\{rc\}$$

$$\%v\{(sa * ra)\} * (\%v\{((sd==1)? "" : "-")\} \%v\{((rd==1)? "" : rd)\}y \%v\{((se==1)? "+" : "-")\} \%v\{((re==1)? "" : re)\}x) = \%v\{(sa * ra)\} * \%v\{((sf==1)? "" : "-")\} \%v\{rf\}$$

$$\%v\{(((sa * sd) == 1)? "" : "-")\} \%v\{(((ra * rd) == 1)? "" : (ra * rd))\}y \%v\{(((sb * sd) == 1)? "+" : "-")\} \%v\{(((rb * rd) == 1)? "" : (rb * rd))\}x = \%v\{(((sc * sd) == 1)? "" : "-")\} \%v\{(rc * rd)\}$$

$$\%v\{(((sa * sd) == 1)? "" : "-")\} \%v\{(((ra * rd) == 1)? "" : (ra * rd))\}y \%v\{(((sa * se) == 1)? "+" : "-")\} \%v\{(((ra * re) == 1)? "" : (ra * re))\}x = \%v\{(((sa * sf) == 1)? "" : "-")\} \%v\{(rf * ra)\}$$

- Now subtract one equation from the other.

$$\%v\{(((sa * sd) == 1)? "" : "-")\} \%v\{(((ra * rd) == 1)? "" : (ra * rd))\}y \%v\{(((sb * sd) == 1)? "+" : "-")\} \%v\{(((rb * rd) == 1)? "" : (rb * rd))\}x = \%v\{(((sc * sd) == 1)? "" : "-")\} \%v\{(rc * rd)\}$$

$$\%v\{(((sa * sd) == 1)? "" : "-")\} \%v\{(((ra * rd) == 1)? "" : (ra * rd))\}y \%v\{(((sa * se) == 1)? "+" : "-")\} \%v\{(((ra * re) == 1)? "" : (ra * re))\}x = \%v\{(((sa * sf) == 1)? "" : "-")\} \%v\{(rf * ra)\}$$

$$\%v\{(((sa * sd) == 1)? "" : "-")\} \%v\{(((ra * rd) == 1)? "" : (ra * rd))\}y \%v\{(((sb * sd) == 1)? "+" : "-")\} \%v\{(((rb * rd) == 1)? "" : (rb * rd))\}x = \%v\{(((sc * sd) == 1)? "" : "-")\} \%v\{(rc * rd)\}$$

$$- \%v\{(((sa * se) == 1)? "+" : "-")\} \%v\{(((ra * re) == 1)? "" : (ra * re))\}x = \%v\{(((sa * sf) == 1)? "" : "-")\} \%v\{(rf * ra)\}$$

$$\%v\{((sg == 1) ? "" : "-")\} \%v\{(((rg * sg) == 1) ? "" : (sg * rg))\}x = \%v\{rh\}$$

*Notice how the terms containing the variable **y** cancel out.*

- Now we have an equation with only one unknown variable, **x**.  
 The last step is to solve this new equation for **x**.

$$\%v\{((sg == 1) ? "" : "-")\}\%v\{(((rg * sg) == 1) ? "" : (sg * rg))\}x = \%v\{rh\}$$

$$\%v\{((sg == 1) ? "" : "-")\}\%v\{(((rg * sg) == 1) ? "" : (sg * rg))\}\%v\{((rg == 1) ? "" : "x")\}\%v\{((rg == 1) ? "" : "/" / ")}\%v\{((rg == 1) ? "" : rg)\} = \%v\{((rg == 1) ? "" : rh)\}\%v\{((rg == 1) ? "" : "/" / ")}\%v\{((rg == 1) ? "" : rg)\}$$

$$\%v\{((rg == 1) ? "" : "x")\}\%v\{((rg == 1) ? "" : "=")\}\%v\{(((rg - 1) * (sg * sh - 1)) == 0) ? "" : "-")\}\%v\{((rg == 1) ? "" : (rh * sh))\}\%v\{((rg == 1) ? "" : "/" / ")}\%v\{((rg == 1) ? "" : (rg * sg))\}$$

The value of x is  $\%v\{(sg * rh)\} / \%v\{(rg * sg)\}$

Please type  $\%v\{(sg * rh)\} / \%v\{(rg * sg)\}$

### Hints:

- There are no hints for this problem. The next hint will reveal the answer.
- The value of x is  $\%v\{(sg * rh)\} / \%v\{(rg * sg)\}$

Please type  $\%v\{(sg * rh)\} / \%v\{(rg * sg)\}$

### 6) Assistment #69076 "69076 - 60008 - Systems of Equations - Linear Combination (Hints)"

Solve the following system of equations using linear combination.

$$-7y + 6x = 4$$

$$-6y + 6x = -2$$

What is the value of x?

(Enter as a fraction)

**Algebra:**

✓ -6.33333333333333

✗ -6

### Hints:

- The problem asks you to find the value of x using linear combination.

We need to subtract one equation from the other in a way that makes any terms containing the variable y cancel out.

One way to do this is to multiply both sides of each equation by the y coefficient of the other equation.

$$-7y + 6x = 4$$

$$-6y + 6x = -2$$

The **first equation** is multiplied by **-6**, which is the y coefficient of the **second equation**.

The **second equation** is multiplied by **-7**, which is the y coefficient of the **first equation**.

$$-6 * (-7y + 6x) = -6 * 4$$

$$-7 * (-6y + 6x) = -7 * -2$$

$$42y - 36x = -24$$

$$42y - 42x = 14$$

- Now subtract one equation from the other.

$$42y - 36x = -24$$

$$42y - 42x = 14$$

$$\begin{array}{rcl} 42y - 36x & = & -24 \\ - (42y - 42x) & & - (14) \end{array}$$

$$6x = -38$$

*Notice how the terms containing the variable  $y$  cancel out.*

- Now we have an equation with only one unknown variable,  $x$ . The last step is to solve this new equation for  $x$ .

$$6x = -38$$

$$6x / 6 = -38 / 6$$

$$x = -38 / 6$$

The value of  $x$  is  $-38 / 6$

Please type  $-38 / 6$

**Hints:**

- There are no hints for this problem. The next hint will reveal the answer.
- The value of  $x$  is  $-38 / 6$

Please type  $-38 / 6$

---

# Algebra

Skill <b>Solving Systems of Equations Story Problems</b>	Class <b>Algebra I</b>
---	---------------------------

## THE MASTERY SET

Mastery Problem Set <input type="text" value="#8924"/>	Number of Templates <input type="text" value="6"/>
Number to Master <input type="text" value="3 in-a-row"/>	Number of Attempts <input type="text" value="10 First Day, 10 Subsequent Days"/>

## Templates

63550

Victoria's father is 8 times as old as Victoria. 15 years from now, Victoria will be  $\frac{1}{3}$  as old as her father. How old is Victoria's father?

[Comment on this question](#)

Show me hint 1 of 3

Type your answer below (mathematical expression):

Submit Answer

- Child's name is selected from ten available names
- Child's age is between 2 and 6
- Parent's age is between 22 and 48
- Number of years is between 1 and 20
- Fractions have numerator of 1 and single-digit, integer denominators

56572

Ursula bought 5 Figs and 5 Papayas at the local supermarket for a total of \$27  
Keely bought 8 Figs and 6 Papayas at the same store for a total of \$36.80  
How much does one Fig cost?

[Comment on this question](#)

Show me hint 1 of 4

Type your answer below (mathematical expression):

Submit Answer

How much does one Papaya cost?

[Comment on this question](#)

Show me hint 1 of 3

Type your answer below (mathematical expression):

Submit Answer

- Names and produce selected randomly
- All quantities between 2 and 11
- Cost of first item between \$0.50 and \$2.40
- Cost of second item between \$2.50 and \$4.40
- No fractions of cents in prices
- Cannot generate unsolvable or parallel equations

62915

Jose has \$3.60 in nickels and dimes. If he has a total of 48 coins, how many of the coins are nickels?

[Comment on this question](#)

Show me hint 1 of 3

Type your answer below (mathematical expression):

Submit Answer



How many dimes does Jose have?

[Comment on this question](#)

Show me hint 1 of 3

Type your answer below (mathematical expression):

Submit Answer

- Names selected randomly
- Coins can be nickels, dimes, or quarters
- Quantity of each type of coin is between 10 and 49
- Cannot generate unsolvable or parallel equations

62904

Four times the sum of the digits of a positive, two-digit integer is 53 greater than the ones digit. Reversing the digits decreases the number by 9. What is the number?

[Comment on this question](#)

Show me hint 1 of 3

Type your answer below (mathematical expression):

Submit Answer

- First statement compares sum of digits, difference of digits, tens digit, or ones digit to another.
- Multiple in first statement is between 2 and 5
- Second statement always reverses digits

68665

A boat travelling upstream goes 72 miles in 8 hours. If the return trip takes only 3 hours, what is the speed (in miles per hour) of the boat in still water?

[Comment on this question](#)

Show me hint 1 of 3

Type your answer below (mathematical expression):

Submit Answer

- Distance in miles or kilometers
- Upstream travel time from 6 to 9 hours
- Downstream travel time from 2 to 5 hours
- Distance is a multiple of both travel times

63598

A hardware store clerk mixed nuts worth \$0.48 per pound with bolts worth \$1.44 per pound. If she made 108 pounds of a mixture worth \$1.20 per pound, how many pounds of bolts are in the mixture?

[Comment on this question](#)

Show me hint 1 of 3

Type your answer below (mathematical expression):

Submit Answer

- Items can be nuts, candy, or hardware
- Problem can ask for price of either item
- Amounts in pounds or kilograms
- Amount of first item is between 10 and 29
- Amount of second item is a multiple from 2 to 5 of the first item
- Cannot generate fractions of cents or units

## Problem Set "Systems of Equations Story Problems - Printout" id:[10916]

### 1) Assistent #63598 "63598 - Systems of Equations - The Mixture Problem (Hints)"

A person mixed  $x$  items worth  $\$p_1$  per unit with  $y$  items worth  $\$p_2$  per unit. If the mixture made  $z$  items of a mixture worth  $\$p_3$  per unit, how many items of  $x$  and  $y$  are in the mixture?

#### Algebra:

✓  $x$

✗  $y$

#### Hints:

- First, use the information in the problem to write a system of equations. Let  $x$  represent the number of  $x$ 's and  $y$  represent the number of  $y$ 's.

We know there is a total of  $z$  items in the mixture, so

$$x + y = z$$

The total price can be calculated by multiplying the price per unit by the number of units.

Therefore, the total price of the  $x$ 's in the mixture is

$$p_1 x$$

the total price of the  $y$ 's in the mixture is

$$p_2 y$$

and the total price of the mixture is

$$p_3 z$$

The total price of the mixture is just the sum of the total prices of the  $x$ 's and the  $y$ 's, so

$$p_1 x + p_2 y = p_3 z$$

$$p_1 x + p_2 y = p_3 z$$

Now we have two equations and two unknowns, so we can solve the system of equations.

$$x + y = z$$

$$p_1 x + p_2 y = p_3 z$$

- We need to solve the system of equations

$$x + y = z$$

$$p_1 x + p_2 y = p_3 z$$

We will use linear combination.

To find the value of  $x$  we need to cancel out the terms containing

$y$ . Multiply both sides of the first equation by the coefficient of  $y$  in the second equation.

$$(x + y = z) * p_2 = p_2 x + p_2 y = p_2 z$$

$$p_1 x + p_2 y = p_3 z$$

$$= p_2 z - p_2 y + p_1 x = p_3 z$$

Now, subtract the first equation from the second.

$$p_1 x + p_2 y = p_3 z$$

$$p_1 x + p_2 y = p_2 z$$

$$p_1 x + p_2 y = p_3 z$$

$$\begin{aligned} & \%v\{\text{price1}\}\%v\{\text{var1}\} + \%v\{\text{price2}\}\%v\{\text{var2}\} - \%v\{((\text{find} == 0) ? \text{price2} : \text{price1})\}\%v\{\text{var1}\} - \\ & \%v\{((\text{find} == 0) ? \text{price2} : \text{price1})\}\%v\{\text{var2}\} = \%v\{\text{price3} * \text{amount3}\} - \%v\{(\text{amount3} * ((\text{find} == 0) ? \\ & \text{price2} : \text{price1}))\} \end{aligned}$$

Now we have one equation with one variable, and we can solve for  $\%v\{((\text{find} == 0) ? \text{var1} : \text{var2})\}$ .

- We need to find the value of  $\%v\{((\text{find} == 0) ? \text{var1} : \text{var2})\}$ . Solve the equation we found earlier for  $\%v\{((\text{find} == 0) ? \text{var1} : \text{var2})\}$ .  

$$\begin{aligned} & \%v\{\text{price1}\}\%v\{\text{var1}\} + \%v\{\text{price2}\}\%v\{\text{var2}\} - \%v\{((\text{find} == 0) ? \text{price2} : \text{price1})\}\%v\{\text{var1}\} - \\ & \%v\{((\text{find} == 0) ? \text{price2} : \text{price1})\}\%v\{\text{var2}\} = \%v\{\text{price3} * \text{amount3}\} - \%v\{(\text{amount3} * ((\text{find} == 0) ? \\ & \text{price2} : \text{price1}))\} \\ & \%v\{\text{float2}\}\%v\{((\text{find} == 0) ? \text{var1} : \text{var2})\} = \%v\{\text{float1}\} \\ & \%v\{\text{float2}\}\%v\{((\text{find} == 0) ? \text{var1} : \text{var2})\} / \%v\{\text{float2}\} = \%v\{\text{float1}\} / \%v\{\text{float2}\} \\ & \%v\{((\text{find} == 0) ? \text{var1} : \text{var2})\} = \%v\{((\text{find} == 0) ? \text{amount1} : \text{amount2})\} \end{aligned}$$

The value of  $\%v\{((\text{find} == 0) ? \text{var1} : \text{var2})\}$  is  $\%v\{((\text{find} == 0) ? \text{amount1} : \text{amount2})\}$ . Because  $\%v\{((\text{find} == 0) ? \text{var1} : \text{var2})\}$  represents the number of  $\%v\{\text{unit}\}$ s of  $\%v\{((\text{find} == 0) ? \text{item1} : \text{item2})\}$ s, there are  $\%v\{((\text{find} == 0) ? \text{amount1} : \text{amount2})\} \%v\{\text{unit}\}$ s of  $\%v\{((\text{find} == 0) ? \text{item1} : \text{item2})\}$ s in the mixture.

Please type  $\%v\{((\text{find} == 0) ? \text{amount1} : \text{amount2})\}$

### Hints:

- There are no hints for this problem. The next hint will reveal the answer.
- There are  $\%v\{\text{answer}\} \%v\{\text{unit}\}$ s of  $\%v\{((\text{find} == 0) ? \text{item1} : \text{item2})\}$ s in the mixture. Please type  $\%v\{\text{answer}\}$

## 2) Assistment #68931 "68931 - 63598 - Systems of Equations - The Mixture Problem (Hints)"

A grocer mixed pecans worth \$0.84 per pound with cashews worth \$1.40 per pound. If he made 88 pounds of a mixture worth \$1.26 per pound, how many pounds of pecans are in the mixture?

### Algebra:

✓ 22

✗ 66

### Hints:

- First, use the information in the problem to write a system of equations. Let  $p$  represent the number of pounds of **pecans** and  $c$  represent the number of pounds of **cashews**.

We know there is a total of **88** pounds in the mixture, so

$$p + c = 88$$

The total price can be calculated by multiplying the **price per pound** by the number of pounds.

Therefore, the total price of the **pecans** in the mixture is

$$0.84 * p$$

the total price of the **cashews** in the mixture is

$$1.4 * c$$

and the total price of the mixture is

$$1.26 * 88$$

The total price of the mixture is just the sum of the total prices of the **pecans** and the **cashews**, so

$$0.84 * p + 1.4 * c = 1.26 * 88$$

$$0.84p + 1.4c = 110.88$$

Now we have two equations and two unknowns, so we can solve the system of equations.

$$p + c = 88$$

$$0.84p + 1.4c = 110.88$$

- We need to solve the system of equations

$$p + c = 88$$

$$0.84p + 1.4c = 110.88$$

We will use linear combination.

To find the value of  $p$  we need to cancel out the terms containing  $c$ . Multiply both sides of the first equation by the coefficient of  $c$ .

$$(p + c) * 1.4 = 88 * 1.4$$

$$1.4p + 1.4c = 123.2$$

Now, subtract the first equation from the second.

$$1.4p + 1.4c = 123.2$$

$$0.84p + 1.4c = 110.88$$

$$0.84p + 1.4c - 1.4p - 1.4c = 110.88 - 123.2$$

Now we have one equation with one variable, and we can solve for  $p$ .

- We need to find the value of  $p$ . Solve the equation we found earlier for  $p$ .

$$0.84p + 1.4c - 1.4p - 1.4c = 110.88 - 123.2$$

$$-0.56p = -12.32$$

$$-0.56p / -0.56 = -12.32 / -0.56$$

$$p = 22$$

The value of  $p$  is 22. Because  $p$  represents the number of pounds of pecans, there are 22 pounds of pecans in the mixture.

Please type 22

#### Hints:

- There are no hints for this problem. The next hint will reveal the answer.
- There are 22 pounds of pecans in the mixture.  
Please type 22

### 3) Assistment #68665 "68665 - Systems of Equations - The Current Problem (Hints)"

A boat travelling upstream goes  $\%v\{\text{distance}\} \%v\{\text{unit}\}$ s in  $\%v\{\text{upstream}\}$  hours. If the return trip takes only  $\%v\{\text{downstream}\}$  hours, what is the speed (in  $\%v\{\text{unit}\}$ s per hour) of the boat in still water?

#### Algebra:

✓  $\%v\{\text{speed}\}$

✗  $\%v\{\text{current}\}$

#### Hints:

- There are no hints for this problem. The next hint will reveal the answer.
- The speed of the boat in still water is  $\%v\{\text{speed}\} \%v\{\text{unit}\}$ s per hour.

Please type  $\%v\{\text{speed}\}$

#### Hints:

- First, use the information in the problem to write a system of equations. Let  $b$  represent the speed of the boat and  $c$  represent the speed of the current.

The speed of the boat going **upstream** is

$$b - c$$

because the current flows against the direction the boat is trying to go.

The speed of the boat going **downstream** is

$$b + c$$

because the current flows in the same direction the boat is trying to go.

We know that

$$\text{rate} * \text{time} = \text{distance}$$

Substitute the expressions from the problem into this equation.

$$\text{rate} * \text{time} = \text{distance}$$

$$(b - c) * \%v\{\text{upstream}\} = \%v\{\text{distance}\}$$

$$(b + c) * \%v\{\text{downstream}\} = \%v\{\text{distance}\}$$

Now we have two equations and two variables, so we can solve the system of equations.

- We need to solve the system of equations

$$(b - c) * \%v\{\text{upstream}\} = \%v\{\text{distance}\}$$

$$(b + c) * \%v\{\text{downstream}\} = \%v\{\text{distance}\}$$

We will use linear combination.

First, simplify the equations.

$$(b - c) * \%v\{\text{upstream}\} = \%v\{\text{distance}\}$$

$$(b - c) * \%v\{\text{upstream}\} / \%v\{\text{upstream}\} = \%v\{\text{distance}\} / \%v\{\text{upstream}\}$$

$$b - c = \%v\{\text{distance} / \text{upstream}\}$$

$$(b + c) * \%v\{\text{downstream}\} = \%v\{\text{distance}\}$$

$$(b + c) * \%v\{\text{downstream}\} / \%v\{\text{downstream}\} = \%v\{\text{distance}\} / \%v\{\text{downstream}\}$$

$$b + c = \%v\{\text{distance} / \text{downstream}\}$$

Next, add the two equations together.

$$b - c = \%v\{\text{distance} / \text{upstream}\}$$

$$b + c = \%v\{\text{distance} / \text{downstream}\}$$

$$b - c + b + c = \%v\{\text{distance} / \text{upstream}\} + \%v\{\text{distance} / \text{downstream}\}$$

$$2b = \%v\{\text{distance} / \text{upstream} + \text{distance} / \text{downstream}\}$$

Now we have an equation with only one variable, so we can solve for **b**.

$$2b = \%v\{\text{distance} / \text{upstream} + \text{distance} / \text{downstream}\}$$

$$2b / 2 = \%v\{\text{distance} / \text{upstream} + \text{distance} / \text{downstream}\} / 2$$

$$b = \%v\{\text{speed}\}$$

- The value of **b** is  $\%v\{\text{speed}\}$ . Because **b** represents the speed of the boat in **still water**, the speed of the boat in still water is  $\%v\{\text{speed}\} \%v\{\text{unit}\}$ s per hour.

Please type  $\%v\{\text{speed}\}$

#### 4) Assistment #68941 "68941 - 68665 - Systems of Equations - The Current Problem (Hints)"

A boat travelling upstream goes 225 kilometers in 9 hours. If the return trip takes only 5 hours, what is the speed (in kilometers per hour) of the boat in still water?

**Algebra:**

✓ 35

✗ 10

### Hints:

- First, use the information in the problem to write a system of equations. Let **b** represent the speed of the boat and **c** represent the speed of the current.

The speed of the boat going upstream is

$$b - c$$

because the current flows against the direction the boat is trying to go.

The speed of the boat going downstream is

$$b + c$$

because the current flows in the same direction the boat is trying to go.

We know that

$$\text{rate} * \text{time} = \text{distance}$$

Substitute the expressions from the problem into this equation.

$$\text{rate} * \text{time} = \text{distance}$$

$$(b - c) * 9 = 225$$

$$(b + c) * 5 = 225$$

Now we have two equations and two variables, so we can solve the system of equations.

- We need to solve the system of equations

$$(b - c) * 9 = 225$$

$$(b + c) * 5 = 225$$

We will use linear combination.

First, simplify the equations.

$$(b - c) * 9 = 225$$

$$(b - c) * 9 / 9 = 225 / 9$$

$$b - c = 25$$

$$(b + c) * 5 = 225$$

$$(b + c) * 5 / 5 = 225 / 5$$

$$b + c = 45$$

Next, add the two equations together.

$$b - c = 25$$

$$b + c = 45$$

$$b - c + b + c = 25 + 45$$

$$2b = 70$$

Now we have an equation with only one variable, so we can solve for **b**.

$$2b = 70$$

$$2b / 2 = 70 / 2$$

$$b = 35$$

- The value of **b** is 35. Because **b** represents the speed of the boat in still water, the speed of the boat in still water is 35 kilometers per hour.

Please type 35

**Hints:**

- There are no hints for this problem. The next hint will reveal the answer.
- The speed of the boat in still water is 35 kilometers per hour.

Please type 35

**5) Assistent #62915 "62915 - Systems of Equations - The Coin Problem (Hints)"**

A)  $\%v\{\text{name}\}$  has  $\%v\{\text{total} / 100\} \%v\{((\text{zero} == 0) ? "0" : "")\}$  in  $\%v\{((\text{coin1} == 0) ? "nickel" : ((\text{coin1} == 1) ? "dime" : "quarter"))\}$ s and  $\%v\{((\text{coin2} == 0) ? "nickel" : ((\text{coin2} == 1) ? "dime" : "quarter"))\}$ s. If  $\%v\{\text{gender}\}$  has a total of  $\%v\{\text{quantity}\}$  coins, how many of the coins are  $\%v\{((\text{coin1} == 0) ? "nickel" : ((\text{coin1} == 1) ? "dime" : "quarter"))\}$ s?

**Algebra:**

✓  $\%v\{\text{quantity1}\}$

✗  $\%v\{\text{quantity2}\}$

**Hints:**

- There are no hints for this problem. The next hint will reveal the answer.
- $\%v\{\text{name}\}$  has  $\%v\{\text{quantity1}\} \%v\{((\text{coin1} == 0) ? "nickel" : ((\text{coin1} == 1) ? "dime" : "quarter"))\}$ s. Please type  $\%v\{\text{quantity1}\}$

**Hints:**

- First, use the problem to write a system of equations. Let  $\%v\{((\text{coin1} == 0) ? "n" : ((\text{coin1} == 1) ? "d" : "q"))\}$  represent the number of  $\%v\{((\text{coin1} == 0) ? "nickel" : ((\text{coin1} == 1) ? "dime" : "quarter"))\}$ s and  $\%v\{((\text{coin2} == 0) ? "n" : ((\text{coin2} == 1) ? "d" : "q"))\}$  represent the number of  $\%v\{((\text{coin2} == 0) ? "nickel" : ((\text{coin2} == 1) ? "dime" : "quarter"))\}$ s.

We know that the total value of the coins is  $\%v\{\text{total} / 100\} \%v\{((\text{zero} == 0) ? "0" : "")\}$ . Each  $\%v\{((\text{coin1} == 0) ? "nickel" : ((\text{coin1} == 1) ? "dime" : "quarter"))\}$  is worth  $\%v\{\text{value1} / 100\}$  and each  $\%v\{((\text{coin2} == 0) ? "nickel" : ((\text{coin2} == 1) ? "dime" : "quarter"))\}$  is worth  $\%v\{\text{value2} / 100\}$ , so we can write the equation

$$\%v\{\text{value1} / 100\} \%v\{((\text{coin1} == 0) ? "n" : ((\text{coin1} == 1) ? "d" : "q"))\} + \%v\{\text{value2} / 100\} \%v\{((\text{coin2} == 0) ? "n" : ((\text{coin2} == 1) ? "d" : "q"))\} = \%v\{\text{total} / 100\}$$

We also know that the total number of coins is  $\%v\{\text{quantity}\}$ , so we can write the equation

$$\%v\{((\text{coin1} == 0) ? "n" : ((\text{coin1} == 1) ? "d" : "q"))\} + \%v\{((\text{coin2} == 0) ? "n" : ((\text{coin2} == 1) ? "d" : "q"))\} = \%v\{\text{quantity}\}$$

We now have a system of equations with two variables and two equations, and we can solve for the number of  $\%v\{((\text{coin1} == 0) ? "nickel" : ((\text{coin1} == 1) ? "dime" : "quarter"))\}$ s.

- We need to solve the system of equations
 
$$\%v\{\text{value1} / 100\} \%v\{((\text{coin1} == 0) ? "n" : ((\text{coin1} == 1) ? "d" : "q"))\} + \%v\{\text{value2} / 100\} \%v\{((\text{coin2} == 0) ? "n" : ((\text{coin2} == 1) ? "d" : "q"))\} = \%v\{\text{total} / 100\}$$

$$\%v\{((\text{coin1} == 0) ? "n" : ((\text{coin1} == 1) ? "d" : "q"))\} + \%v\{((\text{coin2} == 0) ? "n" : ((\text{coin2} == 1) ? "d" : "q"))\} = \%v\{\text{quantity}\}$$

We will use linear combination in this example.

First, remove the decimals from the first equation by multiplying each side by 100.

$$\%v\{\text{value1} / 100\} \%v\{((\text{coin1} == 0) ? "n" : ((\text{coin1} == 1) ? "d" : "q"))\} + \%v\{\text{value2} / 100\} \%v\{((\text{coin2} == 0) ? "n" : ((\text{coin2} == 1) ? "d" : "q"))\} = \%v\{\text{total} / 100\}$$

$$(\%v\{\text{value1} / 100\} \%v\{((\text{coin1} == 0) ? "n" : ((\text{coin1} == 1) ? "d" : "q"))\} + \%v\{\text{value2} / 100\} \%v\{((\text{coin2} == 0) ? "n" : ((\text{coin2} == 1) ? "d" : "q"))\}) \cdot 100 = \%v\{\text{total}\}$$



$$= 0) ? "n" : ((coin2 == 1) ? "d" : "q")) * 100 = \%v\{total / 100\} * 100$$

$$\%v\{value1\}\%v\{((coin1 == 0) ? "n" : ((coin1 == 1) ? "d" : "q"))\} + \%v\{value2\}\%v\{((coin2 == 0) ? "n" : ((coin2 == 1) ? "d" : "q"))\} = \%v\{total\}$$

Next, we multiply both sides of the second equation by the coefficient of  $\%v\{((coin2 == 0) ? "n" : ((coin2 == 1) ? "d" : "q"))\}$  in the first equation. This way, the terms containing  $\%v\{((coin2 == 0) ? "n" : ((coin2 == 1) ? "d" : "q"))\}$  will cancel out when we subtract one equation from the other.

$$\%v\{((coin1 == 0) ? "n" : ((coin1 == 1) ? "d" : "q"))\} + \%v\{((coin2 == 0) ? "n" : ((coin2 == 1) ? "d" : "q"))\} = \%v\{quantity\}$$

$$(\%v\{((coin1 == 0) ? "n" : ((coin1 == 1) ? "d" : "q"))\} + \%v\{((coin2 == 0) ? "n" : ((coin2 == 1) ? "d" : "q"))\}) * \%v\{value2\} = \%v\{quantity\} * \%v\{value2\}$$

$$\%v\{value2\}\%v\{((coin1 == 0) ? "n" : ((coin1 == 1) ? "d" : "q"))\} + \%v\{value2\}\%v\{((coin2 == 0) ? "n" : ((coin2 == 1) ? "d" : "q"))\} = \%v\{quantity * value2\}$$

We now have the equations

$$\%v\{value1\}\%v\{((coin1 == 0) ? "n" : ((coin1 == 1) ? "d" : "q"))\} + \%v\{value2\}\%v\{((coin2 == 0) ? "n" : ((coin2 == 1) ? "d" : "q"))\} = \%v\{total\}$$

$$\%v\{value2\}\%v\{((coin1 == 0) ? "n" : ((coin1 == 1) ? "d" : "q"))\} + \%v\{value2\}\%v\{((coin2 == 0) ? "n" : ((coin2 == 1) ? "d" : "q"))\} = \%v\{quantity * value2\}$$

Next, subtract the second equation from the first.

$$\%v\{value1\}\%v\{((coin1 == 0) ? "n" : ((coin1 == 1) ? "d" : "q"))\} + \%v\{value2\}\%v\{((coin2 == 0) ? "n" : ((coin2 == 1) ? "d" : "q"))\} - \%v\{value2\}\%v\{((coin1 == 0) ? "n" : ((coin1 == 1) ? "d" : "q"))\} - \%v\{value2\}\%v\{((coin2 == 0) ? "n" : ((coin2 == 1) ? "d" : "q"))\} = \%v\{total\} - \%v\{quantity * value2\}$$

$$\%v\{value1 - value2\}\%v\{((coin1 == 0) ? "n" : ((coin1 == 1) ? "d" : "q"))\} = \%v\{total - quantity * value2\}$$

Now we have one equation with one variable, and we can solve for  $\%v\{((coin1 == 0) ? "n" : ((coin1 == 1) ? "d" : "q"))\}$ .

$$\%v\{value1 - value2\}\%v\{((coin1 == 0) ? "n" : ((coin1 == 1) ? "d" : "q"))\} / \%v\{value1 - value2\} = \%v\{total - quantity * value2\} / \%v\{value1 - value2\}$$

$$\%v\{((coin1 == 0) ? "n" : ((coin1 == 1) ? "d" : "q"))\} = \%v\{quantity1\}$$

- The variable  $\%v\{((coin1 == 0) ? "n" : ((coin1 == 1) ? "d" : "q"))\}$  represents the number of  $\%v\{((coin1 == 0) ? "nickel" : ((coin1 == 1) ? "dime" : "quarter"))\}$ s, so  $\%v\{name\}$  has  $\%v\{quantity1\} \%v\{((coin1 == 0) ? "nickel" : ((coin1 == 1) ? "dime" : "quarter"))\}$ s.

Please type  $\%v\{quantity1\}$

**B)** How many  $\%v\{((coin2 == 0) ? "nickel" : ((coin2 == 1) ? "dime" : "quarter"))\}$ s does  $\%v\{name\}$  have?

**Algebra:**

✓  $\%v\{quantity2\}$

✗  $\%v\{quantity1\}$

**Hints:**

- The problem states that  $\%v\{name\}$  has a total of  $\%v\{quantity\}$  coins, and we found earlier that  $\%v\{quantity1\}$  of them are  $\%v\{((coin1 == 0) ? "nickel" : ((coin1 == 1) ? "dime" : "quarter"))\}$ s. Because the rest of the coins are  $\%v\{((coin2 == 0) ? "nickel" : ((coin2 == 1) ? "dime" : "quarter"))\}$ s, we can write the equation

$$\%v\{quantity\} = \%v\{quantity1\} + \%v\{((coin2 == 0) ? "n" : ((coin2 == 1) ? "d" : "q"))\}$$

where  $\%v\{((coin2 == 0) ? "n" : ((coin2 == 1) ? "d" : "q"))\}$  represents the number of  $\%v\{((coin2 == 0) ? "nickel" : ((coin2 == 1) ? "dime" : "quarter"))\}$ s.

- Now solve the equation for  $\%v\{((coin2 == 0) ? "n" : ((coin2 == 1) ? "d" : "q"))\}$
- $$\%v\{quantity\} = \%v\{quantity1\} + \%v\{((coin2 == 0) ? "n" : ((coin2 == 1) ? "d" : "q"))\}$$

$$\%v\{\text{quantity}\} - \%v\{\text{quantity1}\} = \%v\{\text{quantity1}\} + \%v\{((\text{coin2} == 0) ? "n" : ((\text{coin2} == 1) ? "d" : "q"))\}$$

$$- \%v\{\text{quantity1}\}$$

$$\%v\{((\text{coin2} == 0) ? "n" : ((\text{coin2} == 1) ? "d" : "q"))\} = \%v\{\text{quantity} - \text{quantity1}\}$$

- The variable  $\%v\{((\text{coin2} == 0) ? "n" : ((\text{coin2} == 1) ? "d" : "q"))\}$  represents the number of  $\%v\{((\text{coin2} == 0) ? "nickel" : ((\text{coin2} == 1) ? "dime" : "quarter"))\}$ s, so  $\%v\{\text{name}\}$  has  $\%v\{\text{quantity2}\} \%v\{((\text{coin2} == 0) ? "nickel" : ((\text{coin2} == 1) ? "dime" : "quarter"))\}$ s.

Please type  $\%v\{\text{quantity2}\}$

### Hints:

- There are no hints for this problem. The next hint will reveal the answer.
- $\%v\{\text{name}\}$  has  $\%v\{\text{quantity2}\} \%v\{((\text{coin2} == 0) ? "nickel" : ((\text{coin2} == 1) ? "dime" : "quarter"))\}$ s.  
Please type  $\%v\{\text{quantity2}\}$

## 6) Assistment #68910 "68910 - 62915 - Systems of Equations - The Coin Problem (Hints)"

A) Walter has \$7.55 in quarters and dimes. If he has a total of 47 coins, how many of the coins are quarters?

### Algebra:

✓ 19

✗ 28

### Hints:

- First, use the problem to write a system of equations. Let  $q$  represent the number of quarters and  $d$  represent the number of dimes.

We know that the total value of the coins is \$7.55. Each quarter is worth \$0.25 and each dime is worth \$0.1, so we can write the equation

$$0.25q + 0.1d = 7.55$$

We also know that the total number of coins is 47, so we can write the equation

$$q + d = 47$$

We now have a system of equations with two variables and two equations, and we can solve for the number of quarters.

- We need to solve the system of equations

$$0.25q + 0.1d = 7.55$$

$$q + d = 47$$

We will use linear combination in this example.

First, remove the decimals from the first equation by multiplying each side by 100.

$$0.25q + 0.1d = 7.55$$

$$(0.25q + 0.1d) * 100 = 7.55 * 100$$

$$25q + 10d = 755$$

Next, we multiply both sides of the second equation by the coefficient of  $d$  in the first equation. This way, the terms containing  $d$  will cancel out when we subtract one equation from the other.

$$q + d = 47$$

$$(q + d) * 10 = 47 * 10$$

$$10q + 10d = 470$$

We now have the equations

$$25q + 10d = 755$$

$$10q + 10d = 470$$

Next, subtract the second equation from the first.

$$25q + 10d - 10q - 10d = 755 - 470$$

$$15q = 285$$

Now we have one equation with one variable, and we can solve for  $q$ .

$$15q / 15 = 285 / 15$$

$$q = 19$$

- The variable  $q$  represents the number of **quarters**, so Walter has 19 **quarters**.  
Please type 19

**Hints:**

- There are no hints for this problem. The next hint will reveal the answer.
- Walter has 19 quarters.  
Please type 19

**B) How many dimes does Walter have?**

**Algebra:**

✓ 28

✗ 19

**Hints:**

- The problem states that Walter has a total of 47 coins, and we found earlier that 19 of them are **quarters**. Because the rest of the coins are **dimes**, we can write the equation  
 $47 = 19 + d$   
where  $d$  represents the number of **dimes**.
- Now solve the equation for  $d$   
 $47 = 19 + d$   
 $47 - 19 = 19 + d - 19$   
 $d = 28$
- The variable  $d$  represents the number of **dimes**, so Walter has 28 **dimes**.  
Please type 28

**Hints:**

- There are no hints for this problem. The next hint will reveal the answer.
- Walter has 28 dimes.  
Please type 28

**7) Assistment #62904 "62904 - Systems of Equations - The Digits Problem (Hints)"**

$\%v\{((multiple == 2) ? "Twice" : ((multiple == 3) ? "Three times" : ((multiple == 4) ? "Four times" : "Five times")))\}$  the  $\%v\{((type1 == 0) ? "ones digit" : ((type1 == 1) ? "tens digit" : ((type1 == 2) ? "difference of the digits" : "sum of the digits"))\}$  of a positive, two-digit integer is  $\%v\{((sign1 == 0) ? "" : magnitude1)\}\%v\{((sign1 == 1) ? " greater than" : ((sign1 == 0) ? "equal to" : " less than"))\}$  the  $\%v\{((type2 == 0) ? "ones digit" : ((type2 == 1) ? "tens digit" : ((type2 == 2) ? "difference of the digits" : "sum of the digits"))\}$ . Reversing the digits  $\%v\{((sign2 == 0) ? "does not change" : ((sign2 == 1) ? "increases" : "decreases"))\}$  the number $\%v\{((sign2 == 0) ? "" : " by ") \}\%v\{((sign2 == 0) ? "" : magnitude2)\}$ . What is the number?

**Algebra:**

✓  $\%v\{\text{answer}\}$

**Hints:**

- The first step is to use the problem to write a system of equations. Let the variable  $x$  represent the tens digit and the variable  $y$  represent the ones digit.

$\%v\{((\text{strategy} == 0) ? "" : "Because reversing the digits ") \%v\{((\text{strategy} == 1) ? "increases" : ((\text{strategy} == -1) ? "decreases" : "")) \%v\{((\text{strategy} == 0) ? "" : " the number, we know that x is ") \%v\{((\text{strategy} == 1) ? "less" : ((\text{strategy} == -1) ? "greater" : "")) \%v\{((\text{strategy} == 0) ? "" : " than y. Therefore, the difference of the digits is ") \%v\{((\text{strategy} == 1) ? "y - x" : ((\text{strategy} == -1) ? "x - y" : ""))\}$

$\%v\{((\text{multiple} == 2) ? "Twice" : ((\text{multiple} == 3) ? "Three times" : ((\text{multiple} == 4) ? "Four times" : "Five times"))\}$  the  $\%v\{((\text{type1} == 0) ? "ones digit" : ((\text{type1} == 1) ? "tens digit" : ((\text{type1} == 2) ? "difference of the digits" : "sum of the digits"))\}$  of a positive, two-digit integer is  $\%v\{((\text{sign1} == 0) ? "" : \text{magnitude1})\} \%v\{((\text{sign1} == 1) ? " greater than" : ((\text{sign1} == 0) ? "equal to" : " less than"))\}$  the  $\%v\{((\text{type2} == 0) ? "ones digit" : ((\text{type2} == 1) ? "tens digit" : ((\text{type2} == 2) ? "difference of the digits" : "sum of the digits"))\}$ .

$\%v\{\text{multiple}\} \%v\{((\text{type1} == 0) ? "y" : ((\text{type1} == 1) ? "x" : ((\text{type1} == 3) ? "(x + y)" : ((\text{strategy} == -1) ? "(x - y)" : "(y - x)"))))\} = \%v\{((\text{type2} == 0) ? "y" : ((\text{type2} == 1) ? "x" : ((\text{type2} == 3) ? "(x + y)" : ((\text{strategy} == -1) ? "(x - y)" : "(y - x)"))))\} \%v\{((\text{sign1} == 1) ? "+" : ((\text{sign1} == -1) ? "-" : ""))\} \%v\{((\text{sign1} == 0) ? "" : \text{magnitude1})\}$

**Reversing the digits**  $\%v\{((\text{sign2} == 0) ? "does not change" : ((\text{sign2} == 1) ? "increases" : "decreases"))\}$  the number  $\%v\{((\text{sign2} == 0) ? "" : " by ") \%v\{((\text{sign2} == 0) ? "" : \text{magnitude2})\}$ .  
 $10y + x = 10x + y \%v\{((\text{sign2} == 0) ? "" : ((\text{sign2} == 1) ? "+" : "-"))\} \%v\{((\text{sign2} == 0) ? "" : \text{magnitude2})\}$

We now have a system of equations with two variables and two equations.

- The next step is to solve the system of equations. First, simplify the equations and combine terms.  
 $\%v\{\text{multiple}\} \%v\{((\text{type1} == 0) ? "y" : ((\text{type1} == 1) ? "x" : ((\text{type1} == 3) ? "(x + y)" : ((\text{strategy} == -1) ? "(x - y)" : "(y - x)"))))\} = \%v\{((\text{type2} == 0) ? "y" : ((\text{type2} == 1) ? "x" : ((\text{type2} == 3) ? "(x + y)" : ((\text{strategy} == -1) ? "(x - y)" : "(y - x)"))))\} \%v\{((\text{sign1} == 1) ? "+" : ((\text{sign1} == -1) ? "-" : ""))\} \%v\{((\text{sign1} == 0) ? "" : \text{magnitude1})\}$

$\%v\{\text{multiple}\} \%v\{((\text{type1} == 0) ? "y" : ((\text{type1} == 1) ? "x" : ((\text{type1} == 3) ? "x + " : ((\text{strategy} == -1) ? "x - " : "y - ")))\} \%v\{((\text{type1} == 0) ? "" : ((\text{type1} == 1) ? "" : \text{multiple}))\} \%v\{((\text{type1} == 3) ? "y" : ((\text{type1} == 2) ? ((\text{strategy} == -1) ? "y" : "x") : ""))\} \%v\{((\text{coefficient3} == 0) ? "" : ((\text{coefficient3} == 1) ? "- x" : "+ x"))\} \%v\{((\text{coefficient4} == 0) ? "" : ((\text{coefficient4} == 1) ? "- y" : "+ y"))\} = \%v\{((\text{type2} == 0) ? "y" : ((\text{type2} == 1) ? "x" : ((\text{type2} == 3) ? "x + y" : ((\text{strategy} == -1) ? "x - y" : "y - x"))))\} \%v\{((\text{sign1} == 1) ? "+" : ((\text{sign1} == -1) ? "-" : ""))\} \%v\{((\text{sign1} == 0) ? "" : \text{magnitude1})\} \%v\{((\text{coefficient3} == 0) ? "" : ((\text{coefficient3} == 1) ? "- x" : "+ x"))\} \%v\{((\text{coefficient4} == 0) ? "" : ((\text{coefficient4} == 1) ? "- y" : "+ y"))\}$

$\%v\{((\text{co2s} == 0) ? "" : ((\text{co2s} == 1) ? "" : "-"))\} \%v\{((\text{co2s} == 0) ? "" : ((\text{co2a} == 1) ? "" : \text{co2a}))\} \%v\{((\text{co2s} == 0) ? "" : "y")\} \%v\{((\text{co1s} == 0) ? "" : ((\text{co1s} == 1) ? "+" : "-"))\} \%v\{((\text{co1s} == 0) ? "" : ((\text{co1a} == 1) ? "" : \text{co1a}))\} \%v\{((\text{co1s} == 0) ? "" : "x")\} = \%v\{(\text{sign1} * \text{magnitude1})\}$

$10y + x = 10x + y \%v\{((\text{sign2} == 0) ? "" : ((\text{sign2} == 1) ? "+" : "-"))\} \%v\{((\text{sign2} == 0) ? "" : \text{magnitude2})\}$

$10y + x - y - 10x = 10x + y \%v\{((\text{sign2} == 0) ? "" : ((\text{sign2} == 1) ? "+" : "-"))\} \%v\{((\text{sign2} == 0) ? "" : \text{magnitude2})\} - y - 10x$

$(9y - 9x) / 9 = \%v\{(\text{sign2} * \text{magnitude2})\} / 9$

$y - x = \%v\{(\text{sign2} * \text{magnitude2} / 9)\}$

$\%v\{(((\text{-co2s} * \text{co2a}) == 1) ? "" : "Next, multiply the ")\} \%v\{(((\text{-co2s} * \text{co2a}) == 1) ? "" : "second equation")\} \%v\{(((\text{-co2s} * \text{co2a}) == 1) ? "" : " by the ")\} \%v\{(((\text{-co2s} * \text{co2a}) == 1) ? "" : "opposite of the y coefficient of the first equation.")\}$

$$\begin{aligned} & \%v\{((-co2s * co2a) == 1) ? "" : "y - x = "\}\%v\{((-co2s * co2a) == 1) ? "" : (sign2 * magnitude2 / 9)\} \\ & \%v\{((-co2s * co2a) == 1) ? "" : "(y - x) * "\}\%v\{((-co2s * co2a) == 1) ? "" : (-co2s * \\ & co2a)\}\%v\{((-co2s * co2a) == 1) ? "" : "="\}\%v\{((-co2s * co2a) == 1) ? "" : (sign2 * magnitude2 / \\ & 9)\}\%v\{((-co2s * co2a) == 1) ? "" : " * "\}\%v\{((-co2s * co2a) == 1) ? "" : (-co2s * co2a)\} \\ & \%v\{((-co2s * co2a) == 1) ? "" : ((co2s == 1) ? "-" : "")\}\%v\{((-co2s * co2a) == 1) ? "" : ((co2a == 1) \\ & ? "" : co2a)\}\%v\{((-co2s * co2a) == 1) ? "" : "y"\}\%v\{((-co2s * co2a) == 1) ? "" : ((co2s == 1) ? "+" \\ & : "-" - ")\}\%v\{((-co2s * co2a) == 1) ? "" : ((co2a == 1) ? "" : co2a)\}\%v\{((-co2s * co2a) == 1) ? "" : \\ & "x = "\}\%v\{((-co2s * co2a) == 1) ? "" : (sign2 * magnitude2 * -co2s * co2a / 9)\} \end{aligned}$$

Now add the two equations and solve for x.

$$\begin{aligned} & \%v\{((co2s == 1) ? "" : "-")\}\%v\{((co2a == 1) ? "" : co2a)\}y\%v\{((co1s == 1) ? "+" : "-")\}\%v\{((co1a \\ & == 1) ? "" : co1a)\}x = \%v\{(sign1 * magnitude1)\} \\ & \%v\{((co2s == 1) ? "-" : "")\}\%v\{((co2a == 1) ? "" : co2a)\}y\%v\{((co2s == 1) ? "+" : "-")\}\%v\{((co2a \\ & == 1) ? "" : co2a)\}x = \%v\{((sign2 * co2s) == 1) ? "-" : ""\}\%v\{(magnitude2 * co2a / 9)\} \end{aligned}$$

$$\begin{aligned} & \%v\{((co2s == 1) ? "" : "-")\}\%v\{((co2a == 1) ? "" : co2a)\}y\%v\{((co1s == 1) ? "+" : "-")\}\%v\{((co1a \\ & == 1) ? "" : co1a)\}x \%v\{((co2s == 1) ? "-" : "+" )\}\%v\{((co2a == 1) ? "" : co2a)\}y\%v\{((co2s == 1) ? \\ & "+" : "-" - ")\}\%v\{((co2a == 1) ? "" : co2a)\}x = \%v\{(sign1 * magnitude1)\}\%v\{((sign2 * co2s) == 1) ? \\ & - : "+" )\}\%v\{(magnitude2 * co2a / 9)\} \\ & \%v\{((co3s == 1) ? "" : "-")\}\%v\{((co3a == 1) ? "" : co3a)\}x = \%v\{magnitude3\} \\ & \%v\{((co3 == 1) ? "" : co3)\}\%v\{((co3 == 1) ? "" : "x")\}\%v\{((co3 == 1) ? "" : "/" )\}\%v\{((co3 == 1) ? \\ & "" : co3)\}\%v\{((co3 == 1) ? "" : "=")\}\%v\{((co3 == 1) ? "" : magnitude3)\}\%v\{((co3 == 1) ? "" : "/" \\ & )\}\%v\{((co3 == 1) ? "" : co3)\} \\ & \%v\{((co3 == 1) ? "" : "x = "\}\%v\{((co3 == 1) ? "" : tens)\} \end{aligned}$$

Now we have found the value of x. Because x represents the tens digit of the number we are trying to find, we know that the tens digit is  $\%v\{\text{tens}\}$

- The final step is to find the ones digit. Earlier, we found the equation

$$y - x = \%v\{(sign2 * magnitude2 / 9)\}$$

Also, we know the value of x is  $\%v\{\text{tens}\}$

Substitute  $\%v\{\text{tens}\}$  for x in the equation

$$y - x = \%v\{(sign2 * magnitude2 / 9)\}$$

$$y - (\%v\{\text{tens}\}) = \%v\{(sign2 * magnitude2 / 9)\}$$

$$\begin{aligned} & y\%v\{((co3s * sign3 == 1) ? "-" : "+" )\}\%v\{(sign3 * magnitude3 / co3a)\}\%v\{((co3s * sign3 == 1) ? \\ & "+" : "-" - ")\}\%v\{(sign3 * magnitude3 / co3a)\} = \%v\{(sign2 * magnitude2 / 9)\}\%v\{((co3s * sign3 == 1) ? \\ & "+" : "-" - ")\}\%v\{(sign3 * magnitude3 / co3a)\} \\ & y = \%v\{\text{ones}\} \end{aligned}$$

We now know the values of both unknowns. Because x represents the tens digit and y represents the ones digit, the number is  $\%v\{\text{answer}\}$ .

Please type  $\%v\{\text{answer}\}$

#### Hints:

- There are no hints for this problem. The next hint will reveal the answer.
- The number is  $\%v\{\text{answer}\}$

Please type  $\%v\{\text{answer}\}$

#### 8) Assistment #68900 "68900 - 62904 - Systems of Equations - The Digits Problem (Hints)"

Twice the tens digit of a positive, two-digit integer is 16 greater than the ones digit. Reversing the digits decreases the number by 63. What is the number?

**Algebra:**

✓ 92

**Hints:**

- There are no hints for this problem. The next hint will reveal the answer.
- The number is 92

Please type 92

**Hints:**

- The first step is to use the problem to write a system of equations. Let the variable  $x$  represent the tens digit and the variable  $y$  represent the ones digit.

Twice the **tens digit** of a positive, two-digit integer is 16 greater than the **ones digit**.

$$2x = y + 16$$

Reversing the **digits** decreases the number by **63**.

$$10y + x = 10x + y - 63$$

We now have a system of equations with two variables and two equations.

- The next step is to solve the system of equations. First, simplify the equations and combine terms.

$$2x = y + 16$$

$$2x - y = y + 16 - y$$

$$-y + 2x = 16$$

$$10y + x = 10x + y - 63$$

$$10y + x - y - 10x = 10x + y - 63 - y - 10x$$

$$(9y - 9x) / 9 = -63 / 9$$

$$y - x = -7$$

Now add the two equations and solve for  $x$ .

$$-y + 2x = 16$$

$$y - x = -7$$

$$-y + 2x + y - x = 16 - 7$$

$$x = 9$$

Now we have found the value of  $x$ . Because  $x$  represents the tens digit of the number we are trying to find, we know that the tens digit is 9

- The final step is to find the ones digit. Earlier, we found the equation

$$y - x = -7$$

Also, we know the value of  $x$  is 9

Substitute 9 for  $x$  in the equation

$$y - x = -7$$

$$y - (9) = -7$$

$$y - 9 + 9 = -7 + 9$$

$$y = 2$$

We now know the values of both unknowns. Because  $x$  represents the tens digit and  $y$  represents the ones digit, the number is 92.

Please type 92

### 9) Assistment #63550 "63550 - Systems of Equations - The Age Problem (Hints)"

$\%v\{\text{name}\}$ 's  $\%v\{((\text{parent} == 0) ? \text{"father"} : \text{"mother"})\}$  is  $\%v\{\text{now}\}$  times as old as  $\%v\{\text{name}\}$ .  $\%v\{\text{time}\}$  years from now,  $\%v\{\text{name}\}$  will be  $1/\%v\{\text{later}\}$  as old as  $\%v\{\text{gender}\} \%v\{((\text{parent} == 0) ? \text{"father"} : \text{"mother"})\}$ . How old is  $\%v\{\text{name}\}$ 's  $\%v\{((\text{parent} == 0) ? \text{"father"} : \text{"mother"})\}$ ?

#### Algebra:

✓  $\%v\{\text{age2}\}$

✗  $\%v\{\text{age1}\}$

#### Hints:

- The first step is to write a system of equations using information given in the problem. Let the variable  $\%v\{\text{var}\}$  represent  $\%v\{\text{name}\}$ 's age and the variable  $\%v\{((\text{parent} == 0) ? \text{"f"} : \text{"m"})\}$  represent  $\%v\{\text{gender}\} \%v\{((\text{parent} == 0) ? \text{"father"} : \text{"mother"})\}$ 's age.

$\%v\{\text{name}\}$ 's  $\%v\{((\text{parent} == 0) ? \text{"father"} : \text{"mother"})\}$  is  $\%v\{\text{now}\}$  times as old as  $\%v\{\text{name}\}$ .

$$\%v\{((\text{parent} == 0) ? \text{"f"} : \text{"m"})\} = \%v\{\text{now}\} \%v\{\text{var}\}$$

$\%v\{\text{time}\}$  years from now,  $\%v\{\text{name}\}$  will be  $1/\%v\{\text{later}\}$  as old as  $\%v\{\text{gender}\} \%v\{((\text{parent} == 0) ? \text{"father"} : \text{"mother"})\}$ .

$$\%v\{\text{var}\} + \%v\{\text{time}\} = (1/\%v\{\text{later}\})(\%v\{((\text{parent} == 0) ? \text{"f"} : \text{"m"})\} + \%v\{\text{time}\})$$

Now we have two equations and two variables, so we can solve the system of equations for  $\%v\{\text{name}\}$ 's  $\%v\{((\text{parent} == 0) ? \text{"father"} : \text{"mother"})\}$ 's age.

- We have to solve the system of equations

$$\%v\{((\text{parent} == 0) ? \text{"f"} : \text{"m"})\} = \%v\{\text{now}\} \%v\{\text{var}\}$$

$$\%v\{\text{var}\} + \%v\{\text{time}\} = (1/\%v\{\text{later}\})(\%v\{((\text{parent} == 0) ? \text{"f"} : \text{"m"})\} + \%v\{\text{time}\})$$

Because the first equation gives us  $\%v\{((\text{parent} == 0) ? \text{"f"} : \text{"m"})\}$  in terms of  $\%v\{\text{var}\}$ , substitution is probably the simplest method to solve the system of equations.

Substitute  $\%v\{\text{now}\} \%v\{\text{var}\}$  for  $\%v\{((\text{parent} == 0) ? \text{"f"} : \text{"m"})\}$  in the second equation.

$$\%v\{\text{var}\} + \%v\{\text{time}\} = (1/\%v\{\text{later}\})(\%v\{((\text{parent} == 0) ? \text{"f"} : \text{"m"})\} + \%v\{\text{time}\})$$

$$\%v\{\text{var}\} + \%v\{\text{time}\} = (1/\%v\{\text{later}\})(\%v\{\text{now}\} \%v\{\text{var}\} + \%v\{\text{time}\})$$

Now we have one equation with one variable, and we can solve for  $\%v\{\text{var}\}$ .

$$\%v\{\text{var}\} + \%v\{\text{time}\} = (1/\%v\{\text{later}\})(\%v\{\text{now}\} \%v\{\text{var}\} + \%v\{\text{time}\})$$

$$(\%v\{\text{var}\} + \%v\{\text{time}\}) * \%v\{\text{later}\} = (1/\%v\{\text{later}\})(\%v\{\text{now}\} \%v\{\text{var}\} + \%v\{\text{time}\}) * \%v\{\text{later}\}$$

$$\%v\{\text{later}\} \%v\{\text{var}\} + \%v\{\text{later} * \text{time}\} = \%v\{\text{now}\} \%v\{\text{var}\} + \%v\{\text{time}\}$$

$$\%v\{\text{later}\} \%v\{\text{var}\} + \%v\{\text{later} * \text{time}\} - \%v\{\text{now}\} \%v\{\text{var}\} - \%v\{\text{later} * \text{time}\} = \%v\{\text{now}\} \%v\{\text{var}\} + \%v\{\text{time}\} - \%v\{\text{now}\} \%v\{\text{var}\} - \%v\{\text{later} * \text{time}\}$$

$$\%v\{\text{later} - \text{now}\} \%v\{\text{var}\} = \%v\{\text{time} - \text{later} * \text{time}\}$$

$$\%v\{\text{later} - \text{now}\} \%v\{\text{var}\} / \%v\{\text{later} - \text{now}\} = \%v\{\text{time} - \text{later} * \text{time}\} / \%v\{\text{later} - \text{now}\}$$

$$\%v\{\text{var}\} = \%v\{\text{age1}\}$$

Because the variable  $\%v\{\text{var}\}$  represents  $\%v\{\text{name}\}$ 's age,  $\%v\{\text{name}\}$  is  $\%v\{\text{age1}\}$  years old.



- The problem is asking for  $\%v\{\text{name}\}$ 's  $\%v\{((\text{parent} == 0) ? \text{"father"} : \text{"mother"})\}$ 's age. Earlier, we found the equation

$$\%v\{((\text{parent} == 0) ? \text{"f"} : \text{"m"})\} = \%v\{\text{now}\}\%v\{\text{var}\}$$

We also know that the value of  $\%v\{\text{var}\}$  is  $\%v\{\text{age1}\}$ .

Substitute the value  $\%v\{\text{age1}\}$  for  $\%v\{\text{var}\}$  in the equation

$$\%v\{((\text{parent} == 0) ? \text{"f"} : \text{"m"})\} = \%v\{\text{now}\}\%v\{\text{var}\}$$

$$\%v\{((\text{parent} == 0) ? \text{"f"} : \text{"m"})\} = \%v\{\text{now}\}(\%v\{\text{age1}\})$$

$$\%v\{((\text{parent} == 0) ? \text{"f"} : \text{"m"})\} = \%v\{\text{age2}\}$$

Because the variable  $\%v\{((\text{parent} == 0) ? \text{"f"} : \text{"m"})\}$  represents  $\%v\{\text{gender}\}$   $\%v\{((\text{parent} == 0) ? \text{"father"} : \text{"mother"})\}$ 's age,  $\%v\{\text{name}\}$ 's  $\%v\{((\text{parent} == 0) ? \text{"father"} : \text{"mother"})\}$  is  $\%v\{\text{age2}\}$  years old.

Please type  $\%v\{\text{age2}\}$

#### Hints:

- There are no hints for this problem. The next hint will reveal the answer.
- $\%v\{\text{name}\}$ 's  $\%v\{((\text{parent} == 0) ? \text{"father"} : \text{"mother"})\}$  age is  $\%v\{\text{age2}\}$

Please type  $\%v\{\text{age2}\}$

#### 10) Assistment #68921 "68921 - 63550 - Systems of Equations - The Age Problem (Hints)"

Karen's mother is 11 times as old as Karen. 12 years from now, Karen will be 1/3 as old as her mother. How old is Karen's mother?

#### Algebra:

✓ 33

✗ 3

#### Hints:

- There are no hints for this problem. The next hint will reveal the answer.
- Karen's mother age is 33

Please type 33

#### Hints:

- The first step is to write a system of equations using information given in the problem. Let the variable  $k$  represent Karen's age and the variable  $m$  represent her mother's age.

Karen's mother is 11 times as old as Karen.

$$m = 11k$$

12 years from now, Karen will be 1/3 as old as her mother.

$$k + 12 = (1/3)(m + 12)$$

Now we have two equations and two variables, so we can solve the system of equations for Karen's mother's age.



- We have to solve the system of equations

$$m = 11k$$

$$k + 12 = (1/3)(m + 12)$$

Because the first equation gives us  $m$  in terms of  $k$ , substitution is probably the simplest method to solve the system of equations.

Substitute  $11k$  for  $m$  in the second equation.

$$k + 12 = (1/3)(m + 12)$$

$$k + 12 = (1/3)(11k + 12)$$

Now we have one equation with one variable, and we can solve for  $k$ .

$$k + 12 = (1/3)(11k + 12)$$

$$(k + 12) * 3 = (1/3)(11k + 12) * 3$$

$$3k + 36 = 11k + 12$$

$$3k + 36 - 11k - 36 = 11k + 12 - 11k - 36$$

$$-8k = -24$$

$$-8k / -8 = -24 / -8$$

$$k = 3$$

Because the variable  $k$  represents Karen's age, Karen is 3 years old.

- The problem is asking for Karen's mother's age. Earlier, we found the equation

$$m = 11k$$

We also know that the value of  $k$  is 3.

Substitute the value 3 for  $k$  in the equation

$$m = 11k$$

$$m = 11(3)$$

$$m = 33$$

Because the variable  $m$  represents her mother's age, Karen's mother is 33 years old.

Please type 33

### 11) Assistment #56572 "56572 - Systems of Equations - The Produce Problem (Hints)"

A)  $\%v\{\text{name1}\}$  bought  $\%v\{\text{num1}\}$   $\%v\{\text{item1}\}$ s and  $\%v\{\text{num2}\}$   $\%v\{\text{item2}\}$ s at the local supermarket for a total of  $\%v\{\text{total1}\}$   $\%v\{\text{((disp1 == 0) ? "" : "0")}\}$

$\%v\{\text{name2}\}$  bought  $\%v\{\text{num3}\}$   $\%v\{\text{item1}\}$ s and  $\%v\{\text{num4}\}$   $\%v\{\text{item2}\}$ s at the same store for a total of  $\%v\{\text{total2}\}$   $\%v\{\text{((disp2 == 0) ? "" : "0")}\}$

How much does one  $\%v\{\text{item1}\}$  cost?

**Algebra:**

  $\%v\{\text{cost1}\}$

  $\%v\{\text{cost2}\}$

**Hints:**

- There are no hints for this problem. The next hint will reveal the answer.
- The price of one  $\%v\{\text{item1}\}$  is  $\%v\{\text{cost1}\}$   $\%v\{\text{((disp3 == 0) ? "" : "0")}\}$

Please type  $\%v\{\text{cost1}\}$

### Hints:

- First, use the information given in the problem to write two equations.

$\%v\{\text{name1}\}$  bought  $\%v\{\text{num1}\}$   $\%v\{\text{item1}\}$ s and  $\%v\{\text{num2}\}$   $\%v\{\text{item2}\}$ s at the local supermarket for a total of  $\$ \%v\{\text{total1}\}$ . This gives us the equation

$$\%v\{\text{num1}\}\%v\{\text{var1}\} + \%v\{\text{num2}\}\%v\{\text{var2}\} = \%v\{\text{total1}\}$$

In this equation,  $\%v\{\text{var1}\}$  represents the price of one  $\%v\{\text{item1}\}$  and  $\%v\{\text{var2}\}$  represents the price of one  $\%v\{\text{item2}\}$ .

$\%v\{\text{name2}\}$  bought  $\%v\{\text{num3}\}$   $\%v\{\text{item1}\}$ s and  $\%v\{\text{num4}\}$   $\%v\{\text{item2}\}$ s at the same store for a total of  $\$ \%v\{\text{total2}\}$ . This gives us the equation

$$\%v\{\text{num3}\}\%v\{\text{var1}\} + \%v\{\text{num4}\}\%v\{\text{var2}\} = \%v\{\text{total2}\}$$

Again,  $\%v\{\text{var1}\}$  represents the price of one  $\%v\{\text{item1}\}$  and  $\%v\{\text{var2}\}$  represents the price of one  $\%v\{\text{item2}\}$ .

- $\%v\{\text{num1}\}\%v\{\text{var1}\} + \%v\{\text{num2}\}\%v\{\text{var2}\} = \%v\{\text{total1}\}$   
 $\%v\{\text{num3}\}\%v\{\text{var1}\} + \%v\{\text{num4}\}\%v\{\text{var2}\} = \%v\{\text{total2}\}$

Now you have a system of equations. The problem asks you to find the price of one  $\%v\{\text{item1}\}$ . In your equations, the variable  $\%v\{\text{var1}\}$  represents the price of one  $\%v\{\text{item1}\}$ , so all you have to do is solve the system of equations for the variable  $\%v\{\text{var1}\}$ .

- There are many ways to solve a system of equations. Here is one example of a method for solving a system of equations.

### 1. Solve both equations for $\%v\{\text{var2}\}$ in terms of $\%v\{\text{var1}\}$ .

$$\%v\{\text{num1}\}\%v\{\text{var1}\} + \%v\{\text{num2}\}\%v\{\text{var2}\} = \%v\{\text{total1}\}$$

$$\%v\{\text{num1}\}\%v\{\text{var1}\} + \%v\{\text{num2}\}\%v\{\text{var2}\} - \%v\{\text{num1}\}\%v\{\text{var1}\} = \%v\{\text{total1}\} - \%v\{\text{num1}\}\%v\{\text{var1}\}$$

$$\frac{\%v\{\text{num2}\}\%v\{\text{var2}\}}{\%v\{\text{num2}\}} = \frac{\%v\{\text{total1}\} - \%v\{\text{num1}\}\%v\{\text{var1}\}}{\%v\{\text{num2}\}}$$

$$\%v\{\text{var2}\} = \frac{\%v\{\text{total1}\} - \%v\{\text{num1}\}\%v\{\text{var1}\}}{\%v\{\text{num2}\}}$$

$$\%v\{\text{num3}\}\%v\{\text{var1}\} + \%v\{\text{num4}\}\%v\{\text{var2}\} = \%v\{\text{total2}\}$$

$$\%v\{\text{num3}\}\%v\{\text{var1}\} + \%v\{\text{num4}\}\%v\{\text{var2}\} - \%v\{\text{num3}\}\%v\{\text{var1}\} = \%v\{\text{total2}\} - \%v\{\text{num3}\}\%v\{\text{var1}\}$$

$$\frac{\%v\{\text{num4}\}\%v\{\text{var2}\}}{\%v\{\text{num4}\}} = \frac{\%v\{\text{total2}\} - \%v\{\text{num3}\}\%v\{\text{var1}\}}{\%v\{\text{num4}\}}$$

$$\%v\{\text{var2}\} = \frac{\%v\{\text{total2}\} - \%v\{\text{num3}\}\%v\{\text{var1}\}}{\%v\{\text{num4}\}}$$

**2. Set the expressions equal to each other and solve for  $\%v\{\text{var1}\}$ .** *Because they both equal  $\%v\{\text{var2}\}$ , they must be equal to each other.*

$$\%v\{\text{var2}\} = \frac{\%v\{\text{total1}\} - \%v\{\text{num1}\}\%v\{\text{var1}\}}{\%v\{\text{num2}\}}$$

$$\%v\{\text{var2}\} = \frac{\%v\{\text{total2}\} - \%v\{\text{num3}\}\%v\{\text{var1}\}}{\%v\{\text{num4}\}}$$

$$\frac{\%v\{\text{total1}\} - \%v\{\text{num1}\}\%v\{\text{var1}\}}{\%v\{\text{num2}\}} = \frac{\%v\{\text{total2}\} - \%v\{\text{num3}\}\%v\{\text{var1}\}}{\%v\{\text{num4}\}}$$

$$\frac{\%v\{\text{total1}\} - \%v\{\text{num1}\}\%v\{\text{var1}\}}{\%v\{\text{num2}\}} \cdot \frac{\%v\{\text{num2}\}}{\%v\{\text{num4}\}} = \frac{\%v\{\text{total2}\} - \%v\{\text{num3}\}\%v\{\text{var1}\}}{\%v\{\text{num4}\}} \cdot \frac{\%v\{\text{num2}\}}{\%v\{\text{num4}\}}$$

$$\%v\{(\text{total1} * \text{num4})\} - \%v\{(\text{num1} * \text{num4})\}\%v\{\text{var1}\} = \%v\{(\text{total2} * \text{num2})\} - \%v\{(\text{num3} * \text{num2})\}\%v\{\text{var1}\}$$

$$\%v\{(\text{total1} * \text{num4})\} - \%v\{(\text{num1} * \text{num4})\}\%v\{\text{var1}\} + \%v\{(\text{num3} * \text{num2})\}\%v\{\text{var1}\} = \%v\{(\text{total2} * \text{num2})\} - \%v\{(\text{num3} * \text{num2})\}\%v\{\text{var1}\} + \%v\{(\text{num3} * \text{num2})\}\%v\{\text{var1}\}$$

$$\%v\{(total1 * num4)\} \%v\{((snum == 1) ? "+" : "-")\} \%v\{rnum\} \%v\{var1\} = \%v\{(total2 * num2)\}$$

$$\%v\{(total1 * num4)\} \%v\{((snum == 1) ? "+" : "-")\} \%v\{rnum\} \%v\{var1\} - \%v\{(total1 * num4)\} = \%v\{(total2 * num2)\} - \%v\{(total1 * num4)\}$$

$$\%v\{(num2 * num3 - num1 * num4)\} \%v\{var1\} = \%v\{(total2 * num2 - total1 * num4)\}$$

$$\frac{\%v\{(num2 * num3 - num1 * num4)\} \%v\{var1\}}{\%v\{(num2 * num3 - num1 * num4)\}} = \frac{\%v\{(total2 * num2 - total1 * num4)\}}{\%v\{(num2 * num3 - num1 * num4)\}}$$

$$\%v\{var1\} = \frac{\%v\{(total2 * num2 - total1 * num4)\}}{\%v\{(num2 * num3 - num1 * num4)\}} = \%v\{cost1\}$$

- The value of  $\%v\{var1\}$  is  $\%v\{cost1\}$ . Because  $\%v\{var1\}$  represents the price of one  $\%v\{item1\}$ , one  $\%v\{item1\}$  costs  $\$ \%v\{cost1\} \%v\{((disp3 == 0) ? "" : "0")\}$

Please type  $\%v\{cost1\}$

**B) How much does one  $\%v\{item2\}$  cost?**

**Algebra:**

✓  $\%v\{cost2\}$

✗  $\%v\{cost1\}$

**Hints:**

- Now that you know the cost of each  $\%v\{item1\}$ , you can substitute that into either of the equations you found earlier to find the cost of each  $\%v\{item2\}$ .
- Here, we substitute the value  $\%v\{cost1\}$  for  $\%v\{var1\}$  in the first equation and solve for  $\%v\{var2\}$ .

$$\%v\{num1\} \%v\{var1\} + \%v\{num2\} \%v\{var2\} = \%v\{total1\}$$

$$\%v\{num1\} (\%v\{cost1\}) + \%v\{num2\} \%v\{var2\} = \%v\{total1\}$$

$$\%v\{(num1 * cost1)\} + \%v\{num2\} \%v\{var2\} = \%v\{total1\}$$

$$\%v\{(num1 * cost1)\} + \%v\{num2\} \%v\{var2\} - \%v\{(num1 * cost1)\} = \%v\{total1\} - \%v\{(num1 * cost1)\}$$

$$\%v\{num2\} \%v\{var2\} = \%v\{(total1 - num1 * cost1)\}$$

$$\frac{\%v\{\text{num2}\}\%v\{\text{var2}\}}{\%v\{\text{num2}\}} = \frac{\%v\{(\text{total1} - \text{num1} * \text{cost1})\}}{\%v\{\text{num2}\}}$$

$$\%v\{\text{var2}\} = \frac{\%v\{(\text{total1} - \text{num1} * \text{cost1})\}}{\%v\{\text{num2}\}} = \%v\{\text{cost2}\}$$

- The value of  $\%v\{\text{var2}\}$  is  $\%v\{\text{cost2}\}$ . Because  $\%v\{\text{var2}\}$  represents the price of one  $\%v\{\text{item2}\}$ , one  $\%v\{\text{item2}\}$  costs  $\$ \%v\{\text{cost2}\}$   $\%v\{((\text{disp4} == 0) ? "" : "0")\}$

Please type  $\%v\{\text{cost2}\}$

**Hints:**

- There are no hints for this problem. The next hint will reveal the answer.
- The price of one  $\%v\{\text{item2}\}$  is  $\$ \%v\{\text{cost2}\}$   $\%v\{((\text{disp4} == 0) ? "" : "0")\}$

Please type  $\%v\{\text{cost2}\}$

**12) Assistment #68890 "68890 - 56572 - Systems of Equations - The Produce Problem (Hints)"**

A) Ursula bought 8 Apricots and 10 Pineapples at the local supermarket for a total of \$48

Bernat bought 10 Apricots and 10 Pineapples at the same store for a total of \$49

How much does one Apricot cost?

**Algebra:**

✓ 0.5

✗ 4.4

**Hints:**

- First, use the information given in the problem to write two equations.

Ursula bought 8 **Apricots** and 10 **Pineapples** at the local supermarket for a total of \$48. This gives us the equation

$$8A + 10P = 48$$

In this equation, **A** represents the price of one **Apricot** and **P** represents the price of one **Pineapple**.

Bernat bought 10 **Apricots** and 10 **Pineapples** at the same store for a total of \$49. This gives us the equation

$$10A + 10P = 49$$

Again, **A** represents the price of one **Apricot** and **P** represents the price of one **Pineapple**.

- $8A + 10P = 48$   
 $10A + 10P = 49$

Now you have a system of equations. The problem asks you to find the price of one **Apricot**. In your equations, the variable **A** represents the price of one **Apricot**, so all you have to do is solve the system of equations for the variable **A**.

- There are many ways to solve a system of equations. Here is one example of a method for solving a system of equations.

### 1. Solve both equations for **P** in terms of **A**.

$$8A + 10P = 48$$

$$8A + 10P - 8A = 48 - 8A$$

$$\frac{10P}{10} = \frac{48 - 8A}{10}$$

$$P = \frac{48 - 8A}{10}$$

$$10A + 10P = 49$$

$$10A + 10P - 10A = 49 - 10A$$

$$\frac{10P}{10} = \frac{49 - 10A}{10}$$

$$P = \frac{49 - 10A}{10}$$

**2. Set the expressions equal to each other and solve for **A**.** *Because they both equal **P**, they must be equal to each other.*

$$P = \frac{48 - 8A}{10}$$

$$P = \frac{49 - 10A}{10}$$

10

$$\frac{48 - 8A}{10} = \frac{49 - 10A}{10}$$

$$\frac{48 - 8A}{10} * 10 * 10 = \frac{49 - 10A}{10} * 10 * 10$$

$$480 - 80A = 490 - 100A$$

$$480 - 80A + 100A = 490 - 100A + 100A$$

$$480 + 20A = 490$$

$$480 + 20A - 480 = 490 - 480$$

$$20A = 10$$

$$\frac{20A}{20} = \frac{10}{20}$$

$$A = \frac{10}{20} = 0.5$$

- The value of A is 0.5. Because A represents the price of one Apricot, one Apricot costs \$0.50

Please type 0.5

**Hints:**

- There are no hints for this problem. The next hint will reveal the answer.
- The price of one Apricot is \$0.50

Please type 0.5

**B)** How much does one Pineapple cost?

**Algebra:**

✓ 4.4

✗ 0.5

**Hints:**

- There are no hints for this problem. The next hint will reveal the answer.
- The price of one Pineapple is \$4.40

Please type 4.4

**Hints:**

- Now that you know the cost of each Apricot, you can substitute that into either of the equations you found earlier to find the cost of each Pineapple.
- Here, we substitute the value 0.5 for A in the first equation and solve for P.

$$8A + 10P = 48$$

$$8(0.5) + 10P = 48$$

$$4 + 10P = 48$$

$$4 + 10P - 4 = 48 - 4$$

$$10P = 44$$

$$\frac{10P}{10} = \frac{44}{10}$$

$$P = \frac{44}{10} = 4.4$$

- The value of P is 4.4. Because P represents the price of one Pineapple, one Pineapple costs \$4.40

Please type 4.4

---