

April 2013

The Rhetoric of Trade Journals: An Analysis of Chemical Engineering Professionalization in Print

Melanie Elizabeth Laberge
Worcester Polytechnic Institute

Follow this and additional works at: <https://digitalcommons.wpi.edu/mqp-all>

Repository Citation

Laberge, M. E. (2013). *The Rhetoric of Trade Journals: An Analysis of Chemical Engineering Professionalization in Print*. Retrieved from <https://digitalcommons.wpi.edu/mqp-all/1045>

This Unrestricted is brought to you for free and open access by the Major Qualifying Projects at Digital WPI. It has been accepted for inclusion in Major Qualifying Projects (All Years) by an authorized administrator of Digital WPI. For more information, please contact digitalwpi@wpi.edu.

**The Rhetoric of Trade Journals:
An Analysis of Chemical Engineering Professionalization in Print**



A Major Qualifying Project Report
Submitted to the Faculty of
WORCESTER POLYTECHNIC INSTITUTE
In partial fulfillment of the requirements for the
Degree of Bachelor of Science, Professional Writing

Submitted By:
Melanie Laberge

Advised By:
Professor Jennifer deWinter

Submission Date:
April 25, 2013

Email:
M.e.laberge09@gmail.com

Acknowledgements

I would like to acknowledge the following people for their help with this work:

- Cynthia Mascone, for giving me the opportunity to write for CEP, and guiding me through the process
- Laura Hanlan and Christine Drew, without whom my literature review would not be as complete
- Nicholas DeMarinis & Professor Jennifer deWinter, for coding article content, & Jotham Edwards, for coding article stylistics
- Gareth Hatch, Jack Lifton, Professor Andries Meijerink, Karl Gschneider, Professor Roderick Eggert, Tony Mariano Jr. & Sr., and Ivor Harris for graciously participating in the interviews for the article
- Professor Jennifer deWinter, without whom my entire academic career would have taken a very different path, and therefore, this project, and all the opportunities leading up to it and following it, would not have been possible.

Abstract

The goal of this research was to conduct a generic study of chemical engineering trade journals in order to inform my writing process for an article for *Chemical Engineering Progress*. However, no previous systematic and replicable way to study trade journals was present in the literature. Therefore, the aims of my project shifted from production to analysis as I needed to fill this gap before I could proceed with the article. To conduct this research, I examined previous work in the academic and popular genres of scientific communication in order to define trade journals in relation to these two other genres of scientific communication. I then used this analysis and analysis of generic studies to design and conduct a systematic and replicable inductive study of 9 trade journal articles through the use of coding sheets. This study allowed me to classify the structural features of this genre. This MQP contains the highlights of my research in the academic and popular genres, the methods and research that supported my study, the results of the study, and how those results guided my writing process.

From my analysis, I found that trade journals incorporated elements of not only the academic and popular genres, but also some features of the scientific textbook. I argued that this inclusion of the third genre was important given the instructional tone of these pieces, which overlapped with that of the textbook genre but in a more active and direct way. This tone was appropriate due to the higher stakes situations found in industry as opposed to in the classroom, where this technical work has realistic consequences. Further, there were two main categories of articles: highly technical, which exhibited more features of the academic scientific genre, such as nomenclature tables, graphs, equations, and citations; and overview; which displayed more features of the popular scientific genre, such as expert quotations, metaphors, pictures, and a

progressive outlook. My findings on the overview article, particularly relating to use of expert quotations, metaphors, progressive tone, presentation of challenges, and emphasis on the role of chemical engineers, were used in my article writing process.

Table of Contents

Acknowledgements	ii
Abstract	iii
List of Figures	vii
List of Tables	vii
1 : Chemical Engineering Trade Journals:	1
Between the Academic and Popular Genres of Scientific Communication	1
2 : The Genres of Knowledge Building & Dissemination:	5
Academic Journals, Science Writing for the Public, and Trade Journals.....	5
Why Are Trade Journals Understudied?	7
Academic Scientific Journals	7
The Evolution of Accountability.....	7
Academic Gatekeeping: Peer Review	9
Popular Scientific Newspaper	11
Tested and True Form.....	11
An Uneasy Relationship: Scientists & Journalists	12
3 : Generic Criticism: Theories and Methods.....	15
Theories of Genre	16
Literary Theories of Genre	16
Rhetorical Theories of Genre	18
Developing the Method.....	23
Choosing a Corpus	24
4 : Characterizing the Form of the Chemical Engineering Trade Journal.....	27
Credibility Features: The Relationship Between Audiences & Authors	28
Generic Features.....	30
Academic Features	30
Popular Features.....	37
Textbook Features	40
Industrial Features	44
Author Credibility	45
Broad Concerns of Industry	48

Professional Networking.....	50
Conclusions.....	51
From Genre Analysis to Article Development	51
Future Work.....	54
Works Cited	56
Appendix A: Coding Sheets.....	61
Appendix B: Conference Poster	70
Appendix C: Article Outline	71

List of Figures

Figure 1: A Continuum of Genres of Scientific Communication: Academic to Popular	5
Figure 2: A Typical Rhetorical Triangle	6
Figure 3: Academic Features in a Trade Journal: Nomenclature Table	31
Figure 4: Academic Features in a Trade Journal: Graphs & Equations	32
Figure 5: Academic Features in Trade Journals: Derivation.....	34
Figure 6: Academic Features in Trade Journal Articles: Citations: Highly Technical Article	35
Figure 7: Academic Features in a Trade Journal: Citations: Overview Article	36
Figure 8: Popular Features in a Trade Journal Article: Pictures & Metaphors.....	38
Figure 9: Textbook Features in a Trade Journal Article: Textbook Diagrams	40
Figure 10: Textbook Example with Figure	42
Figure 11: Textbook Features in a Trade Journal: Instructional Examples	43
Figure 12: Credibility Features: Author Biographies.....	45
Figure 13: Credibility Features: Expert Quotations Bios	47
Figure 14: Stylistics Coding Sheet	61
Figure 15: Overall Coding Sheet	62
Figure 16: Detailed Coding Sheet (5 pages).....	63
Figure 17: Image Coding Sheet (2 pages)	68
Figure 18: Conference Poster	70

List of Tables

Table 1: Corpus Selection Pros & Cons	24
---	----

1 : Chemical Engineering Trade Journals: Between the Academic and Popular Genres of Scientific Communication

In the spring of 2012, I was tasked to write an article for *Chemical Engineering Progress* (CEP), a chemical engineering trade journal published by the American Institute of Chemical Engineers (AIChE). The purpose of this article was to provide readers of the magazine with some background material on rare earth elements and update them on the newest applications and challenges of this technology. I first contacted Cynthia Mascone, Editor-in-Chief of CEP, to determine the publication's readership. I then conducted research to determine what has already been written about trade journals, and discovered a gap. While academic and popular genres of scientific communication have been extensively studied, remarkably little has been discussed about trade journals, and chemical engineering trade journals in particular.

Chemical engineering trade journals discuss practical process and business concepts related to the chemical industry. These publications serve multiple of audiences, including practicing chemical engineers, academics studying chemical processes, and students aspiring to join the chemical industry. For example, news features in chemical engineering trade journals often discuss the most recent discoveries and innovations within chemical processing, such as new Shale gas deposits and the latest developments in drug delivery. This one article type can serve several different audiences by keeping engineers up to date with the constantly evolving chemical industry, providing academics with inspiration for future research, and using exciting, novel examples from industry to appeal to students studying to become chemical engineers. Trade journals also provide continuous education to engineers out of school, offering articles with categories like "Back to Basics"¹ that review fundamental chemical engineering concepts

¹ For an example of this type of article, see "Selecting a Heat Exchanger Shell" in the June 2011 issue of *Chemical Engineering Progress*

and “Reactions and Separations²” that discuss process methods, facilitate equipment selection, and troubleshoot common process equipment. Such articles can also help students learn more about the particulars of this field, and their potential future roles within it.

Although chemical engineering trade journals serve important functions that other scientific communication genres do not, the genre remains vastly understudied. While communication scholars have notably ignored trade journals, they have rigorously studied other genres of scientific communication in academic and popular spheres. In the academic sphere, the experimental article is central to the building of scientific knowledge amongst scientists, and represents communication between academics. Research into experimental articles in academic journals has examined the rigid structure of this content and the gatekeeping provided by peer review (Bazerman, 1988; Chubin & Hackett, 1990; Gopen & Swan, 1990; Mahoney, 1987). In the popular sphere, scientific articles in popular newspapers fulfill scientists’ ethical responsibility to keep the public informed while eliciting public tax dollars to fund future scientific endeavors. This genre represents communication between scientists and the public, often through a journalist that acts as a middleman. Research into popular science articles has examined the common strategies authors use and the difficulties scientists encounter when communicating with the public (Penrose & Katz, 1998; Kreighbaum, 1967; Whitley & Shinn; 1985; de Semir, 2000).

^{2 2} For an example of this type of article, see “Producing Nitrogen via Pressure Swing Adsorption” in the June 2012 issue of Chemical Engineering Progress

Due to the lack of previous research in the genre, characterizing the chemical engineering trade journal was a difficult undertaking. To begin my work, I formulated the following research questions:

- Who reads and writes trade journal articles, and why?
- How does the author, audience, and topic of a trade journal influence its structure?
- As a genre of scientific communication, what, if anything, does the trade journal genre borrow from the academic scientific journal genre and popular scientific articles genre?

I hypothesized that scientific journals were probably the oldest forms of communication, and that trade journals probably evolved from this genre to meet the specific needs of the developing industry. Therefore, I predicted that chemical engineering trade journals would be a synthesis of academic and professional concepts relevant to the chemical industry but written in a style similar to popular scientific communication, as I felt the genre would become more popularized as it grew apart from the academic genre and embraced a different audience.

Based on this hypothesis, I first deductively approached the problem of characterizing the trade journal genre by placing trade journals on a continuum of scientific communication genres. I present the results of this study in Chapter 2, which synthesizes research in the academic and popular spheres of scientific communication to use the differences between each genre's characteristics to later define the genre of trade journals. I then bolstered this definition with an inductive study of nine chemical engineering trade journal articles. I review the procedures I followed to design and conduct this study and the previous research that supported my methods in Chapter 3. I present the results of this inductive study and how these influenced my writing

process for the *Chemical Engineering Progress* article in Chapter 4. I then conclude with some key findings and notes for future work. Appendix A contains the coding sheet templates used in the inductive study. Appendix B contains a picture of the poster of this research, which was presented at the Conference on College Composition & Communication and the Society of Technical Communicators Summit spring of 2013. Appendix C contains an outline of the article to be submitted to the editor of CEP.

2 : The Genres of Knowledge Building & Dissemination: Academic Journals, Science Writing for the Public, and Trade Journals

As stated in Chapter 1, while communication scholars have neglected trade journals, they have rigorously studied other genres of scientific communication in academic and popular spheres. For the purpose of classifying the trade journal, I have placed it on a continuum of scientific communication between the academic; as represented by the experimental article in a scientific journal, and the popular; as represented by the scientific article in a newspaper. Placing trade journals on this continuum built off of my hypothesis that trade journals probably evolved from the older academic scientific genre to meet the specific needs of the developing industry. Therefore, I predicted that chemical engineering trade journals would be a synthesis of academic and professional concepts relevant to the chemical industry but written in a style similar to popular scientific communication, as I felt the genre would become more popularized as it grew apart from the academic genre and embraced a different audience. Using this continuum, reproduced in Figure 1, allowed me to understand the rhetorical underpinnings of this genre by comparing and contrasting these constructs to those of the academic experimental and popular scientific genres.

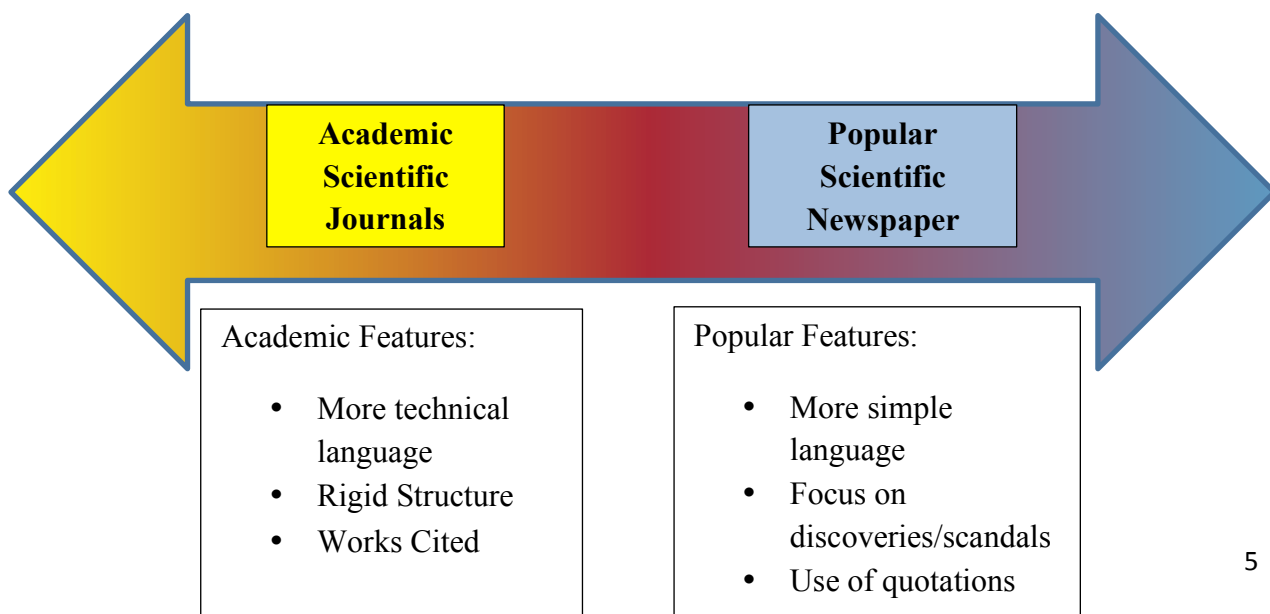

Figure 1: A Continuum of Genres of Scientific Communication: Academic to Popular

I define rhetorical underpinnings as underlying concepts that define each genre and set it apart from other genres. To understand these concepts, I used the rhetorical triangle of audience, author, topic, and purpose, as shown in Figure 2. The rhetorical triangle represents the community that interacts with the text and how the members and motives of that community influence and are influenced by that text's structure.

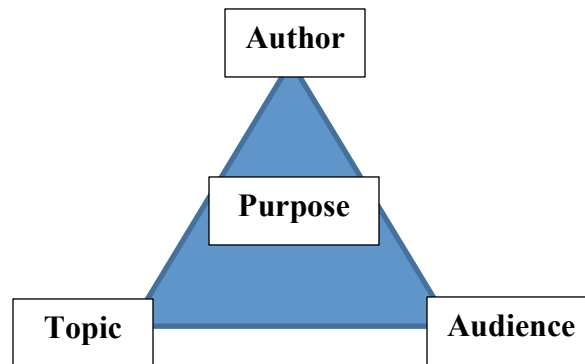

Figure 2: A Typical Rhetorical Triangle

To this structure I added the concepts of history and gatekeeping in order to more fully examine the complex relationships that tie texts to their communities in order to define a genre. Reviewing the history of these genres allowed me to understand how the structure and purposes of these pieces have evolved over time. Examining the gatekeeping, or obstacles to publication, illuminated how these practices influence the types of topics covered and structures used by these genres.

In this chapter I examine why the gap in trade journal research exists. I then begin to fill this gap by summarizing my research in the academic and popular spheres of scientific communication, which later allows me to place trade journals on my scientific communication continuum. To do this, I review the early history of the academic scientific journal and how it has evolved over time. I then discuss the peer review process, why it is in place, and briefly how it functions. On the popular scientific side, I examine the early history of scientific articles in

newspapers and how these basic features are still used today. I also discuss some of the challenges scientists and journalists face in this genre, and how they translate to the discourse.

Why Are Trade Journals Understudied?

Although research on scientific communication has been widespread, trade journals still remain vastly understudied. Examining the types of studies being done, which are mainly in academic and popular spheres, partially explains this gap. From a logical standpoint, it makes sense that academics would study these two areas in particular. Intimately familiar with their own field, communication scholars may find it easier and potentially intriguing to study fellow academics (Elbow, 1991). In addition, communication scholars feel a civic obligation toward communication to the public, which could make studies that seek to improve this communication very important to academics (Penrose & Katz, 1998).

It should be noted that communication scholars have also examined some professional fields of scientific communication, particularly engineering. These studies tend to focus on novices transitioning into these fields, and are often done by teachers hoping to improve writing classes in order to better prepare their own students for such transitions, such as the studies discussed in Dorothy Winsor's *Writing Like an Engineer: A Rhetorical Education*. While most novice engineers will need to compose engineering reports, most will not compose articles in engineering trade journals. Thus, I surmise that this is the reason that little research exists on the social and/or practical processes of trade journals.

Academic Scientific Journals

The Evolution of Accountability

The scientific journal, still circulated today, remains the earliest published form of scientific communication. The Royal Society of London began publishing the first scientific

journal in English, the *Philosophic Transactions of the Royal Society of London*, in 1665.

Charles Bazerman thoroughly studies its evolution in his book, *Shaping Written Knowledge: The Genre and Activity of the Experimental Article in Science*, in which he provides a detailed analysis of his study of a corpus of 100 experimental articles spread over 90 volumes of the journal published between 1665 and 1800. Bazerman chose to focus on experimental articles in order to trace the development of this highly structured genre he finds “close to the heart of the accountability process,” a process Bazerman believes critical to scientific discourse (62).

Accountability represents an important piece of scientific writing. Although often taken as fact, knowledge building comes from consensus (Katz & Penrose, 1998; Shinn & Whitley, 1985). Theories become fact when many scientists converge on consensus. Therefore, scientific writing is artfully written persuasion, with more accountable claims making that writing more effective. Experiments provide scientists with accountability. Interestingly, an experiment was not always based on a claim, but evolved over time from “any made or done thing, to an intentional investigation, to a test of a theory, to finally a proof of, or evidence for, a claim” (Bazerman, 66). This evolution reflects the changing nature of the scientific discipline, and affects the changing structure of the experimental article, as discussed later.

Bazerman reminds his readers, “the importance we attach to experiments is a function of the rise of the experimental article as a favored way of formulating and discussing science” (65). But why choose the structure of the experimental article for this purpose? To answer this question, one must look not only at the texts of the genre, but also the community that develops with it. Bazerman quotes Miller when he defines genre as “a socially recognized, repeated strategy for achieving similar goals in situations socially perceived as being similar” (62). For example, experimental articles maintain a similar structure while each displaying and supporting

a scientist's claims about a different aspect of a natural phenomenon. Repeating the structure of older experimental articles fulfills audience expectations, lending a sort of credibility to the content and making these articles easier to read.

However, simply repeating the structure of past articles was soon not enough to provide accountability for the author's claims, as other scientists would read the work and challenge it. Replicable experiments provided this accountability, as reflected in the growing importance placed on the new detailed methodology section. This more argumentative section showed not only the changing purpose of an experiment, but also a change in the society: in the early days of the journal, scientists replicated experiments in front of the entire society. But as experiments moved into private settings, witness credibility disappeared altogether, and thus, stronger methodologies, which could help the reader envision and replicate the experiments, became the new form of accountability. This form of accountability has persisted in scientific journals to this day, with citations and review of other relevant studies becoming other important sources of accountability that had early starts in *Philosophic Transactions*.

Academic Gatekeeping: Peer Review

Another very important aspect of writing in scientific journals is the pressure to publish. As Ann Penrose and Steven Katz are quick to point out in their book, *Writing in the Sciences: Exploring the Conventions of Scientific Discourse*, “the credit for a scientific discovery is awarded not to the scientist who discovers a phenomenon, but to the scientist who publishes first.” This fundamental characteristic of the scientific community also traces its roots to the Royal Society, which began protecting the rights of its authors in the eighteenth century in the hopes that it would “ensure open communication and the sharing of ideas in science by alleviating the (real) fear of scientists that their ideas or results would be stolen by other

scientists” (7). Today the pressure to publish is stronger than ever, with credit for discoveries not only enhancing one’s credentials, but also securing federal or corporate grants that allow scientists to continue research they would otherwise be unable to continue.

However, the modern scientist faces formidable obstacles to publishing. These come in the form of journal editors and the peer review system. Peer review is the process by which a scientist’s work is sent to and reviewed by other scientists in the same field in order to determine scientific merit. Journal editors use peer review as a tool in their decision process of which articles to publish. After having other researchers attest to the relevance and novelty of a piece of research, the editor will then consider the needs of the journal and expectations of the journal’s readership.

Peer review serves as a type of “quality control” for scientific advancement, and affects not only what is published, but also what is funded (8). Penrose and Katz quote Myers and Seiken when they write about funding allocation: “funding agencies such as the National Science Foundation, the Department of Energy, and the National Institutes of Health evaluate proposals or requests for funding by assigning them for peer review and then, based on recommendations, decide which studies to fund, thus largely determining what kind of research can proceed” (8). Daryl E. Chubin and Edward J. Hackett argue that perhaps peer review limits scientists too much in their book, *Peerless Science: Peer Review and US Science Policy*, stating that “today’s free intellects do not play freely, but instead find themselves tethered to national goals for health, defense, economic competitiveness, and the like,” alluding to college, university, and research institute dependence on federal funding (10). Through the peer review for federal funding, the government largely controls the direction of scientific advancement, often steering it toward what it perceives as “the public good.”

Popular Scientific Newspaper

Tested and True Form

“The public good” is directly tied to another very important type of scientific communication, which I call scientific journalism. Scientific journalism is communication between scientists and the general public, often indirectly through a journalist, via newspapers and popular magazines. According to Penrose and Katz, scientists have three main reasons to communicate with the general public: economical, moral, and political (139). As explained earlier, much science is funded by the government, which is financially supported through public tax dollars toward “governmental agencies that conduct scientific research and the funding of government grant programs that support research by scientists at other institutions” (140). The moral compulsion to communicate with the public is scientist’s ethical responsibility to help the public understand scientific discoveries and technologies that could have a large impact or long-term implications for society. Scientists may also communicate with the public because in addition to funding, the public can have an influence on political policies, which may help or hinder a scientist’s research.

Scientific articles in newspapers had a very early beginning. In fact, according to Kreighbaum, there was a scientific article in the very first American newspaper, *Publick Occurrences*, which was published in Boston in 1690. This particular article was about smallpox in Boston, but as Kreighbaum points out, it had several qualities in common with modern day science reporting (20):

- 1) A public health/medicine topic that would appeal to mass media readers
- 2) A local story
- 3) A story that emphasized progress

Even today, the public consults newspapers to learn how to protect their health and read up on the latest developments in medicine (77). Other story topics that are popular include those on “energy, environmental, and economic affairs,” and it is common for these articles to either emphasize progression in the field, like new wind turbines in a local neighborhood, or expose scandals, like oil spills. In addition, such stories also often cover Kreighbaum’s second criterion: where the wind turbines are being implemented or the oil spill occurred is often a central part to the story, and is in some way relatable to the readership. In order for the journalists to get the “scoop” on these stories, however, they must rely on the scientists, just as the scientists rely on them in order to reach the public (Nelkin, 12). In the next section, I discuss why this relationship is, as Nelkin states, “strained” (8).

An Uneasy Relationship: Scientists & Journalists

Scientists often find it difficult to communicate with the public through a journalist because the two genres have very different styles and purposes. Due to their high degree of specialized knowledge, scientists tend to use very technical terminology that is difficult for the layman to understand (de Semir, 2000; Mikulak, 2011; Penz & Katz, 1990). The journalist must then translate this jargon and the abstract concepts that accompany it (Kreighbaum, 83). To do this, journalists often use metaphors to not only explain technical material, but also popularize it (Nelkin, 10). However, she describes these metaphors as “strategic tools” and quotes Loakoff and Johnson when she says that metaphors can affect the ways the audience perceives, thinks, and acts, because metaphors “structure our understanding of events, convey emotions and attitudes, and allow us to construct elaborate concepts about public issues and events” (11). Therefore, not only are journalists translating the material, they are interpreting it in a certain way. Nelkin explains this, saying, “some words imply disorder and chaos; others certainty and

precision. Selective use of adjectives can trivialize an event or render it important; marginalize some groups, empower others; define an issue as a problem or reduce it to a routine” (11). She’s not alone in suggesting that science journalists exercise an enormous amount of power (Dunwoody, 1999; Peláez, 2007). Nor is it always in a way with which scientists agree.

The general public consumes information in a very different way than scientists do. For example, newspaper articles are written not only to inform, but also to entertain (Kreighbaum, 36; Goldsmith, 22). They are designed to catch a reader’s interest quickly, and thus use flashy headlines and put the most important information first. This approach is radically different from a typical academic scientific article, which starts with a background of relevant literature and provides a very detailed methodology before any results are presented.

Not only are newspaper articles written ‘backwards,’ they also contain much less background detail and ‘accountability’ than academic articles. The very things scientists worry about being omitted from popular articles: credit to other scientists, more methodology, more skepticism- all very important for accountability- have little importance to the public (Kreighbaum, 39; Goldsmith, 24). Popular audiences are not interested in the intricacies of procedures, nor will they personally be checking the facts. If the material is quoted from what is seen as a knowledgeable source, then that is often enough accountability for this particular genre. Scientists struggle with this discrepancy on what is ‘necessary’ for proper accountability, because for them, a misprint or gross misinterpretation could mean serious damage to their reputation, or even loss of a career. For a journalist, the effects of a misprint are less severe immediately: merely less newspapers sold in a day or gradual reader distrust over time (Newton, 1962). Yet, because their work holds a lot of weight for how science is interpreted and subsequently helped or hindered by public policy, journalists do have ethical responsibility.

According to the 1960 NASW code of ethics, journalists must be accurate, truthful, and impartial in their work. Regardless of what professional codes of conduct exist, it is clear that each party involved must remain on good terms with the other for the flow of information to continue, and for each to therefore accomplish the unique goals of their very different genres.

With all this said about academic and popular genres, it is important to reiterate that there is a lack of knowledge on the trade journal genre. This lack of knowledge presents a problem for academics, who should be more familiar with this genre in order to better prepare their students, who may encounter this genre in their future careers. In addition, it is a little-acknowledged, yet powerful source of technical information, which may provide yet another avenue for research, both for students and academics.

3 : Generic Criticism: Theories and Methods

In the previous chapter, some highlights from a deductive generic criticism of scientific communication in academic journals and popular newspapers were presented in order to grasp the unique structures of each genre and how the purpose, stakeholders, and social constraints of these pieces affect and are affected by their structures. In the results section, both are compared and contrasted to scientific communication in trade journals in order to fill some gaps in the understanding of the under-studied social aspects of the genre of trade journals. However, to fully classify this genre, analysis of these social aspects must be paired with a structural analysis. Understanding how the structure of communication is influenced by its purpose, stakeholders, and social constraints can help one become a better consumer and producer of such discourse, and thus, a more successful member of that specific discourse community. This was accomplished by conducting an inductive generic criticism of a corpus of nine chemical engineering trade journal articles. The procedure used to design this study is provided below, along with the background information necessary to understand each step.

In this chapter, I examine some of the early and later theories of genre in the rhetorical field of study in order to devise a method of inductive generic criticism suitable to the study of trade journals. In addition to analyzing the stylistic features of the articles, I wanted a method that would also account for the relationship between these features and the discourse community that influenced them. Genre, at its most basic definition, means kind, sort, or style, but it has been given varying definitions by different fields of study over the years. For the purpose of this project, how literary and compositional studies have influenced the rhetorical definition of genre was the most relevant. Therefore, I first separately review the evolutions from static to dynamic theories of genre in literary and rhetorical circles in order to develop a dynamic definition of

genre that best suits my study. I then review some inductive generic criticisms conducted by others to provide a framework for my own method. Finally, I draw from this research to describe the methods of my own inductive generic criticism.

Theories of Genre

Literary Theories of Genre

According to Swales, genre has been used most commonly as a term for “classes of texts” in literary circles before the late 1900’s (36). This static version of genre allowed literary critics to use genre as a tool to classify specific texts as either belonging to or transcending relevant genres, actions that reflect Aristotle’s early use of genre as a tool for classification. This activity was particularly useful to literary critics, as their scholarly activity is “typically designed to show how the chosen author breaks the mould of convention and so establishes significance and originality” (36). Thus, literary critics were more interested by the differences between a particular piece and its genre, rather than its similarities.

Overlapping Genres

In the process of classifying a particular work as belonging to or transcending a particular genre, literary scholars grew to view genres as ubiquitous and overlapping. The view of genre as ubiquitous is perhaps best captured by Fishelov when he argues that “a writer does not create in a textual vacuum,” acknowledging that every piece of literature necessarily belongs to a genre (83). As this theory developed, literary scholars also began to acknowledge that texts could belong to multiple genres simultaneously to varying degrees, thus showing that genres themselves overlapped. For example, Mary Shelley’s *Frankenstein* has been considered to belong to both science fiction and horror, as well as other literary genres. This view of overlapping genres led to questions about how genres formed. Eventually, to answer these

questions, genre evolved from a tool only for understanding the textual elements of a work to one also capable of explaining and dependent upon the cultural, historical, socioeconomic, or political elements of a particular text (Swales, 37).

New Rhetoric

Amy Devitt argues that this shift in the definition of genre, often distinguished from formalism as ‘New Rhetoric,’ occurred around the 1980’s, and was heavily influenced by the works of Halliday, Bakhtin, Giddens, and others (697). This broader definition of genre acknowledged that although still primarily concerned with texts, cultural elements beyond the texts could be used to explain genre evolution, and thus the changing landscape of literary works, which allowed genre to become dynamic rather than static. A dynamic view of genre allowed Thomas O. Beebee to connect a literary view of genre to ideology, an element “central to much of literary theory” (Devitt, 699). He did this by defining genre as the “use-value” of texts (Bawarshi, 349). As Bawarshi put it, Beebee’s “use-value is socially determined and so makes genres in part bearers and reproducers of culture—in short, ideological” (397).

Consequently, connecting genre to ideology reaffirmed the connection of genre to culture, and thus social action, an area taken up more commonly by scholars in the compositional and rhetorical fields, and headed by Carolyn Miller in her work, “Genre as Social Action,” as described more in the next section. It is important to note that literary scholars, being interested primarily in the study and classification of literary texts with cultural value, typically look at genre as a tool to analyze texts. Therefore, when considering the groups involved with these texts, literary scholars are more concerned with the relationship of the author or critic to the text. Because the fields of linguistics and rhetoric are more concerned with the social implications of genre as a classificatory tool, these scholars concern themselves more readily with every group

that interacts with a text; including the author or critic as well as the audience. Since my project sought to capture the social implications of the trade journal genre, not just classify the structure, a rhetorical theory of genre better fits my study.

Rhetorical Theories of Genre

Like those of early literary scholars, early rhetorical studies in genre used the formalistic definition of genre described above. But they too adapted to the social ‘New Rhetoric’ definition in the 1980’s. In fact, Amy Devitt argues that Carolyn Miller’s work, drawing specifically from Halliday and Bitzer, has served to state a core agreement among new rhetorical genre theorists (697). According to Miller, “a rhetorically sound definition of genre must be centered not on the substance or form of discourse but on the action it is used to accomplish” (151). This definition emphasized genre as “typified social action rather than as conventional formulas” (Devitt, 697). For example, a business letter may have a conventional format, but be written for a variety of purposes, thus distinguishing two documents with similar structures from each other based on purpose.

Discourse Communities

With genre as an active entity rather than a passive tool, the way was opened for rhetoricians to question what sorts of groups were behind and being affected by the social actions of genres. Moving beyond the standard rhetorical triangle of author/text/audience, rhetoricians adopted the term “discourse communities,” to describe the group of writers and readers interacting with texts in a particular genre or set of related genres. This less rigid term more fully embraced the idea of an evolving two way relationship between the texts and groups of a genre. In addition, the term ‘community’ more accurately describes the groups affected by a genre. After all, many genres have complex audiences; there may be one or two primary audiences, but

other secondary audiences also often exist. For example, *Chemical Engineering Progress*, written primarily for engineers in the chemical industry, is also read by some chemical engineering students and their professors. These students and professors receive the magazine as part of their membership in the American Institute of Chemical Engineers (AIChE), which publishes the magazine.

From Speech to Discourse

The term discourse community was originally modified from the sociolinguistic term ‘speech community’. Swales quotes Hymes, defining a speech community as “a community sharing knowledge of rules for the conduct and interpretation of speech. Such sharing comprises knowledge of at least one form of speech, and knowledge also of its patterns of use” (51). Originally, this definition was simply modified to include texts rather than speech to achieve the term ‘discourse community’.

However, Swales was discontent with this definition for several reasons, including the different sizes and reach of speech vs. text-based audiences and the way speech vs. text communities differ. Most importantly, perhaps, Swales emphasizes that the term is inadequate because each community has very different communicative needs. According to Swales, the “primary determinants of linguistic behavior” in sociolinguistic speech communities are social in nature, whereas in socio-rhetorical discourse communities, these determinants are functional (24). Here Swales makes the distinction that although discourse communities are also concerned with socialization, they differ from speech communities in that the goal, or purpose the discourse community is trying to achieve, is more important than the characteristics of the socialization itself. As mentioned in the previous chapter, the methodology section of academic scientific articles is a good example of this relationship. Methodology sections are an important part of the

structure of these articles because replication is one of the principle ways to provide accountability in the field. Conversely, in popular newspaper scientific articles, this accountability is provided through expert accounts, as seen by the long quotations usually included in these pieces.

Defining Discourse Communities

Once Swales had established that a separate definition for discourse community was necessary, he devised 6 characteristics he believed a discourse community should have. Simply put, these were:

- 1) a broadly agreed upon set of public goals;
- 2) mechanisms for intercommunication among its members;
- 3) participatory mechanisms used for information and feedback;
- 4) the use and possession of one or more genres in order to further its aims;
- 5) some specific lexis; and
- 6) a “threshold level of members with suitable degree of relevant content and discorsal expertise” (24-27).

It is important to note that Swales’ definition of genre was not the formalistic literary one previously described, but of his own creation from modified new rhetoric theory. Swales defined genre as

a class of communicative events, the members of which share some set of communicative purposes. These purposes...constitute the rationale for the

genre...(which) shapes the schematic structure of the discourse and influences and constrains choice of content and style....In addition to purpose, exemplars of a genre exhibit various patterns of similarity in terms of structure, style, content, and intended audience. (58)

Here it is interesting to note that while Swales acknowledges that the rationale for a genre “gives rise to constraining conventions” that “are constantly evolving and indeed can be directly challenged,” Swales does not emphasize that the genres themselves evolve. Perhaps this remains a reason why his definition of genre is more widely used by those performing lexical based ‘move analyses’ that do not directly consider the social aspect of a genre.

Move Analyses

Move analyses examine and group the sections of a text according to the rhetorical goal, or move, being achieved, such as presentation of the goal or problem. The method also typically includes the selection of a ‘corpus’ or group of texts presumed to belong to the same genre, to be analyzed. This method, first used by Swales in a 1981 publication where he applied it to article introductions, has since been used and modified by many other scholars, including Lopez, Bley-Vroman and Selinker, Crookes, Jacoby, Cooper, and Swales himself (140). When considering why Swales did not comment on whether or not genres themselves evolve, it is important to keep in mind that Swales was a scholar and teacher of English, and that his work with genres was intended to further the “teaching of academic and research English” by presenting genre analysis “as a means of studying spoken and written discourse for applied ends” (1). These ideas fit nicely with the predominantly-lexical based move analysis. Although Swales acknowledges that discourse communities exist, he is more interested in how they possess and use genres, and thus

how genres can be used to classify texts, than any reciprocal relationship genres may have with their discourse communities.

Redefining Genre

Perhaps the earliest concrete examination of this reciprocal relationship between genres and their discourse communities was that presented by Carol Berkenkotter and Thomas Huckin in their 1994 book, *Genre Knowledge in Disciplinary Communication: Cognition/Culture/Power*. Berkenkotter and Huckin built upon the earlier ideas of Miller, Swales, Bakhtin, and others by focusing not on the use of genre to classify texts, but instead on its use when examining how “genre is embedded in the communicative activities of the members of a discipline” (2). In order to do this, they redefined genre according to the following 5 principles:

- 1) dynamism;
- 2) situatedness;
- 3) form and content;
- 4) duality of structure; and
- 5) community ownership.

At first glance, these principles are not that different from those of Swales: he too believed genres belonged to communities, that they provided content and structures that the discourse community could use as templates for new texts, and that they were responses to recurrent situations. However, Berkenkotter and Huckin make 3 very notable changes: 1) dynamism: the genres, not the conventions of them as Swales argued, “change over time in response to their

user's sociocognitive needs"; 2) duality of structure: genre rules not only constitute social structures, but also simultaneously reproduce them; and 3) community ownership: genre conventions do not only constitute "valuable ethnographic communication" for a discourse community, as Swales argued, but more broadly "signal a discourse community's norms, epistemology, ideology, and social ontology" (Swales 58; Berkenkotter and Huckin 4).

A Reciprocal Relationship

These distinctions made the discourse community a concept worthy of its own study, rather than merely as an underpinning to textual study. Consequently, they argue that informed knowledge of both written genres and the sociocognitive patterns that a particular discourse community employs when utilizing them are necessary for "full participation in disciplinary and professional cultures" (24). It is precisely this "informed knowledge" of both the texts and sociocognitive patterns of the trade journal genre that I am hoping to gather in order to demonstrate how such knowledge can lead to fuller participation in a specialized discourse community. Without the evolution of genre and discourse communities as dynamic terms that influence each other, a study of a corpus of texts from trade journals would stand on its own. Instead, in this study, that analysis is bolstered by acknowledging how the purposes, stakeholders, and constraints of trade journals work together to influence and be influenced by the structures of the texts, leading to a deeper understanding of the genre as a whole.

Developing the Method

This framework includes both deductive, or top-down, methods as well as inductive, or bottom-up methods (Foss, 2004). The analysis began with an inductive approach to determine the characteristics that would be studied in the deductive portion of the study. This inductive approach included the determination of the textual and social characteristics of the texts and

discourse communities of trade journals as determined by examining those of academic scientific journals and popular scientific journalism in order to obtain a “form” (See Chapter 2). Once the “form” was determined, it could then be applied deductively to a corpus of trade journals. While not many studies have been conducted on trade journals, other types of magazine corpuses have been studied (Carpenter & Upchurch, 2008; Siler, 2009; Glucha & Stenberga, 2006).

Choosing a Corpus

To select a corpus for my study, I first contacted the editor of CEP that I was working with, Cynthia Mascone, to get a better idea how many chemical engineering trade journals existed. She asserted that there were 3 publications that truly fit the genre, meaning they did not consist of academic articles, like *Chemical Engineering Journal*, or mostly news stories, like *Chemical and Engineering News*. These 3 trade journals were: 1) Chemical Engineering Progress (CEP), 2) Chemical Processing (CP), and 3) Chemical Engineering (CE). I decided I wanted to have 3 articles from each, so I could get an idea how each publication presented their articles differently. I was then faced with a choice: I could either choose articles based on similar topics, or articles in the same date range. Each would have different advantages and disadvantages.

Table 1: Corpus Selection Pros & Cons

Topic Based		Date Based	
Pro	Con	Pro	Con
Ability to see different angles on same topic	Could be from different years/editors/staff	Ability to see what different magazines found important during the time frame	Inability to see trends between different months
	Discrepancies in lengths and depths of articles	Wide range of topic coverage/article type	
	Hard to quantify	Easier to quantify	

I eventually decided that date based analysis would provide more objective results, as I would examine how the journals handled many different types of topics, rather than comparing how they represented a single topic. I chose to look at journals from three consecutive years, so that the staffing would be fairly consistent. For this purpose, I chose to examine the most recent 3 years, 2012-2010, so that my results would be most relevant to the industry today, and thus most helpful when using the analysis to write my article. To select the individual articles I would study, I looked at the table of contents for each journal over 3 years. I counted the number of main articles per issue and tried to choose the month with the most similarity between article type/# of articles. This automatically allowed me to ignore any months with articles that were part of a series. Through this analysis, I found June to be the most standard month. From there, I handpicked generally the main article or cover story from each journal for the June 2010 through June 2012 issue, while consciously making sure to gather a variety of article types.

When analyzing my corpus, I did not know exactly what to look for, so I designed sheets that would allow me to track as many aspects of content, stylistics, and image use as possible. I obtained ideas on what aspects might be important by skimming articles and consulting 2 handbooks: one for business writing, the other for technical writing (Alfred et al, 2006, Alfred et al, 2009). These sources were logical choices because, as a genre of industrial communication, it seemed likely that trade journals might incorporate aspects of these two professional genres, particularly for image presentation. The final coding sheets used for this study can be found in Appendix A. In total, there were 4 different types of coding sheets:

- 1) Stylistics Coding Sheet : Title, subtitle, and word counts by subsection, paragraph, and sentence.

- 2) Overall Article Coding Sheet: Title, subtitle, article type, author information, sources used, basic layout
- 3) Detailed Article Coding Sheet: Thesis statement, jargon, metaphors, quotations, examples, references, grammatical complexity, bullets/lists, conclusion
- 4) Image Coding Sheet: Image type, colors used, size, features such as axes, caption, how referenced in text, purpose, ethics

After the coding sheets were analyzed, I was able to more clearly distinguish the academic, popular, and industry-specific features of each article. A summary of these findings is presented in Chapter 4.

4 : Characterizing the Form of the Chemical Engineering Trade Journal

When I first set out to characterize the trade journal, I made the hypothesis that chemical engineering trade journals would be a synthesis of academic and professional concepts relevant to the chemical industry but written in a style similar to popular scientific communication. In the previous chapter I argued that structural analysis was needed for a full genre classification. I provided the research backdrop for my inductive trade journal article study and the procedure I followed to design and conduct it. In this chapter I revise my hypothesis and use some key results from my inductive study to support my new conclusions.

I originally hypothesized that all trade journal articles would be written in a more popular style; however, I found that was only true for some of the articles. Overall, I found that there were two broad categories of trade journal articles: one more academic and one more popular. The more academic articles were those that covered very specific technological training, like the equipment selection and process troubleshooting articles. These pieces were generally written by industrial experts in the field with many years of experience. They included very technical terms, many more acronyms, and were generally longer pieces. They also incorporated more elements from academic scientific journals and technical textbooks than they did popular elements. The more popular articles were overview articles that introduced emerging technologies such as nanomaterials or industrial concerns like dust explosions. These pieces were generally written by journal editors and included many quotes from experts. The language tended to be less technical, incorporate less acronyms, and include more metaphors.

Because the piece that I was writing for CEP fell into the overview article category, the structural features of technical training articles are mostly ignored in this section, and only referenced as juxtaposition to the structural features of overview articles. In addition, the

discussion of structural features is grouped into three main categories: 1) Credibility features, which discusses the implications of separation from audience, 2) Generic features, which include academic, popular, and textbook generic features; and 3) Industrial features, which include author biographies, broad concerns of the industry, and signs of professional networking.

Credibility Features: The Relationship Between Audiences & Authors

The authors of trade journals make persuasive claims about how operators and engineers in the field should act and provide insight into abstract concepts of the industry. Claims are more believable if supported by evidence, and the claims made in trade journal articles are no exception. In this section, I explore why providing evidence is so important in this genre, and to what degree.

Trade journal authors fall into two categories: either they are technical professionals themselves, as in highly technical articles, or they are experienced editors quoting many technical professionals, as in overview articles. In both cases, I call these technical professionals content specialists, to clarify that the authors of overview articles are not usually themselves technical professionals in the article's subject matter.

Content specialists are not generally average workers, but people with higher positions within the company, or experienced editors of the publication. This lends trade journal articles credibility and a degree of incontrovertibility, as it slightly separates the content specialist from the audience, much the way scientists are separated from the general public, but not as strongly. In newspaper articles, science is often taken as fact and there is little room for doubt. In scientific articles, scientists are often seen on more equal playing fields, and thus science is less certain and more proof must be shown. Trade journal content specialists and their audiences have varying

levels of expertise, and so some members of the audience may have a knowledge base as extensive as the content specialist, while others may have less experience.

It is important to note that the ways content specialists are directly or indirectly used to add credibility to a trade journal article mirrors the style used in academic and popular genres of scientific communication. The authors of highly technical articles can be compared to authors of academic scientific articles, who write about work they personally complete related to subject matter they have studied in great detail. In this academic scientific genre, academic credentials, such as institution where degree was earned and type of degree, are provided as evidence of expertise. Likewise, authors of highly technical articles typically write about material that is highly pertinent to their careers in which they have years of experience.

In this professional scientific genre, years in the industry, positions held, and responsibilities while in those positions provide expertise. Indeed, these are the sorts of information cited in professional resumes. In a similar fashion, popular scientific articles are written by journalists that typically quote the scientists involved in the discovery or experiment covered in the article. These editors generally have a lot of experience disseminating scientific knowledge from experts in this way. Again in this case, in the popular scientific genre, a journalist's expertise can be measured by years with prestigious publications. From my study, I found that overview trade journal articles were written by journal editors that also have a lot of experience disseminating the technical knowledge of industrial experts.

The audiences of trade journals will generally be familiar with some basic concepts related to an article's subject matter, but will not possess the same level of background knowledge as the content specialist. Therefore, authors must provide evidence that they or the content specialists they quote are credible enough to make such claims, and they must provide sufficient detail to

support the advanced claims they are making. The two types of evidence of credibility that I explore in this paper are the use of citations, in the academic features section, and author credibility, in the industrial features section.

Generic Features

As mentioned previously, trade journal genres are a hybrid genre of scientific communication that incorporates elements of both the academic scientific and popular scientific genres. In addition, I also found elements of a third genre, that of the scientific textbook. Together, the mix of these three genres allows these pieces to be instructional, informative, and accessible to practicing chemical engineers.

Academic Features

If the academic genre serves the purpose of widening the field of scientific knowledge and providing a foundation of scientific understanding, then the trade journal serves the purpose of applying this knowledge to address broad concerns of the chemical industry. In fact, the more specialized the article, the more academic features it generally incorporates. These trends are especially prominent in “A Novel Equation for Isothermal Pipe Flow,” written by Jung Seob Kim and Navneet Singh for the June 2012 issue of *Chemical Engineering*, and represented here in Figures 3-6. In this article, the authors present a “newly derived equation” to more accurately describe the physical properties of mass flux and gas flow in a pipe (66). Chemical engineers need to be able to predict and characterize these types of flows in order to size pipes, select appropriate equipment, and control chemical processes. This article first presents the relevance of the work, introducing the problem with the current isothermal model. The authors then discuss previous work that has led to their work, in this case the “homogenous equilibrium model” by Kim and Dunsheath, in the same way that academics build their work off of previous work, and

acknowledge those who completed it (66). The article continues on to present necessary background to understand the new equation and its relevance, compares it to the conventional model and notes when it is appropriate to use which, and concludes with further evidence that the assumptions of the conventional model are not accurate, thus asserting the importance of the new equation. In order to help the reader through this highly technical work, the authors incorporate a few visual features highly used in academic work: nomenclature tables, graphs, and derivations of equations.

Immediately the reader is presented with a nomenclature table, a feature common in many academic articles, and seen in Figure 3.

Engineering Practice

A Novel Equation for Isothermal Pipe Flow

A newly derived equation for isothermal gas flow in pipes yields improved mass flux predictions

Jung Seob Kim, SK E&C USA, Inc.
and Navneet Singh, Bayer CropScience LP

Compressible flow in pipes is common in the chemical process industries (CPI) and is typically associated with density changes in gases that are subjected to pressure variations. Gas flow conditions can be de-

a, l, b	stations	P	absolute pressure, Pa
D	pipe inside diameter, m	R	universal gas constant, 8314.47 Pa·m ³ /kg·mole·K
f	Fanning friction factor	T	absolute fluid temperature, K
G	mass flux, kg/s·m ²	u	velocity, m/s
G_c	critical mass flux, kg/s·m ²	v	specific volume, m ³ /kg
L	pipe length, m	Δ	arithmetic difference
M	gas molecular weight	ρ	fluid density, kg/m ³
Ma	Mach number		
N	overall loss coefficient, $4fL/D + \sum K$ (total flow resistances of fittings)		

Figure 3: Academic Features in a Trade Journal: Nomenclature Table

Nomenclature tables are a very specialized, familiar way to present the reader with a lot of technical information that the reader will need to understand the article, such as variables for equations and their units. Academics and engineers use variables to represent physical characteristics of a system, such as pipe length, here L , and velocity of flow, here v . These variables, and the others in the table, describe all of the physical characteristics needed to understand and predict isothermal pipe flow. In this particular article, the feature is particularly important, because the article introduces a new equation and includes derivations. Therefore, knowing the variables will allow the reader to be able to more clearly understand the differences between the two equations, and see these differences in a more concrete way.

Two other specialized ways of presenting complex information that are typically found in academic articles, graphs and equations, are found on the second page of this article, and shown in Figure 4.

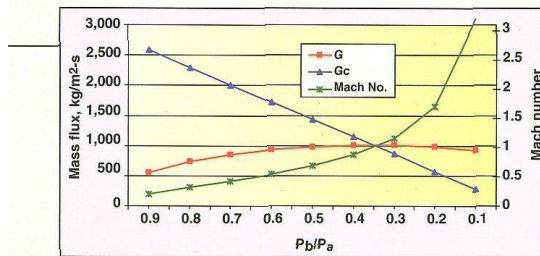

FIGURE 2. Mass flux predictions with the conventional isothermal flow equation tend to be higher because the equation does not correctly account for gas density changes

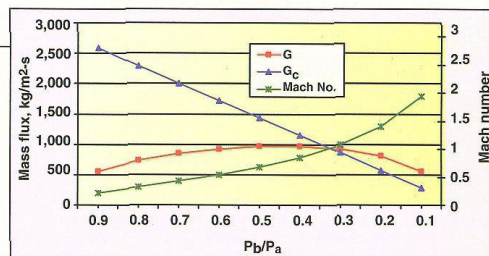

FIGURE 3. With the same piping system and inlet conditions as in Figure 2, the novel isothermal equation yields a smaller mass flux

pressure does not increase the mass flux. The choked mass flux is defined as Equation (2). Mach number is the ratio of the gas velocity to the velocity of sound in the gas under the given conditions and can be defined as Equation (3).

$$G^2 = \rho_{avg} (P_a - P_b) \frac{1}{\ln \frac{P_a}{P_b} + \frac{N}{2}} = \frac{M}{2RT} (P_a^2 - P_b^2) \frac{1}{\ln \frac{P_a}{P_b} + \frac{N}{2}} \quad (1)$$

$$G_c = P_b \left[\frac{M}{RT} \right]^{0.5} \quad (2)$$

$$Ma_b = \frac{G}{G_c} \quad (3)$$

For the plot in Figure 2, an ideal gas of molecular weight 20

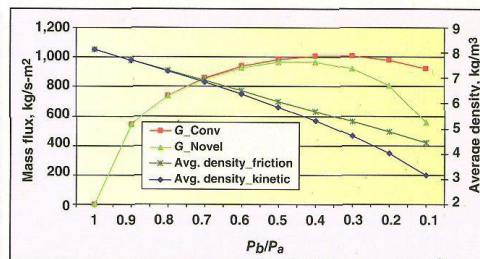

FIGURE 4. Mass flux and average density plots can help determine whether the novel or conventional isothermal flow equation should be used

Figure 4: Academic Features in a Trade Journal: Graphs & Equations

Here the reader finds detailed, numbered equations broken down into simpler variables, as seen on the left side of the image. These variables describe complex physical properties of pipe flow: mass flux, choked mass flux, and Mach number, represented as G , G_c , and Ma , that are then presented in the three figures at the top of the image. These graphic representations present the different outcomes of the old equation and the new equation for a range of mass flux values and pressures in terms of the three complex physical properties described in each of the three equations.

The graphs more easily show how the old and new equations affect these three properties in a range of conditions, rather than presenting a single or a few conditions in numerical form. Therefore, through these images, the authors can more easily give the reader more information, and make their claims stronger.

Note how the captions are not merely descriptive, however, as one would expect to find in academic articles. Instead they are persuasive, and also slightly instructional: “Mass flux predictions with the conventional isothermal flow equation *tend to be higher* because the equation *does not correctly account* for gas density changes, “ and “Mass flux and average density plots *can help determine* whether the novel or conventional isothermal flow equation *should be used* (67).” (Emphasis own.) These captions bring the author’s arguments about the new equation into a more visible location that the reader is more likely to see first, rather than simply buried in the text.

Finally, on the last page of this article the reader finds credible, academic work and sources to support the arguments of the author. As mentioned previously, in the academic genre scientists are on a more even playing field than that of the public genre, and so there is more room for doubt, and more explanation and evidence must be shown. This final page presents

such evidence in the form of a detailed derivation, shown in Figure 5, which readers can easily follow to check for accuracy.

DERIVATION OF THE NOVEL, ISOTHERMAL HORIZONTAL-PIPE-FLOW EQUATION

On the basis of the Bernoulli equation, if there is no friction, a general mechanical-energy equation for horizontal pipe flow can be written as:

$$\frac{dP}{\rho} + d\left(\frac{u^2}{2}\right) = 0 \quad (\text{A-1})$$

Since $d\left(\frac{u^2}{2}\right) = u \, du$, Equation (A-1) can be written as:

$$\frac{dP}{\rho} + u \, du = 0 \quad (\text{A-2})$$

Since $\rho = \frac{1}{v}$ and $u \, du = G^2 v \, dv$, Equation (A-2) can be written as:

$$v \, dP + G^2 v \, dv = 0 \quad (\text{A-3})$$

Integrating Equation (A-3) between stations a and b gives:

$$(P_a - P_b) = -G^2 \frac{(v_a^2 - v_b^2)}{2v_{avg}} \quad (\text{A-4})$$

For an isothermal flow of ideal gases $\left(v = \frac{RT}{MP}\right)$, Equation (A-4) becomes:

$$(P_a - P_b) = G^2 \frac{1}{2v_{avg} P_b^2} \left(\frac{RT}{M}\right)^2 \left[1 - \left(\frac{P_b}{P_a}\right)^2\right] \quad (\text{A-5})$$

Equation (A-5) is defined as a kinetic loss term. However, the kinetic loss term includes an expansion loss term. For an actual pipe flow, a friction loss term is required to be included in Equation (A-5). Since the friction loss term is $\frac{G^2}{2\rho_{avg-friction}} N$, Equation (A-5) can be written as:

$$(P_a - P_b) = G^2 \left[\frac{1}{2v_{avg} P_b^2} \left(\frac{RT}{M}\right)^2 \left[1 - \left(\frac{P_b}{P_a}\right)^2\right] + \frac{1}{2\rho_{avg-friction}} N \right] \quad (\text{A-6})$$

Since $v_{avg} = \frac{1}{\rho_{avg-kinetic}} = \frac{v \, dP}{P_a - P_b} = \frac{RT \ln \frac{P_a}{P_b}}{M(P_a - P_b)}$ and

$$\rho_{avg-friction} = \frac{\rho \, dP}{(P_a - P_b)} = \frac{M(P_a + P_b)}{2RT}$$

Equation (A-6) can be written as:

$$(P_a - P_b) = G^2 \frac{RT}{M} \left[\frac{(P_a - P_b)}{2P_b^2 \ln \frac{P_a}{P_b}} \left[1 - \left(\frac{P_b}{P_a}\right)^2\right] + \frac{1}{(P_a + P_b)} N \right] \quad (\text{A-7})$$

Rearranging Equation (A-7) for G^2 gives:

$$G^2 = \frac{M}{RT} \frac{(P_a - P_b)}{\frac{(P_a - P_b)}{2P_b^2 \ln \left(\frac{P_a}{P_b}\right)} \left[1 - \left(\frac{P_b}{P_a}\right)^2\right] + \frac{N}{P_a + P_b}} \quad (\text{A-8})$$

Figure 5: Academic Features in Trade Journals: Derivation

In this derivation, the authors show how they developed their new equation from the same basic principles as the conventional equation. Their work is based in academic theory, as shown by the reference to the Bernoulli equation, a highly used physics equation to describe flow. Note how the assumptions made are also listed, in this case, no friction. Presenting these assumptions is common in academic theory so that others can follow and continue the work of their predecessors. To further help the readers follow their work, this derivation clearly describes the steps between each manipulation of the equation, for example, “integrating Equation [A-3]

...gives” and “for an isothermal flow of ideal gases” where certain conditions are met, “equation [A-4] becomes” (70).

The authors additionally provide many credible citations to back up their claims, shown in Figure 6, as is typical of academic articles.

References

1. Kim, J.S. and Dunsheath, H.J., “A Homogeneous Equilibrium Model Improved for Pipe Flows,” Proceedings of World Congress on Engineering and Computer Science 2010 Vol. II WCECS 2010, October 20–22, San Francisco, pp. 733–738, 2010.
2. Shapiro, A.H., “The Dynamics and Thermodynamics of Compressible Fluid Flow,” Vol. 1, The Ronald Press Company, New York, 1953.
3. McCabe, W.L. and Smith, J.C., “Unit Operations of Chemical Engineering,” McGraw-Hill, New York, 1976.
4. Crowl, D.A. and Louvar, J.F., “Chemical Process Safety: Fundamentals with Applications,” Prentice-Hall, Englewood Cliffs, N.J., 1990.
5. Saad, M.A., “Compressible Fluid Flow,” Prentice-Hall, Englewood Cliffs, N.J., 1985.
6. Holland, F.A. and Bragg, R., “Fluid Flow for Chemical Engineers,” Elsevier Inc., Amsterdam, 1995.
7. Green, D. and Perry, R.H., “Perry’s Chemical Engineers’ Handbook,” McGraw-Hill, 2008.
8. “Flow of Fluids through Valves, Fittings, and Pipe,” Crane Technical Paper No. 410, 1988.
9. “Pressure-relieving and Depressuring Systems,” ANSI/API Standard 521, pp. 104–110, January 2007.
10. Kern, R., How to Size Piping and Components as Gas Expands at Flow Conditions, *Chem. Eng.*, October, 1975, pp. 125–132.
11. Walters, T., Gas-Flow Calculations: Don’t Choke, *Chem. Eng.*, January 2000, cover story.

Author



Jung Seob Kim is a senior process engineer at SK E&C USA Inc. (1401 Enclave Parkway Suite 100, Houston, TX 77077; Phone: 281-258-2619; Email: jkim3@sk.com) where he is responsible for designing petrochemical and refinery plants. He has more than 25 years of experience in different roles within the petrochemical process industry including with Bayer Technology Services, Samsung BP Chemicals and Samsung Engineering. He holds a B.S.Ch.E. from the University of Seoul, is a member of AIChE, and is a registered professional engineer in the State of Texas.



Navneet R. Singh is a Senior Process Engineer at Bayer CropScience LP (8400 Hawthorne Road, Kansas City, MO 64120; Phone : 816-242-2738; Email: navneet.singh@bayer.com) where he is responsible for process design, process modeling and emergency relief system design. He holds M.S. and Ph.D. degrees from Purdue University and a B.S.Ch.E. degree from the Institute of Chemical Technology, Mumbai. He is a Senior member of AIChE and an engineer intern in the State of West Virginia.

70 CHEMICAL ENGINEERING WWW.CHE.COM JUNE 2012

Figure 6: Academic Features in Trade Journal Articles: Citations: Highly Technical Article

These citations add credibility in much the way they do in the academic genre: by showing the author has studied credible work that can support their claims. Interestingly, the highly technical articles, which typically exhibit more academic features, also tend to include more citations than overview articles. For example, in this article, the authors cite 11 sources.

In contrast, an example of recommended reading from an overview article is shown in Figure 7, where the final page “Preventing Dust Explosions: Are You Doing Enough?” written by Suzanne Shelley for the March 2008 issue of *Chemical Engineering Progress* is reproduced.

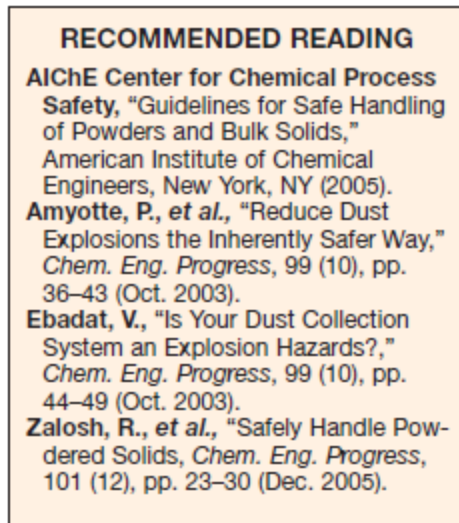

Figure 7: Academic Features in a Trade Journal: Citations: Overview Article

From a contrast of the figures, it appears that the overview article contains no citations. However, this is yet another difference between overview articles and highly technical articles. In highly technical articles, the emphasis of citations is placed on providing credibility. In overview articles, this credibility is more contained in expert quotes, so the formal citations are instead used to point readers to additional reading. Note how this journal cites several other relevant articles from the same publication, encouraging readers to read more of their publication, which could be a useful strategy for ad exposure. However, there are some text sources cited in "Explosions," but they are cited in text. For example, in the middle column of Figure 8 the author cites a 2005 report by the US Chemical Safety and Hazard Investigation Board. Regardless, the number of citations in this article is significantly less than that of the "Novel Equation" article.

But perhaps even more interesting than the use of this academic credibility method in this professional genre is the type of works cited. In the Generic Features section, I argued that trade journal articles incorporated elements of academic, popular, and textbook genres of scientific

communication. In Figure 6, there are 5 citations from textbooks (#2-6), including Unit Operations, which is cited in Figure 10. Also notice the variety of other citations here, which would not be found in academic articles. Citations #10 and 11 are for other Chemical Engineering articles, perhaps following the same purpose as in overview articles, to encourage readers to read more of the publication. Or perhaps these citations are included to show a continuation of work, as is often the case in academic scientific journals. Citations #8 and 9 are for a technical paper and an industrial standard, specifically, two genres with specific ties to the professional community. Also note citation #1, of a “proceedings of World Congress on Engineering & Computer Science,” which may have been a gathering of academics and professionals, and citation #7, for Perry’s Handbook, a professional reference that condenses much of the academic theory presented in textbooks. These types of citations are not typically found in academic or popular articles, and directly tie to the industry-specific purposes of this genre.

Popular Features

Toward the other end of the continuum is the overview article, which exhibits more popular features. A good example of this type of article is “Preventing Dust Explosions: Are You Doing Enough?” written by Suzanne Shelley for the March 2008 issue of *Chemical Engineering Progress*. On the first page of the article, shown in Figure 8, the reader is immediately presented with a large, colorful picture depicting an explosion.

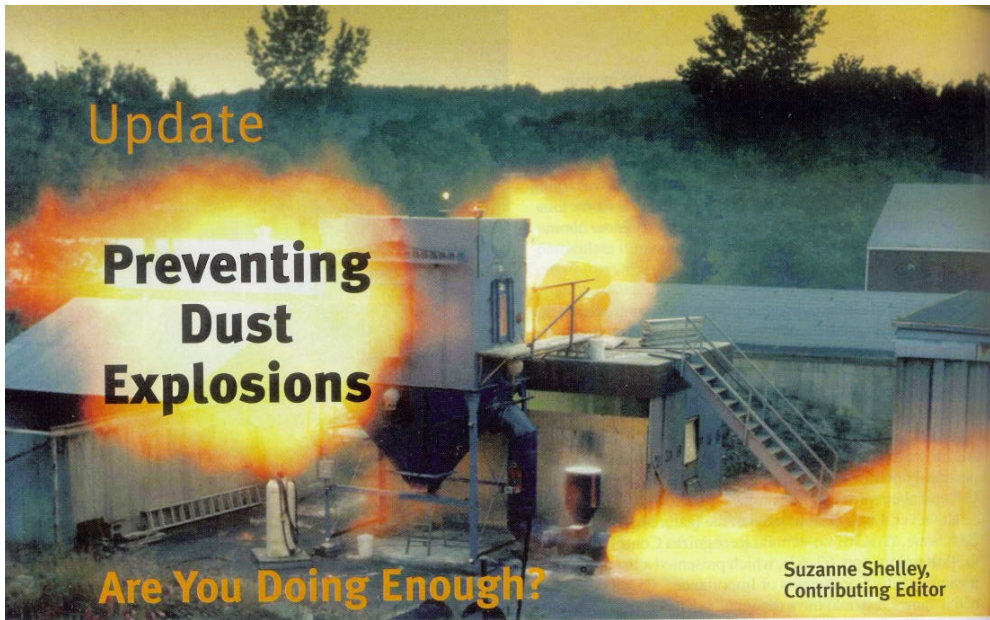

Plastic resins and nylon fibers, sawdust and grains, metals and coal dust, pharmaceutical ingredients, calcium carbide, flour, cocoa, starch and milk powder. What do these seemingly innocuous materials have in common? Ostensibly nothing, except that under the right conditions, all of these benign powders can explode — and have been to blame for deadly deflagrations in industries that span the spectrum of the chemical process industries (CPI).

Pending a comprehensive investigation, sugar dust is being blamed for the catastrophic explosion that leveled the Port Wentworth, GA, sugar refinery operated by Imperial Sugar Co. (Houston, TX) on Feb. 7. In that event, at least 11 employees were killed and another 42 workers were injured, many of them critically with severe burns. The facility was demolished (Figure 1). Following the explosion, Georgia Fire Commissioner John Oxendine told Reuters: “I’ve been state fire commissioner for 14 years and this is the worst industrial accident we’ve had.”

As has been shown time and time again, dust explosions can have devastating consequences, in terms of loss

Experts agree that greater vigilance is needed to snuff out the ever-present risk at facilities handling powdered materials.

of life, destruction of property, productivity losses and business interruptions. They also create significant economic repercussions for the community and shareholders, engender negative publicity, and increase the risk of litigation, higher insurance premiums and increased costs of reconstruction.

According to a comprehensive 2005 report by the U.S. Chemical Safety and Hazard Investigation Board (CSB; Washington, DC; www.csb.gov), between 1980 and 2005, at least 281 deadly dust explosions occurred in the U.S., killing 119 people and injuring 718 others, and extensively damaging or destroying the facilities.

“With dust explosions, everything happens so fast — in the blink of an eye — and the initial event can quickly trigger subsequent explosions. There’s literally no time to react,” says Bill Stevenson, vice president of engineering for CV Technology, Inc. (West Palm Beach, FL; www.cvtechnology.com).

“Countless dust-related deflagra-

tions take place every day, but if no fatalities or major devastation occur, most of these events never get covered in the press,” adds Randy Davis, director of industrial explosion protection for Fenwal Protection Systems (Ashland, MA.; www.fenwalprotection.com). “More than half the time, these initial explosions are happening at facilities that had never experienced a dust explosion before. Sadly, it often takes an incident before many companies will finally make a financial commitment to put the appropriate protections in place.”

It’s one thing to speak in sweeping generalizations, but it’s another to put a human face to the devastation that dust explosions incur. For instance, phenolic resin powder was to blame in

■ Photo above: Roughly half of all dust explosions originate in dust collectors that are used to capture airborne powders, and flame propagation through connected piping (as shown in this demonstration) compounds the danger. The use of engineered controls can help. Photo courtesy of Fenwal Protection Systems

Figure 8: Popular Features in a Trade Journal Article: Pictures & Metaphors

Pictures were much more common in the overview articles than in the highly technical articles, just as pictures are used much more frequently in newspapers and nearly not at all in academic articles. In addition, this article presents accounts from many explosions, much the way a newspaper article would cover catastrophic incidents like these explosions or oil spills. On this first page, the author discusses an accident at a sugar refinery in Georgia. However, rather than simply reporting on what happened, the author of this article places the explosions in a frame of prevention, using the examples to highlight what readers can do to make their own workplaces safer.

Metaphors, which are used frequently in popular and nearly always absent in academic, made little appearance in trade journal articles in my study. Metaphors are used in popular scientific because they can make abstract concepts more accessible to unspecialized audiences. However, since the audience of a trade journal is less distanced from the technical concepts being presented in these articles than a layman, metaphors are not as necessary for audience understanding. However, in the few cases metaphors did arise, it was in those articles that more closely related to the popular genre. For example, on the first page of this article, in Figure 8, the reader is immediately greeted with the concept of “snuffing out” risks inherent in handling powdered materials. If the reader pays attention, he/she can also notice that the author has chosen to personalize powders, stating “sugar dust is being blamed” rather than the much more academic phrase “sugar dust was the perceived cause” of an explosion. This type of personalization, absent in academic writing, further places this article toward the popular end of the continuum.

Textbook Features

One genre of scientific communication I encountered that I had not initially considered was that of the scientific textbook. I had anticipated that one of the purposes of the articles would be continuous education, but was not expecting to see this purpose manifest itself in such an instructional manner. The features of the scientific textbook genre can be seen in “Reduce Gas Entrainment in Liquid Lines” written by Tamagna Ukil and Thomas Mathew for the June 2011 issue of *Chemical Engineering*, and shown in Figure 9, and again in “Selecting a Heat Exchanger Shell” written by Thomas Lestina for the June 2011 issue of *Chemical Engineering Progress*.

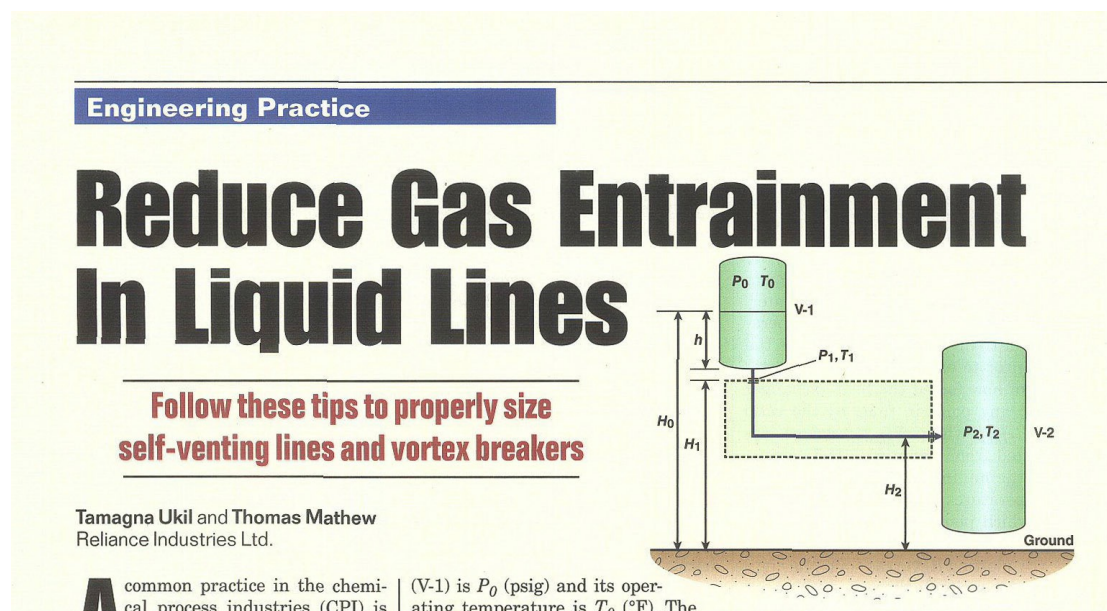

Figure 9: Textbook Features in a Trade Journal Article: Textbook Diagrams

In “Reduce Gas Entrainment,” the reader is immediately presented with a textbook-like figure describing fluid flow. I had encountered similar figures in my own chemical engineering classes, and recognized it immediately. It is likely that other practicing chemical engineers would identify with the image as well, as fluid flow problems of all kinds are common in the industry, making it a particularly effective representation of this abstract concept. Note how the variables,

described earlier as ways to describe complex physical properties, are presented in the context of the physical objects they affect. For example, H , used for the three different heights in this figure, is accompanied by a line that helps the reader see what height the variable describes, and how that height relates to the equipment shown. This is important to chemical engineers because gravity is a factor in calculations like power needed for a pump to function. In addition, the numbers 1 and 2 and the direction of the arrow between the two green ovals, used to represent vessels, let the reader quickly see the direction of the flow. Also, in the text the author provides a “theoretical basis” for the article, listing the assumptions made much in the way assumptions are listed in classroom instruction.

The page shown in Figure 10 is taken from *Unit Operations of Chemical Engineering* by McCabe and Smith, where a similar figure is being used to provide context for a different fluid flow problem, in this case, for calculating pump power.

EXAMPLE 4.6. In the equipment shown in Fig. 4.10, a pump draws a solution of specific gravity 1.84 from a storage tank through a 3-in. (75-mm) Schedule 40 steel pipe. The efficiency of the pump is 60 percent. The velocity in the suction line is 3 ft/s (0.914 m/s). The pump discharges through a 2-in. (50-mm) Schedule 40 pipe to an overhead tank. The end of the discharge pipe is 50 ft (15.2 m) above the level of the solution in the feed tank. Friction losses in the entire piping system are 10 ft · lb_f/lb (29.9 J/kg). What pressure must the pump develop? What is the power delivered to the fluid by the pump?

Solution. Use Eq. (4.65). Take station *a* at the surface of the liquid in the tank and station *b* at the discharge end of the 2-in. pipe. Take the datum plane for elevations through station *a*. Since the pressure at both stations is atmospheric, $p_a = p_b$. The velocity at station *a* is negligible because of the large diameter of the tank in comparison with that of the pipe. For turbulent flows the kinetic energy factor α can be taken

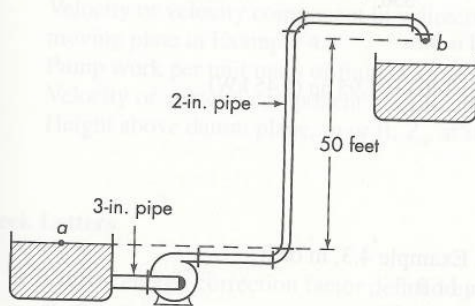

FIGURE 4.10
Flow diagram for Example 4.6.

Figure 10: Textbook Example with Figure

In this figure, the same features are used: ovals for vessels, *a* and *b* to let the reader know the direction of the flow. Here the figure is being used to provide context for the problem in Example 4.6 about pump power. Visualizing problems in this way makes them easier to solve, and chemical engineering students are constantly presented with such figures or told to draw them.

In “Selecting a Heat Exchanger Shell,” shown in Figure 11, the instructional tone is presented even more strongly.

Cold Fluid	Water
Hot Fluid	Water
Cold Temperature	In = 25°C, Out = 50°C
Hot Temperature	In = 115°C, Out = 53.55°C
Design Heat Load	4.39 MW

TEMA Type	AEU	AFU
Number of Tube Passes	2	4
Maximum Heat Load	5.03 MW	5.64 MW
Mean Temperature	15.8°C	21.2°C
Difference under Clean Conditions		
Shellside Pressure Drop	9.4 kPa	8.3 kPa
Shell Diameter and Length	0.508 m × 7.315 m	0.7 m × 4.877 m
Heat-Transfer Area	146 m ²	137 m ²

tube pitch, and bundle entry and exit design). Figure 3 compares the relative pressure drop of the common shell types, assuming the same shell diameter, shell length, and flowrate. K-shells are not included in this comparison because they are usually considered to have negligible pressure drop.

- *Maintenance.* When bundle removal is required, multipass shells have a disadvantage compared to single-pass shells, particularly when the longitudinal baffle must be removed. Longitudinal-baffle removal requires mechanical leaf seals, which can be damaged during the removal and installation process. Flow bypassing due to damaged seals severely reduces thermal performance. Because of this susceptibility, some processing facilities do not allow the use of F-shells.

- *Specific applications.* In some applications, one shell type has a clear advantage over other types. For pure-component boiling with 100% vaporization, K- and X-shells are most common. For tubeside thermosiphon reboilers, vertical E-shells are typically selected. For viscous liquids, horizontal E-shells with segmental horizontal baffles are the norm. For high-pressure applications where

When bundle removal is required, multipass shells have a disadvantage compared to single-pass shells.

special channel closures are used (TEMA D-type front heads), E-shells are usually chosen.

To determine the best shell type for an application, consider the advantages and disadvantages summarized in Table 2.

The following examples demonstrate the selection of shells for several common applications (using results generated by HTRI's Xist v. 6 software).

Example 1: Water-water heat exchanger

A water-water heat exchanger in service for more than 30 years experienced material degradation and needs to be replaced. Table 3 lists the current design process conditions. The design terminal temperature approach is 3.55°C, which any shell type can handle. Reverse heat transfer is observed for 25% of the surface area under clean conditions, which is attributed to the flow configuration and substantial fouling factors (60% of the thermal resistance). This situation is not desired, since heat duty should be maximized for this application.

Table 4 compares the existing TEMA AEU design (A = stationary front head with removable channel and cover; E = one-pass shell; U = U-tube bundle rear head) with an AFU design (F = two-pass shell with longitudinal baffle). Under clean conditions, the F-shell design exhibits no reverse heat transfer, the mean temperature difference and duty are larger, and the required heat-transfer area is less. In addition, the F-shell — a 4-pass U-tube design — can be removed without removing the longitudinal baffle. One surprising result is that the shellside pressure drop is lower for the F-shell, the result of a change in the baffle design and a shorter bundle length.

In this application, the shellside nozzle locations can be moved. Therefore, the F-shell is a better choice for this retrofit application.

Example 2: Once-through reboiler

A once-through vertical reboiler unit failed upon startup, and the operator plans to replace it with a horizontal shellside reboiler. Shellside reboiler designs are less

TEMA Type	E-Shell	G-Shell	X-Shell
Shell Diameter and Length	1.55 m × 6.096 m	1.5 m × 6.096 m	1.7 m × 6.096 m
Mean Temperature Difference	11.1°C	9.5°C	10.9°C
Required Static Head	6.8 m	4.8 m	4.0 m

Figure 11: Textbook Features in a Trade Journal: Instructional Examples

Here the reader is presented with examples of realistic heat exchanger situations, tables of options, and provided with an explanation of the best option. These types of examples are reminiscent of class problems where students are asked to consider the information given and make the best selection. The tables use acronyms, allowing for a more concise design, while the full term is presented in the text. This is also a common occurrence in textbooks, where more detailed information may be provided in the text not only to make tables appear less cluttered, but also to increase the chances that students will read the text, and thus develop a greater understanding of the material presented.

Industrial Features

I originally hypothesized that the trade journal genre would fall between academic and popular genres of scientific communication. In many ways, a majority of the articles I examined do, as they both further the field and disseminate knowledge, in very specific ways. However, I have demonstrated that this genre is clearly differentiated from both genres through its mixing of the two, its inclusion of elements of the textbook genre, and the very specific types of sources cited, including professional standards and references, technical papers, and conference proceedings. Another very specific and overarching way that these articles differentiate from other genres of scientific articles is the use of years of experience and professional credentials as credibility and the clear focus on industry-specific concerns and objectives. These concerns and

objectives not only manifest themselves in the types of articles written, but also in the features included for professional networking.

Author Credibility

The authors or content specialists of highly technical articles are generally considered very knowledgeable about the topics about which they write, sometimes having a lot of personal experience with the topic in question. In overview articles, knowledge about the topic will be gathered by several interviews with experts in the field. But what makes these experts any more knowledgeable than any other engineer? Trade journal authors must provide evidence that they, or the people they are quoting, are qualified enough to make the claims they are making. For highly technical articles, these qualifications are included in a highly condensed author biography found at the end of the article. For overview articles, an expert's qualifications are typically provided in text, and so include much less detail.

An example of an author biography can be found below in Figure 12, taken from “A Novel Equation for Isothermal Pipe Flow,” written by Jung Seob Kim and Navneet Singh for the June 2012 issue of *Chemical Engineering*.

Author



	<p>Jung Seob Kim is a senior process engineer at SK E&C USA Inc. (1401 Enclave Parkway Suite 100, Houston, TX 77077; Phone: 281-258-2619; Email: jkim3@sk.com) where he is responsible for designing petrochemical and refinery plants. He has more than 25 years of experience in different roles within the petrochemical process industry including with Bayer Technology Services, Samsung BP Chemicals and Samsung Engineering. He holds a B.S.Ch.E. from the University of Seoul, is a member of AIChE, and is a registered professional engineer in the State of Texas.</p>		<p>Navneet R. Singh is a Senior Process Engineer at Bayer CropScience LP (8400 Hawthorne Road, Kansas City, MO 64120; Phone : 816-242-2738; Email: navneet.singh@bayer.com) where he is responsible for process design, process modeling and emergency relief system design. He holds M.S. and Ph.D. degrees from Purdue University and a B.S.Ch.E. degree from the Institute of Chemical Technology, Mumbai. He is a Senior member of AIChE and an engineer intern in the State of West Virginia.</p>
---	---	---	---

Figure 12: Credibility Features: Author Biographies

Note how these biographies combine academic and professional credentials. For example, academic credentials include degree type and institution where it was earned, in this case Jung Seob Kim has a Bachelor's Degree of Science in Chemical Engineering from the University of Seoul, and Nanveet has a Master's and PhD from Purdue University on top of his own Bachelor's of Science from the Institute of Chemical Technology, Mumbai. The biographies also list current position at current company, for example, Nanveet Singh is a Senior Process Engineer at Bayer CropScience LP, and years of experience at other companies, Jung Kim has "more than 25 years of experience in different roles within the petrochemical process industry." Note how current position and job role is listed first, showing how it is clearly seen as the most credible piece of information, similar to how a professional resume is organized.

Other details include previous positions/job responsibilities held, for example, Jung Kim has worked at Bayer Technology Services, Samsung BP Chemicals, and Samsung Engineering, mention of professional community involvement (in this case, AIChE), and mention of license held, in this case, Jung Seob Kim "is a registered professional engineer in the State of Texas". These biographies also include a picture, with the author in professional clothes, for additional ethos. The inclusion of contact information will be discussed in the professional networking section, but note its prominent location as the second piece of information listed.

It is important to note that overview articles typically do not provide author biographies for the editors that write them. Instead, since the real credibility for these pieces is found in the quotations collected from experts, each person quoted is given a small introduction. Examples of this can be found in Figure 13, reproduced from "Preventing Dust Explosions: Are You Doing Enough?" which appeared in the March 2008 issue of *Chemical Engineering Progress*.

Plastic resins and nylon fibers, sawdust and grains, metals and coal dust, pharmaceutical ingredients, calcium carbide, flour, cocoa, starch and milk powder. What do these seemingly innocuous materials have in common? Ostensibly nothing, except that under the right conditions, all of these benign powders can explode — and have been to blame for deadly deflagrations in industries that span the spectrum of the chemical process industries (CPI).

Pending a comprehensive investigation, sugar dust is being blamed for the catastrophic explosion that leveled the Port Wentworth, GA, sugar refinery operated by Imperial Sugar Co. (Houston, TX) on Feb. 7. In that event, at least 11 employees were killed and another 42 workers were injured, many of them critically with severe burns. The facility was demolished (Figure 1). Following the explosion, Georgia Fire Commissioner John Oxendine told Reuters: “I’ve been state fire commissioner for 14 years and this is the worst industrial accident we’ve had.”

As has been shown time and time again, dust explosions can have devastating consequences, in terms of loss

of life, destruction of property, productivity losses and business interruptions. They also create significant economic repercussions for the community and shareholders, engender negative publicity, and increase the risk of litigation, higher insurance premiums and increased costs of reconstruction.

According to a comprehensive 2005 report by the U.S. Chemical Safety and Hazard Investigation Board (CSB; Washington, DC; www.csb.gov), between 1980 and 2005, at least 281 deadly dust explosions occurred in the U.S., killing 119 people and injuring 718 others, and extensively damaging or destroying the facilities.

“With dust explosions, everything happens so fast — in the blink of an eye — and the initial event can quickly trigger subsequent explosions. There’s literally no time to react,” says Bill Stevenson, vice president of engineering for CV Technology, Inc. (West Palm Beach, FL; www.cvtechnology.com).

“Countless dust-related deflagra-

tions take place every day, but if no fatalities or major devastation occur, most of these events never get covered in the press,” adds Randy Davis, director of industrial explosion protection for Fenwal Protection Systems (Ashland, MA.; www.fenwalprotection.com). “More than half the time, these initial explosions are happening at facilities that had never experienced a dust explosion before. Sadly, it often takes an incident before many companies will finally make a financial commitment to put the appropriate protections in place.”

It’s one thing to speak in sweeping generalizations, but it’s another to put a human face to the devastation that dust explosions incur. For instance, phenolic resin powder was to blame in

■ Photo above: Roughly half of all dust explosions originate in dust collectors that are used to capture airborne powders, and flame propagation through connected piping (as shown in this demonstration) compounds the danger. The use of engineered controls can help. Photo courtesy of Fenwal Protection Systems

Experts agree that greater vigilance is needed to snuff out the ever-present risk at facilities handling powdered materials.

Figure 13: Credibility Features: Expert Quotations Bios

For example, Bill Stevenson, who’s first quote for this article is at the bottom of the middle column, is introduced with his current position and company. Note that he is vice president of engineering, an executive position that implies he has years of experience in the field. The same is true for Randy Davis, introduced at the top of the third column, who is director of industrial explosion protection for Fenwal Protection Systems. Further, note that contact information is provided in-text. This will also be discussed in the Professional Networking section.

Broad Concerns of Industry

Trade journal articles are written to provide continuous training, keep engineers up to date with an ever-changing field, and advance the chemical industry. From my analysis, I identified 6 major categories of chemical engineering trade journal topics: 1) Process Safety, 2) Trouble-Shooting Technical Challenges, 3) Equipment Selection, 4) Emerging Processes & Technologies, 5) Education & Training, and 6) Career Trajectories & Mentoring. By keeping engineers up to date and constantly learning, trade journals help to keep the workforce educated and strong. A strong, educated workforce can help the industry develop toward further success. Therefore, it can be argued that each category of article type addresses the broad goals of the genre in some way.

Process safety is a large topic for chemical engineers, in particular because jobs in the field can include exposure to hazardous chemicals or dangerous pressures and temperatures. AIChE makes process safety a large part of its organization through student safety certification programs and the emphasis placed on safety in annual conferences. Indeed, this culture of safety also influences their publication, CEP, which had more safety-driven articles than the other trade journals examined in this study.

Economic efficiency is another large concern for chemical engineers. These jobs sometimes involve very expensive equipment, and thus choosing the right equipment for the job and keeping it in good working order is not only a safety concern, but an economic one. Maintenance, replacements, and damage from leaks or ruptures can all be costly. Businesses as a whole are always looking to reduce costs and increase profits in order to remain successful. Two very specific ways that chemical engineers can make economic decisions is through proper equipment selection and maintenance.

Not only do trade journal articles address very specific concerns and objectives to the industry, but they do so with a very specific tone. In academic articles, knowledge is somewhat passively presented. Scientists provide details from their research in order to argue that their work is important and should be furthered. In popular articles, knowledge is presented somewhat strategically to people who have some degree of influence over public policy and governmental funding. However, I argue that neither of these genres directly address their primary audiences as directly and actively as the trade journal genre does. Note how the “Explosions” article discussed previously framed powder explosions through an attitude of prevention, not one of scandal. Indeed, the piece directly addresses the reader, not “is enough being done?” but “*are you doing enough?*” One of the subheadings for this article, “What’s an operator to do?” directly addresses steps that operators can take to make their operations more safe. Likewise, the author in “Novel Equation” presents a new equation, but rather than simply stressing how it improves upon previous methods, he presents informative graphs to help the reader choose when each equation is most suitable.

This direct addressing of the reader, and specific instructions aimed at him/her, is unique to this genre. I argue that while it may borrow its instructional tone from the textbook genre, it is very important to consider the different contexts of these articles. In textbooks, fluid flow problems are presented as hypothetical situations, in a very low stakes environment. A student, as yet not expected to have much knowledge of these technical concepts, will only receive a lower grade if they fail to solve a fluid flow problem correctly. However, a chemical engineer in a company is expected to be very familiar with these concepts, and if they do not understand them fully, it can result in reduced product quality, damage to equipment, or even loss of life. Therefore, the stakes are much higher, and the problems presented in trade journals have a more

immediately realistic significance with real world consequences. This is yet another reason that this genre merits further study, as it is not only radically different from other genres, but it is just as relevant for fully educating students on the types of texts they may be exposed to in the future.

Professional Networking

A final feature unique to this genre is the inclusion of contact information for content specialists. This information was previously presented in the Author Credibility section and Popular Features sections. Providing this information allows readers to reach out to the specialists for professional networking, much the way that presenters tend to include contact information in conference slides/programs. Further opportunities to network can be provided through an acknowledgements section, which provides readers with contact information for more people knowledgeable about a specific industrial topic. Professional networking provides readers not only with the opportunity for personal development, but also, holistically, with the opportunity to contribute to the growth and development of the industry as a whole through the mutual sharing of ideas.

Conclusions

From Genre Analysis to Article Development

For the purposes of writing my article for CEP, the inductive analysis described in Chapter 3 was too detailed. However, from it, I was able to learn that quotations from experts would need to be a major part of my article, and that images tended to be pictures and conceptual figures, rather than tables or graphs. I also learned that the article would need to have an active purpose: it would not be enough to say ‘look at how unique rare earths are, here are some examples of applications.’ Rather, I would need to determine what aspects most affected chemical engineers, and what actions they could take in relation to them, and structure my article around those instead.

I therefore followed the study with a much more simple analysis of two CEP articles that would be similar in style to the article I was writing: *Metamaterials* and *World of Wireless*. For these articles, I counted the number of experts quoted, tracked how many and what types of images were used, and looked at average paragraph length by number of sentences and average article length by number of paragraphs. From this analysis, I found that I would need to conduct interviews with at least 6-8 experts, and that the images in my article would need to relate to the content of those interviews.

To conduct the interviews for my article, I first researched rare earth elements so that I would know about the most current developments in the field and be able to understand the basics I would need to know to work with the experts effectively. From this research, I developed a preliminary outline so I would know what sorts of topics I wanted to cover in my article. I then identified a list of potential interview participants by searching for online articles

about rare earths in financial investment publications, technical magazines like Popular Mechanics, and rare earth conference records. I sent interview requests to several experts and composed a rough interview script that I adapted as the interviews progressed. After all the interviews were conducted, I revised my outline and reviewed the recordings to determine the best approach to write my draft. This outline is presented in Appendix C, with some notes about parts from my interviews to include.

From the work, I was able to gather information about 5 specific features to include in my article:

- Expert quotations
- Metaphors
- A Progressive Outlook
- Current Challenges
- The Role of Chemical Engineers in the Challenges

The first three features are more popular than academic, as I would have expected for an overview article. Clearly, as I am not a content specialist in rare earths, I would need to include the thoughts of people who were. Interestingly, through the interviews I was also provided with images for the article that the content specialists had used or seen used in conferences on rare earths. These included pictures of separation processes and simplified diagrams of how the process works. They also provided me with some metaphors, which, due to my research, I knew I could incorporate in strategic ways.

Metaphors, described in the popular features section, would also help me to explain this highly technical area to chemical engineers who may not be as familiar with rare earths. From my interviews, I gathered two useful metaphors to include- rare earths as the “vitamins of modern engineering,” from Professor Rod Eggert, and “I’m like a 5 year old, and my toy box is rare earths,” from Karl Gschneider. The first quote would allow me to explain the relevance of rare earths in a more accessible way. The second would allow me to personalize the work of a highly technical DOE scientist in a way that readers could connect with.

Further, from reading these types of overview articles, I was able to notice how they all seemed to end on a positive note that pointed toward future development. This angle is one of the features that I cited from Hiller Kreighbaum in my popular scientific research as being found in not only the very first public scientific newspaper article, but also as a continuing trend. Clearly, this trend seems to have become an important part of overview trade journal articles, as well.

The last two features speak more to that instructional, yet more active than textbook tone that I described in the Broad Concerns of Industry section. It would not be enough to detail the challenges the industry faces without talking about what’s being done to solve them, and in particular what role chemical engineers could play in solving them. This emphasis on the role of chemical engineers seems to be a different representation of the “local angle” Kreighbaum argues that popular scientific articles include. However, instead of a geographic location, as is more relevant to larger numbers of a popular audience, chemical engineering trade journals can focus on the role of chemical engineers, thus also making their pieces more relevant to more members of their specialized audience than a geographic location could. I plan to accomplish this by discussing the current difficulties of process separation and how new technologies are being

developed to improve it, as well as new methods of recycling and alternative technologies to further address supply concerns.

Through my work I was able to define the chemical engineering trade journal genre as a hybrid genre that included elements of the academic, popular, and textbook scientific genres while differentiating itself from these genres through its industry specific concerns and objectives. I was able to support my findings with specific examples from the inductive study that I had conducted of 9 trade journal articles. These findings did not only guide the writing process for my article, but made me more aware of the distinctions between different genres of scientific communication. I am confident that this increased awareness will help me become a better producer and consumer of texts in my professional field in the future.

Future Work

Though my work serves as a strong starting point for work in this genre, there are many more opportunities for future work in this area. Although I looked at the very beginnings of the academic and popular genres of scientific communication, I did not examine the beginning of the chemical engineering trade journal. The limitation of my study to 3 recent years left me unable to make any claims about how this genre may have evolved over time, particularly in relation to the academic genre it may have come from or the popular genre it may have sought to adapt toward. Therefore, future work in this area should trace more history, to see how these genres of scientific communication evolved in relation to each other.

In my methods section, I discussed extending the rhetorical triangle to include history and gatekeeping in order to address the relationships between a discourse community and its texts. However, I briefly reviewed elements of these features for the other genres, and was not able to

address these elements for the trade journal in the context of the study I conducted, which focused more on form than community values. In order to address these areas, more work examining the discourse community of the trade journal is needed. I identified some primary and secondary audiences and some purposes for reading and writing these articles. To further this work, studies should be conducted to assess audience reception to these articles- How effective is this structure? Do readers understand the material? Do they act on it in their careers? Studies should also be conducted with authors to learn more about the process and motivations for writing these types of articles. Finally, trade journal editors should be interviewed to learn more about the editorial process for this genre and how it relates to the popular editorial process.

Works Cited

Alfred, Gerald; Brusaw, Charles; Oliu, Walter. *Handbook of Technical Writing*. 8th ed. Boston: Bedford/St. Martin's, 2006.

Alfred, Gerald; Brusaw, Charles; Oliu, Walter. *The Business Writer's Handbook*. 9th ed. Boston: Bedford/St. Martin's, 2009.

Bawarshi, Anis. "The Genre Function." *College English* 62.3 (2000): 335-60.

Bazerman, Charles. *Shaping Written Knowledge: The Genre and Activity of the Experimental Article in Science*. Madison, Wisconsin: U of Wisconsin P, 1988.

Berkenkotter, Carol, and Thomas N. Huckin. *Genre Knowledge in Disciplinary Communication: Cognition/Culture/Power*. Hillsdale, N.J.: L. Erlbaum Associates, 1995.

Carpenter, Monica Lynn, and Randall S. Upchurch. "A Five-Year Content Analysis of Articles in the American Resort Development Association's Developments Magazine (2002–2006)." *Journal of Retail & Leisure Property* 7.2 (2008): 149-60.

de Semir, Vladimir. "Scientific journalism: Problems and Perspectives." *International Microbiology* 3.2 (2000): 125-28.

Devitt, Amy J. "Integrating Rhetorical and Literary Theories of Genre." *College English* 62.6 (2000): 696-718.

Dunwoody, Sharon. "Scientists, Journalists, and the Meaning of Uncertainty." *Communicating Uncertainty: Media coverage of New and Controversial Science*. Mahwah, NJ, US: Lawrence Erlbaum Associates Publishers, 1999 (59-79).

Elbow, Peter. "Reflections on Academic Discourse: How It Relates to Freshmen and Colleagues." *College English* 53.2 (Feb., 1991): 135-55

Fishelov, David. *Metaphors of Genre: The Role of Analogies in Genre Theory*. University Park, PA: Pennsylvania State U P, 1993.

Foss, Sonja K. "Rhetorical criticism: Theory and practice." 3rd ed. U of Michigan: Waveland Press (2004).

Gluch, Pernilla, and Ann-charlotte Stenberg. "How Do Trade Media Influence Green Building Practice?" *Building Research & Information* 34.2 (2006): 104-17.

Goldsmith, Maurice. "The Science Critic." *A Critical Analysis of the Popular Presentation of Science, London*. Worcester: Billing & Sons Ltd, (1986).

Gopen, George, and Judith Swan. "The Science of Scientific Writing: If the Reader is to Grasp What the Writer Means, the Writer Must Understand What the Reader Needs." *American Scientist* 78.6 (1990): 550-58.

Hackett, Edward J., and Daryl E. Chubin. "Peer Review for the 21st Century: Applications to Education Research." *A National Research Council Workshop on Peer Review of Education Research Grant Applications: Implications, Considerations, and Future Directions*, February. 2003.

Kim, Jung Seob; Singh, Navneet. "A Novel Equation for Isothermal Pipe Flow." *Chemical Engineering* 119. 6 (Jun, 2012): 66-70

Kriehbaum, Hiller. *Science and the Mass Media*, New York: New York U P: 1967.

Lestina, Thomas G, PE. "Selecting a Heat Exchanger Shell." *Chemical Engineering Progress* 107. 6 (Jun, 2011): 34-38.

Mahoney, Michael J. "Scientific publication and knowledge politics." *Journal of Social Behavior & Personality* (1987).

McCabe, W.L. and Smith, J.C., *Unit Operations of Chemical Engineering* New York: McGraw-Hill, 2001.

Mikulak, Anna. "Mismatches Between 'Scientific' and 'Non-Scientific' Ways of Knowing and Their Contributions to Public Understanding of Science." *Integrative Psychological and Behavioral Science* 45.2 (2011): 201-15.

Miller, Carolyn R. "Genre as Social Action." *Quarterly Journal of Speech* 70.2 (1984): 51-167.

Nelkin, Dorothy. *Selling Science: How the Press Covers Science and Technology*. New York: Freeman, 1987

Peláez, Antonio López, and José Antonio Díaz. "Science, Technology and Democracy: Perspectives About the Complex Relation Between the Scientific Community, the Scientific Journalist and Public Opinion." *Social Epistemology* 21.1 (2007): 55-68.

Penrose, Ann M., and Steven B. Katz. *Writing in the Sciences: Exploring Conventions of Scientific Discourse*. New York: St. Martin's Press, 1998.

Shelly, Suzanne. "Preventing Dust Explosions: Are You Doing Enough?" *Chemical Engineering Progress* 104. 3 (Mar 2008): 8-14.

Shinn, Terry, and Richard P. Whitley. *Expository science: Forms and functions of popularisation*. Vol. 9. D Reidel Publishing Company, 1985.

Siler, Megan N. *Telling the Story of Women's Contributions to Public Relations: A Content Analysis of Three Public Relations Industry Publications, 2001-2005*. Diss. Ball State University, 2009.

Swales, John M. "Genre analysis: English in academic and research settings." (1990).

Ukil, Tamagna; Mathew, Thomas. "Reduce Gas Entrainment in Liquid Lines." *Chemical Engineering* 118. 6 (Jun, 2011): 42-44.

Winsor, Dorothy A. *Writing like an engineer: A rhetorical education*. London: Routledge, 1996.

Appendix A: Coding Sheets

Publication Title/Yr:	Article Title:										
Subsection 1	Subsection Title:										
	1	2	3	4	5	6	7	8	9	10	11
Word Count per Paragraph											
Sentence 1											
Sentence 2											
Sentence 3											
Sentence 4											
Sentence 5											
Sentence 6											
Sentence 7											
Sentence 8											
Sentence 9											
Sentence 10											
Sentence 11											
Sentence 12											
Sentence 13											
Sentence 14											
Sentence 15											
Sentence 16											
Sentence 17											
Sentence 18											
Sentence 19											
Sentence 20											
Total Words/Paragraph	0	0	0	0	0	0	0	0	0	0	0
Total Sentences/ Paragraph	0	0	0	0	0	0	0	0	0	0	0
Average Sentences/Paragraph	#DIV/0!	#DIV/0!	#DIV/0!	#DIV/0!	#DIV/0!	#DIV/0!	#DIV/0!	#DIV/0!	#DIV/0!	#DIV/0!	#DIV/0!

Figure 14: Stylistics Coding Sheet

Analyzing Trade Journals – Article Coding Sheet

Journal Name/Year: _____ Coded By: _____

Article Title: _____ Coding Date: _____

- Article Type: Global/News Maintenance & Operations Safety
 Computational Methods/Plant Technology Process Analysis
 Design → Environmental Business Operations → Career
 Other: _____
-

Author (s)

Location of Name

- In Table of Contents
 In Article beginning end

Rel. size of Name:

(Write < or > in the box)

Author text Subtitle text

Author text Article text

Other: _____

Info & Credentials

- None → Editor
 Company → Position
 Bio → Length _____ words
 Contact info (email)
 Other _____
 Position/ #Yrs Experience

 Degree? _____
 From? _____
 Published? # Publications _____

Sources

Listed _____

Type

Academic _____ # This Journal _____

Other Journal _____ # Textbook _____

Other

Layout

Title Size *(draw relative to page)*



Title Color: _____

Subtitle: _____

Images

Total # Images _____

Advertisements _____

Related to author's company _____

Figure 15: Overall Coding Sheet

Analyzing Trade Journals – Article Coding Sheet

Read the article. Pay close attention to the author's grammatical complexity, metaphors, and use of lists. If more space is needed for any fill-ins, simply use the back. Be sure to indicate each extra fill-in with its appropriate letter for identification purposes. As you read, do the following:

- A. Jargon:** Highlight jargon in green. **Jargon is industry-specific terminology or common words used in a specifically different way by this industry.** Highlight any definitions you find for these terms in green as well.
- B. Other Definitions:** Highlight any other definitions you find in yellow.
- C. Metaphors/Similes:** Highlight metaphors and similes in blue. Make sure to highlight the whole phrase, at least 6 words.
For each of the metaphors/similes highlighted, what do you think the author was trying to accomplish by using it? (**Ex. Simplify, clarify, or add flourish to a concept**)

Page # ___ ¶# ___ Purpose: _____
Page # ___ ¶# ___ Purpose: _____
Page # ___ ¶# ___ Purpose: _____
Page # ___ ¶# ___ Purpose: _____
Page # ___ ¶# ___ Purpose: _____

- D. Anecdotes/Jokes:** Highlight anecdotes and jokes in pink. You may draw a box around the whole section if it is larger than 3 sentences.
For each of the anecdotes/jokes highlighted, what do you think the author was trying to accomplish by using it? Please fill these out in the order in which they appear in the article.

1. _____
2. _____
3. _____

- E. Examples (not in list format):** Highlight examples in orange, unless part of a list. If the example is in an anecdote/metaphor, be sure to use both colors. Next to the example, indicate what type of example it is in the text by marking:

- **A** for examples of applications
- **C** for conceptual examples
- **O** for other. Describe the type of example below. If there are two 'other' types of examples in a single column, indicate this by writing "1.1, 1.2, ect." on the column # line:

Page # ___ Column # ___ Type: _____
Page # ___ Column # ___ Type: _____

Figure 16: Detailed Coding Sheet (5 pages)

Analyzing Trade Journals – Article Coding Sheet

Page # ___ Column # ___ Type: _____

Page # ___ Column # ___ Type: _____

Page # ___ Column # ___ Type: _____

Page # ___ Column # ___ Type: _____

Page # ___ Column # ___ Type: _____

F. Grammatical Complexity: Indicate the overall level of grammatical complexity for the article by circling the appropriate number on the 1-6 scale below.



Example of 1: “I am a cat with a nice purr.”

Example of 6: “I find myself befitting of the most sought-after feline qualities: blessed am I with the ability to produce an emission of the most heavenly sounds from my well-fed, furry belly.”

1 2 3 4 5 6 What qualities of the sentences make you feel that overall, the article is/isn't grammatically complex? Check all that apply. Specify any others.

Introductory clauses

Use of jargon

Compound sentences

Nominalization of verbs

Use of dashes

Lengthy sentences

Other: _____

G. In-text References: Underline quotations in blue pen. Fill out the information below.

For each, mark whether it is a quotation, paraphrase, or part of a citation chain. Then indicate location by paragraph number and length by number of words. Also indicate who or what the quote is from and why you think the author included the quotation. (**Purposes could include: credibility, argument, instruction, elaboration, etc.**)

Quotation 1: Quotation Paraphrase Citation Chains

¶# ___ # Words ___ Source: _____

Purpose: _____

Quotation 2: Quotation Paraphrase Citation Chains

¶# ___ # Words ___ Source: _____

Purpose: _____

Analyzing Trade Journals – Article Coding Sheet

Quotation 3: Quotation Paraphrase Citation Chains

¶# ___ # Words ___ Source: _____

Purpose: _____

Quotation 4: Quotation Paraphrase Citation Chains

¶# ___ # Words ___ Source: _____

Purpose: _____

Quotation 5: Quotation Paraphrase Citation Chains

¶# ___ # Words ___ Source: _____

Purpose: _____

Quotation 5: Quotation Paraphrase Citation Chains

¶# ___ # Words ___ Source: _____

Purpose: _____

H. Bullets/Lists: As you read the article, notice any instances of bullets or lists. For each instance, indicate the location and number of bullets and bullet type below.

Page# ___ Column # ___ # of Bullets ___

Type: Elaborative Mathematical Examples Instructive

Other _____

Page# ___ Column # ___ # of Bullets ___

Type: Elaborative Mathematical Examples Instructive

Other _____

Page# ___ Column # ___ # of Bullets ___

Type: Elaborative Mathematical Examples Instructive

Other _____

Page# ___ Column # ___ # of Bullets ___

Type: Elaborative Mathematical Examples Instructive

Other _____

Page# ___ Column # ___ # of Bullets ___

Type: Elaborative Mathematical Examples Instructive

Analyzing Trade Journals – Article Coding Sheet

Other _____

I. Conclusion: What is the author trying to accomplish in the conclusion?

Check the box next to all purposes that apply. Then indicate conclusion length below.

Author repeats main ideas of the article

Author elaborates on the next step or steps

Author cautions audience about something

Other _____

Conclusion length: # paragraphs ____ # sentences ____

J. Call-outs: For each instance of called-out text, fill out the following:

Text color: _____ # Words ____ Purpose: Hook Emphasize main point

Other _____

Text color: _____ # Words ____ Purpose: Hook Emphasize main point

Other _____

Text color: _____ # Words ____ Purpose: Hook Emphasize main point

Other _____

K. Thesis statement: Find the thesis statement of the article and indicate its length and location below.

Sentences _____ Page # _____ ¶# _____ Absent?

Write the thesis statement below. If none, specify none, then write what you think the thesis statement is.

Does the thesis statement:

Rely on problem statement

If yes, write problem statement: _____

Indicate the tone of the thesis statement by checking the boxes below.

Argumentative

Explanatory

Other _____

Analyzing Trade Journals – Article Coding Sheet

L. Audience: Who do you think the intended audience for this article is? Be specific.
(Ex. “Managers of chemical plants that have decision-making power” or “Operators of chemical plants that do not have decision-making power”)

M. Rhetorical Purpose: What do you think the author is trying to make the intended audience think, feel, or do?

Analyzing Trade Journals – Image Coding Sheet

Journal Name/Year: _____ Coded By: _____

Article #: _____ Image #: _____ Coding Date: _____

Image Type: *(Check the box of the category or categories that best describe the image type)*

- | | | |
|--|---|---|
| <input type="checkbox"/> Diagrams
<input type="checkbox"/> Flow
<input type="checkbox"/> Chem. Process
<input type="checkbox"/> Concept
<input type="checkbox"/> Trees
<input type="checkbox"/> Decision
<input type="checkbox"/> Classification | <input type="checkbox"/> Graphs
<input type="checkbox"/> Line
<input type="checkbox"/> Bar
<input type="checkbox"/> Other: _____
<input type="checkbox"/> Charts
<input type="checkbox"/> Pie
<input type="checkbox"/> Other: _____ | <input type="checkbox"/> Screenshot
<input type="checkbox"/> Graphics
<input type="checkbox"/> Advertisement
<input type="checkbox"/> Photograph
<input type="checkbox"/> <u>Infographic</u>
<input type="checkbox"/> Clipart/Other graphic: _____ |
|--|---|---|

If other, describe: _____

Is the image: Labeled Showing movement Cross-section

Comparative: # Images ____



In the box, please draw the image size relative to page and column.



Is the image in a text box?
(Draw the image relative to the text box, including any other images in the text box.)

(For all image types, fill out the information below)

Standard Colors ____ List the colors: _____

Numbered as figure?

Caption # Words ____

Caption is: Descriptive Argumentative Words: _____

Jargon: _____

Separate Title # Words ____

If applicable, Title is: Descriptive Argumentative Words: _____

Jargon: _____

Figure 17: Image Coding Sheet (2 pages)

Analyzing Trade Journals – Image Coding Sheet

What is the purpose of this image? (2 sentences or less): _____

Source listed Additional embedded information: Describe how and for what purpose: _____

Is it ethical?

Overall impression, 6 most ethical, 1 most unethical: 1 2 3 4 5 6 Why? _____

Where referenced? Adjacent column Same page Adjacent page Other _____

How referenced? Numerical Descriptive None Other _____

If Picture/Graphic:

Descriptive of concept Descriptive of object Argumentative

If Graph:

Axes ___ Color: x-axis _____ y-axis _____ other axis _____ title/caption _____

If Table:

Words in Title ___ Title is: Descriptive Argumentative Words: _____

Appendix B: Conference Poster

The Rhetoric of Trade Journals: An Analysis of Chemical Engineering Professionalization in Print

Melanie Laberge
Worcester Polytechnic Institute

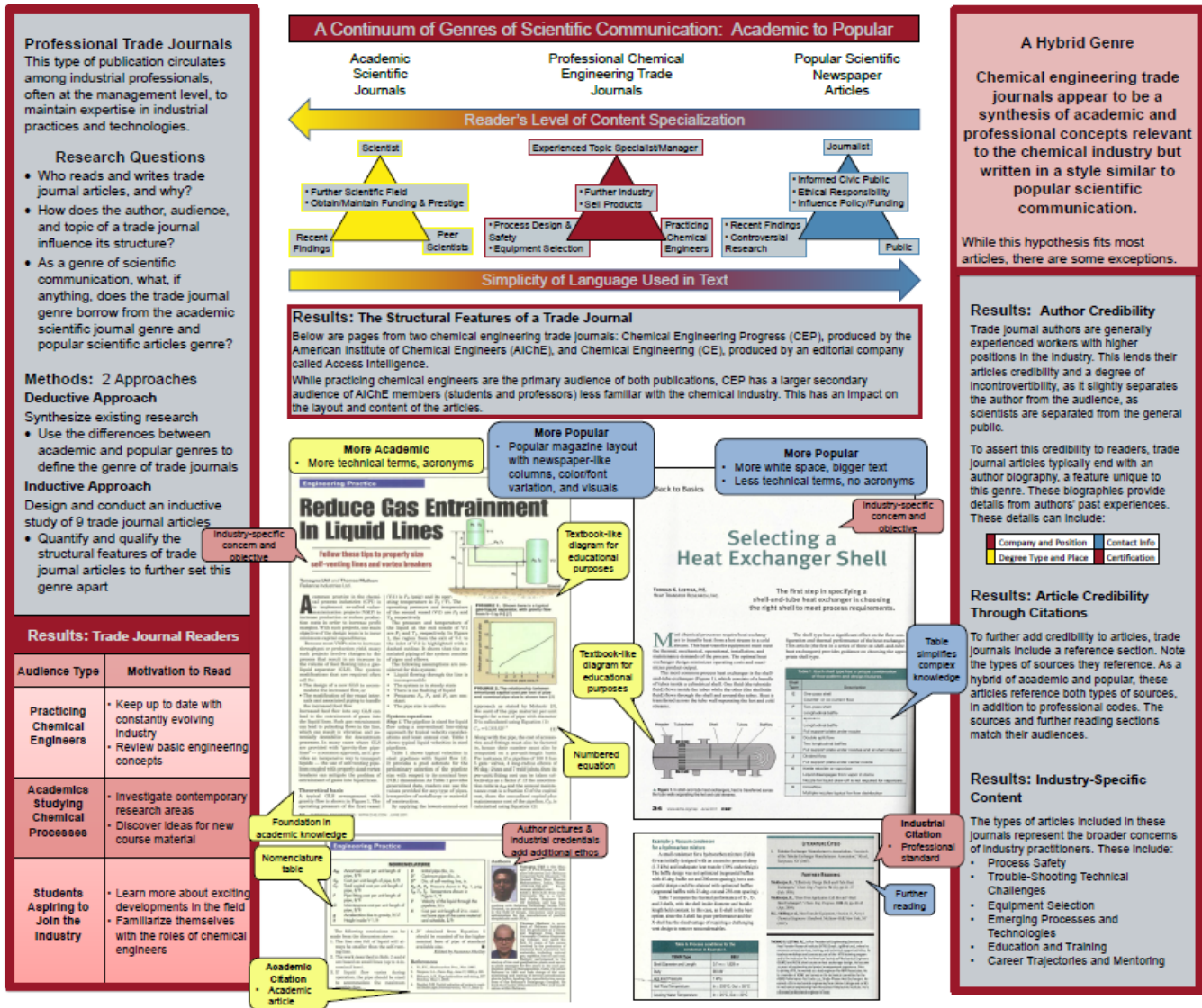

Figure 18: Conference Poster

Appendix C: Article Outline

Rare Earths:

- a) What they are
 - a. Enablers, ‘vitamins of modern engineering’-Gschneider
 - b. Total 17, this part of the periodic table, 4f gives unique properties: magnets, phosphors, catalysts
 - i. Light vs heavy
 - c. 5 critical for new energy- perhaps 2 most important for this Nd, Eu (magnets + phosphors) - Meijerink
 - d. Applications: magnets, phosphors, catalytic cracking!
- b) Challenges to rare earths
 - a. Found everywhere, but in varying compositions-must be processed
 - b. Difficult to process- not only contain radioactive U and Th, but also so close chemically, difficult to separate-particularly heavies.
 - c. Processes being used: list
 - i. Solvent extraction
 - 1. Lots of equipment, lots of water, lots of time, lots of byproducts - Mariano
 - d. Because its so difficult and costly, almost all heavy processing is in China
 - i. There were less strict environmental codes, they took over the market between 1985-200
- c) Moving forward
 - a. New separation technology
 - i. Gschneider-Ames lab, Lifton’s conference
 - b. New processing capacity
 - i. New mines- Eggert, but new processing in Quebec (Hatch)
 - c. Alternatives
 - i. Tradeoffs to substituting away, but can try to use less
 - d. Recycling
 - i. Not many magnets need recycling, still in use
 - ii. Promising, theres lots of rare earth concentrated in magnets – Harris’ work