

April 2015

Energy Absorbing Barrier

Jacob Daniel Ostling
Worcester Polytechnic Institute

Toby-Lian Edovas
Worcester Polytechnic Institute

Follow this and additional works at: <https://digitalcommons.wpi.edu/mqp-all>

Repository Citation

Ostling, J. D., & Edovas, T. (2015). *Energy Absorbing Barrier*. Retrieved from <https://digitalcommons.wpi.edu/mqp-all/2606>

This Unrestricted is brought to you for free and open access by the Major Qualifying Projects at Digital WPI. It has been accepted for inclusion in Major Qualifying Projects (All Years) by an authorized administrator of Digital WPI. For more information, please contact digitalwpi@wpi.edu.



WPI

Energy Absorbing Barrier
Project Number: CAB 1502
Advisor: Professor Christopher A. Brown

Authors

Toby-Lian Edovas
Jacob Ostling

This report represents the work of WPI undergraduate students submitted to the faculty as evidence of completion of a degree requirement. WPI routinely publishes these reports on its website without editorial or peer review. For more information about the projects program at WPI, please see <http://www.wpi.edu/academics/ugradstudies/project-learning.html>

Abstract

The objective of this project is to design an impact barrier that protects people in snow sports, and prevents them from going off the trail in falls. It has a focus on racing, as participants are at increased risk. To be useful in this area, there is an emphasis on rapid deployment and recovery. This barrier has value because many people get hurt in ski racing, and there are drawbacks to the current generation of barriers. Our design uses a net that catches people more reliably than the current generation. It also uses supporting poles that detach from the base, and elastic elements to stop people less violently. The barrier is stored and deployed on a reel that facilitates easy deployment and recovery.

Acknowledgements

We would like to thank:

Christopher A Brown, for his advising throughout this entire project

The International Society for Skiing Safety, for allowing us to present at their conference in San Vito di Cadore, Italy, and for giving us a scholarship so that we could attend

Patrick Wall, for help in testing our barrier

WPI Mechanical Engineering Department

Table of Contents

Abstract	1
Acknowledgements	2
Table of Figures	5
1. Introduction	6
1.1. Objective	6
1.2. Rationale	6
1.3. State of the Art	7
1.4. Approach	8
2. Decomposition: Selected Functional Requirement/Design Parameter pairs	10
2.1. Selected Constraints	10
2.1.1. Constraint 1	10
2.1.2. Constraint 2	10
2.2. FR 1: Limit Contact Pressure	10
2.2.1. DP 1: B-net Mesh	10
2.3. FR 2: Protect from hazardous objects behind barrier	11
2.3.1. DP 2: Stabilizing Poles	11
2.4. FR 3: Catch Individual	11
2.4.1. DP 3: Concave Net	12
2.5. FR 4: Limit Acceleration	12
2.5.1. DP 4: Energy Absorbing Device Assembly: Elastic Zones	12
2.6. FR 5: Rapid Set-Up and Take-Down	12
2.6.1. DP 5: Reel and Recovery-System assembly	13
3. Design Results	14
3.1. Elastic Zones	17
3.2. Removable Reel	17
3.3. Detachable Base Poles	18
4. Computations	19
5. Preliminary Testing	22
5.1. Methods	22
5.2. Testing	23

5.2.1.	Tightly Hung B-net.....	23
5.2.2.	Loosely Hung B-net.....	24
5.2.3.	Modified B-net.....	25
5.2.4.	Preliminary Test Conclusions.....	25
6.	Discussion.....	26
6.1.	Accomplishments.....	26
6.2.	Critical Assessment of the Design.....	26
6.3.	Constraints.....	27
6.4.	Impact.....	27
6.5.	Improvement Over B-net.....	27
6.6.	Commercial Viability.....	27
6.7.	Critical Assessment of Design Method.....	28
6.8.	Future Work.....	28
7.	Conclusion.....	30
7.1.	Accomplishments.....	30
7.2.	Critical Assessments.....	30
7.3.	Remaining Issues.....	30
8.	References.....	31
9.	Appendices:.....	32
	Appendix A: Crash Survivability Figures.....	32
	Appendix B: Protection Barrier for Ski Tracks.....	34
	Appendix C: Full Acclaro Decomposition.....	36

Table of Figures

Figure 1: B-net at the site of an earlier accident resulting in paralysis (photo credit to Professor Christopher Brown)	6
Figure 2: A-net manufactured by Retificio Ribola	7
Figure 3: B-net deployed in three layers	8
Figure 4: Diagram of the design result	14
Figure 5: Proof of Concept Barrier	15
Figure 6: Elastic Zone Close-up	16
Figure 7: Left: Unloaded Elastic Zone. Right: Loaded Elastic Zone	17
Figure 8: Crash Forces on Standard B-net	20
Figure 9: Impact Diagram	20
Figure 10: Crash Forces on Modified B-net	21
Figure 11: Test 1, a tightly hung net similar to how the current generation of B-nets is set-up ..	22
Figure 12: Test 2, a loosely hung net with about 0.25 meters of slack	22
Figure 13: Test 3, modified B-net with the elastic zone	23
Figure 14: Maximum net stretch when hung tightly	24
Figure 15: Maximum net stretch when hung loosely	24
Figure 16: Maximum net stretch with modified B-net	25
Figure 17: Acceleration vs Time (Shanahan, 2004)	32
Figure 18: Acceleration Injury Criteria (Shanahan, 2004)	32
Figure 19: Finite Element Analysis (Gourniat, 2008)	33
Figure 20: Strain Energy vs Tensile Elongation (Gourniat, 2008)	33
Figure 21: Impact Acceleration vs Time (Gourniat, 2008)	33
Figure 22: European Patent 1 438 995 A1	34
Figure 23: European Patent 1 438 995 A1	35
Figure 24: Full Energy Absorbing Barrier Decomposition	36

1. Introduction

1.1. Objective

The objective of this project is to design an impact barrier that protects people in snow sports, particularly racing, by preventing them from going off trails and colliding with fixed objects. As such, it has an emphasis on easy deployment and recovery.

1.2. Rationale

Skiing and snowboarding are responsible for an average of forty deaths and forty-nine serious injuries per season in the United States (NSAA Fact Sheet 2013). Ski and Snowboard racers who travel at higher speeds than average participants, often on iced courses, are subject to increased risks (Flørenes, T W 2009). A fall at these speeds often leads to sliding off the course into hazards, such as trees. While this can be mitigated by the presence of current barriers, there are gaps in their ability to catch people. Temporary barrier's issues stem from difficulty in set up and unreliable performance. Permanent barriers are expensive, and are not deployed in many cases where they would be useful. There is a valid need for a barrier that addresses these concerns.



Figure 1: B-net at the site of an earlier accident resulting in paralysis (photo credit to Professor Christopher Brown)

1.3. State of the Art

There are two barriers in widespread use: A-net and B-net. A-net is anchored permanently in the ground with poles along the slope. It is generally effective in absorbing impact energy, and preventing injuries, in collisions. Studies conducted on A type net using an anthropomorphic dummy showed it to be effective in collisions at 60 km/h (Petroni et al, 2010). Additional finite element analysis on A-net found injury criteria were below limits in impacts up to 80 km/h (Anghileri et al, 2014).



Figure 2: A-net manufactured by Retificio Ribola

B-net is temporarily anchored in the ground with poles that pull out of the snow at unpredictable loads. These can have smooth bases, brush bases, or screw bases which have varying coefficients of friction against snow. It is less expensive than A-net but takes significant time and effort to deploy. B-net is most often used in snow-sports races, and normally deployed in multiple layers.



Figure 3: B-net deployed in three layers

We were unable to find any empirical research into differences between A and B-net, in terms of the forces involved in collisions. We concluded that B-net is less capable of safely stopping a crashing person, by comparing video footage of crashes involving B-net, under race conditions, to studies on A-net. Differences in masses, elastic moduli, and yield stress are partially responsible for the differences in performance (Gourinat and Lapoujade, 2014). The flexibility and movement of barrier pole under impact is also a contributing factor

An existing design for a Protection Barrier for Ski Tracks (Giamperio, 2004) adds folded pockets to netting. These are held closed with rubber bands, or similar mechanisms which open if the barrier experiences a violent shock. This extends the duration of impact, and lowers onset of loading. The barrier is intended to prevent skiers from going off the trail, and into a “danger zone”. Figures are included in Appendix B.

In order for a collision to be safe, acceleration, jerk, and contact pressure need to be limited. The magnitude, direction, and duration of acceleration determine whether it is dangerous to humans. A high rate of onset can make acceleration more dangerous (Shanahan, 2004). Criteria for injury, based on G-forces, are elaborated in Appendix A.

1.4.Approach

The project barrier was designed following the two rules of Axiomatic Design: maintain the independence of the functional requirements and minimize the information content.

This design will advance the state-of-the-art by having a more reliable protection from hazardous objects along a slope, and less violent collisions with barriers. The barrier use elastic elements to lower the rate of loading on crashing people relative to standard B-net. It uses these zones in concert with vertical slack to form a concave under impact, and prevent people from slipping or rolling past the net. It also has modified poles that detach from their base at a set level of work, resulting in more predictable impacts, and mitigating the tendency of B-net to bend over when hit due to the bending moment about its base. We maintained a focus on the functional properties of the barrier over the design parameters throughout this project.

After constructing a proof of concept barrier, we performed preliminary tests on it with a pendulum weight, versus standard B-net. A scientific and repeatable trial was beyond the scope of this project, but based on our initial results, the modified B-net consistently had a longer impact time, and greater displacement under load. Our barrier advances the state of the art for snow sports barriers, by proposing a simple set of upgrades on the current generation of B-net that would make it safer.

In the following report we will explain our full decomposition with the functional requirements and their accompanying design parameters. In the following results section, the design of the modified barrier will be described in detail. This section includes a diagram showing the design parameters that satisfy the functional requirements. Next, the energy absorption and forces involved in collisions with the barrier are described symbolically, and compared to standard B-net. The testing section describes methods we used to test the improved barrier with the current state-of-the-art. This report ends with a discussion on alternate devices and mechanisms that could be used in the modified barrier, and concluding remarks on the major design elements and a critical assessment of the design.

2. Decomposition: Selected Functional Requirement/Design Parameter pairs

2.1. Selected Constraints

In addition to its general functional requirements, we imposed a set of constraints on the barrier to ensure its performance. These were primarily focused on the barrier's user environment.

2.1.1. Constraint 1

The barrier should perform consistently regardless of snow strength, temperature, and other conditions such as icing. There are many different types of ski slopes and seasonal conditions that the barrier would be exposed to, and it should have predictable and non-injurious deceleration in all impact cases. This is especially important with regard to the work needed to pull poles out of the snow; that is integral to barrier function, and can be directly affected by snow conditions and temperatures.

2.1.2. Constraint 2

The barrier's performance should not materially decrease due to impacts over its lifetime. This would have obvious negative effects on the usefulness of the barrier.

2.2.FR 1: Limit Contact Pressure

A necessary function of the barrier is to prevent injurious levels of contact pressure when stopping a crashing person, as these can result in blunt force trauma. Furthermore, the barrier should not break from the force of the crashing individual. The current generation of B-net fulfills both these requirements. It spreads the reaction force along many squares of the mesh by conforming to the object in contact. We were unable to find any record of injury due to impact with 5 centimeter B-net mesh itself. Additionally it does not break in most impacts unless cut by a ski or snowboard.

2.2.1. DP 1: B-net Mesh

We are using standard 5 centimeter B-net mesh in our barrier design. As stated above, it rarely breaks during impacts, and does not cause injury. Using standard B-net material also minimizes transition costs. There are already manufacturers producing material, and potential customers for an improved barrier have existing stocks. This should mean less resistance and minimum costs to consumers adopting the new barrier.

2.3. FR 2: Protect from hazardous objects behind barrier

One of the key functions of the barrier is to prevent collision with hazardous objects behind it. These can include anything from trees, to lift towers, to snow banks. To do this, the barrier should be anchored to the snow, preventing it from moving freely once a crashing individual hits. In the current generation of B net this is done with flexible PVC poles along the barrier's length, which can bend over during impact.

2.3.1. DP 2: Stabilizing Poles

Our design to anchor the barrier uses modified B-net poles, which detach from their bases at a set amount of work. Detaching from the base should prevent the barrier from being knocked down when hit, as there is no longer a fulcrum where the pole meets the snow. The net is attached to these poles through plastic hooks at the top and bottom, in the same way as standard B-net. The poles are in turn driven into the snow. They are placed equidistantly along the length of the barrier. They use screw bases in the snow to reliably hold firm until the detachment mechanism activates. Screw bases need a hole drilled in the snow to insert, but are less labor intensive than some other means such as brush bases.

We did not complete a design for the detachment mechanism of the modified B-net poles, but considered several possibilities. One method was an interference fit between a rubber bulb on the base of the pole, and an O-ring in the top of the base. While simple, the interference fit would take different levels of work separate depending on the angle of applied force. Additionally, due to the nature of rubber, it could become brittle and break at the low temperatures found on ski slopes. This mechanism could be a suitable subject for a future project.

2.4. FR 3: Catch Individual

Another central function of the barrier is to stop people from going under or over the net during a crash. Once a person hits the net, they should not slip out. This is an issue with current B-net designs, especially with tightly hung net. When there is little slack, the net may not “wrap around” a crashing person, and poles can pull out too early. As part of this requirement it is also necessary to keep the barrier even with the ground. This can be challenging in the uneven terrain frequently present on ski hills. The barrier should also maintain its structure, before and after impact. Current B-net poles are suitable for this before impact, but as stated earlier, have a tendency to bend over after being hit.

2.4.1. DP 3: Concave Net

Our projects solution to catching individuals is to hang the net so that it forms a pronounced concave shape during an impact. This encourages the net to wrap around a person who hits it, and makes it difficult for them to roll over or under. This is accomplished by hanging the net with vertical slack. In concert with the horizontal elastic zones, this gives the center of the net more displacement than the outer areas. The barrier is given structure and kept even with the ground by detachable poles, which act in a similar capacity to standard B-net poles. Their primary difference is in continuing giving the barrier structure after impact. When standard B-net is hit, there is a bending moment on the base of the poles, from force applied by the net. This contributes to the net bending over, and losing its upright structure after impact. With detachable poles this fulcrum is gone, and this effect should be mitigated.

2.5. FR 4: Limit Acceleration

Rapid deceleration is a major cause of injuries in crashes, so it should be limited by our barrier. Acceleration is limited through the barrier's ability to absorb impact energy. The elastic properties of polyethylene net alone are not enough to do this. Thus, the modified barrier should have an additional means to absorb impact energy.

2.5.1. DP 4: Energy Absorbing Device Assembly: Elastic Zones

In order to limit acceleration during impacts, our design has elastic zones with a lower stiffness than the surrounding polyethylene net. These are attached to a scrunched area of net, such that the net is at its normal length when the elastic is full stretched. In an impact, these should stretch to their full length before the surrounding net stretches, and before the poles detach. These elastic zones should be placed between each set of detachable poles. Our proof-of-concept barrier used seven equidistant bungee cords, held to the net by hooks on their ends and zip ties. These were placed at two meter intervals along the barrier. It is possible to calibrate the rate of loading on a person impacting the barrier by varying the number and placement of these bungees.

2.6. FR 5: Rapid Set-Up and Take-Down

B-net takes a long time to set up, and can require a lot of labor. Each pole needs a hole drilled in the snow to insert, and hanging net is tedious. This is compounded by the multiple layers of B-net needed to protect parts of the course. In addition to the unnecessary effort, this limits the amount of B-net that can be set up prior to a race. That can become a safety concern

when limited manpower is available. Our modified B-net barrier should be easy to set up, and take down, quickly. This should not harm the ability for the barrier to be fixed after an impact mid-race.

2.6.1. DP 5: Reel and Recovery-System assembly

In order to rapidly deploy our barrier, it is stored on a reel with a square bolt on one end. The reel is a pole that the net is wrapped around, with a greater length than the net's height. The pole should extend past the net on both sides when it is wrapped up. For deployment the reel is put between two ring top stakes at the top of the slope. Somebody can then carry the end of the barrier to the desired position. After this the net is hung between the poles as usual. The major time saving factor here is the barrier's single layer.

During recovery the poles are pulled out of the ground, and the reel is placed back between the ring-top stakes. A cordless drill with a nut driver attachment is then used to rewind the net onto the reel. In the event that this fails, a torque wrench can be used to do this manually. Recovering the barrier horizontally should limit tangling, and make it easier to guide the net onto the reel. Once back on the reel, the barrier is easily moved and stored.

3. Design Results

A simplified barrier design is shown below. It is based of the functional requirements and design parameters described previously. Normal polyethylene B-net will still be used as the net material. Primary modifications include the elastic zones, detachable poles, and the removable reel on the upslope pole. There are also end poles at the top and bottom of the barrier. These are not be permanent, but will be driven further into the ground than the detachable poles. The end poles hold the barrier in place, in the event that all others are detached.

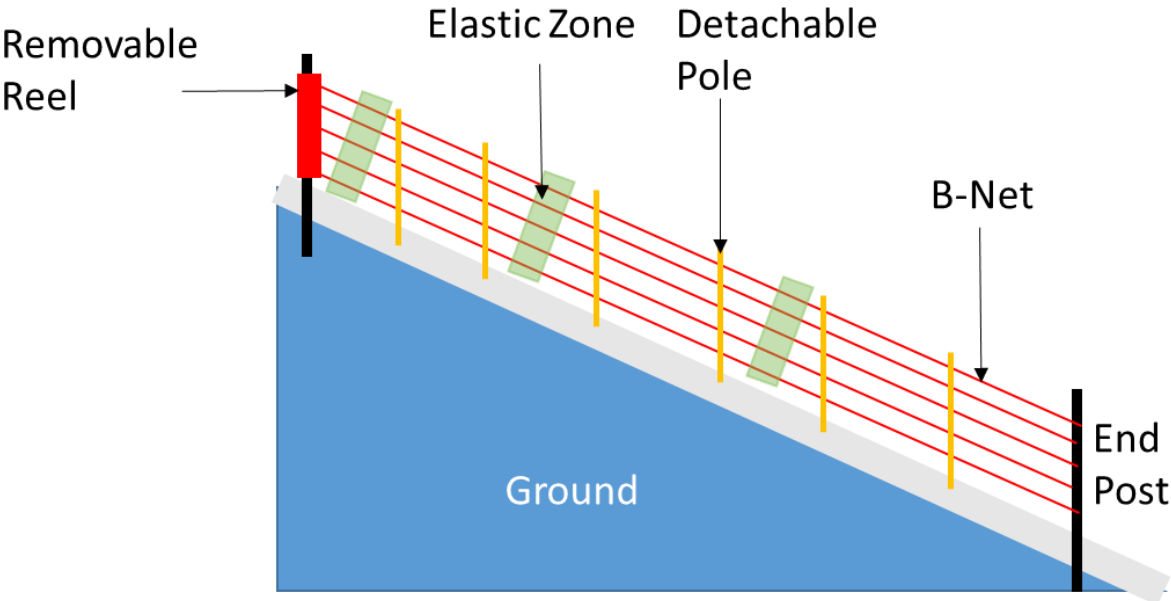

Figure 4: Diagram of the design result



Figure 5: Proof of Concept Barrier



Figure 6: Elastic Zone Close-up

3.1. Elastic Zones

The elastic zones in our proof of concept barrier were made with bungee cords as the active element. These were attached horizontally, in groups of seven, but vertical elements could be added for greater stiffness. We used a bungee cord with a low stiffness and relatively high elastic deformation region, to minimize the initial rate of loading in impacts. Approximately a meter of B-net was scrunched into the length of the unloaded bungee cord. The net is taut but unloaded when the bungee is stretched to its full length. The bungees were fastened with plastic hooks on their ends, and zip ties. When set up, there should be one elastic zone between each detachable pole. Examples of loaded and unloaded elastic zones are pictured below.

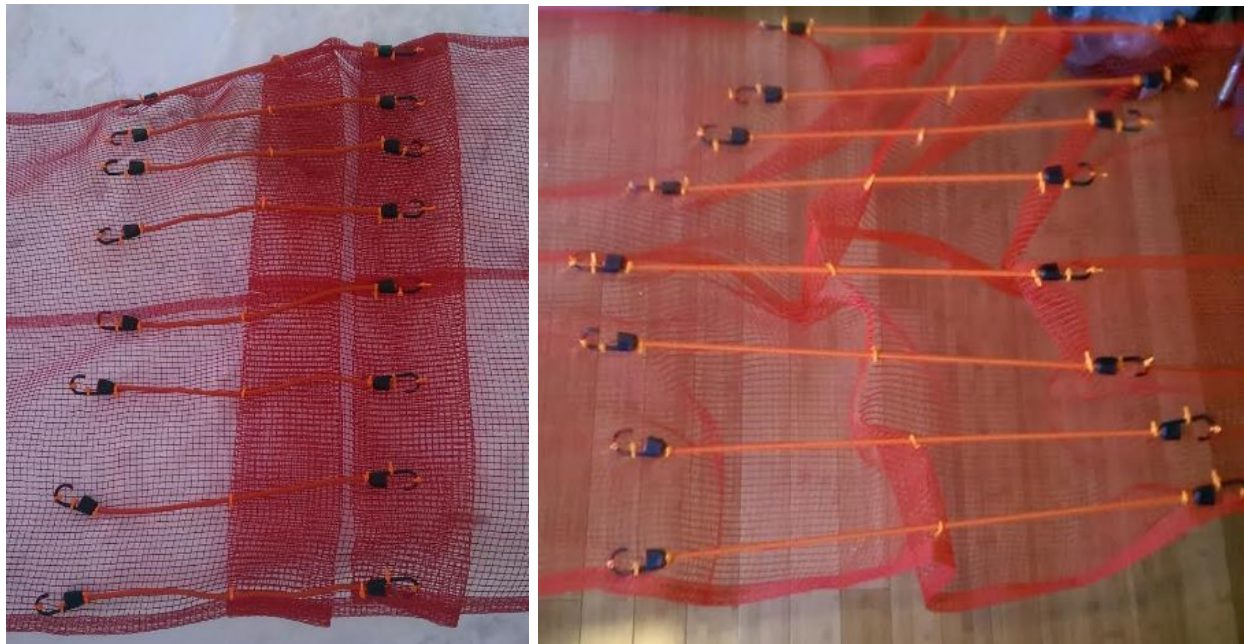

Figure 7: Left: Unloaded Elastic Zone. Right: Loaded Elastic Zone

3.2. Removable Reel

Our project's reel used a standard 22 mm square bolt. When not in use, the modified B-net can easily be rolled onto the reel and stored elsewhere. This allows for rapid set-up and take-down. Prior to a race, the reel is mounted on ring-top stakes, and the net is unwound as it is brought down the slope. When the net is mounted on both ends, all the poles between the ends are then driven into the snow. To take down the net, first all poles are taken out of the snow. To recover, the reel is then mounted horizontally back onto the stakes and the net is rewound using a

cordless drill on the square bolt. If a cordless drill is not available, a torque wrench can be used as a backup. The reel should decrease the man-hours needed to work on barriers before and after races.

3.3. Detachable Base Poles

As specified in the decomposition, another important modification is a detachable pole. These are placed at regular two meter intervals, threaded through the net. A design for a detachment mechanism was not completed in the course of this project. The modified pole should detach at the base of the pole, at a set level of work, during an impact. The detachment work level should be able to be calibrated. Detachable poles would prevent major bending about the fulcrum, keeping the barrier in front of a crashing person, instead of bending over.

4. Computations

The modified B-net barrier designed in this project would lower the initial rate of loading on a person during a collision. This in turn reduces acceleration and jerk, both of which are causes of injury (Shanahan, 2010). This is accomplished by the addition of elastic zones, and detachable poles to standard B-net.

A collision with standard B net can be viewed as an energy balance. The initial kinetic energy of the skier being equal to the final kinetic energy, plus the elastic potential energy of the polyethylene net, and the work to pull the poles out of the snow. In order to simplify the computation, it is assumed that the poles are rigid bodies. Air resistance, viscosity of the net, and the friction force of snow on the crashing person are also ignored. Taking the derivative with respect to displacement gives the force on the colliding person.

$$T_1 + V_1 + U_1 = T_2 + V_2 + U_2$$

$$T_{skier\ 1} = T_{skier\ 2} + V_{net} + U_{poles-snow}$$

$$\frac{1}{2}m_s v_{s1}^2 = \frac{1}{2}m_s v_{s2}^2 + \frac{1}{2}k_n s^2 + (\mu_k N s)$$

$$\frac{d}{ds} \left(\frac{1}{2} m_s v_{s1}^2 \right) = \frac{d}{ds} \left(\frac{1}{2} m_s v_{s2}^2 + \frac{1}{2} k_n s^2 + (\mu_k N s) \right)$$

$$F = k_n s + \mu_p N$$

The graph below gives an idealized representation of the load on a person during an impact with standard B-net. The first component is from the net. When viewed as an elastic mechanism, this force can be directly related to the material's stiffness, K. The second component comes from the work to pull the B-net poles out of the snow. This is based on the friction between the poles and the snow, and the normal force between them. In a real collision with B-net there is work being done pulling out poles, and stretching the net at the same time, but for the graph below they have been isolated

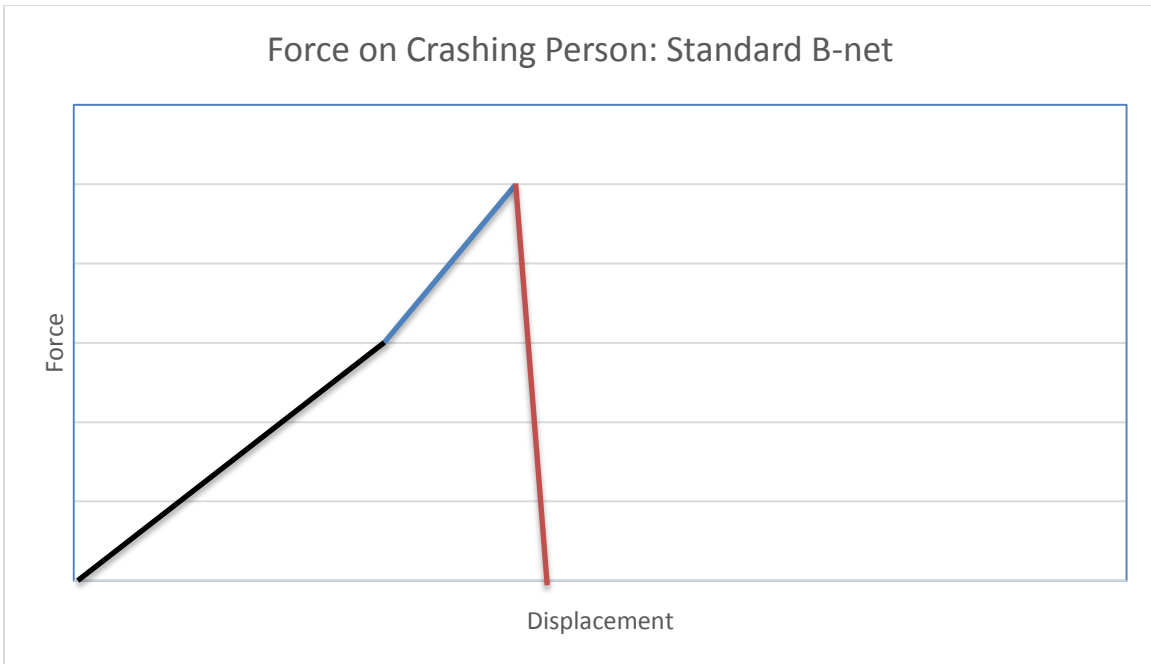

Figure 8: Crash Forces on Standard B-net

The elastic zones have a lower spring constant than the net that they are connected to. In an impact, they will absorb kinetic energy before the less elastic polyethylene net, lowering the initial force applied to the person. The modified poles also require less work to separate from their bases than the standard variant. Additionally, unlike the standard variant, each pole will separate at the same amount of work. As with the standard B-net, this is expressed as an energy balance below.

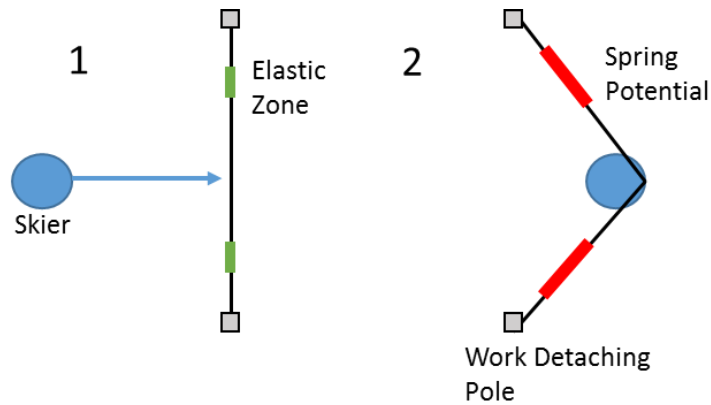

Figure 9: Impact Diagram

$$T_1 + V_1 + U_1 = T_2 + V_2 + U_2$$

$$T_{skier\ 1} = T_{skier\ 2} + V_{bungees} + V_{net} + U_{poles-detachable}$$

$$\frac{1}{2}m_s v_{s1}^2 = \frac{1}{2}m_s v_{s2}^2 + \frac{1}{2}k_b s^2 + \frac{1}{2}k_n s^2 + (\mu_k N s)$$

$$\frac{d}{ds} T_{skier\ 1} = \frac{d}{ds} (T_{skier\ 2} + V_{bungees} + V_{net} + U_{poles-detachable})$$

$$F = k_n s + k_b s + \mu_p N$$

The modified B-net 3 active elements, as opposed to the two of standard B-net; the elastic zones, the elasticity of the net itself, and the work to separate the poles. This is expressed graphically below.

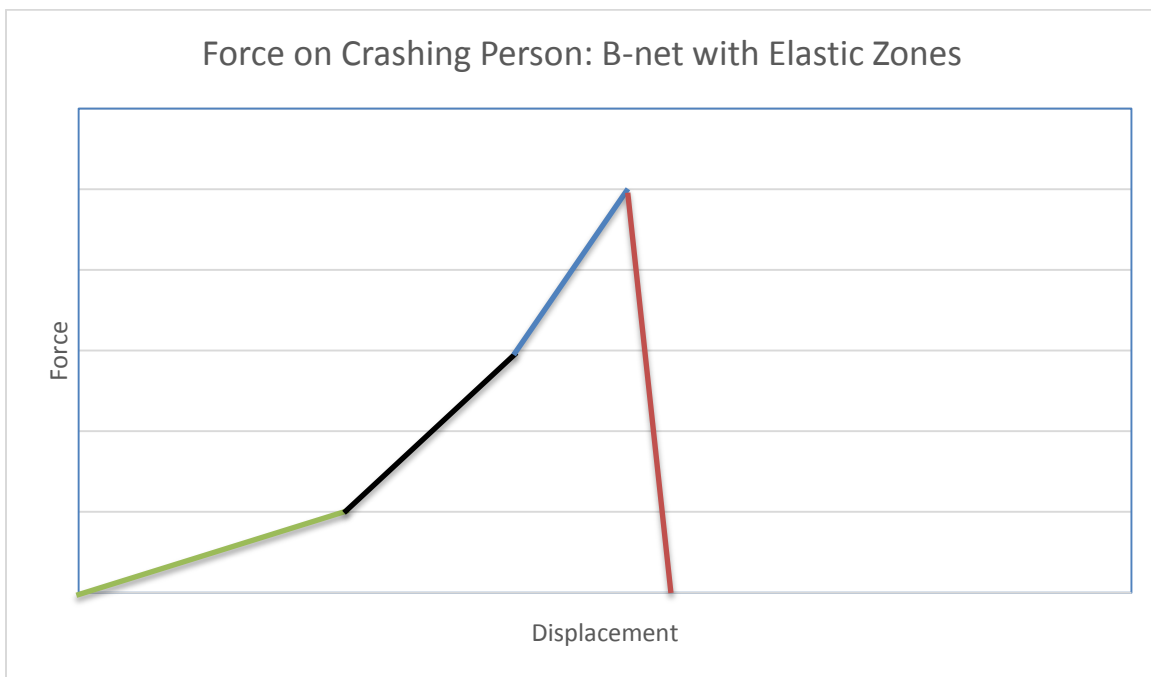

Figure 10: Crash Forces on Modified B-net

5. Preliminary Testing

We conducted a preliminary test as a proof of concept of how the elastic zones of the modified B-net perform, relative to standard B-net. As this is a design project, formal testing was outside its scope. These trials are intended as a preliminary framework, and not a valid experiment.

5.1. Methods

To compare the current generation of B-net with our improved B-net, we set up a preliminary impact test using a swing set as a pendulum. We conducted three tests, as pictured below. We attached the net to the two ends of the swing set with zip-ties. The swing set was approximately two meters long, the same as the distance between B-net poles.



Figure 11: Test 1, a tightly hung net similar to how the current generation of B-nets is set-up



Figure 12: Test 2, a loosely hung net with about 0.25 meters of slack



Figure 13: Test 3, modified B-net with the elastic zone

We used a 25 kg sand bag attached to the swing to load the nets. For consistency, the sand bag was released at a visually determined angle for three to four trials. We used a video camera recording at 120 frames per second attached to the side of the swing set for a consistent view on the impact. The high speed video was used to capture and compare the maximum net displacement on the tight B-net net, loose B-net net, and modified B-net. We also measured the average impact duration of each set of tests, by counting the frames for which the sand bag was in contact with the net.

5.2. Testing

5.2.1. Tightly Hung B-net

There was a comparatively low net stretch when the sand bag hit the tightly hung net. This led to a short impact duration of about 0.9 seconds. The low net stretch and short impact duration caused the sand bag to have a more violent crash into the net.



Figure 14: Maximum net stretch when hung tightly

5.2.2. Loosely Hung B-net

With a loosely hung B-net net there was a greater net stretch than that of a tightly hung net. The loose net allowed for more displacement, which translated to a greater duration of impact than when it was tight. With more give on the net, the sand bag was in contact for an average of about 1.1 seconds.



Figure 15: Maximum net stretch when hung loosely

5.2.3. Modified B-net

The modified B-net had the greatest net stretch compared to the other tests. From the high speed video, it could be seen that the sand bag was in contact with the net significantly longer than both the tight and loose net. The sand bag stayed in contact for an average 1.6 seconds across all tests. This softer impact is due to the elastic zone.



Figure 16: Maximum net stretch with modified B-net

5.2.4. Preliminary Test Conclusions

There were perceptible differences between the three tests. The impact duration with our modified B-net averaged a half second longer than when the net was hung tightly or loosely. From these preliminary tests it appears that our modified B-net results in lower acceleration and jerk during impacts than the current generation of B-net when hung tightly or loosely. The low net stretch and short impact duration of the first two tests represent a higher risk of injury, only taking into account the net itself. This fits with the expected results of our computations. Our modified net also noticeably created a pocket when impacted, making it more likely to catch a crashing person.

6. Discussion

6.1. Accomplishments

The modified B-net reliably prevents individuals from going off course. This reduces the risk of serious injury from collision with foreign objects. These direct impacts are more dangerous than typical crashes, as they involve higher forces and accelerations than those caused by sliding on the snow.

The current generation of B-nets could be improved, because they normally require multiple layers and can bend over when hit. Our modified B-net design has a single layer and poles to detach at a set force so that all the elements in the net are in full use in a crash.

The modified barrier is better able to limit the acceleration in a crash than standard B-net. Incorporating elastic zones into the net, makes crashes less violent by lowering the initial rate of loading. These elastic zones can also be calibrated by adjusting the amount and placement of elastic material.

We also established the need for improved B-net poles. During crashes B-net poles tend to bend down, letting people roll over the barrier. To prevent from this from happening, we propose a design for a detachment mechanism. Separating from its base during an impact would prevent the moment about the base of the pole from bending it over.

The barrier we designed has a shorter set-up and take-down time relative to normal B-net. The netting is mounted on a reel, allowing it to be set up quickly, and rolled up when finished. Using a drill or handle to roll the net up is also an improvement over doing it unassisted. It also uses a single layer, so less time needs to be spent placing poles and hanging net.

To prove the principle of elastic zones reducing impact forces, we performed an analysis of the energy involved. Our preliminary test results provided evidence supporting this analysis. The results showed the modified barrier to have greater displacement under load, and greater impact duration. This fits with the theoretical differences in barriers based on the addition of elastic zones.

6.2. Critical Assessment of the Design

Despite the improvements in our design, there are still weaknesses present. During set up, each of the detachable poles will require a hole to be drilled in the snow, which is difficult and time consuming. Our modified B-net would require a team of at least three people to put up the

net in a timely matter. Additionally, there is a possibility for the net to become tangled in its reel, especially with the addition of elastic zones.

6.3. Constraints

The Barrier should perform consistently regardless of snow conditions, because of detachable poles. The barrier can be set up to compensate for terrain features in the same way as standard B-net. By using elastic zones the modified B-net should perform reliably over the product life; it does not use any sacrificial parts. This is important in the event that multiple impacts occur over a short period of time. The barrier also complies with current standards by using high visibility netting and poles. Lastly, the barrier does not normally introduce additional source of danger.

6.4. Impact

If widely implemented, the modified B-net barrier could decrease injuries and deaths in snow sports, particularly those in racing. There is a common perception that skiing and snowboarding are particularly dangerous sports, despite evidence to the contrary. Regardless of the accuracy of the belief, improved barriers could help alleviate fears, and open snow-sports to more people.

6.5. Improvement Over B-net

The current generation of B-net should be set up with multiple layers to protect crashing people effectively. An advantage of our modified B-net is that only a single layer would be required. This saves consumers money because less B-net would be needed. It also decreases the time spent to set-up before a race. The extra time could be used to set-up barriers on other areas of the course, where there is not normally time. This also gives more flexibility on course design, as larger areas can be protected.

More predictable and consistent deceleration of a person crashing into the net would also be an advantage over the current generation. It could allow for more formal rules on the distances between barriers and the edge of the course. It could also allow for a greater degree of certainty on the safe speed of a given course.

6.6. Commercial Viability

The implementation of the modified B-net does not call for a drastic transitional cost. Ski resorts and race clubs can continue to use the materials that they already have in their inventories. The new elements of the modified barrier can be treated and sold as an upgrade

package. Elastic zones and detachable poles should initially be manufactured so that customers can easily add them to existing B-nets. As the modified barrier becomes more accepted, it could be distributed as a new package.

As ski and snowboard technology evolves snow sports will increase in speed, and the current generation of B-nets will not be able to withstand crashes. With current B-nets, many more layers would be required to slow down a crashing person. The elastic zones and detachable poles could be adjusted when needed as crashes become more severe. It is important to adopt safer barriers as speeds in snow sports increase.

6.7. Critical Assessment of Design Method

As with all design projects, this project relied on an iterative process. The first step of this process, according to axiomatic design, was to perform a decomposition identifying functional requirements and design parameters based on customer needs. During the first several months of this project, our perceptions of customer needs changed multiple times. The first major change involved the area the barrier should cover. The other was over whether the recovery system should activate automatically after impacts. Both of these resulted in top down changes to the decomposition. This ultimately resulted in a better design than we would have produced otherwise, but meant that a large amount of time was sent in the planning phase.

6.8. Future Work

We used bungee cords as the active element in the elastic zones, but for a production model of the barrier there are materials that could perform better. We did not engage in testing of these to find the best solution, but have a short-list based on known properties. The ideal material for elastic zones should have a low stiffness, high yield strength, and be easy to attach to a polyethylene net.

Elastic net is a valid candidate for the barrier's elastic zones. These made of thin bungee cords woven together as a net, and are commonly used as cargo nets. Elastic nets can stretch on multiple axes during an impact, allowing them to absorb high levels of energy. It would be easy to upgrade B-net by bonding the elastic zones if both were types of netting. Furthermore, modified B-net could be manufactured alternating polyethylene and elastic netting. If incorporated directly into the net, these elastic zones would also make scrunching or folding the net unnecessary. This approach also brings up the interesting possibility of using a barrier made entirely of elastic net.

Elastic mesh fabric, such as nylon or spandex, is also a viable improvement over the current elastic zones. It is strong, light-weight, and able stretch to over twice its surface area. Mesh fabric would present greater surface area than netting during an impact, decreasing contact pressure, and increasing energy absorption. Elastic mesh fabric could be added to existing B-net by sewing; it would be relatively simple to add this as the final step in B-net's manufacturing process.

We identified the need for a functional detachment mechanism for the bases of the poles, but decided to instead focus on elastic zones. We considered methods using a spring release mechanism or an interference fit at the base of the pole, but did not include this in our final design. This is a complex aspect of the barrier, and it could be valuable for a future MQP to work on it.

Further testing is required to learn exactly how well and consistently the modified net performs compared to the current generation. Our preliminary tests were meant to generally show how the elastic zones work under a small scale impact. There were some issues when we set up our test. We first built a much larger pendulum to swing the 25 kg sand bag into the net, but it broke under the stress of testing. As a result, our tests were done at a lower velocity than planned, and did not use a release mechanism for repeatability. While, we were able to see a difference in performance between a tightly hung net, loosely hung net, and our modified B-net, the tests were less repeatable than they otherwise would have been.

7. Conclusion

7.1. Accomplishments

- A design to catch crashing people using concave barrier net
- A design for a single layer barrier
- A design to limit acceleration during crashes using elastic zones
- A design to make set-up and take-down faster and easier, using a reel and recovery system
- Analysis of the energy and forces involved in collisions with B-net
- Establishment of a functional requirement for detachable poles
- Preliminary test results for modified B-net

7.2. Critical Assessments

- Lack of test data on wider range of materials for use in elastic zones
- Evolving scope of project lead to changes in functional requirements throughout
- Recovery mechanism allows reel to slip in direction perpendicular to barrier
- Elastic zones need to be designed around materials that allow for attachment to B-net
- Barrier requires multi-person team to set up

7.3. Remaining Issues

- Design for work based separation mechanism in detachable poles
- Analysis and testing of elastic zone materials
- Design and implementation plan for elastic zone upgrade package
- Barrier prototype
- Complete barrier testing

8. References

- Anghileri, M., Eralti, D., Milanese, A., Prato, A., Castelletti, L., & Giorla, M. (2014). Nonlinear finite element analysis applied to the development of alpine ski safety net. *International Journal of Crashworthiness*, 19(2).
- Bullas, J. C. (2005). Accident analysis and prevention 37 (2005). *Accident Analysis & Prevention*, 37(5), 972.
- Crawford, H. (2003). *Survivable Impact Forces on Human Body Constrained by Full Body Harness*. Glasgow: Health and Safety Executive.
- Estivalet, M., & Brisson, P. C. (2008). *The engineering of sport 7*. Paris: Springer.
- Giamperio, Berutti. 'Protection Barrier For Ski Tracks'. 2004: n. pag. Print.
- Gourinat, Y., & Lapoujade, V. (2008). A Dynamic Modelling of Safety Nets. *Multidiscipline Modeling in Materials and Structures*, 207-226.
- NSAA Fact Sheet. (2012, October 1). *National Ski Area Association*. Retrieved September 30, 2014, <http://www.cdc.gov/injury/wisqars/leadingcauses.html>
- Petrone, N., Ceolin, F., & Morandin, T. (2010). Full scale impact testing of ski safety barriers using an instrumented anthropomorphic dummy. *Procedia Engineering*, 2(2), 2593-2598.
- Petrone, N., Tamburlin, L., Panizzolo, F., & Atzori, B. (n.d.). Development of an instrumented anthropomorphic dummy for the study of impacts and falls in skiing. *Procedia Engineering*, 2587-2592.
- Shanahan, Denis F., (2004). *Human Tolerance and Crash Survivability*. NATO.
- Snyder, R., "Human Impact Tolerance - American Viewpoint," SAE Technical Paper 700398, 1970, doi:10.4271/700398.
- Suh, N. (1990) *The principles of design*. New York: Oxford University Press.

9. Appendices:

Appendix A: Crash Survivability Figures

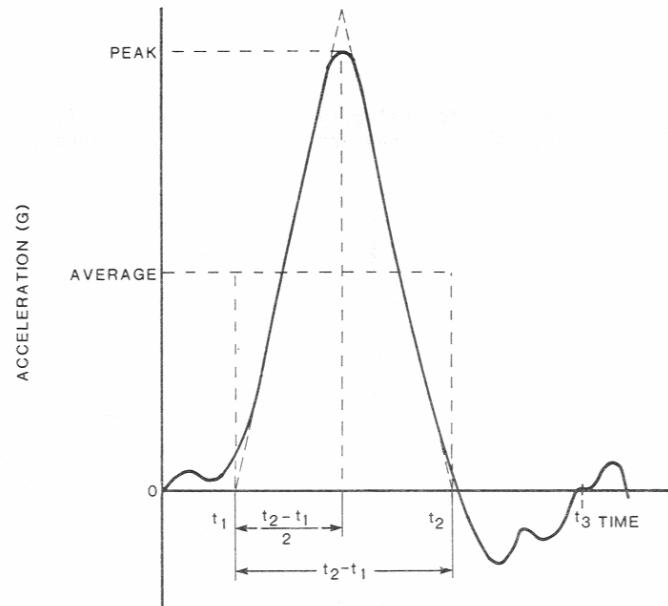

Figure 17: Acceleration vs Time (Shanahan, 2004)

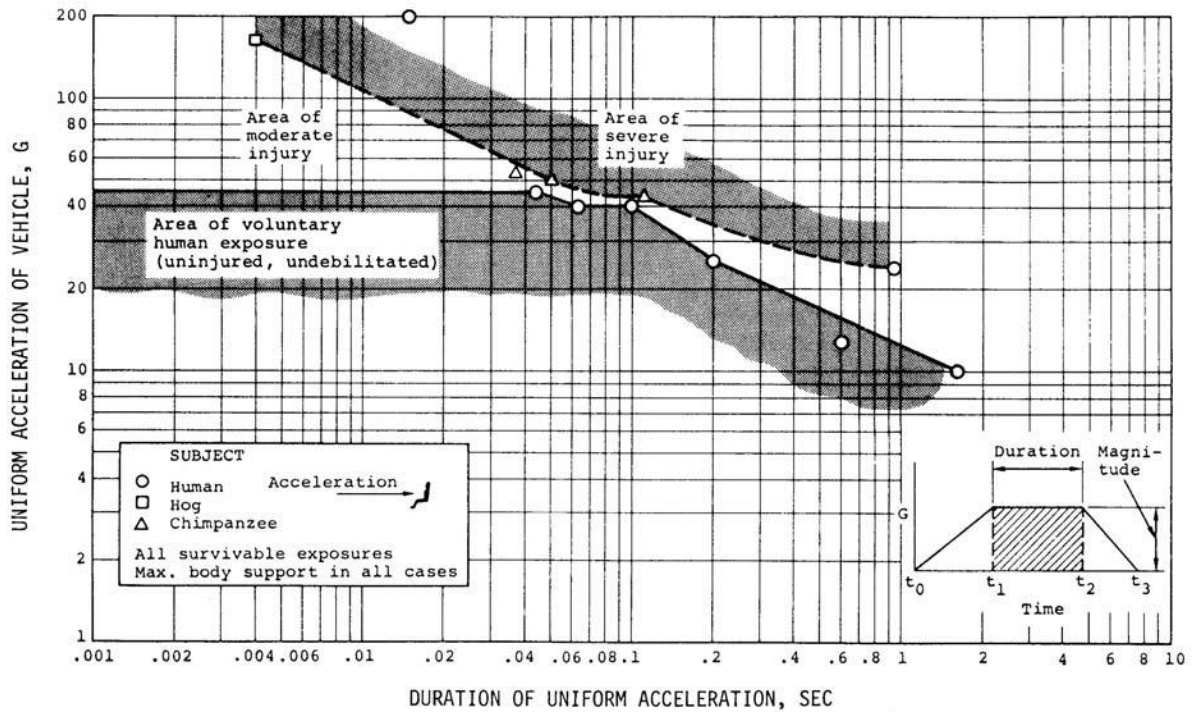

Figure 18: Acceleration Injury Criteria (Shanahan, 2004)

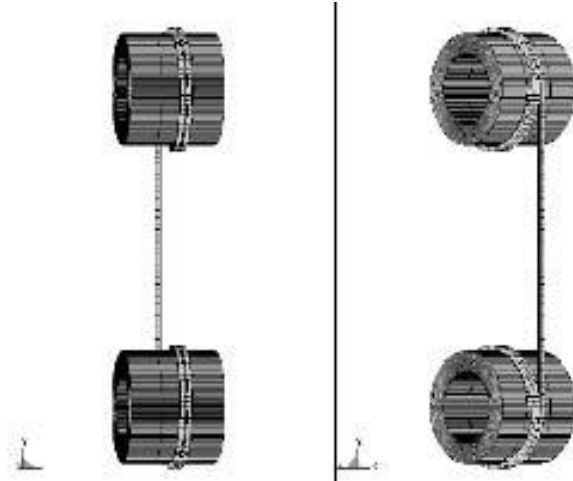

Figure 19: Finite Element Analysis (Gourniat, 2008)

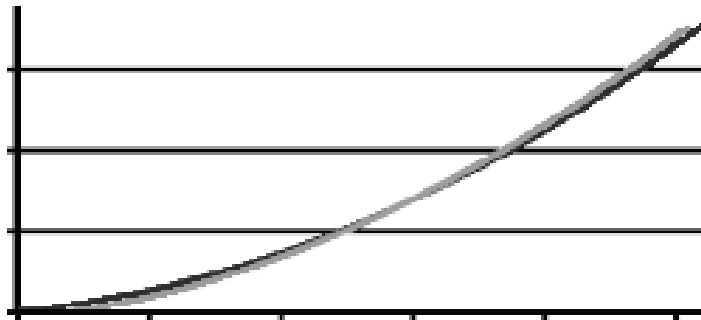

Figure 20: Strain Energy vs Tensile Elongation (Gourniat, 2008)

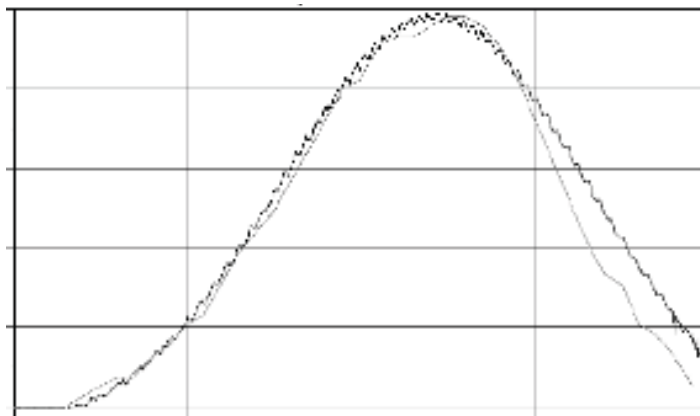

Figure 21: Impact Acceleration vs Time (Gourniat, 2008)

Appendix B: Protection Barrier for Ski Tracks

EP 1 438 995 A1

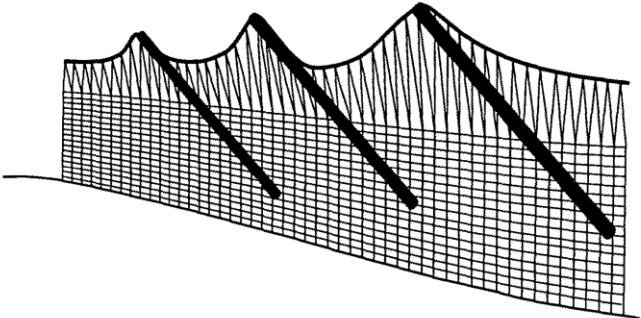

Fig. 1

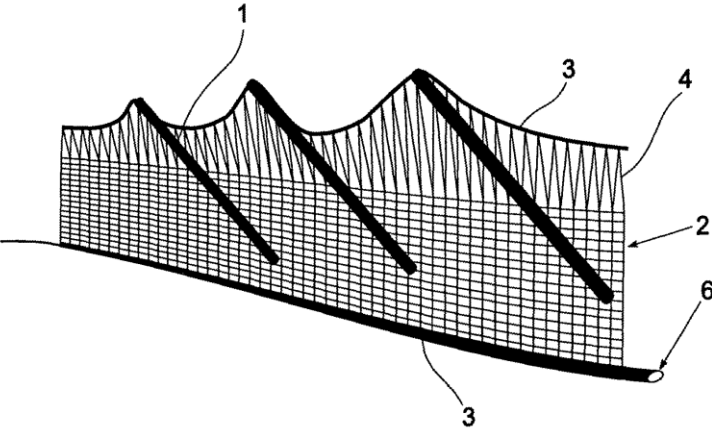

Fig. 2

Figure 22: European Patent 1 438 995 A1

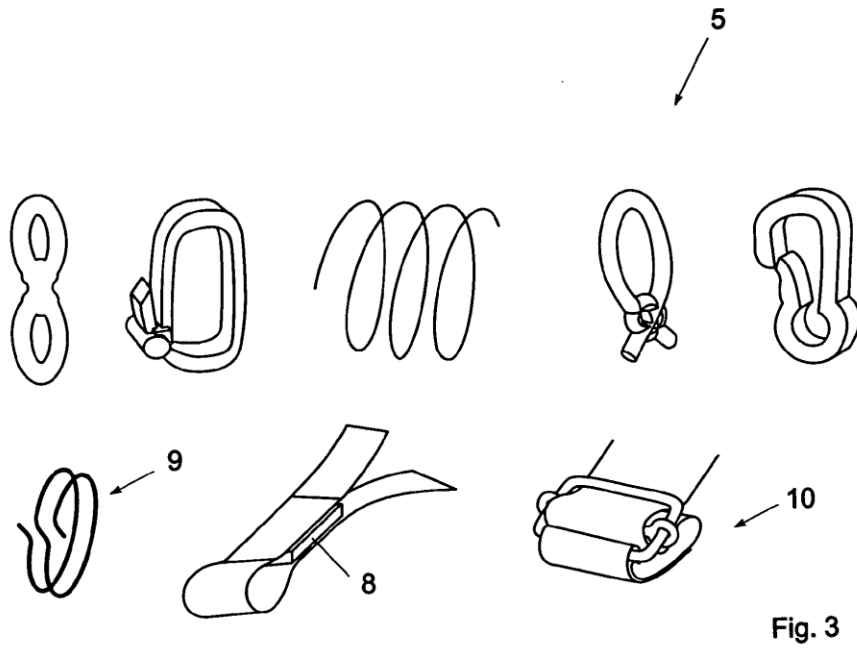

Fig. 3

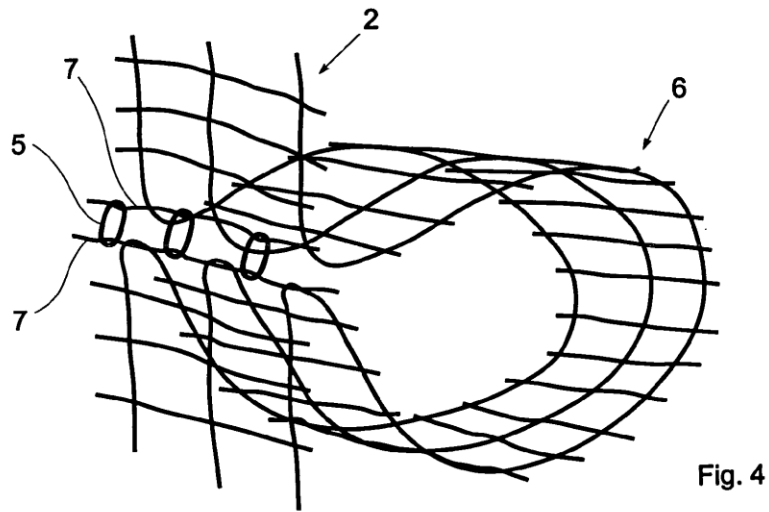

Fig. 4

Figure 23: European Patent 1 438 995 A1

Appendix C: Full Acclaro Decomposition

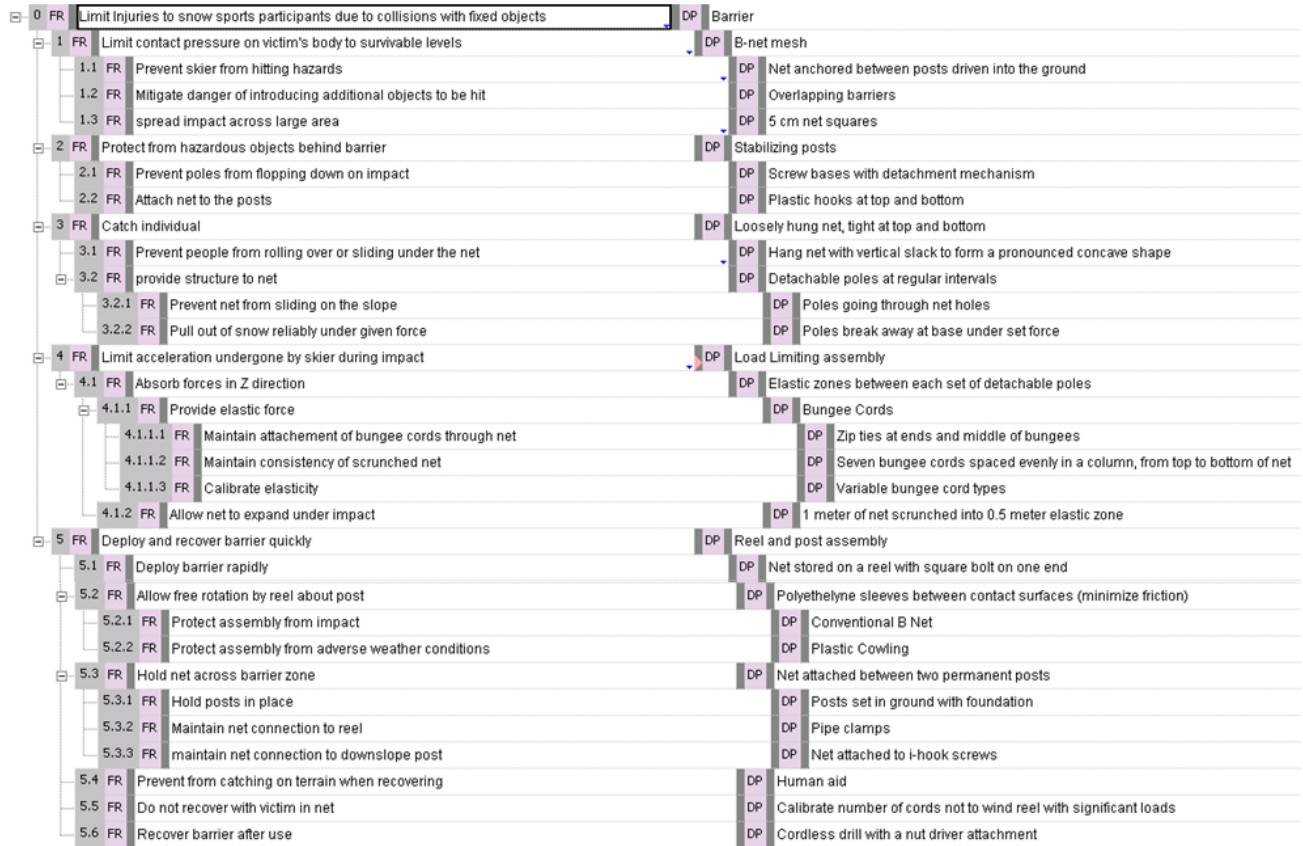

Figure 24: Full Energy Absorbing Barrier Decomposition