

April 2016

Iterative Design of Aquaponics at the American Farm School

Huilin Yang

Worcester Polytechnic Institute

Jonathan Morgan Van Blarcum

Worcester Polytechnic Institute

Mariana Harley Cabada

Worcester Polytechnic Institute

Nicholas James Venditto

Worcester Polytechnic Institute

Follow this and additional works at: <https://digitalcommons.wpi.edu/iqp-all>

Repository Citation

Yang, H., Van Blarcum, J. M., Harley Cabada, M., & Venditto, N. J. (2016). *Iterative Design of Aquaponics at the American Farm School*. Retrieved from <https://digitalcommons.wpi.edu/iqp-all/148>

This Unrestricted is brought to you for free and open access by the Interactive Qualifying Projects at Digital WPI. It has been accepted for inclusion in Interactive Qualifying Projects (All Years) by an authorized administrator of Digital WPI. For more information, please contact digitalwpi@wpi.edu.

Iterative Design of Aquaponics at the American Farm School



WPI

Huilin Yang, Mariana Harley, Nicholas Venditto, Jon Van Blarcum



Authorship

Introduction:

*Written by Huilin, Mariana, Nicholas, Jon

Background :

*Food insecurity: Written by Huilin, edited by Nicholas, Mariana and Jon

*Aquaponics: Written by Nicholas, edited by Mariana and Jon

*Education: Witten by Mariana, edited by Huilin, Nicholas and Jon

*American Farm School initiative: Written Jon edited, by Nicholas, Mariana, Huilin

Methodology:

Edit by all

*Objective 1: Witten by Mariana and Huilin

*Objective 2: Written by Jon

*Objective 3: Written by Nicholas

Design:

*Educational model: Written by Huilin edited by Nicholas, Mariana and Jon

*Research Model: Written by Nicholas edited Mariana and Jon

*Iterative design process: Written by Jon edited by Nicholas, Mariana and Huilin

*Future Implementation: Witten by Mariana edited by Nicholas, Jon and Huilin

Design document :

Formatting made by Huilin and Jon edited by Mariana and Nicholas

This report represents the work of WPI undergraduate students submitted to the faculty as evidence of completion of a degree requirement. WPI routinely publishes these reports on its website without editorial or peer review. For more information about the projects program at WPI, please see

<http://www.wpi.edu/academics/ugradstudies/project-learning.html>

Acknowledgements

For their tireless efforts helping to make this project a success we would like to thank

Nicola Bulled, WPI Project Advisor

Robert Hersh, WPI Project Advisor

Antonis Petras, Project Sponsor

Nikolas Nikolaidis, Project Sponsor

Georgia Theodoridou, Project Sponsor

And the entire AFS community for welcoming us to your school. It has been a pleasure meeting and working with all of you.

TABLE OF CONTENTS

1

Introduction 1



2



Background 6

Food Insecurity in Greece	7
Aquaponics	12
Aquaponics in Education	19

3

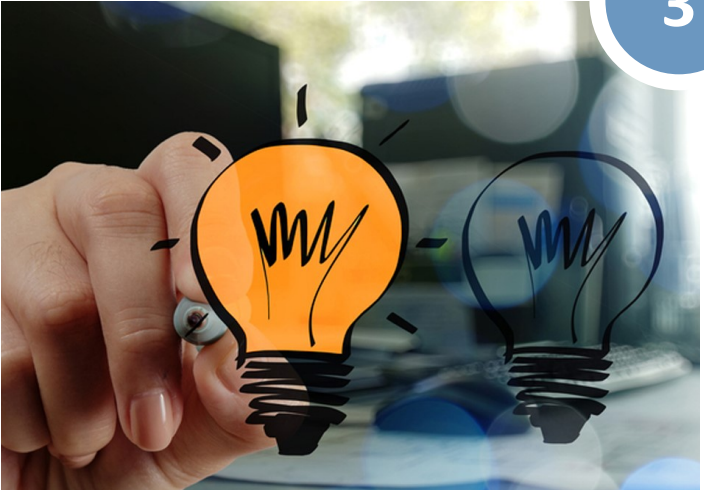

Mission 25

Approach 27

Social investigation	29
Design	35
Vetting and redesign	36

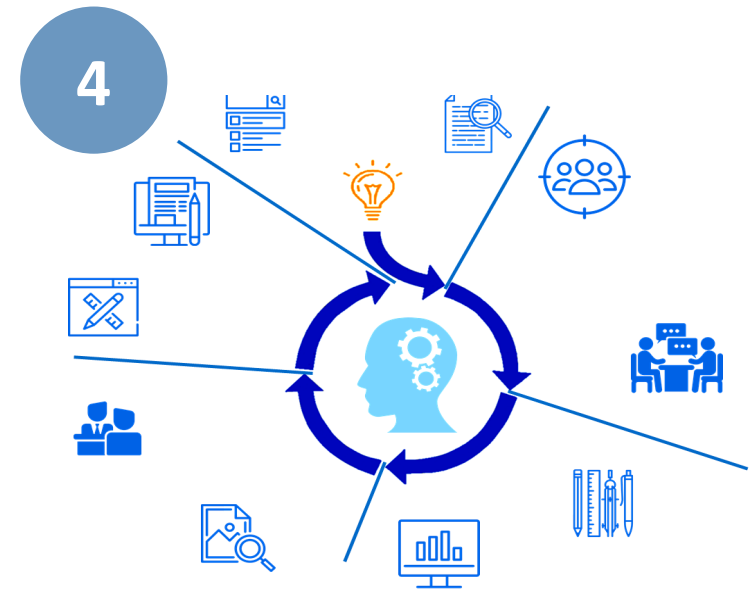

Iterative Design Process 37

Educational model	46
Research model	55
System maintenance	67

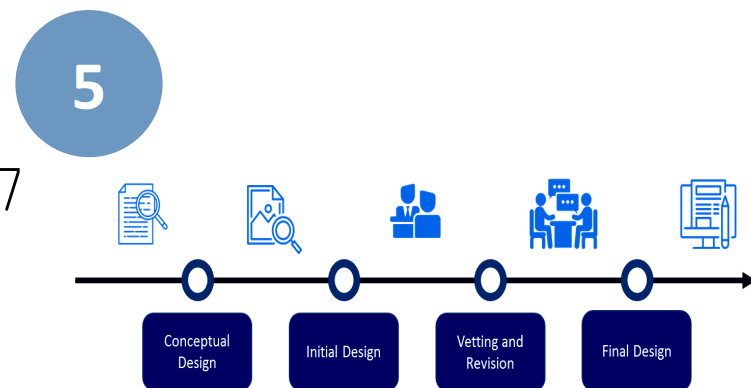

6



Future

Implementation 69

Work Cited 73

Appendix 77



Abstract

Aquaponics is an innovative, and widely investigated, urban agriculture technology that employs a symbiotic relationship between fish and plants to increase food production. The American Farm School, located in Thessaloniki Greece, is interested in investigating the potential of aquaponics. This project aimed to investigate the possibilities of integrating aquaponics within the school's educational and research curricula. Utilizing a human centered design type approach, the interests of different stakeholders were examined to guide design criteria for aquaponics systems that met the needs of the American Farm School and Perrotis College.



Water barrels covered
Make sure before leaving gate is locked

Take out your trash!
Remember: making it work will enhance

Please keep your Box/Lot

Children should not be left
unattended in the garden

This Area Is To Be WEEDED
BY ALL GARDENERS

Introduction

With rising food insecurity there is a need to develop innovative farming methods to supplement current food production techniques. Despite years of agricultural innovation and development, 1 in 9 people suffer from chronic hunger (World Food Program, 2016). In urban food deserts, economic restraints and a disconnect from food production leave people with limited access to fresh fruits and vegetables (Weatherspoon et al., 2015). Not only the global food system unable to reliably provide the world's population with food, but has led to environmental degradation. For instance, industrial agriculture is responsible for 80% of tropical deforestation and uses 70% of the world's freshwater ("5 Ways Factory Farming is Killing the Environment," 2016; "Intensive Farming," 2016). One way to address these concerns is to incorporate sustainable farming into urban communities.



Aquaponics is one environmentally friendly technique to supplement food availability in an urban environment. Aquaponics systems cultivate both fish and plants in a closed sustainable environment. By recirculating both water and nutrients, this system drastically reduces the demand for both (Blidariu & Grozea, 2011). Unlike soil-based agriculture, which requires excessive amounts of land, aquaponics can produce high yields in confined urban environments. Integrating food production techniques, such as aquaponics, into urban life reduces the distance between food and consumer, mitigating food insecurity (Goddek et al., 2015).

While there are benefits to aquaponics, the system can be hard to implement. Users must be knowledgeable in many disciplines such as chemistry, biology, and sustainability (Hart, 2013). Aquaponics systems are also difficult and costly to maintain. The system is delicate and if factors such as pH and ammonia levels are not carefully monitored the system can fail (Goddek et al., 2015). Furthermore, because aquaponics is an alternative growing technique and unfamiliar to most consumers, there are significant social hurdles to overcome to make aquaponics a consumer accepted food production technique (Specht et al., 2016).



Organized educational programs on the technology are needed to help make aquaponics a more publicly accepted urban agricultural method

(Hart, 2013)

Currently, most information and testing on aquaponics is provided by hobbyists (Hart, 2014). In order to advance the current state of aquaponics knowledge, additional research on the topic is needed. In addition, organized educational programs on the technology are needed to help make aquaponics a more publicly accepted urban agricultural method (Hart, 2013).

Presently, only a few higher educational institutions have incorporated aquaponics systems into their curriculums. These include the University of Virgin Islands, University of Massachusetts, Johns Hopkins, and Allegheny College. These institutions use aquaponics to teach students how to use the system as well as to reinforce lessons in STEM and environmental sustainability (Eatmon, 2015; Allegheny Aquaponics, 2016). Academics are gaining interest in introducing students to aquaponics and using the system in STEM curriculums (Parr, 2007).





The American Farm School (AFS) in Thessaloniki, Greece, has become an agricultural school, well known for practical education techniques. The mission is to educate students in agricultural practices and the associated sciences to promote innovative agriculture in the Balkan region (American Farm School, 2016). The school is seeking to integrate an aquaponics system into its curriculum to encourage hands-on learning and its existing innovative food growing technology research.

This project identified the different needs and requirements for an aquaponics system to be at AFS and Perrotis College through interviews with potential users, teachers, students, and administration. This information was used to identify, relevant design parameters. A design for an educationally appropriate aquaponics system was developed and vetted by the AFS community resulting in a final design. This report outlines the design process and provides recommendations for modifications and adaptations to accommodate future needs.



**AMERICAN
FARM SCHOOL**
Thessaloniki · Greece



Background

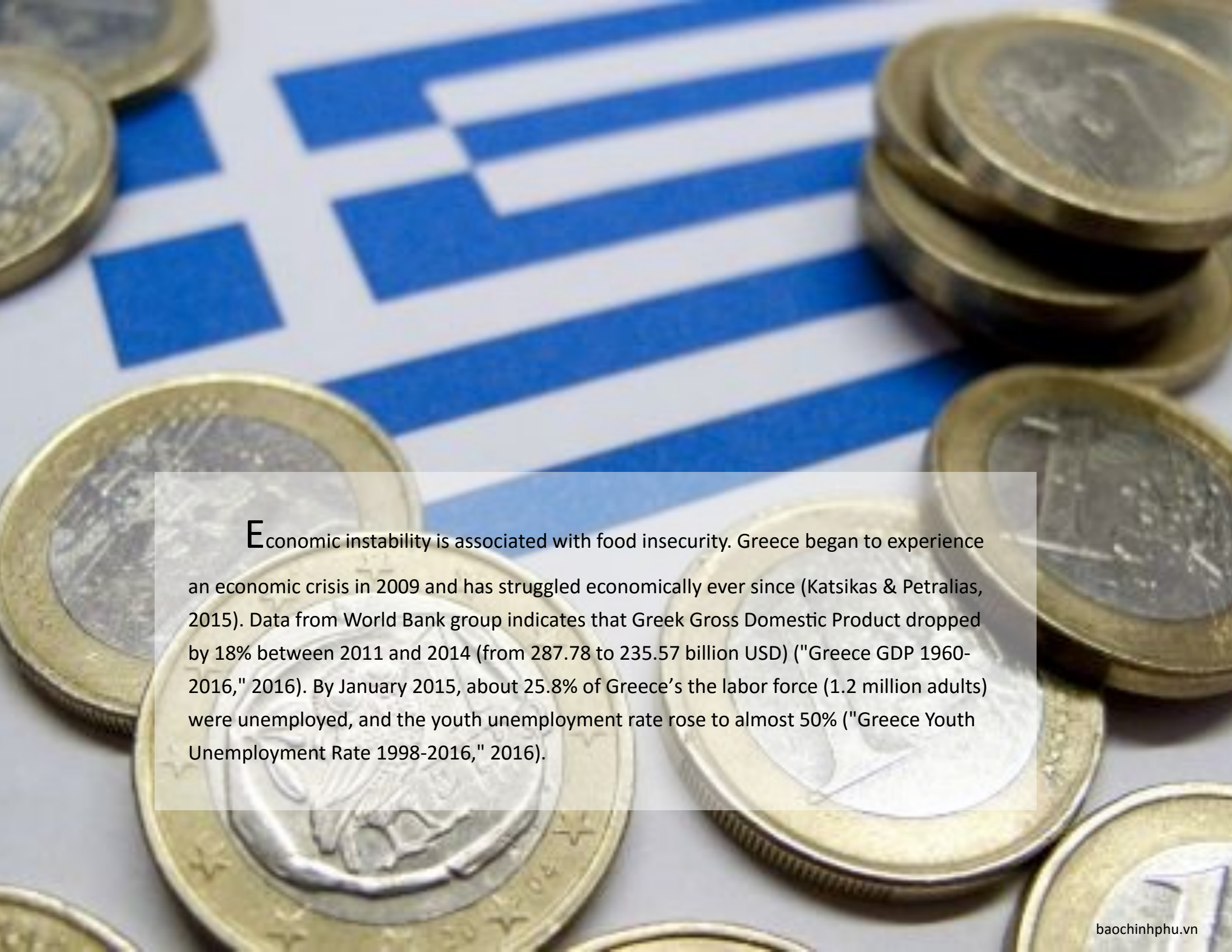

Economic instability is associated with food insecurity. Greece began to experience an economic crisis in 2009 and has struggled economically ever since (Katsikas & Petralias, 2015). Data from World Bank group indicates that Greek Gross Domestic Product dropped by 18% between 2011 and 2014 (from 287.78 to 235.57 billion USD) ("Greece GDP 1960-2016," 2016). By January 2015, about 25.8% of Greece's the labor force (1.2 million adults) were unemployed, and the youth unemployment rate rose to almost 50% ("Greece Youth Unemployment Rate 1998-2016," 2016).

Rising poverty is a major problem occurring because of the economic crisis in Greece. According to recent data from Eurostat, more than one third of Greek citizens are considered at risk of poverty (@EconDailyCharts, 2015). Beginning in 2011, the risk of poverty in Greece increased, and is currently 7% higher than the EU average (Katsikas & Petralias, 2015). Both mean and median net income of Greeks decreased approximately 30% from 2010 to 2013. A 2015 study conducted by the Economist shows the severity of the economic crisis in Greece. This study compared the

overall economic performance of Greece to the European Union averages. In terms of percentage of population at risk of poverty, Greece increased from 28% to 35% between 2008 and 2014. While the rest of the EU had an average of only 22% in 2014. In addition, the Gross debt of Greece's national government has increased from 100% of GDP to about 175%. This is significantly higher than the 2014 EU averages of about 95%. Additional data collected by this study, including unmet medical needs due to cost, is shown in the graphs in Figure 1 (@EconDailyCharts, 2015).

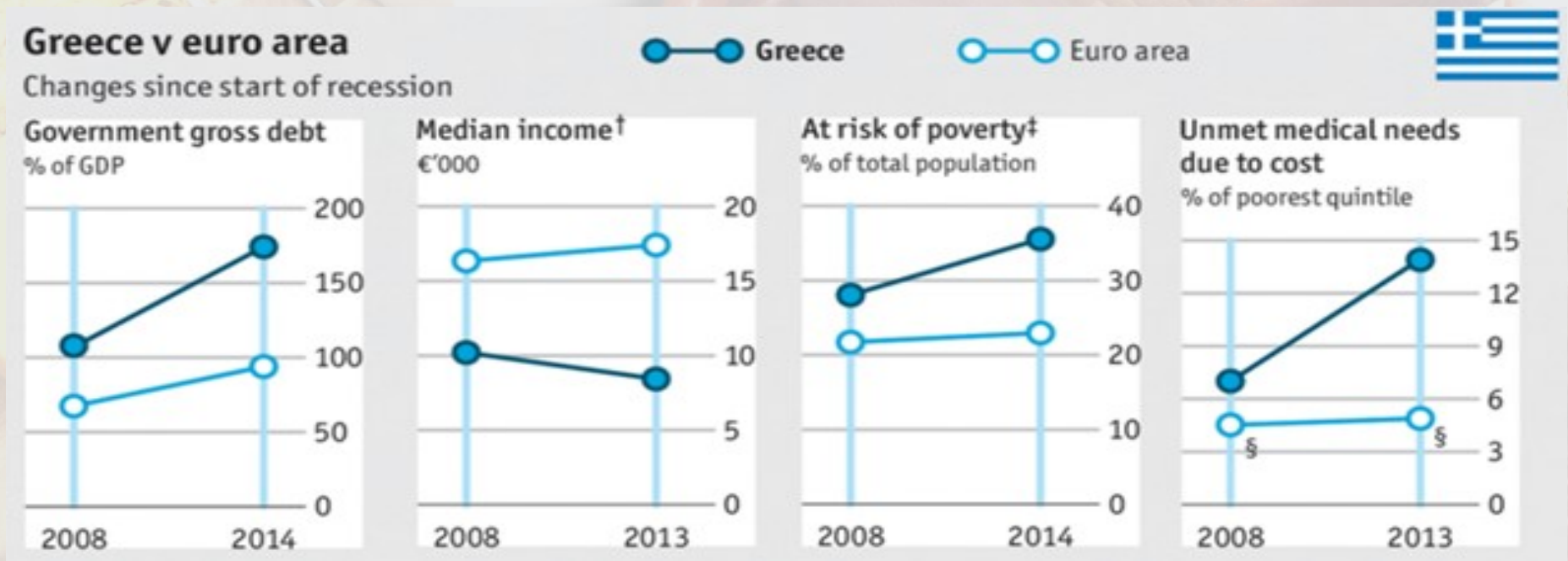

Figure 1: Comparison of Greece and EU in terms of government gross debt, median income, at risk of poverty and unmet medical needs (@EconDailyCharts, 2015)

During the economic crisis in Greece, food prices began to increase contributing to food insecurity in the country. At the end of 2015, Greece had the highest increase in food prices within the European Union. Price increases ranged from 0.3% for cheese to 17.2% for fruit. Based on data from Eurostat, the price of bread and wheat increased 4.6% while prices in the rest of the EU dropped 5% ("Record hike in Greek food prices," 2016). Compared with the food prices in supermarkets in 2014, the prices had increased an average of 4.2% by August 2015 (Chrysopoulos, 2015).

Both poverty and increases in food prices have contributed to food insecurity in Greece. According to the Life Sciences Research Office, food insecurity is defined as, "The ability to acquire acceptable foods in socially acceptable ways is limited or uncertain" (Wunderlich, 2006). The number of families in Greece unable to afford meals with meat every other day increased from 7.1% in 2008 to 14.1% in 2012 (Katsikas & Petralias, 2015). One consequence of increased food insecurity, is greater reliance on soup kitchens (Hartocollis, 2015; Katsikas & Petralias, 2015). According to a 2015 New York Times report on the impact of the Greek financial crisis in Athens a local soup kitchen now serves 600 to 1000 people a day and are even forced to turn away people because of limited food supply. Demand for food is rising so rapidly that soup kitchens are concerned about having a sufficient food supply (Hartocollis, 2015).





With the rising food insecurity, there is an increasing interest in identifying more direct and less costly ways to acquire food. For instance, efforts to reduce food prices were made by establishing direct connections with farmers, allowing people to avoid the “middleman market” (@BBCWorld, 2016; Henley, 2015). Another long-term approach to improving food self-sufficiency is adapting urban agriculture practices. Urban agriculture is an implementation of agricultural practices and food production in a city environment (Rahman, 2013). As a supplement to current agricultural practices on traditional farms, urban agriculture is a possible solution for food insecurity in urban settings.





citizensforeurope.rfo20.net



citizensforeurope.rfo20.net



static01.nyt.com

As Orestes Kolokouris, assistant to the Green Member of Greek Parliament, reported, the economic crisis accelerated the development of urban agriculture in Greece. Two well-known cases of urban agriculture in Greece are the fields at Hellinikon Airport in Athens and the ex-military camps in Thessaloniki. At both sites, urban agricultural practices are providing supplemental food for their respective cities (Kolokouri, 2015). These sites reclaimed the free space within their communities and are using them for agricultural purposes. Sites like these, are the result of important social movements that work in conjunction with other urban agricultural methods. This approach not only reduces food insecurity by increasing food supplies, but also provides entrepreneurship opportunities and jobs for the residents of the cities (Redwood, 2012).



Wikimedia.org



Backyardaquaponics.com

Due to the limited space and resources in urban areas, urban agricultural practices often have restricted size, energy, and water requirements (Goddek, 2015). Aquaponics is one popular urban agricultural technique that can accommodate these requirements while producing high yields of fresh food. This system is an innovative farming method that cultivates both plants and fish in a closed and cost effective system.



Aquaponichowto.com



Jandjaquafarms.com

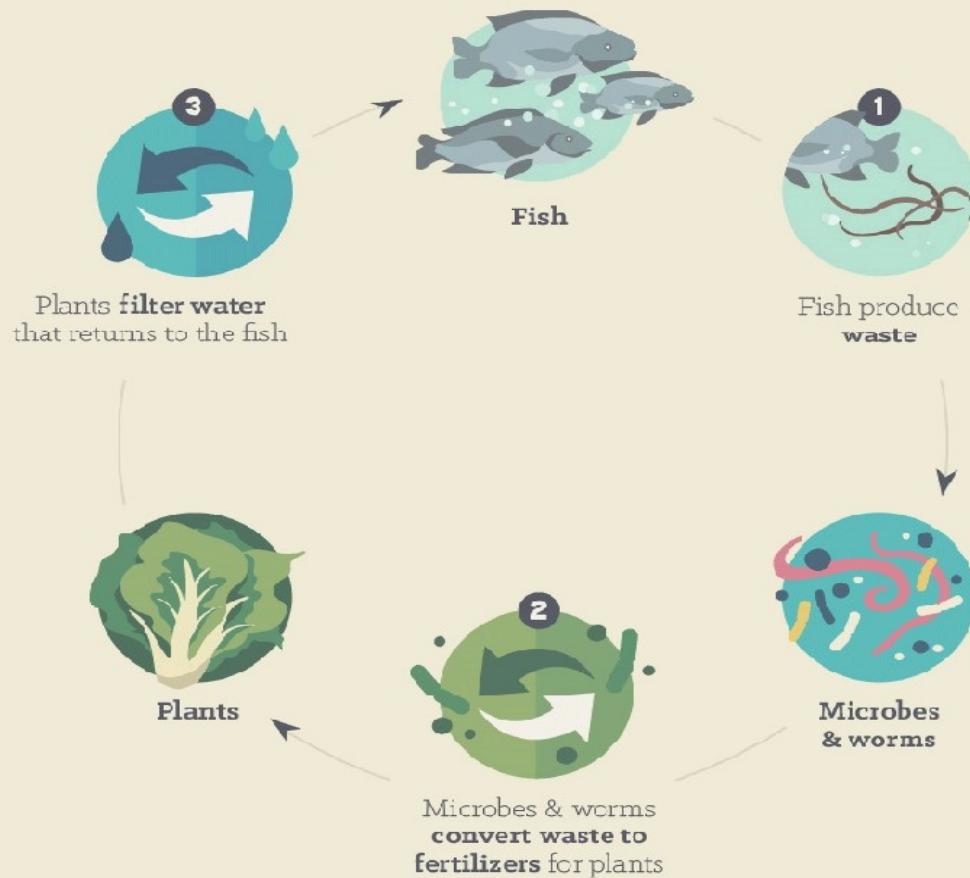

Figure 2: Plant, fish, and bacteria symbiosis forming the foundation of an aquaponics system

The system utilizes a symbiotic relationship between fish, plants, and essential bacteria to cycle water and nutrients for the sustainable cultivation of food products, see Figure 2 (Hu, Lee, Kim, Brotto, & Khanal, 2015). By circulating water between a fish tank and plant beds, the nutrients produced by the fish are transferred into the plant beds where they are converted into nitrates and other nutrients necessary for plant growth by bacteria living in the roots of the plants (Hu, Lee, Kim, Brotto, & Khanal, 2015). By absorbing the nutrient rich waste, toxic to fish in high quantities, the plants purify the water providing a healthy growing environment for the fish. The symbiotic relationship between plants and fish result in a reduced need for fertilizers and other additives while creating a suitable environment for both to grow (Hussain et al., 2014). The scale of aquaponics can vary from large, commercial facilities to small, in home systems.

The efficiency of an aquaponics system depends on the amount of nutrients in the water. A balance needs to be established between how much nutrients the fish produce, as well as how much nutrients the plants absorb. The nutrient richness of the water depends on several aspects. Fish density, fish feed, fish species, plant species, and bacteria all affect how the system operates. To make sure the system is operating to its full potential, careful monitoring of nitrogen levels, urea, pH, dissolved oxygen, as well as other nutrients is important. In addition, the growing bed mediums for the plants can be changed in order to further optimize the system. Media such as gravel, clay balls, or a floating growing bed can be used and each has different benefits (Lennard & Leonard, 2006). All of the parameters involved in the system can be modified for variation in system size and desired growth output (Hussain et al., 2014).

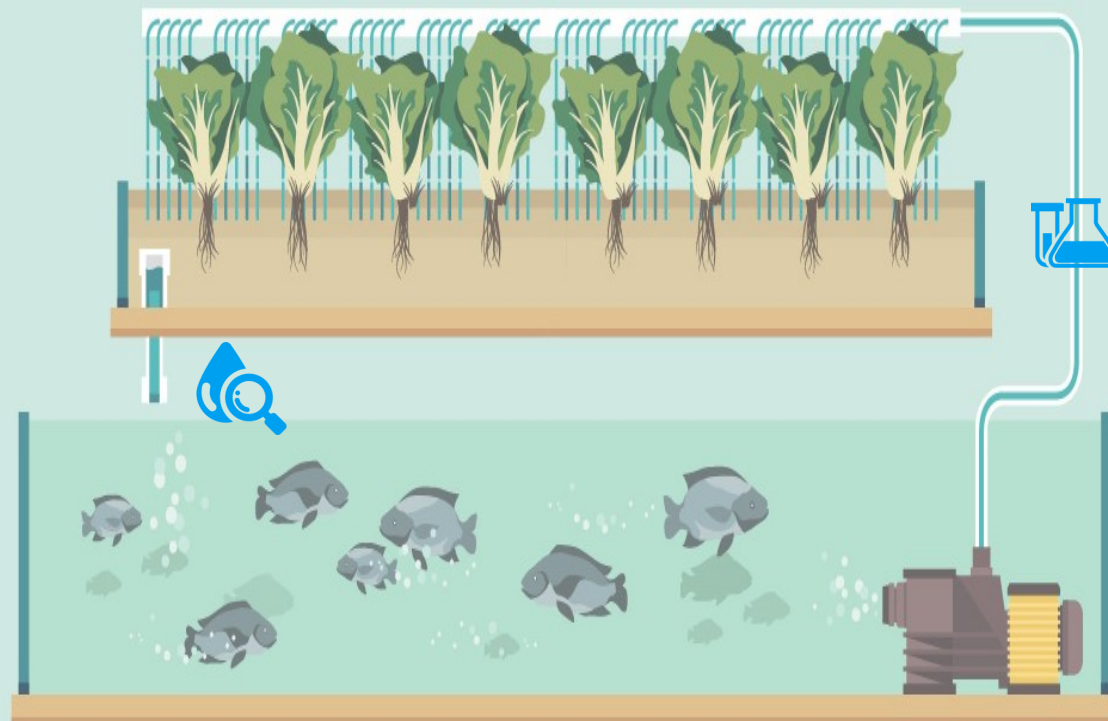

Figure 3: General aquaponics schematic



There are many benefits to utilizing an aquaponics system. When run correctly, it can function as a cheap way to produce a lot of food in a small amount of space (Tokunga et al., 2015). Fertilizer costs are minimal and the closed system drastically reduces the need for nutrient additives. Aquaponics utilizes fish feed as the nutrient source and it is recycled through the system. In addition, aquaponics systems are typically indoors and do not need to use pesticides to prevent rodents and insects from ruining the crops (Goddek et al., 2015). The reduced need for fertilizers and pesticides makes aquaponics more environmentally friendly than intensive agricultural practices that rely on high inputs. Furthermore, aquaponics recycles 98% of its water (Al-Hafedh, 2008). The yield, space, cost, and environmental benefits suggest that aquaponics systems have a lot of potential to help provide low cost food to homes in urban environments such as Thessaloniki.

However, even with the apparent benefits of aquaponics there are still social considerations that may hinder the acceptance and implementation of aquaponics systems . In particular, will consumers accept the output as a viable food source? In many countries, traditional farming methods are preferred and deviations from these methods can meet push back from the population (Specht et al., 2016). In a study of potential uses of green space in Berlin, 386 urban community members were surveyed, examining urban agricultural projects in the city (Specht et al., 2016). Aquaponics was much less preferred than methods similar to traditional farming techniques such as, roof top or community gardens. According to the study results, 65% of the Berlin residents stated that they would not like to see urban space used for an aquaponics farm. Residents also indicated that the production of livestock and fish in an urban environment is a poor and unhealthy practice.





بستان
BUSTAN
fresh·healthy·local

Mixed Baby Leaf Salad
سلطة بيبي ليف

LETTUCE
PESTICIDE FREE
AQUAPONIC GROWING

يرجى الحفظ في مكان بارد و الغسل قبل الاستخدام.
يفضل الاستخدام خلال ٧ أيام من تاريخ الإنتاج.

www.bustanaquaponics.com info@bustanaquaponics.com +2 01 020 348 899

بستان
BUSTAN
fresh·healthy·local

Mixed Baby Leaf Salad
سلطة بيبي ليف

LETTUCE
PESTICIDE FREE
AQUAPONIC GROWING

يرجى الحفظ في مكان بارد و الغسل قبل الاستخدام.
يفضل الاستخدام خلال ٧ أيام من تاريخ الإنتاج.

www.bustanaquaponics.com info@bustanaquaponics.com +2 01 020 348 899

In order for aquaponics to be viable for inner city use, the quality of the food would need to be perceived as equivalent to or surpassing that of traditional farming methods. Additional challenges in marketing of aquaponics products also needs to be addressed (Specht et al., 2016). The price of output from aquaponics systems would need to be comparable to or cheaper than existing food products to make it appealing to consumers. These indicators suggest that in order to overcome the social stigmas associated with urban aquaponics development, more people need to be informed of the potential offered by aquaponics.

Aquaponics systems are commonly viewed as a resource for food production. However, its interdisciplinary nature and the required technological skills for implementation make it an exceptional educational tool as well (Hart, 2013). There are higher education institutions that already use aquaponic systems (Eatmon, 2015). For example, Allegheny College's sustainable development class has implemented an aquaponic system to facilitate student learning and exemplify environmental sustainability. The educational values that aquaponic systems have at Allegheny include understanding the science behind the nutrient balance of the ecological system, and hands-on experience with an interdisciplinary and sustainable technology. However, when school is not in session educators and administration felt it will be a financial and time burden to maintain the system. The system positively impacts the student learning experience due to the technical challenges it presents, the emphasis on different scientific fields working together, and the conveyance of knowledge related to the proper management of natural resources (Allegheny aquaponics, 2016).





Other universities such as Johns Hopkins have integrated the system in order to experience some of the benefits mentioned above. As stated by the John Hopkins Center for a Livable Future, “Aquaponics inspires dialogue about sustainability and the food systems, making it a powerful teaching vehicle” (Ganello, 2016). Other universities such as University of Arkansas, University of Virgin Islands, and University of Massachusetts Amherst have implemented aquaponics to achieve similar goals.





Studies have been conducted to explore the benefits to students that arise from the aquaponics system. For example, Jon Schneller's (2015) case study evaluated the effects of aquaponics and hydroponics learning models on 5th and 6th grade students from two schools in New York. The study divided the thirty two students into two groups, one that utilized garden based learning and a control group that did not. Each group was issued tests before and after the study in order to assess pro-environmental behaviors. The students from both groups also took part in focus groups and interviews to see how the learning method affected their views towards the environment. The study found that students who learn with aquaponic systems are more inclined to pro-environmental behaviors.

Emily Hart (2013) from the University of Massachusetts Amherst conducted a dissertation project exploring the main reasons why educators choose to use aquaponics in their lessons. The project consisted of collecting qualitative data through phone interviews with 58 educators who currently use aquaponics in an educational setting. The purpose was to help educators manage expectations for aquaponics while establishing objectives for their particular educational settings. Along with many beneficial long-term environmental impacts the system promotes, its hands-on nature helps teach students many lessons, particularly in environmental and STEM topics, as indicated by 26% of

the educators surveyed by Hart (2013). Aquaponics based education systems can be integrated in order to demonstrate chemical, biological, and environmental concepts. Also it facilitates lessons on complex theories and technologies, so students “solidify their understanding of scientific theories” (Hart, 2013). Table 1 outlines the opinions of 58 educators who were surveyed.

As shown, the main reasons why the educators surveyed chose to use aquaponics are the hands-on learning experience it gives and its ability facilitate STEM education. These two reasons encompass 52% of the reasoning behind using aquaponics in the classroom.

Code	Frequency (# Experts)	Proportion (%)
Flexible	10	17
Food Concepts	14	24
Fun	4	7
Hands on Learning	15	26
STEM Concepts	15	26

Table 1: Reasons why educators choose aquaponics in education (Hart, 2013)

Within an aquaponics system are a number of underlying concepts essential to an agriculture curriculum. Plant and fish nutrient requirements, water quality, soil toxicity, the nitrogen cycle, and symbiotic relationships are all essential elements of aquaponics. Having an aquaponics unit in the classroom provides students with an opportunity to learn about all of this first hand. Interest in bringing this technology into the classroom is nothing new. A 2002 study conducted by Wardlow and colleagues (2002) placed a small-scale aquaponics system inside 27 schools. After using the aquaponics systems in their classes, ten teachers were surveyed to determine the usefulness of teaching using aquaponics. This study found that the teachers were excited to utilize the system and their students had a lot of interest in learning more about hydroponics and aquaculture.

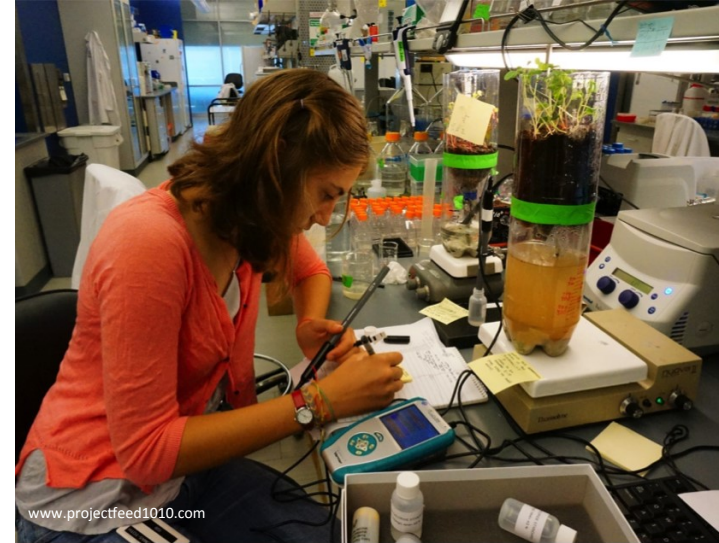

Even though aquaponics systems have many benefits, there are several challenges that prevent its implementation across educational curricula. The challenges encountered are mainly based on school infrastructure, space, and technical equipment required to implement and maintain the system (Hart, 2013). As mentioned in the description of the technical aspects of the system, there is a high degree of technical complexity involved in maintaining a successful aquaponics system. To find a suitable space that meets the temperature and energy needs of the system is a challenge for most institutions. Another challenge is maintaining the system when school is not in session. In order to operate the system during these times, additional staff time is needed for maintenance. Even though aquaponics has to overcome these challenges to be properly implemented into an educational curriculum, institutions such as the American Farm School (AFS) are exploring the possibility of integrating this innovative farming method.

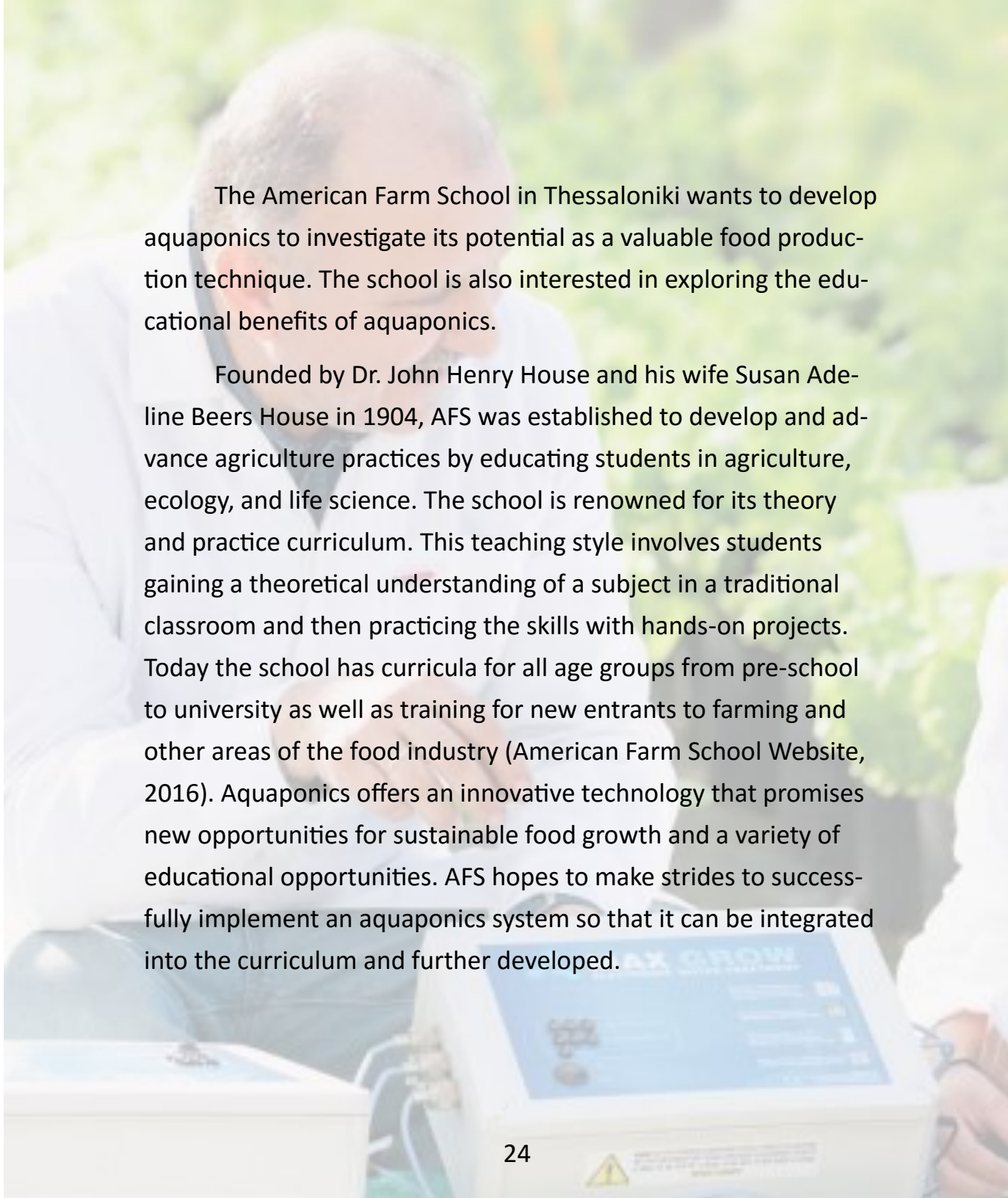

A man in a white lab coat is looking down at a piece of equipment in a greenhouse. The background is filled with green plants.

The American Farm School in Thessaloniki wants to develop aquaponics to investigate its potential as a valuable food production technique. The school is also interested in exploring the educational benefits of aquaponics.

Founded by Dr. John Henry House and his wife Susan Adeline Beers House in 1904, AFS was established to develop and advance agriculture practices by educating students in agriculture, ecology, and life science. The school is renowned for its theory and practice curriculum. This teaching style involves students gaining a theoretical understanding of a subject in a traditional classroom and then practicing the skills with hands-on projects. Today the school has curricula for all age groups from pre-school to university as well as training for new entrants to farming and other areas of the food industry (American Farm School Website, 2016). Aquaponics offers an innovative technology that promises new opportunities for sustainable food growth and a variety of educational opportunities. AFS hopes to make strides to successfully implement an aquaponics system so that it can be integrated into the curriculum and further developed.



Mission Statement

The goal of this project was to design an aquaponics system for the American Farm School and Perrotis College that will serve as an educational and research tool. This innovative growing technique will serve the purpose of facilitating scientific concepts while giving the opportunity for further research on the technology. The following three objectives structured this project to achieve this goal:

- 1) Identify stakeholder requirements for integrating aquaponics into AFS and Perrotis College educational curriculum
- 2) Develop an aquaponics system design for the American Farm School and Perrotis College using a human centered design process
- 3) Assess the different functionalities of aquaponics beyond the educational curriculum and determine recommendations about how to explore these possibilities



Approach

To produce a design of an aquaponics system that meets the needs of AFS and Perrotis College a human centered design process was used. The human centered design process consists of developing a model based on social and background research and then assessing its qualities based on user feedback (Brown, 2008). This process consisted of 5 stages, background research, social investigation, design, vetting and revisiting, and redesigning. The intensive background research was conducted through literature reviews and research assessments. By supplementing the research process with social considerations, designs are made more intelligently, accurately meeting the needs of the end users. The cyclical process of human centered design allows for a continuous vetting and refining of the design to better match the needs of the institution.

Social investigation



Different groups were identified within the AFS and Perrotis College community interested in aquaponics. Through in-depth semi-structured interviews, system requirements were gathered from these groups. The interviews were conducted with five administrators, five AFS teachers, eight Perrotis College Professors and eleven students to assess the interests and needs of these groups. Semi-structured interviews were used because it is one of the most effective ways of getting a broad range of information from limited number of interviewees (Longhurst, 2003). Interviews were conducted with each group until it became apparent that no new information was being uncovered. This was the point of saturation where it was deemed that a representative sample of each group had been interviewed (Longhurst, 2003).





The interviews provided broad information about the criteria that was taken into account to design the aquaponics system. All interviews began with a brief explanation of what an aquaponics system is and an introduction of the project's purpose. The basic concepts were explained by using previous designs of systems (Appendix 4). To ensure the interviews could be referenced, a verbal consent script was presented at the beginning of each interview (Appendix 1). The interviews were recorded for later analysis. Each interview was structured uniquely to obtain as much relevant information as possible.



The aquaponics system is intended to facilitate the educational objectives of the school, therefore it was important to consider the needs of the instructors. With aid from the high school counselor and project sponsor, a list of instructors to interview was composed (Appendix 5). These instructors were selected based on their academic roles, known interest in plant growth, alternative growing, and aquaponics. The instructors were contacted and interviews were arranged.

The intention of these interviews was to gain an understanding of how the instructors could utilize an aquaponics system, how it might fit within the school curriculum and project work at the school. Details were needed about what topics are taught in each department and how an aquaponics system could be used to enhance teaching of these topics. From these interviews, interest in aquaponics was determined and noted for the later design vetting process.

Ultimately, the aquaponics system is intended to benefit the students of AFS and Perrotis College. Eleven students were interviewed to investigate what they want to achieve and learn from hands on project work with an aquaponics system. Particular attention was given to the students past project experiences to better understand what makes the project experience beneficial so that certain elements can be included in the design of the aquaponics system.

The views of AFS and Perrotis college administrators were also crucial to understand how the aquaponics system can be successfully implemented. The administrators of the elementary school, AFS, and Perrotis College were interviewed in order to understand new project implementation approaches and the goal of their respective departments within the institution. These interviews emphasized the feasibility of building the aquaponics system. Furthermore, these interviews were used to develop a thorough understanding of the school's dynamics and how this project fits into the bigger objectives of the school.



Education

To analyze the interviews, interviewees were classified into four clusters consisting of students, Perrotis College instructors, AFS instructors, and administrators. A modified grounded theory approach was used to analyze the collected data (Charmaz and Mitchell, 2001). Using this approach, all interviews were transcribed and analyzed as they were completed. Coding was conducted in an iterative fashion to allow themes to emerge from the data. Once all the interviews had been conducted and through a round of initial assessment, a codebook was established using information for each theme. All interview transcripts were subsequently coded using the same set of themes. These interviews resulted in a set of desired design parameters. These parameters reflected the feedback given by those interviewed.

Pertaining to using the system for the education of students or for students to use as a project

Research

Pertaining to using the system as a research tool for plant/fish growth

Design

Pertaining to honing an aquaponics system for optimum design for some select purpose (food production, water treatment etc)

Social

Information pertaining to social considerations to be made with the aquaponics system

Commercial

Information important to making aquaponics profitable

Design

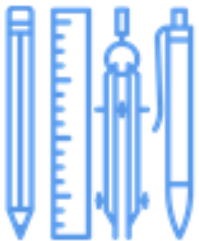

The design parameters are a comprehensive set of technical requirements for the system. These parameters were used to generate the preliminary design for the school. To model this design Google's 3D imaging software, Sketchup, was used. This software was chosen because it is an open source software that anyone working on this project in the future can use. The initial model provided as much detail as possible, with accurate tank dimensions, pump position, plant bed types, and other components.



Vetting and Redesign



To vet the preliminary design, the initial model was presented to AFS and Perrotis College community members who expressed interest in the first round of interviews. The feedback from these short, semi-structured interviews, produced a collection of critiques of the design. These critiques were used to revise the system's requirements and design parameters. Likewise, these revised design parameters were used to continuously update the designs. This cyclical revision and vetting process produced a design deemed optimal for the AFS and Perrotis College. Since there are a number of different groups within AFS and Perrotis College that intend to use the aquaponics system differently, comments and suggestions were also used to guide the development of additional design recommendations to address different opportunities for aquaponics use.



Iterative Design Process

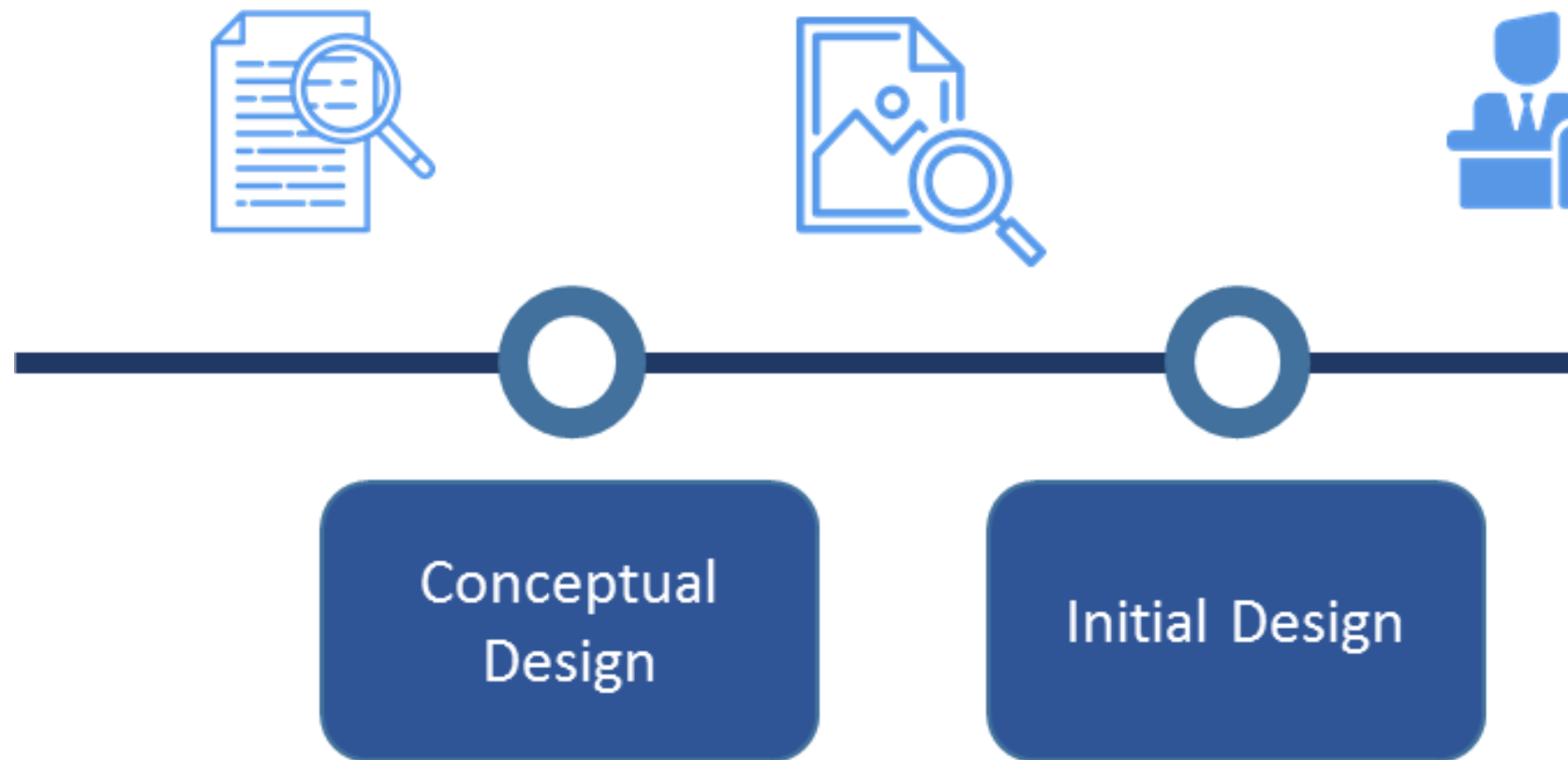



Vetting and
Revision

Final Design

The design of the aquaponics system was meant to reflect the interests of AFS and Perrotis College. To ensure the design fulfills the parameters discovered throughout the social investigation an iterative design process was used. In an iterative design process an initial design is continuously refined with feedback from community members. The starting point for this project was a simple conceptual design of aquaponics. This diagram demonstrates how aquaponics operates and offered a groundwork for the project to develop from.

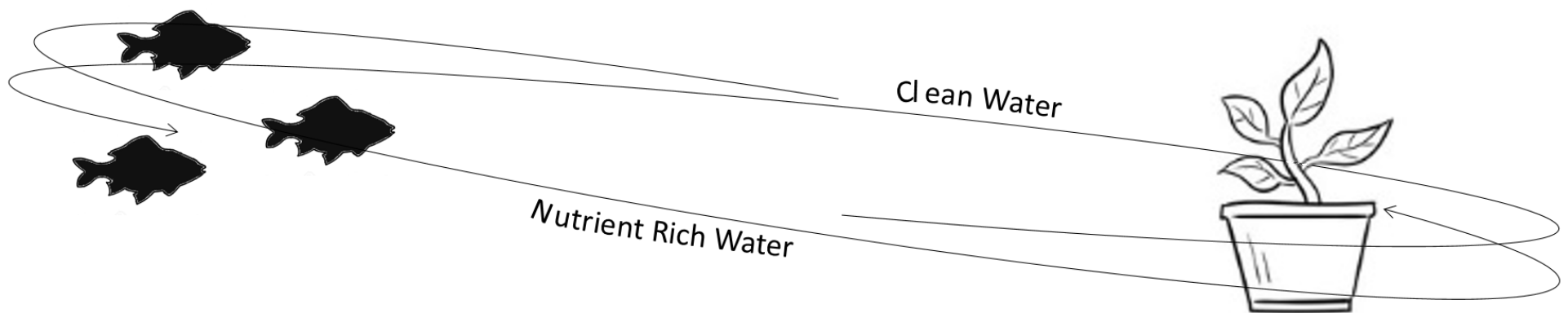

Figure 4: Conceptual aquaponics design

Early conversations with the sponsor and members of the school suggested that the school wanted something that could operate as an educational tool and a research project. Based on this preliminary discovery a rough design was generated. This design was made to encourage conversation about the educational and research functionalities needed from the design.

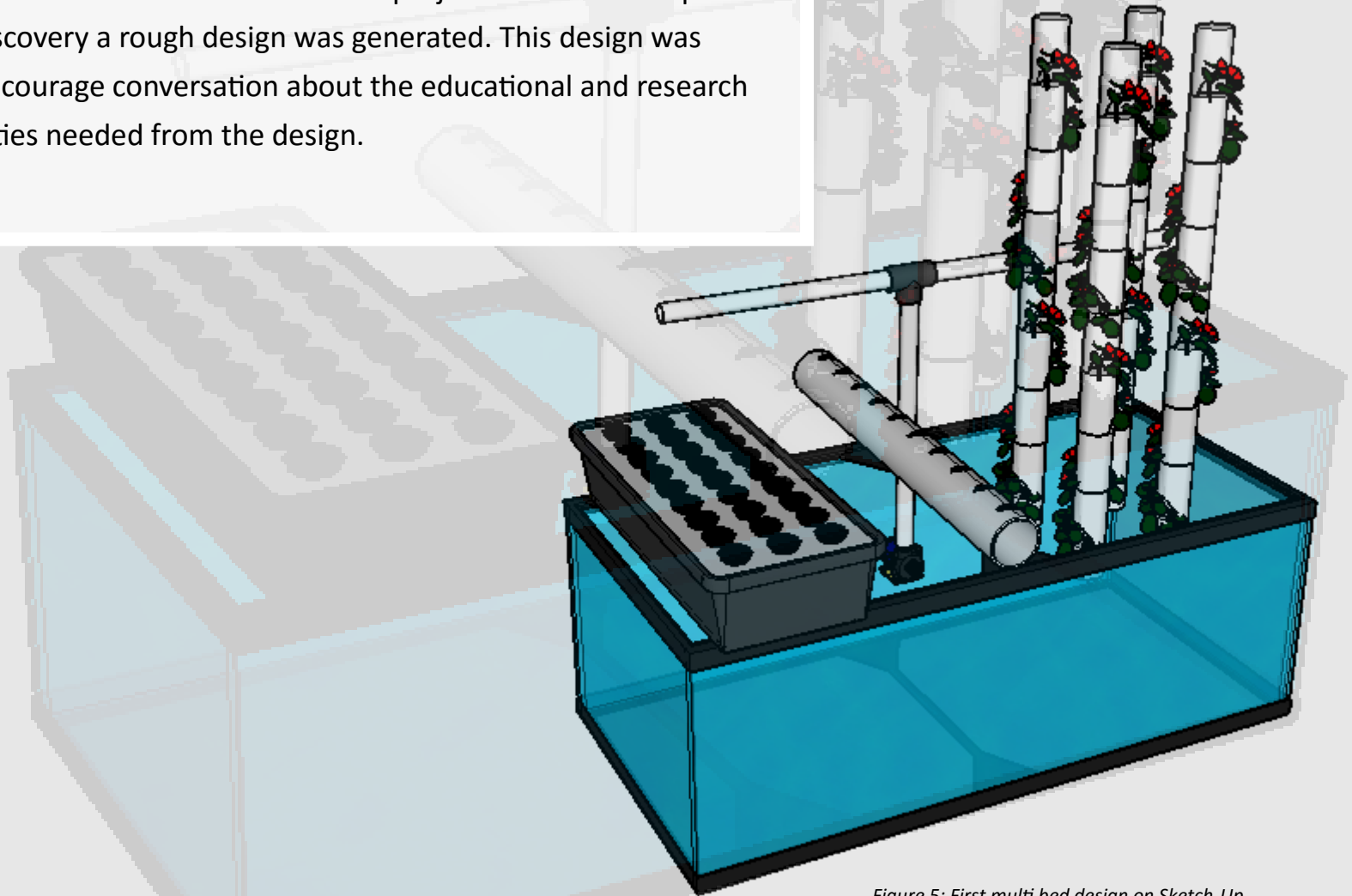



Figure 5: First multi bed design on Sketch-Up





From this early point of design development the social investigation was the main focus. As discussed in the methodology the social investigation was organized to recognize the specific needs of the different groups at the American Farm School. In the conversations and interviews that were conducted Education, Research objectives, Design Considerations, Social Accommodations, and Commercial Prospects arose as important themes to consider. The conclusions in each of these themes are condensed in the chart on the following page.

Perrotis
Professors

AFS
Teachers

Admin

Students

Education

Real world demonstrations and examples to supplement a number of topics in innovative agricultural methods

Easy to use small system for demonstrative purposes. Supplement lessons in chemistry, biology, and agriculture. Student involvement is key

School drives innovation in the community through education. This tactic can help drive urban development of systems

Students want more lab work to be worked into their curriculum. They are very interested in learning more about aquaponics

Research

Extreme interest in research on aquaponics. Desire testing different growing methods and plant growth rates

No interest in research.

No interest in research.

Interest in researching how aquaponics can help growth rates of plants

Design

Fast growing practical plants, hardy low maintenance fish, a modular system are desired

Small demonstrative design for educational use. Possibility of being marketed as an in home system. Colorful fish and fast growing plants best for teaching usage

System should be made to operate as practically as possible. Should be made to accommodate curriculum in place to help with implementation into the on campus community

Want the system to be practical. Conditions that make the system work the best

Social

Greeks eat lettuce and olive oil, and whatever vegetables are in season. Greece is used to fish from Aegean, freshwater fish wont sell

Must be able to spread ideas to the community. Greek people do not eat a lot of fresh water fish prefer fish from the sea. Students would be interested in aquaponics. Interested in

Innovation was initially where we were about, technical ways of doing things, but now the social way of doing things, change in the way of community work

Big opportunity to show community how the system works. Facilitate community understanding in aquaponics

Commercial

Before this is made as a commercial system it must be used and re-searched at a small scale

Small home system can be marketed. Possibility of trying to sell the idea of small in home aquaponics systems

System should have potential to scale up. Interest in having system demonstrate how aquaponics products can go from the system to market

Entrepreneurship club hopes to be able to sell the idea of aquaponics. Linking up with aquarium company

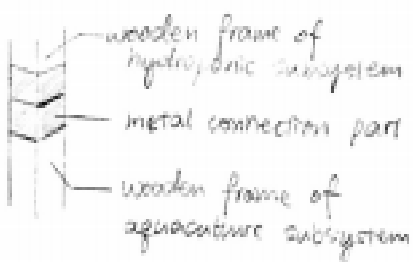

To make the system easy to maintain



To make the structure more stable

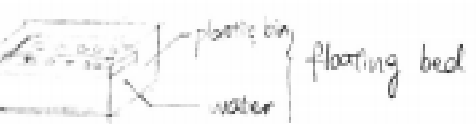

easy to start and maintain

Can observe plant root system development

good for demonstration
prof. filter with bottom pump



reduce the
easy to clean (change filter back)
make the system

increase the system's mobility
break would make sure the model stable enough for demonstration

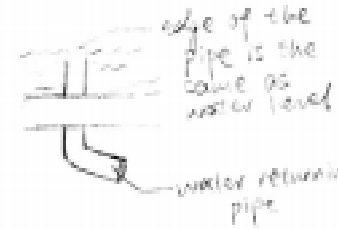
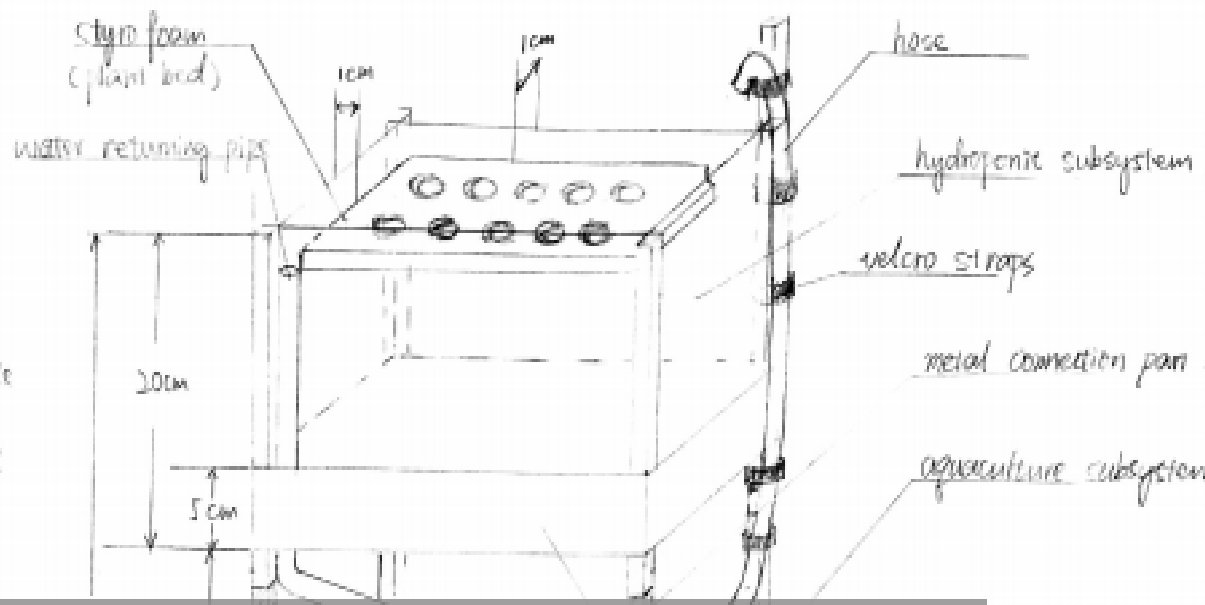

- the length of the pipe controls the water level of the plant bed

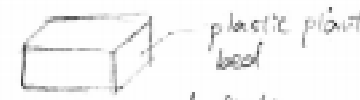

- cheap and light
- media to change to clay balls, gravels from water
- can be easily replaced

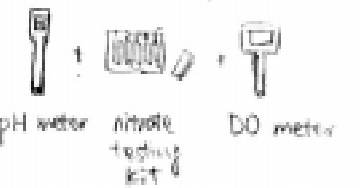

- testing tools for daily tests, especially important when start the system

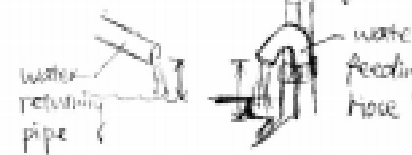

- space between pipes and water surface allow water trickling down and have more dissolve oxygen in the plant bed and aquarium tank

To continuously hone and vet the system a number of hand drawings including the design features being considered were produced. These drawings were shown to the various members of the AFS community to encourage discussion on the design parameters and features being considered. These discussions enabled the development of a final set of system requirements and design features. The discussions revolving around aquaponics as an educational tool all culminated into a small easily maintainable design to use as a demonstrative asset. The discussions on the research aquaponics system suggested that a bigger system equipped to facilitate experiment work was necessary.

The biggest conclusion made from the social investigation is that the school could most benefit from two aquaponics systems, one for educational purposes and the other for research objectives.

Educational Model

This model was developed to facilitate the course work at AFS. The educators, particularly at the AFS high school, indicated that the system could be useful for demonstrating important topics such as the plant growth cycle, microbiology, and the nutrient cycle. The design also needed to be small, mobile and easy to maintain.

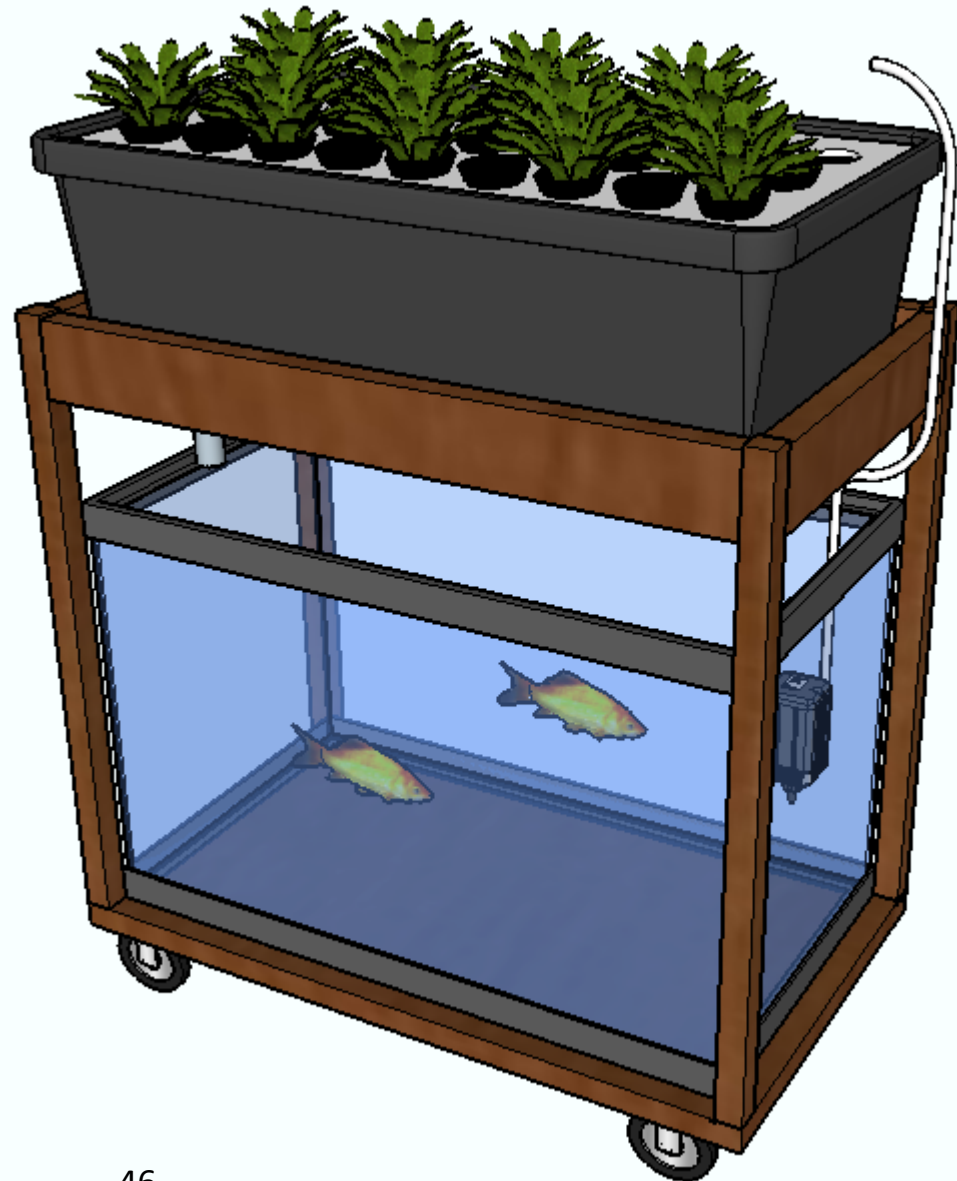

SIZE

The vast majority of interviewees, especially the high school teachers, wanted a small model of aquaponics on campus. For example, AFS agricultural teacher Ioannis Milonas, requested to “make it small and really simple.” Since aquaponics is a new concept to most educators, it is important to start with a small model so the teachers can learn on a system that is easy to maintain. To meet this requirement, the educational model was designed to use a common 60L aquarium tank. The total dimensions of the educational model are 0.6mX0.3mX0.80m. This size was chosen in order to fit into both the classroom and lab.

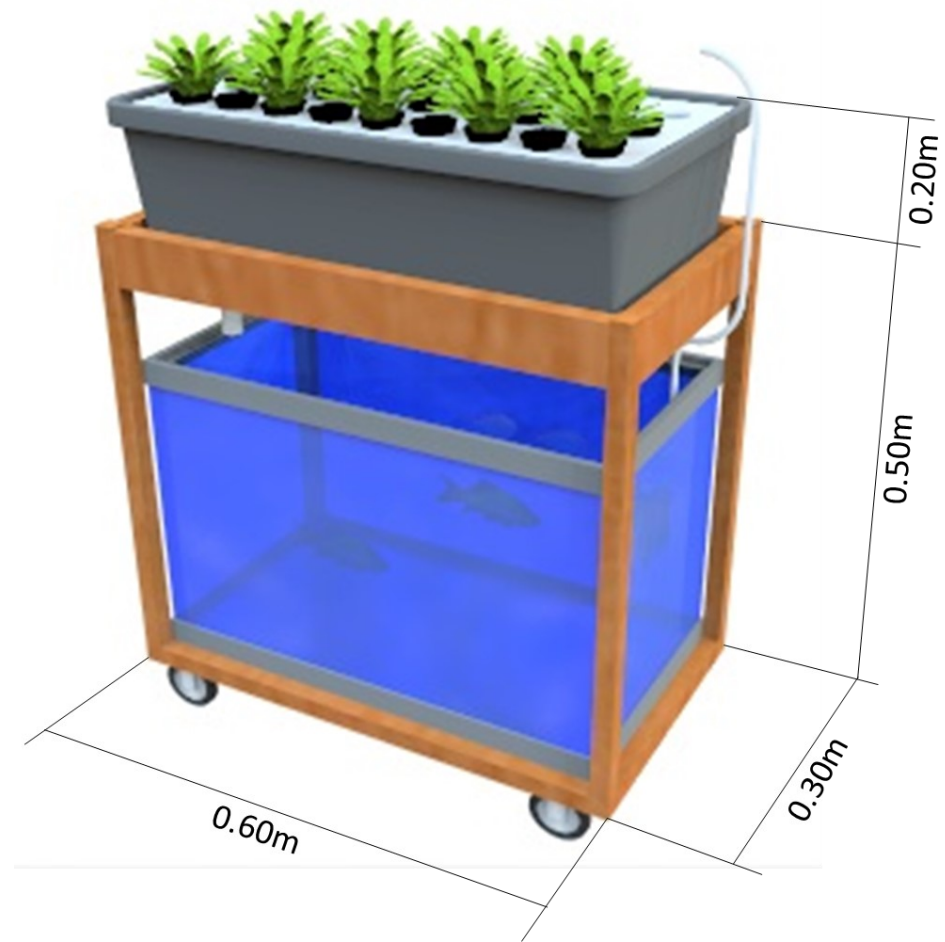

Figure 6: Educational design with dimensions



LOCATION

It is clear that high school teachers are interested in using aquaponics in both classroom and laboratory settings. When asked about the usage of aquaponics Mr. Milonas stated that the system could, “support the knowledge taught and have it in the lab to help students understand the concepts.” Professor Christos Vasilikiotis in the Environmental System Management (ESM) department at Perrotis College also stated, “I want a demonstration of what I’m talking about in class.” Students also expressed their interest in doing more labs along with their classes. They think it would be helpful if the system can be used for lab testing along with the lectures. To accommodate different requirements from faculty members and students, the small system was designed to be located in both classrooms and laboratories.

FISH CHOICE

In the early stage of the social investigation Professor Vasilikiotis suggested to use ornament fish in the educational model. He said “I think the best species for the aquaculture are goldfish and guppies.” Other members of campus also agreed with the idea of using ornamental fish. For example, AFS biology teacher Antonia Kotoula mentioned in her interview that she wanted to use goldfish for demonstration since they are, “small and easy.” As one of the most popular ornamental fish, goldfish is aesthetically appealing and easy to maintain. Goldfish are able to survive rougher temperature conditions, such as cold water. They can also be easily acquired from any aquarium store. Being easy to access, maintain, and visually appealing, gold fish are the most appropriate choice.

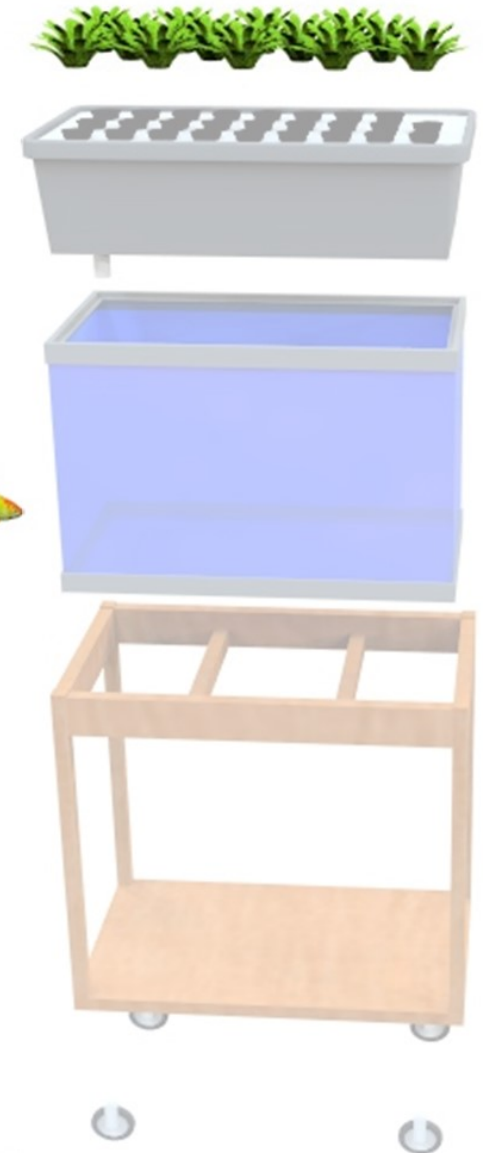



PLANT CHOICE

Many faculty members expressed their interest in using the educational model to demonstrate the plant life cycle. For example, Ioannis Milonas mentioned, “I can add the system in lessons of plant production, it would be useful.” Also, professors from the ESM department think the aquaponics system can be used in class for students to explore plant growth and nutrient uptake. Most faculty members want to use plant species that can grow fast so the students can observe the entire plant life cycle during the semester. Professor Vasilikiotis suggested to use leafy vegetables, such as lettuce, since they, “grow fast and require a less complex system.” After discussing this idea with ESM Department head, Dr. Gertsis, he agreed that using a fast growing plant would be beneficial for aquaponics education. Students also want the system to be as practical as possible and use plants that are commonly used in aquaponics, even if they are not as visually appealing.

GROW BEDS

There are many different types of grow beds that can be implemented in an aquaponic system. Depending of the type of grow bed selected, the cost and maintenance requirements vary. Educators made it clear that they want a system that is easy to use and maintain. Dr. Gertsis recommended that in order to keep the hydroponic subsystem as simple as possible, a floating plant bed should be used. Its maintenance requirements are straightforward and its rate of biomass production is high. Moreover, according to Antonia Kotoula and Professor Vasilikiotis it would be useful if the root systems could be put on display for conceptual explanations. The floating bed system provides that option. The plants grow on a floating styrofoam mat that can be easily lifted to view the root systems. In order to maintain the simplicity and the visual requirements of the educational model, the floating bed was selected as the hydroponic subsystem.

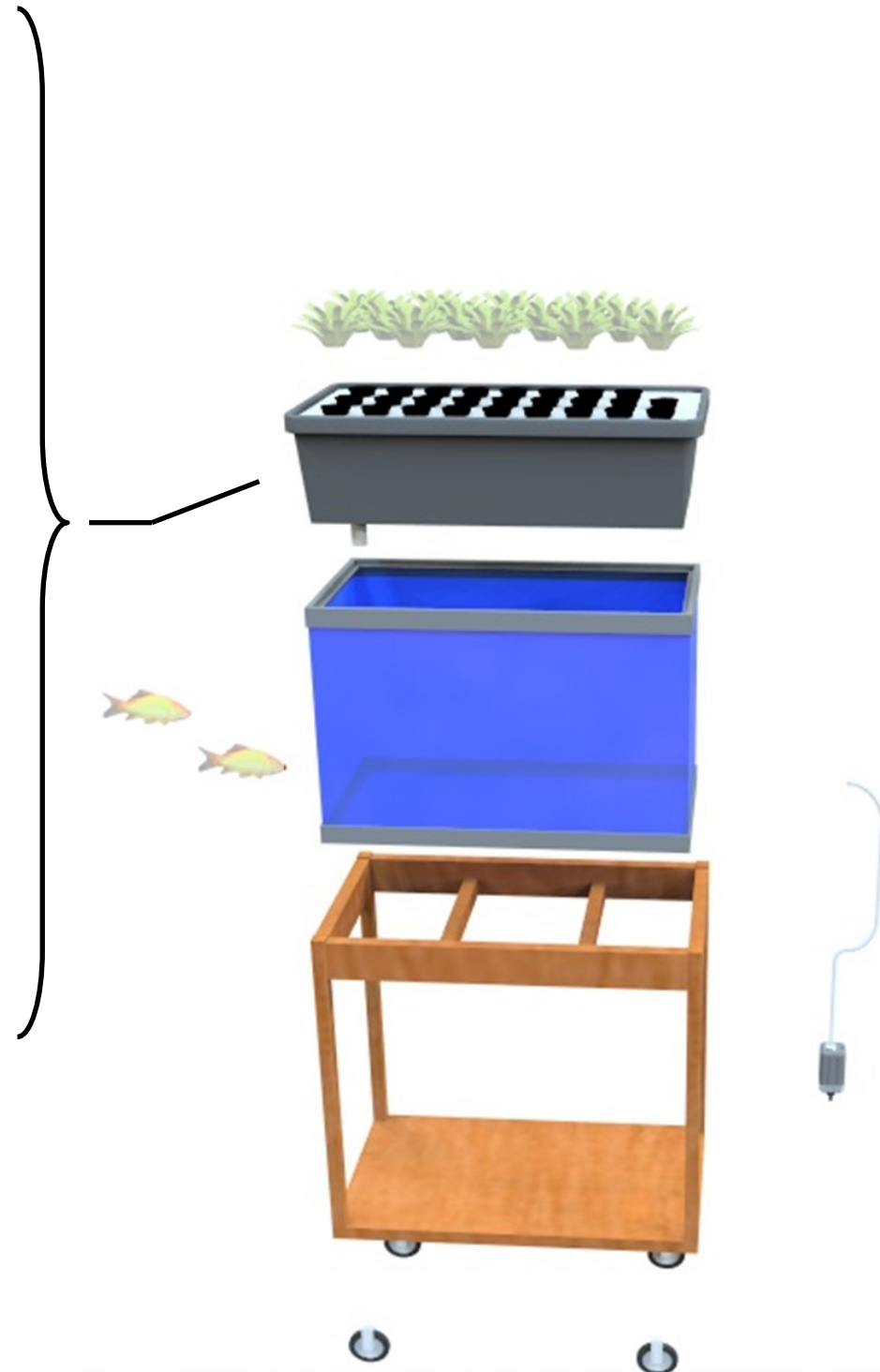



MECHANICAL

The different components of the aquaponics system are integrated together with a simple wooden frame. A wooden frame was chosen because the material is cheap, can support the weight of the system, and is aesthetically pleasing. The system also needs a pump and a hose to circulate the nutrient rich water to the plants. In this design, a standard small aquarium pump is used because it is readily available, cheap, and has enough power to circulate the water. The glass fish tank was chosen in order to display the decorative fish. To make the system more mobile so AFS teachers could relocate it between different classrooms and labs, wheels were added to the design. Dimitrios Slavovdis, the project director at AFS, said “I think that the wheels are a great idea.”

COST ANALYSIS

For the implementation of the system at AFS it is important to take into account budget constraints. For the educators and administration to have a broader idea of the financial requirements of the system, a cost analysis was made. Prices were based off of local Thessaloniki stores and online retailers.

Material	Cost
Aquarium Tank	€ 110 for a 60x30x30cm 54 liters Blue Fish Aquariums and pets
Wooden frame	€5 for 33x48x3000 mm
-Wood	Estimated 10 euro for frame
-paint	€1,20
Pump (at least 300 LPH)	~€8,00 (amazon)
Hose	€3,99 for 5 meters Prakiter hardware
Hydroponic tank	€3,99 from Prakiter hardware
Hydroponic styrofoam	€1 Prakiter hardware
Fantail goldfish	€ 3,19 Pet Smart
Fish food	€2 Goldfish Flakes 12g Tropicana at Blue Fish Aquariums and pets
Total Estimate	€ 138,37

Table 2: Cost analysis of education model

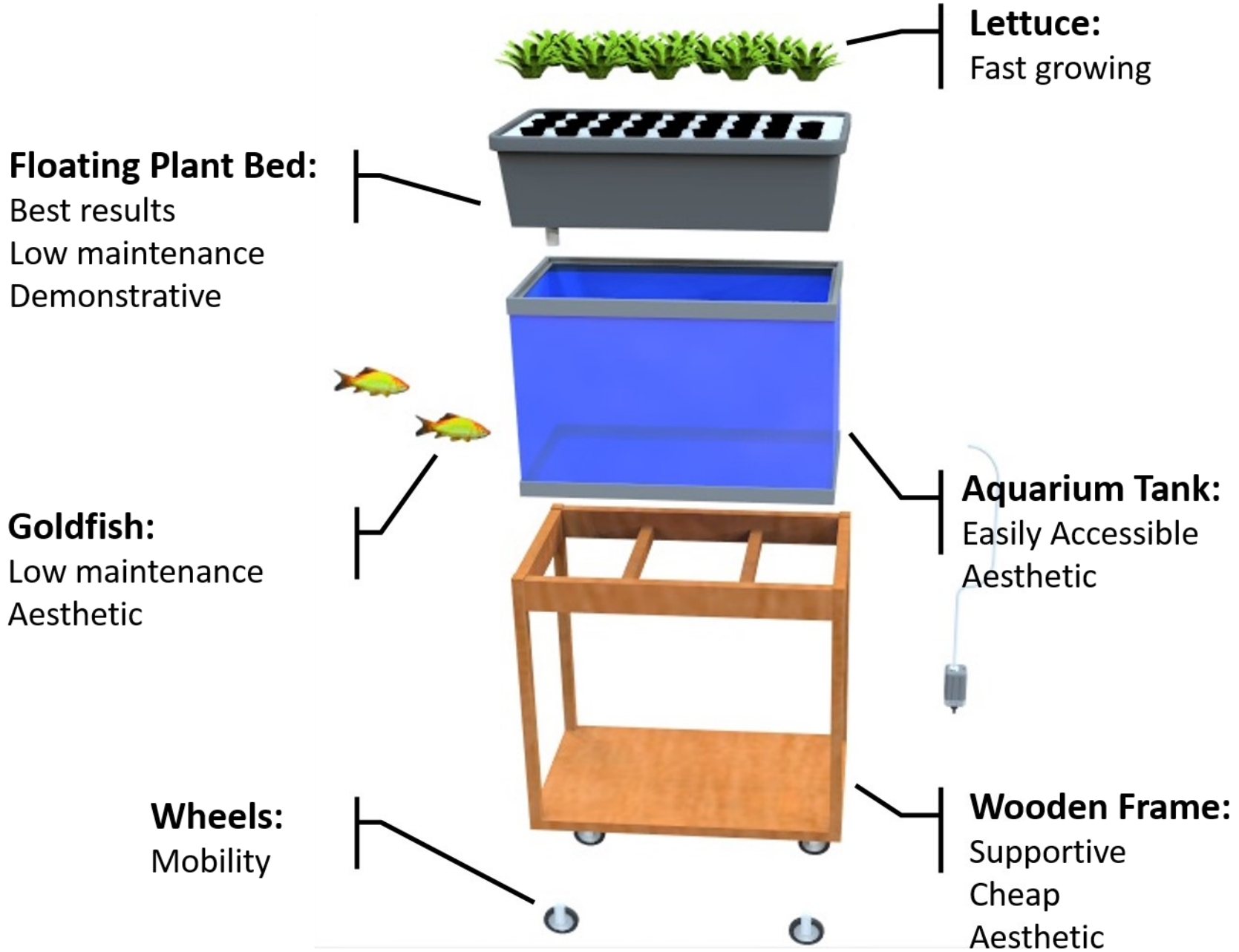
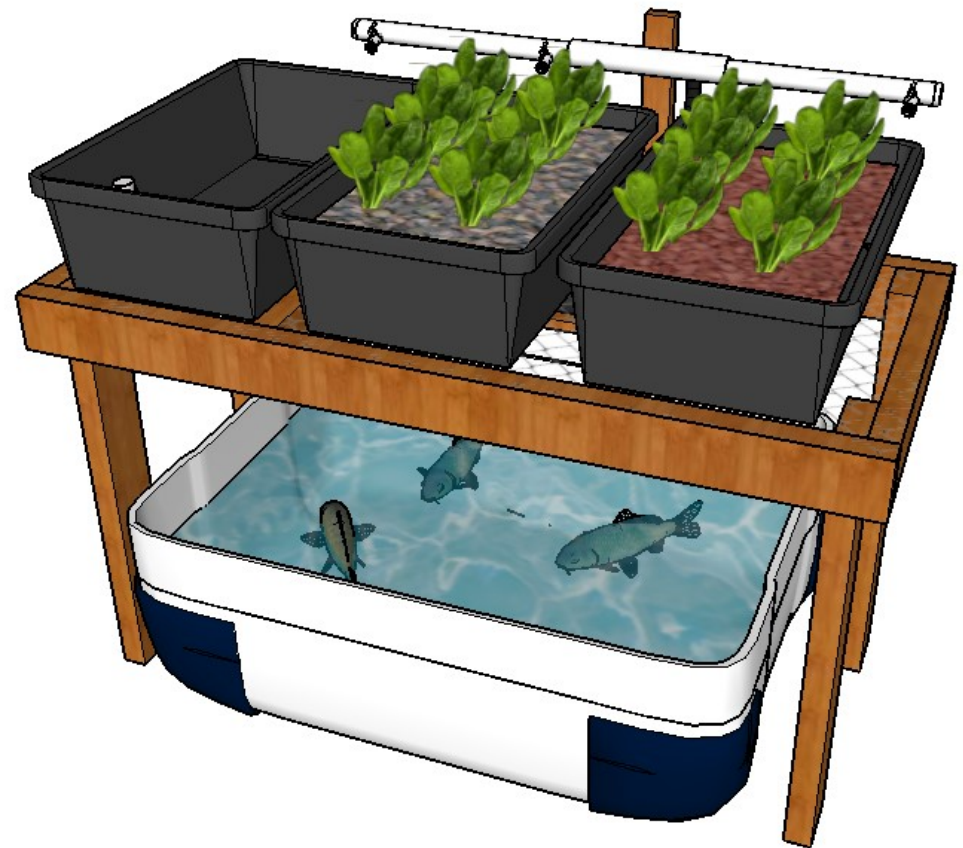

Figure 7: Exploded diagram of educational system

Research Model

The purpose of the research design is to accommodate for the desires of both administrators in the technical works department, as well as professors from Perrotis College. The design will allow students and professors to experiment with aquaponics systems. The reasoning behind many of the features selected in the research design presented was to lay the foundation for scaling up possibilities, while still addressing the needs of researchers. The design was made to be as customizable as possible to take into account possible research interests and commercialization prospects.





INTERNATIONAL RESEARCH
& TRAINING CENTRE
FOR SUSTAINABILITY

LOCACTION

Administrators, students, and Perrotis College professors believed that the greenhouse was the best location for the research model. According to Antonis Petras, head of the technical works department, the best place on campus to house such a system would be the greenhouses on campus because it provides for the space requirements of the system. The student population reached a similar consensus. One student expressed this opinion by saying, "You should build the system in the greenhouse so everyone can see it."



FISH CHOICE

One common theme that arose among all the groups interviewed was that Greeks do not typically eat freshwater fish. With the Aegean Sea providing saltwater fish, there is little interest in the consumption of the freshwater fish species on a regular basis. However, Dr. Gatzolis, head of the Horticulture department stated that, “Smoked freshwater fish are commonly served as appetizers.” One of the common smoked freshwater fish that is served is the Common Carp (*Grivadi in Greek*).



Carp are an excellent choice for aquaponics systems. They are able to survive within a wide range of water conditions and can live in both cold and warm water. Resilience to the varying temperatures that occur in the greenhouses throughout the year was an essential trait looked for in a fish choice. This allows the design to not need a heater to control the water temperature. Carp can survive in a wide range of pH, ammonia, and dissolved oxygen levels. The low oxygen requirement of carp enable them to live comfortably in water stimulated by the turbulent return lines, removing the need for external oxygenation systems (FishPlant, 2016).

For the size of the research design we proposed here, a stocking density of 1.4 kg/m^3 is optimal for growing spinach (Hussain et al., 2014). For the proposed system this equates to 15 carp. Carp can be purchased when they are 3-4 inches in length for a price of 2.00€/Fish (The Carp Co). For ideal carp growth and nitrogen conversion rates, the feed for the fish needs to be composed of 23-35% protein and 6% fat (Tacon, 2016). Cost estimates for the food to use with the research design are approximately 1.80€/kg of food (PurePellet, 2016).



Kontrolmag.com

Spinach is efficient in nutrient absorption. In order to make sure that the aquarium stays within the optimal conditions for the carp, the nutrient absorption needs to be done efficiently. With a carp stocking density of 1.4 kg/m^3 , 28 spinach plants/ m^2 are recommended to be grown. This quantity of spinach is optimal, for a 80% nitrogen uptake that will provide excellent growing conditions for the fish (Hussain et al., 2014).



PLANT CHOICE

When determining the ideal plant to accompany the carp in the research design it was important to consider the potential for scale-up of the system for commercial purposes. When asked about what vegetables should be used in the system Mr. Gatzolis stated, “Spinach is a good choice because it can be frozen and sold later.” Other researchers in ESM were interested in leafy green vegetables because of their fast growth rates and their usefulness in testing nutrient uptake.

GROW BEDS

One research aspect that was of particular interest to Perrotis College researchers was being able to conduct comparison studies using the same system. Vasilikiotis stated that doing side by side studies with different grow beds would be beneficial for the research process. Both Vasilikiotis and Eleni Topalidou hope to use the research system in order to test how different growing media can improve plant growth. Traditional aquaponics systems typically use either gravel, clay balls, or floating styrofoam beds. The multiple grow beds and modular design allow for the user to use various grow media to accommodate for any research desired.

The grow beds for the research design will be 0.4mX0.55mX0.2m. The beds will be made out of plastic in order to keep the price low as well as being able to support the volume of growing media and water in each bed. Each will have a standing pipe going through the bottom of the grow bed. These standing pipes can be adjusted in order to accommodate for the different growing depths needed for various plants. The design was made for the grow beds to be removable in order to switch out different beds for different systems.



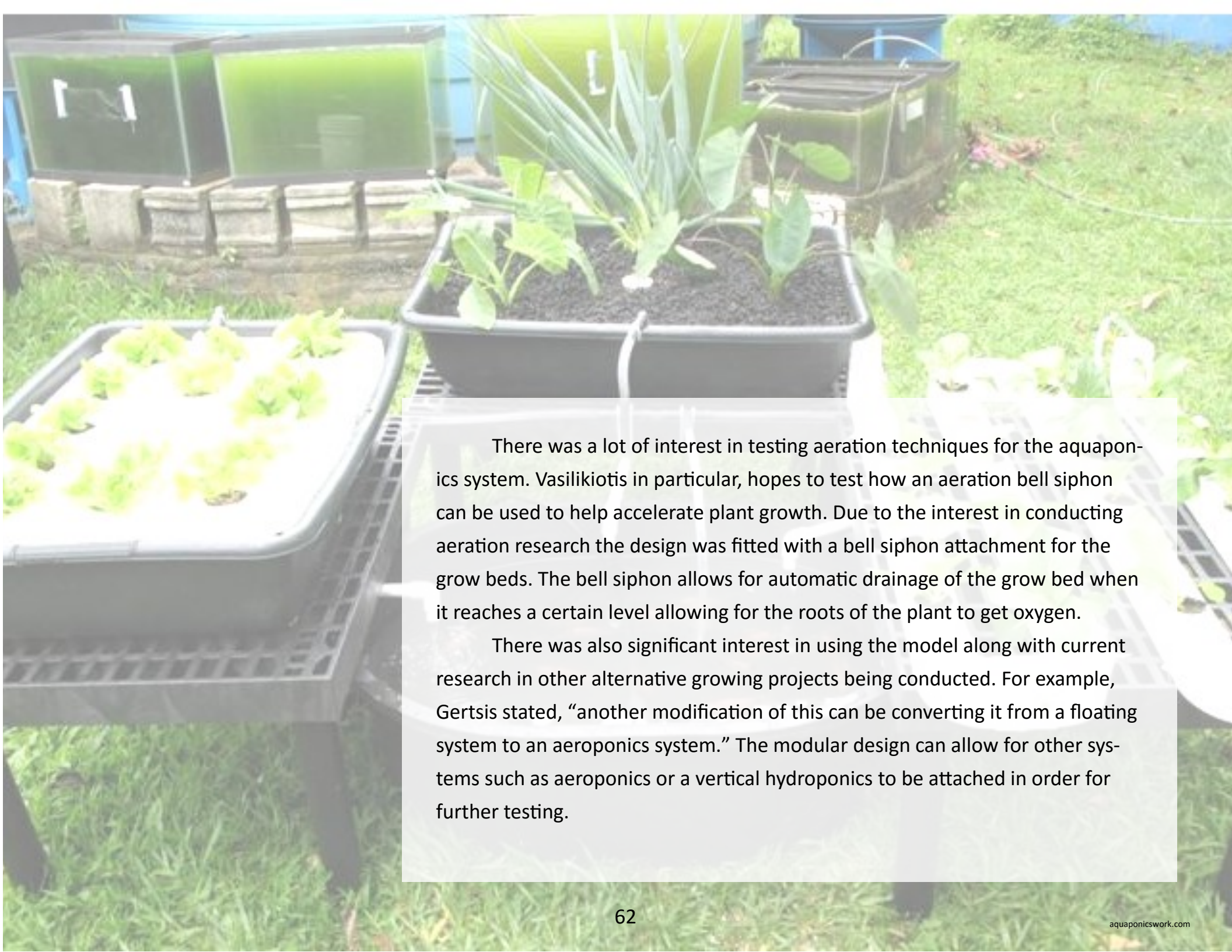

There was a lot of interest in testing aeration techniques for the aquaponics system. Vasilikiotis in particular, hopes to test how an aeration bell siphon can be used to help accelerate plant growth. Due to the interest in conducting aeration research the design was fitted with a bell siphon attachment for the grow beds. The bell siphon allows for automatic drainage of the grow bed when it reaches a certain level allowing for the roots of the plant to get oxygen.

There was also significant interest in using the model along with current research in other alternative growing projects being conducted. For example, Gertsis stated, “another modification of this can be converting it from a floating system to an aeroponics system.” The modular design can allow for other systems such as aeroponics or a vertical hydroponics to be attached in order for further testing.

FRAME AND FISH TANK

The dimensions of the frame of the research design will be 1.25x0.6x1.0m. The frame will consist of a rectangular wooden table. The top of the table will have three holes supported by chicken wire webbing for the grow beds to sit on. Chicken wire webbing was chosen because it allows the design to be lighter and easier to move if necessary. Behind the frame will be a wooden tower to support the pump and piping that will circulate the water from the fish tank to the grow beds. The tower will consist of a small base to support a beam that goes to a height of 1.5 meters. This will allow the piping to be 0.3 meters above the top of the grow bed allowing the water to trickle down to the plants helping oxygenate the water.



Figure 8 Research design with dimensions

Beneath the table will be a fish tank with dimensions of 0.8x0.55x0.6m (0.264m³). This size fish tank will provide enough water for the fish to live in as well as enough to use in the grow beds. The size of the fish tank is meant to accommodate for the expected growing rates of carp. This means more water can be added to keep the tank from getting overcrowded.



PIPE AND PUMP

The piping will be supported by the tower in the framework of the design. At the top of the tower the piping will diverge into three separate streams. Each stream will have its own separate valve allowing each grow bed to be turned on or off individually to further emphasize the modular aspects of the designs.

The pump that will circulate the water for the system will also double up as a biofilter. This biofilter will contain biological filter media. This media consists of porous rings that collect solid waste created by the fish and facilitate the growth of essential bacteria in the system.

COST ANALYSIS

For the implementation of the system at AFS it is important to take into account budget constraints. For the educators and administration to have a broader idea of the financial requirements of the system, a cost analysis was made. Prices were based off of local Thessaloniki stores as well as online retailers.

Material	Cost
Wooden frame	€5 for 33x48x3000 mm €6.79 for 48x48x3000 mm Estimated €20 for wood frame
Chicken Wire	€11.99 for 3 meters (prakiter hardware)
Wheels	€4.99 per wheel (prakiter hardware)
Pump (at least 8000 GPH)	~€200 (amazon)
Piping System	€8.99 for 10 meters (prakiter hardware)
Plastic Fish Tank	€9.99 (prakiter Hardware) Likely free as a recycled bin
Common Carp	€ 2 per fish
PVC piping	€5,00 for 3 meters (prakiter hardware)
Grow Bed	€5,00 per system (prakiter hardware) Note: depending on what type of system is used, cost will vary
Total Estimate	€ 278

Table 3: Cost analysis of research model

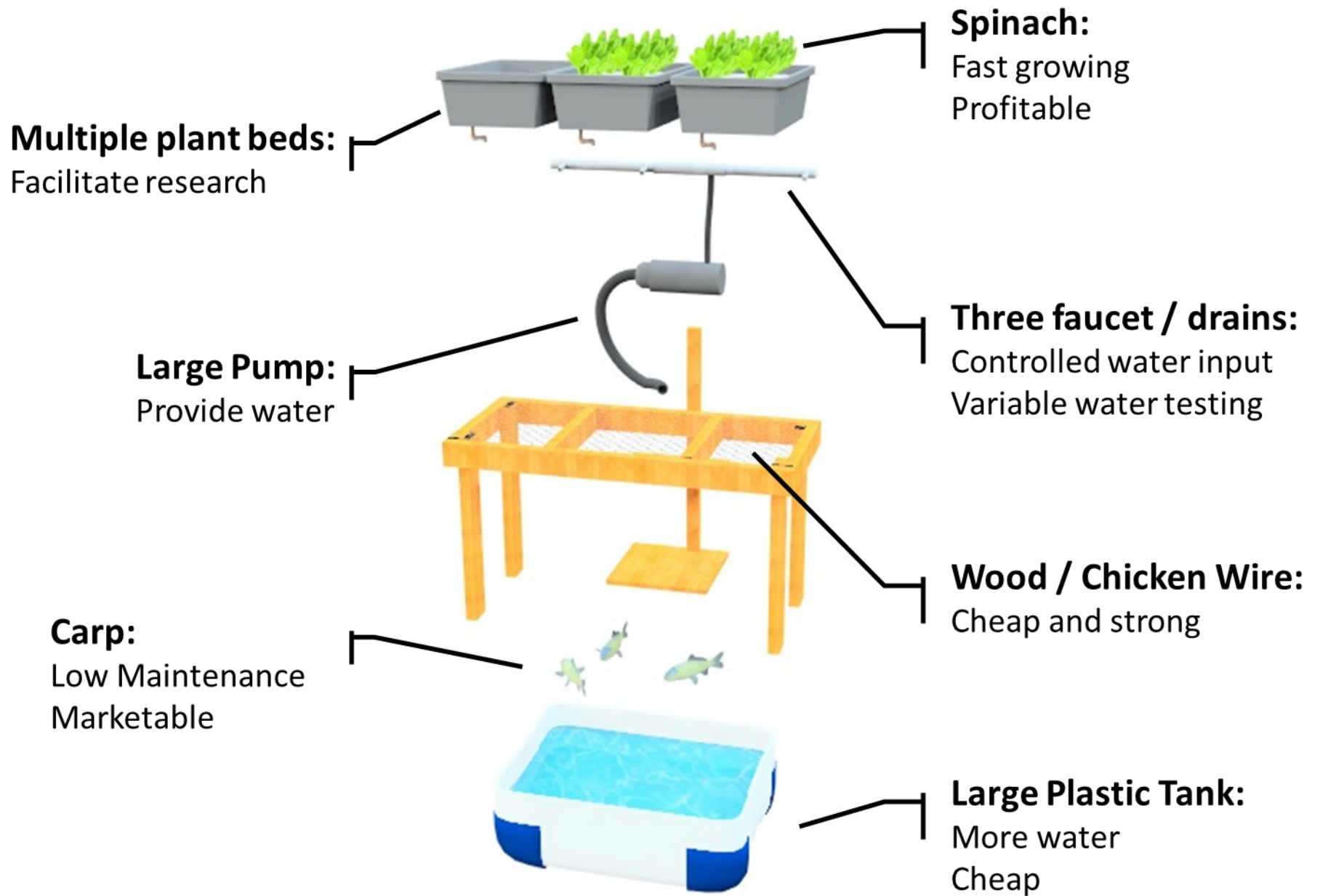

Figure 9: Exploded diagram of research system

MAINTENANCE

Both designs will require maintenance every day to make sure they are operating correctly. The fish must be fed every day in order to support the system. The research design must be maintained more carefully. The carp in this system should be fed approximately 2% their body weight in food per day in order to achieve the appropriate growth rates and to produce enough nutrients for the

plants. The chemical levels also need to be carefully monitored in order to ensure the system does not fail. The major concern is that the temperature, pH, dissolved oxygen, and ammonia levels can stray too much due to poor filtration and cause the carp stress and possibly death. The optimal living conditions for the carp are outlined in the table below (FishPlant, 2016).

	Optimal Conditions	Livable Conditions
pH	6.5-9	6.5-9.5
Temperature (°C)	23-30	3-35
Non-Ionized Ammonia (mg/L)	0-0.04	—
Nitrate (mg/L)	<50	—
Dissolved oxygen	5 mg/L	1-10 mg/L
Stocking density	1.4 kg/m ³ (15 fish)	—

Table 4: Water quality

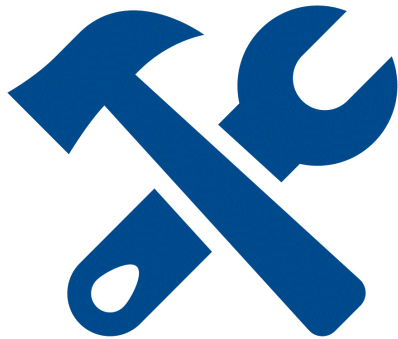

The systems will also need to be cleaned if there is a buildup of solid fish waste. The educational model can be cleaned easily by simply removing the plant bed and clearing out all solids from the tank and bed. The large scale system will be more intensive because the table will need to be moved in order to clean the fish tank, and there will be more waste build up due to the larger fish.

To properly maintain both systems the student work study program at the school should be utilized. Dean of Student Services, Eva Kanellis, explained the work study program, “[provides] a scholarship, but you have to give something back to the community, such as social commitment.” Being able to have students help with maintenance is a very cost efficient way to manage the system. However, when school is not in session educators and administration felt it will be a financial and time burden to maintain the system. As discussed with project sponsor Mr. Nikolas Nikolaidis, the best option currently is to harvest the fish and plants at the end of the school year and shutdown the system until the next school year begins.

Future implementation

Another aspect explored was how the aquaponics system designed for AFS and Perrotis College can be modified for implementation outside of the curriculum. In the interviews with on campus stakeholders, inquiries were made for real-world implementation opportunities of aquaponics. This investigation explored the possibility of future commercial opportunities for aquaponics system.

During the interviews investigating aquaponics inside the school, each interviewee was asked about any potential they saw for the system to be implemented in an applied, or non-educational setting. Their recommendations were further investigated, typically with short interviews with members of the community or local businesses. In these interviews, aquaponics designs were explained to the potential user with the examples shown in Appendix 4. The possibilities of implementing aquaponics into their organizations were discussed. This data was collected to generate recommendations about how AFS can integrate aquaponics into a the broader Greek community.

Aquaponics technology is widely recognized for its potential as an urban agriculture tool. It can be implemented in a number of different ways. The initiative at AFS and the production of the two designs proposed here are the beginning of the development of aquaponics. The small educational design can act as a model for the development of household systems. A household aquaponics system could provide families with a supply of fresh vegetables and fish. The entrepreneurship club on AFS campus as well as an aquarium shop owner in Thessaloniki both suggested that this would be a promising way to propagate aquaponics into the community.

However, this is not the only possibility. Larger community or commercial systems could be developed to bring mass food production into urban landscapes. This system would resemble many of the other aquaponics facilities around the world. The school's researchers and administrators suggested that they wanted to expand the aquaponics program in order to develop a system of this magnitude. However, before either of these future designs can be implemented, aquaponics technology must first be further investigated. The research aquaponics system was designed to facilitate this process of better understanding the technical parameters of the system. Further research into the needs and desires of end users will also need to be conducted.





With the appropriate investigation, aquaponics can be expanded from the American Farm School into the broader Greek community. Driving innovation in agriculture is part of the school's history. According to Eva Kanellis, "AFS has a history of driving changes in agriculture in the Balkan region" and "aquaponics is an extremely innovative technology ... [that can significantly contribute to] continuing the innovation of the school."



This project followed the social investigation and design process of aquaponics at the American Farm School. The American Farm School, as a driving force of agriculture innovation wants to investigate aquaponics and its future in the Balkan region. An iterative design process, relying heavily on end user perspectives, was used to develop designs of aquaponics systems for educational and research purposes. The small model emulates the features of a small household aquaponics system while acting as an educational tool. The larger research system enables the school's researchers to perform the appropriate tests on aquaponics as an agricultural process to better understand how to develop an optimized system for commercial purposes.

Work cited

Adams, V., Burke, N. J., & Whitmarsh, I. (2014). Slow research: Thoughts for a movement in global health. *Medical Anthropology*, 33 (3), 179-197. doi:10.1080/01459740.2013.858335

Advantages and Disadvantages Of In Depth Interviews Psychology Essay. (n.d.). Retrieved February 15, 2016, from <http://www.ukessays.com/essays/psychology/advantages-and-disadvantages-of-in-depth-interviews-psychology-essay.php>

Agriculture and rural development - European Commission. (n.d.). Retrieved January 24, 2016, from http://ec.europa.eu/agriculture/index_en.htm

Alderman, L. (2013, 20130417). More Children in Greece Start to Go Hungry. Retrieved from <http://www.nytimes.com/2013/04/18/world/europe/more-children-in-greece-start-to-go-hungry.html>

Al-Hafedh, Y. S., Alam, A., & Beltagi, M. S. (2008). Food production and water conservation in a recirculating aquaponic system in Saudi Arabia at different ratios of fish feed to plants. *Journal of the World Aquaculture Society*, 39(4), 510-520. doi:10.1111/j.1749-7345.2008.00181.x

Allegheny aquaponics. (n.d.). Retrieved February 03, 2016, from <http://www.foodforsustainability.com/#!/story/c1ozp>

Aquaponics Philippines | Serving aquaponics enthusiasts in the Philippines. (2016, April). Retrieved February 21, 2016, from <http://aquaponicsphilippines.com/>

Beattie, Jason. Greece debt crisis: Tourists warned to take their own medicine on holiday as chemists run short of stock; TRAVELLERS to Greece are being advised to be prepared for shortages of medical supplies and possibly food and fuel as the country stands on the brink. (2015). (pp. NEWS, UK & WORLD).

Bernstein, S. (2011). *Aquaponic gardening: a step-by-step guide to raising vegetables and fish together*. New Society Publishers.

Bbcworld. (2015). The Greek debt crisis story in numbers - BBC News. Retrieved from <http://www.bbc.com/news/world-europe-33407742>

Berg, B. L. (2004). *Qualitative research methods for the social sciences (5th ed.)*. Boston: Pearson.

Brown, T. (2008). Design thinking. *Harvard business review*, 86(6), 84.

Cooley, M. (2000). Human-centered design. *Information design*, 59-81.

Charmaz, K and Mitchell, R.G. (2001) Grounded Theory in Ethnography. In *Handbook of Ethnography*. P Atkinson, A Coffey, S Delamont, J Lofland, and L Lofland (eds). Pp. 160-174.

Chrysopoulos, P. (2015). Food Prices in Greece Show Highest Increase Among EU 28 | GreekReporter.com. Retrieved from <http://greece.greekreporter.com/2015/11/09/food-prices-in-greece-show-highest-increase-among-eu-28/>

Eatmon, T., Pallant, E., & Laurence, S. (2015). Food production as an integrating context for campus sustainability. In *Implementing Campus Greening Initiatives (pp. 325-336)*. Springer International Publishing.

Tacon, A. G. J. (2016). FISH FEED FORMULATION AND PRODUCTION. Retrieved from <http://www.fao.org/3/content/3e2fac62-0799-5350-a0ba-b12a6416d65f/U4173E00.htm>

TheEconomist. (2015b, 2015-03-04 12:03:00). The agony of Greece. Retrieved from <http://www.economist.com/blogs/graphicdetail/2015/03/daily-chart-0>

Ganello, L. (n.d.). Food System Lab @ Cylburn. Retrieved April 23, 2016, from <http://www.jhsph.edu/research/centers-and-institutes/johns-hopkins-center-for-a-livable-future/projects/aquaponics/>

Grace Communications Foundation. (2016). Impacts of Industrial Agriculture. Retrieved from <http://www.sustainabletable.org/869/impacts-of-industrial-agriculture>

Greeks. run out of cash; Food shortages loom within days. (2015, July 4). *The Free Library*. (2015). Retrieved February 25, 2016 from <http://www.thefreelibrary.com/Greeks.run.out.of.cash;Food.shortages.loom.within.days.-a0420437595>

GRRReporter. (2016). Record hike in Greek food prices. Retrieved from http://www.grreporter.info/en/record_hike_greek_food_prices/13526

Goddek, S., Delaide, B., Mankasingh, U., Ragnarsdottir, K., Jijakli, H., & Thorarinsdottir, R. (2015). Challenges of sustainable and commercial aquaponics. *Sustainability*, 7(4), 4199-4224. doi:10.3390/su7044199

Hart, E. R., Webb, J. B., & Danylchuk, A. J. (2013). Implementation of Aquaponics in Education: An Assessment of Challenges and Solutions. *Science Education International*, 24(4), 460-480.

Hartocollis, A. (2015, 20150711). Greece Financial Crisis Hits Poorest and Hungriest the Hardest. Retrieved from <http://www.nytimes.com/2015/07/12/world/europe/greece-debt-crisis-athens-poverty-inequality.html>

Henley, J. (2015a). Greece's solidarity movement: 'it's a whole new model – and it's working'.

Henley, J. (2015b). 'Making us poorer won't save Greece': how pension crisis is hurting its people.

Hu, Z., Lee, J. W., Kim, S., Brotto, A. C., & Khanal, S. K. (2015). Effect of plant species on nitrogen recovery in aquaponics. *Bioresource technology*, 188, 92-98.

Hussain, T., Verma, A. K., Tiwari, V. K., Prakash, C., Rathore, G., Shete, A. P., & Nuwansi, K. K. T. (2014). Optimizing Koi Carp, *Cyprinus carpio* var. Koi (Linnaeus, 1758), Stocking Density and Nutrient Recycling With Spinach in an Aquaponic System. *Journal of the World Aquaculture Society*, 45(6), 652-661. doi:10.1111/jwas.12159

Intensive Farming. (2016). Retrieved from <http://www.everythingconnects.org/intensive-farming.html>

Jon Schneller, A., Schofield, C. A., Frank, J., Hollister, E., & Mamuszka, L. (2015). A Case Study of Indoor Garden-Based Learning With Hydroponics and Aquaponics: Evaluating Pro-Environmental Knowledge, Perception, and Behavior Change. *Applied Environmental Education & Communication*, 14(4), 256-265. doi:10.1080/1533015X.2015.1109487

Katsikas, D., Karakitsios, A., Filinis, K. & Petralias, A. (2015). *Social Profile Report on Poverty, Social Exclusion and Inequality Before and After the Crisis in Greece*. Retrieved from <http://crisisobs.gr/en/2015/01/ekthesi-gia-to-kinoniko-profil-tis-elladas-se-schesi-me-ti-ftochia-ton-kinoniko-apoklismo-ke-tin-anisotita-prin-ke-meta-apo-tin-ekdilosi-tis-krisis/>

- Katz, G. (2015, 2015-07-03). Greek villagers' secret weapon: Growing their own food. Retrieved from <http://www.businessinsider.com/greek-villagers-secret-weapon-growing-their-own-food-2015-7>
- Kolokouris, O. (2015). Urban gardening in Greece – A new form of protest. *Green European Journal*, 11.
- Lennard, W. A., & Leonard, B. V. (2006). A comparison of three different hydroponic sub-systems (gravel bed, floating and nutrient film technique) in an aquaponic test system. *Aquaculture International*, 14(6), 539-550. doi:10.1007/s10499-006-9053-2
- Longhurst, R. (2003). Semi-structured interviews and focus groups. *Key methods in geography*, 117-132.
- Love, D. C., Fry, J. P., Li, X., Hill, E. S., Genello, L., Semmens, K., & Thompson, R. E. (2015). Commercial aquaponics production and profitability: Findings from an international survey. *Aquaculture*, 435, 67-74. doi:10.1016/j.aquaculture.2014.09.023
- Lowen, M. (2016). Greeks ditch middleman to embrace 'potato revolution' - BBC News. Retrieved from <http://www.bbc.com/news/world-europe-17369989>
- Mougeot, L. J. A., International Development Research Centre (Canada), & Ebrary Academic Complete. (2006;2005;). *Growing better cities: Urban agriculture for sustainable development*. Ottawa: International Development Research Centre.
- Nardelli, A. (2015). Unsustainable futures? The Greek pensions dilemma explained.
- Papadopoulos, S., Karelakis, C., Zafeiriou, E., & Koutroumanidis, T. (2015). Going sustainable or conventional? evaluating the CAP's impacts on the implementation of sustainable forms of agriculture in greece. *Land use Policy*, 47, 90-97. doi:10.1016/j.landusepol.2015.02.005
- Parr, D. M., Trexler, C. J., Khanna, N. R., & Battisti, B. T. (2007). Designing sustainable agriculture education: Academics' suggestions for an undergraduate curriculum at a land grant university. *Agriculture and Human Values*, 24(4), 523-533.
- FishPlant. (n.d.). FishPlant System User Guide. Retrieved April 22, 2016, from <http://www.fishplant.co.uk/fishplant-user-guide-web.pdf>
- Rahman, P. M. M., Matsui, N., & Ikemoto, Y. (2013). Poverty and Food Security. In *Dynamics of Poverty in Rural Bangladesh* (pp. 101-109). Springer Japan.
- Redwood, M. (Ed.). (2012). *Agriculture in urban planning: generating livelihoods and food security*. Routledge.
- Smith, H. (2013, 2013-08-06). Greece's food crisis: families face going hungry during summer shutdown. Retrieved from <http://www.theguardian.com/world/2013/aug/06/greece-food-crisis-summer-austerity>
- Somerville, C., Cohen, M., Pantanella, E., Stankus, A., & Lovatelli, A. (2014). Small-scale aquaponic food production: integrated fish and plant farming. *FAO Fisheries and Aquaculture Technical Paper.*, 1-262.
- Specht, K., Weith, T., Swoboda, K., & Siebert, R. (2016). Socially acceptable urban agriculture businesses. *Agronomy for Sustainable Development*, 36(1), 1-14. doi:10.1007/s13593-016-0355-0
- Stamouli, N. (2015). Crisis in Greece – The Numbers. Retrieved from <http://blogs.wsj.com/briefly/2015/01/20/crisis-in-greece-the-numbers/>

Tacon, A. G. (1990). A report prepared for the project Fisheries Development in Qinghai Province. *FISH FEED FORMULATION AND PRODUCTION*. Retrieved April 22, 2016, from <http://www.fao.org/3/contents/3e2fac62-0799-5350-a0ba-b12a6416d65f/U4173E00.htm>

Tokunaga, K., Tamaru, C., Ako, H., & Leung, P. (2015). Economics of small-scale commercial aquaponics in hawaii. *Journal of the World Aquaculture Society*, 46(1), 20-32. doi:10.1111/jwas.12173

TradingEconomics. (2016). Greece GDP. Retrieved from <http://www.tradingeconomics.com/greece/gdp>

Trading Economics (2016). Greece Youth Unemployment Rate 1998-2016. Retrieved from <http://www.tradingeconomics.com/greece/youth-unemployment-rate>

US Census Bureau, D. I. S. (2016). US Census Bureau Poverty main page. Retrieved from <https://www.census.gov/hhes/www/poverty/methods/definitions.html>

Wardlow, G. W., Johnson, D. M., Mueller, C. L., & Hilgenberg, C. E. (2002). Enhancing student interest in the agricultural sciences through aquaponics. *Journal of Natural Resources and Life Sciences Education*, 31, 55.

Weatherspoon, D., Oehmke, J., Dembele, A., & Weatherspoon, L. (2015). Fresh vegetable demand behaviour in an urban food desert. *Urban Studies*, 52(5), 960-979. doi:10.1177/0042098014529340

Wunderlich, G. S., Norwood, J. L., National Academies Press Free eBooks, National Research Council (U.S.). Panel to Review U.S. Department of Agriculture's Measurement of Food Insecurity and Hunger, & Ebrary Academic Complete. (2006;2005;). *Food insecurity and hunger in the united states: An assessment of the measure*. Washington, D.C: National Academies Press.

Zanolli, L. (2016). As Greece nears bankruptcy, residents self-organize food aid. Retrieved from <http://america.aljazeera.com/articles/2015/6/17/greece-nears-bankruptcy-residents-organize-food-aid.html>

5 Ways Factory Farming is Killing the Environment. (2016). Retrieved from <http://www.onegreenplanet.org/animalsandnature/factory-farming-is-killing-the-environment/>

Appendix

Appendix 1: Consent Script

We are a group of students from Worcester Polytechnic Institute in Massachusetts. We are conducting interviews with members of the AFS to inform our design of an aquaponics system on campus. We believe this kind of research will ultimately lead to a design that can accommodate the needs of the AFS community and that can be used as a useful educational tool.

Your participation in this interview is completely voluntary and you may withdraw at any time. This interview will take approximately forty five minutes. Please remember that your answers will remain confidential. No names or identifying information will appear in any of the project reports or publications unless consent is given.

This is a cooperative project between the AFS and WPI, and your participation is greatly appreciated. If interested, a copy of our results can be provided at the conclusion of the study.

Appendix 2: Education Interview

Objective:

- Understand what do individuals already know about aquaponic systems and what would be the most suitable way of catching their interest in the subject.
 - Be able to have a broad overview of how the educational curriculum works and what is the current reaching culture at the American Farming School works.
 - Understand how have other technical initiatives worked in the past, (such as Garden Based learning)
 - Understand other examples of technical applied education and what has their impact previously been in AFS.
 - Understand and find the different ways aquaponic systems would be useful to the lessons that are already being taught at AFS
 - Practical applications of aquaponics
 - Research
 - Lessons can include but are not limited to nitrification, sustainable developments, water chemistry, and biological cycles.
 - Understand in which areas aquaponic systems would be useful in terms of the AFS curriculum.
 - Entrepreneurship classes
 - STEM Classes
 - Environmental Classes
 - Sustainability Classes
- Find if students and teacher would be interested in being taught or teach with an aquaponic system as a learning model.
 - What are some of the concerns they might have of the system and what are ways we can efficiently address those concerns.
 - What are the main benefits students and teachers perceive in using this system as a way of teaching.
 - What are some of the desired features and parameters that students and teachers are interested on aquaponic systems to have.
 - What are the preferred methods student like to be taught with and teacher like to implement in their classes and projects, in order for an aquaponic system not to deviate from the current preferred methods.
 - What are some projects students have done that really have helped them understand the material that is given to them and how can we apply aquaponics in order to reach a similar outcome.
 - What are the specific aspect of those projects that really have made them stand up.
 - What are the specific aspect of those projects that really have made them stand up.

Question:

- How does the educational curriculum currently work?
- What are the current educational methods you implement in your lessons
 - What are some benefits of those methods?
 - What do you see as the drawbacks?
- Is there any particular project or activity you use to facilitate the learning method of students.
 - Can you give examples of any projects?
 - Any technical, hands on learning method?
- Can you describe your preferred teaching style?
 - Why do you chose this one, how much has it impacted your students?
- Would you consider the use of different technologies to assist your current teaching methods?
- What is your current opinion as an aquaponic system?
- What parameters would you consider important in order to implement such a system?
 - Aesthetics
 - Functionality
- What do you consider essential for a teaching tool to have in order to use it?
- Do you think that an aquaponic system could be implemented in your lessons?
- Do you have any concerns of how the system works?
- Is there any specific reason why you would use the system?

High School Teacher's:

Before further questions interviewer will give a brief explanation and examples of the ways other institutions have used aquaponics to teach lesson in chemistry, nitrification, plant biology and fish biology.

- What do you think about the idea of implementing the system to facilitate STEM concepts?
- Do you think that implementing the system will benefit your classes?
- Is there any class in particular you teach that you think the system will be suitable?
 - Chemistry of the water in the system
 - Plant biology
 - Fish biology
 - Microbial biology

Perrotis College Professors:

Before further questions interviewer will give a brief explanation and examples of how other institutions have applied aquaponic systems in their curriculums.

- What are some of the hands on learning experiences you do with your students?
 - what topics are your teaching?
 - why do it this hands on way instead of in the classroom
- What are other topics you wish to teach in a hands on environment?
- What research projects are you currently involved with and what are their objectives?
- Based on what you know about Aquaponics would you be interested in using it as a teaching tool and or research project?
 - what might you teach with it?
 - what projects could be done with it?
- Would your students be interested in learning about aquaponics?

Appendix 3: Administration Interview

Objective:

- 1) What are some of the motives behind developing an aquaponic system in their perspective and what are the resources available for the actual implementation of the system
- 2) Understand the willingness of departments such as facilities to maintain a system that its main purpose is being an educational tool.
- 3) Understand the needs of the administration and facilities in order to design a system they can support.
- 4) Have a broader view of the structure, logistics, safety, and budgetary concerns.
- 5) Benefits of having the aquaponics system as a “Selling Point”

Administration Questions

- What is your role at the American Farm School?
 - How to affect the educational programs at the school?
- How is a project or lab established or implemented at AFS?
- What do you know about aquaponics?
 - Explain if not
- Do you see having an aquaponics system can be beneficial for projects here at AFS?
 - Internally
 - Publically
 - Research
- What are your concerns with implementing the system?
 - Space
 - Safety
 - Resources
 - Maintenance

Appendix 4: Visual Aids



www.grobergreen.com



my-greenshelter.com

Appendix 5: List of interviewed instructors

Name	Description of the role
Antonia Kotoula	Biology Teacher (AFS)
Nikolaos Dodos	Entrepreneurship teacher (AFS)
Panagiota Chatzopovlov	Math Teacher (AFS) head of entrepreneurship club
Myrsini Manou Georgila	Student (AFS) President of Entrepreneurship club
Dimitrios Slavovdis	IT & Ag teacher (AFS)
Ioannis Mylonas	Ag Teacher (AFS)
Christos Vasilikiotis	Aquaponics Professor
Athanasios Gertsis	Environmental Systems Management professor
Konstantinos Rotsios	Associate Dean for Administration and Business Development
Evangelos Vergos	Associate Dean of Continuing Education & Extension Services and the Pathway Coordinator for Livestock Management
Ioannis Gatzolis	Department Head of horticulture
Barmpas Anastasios	Principal of Elementary School & Coordinator of Primary Education
Eva Kanellis	Dean of Student Services

