

October 2009

An Analysis and Comparison of Affordable and Ecological Short-Term Transportation Energy Solutions

Bryan Thomas Gleason
Worcester Polytechnic Institute

Follow this and additional works at: <https://digitalcommons.wpi.edu/iqp-all>

Repository Citation

Gleason, B. T. (2009). *An Analysis and Comparison of Affordable and Ecological Short-Term Transportation Energy Solutions*. Retrieved from <https://digitalcommons.wpi.edu/iqp-all/662>

This Unrestricted is brought to you for free and open access by the Interactive Qualifying Projects at Digital WPI. It has been accepted for inclusion in Interactive Qualifying Projects (All Years) by an authorized administrator of Digital WPI. For more information, please contact digitalwpi@wpi.edu.

An Analysis and Comparison of Affordable and Ecological Short-Term Transportation Energy Solutions

An Interactive Qualifying Project Report
submitted to the faculty of
WORCESTER POLYTECHNIC INSTITUTE
in partial fulfillment of the requirements for the
Degree of Bachelor of Sciences
By:

Bryan Gleason

Report Submitted to:
Prof. William Michalson

Abstract

In times when there is greater public concern with regard to energy consumption and the environment, significant efforts are being applied to the development of better vehicular technology, most notably hybrid electric and electric vehicles. If major improvement is to be expected in the near future, vehicles which show marked improvements upon our current standards of efficiency and emissions must be developed, and developed affordably. The goal of this IQP is to compare various vehicle technologies and determine a viable short term solution for further study.

Acknowledgements

I would like to thank my advisor, Professor William Michalson, for supporting this endeavor and for encouraging and/or threatening me when necessary. I would also like to thank my loved ones for listening to my rantings and pontifications, and for supporting my research efforts with thoughtful emails and the like.

Table of Contents

Table of Figures	iv
Table of Tables.....	vi
1: Introduction.....	1
2: Core Concepts.....	3
Electrical Energy Generation.....	3
Petroleum	7
Ethanol.....	7
3: Sources of Loss.....	8
4: Combating Loss.....	12
4.1 Hybrid Technologies.....	12
Hydraulic Hybrids.....	15
Parallel Hybrid Electric.....	18
Series Hybrid Electric	22
Plug-In Hybrid Electric.....	28
Electric Vehicles	28
5: Analysis of Vehicle Use.....	30
6: Analysis of Energy Consumption.....	44
7: Comparison of Technologies.....	47
7.1 Baseline	47
7.2 Environmental Considerations.....	50
7.3 Economic Comparison	52
8: Further Considerations.....	56
9: Conclusions.....	57
Bibliography	59

Table of Figures

Figure 2.1: Annual CO2 Emissions by Power Plant Type	4
Figure 2.2: Energy Flow and Loss in Electrical Energy Generation by Coal	5
Figure 2.3: CO2 Emissions from Fossil Fuel Combustion by Sector and Fuel Type	6
Figure 3.1: Air Flow Patterns Across a Passenger Vehicle	8
Figure 3.2: Diagram of a Disk Brake Assembly	9
Figure 3.3: Energy Flow and Loss in Typical Internal Combustion Engines	10
Figure 3.4: Thermal Efficiency Vs. Output of Various Types of Internal Combustion Engines	11
Figure 4.1.0: Block Diagram of an Electric-Flywheel Hybrid	13
Figure 4.1.1: Basic Diagram of a Hydraulic Hybrid Vehicle	15
Figure 4.1.2: Hydraulic Hybrid During Cruising Condition	16
Figure 4.1.3: Hydraulic Hybrid During Braking	17
Figure 4.1.4: Hydraulic Hybrid During Acceleration	17
Figure 4.1.5: Basic Diagram of a Parallel Hybrid Electric Vehicle	18
Figure 4.1.6: Parallel Hybrid at Start-Up	19
Figure 4.1.7: Parallel Hybrid During Heavy Load	19
Figure 4.1.8: Parallel Hybrid During Cruising Conditions	20
Figure 4.1.9: Parallel Hybrid During Braking	20
Figure 4.1.10: Parallel Hybrid at Rest	21
Figure 4.1.11: Basic Diagram of a Series Hybrid Electric Vehicle	22
Figure 4.1.12: Series Hybrid Schematic	23
Figure 4.1.13: Series Hybrid at Startup	24
Figure 4.1.14 Series Hybrid Under Cruising Conditions	24
Figure 4.1.15 Series Hybrid with Low Battery Charge, High Demand	25
Figure 4.1 16 Series Hybrid With High State of Battery Charge	25

Figure 4.1.17 Series Hybrid Under Heavy Load or Acceleration	26
Figure 4.1.18 Series Hybrid During Regenerative Braking with High SOC	26
Figure 4.1.19 Series Hybrid During Regenerative Braking with Low SOC	27
Figure 5.1 Fuel economy vs vehicle speed	30
Figure 5.2 UDDS Velocity vs. time	35
Figure 5.3 UDDS acceleration vs. time	35
Figure 5.4 UDDS acceleration vs. velocity	36
Figure 5.5 US06 velocity vs. time	38
Figure 5.6 US06 acceleration vs. time	38
Figure 5.75: US06 acceleration vs. velocity	39
Figure 5.8: HWFET velocity vs. time	41
Figure 5.9: HWFET acceleration vs. time	41
Figure 5.10: HWFET acceleration vs. velocity	42
Figure 7.3.1 Gasoline vs. Hybrid Repair cost by Model Year	53
Figure 7.3.2: Long Term Economic Comparison of Midsize Sedans	54

Table of Tables

Table 2.1: Power Plant Efficiency by type	5
Table 5.1 Real-world acceleration distribution	33
Table 5.2 Real-world velocity distribution	33
Table 5.3 UDDS acceleration distribution	33
Table 5.4 UDDS velocity distribution	33
Table 5.5 US06 acceleration distribution	37
Table 5.6 US06 velocity distribution	37
Table 5.7 HWFET acceleration distribution	40
Table 5.7 HWFET velocity distribution	40
Table 6.1.1: Average energy consumption per kilometer: urban and highway	45
Table 6.1.2: Baseline Energy Expenditure for Urban Driving	46
Table 6.1.3: Baseline Energy Expenditure for Highway Driving	46
Table 6.1.4: Combined City and Highway Baseline Energy Expenditure	46
Table 7.1.1: Comparison of various vehicles based on economic, ecological, and energy criteria	50
Table 7.2.1 Comparison of hybrids of varying DOH	52

1: Introduction

As stated in the Department of Transportation and National Highway Traffic Safety Administration's 2009 Corporate Average Fuel Economy report to the President, "the future of this country's economy, security, and environment are linked to one key challenge: energy." Energy is a key concern in our age, and one of the prime sources of energy consumption is transportation. If we are to reduce our energy usage and our impact on the environment, it is necessary to analyze the systems which consume energy and determine how to mitigate loss. Thus, we can move forward with a fuller awareness of how we use energy, how to be more efficient, more ecologically sound, and how we can do this as a whole.

Energy issues are prominent on the minds of scientists, politicians, and consumers alike, and the automotive industry has begun to respond. With the release of Honda's Insight in 2000, the prevalence of hybrid vehicles exploded. There are a variety of goals in developing new transportation technology. There are several important perspectives from which to consider the problem of energy usage by transportation. The first is the engineer's perspective. The engineer is primarily concerned with efficiency and minimizing energy consumption. This can manifest in a multitude of ways ranging from the streamlining of coal mining to reduce cost to the literal streamlining of a car to make it more aerodynamic. The second is the environmentalist's perspective. The environmentalist wishes to reduce the impact of vehicular usage on the environment. This entails curbing emissions, reducing oil consumption to prevent oil drilling, and the promotion of clean, renewable energy. Lastly, there is the consumer's perspective. The consumer desires many things but if history shows anything of the consumer, cost is paramount. This applies to the initial purchase cost of a vehicle, its maintenance costs, and its fuel costs. Certainly, there can be and is overlap of these perspectives, especially with recent heightened awareness of environmental issues. Nevertheless, it appears that one of the best ways to enact change in a system is to give people incentive to invest themselves in it. This requires the development of *affordable* technology. There is no doubt that we are currently capable of developing a vehicle of tremendous efficiency and marginal environmental impact, but the question remains of how we can develop an efficient, clean, and affordable vehicle that be integrated into our existing energy system.

This paper attempts to strike a balance between economy, efficiency, and ecology. While much research has been done in these respective categories, this tries to tie them together and view the

situation broadly. Firstly, an investigation into the production of energy itself is necessary so as to develop an understanding of the origins of energy sources. From there, traditional loss mechanisms are discussed so as to better understand what sorts of problems are being tackled. Once an understanding of these sources is developed, there is summarization of current attempts at fighting emission and cutting loss. Knowing these methods, their merits and shortcomings can be discussed. In section six, there is analysis of vehicle usage. Since certain technologies are better applied to specific application, discussion of vehicle usage is an important facet of this discussion. This leads directly into an analysis of energy consumption, based upon the understanding of how vehicles are being used. With all of this established, a comparison of different technologies can be performed.

In Section Two, we establish the concepts which we find to be central to this document. In Section Three, we expand on these concepts by discussing loss mechanisms in vehicles. In Section Four, we discuss way in which loss can be combated. In Section Five, we perform analyses of how vehicles are operated. In Section Six, we analyze how energy is consumed. In Section Seven, we begin to compare different technological solutions. In Section Eight, we discuss limitations of the study and recommendations for further study. Finally, in Section Nine, conclusions are stated.

2: Core Concepts

If we are to analyze the energy usage, efficiency, and ecology of vehicles, we must first understand how they use energy and where their energy comes from. Only in understanding the entire flow can we begin to see the impact of the choices we make. It is easy to overlook inefficiencies that occur before the fuel is even pumped into the vehicle, but without understanding the entire process, we have no grounds upon which to accurately compare vehicles of different technological paradigms. Thus, the concept of systemic energy usage must be established. Energy usage is generally thought of as how much energy is either lost or consumed by a given vehicle to travel a given distance. Systemic energy usage on the other hand takes into account all energy lost or consumed at every point from the drilling of oil to its combustion in the cylinder or the mining of coal to electrical generation to current in the motor.

In internal combustion engine vehicles, energy consumption is given in miles per gallon. This rating is estimated by the manufacturer and evaluated by the Environmental Protection Agency (EPA). This number tells us only the vehicle's rate of fuel consumption. This is problematic on a number of levels. One, the volumetric energy density of fuels differs. In other words, a gallon of diesel contains more energy than a gallon of gasoline and more than one and a half times the energy of a gallon of ethanol. Thus, three different engines with identical thermal efficiencies would get three very different mileage ratings based on the fuel they were fed. This metric does make sense from the standpoint of economy in the sense that it gives consumers a rough idea of how much they might spend on fuel. This metric does not however tell us anything of efficiency

Furthermore, the mile per gallon consumption metric is only applicable to gasoline or diesel-fueled vehicles. Though the efficiency of a given vehicle is important, our greatest concern is energy usage. High efficiency does result in lower energy consumption and thus certainly merits attention.

Electrical Energy Generation

Many of the proposed new technologies, especially Plug-In Hybrid Electric Vehicles (PHEVs) and Extended-Range Electric Vehicles (EERVs) depend on grid-derived electrical energy as their primary source of energy. Thus, to understand what sorts of changes in efficiency and ecology these vehicles will result in, we must understand our electrical energy generation system.

Nearly half (49.6%) of the electrical energy generated in the United States is generated at coal plants (Environmental Protection Agency, 2005). The next largest sources of electrical energy are nuclear (19.3%), gas (18.8%), and hydroelectric (6.5%). By far the largest producer of carbon dioxide and other greenhouse gas (GHG) emissions is coal plants, which produce 2.1 pounds of CO₂ per kilowatt-hour of electricity, on average (Energy Information Administration, 2003). Gas-fired power plants produce a comparable amount of CO₂ (2.0 lbs/kWh), but are less common. Nuclear and hydroelectric on the other hand, do not produce GHG emissions. Certainly there are objections to nuclear and hydroelectric means of electrical generation, but these objections are beyond the scope of this paper and will not be elaborated upon. A comparison of CO₂ emissions by power plant type can be seen below:

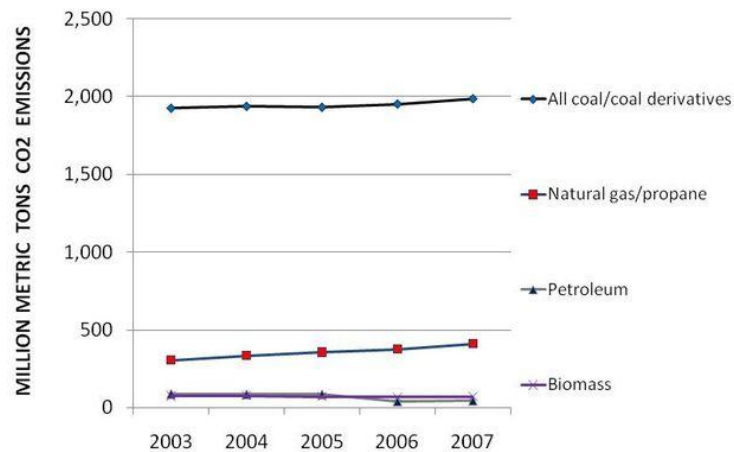

Figure 2.2: Annual CO₂ Emissions by Power Plant Type Source: <http://edis.ifas.ufl.edu/FE796>

The most important point to note from figure 2.1 is that while the CO₂ emissions per kWh of coal and gas-fired power plants are comparable, the overall production of CO₂ from coal-fired plants is higher due to the fact that there are many more coal-fired plants than gas-fired plants.

Fossil fuel-fired power plants in the United States are on average 33% efficient (Casten, 2008). This means that on average, only 33% of the energy contained in the fuel they use is converted into electrical energy. Though efforts are being made to improve power plant efficiency, this number has not changed since 1958 (Casten, 2008). Table 2.1 below shows rough efficiencies by power plant type. For sources of renewable energy, efficiency is important from the standpoint of cost effectiveness, but since their energy sources are free, renewable, and emission-less, their efficiency or lack thereof does not affect their environmental standing.

Power Plant Type	Efficiency (%)
Hard Coal	47
Brown Coal	45
Gas – STAG	58
Hydro	85
Wind	40
Solar Photo Voltaic	15
Thermal Solar	30
Nuclear	35

Table 2.1: Power Plant Efficiency by type Source: sealnet.org

Other considerations with regard to electrical power generation are the efficiency of fuel harvesting and the transmission of generated power. According to a study performed by Argonne National Laboratories, petroleum-based fuels had the lowest well-to-tank GHG emissions and lowest total energy consumption, with an efficiency of 81.7%. Conversely, hydrogen fuel, electricity, and cellulosic ethanol had the highest energy consumption and hydrogen and electricity had the highest rate of GHG emissions overall. This study takes into account the energy used and emissions created in the collection and delivery of fuel and the collection and delivery of the generated energy. Currently, average electrical transmission losses in the United States are 7.2% (U.S. Climate Change Technology Program, 2003). Figure 2.2 shows some of the loss mechanisms that exist in our power infrastructure, including plant losses and transmission losses. Some of these losses can be reduced with new electrical transmission technology, such as ultra-high voltage DC transmission.

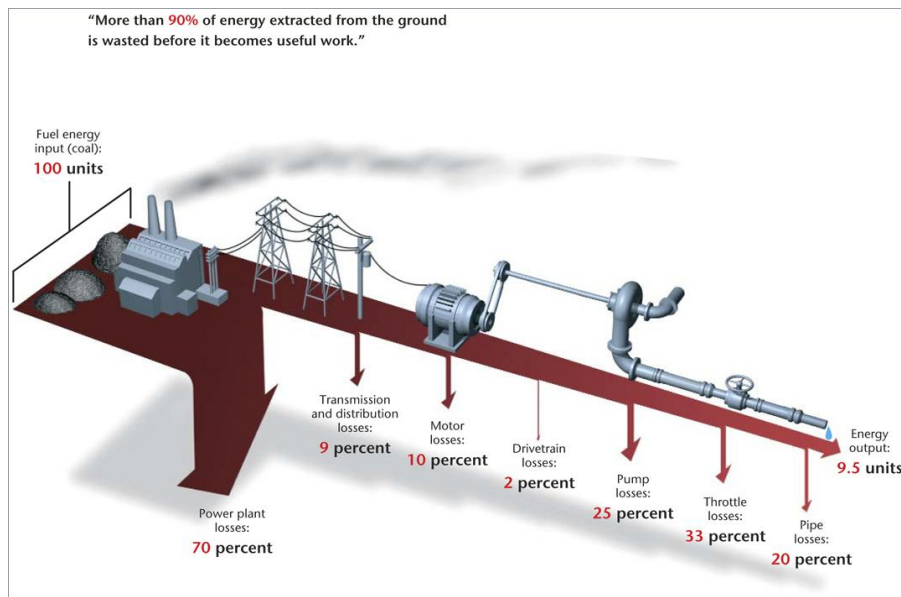

Figure 2.2: Energy Flow and Loss in Electrical Energy Generation by Coal Source: wbcSD.org

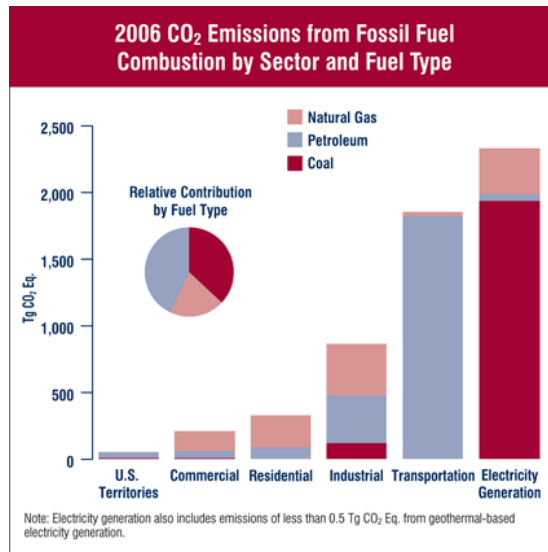

Figure 2.3: CO₂ Emissions from Fossil Fuel Combustion by Sector and Fuel Type Source: epa.gov

As can be seen in figure 2.3, by far the largest polluters in terms of GHG emissions are coal plants and their emissions represent a significant percentage of the total CO₂ emissions in the US. Given their prevalence and general inefficiency, they pose the most serious impediment to clean and efficient electrical energy, but they are currently the reigning standard. This does differ seriously by region. Some areas such as Indiana, Ohio, Kentucky, West Virginia, North Dakota, New Mexico, Utah, Wyoming, and Missouri derive the vast majority (over 85%) of their electricity from coal. Granted, when viewing energy usage at a system-wide level, these differences are less important than the average, but these differences also mean that the efficiency and ecology of electric-based technologies will vary regionally.

Furthermore, electrical generation companies plan to construct 154MW worth of new coal-fired power plants over the next 21 years (Morgan, 2006). This primarily because coal remains an inexpensive fuel source, whereas other fuels like gas have unpredictable and most likely inflating prices and renewable power sources are still considered a risk investment. The fear is that if we, due to our transportation system, become even more reliant on electrical power and the efficiency and rate of emission of our power generation system remains constant or even worsens, we could see anywhere from zero to negative gains in the efficiency and ecology of this system. This, in the long run, will be exceedingly costly. If the government implements restrictions on GHG emissions, certain regions could see their electric power rates increase substantially. Given that most studies performing cost-benefit analyses of HEVs and PHEVs assume a constant electric power cost, these studies could prove short-

sighted. In short, if the goal is to decrease energy usage and harmful emissions, it would be counterproductive to trade emissions and inefficiencies of one technology for that of another.

Petroleum Fuel

As was noted in the electrical energy generation section, there is no denying the efficiency of petroleum harvesting and its distillation into useable fuel. This means that a gasoline vehicle, viewed from a systemic perspective uses the equivalent energy of 1.137 gallons of gasoline for every gallon it actually burns. A simple way of looking at this is to take your car's mileage and divide it by 0.817. If your car gets 30 miles per gallon, that means it actually expends nearly 37 miles worth of energy. One does not feel this 7 mpg difference, but it affects the efficiency and ecology of the system as a whole. Overall, it can be said that the production and delivery of petroleum fuels is actually quite efficient, at least relative to other sources, namely electricity. This places the burden of efficiency and emission reduction on the vehicle itself. Electric vehicles on the other hand, can be very efficient when viewed as closed systems. The burden of efficiency and ecology for them lies before the energy even reaches them. This is a very important point because it creates a divide in how issues in the two technological realms are to be approached.

Ethanol

This study does not address the impact of ethanol. It is the opinion of the author that ethanol is not a valid transportation fuel alternative for the following reasons. The energy density of ethanol is 26.8 megajoules per kilogram. Given that the density of ethanol is 0.789 kilograms per liter, this results in a volumetric energy density of 21.15 megajoules per liter. The energy density of gasoline is 34.2 megajoules per liter. Thus, a car that gets 30 miles to the gallon on gasoline would get about 18.5 miles to the gallon on ethanol. The combustion of a gallon of gasoline results in the production of 19.4lbs of CO₂. The combustion of a gallon of ethanol results in the production of 12.57lbs of CO₂ (Wertheimer, 2009). Though this is much less, given the difference in fuel economy, travelling a mile on gasoline results in the production of 0.647 lbs of CO₂, whereas travelling a mile on ethanol results in the production of 0.679 lbs of CO₂. This is an unacceptable increase and thus ethanol will be ignored.

3: Sources of Loss

Regardless of how a vehicle is propelled, some loss mechanisms are common to all. One of these is drag. Losses due to drag are really frictional losses, losses of viscous friction caused by the vehicle moving through the air. Figure 3.1 shows how air flows around a car. The blue arrows represent non-turbulent (smooth) airflow and mean the air is taking a natural path. The red arrows represent turbulent airflow, such as behind the front wheel skirt. These turbulences are essentially areas of concentrated drag. Drag is proportional to the square of the velocity (Vawter, 2009), and thus is really more relevant at higher speeds, such as are found on highways. The shape of the vehicle and its frontal area also affect the amount of drag a vehicle can experience. All vehicles will experience drag to a certain degree.

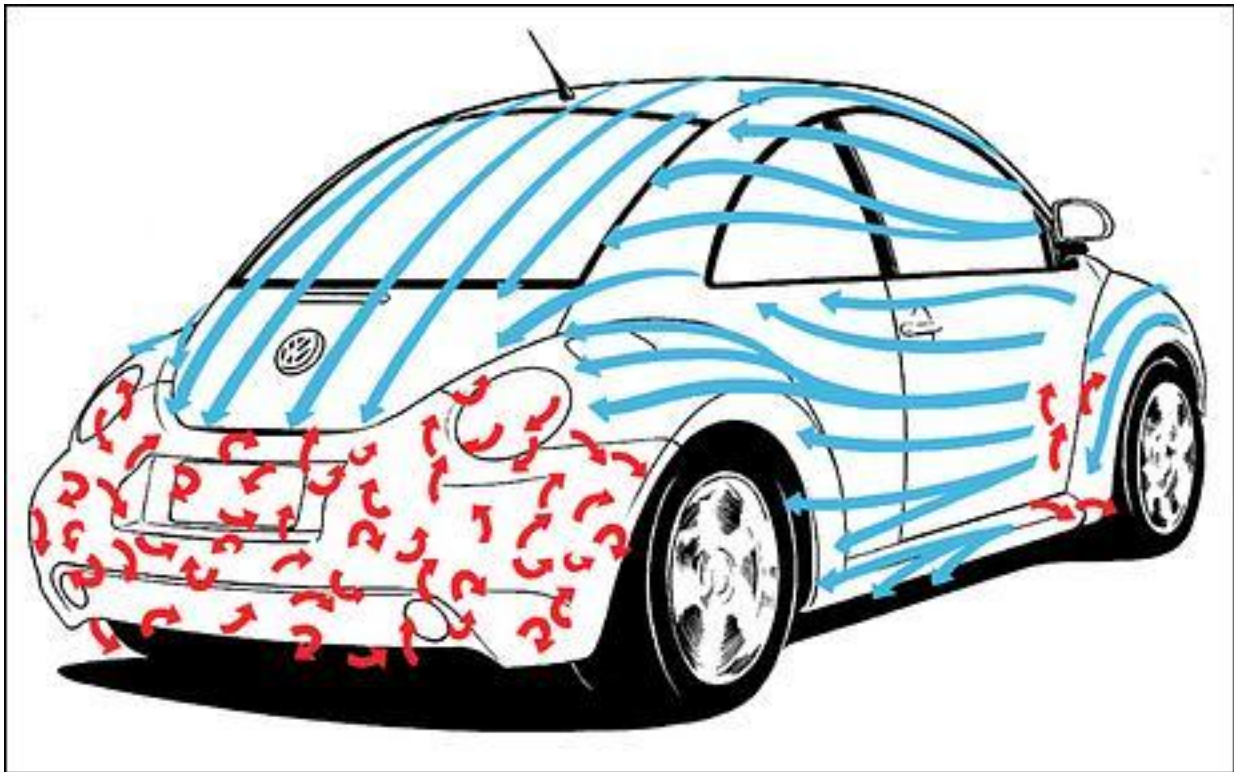

Figure 3.3: Air Flow Patterns Across a Passenger Vehicle Source: autospeed.com

To further generalize, friction is an unavoidable source of loss in vehicles and in any mechanical system. Friction occurs in bearings, engine cylinders, transmissions, between the tires and the road, and really in every mechanical system. These losses can be made to be relatively small. For instance, losses in a high quality gear box can be less than 5%. Some sources of friction are vehicle type specific. Some

traditional sources of frictional loss can be avoided by different types of drive train. Each propulsion mechanism has its costs and benefits, but all will result in some non-negligible amount of friction.

One of the largest sources of loss in vehicles is yet another form of friction: braking. When a car brakes it turns kinetic energy into heat via friction. The braking mechanism uses hydraulic fluid to push a piston with a brake pad against a (usually) steel brake rotor. Another pad contacts it on the other side, as seen in figure 3.2. The rotor tries to spin against the pads, which are pushed with hundreds of pounds of force, and gets hot as it slows down. This heat then dissipates into the environment, and is lost as far as the vehicle is concerned.

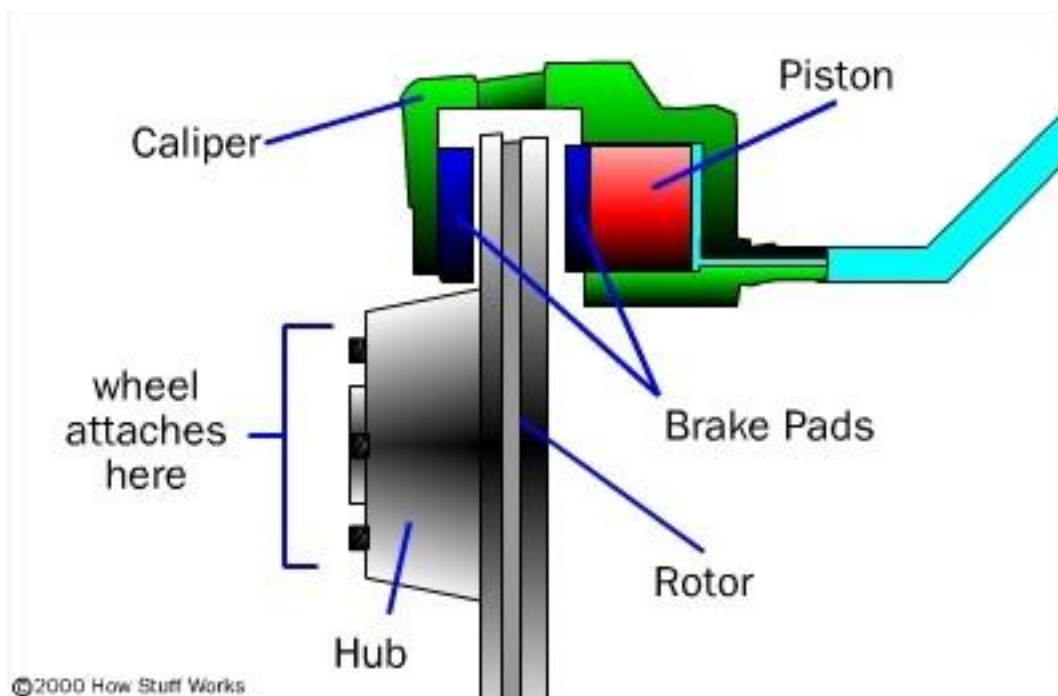

Figure 3.4: Diagram of a Disk Brake Assembly Source: howstuffworks.com

When a car is at speed, it has a certain momentum. Though left to its own devices it will eventually come to rest due to friction, drag, etc, in braking the car is taking the energy stored in its inertia and dissipating it into the surrounding environment as heat. It is possible to recover some of this energy, which is one of the advantages of hybrid vehicles, which will be discussed in the following section.

Another source of loss is in the transmission. Excellent gears can have efficiencies of 99%, but all transmissions are comprised of a collection of gears. Manual transmissions use friction-actuated clutches which via slippage allow engine and wheel speeds to be matched before the two are fully engaged. This often proves to be more efficient than the more common automatic transmission which

achieves the same goal using a torque converter. The torque converter uses a liquid (transmission fluid) as the coupling between the motor and the gearbox. Due to the fact that torque converters create friction whenever moving (as opposed to the clutch only creating friction when engaging) they have been less efficient than manual transmissions. In fact, this one point of inefficiency has resulted in higher mileage in the manual versions of vehicles than their automatic counterparts. In recent times, research has been put into improving the efficiency of automatic transmissions, often putting them on par with manual ones (Montoya).

There are inherent losses of ICE systems. The flow of energy in such a system can be observed in figure 4.0.1. Essentially, 70% of the energy that results in the combustion of fuel is lost as heat, either through the exhaust gases or through the coolant system (which transfers heat from the engine to the atmosphere). Some of the energy lost in exhaust gas is also the kinetic energy (velocity) of the gas itself. There is also a smaller degree of loss due to friction in the engine, such as the friction of the pistons against the cylinders.

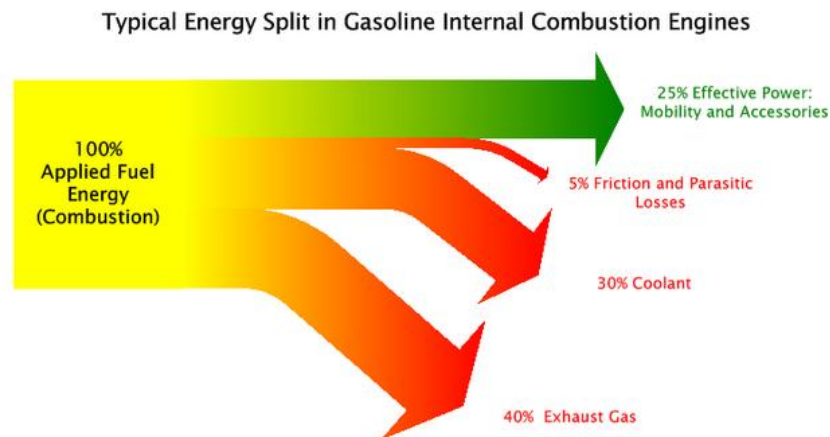

Figure 4.0.1: Energy Flow and Loss in Typical Internal Combustion Engines Source: greencarcongress.com

The primary source of loss from an ICE is thermal loss. These engines are governed by Carnot efficiency. The efficiency of a Carnot cycle engine is governed by the equation $\eta = 1 - \frac{T_c}{T_H}$ where η is the efficiency, T_c is the temperature of the available cold reservoir and T_H is the temperature of the available hot reservoir. What this means as applied here is that any heat lost from the engine system results in inefficiency. This we know, as heat leaving the system is energy that is not made to do work. This is the primary obstacle in the development of efficient internal combustion engines. The values in figure 4.0.1 give a good rough idea of the modes of loss in internal combustion engines, but as can be

observed in figure 4.0.2, the overall efficiency can vary significantly. Some engines are certainly more efficient, especially diesel engines. Figure 4.0.2 shows that automotive diesel engines are between 29% and 39% efficient whereas gasoline engines tend to be between 23% and 25% efficient. With more modern engine technology and the exploitation of different combustion cycles, high efficiencies can be achieved. For instance, the ICE in the Toyota Prius achieves a peak engine efficiency of approximately 37% by using an advanced combustion cycle called the Atkinson cycle (Duoba, 1999).

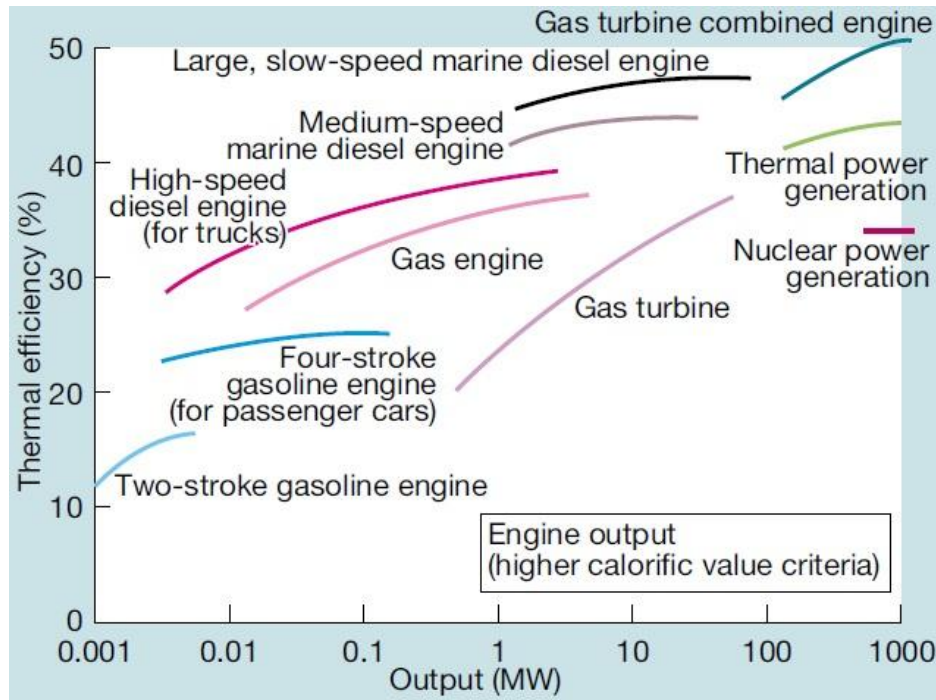

Figure 4.0.2: Thermal Efficiency Vs. Output of Various Types of Internal Combustion Engines
Source: mhi.co.jp

4: Combating Loss

There are three readily manipulated components to drag: drag coefficient, frontal area, and speed. The drag coefficient is dependent on the car's aerodynamics. Cars to which effort has been put into improving aerodynamics, such as the GM EV1, can have very low drag coefficients. The EV1 had a drag coefficient of 0.19 (Cogan, 2008), whereas the Hummer H2 has a drag coefficient of 0.57 (Certified Toyota Hybrids, 2009). This does not even take into account the disparity between the frontal areas of the two. The combination of these two variables is called the reference area. Essentially, if a coefficient of drag of 1 is a flat surface, the coefficient of drag multiplied by the frontal area gives the equivalent flat area, which is ideally much smaller than the actual frontal area due to the aerodynamics. In the name of improving efficiency, much research has been done in the area of aerodynamics. Cars such as the GM EV1, the Toyota Prius, and the Honda Insight all show serious aerodynamic design. As a result, these vehicles have low coefficients of drag, and thus take less energy to propel.

Internal combustion engines have the benefit of having a cheap and easy storage medium: the gas tank. Often made of stamped sheet metal and containing a non-pressurized liquid, the cost of a gas tank relative to a battery pack or a carbon fiber-wrapped pressurized tank is a pittance. Secondly, ICE vehicles have the benefit of a century of development and refinement. Though other vehicular technologies such as EVs and HEVs have existed just as long, they have never had the success that ICE vehicles have had

4.1: Hybrid Technologies

The idea of hybrid vehicles has become colloquial in recent years, but to analyze these technologies, we must first understand why hybridization is utilized. The underlying concept of hybridization is the idea that certain technologies are rather good at doing certain things and not so good at others. Thus, by delicately combining different types of technologies, we can exploit the favorable elements of various systems while minimizing their less desirable traits. In this sense, it is not unlike the breeding of animals. For instance, one of the most common goals of hybridization is to recover the energy lost when a vehicle brakes. In traditional combustion engine vehicles, there is no mechanism to recover this energy. Were it to be recoverable, the vehicle would be substantially more efficient and thus use less fuel. Here, hybridization techniques come into play. Regardless of the type of hybrid, all share the goal of recovering lost energy or minimizing loss to begin with. Attempts at hybridization have ranged from kinetic energy storing flywheels, such as the Chrysler Patriot to hydraulic

reservoirs to electric batteries or capacitors (Wakefield, 1998). The Patriot, a gas turbine flywheel electric hybrid used a flywheel as the energy storage and recollection device, and transferred that energy back to the wheels via a built-in electric motor/generator. Before battery technology had evolved to the degree it has today, means of temporary energy storage besides batteries made more sense. Figure 4.0.3 shows a block diagram of a hypothetical electric-flywheel hybrid. Here, a flywheel is used to capture energy during breaking and provide extra energy during acceleration and high loads, thus reducing the demand on the batteries, which at the time were lead acid.

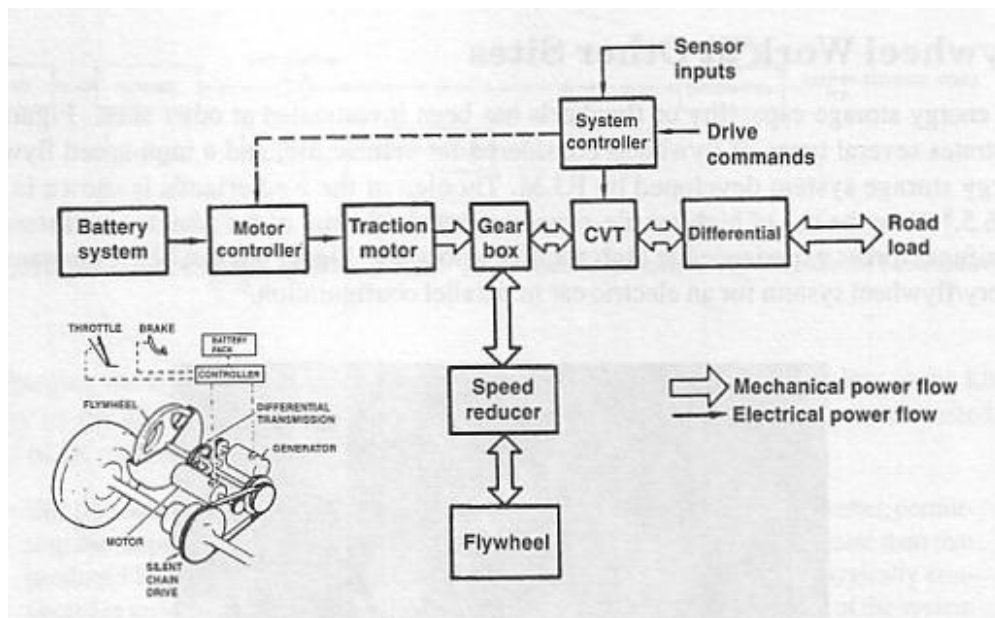

Figure 4.0.3 Block Diagram of an Electric-Flywheel Hybrid
 Source: History of the Electric Automobile: Hybrid Electric Vehicles

The trade-off in any hybrid is that the disparate elements of the drive train must be coupled in some way. Electric hybrids need a generator to convert mechanical energy from the engine to electrical energy and a motor to do the reverse. Each type of hybrid has relative advantages and disadvantages, making some better suited for specific applications than others.

The vast majority of hybrid vehicle concepts revolve around an ICE in some way or another. We have a well established petroleum harvesting, refinement, and distribution system. If we can exploit this established infrastructure while making systemic improvements, we can hasten the modernization of the transit system and save money, fuel, and the environment sooner. Also, most other vehicular

technologies face serious roadblocks in the realm of energy storage. Thus, by integrating themselves with ICE systems, they can obviate or at least reduce these energy storage issues.

There are a number of types of hybrids which will be discussed. Hydraulic hybridization refers to a system in which a hydraulic drive train is coupled to an ICE. There are two major types of electric hybrids. Parallel hybrids, which comprise all of the hybrid electric vehicles currently on the market, refer to a system in which an ICE and an electric motor operate in tandem. The series hybrid is a system in which an ICE drives a generator, which turns mechanical power into electrical power, which is then turned back into mechanical power by a motor. Plug-In Hybrid Electric vehicles (PHEVs) are hybrid electric vehicles which are designed to operate primarily on electric power and use an ICE only to restore charge to the battery if it drops below a certain threshold. Lastly, electric vehicles have no ICE; their only source of energy is a on board battery and they convert this stored energy to mechanical energy using a motor.

Hydraulic Hybrids

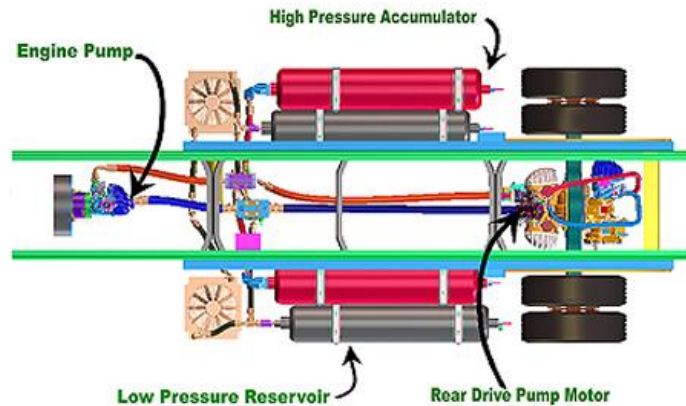

Figure 4.1.20: Basic Diagram of a Hydraulic Hybrid Vehicle Source: eaton.com

We will start with the hydraulic hybrid. This is a regenerative system in which the storage medium is a hydraulic accumulator instead of an electric storage device as in electric vehicles. A tremendous amount of energy is spent accelerating a vehicle from a standstill, and in urban driving, there tends to be a high degree of “stop and go” driving. By recollecting spent energy while braking, that energy is used to propel the vehicle from a stop, and the internal combustion engine takes over once the vehicle has attained driving speed. Using this system, fuel economy can be increased between 20% and 30% (Eaton Corporation, 2009). Currently, it is seeing the warmest reception in the commercial market. The hydraulic hybrid system has several advantages. It is easily integrated into existing fleet vehicles, it is inexpensive relative to electric hybridization, and it is easy to maintain. One disadvantage that has prevented its acceptance in the consumer market is that to attain high efficiencies it shuts off the engine at stops. This would mean that all peripherals (air conditioning, stereo, etc) would not function when the vehicle came to a stop. This actually increases its appeal in the commercial market, but makes it less viable as a consumer automotive platform. The other major disadvantage of the hydraulic system is that it is essentially useless for any sort of long-haul driving. There need to be periods of positive and negative acceleration to take advantage of the hydraulic assist, and in the case of long range or cross-country trucking, this advantage is lost. Hypothetically, hydraulic hybridization could be combined with electric hybridization wherein the storage medium would be a hydraulic accumulator which could be recharged via an electric motor during periods of relatively constant speed. This configuration does not exist yet and has the disadvantage of added complexity due

to the multitude of systems which would need to be integrated and maintained, but it is not to be discounted.

Let us examine how this system works. Figure 4.1.2 shows the system as it would be at startup and while driving normally. The hydraulic fluid is in a low pressure reservoir, which stores the fluid while it is not in active use. During this stage, the hydraulic system does not operate, and the engine provides all power for the vehicle.

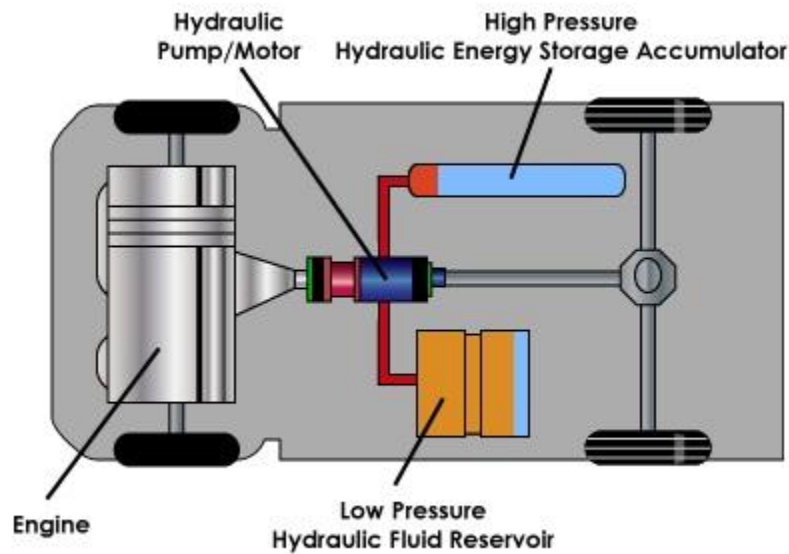

Figure 4.1.21: Hydraulic Hybrid During Cruising Condition Source: howstuffworks.com

Figure 4.1.3 shows what occurs when the vehicle stops. As a part of the stopping mechanism, the hydraulic pump/motor acts as a pump and pumps hydraulic fluid from the low pressure reservoir to the high pressure reservoir. The accumulation of this fluid under high pressure acts as an energy storage device. Also, the act of pumping the fluid requires work, which aids in the braking process. During this time, if the braking is prolonged and enough pressure is accumulated, the engine may even be shut off, as there is enough stored hydraulic energy to provide power until the engine is restarted.

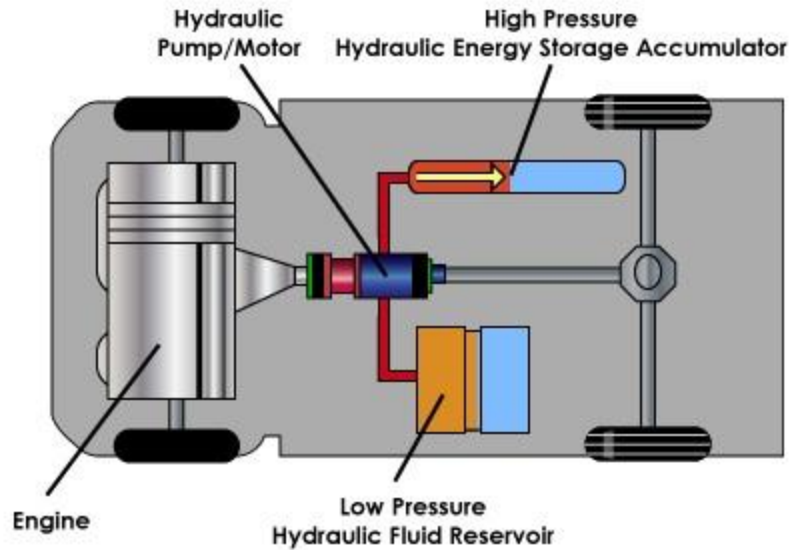

Figure 4.1.22: Hydraulic Hybrid During Braking source: howstuffworks.com

The last major condition, acceleration from standstill, is shown in figure 4.1.4. In this situation, the engine is not running, and all power is derived from the high pressure hydraulic fluid rushing through the hydraulic pump/motor, causing it to act like a motor and propelling the vehicle. As the vehicle attains cruising speed, the engine restarts and takes over powering the vehicle once again.

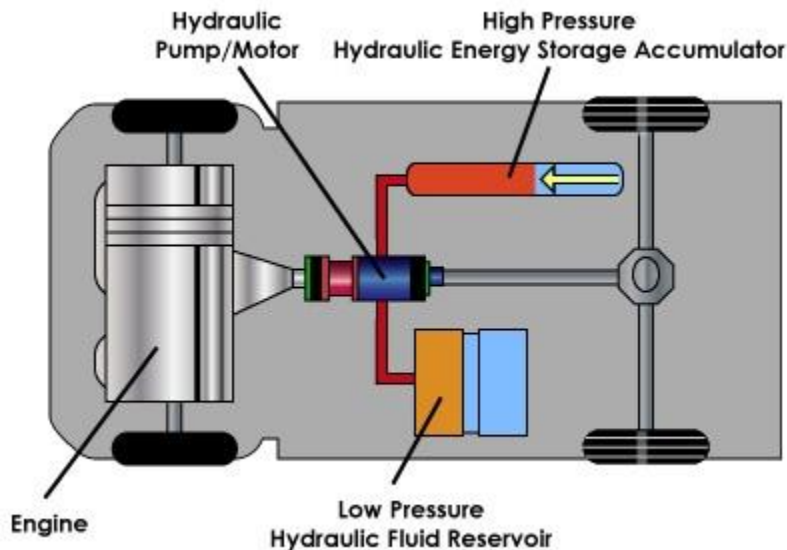

Figure 4.1.23: Hydraulic Hybrid During Acceleration source: howstuffworks.com

As stated earlier, it does not appear that there is any one solution to our transportation and energy problems. The hydraulic hybrid certainly has a niche to fill and has the distinct advantage of

being immediately deployable. It also does not rely on electrical energy storage devices, which gives it a serious advantage in terms of cost. This may well change in the coming decades, but seeing as how we need solutions now, hydraulic hybridization may be a very important stepping stone on the path to reducing energy expenditure.

The Modern (Parallel) Hybrid Electric

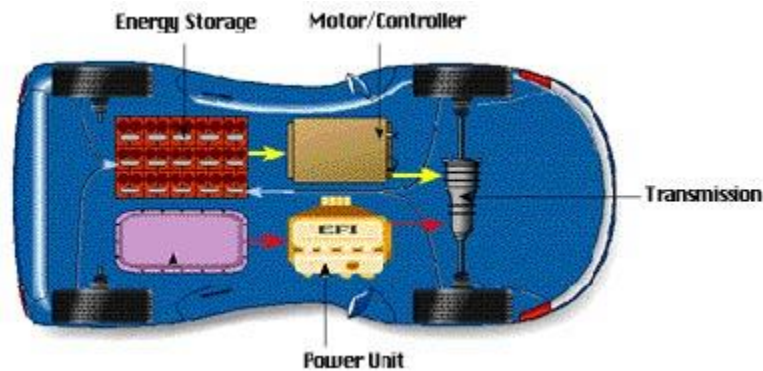

Figure 4.1.24: Basic Diagram of a Parallel Hybrid Electric Vehicle source: nrel.gov

Since the release of the Honda Insight in 2000 the prevalence and relevance of hybrid-electric vehicles has only increased. Though many manufacturers offer hybrids vehicles, Toyota's Prius has thus far been the most successful. All of the hybrid vehicles on the market today are parallel hybrids. This means that the electric motor and internal combustion engine can work separately or in tandem, but they both contribute directly to propelling the vehicle.

The parallel hybrid has several stages of operation, depending on conditions. To start the vehicle, power from the batteries is directed to the generator, which is run as a motor to start the ICE. Simultaneously, power from the batteries is also used to propel it, as can be seen in figure 4.1.6:

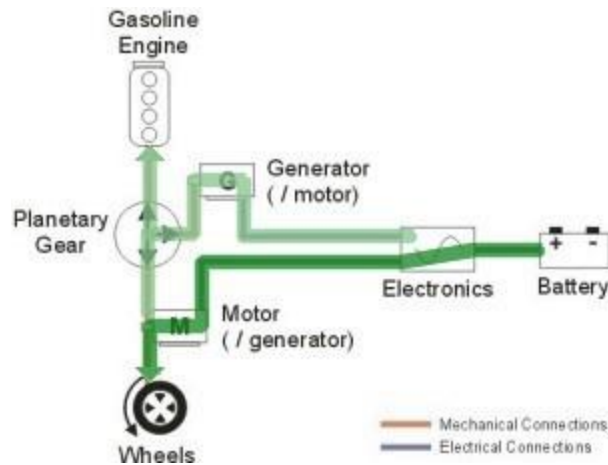

Figure 4.1.25: Parallel Hybrid at Start-Up source: zebu.uoregon.edu

Under heavy loads or high acceleration power from both the engine (via generator) and the batteries is diverted to the wheels. Thus, though neither the engine nor the generator have substantial power, together they can produce sufficient power for even high demand situations. Figure 4.1.7 shows the flow of energy under this condition:

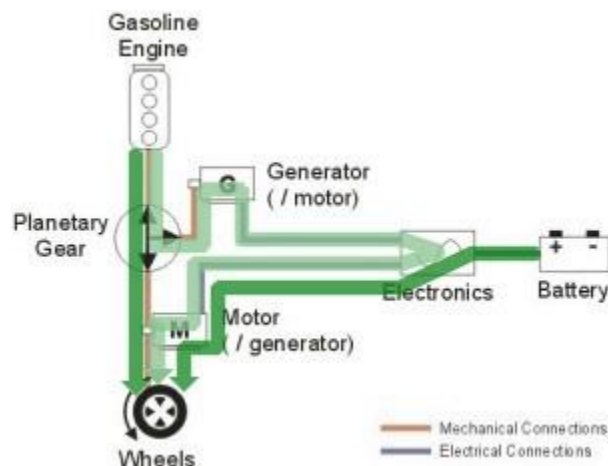

Figure 4.1.26: Parallel Hybrid During Heavy Load source: zebu.uoregon.edu

Once the vehicle has attained speed, both the motor and the engine provide motive power, but collectively they exceed the demand for moving the car, so excess power from the engine is diverted through the generator to the batteries, where charge is built and maintained, as can be seen in figure 4.1.8:

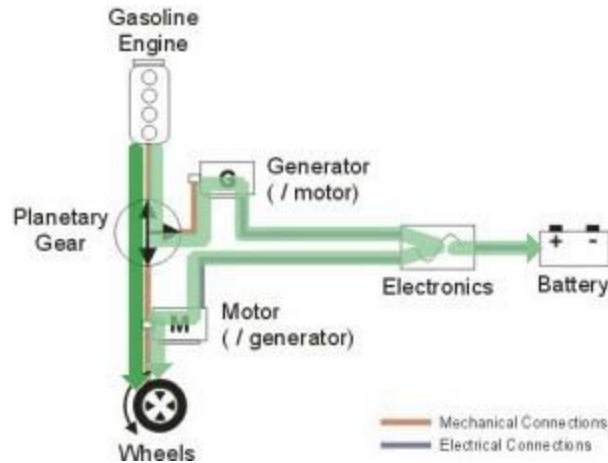

Figure 4.1.27: Parallel Hybrid During Cruising Conditions source: zebu.uoregon.edu

One place where the hybrid shines, as its hydraulic counterpart, is in braking. The parallel hybrid makes use of regenerative braking, using both its motor and its generator to convert the mechanical energy in the car into electrical energy. This, in turn, slows the car. The flow of energy under this condition can be observed in figure 4.1.9.

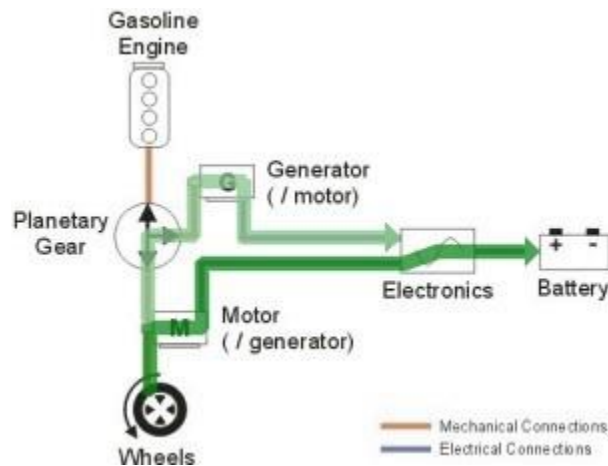

Figure 4.1.28: Parallel Hybrid During Braking source: zebu.uoregon.edu

Lastly, when the vehicle has come to a stop, the ICE shuts off to preserve fuel and the batteries provide power to peripherals (stereo, onboard electronics, etc). Through advanced vehicle control systems, the engine can quickly be restarted. Only if the battery charge is too low will the engine remain on while the vehicle is stopped. As figure 4.1.10 shows, there is no power flow in the drive train while the vehicle is stationary, as electric motors do not need any power if they are not actively doing

work. This is one major advantage of electric integration as, unlike conventional ICE vehicles, it means no fuel is spent at idle.

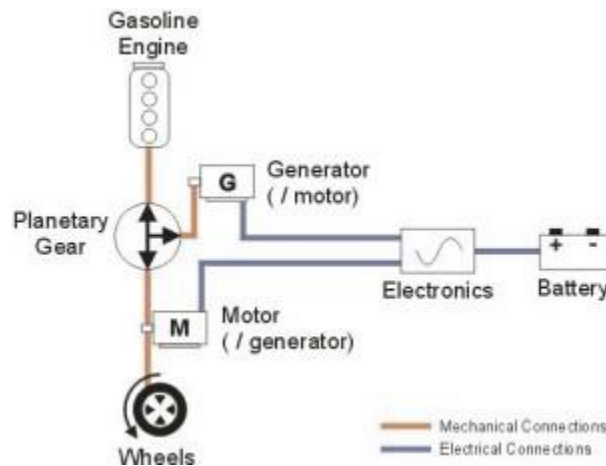

Figure 4.1.29: Parallel Hybrid at Rest source: zebu.uoregon.edu

There is no mass-market production example of the other type of hybrid, the series hybrid discussed earlier. Several auto manufacturers are currently developing series hybrid vehicles, referring to them as “extended-range electric vehicles”. As it stands, these vehicles are designed to run solely on battery power for short trips (generally projected to be <40mi), and engage an onboard engine/generator pair to recharge the batteries. Therefore, their title is accurate: they are intended to operate as electric vehicles for most trips, but an onboard generator provides power for trips of greater distance. This places these vehicles in somewhat of a nebulous category in which they straddle the line between hybrid and electric vehicles. It is as if they are both, and categorization is dependent on usage. In any case, they are not yet on the market.

With respect to fuel economy, the Toyota Prius is the best vehicle on the market (www.fueleconomy.gov, 2009). The only other hybrid ranked as highly fuel efficient is the Honda Civic Hybrid, in the compact car category. All other ranking vehicles are either traditional gasoline vehicles (with manual transmissions) or diesels. Yet, there are a multitude of hybrid vehicles produced by a variety of manufactures that do not necessarily boast higher fuel economies.

On the horizon, there are vehicles being developed by major auto manufactures which are projected to surpass the current best in class high-mileage vehicles. Primarily, these are (including but not limited to) the Chevrolet Volt (General Motors Corporation, 2008), Chrysler’s ENVI series (Chrysler LLC, 2009), and Mitsubishi’s i-MiEV (Mitsubishi Motors Corporation, 2008). Mitsubishi’s i-MiEV is

currently in production in Japan, and the Volt and ENVI series are projected to launch in 2010. Mitsubishi's i-MiEV is strictly electric, whereas the Chrysler and Chevy vehicles are "extended-range electric vehicles". Both are essentially series hybrids with larger battery capacities and the option to charge off of the grid. As of yet, none of these technologies are available in the United States, and it has yet to be seen how much these vehicles will cost. According to GM spokesman Dee Allen, though initially projected to cost about \$30,000, the Volt is "going to be closer to \$35,000." (WIRED, 2008). With such a high cost, even taking into account a government incentive, the Volt cannot be considered a mass market vehicle, and thus cannot be considered as a solution to the problem at hand. Furthermore, all extended-range electric vehicles will require substantial battery packs. For example, A123 Systems' Hymotion aftermarket battery system, which is marketed as a plug-in upgrade for Priuses, costs \$10,395 (A123 Systems, 2008). Given the \$22,000 MSRP of the 2009 Prius, an upgraded model would cost the consumer \$32,395 (Toyota Motor Sales, U.S.A., 2009). Granted, it can most likely be assumed that as production of these units increases, cost will decrease; this has yet to be seen and in the interim cost places these vehicles out of reach of most Americans.

The Series Hybrid

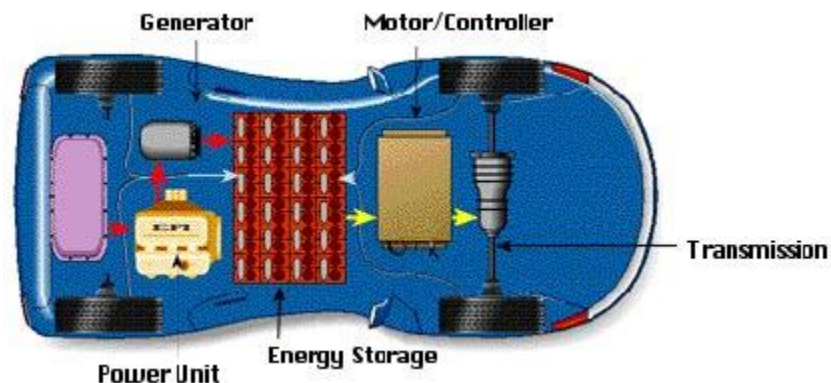

Figure 4.1.30: Basic Diagram of a Series Hybrid Electric Vehicle source: nrel.gov

One drawback to this configuration, like all electric hybrids, is that they necessitate an engine and a generator and/or motor. Though there may not be serious weight penalties involved, this does create added complexity and the necessity of sophisticated computer control. On the other hand, given that new cars tend to contain upwards of 50 microprocessors, this may not be a relevant concern (Turley, 2003). The series hybrid differs from the parallel hybrid in that the motor needs to be much

larger, as it provides all of the motive power. Additionally, the engine does not need to be as large, but the generator needs to be able to provide full power to the motor. It does not however need any sort of transmission or mechanical power distributor. An induction motor controller, if well designed, can provide efficient power regardless of rpm and vehicle speed without a traditional transmission.

Let us examine the operation of the series hybrid such that a discussion of the difference between parallel and series hybrids can be understood. The series hybrid is very much like the parallel hybrid with a few key distinctions. For one, there is no mechanical connection between the ICE and the wheels. Thus, there is no need for a mechanical power distributor (in the case of the Prius, a special continuously variable transmission or CVT) or transmission.

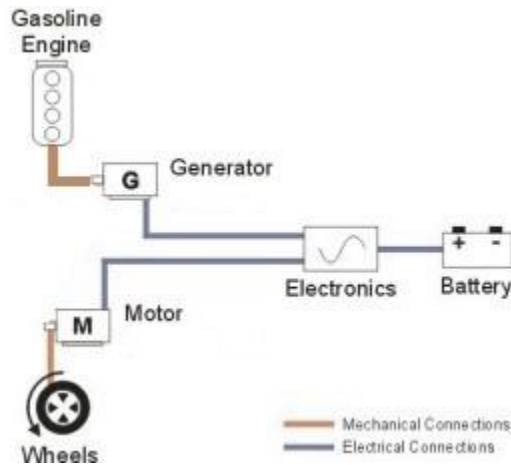

Figure 4.1.31: Series Hybrid Schematic source: zebu.uoregon.edu

At startup, power is derived from the batteries and using the generator as a motor, used as a starter to start the ICE. Figure 4.1.13 show the energy flow under this condition.

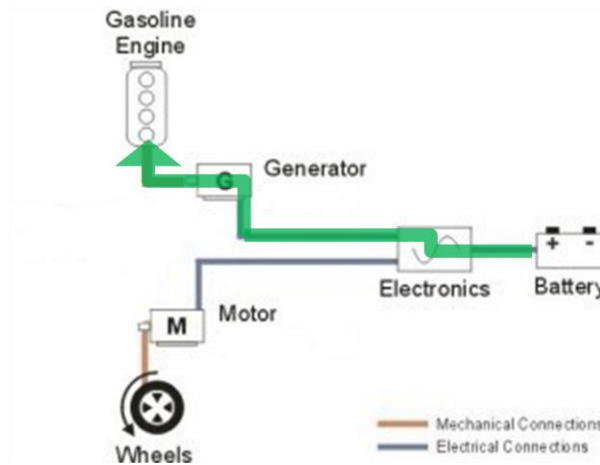

Figure 4.1.32: Series Hybrid at Startup source: zebu.uoregon.edu

If power demand is moderate and battery charge is less than full, the ICE will drive the motor directly through the electronics, and excess energy will be sent to the battery to charge it, as can be seen in figure 4.1.14.

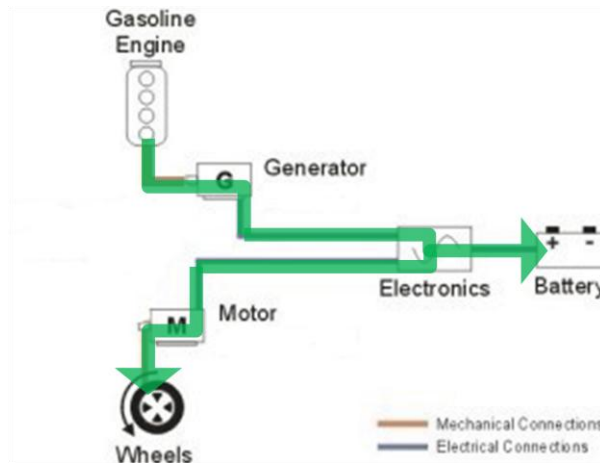

Figure 4.1.33 Series Hybrid Under Cruising Conditions source: zebu.uoregon.edu

There are two other primary drive conditions. Which of these conditions occurs is dependent on the state of the battery charge. If the power demand is high and the battery charge is low, the energy flow of figure 4.1.15 will be true. If the battery charge is high, the ICE can be shut off altogether, and all power can flow from the batteries, as in figure 4.1.16.

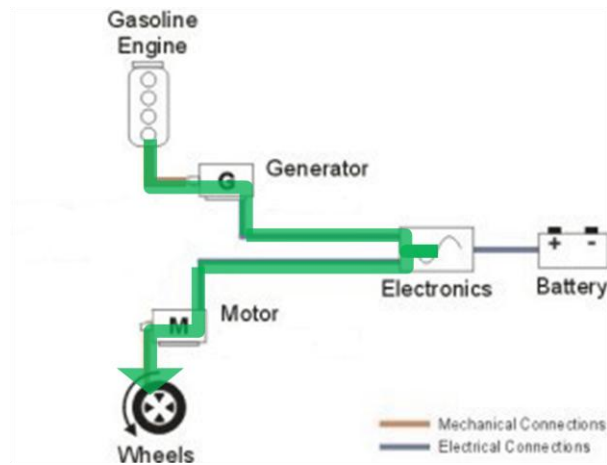

Figure 4.1.34 Series Hybrid with Low Battery Charge, High Demand Source: zebu.uoregon.edu

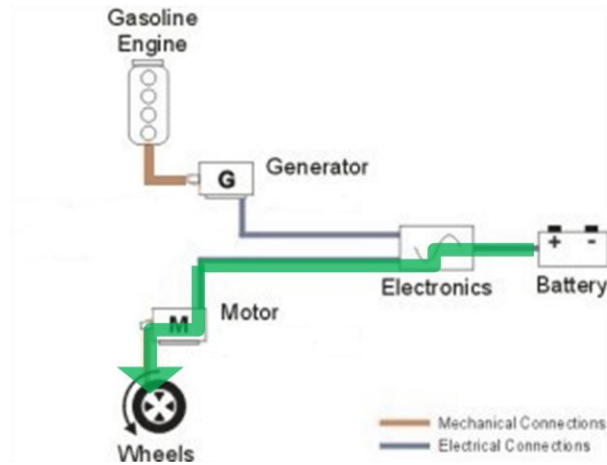

Figure 4.1.35 Series Hybrid With High State of Battery Charge Source: zebu.uoregon.edu

Under conditions of high acceleration or heavy load, if the battery has a reasonable state of charge, power may be derived both from the ICE and the batteries. The flow under this condition is shown in figure 4.1.17.

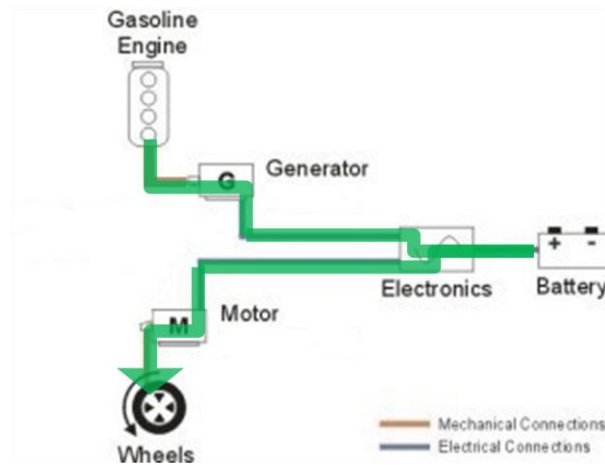

Figure 4.1.36 Series Hybrid Under Heavy Load or Acceleration Source: zebu.uoregon.edu

Lastly, like the parallel hybrid, the series hybrid is capable of regenerative braking. There are two possible conditions that can occur when the vehicle is braking. If the state of charge of the battery is relatively high, the ICE may be shut off temporarily and all power from braking will be routed through the motor (which is acting as a generator) to the charging system to the battery, as shown in figure 4.1.18. If the battery is in a low state of charge, the ICE will remain on, and all power from the regeneration and from the generator will be routed to the battery, as shown in figure 4.1.19.

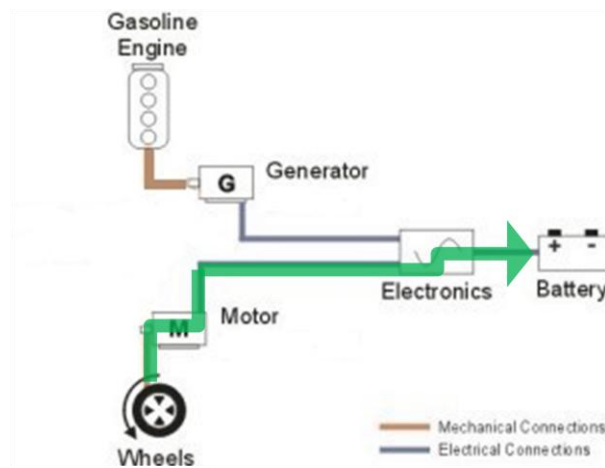

Figure 4.1.37 Series Hybrid During Regenerative Braking with High SOC Source: zebu.uoregon.edu

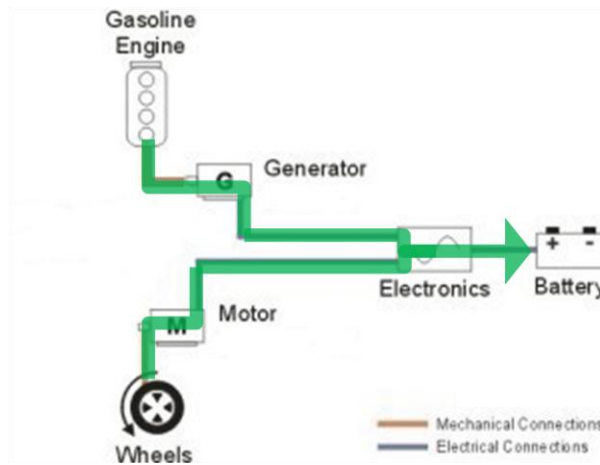

Figure 4.1 38 Series Hybrid During Regenerative Braking with Low SOC Source: zebu.uoregon.edu

Given that batteries are a major obstacle in the development of affordable vehicles, it is necessary to develop a system that minimizes the amount necessary. A series hybrid would only need enough batteries to provide a power buffer and temporary storage medium, not unlike the hydraulic hybrid. Unlike the hydraulic hybrid, the series hybrid is able to charge and discharge its storage medium even under continuous travel conditions, such as highway driving. If the generator being run off of a small motor were to be capable of powering the vehicle under all but peak power conditions, under normal operation the generator would be able to simultaneously be able to power the vehicle and charge the batteries. Under acceleration, the motor would derive power from both the generator and the batteries. The series hybrid would, like its parallel counterpart, utilize regenerative braking.

One distinct advantage of the series hybrid over the parallel hybrid is that the engine can be run at a constant rpm. By doing this and supplying a constant load which has been optimized to the engine, the engine can be run at its peak efficiency point at all times. No other vehicle type that currently exists is able to continually derive energy from its fuel source at peak efficiency. Since all vehicles use energy derived from some sort of fuel, the ability to extract energy from that fuel most efficiently would have a tremendous impact. Not only does this increase overall efficiency, but increased efficiency in turn reduces systemic vehicular emissions because reduced energy expenditure for a given unit of distance travelled results in reduced emissions. Modern engines, including that of the Prius are designed to develop power over a wide range of speeds. An engine designed to be run at a single point under constant conditions could be much more efficient than other engines.

Even with rather conservative calculations, it appears that a series hybrid would expend far less energy per unit distance. Given that it requires batteries only to buffer the energy from the generator,

provide boost in demanding situations, and provide temporary storage, the amount of batteries necessary would be equal to that of a stock hybrid.

Plug-In Hybrid Electric Vehicles

On the horizon, there are vehicles being developed by major auto manufactures which are projected to surpass the current best in class high-mileage vehicles. Primarily, these are (including but not limited to) the Chevrolet Volt (General Motors Corporation, 2008) and Chrysler's ENVI series (Chrysler LLC, 2009). The Volt and ENVI series are projected to launch in 2010. These vehicles are "extended-range electric vehicles". Both are essentially hybrids with larger battery capacities and the option to charge off of the grid. It is unknown what architecture (series or parallel) they will be utilizing). As of yet, none of these technologies are available in the United States, and it has yet to be seen how much these vehicles will cost. According to GM spokesman Dee Allen, though initially projected to cost about \$30,000, the volt is "going to be closer to \$35,000." (WIRED, 2008). With such a high cost, even taking into account a government incentive, the Volt cannot be considered a mass market vehicle, and thus cannot be considered as a solution to the problem at hand. Furthermore, all extended-range electric vehicles will require substantial battery packs. For example, A123 Systems' Hymotion aftermarket battery system, which is marketed as a plug-in upgrade for Priuses, costs \$10,395 (A123 Systems, 2008). Given the \$22,000 MSRP of the 2009 Prius, an upgraded model would cost the consumer \$32,395 (Toyota Motor Sales, U.S.A., 2009). Granted, it can most likely be assumed that as production of these units increases, cost will decrease; this has yet to be seen and in the interim cost places these vehicles out of reach of most Americans.

A cost-benefit analysis of PHEVs by the National Renewable Energy Laboratory confirms these fears. If we can assume that a vehicle sans drive train costs approximately \$17,390, we can then estimate the total projected cost of PHEVs with various degrees of hybridization. The study reports that PHEVs will cost incrementally more than a given conventional ICE vehicle, proportional to the degree of hybridization. This is largely due to the increase in battery capacity as the all-electric range is increased.

Electric Vehicles

The final category is the pure electric vehicle. Perhaps the most discussed example of this is the now defunct GM EV-1.

Electric vehicles contain a large number of batteries that are the sole energy storage device in the vehicle. Power tends to come from the local power grid, where it is rectified and used to recharge the batteries. EVs are powered by electric motors, be they DC, AC induction, or any other type. There seems to be a widespread common misconception that electric vehicles are inherently “greener” than their gasoline-powered counterparts. The truth is however that a vehicle is only as clean and efficient as its power source. When analyzing internal combustion engine cars this is made easier by the fact that the energy conversion occurs in the vehicle itself. When examining electric vehicles, one must trace the power back to its source. With the exception of those who own electric vehicles and recharge them exclusively with power from solar, wind, or other renewable energy sources, electrical energy comes from the combustion of fuel. As previously established, this conversion is 33% efficient on average. Certainly in some locations there are modern power plants with higher efficiency, but these are the exception. This efficiency limits the efficiency of electric vehicles. Even if an electric vehicle were capable of achieving 100% efficiency, it would still only be as efficient as the power it received. Furthermore, this is not the case. Aside from power plant efficiency, there are transmission losses (losses in transmitting power from the power plant to a given home), charger losses, inverter losses, storage losses, heat, friction, and everything else. Granted, some of these losses are very small, but collectively, they represent the systemic efficiency of the vehicle. Vehicles like the Tesla Roadster are highly efficient, but as will be shown later, the increase in cost by no means justifies the minor efficiency and emission improvements EVs result in.

5: Analysis of Vehicle Use

To properly judge vehicles on their energy consumption, we must first analyze how vehicles are used. It is well understood that driving patterns affect a vehicle's energy consumption. Therefore, it is crucial to understand *how* people drive so as to understand how energy is consumed. Since the rates of energy consumption or loss vary based on the forces on a vehicle at a given time, it is necessary to create a model of "average" driving patterns. A number of driving pattern studies have been done and are used as foundations of driving models. Using these models, researchers are able to predict the impact of new vehicular technologies. These models are used to compare things like relative energy consumption, affordability, emissions, and more. These models are very effective at assessing the impact of a given vehicle or type of vehicle, and have proven rather accurate when compared to experimental data (Glinksy, Hieronymus, Kelly, & Zolot, 2001).

Driving style can be quantified by two factors: acceleration and velocity. Someone who accelerates and brakes "hard" will expend more energy as they will be using more force over a given distance. Conversely, someone who uses a light touch will tend to expend less energy in their driving. Maintenance of constant speed generally means less energy usage as there is little to no acceleration involved. This ceases to be true at high speeds as the forces from drag becomes significantly higher towards the upper threshold of highway speed, as can be seen in figure 5.1.

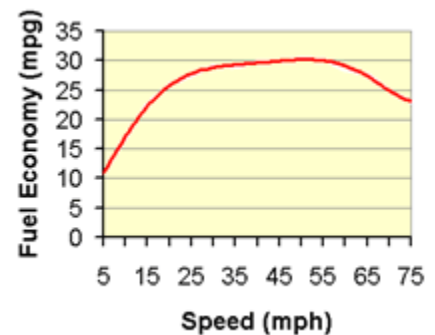

Figure 5.6 Fuel economy vs vehicle speed
Source: fuelconomy.gov

In short, there is a human component to analysis of vehicular energy expenditure. Widespread change in driving habits towards more efficient ones, obedience to traffic laws, and preference towards smaller and more efficient cars would all dramatically affect the overall efficiency of our automotive system, but these are social issues that are simply beyond the scope of this study. What can be done however is to analyze the habits that can be quantified, to try to understand them, and to try to optimize vehicles to be more efficient despite the habits of their pilots.

Quantification of driving habits is complex and requires large amounts of data to provide statistically significant results. Given the scope of this inquiry, the findings of other researchers have been utilized in creating a driving model. It is necessary to establish a least a rough picture of how

people use their cars. Though the model used here may not hold true universally; it may be impossible to do so. The limitations of this model will be discussed in a later section.

Before looking at data, some important points and limitations should be illuminated. Some studies, such as that of A. Simpson, rely heavily on the 1995 National Personal Transportation Survey. This survey contains information about the type, frequency, and length of trips taken in cars. Using this data, a number of conclusions can be drawn about the energy capacity of a vehicle. As applied to PHEVs such as Simpson does this can be helpful in determining what sort of energy storage system a primarily electric vehicle ought to have. Thus, if one's goal is to develop a vehicle that is primarily electric with an ICE/generator backup, one can roughly determine the point at which a generator ought to switch on and restore charge to a battery pack. This point should be chosen such that the majority of trips taken are able to be taken solely on electric power and the ICE/generator only comes into play when that length is exceeded; that is, a small percentage of the time (Chrysler Group LLC, 2009).

Other studies, such as that of André et al focus on the specifics of vehicular usage under various traffic conditions: stop time, frequency of stop, average acceleration, average velocity, etc. One important conclusion that can be drawn from this study in particular is that the vehicles usage, its average magnitude of velocity and acceleration, differ based on vehicle characteristics. That is, persons driving higher powered cars tend to accelerate hard and drive faster, regardless of conditions as noted by André, et al in their study of real-world European driving cycles (Andre, Joumard, Vidon, Tassel, & Perret, 2005). This is an interesting point that is perhaps better studied by psychologists than engineers, but nevertheless is a factor to consider.

The EPA has utilized several standardized driving cycles used for testing of vehicles. The most common and still utilized is the Urban Dynamometer Driving Schedule (UDDS). Developed in 1975 for the EPA, it is intended to simulate urban driving for reasons of mileage and emission estimates. The other is the HWFET, which is used to simulate highway driving conditions. Starting in 2008, the EPA added three tests to its mileage rating system. The first, the US06, additionally tests cars at high speeds and under heavy acceleration. The second tests vehicles under hot conditions with their air conditioners running. The third tests vehicles when running with cold external temperature. The second is particularly interesting as air conditioning units present large loads to the alternator in ICE cars and to the generators or batteries in HEVs. Thus, the addition of this test procedure attempts to accurately reflect the decrease in fuel economy resulting from air conditioner use. Given that in many locations, it

is necessary to run the air conditioner at least part of the year, its usage affects the overall average fuel economy. These drive cycles are shown below:

It is necessary to analyze driving patterns and real world driving patterns so as to better understand how cars are used and thus be able to optimize them for these patterns of usage. In the United States, vehicle mileage estimates are performed by the EPA using a variety of driving patterns. The combination of these estimates results in the mileage estimate for a given vehicle. The majority of research concerning the creation of real world driving patterns has been conducted outside of the United States, so before comparison limitations must be discussed.

In small European countries, there is significantly less terrain and traffic pattern variation than in the U.S. This implies two things. One, driving cycles constructed for these countries may not be so much inaccurate as much as too specific. They very well may be representative of driving patterns of certain regions of the U.S, but given the relative vastness and diversity of the U.S., it may be inadvisable to directly compare these real world driving studies to our own driving pattern data. This being said, our current models may be inadequate given regional differences. Simply put, a vehicle designed to operate on low congestion open roads in Iowa would likely not fare well in the highway gridlock of Los Angeles.

Taking these thoughts into consideration comparison of existing driving cycles can be conducted with the aim of deriving a driving pattern model with which to estimate vehicle usage. We will examine a real world driving study conducted in an urban environment in Sweden and the U.S. EPA's UDDS, HWFET, and US06 driving patterns.

Eva Ericsson

Level of Acceleration (m/s ²)	Percent Time
< -2.5	0.14
-2.5 to -1.5	1.54
-1.5 to -1	3.12
-1 to -0.5	6.81
-0.5 to 0	35.8
0 to 0.5	39.3
0.5 to 1	9.8
1 to 1.5	2.7
1.5 to 2.5	0.65
> 2.5	0.056

Table 5.1 Real-world acceleration distribution

Vehicle Velocity (kph)	Percent Time
0 to 15	12.0
15 to 30	19.8
30 to 50	39.6
50 to 70	27.3
70 to 90	0
90 to 110	0
110 to 130	0

Table 5.2 Real-world velocity distribution

UDDS

Level of Acceleration (m/s ²)	Percent Time
< -2.5	0
-2.5 to -1.5	0
-1.5 to -1	8.69
-1 to -0.5	5.26
-0.5 to 0	33.4
0 to 0.5	38.2
0.5 to 1	7.67
1 to 1.5	6.43
1.5 to 2.5	0
> 2.5	0

Table 5.3 UDDS acceleration distribution

Vehicle Velocity (kph)	Percent Time
0 to 15	29.0
15 to 30	13.7
30 to 50	42.0
50 to 70	7.37
70 to 90	6.64
90 to 110	1.09
110 to 130	0

Table 5.4 UDDS velocity distribution

First, we compare the UDDS driving schedule, used by the EPA to model American urban driving and a real world study of urban driving conducted by Eva Ericsson in Sweden. Looking at the acceleration tables (5.1 and 5.3), we first note that the UDDS schedule does not include accelerations of less than -1.5 m/s^2 or greater than 1.5 m/s^2 , where as the Swedish study does. This can be seen even more clearly in the graphical representation, figure 5.3. Though the collective percent time spent in these accelerations is relatively small (2.386%), this does represent a discrepancy between the studies.

The EPA seems to have recognized this discrepancy, and in 2008 instituted the US06 high acceleration aggressive driving schedule (referred to as “Supplemental FTP”). This pattern is more extreme, covering high speeds, aggressive braking, and aggressive acceleration. It will be reviewed next.

The UDDS schedule is intended to represent “average” urban driving conditions, and it may have been felt that acceleration of those magnitudes represented “unusual” driving conditions. Also, it is entirely possible that urban driving habits in Sweden are different from those in the United States. There are also minor differences between the percent times spent between -0.5 m/s^2 and -1.5 m/s^2 and between 0.5 m/s^2 and 1.5 m/s^2 . This can at least partially be attributed to the aforementioned difference in the higher magnitude accelerations. Both show that the vast majority of time is spent between -0.5 and 0.5 m/s^2 , meaning that the majority of the time is spent between very light braking, coasting, and mild acceleration. This can be seen well in figure 5.3, which graphs acceleration versus time for the UDDS schedule. Next, we examine the velocity tables (5.2 and 5.4). Here, the differences are more notable. We see that in the UDDS schedule, there is significantly more time spent between 0 and 15 kph. This can best be observed in figure 5.5, which plots acceleration versus velocity. This may be due to differing traffic patterns, and may imply that cars in the U.S. spend more time at idle. Also, the UDDS driving schedule includes some time in the 70 to 110 kph range. This discrepancy is more than likely due to differences in speed limits between the two countries.

These differences imply some interesting conclusions. Basically, locale can affect how vehicles are used, and as will be shown in section 6, how energy is used. Long idle times, high velocities, and high accelerations all contribute to higher energy consumption.

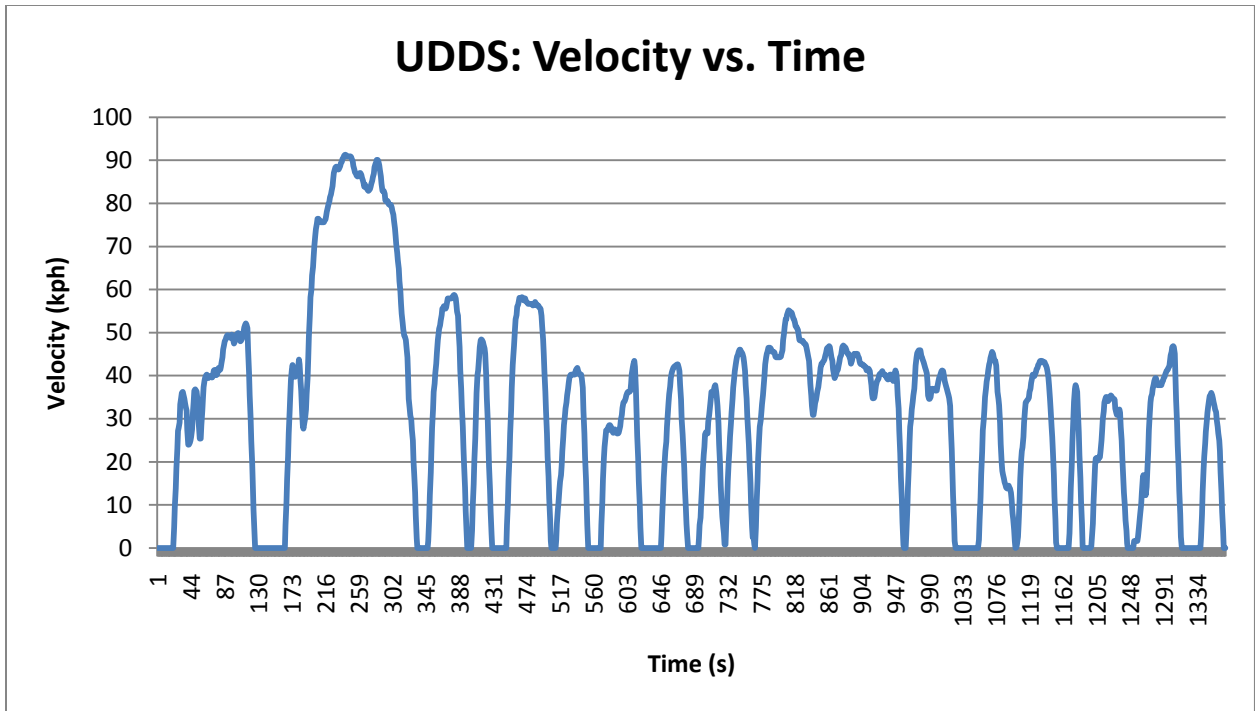

Figure 5.7 UDDS Velocity vs. time

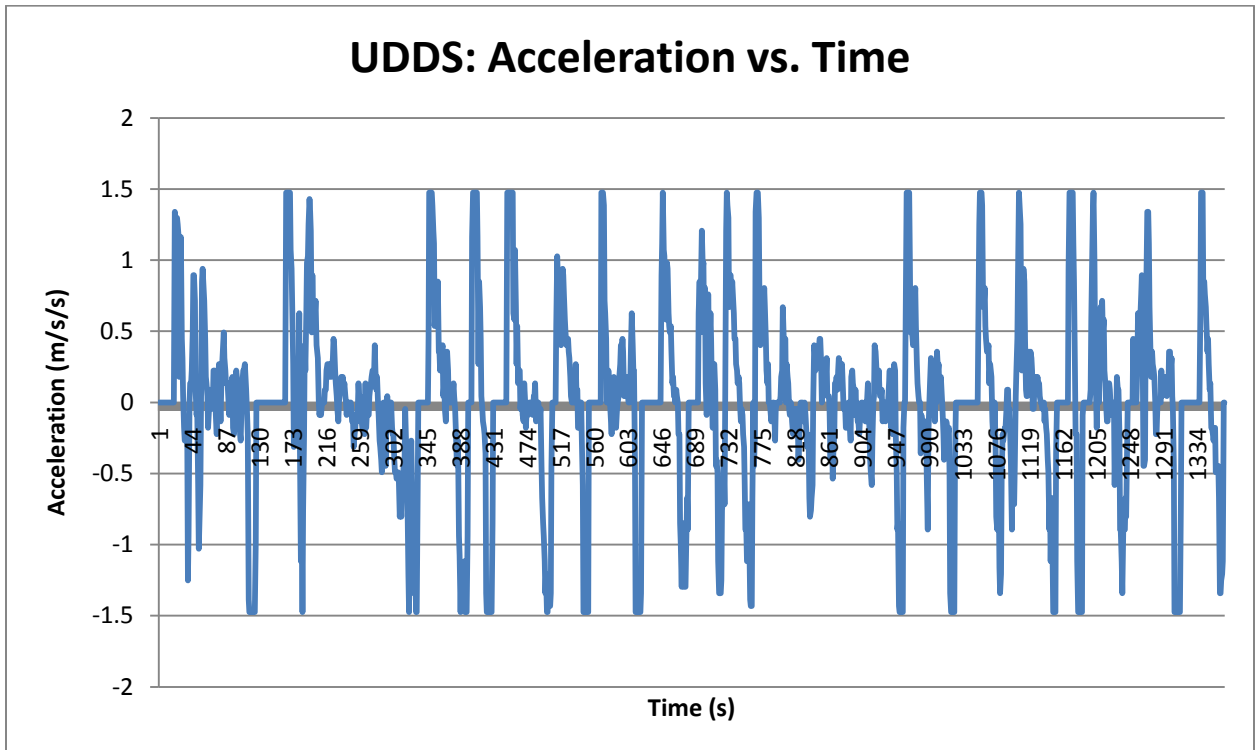

Figure 5.8 UDDS acceleration vs. time

UDDS: Rates of Acceleration at Various Speeds

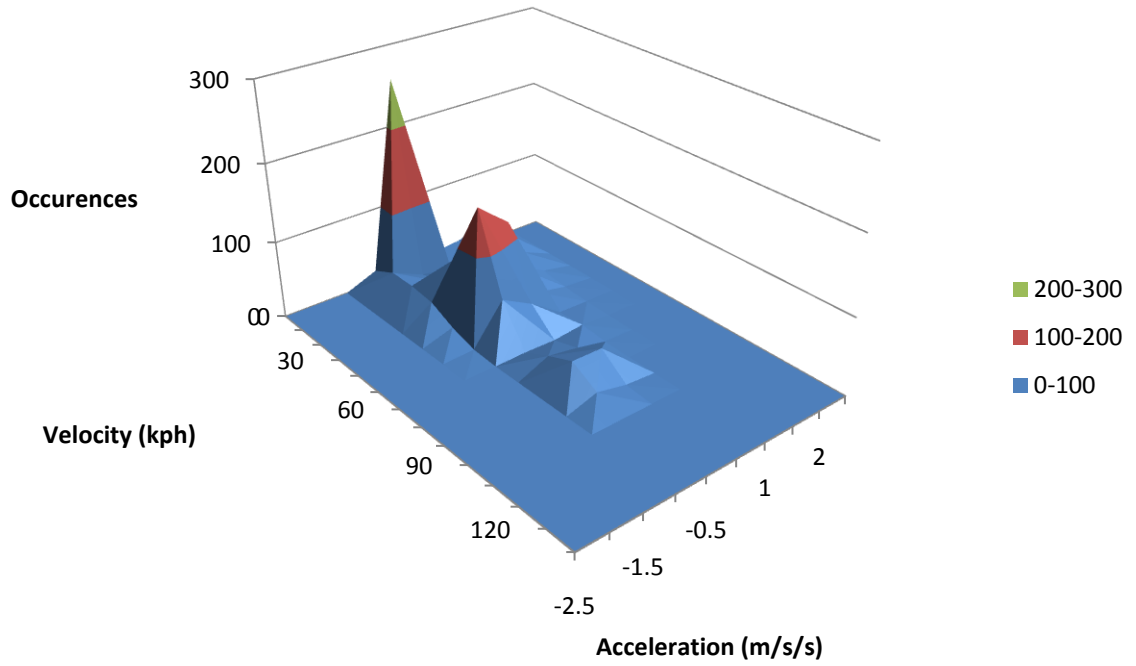

Figure 5.9 UDDS acceleration vs. velocity

US06

Level of Acceleration (m/s ²)	Percent Time
< -2.5	1.33
-2.5 to -1.5	6.66
-1.5 to -1	3.49
-1 to -0.5	6.50
-0.5 to 0	30.2
0 to 0.5	35.7
0.5 to 1	5.66
1 to 1.5	2.50
1.5 to 2.5	5.66
> 2.5	2.33

Table 5.5 US06 acceleration distribution

Vehicle Velocity (kph)	Percent Time
0 to 15	13.8
15 to 30	4.83
30 to 50	8.00
50 to 70	6.49
70 to 90	11.3
90 to 110	36.8
110 to 130	18.8

Table 5.6 US06 velocity distribution

The US06 driving pattern was developed to simulate the affects of high rates of acceleration and speed. It involves driving at high speeds, braking heavily, and accelerating heavily. Figures 5.5 and 5.6 provide graphical representations of velocity versus time and acceleration versus time respectively. At the speeds represented in this model, forces such as drag come into play much more than in other models. This model is important because it can help show the negative effects of aggressive driving on energy consumption and thus on gas mileage. In figure 5.10, the acceleration and velocity are plotted together. In comparing figures 5.7 with figures 5.4 and 5.10, you can observe that this model has greater distribution across both the acceleration and velocity axes.

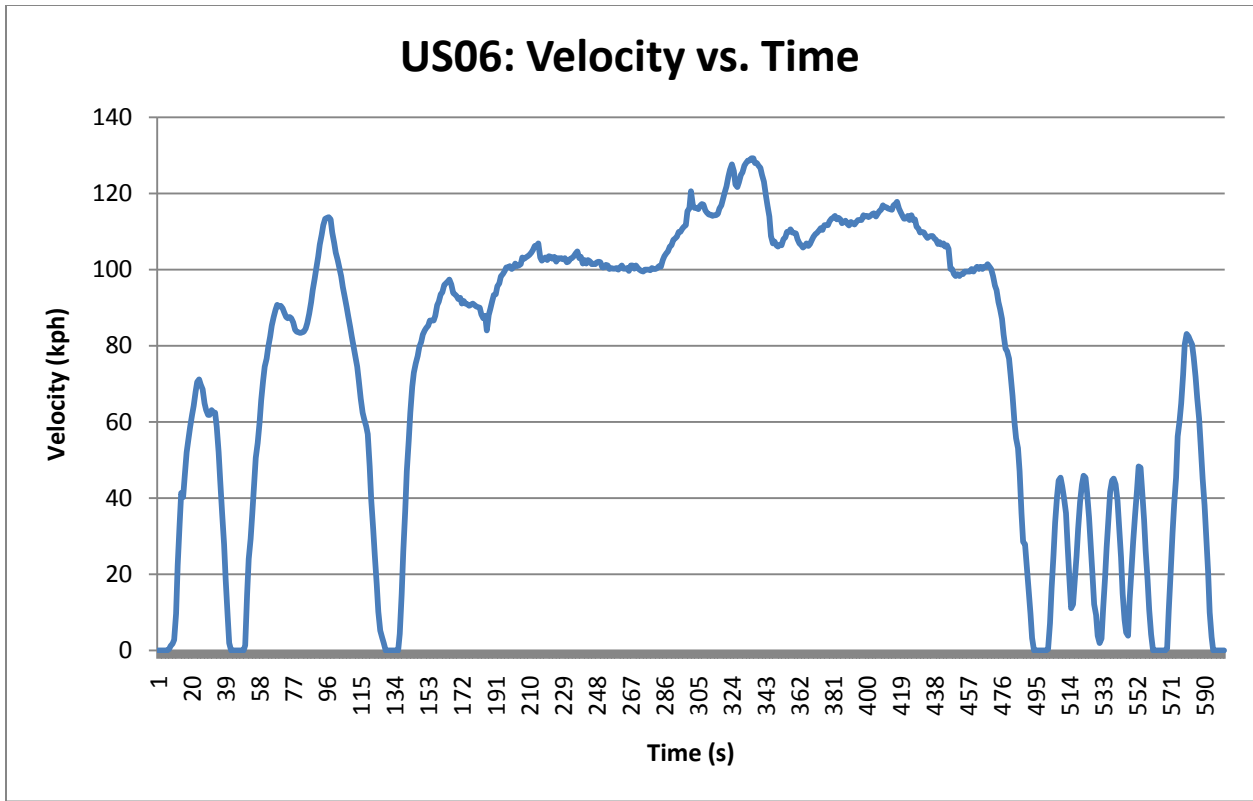

Figure 5.5 US06 velocity vs. time

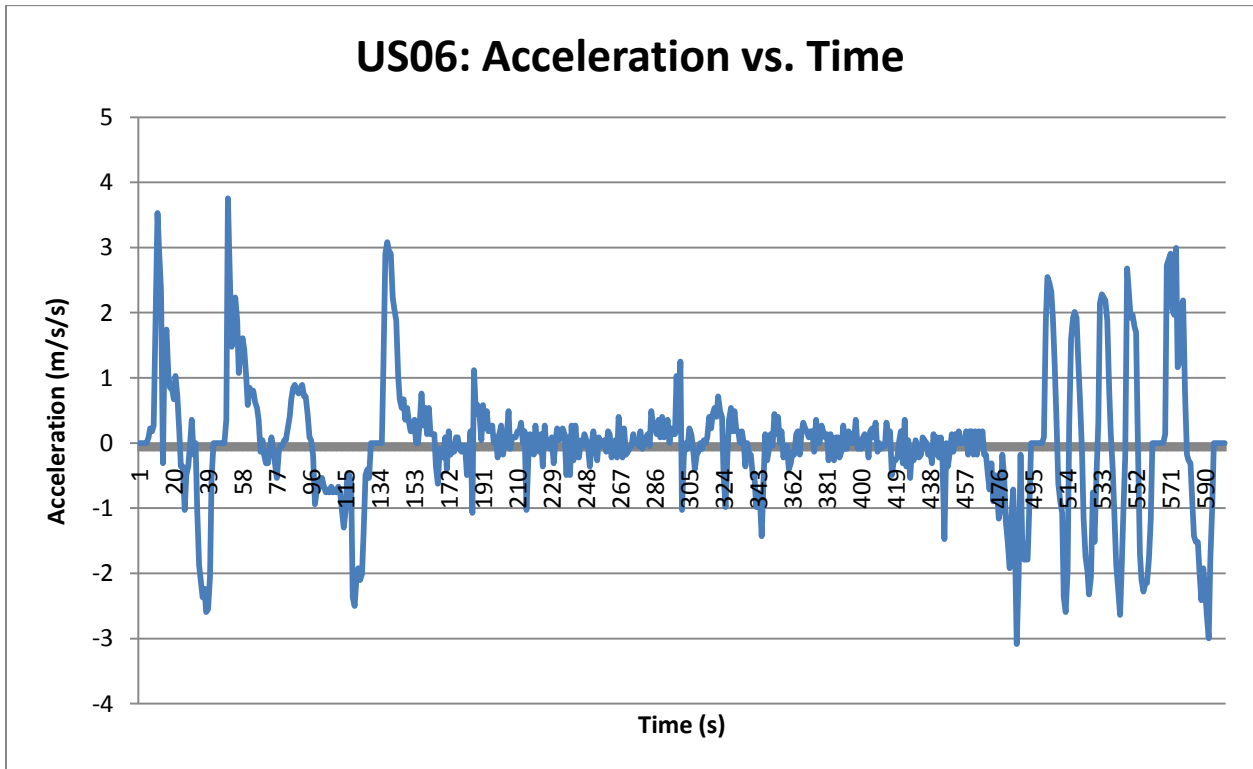

Figure 5.6 US06 acceleration vs. time

US06: Rates of Acceleration at Various Speeds

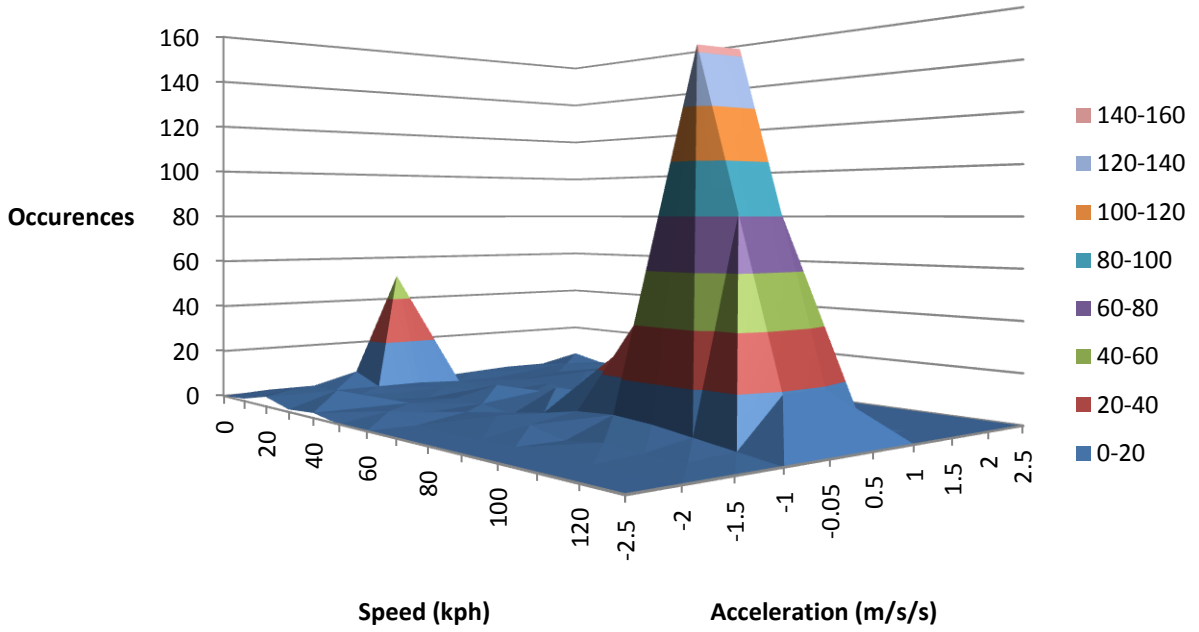

Figure 5.710: US06 acceleration vs. velocity

HWFET

Level of Acceleration (m/s ²)	Percent Time
< -2.5	0
-2.5 to -1.5	0
-1.5 to -1	1.68
-1 to -0.5	2.20
-0.5 to 0	43.5
0 to 0.5	50.5
0.5 to 1	1.42
1 to 1.5	0.78
1.5 to 2.5	0
> 2.5	0

Table 5.7 HWFET acceleration distribution

Vehicle Velocity (kph)	Percent Time
0 to 15	2.65
15 to 30	0.906
30 to 50	2.59
50 to 70	13.9
70 to 90	57.0
90 to 110	23.0
110 to 130	0

Table 5.8 HWFET velocity distribution

Lastly, we examine the U.S. EPA's HWFET driving schedule. We can see from figure 5.8 that there is very little time spent at idle and there is not nearly the degree of "stop and go" driving as in the UDDS urban model. Also, a much higher percent of time is spent at rates of acceleration between -0.5 and 0.5 m/s². Since highway driving tends to involve more consistent speeds than urban driving, this is logical. Figure 5.9 show the acceleration distribution and its tendency to stay close to 0 m/s². As we see in table 5.6 and in figure 5.8, more time is spent at higher speeds. Figure 5.10 shows the velocity versus acceleration. If we compare this to figure 5.4, we see that the HWFET model is more closely distributed around 0 m/s² levels of acceleration, and the speed is more consistently distributed between 40 and 90 kph. This will vary by locale. It may be nigh impossible to represent all highway driving in the U.S. in a single driving pattern model due to the fact that in some places, highway driving tends to be slow and congested, whereas in other places, this is unheard of. Nevertheless, it is currently the standard by which vehicles in the U.S. are measured. Given that all vehicles are subjected to this model, proper comparison nearly dictates that it be used.

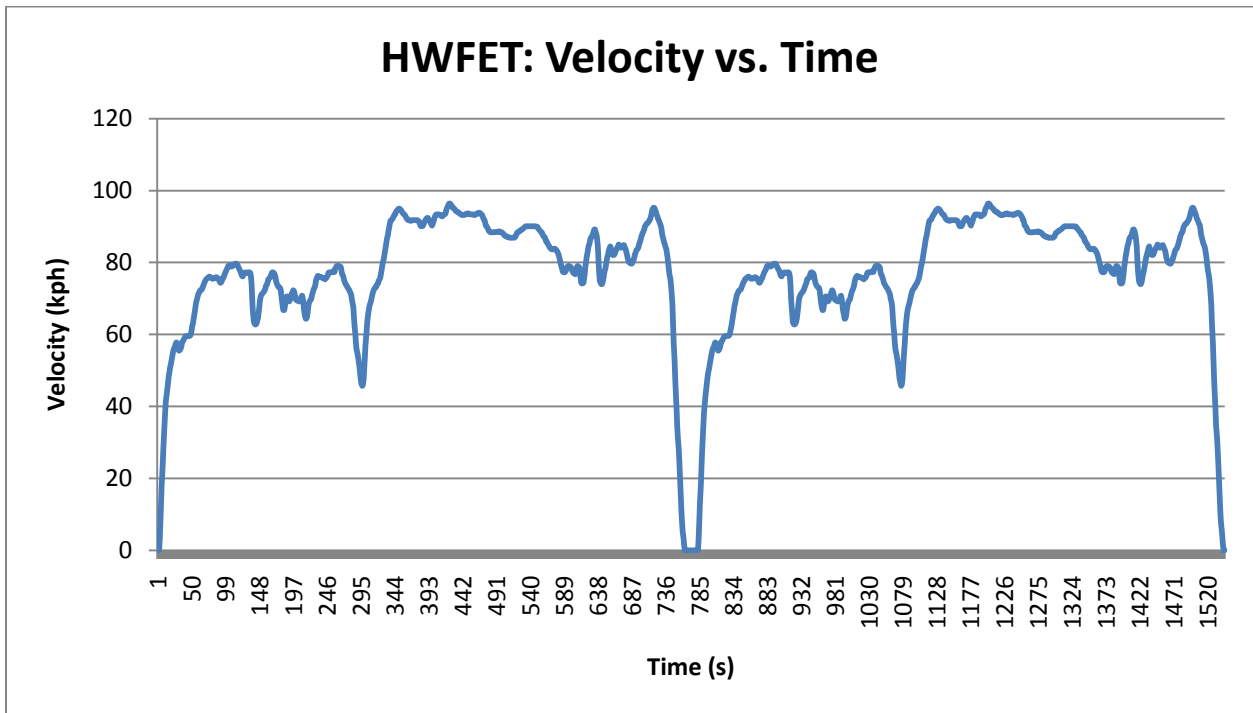

Figure 5.8: HWFET velocity vs. time

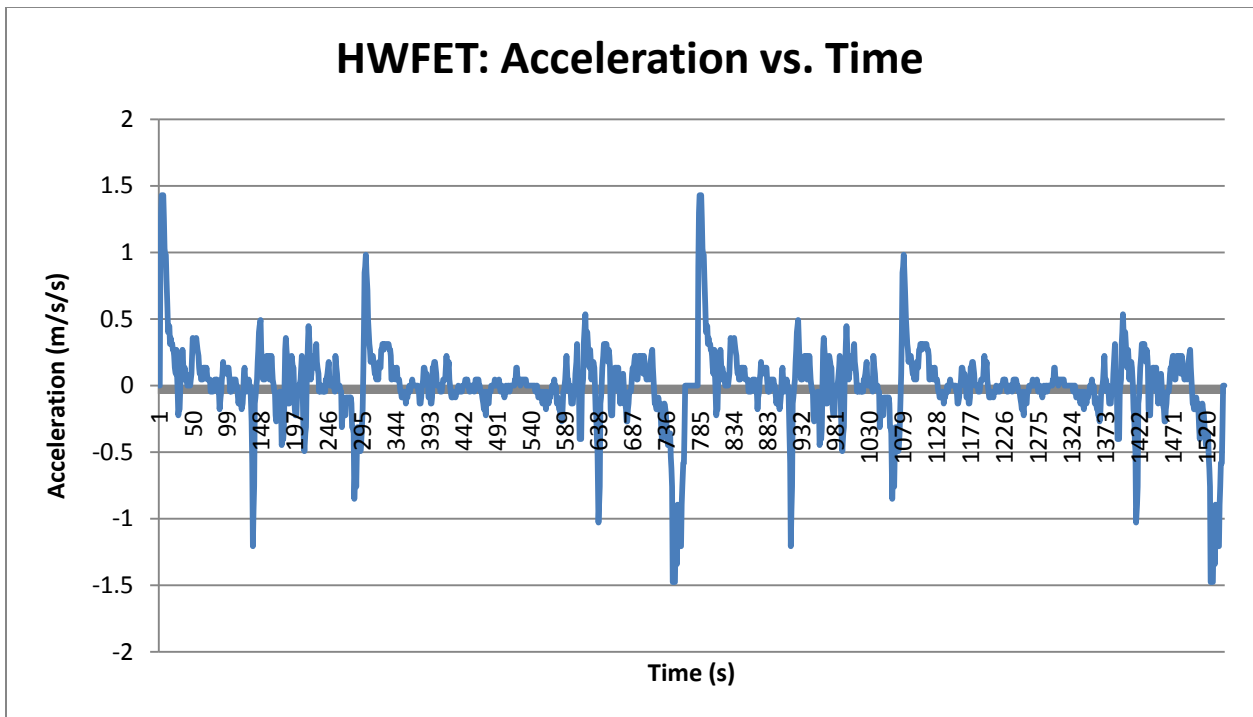

Figure 5.9: HWFET acceleration vs. time

HWFET: Rates of Acceleration at Various Speeds

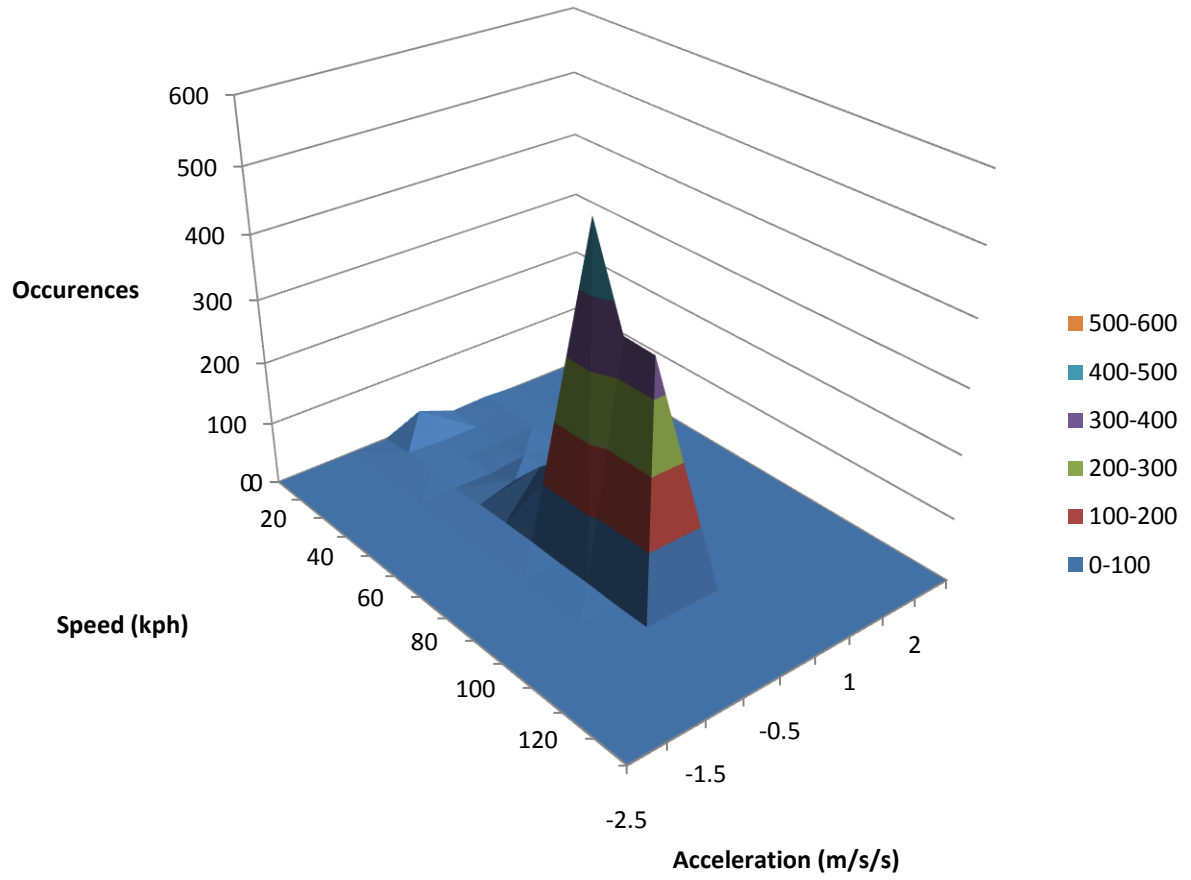

Figure 5.10: HWFET acceleration vs. velocity

The initial observations that can be made from this data is that the majority of time is spent between -0.5 and 0.5 m/s^2 . In other words, cars spend the majority of their time either idling or at more or less constant speed, regardless of conditions. Beyond this, the second largest amount of time is spent in mild to moderate braking or acceleration. This is good news for HEVs, as they are best at recovering energy (regenerative braking) when the forces are milder. Here one might note that in traditional internal combustion engine vehicles, and time spent in negative acceleration (coasting or braking) results in wasted energy. Hybrids, though regenerative braking, do have the means of at least partially recovering this energy.

6: Analysis of Energy Consumption

Having analyzed various models of driving patterns, it is necessary to either aggregate data into a comprehensive model or to utilize a combination of models. For these purposes, Eva Ericsson's urban driving study will be used to represent urban driving conditions as it is based upon real-world data and includes a greater range of accelerations. The EPA HWFET pattern will be used to represent highway conditions as this study applies specifically to the United States. Aggressive driving patterns will be ignored. It is without doubt that aggressive driving results in higher energy consumption and will adversely affect the efficiency and emissions of any drive train, but given the scope of this study, we will leave it to further study. Taking the EPA's assumption of a 55-45 mix of urban and highway driving, we will calculate baseline expenditures for city, highway, and combined.

Baseline Energy Expenditure

The intention of these calculations is to determine a baseline energy expenditure model for road vehicles. The end result will be in joules per kilogram-kilometer. Using this model, we can determine the theoretical amount of energy expended in a hypothetical kilometer of travel (using experimental acceleration data) for a vehicle of a given weight. This can then be compared to the actual energy expenditures of existing vehicles. From here, we can begin to focus on sources of inefficiency and determine what sorts of losses can be minimized or avoided altogether. The secondary intention is the comparison of the various types of propulsion in the hopes that one will stand out amongst the group.

To calculate energy consumption, we must use the following equations from physics:

$$F = m * a$$

$$E = F * d$$

$$E = m * a * d$$

Using the acceleration found in table 5.1, we can find a lossless model for the energy necessary to move 1 kilogram 1 kilometer given average driving patterns.

Notes:

For strictly internal combustion engine vehicles, regeneration of energy during braking is generally not possible, so accelerations in the negative direction will be ignored. Electric-drive vehicle

data (strict electric, parallel hybrid, and series hybrid) will take into account regenerative braking. Using the experimental number of 73% efficiency (Dixon & Ortuzar, 2002) (which is 84% charging efficiency times 87% discharge efficiency) we calculate the added systemic efficiency to electric vehicles of regenerative braking.

For ease of calculation, initial numbers are in metric. The results will be converted to imperial for ease of comprehension.

Negative energy values are energy expenditures, whereas positive energy values are regeneration. Accelerations between 0 and -0.5 m/s^2 have been ignored due to the fact that these values represent coasting conditions wherein no braking is occurring but there is still negative acceleration.

Calculation:

$$E = m * a * d$$

$$E = (1 \text{ kg})(1000 \text{ m})(a)$$

Average Energy Consumption per Kilometer	Percent Time (urban)	Percent Time (highway)
-3500 J	0.056	0
-2000 J	0.65	0
-1250 J	2.7	1.68
-750 J	9.8	2.20
-250 J	39.3	43.5
500 J	35.8	50.5
750 J	6.81	1.42
1250 J	3.12	0.78
2000 J	1.54	0
3500 J	0.14	0

Table 6.1.1: Average energy consumption per kilometer: urban and highway

Table 6.1.1 shows the breakdown of how much energy is spent for how much time, separating urban and highway conditions. By multiplying the percent time by the energy consumption and summing the amount, we arrive at tables 6.1.2 and 6.1.3 for urban and highway conditions respectively.

Urban Results:

	Joules / kg*km	Joules / lb*mi
Average Energy Expended	304.8	222.5
Average Energy Regenerated	160.9	117.5
Average Energy Sum	143.9	105.0

Table 6.1.2: Baseline Energy Expenditure for Urban Driving

Highway Results:

	Joules / kg*km	Joules / lb*mi
Average Energy Expended	272.9	199.2
Average Energy Regenerated	146.3	106.8
Average Energy Sum	126.6	92.4

Table 6.1.3: Baseline Energy Expenditure for Highway Driving

Taking the information in tables 6.1.2 and 6.1.3 and assuming a 45% city 55% highway driving mix, we find the combine results, shown in figure 6.1.4.

	Joules/kg*km	Joules/lb*mi
Average Energy Expended	287.3	209.7
Average Energy Regenerated	152.9	111.6
Average Energy Sum	134.4	98.1

Table 6.1.4: Combined City and Highway Baseline Energy Expenditure

The results in table 6.1.4 show us, assuming standardized driving habits discussed in Section 5, what the absolute minimum average amount of energy a vehicle will require to move one kilometer or one mile. To compare the baseline to a real vehicle, we only need multiply the values in table 6.1.4 by the vehicle's weight. The Average Energy Expended row would be used for vehicles without regenerative ability and the Average Energy Sum row would be used for vehicles with regenerative capabilities.

7: Comparison of Technologies

To compare vehicles and their underlying technologies, we must first define the grounds for comparison. Our areas of focus will be efficiency, economy, environmental impact, and affordability. It should be noted here that unless a vehicle is able to be purchased by the average American consumer, its impact on the system efficiency and ecology of our transportation system will be statistically insignificant. In short: it is well and good to develop an efficient and environmentally sound vehicle, but if it is unaffordable to all but the wealthy, its positive impact will be negligible.

7.1 Baseline

The model, based on rudimentary physics, will attempt to find the ideal (lossless) average energy expenditure for a given unit of distance for a given unit of weight.

We are operating under the following assumptions:

- Gasoline has an energy density of 34.2 MJ/liter (129.5 MJ/Gallon) (IOR Energy)
- Diesel has an energy density of 38.6 MJ/Liter (146.1 MJ/Gallon) (IOR Energy)
- Gasoline emits 19.4 pounds of CO₂ per gallon (Environmental Protection Agency, 2005)
- Diesel emits 22.2 pounds of CO₂ per gallon (Environmental Protection Agency, 2005)
- Well-to-station efficiency of gasoline production is 81.7% (Department of Energy, 2001)
- Average fuel economy for U.S. passenger vehicle is 22.4 mpg (Research and Innovative Technology Administration, 2008)
- Average production of CO₂ per kilowatt-hour in the US is 1.341 lbs (Energy Information Administration, 2003)
- Gasoline costs \$2.58 per gallon (fueleconomy.gov, 2009)
- Diesel costs \$2.63 per gallon (fueleconomy.gov, 2009)
- Electricity costs \$0.1147 per kWh (Energy Information Administration, 2009)

Using empirical driving data, an average of 160.9 Joules per pound per mile was calculated as the baseline energy expenditure with normalized driving habits. This means for example, that for a given mile of travel, a vehicle of 3000 pounds driven by an average person would expend no less than 482.7 kilojoules of energy. For comparison, several specific models have been selected to be compared, as well as national averages. Included are: the 2009 Toyota Prius, the 2009 Volkswagen Jetta (diesel,

manual), the 2009 Tesla Roadster, the average American passenger vehicle, the average 2009 production vehicle, and the theoretical series hybrid.

Table 7.1.1 contains data that may be unusual to most people. The energy consumption listed is the *systemic* energy usage. That is, how much energy is either consumed or lost, from the mines or the oil wells all the way to the vehicle, to drive it one average mile. The following details how the data in table 7.1.1 is calculated.

For cars that run on petroleum fuels, we use the following equation:

$$\frac{\text{Energy Consumption}}{\text{Mile}} = \frac{E_{fuel}}{(mpg)(\eta_{Petro})}$$

Equation 7.1.1

Where E_{fuel} is the energy stored in a gallon of fuel, mpg is the vehicle's mileage rating, and η_{Petro} is the efficiency of petroleum fuel production. To determine the CO₂ emissions of these vehicles, we use this equation:

$$\frac{CO^2 \text{ Emissions}}{\text{Mile}} = \frac{CO^2 \text{ Emissions/Gallon}}{\text{Miles/Gallon}}$$

Equation 7.1.2

For the Tesla, we use the following equation:

$$\text{Energy Consumption} = \frac{E_{wall-to-wheels}}{\eta_{transmission} \eta_{generation}}$$

Equation 7.1.3

Where $E_{wall-to-wheels}$ is the energy consumed by the vehicle, charger, batteries, etc. For the Tesla, this is 0.738 MJ/Mi (Tesla Motors, 2006). $\eta_{transmission}$ is the power line transmission efficiency, and $\eta_{generation}$ is the efficiency of electrical power generation. To determine the CO₂ emissions of electric vehicles, we use:

$$\frac{CO^2 \text{ Emissions}}{\text{Mile}} = \frac{E_{wall to wheels}}{\eta_{transmission}} * \frac{1 \text{ kWh}}{3.6 \text{ MJ}} * \frac{1.341 \text{ lbs } CO^2}{\text{kWh}}$$

Equation 7.1.4

Since the series hybrid does not yet exist, it was necessary to develop a rudimentary model and to make some assumptions as to the specifications of this vehicle. We will assume a vehicle weight of 2900 lbs, comparable to a Toyota Prius (Yahoo! Autos, 2009). For these purposes, we have assumed that it uses an engine comparable to the engine of the Toyota Prius, which has a peak thermal efficiency of 37%. We will choose motor and generator efficiencies of 95%, an inverter efficiency of 94%, and charger and battery efficiencies of 93% (Tesla Motors, 2006) (Washington State University Extension Energy Program, 2009). Thus, the energy consumption is

$$Energy\ Consumption = \frac{E_{baseline} m_{vehicle}}{\eta_{ICE} \eta_{motor} \eta_{generator} \eta_{inverter} \eta_{charger} \eta_{battery} \eta_{petro}} * 1.5$$

Equation 7.1.5

Where $E_{baseline}$ is the combined sum baseline energy expenditure from Section 6.1, $m_{vehicle}$ is the mass of the vehicle, η_{ICE} is the efficiency of the internal combustion engine, η_{motor} is the efficiency of the motor, $\eta_{generator}$ is the efficiency of the generator, $\eta_{inverter}$ is the efficiency of the inverter, $\eta_{battery}$ is the efficiency of the battery, and η_{petro} is the efficiency of petroleum fuel production. We multiply this value by a factor of 1.5 to produce a more conservative estimate. This will attempt to account for peripheral usage and any unforeseen sources of loss. To determine the CO2 emissions of this vehicle, we perform this calculation:

$$\frac{CO^2\ Emissions}{Mile} = \frac{Energy\ Consumption}{E_{fuel}} * CO^2\ Emissions/Gallon$$

Equation 7.1.6

Here, $\frac{Energy\ Consumption}{E_{fuel}}$ gives us mpg-1, so multiplying this quantity by the CO2 emission rate of the fuel gives us the average CO2 emissions per mile.

Vehicle	Energy Consumption (MJ/Mile)	CO2 Emissions (lbs/Mile)	Miles per Gallon	Cost per mile	MSRP
2009 Toyota Prius	3.45	0.517	46	\$0.056	\$22,000
2009 Volkswagen Jetta Diesel	5.08	0.827	34	\$0.077	\$22,000
2009 Tesla Roadster	2.95	0.296	n/a	\$0.025	\$109,000
Average Passenger Vehicle	7.07	1.061	22.4	\$0.115	n/a
2009 CAFE Standard Vehicle	5.08	0.762	27.5 (U.S. Department of Transportation, 2009)	\$0.094	\$26,200 (Shrunk, 2009)
Theoretical Series Hybrid	1.80	0.270	71.9	\$0.036	n/a

Table 7.1.1: Comparison of various vehicles based on economic, ecological, and energy criteria

7.2 Environmental Considerations

There can be difficulty in comparing the environmental impact of assorted vehicle technologies. This is in part the motivation for the creation of a model of vehicle usage. It is well established that driving style and habits are significant factors in how well vehicles make use of energy.

According to government reports, the average CO2 emission in the US as of 2005 is 1.329 lbs/kWh (US Environmental Protection Agency, 2009). This is less than a 1% reduction from 1999, where the average was 1.341 lbs/kWh (Energy Information Administration, 2003). If vehicular energy is to come from electric grid power, we must thoroughly investigate the impact of using energy from this source as opposed to solely petroleum products.

To avoid common misconception, electric vehicles are not inherently “clean”. As has been established, a given vehicle is only as clean as its energy source and how well it uses that power. Nevertheless, as can be observed in Table 7.1.1, the Tesla, assuming average CO2 emissions, has the lowest CO2 emissions of all of the vehicles, excluding the theoretical series hybrid. Since power plant type, average efficiency, and average CO2 emission varies by region, let’s look at a worst-case scenario.

The Mountain region of the US (AZ, CO, ID, MT, NM, NV, UT, and WY) has the highest percentage of coal-generated power (67.9%) and the highest average emissions per kWh (1.572 lbs) (Energy Information Administration, 2003). Therefore, operating a Tesla Roadster in these states would result in an average of 0.347 lbs of CO₂ per mile driven, still placing it in better standing than even the best conventional vehicle or hybrid. The most important thing to remember here is that the CO₂ production is a result of three major factors: power plant type, power plant efficiency, and vehicle energy consumption.

For example, if all of the power to an electric vehicle came from a clean and renewable energy source, it would produce no CO₂ or other emissions. In this case, the amount it cost to run would be directly proportional to its energy consumption, but this would be the only factor affected. CO₂ emissions from fossil fuel powered power plants are inversely proportional to their efficiency. That is to say that if a power plant is producing more power per unit fuel, the rate of emission per unit energy would be reduced. The combustion of a given fuel produces a certain amount of CO₂. If we reduce the amount of fuel necessary to produce one unit of electrical energy, we thereby reduce the amount of CO₂ emitted per unit energy. Lastly, vehicle energy consumption plays a major role. We know that the Tesla uses 2.95 MJ of energy per mile, resulting in the production of 0.296 lbs of CO₂. If it were a less efficient vehicle and it consumed three times as much energy (2.214 MJ/Mi), the production of 0.889 lbs of CO₂ would result, making it not nearly as attractive from an environmental standpoint. Thus we can conclude that electric vehicles have the potential to have very low energy consumption and, despite our current power system, still produce low amounts of CO₂. Nevertheless, this hinges on the efficiency of the vehicle.

Taking some of these issues into consideration, we also find it fruitful to examine the role of PHEVs. Using the findings of A. Simpson in his report for the National Renewable Energy Laboratory, we can extrapolate the following information (Simpson, 2006):

Vehicle Type	Fuel Consumption (mpg)	Elec. Consumption (kJ/Mi)	CO2 Emissions (lbs/Mi)
CV	22.84	--	0.849
HEV0	31.36	--	0.619
PHEV2	32.33	40.5	0.713
PHEV5	33.13	98.5	0.723
PHEV10	35.11	191.1	0.724
PHEV20	39.2	347.5	0.724
PHEV30	43.56	486.6	0.727
PHEV40	49	602.4	0.719
PHEV50	52.27	683.5	0.726
PHEV60	57.37	770.4	0.725

Table 7.2.1 Comparison of hybrids of varying DOH

Here, CV refers to conventional ICE vehicles, HEV0 refers to modern hybrid electrics like the Prius, and PHEV2-PHEV60 refer to hypothetical Plug-In Hybrid Electric vehicle with electric-only ranges of 2 to 60 miles. It should also be noted that this study utilizes the EPA’s UDDS and HWFET driving cycles as the basis for the simulation. The last column is a calculation of CO2 emission based on average power plant emissions combined with EPA standard emissions for the combustion of gasoline. It reflects electrical transmission losses of 7.2% (U.S. Climate Change Technology Program, 2003) and charger losses of 7% (Tesla Motors, 2006). We calculate this value using a combination of Equations 7.1.2 and 7.1.4.

Columns two and three contain information from the report with the mileage converted to mpg and the electrical energy consumption converted to kilojoules per mile. From these numbers we can expect a certain CO2 emission rate based on the cumulative emissions from the ICE and electrical energy generation, which can be found in the third column. From this information, several points are apparent. Firstly, with regard to modern hybrid electrics (HEV0), we find that the fuel consumption predicted in the model underestimates actual mileage of modern HEVs. The value it gives is 31.36 mpg whereas the actual 2009 Toyota Prius has a rated mileage of 46 mpg. This is a significant difference that is not addressed which begs the development of better models that successfully represent the technology that we currently have. Secondly, from the last column it can be observed that CO2 emissions appear to be higher for PHEVs than for HEVs, and remain largely unchanged as the degree of hybridization (DOH) is increased. In fact, there is a small but steady increase in CO2 emissions that begins with more than mild DOH. Also, the comparison to a conventional vehicle with a mileage of 22.84 mpg is somewhat misleading given that 2009 production vehicles have higher average fuel efficiency (U.S. Department of Transportation, 2009). The study is concerned with petroleum offset, but offsetting usage of petroleum fuel usage does not necessarily result in reduced emissions or in increased efficiency. Furthermore, if

offsetting petroleum is only possible through significantly more expensive vehicles, we cannot expect it to happen at all.

7.3 Economic Comparison

If we wish to expect that HEVs, PHEVs, EVs, and other cleaner and more efficient types of transport will represent a large portion of the market share in the future, there will need to be a variety of relatively inexpensive options available to consumers. This not only includes the initial purchase price of a vehicle but its fuel costs and its maintenance costs. Together, this can be called the Total Life Cycle Cost. Using advanced vehicle simulation software such as Advanced Vehicle Simulator (ADVISOR), developed by the National Renewable Energy Laboratory, researchers have developed thorough models for predicting the long term impact of new vehicle technologies with regard to cost and petroleum displacement.

Now that hybrids have been on the roads for nearly a decade, it appears that there are negligible differences in maintenance costs between hybrids and conventional vehicles. Initially, the costs were somewhat higher than average, but given that these hybrids were completely new models, this is to be expected. Figure 7.3.1, based on findings by insurance claim processor Audatex, shows that despite initially costing more, hybrids now tend to cost almost exactly as much to maintain as their traditional counterparts.

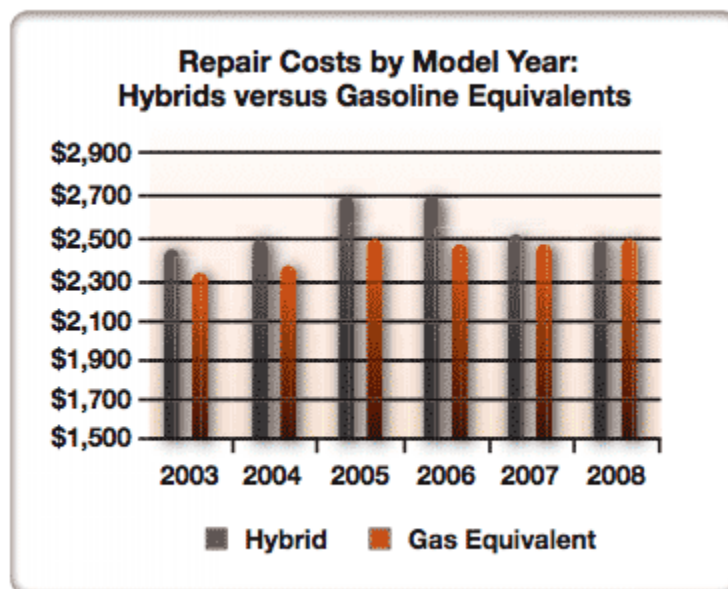

Figure 7.3.2 Gasoline vs. Hybrid Repair cost by Model Year Source: Audatex Insight via hybridcars.com

Even more, there was concern about the “hidden cost” of batteries; many were concerned that battery packs might need to be replaced after a certain number of miles. This would certainly be a very expensive repair that might completely overshadow any other cost benefits of hybrids. However, batteries are expected to have a 150,000 to 180,000 mile life expectancy, and thus far, replacements have been rare (Consumer Reports, 2008). Granted, a replacement battery pack for the Prius costs \$2,588, but this has already come down from \$2985 since their introduction (Toyota Motor Sales, U.S.A., 2008).

When compared to other comparably priced midsize sedans, it can be observed in figure 7.3.2 that the breakeven point occurs at approximately 3.75 years or less, based on fuel savings alone. When pitted against slightly less expensive vehicles like the Chevy Malibu, the breakeven point occurs within the year. Interestingly, if we examine a series hybrid model, with comparable cost and specification to a Prius, we find that the breakeven point versus a vehicle costing \$2000 less MSRP will occur in a mere 1.5 years. Furthermore, over the life of the vehicle, one might expect to have spent \$3000 less than a Prius owner or nearly \$7500 less than the owner of a conventional vehicle. In short, as gas mileage increases, the economic benefits, in both the long and short term, start to become more and more apparent.

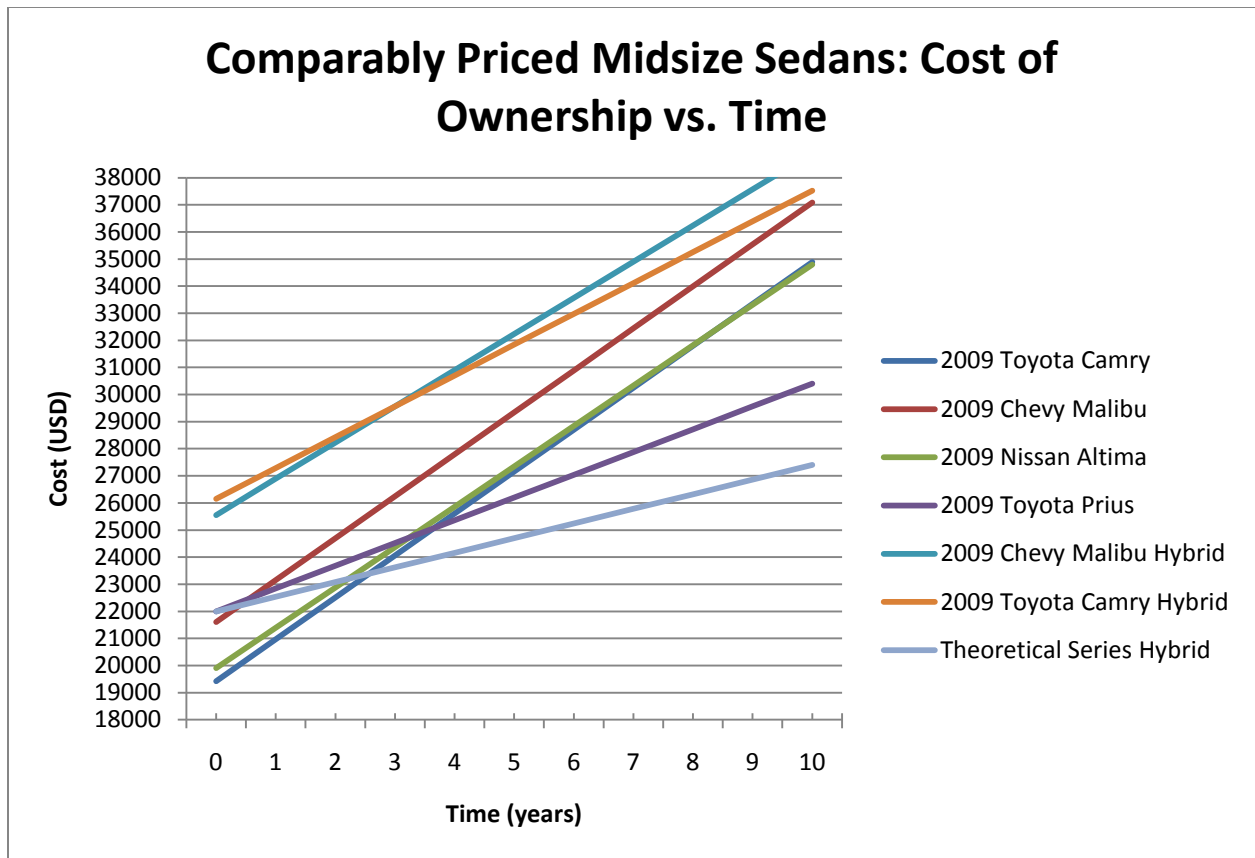

Figure 7.3.2: Long Term Economic Comparison of Midsize Sedans

Another observation that can be made is that hybrids such as the Malibu hybrid and the Camry hybrid, which are more expensive and have lower gas mileage, do not reach a breakeven point in the first ten years. From the consumer standpoint, this is unacceptable, unless the vehicle is a luxury vehicle or offers specific features otherwise desired by a given individual.

It is worth noting here that the Tesla, as shown in table 7.1.1, costs a mere \$0.025 per mile to operate, making it the cheapest in terms of fuel cost by a significant margin. The Tesla however is a \$109,000 vehicle, placing it well outside of the realm of your average consumer. If in the future the technology of the Tesla can be adapted to \$20,000 vehicles, low cost, high efficiency, and low emission vehicles would be the norm. In the meantime, a replacement battery pack for the Tesla costs about \$36,000, and is only rated for 100,000 miles, less than seven years at 15,000 miles per year (Tesla Motors, 2009). Therefore, the battery in the Tesla represents almost a third of its overall cost. Hopefully, battery technology will improve and proliferate to the point where a full-size battery pack for an electric vehicle is comparable in cost to that of a Prius. Until then, hybridization seems the obvious conclusion.

8: Further Considerations

During the course of this research, it comes to our attention that there are serious limitations to much of the modeling that done. The EPA's drive schedules have been an effective standard for vehicular comparison over the past decades, but it appears that there are individual factors beyond what can readily be encapsulated in a small handful of driving patterns. In the future, the development of regional or even individualized driving models may aid in a better understand of our transportation system's energy consumption and environmental impact while providing consumers a more accurate picture of performance and economy. The EPA has already begun to do this to a certain extent with their "Your MPG" survey through the fueleconomy.gov website.

The modeling developed in this paper too has its limitations. Not only is it based on perhaps oversimplified driving models, but its ability to accurately model loss mechanisms is stunted by the scope of the research. The author highly supports the development of open vehicular simulation tools that allow researchers to examine systemic impact, but it is simply beyond the scope of this IQP to do so. With this noted it should be stated that the estimates for the series hybrid vehicle may not be accurate or take into account all the necessary elements. An attempt was made to account for the unknown with the 150% "fudge factor" found in equation 7.1.5, but it is difficult to determine if this is even conservative or liberal.

9: Conclusions

From an examination of the strengths and weaknesses of these systems, several points can be made. Firstly, cost is paramount. If auto manufacturers are unable to produce an affordable vehicle that meets high environmental and efficiency standards, national average efficiency and greenhouse gas production will remain largely unchanged. At this point in time, battery technology has improved substantially in term of energy and power density, but the costs are still quite high. Thus, to reduce cost, it is necessary to minimize the amount of batteries a vehicle needs. As the energy expenditure of a vehicle drops, its fuel consumption drops, and thus its operational costs drop. As shown in section 7, increased mileage due to hybridization can justify the additional cost of a vehicle, in potentially as little as a year and a half. It is true that highly efficient electric vehicles would have the cheapest fuel costs, but the cars themselves are still very expensive. We should continue to invest in their development in the hopes that an affordable implementation will soon be a reality, but as noted in section 7, it appears hybridization is indeed the best compromise in the interim.

With regard to energy consumption and emission control, it appears that the best approach for the short term will involve exploiting the highest efficiency power source available. Though perhaps in the future we will have a cleaner and more efficient electric grid, as it stands using purely electric power or a heavy percentage of electric power will be too expensive to be viable. Given this, we should divert our short term goals from battery-based PHEVs and EVs to hybrid electric vehicles with minimal electric storage capacity and the highest fuel-to-useable energy conversion efficiency possible. Doing so, we can make use of the efficient systems that we do have, reduce overall energy consumption, reduce GHG emissions, and make an affordable vehicle while simultaneously generating demand for new battery technology. If we continue to improve our electric generation system, invest in renewable energy sources, and continue to research battery technology, we will reach a point at which clean, renewable energy and vehicles will be utterly feasible and affordable. In the interim, it is necessary that the movement towards better technologies and reduced waste be all inclusive or we risk creating a society in which ecology and efficiency are inversely proportional to economics. The only way to do this is to prioritize affordable solutions above all, as the greatest number will have the greatest overall effect.

More specifically, the recommendation of this paper is research into and development of vehicles not unlike the Extended Range Electric vehicles now being developed, but with minimal or no ability to run exclusively on grid-derived battery power. If it is possible to design a vehicle with only

enough electric storage so as to buffer power from a generator and to draw from during moments of heavy acceleration, the result will be a smaller battery pack which means lower cost, weight, and materials. It appears that the best way to achieve high efficiency would be to operate the vehicle in a series hybrid configuration such that a small internal combustion engine could be run at constant peak efficiency. Though this would continue our dependence on fossil fuels which so many oppose, it would constitute a “weaning off” that would better prepare us for a clean, efficient, and petroleum-free transportation system.

Bibliography

A123 Systems. (2008). *Hymotion*. Retrieved April 8, 2009, from Convert your hybrid vehicle into a plug-in hybrid electric vehicle: https://www.a123systems.com/hymotion/products/reserve_yours

Andre, M., Joumard, R., Vidon, R., Tassel, P., & Perret, P. (2005). *Real-World European driving cycles, for measuring pollutant emissions from high- and low-powered cars*. Cedex, France: Atmospheric Environment.

Casten, S. (2008, June 26). *Power Plant Efficiency Hasn't Improved Since 1957*. Retrieved March 10, 2009, from Clean Technica: <http://cleantechnica.com/2008/06/26/electricity-generation-efficiency-its-not-about-the-technology/>

Certified Toyota Hybrids. (2009, 5 13). *Better Aerodynamics = Better MPG!* Retrieved 9 24, 2009, from Certified Toyota Hybrids: <http://www.certifiedtoyotahybrids.com/better-aerodynamics-better-mpg/>

Chrysler Group LLC. (2009). *Chrysler Group LLC: Innovation -- ENVI*. Retrieved October 16, 2009, from Chrysler Group LLC: <https://www.chryslergroupllc.com/en/innovation/envi/overview/>

Chrysler LLC. (2009). *Chrysler LLC*. Retrieved April 9, 2009, from Innovation - ENVI: <https://www.chryslerllc.com/en/innovation/envi/overview/>

Cogan, R. (2008, 5 26). *20 Truths About the GM EV1 Electric Car*. Retrieved 9 24, 2009, from GreenCar.com: <http://www.greencar.com/articles/20-truths-gm-ev1-electric-car.php>

Consumer Reports. (2008, September). *Which are the Most Affordable Hybrids vs. Standard Cars?* Retrieved October 11, 2009, from Consumer Reports: <http://www.consumerreports.org/cro/cars/new-cars/news/2008/10/affordable-hybrids/overview/affordable-hybrids-ov.htm>

Department of Energy. (2001). *Fischer-Tropsch Archive*. Retrieved April 9, 2009, from Well to Wheels Energy Use and Greenhouse Gas Emissions of Advanced Fuel/Vehicles Systems Volumes 1, 2, and 3: http://www.fischer-tropsch.org/DOE/DOE_reports/well2wheel/well2wheel.htm

Dixon, J., & Ortuzar, M. (2002, Aug). *"Ultracapacitors + DC-DC converters in regenerative braking system,"*. Retrieved from <http://ieeexplore.ieee.org/stamp/stamp.jsp?arnumber=1028079&isnumber=22086>

Duoba, M. (1999, October 28). *Performance and Emission1*. Retrieved October 11, 2009, from transportation.anl.gov: <http://www.transportation.anl.gov/pdfs/HV/2.pdf>

Eaton Corporation. (2009). *Hydraulic Launch Assist, Hydraulic Hybrid*. Retrieved April 7, 2009, from Eaton Corporation: http://www.eaton.com/EatonCom/ProductsServices/Hybrid/SystemsOverview/HydraulicHLA/CT_132100

Energy Information Administration. (2003, April 28). *CO2 Emissions Report*. Retrieved April 20, 2009, from Energy Information Administration: http://www.eia.doe.gov/cneaf/electricity/page/co2_report/co2report.html#electric

Energy Information Administration. (2009, September 11). *Electric Power Monthly - Average Retail Price of Electricity to Ultimate Customers by End-Use Sector, by State*. Retrieved October 16, 2009, from Energy Information Administration: http://www.eia.doe.gov/cneaf/electricity/epm/table5_6_b.html

Environmental Protection Agency. (2005, February). *Environmental Protection Agency*. Retrieved April 3, 2009, from Emission Facts: Average Carbon Dioxide Emissions Resulting from Gasoline and Diesel Fuel: <http://www.epa.gov/OMS/climate/420f05001.htm>

FuelEconomy.gov. (2008). *2008 Fuel Economy Tests*. Retrieved October 1, 2009, from fueleconomy.gov: <http://fueleconomy.gov/feg/ratings2008.shtml>

fueleconomy.gov. (2009). *fueleconomy.gov*. Retrieved April 8, 2009, from Tips to Improve Your Gas Mileage: <http://fueleconomy.gov/feg/driveHabits.shtml>

General Motors Corporation. (2008). *Chevrolet*. Retrieved April 9, 2009, from Chevy Volt. Fully Charged 2010: <http://www.chevrolet.com/electriccar/>

Glinksy, G., Hieronymus, A., Kelly, K., & Zolot, M. (2001, August 20). *Test Results and Modeling of the Honda Insight Using ADVISOR*. Retrieved October 16, 2009, from National Renewable Energy Laboratory: <http://www.nrel.gov/docs/fy01osti/31085.pdf>

Hodges, A. W., & Rahmani, M. (2009). *FE796/FE796: Fuel Sources and Carbon Dioxide Emissions by Electric Power Plants in the United States*. Retrieved September 29, 2009, from University of Florida: <http://edis.ifas.ufl.edu/FE796>

IOR Energy. (n.d.). *IOR Energy*. Retrieved April 1, 2009, from List of Common Conversion Factors: <http://www.ior.com.au/ecflist.html>

Mitsubishi Motors Corporation. (2008, July). *Mitsubishi Motors Japan*. Retrieved April 8, 2009, from about i MiEV: <http://www.mitsubishi-motors.com/special/ev/index.html>

Montoya, R. (n.d.). *The Advantages of Buying a Manual-Transmission Vehicle - Edmunds.com*. Retrieved 10 10, 2009, from edmunds.com: <http://www.edmunds.com/advice/buying/articles/131235/article.html>

Morgan, M. G. (2006). Don't Grandfather Coal Plants. *Science*, 314.

Research and Innovative Technology Administration. (2008). *Bureau of Transportation Statistics*. Retrieved April 9, 2009, from Average Fuel Efficiency of U.S. Passenger Cars and Light Trucks: http://www.bts.gov/publications/national_transportation_statistics/html/table_04_23.html

Roth, E. (2005, February 15). *Why Thermal Power Plants Have A Relatively Low Efficiency*. Retrieved October 16, 2009, from SealNET: <http://www.sealnet.org/s/9.pdf>

Shrunk, C. (2009, August 18). *STUDY: Average car costs 22.1 weeks of median family income, average price at \$26,300*. Retrieved September 15, 2009, from autoblog: <http://www.autoblog.com/2009/08/18/study-average-car-costs-22-1-weeks-of-median-family-income-ave/>

Simpson, A. (2006). *Cost-Benefit Analysis of Plug-In Hybrid Electric Vehicle Technology. 22nd International Battery, Hybrid and Fuel Cell Electric Vehicle Symposium and Exhibition*. Yokohama, Japan: National Renewable Energy Laboratory.

Tesla Motors. (2009, February 12). *Tesla Motors - Leadership*. Retrieved October 16, 2009, from Tesla Motors: <http://www.teslamotors.com/blog2/?p=70>

Tesla Motors. (2006, October 6). *The 21st Century Electric Car*. Retrieved January 12, 2009, from Stanford.edu: <http://www.stanford.edu/group/greendorm/participate/cee124/TeslaReading.pdf>

Toyota Motor Sales, U.S.A. (2009). *Toyota*. Retrieved April 8, 2009, from 2009 Toyota Prius Hybrid: <http://www.toyota.com/prius-hybrid/>

Toyota Motor Sales, U.S.A. (2008, September 24). *Toyota Vehicles: Toyota Announces Price Reduction On Prius Hybrid Batteries / Toyota*. Retrieved October 11, 2009, from toyota.com: <http://pressroom.toyota.com/pr/tms/toyota/TYT2008092372406.aspx?ncid=11092>

Turley, J. (2003, August 11). *Embedded.com - Motoring with Microprocessors*. Retrieved August 7, 2009, from Embedded: http://www.embedded.com/columns/significantbits/13000166?_requestid=373775

U.S. Climate Change Technology Program. (2003). *Technology Options for the Near and Long Term*. U.S. Climate Change Technology Program.

U.S. Department of Transportation. (2009). *Summary of Fuel Economy Performance*. Washington, DC: U.S. Department of Transportation.

US Environmental Protection Agency. (2009, April 27). *eGRID | Clean Energy | US EPA*. Retrieved October 2, 2009, from US EPA: <http://www.epa.gov/cleanenergy/energy-resources/egrid/index.html>

Vawter, D. R. (2009, 9). *Drag Force*. Retrieved 9 24, 2009, from Western Washington University: <http://www.ac.wvu.edu/~vawter/PhysicsNet/Topics/Dynamics/Forces/DragForce.html>

Wakefield, E. H. (1998). *History of the Electric Automobile: Hybrid Electric Vehicles*. Warrendale, PA: Society of Automotive Engineers.

Washington State University Extension Energy Program. (2009). *Energy Efficiency Standards*. Retrieved October 15, 2009, from Washington State University Extension Energy Program: <http://www.energy.wsu.edu/documents/engineering/motors/EfficiencyStandards.pdf>

Wertheimer, H. (2009, October 13). *Energy Tribune- More Ethanol Equals More CO2 Emissions*. Retrieved October 15, 2009, from Energy Tribune:
<http://www.energytribune.com/articles.cfm?aid=2437>

Wikipedia. (2009, 9 29). *Speed limits in the United States*. Retrieved 9 30, 2009, from Wikipedia:
http://en.wikipedia.org/wiki/Speed_limits_in_the_United_States

WIRED. (2008, February 12). *Wired.com*. Retrieved April 9, 2009, from Wipers, Stereo Raise Price of Chevrolet Volt to \$35,000: <http://blog.wired.com/cars/2008/02/wipers-stereo-p.html>

www.fueleconomy.gov. (2009). *www.fueleconomy.gov*. Retrieved April 9, 2009, from Most and Least Fuel Efficient Cars: <http://www.fueleconomy.gov/FEG/bestworst.shtml>

Yahoo! Autos. (2009). *Specifications - 2009 Toyota Prius 4-Door Liftback*. Retrieved October 15, 2009, from Yahoo! Autos: http://autos.yahoo.com/2009_toyota_prius_4_door_liftback-specs/