

5-25-2018

Antibiotic Resistance and Cell-Wall Recycling in *Pseudomonas aeruginosa*

Supurna Dhar
sdhar003@fiu.edu

DOI: 10.25148/etd.FIDC006816

Follow this and additional works at: <https://digitalcommons.fiu.edu/etd>

 Part of the [Medicine and Health Sciences Commons](#)

Recommended Citation

Dhar, Supurna, "Antibiotic Resistance and Cell-Wall Recycling in *Pseudomonas aeruginosa*" (2018). *FIU Electronic Theses and Dissertations*. 3817.

<https://digitalcommons.fiu.edu/etd/3817>

This work is brought to you for free and open access by the University Graduate School at FIU Digital Commons. It has been accepted for inclusion in FIU Electronic Theses and Dissertations by an authorized administrator of FIU Digital Commons. For more information, please contact dcc@fiu.edu.

FLORIDA INTERNATIONAL UNIVERSITY

Miami, Florida

ANTIBIOTIC RESISTANCE AND CELL-WALL RECYCLING IN *PSEUDOMONAS*
AERUGINOSA

A dissertation submitted in partial fulfillment of

the requirements for the degree of

DOCTOR OF PHILOSOPHY

in

BIOMEDICAL SCIENCES

by

Supurna Dhar

2018

To: Dean John Rock
College of Medicine

This dissertation, written by Supurna Dhar, and entitled and Antibiotic Resistance and Cell-Wall Recycling in *Pseudomonas aeruginosa*, having been approved in respect to style and intellectual content, is referred to you for judgment.

We have read this dissertation and recommend that it be approved.

Jeremy Chambers

Yukching Tse-Dinh

Marisela Agudelo

Shahriar Mobashery

Kalai Mathee, Major Professor

Date of Defense: May 25, 2018

The dissertation of Supurna Dhar is approved.

Dean John Rock
College of Medicine

Andrés G. Gil
Vice President for Research and Economic Development
and Dean of the University Graduate School

Florida International University, 2018

ACKNOWLEDGMENTS

Firstly, I would like to acknowledge my mentor Dr. Kalai Mathee for all her guidance, support and encouragement over the years. Her intellectual curiosity, enthusiasm and dedication are an inspiration. I sincerely acknowledge all my dissertation committee members Dr. Jeremy Chambers, Dr. Marisela Agudelo, Dr. Yuk ching Tse-Dinh and Dr. Shahriar Mobashery for their critical suggestions, and helpful discussions on my research. I am extremely grateful to Dr. Mobashery for allowing me to spend summer of 2014 and 2017 in his lab. It was an excellent opportunity to conduct important research and interact with his talented lab members who were all extremely welcoming! I am very grateful to Dr. Mijoon Lee for her remarkable guidance on my project. Thanks to Dr. Gagani Athauda and Dr. Weiler as my mentors during my TA. I would also like to acknowledge Dr. Agoulnik, our Program Director for his constant support throughout the Ph.D. program. I am also very grateful for the support provided by Herbert Wertheim College of Medicine in form of Teaching and Graduate assistantships. I am thankful for the funding provided by National Institutes of Health-MBRS RISE program for a summer research award, 2017 and to University Graduate School, FIU for the Dissertation Year Fellowship.

Ph.D. has its own highs and lows and I am glad I had a group of amazing friends with me on this journey. My friends from Manipal- Gayathri, Gowri, Forum and Mommy Kumari. Cheryl Engineer, for becoming my extended family here. My friends at FIU – Adwait, Mansi, Priyanka, Ketaki, Mayur, Sowmya, and KC. Shashank, Iru, and Jiao Jiao- I joined FIU with them and I couldn't have asked for a better cohort. I am thankful to have spent these years with the members of the Mathee lab, an extraordinary and purposeful group of people, both past and present-Deepak, Diansy, Gorakh, Sundar,

Jonathon, Kyle, Kevin, Sameer, Brett, MariaVictoria, and Ana. I am grateful to Dr. Hansi Kumari for taking me under her wing and providing me with outstanding mentoring. Finally, my family, especially my parents- Mr. Suman and Mrs. Sanchita Dhar, and my brother Dr. Sujan Dhar and sis in-law Ms Deepti Nair for providing support, love and good cheer always.

ABSTRACT OF THE DISSERTATION

ANTIBIOTIC RESISTANCE AND CELL-WALL RECYCLING IN *PSEUDOMONAS*

AERUGINOSA

by

Supurna Dhar

Florida International University, 2018

Miami, Florida

Professor Kalai Mathee, Major Professor

An exponential increase in infections by multi-drug, extensive-drug, and pan-drug resistant bacteria in both developed and developing countries are poised to return us to the pre-antibiotic era. *Pseudomonas aeruginosa*, a Gram-negative bacterium is frequently associated with fatal infections and has been classified by the WHO and the CDC as a pathogen of “critical” importance, and serious threat, respectively. *P. aeruginosa* infections are often treated using a combination of a β -lactam and an aminoglycoside. Resistance to β -lactams is conferred by the constitutive expression of a chromosomally-encoded AmpC β -lactamase. The *ampC* expression is regulated by AmpR, a membrane-spanning transcriptional regulator of the LysR family. AmpR is presumed to be activated by muramyl peptides generated in the presence of β -lactams. The muramyl peptides are assumed to shuttle using two permeases, PA4393 (AmpG) and PA4218 (AmpP), importing and exporting into and out of periplasm from the cytoplasm, respectively. To date, the identity of *P. aeruginosa* muramyl peptides, and the AmpR effectors, the AmpG and AmpP substrates have not been elucidated. Using liquid chromatography/mass spectrometry analyses, we clarified the structures and quantified the muramyl peptides of wild-type *P. aeruginosa* PAO1. Twenty muropeptides from PAO1 were identified; and the least and the most metabolites are 100 and 55,000

molecules per bacterium, respectively. Two AmpR-signaling muropeptides, N-acetylglucosamine-1,6-anhydro-N-acetylmuramyl pentapeptide and 1,6-anhydro-N-acetylmuramyl pentapeptide were identified. The role of two permeases in antibiotic resistance and cell-wall recycling were investigated by comparing PAO1 with its isogenic $\Delta ampG$, $\Delta ampP$, and $\Delta ampGampP$ mutants. Our study demonstrates that AmpG and AmpP may play a role in transport of disaccharide-muropeptides. The muropeptide profiles alluded to the presence of a novel periplasmic N-acetyl β -D glucosaminidase and led to the analyses of PA1085 (FlgJ). The loss of *flgJ* resulted in affecting swimming and biofilm production but failed to abolish the periplasmic glucosaminidase activity. In our effort to identify inhibitors of AmpR, novel reporter-based screening assays were developed using AmpR-regulated P_{ampC} , P_{phzA1} , and P_{mexE} promoters. We have identified pyrollidine-based scaffold library with the highest inhibitory effect against the AmpR system. In summary, this dissertation increases our understanding of cell-wall recycling and mechanisms of β -lactam resistance and attempts at establishing novel-antibacterial targets.

TABLE OF CONTENTS

CHAPTER	PAGE
CHAPTER 1	
1. Introduction.....	1
1.1 <i>Pseudomonas aeruginosa</i>	2
1.2 Virulence in <i>P. aeruginosa</i>	5
1.3 Antibiotic resistance in <i>P. aeruginosa</i>	9
1.3.1 Permeability barriers.....	10
1.3.2 Efflux-mediated resistance.....	12
1.3.3 Target modification	13
1.3.4 β -lactamase mediated resistance	14
1.4 Regulation of AmpC β -lactamase expression.....	18
1.5 Cell-wall recycling and synthesis in <i>Escherichia coli</i> and <i>P. aeruginosa</i>	18
1.5.1 Cell-wall biochemistry	20
1.5.2 Cell-wall biosynthesis	21
1.5.3 Peptidoglycan growth	27
1.5.4 Cell-wall recycling.....	28
1.5.5 Convergence of recycling and biosynthesis	42
1.6. Cell-wall recycling and antibiotic resistance	44
1.6.1 β -Lactam resistance involving Amp pathway	45
1.6.2 β -Lactam resistance through other cell-wall-related genes	50
1.6.3 Indirect regulation of β -lactam resistance through AmpR	52
1.6.4 Cell-wall components contributing to non- β -lactam resistance	53
1.7 Dissertation overview.....	56
Chapter 2	
2. Muropeptides in <i>Pseudomonas aeruginosa</i> and their role as elicitors of β -Lactam antibiotic resistance.....	58
2.1 Overview.....	59
2.2 Abstract.....	59
2.3 Introduction	60
2.4 Materials and methods	62
2.4.1 Strains, media and growth conditions	62
2.4.2 Induction and β -lactamase assay	62
2.4.3 Bacterial cell counting.....	63
2.4.4 Syntheses of authentic muropeptides	63
2.4.5 Sample preparation: release of muramyl peptides from whole-cell	67
2.4.6 Detection and quantification of muropeptides by LC/MS	67
2.4.7 Calculation of number of muropeptides per cell	68
2.5 Results and Discussion.....	69
2.6 Acknowledgements.....	78
Chapter 3	
3. Role of <i>P. aeruginosa</i> permeases PA4393 and PA4218 in antibiotic resistance and cell-wall recycling.....	79

3.1 Abstract.....	80
3.2 Introduction	81
3.3 Materials and Methods.....	85
3.3.1 Strains, media and growth conditions	85
3.3.2 Construction of <i>ampG</i> and <i>ampP</i> deletion mutants by homologous recombination	86
3.3.3 Construction of complementing plasmids.....	89
3.3.4 Growth curves	89
3.3.5 Determination of minimum inhibitory concentration (MIC)	90
3.3.6 Quantifying β -lactamase activity	90
3.3.7 Release of muramyl peptides from whole cell extracts	90
3.3.8 Release of muramyl peptides from periplasm	91
3.3.9 Detection of muropeptides by liquid chromatography/mass spectrometry	91
3.3.10 Statistical analyses	92
3.4. Results and Discussion.....	92
3.4.1 Growth analysis of mutant strains	92
3.4.2 MIC of β -lactams is altered in <i>ampG</i> deletion	93
3.4.3 β -lactamase expression is reduced in <i>ampG</i> deletion mutants	94
3.4.4 MIC and β -lactamase expression is unaltered in <i>ampP</i> deletion	96
3.4.5 Muropeptide profile of whole-cell extract in mutant strains	98
3.4.6 Muropeptide profile of periplasmic extract in mutant strains	99
3.4.7 Decrease of disaccharide in PAO Δ <i>ampP</i> periplasm and increase presence of disaccharide in PAO Δ <i>ampG</i> periplasm.....	102
3.5 Concluding Remarks.....	103
3.6 Acknowledgements.....	106

Chapter 4

4. Elucidating the role of PA1085 in <i>Pseudomonas aeruginosa</i>	107
4.1 Abstract.....	108
4.2 Introduction	109
4.3 Materials and Methods.....	114
4.3.1 Strains, media and growth conditions	114
4.3.2 Construction of <i>flgJ</i> deletion mutants by homologous recombination using Gibson cloning	115
4.3.3 Construction of <i>flgJ</i> complementing clones.....	116
4.3.4 Minimum-inhibitory concentration (MIC)	117
4.3.5 Motility assays	117
4.3.6 Biofilm assay	117
4.3.7 <i>N</i> -acetylglucosaminidase assay	118
4.4 Results	118
4.4.1 <i>flgJ</i> is required for swimming motility	118
4.4.2 <i>flgJ</i> is required for initiation of biofilm	119
4.4.3 MIC of selected antibiotics is unaltered in absence of <i>flgJ</i>	120
4.4.4 <i>N</i> -acetylglucosaminidase assay	121
4.5 Discussion	123

4.6 Acknowledgements.....	126
Chapter 5	
5. Small-molecule screening for AmpR inhibitors.....	127
5.1 Abstract.....	128
5.2. Introduction.....	128
5.3. Materials and methods.....	133
5.3.1. Strains, media and growth conditions.....	133
5.3.2. Membrane fractionation.....	133
5.3.3. Modeling of AmpR.....	134
5.3.4. Reporter construction for luciferase assays.....	134
5.3.5 Luciferase assays of reporter strains.....	138
5.3.6 Primary screen with compounds from Torrey Pines.....	138
5.3.7 Statistical analyses.....	139
5.4. Results.....	139
5.4.1. AmpR is localized in the membrane.....	139
5.4.2. Gly102Glu leads to structural instability whereas Asp135Asn stabilizes AmpR dimer.....	140
5.4.3 Validation of reporter constructs.....	142
5.4.4. Primary screen of Torrey Pines Compounds.....	144
5.5. Discussion.....	144
5.6. Acknowledgements.....	148
Chapter 6	
6. Overview, Summary and Future directions.....	149
6.1. Overview.....	150
6. 2. Muropeptides in <i>P. aeruginosa</i> and AmpR effector.....	153
6. 3. AmpG and AmpP play a role in cell wall recycling.....	156
6. 4. Role of PA1085 in <i>P. aeruginosa</i>	157
6.5. Screening of small molecule library for AmpR inhibitors	158
6.6. Future Directions.....	159
APPENDIX.....	166
References.....	185
VITA.....	231

LIST OF TABLES

TABLE	PAGE
1.1. List of genes involved in cell-wall synthesis	26
1.2. List of genes involved in cell-wall recycling	37
1.3. MIC of mutant strains of <i>P. aeruginosa</i>	48
2.1. Detected mucopeptides from whole-cell analysis	74
2.2. Induction of β -lactamase activity by three inducers.....	77
3.1. Strains plasmids and primer used in the study.....	87
3. 2. Susceptibility profile of PAO $\Delta ampG$, PAO $\Delta ampP$ and PAO $\Delta ampG\Delta ampP$	95
4.1. Protein homology between <i>S. enterica</i> and <i>P. aeruginosa</i> FlgJ	111
4.2. Strains, plasmid and primer used in this study	114
5.1 Strains, plasmids and primers used in this study.....	135

LIST OF FIGURES

FIGURE	PAGE
1.1. <i>Pseudomonas aeruginosa</i> bacteria (SEM)	3
1.2. The ESKAPE pathogens	10
1.3. Peptidoglycan recycling and synthesis pathway in <i>E. coli</i>	21
1.4. Outline of cell-wall recycling in <i>P. aeruginosa</i>	30
1.5. Small molecule inhibitors of N-acetyl- β -glucosaminidase NagZ	48
2.1. Muropeptides in recycling.....	61
2.2. The chemical structures of authentic muropeptides used in this study.....	65
2.3. Collision-induced dissociation spectra	66
2.4. Standard curves of synthetic standards, 2e, 4c, 4d, 4e, and 7.....	68
2.5. A Chemical structures of detected muropeptides	70
2.5.B The chemoenzymatic synthesis of six muropeptides	71
2.6. Analysis of <i>P. aeruginosa</i> muropeptides.....	73
2.7. Alignment of PA1085 (PA) and FlgJ (SE) sequence.	75
3.1. Growth curve analysis of mutants	93
3.2. β -lactamase expression of PAOI and permease mutants.	96
3.3.A A brief scheme of the muropeptide extraction protocol.	97
3.3.B The structures of muropeptides	97
3. 4. Relative levels of muropeptides in whole-cells	99
3.5. Relative levels of muropeptides in periplasm	100
3.6. Relative levels of monosaccharides in whole-cell and periplasm	101
3.7. Relative levels of larger muropeptides in whole-cell and periplasm.	102
3.8. Comparison of disaccharide levels in sub-cellular fractions.....	103

4.1. Amino acid sequence alignment of PA1085 with <i>S. enterica</i> FlgJ.....	112
4.2. Flagellar assembly	113
4.3. Swimming motility of PAO Δ <i>flgJ</i> vs PAO1.....	119
4.4. Biofilm formation assay.....	120
4.5. MIC of mutant strain PAO Δ <i>flgJ</i>	121
4.6. N-acetylglucosaminidase activity in whole-cell extracts.....	122
5.1. AmpR regulon.....	132
5.2. Construction of PAO1::P _{<i>ampC</i>} - <i>lux</i>	137
5.3. AmpR fractionates in the membrane.....	140
5.4. Protein models of AmpR mutants.....	141
5.5. Luciferase activity in reporter constructs.....	143
5.6. Optimizing compound concentrations for screening.....	145
5.7. Primary screening of scaffold ranking library.....	146

LIST OF ABBREVIATIONS AND ACRONYMS

AHL	N-acyl Homoserine lactone
AMP	Ampicilin
anhMurNAc	anhydro N-acetyl muramic acid
ANOVA	Analysis of Variance
ATM	Aztreonam
BLAST	Basic local alignment search tool
bp	Base pair
CAZ	Ceftazidime
CEF	Cefepime
CF	Cystic Fibrosis
CFU	Colony Forming Units
CTX	Cefotaxime
DAP	Diaminopimelic acid
DNA	Deoxyribonucleic acid
EDTA	Ethylenediaminetetraacetic acid
ESBL	Extended-spectrum of P-lactamase
et al.	et alia
E-test	Epsilometer test
FOX	Cefoxitin
GlcNAc	N-acetyl glucosamine
h	Hour
HMM PBPs	High Molecular Mass Penicillin Binding Protein

HPLC	High pressure liquid chromatography
HTH	Helix-turn-helix
IMI	Imipenem
IPTG	Isopropyl-D-l-thiogalactopyranoside
LB	Luria Bertani
LC/MS	Liquid chromatography/Mass spectrometry
LTs	Lytic transglycosylases
LTTR	LysR-type transcriptional regulator
MDR	Multi drug resistant
MER	Meropenem
MFS	Major facilitator superfamily
MIC	Minimum inhibitory concentration
ml	Milliliter
mm	Millimeter
mM	Millimolar
4-MUGlcNAc	4-methylumbelliferyl N-acetyl-D Glucosaminide
MurNAc	N-acetyl muramic acid
NaCl	Sodium chloride
NADH	Nicotinamide adenine dinucleotide
nm	nanometer
OD	Optical Density
ORF	Open reading frame
PCR	Polymerase chain reaction
PIP	Piperacillin

PQS	Pseudomonas quinolone signaling
QS	Quorum sensing
RNA	Ribonucleic acid
RND	Resistance nodulation division
T3SS	Type III secretion system
T6SS	Type VI secretion system
UDP	Uridine-Diphosphate
UTI	Urinary Tract Infection
XDR	Extensively drug resistant

CHAPTER 1

Introduction

This chapter has been partly published:

**Cell-wall recycling and synthesis in *Escherichia coli* and
Pseudomonas aeruginosa – their role in the development of resistance**

Dhar S, Kumari H, Balasubramanian D, Mathee K.

J Med Microbiol. 2018 Jan; 67(1):1-21. doi: 10.1099/jmm.0.000636.

1.1. *Pseudomonas aeruginosa*

Pseudomonas aeruginosa is a Gram-negative bacteria of the family Pseudomonadaceae (Kapatral V, 2000). Members of this genus were described the first time by Walter Migula in late 1800 (Palleroni, 2004). The name was coined as “Pseudo” meaning false and “monas” refers to a unit (Palleroni, 2010). The species “*aeruginosa*” means copper rust or green. This alluded to the characteristic appearance of the bacteria in a culture owing to its synthesis of pigments such as pyocyanin and pyoverdinin (Reyes, *et al.*, 1981, Cox & Adams, 1985). This organism is found ubiquitously, meaning in the earth, vegetation, soil, and water. It also has the capacity to survive on surfaces associated with medical devices like catheters and other instrument associated with dialysis (Talsma, 2007).

The ubiquity of these bacteria is due to its non-fastidious nature. It is well-known that *P. aeruginosa* can survive in minimal and versatile nutrition which contribute to the pervasive nature of this organism (Palleroni, 2001). Experiments have verified the presence of these bacteria even in distilled water containing minerals (Favero, *et al.*, 1971, Legnani, *et al.*, 1999). *P. aeruginosa* has been characterized as an obligate aerobe which can grow in anaerobic conditions with nitrate as an alternate electron acceptor (Carlson & Ingraham, 1983, Davies, *et al.*, 1989). It is both catalase and oxidase positive which is a distinguishing feature considered during lab. diagnosis and identification of Pseudomonal infections (Lysenko, 1961).



Figure 1.1. *Pseudomonas aeruginosa* bacteria (SEM). These Gram-negative, rod-shaped bacteria are ubiquitous, often found in humans as part of the normal flora. They are also one of the common causes of hospital-acquired infections. (<https://fineartamerica.com/featured/3-pseudomonas-aeruginosa-bacteria-sem-semsteve-gschmeissner.html>)

The complex mechanisms that lie beneath its virulence are also reflected in its large genome size. The prototypic, lab reference strain of *P. aeruginosa* PAO1 has a genome size of more than 6 million base pairs with 5570 open reading frames (Holloway, 1955). In addition to PAO1, other sequenced strains include Liverpool Epidemic Strain LESB58, PA14, PACS2, C3719, and PA2192 (Cheng, *et al.*, 1996, Lee, *et al.*, 2006, Mathee, *et al.*, 2008, Poirel, *et al.*, 2010). A large set of genes that are conserved among these strains are referred to as the core genes (Mathee, *et al.*, 2008). Besides this, the accessory genome consists of components that include transcriptional regulators, genes encoding for two-component systems and genes regulating/involved in antibiotic resistance as well as the regions of genome plasticity (Mathee, *et al.*, 2008, Klockgether, *et al.*, 2011). Comparative analysis of the different *Pseudomonas* species including *P.*

aeruginosa, *P. syringae*, *P. fluorescens*, *P. stutzeri*, and *P. putida*, also highlight the contribution of horizontal gene transfers and genomic recombination to the versatility and adaptation that is exhibited by this pathogen (Silby, *et al.*, 2011). All of the above enable the bacteria to survive, adapt and flourish under hostile conditions often found in the host, resulting in infections.

Besides the metabolic versatility and minimal nutritional requirements other factors that contribute to the ubiquitous nature of this bacteria as well as make this a formidable pathogen in clinical settings are the arsenal of virulence factors (Gellatly & Hancock, 2013). Some of the common infections include hospital-acquired infections of the lung (Crouch Brewer, *et al.*, 1996, Lyczak, *et al.*, 2000), burn-wound (Estahbanati, *et al.*, 2002, Dale, *et al.*, 2004), urinary tract (Bouza, *et al.*, 2002, Lamas Ferreiro, *et al.*, 2017), and cancer chemotherapy (Vento, *et al.*, 2008). It is also the primary pathogen responsible for morbidity and mortality in cystic fibrosis (CF) (Hoiby, 1974, Marks, 1981, Davies, 2002) chronic keratitis (Dart & Seal, 1988) and otitis media and externa (Seyfried & Fraser, 1978, Yeo, *et al.*, 2007). Two main networks which are often interconnected underlie the severity of these infections; the arsenal of virulence factors and the variegated and numerous resistance mechanisms.

The initial stage of *P. aeruginosa* infection includes the process of bacterial adhesion to a surface followed by its colonization and subsequent invasion (Vasil, 1986). Remaining unchecked this may progress to a systemic infection. The virulence factors that are foundational for a successful infection can be broadly divided into those up-regulated in chronic and others in acute infections stages.

1.2 Virulence in *P. aeruginosa*

Flagella and Type 4 pili: *P. aeruginosa* flagellum and pili serve as a virulence factor providing motility and surface adhesion. Flagella are involved in maintaining swimming motility (Kearns, 2010). The absence of flagellum was found to result in strains that are deficient in acute infection (Feldman, *et al.*, 1998). Along with pili, flagella also maintain swarming movements (Kohler, *et al.*, 2000).

P. aeruginosa has multiple pili located at the polar ends. Both flagella and pili assist in adhesion by binding to receptors asialoGM1 which is expressed on the host epithelium especially upon a tissue breach (Gupta, *et al.*, 1994, Feldman, *et al.*, 1998). Pili is responsible for the third type of movement shown by *P. aeruginosa*; twitching (Bradley, 1980). Flagella and pili are also a significant player in forming biofilms (O'Toole & Kolter, 1998). Due to their role in *P. aeruginosa* pathogenesis, both flagella and pili have been targeted for anti-bacterial activity (Potvin, *et al.*, 2003, Kipnis, *et al.*, 2006).

Alginate: *P. aeruginosa* in presence of a stress such as host-response often turn mucoidy due to the production of an exopolysaccharide known as alginate (Evans & Linker, 1973). This is composed of repeating units of D-mannuronic acid and L-guluronic acid (Remminghorst & Rehm, 2006). This phenotype is predominantly seen in chronic infections especially in CF (Doggett, *et al.*, 1964, Hoiby, 1974). Alginate helps in maintaining bacterial adhesion by preventing phagocytosis and opsonization (Bayer, *et al.*, 1991, Pedersen, 1992). It also enhances the binding of the bacteria to lung epithelium. In addition, elimination of these mucoid strains proves more difficult as this slime-like substance forms an effective barrier against antibiotics. Mucoid strains of *P. aeruginosa* were found to be more resistant to aminoglycoside as well as β -lactams

(Ramsey & Wozniak, 2005). It was presumed that alginate formed the main matrix in biofilms, however that was not the case (Stapper, *et al.*, 2004).

Lipopolysaccharide: The lipopolysaccharide (LPS) is an important immunologic component of *P. aeruginosa* (Pier, 2007). Although a lot of variabilities exists among its structure, its basic components include Lipid A, a core oligosaccharide and O-oligosaccharide or -antigen (King, *et al.*, 2009). O-antigen of the LPS specifies the type of antibody that is produced against the bacteria and is the basis of serotyping (Kaya, *et al.*, 1989). Lipid A is recognized by the cells of the host immune system, such as Toll like receptor 4, which induces the release of cytokines resulting in inflammation (Backhed, *et al.*, 2003, Pier, 2007).

Biofilm: *P. aeruginosa* exists in organized communities wherein they are embedded in a heteropolymer mesh composed of extracellular polysaccharides namely Pel and Psl, protein, DNA with interweaving water channels (Ma, *et al.*, 2012, Jennings, *et al.*, 2015). This is typically found in chronic infections and it increases the severity and tenacity of the infection (Costerton, *et al.*, 1999, Bjarnsholt, 2013). Besides localizing on natural surfaces like respiratory airways, heart valve; biofilms often form on medical devices such as a catheter or stents (Tacconelli, *et al.*, 2009). Infections found in biofilms are more difficult to eradicate resulting often in antibiotic resistance (Hoiby, 1974).

Type 3 secretion system (T3SS): One of the critical regulators of acute infection phenotypes is the T3SS (Hauser, 2009). Activation of this system depends upon host-cell contact and availability of calcium in the extracellular milieu (Frank, 1997, Vallis, *et al.*, 1999). In *P. aeruginosa*, there are 43 genes distributed amongst the five operons that cluster together and a master-regulator ExsA regulates the activity of T3SS (Yahr & Frank, 1994, Frank, 1997). This system is characterized by the production of toxic

effector proteins which are secreted into the host-cytosol through a needle-like appendage similar to the flagellum. It comprises of four major effector proteins including ExoS, ExoT, ExoU, and ExoY (Frank, 1997). Three proteins PopB, PopD, and PcrV form the pore of the host cell membrane and assemble the secretory appendage to translocate the effectors. Effectors ExoS, T, and U prevent endocytosis and phagocytosis as well as disrupt the epithelial barrier of the host tissue (Heimer, *et al.*, 2013, Rangel, *et al.*, 2015). ExoU also increases the release of proinflammatory eicosanoids and is often associated with bacteremia, sepsis and lung damage (McMorran, *et al.*, 2003, Saliba, *et al.*, 2005). ExoY is an adenylate cyclase that increases the intracellular cyclic AMP causing cell necrosis and barrier disruption (Stevens, *et al.*, 2014). Animal models of infections including pneumonia; burn wounds, sepsis and keratitis were shown to be worsened in the presence of an active T3SS (Finck-Barbancon, *et al.*, 1997, Sawa, *et al.*, 1998, Lee, *et al.*, 2003, Koh, *et al.*, 2005).

Quorum Sensing (QS): As the name suggests, a process that depends upon the formation of a “quorum”; a minimum number of bacterial cells (Nealson & Hastings, 1979). In other words, it is dependent on cell-signaling that is active once a certain cell density has been reached. The cell-signaling is facilitated through the synthesis and secretion of small-molecules known as “quorumones”, which often have an acyl-homoserine backbone (Parsek, *et al.*, 1999). Quorum sensing in *P. aeruginosa* was classically known to involve two main players, the Las and Rhl-associated genes (Koch, *et al.*, 1991, Gambello, *et al.*, 1993, Ochsner, *et al.*, 1994, Pearson, *et al.*, 1995). In addition, there are two other systems namely the Pseudomonas quinolone system (PQS) and the relatively recently identified IQS (Pesci, *et al.*, 1999, Lee, *et al.*, 2013). Earlier studies show these systems are arranged in a hierarchy with the Las system at the top. However, more recent studies have suggested that the Rhl system may also be

regulating the Las genes under certain conditions (Dekimpe & Deziel, 2009). The IQS system is known to be functional only under phosphate starvation (Lee, *et al.*, 2013). All the systems regulate virulence factors that can overwhelm the immune system of the host resulting in infection.

QS is involved in the production of pigments known as pyocyanin (Dietrich, *et al.*, 2006). This is a phenazine compound that helps the bacteria to establish an infection in a CF patient's lungs (Kong, *et al.*, 2006, Caldwell, *et al.*, 2009, Carlsson, *et al.*, 2011). It can also act as an antimicrobial due to its production of superoxide radicals (Hassett, *et al.*, 1992). Another pigment produced by *P. aeruginosa* is pyoverdine, a siderophore (Stintzi, *et al.*, 1998). Iron is one of the critical components essential for maintaining proper cellular physiology and growth (Ochsner, *et al.*, 2002). Siderophores are iron-chelators which transport extracellular iron to the cell-surface receptors and make it easily available to the bacteria (Visca, *et al.*, 2007).

Besides the pigments, QS is also involved in regulating other virulence factors such as the production of a staphylolytic protease known as LasA, as well as elastase (LasB) production (Kessler, *et al.*, 1993, Whiteley, *et al.*, 1999). Both LasA and LasB are proteases which cause tissue invasion and have immune-modulatory properties (Kharazmi, 1989, Hobden, 2002). In addition, QS regulates the production of bacterial surfactants known as the rhamnolipids which play a prominent role in interfering with host-immune responses during an infection (Alhede, *et al.*, 2009). These bio-surfactants prevent phagocytosis as well clearance of bacteria from the epithelial surface by impairing ciliary beat (Read, *et al.*, 1992). Furthermore, motility and biofilm formation, which are under the influence of multiple genetic networks and environmental cues, are

also regulated by QS (Kohler, *et al.*, 2000, Davey, *et al.*, 2003, Patriquin, *et al.*, 2008, Solano, *et al.*, 2014).

1.3 Antibiotic resistance in *P. aeruginosa*

Supporting the arsenal of virulence factors, *P. aeruginosa* infections are largely intractable due to the various mechanisms of resistance shown by this pathogen. Most commonly used antibiotic therapies include a combination of newer generation cephalosporins with aminoglycosides (Driscoll, *et al.*, 2007, Kanj & Kanafani, 2011). Despite this combination therapy, some infections remain unmanageable resulting in physicians resorting to the use of older antibiotics such as the polypeptide colistin which had previously been discontinued due to its nephro- and neurotoxic adverse events (Falagas & Kasiakou, 2005). *P. aeruginosa* is listed as a pathogen of a serious threat (Level 2) by the US Center for Disease Control and Prevention as it causes 51,000 infections per year; of which 6,700 are multi-drug resistance with 440 deaths (CDC, 2013). Furthermore, carbapenem-resistant *P. aeruginosa* is also one of the three bacterial species listed by the World Health Organization as a pathogen of critical priority (World Health Organization, 2017). This bacterium is also one of the ESKAPE (*Enterococcus faecium*, *Staphylococcus aureus*, *Klebsiella pneumoniae*, *Cinetobacter baumannii*, *P. aeruginosa* and *Enterobacter species*) pathogens with growing multi-drug resistance (Figure 1.2.) (Rice, 2008).

The main mechanisms conferring resistance includes an impermeable outer membrane, expression of efflux pumps, alteration of drug target proteins and the production of hydrolytic enzymes.

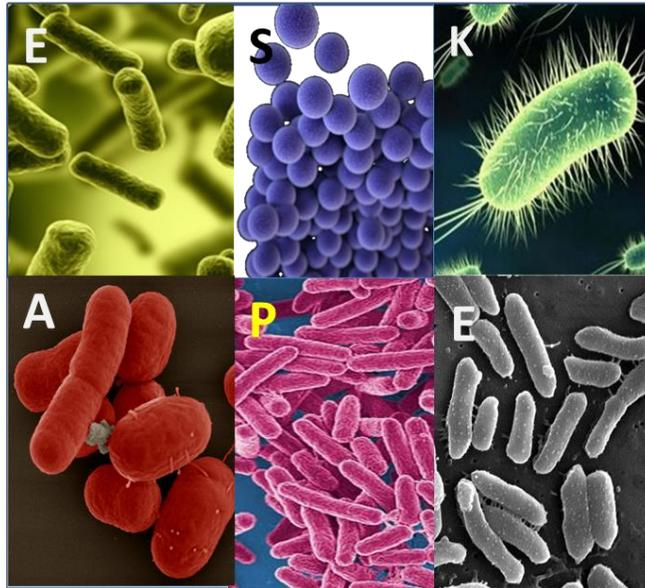

Figure 1. 2. The ESKAPE pathogens. These include a group of pathogens that show multi-drug resistance (MDR). It includes: **E**-*Enterococcus faecium*, **S**- *Staphylococcus aureus*, **K**- *Klebsiella pneumoniae*, **A**-*Acinetobacter baumannii*, **P**- *Pseudomonas aeruginosa*, **E**-*Enterobacter* species.

Figure adapted from: <http://www.bacteriainphotos.com/>

1.3.1 Permeability barriers

The outer membrane found in Gram-negative organisms forms the first line of defense against host-immune stimuli as well as from antibiotics. Most of the antibiotic targets are located in the cytoplasm of the bacteria and in order to reach the site of action, the antibiotics must first cross the outer membrane. Movement of small-molecules across this barrier is facilitated by the presence of multiple channels located on the outer-membrane called as porin proteins.

Porin protein: The major porin found in *P. aeruginosa* is OprF (Hancock, *et al.*, 1979, Nikaido, *et al.*, 1991). Despite its abundance in the outer membrane, the intake of small molecules through this porin is far lesser when compared to OmpF, the major porin

found in *E. coli*, (Yoshimura, *et al.*, 1983). It has been shown that OprF has an open and a closed conformation (Sugawara, *et al.*, 2006, Li, *et al.*, 2012). At most times, a small number of the porin channels are open which accounts for the decreased permeability of *P. aeruginosa* to small molecules (Yoshimura & Nikaido, 1982). Despite this, OprF is one of the most significant players' regulating small molecule uptake into *P. aeruginosa* (Nicas & Hancock, 1983). Depletion of OprF from the outer membrane gives rise to increased resistance for fluoroquinolones and certain β -lactams such as ceftazidime and carbenicillin. However, the overall effect on resistance is often minimized due to the loss of membrane integrity in OprF mutants which creates an increased permeability to small molecules (Gotoh, *et al.*, 1989). In addition to its role in antibiotic resistance, OprF has been found to be required for the pathogenesis of *P. aeruginosa* PAO1 and PA14 through modulation of quorum sensing and T3SS phenotypes (Fito-Boncompte, *et al.*, 2011).

Another resistance determining factor in the outer-membrane is the OprD porin in *P. aeruginosa* (Li, *et al.*, 2012). Its absence is most commonly associated with the advent of carbapenem resistance. The identification of this porin is hence linked with the discovery of resistance to imipenem, which is considered as the last line of defense against resistant-pseudomonal infections. Besides carbapenems, OprD also transports basic amino acids such as arginine, lysine, and histidine as well as peptides (Trias & Nikaido, 1990). Nutrient media containing these specific amino acids was found to increase the minimal inhibitory concentration (MIC) of *P. aeruginosa* to carbapenems (Ochs, *et al.*, 1999). This may be a concern in clinical settings wherein the presence of basic amino acids in human serum is not accounted for and hence the MIC obtained in vitro may not be truly reflective of the bacterial MIC in the patient's infection site. In the lab, it has been found that OprD expression can be increased when bacteria are grown

with these amino acids as the sole source of carbon or nitrogen (Muramatsu, *et al.*, 2003). The presence of trace metals like zinc and copper in the media causes down-regulation of this channel (Perron, *et al.*, 2004).

1.3.2 Efflux-mediated resistance

Another mechanism which is often found to act in synergy with an impermeable outer membrane is the expression of efflux pumps (Lambert, 2002). The efflux pumps are a predominant factor regulating antibiotic resistance and have been considered as good targets for novel antibiotics (Schweizer, 2003). The resistance-regulating efflux pumps found in Gram-negative bacteria including *P. aeruginosa* belong to the resistance nodulation-division (RND) family (Schweizer, 2003, Apel & Surette, 2008). Structurally, these pumps can be divided into three major components wherein a channel is found on the outer membrane that is dependent on a proton motive force, an adaptor protein seen in the periplasmic area and an inner membrane transporter which captures and transports solutes from the cytoplasm to the extracellular milieu (Blair & Piddock, 2009, Venter, *et al.*, 2015).

P. aeruginosa has twelve efflux pumps which have been characterized. These include MexAB-OprM (Li, *et al.*, 1995) and MeXY-OprM (Mine, *et al.*, 1999), MexCD-OprJ (Gotoh, *et al.*, 1998), MexEF-OprN (Kohler, *et al.*, 1997), MexJK (ChuanChuen, *et al.*, 2002), MexGHI-OpmD (Aendekerk, *et al.*, 2002), MexVW (Li, *et al.*, 2003), MexPQ-OpmE (Mima, *et al.*, 2005), MexMN (Mima, *et al.*, 2005), TriABC (Mima, *et al.*, 2007), MuxAB-OpmB (Mima, *et al.*, 2009) and CzrAB-OpmN (Hassan, *et al.*, 1999). These efflux pumps have a broad and varied range of antibiotic substrates MexAB-OprM can

expel the β -lactams including the antipseudomonal penicillins, the monobactams, cephalosporins such as ceftazidime and cefotaxime as well as selected carbapenems such as meropenem and the β -lactamase inhibitors as well as fluoroquinolones and aminoglycosides (Li, *et al.*, 1995, Srikumar, *et al.*, 1998, Srikumar, *et al.*, 2000). Amongst the β -lactams, mostly the fourth generation of cephalosporins is transported by the MexCD-OprJ efflux pumps (Poole, *et al.*, 1996). MexAB participates in regulating intrinsic resistance for *P. aeruginosa* whereas MexCD does not (Kohler, *et al.*, 1996, Poole, *et al.*, 1996). Carbapenems and cephalosporins are also transported by MexEF-OprN (Kohler, *et al.*, 1996, Kohler, *et al.*, 1997). Fluoroquinolones can act as a substrate for most of the efflux pumps. Aminoglycosides such as gentamicin, amikacin, and tobramycin are the substrates of specifically MexXY-OprM (Poole, *et al.*, 1996). It has been found that strains which exhibit multi-drug resistance often show overexpression of these pumps (Poole, *et al.*, 1996, Oh, *et al.*, 2003).

1.3.3 Target modification.

The sites of action of the β -lactams are the penicillin-binding proteins which are enzymes essential for the peptidoglycan (PG) synthesis. The PG of bacteria is composed of two sugar units, *N*-acetyl glucosamine, and *N*-acetyl muramic acid. A five amino acid peptide chain composed of L-alanine, γ -D-glutamic acid, meso-diaminopimelic acid (meso-DAP), and D-alanyl-D-alanine is attached to the muramic acid (Heilmann, 1972, Heilmann, 1974). The penicillin-binding proteins catalyze an essential step in the formation of the cell-wall by acting as a transpeptidase and facilitate the cross-linking of the glycan chain between the third amino acid of one to the fourth amino-acid of another. The β -lactams act by binding covalently to the active site of the PBPs to form acyl-enzyme complexes (Wise & Park, 1965, Bycroft & Shute, 1985).

Mutations occurring in this active site hence prevent the binding of the antibiotic to the enzyme. Besides specific mutation of the PBP that incapacitates drug-binding, the deletion of PBP4 was shown to result in high level expression of *ampC* resulting in β -lactam resistance in a clinical setting (Moya, *et al.*, 2009). These specific mutants were also isolated from clinically resistant strains (Moya, *et al.*, 2009). Decreased binding of β -lactam to PBP3 has been reported in *P. aeruginosa* treated for a long duration with tobramycin and antipseudomonal β -lactam (Godfrey, *et al.*, 1981).

1.3.4 β -lactamase mediated resistance.

These are hydrolytic enzymes that target the β -lactam antibiotics. These enzymes were first identified for their role even before the global widespread of the first β -lactam i.e. penicillin (Abraham & Chain, 1988). Given the diversity of the enzymes, they have been classified several times depending on their hydrolytic properties or substrate profile as well as any structural homology between the enzymes. Notable classifications amongst these include the scheme proposed by Richmond and Sykes who divided the Gram-negative enzymes into five major groups according to their substrate profile (Richmond & Sykes, 1973). This was extended by Sykes and Matthew to include the plasmid-encoded enzymes (Sykes & Matthew, 1976). Mitsuhashi and Inoue also categorized the enzymes according to their substrate profiles and included very specific hydrolytic activity such as those targeting a specific generation of cephalosporins (Mitsuhashi S, 1981). Two of the currently employed classifications are those by Ambler and Bush. Bush modified and expanded the classification provided by Richmond and Sykes to include sub-groups for the enzymes based on substrates and inhibitor profile (Bush & Singer, 1989, Bush, *et al.*, 1995). The other classification scheme that is in use currently was proposed by Ambler and divides the enzymes into four groups A, B, C and

D according to the conserved sequences amongst the amino acids (Ambler, 1980). Enzymes belonging to A, C, and D classes have a serine in the active site and act by serine ester hydrolysis. Class B enzymes are also called metallo- β -lactamases and require a zinc ion in the active site for their activity (Nambu, *et al.*, 1999).

Class A Enzymes: These enzymes are commonly plasmid-borne or encoded in the integron region with a minority of them being encoded on the chromosome (Matthew, 1979, Medeiros, 1997). The enzymes in this class are commonly known as penicillinases and demonstrate a broad substrate profile with respect to their hydrolytic properties (Matthew, 1979). The common groups of enzymes include TEM, SHV, PER, CTX-M, IMI, SME, GES, and VEB (Datta & Kontomichalou, 1965, Matthew, *et al.*, 1979, Nordmann, *et al.*, 1993, Poirel, *et al.*, 2000, Karim, *et al.*, 2001, Zhao & Hu, 2010, Fairfax, *et al.*, 2011). β -lactamase inhibitors such as tazobactam, sulbactam, clavulanic acid, and relebactam have been found to inhibit their enzyme activities (Weldhagen, *et al.*, 2003). TEM and its derivatives have been identified in Gram-negative pathogens including *E. coli*, *K. pneumoniae*, *H. influenzae* and *N. gonorrhoea* (Ambler, 1980). Another common enzyme found in this class is the SHV. These are structurally homologous with TEM. Both TEM and SHV confer resistance to the synthetic and semi-synthetic penicillins such as ampicillin, amoxicillin, ticarcillin, and carbenicillin as well as the narrow-spectrum cephalosporins (Livermore, 1995, Tzouveleki & Bonomo, 1999). Derivatives of these enzymes such as the TEM-1, TEM-2, and SHV-1 show extended spectrum providing resistance to 2nd and 3rd generation cephalosporins as well as monobactams (Weldhagen, *et al.*, 2003). *P. aeruginosa* has derivatives TEM 21, 24 42 and 4 along with SHV 2, 12 and 5 (Weldhagen, *et al.*, 2003). In addition, clinical isolates with GES and its related IBC, VEB, and PER and their derivatives have also been recognized. The affinity is similar to TEM and SHV; they inhibit all the groups of β -

lactams including penicillins, cephalosporins, imipenem (Weldhagen, *et al.*, 2003). In addition, GES-1 can also inhibit clavulanic acid, imipenem and as well as cefoxitin- a third generation cephalosporin (Poirel, *et al.*, 2000). PER1- which has 20% amino acid identity with TEM and SHV also inhibits the monobactam (Bouthors, *et al.*, 1998).

Class B Enzymes: Instead of a serine moiety in the active site, this enzyme class requires a zinc (Zn^{+2}) ion (Dufresne, *et al.*, 1988, Palzkill, 2013). These enzymes are mainly expressed and transmitted through integrons in plasmids or transposons in pathogenic bacteria such as Enterobacteriaceae and *P. aeruginosa* (Palzkill, 2013). *P. aeruginosa* contains the IMP, VIM, SPM and GIM type of enzymes (Watanabe, *et al.*, 1991, Lauretti, *et al.*, 1999, Toleman, *et al.*, 2002, Castanheira, *et al.*, 2004). The IMP-, VIM-, and GIM-type enzymes are encoded within mobilizable units such as the plasmids and the transposons (Poirel, *et al.*, 2000, Castanheira, *et al.*, 2004, Brizio, *et al.*, 2006). SPM-1 is closely associated with a genetic element known as ISCR (IS Common Region) that is related to the spread of antibiotic resistance (Toleman, *et al.*, 2002). The enzymes in this class can degrade all the β -lactams except for aztreonam (Sacha, *et al.*, 2008). Furthermore, these enzymes are also resistant to the β -lactamase inhibitors (Sacha, *et al.*, 2008). There is a considerable homology between these enzymes and their derivatives. VIM derivative, VIM-1 shows less than 30% identity with the IMP-1 type enzymes whereas the SPM-1 shows 35.5% identity to IMP-1 (Lauretti, *et al.*, 1999). GIM-1 also shows a high conservation with the IMP-1 enzyme (42%), and slightly lesser with VIM-1 and SPM-1 (28-30%) (Castanheira, *et al.*, 2004).

Class C Enzymes: These enzymes are mainly chromosomal however plasmid-encoded forms have been detected (Papanicolaou, *et al.*, 1990, Bauernfeind, *et al.*, 1996, Walther-Rasmussen & Hoiby, 2002). In *P. aeruginosa* two chromosomal class C β -

lactamases have been identified, AmpC and PIB-1 (Fajardo, *et al.*, 2014). Overexpression of PIB-1 was found to confer resistance to carbapenems whereas AmpC overexpression led to increased resistance for all the groups of β -lactams (Fajardo, *et al.*, 2014). The regulation of AmpC expression and its influence on β -lactam resistance is enumerated in detail later in the introduction.

Class D Enzymes: This group of enzymes is commonly known as oxacillinases owing to their ability to hydrolyze oxacillin, methicillin, cloxacillin, and dicloxacillin (Dale & Smith, 1972). One of the recently identified enzymes in this group is PoxB, previously known as OXA-50 (Girlich, *et al.*, 2004, Kong, *et al.*, 2005). This enzyme is encoded in the chromosome and was found to have carbapenemase activity (Zincke, *et al.*, 2016). In the presence of the primary chromosomally encoded β -lactamase AmpC, the effect of this enzyme on resistance is minimal. However, upon overexpression, this was found to render resistance to carbapenems. This effect was especially pronounced in the absence of the porin for carbapenems, OprD (Zincke, *et al.*, 2016). The β -lactamase inhibitors (-bactam) do not inhibit this class of enzymes (Payne, *et al.*, 1994). Other than this specific chromosomal β -lactamase, several plasmids encoded class D-enzymes has also been characterized. Some of these in *P. aeruginosa* are OXA-2 and its variants (-15, -36), -5, -6,-10 and its variants (OXA-11,-14,-16,-17 and -19), and -20 (Danel, *et al.*, 1995, Danel, *et al.*, 1998, Mugnier, *et al.*, 1998, Danel, *et al.*, 1999, Poirel, *et al.*, 2010). Additionally, another enzyme LCR-1 is also found which includes penicillin in its spectrum (Yang & Bush, 1995).

1.4 Regulation of AmpC β -lactamase expression.

The expression of AmpC β -lactamase is inducible in many bacteria including *P. aeruginosa* (Lodge, *et al.*, 1990). The study of AmpC regulation was first demonstrated

in *E. coli* using *C. freundii* AmpR (Lindberg & Normark, 1987). The connection of β -lactamase induction with recycling was realized after demonstrating that particular genes which participate in recycling also affected β -lactamase induction (Wiedemann, *et al.*, 1998). This specific induction phenomenon was found to occur only in the presence of β -lactams, which led to an accumulation of muropeptides. As studied in Enterobacteriaceae, besides AmpR, other players that are required in this process include AmpG, AmpD, AmpDh2, AmpDh3, NagZ among others (Wiedemann, *et al.*, 1998). As this process, has not been investigated in *P. aeruginosa* the next few sections entail the details of this process in this pathogen and compares it to the model organism that was used to study recycling- *E. coli*.

1.5 Cell-wall recycling and synthesis in *Escherichia coli* and *P. aeruginosa*

The cell-wall is an essential component of bacterial architecture that confers cell shape, prevents lysis under fluctuating internal turgor pressure, and protects from external assaults, thus enabling their ubiquitous existence. The cell-wall is composed of tightly cross-linked peptidoglycan (PG) which encircles the inner membrane and forms a protective layer known as the murein sacculus (Weidel & Pelzer, 1964). The murein sacculus varies in size and chemical content in distinct species. In Gram-negatives such as *E. coli*, the cell-wall is approximately six nanometers (nm), whereas in the Gram-positives it may span up to 80 nm providing the capacity to withstand higher amounts of turgor pressure (Whatmore & Reed, 1990, Matias, *et al.*, 2003, Matias & Beveridge, 2007). Extensive remodeling of the cell-wall occurs during bacterial cell growth and division. Thus, recycling of the cell-wall components is critical to conserve resources. Both Gram-positive and -negative bacteria recycle almost 40-50% of the cell-wall components (Goodell, 1985, Doyle, *et al.*, 1988). Cell-wall recycling and synthesis are

tightly coordinated to preserve bacterial integrity. Since the survival of bacteria critically depends on their PG-based cell-walls, it is a selective target of many antibiotics. Hence, the development of antibiotic resistance in bacteria is intimately tied in with the cell-wall synthesis and recycling (Jacobs, *et al.*, 1994). Both these processes have been studied in *Citrobacter freundii*, *Enterobacter cloacae*, and *E. coli* and to some extent in *P. aeruginosa* (Jacobs, *et al.*, 1994, Jacobs, *et al.*, 1997, Lee, *et al.*, 2016, Lee, *et al.*, 2016).

P. aeruginosa infections are a serious clinical challenge due to their multiple antibiotic resistances and aggressive virulence mechanisms and its ability to establish persistent chronic infections. A dearth of antibiotics to treat multi-drug resistance threatens to cast the world back into a pre-antibiotic era (Davies & Davies, 2010). *P. aeruginosa* shows both intrinsic as well as acquired resistance towards multiple classes of antibiotics (Lambert, 2002, Lister, *et al.*, 2009). Intrinsic resistance to a widely used group of drugs, the β -lactams, is often conferred through the inducible β -lactamase AmpC, a process which interweaves with the cell-wall recycling pathway (Normark, 1995). Despite the discovery of cell-wall recycling in *E. coli* in the 1980's, technical limitations have hindered its full characterization in other organisms.

This review provides a brief overview of *de novo* cell-wall biosynthesis and focuses on what is known to date regarding cell-wall recycling in *E. coli* and *P. aeruginosa*. We discuss the roles of the genes involved in cell-wall synthesis and recycling in conferring resistance to both β -lactam and non β -lactam antibiotics. The review also focuses on the global regulator AmpR that connects cell-wall recycling to other resistance mechanisms through its diverse regulatory role in *P. aeruginosa* (Balasubramanian, *et al.*, 2012, Kumari, *et al.*, 2014).

1.5.1 Cell-wall biochemistry

The bacterial murein sacculus is composed of a heteropolysaccharide of *N*-acetyl muramic acid (MurNAc) and *N*-acetyl-glucosamine (GlcNAc) linked by β -1 \rightarrow 4 glycosidic linkages, with a short chain peptide containing up to five amino acids, attached to the muramyl moiety (Salton, 1953, Perkins, 1963, Schleifer & Kandler, 1972). The full-length pentapeptide side chain in Gram-negative bacteria is typically composed of L-Alanine- γ -D-Glutamate-*meso*-diaminopimelic acid-D-Alanyl-D-Alanine (L-Ala- γ -D-Glu-m-DAP-D-Ala-D-Ala) (Glauner, *et al.*, 1988). Cross-linking in Gram-negative bacteria between two adjacent peptide chains commonly occurs between the 3rd residue of one chain (*m*-DAP) and the 4th residue (D-Ala) of the other (Schleifer & Kandler, 1972, Sauvage, *et al.*, 2008). High-performance liquid chromatography analysis of purified murein sacculus has shown that the extent of crosslinking is comparable between *E. coli* and *P. aeruginosa* (Quintela, *et al.*, 1995). This crosslinking creates a mesh-like structure, which confers murein sacculus the strength to withstand internal pressure.

The PG in many Gram-negatives including *E. coli* and *P. aeruginosa* has linked proteins known as Braun's lipoprotein (Braun & Rehn, 1969, Braun & Sieglin, 1970, Quintela, *et al.*, 1995). The covalent linkage of this lipoprotein between the outer membrane and the murein sacculus contributes further to the stability of the cell-wall. There is a considerable variation in the thickness of the murein sacculus amongst Gram-negative bacteria. For instance, the PG thickness of *E. coli* is 6.35 ± 0.53 nm whereas *P. aeruginosa* is at 2.41 ± 0.54 nm (Matias, *et al.*, 2003). Despite the variations found in the details of the structural architecture in the Gram-negatives, the cell-wall is highly conserved across bacteria promoting its use as a valuable antibiotic target.

1.5.2 Cell-wall biosynthesis

The biosynthesis of the cell-wall can be divided into three phases based on the localization of the processes; namely, those occurring in the cytoplasm, the inner leaflet of the cytoplasmic membrane, and the periplasm (Figure 1.3).

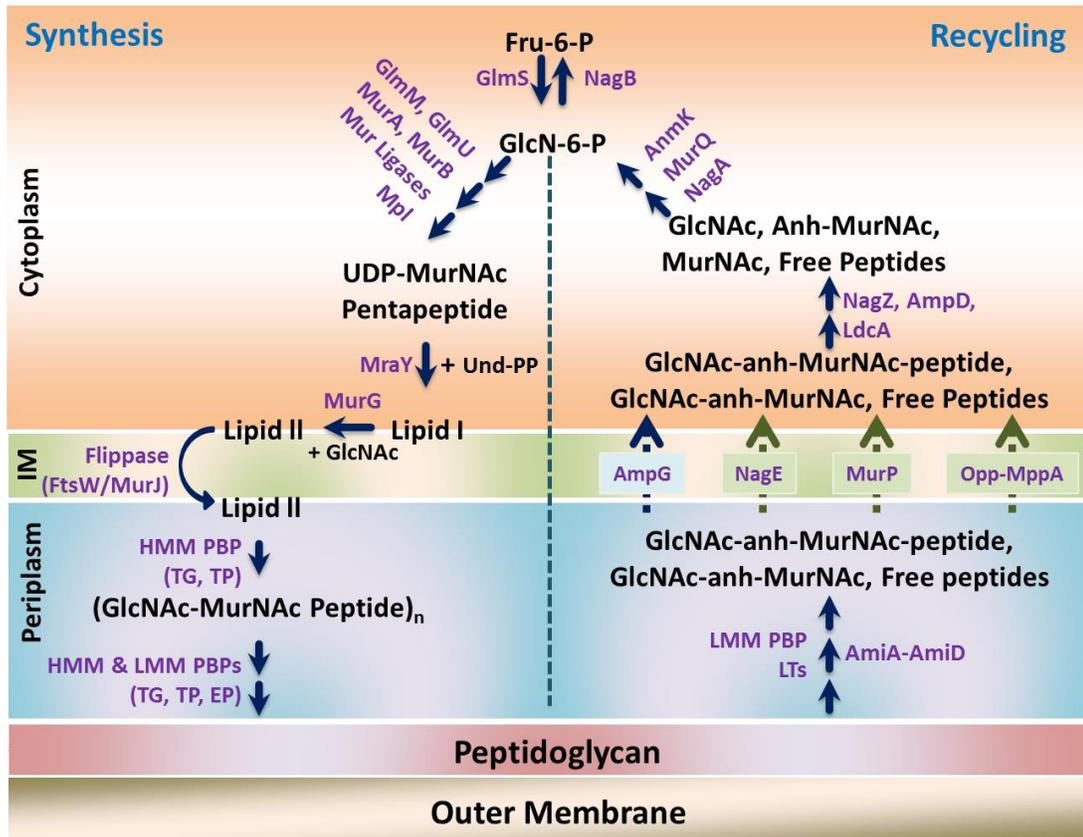

Figure 1.3. Peptidoglycan recycling and synthesis pathway in *E. coli*. The major cell-wall recycling enzymes found in the periplasm include the low molecular mass penicillin binding proteins (LMM PBPs: PBP4, PBP5, PBP6, PBP7/8), amidases (AmiA-AmiD), and the lytic transglycosylases (LT: MltA, MltB, MltC, MltD, MltE, MltF, MltG, and Slt70). The major products formed are the N-acetylglucosamine-1, 6-anhydro-N-acetylmuramyl-peptides (GlcNAc-anhMurNAc-peptide) along with GlcNAc-anhMurNAc and free peptides. These mucopeptides are translocated from the periplasm into the cytoplasm, mainly through a permease AmpG. Some of the mucopeptides are also translocated through the OppBCDF complex with mucopeptide-binding protein MppA, as well as through NagE and MurP. Once in the cytoplasm, these mucopeptides are processed by β -N-acetylglucosaminidase (NagZ) and the N-acetyl-anhydromuramyl-L-alanine amidase (AmpD) and an LD-carboxypeptidase (LdcA). The products are then acted upon by a kinase (AnmK), an etherase (MurQ), and a deacetylase (NagA) to form

glucosamine-6-phosphate (GlcN-6-P). The recycling and biosynthesis pathways converge at this point. GlcN-6-P is converted back to fructose-6-phosphate (Fru-6-P) through a deaminase (NagB).

In the PG biosynthesis pathway, Fru-6-P is converted to GlcN-6-P through an amidotransferase (GlmS). The GlcN-6-P undergoes a series of modifications through a hexosephosphate mutase (GlmM), an uridylyltransferase (GlmU), an enolpyruvyl transferase (MurA), a reductase (MurB) and the Mur ligases (MurC, MurD, MurE, MurF) to form the uridine-diphosphate (UDP) MurNAc-pentapeptides. In addition to the Mur ligases is the murein peptide ligase (Mpl) which can catalyze the ligation of tri-, tetra- and pentapeptides to MurNAc. A translocase (MraY) transfers the UDP-MurNAc peptide onto an undecaprenyl-pyrophosphate (UND-PP) group to form Lipid I which anchors the complex to the inner membrane (IM). A glycosyltransferase (MurG) catalyzes the attachment of GlcNAc to form lipid II. Lipid II is then flipped from the cytoplasm into the periplasm using “flippase” (FtsW and MurJ). Once in the periplasmic space, the high molecular mass penicillin binding proteins (HMM PBPs) with transglycosylase (TG) and transpeptidase (TP) activities polymerize and cross-link the muropeptides with the existing peptidoglycan (PG). LMM PBPs with endopeptidase (EP) activity cleave the existing PG layer, facilitating the insertion of new glycan strands.

Escherichia coli

Cytoplasm

Fructose-6-phosphate is converted to uridine-diphosphate (UDP)-GlcNAc through series of steps driven by the activities of the GlmS, GlmM, and GlmU (Badet, *et al.*, 1987, Mengin-Lecreulx & van Heijenoort, 1994, Mengin-Lecreulx & van Heijenoort, 1996). UDP-GlcNAc is further converted to UDP-MurNAc pentapeptide by the activity of the Mur group of enzymes (MurA, MurB, MurC-MurF ligases) (Benson, *et al.*, 1993, Barreteau, *et al.*, 2008). To this pentapeptide, a 55-C aliphatic chain called undecaprenyl pyrophosphate is attached by MraY (Bouhss, *et al.*, 2004). This aliphatic moiety is attached to the inner face of the cytoplasmic membrane to form Lipid I (Chatterjee & Park, 1964, Anderson, *et al.*, 1965).

Inner membrane

MurG catalyzes the addition of GlcNAc to the MurNAc moiety of Lipid I to yield Lipid II (Mengin-Lecreulx, *et al.*, 1991, Barreteau, *et al.*, 2008). The Lipid II is flipped over into

the periplasmic space using a 'flippase' enzyme (Pomorski & Menon, 2006). The identity of "flippase" remains ambiguous and is the subject of current research (Meeske, *et al.*, 2015, Ruiz, 2015, Elhenawy, *et al.*, 2016). In *E. coli*, FtsW and MurJ have been independently shown to be the proteins responsible for translocation of the lipid-linked muropeptides from the cytoplasm into the periplasmic space (Ruiz, 2008, Mohammadi, *et al.*, 2011, Sham, *et al.*, 2014, Leclercq, *et al.*, 2017). Furthermore, in *E. coli* the transport and subsequent polymerization of Lipid II by FtsW is regulated via PBP1B and PBP3 (Leclercq, *et al.*, 2017).

Periplasm

The final steps of the PG synthesis involve the incorporation of the GlcNAc-MurNAc pentapeptide component of Lipid II into the rapidly evolving murein sacculus. High molecular mass penicillin binding proteins (HMM PBPs) with a transglycosylase domain (PBP1A, PBP1B, and PBP1C) facilitate the link between the MurNAc end of the Lipid II with the GlcNAc of the existing strand (Ishino, *et al.*, 1980, Suzuki, *et al.*, 1980, Tamura, *et al.*, 1980, Nakagawa, *et al.*, 1984, Schiffer & Holtje, 1999, Terrak, *et al.*, 1999). HMM PBPs with a transpeptidase domain (PBP1A, PBP1B, PBP1C, PBP2 and PBP3) catalyze the formation of cross-links between two peptide chains (Ishino, *et al.*, 1980, Nakamura, *et al.*, 1983, Asoh, *et al.*, 1986, Goffin & Ghuyssen, 1998, Nguyen-Disteche, *et al.*, 1998) (Table 1.1). Cross-linking is composed of two steps wherein the terminal D-Ala-D-Ala of the peptide chain attached to MurNAc is cleaved with the release of one alanine (Izaki, *et al.*, 1966). The murein tetrapeptide so formed is known as the "donor" peptide. Subsequently, the terminal D-alanine of the tetrapeptide attaches to the *meso*-diaminopimelic acid of an "acceptor" peptide chain (Izaki, *et al.*, 1966).

Pseudomonas aeruginosa

Bioinformatics analyses suggest the presence of *E. coli* homologs in *P. aeruginosa*; however, the enzymatic characterization of many of the proteins is yet to be done (Table 1.1).

Cytoplasm

Sequence comparison reveals homologs of GlmM (PA4749), GlmS (PA5549) and GlmU (PA5552) that aids in the synthesis of UDP-GlcNAc from fructose-6-phosphate (Table 1.1). In *P. aeruginosa* glucosamine-6-phosphate synthetase GlmS is under the regulation of a repressor GlmR (PA5550) (Ramos-Aires, *et al.*, 2004). A transcriptional factor NagR regulates both GlmS and GlmU in *E. coli*, highlighting the difference in regulation of PG saccharide GlcNAc between the two organisms (Plumbridge, 1995). In addition to protein homology, the functional activity of GlmM as a phosphoglucosamine mutase in *P. aeruginosa* has also been established (Tavares, *et al.*, 2000). Homologs of the Mur enzymes that lead to the formation of UDP-MurNAc pentapeptide from UDP-GlcNAc namely an enolpyruvyl transferase MurA (PA4450), a reductase MurB (PA2977), as well as the Mur ligases, MurC (PA4411), MurD (PA4414), MurE (PA4417), and MurF (PA4416) are also encoded in the *P. aeruginosa* genome (Table 1.1). The activity of the *P. aeruginosa* Mur enzymes was analyzed by providing the initial substrate for MurA, UDP-GlcNAc, and detecting the formation of the final product UDP-MurNAc-pentapeptide (El Zoeiby, *et al.*, 2001). The enzymatic properties of all the Mur ligases of *P. aeruginosa* were also heterologously characterized in *E. coli* (El Zoeiby, *et al.*, 2000, Azzolina, *et al.*, 2001). *P. aeruginosa* also encodes a homolog of Mpl ligase (PA4020) which facilitates ligation of tri-, tetra- and pentapeptides to UDP-MurNAc (Table 1.1). The cytosolic translocase MraY (PA4415) then transfers the UDP-MurNAc pentapeptide to

an undecaprenol carrier group that anchors the muropeptide to the inner membrane (Table 1.1) (Azzolina & El-Sherbeini, 2002). *P. aeruginosa* has homologs of inner membrane glycosyltransferase MurG (PA4412) and flippases FtsW (PA4413) and MviN (PA4562) (Table 1.1). A crystal structure of *P. aeruginosa* MurG has been solved in complex with its substrate, UDP-GlcNAc (Brown, *et al.*, 2013).

Periplasm

The periplasmic cell-wall synthesis enzymes for polymerization and cross-linking of the muropeptides include the HMM PBPs, namely PBP1A (PA5045), PBP1B (PA4700), PBP2 (PA4003), and PBP3 (PA4418) (Table 1.1) (Noguchi, *et al.*, 1979, Handfield, *et al.*, 1997, Legaree, *et al.*, 2007, Chen, *et al.*, 2017). By sequence homology to *E. coli*, PBP1A (PA5045) and 1B (PA4700) contain both transglycosylase and transpeptidase domains whereas PBP2 (PA4003), and PBP3 (PA4418) have the domain for transpeptidase activity (Finn, *et al.*, 2016, Marchler-Bauer, *et al.*, 2017). In addition, *P. aeruginosa* also contains an additional transpeptidase, PBP3B/3X (PA2272), which is not found in *E. coli* (Liao & Hancock, 1997). *P. aeruginosa* PBP3 and 3B expression differ temporally, the former being upregulated during the exponential and the latter during stationary growth-phase (Liao & Hancock, 1997).

Table 1.1. List of genes involved in cell-wall synthesis

Proteins	Genes		Protein Homology (%)		Functional Annotation
	<i>E. coli</i>	<i>P. aeruginosa</i>	Identity *	Similarity †	
Periplasm					
PBP1a	<i>ponA/mrcA</i>	PA5045	41	58	Transglycosylase and transpeptidase
PBP1B	<i>ponB/mrcB</i>	PA4700	38	56	Transglycosylase and transpeptidase
PBP1C	<i>pbpC</i>	NF	-	-	Transglycosylase and transpeptidase
MgtA	<i>mgtA</i>	PA0378	48	65	Transglycosylase
PBP2	<i>pbpA/mrdA</i>	PA4003	43	61	Transpeptidase
PBP3	<i>ftsI/pbpB</i>	PA4418	43	60	Transpeptidation. Important for septa formation during cell-division
PBP3b	NF	PA2272	-	-	Transpeptidase
PBP4	<i>dacB</i>	PA3047	26	40	D-alanyl-D-alanine carboxypeptidase and endopeptidase
PBP5	<i>dacA</i>	PA3999	46	62	DD-carboxypeptidase
PBP6	<i>dacC</i>	PA3999	46	65	DD-carboxypeptidase
PBP6b	<i>dacD</i>	NF	-	-	DD-carboxypeptidase
PBP7	<i>pbpG</i>	PA0869	63	75	DD-carboxypeptidase and endopeptidase
Inner membrane					
FtsW	<i>ftsW</i>	PA4413	39	55	Flippase (Putative)
MurJ	<i>murJ</i>	PA4562	75	88	Flippase (Putative)
MurG	<i>murG</i>	PA4412	45	62	UDP-N-acetylglucosamine-N-acetylmuramyl-pentapeptide transferase
Cytoplasm					
MraY	<i>mraY</i>	PA4415	67	81	N-acetylmuramyl-pentapeptide-transferase
GlmM	<i>glmM</i>	PA4749	60	74	Phosphoglucosamine mutase
GlmU	<i>glmU</i>	PA5552	56	71	Glucosamine-1-phosphate acetyltransferase, N-acetylglucosamine-1-phosphate

					uridyltransferase
MurA	<i>murA</i>	<i>PA4450</i>	60	74	Enolpyruvyl transferase
MurB	<i>murB</i>	<i>PA2977</i>	42	56	UDP-N-acetyl pyruvylglucosamine reductase
MurC	<i>murC</i>	<i>PA4411</i>	58	73	UDP-N- acetylmuramate L- alanine ligase
MurD	<i>murD</i>	<i>PA4414</i>	50	63	UDP-N-acetylmuramyl L-alanine-D-glutamate ligase
MurE	<i>murE</i>	<i>PA4417</i>	47	58	UDP-N-acetylmuramyl L-alanyl-D-glutamate- diaminopimelate ligase
MurF	<i>murF</i>	<i>PA4416</i>	46	60	UDP-N-acetylmuramy L-alanyl-D-glutamyl- diaminopimelate-D- alanyl-D-alanine ligase
Mpl	<i>mpl</i>	<i>PA4020</i>	59	72	Murein peptide ligase
GlmS	<i>glmS</i>	<i>PA5549</i>	63	79	Glucosamine-6- phosphate synthase

The data is compiled from EcoCyc and *Pseudomonas* Genome database website (Keseler, *et al.*, 2009, Winsor, *et al.*, 2016).

* The value for protein sequence identity and similarity of *E. coli* and *P. aeruginosa* was obtained using ClustalW2 "pairwise sequence alignments".

NF: Not Found

1.5.3 Peptidoglycan growth

To ensure bacterial growth (elongation and division) while maintaining cellular integrity, both PG degradative enzymes such as low molecular mass penicillin binding proteins (LMM PBP), lytic transglycosylases (LT), and amidases and PG synthase enzymes such as HMM PBPs must perform in a coordinated fashion along with the various bacterial cytoskeletal elements to avoid cell lysis (Typas, *et al.*, 2011). The growth of the murein sacculus has been studied extensively in *E. coli* by Park *et al*

(Burman, *et al.*, 1983, Park & Burman, 1985). Using radioactively-labelled PG they demonstrated that newly formed PG strands are cross-linked with the existing strand at multiple sites. At the same time, the cross-links in the existing murein strand are degraded by endopeptidases (Burman, *et al.*, 1983). A three-for-one growth model suggests that the existing strand acts as a dock that incorporates three newly synthesized murein chains (Holtje, 1998). The soluble PG fragments that are generated during this progressive replacement of the existing murein with the new strand are recycled (Goodell & Schwarz, 1985).

1.5.4 Cell-wall recycling

As the cells divide, the walls break and rejoin at every cycle, thus generating muropeptides of varying lengths. Gram-positives such as *Bacillus sp.*, *Lactobacillus acidophilus* release close to 25-30% of their muropeptides into the culture media (Mauck, *et al.*, 1971, Boothby, *et al.*, 1973, Doyle, *et al.*, 1988). Only 6-8% extracellular muropeptides were detected for *E. coli* (Goodell & Schwarz, 1985). The latter finding gave rise to the hypothesis that the Gram-negatives recycle their muropeptides. The hypothesis was confirmed by the detection of tritiated-DAP reuse by the bacteria during cell growth (Goodell, 1985). Extensive studies in *E. coli* have provided the knowledge on cell-wall recycling in Gram-negatives (Park & Uehara, 2008) (Figure 1. 4). Though *P. aeruginosa* harbors the orthologous genes, their functional roles remain to be elucidated (Kong, *et al.*, 2010) (Table 1.2). This following section compares cell-wall recycling in Gram-negative *E. coli* and *P. aeruginosa*. The pathway is broken down into processes

occurring in the subcellular compartments; namely the periplasm, inner membrane, and cytoplasm (Figure 1.4).

Periplasm

Mainly, three types of lytic enzymes are found in the periplasmic space that creates the muropeptide intermediates (Figure 1.3, 1. 4). These include the LTs, the LMM PBPs and the amidases (Park & Uehara, 2008, van Heijenoort, 2011).

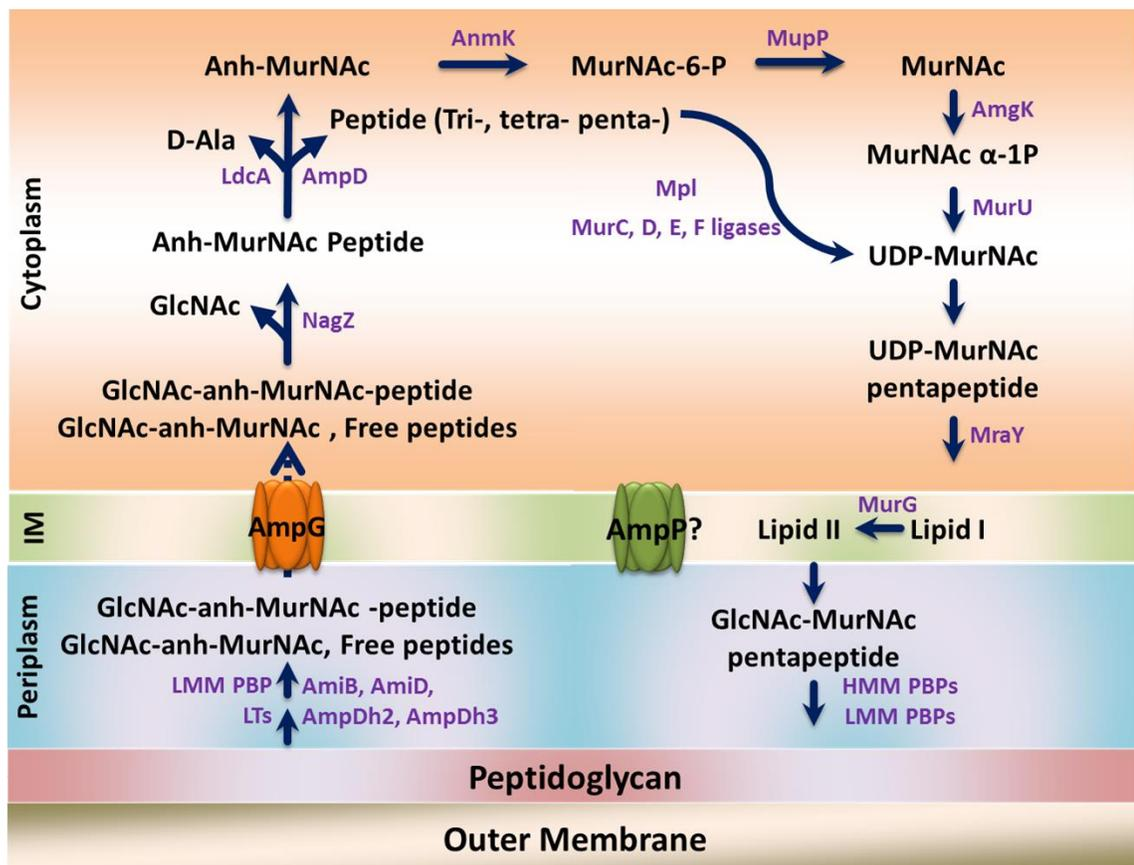

Figure 1. 4 Outline of cell-wall recycling in *P. aeruginosa*. Muropeptides formed in the periplasm through low molecular mass penicillin binding proteins (LMM PBPs: PBP4,

PBP, PBP6, PBP7/8), amidases (AmiB, AmiD, AmpDh2 and AmpDh3), and the lytic transglycosylases (LT: MltA, MltB, MltD, MltF, MltF2, MltG, Slt, SltB2, SltH/SltB, and RlpA) are internalized into the cytoplasm through a permease AmpG. AmpP is a paralog of AmpG found in *P. aeruginosa* whose function in cell-wall recycling has not been elucidated yet. Muropeptides imported by AmpG are subsequently degraded by a β -N-acetylglucosaminidase (NagZ) which removes the GlcNAc moiety. The product N-acetyl-anhydro muramic acid (anh-MurNAc) peptide is processed by an N-acetyl-anhydromuramyl-L-alanine amidase (AmpD) which cleaves the peptide chain; and a LD-carboxypeptidase (LdcA) that removes the terminal amino acid D-alanine (D-Ala) from a tetrapeptide. In *P. aeruginosa*, anh-MurNAc is reutilized and converted to MurNAc-6-phosphate (MurNAc-6-P) by a kinase (AnmK). MurNAc-6-P is then converted to MurNAc by a phosphatase (MupP). Following this, an anomeric MurNAc/GlcNAc kinase (AmgK) catalyzes the formation of MurNAc- α -1-phosphate; to which an uridylyl transferase attaches a uridine-diphosphate (UDP) to facilitate the formation of UDP-MurNAc. AmgK, MupP, and MurU cell-wall recycling enzymes are found exclusively in *P. aeruginosa*. Following the formation of UDP-MurNAc, the peptide chain is added by a murein peptide ligase (Mpl) or by Mur ligases (MurC, MurD, MurE and MurF). The UDP-MurNAc pentapeptide is converted to Lipid I (undecaprenol-pyrophosphate-UDP-MurNAc peptide) by a MurNAc-pentapeptide translocase (MraY) and a glycosyltransferase (MurG) then attaches the GlcNAc moiety to form Lipid II (undecaprenol-pyrophosphate-UDP-GlcNAc-MurNAc peptide). Lipid II is flipped into the periplasm through putative “flippases” (FtsW and MurJ). The GlcNAc-MurNAc peptide is reincorporated into the growing PG through high molecular mass (HMM) and LMM PBPs.

Lytic transglycosylases (LTs)

The LTs act on the murein sacculus to release their signature product GlcNAc 1, 6 anhydro MurNAc (Holtje, *et al.*, 1975) (Figure 1.4). The LTs facilitate PG remodeling, insertion of membrane-associated structures such as flagella and the secretion systems, and help in cell separation during division (Heidrich, *et al.*, 2002, Koraimann, 2003, Scheurwater, *et al.*, 2008). Investigation of the *E. coli* ORFs led to the identification of eight genes encoding LTs; *mltA*, *mltB*, *mltC*, *mltD*, *mltE* (*emtA*), *mltF*, *mltG* and *slt70* (Holtje, *et al.*, 1975, Engel, *et al.*, 1992, Romeis, *et al.*, 1993, Dijkstra & Keck, 1996, Kraft, *et al.*, 1998, Lee, *et al.*, 2013, Yunck, *et al.*, 2016). The enzymatic activities of all the *E. coli* LTs were demonstrated using the murein sacculus isolated from the log and stationary phase as a substrate (Lee, *et al.*, 2013). All the LTs are exolytic and cleave at

a terminus of the PG strand. However, MltE, MltD, MltB, Slt70 (SltY) and MltC are endolytic and cleave in the middle of a PG strand (Lee, *et al.*, 2013). Of these, MltA was reported to have the highest activity on purified murein sacculus. All the enzymes show a higher activity on the murein sacculus isolated during the log phase than the stationary phase. The higher activity is in accordance with the extensive remodeling that occurs at the log phase (Lee, *et al.*, 2013). It may also be due to the structural differences in the sacculus during the phases of bacterial growth as well as the lack of cell division during stationary phase (Glauner, *et al.*, 1988). Deletion analyses demonstrate the presence of extensive functional redundancy within this group of eight genes encoding LTs (Heidrich, *et al.*, 2002). *E. coli* tolerate the loss of up to three LTs, but deletion of all eight leads to cell death (Lommatzsch, *et al.*, 1997, Kraft, *et al.*, 1999, Heidrich, *et al.*, 2002).

The LTs in *P. aeruginosa* were first identified using renaturing PAGE and zymograms (Watt & Clarke, 1994, Li, *et al.*, 1996). A total of 11 LTs, MltA (PA1222), MltB (PA4444), MltD (PA1812), MltF (PA3764), MltF2 (PA2865), MltG (PA2963), Slt (PA3020), SltB2 (PA1171), SltH/SltB3 (PA3992), and RlpA (PA4000) were reported in *P. aeruginosa* (Blackburn & Clarke, 2001, Blackburn & Clarke, 2002, Cavallari, *et al.*, 2013, Jorgenson, *et al.*, 2014, Lee, *et al.*, 2017). A few studies separately enumerate the enzymatic activities of all the lytic transglycosylases (Jorgenson, *et al.*, 2014, Lee, *et al.*, 2016, Lee, *et al.*, 2017). *In vitro* analyses with purified enzymes demonstrated that all the *P. aeruginosa* LTs have both endolytic and exolytic activity. MltD, MltF2, RlpA, and Slt exhibited higher endolytic activity whereas MltA, SltB1, SltB2, and SltB3 had higher exolytic activity. The most and least active enzymes are SltB1 and MltF2, respectively. Some of these enzymes exhibit substrate preference — MltB specifically requires a peptide chain on the muropeptide to demonstrate its lytic activity whereas RlpA acts on

the degradation products of amidases, namely GlcNAc-anhMurNAc without the attached peptide chains (Jorgenson, *et al.*, 2014, Lee, *et al.*, 2017) (Figure 1.4).

Low molecular mass penicillin binding proteins (LMM PBPs)

The LMM PBPs act mostly as endopeptidases and or carboxypeptidases (Goffin & Ghuysen, 1998, Sauvage, *et al.*, 2008, Vollmer, *et al.*, 2008). The endopeptidase activity of PBPs leads to hydrolysis of the cross-bridge between *m*-DAP and D-Ala, whereas the carboxypeptidases remove the terminal amino acid from a pentapeptide during cross-linking (Strominger, *et al.*, 1967, Sauvage, *et al.*, 2008, Vollmer, *et al.*, 2008).

E. coli have five LMM PBPs, namely PBP4 (DacB), PBP5 (DacA), PBP6 (DacC), PBP6b (DacD) and PBP7/8 (PbpG) (Spratt & Strominger, 1976, Holtje, 1998, Denome, *et al.*, 1999, Kong, *et al.*, 2010) (Table 1.2). PBP4/ DacB is a bifunctional peptidase with both carboxy and endopeptidase activities (Korat, *et al.*, 1991). Together with PBP5 (DacA), PBP4 (DacB) is involved in maintaining normal cell morphology (Korat, *et al.*, 1991, Meberg, *et al.*, 2004, Clarke, *et al.*, 2009). PBP5 (DacA) is found attached to the inner membrane (Spratt, 1977). It is the major carboxypeptidase in *E. coli*; deletion of *dacA* is associated with cell shape defects and a striking increase in some pentapeptides (Matsushashi, *et al.*, 1979, De Pedro, 1980, Nelson & Young, 2000, Nelson & Young, 2001). PBP6/DacC and PBP6b/DacD exhibit carboxypeptidase activities (Tamura, *et al.*, 1976, Amanuma & Strominger, 1980, Baquero, *et al.*, 1996). An increase in expression levels of *dacC* is noted during the stationary phase (van der Linden, *et al.*, 1992).

Another endopeptidase PBP7/PbpG and its proteolytic product PBP8 have been identified in *E. coli* (Henderson, *et al.*, 1995). Loss of *pbpG* did not result in any

morphological aberrations, however, the absence of both *dacA* and *pbpG* encoding PBP5 and PBP7, respectively resulted in increased cell shape defects as compared to the loss of *dacA* alone (Romeis & Holtje, 1994, Meberg, *et al.*, 2004). Expression of *dacA* and *dacC* is regulated by the BolA protein, which is highly conserved in eukaryotes and prokaryotes (Santos, *et al.*, 2002, Guinote, *et al.*, 2011). BolA maintains cell morphology in both a PBP5/PBP6-dependent and -independent manner (Freire, *et al.*, 2009). BolA regulates the carboxypeptidase activities of DacA/PBP5 and DacC/PBP6, and overexpression of *bolA* showed a decreased rate of growth which was lost upon deletion of both *dacA* and *dacC* (Santos, *et al.*, 2002, Guinote, *et al.*, 2011). Overexpression of *bolA* also impaired PBP2-mediated cell elongation and formation of cytoskeleton due to spatial disorganization of MreB (Freire, *et al.*, 2009).

LMM PBPs in *P. aeruginosa* include PBP4/DacB (PA3047), PBP5/DacC (PA3999), and PBP7/PbpG (PA0869) (Noguchi, *et al.*, 1979, Song, *et al.*, 1998, Smith, *et al.*, 2013, Lee, *et al.*, 2015, Ropy, *et al.*, 2015). Loss of *dacC* results in increased pentapeptides establishing its role as the primary carboxypeptidase in *P. aeruginosa* (Noguchi, *et al.*, 1985, Smith, *et al.*, 2013, Ropy, *et al.*, 2015). *P. aeruginosa* encodes a homolog of BolA (PA0857), which shows a 46% identity to their *E. coli* counterpart. However, its role as a regulator of carboxypeptidases in *P. aeruginosa* is yet to be investigated. An additional increase of pentapeptides is also seen upon deletion of *dacB* and *pbpG* confirming the presence of multiple carboxypeptidases (Ropy, *et al.*, 2015). PBP4/DacB and PBP7/PbpG also act as endopeptidases (Song, *et al.*, 1998, Lee, *et al.*, 2015, Ropy, *et al.*, 2015). *P. aeruginosa* appears to not harbor PBP6. However, *P. aeruginosa* PBP5 shares 48% homology with *E. coli* PBP6.

Amidases

The periplasmic amidases remove the amino acid chain from the muramyl moieties of the sacculus as well as from the recycling by-products such as GlcNAc-anhMurNAc peptides (Van Heijenoort & Van Heijenoort, 1971, van Heijenoort, *et al.*, 1975, Tomioka, *et al.*, 1983, Priyadarshini, *et al.*, 2007, Uehara & Park, 2007). *E. coli* expresses four periplasmic enzymes *amiA*, *amiB*, *amiC*, and *amiD* that have N-acetylmuramyl-L-alanine amidase activity (Tomioka, *et al.*, 1983, Tsui, *et al.*, 1994, Heidrich, *et al.*, 2001). AmiA, AmiB, and AmiC have a high sequence homology and assist in cell separation during division (Heidrich, *et al.*, 2001). Loss of these three amidases affected septal formation resulting in a chaining phenotype with aggregates of three to six cells (Heidrich, *et al.*, 2002, Priyadarshini, *et al.*, 2007). The activity of these three enzymes is regulated spatiotemporally by proteins with LytM domains, which have conserved sequences and are collectively known as dLytM factors (Uehara, *et al.*, 2009). EnvC and NlpD are dLytM proteins (Uehara, *et al.*, 2009). EnvC belongs to the divisome group of proteins that participate in cytokinesis and activates AmiA and AmiB, whereas NlpD regulates AmiC activity (Uehara, *et al.*, 2010). AmiD is tethered to the outer membrane and does not contribute to cell separation, and its loss has no effect on the cell-wall morphology (Uehara & Park, 2007, Mercier, *et al.*, 2010). AmiD cleaves at both N-acetylmuramyl and 1, 6 anhydro-N-acetylmuramyl peptides and plays a critical role in generating fragments for recycling (Priyadarshini, *et al.*, 2007, Uehara & Park, 2007, van Heijenoort, 2011). The loss of *amiD* resulted in an accumulation of GlcNAc-anhMurNAc tri- and tetrapeptides (Uehara & Park, 2007).

P. aeruginosa has homologs of periplasmic AmiA (PA5538) and AmiB (PA4947). Both these proteins share homology with their *E. coli* counterparts and have N-acetylmuramyl-L-alanine amidase activity (Scheurwater, *et al.*, 2007). Deletion of *amiA*

exhibited no significant effect on *P. aeruginosa* cell viability or morphology (Yakhnina, *et al.*, 2015). AmiB (PA4947) in contrast to *E. coli* AmiB was found to be essential for *P. aeruginosa* survival (Yakhnina, *et al.*, 2015). *P. aeruginosa* AmiB is required for cell separation during division, as depletion resulted in filamentous growth with a marked deficiency in the invagination of the inner membrane. Additionally, AmiB depletion decreased outer membrane impermeability for which the mechanism is unclear (Yakhnina, *et al.*, 2015). *P. aeruginosa* AmiB requires the presence of additional activator dLytM proteins such as NlpD, NlpS, and EnvC (Yakhnina, *et al.*, 2015).

P. aeruginosa also has two periplasmic amidases AmpDh2 (PA5485) and AmpDh3 (PA0807) that play a critical role in cell-wall recycling (Juan, *et al.*, 2006). Both enzymes have significant homology with *E. coli* AmiD (Table 2). AmpDh2, akin to AmiD is anchored to the outer membrane (Uehara & Park, 2007, Martinez-Caballero, *et al.*, 2013). Both AmpDh2 and AmpDh3 process the peptide chain on the polymeric murein sacculus as well as 1, 6 anhydromuramyl peptides generated through the activities of lytic transglycosylases (Zhang, *et al.*, 2013). The preferred substrate, however, for both these amidases is the murein sacculus (Zhang, *et al.*, 2013). Comparing the activity between these two amidases, AmpDh3 has a higher specific activity on the murein sacculus (Lee, *et al.*, 2013, Martinez-Caballero, *et al.*, 2013, Zhang, *et al.*, 2013). Crystal structures and catalytic activities of all the *P. aeruginosa* cell-wall recycling amidases have been reviewed elsewhere (Rivera, *et al.*, 2016).

Inner membrane

The muropeptides that are generated by the periplasmic enzymes are transported into the cytoplasm via the inner membrane proteins which play an indispensable role in

the recycling process. The inner membrane AmpG permease facilitates the diffusion of muropeptides from the periplasm into the cytoplasm (Park, 1993, Jacobs, *et al.*, 1994) (Figure 1.2). The *ampG* gene was first identified in *Enterobacter cloacae* (Werner, *et al.*, 1985). Since then, it has been found in other members of Enterobacteriaceae including *C. freundii*, *Serratia marcescens*, and *Salmonella* sp. The earliest indications that AmpG may be the primary permease in cell-wall recycling came from Normark's lab during the investigation of its role in β -lactamase expression (Lindquist, *et al.*, 1993). Its role as a permease was confirmed when an *ampG* deletion resulted in the increased release of muropeptide in the media which was rescued upon complementation *in trans* (Jacobs, *et al.*, 1994). The *E. coli* AmpG transports muropeptides that contain the disaccharide units GlcNAc-anhMurNAc across the inner membrane into the cytoplasm (Cheng & Park, 2002). AmpG has 10 transmembrane helices, and *ampG* is the second ORF in a two-gene operon which may be post-transcriptionally regulated (Lindquist, *et al.*, 1993, Chahboune, *et al.*, 2005). Besides AmpG, *E. coli* also has another unique permease system, OppBCDF, which complexes with the muropeptide-binding protein MppA and plays a minor role in PG recycling (Goodell & Higgins, 1987, Park, 1993) (Figure 1.4).

P. aeruginosa harbors two AmpG homologs, PA4393 (AmpG) and PA4218 (AmpP) (Table 1.2) (Cheng, *et al.*, 2000, Kong, *et al.*, 2010). Both AmpG and AmpP are inner membrane permeases with 14 and 10 transmembrane helices, respectively (Kong, *et al.*, 2010). The expression of *ampG* and *ampP* is regulated by the transcriptional regulator AmpR (PA4109) in an inducer (sub-MIC of β -lactam) dependent and independent manner, respectively (Balasubramanian, *et al.*, 2012). Both *ampG* and *ampP* are the second genes in independent two-gene operons (Kong, *et al.*, 2010). An uptake assay using fluorophore-conjugated muropeptides demonstrated that *P. aeruginosa* AmpG

transports any muropeptides containing GlcNAc-1, 6 anhydroMurNAc (Perley-Robertson, *et al.*, 2016). However, the *in vivo* role of both the permeases AmpG and AmpP in muropeptide transport remains to be elucidated. AmpG activity can be inhibited by the proton gradient uncoupler, carbonyl cyanide *m*-chlorophenyl hydrazine, suggesting that its activity is dependent on single proton motive force (Zhang, *et al.*, 2010).

An alternative route of transfer of GlcNAc into the cytoplasm using NagE exists for both *E. coli* and *P. aeruginosa* (Plumbridge, 2009). The NagE phosphotransferase phosphorylates and imports GlcNAc into the cytoplasm, adding to the cytoplasmic pool of GlcNAc-6-P (Plumbridge, 2009). In *E. coli*, the absence of *nagE* resulted in a decrease of 50% of GlcNAc-6-P in the cytoplasm (Plumbridge, 2009). Whether this phosphotransferase plays a prominent role in cell-wall recycling in *P. aeruginosa* is yet to be explored. However, *P. aeruginosa nagE* (PA3761) mutants cannot grow using GlcNAc as the sole carbon source, suggesting a significant role for NagE in GlcNAc uptake (Korgaonkar & Whiteley, 2011). In *E. coli*, the uptake and metabolism of MurNAc are mediated by a specific phosphotransferase MurP (Dahl, *et al.*, 2004). This transporter is required for the growth of this bacterium in the presence of MurNAc as the sole carbon source (Dahl, *et al.*, 2004). MurP has not been identified in *P. aeruginosa*.

Table 1. 2. List of genes involved in cell-wall recycling

Proteins	Genes		Protein Homology (%)		Functional Annotation
	<i>E. coli</i>	<i>P. aeruginosa</i>	Identity*	Similarity*	
Periplasm					
PBP1a	<i>ponA/mrcA</i>	PA5045	41	58	Transglycosylase and transpeptidase
PBP1b	<i>ponB/mrcB</i>	PA4700	38	56	Transglycosylase and transpeptidase

PBP4	<i>dacB</i>	<i>PA3047</i>	26	40	D-alanyl-D-alanine carboxypeptidase and endopeptidase
PBP5	<i>dacA</i>	<i>PA3999</i>	46	62	D-alanyl-D-alanine carboxypeptidase
PBP6	<i>dacC</i>	<i>PA3999</i>	46	65	D-alanyl-D-alanine carboxypeptidase
PBP6b	<i>dacD</i>	NF	-	-	D-alanyl-D-alanine carboxypeptidase
PBP7	<i>pbpG</i>	<i>PA0869</i>	63	75	D-alanyl-D-alanine carboxypeptidase and endopeptidase
Slt70	<i>sltY/slt70</i>	<i>PA3020</i>	32	47	Lytic transglycosylase
MltA	<i>mltA</i>	<i>PA1222</i>	30	44	Lytic transglycosylase
MltB	<i>mltB</i>	<i>PA4444</i>	66	78	Membrane-bound lytic murein transglycosylase B
SltB1	NF	<i>PA4001</i>	-	-	Soluble lytic transglycosylase B
MltC	<i>mltC</i>	<i>PA3020</i>	13	20	Lytic transglycosylase
MltD	<i>mltD</i>	<i>PA1812</i>	33	50	Lytic transglycosylase
MltF	<i>mltF</i>	<i>PA3764</i>	33	50	Lytic transglycosylase
MltE	<i>mltE</i>	NF	-	-	Lytic transglycosylase
RlpA	<i>rlpA</i>	<i>PA4000</i>	27	40	Septal ring protein, transglycolytic activity
SltG	NF	<i>PA1171</i>	-	-	Lytic transglycosylase
MltF2	NF	<i>PA2865</i>	-	-	Lytic transglycosylase
SltH	NF	<i>PA3992</i>	-	-	Lytic transglycosylase
AmiA	<i>amiA</i>	<i>PA5538</i>	28	40	N-acetylmuramoyl-L-alanine amidase
AmiB	<i>amiB</i>	<i>PA4947</i>	34	47	N-acetylmuramoyl-L-alanine amidase
AmiC	<i>amiC</i>	<i>PA5538</i>	40	56	N-acetylmuramoyl-L-alanine amidase
AmiC	<i>amiC</i>	<i>PA4947</i>	35	47	N-acetylmuramoyl-L-alanine amidase
AmiD	<i>amiD</i>	<i>PA5485</i>	41	56	N-acetylmuramoyl-L-alanine amidase activity

AmiD	<i>amiD</i>	<i>PA0807</i>	39	50	N-acetylmuramoyl-L-alanine amidase activity
BglX	<i>bglX</i>	<i>PA1726</i>	62	79	Beta-glucosidase
FlgJ	<i>flgJ</i>	<i>PA1085</i>	31	46	Flagellum-specific glucosaminidase
Inner membrane					
AmpG	<i>ampG</i>	<i>PA4393</i>	22	35	Muropeptide permease
AmpG	<i>ampP</i>	<i>PA4218</i>	22	35	Putative muropeptide permease
OppB	<i>oppB</i>	<i>PA4503</i>	35	56	Muropeptide transporter
OppC	<i>oppC</i>	<i>PA1808</i>	24	41	Muropeptide transporter
OppC	<i>oppC</i>	<i>PA2060</i>	23	42	Muropeptide transporter
OppD	<i>oppD</i>	NF	-	-	Muropeptide transporter
OppF	<i>oppF</i>	NF	-	-	Muropeptide transporter
MppA	<i>mppA</i>	NF	-	-	Periplasmic binding component of muropeptide- Opp transporter
MurP	<i>murP</i>	NF	-	-	Anhydro-N-acetylmuramic acid permease
NagE	<i>nagE</i>	<i>PA3761</i>	41	55	N-acetylglucosamine phosphotransferase
Cytoplasm					
NagZ	<i>nagZ</i>	<i>PA3005</i>	50	63	β -N-acetyl-D-glucosaminidase
AmpD	<i>ampD</i>	<i>PA4522</i>	57	69	N-acetylmuramyl-L-alanine amidase
LdcA	<i>ldcA</i>	<i>PA5198</i>	29	40	L, D-carboxypeptidase
AnmK	<i>anmK</i>	<i>PA0666</i>	49	64	Anhydro-N-acetylmuramic acid kinase
MurQ	<i>murQ</i>	NF	-	-	MurNAc-6-P etherase
AmgK	NF	<i>PA0596</i>	-	-	MurNAc kinase
MupP	NF	<i>PA3172</i>	-	-	Phosphatase
MurU	NF	<i>PA0597</i>	-	-	Nucleotidyltransferase
NagA	<i>nagA</i>	<i>PA3758</i>	30	47	GlcNAc and anhMurNAc

					deactylase
Mpl	<i>mpl</i>	<i>PA4020</i>	59	72	Murein peptide ligase
NagB	<i>nagB</i>	NF	-	-	Deaminase

The data is compiled from EcoCyc and *Pseudomonas* Genome database website (Keseler, *et al.*, 2009, Winsor, *et al.*, 2016).

‡ The value for protein sequence identity and similarity of *E. coli* and *P. aeruginosa* was obtained using ClustalW2 “pairwise sequence alignments”.

NF: Not Found

Cytoplasm

Once in the cytoplasm, the mucopeptides are processed by various enzymes to form Lipid II composed of UDP-GlcNAcMurNac pentapeptide attached to a hydrophobic undecaprenol-pyrophosphate group (Mengin-Lecreux, *et al.*, 1991, Bouhss, *et al.*, 2004). Lipid II is flipped across the cytoplasmic membrane into the periplasmic space, where GlcNAcMurNac pentapeptide is reincorporated into the growing cell-wall. There is an overlap between the enzymes mediating these reactions in *E. coli* and *P. aeruginosa*; however, certain enzymes remain unique to each bacterial system. These enzymes are detailed below.

NagZ

In the cytoplasm, the β -N-acetylglucosaminidase NagZ processes the mucopeptides (Yem & Wu, 1976) (Figure 1. 4). The enzymatic activity of NagZ was first identified in *E. coli* K-12 mutant strains which showed a deficiency in β -N-acetylglucosaminidase (Yem & Wu, 1976). The mutation was mapped to *ycfO* that was renamed as *nagZ* following functional characterization of the protein (Yem & Wu, 1976, Yem & Wu, 1976, Hrebenda, 1979). NagZ cleaves the bond between GlcNAc and 1,6 anhydroMurNac, leading to the

formation of independent units of GlcNAc, and 1,6 anhMurNAc-peptide (Yem & Wu, 1976). Deletion of the *nagZ* gene results in the accumulation of GlcNAc-anhMurNAc peptides (Yem & Wu, 1976, Votsch & Templin, 2000). Bioinformatics analyses of *nagZ* sequences led to its identification in numerous Gram-negative pathogens such as *Klebsiella pneumonia*, *Vibrio cholera*, *P. aeruginosa*, *Haemophilus influenza*, and *Bordetella pertussis* among others (Cheng, *et al.*, 2000).

P. aeruginosa nagZ (PA3005) is predicted as the first gene in a two-gene operon along with PA3004, which encodes a phosphorylase. Similar to *E. coli*, NagZ (PA3005) was demonstrated to act as a β -*N*-acetylglucosaminidase (Stubbs, *et al.*, 2008). Crystal structures of NagZ were solved along with its ligand. Using X-ray structures and molecular dynamics simulation, the enzymatic details of NagZ activity was elucidated (Acebron, *et al.*, 2017). Most of the studies with NagZ (PA3005) have been done on its role in regulating antibiotic resistance which will be discussed in the following sections.

AmpD and LdcA

E. coli AmpD cleaves the peptide chain exclusively attached to the 1, 6 anhydromuramyl moieties (Holtje, *et al.*, 1994, Jacobs, *et al.*, 1995). The first indication that this gene may play a critical role in cell-wall recycling stemmed from observations of its influence on β -lactamase induction (Tuomanen, *et al.*, 1991). Its specific role as an amidase in recycling was confirmed when it was noticed that the loss of *ampD* resulted in the accumulation of GlcNAc-anhMurNAc with peptide chains (Holtje, *et al.*, 1994, Jacobs, *et al.*, 1995). Subsequently, a major increase of anhydromuramyl tripeptides in *ampD* deficient *E. coli* cells led to the identification of an LD-carboxypeptidase LdcA (Templin, *et al.*, 1999). This enzyme removes the terminal D-alanine from the muramyl-

tetrapeptides, thereby creating the tripeptides (Templin, *et al.*, 1999). To this tripeptide, MurF attaches a dipeptide D-alanyl-D-alanine (D-Ala-D-Ala) forming a pentapeptide that participates in cross-linking (Uehara & Park, 2007). The loss of *ldcA* results in the formation of GlcNAc-MurNAc-tetrapeptides as the donor muropeptide, which is incapable of cross-linking as it does not contain the terminal D-Ala-D-Ala moiety. This deficient PG backbone eventually leads to cell lysis during the stationary phase of growth (Templin, *et al.*, 1999).

P. aeruginosa also harbors an AmpD homolog (PA4522) (Table 1.2). The enzymatic activity of purified *P. aeruginosa* AmpD was demonstrated using synthetic muramyl and 1, 6 anhydromuramyl derivatives (Zhang, *et al.*, 2013). AmpD activity was higher with the 1, 6 anhydromuropeptides as substrates as opposed to the muramyl derivatives (Zhang, *et al.*, 2013, Rivera, *et al.*, 2016). The cytoplasmic LD-carboxypeptidase in *P. aeruginosa* (PA5198) was also identified as a functional equivalent of *E. coli* LdcA (Korza & Bochtler, 2005).

In the final steps of recycling processes, the PG sugars, GlcNAc, MurNAc, anhMurNAc, and the PG peptides L-Ala- γ -D-Glu-*meso*-DAP-D-Ala-D-Ala rejoin the PG biosynthesis pathway in the cytoplasm.

1.5.5 Convergence of recycling and biosynthesis

The recovery of PG intermediates and its convergence into the biosynthesis pathway is a widely conserved process in bacteria and demonstrates their efficiency in preserving critical energy resources. The muropeptides generated in the cytoplasm through the activities of NagZ, AmpD, and LdcA rejoin the biosynthesis pathway through the

sequential activity of AnmK, MurQ, NagA, and NagB in *E. coli* (White & Pasternak, 1967, Calcagno, *et al.*, 1984, Uehara, *et al.*, 2005, Uehara, *et al.*, 2006) (Figure 1.4).

In *E. coli*, AnmK kinase phosphorylates anhMurNAc to MurNAc-6-P which is processed by MurQ etherase to form GlcNAc-6-P (Uehara, *et al.*, 2005). GlcNAc generated in the cytoplasm after the NagZ activity is phosphorylated to GlcNAc-6-P by NagK (Uehara & Park, 2004). NagA deacetylates GlcNAc-6-P to GlcN-6-P (Park, 2001, Uehara, *et al.*, 2006). GlcN-6-P undergoes deamination by NagB to form fructose-6-phosphate, the initial substrate for glycolysis, PG and lipopolysaccharide synthesis (Calcagno, *et al.*, 1984). GlcN-6-P can also be converted to GlcN α -1P by GlmM which is an intermediate in the PG synthesis pathway (Mengin-Lecreulx & van Heijenoort, 1996) (Figure 1.4).

The set of enzymes for the reutilization of the PG sugars GlcNAc and MurNAc differ among *P. aeruginosa* and *E. coli* (Figure 1.4). In *P. aeruginosa*, an AnmK homolog PA0666 phosphorylates anhMurNAc to form MurNAc-6-P; subsequently, the phosphate is removed by MupP (PA3172) resulting in MurNAc (Bacik, *et al.*, 2011, Borisova, *et al.*, 2014, Borisova, *et al.*, 2017, Fumeaux & Bernhardt, 2017). MurNAc is further processed by two enzymes AmgK (PA0596) and MurU (PA0597) unique to Pseudomonads encoded in the same operon (Gisin, *et al.*, 2013). AmgK (PA0596) converts MurNAc to MurNAc α -1P (Borisova, *et al.*, 2014). A uridylyltransferase MurU (PA0597) acts on MurNAc α -1P to form UDP-MurNAc (Gisin, *et al.*, 2013). The presence of these two proteins bypasses the need for MurQ, NagA (PA3758), NagB, NagK, GlmM (PA4749) and GlmS (PA5549) that are otherwise required for the synthesis of UDP-MurNAc in *E. coli* (Figure 1.4). This novel alternate pathway was identified in *P. aeruginosa* and *P.*

putida (Gisin, *et al.*, 2013, Borisova, *et al.*, 2014). Homologs of AmgK and MurU have been identified in Proteobacteria but not in Enterobacteria (Borisova, *et al.*, 2014).

AmpD amidase cleaves the peptide side chain from UDP-MurNAc resulting in the formation of free tri-, tetra-, and pentapeptides (L-Ala- γ -D-Glu-*meso*-DAP-D-Ala-D-Ala) (Holtje, *et al.*, 1994). LdcA carboxypeptidase cleaves the terminal D-alanine from a tetrapeptide resulting in tripeptides (Templin, *et al.*, 1999). In *E. coli*, murein peptide ligase (Mpl) recycles the tri-, tetra- and pentapeptides by ligating them to UDP-MurNAc formed in the PG biosynthesis pathway (Mengin-Lecreux, *et al.*, 1996, Herve, *et al.*, 2007). Another enzyme, MurF can also ligate dipeptide D-Ala-D-Ala formed by an ATP-dependent ligase Ddl, to a UDP-MurNAc tripeptide to form UDP-MurNAc pentapeptide (Duncan, *et al.*, 1990, Zawadzke, *et al.*, 1991, al-Bar, *et al.*, 1992). Homologs of Mpl (PA4020) and MurF (PA4416) and Ddl (PA4201/PA4410) are found in *P. aeruginosa*; however, their role in cell-wall recycling has not been elucidated.

The tripeptide, L-Ala- γ -D-Glu-*m*-DAP, can be broken down into individual amino acids. The *E. coli* MpaA amidase removes the *meso*-DAP from L-Ala-D-Glu (Uehara & Park, 2003). *E. coli* YcjG epimerizes D-glutamate to L-glutamate forming L-Ala-L-Glu, which is hydrolyzed to individual amino acids by PepD (Schroeder, *et al.*, 1994, Schmidt, *et al.*, 2001). This pathway of amino acid degradation has not been studied in *P. aeruginosa* and bioinformatics analyses of the protein sequences of MpaA, YcjG, and PepD revealed no homologs in the *P. aeruginosa* PAO1 strain.

1.6 Cell-wall recycling and antibiotic resistance

Resistance is a distinctive quality of pathogens that have ensured the long tug of war between the discovery of novel antibiotics and bacterial survival. Antibiotics act at several checkpoints in the bacterial life cycle such as DNA replication, RNA, protein

synthesis and activity as well as cell-wall biogenesis and recycling (Kohanski, *et al.*, 2010). Being unique to bacteria, cell-wall synthesis and recycling are often the targets for many widely-used antibiotics such as β -lactams, fosfomycin, and glycopeptides (Bush, 2012). Consequently, the components of cell-wall recycling process play a key role in the development of resistance to the targeting antibiotics. Through a complex network of regulators, some of the cell-wall recycling components are also involved in the elaboration of cross-resistance to other classes of antibiotics such as fluoroquinolones, aminoglycosides, and macrolides (Kumari, *et al.*, 2014). Here, we describe the role of cell-wall components in promoting antibiotic resistance in Gram-negative bacteria, focusing on *P. aeruginosa*.

1.6.1 β -Lactam resistance involving Amp pathway

β -lactams are the one of the earliest discovered and most commonly administered antibiotics worldwide. The β -lactams act by disrupting the cell-wall synthesis in bacteria (Tipper & Strominger, 1965). Specifically, β -lactam antibiotics mimic the terminal D-Ala-D-Ala residues of the amino acid side chains that serve as the substrates for the transpeptidase domains of HMM PBP's such as PBP1A, PBP1B, PBP2 and PBP3, locking them into an inactive state, thereby preventing PG cross-linking leading to cell lysis and death (Tipper & Strominger, 1965, Zemelman, *et al.*, 1987). Thus, it is not surprising that with the intracellular activation of *ampC*, encoding a β -lactamase, the expression is tightly coordinated with the cell-wall recycling process in Gram-negative bacteria (Wiedemann, *et al.*, 1998, Zeng & Lin, 2013). The AmpR-AmpC system has been investigated thoroughly in Enterobacteriaceae. In many members of the Enterobacteriaceae, the induction of *ampC* expression in response to β -lactam

antibiotics is triggered through the activation of a transcriptional regulator AmpR by the cell-wall degradation products (Lindberg & Normark, 1987, Lindquist, *et al.*, 1989, Tolg, *et al.*, 1993, Wiedemann, *et al.*, 1998, Dik, *et al.*, 2017). The induction of *ampC* by AmpR also requires the products of *ampG*, *ampD*, *ampDh2*, *ampDh3*, and *nagZ*, all of which are involved in PG recycling, as described in previous sections. Studies from the Mathee lab suggest that the AmpR-AmpC (PA4109-PA4110) system might operate differently in *P. aeruginosa* (Balasubramanian, *et al.*, 2015). Expression of the genes *ampG*, *ampP*, *ampD*, *ampDh2*, *ampDh3*, and *nagZ* in *P. aeruginosa* are differentially regulated by AmpR in the presence and absence of β -lactam (Balasubramanian, *et al.*, 2012). AmpG is the permease that transports PG degradation products from the periplasm to cytoplasm. In *Enterobacteriaceae* members, an *ampG* mutant is unable to recycle PG and loses the ability to induce *ampC* expression (Korfmann & Sanders, 1989, Jacobs, *et al.*, 1994) (Table 1.3). Inactivation of *ampG* can restore susceptibility to β -lactams even in pan-resistant *P. aeruginosa* clinical isolates (Zamorano, *et al.*, 2011). *P. aeruginosa* also has an additional AmpG homolog known as AmpP (PA4218), both of which are presumed to be involved in *ampC* induction (Kong, *et al.*, 2010, Zhang, *et al.*, 2010).

The AmpD amidase was identified as being important for β -lactamase induction in *C. freundii* and *Enterobacter cloacae* (Lindquist, *et al.*, 1989). The absence of *ampD* leads to the accumulation of an_hMurNAc-tripeptide in the cytosol and constitutive overproduction of β -lactamase even in the absence of induction, resulting in a high resistance to β -lactams (Jacobs, *et al.*, 1995). The most common mechanism for constitutive *ampC* overexpression in clinical strains leading to β -lactam resistance in *Enterobacteriaceae*, as well as *P. aeruginosa*, is to mutate *ampD* (Langae, *et al.*, 2000, Juan, *et al.*, 2005, Kaneko, *et al.*, 2005, Babouee Flury, *et al.*, 2016) (Table 1.3). *P. aeruginosa* has three different AmpD homologs, AmpD (PA4522), AmpDh2 (PA5485),

and AmpDh3 (PA0807) that are responsible for de-repression of *ampC* expression in a step-wise manner (Juan, *et al.*, 2006, Schmidtke & Hanson, 2008). Deletion of all three *ampD* genes results in increased resistance due to complete de-repression of *ampC* expression resulting in very high MIC for the β -lactams drugs including cephalosporins and monobactams (Juan, *et al.*, 2006, Moya, *et al.*, 2008).

NagZ is a β -*N*-acetylglucosaminidase that removes GlcNAc to generate the 1, 6-anhydromuropeptides, the putative activators of AmpR that are required for the induction of *ampC* (Asgarali, *et al.*, 2009). Mutations in *nagZ* result in low levels of *ampC* expression that enhances the susceptibility to β -lactam antibiotics (Asgarali, *et al.*, 2009, Zamorano, *et al.*, 2010). Deletion of *nagZ* also reversed the resistance due to *ampC* hyper-expression in *ampD* and *dacB* mutants (Zamorano, *et al.*, 2010). Based upon these findings, to increase the bacterial susceptibility to β -lactams, small molecule inhibitors *gluco-nagstain*, LOGNAc, and PUGNAc which are analogous to the NagZ substrates that have oxocarbenium-like transition states have been synthesized (Figure 1.5) (Stubbs, *et al.*, 2007, Mondon, *et al.*, 2013). Among the three, PUGNAc was the most potent inhibitor of β -*N*-acetylglucosaminidase (Horsch, *et al.*, 1991). However, all three were found to inhibit human glucosaminidases rendering them less useful (Stubbs, *et al.*, 2007).

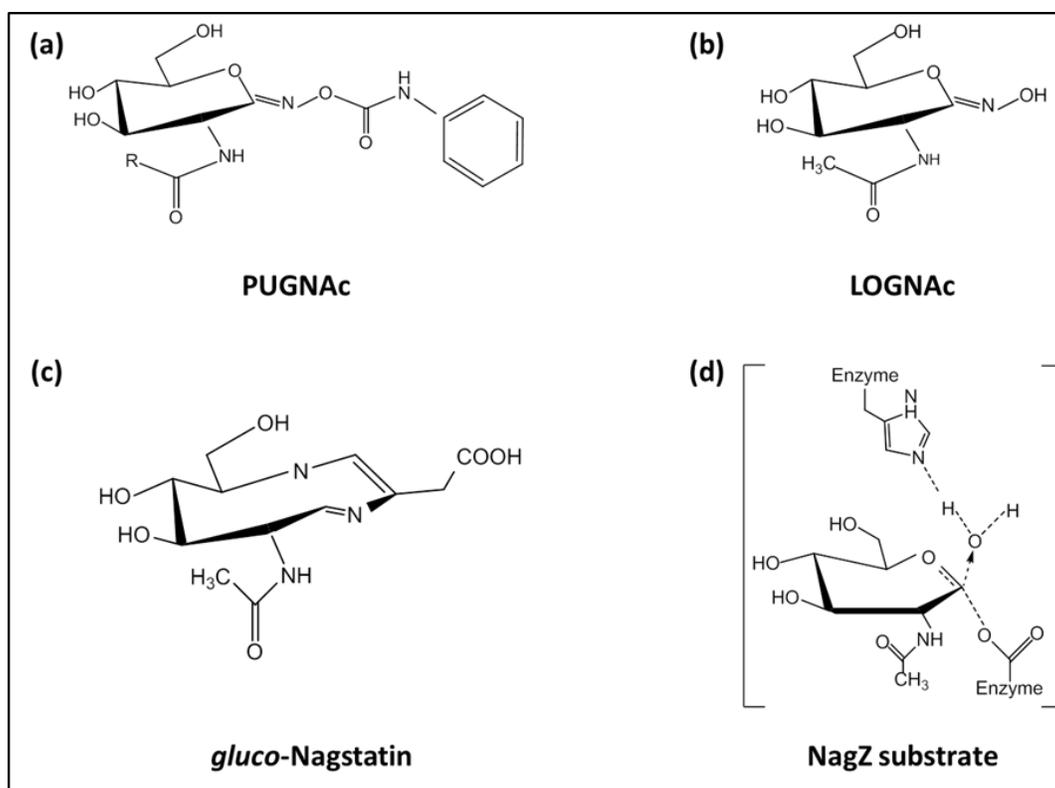

Figure 1.5. Small molecule inhibitors of N-acetyl- β -glucosaminidase NagZ. (a) O-(2-Acetamido-2-deoxy-D-gucopyranosylidene) amino N-phenylcarbamate (PUGNAc) (b) 1, N-acetylglucosaminono-1,5-lactone oxime (LOGNAc) (c) *gluco* analogue of 8-acetamido-5,6,7,8-tetrahydro-6,7-dihydroxy-5-(hydroxymethyl)imidazo[1,2-a] pyridine-2-acetic acid nagstatin (*gluco*-Nagstatin) (d) Transition state of NagZ substrate analogous to the small molecule inhibitors (Horsch, *et al.*, 1991, Stubbs, *et al.*, 2007).

Table 1.3. MIC of mutant strains of *P. aeruginosa*

Strains	MIC ($\mu\text{g/mL}$)									References
	AMP	PIP	CTX	CAZ	CEF	FOX	ATM	IMI	MER	
PAO1	1024	3.2	7	1.4	1.53	1024	10.4	1.2	0.41	(Ropy, <i>et al.</i> , 2015)
<i>dacB</i> *	1024	16	256	8	4	1024	8	1	0.5	
<i>dacC</i> *	1536	4	8	1	0.5	1024	2	0.5	0.5	
<i>pbpG</i> *	512	4	16	1	1	1024	4	1	0.5	
<i>ampC</i> *	32	2	8	1	1	64	4	0.12	0.25	
<i>dacB ampC</i> *	32	2	8	1	0.5	96	4	0.12	0.25	
<i>dacC ampC</i> *	16	2	4	0.75	0.5	64	2	0.06	0.25	
<i>pbpG ampC</i> *	32	4	8	1	0.5	96	3	0.12	0.25	
<i>dacB dacC</i> *	1024	128	512	16	4	1024	16	0.5	0.5	
<i>dacB</i>	16	2	4	1	0.5	64	2	0.06	0.12	

<i>dacC</i> <i>ampC</i> *										
<i>dacB</i> <i>pbpG</i> *	2048	16	256	8	4	1024	8	0.5	0.25	
<i>dacB</i> <i>pbpG</i> <i>ampC</i> *	32	2	6	0.75	0.5	64	2	0.12	0.5	
<i>dacC</i> <i>pbpG</i> *	1024	6	8	1	0.5	1024	2	0.5	0.25	
<i>dacC</i> <i>pbpG</i> <i>ampC</i> *	24	3	4	0.75	0.5	64	3	0.06	0.25	
<i>sltB1</i> ^	nd	12	16	1	nd	nd	nd	0.75	nd	(Cavallari, <i>et al.</i> , 2013)
<i>mltB</i> ^	nd	8	12	1.5	nd	nd	nd	1.5	nd	
<i>slt</i> ^	nd	1.5	6	0.19	nd	nd	nd	1	nd	
<i>mltF</i> ^	nd	2	6	0.38	nd	nd	nd	1	nd	
<i>sltB1</i> <i>ampC</i> ^	nd	1.5	2	0.5	nd	nd	nd	0.25	nd	
<i>mltB</i> <i>ampC</i> ^	nd	6	8	1	nd	nd	nd	0.38	nd	
<i>sltB1</i> <i>dacB</i> ^	nd	>25 6	>256	24	nd	nd	nd	1	nd	
<i>mltB</i> <i>dacB</i> ^	nd	192	>256	16	nd	nd	nd	1.5	nd	
<i>mltB</i> <i>sltB1</i> ^	nd	24	64	2	nd	nd	nd	1	nd	
<i>ampG</i> *	32	nd	8	1	nd	nd	nd	nd	nd	
<i>ampD</i> ^	nd	nd	nd	8	4	nd	6	2	1	(Juan, <i>et al.</i> , 2006)
<i>ampDh2</i> ^	nd	nd	nd	0.75	1	nd	1	1	0.38	
<i>ampDh3</i> ^	nd	nd	nd	1	1	nd	nd	1	0.38	
<i>ampR</i> ^	12	1.5	nd	1	1	nd	0.75	0.38	1.5	(Balasubramanian, <i>et al.</i> , 2012)
<i>poxA</i> ^	256	4	6	1.5	1.25	nd	2	1.25	0.44	(Zincke, <i>et al.</i> , 2015)
<i>poxB</i> ^	256	4	6	1.5	1	nd	2	1.5	0.38	
<i>ampC</i> <i>poxB</i> ^	24	4	6	1.5	1	nd	3	0.44	0.31 5	
<i>nagZ</i> ^	nd	nd	nd	1	1.5	nd	4	1	0.38	(Zamorano, <i>et al.</i> , 2011)
<i>creD</i> *	nd	nd	nd	8	4	nd	12	2	1	
<i>creD</i> <i>nagZ</i> *	nd	nd	nd	2	1.5	nd	4	1	0.38	
<i>dacB</i>	nd	nd	nd	1.5	2	nd	4	1	0.38	

<i>nagZ</i> *									
<i>creD</i>									
<i>dacB</i> *	nd	nd	nd	96	48	nd	24	2	0.5
<i>creD</i>									
<i>dacB</i>	nd	nd	nd	4	3	nd	4	1	0.5
<i>nagZ</i> *									

Table 1. 3. MIC levels of PAO1 and the corresponding deletion strains are indicated in the left. The MIC values of PAO1, shown in yellow, is an average of values as found in the cited references. Any values greater than PAO1 are shown in gradation of orange-red. Values lower than PAO1 shown in gradations of yellow- green.

AMP, Ampicillin; PIP, Piperacillin; CTX, Cefotaxime; CAZ, Ceftazidime; CEF, Cefepime; FOX, Cefoxitin; ATM, Aztreonam; IMI, Imipenem; MER, Meropenem.

*MIC determined by broth microdilution

^MIC determined by E-test

nd: not determined.

Details of PG recycling and their ties with β -lactam resistance have been studied in Enterobacteriaceae members. The role of many orthologous proteins including AmpR, AmpC, AmpD, and AmpG have been demonstrated in *P. aeruginosa* and appear to have similar roles to their Enterobacteriaceae counterparts (Langae, *et al.*, 2000, Kong, *et al.*, 2010, Johnson, *et al.*, 2013). In addition, new players such as *ampP*, *ampDh2*, and *ampDh3* have been identified in *P. aeruginosa* (Juan, *et al.*, 2006, Kong, *et al.*, 2010). Moreover, the localization of *P. aeruginosa* AmpR as an inner membrane protein with the helix-turn-helix domain in the cytoplasm and effector-binding domain in the periplasm leads to unique questions as to how the effector molecules are transported to their binding sites on AmpR (Caille, *et al.*, 2014).

1.6.2 β -Lactam resistance through other cell-wall-related genes

Other members involved in cell-wall recycling, namely, the LTs and the LMM PBPs also modulate β -lactam resistance. The periplasmic LTs are the major PG degradative enzymes that generate 1, 6-anhydro-MurNAc muropeptides (Lee, *et al.*, 2013). In *E. coli*, a double deletion of LT encoding genes *mltA-mltB*, *slt70-mltA* or *slt70-mltB* and a triple

deletion *mltA-mltB-slt70* exhibit a higher loss in β -lactamase activities than any one single deletion that correlates with the increasing decline in murein turnover (Kraft, *et al.*, 1999). In *P. aeruginosa*, the loss of Slt and MltF is associated with a decrease in β -lactam resistance (Cavallari, *et al.*, 2013). However, the loss of SltB1 and MltB led to an AmpC-independent increase in resistance to β -lactams, piperacillin, and cefotaxime (Cavallari, *et al.*, 2013, Lamers, *et al.*, 2015). The loss of the other *P. aeruginosa* LTs' MltA, MltD, MltF2, SltG, and SltH did not change the resistance profile (Cavallari, *et al.*, 2013)

The LMM PBPs comprise a group of enzymes that have endopeptidase and carboxypeptidase activity (Sauvage, *et al.*, 2008). Three of the five LMM PBPs (PBP4, PBP5, PBP6, PBP6b, PBP7/8) were investigated for their role in β -lactam resistance in *E. coli* (Sarkar, *et al.*, 2010, Sarkar, *et al.*, 2011). Loss of PBP5 reduces the MIC for penicillins and cephalosporins whereas PBP6 and PBP6b removal have no resistance phenotype (Sarkar, *et al.*, 2010). However, the lower MIC in PBP5 mutants can be partially restored by PBP6B. This suggests that PBP5 is important for β -lactam resistance followed by PBP6b (Sarkar, *et al.*, 2011). However, the role of PBP4, PBP6, and PBP7/8 in antibiotic resistance is not well understood.

P. aeruginosa has three LMM PBPs (PBP4, PBP5, and PBP7) whose role in β -lactam resistance has been investigated (Moya, *et al.*, 2009, Ropy, *et al.*, 2015). Clinical mutants of PBP4 (PA3047) are associated with increased β -lactam resistance (Moya, *et al.*, 2009). In fact, a mutation in PBP4 leads to a one step upregulation of *ampC* resulting in clinical β -lactam resistance (Moya, *et al.*, 2009). Similar to PBP6b in *E. coli*, the role of PBP5 is not evident, unless in the PBP4 background where the double mutant further increases β -lactam resistance (Table 3).

Interestingly, the PBPs in *E. coli* and *P. aeruginosa* play contradicting roles in β -lactam resistance. This may be reflective of the different mechanism of resistance, as *E. coli* has a non-inducible *ampC* (Honore, *et al.*, 1989). One speculation is that *E. coli* PBP5 could act as a “trap” for β -lactams thereby preventing access to their targets, the HMM PBPs whereas in *P. aeruginosa* loss of PBP4 results in increased production of the AmpR effector which escalates *ampC* β -lactamase expression and thereby the MIC (Moya, *et al.*, 2009, Sarkar, *et al.*, 2010, Moya, *et al.*, 2012, Lee, *et al.*, 2015).

1.6.3 Indirect regulation of β -lactam resistance through AmpR

Although *P. aeruginosa* AmpR acts as the nexus for AmpC β -lactamase induction and cell-wall recycling processes, it also modulates the activity of other proteins that regulate β -lactam resistance. One of these is the second chromosomally encoded β -lactamase, PoxB (PA5514) in *P. aeruginosa* (Kong, *et al.*, 2005). PoxB is a carbapenemase, which affects β -lactam resistance, in the absence of the major β -lactamase AmpC and outer membrane porin OprD (Zincke, *et al.*, 2015). Although no direct relation is seen between cell-wall recycling and *poxB*, AmpR is found to be a negative regulator of *poxB* through a yet unknown mechanism (Kong, *et al.*, 2005, Zincke, *et al.*, 2015).

Another mechanism of β -lactam resistance is through expulsion via efflux pumps namely MexAB-OprM (Poole, *et al.*, 1993). Expression of *mexAB* is repressed by a regulator MexR (Poole, *et al.*, 1996). AmpR is required for *mexR* expression, suggesting an opposite impact on β -lactam resistance (Balasubramanian, *et al.*, 2012). Moreover, deleting *ampC* and or *ampR* in PAO1 abolishes β -lactam resistance despite having a functional MexAB system or PoxB, suggesting that the AmpC is the major determinant of

β -lactam resistance (Balasubramanian, *et al.*, 2012, Kumari, *et al.*, 2014, Zincke, *et al.*, 2015).

Another mechanism of β -lactamase induction is mediated through the two-component system CreBC and its effector, an inner membrane protein CreD (Moya, *et al.*, 2009). In *E. coli*, CreB has been identified as a transcriptional factor that differentially regulates up to eight genes under diverse nutritional conditions (Avison, *et al.*, 2001). *E. coli* CreB was also found to regulate the expression of *Aeromonas hydrophila* β -lactamase (Avison, *et al.*, 2004). This two-component system in *P. aeruginosa* plays a pivotal role in β -lactam resistance and bacterial fitness (Zamorano, *et al.*, 2010, Zamorano, *et al.*, 2014). The inactivation of *dacB* (PBP4) leads to an increased expression of *creBC*, *creD*, and *ampC*. The increased expression of *ampC* is accompanied by elevated MIC of β -lactams, which reverts to wild-type levels upon deletion of *creBC* (Zamorano, *et al.*, 2014). The association of *creBC* and β -lactam resistance was seen only in *dacB* mutants and not with other mutations that confer high resistance namely, *ampD*, *ampDh2* and *ampDh3* (Moya, *et al.*, 2009). Moreover, these resistance phenotypes regulated through *creBC* were lost in the absence of NagZ and AmpG (Moya, *et al.*, 2009, Zamorano, *et al.*, 2010, Zamorano, *et al.*, 2014) (Table 3). Although the interplay of the cell-wall recycling components, *ampC* expression, and the *creBC-creD* system is found to regulate β -lactam resistance, the underlying details remain to be elucidated.

1.6.4 Cell-wall components contributing to non- β -lactam resistance

In addition to the various mechanisms by which the different components involved in PG biosynthesis and recycling confer β -lactam resistance, some cell-wall components

acting through AmpR also play a role in resistance to non- β -lactam antibiotics (Kumari, *et al.*, 2014). Some specific examples are discussed below.

Fluoroquinolone resistance

Quinolones, specifically fluoroquinolones, are potent, broad-spectrum synthetic antibiotics that inhibit DNA replication by targeting bacterial DNA gyrase (Gram-negatives) or topoisomerase II (Gram-positives) (Drlica, *et al.*, 2008). Due to their effectiveness against both Gram-positive and Gram-negative bacteria, extensive use of fluoroquinolones has led to a rapid rise in resistance (Chatterjee, *et al.*, 2016, Dan, *et al.*, 2016, Bader, *et al.*, 2017). Development of resistance to quinolones entails multiple mechanisms (Hernandez, *et al.*, 2011, Hooper & Jacoby, 2015). The primary mechanism of quinolone resistance in Gram-negative bacteria is through mutations in target genes *gyrA* and *gyrB* (Yamagishi, *et al.*, 1981, Yamagishi, *et al.*, 1986, Nakamura, *et al.*, 1989, Drlica & Zhao, 1997). Overexpression of MDR efflux pumps can also add significantly to the quinolone resistance especially in the presence of target mutations (Poole, 2000). Unexpectedly for synthetic antibiotics, horizontal gene transfer also plays role in quinolone resistance. A plasmid-mediated resistance gene *qnr* encoding a pentapeptide repeat protein protects the bacterial topoisomerases (gyrase and topoisomerase IV) from quinolone activity (Tran & Jacoby, 2002, Robicsek, *et al.*, 2006).

In *P. aeruginosa*, the MexEF-OprN system is involved in efflux of fluoroquinolones, chloramphenicol, and trimethoprim (Kohler, *et al.*, 1997). This efflux system is under the control of three different regulators; the positive regulator MexT, and the negative regulators MexS and MvaT (Kohler, *et al.*, 1999, Westfall, *et al.*, 2006, Uwate, *et al.*, 2013). *P. aeruginosa* AmpR negatively regulates the expression of the *mexEF-oprN*

operon and MexT (Balasubramanian, *et al.*, 2012). Consequently, PAO Δ *ampR* mutants are more resistant to fluoroquinolones compared to the wild type (Balasubramanian, *et al.*, 2012). Repression of the *mexEF* operon by AmpR is β -lactam independent (Balasubramanian, *et al.*, 2012), suggesting that AmpR functions diversified from the cell-wall synthesis pathway. It is important to note that AmpR positively and negatively regulates resistance to β -lactams and quinolones, respectively, highlighting the intricate and complex balance of regulation of antibiotic resistance (Balasubramanian, *et al.*, 2012, Balasubramanian, *et al.*, 2015).

Aminoglycosides resistance

Traditionally, the aminoglycoside class of antibiotics is used to treat Gram-negative infections. They bind to the 16S ribosomal subunit causing it to mistranslate leading to the synthesis of aberrant proteins (Davies, *et al.*, 1964, Kotra, *et al.*, 2000). Aminoglycosides, such as tobramycin, along with β -lactams form the first line of *P. aeruginosa* treatment for cystic fibrosis patients (Waters & Smyth, 2015). One of the primary determinants of aminoglycoside resistance in *P. aeruginosa* and other Gram-negative pathogens are the presence of active efflux pumps (Moore, *et al.*, 1999, Morita, *et al.*, 2012). The upregulation of the MexXY efflux pump in *P. aeruginosa* is considered the most common mechanism of aminoglycoside resistance (Poole, 2011). Aminoglycoside resistance can also be conferred by drug modifying enzymes such as aminoglycoside acetyl-, nucleotidyl-, and phospho-transferases (Lovering, *et al.*, 1987, Jacoby, *et al.*, 1990, Shaw, *et al.*, 1993, Azucena & Mobashery, 2001, Ramirez & Tolmasky, 2010). Mutations in *aac*, *aphA1*, and *aadB* that encode the aminoglycoside

modifying genes have been identified in clinical *P. aeruginosa* isolates (Kitao, *et al.*, 2009, Coyne, *et al.*, 2010, Teixeira, *et al.*, 2016).

In the presence of β -lactams, *P. aeruginosa* AmpR negatively regulates the expression of *mexX*, *mexY*, and *aph*; the latter encodes aminoglycoside phosphotransferase (Kumari, *et al.*, 2014). However, this negative regulation is not translated into an observable phenotype. On the contrary, loss of *ampR* increases aminoglycoside (amikacin and tobramycin) susceptibility in *P. aeruginosa* suggesting a positive regulation (Kumari, *et al.*, 2014). Thus, even with an increased expression of efflux and drug-modifying proteins, the *ampR* mutants are more susceptible to aminoglycosides, suggesting the existence of post- translational modifications in this complex regulatory network.

1.7 Dissertation overview

Pseudomonas aeruginosa and its various aspects of pathogenicity including antibiotic resistance has been the focus of researchers for many years. Previously our lab has explored the transcriptional factor AmpR that is known to regulate AmpC expression. Its role in *P. aeruginosa* was found to be more diverse and far-reaching when compared to that in other Gram-negatives such as *E. coli* and *C. freundii* (Balasubramanian, *et al.*, 2015). However, similar to what is found in *C. freundii* and *E. cloacae*, it is that *P. aeruginosa* AmpR binds with an activating effector generated during cell-wall recycling under β -lactam stress, which results in induction of AmpC (Vadlamani, *et al.*, 2015, Dik, *et al.*, 2017). The identity of this effector had not been previously established in *P. aeruginosa*. Also, cell-wall recycling has predominantly been studied only in *E. coli*.

In this dissertation, we investigate cell-wall recycling in *P. aeruginosa*. The structures of cell-wall recycling products or muropeptides found in *P. aeruginosa* are described as well as a method to quantitate muropeptides (Chapter 2). Additionally, we were able to identify the AmpR effector that is generated under β -lactam induction and binds to AmpR (Chapter 2). Furthermore, the role of permeases PA4393 and PA4218 in cell-wall recycling and antibiotic resistance are also investigated (Chapter 3). We also investigate a putative periplasmic *N*-acetylglucosaminidase that may play a role in generating the periplasmic effectors of AmpR (Chapter 4). Finally, the localization of AmpR is investigated and given its extensive regulon in *P. aeruginosa*, it is developed as an antibacterial target (Chapter 5). A novel phenotypic screening assay that identifies inhibitors of AmpR is discussed (Chapter 5).

Chapter 2

Muropeptides in *Pseudomonas aeruginosa* and their role as elicitors of β -Lactam antibiotic resistance

This chapter has been published:

Mijoon Lee⁺, Supurna Dhar⁺, Stefania De Benedetti, Dusan Heseck, Bill Boggess, Blas Blzquez, Kalai Mathee, and Shahriar Mobashery

Angew. Chem. Int. Ed. 2016, 55, 1 – 6

⁺ Authors contributed equally

2.1. Overview

This chapter is reproduced verbatim from the manuscript published in *Angewandte Chemie International Edition*. The supplementary portion of the manuscript has been integrated in the main text. I performed the muropeptide isolation from whole-cell and fractions, the induction experiments with *P. aeruginosa* PAO1 strains, and the colony forming unit for muropeptide quantitation. The synthesis of muropeptide standards was performed by Dr. Mijoon Lee and Dr. Dusan Hesek. The LC/MS analysis was performed by Dr. Mijoon Lee and Dr. Bill Bogess. The induction with mutant strains of *P. aeruginosa* was performed by Dr. Blas Blazquez and Dr. Stefania DeBenetti.

2.2 Abstract

Muropeptides are a group of bacterial natural products generated from the cell wall in the course of its turnover. These compounds are cell-wall recycling intermediates and are also involved in signaling within the bacterium. However, the identity of these signaling molecules remains elusive. The identification and characterization of 20 muropeptides from *Pseudomonas aeruginosa* is described. The least abundant of these metabolites is present at 100 and the most abundant at 55,000 molecules per bacterium. Analysis of these muropeptides under conditions of induction of resistance to a β -lactam antibiotic identified two signaling muropeptides (N-acetylglucosamine-1,6-anhydro-N-acetylmuramyl pentapeptide and 1,6-anhydro-N-acetylmuramyl pentapeptide). Authentic synthetic samples of these metabolites were shown to activate expression of β -lactamase in the absence of any β lactam antibiotic, thus indicating that they serve as chemical signals in this complex biochemical pathway.

Keywords: antibiotic resistance; bacteria; muropeptides; peptidoglycan; β -lactamase

2.3. Introduction

The cell wall (also known as the sacculus) is a complex macromolecular polymer that encases the bacterium. Its major constituent is comprised of repeating N-acetylglucosamine (NAG)-N-acetylmuramic acid (NAM), with a pentapeptide stem attached to the NAM unit (Vollmer, *et al.*, 2008, J. F. Fisher, 2015). Cell wall is critical for survival of the bacterium, hence, the cell wall and its biosynthetic machinery are targets of antibiotics (Bush, 2013). Cell wall is synthesized by polymerization of Lipid II, (van Heijenoort, 2007, Qiao, *et al.*, 2014) resulting in the NAG-NAM backbone, which is subsequently crosslinked to the neighboring strand through the peptide stem (Figure 2.1). In parallel, degradative processes that turn over segments of the assembled cell wall also take place (van Heijenoort, 2007, Park & Uehara, 2008). An important event in this turnover is mediated by a family of enzymes called lytic transglycosylases (LTs), whose reactions generate a series of natural products referred to collectively as muropeptides.

The reactions of all eight *Escherichia coli* LTs have been studied in vitro (Scheurwater, *et al.*, 2008, van Heijenoort, 2011, Lee, *et al.*, 2013, Yunck, *et al.*, 2016). These enzymes generate a transient oxocarbenium species (1) at the muramyl moiety of the peptidoglycan, which results in the cleavage of the β -1,4-glycosidic bond between a NAM and a NAG (Figure 2.1), giving rise to the 1,6-anhydromuramyl moiety (2 and 3). Some LTs perform this reaction at the ends of the peptidoglycan, the so called exolytic reaction, giving rise to the NAG-anhNAM disaccharides (2). Others perform the reaction in the middle of the peptidoglycan, the endolytic reaction, which gives rise to a longer backbone for the sugar (3). These released muropeptides are translocated to the cytoplasm by the permease AmpG (and possibly by AmpP in *Pseudomonas aeruginosa*)

(Kong, *et al.*, 2010). Once in the cytoplasm, the muropeptides enter the cell-wall recycling process, regenerating Lipid II (van Heijenoort, 2007, van Heijenoort, 2011, Johnson, *et al.*, 2013). Alternatively, other muropeptides are involved in signaling functions, leading to disparate responses such as antibiotic resistance, virulence, and inflammation (Boudreau, *et al.*, 2012, Fisher & Mobashery, 2014, Balasubramanian, *et*

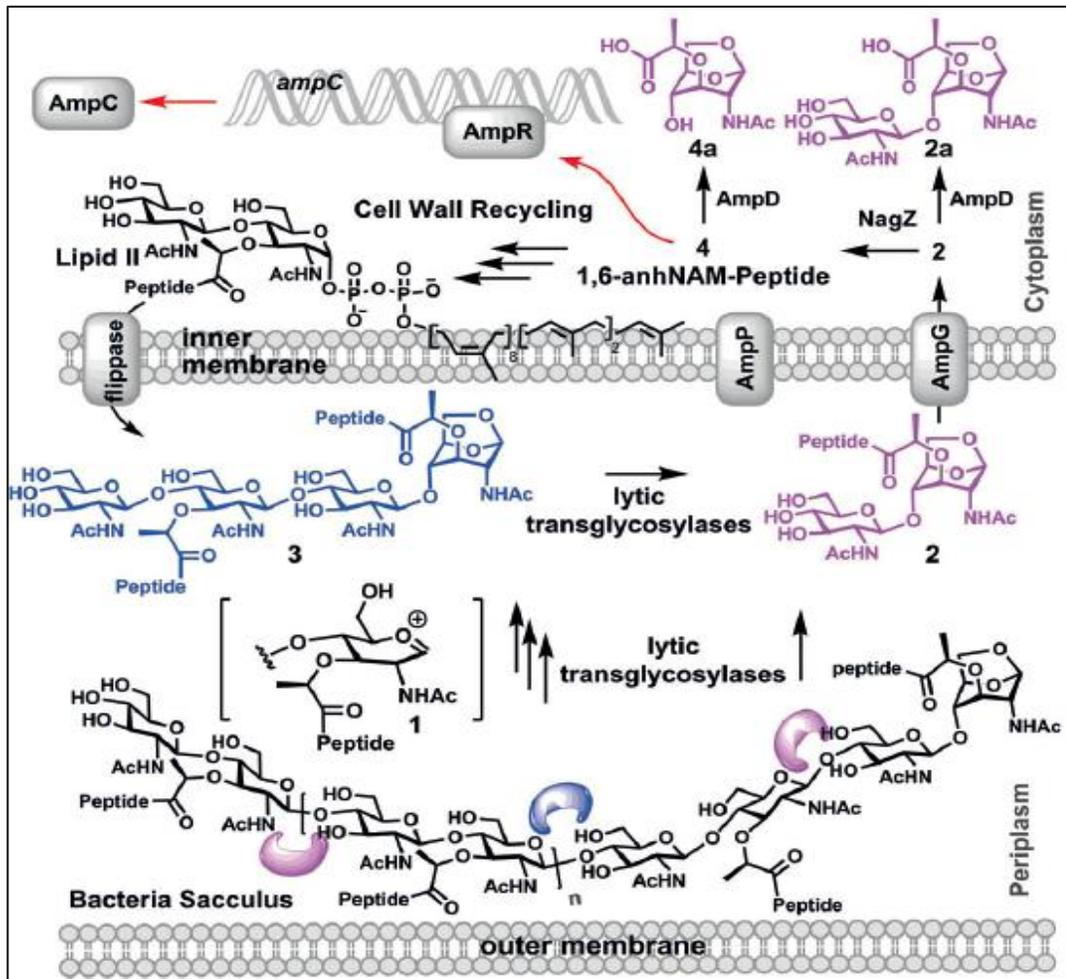

Figure 2.1. Muropeptides in recycling. The reactions of LTs produce muropeptides containing the 1, 6-anhydromuramyl moiety, which are translocated by the permease AmpG (and AmpP in *P. aeruginosa*). In normal growth of the bacteria, 4 would initiate recycling events to regenerate lipid II. However, as an offshoot of the recycling events, accumulation of 4 induces β -lactamase (AmpC) expression (indicated by red arrows).

al., 2015). The functions in resistance to β -lactam antibiotics involve binding to the gene regulator AmpR, which allows for transcription of the gene *ampC* for the Gram-negative AmpC β -lactamase (Figure 2. 1) (Jacobs, *et al.*, 1997, Kong, *et al.*, 2005). β -Lactamase hydrolyzes β -lactams antibiotics, which inhibit the action of penicillin-binding proteins by mimicking the structure of the terminal d-Ala-d-Ala in the stem peptides of the peptidoglycan.

The processes that muropeptides mediate are not fully understood due to impediments such as the minute quantities, rapid metabolic flux, and complexity of the structures. Once the structures are elucidated, they need to be prepared in the laboratory for validation of the assigned structure and for the conduct of biochemical studies. Here, we report the identification, characterization, and quantification of several muropeptides from periplasm of *P. aeruginosa*, an opportunistic human pathogen.

2.4. Materials and methods

2.4.1 Strains, media and growth conditions. *Pseudomonas aeruginosa* PAO1 and *P. aeruginosa* Z61 (ATCC 35151) were used in this study. *P. aeruginosa* was cultured in Luria Bertani broth (5 g tryptone, 10 g sodium chloride, and 5 g yeast extract per liter) supplemented with 1.5% agar when needed at 37 °C (Holloway, 1955). The antibiotic cefoxitin was added when required.

2.4.2 Induction and β -lactamase assay. Cefoxitin at half minimal-inhibitory concentration (512 μ g/mL) was used for induction of β -lactamase in *P. aeruginosa* PAO1 (Livermore, 2002). The antibiotic was added when cell culture was at OD₆₀₀ 0.2 and grown until OD₆₀₀ of 1.2. The culture was harvested, washed once and resuspended in 50 mM sodium phosphate buffer (pH 8). The suspension was sonicated. The sonicated

suspension was centrifuged, and the supernatant was used for analysis of β -lactamase activity. A 7.5- μ L portion of the supernatant of both induced and non-induced samples were added to 1 mL of the assay buffer with nitrocefin in a final concentration of 100 μ M. The absorbance at 500 nm was observed for 5 min (O'Callaghan, *et al.*, 1972). The $\Delta A_{500}/\text{min}$ was recorded for both induced and non-induced solution. The protein concentrations of the supernatants were estimated by BCA assay (Walker, 1994). The enzyme activity was expressed as the nanomole of nitrocefin hydrolyzed per min per mg of protein (Kong, *et al.*, 2005). Compounds 2e and 4e were used for induction of β -lactamase in *P. aeruginosa* Z61 (ATCC 35151) at 100 μ g/mL. Cefoxitin at quarter minimal-inhibitory concentration (0.0156 μ g/mL) was used as control. Compounds 2a and 4a were used (as negative control). The culture was grown to OD_{600} of 0.1 ($\sim 10^8$ CFU/mL) in LB medium and, subsequently, diluted 100-fold. LB medium (2.5 mL) containing the compound or the antibiotics were inoculated with 2.5 mL of the inoculum. Various cultures were allowed to grow within the range of OD_{600} of $\sim 1.0 - 1.8$. The rest of the protocol is the same as for the wild type. The result is summarized in Table 2

2.4.3. Bacterial cell counting. *P. aeruginosa* PAO1 was grown in LB broth until early stationary phase (OD_{600} of 1.2) was reached. Serial dilutions of the bacterial culture were plated on LB agar plates and incubated at 37 $^{\circ}$ C for 16-18 h. Colonies were counted and expressed as colony-forming units (CFU) per mL. Only plates with 30-300 colonies were considered. The average number was $4.9 \times 0.5 \times 10^8$ cell/mL of culture.

2.4.4 Syntheses of authentic muropeptides. The chemical structure of authentic compounds used in this study is given in Chart S1. Synthetic methods for **2e**, **4c**, **4d**, **4e**, **7**, and **8** were reported previously by Dr. Mobashery's laboratory and were followed for the samples used in the present study (Hesek, *et al.*, 2009, Lee, *et al.*, 2009, Lee, *et al.*,

2010). Compound **4a** was synthesized for this study by catalytic hydrogenation of the intermediate **9**. ¹H NMR (500 MHz, CD₃CN) δ 1.37 (d, J = 6.8 Hz, 3H), 1.93 (s, 3H), 3.37 (s, 1H), 3.55 - 3.72 (m, 3H), 3.90 (d, J = 8.4 Hz, 1H), 4.11 (d, J = 7.4 Hz, 1H), 4.24 (q, J = 6.8 Hz, 2H), 4.50 (d, J = 5.2 Hz, 1H), 5.31 (s, 1H), 6.79 (d, J = 8.6 Hz, 1H); ¹³C NMR (126 MHz, CD₃CN) δ 18.7, 23.0, 50.5, 66.1, 69.7, 74.8, 77.2, 79.8, 101.5, 118.3, 171.3, 175.0; HRMS (ESI-QTOF) m/z [M+H]⁺ Calcd 276.1078 for C₁₁H₁₇NO₇; found 276.1101. Compound **2a** was obtained from incubation of compound **2e** with an amidase AmpDh3 of *P. aeruginosa* (Martinez-Caballero, *et al.*, 2013, Zhang, *et al.*, 2013). The reaction product **2a** was confirmed by high-resolution mass spectrometry, which is consistent with the chemical formula of C₁₉H₃₀N₂O₁₂: HRMS (ESI-QTOF) m/z [M+H]⁺ Calcd 479.1872; found 479.1844. Its chemical nature was further confirmed by LC/MS/MS experiment (Figure S1A). Compound **2d** was obtained from incubation of compound **2e** with penicillin-binding protein 4 of *P. aeruginosa*. [9] The reaction product **2d** was confirmed by high-resolution mass spectrometry, which is consistent with the chemical formula of C₃₇H₅₉N₇O₂: HRMS (ESI-QTOF) m/z [M+H]⁺ Calcd 922.3888; found 922.3840. Its chemical nature was further confirmed by LC/MS/MS experiment (Figure S1B).

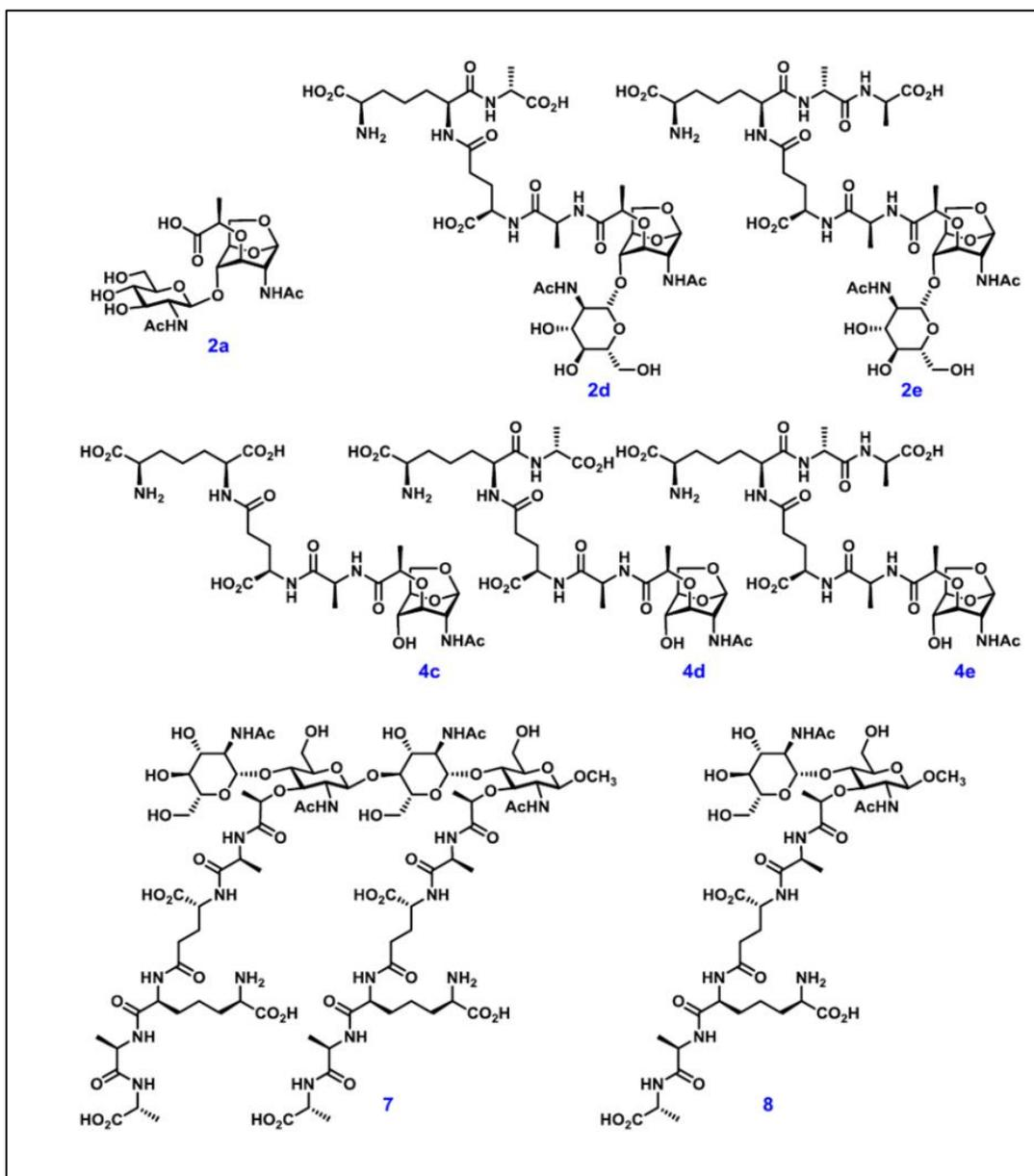

Figure 2.2. The chemical structure of authentic mucopeptides used in this study.

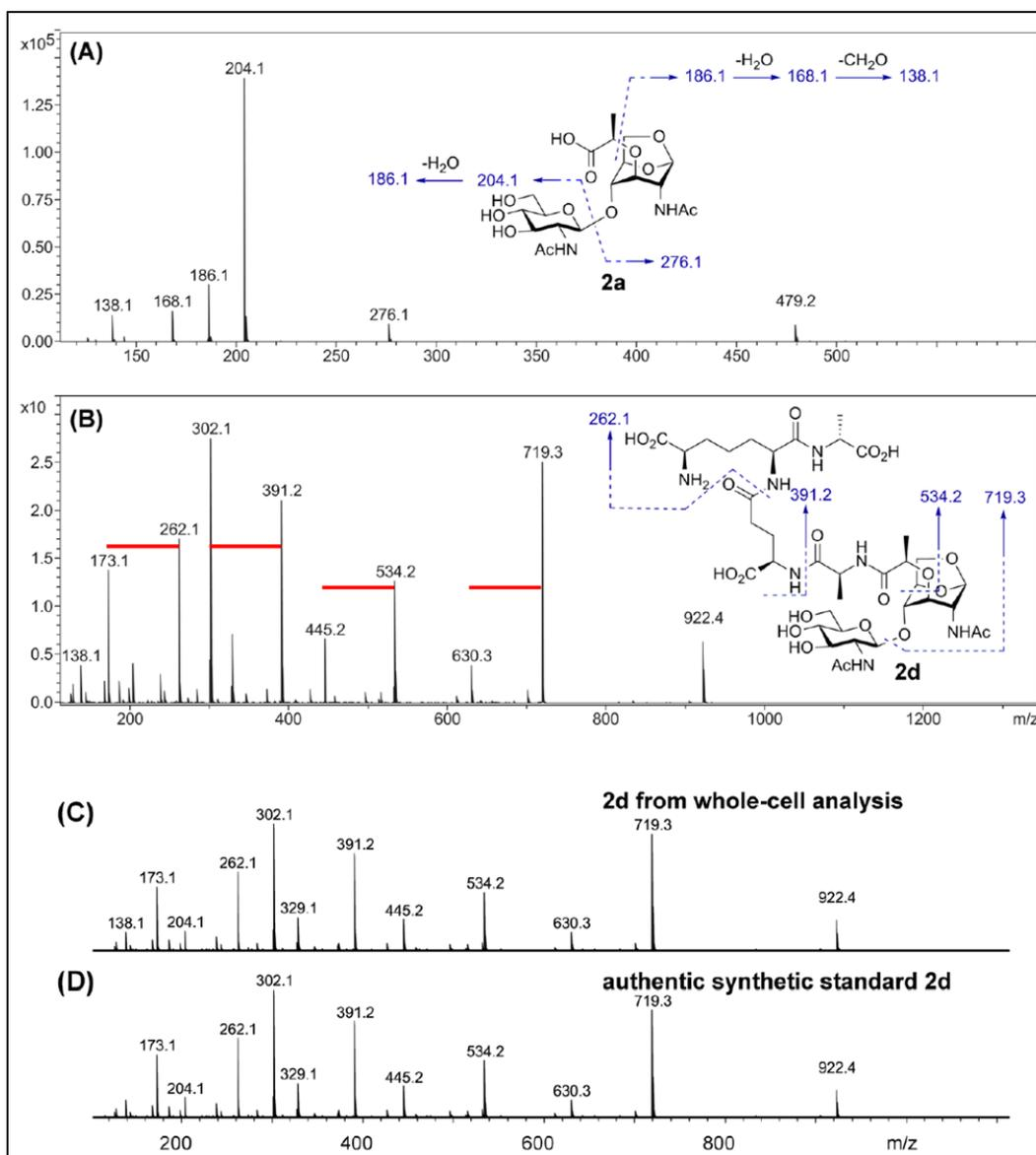

Figure 2.3. Collision-induced dissociation spectra. Of **2a** (**A**), **2d** (**B**), and side-by-side comparison to authentic synthetic standard **2d** (**C** and **D**). Losses of Ala are indicated in red bar in (**B**).

2.4.5 Sample preparation: release of muramyl peptides from whole-cell. *P. aeruginosa* PAO1 with and without induction (cefoxitin 512 µg/mL) was grown until late log to early stationary phase (OD₆₀₀ 1.2). The culture was harvested by centrifugation at 4,500 g for 20 min and the supernatant discarded. The cell pellet was resuspended gently in cold sucrose solution (20% sucrose, 1.2 mM EDTA, 30 mM Tris, pH 8) and left at 4 °C for 10 min. This was centrifuged, and the pellet resuspended in ice-cold water. The suspension was incubated at 4 °C for 10 min, and then centrifuged at 11,000 g for 20 min and the supernatant was discarded. The pellet was then boiled for 3 min and sonicated to ensure complete release of muropeptides. The sample was filtered using the 30-kDa molecular weight cut off mini-column. The flow-through was boiled for 6 min to remove any residual enzymatic activity, concentrated by speed vacuum at 50 °C and used for LC/MS analyses.

2.4.6 Detection and quantification of muropeptides by LC/MS. LC/MS conditions for muropeptide detection corresponded to those in the method developed by Dr. Mobashery's laboratory (Lee, *et al.*, 2013). Peak areas from extracted ion chromatograms of corresponding muropeptides were integrated and normalized to internal standard (compound **8**). Quantification of muropeptide was done from the standard curve of synthetic compound **2e**. Standard curves for **2e**, **4c**, **4d**, **4e**, and **7** were determined and they were very similar within 7% variation of each other (Figure S2). The collection of our synthetic standards covers distinctive chemical structures of >95% of detected muropeptide. So, we chose **2e** as a synthetic standard for quantification, as it has the closest structure to **2d**, the most abundant detected species.

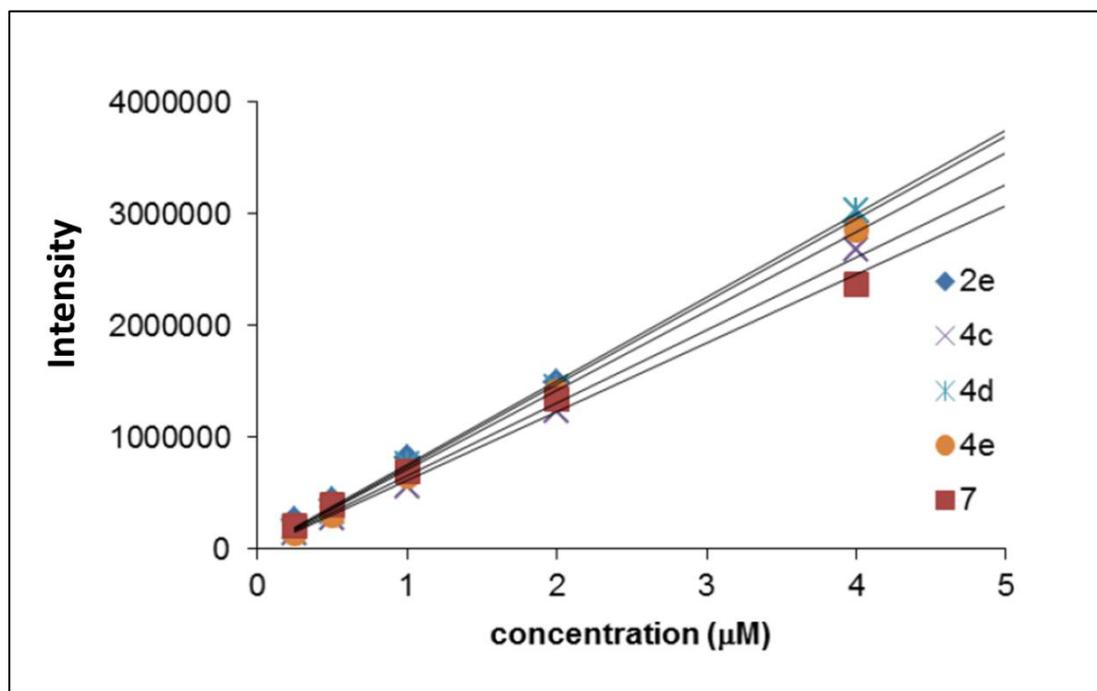

Figure 2.4. Standard curves of synthetic standards, **2e**, **4c**, **4d**, **4e**, and **7**.

2.4.7 Calculation of number ofuropeptides per cell. The concentration of **2d** was calculated from the standard curve of authentic standard **2e**, which is 4.5×10^{-11} mol/mL of culture. This was converted to mol/cell (x) using the value obtained from bacterial cell counting, described above. The value x then was converted to number of molecules (y) using Avogadro's number, 6.022×10^{23} /mol. The rest ofuropeptides were calculated the same way as **2d** and numbers are given in Table 1.

$$x = 4.5 \times 10^{-11} \text{ mol/mL}$$

$$4.9 \times 10^8 \text{ cell/mL} = 9.2 \times 10^{-20} \text{ mol/cell}$$

$$1 : 6.022 \times 10^{23} = 9.2 \times 10^{-20} \text{ mol} : y$$

$$y = 5.5 \times 10^4 \text{ molecules/cell}$$

2.5. Results and Discussion

Sample preparation is important, as dilution of the minute quantities and contamination could confound analysis. Initially, osmotic shock was used for liberation of the periplasmic content that contains the muropeptides. This would have separated the periplasmic and cytoplasmic metabolites before attempt at isolation of muropeptides. Unfortunately, 10-30% cytoplasmic contamination was noted in these samples. The results were also not reproducible, and muropeptides could merely be identified near the detection limit of 0.4 pmol by our instrumentation.

The muropeptides that enter the cytoplasm via the permease AmpG (or AmpP) are expected to undergo rapid metabolic flux (Figure 2.1). This assertion was documented by preparing spheroplasts of *P. aeruginosa* PAO1. The cytoplasmic content from the lysed spheroplasts were analyzed by LC/MS for muropeptides. None could be detected, suggesting that the cytoplasmic muropeptides were rapidly metabolized to Lipid II, with concentrations below our detection limit. Hence, the whole bacterium was grown and lysed, an approach that proved to be reliable and reproducible. The muropeptides that were generated under these conditions could only have come from the intact periplasm in the whole bacterium. After sample preparation, the LC/MS analyses were performed for detection and identification of muropeptides. The muropeptide content of the whole cells of *P. aeruginosa* PAO1 was compared in the absence and presence of half of the minimal-inhibitory concentration (MIC) of antibiotic cefoxitin, a β -lactam that interferes with cell-wall synthesis (Livermore, 1995). Cefoxitin at sub-MIC levels activates the expression of β -lactamase efficiently, thereby leading to antibiotic resistance in *P. aeruginosa*. This is believed to be mediated by a messenger

function of a mucopeptide. Hence, one or more of the mucopeptides listed in Figure 2A is expected to serve as the signaling molecule for antibiotic resistance.

As shown in Figure 2A, compounds are numbered according to the nature of the sugar, 2 for NAG-1,6-anhNAM and 4 for 1,6-anhNAM. For the peptide component, a has no peptide, b, c, d, and e carry di-, tri-, tetra- and pentapeptide, respectively (full pentapeptide is L-Ala-γ-D-Glu-m-DAP-d-Ala-d-Ala; bottom right of Figure 2A). Compounds **3** are (NAG-NAM-peptide) n-NAG-1,6-anhNAM-peptide and compounds **5** are for cross-linked species. For example, compound **5dd** indicates cross-linked peptide between two tetrapeptides. Compounds with reducing-end sugars, which lack the 1, 6-anhNAM, were also detected as minor components and are designated with the letter R.

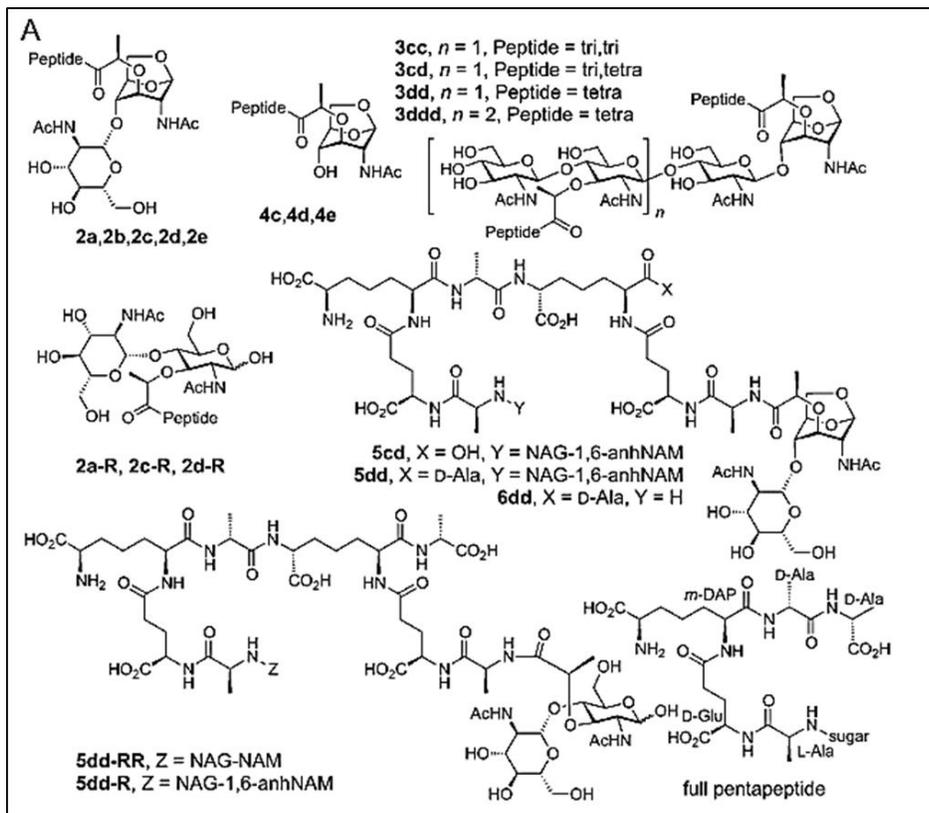

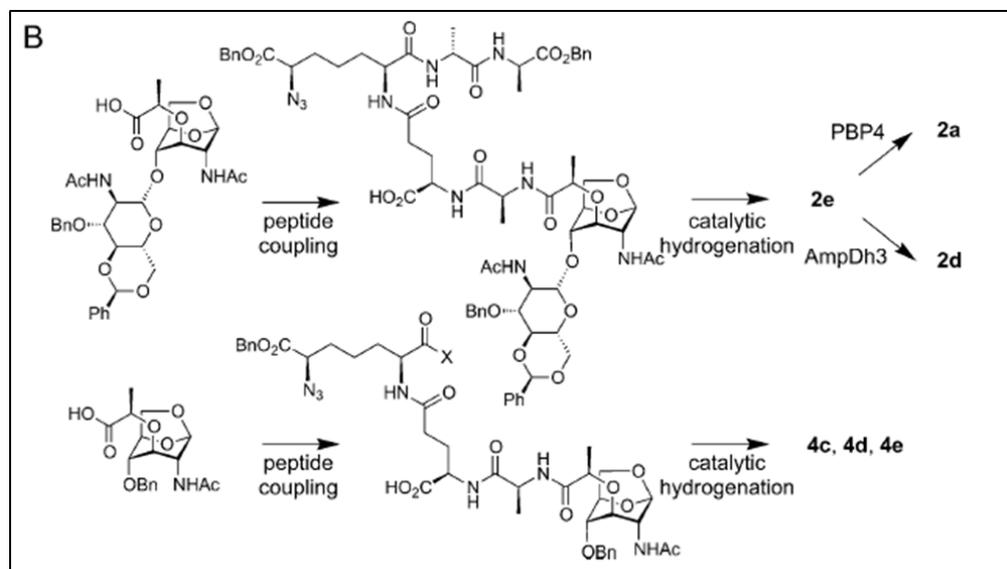

Figure 2. 5. A) Chemical structures of detected muropeptides. **B)** The chemoenzymatic syntheses of six muropeptides.

Four muropeptides, **2e**, (Hesek, *et al.*, 2009) 4c, 4d, and 4e (Lee, *et al.*, 2009, Zhang, *et al.*, 2013) were synthesized. A few of these authentic samples were also converted to new species by known enzymatic reactions (Figures. 2B and S1). For example, **2e** was converted to **2d** by the use of penicillin-binding protein 4 (PBP4), (Lee, *et al.*, 2015) and **2e** to **2a** using AmpDh3, (Zhang, *et al.*, 2013) both purified recombinant enzymes from *P. aeruginosa*. Figures. 3C-3F show EICs of the detected metabolites **2a**, **2d**, **2e**, **4c**, and **4d**, and their comparison to the authentic standards (Figure 3G). Analysis was further done with comparison of MS and MS/MS with authentic samples, as exemplified in Figure S1. For structure assignment of metabolites whose authentic standards were not available, the method that was developed previously by Dr. Mobashery's laboratory to analyze turnover products of sacculus by LTs and PBP4 was used (Lee, *et al.*, 2013, Lee, *et al.*, 2015).

Quantification was done by integrating peak areas from EICs of the corresponding *m/z* values of the individual muropeptide. This was converted to

concentration using standard curves generated with the authentic **2e**. The concentration was converted to numbers of molecules (of each compound) per bacterium (Table 1; SI). Standard curves for **2e**, **4c**, **4d**, **4e** and **7** (β -methoxy-NAG-NAM (pentapeptide)-NAG-NAM (pentapeptide))(Lee, *et al.*, 2010) were very similar within 7% variation of each other (Chart S1 and Figure S2). The collection of our synthetic standards covers distinctive chemical structures of >95% of the detected muropeptides. So, **2e** was chosen as a representative synthetic standard for quantification. The most abundant muropeptide in wild-type PAO1 strain is NAG-1, 6-anhNAM-tetrapeptide (**2d**). The di-, tri-, and pentapeptide variants (**2b**, **2c**, and **2e**) are also found, along with **2a** (with no peptide). These are reaction products of LTs, mostly from the exolytic activity. The discovery of compounds with the core 1,6-anhNAM-peptides (**4c** and **4d**) suggests the existence of the N-acetylglucosaminidase activity in *P. aeruginosa*. The presence of such an enzyme (FlgJ) in the periplasm was recently documented in *Salmonella enterica* (Herlihey, *et al.*, 2014). This activity in *P. aeruginosa* might be mediated by PA1085, which has an identity of 31% and a similarity of 46% at the amino-acid level to FlgJ from *S. enterica* (Figure S3) (Herlihey, *et al.*, 2014). To our knowledge this is the first documentation of a periplasmic N-acetylglucosaminidase reaction product in *P. aeruginosa* (Herlihey, *et al.*, 2014). Oligomeric sugars (up to hexamers) with tetrapeptide (**3dd** and **3ddd**) or a mix of tetra and tripeptide (**3cd** and **3cc**) were also found. These are products of the endolytic reactions of LTs (Johnson, *et al.*, 2013).

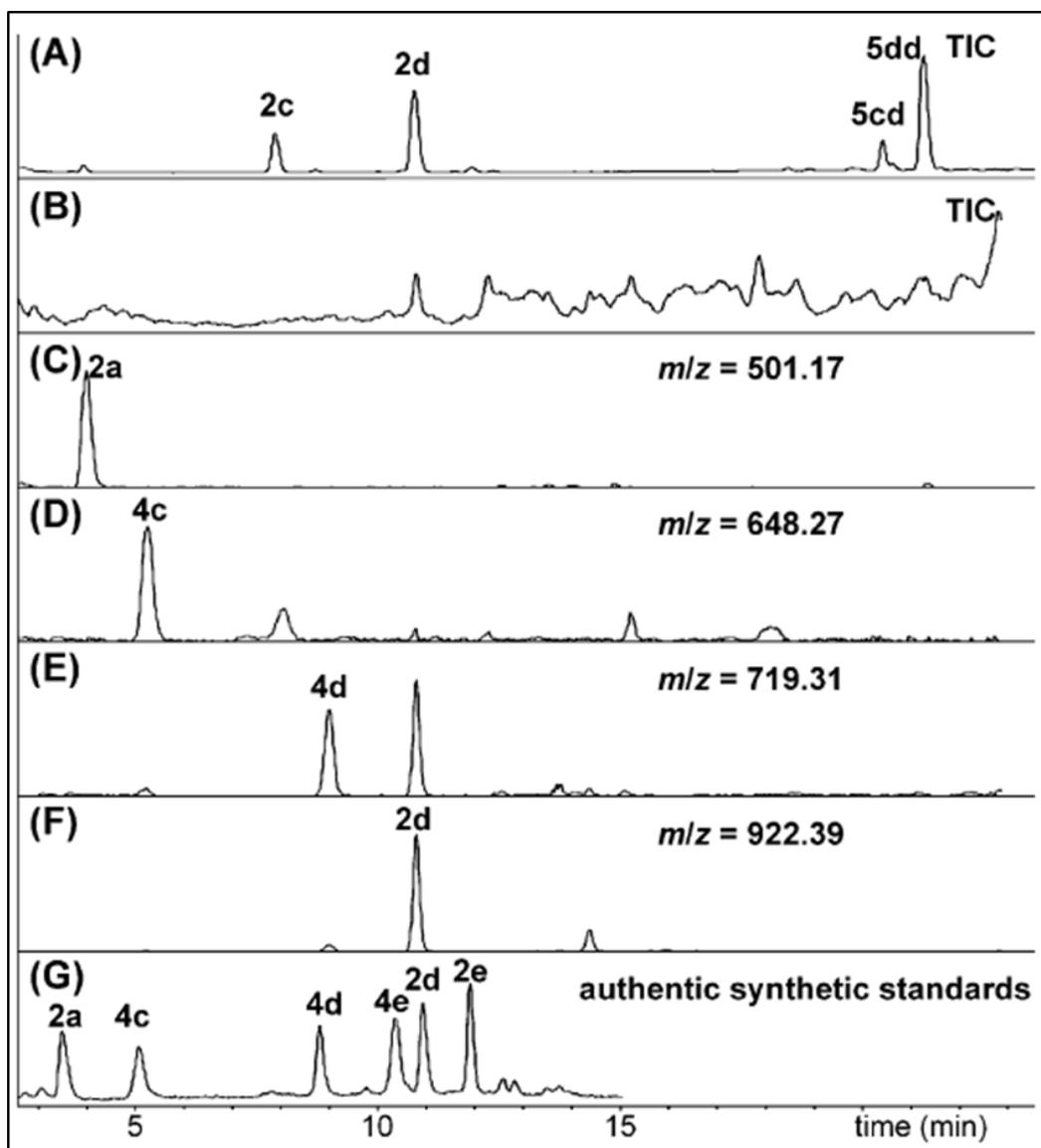

Figure 2.6. Analysis of *P. aeruginosa* muropeptides. The LC–MS TICs of sacculus digested by MltA (A) and whole-cell analysis (B). EICs of 2a (C), 4c (D), 4d (E), and 2d (F) from whole-cell samples, and the TIC of authentic synthetic standards mixed together (G).

Muropeptide	Wild-type	Induced ^[b]	<i>p</i> -value ^[c]
NAG-1,6-anhNAM			
2a	1.5 ± 0.07	0.3 ± 0.01	0.01*
2b	0.2 ± 0.01	0.08 ± 0.01	0.004*
2c	0.8 ± 0.05	0.3 ± 0.02	0.02*
2d	5.5 ± 0.3	1.0 ± 0.3	0.002*
2e	0.01 ± 0.005	0.1 ± 0.02	0.04*
1,6-anhNAM			
4c	0.3 ± 0.06	0.1 ± 0.003	0.0003*
4d	0.4 ± 0.01	0.07 ± 0.003	0.01*
4e	N.D. ^[d]	0.08 ± 0.01	0.04*
(NAG-NAM)_n-NAG-1,6-anhNAM			
3cc	0.1 ± 0.01	0.02 ± 0.006	0.003*
3cd	0.2 ± 0.02	0.03 ± 0.007	0.03*
3dd	0.9 ± 0.06	0.09 ± 0.03	0.002*
3ddd	0.1 ± 0.02	0.01 ± 0.003	0.049*
NAG-1,6-anhNAM-crosslinked-1,6-anhNAM-NAG			
5cd	0.03 ± 0.004	0.02 ± 0.001	0.2
5dd	0.3 ± 0.01	0.07 ± 0.007	0.001*
6dd	0.04 ± 0.001	0.02 ± 0.004	0.07
Reduced end			
2a-R	0.07 ± 0.01	N.D. ^[d]	0.02*
2c-R	0.07 ± 0.03	0.02 ± 0.002	0.11
2d-R	0.5 ± 0.1	0.1 ± 0.03	0.06
5dd-RR	0.1 ± 0.002	0.01 ± 0.002	0.0002*
5dd-R	0.02 ± 0.002	0.009 ± 0.002	0.047*
Total ^[e]	11.1 ± 0.8	2.4 ± 0.5	

Table 2.1 Detected muropeptides from whole-cell analysis (in molecules per bacterium X 10⁴ [a] Average of two runs. [b] PAO1 was exposed to cefoxitin at 512 mg/mL¹. [c] *p*-values from Students t-test. * Significant difference (*p*<0.05) between the wild-type and induced samples. [d] Not detected. [e] Total detected muropeptides.

the antibiotic-resistance determinant (Kong, *et al.*, 2010, J. F. Fisher, 2015). The induction of resistance was confirmed by the β -lactamase assay using nitrocefin.

The same number of bacteria and the same conditions were used in both cases; hence, the values of the two columns of Table 1 can be compared to each other. The analysis showed that the total muropeptide (molecules/bacterium) was significantly reduced (p -value < 0.05 by Student's t-test) in the induced vs the uninduced case: 24,000 vs. 111,000 (Table 1). The most abundant muropeptide in the uninduced sample was **2d** (NAG-1, 6-anhNAM-tetrapeptide). Muropeptide **2e** (NAG-1, 6-anhNAM-pentapeptide) was enriched at 46-fold upon antibiotic induction (1000 in 24,000 molecules vs. 100 in 111,000 molecules). That is to say that the β -lactam antibiotic inhibits the targeted PBP, whose lack of activity leaves its peptidoglycan substrate in the sacculus intact. This observation in living bacteria agrees with the finding of the in vitro sacculus analysis of the induced *P. aeruginosa* (Moya, *et al.*, 2012, Lee, *et al.*, 2015). Compound **4e** was detected only in the induced sample. This observation suggests that as the concentration of **2e** increased upon induction, the compound was likely turned over by the aforementioned N-acetylglucosaminidase to produce **4e**. Other than **2e** and **4e**, the rest of muropeptides detected in the induced sample were similar to those in the uninduced. It is not immediately obvious as to why the total quantity of muropeptides is lower in the induced sample (one fifth of the uninduced). This likely reflects the altered cell-wall modifications of the bacterium in the presence of the sub-lethal concentration of the antibiotic.

The obvious question now becomes whether exogenously added authentic muropeptides **2e** or **4e** could cause induction of antibiotic resistance in the absence of antibiotic. We investigated this first with the wild-type *P. aeruginosa* PAO1 strain.

Addition of muropeptide **2e** or **4e** at upwards of 500 µg/mL failed to induce β-lactamase expression (Table 2.2). Going with the premise that the Gram-negative outer membrane is a formidable barrier to penetration of most small molecules into the periplasm, we procured a mutant strain defective in its outer membrane. The strain *P. aeruginosa* Z61 has the full complement of the genes necessary for induction of β-lactamases, but it expresses a mutant version of the β-lactamase with diminished activity (Angus, *et al.*, 1982). Nonetheless, using the nitrocefin assay we observed a 4.7-fold increase of induction of β-lactamase at quarter-MIC level of cefoxitin.

Inducer	Wild-type (PAO1)			Mutant (Z61) ^[b]		
	Conc. [µg mL ⁻¹]	β-lactamase induction ^[c]		Conc. [µg mL ⁻¹]	β-lactamase induction ^[c]	
Cefoxitin ^[d]	512	136 ^[e]	1555/11.4	0.0156	4.7 ^[e]	4.6/0.98
2e	500	1.0	19.1/19.1	100	1.4 ^[e]	27.5/20.0
4e	500	1.0	19.1/19.1	100	1.7 ^[e]	5.5/3.3
2a ^[d]		— ^[f]		10 ^[g]	1.0	4.1/4.0
4a ^[d]		— ^[f]		100	1.0	3.6/3.5

Table 2.2. Induction of β-lactamase activity by three inducers [a] Average of two runs. **[b]** The strain is defective in its outer membrane. **[c]** The number (the left column) is calculated from β-lactamase activity in the presence of an inducer divided by that without an inducer (the right column) under the same conditions. The enzyme activity was expressed as nmol of nitrocefin hydrolyzed per min per mg of protein for wild-type and pmol/min/mg for mutant. **[d]** Cefoxitin and compounds **2a** and **4a** were used as positive and negative controls for induction, respectively. **[e]** β-Lactamase activities were significantly different ($p < 0.05$) between induced and uninduced samples. **[f]** Not measured. **[g]** Owing to limited supply of compound, we could only assess the effect at the lower concentration.

The same experiment performed with the bacteria exposed to 100 µg/mL muropeptides **2e** or **4e** resulted in 1.4 or 1.7 induction, respectively (Table S1). This is a large excess of these compounds, but we used them so, as we had expected that the

exogenously added compounds would undergo turnover by periplasmic enzymes. Hence, the two metabolites—both produced in response to the exposure of bacteria to the antibiotic inducer cefoxitin—collectively account for most of the induction observed by cefoxitin. We note that compound **2a** and **4a** (metabolites without a peptide stem; products of the reaction of AmpD) as negative controls. As expected, under the same conditions, induction was not observed. Activity of AmpD (Figure 1) is at the crossroads of induction of resistance vs. cell-wall recycling (reversal of induction).

This study reports the nature and quantities of 20 muropeptides from *P. aeruginosa*. The levels of muropeptide **2e** became elevated by 46-fold on exposure of bacteria to sub-MIC levels of a good inducer, cefoxitin. We also observed muropeptide **4e** only in the induced cells. This study discloses that authentic synthetic samples of muropeptides **2e** and **4e** could serve as inducers of β -lactam-antibiotic resistance in the absence of antibiotic. These experiments clearly document that at least muropeptides **2e** and **4e** are chemical elicitors of induction of antibiotic resistance.

2.6. Acknowledgements

This work was supported by grant GM61629 from the NIH (to SM) and in-part by NSF IIP-1237818 [PFI-AIR: CRESTI/UCRC-Industry Ecosystem to Pipeline Research] (KM), Florida International University (FIU) Bridge Funding (KM), FIU Herbert Wertheim College of Medicine Graduate Assistantship (SD).

Chapter 3

Role of *P. aeruginosa* permeases PA4393 and PA4218 in antibiotic resistance and cell-wall recycling

3.1 Abstract

Pseudomonas aeruginosa is well-known for its intrinsic as well as acquired resistance to multitude of antibiotics including fluoroquinolones, aminoglycosides, macrolides and the β -lactams. A frequent mechanism of resistance to β -lactams is through expression of the hydrolytic enzymes, β -lactamases. Expression of the major β -lactamase AmpC is regulated by a LysR-type transcriptional regulator AmpR, contingent upon its binding with specific muropeptides. In *P. aeruginosa*, there are two inner membrane permeases that may serve as muropeptide transporters; PA4393 (AmpG) and PA4218 (AmpP). It was postulated that AmpG imports the muramyl peptides into the cytoplasm whereas AmpP exports into the periplasm. In this research, we investigate the role of AmpG and AmpP in antibiotic resistance and as muropeptide transporters. To address their role three in-frame deletion mutants were constructed $\Delta ampG$, $\Delta ampP$, and $\Delta ampG\Delta ampP$ in PAO1. The resistance and muropeptide profile of these three mutants were compared against PAO1, respectively. A single deletion of *ampG* resulted in decreased resistance profile as compared with the wild-type PAO1, for many of the β -lactams as well as for fosfomycin. *ampP* deletion however, did not result in altering susceptibility. The profile of muropeptides was investigated by LC/MS/MS. The whole-cell extracts across all the strains (wild-type and permease mutants) were examined for muropeptides and it was found that the relative levels of muropeptides were similar in PAO1 and PAO $\Delta ampG$ deletion. The levels of disaccharide peptides in $\Delta ampP$ and $\Delta ampG\Delta ampP$ were lower in the periplasm and the cytoplasm respectively, compared to PAO1. This is indicative of AmpP playing a role in muropeptide transport and supports our hypothesis. Periplasmic analysis of the muropeptides revealed that levels of monosaccharides were lower for all the strains in the periplasmic space as compared

with whole-cells. This method of muropeptide detection is highly sensitive and allows us to compare the relative levels of muropeptides across bacterial strains.

3.2 Introduction

Muropeptides or cell-wall fragments are created whenever the bacterial cell divides. Gram-negative and Gram-positive pathogens have a dedicated recycling pathway that salvages these muropeptides and utilizes them during rebuilding of the cell-wall (Boothby, *et al.*, 1973, Goodell, 1985). The muropeptides besides being recycled to conserve energy resources also play critical roles in bacterial survival and virulence. In Gram-positive pathogen *Bacillus subtilis*, Gram-negative bacteria *Myxococcus xanthus* and *Micrococcus luteus*, muropeptides trigger reactivation of dormant spores in response to environmental cues (Shimkets & Kaiser, 1982, Mukamolova, *et al.*, 2006, Shah, *et al.*, 2008). In *P. aeruginosa*, production of a toxin, pyocyanin is modulated by peptidoglycan fragments containing *N*-acetylglucosamine (Korgaonkar & Whiteley, 2011). The muramyl peptides also have well defined role as stimulants of the host immune system (Takeuchi & Akira, 2010). This immune response in a healthy individual is triggered partly by certain elements of the bacterial cell itself known as pathogen associated molecular patterns (PAMP) (Janeway, 1989). These include mainly the lipopolysaccharide, peptidoglycan, flagellin proteins and lipotechoic acid in Gram-positive bacteria. These structures are recognized by the innate immune system, namely the Toll-like receptors (TLR) and the nucleotide-binding oligomerization domain (NOD) (Takeuchi & Akira, 2010, Fujimoto & Fukase, 2011). Peptidoglycans in specific are recognized by the NOD family- Nod 1, Nod 2, cryopyrin and the peptidoglycan response proteins (PGRP) (McDonald, *et al.*, 2005, Fujimoto & Fukase, 2011). Specifically, γ -D

glutamyl-*meso*-diaminopimelic acid muramyl dipeptides act as recognition moieties and activate the pro-inflammatory cytokines (Chamaillard, *et al.*, 2003, Girardin, *et al.*, 2003, Boudreau, *et al.*, 2012). Due to the key role of muropeptides both within the bacteria as signaling components as well as in the eukaryotic host as an immune stimulus, identifying the muropeptides and the recycling process becomes significant in understanding bacterial activity and its interaction with host. The recycling pathway has evolved in many Gram-negative pathogens however it has been best studied in *E. coli* (Park & Uehara, 2008, Johnson, *et al.*, 2013, Dhar, *et al.*, 2018).

During the cell wall recycling process in *E. coli*, PG fragments are generated in periplasm through the activity of lytic transglycosylases, penicillin binding proteins (PBP) and amidases (Holtje, *et al.*, 1975, Park & Uehara, 2008). PG fragments enter the cytoplasm through permease AmpG (Jacobs, *et al.*, 1994). In the cytoplasm, they are initially processed by two enzymes, NagZ that removes the *N*-acetylglucosamine residue followed by AmpD which cleaves the peptide chain from the muropeptide (Yem & Wu, 1976, Jacobs, *et al.*, 1994, Jacobs, *et al.*, 1995, Heseck, *et al.*, 2009). The recycling process in *P. aeruginosa* has not been completely elucidated and there have been no studies that determine the muropeptide profile of *P. aeruginosa*. Bioinformatic analyses led to the identification of *E. coli* homologs of the recycling pathway (Kong, *et al.*, 2010, Dhar, *et al.*, 2018). However, there are differences in the recycling pathway in *P. aeruginosa* when compared with other members of Enterobacteriaceae. *P. aeruginosa* has periplasmic paralogs of AmpD known as AmpDh2 and AmpDh3 (Juan, *et al.*, 2006, Lee, *et al.*, 2013, Martinez-Caballero, *et al.*, 2013, Zhang, *et al.*, 2013). It also has a AmpG paralog, AmpP which we hypothesize is a second muropeptide transporter (Kong,

et al., 2010). This part of the research addresses the role of the permeases AmpG and AmpP in *P. aeruginosa* with regards to cell-wall recycling in *P. aeruginosa*.

AmpG (PA4393): AmpG has been identified in 134 distinctive genera of bacteria including pathogens such as *P. aeruginosa*, *Neisseria gonorrhoea*, *Serratia marcescens*, *Vibrio cholerae*, *Acinetobacter baumannii* and *Salmonella* species (Folkesson, *et al.*, 2005, Garcia & Dillard, 2008, Adin, *et al.*, 2009, Li, *et al.*, 2016). Most AmpG proteins were found to have 12-14 transmembrane (TM) domains (Li, *et al.*, 2016). The crucial role of AmpG in β -lactam resistance was realized for the first time upon its identification in *Enterobacter cloacae* (Korfmann & Sanders, 1989). *P. aeruginosa* AmpG has a particularly long sequence with 14 transmembrane spanning domains. A high degree of sequence conservation is observed amongst AmpG found in different bacteria. A previous study showed that *P. aeruginosa* AmpG can be successfully complemented by AmpG from other Gram-negative pathogens such as *Acinetobacter baumannii*, *Escherichia coli*, and *Vibrio cholera* (Li, *et al.*, 2016).

The vital role played by AmpG in muropeptide recycling modifies not just β -lactam resistance but also the pathogenicity. This has been the research focus regarding AmpG in *Neisseria* species (Garcia & Dillard, 2008, Woodhams, *et al.*, 2013). It was found that non-pathogenic strains of *Neisseria* sp. such as *N. sicca* and *N. mucosa* were more efficient at recycling their muropeptides (Chan & Dillard, 2016). Furthermore, replacing AmpG of pathogens such as *N. gonorrhoea* by its homolog from a human colonizer such as *N. meningitidis* or with AmpG from *E. coli* decreased the virulence of the pathogen (Chan & Dillard, 2016). The diminished pathogenicity after AmpG substitution was correlated with a reduced release of muropeptides and more efficient recycling (Garcia & Dillard, 2008, Chan & Dillard, 2016). Another example is *Bordetella pertussis* where the

causative agent of whooping cough, the tracheal cytotoxin, is a muropeptide (Goldman & Herwaldt, 1985, Luker, *et al.*, 1993). Specifically, it is composed of N-acetylglucosamine 1, 6 anhydro N-acetylmuramic acid tetrapeptide (Goldman & Herwaldt, 1985, Goldman & Cookson, 1988). The release of this tracheal cytotoxin into the host was depleted when the *B. pertussis ampG* gene was replaced by that of *E. coli* (Feunou, *et al.*, 2008). *ampG* is also one of the genes targeted during the construction of a live-attenuated vaccine for *B. pertussis* (Mielcarek, *et al.*, 2006). This reflects once again upon the fact that pathogenic bacteria, unlike in non-pathogens often have an inefficient muropeptide recycling due to a deficient AmpG.

In *P. aeruginosa*, AmpG is encoded by PA4393 and localized to the inner membrane and act as a permease for the muropeptides transport from periplasm into the cytoplasm (Kong, *et al.*, 2010, Perley-Robertson, *et al.*, 2016). Its role in β -lactam resistance was further proved when a decrease in MIC was noted upon the deletion of this gene (Kong, *et al.*, 2010, Zhang, *et al.*, 2010). This decrease was relevant not just in the lab reference strain PAO1, but in clinical strains as well wherein attenuating AmpG resulted in restoring the MIC to below CLSI breakpoints by blocking the expression of AmpC (Zamorano, *et al.*, 2011). Besides *P. aeruginosa*, the importance of AmpG as an activator of AmpC expression and resistance has been examined in *Xanthomonas campestris*, *Strenotophomonas maltophila*, *Enterobacter cloacae*, *Citrobacter freundii* (Korfmann & Sanders, 1989, Lindquist, *et al.*, 1993, Huang, *et al.*, 2010, Yang, *et al.*, 2013).

AmpP (PA4218): *P. aeruginosa* PA4218 encodes for a protein that was shown to be involved in β -lactam resistance in *P. aeruginosa* (Kong, *et al.*, 2010). Previous research in the lab showed that inactivating AmpP resulted in a sub-maximal β -lactamase

expression (Kong, *et al.*, 2010). This phenotype was restored to that of wild-type by *in-trans ampP* complementation. This indicated to us that AmpP plays a role in β -lactam resistance. Protein structure analysis also indicated that this is a permease with a Major Facilitator Superfamily domain. Localization studies using LacZ-PhoA fusions found that it lies in the inner membrane with ten TM spanning regions (Kong, *et al.*, 2010). Its role in regulating β -lactamase expression along with its activity as a permease and significant homology with *P. aeruginosa* AmpG led to the hypothesis that this protein may be involved in the cell-wall recycling pathway. AmpP is the second gene of a two-gene operon whose expression is found to be controlled by a transcriptional regulator AmpR independent of any β -lactam induction (Kong, *et al.*, 2010, Balasubramanian, *et al.*, 2012). Besides the research in our lab, AmpP was also found to be involved in pyochelin utilization which is one of the two siderophores found in *P. aeruginosa* (Michel, *et al.*, 2007, Cunrath, *et al.*, 2015).

Although it has been known that AmpG acts as a muropeptide transporter in *P. aeruginosa*, its specific role in cell-wall recycling has not been studied. Similarly, the role of AmpP in cell-wall recycling has not been explored. Thus, this research addresses the gap in knowledge regarding the function of these inner membrane permeases in cell-wall recycling. This study will compare the accumulation of the muropeptides in the parent reference strain PAO1 with its isogenic permease mutants.

3.3 Materials and Methods

3.3.1 Strains, media and growth conditions. *Pseudomonas aeruginosa* PAO1 and its derivatives (PAO Δ ampG, PAO Δ ampP, PAO Δ ampG Δ ampP) and *Escherichia coli* DH5 α

were used in this study. For *in vivo* homologous recombination, the yeast model *Saccharomyces cerevisiae* InvSC1 strain (Invitrogen™, Life Technologies, Carlsbad, CA, USA) was used (Shanks, *et al.*, 2006). *E. coli* and *P. aeruginosa* were cultured in Luria Bertani broth (5 g tryptone, 10 g sodium chloride, and 5 g yeast extract per liter) with supplements of 1.5% agar when needed at 37° C. For triparental mating experiments, *Pseudomonas* Isolation Agar (Difco) was used along with LB for *P. aeruginosa* selection. *S. cerevisiae* was cultured in YEPED media (Yeast extract-peptone-dextrose media: 20 g Bacto Peptone, 10 g yeast extract, and 20 g dextrose per liter) at 30 °C. Selection of yeast colonies with transformed pMQ30 was done using synthetic define agar-uracil media. For plasmid selection and maintenance, antibiotics at the following concentrations were used: gentamicin (Gm) 15µg/mL for *E. coli*, 75 µg/mL for *P. aeruginosa*, chloramphenicol (Cm) 10 µg/mL and kanamycin (Km) 20 µg/mL for *E. coli*.

3.3.2 Construction of *ampG* and *ampP* deletion mutants by homologous recombination. The deletions were constructed in *Pseudomonas aeruginosa* PAO1 genomic background (Holloway & Morgan, 1986). Upstream and downstream regions of *ampG* (PA4393) were amplified to generate what we refer to as P1 and P2. The P1 and P2 were produced by PCR using primers pairs LS_PA4393 UF, LS_PA4393 UR and LS_PA4393DF, LS_PA4393DR that gave amplicons of 986-bp and 991-bp, respectively. Similarly, for *ampP* (PA4218), primer pairs LS_PA4218 UF, LS_PA4218 UR and LS_PA4218 DF, LS_PA4218 DR were used to generate 997-bp and 926-bp P1 and P2, respectively. The amplified fragments were checked by PCR and its fidelity was determined by sequencing. The P1, P2 of *ampG* and *ampP* were transformed into *Saccharomyces cerevisiae* respectively, with a linearized (BamH1 digested) vector

pMQ30 to generate the spliced product (P3) (Shanks, *et al.*, 2006). PCR and agarose gel electrophoresis were used to screen the yeast colonies for the presence of the P3 following which yeast DNA was isolated from the positive clones. The recombinant construct was extracted from yeast and introduced in *E. coli*. The positive colonies were selected by their growth on gentamicin and the presence and fidelity of the P3 with the deleted target gene was checked by PCR and sequencing. The P3 constructs was conjugated into *P. aeruginosa* PAO1 independently by triparental mating using *E.coli*/pRK2013 and pRK600 as helper strains (Figurski & Helinski, 1979, Finan, *et al.*, 1986). The single and double crossover products were confirmed by Gm sensitivity followed by selection for loss of pMQ30 plasmid through sucrose resistance (Oldenburg, *et al.*, 1997, Shanks, *et al.*, 2006). The integration of the DNA fragment in the chromosome and the loss of the target genes were verified by PCR and sequencing. The *ampP* deletion (plasmid with P3 fragment) was also introduced in the *ampG* deletion to create the permease double deletion mutant, PAO Δ *ampG* Δ *ampP*.

Table 3. 1: Strains, plasmids and primers used in this study.

Strains	Relevant phenotype and genotype	Reference/ Source
<i>Escherichia coli</i>		
DH5 α	F- Φ 80/ <i>lacZ</i> Δ M15 Δ (<i>lacZYA argF</i>)U169 <i>deoR recA1 endA1 hsdR17</i> (rk-mk+) <i>phoA supE44</i> λ - <i>thi-1 gyrA96 relA1</i>	New England Biolabs
<i>Saccharomyces cerevisiae</i>		
INVSc1	<i>MATa/MATα leu2/leu2 trp1-289/trp1-289 ura3-52/ura3-52 his3-Δ1/his3-Δ1</i>	Invitrogen
<i>Pseudomonas aeruginosa</i>		
PAO1	Wild-type	(Holloway, <i>et al.</i> , 1979)
PAO Δ <i>ampG</i>	PAO1 containing in-frame deletion of <i>ampG</i>	This study
PAO Δ <i>ampP</i>	PAO1 containing in-frame deletion of <i>ampP</i>	This study
PAO Δ <i>ampG</i> Δ <i>ampP</i>	PAO1 containing in-frame deletions of <i>ampG</i> and <i>ampP</i>	This study
PAO Δ <i>ampG</i> (pAmpG)	PAO Δ <i>ampG</i> containing <i>ampG</i> on plasmid pMQ72	This study

PAO Δ <i>ampP</i> (pAmpP)	PAO Δ <i>ampP</i> containing <i>ampP</i> on plasmid pMQ72	This study
Plasmids		
pGEMT	TA cloning vector for PCR products; Ap ^R , ColE1 f1 ori lacZ α	Promega
pRK600	Cm ^R ; colE1 tra ⁺ RK2 mob ⁺ ; Helper plasmid for conjugation	(Figurski & Helinski, 1979)
pRK2013	Km ^R ; colE1 tra ⁺ RK2 mob ⁺ ; Helper plasmid for conjugation	(Finan, <i>et al.</i> , 1986)
pMQ30	Gm ^R ; colE1, oriT	(Shanks, <i>et al.</i> , 2006)
pSD51	Ap ^R ; A ~1.8-kb NheI-SacI fragment containing <i>ampG</i> ORF (<i>PA4393</i>) amplified from PAO1 genome using SD_ampG_FW and SD_ampG_Rev primers and cloned into pGEMT	This study
pSD57	Ap ^R ; A ~1.2-kb NheI-SacI fragment containing <i>ampP</i> ORF (<i>PA4218</i>) amplified from PAO1 genome using SD_ampP_FW and SD_ampP_Rev primers and cloned into pGEMT	This study
pSD55	Gm ^R ; The <i>ampG</i> ORF sub-cloned from pSD as an NheI-SacI fragment into pMQ72	This study
pSD61	Gm ^R ; The <i>ampP</i> ORF sub-cloned from pSD as an NheI-SacI fragment into pMQ72	This study
Primers		
LS_PA4393 UF	5'-GGAATTGTGAGCGGATAACAATTTTCACACAGGAAACAGCTCGAAGAAGCGATCGAGGTTCG-3'	This study
LS_PA4393 UR	5'-CGAATGCCGGCCTTTTTTCATTCTCGCCTAGCTAGCTAGGGGTAACCGTTCCGCAAAA-3'	This study
LS_PA4393 DF	5'-TTTTGCGGAACGGTTACCCCTAGCTAGCTAGGCGAGAATGAAAAAGGCCGGCATTTCG-3'	This study
LS_PA4393 DR	5'-CCAGGCAAATTCTGTTTTATCAGACCGCTTCTGCGTTCTGATGGAAACGTGCCCCACGG-3'	This study
LS_PA4218 UF	5'-GGAATTGTGAGCGGATAACAATTTTCACACAGGAAACAGCTGACCTGCATGGCCTGATCGG-3'	This study
LS_PA4218 new UR	5'-GCCTATCGGCAGCGCCTCACGCTAGCTCAAGCATGGTGGTCTCCGGTGAC-3'	This study
LS_PA4218 new DF	5'-GTCACCGGAGACCACCATGCTTGAGCTAGCGTGAGGCGCTGCCGATAGGC-3'	This study
LS_PA4218 DR	5'-	This study

	CCAGGCAAATTCTGTTTTATCAGACCGCTTC TGCGTTCTGATCTCGGCGTGGAGCGTATC-3'	
SD_PA4218_Fw_Nhe1	5'- GGGCTAGCAGGAGAGACCTCACCTGATCC TCT-3'	This study
SD_PA4218_Rev_Sac 1	5'- GGGAGCTCGCGGGAGAGGCGGCATCCGT- 3'	This study
SD_PA4393_Fw_Nhe1	5'- GGGCTAGCAGGAGATTGCGCGAGGAAGGC GTTCT-3'	This study
SD_PA4393_Rev_Sac 1	5'- GGGAGCTCGCGATGGCCGACTGAGGTCCG TGC-3'	This study

3.3.3 Construction of complementing plasmids. DNA fragments from *P. aeruginosa* PAO1 with *ampG* (~1.78 kb) and *ampP* (~1.2 kb) were PCR amplified using primer pairs SD_PA4393_Fw_Nhe1 and SD_PA4393_Rev_Sac1 and SD_PA4218_Fw_Nhe1 and SD_PA4218_Rev_Sac1, respectively (Table 2.1). The PCR amplified products were cloned into pGEMT (Promega Corporation, USA) using manufacturers protocol to generate plasmids pSD51 and pSD57, respectively. The fidelity of the PCR amplified product was confirmed by sequencing. The fragments carrying *ampG* and *ampP* were moved into a broad host range pMQ72 plasmid as *NheI*-*SacI* fragments, downstream of an inducible *P_{lacUV5}* promoter to generate plasmids pSD55 and pSD62, respectively. Henceforth, these plasmids are referred to as pAmpG and pAmpP. These expression plasmids were then introduced into wild-type PAO1, PAO Δ *ampG*, and PAO Δ *ampP* deletion mutants by electroporation and gentamycin resistant colonies were selected.

3.3.4 Growth curves. *P. aeruginosa* PAO1 and its derivatives were grown overnight at 37°C in LB broth with or without antibiotics. Overnight cultures were washed with sterile 0.85% NaCl (wt/vol) solution to remove spent media. Cultures were diluted in fresh LB broth to obtain equal optical densities (OD₆₀₀) of 1. From this culture, they were diluted

again to a starting OD₆₀₀ of 0.05. Growth was monitored by determining absorbance at 600 nm using BioTek Synergy HT (Winooski, VT, USA) plate reader for 16–18 h at 37°C.

3.3.5 Determination of minimum inhibitory concentration (MIC). The MIC was determined using the E-test (BioMerieux) (Melvin P. Weinstein, 2018). Briefly, overnight cultures of bacteria were diluted to an OD of 0.02-0.2 and spread on an LB-agar plate. An E-strip which contains antibiotics at an increasing concentration along its length was placed on the plate. The MIC was determined by the zone of clearance on the plate after 16-18 hr incubation at 37 °C.

3.3.6 Quantifying β -lactamase activity. β -lactamase activity was quantified as described previously (O'Callaghan, *et al.*, 1972, Kong, *et al.*, 2005). Briefly, cells in LB broth at an OD₆₀₀ of 0.5-0.6 were treated with 100 μ g/ml Penicillin G for two hours at 37 °C. The cells were then harvested, OD normalized, and lysed with BugBuster Protein Extraction Reagent (Novagen, WI) and r-Lysozyme (Novagen, WI) and treated with Benzonase nuclease (Novagen,WI). The amount of β -lactamase was quantified in the soluble fraction by determining hydrolyzing activity on nitrocefin (Oxoid, England). Protein concentrations in the samples were determined by Bradford assay. Enzyme activity was expressed as milliunits of β -lactamase (nanomoles of chromocef hydrolyzed per minute per microgram of protein).

3.3.7 Release of muramyl peptides from whole cell extracts. *P. aeruginosa* (wild type; PAO1 and mutants; PAO Δ *ampG*, PAO Δ *ampP*) was grown until late log phase. The culture was harvested by centrifugation at 11, 000 *g* for 20 min and the supernatant discarded. The cell pellet was resuspended gently in cold shrinking solution (20% sucrose, 1.2 mM EDTA, 30 mM Tris, pH 8) and left with shaking at 4° C for 10 min. This

was centrifuged followed by resuspension of the pellet in ice cold water. The suspension was kept at 4° C for 10 min, and then centrifuged at 11,000 g for 20 min and the supernatant discarded. The pellet was then boiled to quench enzyme activity and sonicated to ensure complete release of muropeptides. The sample was filtered using 30 KDa molecular weight cut off mini-column. The remaining solution was concentrated through speed vacuum at 50° C and used for LC/MS analysis. Dionex Ultimate 3000 Rapid Separation UPLC system coupled to Bruker MicrOTOF-Q II Mass spectrometer was used for the analysis (Lee, *et al.*, 2013).

3.3.8 Release of muramyl peptides from periplasm. Periplasmic extraction was done using osmotic shock, as previously described with minor modifications (Nossal & Heppel, 1966). The culture was grown until OD₆₀₀ 1.2. The bacteria was harvested and suspended in buffer containing Tris-Cl (pH-7.4) and magnesium chloride 200 mM. This suspension was kept under rotation for 15 minutes at room temperature and re-harvested again. The culture was then re-suspended in ice-cold water and kept under shaking at 4 °C. The culture was harvested again, and the supernatant collected. This contains the periplasmic proteins. For our analysis by LC/MS, this was filtered through 30KDa mini-column and the filtrate was collected. The filtrate was boiled to quench any enzyme activity and concentrated using a speed-vacuum. This sample was analyzed by LC/MS.

3.3.9 Detection of muropeptides by liquid chromatography/mass spectrometry. The conditions used for LC/MS have been previously developed for muropeptide analysis (Lee, *et al.*, 2013). Briefly, the separation was done using a Dionex Ultimate 3000 Rapid Separation UPLC system equipped with a Dionex Ultimate 3000 autosampler and a Dionex Ultimate 3000 photodiode array detector. Separations were

performed on a Dionex Acclaim™ PolarAdvantage II C18 column (3 μm, 120 Å, 2.1 mm i.d. × 150 mm). The mobile phase consisted of A = 0.1% formic acid in water; B = 0.1% formic acid in acetonitrile. This was coupled with a Bruker MicrOTOF-Q II quadrupole time-of-flight hybrid mass spectrometer. The Bruker electrospray ionization source was operated in the positive ion mode.

3.3.10 Statistical analyses. All data were analyzed for statistical significance using the Student's t-test on GraphPad or Analysis of Variance (ANOVA) with post-hoc testing when appropriate.

3.4 Results and Discussion

This study was done by extracting cell-lysates during log growth phase of bacteria and determining the relative levels of individual muropeptide. Instead of radioactivity which was previously used to study muropeptide levels, a liquid chromatography/mass-spectrometry approach is utilized here. This allowed us to identify muropeptides at the micro molar concentrations as well as to pin-point subtle changes in the profile of PG fragments between different strains. This approach of muropeptide analysis was however only possible as synthetic muropeptides were available (Hesek, *et al.*, 2009).

3.4.1 Growth analysis of mutant strains. The PAOΔ*ampG*, PAOΔ*ampP* and PAOΔ*ampG*Δ*ampP* mutants exhibited no discernible phenotype in growth compared to the parent PAO1 when tested in LB media over 16-18 hours (Figure 3.1). This demonstrates that the permeases in cell-wall recycling are not essential for growth in *P. aeruginosa*.

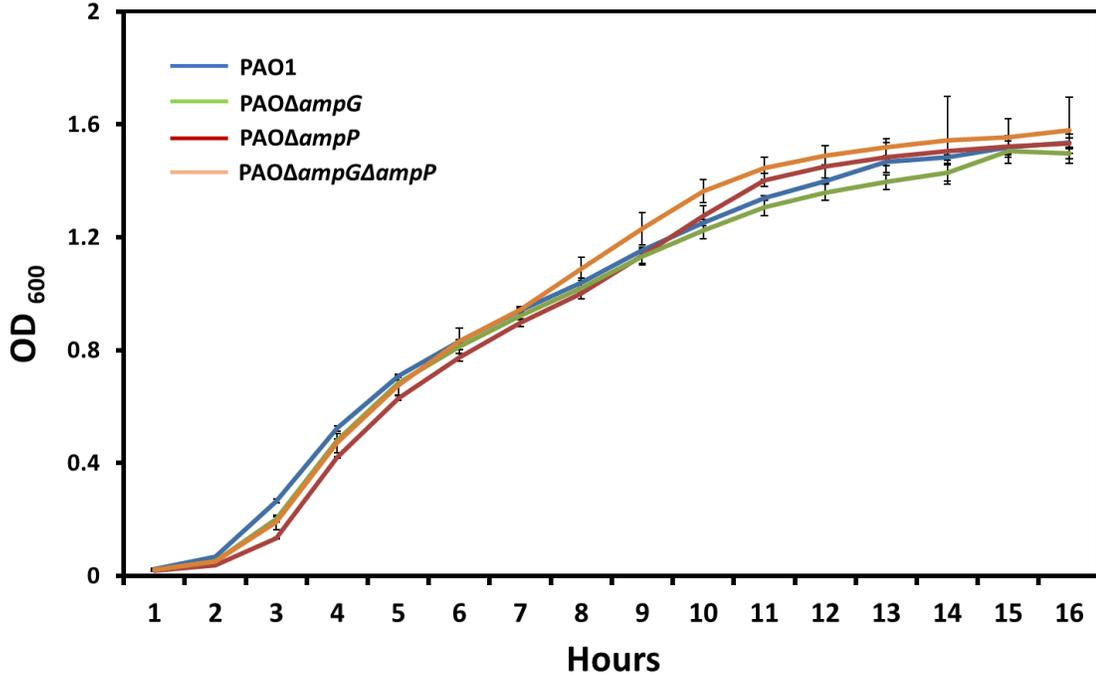

Figure 3. 1. Growth curve analysis of mutants. Growth curves of PAO1 and the mutants PAOΔampG, PAOΔampP and PAOΔampGΔampP was analyzed in LB broth at 37 °C over 16 hours. No difference was seen in the growth of mutants in this media.

3.4.2 MIC of β-lactams is altered in ampG deletion. To investigate the role of *ampG* in *P. aeruginosa*, precise in-frame deletion of the gene was generated. The susceptibility of selected antibiotics was compared with that of the parent strain PAO1. Antibiotics were chosen based upon two criteria. This included firstly the antibiotics which are predominantly used in the clinical setting in case of a multi-drug resistant infection. These include a combination therapy with aminoglycosides, fluoroquinolones, and fosfomycin (Samonis, *et al.*, 2012, Tangden, 2014). Secondly, as the role of *ampG* in resistance is manifested through cell-wall recycling and AmpR, the antibiotics that have

previously shown a differential MIC in PAO Δ *ampR* were selected (Balasubramanian, *et al.*, 2013).

The MIC for the β -lactams which include aminopenicillins (ampicillin) cephalosporins (ceftazidime and cefoxitin) and carbapenems were reduced in the absence of *ampG* when compared with the wild-type PAO1. This phenotype was restored to the wild-type levels upon *in-trans* complementation. However, the MIC of ceftazidime which is a weak inducer of AmpC was unaltered. Interestingly, the MIC to one of the last-resort antibiotics for resistant infection, fosfomycin, was also decreased in PAO Δ *ampG* (Table 3.1).

3.4.3 β -lactamase expression is reduced in *ampG* deletion mutants. Previously, a study in our lab had shown that deletion of *ampG* resulted in the production of sub-maximal levels of β -lactamase (Kong, *et al.*, 2010). As an insertional inactivation mutant had been used in the earlier study, we verified our observations with a precise deletion. Upon comparing the results with PAO1, it was found that PAO Δ *ampG* had significantly ($p < 0.05$) decreased levels of β -lactamase expression.

Table 3.1. Susceptibility profiles of PAO Δ *ampG*, PAO Δ *ampP* and PAO Δ *ampG* Δ *ampP*.

Antibiotics	Minimum Inhibitory Concentration (μ g/ml)					
	PAO1	PAO Δ <i>ampG</i>	PAO Δ <i>ampP</i>	PAO Δ <i>ampG</i> (pAmpG)	PAO Δ <i>ampP</i> (pAmpP)	PAO Δ <i>ampG</i> Δ <i>ampP</i>
Ampicillin	>256	32-64*	>256	>256	>256	16-32*
Ceftazidime	1.5	1.5	2-1.5	2	1.5	2
Cefoxitin	>256	64*	>256	>256	>256	64*
Imipenem	2-1.5	.38-.5*	2	2	1.5	.38*
Doripenem	0.25	0.19	0.19	0.125	0.125	.25
Meropenem	0.38	0.38-0.5	0.25	0.38-0.5	0.38-0.5	.5
Ciprofloxacin	0.25-0.5	0.25	0.25	0.25	0.5	.19
Ofloxacin	2	1	1.5	1.5	2	1
Fosfomycin	32	8*	32	24-16	16	8-16
Colistin	0.75	0.75	0.75	0.75	1.5	0.75-1.5
Trim-sox	4	3	6	4	3	4

*Significance was noted using student's T-test (PAO1 vs mutants, $p < 0.05$)

3.4.4 MIC and β -lactamase expression is unaltered in *ampP* deletion. To investigate the role of *ampP* in *P. aeruginosa*, a precise in-frame deletion of the gene was generated. Previously, a study had shown that upon insertional inactivation of *ampP*, the β -lactamase expression was decreased (Kong, *et al.*, 2010). However, no change was found in the MIC of β -lactams (Table 2.1). For induction of β -lactamase similar conditions as that for *ampG* strains were used. No significant differences were found in the β -lactamase expression levels of *ampP* deletion when compared with the wild-type PAO1.

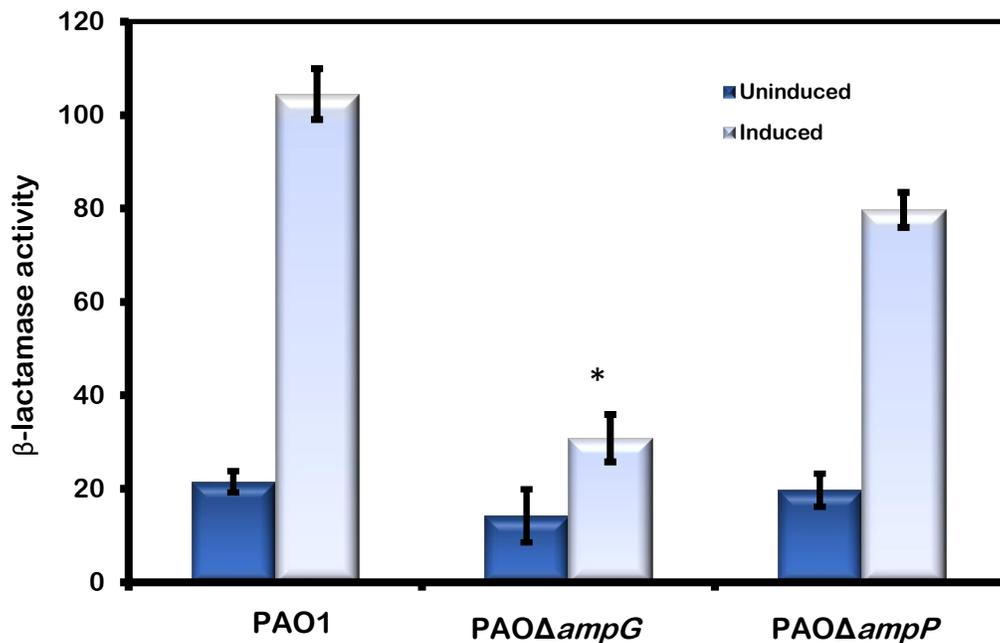
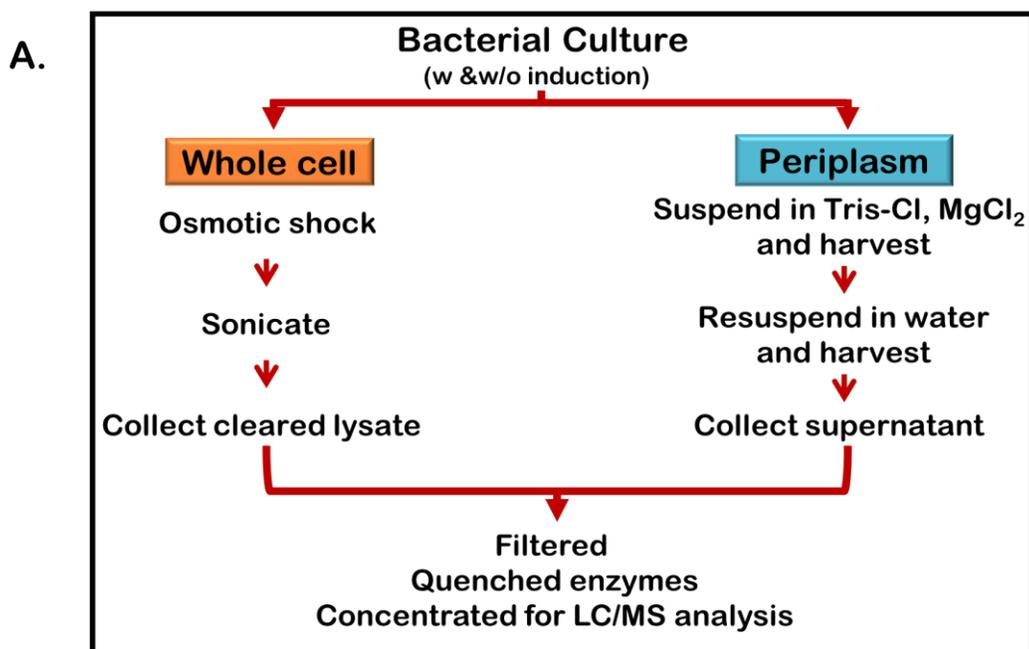

Figure 3.2. β -lactamase expression of PAO1 and permease mutants. The β -lactamase activity was quantified for PAO1, PAO Δ *ampG*, and PAO Δ *ampP* in the presence and absence of a β -lactam (Penicillin 100ug/ml). **p*-value = 0.004 for β -lactamase activity in PAO Δ *ampG* vs PAO1 induced, as determined by unpaired t-test.



B.

		<p>GlcNAc-1,6 anhydro MurNAc peptide</p>
		<p>1,6 anhydro MurNAc peptide</p>
		<p>GlcNAc-MurNAc peptide</p>
		<p>Cross linked muropeptides GlcNAc 1,6 anh MurNAc peptides GlcNAc MurNAc peptides</p>

Figure 3.3. (A) A brief scheme of the muropeptide extraction protocol. **(B)** The structures of muropeptides. As found in *P. aeruginosa* as per our previous study are listed here (Lee, *et al.*, 2016).

3.4.5 Muropeptide profile of whole-cell extract in mutant strains. In this study, we compare the trend and profile of muropeptides in the permease mutant strains with the parent wild-type PAO1. We used LC/MS was used to qualitatively analyze the muropeptides from the bacterial lysate that was extracted during the late-log phase of growth. Standards included synthesized muropeptides and were run with every set of samples to ensure the LC column sensitivity and specificity (Figure 3.3). The trend of individual and total muropeptides were compared between *ampG*, *ampP* and the double permease deletion; *PAOΔampGΔampP* with the wild-type PAO1.

It was found that across the mutant strains, the relative levels of a group of muropeptide such as disaccharide-peptide, monosaccharide peptides and larger muropeptides which include tetra-saccharide and the cross-linked peptides were not significantly different (Figure 3.4). Besides *ampG*, we also studied the muropeptide levels in *ampP* deletion mutant. Given its homology to *E. coli* AmpG (41%), we hypothesize that this permease acts as a muropeptide transporter, possibly for the processed muropeptides from the cytoplasm to the periplasm (Kong, *et al.*, 2010). When compared with the wild-type PAO1 and *ampG* deletion, it showed a lower relative level of disaccharide-peptides and a higher level of monosaccharide-peptides. The levels of the larger saccharide including the cross-linked are similar in both the strains (Figure 3.4).

The profile of muropeptide in the double deletion *PAOΔampGΔamp* mutant was similar to *ampP* deletion. The relative levels of disaccharide were low when compared with the PAO1. The levels of monosaccharide muropeptides were higher than PAO1 and similar to that of *ampP* deletion (Figure 3.4).

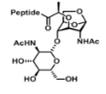
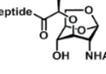
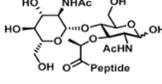
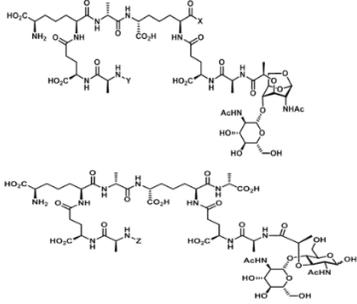
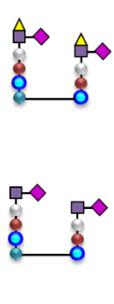
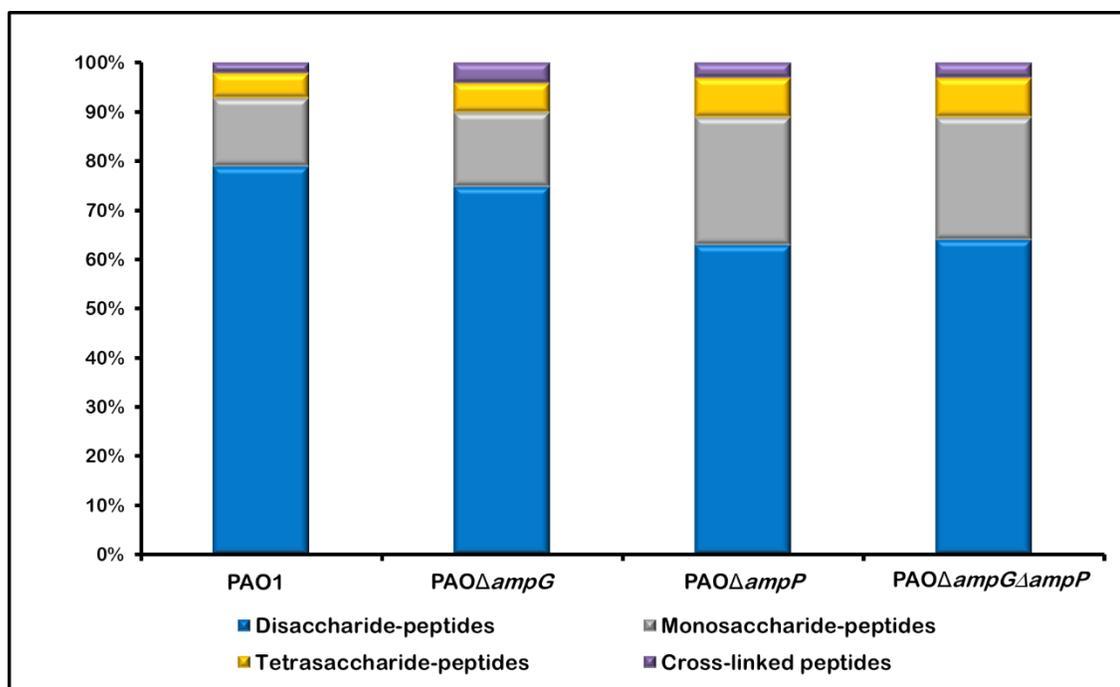

Figure 3. 4. Relative levels of muropeptides in whole-cells. The muropeptides extracted from whole cells. The area of individual muropeptides was calculated using area- under-the curve. They were grouped according to their saccharide backbone and compared across the strains. The disaccharides-peptide ranged from 0-4 amino acids i.e. no peptide to tetrapeptide moieties were found. Monosaccharide peptides include tri- and tetrapeptides. Tetrasaccharide peptides included tri- and tetrapeptides. Crosslinked peptides detected were tri- and tetrapeptides, with reduced ends.

3.4.6 Muropeptide profile of periplasmic extract in mutant strains. As AmpG is a permease that localizes to the inner membrane and imports muropeptides from the periplasm to the cytoplasm, the profile of muropeptides in the periplasm was analyzed. The expectation was that most of the muropeptides would be unprocessed by cytoplasmic enzymes. In accordance with this most of the muropeptides in the periplasm were disaccharides (Figure 3.5). The major products in all the strains for the periplasmic cell-extract were the GlcNAc 1, 6 anhydroMurNAc without any peptides. This could be due to the action of the periplasmic AmpDh2 and AmpDh3 amidases which cleave the

peptide chain. Although these enzymes have been noted to favor the full-sacculus, they also retain activity on the PG fragments (Zhang, *et al.*, 2013). There was no significant difference between the individual muropeptides on comparing the single permease deletion mutant strains PAO Δ *ampG* or PAO Δ *ampP* with PAO1 (Figure 3.5). However, deletion of both *ampG* and *ampP* permeases resulted in lowering the levels of disaccharide- muropeptides. There was a minor presence of monosaccharide peptides in the periplasm; namely the 1, 6 anhydro MurNAc tri- and tetrapeptides when compared with that seen in whole-cell extracts (Figure 3.6). This concurs with the hypothesis that the major or predominant *N*-acetylglucosaminidase enzyme lies in the cytoplasm, also known as NagZ. However, in agreement with our previous observation of monosaccharides in the periplasm, there may be a periplasmic *N*-acetylglucosaminidase (Lee, *et al.*, 2016). Indeed, this was recently found to be the case for *S. enterica* where one of the PG hydrolyzing enzymes of the flagellar operon was found to have this activity (Herlihey, *et al.*, 2014).

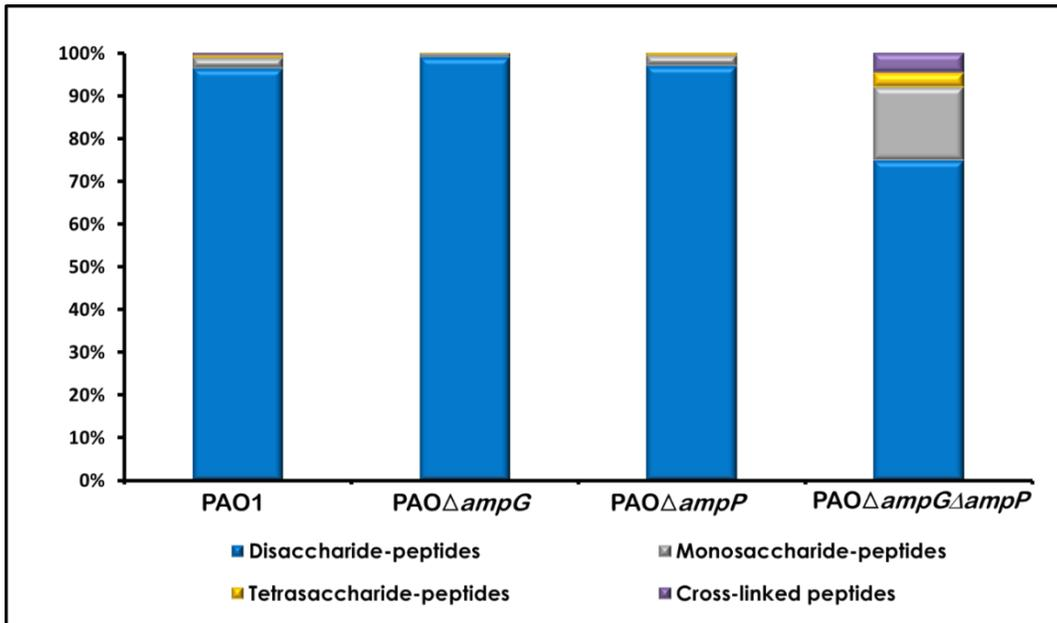

Figure 3.5. Relative levels of muropeptides in periplasm. Muropeptides extracted from the periplasm consisted primarily of disaccharide-peptides across all the strains. Higher levels of monosaccharides were detected in *PAOΔampGΔampP*.

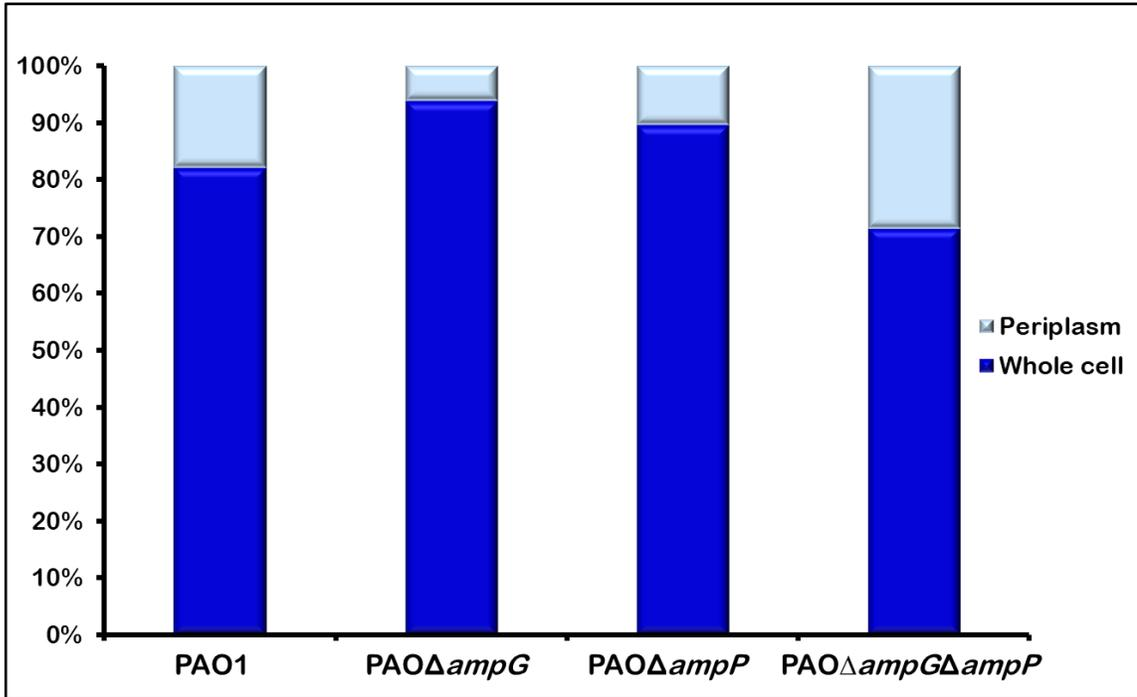

Figure 3.6. Relative levels of monosaccharides in whole-cell and periplasm. 1, 6 anhydro MurNAc peptides tri and tetrapeptide were monosaccharides detected in both whole cell and periplasmic extracts. The levels of monosaccharides in the periplasm were lower when compared to those in the whole-cell extracts.

Similarly, for the larger muropeptides such as the tetra-saccharide peptides and the cross-linked PG fragments, minute quantities were detected in the mutant strains as well as in PAO1. When compared across strains for the whole-cell and the periplasmic extract, levels of the larger peptides were found to be higher (Figure 3.6). This may be due to the sample preparation method as sonication is used to isolate the whole-cell extracts which may result in displacing the larger muropeptides that may otherwise be stuck with the sacculus (Lee, *et al.*, 2016).

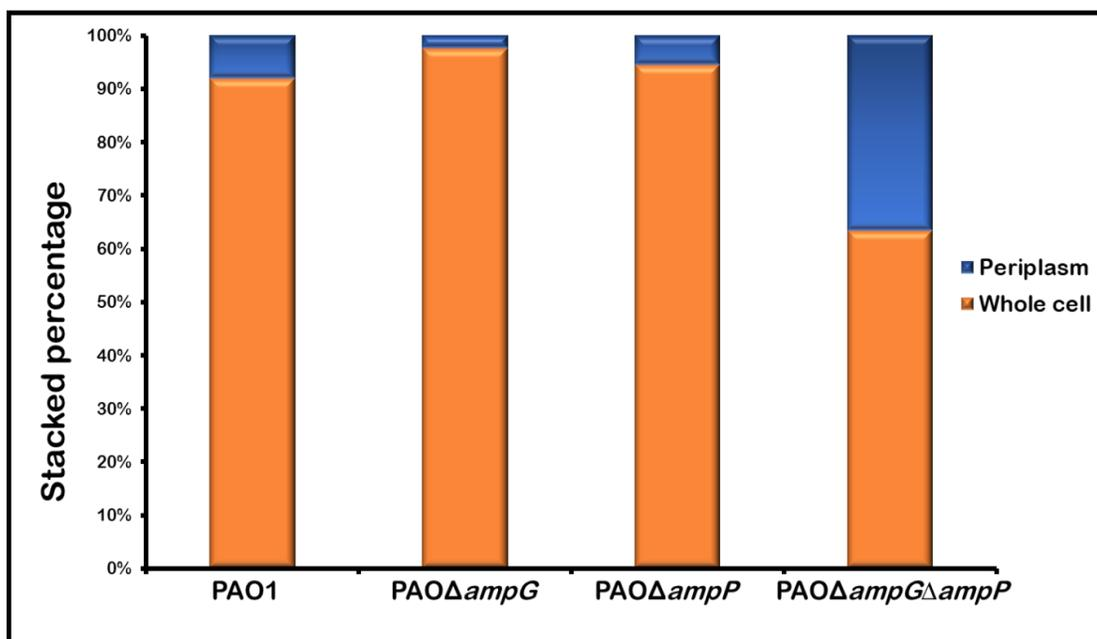

Figure 3.7. Relative levels of larger muropeptides in whole-cell and periplasm. The larger peptides included tetrasaccharides tri-tri peptide and tetra-tetra peptides. The cross-linked peptides included disaccharides- tri-tri peptides and tetra-tetra peptides. Relatively higher levels were found in the whole cell preparation.

3.4.7 Decrease of disaccharide in PAO Δ *ampP* periplasm and increase presence of disaccharide in PAO Δ *ampG* periplasm. As we had the levels of muropeptides in the whole-cells and the levels of muropeptides in the periplasm, by subtraction analyses, the muropeptides in the cytoplasm was inferred. Upon comparing the different groups of muropeptides, it was found that decrease in accumulation of disaccharides was found in *ampP* deletion in the periplasm and an increase of disaccharides was detected in the *ampG* deletion suggesting that the permease encoded

by these genes may play a role in import of these muropeptides into the periplasm and cytoplasm, respectively (Figure 3.8). The levels of monosaccharide and larger muropeptides remain similar in all the strains.

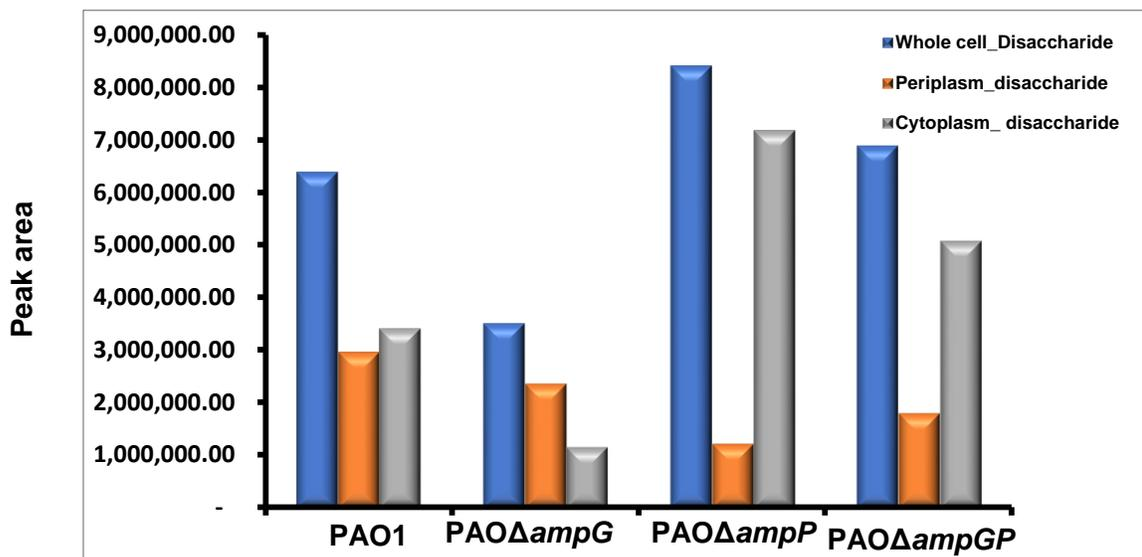

Figure 3. 8. Comparison of disaccharide levels in sub-cellular fractions. The levels of disaccharide muropeptides were calculated in the whole-cell and periplasmic fraction. The levels of muropeptides in the cytoplasm were obtained by subtracting the values of muropeptides in periplasm from whole-cell. It was found that deletion of *ampG* showed a significant accumulation of muropeptides in the periplasm compared to the wild-type PAO1. The levels of disaccharide-muropeptide in the *ampP* deletion strain were decreased compared to PAO1. This was also seen upon in the double-deletion strain.

3.5 Concluding Remarks

Cell-wall recycling has been researched since the 1960-70s (Chaloupka, *et al.*, 1962, Boothby, *et al.*, 1973, Beck & Park, 1976). Early studies were performed mostly on *E. coli* or *C. freundii* as model systems. Most of these studies conducted pulse-chase experiments with H³-GlcNAc or H³-DAP which was incorporated in the cell-wall and henceforth recycled and detected in spent media or in cell-fractions (Glauner, *et al.*,

1988, Dietz, *et al.*, 1997). Muropeptide detection without any radioactivity has been performed only recently (Borisova, *et al.*, 2016, Lee, *et al.*, 2016). *Pseudomonas aeruginosa*, a portentous opportunistic pathogen exhibits an exceptional capability to resist antibiotic treatment. In this study we explored the link of β -lactam resistance with the two permeases AmpG and AmpP in cell-wall recycling by comparing the wild-type PAO1 with isogenic single and double-deletion permease mutants. The involvement of the permeases in antibiotic resistance was investigated by E-test and β -lactamase assay. We also looked at the levels of muropeptides *in vivo* in *P. aeruginosa* without employing any radioactivity. Studying muropeptides *in vivo* poses its own challenges. Muropeptides in the bacteria are continuously being turned –over and hence obtaining a snapshot of this dynamic process is technically challenging. One of the main technical difficulties, while quantifying the PG fragments at a certain phase of bacterial growth, is quenching the recycling enzymes namely the amidases, lytic transglycosylases, and the *N*-acetylglucosaminidases that are usually involved in muropeptide processing. We find that quenching enzyme activity to a large extent can be obtained by boiling the cell-extracts without lessening the muropeptide levels.

Previous studies involving non-pathogenic and pathogenic bacteria suggested that *ampG* plays a role in cell-wall recycling as a permease (Park, 1993). It has also been shown that pathogenic bacteria such as *B. pertussis* and *N. gonorrhoea* have an inefficient AmpG and when compared with non-pathogens such as *E. coli* (Chan & Dillard, 2016). Both AmpG and AmpP are permeases in *P. aeruginosa* that may play a role in cell-wall recycling. It is shown here that the presence of these permeases is not essential for the growth of the bacteria in a rich medium. Since the elucidation of recycling process and its connection to β -lactamase already that AmpG is used to import

the muropeptides into the cytoplasm from the periplasm. Absence or deletion of this permease often results in increase release of muropeptides to extracellular milieu which triggers an inflammatory response in the host (Garcia & Dillard, 2008). However, this was not seen in *P. aeruginosa* wherein deletion of AmpG resulted in similar total levels of muropeptides as in PAO1. AmpP is unique to the Pseudomonads (Kong, *et al.*, 2010). In *P. aeruginosa*, overall trends of muropeptides were similar across the strains. One of the findings was that our periplasmic preparation yielded less monosaccharides compared to the whole-cell. This is in accordance with the localization of the enzymes in the recycling pathway and indicates that the method of extraction developed here can be used for studying periplasmic PG fragments. We also found increased relative levels of disaccharide in the periplasm of *ampG* deletion cells and the vice-versa for *ampP* and *ampG ampP* deletion. This confirms the earlier reports of AmpG importing disaccharides and also suggests that AmpP may play a role in transporting disaccharide-muropeptides from the cytoplasm into the periplasm. Although, a permease assay done with *E. coli* spheroplasts using fluorophore- conjugated GlcNAc-MurNAc showed that AmpG was the only muropeptide importer whereas AmpP was unable to import (Perley-Robertson, *et al.*, 2016). However, our speculation is that AmpP may be involved in export of disaccharide muropeptide rather than import.

Significantly diminished MIC for selected β -lactams and a decrease in β -lactamase expression was also found in the absence of *ampG*. This suggests also that the role of AmpG in antibiotic resistance is mediated specifically via the cell-wall recycling pathway and the activation of AmpR. Considering that AmpG is a key player in regulating antibiotic resistance and is not essential for growth, it has been developed as an alternate target for drug development (Collia, *et al.*, 2018).

3.6 Acknowledgements

This work was done in collaboration with Dr. Shahriar Mobashery, Dr. Mijoon Lee and Dr. Dusan Heseck at University of Notre Dame. We are grateful to Dr. Mobashery's lab, particularly Dr. Mijoon Lee for the LC/MS-MS, synthetic mucopeptide standards, as well as the discussions and critical analysis of the data towards this research. This work was supported by grant GM61629 from the NIH (to SM) and in-part by NSF IIP-1237818 [PFI-AIR: CRESTI/UCRC-Industry Ecosystem to Pipeline Research] (KM), Florida International University (FIU) Bridge Funding (KM), FIU Herbert Wertheim College of Medicine Graduate Assistantship (SD).

Chapter 4

Elucidating the role of *PA1085* in *Pseudomonas aeruginosa*

4.1 Abstract

Infections by the opportunistic human pathogen *Pseudomonas aeruginosa* are largely intractable due to the various resistance mechanisms demonstrated by this pathogen. One of the primary mechanisms of resistance towards a class of drugs known as β -lactams is the expression of a hydrolytic enzyme, AmpC. The coordinated activities of the *amp* genes regulate this enzyme's expression. NagZ is an *N*-acetyl β -D-glucosaminidase that plays a seminal role in regulating AmpC β -lactamase expression. LC/MS analyses of mucopeptides in PAO1 and the permease mutants eluded that there may be a periplasmic paralog of NagZ. *P. aeruginosa* genome analyses revealed the presence of PA1085 that had 31% identity with *S. enterica* FlgJ. We hypothesize that PA1085 is the *P. aeruginosa* periplasmic glucosaminidase. PA1085 is the fifth gene of a seven-gene operon and a precise in-frame deletion of *flgJ* (PA1085) was constructed using Gibson cloning. To verify if deleting a gene that is part of the flagellar operon disrupted motility, phenotypic assays such as swimming, swarming and biofilm were performed. For evaluating if *flgJ* plays a role in regulating β -lactam resistance the MIC was compared in *flgJ* deletion strains to the wild-type PAO1 using the Epsilometer test method. An enzyme assay was conducted to determine if assess whether FlgJ possesses β -N-acetylglucosaminidase activity. We found that flagellar-dependent swimming motility was decreased in the mutant strain, but flagellar and pili-dependent swarming motility were not significantly affected. Our experiments with the deletion strain did not show any differences in the MIC for selected antibiotics. Deletion of PA1085 also did not alter the β -N-acetylglucosaminidase enzyme activity in whole-cell.

4.2 Introduction

Pseudomonas aeruginosa, an opportunistic, nosocomial pathogen is associated with serious and challenging infections in immunocompromised individuals (Lang, *et al.*, 2004, Sadikot, *et al.*, 2005). In cystic fibrosis patients, with an increase in age, there is a steady decline of lung function and an increase in *P. aeruginosa* colonization (Koch & Hoiby, 1993, Gisin, *et al.*, 2013). *P. aeruginosa* infections can at times be resolved with monotherapy but it can also range to highly recalcitrant and deadly episodes. Often for treatment of serious infections, a combination therapy of two or more anti-pseudomonal agents such as aminoglycosides, fluoroquinolones, and β -lactams is recommended (Flume, *et al.*, 2009, Fothergill, *et al.*, 2012). The underlying factors for the life-threatening infections are the arsenal of virulence factors and the extraordinary innate and acquired antibiotic resistance mechanisms exhibited by this pathogen (Lister, *et al.*, 2009, Gellatly & Hancock, 2013). One of the predominant mechanisms of β -lactam resistance is the expression of chromosomally-encoded AmpC β -lactamase and its regulation by the global transcriptional factor, AmpR (Lodge, *et al.*, 1990, Lodge, *et al.*, 1993, Kong, *et al.*, 2005). The activity of AmpR as a resistance determinant is further influenced by the products of the cell-wall recycling pathway, known as muropeptides (Wiedemann, *et al.*, 1998, J. F. Fisher, 2015, Lee, *et al.*, 2016, Lee, *et al.*, 2016, Dik, *et al.*, 2017, Dhar, *et al.*, 2018).

Previously, our analyses by liquid chromatography/mass spectrometry identified over 20 muropeptides in *P. aeruginosa* (Lee, *et al.*, 2016). Muropeptides are composed of *N*-acetylglucosamine-*N*-acetylmuramic acid with a peptide side chain (L-Ala- γ -D-Glu-*meso*-diaminopimelic acid [DAP]-D-Ala-D-Ala) and are created whenever the bacterial cell divides or elongates and its components are recycled for biogenesis (Glauner, 1988).

The muropeptides detected by our analysis include disaccharide-peptides such as *N*-acetylglucosamine *N*-acetylmuramic acid with peptide side chains ranging from zero to five amino acids. Both reduced and non-reduced saccharides were detected (Lee, *et al.*, 2016). Monosaccharides detected include *N*-acetylmuramic acid with peptide side chains. In addition, larger peptides such as cross-linked di- and monosaccharides were also detected (Lee, *et al.*, 2016). In addition to elucidating the structural details of the muropeptides, we were also able to distinguish the GlcNAc pentapeptide and 1,6 anhydroMurNAc pentapeptides as activating effectors of AmpR (Lee, *et al.*, 2016, Dik, *et al.*, 2017).

Recycling of muropeptides occurs through the combined action of numerous genes dedicated to this pathway (Park & Uehara, 2008, Johnson, *et al.*, 2013). The groups of enzymes include lytic transglycosylases, amidases, permeases, *N*-acetylglucosaminidases and penicillin-binding proteins (Park, 1993). The muropeptides are translocated into the cytoplasm through permease AmpG (Jacobs, *et al.*, 1997). NagZ *N*-acetylglucosaminidase activity in the cytoplasm leads to the formation of 1, 6 anhydroMurNAc peptides which have been identified as the AmpR effectors (Jacobs, *et al.*, 1994, Dietz, *et al.*, 1997, Lee, *et al.*, 2016, Dik, *et al.*, 2017). AmpD amidase cleaves the peptide chain from the muropeptides (Carrasco-Lopez, *et al.*, 2011, Zhang, *et al.*, 2013). Upon β -lactam induction, loss of *nagZ* is associated with a decrease in *ampC* expression whereas loss of *ampD* is associated with an increase in *ampC* expression (Jacobs, *et al.*, 1995, Juan, *et al.*, 2005, Juan, *et al.*, 2006, Asgarali, *et al.*, 2009, Lee, *et al.*, 2009).

Locus Tag	<i>P. aeruginosa</i> PA1085	
	% Identity	% Similarity
<i>S. enterica</i> FlgJ	31	46
<i>P. aeruginosa</i> NagZ	20.7	32.9

Table 4.1. Protein homology between *S. enterica* and *P. aeruginosa* FlgJ. *S. enterica* data was obtained from NCBI. *P. aeruginosa* sequence was obtained from Pseudomonas website (Winsor, *et al.*, 2016). Identity was computed using CLUSTAL W2 “pairwise sequence alignment”.

Therefore, NagZ is established as an antibiotic target and small molecule inhibitors of NagZ have been synthesized which impair β -lactam resistance (Balcewicz, *et al.*, 2009, Yamaguchi, *et al.*, 2012, Acebron, *et al.*, 2017). During our analysis of *P. aeruginosa* muropeptides, the NagZ products 1, 6 anhydroMurNAc peptides were detected in the periplasm (Lee, *et al.*, 2016, Lee, *et al.*, 2016). This suggested the existence of a novel periplasmic *N*-acetylglucosaminidase. A periplasmic *N*-acetylglucosaminidase FlgJ had been detected in *Salmonella* sp. (Herlihey, *et al.*, 2014). Bioinformatics analysis of the *P. aeruginosa* genome with 31% identity to *S. enterica* FlgJ (Table 4.1). Furthermore, sequence alignment of *P. aeruginosa* FlgJ and *S. enterica* FlgJ shows that the catalytic residue (Glutamate 184) is conserved (Figure 4.1).

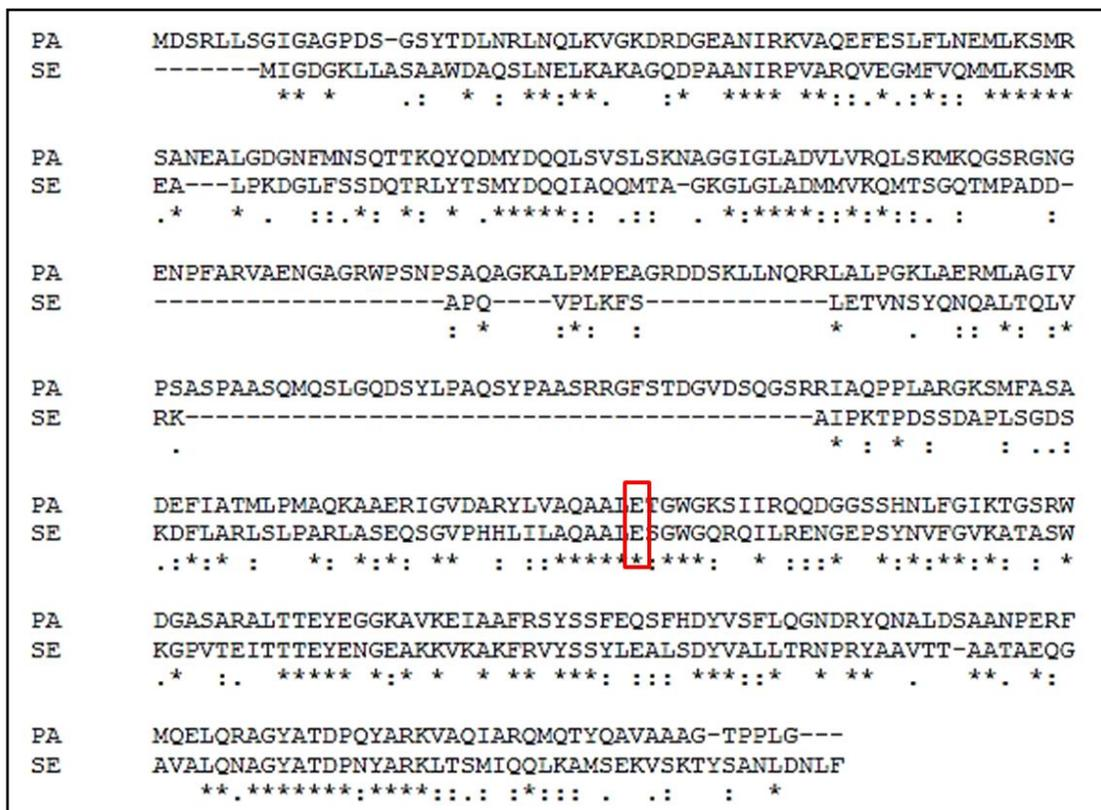

Figure 4. 1. Amino acid sequence alignment of PA1085/FlgJ with *S. enterica* FlgJ (Lee, *et al.*, 2016). Residues in the red box denote the Glu residues which are predicted as the catalytic acid/base residues in the respective enzymes. Protein alignment was done using CLUSTAL W2 (Winsor, *et al.*, 2016).

The synthesis and assembly of the flagellar system have been best investigated in *Salmonella* species (Aizawa, 1996, Apel & Surette, 2008). The C-terminal domain of FlgJ has a peptidoglycan lytic activity whereas the N-terminal domain is required for proper flagellar assembly (Nambu, *et al.*, 1999, Hirano, *et al.*, 2001). FlgJ is part of the flagellar biosynthesis operon in *P. aeruginosa* (Dasgupta, *et al.*, 2003). The flagellar biosynthesis genes are clustered in three regions on the PAO1 genome (Dasgupta, *et al.*, 2003). Region I comprises of genes that encodes proteins which build the flagellar structure (Dasgupta, *et al.*, 2003). Region II encodes for the accompanying regulatory components whereas Region III encodes for proteins which help in export of the flagella

and other chemotaxis regulatory factors (Dasgupta, *et al.*, 2003). FlgJ is encoded by the fifth gene of a six gene operon *flgF-flgG-flgH-flgI-flgJ-flgK* found in Region I. All the other genes in this operon encode structural components of flagella whereas FlgJ is hypothesized to act as a peptidoglycan specific muramidase (Dasgupta, *et al.*, 2003).

FlgJ was found to have N-acetyl β -D glucosaminidase activity in *Salmonella* species and it is likely that this enzyme may have a similar function in *P. aeruginosa* (Figure 4.2). The overall goal of this research project is to investigate the role of *flgJ* in *P. aeruginosa*. Specifically, its role in antibiotic resistance will be ascertained. In addition, the enzyme activity of FlgJ will also be discerned through enzyme assays. Besides its putative role in cell-wall recycling and antibiotic resistance, as this gene is a part of flagellar biosynthesis assembly, its role in motility and motility- associated phenotypes will also be investigated.

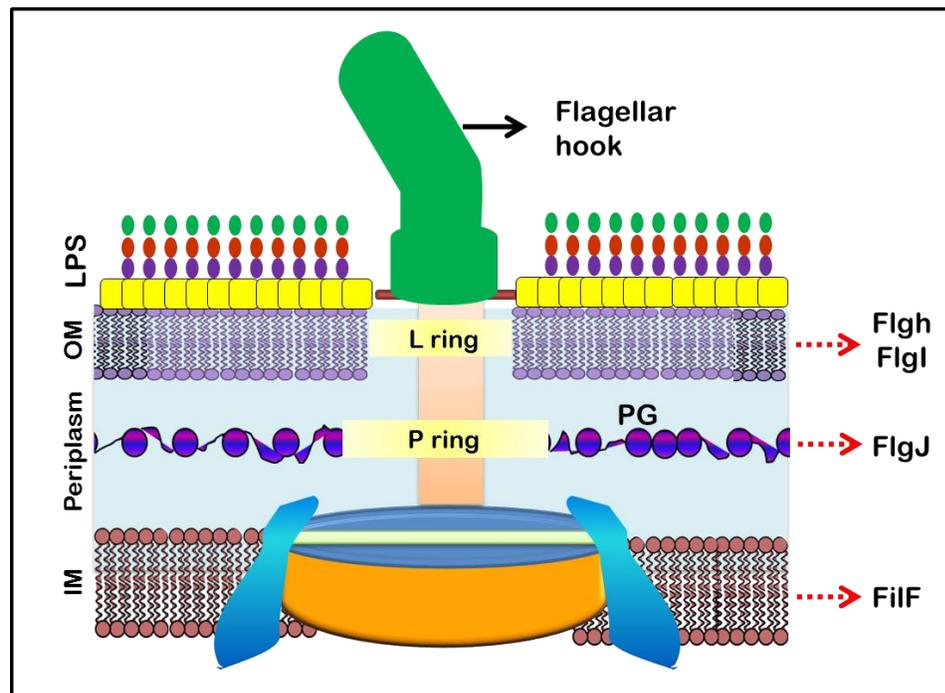

Figure 4. 2. Flagellar assembly. The model for flagellar assembly is best studied in *Salmonella* sp. The flagellum has to cross through three main barriers, the inner membrane, the peptidoglycan layer and the outer membrane to reach the host/extracellular milieu. This transport process is facilitated by the flagellar transport system (Aizawa, 1996). The transport of the flagellar rod through the inner membrane is achieved by creating gaps by the activity of FliF (Ueno, *et al.*, 1992). FlgJ creates holes in the PG layer allowing its export through the periplasmic space and through the peptidoglycan (PG) layer. PG fragments are produced at this point which may enter the PG recycling pathway and may also act as AmpR effectors. FlgH and FlgI allow the penetration of the flagellar rod through the outer membrane (Vogler, *et al.*, 1991). Land P rings are usually formed at the intersection of the flagellar rod with the outer membrane and PG, respectively (Jones, *et al.*, 1989, Nambu, *et al.*, 1999).

4.3. Materials and Methods

4.3.1 Strains, media and growth conditions. *Pseudomonas aeruginosa* PAO1 (Stover, *et al.*, 2000) and its derivatives (*PAOΔflgJ*) and *Escherichia coli* DH5α were used in this study. For triparental mating experiments, Pseudomonas Isolation Agar (Difco, NJ, USA) was used along with LB (1:1) for *P. aeruginosa* selection. For plasmid selection and maintenance, antibiotics at the following concentrations were used: Gentamicin (Gm) 15 µg/mL for *E. coli*, 75 µg/mL for *P. aeruginosa*, Carbenicillin (Cb) at 50 µg/mL for *E. coli*, 150 µg/mL for *P. aeruginosa*, Chloramphenicol (Cm) and Kanamycin (Km) at 20 µg/mL for *E. coli*.

Table 4. 2. Strains, plasmids and primers used in this study.

Strains	Relevant phenotype and genotype	Reference/ Source
<i>Escherichia coli</i>		
DH5α	F- Φ80 <i>lacZΔM15 Δ(lacZYA argF)U169 deoR recA1 endA1 hsdR17 (rk-mk+) phoA supE44 λ⁻ thi-1 gyrA96 relA1</i>	New England Biolabs
<i>Pseudomonas aeruginosa</i>		
PAO1	Wild-type	(Holloway, <i>et al.</i> , 1979)

PAO Δ <i>flgJ</i>	PAO1 containing in-frame deletion of <i>flgJ</i>	This study
PAO1(pET 15bvp)	PAO1 containing plasmid pET15BVP	This study
PAO Δ <i>flgJ</i> (pFlgJ)	PAO Δ <i>flgJ</i> containing <i>flgJ</i> on plasmid pET15BVP	This study
Plasmids		
pGEMT	TA cloning vector for PCR products; Ap ^R , ColE1 f1 ori lacZ α	Promega
pRK600	Cm ^R ; colE1 tra ⁺ RK2 mob ⁺ ; Helper plasmid for conjugation	(Figurski & Helinski, 1979)
pRK2013	Km ^R ; colE1 tra ⁺ RK2 mob ⁺ ; Helper plasmid for conjugation	(Finan, <i>et al.</i> , 1986)
pEXG2	GmR; pMB1 ori <i>sacB</i>	(Rietsch, <i>et al.</i> , 2005)
pET15bVP	ApR; pBR322 origin, <i>oriV</i> , expression vector, T7 promoter, His tag coding sequence	(Arora, <i>et al.</i> , 1997)
pSD194	Ap ^R ; A ~1.2-kb XhoI-BamHI fragment containing <i>flgJ</i> ORF (PA1085) amplified from PAO1 genome using PA1085_fw_Xho1 and PA1085_Rev_BamH1 primers and cloned into pGEMT	This study
pSD197	Gm ^R ; The <i>flgJ</i> ORF sub-cloned from pSD194 as an XhoI-BamHI fragment into pET15BVP	This study
Primers		
Gibson_flgJ_Fw	5'- tgggctagcgaattcgagctAGGAGATATACCATGG ATTCCCGTTTGCTCAGC -3'	This study
SD_PA1085_UR	5'- CGGACATGGGTCAGTTCCTCCTTGCTAGC TAGCTAGGCGTCGTCCTCAAATCACG-3	This study
SD_PA1085_DF	5'- CGTGATTTGAGGACGACGCCTAGCTAGCT AGCAAGGAGGAAGTACCCATGTCCG-3'	This study
Gibson_flgJ_Rev	5'- ggatccccgggtaccgagctTCAACCCAGAGGCGG CGT -3'	This study
PA1085_fw_Xho1	5'- ACACTCGAGAGGAGATATACCATGGATTC CCGTTTGC-3'	This study
PA1085_Rev_BamH1	5'-GGATCCTCAACCCAGAGGCGGCG-3'	This study

4.3.2 Construction of *flgJ* deletion mutants by homologous recombination using

Gibson cloning. A deletion strain of *flgJ* (PA1085) was constructed using a Gibson

cloning kit (Gibson, *et al.*, 2009). The DNA sequences upstream (P1) and downstream (P2) of the gene to be deleted were amplified by PCR using High-fidelity polymerase (*Pfu* DNA Polymerase, Promega, Madison, WI) and primer pairs Gibson_flgJ_Fw, SD_PA1085_UR and SD_PA1085_DF, Gibson_flgJ_Rev (primers listed in table 4.2). The amplicons generated were fused with the *EcoR1*-linearized plasmid pEXG2 to regenerate the recombinant plasmid (Hoang, *et al.*, 1998). The amplicons were sequenced to ensure fidelity. Henceforth, a similar protocol as used for deletions by yeast-method was followed. The recombinant plasmid was conjugated into *P. aeruginosa* PAO1 by tri-parental mating for homologous recombination with PAO1 genome (Figurski & Helinski, 1979, Finan, *et al.*, 1986). The colonies that showed integration of the deletion product, as well as the presence of the target gene, also known as single-crossovers, were selected for generating double-crossovers. The double-crossovers were identified by screening for their gentamycin sensitivity and sucrose resistance. The deletion product was verified by PCR amplification and sequencing. Henceforth, this strain is referred to as PAO Δ *flgJ*.

4.3.3 Construction of *flgJ* complementing clones. The *flgJ* (~1.2 kb) gene was PCR amplified using primer pairs PA1085_fw_Xho1 and PA1085_Rev_BamH1 (Table 4.2) from *P. aeruginosa* PAO1 genome. The PCR-amplified product was cloned into pGEMT (Promega, Madison, WI). The fidelity of the PCR-amplified product was confirmed by sequencing. The insert carrying *flgJ* was then moved into a broad-host range pET15bVP plasmid as *Xho1-BamH1* fragment, henceforth known as pFlgJ (Arora, *et al.*, 1997). These plasmids were introduced by triparental mating into PAO Δ *flgJ*.

4.3.4 Minimum-inhibitory concentration (MIC). The MIC was determined using the E-test (BioMerieux), which is extensively viewed as a reliable method of susceptibility analyses (Jorgensen, 1993, Amsler, *et al.*, 2010). Briefly, overnight cultures of bacteria were diluted to an O.D. of 0.02-0.2 and spread on a Mueller-Hinton-agar plate. Following this, an E-test containing antibiotics at an increasing concentration along the length of the strip was placed on the plate. The MIC was determined by the zone of clearance on the plate after 16-18 hr incubation at 37 °C.

4.3.5 Motility assays. Swimming assays were done by stabbing 0.3% LB agar plates with a single colony of PAO1, PAO Δ *flgJ*, PAO1(pET15bVP), and PAO Δ *flgJ*(pFlgJ) bacteria (Henrichsen, 1972). Swarming plates made of 0.5% LB agar were inoculated with a single colony of the above-mentioned strains and incubated at 30°C overnight (Allison & Hughes, 1991). The swimming and swarming zone were measured after overnight incubation at 30 °C.

4.3.6 Biofilm assay. Biofilm assay was performed in tubes as described previously (Friedman & Kolter, 2004). Briefly, overnight cultures of PAO1 and mutant strains were grown on LB agar plates were resuspended in LB and diluted to final OD of 0.0025. PAO Δ *retS* and PAO Δ *algD* Δ *pel* Δ *psl* were kept as positive and negative controls, respectively. All the tubes were incubated at 37 °C for 24 hours. Subsequently, the culture was discarded, and the tubes washed in bins containing water and left at room temperature for ten minutes. This was stained with 0.1% crystal violet. The dye was removed after 20 minutes and the tubes were washed thoroughly with running tap-water. The attached dye was then solubilized with absolute ethanol and biofilm formation was quantified by recording the absorbance at 590nm.

4.3.7 N-acetylglucosaminidase assay. This assay was performed as stated previously (Asgarali, *et al.*, 2009). Briefly, the whole cell and periplasmic fractions from bacteria at late-log phase were extracted. To the sample buffer containing 1xPBS, the substrate 4-methylumbelliferyl N-acetyl β -D-glucosaminide (4-MUGlcNAc) was diluted to a final concentration of 2 mM. Extracts containing 20 μ g of protein was added to a 100 μ l PBS with substrate. This was incubated at 37 $^{\circ}$ C for 4 and 8 hrs. At the end of each time-point the reaction was quenched by adding 900 μ l of 0.1 M glycine-NaOH (pH-10.5). The fluorescence was measured by using an excitation wavelength of 360 nm and monitoring the emission wavelength of 450 nm on a Synergy H1 Hybrid Reader (Biotek, Winooski, VT). The assay was carried out in triplicates on black 96 well-plates with optical bottom (Thermo Fisher). Controls contained wells with PBS and substrate (2 mM of 4-MUGlcNAc), and PBS alone. As a control, PAO Δ *nagZ* was used which has a deletion of the gene encoding the cytoplasmic N-acetylglucosaminidase NagZ/PA3005. The results were quantified by measuring the fluorescence against our experimental time-points.

4.4. Results

4.4.1 *flgJ* is required for swimming motility. Motility is one of the primary virulence factors of *P. aeruginosa*. *P. aeruginosa* shows three main types of motilities which include swimming, swarming and twitching (Henrichsen, 1972). Swimming occurs on a relatively more liquid surface as compared to swarming (0.3% agar vs 0.6% agar). Swimming is mainly a flagella-regulated movement whereas swarming is regulated partially by flagella and pili (Henrichsen, 1972, Rashid & Kornberg, 2000). It was found that deletion of *flgJ* led to a deficiency in swimming motility when compared to the wild-

type PAO1, whereas swarming motility was unaffected. This may be since swarming movements are the result of the polar flagellum usually found in *P. aeruginosa*, as well as pili and additional alternative motors (Doyle, *et al.*, 2004, Toutain, *et al.*, 2005).

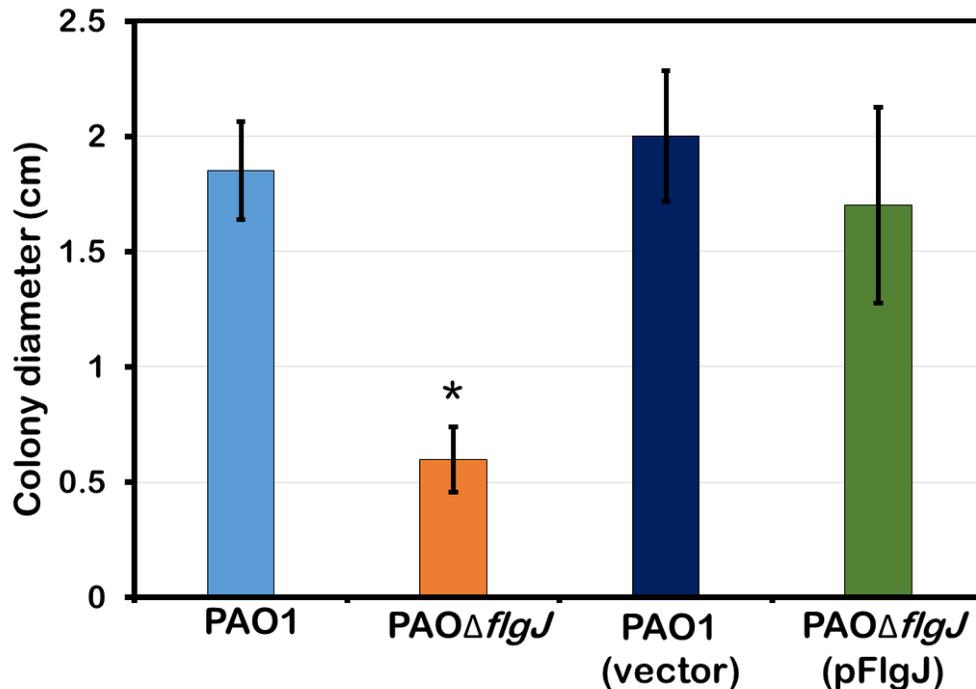

Figure 4. 3. Swimming motility of PAOΔflgJ vs PAO1. FigJ was found to be required for regulating swimming motility in PAO1. Values were significant at $p < 0.05$ (PAOΔflgJ vs PAO1 $p=0.02$, as determined by unpaired student's T-test)

4.4.2 flgJ is required for initiation of biofilm. The formation of biofilms was measured by growing the culture in polystyrene tubes over 24 and 48 hours. Biofilm is an aggregate of polysaccharides, mainly Pel and Psl, extracellular DNA and water channels formed as an extracellular matrix by *P. aeruginosa* (Branda, *et al.*, 2005, Ryder, *et al.*, 2007). An important consequence of this feature is the increased resistance of the bacteria to antibiotics (Stewart, 2002). A biofilm is formed when the bacteria adhere firmly to an abiotic or biotic surface and clinically, is associated with chronic infection

phenotypes. Quantitation was done by staining the biofilm formed at the air-liquid interphase with 0.1% crystal violet. PAO Δ *retS* was used as the positive control as *retS* is involved in inhibition of GacA phosphorylation which promotes biofilm (Goodman, *et al.*, 2009). PAO Δ *pel* Δ *psl* Δ *algD*, a biofilm non-former was used as the negative control for this assay (Balasubramanian, *et al.*, 2012). It was found that in initial stages at 24 hours, where the bacteria attach to the surface, *flgJ* deletion strains were lagging slightly as compared to the wild-type PAO1, whereas over a time-period of 48 hours, this was negated. In fact, absence of flagella seemed to contribute to higher levels of biofilm formation. This data concurs with previous studies which demonstrate that the flagellum is required only at the initial stages of biofilms.

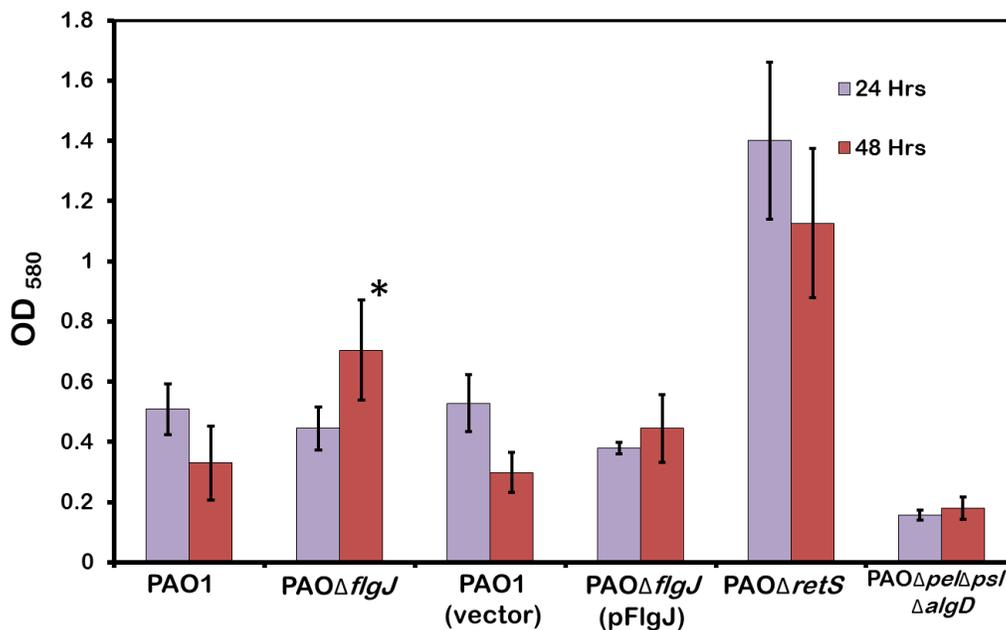

Figure 4. 4. Biofilm formation assay. Biofilms were measured over 24 and 48 hour time-period for all the strains. Differences between the parent PAO1 and deletion was found to be significant at 48 hours (* *p* value = 0.03 as determined by unpaired T-test)

4.4.3 MIC of selected antibiotics is unaltered in absence of *flgJ*. To investigate the role of *flgJ* in *P. aeruginosa*, a precise deletion of the gene was constructed in the wild-

type reference strain, PAO1. The β -lactam susceptibility of this strain was investigated using the E-test. The antibiotics chosen were based on our hypothesis that FlgJ hydrolyzes the peptidoglycan and generate the monosaccharide mucopeptides namely the 1, 6 anhydro peptides which have been shown to act as effectors of AmpR. Hence β -lactams and other antibiotics which show differential expression in absence of AmpR were investigated (Balasubramanian, *et al.*, 2012). However, no difference was noted in the mutant strain PAO Δ flgJ in comparison to the parent strain PAO1.

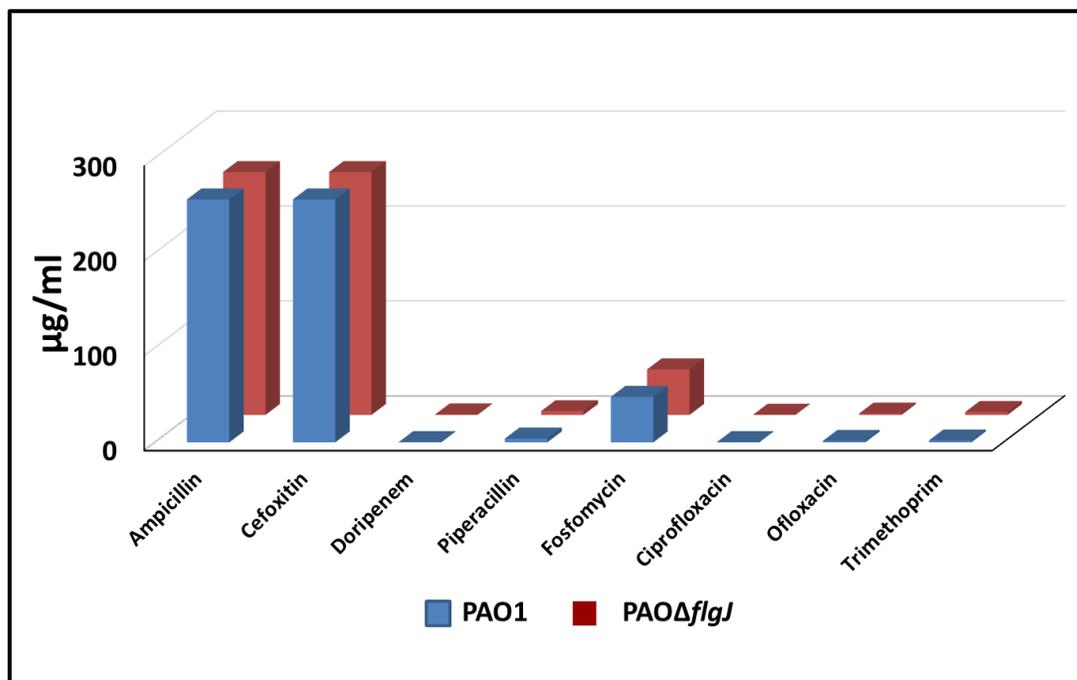

Figure 4. 5. MIC of mutant strains PAO Δ flgJ. The MIC of β -lactams and other antibiotic that exhibit a differential difference with AmpR deletion was investigated in PAO Δ flgJ and compared to the parent strain PAO1. No significant difference is found between the groups as determined with T-test.

4.4 N-acetylglucosaminidase assay. This assay is based on the conjugation of a fluorogenic substrate, 4- methyl umbelliferyl attached to N-acetyl β -D glucosaminide (4MU GlcNAc). This assay has been used previously to detect N-acetylglucosaminidase

activity from lysates of *P. aeruginosa* to determine NagZ expression (Asgharali, *et al.*, 2009). NagZ (PA3005) is currently the only known enzyme in *P. aeruginosa* to possess *N*-acetylglucosaminidase activity. *P. aeruginosa* strains that do not have this gene, hence, have decreased fluorescence in the presence of 4-MUGlcNAc (as was confirmed in this assay). The fluorescence emitted due to the fission of 4-MUGlcNAc from the different bacterial whole-cell extracts were quantified after normalizing with the fluorescence detected from PAO Δ nagZ. Wells were kept with just the substrate in buffer and the fluorescence recorded from these wells was subtracted from all the test sample wells. When compared with the wild-type PAO1, no significant difference in fluorescence was found in PAO Δ flgJ. As flgJ is believed to be periplasmic, the cleavage of 4-MUGlcNAc will be compared between periplasmic fractions of PAO1 and PAO Δ flgJ.

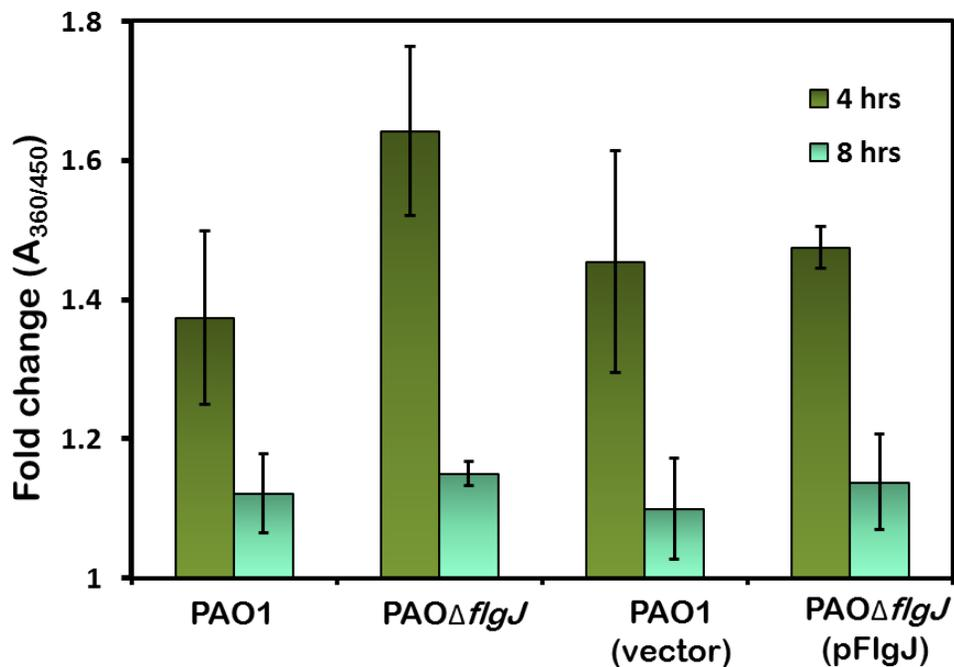

Figure 4. 6. N-acetylglucosaminidase activity in whole-cell extracts. The activity of N-acetylglucosaminidase in whole cell extracts were measured using 4-Methylumbelliferyl N-acetyl- β -D-glucosaminide as a substrate. Fluorescence was measured using an excitation wavelength of 360nm and emission at 450nm. Values were normalized to that of *nagZ* deletion strain. No significant difference in fluorescence was observed in PAO1 and PAO Δ *flgJ* whole-cell lysates ($p > 0.05$, as determined by unpaired students T-test).

4.5 Discussion

Cell-wall recycling is closely related to β -lactam resistance. A particular focus of our lab was to elucidate the profile of muropeptides generated during cell wall recycling in *P. aeruginosa* (Lee, *et al.*, 2016). In our studies, elevated levels of two periplasmic muropeptides GlcNAc anhydroMurNAc- and 1, 6 anhydroMurNAc pentapeptides were detected in the presence of β -lactams which were later confirmed as the AmpR effector (Dik, *et al.*, 2017). Previous to our *in vivo* analysis of *P. aeruginosa* muropeptides, 1, 6 anhydroMurNAc were known to be generated exclusively in the cytoplasm following the activity of a N-acetyl β -glucosaminidase NagZ (PA3005) (Asgarali, *et al.*, 2009). NagZ is established as an antibiotic target and small-molecule inhibitors of NagZ have been synthesized which attenuate β -lactamase expression and impair β -lactam resistance (Stubbs, *et al.*, 2007, Yamaguchi, *et al.*, 2012).

During our analysis of muropeptides in *P. aeruginosa*, we detected 1, 6 anhydroMurNAc peptides in the periplasm suggesting the existence of a novel periplasmic β -N-acetylglucosaminidase. A periplasmic N-acetylglucosaminidase FlgJ was identified in *S. enterica* which led us to analyze *P. aeruginosa* FlgJ/PA1085 (Herlihey, *et al.*, 2014). In *P. aeruginosa* *flgJ* (PA1085) is a part of the flagellar assembly operon and its role has been associated with flagellar biogenesis. The synthesis of

flagellar units occurs in the cytoplasm and its assembly and transport is facilitated by the activity of the flagellar transport system (Iino, 1974). For the flagella to reach the extracellular milieu, three barriers, namely the inner membrane, PG layer and the outer membrane have to be traversed. It has been presumed that the peptidoglycan layer is broken down by hydrolases that are present in the periplasmic space to facilitate the flagellar insertion (Fein, 1979). The assembly and transport of the flagella have so far not been studied in *P. aeruginosa*. FlgJ in *Salmonella* was the first account of an *N*-acetylglucosaminidase in the periplasm that breaks the PG allowing the insertion of the flagella and in this process generates monosaccharides (Herlihey, *et al.*, 2014). To understand the role of FlgJ, a precise in-frame deletion was constructed using Gibson cloning. This technique of deletion was adapted as it yields results in a much shorter time than that we previously used involving yeast-system based recombination (Kalva, *et al.*, 2018).

Absence of *flgJ* resulted in diminished swimming motility and increased biofilm formation which was restored by *in trans* complementation to the level of wild-type. Motility and chemotaxis are one of the main virulence factors that help in establishing infections in the host. Absence of FlgJ however did not show any difference in the susceptibility profile of selected antibiotics. This would suggest to us that FlgJ is not involved in antibiotic resistance. However, an interesting analysis will be to over-express this protein and observe its effects on the MIC levels. Levels of *N*-acetylglucosaminidase were determined in PAO Δ *flgJ* and compared to that of PAO1 using 4-MUGlcNAc as the substrate for *N*-acetylglucosaminidase. PAO Δ *nagZ* was used as a control and it was found that there was no difference in the levels between the *flgJ* deletion and the wild-type whole-cell extract. For further analysis the periplasmic extracts will be analyzed for the enzyme activity.

In Gram-positive organism such as *Enterococcus faecalis* one of the primary *N*-acetylglucosaminidases is AtIA (Eckert, *et al.*, 2006). This enzyme comprises of three domains, with a threonine/glutamate rich N-terminal, a catalytic central domain and LysM domains at the C-terminal, each of which is required for the maximal hydrolytic activity of the peptidoglycan (Eckert, *et al.*, 2006). Upon comparisons of the protein domains, we find that PA1085 has a similar conserved LysM domain. The LysM domain is indicative of proteins that are capable of binding with the PG and is hence important for eliciting the full enzymatic activity of the protein (Buist, *et al.*, 2008). The conservation of this sequence in FlgJ further reinforces our hypothesis that this enzyme may have an *N*-acetylglucosaminidase activity. Domain analysis of PA1085 using the Carbohydrate - active enzymes (CAZy) database also reveals that it belongs to the glycoside hydrolase family of proteins GH73 (Cantarel, *et al.*, 2009). Proteins belonging to this family are known to cleave the linkage between N-GlcNAc and MurNAc (Hashimoto, *et al.*, 2009).

Besides FlgJ, genome analysis of *P. aeruginosa* revealed a second periplasmic glucosidase BglX (PA1726) which is yet to be characterized. Upon multiple sequence alignment of NagZ, FlgJ and BglX, it was found that one of the active site residues of NagZ, D244, are conserved on both FlgJ and BglX. This suggests the possibility of a different periplasmic hydrolase that may generate the periplasmic monosaccharides. Our research has explored the role of AmpP/PA4218 as an exporter of disaccharide-peptides. Alternatively, there may be another transporter which exports the cytoplasmic monosaccharides into the periplasm.

4.6 Acknowledgements

We would like to thank Dr. Brian Mark (University of Manitoba) for providing us with the *nagZ* strains. This study was funded in part by NIH/NIGMS R25 GM061347 to Supurna Dhar (SD) and Florida International University Dissertation Year Fellowship (SD).

Chapter 5

Small-Molecule Library Screening For *Pseudomonas aeruginosa* AmpR Inhibitors

5.1. Abstract

Pseudomonas aeruginosa has been classified by the World Health Organization as a pathogen of “critical” importance. It causes serious acute and chronic infections often resulting in life-threatening episodes. Previous research in our lab has identified players in the *amp* system which plays a role in antibiotic resistance and virulence. AmpR has an extensive regulon in *P. aeruginosa* and is intricately linked to antibiotic resistance, recycling of the cell-wall and expression of virulence factors required for infection. Although AmpR has been identified in many pathogens, its role in *P. aeruginosa* appears to be more elaborate. In *P. aeruginosa*, AmpR has been shown to localize in the membrane and exist as a dimer in the active form which is further explained in this research through structural modelling. This research also explores AmpR as a novel antibiotic target. A phenotypic screening assay has been developed fusing promoters regulated by AmpR, P_{ampC}, to a lux operon cassette. This reporter was used to screen scaffold-based combinatorial library for AmpR inhibitors. Positive hits identified from this study will be further counter-screened using reporters with alternate AmpR regulated promoters namely, P_{phzA1} and P_{mexE}. Novel compounds that are identified in this study can also be used for other pathogen with a homologous AmpR-AmpC system such as *Yersinia enterocolitica*, *Burkholderia cenocepacia*, and *Stenotrophomonas maltophilia*.

5. 2. Introduction

Pseudomonas aeruginosa is known for causing recalcitrant infections in mainly immunocompromised patients and at least 10% of all nosocomial infections in the US are due to this pathogen (Bodey, *et al.*, 1983, Gaynes & Edwards, 2005). This

opportunistic bacterium can cause a wide-range including both chronic and acute infections in humans (Furukawa, *et al.*, 2006). Some of the chronic infections are respiratory tract and lung-associated resulting in chronic pneumonia, pan bronchiolitis, and chronic obstructive pulmonary disorder (Rose, 1968, K. Yanagihara 2001, Boyer, *et al.*, 2005, Martinez-Solano, *et al.*, 2008). One of the most archetypal chronic infections linked with this pathogen is found in cystic fibrosis (CF) patients. CF lungs present with mixed-infections, colonized by *P. aeruginosa*, *Staphylococcus aureus*, *Haemophilus influenzae*, Methicillin-resistant *S. aureus* (Marks, 1990, Rayner, *et al.*, 1990, Koch & Hoiby, 1993, Tummler, *et al.*, 1997, Miall, *et al.*, 2001, Marshall, *et al.*, 2016). Owing to its incredible multi-factorial pathogenesis and propensity for antibiotic resistance, with an increase in the patient's age, *P. aeruginosa* reigns supreme amongst the other lung-associated infections (West, *et al.*, 2002). These recurrent pulmonary infections result in increased inflammatory responses and lung deterioration, ultimately causing high morbidity and mortality (Yum, *et al.*, 2014, Langan, *et al.*, 2015). Besides chronic, *P. aeruginosa* also possess the virulence arsenal for acute infections (Yahr & Greenberg, 2004). Notable ones include acute pneumonia, particularly in patients who are hospitalized or are unable to mount a sufficient immune response against *P. aeruginosa* (Pereira, *et al.*, 2014). Other significant ones include acute keratitis occurring in up to 40% of cases found in US. Besides these, sepsis due to bacteremia and wound-infections due to burns or post-surgery and urinary tract infections are also observed (Wu, *et al.*, 1999, Estahbanati, *et al.*, 2002, Kang, *et al.*, 2003, Secher, *et al.*, 2005, Shigemura, *et al.*, 2006, Miyayama, *et al.*, 2016).

Underlying these two infection phenotypes are distinct groups of virulence factor and their regulators (Furukawa, *et al.*, 2006, Gellatly & Hancock, 2013). The prominent ones that contribute to chronic infection include biofilm and alginate, often found in a CF lung

(Pedersen, *et al.*, 1990, Pedersen, 1992, Winstanley, *et al.*, 2016). Acute infection is due to release of exo- and endo-toxins, proteases and involves largely the quorum sensing (QS) and type 3 secretion systems (T3SS) (Smith & Iglewski, 2003, Hauser, 2009). The decision of an acute or chronic infection in the host is regulated by the environmental signals which determine the gene expression levels of various virulence determinants. Often, the inability to cure an acute infection results in genetic adaptive changes in the organism resulting in a chronic infection (Furukawa, *et al.*, 2006, Balasubramanian, *et al.*, 2013, Winstanley, *et al.*, 2016). Thus, preventing the establishment of an acute infection is of fundamental importance.

Previous studies in our lab have shown that a transcriptional factor involved in regulating acute infection phenotypes is AmpR (PA4109) (Balasubramanian, *et al.*, 2015). AmpR has been the focus of research for long as it was recognized that it is a pivotal point for regulating β -lactamase resistance (Normark & Lindberg, 1985, Wiedemann, *et al.*, 1998). In addition to its role as a cynosure in β -lactam resistance, in *P. aeruginosa* it also acts as a “global” regulator (Balasubramanian, *et al.*, 2012). The extent of its regulation is limited to not just β -lactams, but towards many non- β -lactam antibiotics as well as acute infections- related phenotypes. One of the major areas where AmpR influence is seen is toward the quorum sensing (QS) regulated phenotypes, including production of LasA, LasB proteases, phenazine pigments as well as in biofilm formation (Balasubramanian, *et al.*, 2012). It has been found that AmpR regulates three of the four QS in *P. aeruginosa*; Las, Rhl, and PQS (Balasubramanian, *et al.*, 2014). These systems together improvise a majority of virulence factors affecting acute infections. AmpR deletion also favors diminished virulence of *P. aeruginosa* in animal models of toxicity (Balasubramanian, *et al.*, 2012). In addition to virulence factors, AmpR is also required for essential metabolic processes that promote survival in the

host, such as iron uptake and response to oxidative-stress (Balasubramanian, *et al.*, 2012, Balasubramanian, *et al.*, 2014).

Besides regulating multiple virulence and other metabolic processes, *P. aeruginosa* AmpR along with other players of cell-wall recycling also plays a central role in regulating β -lactam resistance (Kong, *et al.*, 2005). Furthermore, its influence is not limited to just β -lactams but to other antibiotics such as fluoroquinolones and aminoglycosides (Balasubramanian, *et al.*, 2012). Previous research in our lab has also shown that AmpR creates cross-resistance between antibiotics in the presence of sub-inhibitory concentrations of β -lactam antibiotics (Kumari, *et al.*, 2014).

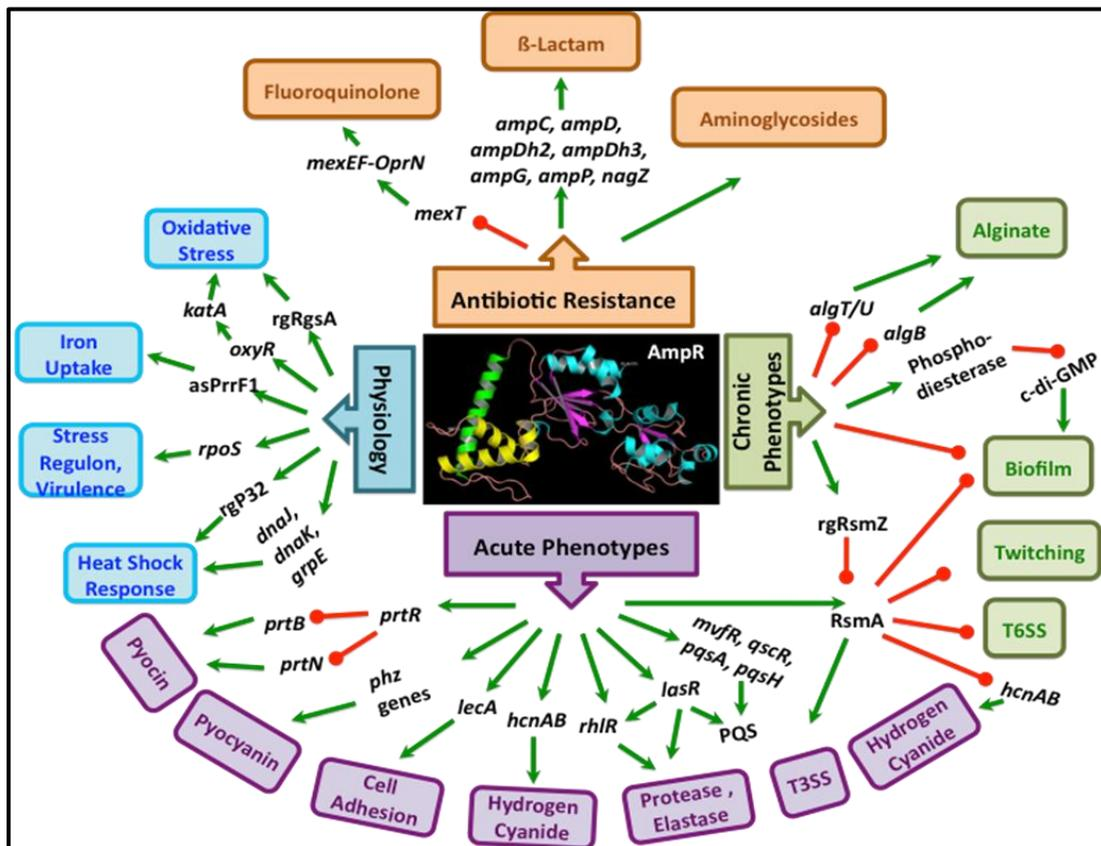

Figure 5. 1. AmpR regulon. AmpR which was previously known to be connected to β -lactam resistance was shown to have an extensive regulon in *P. aeruginosa*. Reprinted with permission from Oxford Publishing.

The increasing evidence that AmpR plays a massive role in the pathogenicity of *P. aeruginosa* supports it as a candidate for a novel antibacterial target. The benefits of inhibiting AmpR are multi-fold. The rising antibiotic resistance demands that we look into identifying not just novel small-molecules that can be used as drugs but also develop novel antibacterial targets. The targets that depart from showing lethality towards the bacteria are preferred as that would not evoke rapid evolutionary protective responses from the bacteria (Kaczor, *et al.*, 2017). Rather, any target that deprives the organism of its virulence arsenal and promotes a synergistic effect with other antibiotic targets is preferred (Lynch & Wiener-Kronish, 2008, Silver, 2011). In addition, the AmpR-AmpC system is found in many pathogens such as *Yersinia enterocolitica*, *Stenotrophomonas maltophilia*, *Burkholderia cenocepacia* (Seoane, *et al.*, 1992, Proenca, *et al.*, 1993, Okazaki & Avison, 2008). Furthermore, this protein does not have its homolog in humans hence makes it unique to bacteria.

This part of my dissertation project deals with further exploring AmpR and its relevance in *P. aeruginosa*. Firstly, the localization of AmpR in membrane is reiterated again, this time using both sucrose-gradient studies. In addition, we also describe a reporter screen constructed for evaluation of small-molecule inhibitors of AmpR. Furthermore, it has been shown that our reporter system can be used to detect for QS inhibitors.

5.3. Materials and Methods

5.3.1. Strains, media and growth conditions. *P. aeruginosa* PAO1 (Stover, *et al.*, 2000) and its derivatives (*PAOΔampR*) and *Escherichia coli* DH5α were used in this study. For triparental mating experiments, Pseudomonas Isolation Agar (Difco, NJ, USA) was used along with LB for *P. aeruginosa* selection. For plasmid selection and maintenance, antibiotics at the following concentrations were used: Tetracycline (Tet) 20 μg/mL for *E. coli*, 100 μg/mL for *P. aeruginosa*, Carbenicillin (Cb) at 50 μg/mL for *E. coli*, Chloramphenicol (Cm) and Kanamycin (Km) at 20 μg/mL for *E. coli* and at 50 μg/mL for *P. aeruginosa*.

5.3.2. Membrane fractionation. Membrane fractions were isolated using previously established protocols. *PAOΔampR* and *PAOΔampR* (pAmpR-His6) cells were streaked on LB-agar. A single colony was inoculated next day in LB with and without antibiotics and grown until an OD₆₀₀ of 0.2. *PAOΔampR* (pAmpR-His6) was induced with 1Mm IPTG and incubated for 6 h with shaking before harvesting. Cells were recovered by centrifugation at 5,000x g for 15 min at 4°C and washed with equal volume of 20mM of Tris-Cl. The culture was then resuspended in lysis buffer containing 20mM Tris-cl, pH 8, 0.1M NaCl, 1mM EDTA, 100 μg of DNase I, 1mg/ml Lysozyme and 1X Roche complete protease inhibitor cocktail. Following disruption of the cells on ice with sonication (15 cycles of 10-s pulse on and 30-s pulse off; amplitude, 40%), the cell lysate was centrifuged at 4,000 x g for 10 min at 4°C to remove unbroken cells. The supernatant was ultra-centrifuged at 36,000 rpm (Beckman Coulter Ti45 rotor) for 3 h at 4°C, and the pellets containing membrane were resuspended in membrane buffer containing 25% sucrose, 20 mM Tris, pH 7.4, and 1X Roche complete protease inhibitor cocktail. The membrane fractions were aliquoted and stored at -80°C. All Western blots were

developed according to previous protocols. Briefly, equal amounts of proteins were loaded on a 12% SDS-PAGE gel and run at 100 Volt for 1 h. The proteins were then transferred to a polyvinylidene difluoride (PVDF) membrane (Bio-Rad) and blocked with 3% BSA in Tris-buffered saline (TBS) at 4°C overnight or at room temperature for 1 h. The membrane was washed after blocking with TBST three times for ten minutes each and probed with mouse-anti-His antibody (Biolegend, 1: 3,000) for 2 h at room temperature or at 4 °C overnight. Membranes were subsequently washed with TBST, incubated with anti-mouse IgG horseradish peroxidase-conjugated antibody (1: 5,000) (Bio-Rad) for 1.5 h. The membranes were washed with TBST and developed using SuperSignal West Pico Chemiluminescent Substrate (Pierce). The membrane fraction was confirmed using Lactate dehydrogenase enzyme activity assay.

5.3.3. Modeling of AmpR. The monomer structure of AmpR effector binding domain from *Citrobacter freundii* was obtained from protein data bank (pdb ID 3KOS.pdb). The python script MakeMultimer.py was used to construct the dimer structure from BIOMT transformation matrices contained in the pdb file. The visual molecular dynamics (VMD) software was used to visualize and mutate structure (Humphrey, *et al.*, 1996).

5.3.4. Reporter construction for luciferase assays. Reporters were constructed with fusion of AmpR regulated promoters upstream of the *lux* operon. Specifically, P_{ampC} and P_{phzA} , which are respectively regulated by AmpR, with and without induction, were selected (Balasubramanian, *et al.*, 2012). P_{ampC} (~ 100 bp) was amplified from *P. aeruginosa* PAO1 genome using primers EL04_ampC_forward_Xho and EL05_ampC_reverse_BamH1 and cloned into pGEMT vector (PROMEGA). This was

ligated into kanamycin resistant pMS402 plasmid (11.8Kb) upstream of a promoterless *luxCDABE* operon (Olsen, *et al.*, 1982, Duan, *et al.*, 2003). The operon encodes for all the synthase as well as the substrate for luciferase. This plasmid pMS402 (P_{ampC}) is henceforth known as pHK478. This plasmid was further digested with Pac1 restriction enzymes to yield an 8 Kb product that was ligated with Pac 1 digested pCDS101 plasmid containing the CTX backbone including sequences required for integration of plasmid into the *Pseudomonas* genome. This ligation product is electroporated in to Lucigen Electro-competent cells and plated on tetracycline and kanamycin. Resulting clones were analyzed by PCR and sequenced. Colonies containing the resulting plasmid with P_{ampC} is henceforth referred to as HK502. HK502 is then mated into *P. aeruginosa* PAO1 to yield PAOattB::PampC-*lux*, henceforth known as HK504. *ampC* is regulated by AmpR specifically in the presence of an inducer such as imipenem. A second reporter strain is constructed with P_{phzA} which is regulated by AmpR without any inducer. Plasmid pCDS101 contained the P_{phzA} with *luxCDABE operon* and was introduced into *P. aeruginosa* PAO1 and PAO $\Delta ampR$ by triparental mating. The final clones are PAOattB:: P_{phzA} -*lux* and PAO $\Delta ampR$ attB:: P_{phzA} -*lux* and are known as SD98 and SD94, respectively. The strains were validated by PCR amplification, sequencing and by phenotypic assay for luciferase activity.

Table 5. 1. Strains, plasmids and primers used in this study.

Strains	Relevant phenotype and genotype	Reference/ Source
<i>Escherichia coli</i>		
DH5 α	F- Φ 80 <i>lacZ</i> Δ M15 Δ (<i>lacZYA argF</i>)U169 <i>deoR recA1 endA1 hsdR17</i> (rk-mk+) <i>phoA supE44</i> λ^- - <i>thi-1 gyrA96 relA1</i>	New England Biolabs
<i>Pseudomonas aeruginosa</i>		
PAO1	Wild-type	(Holloway, <i>et</i>

		<i>al.</i> , 1979)
PAO Δ <i>ampR</i>	PAO1 containing in-frame deletion of <i>ampR</i>	
PAO Δ <i>ampR</i> (pAmpR)	PAO Δ <i>ampR</i> containing <i>ampR</i> on plasmid pMMB67-EH	
PAO <i>attB</i> ::P <i>ampC</i> - <i>lux</i>	PAO1 containing <i>P_{ampC}</i> upstream of <i>luxCDABE</i> operon	This study
PAO1 <i>attB</i> ::P <i>phzA</i> - <i>lux</i>	PAO1 containing <i>P_{phzA}</i> upstream of <i>luxCDABE</i> operon	This study
PAO Δ <i>ampRattB</i> ::P <i>phzA</i> - <i>lux</i>	PAO Δ <i>ampR</i> containing <i>P_{phzA}</i> upstream of <i>luxCDABE</i> operon	This study
Plasmids		
pGEMT	TA cloning vector for PCR products; Ap ^R , ColE1 f1 ori lacZ α	Promega
pRK600	Cm ^R ; colE1 tra ⁺ RK2 mob ⁺ ; Helper plasmid for conjugation	(Figurski & Helinski, 1979)
pRK2013	Km ^R ; colE1 tra ⁺ RK2 mob ⁺ ; Helper plasmid for conjugation	(Finan, <i>et al.</i> , 1986)
pMMB67EH-Gm	Gm ^R ; IncQ, RSF1010, lacI ^q P _{tac} expression vector with <i>ampR</i> :: <i>aacC1</i> insertion at <i>DraI</i>	(Furste, <i>et al.</i> , 1986)
pOC19	GmR; pMMB67EHGM containing 933-bp EcoRI-BamHI <i>ampR</i> -His6 fragment from pOC11	(Caille, <i>et al.</i> , 2014)
pMS402	Km ^R , Tc ^R Expression reporter plasmid carrying the promoter less <i>luxCDABE</i> ;	(Olsen, <i>et al.</i> , 1982, Duan, <i>et al.</i> , 2003)
mini-CTX <i>lux</i>	Tc ^R , <i>luxCDABE</i> based reporter vector with site specific integration at <i>attB</i> site in <i>P. aeruginosa</i> chromosome	(Becher & Schweizer, 2000)
pCDS101	Modified MINI-CTX with <i>phzA1</i> promoter directionally cloned upstream of the luciferase operon	Personal Communication with Surette lab
pHK478	<i>P_{ampC}</i> with Xho1-BamH1 sites, directionally cloned upstream of the luciferase operon in pMS402.	This study
pHK502	8KB Pac1 digest from pCDS101 containing sequence for integrase mediated recombination with PAC1 digested pHK478 containing <i>P_{ampC}</i>	This study
Primers		
EL04_ <i>ampC</i> _forward_Xho	5'-ACACTCGAGAGGAGATATACCATGGATTCCCGTTTGC-3'	This study
EL05_ <i>ampC</i> _reverse_BamH1	5'-GGATCCTCAACCCAGAGGCGGCG-3'	This study

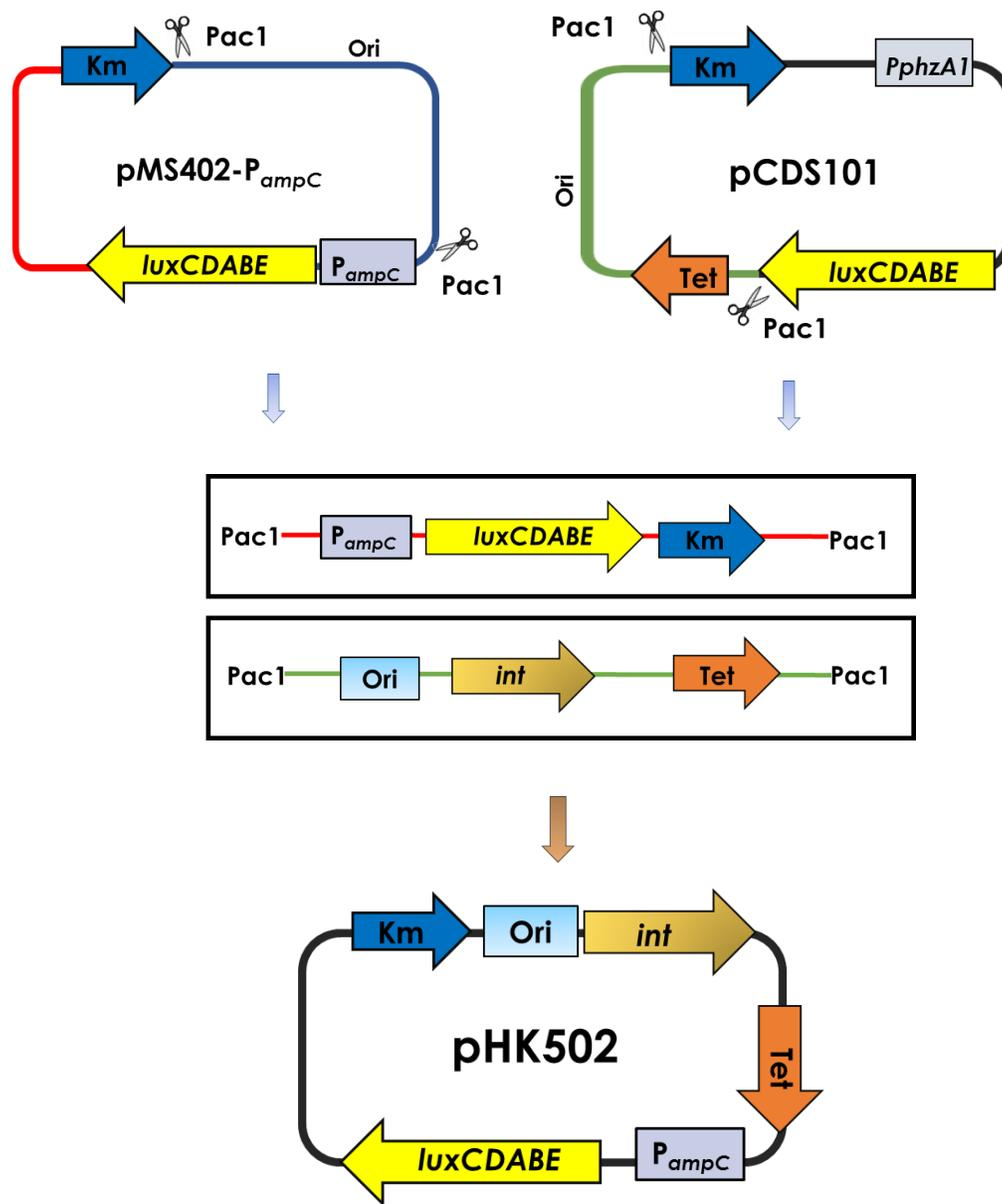

Figure 5.2. Construction of PAO1::P_{ampC}-lux. The strategy is to construct reporters that fuse promoters under direct regulation with AmpR. AmpR has been shown to bind to promoter region of AmpC. From the first plasmid pMS402, the region comprising of *ampC* promoter with the *lux* cassette and the marker for kanamycin was digested using Pac1. From the second plasmid, pCDS101- a derivative of mini-ctx lux plasmid, the region comprising of sequences required for integration in the *Pseudomonas* genome is digested with Pac1. These two fragments are ligated and electroporated into *E. coli*. The resulting plasmid contains the *ampC* promoter upstream of a promoterless Lux cassette and is integrated into *Pseudomonas* genome following triparental mating.

5.3.5. Luciferase Assay of reporter strains. The reporter strains PAO1*attB::P_{ampC}-lux*, PAO1*attB::P_{phzA}-lux* and PAOΔ*ampRattB::P_{phzA}-lux* were streaked on LB -agar plate with antibiotics. Overnight grown stocks were resuspended in fresh LB to an OD₆₀₀ of 1. The bacteria were then re-diluted to an OD₆₀₀ of 0.02 and grown in LB until OD₆₀₀ 0.2. For PAO1*attB::P_{ampC}-lux*, the culture was divided into two flasks where one was treated with sub-inhibitory concentration of imipenem (0.1µg/ml). The cultures were distributed into 96 well plates. This was then placed in the Biotek Synergy plate reader. The initial OD₆₀₀ and luminescence values was recorded in kinetic mode over three hours at which time the highest levels of luminescence were reached. The relative luminescence units (RLU) were normalized to cell number using OD₆₀₀. Z' value of the assay was compared with the values for positive and negative controls, which in the case of PAO*attB::P_{ampC}-lux* was the induced and uninduced cultures. For PAO*attB::P_{phzA}-lux*, negative control was PAOΔ*ampRattB::P_{phzA}-lux*.

5.3.6. Primary screen with compounds from Torrey Pines. The primary screen was done using compounds from Torrey Pines. The initial screen was done by measuring the luciferase activity of *P_{ampC}-lux* and *P_{phzA1}.lux* and the compounds. The growth (OD₆₀₀) was measured. The respective controls for each condition will be maintained, for e.g. wells without any small molecule compound were kept. The Torrey Pines Institute chemical library contains around 30 million compounds based upon 40 different molecular scaffolds (Nefzi, *et al.*, 2004). The scaffolds are arranged according to positional scanning format and scaffold ranking, which increases chances of identifying an active compound. The library contains approximately 8000 samples which cover over 30 million compounds. These libraries have been used for drug discovery process as

when compared to other libraries these have the advantage of being able to screen a large number of compounds at the same time (Lopez-Vallejo, *et al.*, 2012). The compounds that show a significant amount of decrease in the luciferase activity and no significant change in OD₆₀₀, will be considered for further screens.

5.3.7 Statistical analysis. In the primary screen with compounds from Torrey Pines, a 20% decrease in luciferase activity considering the positive control as 100% and the negative control as 0% were selected. To assess the assay quality, z' values were quantified in PAO*attB*::P_{ampC}-lux under induction and negative controls PAO*attB*::P_{ampC}-lux without induction using previously described equation (Zhang, *et al.*, 1999). For PAO*attB*::P_{phzA1}-lux, the reporter fusion in *ampR* deletion was considered as negative control. Z' values were considered significant above 0.7.

5.4. Results

5.4.1 AmpR is localized in the membrane. Our previous analysis performed bioinformatically found that AmpR has a transmembrane domain and is membrane associated (Caille, *et al.*, 2014). This was further proven through LacZ-PhoA studies that AmpR has a periplasmic domain (Caille, *et al.*, 2014). Localization was further investigated using protease protection experiments. This showed that incubation with proteinase K resulted in degradation of AmpR found in spheroplasts (Caille, *et al.*, 2014). In this research, we probed the localization of AmpR again using ultracentrifugation which show that AmpR localizes in the membrane. The membrane fractions were

confirmed further using enzyme assays. Lactate dehydrogenase, an enzyme found specifically in the membrane was associated with the AmpR fractions.

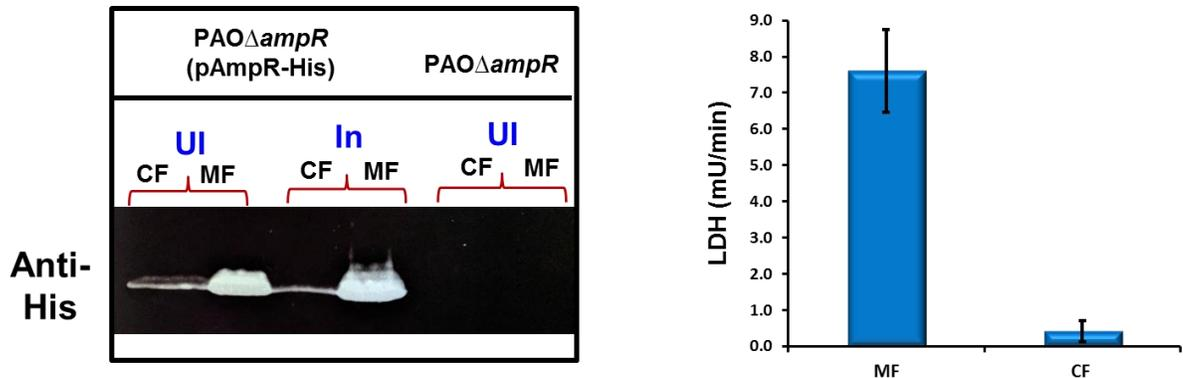

Figure 5.3. AmpR fractionates in the membrane. Fractionation studies using PAOampR (pAmpR-His) found that *P. aeruginosa* AmpR resides in the membrane. The fractions were further confirmed by enzyme analysis. Lactate dehydrogenase is found primarily in the inner membrane in bacteria. Fractions containing AmpR were consistently found to have a higher level of this enzyme when compared with the cytoplasmic fraction. (CF-cytoplasmic fraction, MF- Membrane fraction, UI-U-induced, In-Induced)

5.4.2 Gly102Glu leads to structural instability whereas Asp135Asn stabilizes

AmpR dimer. Previous experiments have indicated that Glycine 102 and Aspartate 135 were critical residues for AmpR to act as an activator of AmpC β-lactamase. Substitution of Aspartate 135 with Asparagine led to an inducer-independent hyper-expression of P_{ampC} (Caille, *et al.*, 2014). It was presumed that this may be due to structural stabilization of the dimer. In the dimer model, residue 135 in the dimer is also located adjacent to one another (Figure 5.4A). Hence, replacing charged amino acid Aspartate with uncharged asparagine leads to structure stabilization of the AmpR dimer model. As this mutation results in constitutive hyper-expression of AmpC, it further supports our hypothesis that AmpR is active as a dimer.

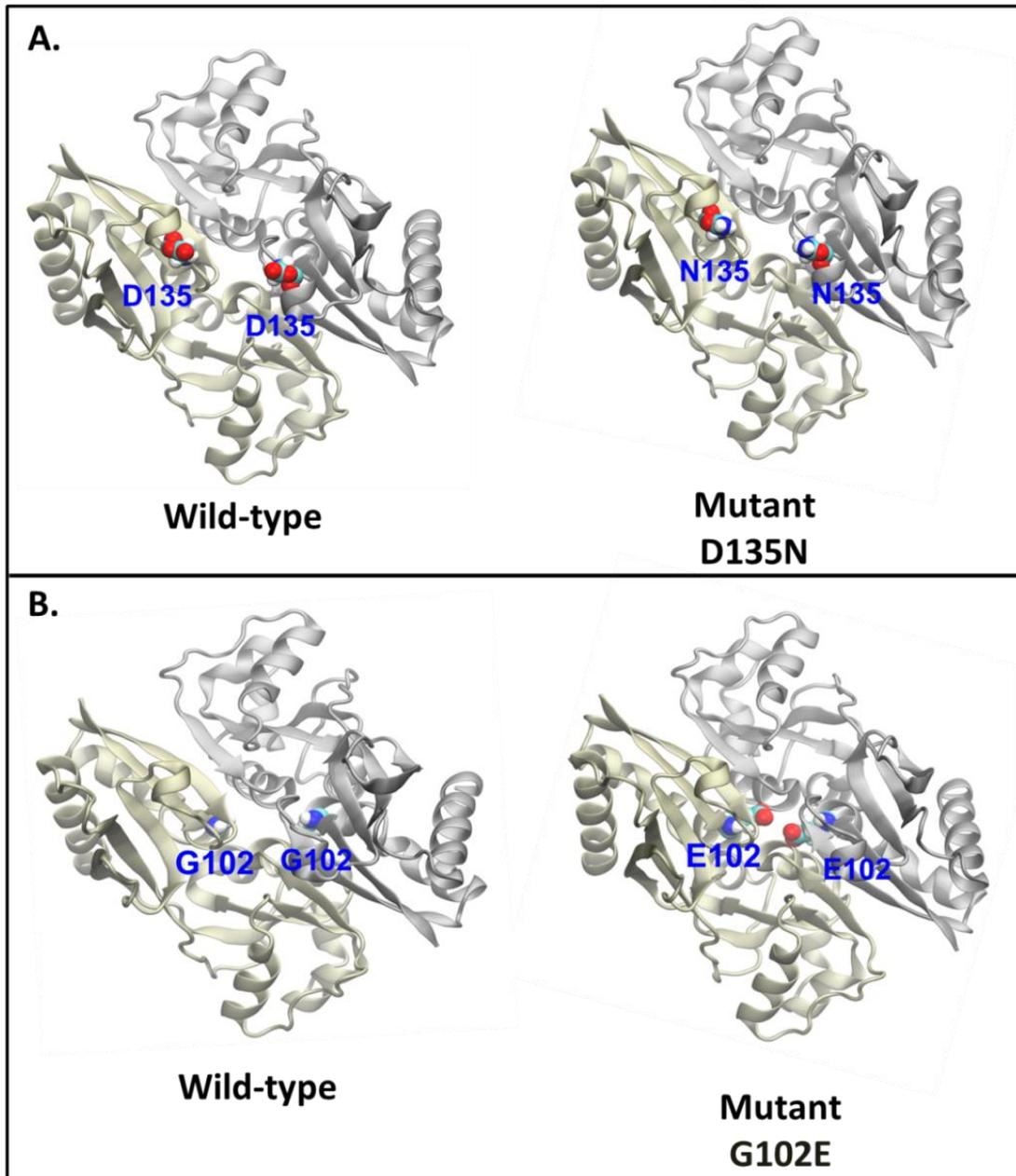

Figure 5. 4. Protein models of AmpR mutants. In panel A replacement of charged Aspartate with Asparagine leads to stabilization of AmpR dimer. This explains the constitutive high-level expression of AmpC. In Panel B, two negative charged E102 residues in the dimer interface will destabilize the dimer due to strong electrostatic repulsion. This explains the loss of phenotype seen in the G102E mutant.

Previous literature in *Citrobacter freundii* has shown that substituting Glycine 102 with glutamate resulted in a constitutive hyper-expression of AmpC (Bartowsky & Normark, 1993). This was however not the case in *P. aeruginosa*, where substitution resulted in an inability to induce AmpC (Caille, *et al.*, 2014). When the structural model was looked at, it was observed that upon AmpR dimerization, the residues 102 of each monomer are closely oriented (Figure 5.4 B). As Glutamate is a charged amino acid, it resulted in the repelling of monomers due to strong repulsive electrostatic interactions and leads to a structural destabilization of the dimer formation, hence leading to a non-inducible phenotype for AmpC. Such destabilization and the detailed atomistic interactions can be explored by performing molecular dynamics simulations.

5.4.3 Validation of reporter constructs. The reporters constructed were validated without compounds to check for luciferase activity. For validation of PAO*attB*::P_{ampC}-lux, the luciferase activity generated over six hours was monitored with a reading taken at every hour. Imipenem which has been demonstrated to be a strong inducer of AmpC activity was used as an inducer. It was found that the activity was highest at 3 hours. The luciferase activity of the PphzA1-lux was compared with and without induction in both PAOI and PAOampR background. It was found that deletion of AmpR abolished luciferase expression, validating its use as a negative control for the reporter PAO1-PphzA1-lux (Figure 5.5).

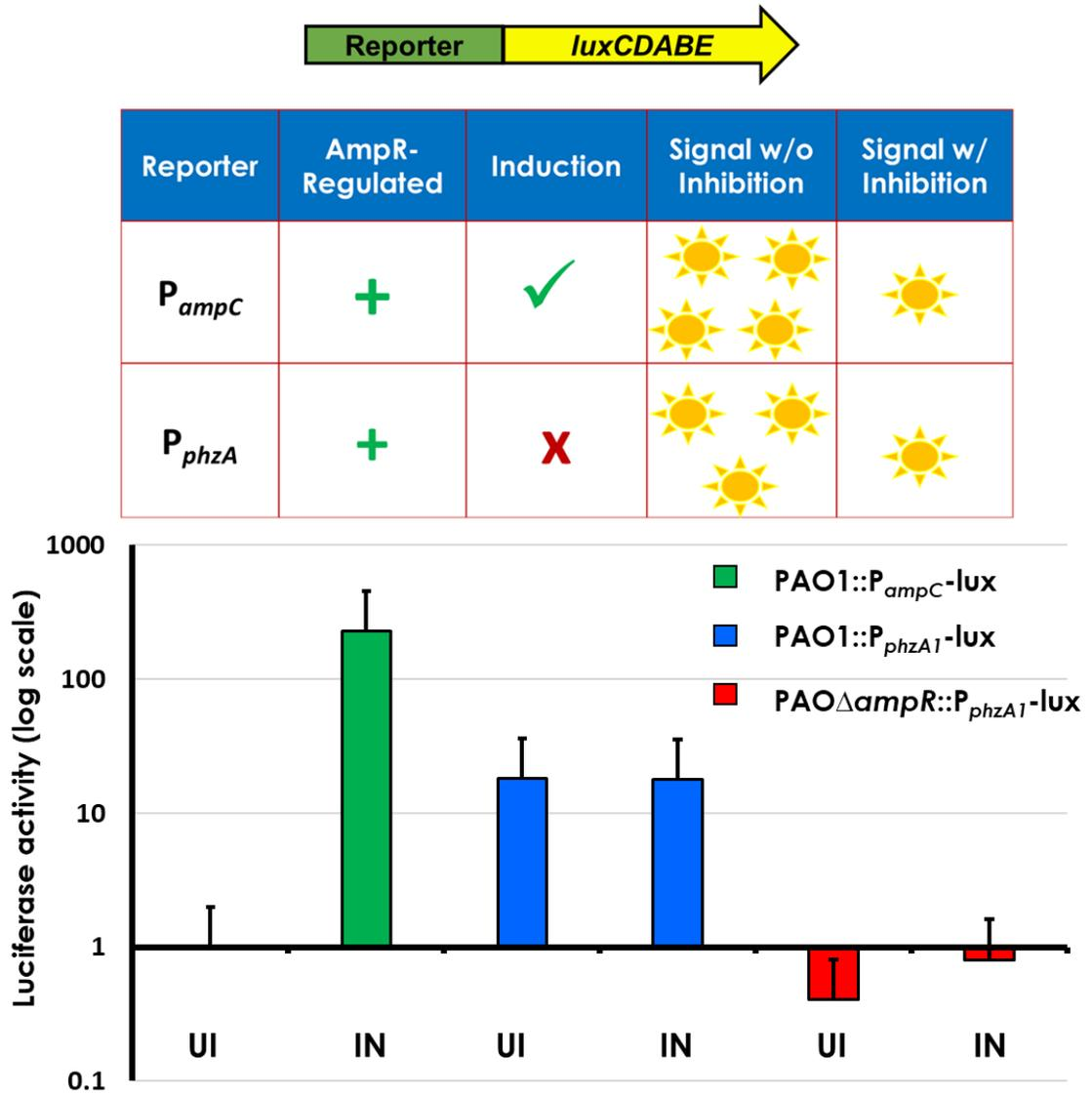

Figure 5.5. Luciferase activity in the reporter constructs. The luciferase activities in the reporters were checked with and without induction. PphzA1 is regulated by AmpR in the absence of induction; as can be seen here. The luciferase detected in the PAO1:: P_{ampC} -lux (UI) and PAO $\Delta ampR$:: P_{phzA} -lux (UI and I) which were our negative controls for each reporter were similar. All values are normalized to PAO:: P_{ampC} -lux uninduced.

5.4.4 Primary screen of Torrey Pines compounds. After validating our reporters with respective controls, PAO::P_{ampC}-lux (Z'=0.88) was used to screen the scaffold-based combinatorial library available at Torrey Pines. The scaffold-based design of the library allows screening for numerous compounds at once. As the compounds were dissolved in Dimethyl formamide (DMF), an initial screening for solvent tolerance was done to determine growth at increasing concentrations of DMF.

Primary screen with the compounds provided a few hits. The analysis of the primary compounds was done at dilutions of 5x and 10x, monitoring the bacterial growth at the same time as luciferase (Figure 5.7). Finally, compounds were used at 10x dilution as that was found to affect growth the least. After normalizing the luciferase activity with growth, compounds that showed 20% decrease in luciferase as compared to the positive control were considered for a secondary screen (Figure 5.8). It was also found that the positive hits could be structurally divided into two groups of pyrrolidine-based and guanidine-based compounds. These were then targeted for a secondary screen using PAO1-P_{ampC}-lux and PAO1-P_{phzA1}-lux.

5.5. Discussion

Genomic and proteomic data from our lab demonstrated the extensive role of AmpR in virulence and antibiotic resistance in *P. aeruginosa* (Balasubramanian, *et al.*, 2012, Balasubramanian, *et al.*, 2014, Kumari, *et al.*, 2014). Much of this data was further confirmed by phenotypic assays (Balasubramanian, *et al.*, 2012). This research explored further into AmpR and its localization in *P. aeruginosa*. The presence of AmpR in the membrane is interesting as transcriptional regulators are typically known to exist in the

<h3 style="text-align: center;">% Reduction in signal : 5x dilution</h3>									
	Compounds								
	1	2	3	4	5	6	7		
A	47	41	-5	-6	8	7	12		
B	39	19	-13	26	33	28	5	DMF	
C	32	13	28	-53	23	28	-2		
D	24	19	-35	-33	2	35	-16		
E	15	30	-24	11	24	-13	-20		
F	25	26	27	23	27	-20	-17		
G	24	14	27	18	23	2	-28		
H	22	14	17	94	-34	-18	-2		
									> 40%
								> 30%	
								Negative	
								Affected growth	

<h3 style="text-align: center;">% Reduction in signal : 10x dilution</h3>									
	Compounds								
	1	2	3	4	5	6	7		
A	58	54	25	22	18	18	25		
B	53	44	27	19	28	22	9	DMF	
C	49	27	17	-4	31	34	8		
D	33	37	21	-13	27	22	12		
E	27	29	-3	20	24	4	2		
F	35	20	34	33	17	-7	2		
G	21	19	23	9	21	-9	4		
H	32	24	28	-32	-3	-10	4		
									> 50%
								> 40%	
								> 30%	
								Negative	
								Affected growth	

Figure 5. 6 Optimizing compound concentrations for screening. Initial screening of compounds was done in both a 5x and a 10x dilution of compounds. 5x dilution with many compounds were found to inhibit growth with no significant effect on luciferase activity. Hence, compounds were used at 10 x dilutions for all subsequent assays.

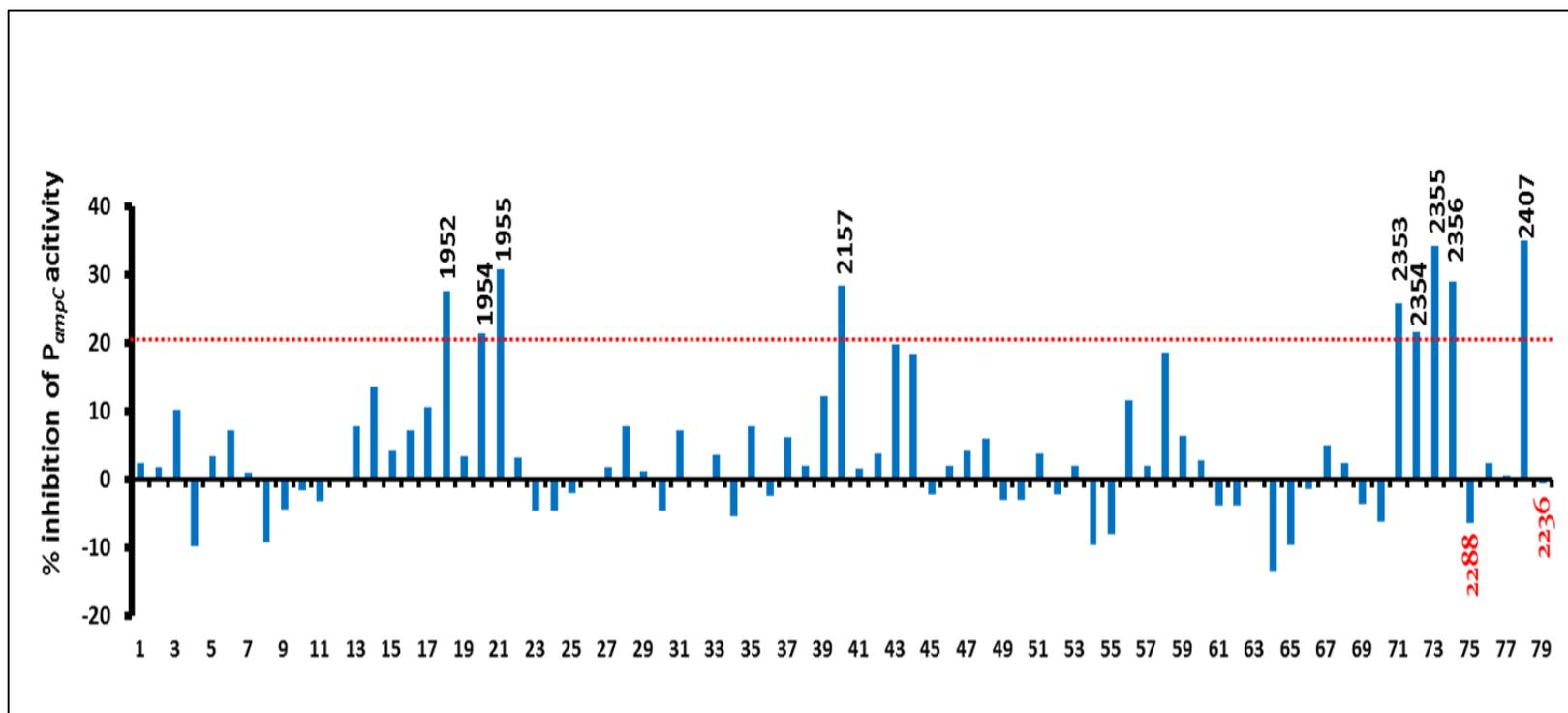

Figure 5.7. Primary screening of scaffold ranking library. Primary screening of the scaffold ranking library using compounds at a concentration of 5 μ M. Samples that inhibited luciferase activity >20% when compared to positive control (PAO1::P_{ampC}-lux, induced) were further analyzed for secondary screening.

cytoplasm. However, previous models of transcriptional regulator in *Rhizobium melliloti* showed the presence of membrane-associated transcription factors, NodD (Schlaman, *et al.*, 1989). The location of AmpR in the membrane also has implications towards the identification or localization of the AmpR effectors (Lee, *et al.*, 2016). The AmpR effectors may be located to the periplasm, in addition to being found in the cytoplasm.

Also, different studies have shown that AmpR exists as a dimer and a tetramer (Vadlamani, *et al.*, 2015, Dik, *et al.*, 2017). Through mutational analyses of selected residues in AmpR, our previous study identified phenotypic differences with regards to AmpC expression (Caille, *et al.*, 2014). The role of the residues was further confirmed with our research here which shows that AmpR is active as a dimer as mutations of G102Glu results in de-stabilization of the dimer and Asp135Asn leads to stabilization of the dimer. This occurs due to the gain or loss of charged amino acids, which results in increased and decreased electrostatic repulsion, respectively.

It is known that AmpR along with other members of the cell-wall recycling pathway regulate β -lactam resistance (Johnson, *et al.*, 2013). Our principle for advocating AmpR as a novel antibacterial target was to identify inhibitors that reduce virulence as well as prevent induction of AmpC β -lactamase thereby helping in a synergistic action with β -lactams. We also developed a novel cell-based screening with reporters using luciferase. Previous knowledge regarding the AmpR regulon led us to use AmpC promoter for the constructing the reporter screen (Balasubramanian, *et al.*, 2012). In addition, other promoters known to be regulated by AmpR such as PhzA1 and MexE were developed for counter-screening (Balasubramanian, *et al.*, 2012). Transcriptional fusions were generated with these promoters with the *luxABCDE* operon. The primary screens identified compounds that belonged to two distinct chemical compounds,

pyrrolidine and guanidine-based compounds. Using this information, we can identify compounds with similar structures that may specifically inhibit AmpR. Secondary screening of the compounds identified so far can be done with the second reporter system P_{phzA1} . Furthermore, as the effectors of AmpR have been identified in our previous studies, our reporter system can be used for a more targeted approach to identify muramyl-peptide analogs inhibiting AmpR.

5.6 Acknowledgements. The structural modeling was done in collaboration with Dr. Prem Chapagain and Dr. Jeevan GC at Department of Physics with College of Arts, Sciences and Education at Florida International University. The screening for small-molecules was done in collaboration with Torrey Pines Institute, Florida. We are grateful to Dr. Mark Guilanotti for providing us the compounds as well as intellectual input and discussions.

Chapter 6

Overview, Summary and Future Directions

6.1. Overview

Pseudomonas aeruginosa is a Gram-negative, metabolically-versatile, ubiquitous bacterium that is known for causing life-threatening infections in immunocompromised people (Eng, *et al.*, 1986, Kiehn, 1989). Commonly identified as a soil microbe, the incredible ability of these bacteria to adapt and thrive in diverse environments has contributed to its success as an important pathogen (Govan & Harris, 1986, Silby, *et al.*, 2011, Marvig, *et al.*, 2015, Winstanley, *et al.*, 2016). Although rare, *P. aeruginosa* can cause infections such as folliculitis, otitis externa, and keratitis in healthy individuals (Ramphal, *et al.*, 1981, Mena & Gerba, 2009). In addition, *P. aeruginosa* is one of the main pathogens that account for most of the hospital-acquired infections (Pittet, *et al.*, 1999, Cadro, 2004). Other serious infections in patients include burn-wound or post-surgery which leads to bacteremia that may proceed to fatal sepsis (McManus, *et al.*, 1985, Osmon, *et al.*, 2004, Yildirim, *et al.*, 2005). Age, prolonged intubation, chemotherapy, HIV AIDS as well as the use of broad spectrum antibiotics can result in lowering immunity leading to the manifestation of *P. aeruginosa* infection (Kielhofner, *et al.*, 1992, Caselli, *et al.*, 2010). A notable disease that is almost always associated with *P. aeruginosa* is cystic fibrosis (Emerson, *et al.*, 2002, Marshall, *et al.*, 2016).

Complicating *P. aeruginosa* infections is its remarkable intrinsic ability to thwart multiple antibiotics (Lambert, 2002, Livermore, 2002). This single species harbors numerous resistance mechanisms which include impermeability of the outer membrane, active efflux of small molecules via efflux pumps, modification of the antibiotic target rendering them unrecognizable and the production of hydrolytic enzymes specifically, towards a group of drugs often used, the β -lactams (Hancock, 1998, Livermore, 2002, Fisher, *et al.*, 2005).

A major mechanism of resistance specific to β -lactams is the expression of hydrolytic enzymes that cleave the β -lactam ring rendering them ineffective. *P. aeruginosa* harbors chromosomally encoded β -lactamases. However, it easily acquires genes via horizontal transfer as well as plasmid, transposon or integron encoded (Zhao & Hu, 2010, Breidenstein, *et al.*, 2011). These enzymes include the Class A and D extended spectrum β -lactamases as well as the Class B carbapenemases (Paterson & Bonomo, 2005, Poirel, *et al.*, 2010, Poole, 2011). In addition to these, three β -lactamases are encoded on the *P. aeruginosa* genome. This includes PIB-1/PA5542; Class D oxacillinase PoxB/PA5297, formerly known as OXA-50, and the Class C cephalosporinase AmpC/PA4110 (Kong, *et al.*, 2005, Fajardo, *et al.*, 2014, Zincke, *et al.*, 2016). PoxB was recently characterized by our lab as a carbapenemase which leads to resistance, especially upon down-regulation of the porin OprD whereas PIB-1 was found to be a zinc-dependent imipenemase (Fajardo, *et al.*, 2014, Zincke, *et al.*, 2016).

The third chromosomal β -lactamase, AmpC (PA4110) is well-characterized in *P. aeruginosa* and is known to be regulated by the transcriptional factor AmpR (PA4109) (Lodge, *et al.*, 1993, Kong, *et al.*, 2005). Expression of *ampC* is inducible in the presence of certain β -lactams and requires AmpR and its effector, a mucopeptide generated by the concerted activity of the proteins in the cell-wall recycling pathway (Jacobs, *et al.*, 1997, Dhar, *et al.*, 2018). Cell-wall recycling is a process that is conserved in both Gram-positive and -negative bacteria (Reith & Mayer, 2011, Johnson, *et al.*, 2013). Recycling of the cell-wall that occurs during growth, division and elongation was eventually linked to its intrinsic role in AmpC induction and hence, β -lactam resistance (Goodell & Schwarz, 1985, Lindquist, *et al.*, 1989). The link between the two processes was suggested when it was discovered that the signaling molecules which interact with AmpR were not β -lactams but were speculated to be the cell-wall fragments generated

in the presence of β -lactams (Lindquist, *et al.*, 1989). This hypothesis was confirmed when it was identified that AmpG and AmpD were required for *ampC* expression in *C. freundii* and *E. cloacae* and that these genes were also involved in recycling of cell-wall fragments or muropeptides (Korfmann & Wiedemann, 1988, Korfmann & Sanders, 1989, Lindquist, *et al.*, 1989, Jacobs, *et al.*, 1994).

Since then cell-wall recycling has been studied mainly in *E. coli* (Park & Uehara, 2008). However, to better understand the details of this induction process special focus has been given to pathogens that contain the *ampR-ampC* region, including members of Enterobacteriaceae and in *P. aeruginosa* (Jacobs, *et al.*, 1994, Balasubramanian, *et al.*, 2015). Many proteins of cell-wall recycling such as the lytic transglycosylases, amidases, permeases, N-acetyl β -D glucosaminidases, and ligases are involved in the AmpC induction process (Kong, *et al.*, 2010, Dhar, *et al.*, 2018). Among these, in *P. aeruginosa* mutations of specific ones such as amidases- AmpDh2, AmpDh3 and AmpD; LMM penicillin-binding proteins; N-acetylglucosaminidase NagZ; permease AmpG have been shown to affect AmpC expression (Juan, *et al.*, 2006, Kong, *et al.*, 2010, Johnson, *et al.*, 2013, Ropy, *et al.*, 2015). Many of these enzymes play a seminal role in generating the muropeptide effector of *P. aeruginosa* AmpR as has been entailed in some detail in Chapter 1 (Juan, *et al.*, 2006, Asgarali, *et al.*, 2009, Kong, *et al.*, 2010). However, to date the muropeptides generated in *P. aeruginosa* as well as the identity of the AmpR effector remains elusive.

This dissertation delved into the role of cell-wall recycling intermediates as determinants of β -lactam resistance in *P. aeruginosa*. This work investigated for the first time muropeptides and their structure in *P. aeruginosa* and identified the specific muropeptides that act as AmpR effectors. In addition, the role of AmpG and AmpP in the

transport of muropeptides was analyzed in *P. aeruginosa*. We identified disaccharide muropeptides as the substrates for these permeases. The identity of a putative *N*-acetylglucosaminidase was investigated. Finally, reporters were constructed to screen for small-molecule inhibitors for AmpR.

6.2. Muropeptides in *P. aeruginosa* and AmpR effector. Cell-wall intermediates are often generated when the cell divides. These products are released from the peptidoglycan wall and structurally are composed of variations of sugars and peptides (Glauner, *et al.*, 1988). The sugars include *N*-acetylglucosamine (GlcNAc) and *N*-acetyl muramic acid (MurNAc) and the peptides are composed of L-alanine, γ -D-glutamine, *meso*-diaminopimelic acid (*m*-DAP), and D-alanine (Glauner, *et al.*, 1988). The composition of the PG is conserved mostly across Gram-negative bacteria (Schleifer & Kandler, 1972, Vollmer & Holtje, 2004). The main variation found in Gram-positive bacteria is the presence of L-Lysine in place of *m*-DAP as the third amino-acid of the peptide chain (Schleifer & Kandler, 1972).

In *P. aeruginosa* PAO1 we were able to detect upto 20 distinct muropeptides using liquid chromatography with tandem mass-spectrometry (Chapter 2, Table 2.2). A method to quantitate the muropeptides was developed. For our study, we used *P. aeruginosa* at late-log phase of growth to investigate the muropeptide levels. It is well-appreciated that the PG undergoes structural modifications based upon the phase of bacterial growth. In *E. coli* it was found that bacteria in the exponential phase of growth had higher cross-linked muropeptides compared to one that is not dividing (Glauner, *et al.*, 1988, Keep, *et al.*, 2006). *In vitro* activity of PG degradative enzymes such as the lytic transglycosylases on the isolated murein sacculus at log-phase led to a higher level of muropeptide products compared to one obtained at stationary phase (Lee, *et al.*, 2013). In our

research, a protocol was developed wherein we can isolate and detect muropeptides using LC/MS/MS from bacterial extracts. This work was done in collaboration with Dr. Mobashery's lab at UND. The conditions used for LC/MS were established previously and we were able to identify muropeptides up to picomolar concentration (Lee, *et al.*, 2013). The muropeptides that were generated are the results of numerous enzymes found in the cytoplasm and the periplasm (Chapter 1, Table 1.2). Using synthetic standards of muropeptides available with our collaborator, we were able to quantitate the absolute number of muropeptides (molecule/cell) in the bacterial cell (Chapter 2, Table 2.1).

The total ion chromatogram (TIC) did not reveal any specific muropeptide; hence extracted ion chromatogram was used and muropeptides detected using synthetic muropeptides (Chapter 2, Figure 2.3). The most abundant muropeptide detected was the disaccharide-tetrapeptides (N-acetylglucosamine- 1, 6 anhydro MurNAc L-Ala-D-Glu-*m*-DAP-D-Ala) (Chapter 2, Table 2.1). Disaccharides with varying number of amino-acids were detected; however, pentapeptide which is the full amino acid side chain was present in minute quantities. These were the products of lytic transglycosylase with exolytic activities. So far, *P. aeruginosa* has shown the presence of eleven LTs all of which have shown to have exolytic activity (Lee, *et al.*, 2017). Monosaccharides such as 1, 6 anhydro MurNAc tri and tetrapeptides were also detected indicating the presence of *N*-acetylglucosaminidase. Identification of 1, 6 anhydroMurNAc peptides in the periplasm led us to postulate the presence of a second *N*- acetylglucosaminidase, FlgJ. The role of this enzyme in cell-wall recycling and antibiotic resistance is the focus of chapter 4.

Presence of a cell-wall active drugs such as β -lactams in the environment trigger the generation of certain muropeptides that act as AmpR effectors (Jacobs, *et al.*, 1997).

The bacteria grown in LB media without β -lactam were compared with the bacteria exposed to non-lethal concentration of β -lactam (cefoxitin). Cefoxitin is a strong inducer of β -lactamase and more stable to its hydrolytic activity (Jacoby, 2009). Overall, it was found that the levels of muropeptides upon β -lactam induction were decreased (Chapter 2, Table 2.1). Relative levels of individual muropeptides were similar; however, one discriminatory feature was consistently increased presence of pentapeptides upon induction. There was a 46-fold induction of *N*-acetylglucosamine 1, 6 anhydro *N*-acetyl muramic acid pentapeptide in the presence of β -lactam stress and the 1,6 *N*-acetyl muramic acid pentapeptide was detected only upon induction. This increase probably occurs as cefoxitin acts by targeting PBPs. Upon binding with low molecular mass PBPs (LMM PBP), both the transpeptidase and endopeptidase functions of these enzymes are lost, and there is an increase of their specific substrates (Lee, *et al.*, 2015). In such cases, the pentapeptide containing muropeptides (substrates of LMM-PBP) may increase relatively in the cytosol. As there was a significant increase in the levels of the pentapeptides upon induction, it was further analyzed if these muropeptides act as AmpR effector. A β -lactamase assay with synthetic constructs indeed revealed that these muropeptides were capable of inducing β -lactamase expression (Chapter 2, Figure 2.3). A subsequent study also confirmed our findings by clearly elucidating the binding and interaction of these muropeptides with AmpR (Dik, *et al.*, 2017).

P. aeruginosa cell-wall recycling has been found to deviate from that of Enterobacteriaceae. *P. aeruginosa* has multiple amidases whose down regulation is required for the maximal β -lactamase expression (Juan, *et al.*, 2006). It has two inner membrane permeases hypothesized to play a role in cell-wall recycling in *P. aeruginosa* (Kong, *et al.*, 2010). AmpR itself in *P. aeruginosa* has been found to have a more extensive regulon when compared to its counterpart in *E. cloacae* and *C. freundii*

(Balasubramanian, *et al.*, 2015). Previous research in *C. freundii* had shown that the 1, 6 anhydro muramic acid tripeptide can act as the AmpR effector (Jacobs, *et al.*, 1994). This was however not found to be the case in *P. aeruginosa* (Chapter 2, Table 2.2).

6. 3. AmpG and AmpP play a role in cell wall recycling. *P. aeruginosa* has two *E. coli* AmpG homologs, PA4393/AmpG and PA4218/AmpP. The MIC of certain β -lactams was decreased in PAO Δ ampG (Chapter 3, Table 3.1). This decrease in MIC can be explained by the diminished levels of β -lactamase expressed in PAO Δ ampG (Chapter 3, Figure 3.2). It is known that AmpG is conserved across many Gram-negative bacteria and plays a role in muropeptide transport (Li, *et al.*, 2016, Perley-Robertson, *et al.*, 2016). Based on our previous research and significant homology of AmpP with *E. coli* AmpG, we also hypothesized that AmpP plays a role in muropeptide transport, probably by shuttling muropeptides from the cytoplasm into the periplasm (Kong, *et al.*, 2010). When the muropeptides levels were compared between the different fractions, it was found that disaccharides accumulate in the periplasm and cytoplasm respectively in PAO Δ ampG and PAO Δ ampP (Figure 3.8). This suggests that these permeases play a role in transporting disaccharide-peptides into and out of the cytoplasm. When the periplasmic extract of muropeptides was isolated, mostly disaccharides were detected in all strains as compared to the whole cell preparation (Figure 3.5). This is expected as the enzyme *N*-acetylglucosaminidase that cleaves the two sugar units GlcNAc and MurNAc, is known to be cytosolic. However, a minor amount of monosaccharides were found in all the periplasmic preparation, indicating the presence of a putative periplasmic *N*-acetylglucosaminidase (Figure 3.6). Larger peptides that included the cross-linked and the tetrasaccharide peptides were also detected at higher levels in the preparation used

for whole cell extracts (Figure 3.7). This probably reflects the type of preparatory method used for isolating whole-cell muropeptides, as it involves sonication whereas the periplasmic preparation is done by a gentler osmotic shock. To summarize, our analyses showed the presence of muropeptides in both whole-cell as well as periplasmic preparation. Distinctions between mutant strains were made at relative levels of individual muropeptides. Increased levels of periplasmic disaccharide-muropeptides were found in *ampP* and double-deletion strains whereas decreased levels were seen in *ampG* deletion strains. This indicates that AmpP can transport muropeptides from the cytoplasm into the periplasm. This method of muropeptide analysis can be used to analyze relative levels or trends of individual muropeptide or to detect presence or absence of specific muropeptides between different strains.

6.4. Role of PA1085 in *P. aeruginosa*. PA1085 is the fifth gene of a seven-gene operon in *P. aeruginosa* and is involved in flagellar biosynthesis and assembly. *P. aeruginosa* is a monotrichous organism and motility is one of its primary virulence factors (Gellatly & Hancock, 2013). In our previous analyses of muropeptides, we were able to consistently detect monosaccharide muropeptides in the periplasmic space indicating that there may be a periplasmic enzyme that generates these products from the peptidoglycan (Lee, *et al.*, 2016). The only characterized *N*-acetylglucosaminidase in *P. aeruginosa* is NagZ (PA3005) which is cytosolic. It was found that a periplasmic homolog of this enzyme as characterized in *S. enterica* known as *flgJ*. This enzyme is part of the flagellar operon and is hypothesized to hydrolyze the PG and enables the insertion of the flagellar units into the PG and its extrusion through the outer membrane into the extracellular milieu (Kerridge, *et al.*, 1962, Herlihey, *et al.*, 2014). *In-silico* analysis of the *P. aeruginosa*

PAO1 genome led to the identification of PA1085. There was 31% homology between FlgJ of *P. aeruginosa* and *S. enterica*. Sequence alignment also showed that the residues that are required for this activity were conserved between *P. aeruginosa* and *S. enterica* FlgJ. In an effort to understand the role of *flgJ* in *P. aeruginosa*, an in-frame deletion mutant was constructed. It was found that with the loss of *flgJ*, swimming activity was affected whereas swarming and twitching were not (Figure 4.3). Motility also influences other phenotypes such as biofilm formation (O'Toole & Kolter, 1998). Loss of *flgJ* resulted in an increase in biofilm over 48 hours (Figure 4.4). NagZ (PA3005) in *P. aeruginosa* is required for maximal β -lactamase expression and its absence leads to a decrease in MIC towards selected antibiotics. (Asgarali, *et al.*, 2009). However, deletion of *flgJ* did not lead to any changes in the MIC of antibiotics (Figure 4.5). The levels of *N*-acetylglucosaminidase in whole-cell extracts were also unchanged with the loss of FlgJ (Figure 4.6).

6.5. Screening of small molecule library for AmpR inhibitors. The premise for this aim is built upon the previous research which demonstrated that AmpR has an expansive regulon in *P. aeruginosa* and is connected to various virulence and antibiotic resistance regulatory networks (Balasubramanian, *et al.*, 2012). For the identification of AmpR inhibitors, we developed a reporter assay using the luciferase operon *luxCDABE* fused to promoters known to be regulated by AmpR (Becher & Schweizer, 2000). The reporter used for the primary screening was P_{ampC} -*luxCDABE* (Figure 5.2). The luciferase assay was used as it is a one-step assay which does not require any manipulation such as addition of exogenous substrate or an inducer (Craney, *et al.*, 2007). Using this system, a primary screening was initiated with the scaffold based

combinatorial library available at Torrey Pines Institute that allows the screening of millions of compounds arranged around 79 core scaffolds. The primary screening of the library was done at a final concentration of 5 μ M of the compounds, monitoring the growth of bacteria at the same time. Samples that inhibited P_{ampC} activities by 20-40% when compared to the positive control were analyzed further (Figure 5.8). Based on the core structures, the samples that showed inhibition were either guanidine or pyrrolidine-based. This corroborates with a recent study which used this chemical library and identified a guanidine based compound with anti-bacterial activity against all the ESKAPE (**E**-*Enterococcus faecium*, **S**-*Staphylococcus aureus*, **K**-*Klebsiella pneumoniae*, **A**-*Acinetobacter baumannii*, **P**- *Pseudomonas aeruginosa*, **E**-*Enterobacter* species) pathogens (Fleeman, *et al.*, 2015). Pyrrolidine-based compounds synthesized in-house have previously been demonstrated to be inhibitors of quorum sensing. Our previous research also identified AmpR as a regulator of QS. It would be interesting to further determine if the pyrrolidine compounds available from Torrey-Pines available are AmpR-specific and QS inhibitors.

6.6 Future directions

This research is one of the first reports of the mucopeptides identified in *P. aeruginosa* using LC/MS/MS. It is also the first report that demonstrated a method to quantitate mucopeptides without radioactive-tagging as well as reported on the structural nature of the individual mucopeptides. We studied the effect of β -lactams on mucopeptide levels and the identity of the AmpR effector. This research led to the advent of many unanswered questions. The gaps in knowledge have been addressed in sections. The first part deals with the study of mucopeptides in *P. aeruginosa* and its

relevance to antibiotic resistance. Following are further ideas that can be pursued to illustrate better the relevance of muropeptides in *P. aeruginosa*.

I. Investigate muropeptides in clinical-strains and correlate with virulence in host.

Muropeptides generated during cell-wall recycling and synthesis may differ among the different *P. aeruginosa* strains. As muropeptides are significant in maintaining virulence, it would be pertinent to investigate their levels in clinical isolates. In this research we used PAO1 and its isogenic mutants for all our investigations (Lee, *et al.*, 2016). Future studies should elucidate the muropeptide levels, found intracellularly and the muropeptides released into media from *P. aeruginosa* clinical-isolates. A correlation between the released muropeptides and disease phenotypes has been demonstrated in pathogens such as *Bordetella pertussis*, *Neisseria gonorrhoea*, and *N. meningitidis* (Cookson, *et al.*, 1989, Chan & Dillard, 2016). Such an investigation can be undertaken using clinical isolates of *P. aeruginosa* and the trend of muropeptides generated therein compared with the lab strain PAO1. The protocol developed in the current study to isolate and quantitate muropeptides can be used for the different strains. Future studies can determine whether the structural nuances, levels, and composition of muropeptides alter the pathogenesis of the organism and the interaction with host receptors. This can be done by incubating an immune cell line such as the Mono Mac 6 (MM6) cells or the human embryonic kidney cell line (HEK293T) with muropeptides followed by evaluation of the gene expression levels of Tumor Necrosis Factor- α (TNF- α) (Wolfert, *et al.*, 2007). TNF- α is known to be stimulated when exposed to muropeptides (Wolfert, *et al.*, 2002). Alternatively, stimulation of the NOD receptors can be investigated in HEK-Blue hNOD1 and HEK-Blue hNOD2 reporter cell lines (Torrens, *et al.*, 2017).

- II. The mechanistic details of the interaction of muropeptide with receptors of the immune system can be investigated.

It is well appreciated that specific muropeptides such as the muramyl dipeptides are recognized by immune receptors in host such as NOD1, NOD2, Cryopyrin and Toll-like receptors among others (Wolf & Underhill, 2018). The mechanism of binding and interaction of the muropeptides with these host receptors can be investigated.

- III. Investigate the expression of cell-wall recycling genes in different strains.

A hallmark feature of *P. aeruginosa* is genetic adaptation found within a strain, depending on whether it causes an acute versus a chronic infection (Klockgether & Tummler, 2017). For instance, the expression of the genes in the cell-wall recycling pathway may be different in an alginate producing strain, a phenotype found often in chronic infections. The muropeptide profile of a hyper-alginate producer PDO300 can be compared with that of non-alginate strain PAO1 (Mathee, *et al.*, 1999). In addition, the extent of sequence conservation of the cell-wall recycling genes in clinical isolates can be discerned by *in silico* analyses using PAO1 as the reference strain. This can be followed up by comparing the expression of cell-wall recycling genes of these strains under different growth conditions.

- IV. Changes in muropeptide profile when exposed to a different antibiotic as well as experimental analysis of muropeptide-AmpR binding.

In this study we established that the total levels of muropeptide change in the presence of an inducer such as cefoxitin which is known to be a strong inducer of AmpC β -lactamase (Jacoby, 2009). The changes in the muropeptide profile when *P. aeruginosa* is exposed to sub-lethal concentrations of β -lactams such as cefotaxime, ceftriaxone and ceftazidime which are not strong inducers of AmpC β -lactamase can

be investigated (Jacoby, 2009). It will be interesting to note the changes in the muropeptide profile and to determine the generation of AmpR under these conditions. Furthermore, it was established that GlcNAc 1, 6 anhMurNAc pentapeptide and 1, 6 anhMurNAc pentapeptide were able to bind with the AmpR effector binding domain using molecular dynamic simulation and non-denaturing mass-spectrometry (Dik, *et al.*, 2017). An *in vivo* cross-linking study followed by pull-down of AmpR using specific antibodies can be also done to confirm these muropeptides as effectors. Previous study using molecular simulation dynamics focused on the important residues for effector binding in *P. aeruginosa* AmpR (Dik, *et al.*, 2017). Using site-directed mutagenesis, these residues can be replaced to determine their effect on AmpC expression.

The second part of the research dealt with the role of AmpG and AmpP in *P. aeruginosa* as muropeptide transporters. This was the first attempt of looking at these transporters in an *in vivo* setting. However, there are still unanswered questions.

- I. Role of AmpP as a muropeptide transporter can be confirmed with a transport assay.

This research elaborated on the role of the permeases AmpG and AmpP in *P. aeruginosa*. Further investigation can be done to confirm our hypothesis that AmpP acts a disaccharide-muropeptide exporter to the periplasmic space. As a previous study using fluorophore-conjugated muropeptides has shown that AmpP is unable to import disaccharide-muropeptides, in future (Perley-Robertson, *et al.*, 2016) it can be assessed whether AmpP can export muropeptides from the cytoplasm, by monitoring the levels of fluorescence in the media, in the absence and presence of *ampP* expression.

- II. Role of AmpG and AmpP in antibiotic resistance and recycling can be studied in clinical-isolates of *P. aeruginosa*.

The extent of conservation of these two proteins involved in cell-wall recycling has not been studied yet. As this study primarily looked at the recycling pathway in PAO1, in future other clinical isolates and strains of *P. aeruginosa* and the role of AmpG and AmpP therein can be analyzed

- III. Role of FlgJ as an *N*-acetylglucosaminidase can be confirmed through protein purification.

In the current study, we used an *in-frame* deletion mutant of *flgJ* to identify whether it was involved in producing *N*-acetylglucosaminidase and antibiotic resistance. However, we were unable to obtain any clear results. A better approach may be to purify this protein and study its activity on purified PG. The products generated in this reaction can be studied using LC/MS. This would not just confirm FlgJ as an *N*-acetylglucosaminidase but would also extend to identifying if it has any other alternate enzyme activity.

- IV. Besides FlgJ other putative *N*-acetylglucosaminidase can be mapped and investigated.

It may be that FlgJ is not an *N*-acetylglucosaminidase. In that case there must be an alternate enzyme that is generating the monosaccharides. One of the future directions will be to analyse the genome for any paralogs of FlgJ as well as NagZ. Similarities will also be chalked out according to the domains of the enzymes.

- V. Analyze for an alternate transporter that shuttles monosaccharides into the periplasm.

Another possibility is that the periplasmic monosaccharides are not being generated there, but cytoplasmic ones are being transported into the periplasmic space. This

would mean that similar to inner membrane permease AmpP which can transport disaccharides, there may be another permease which can transport monosaccharides. It may be useful to do bioinformatically analyze whether there any other inner membrane permeases that show homology with AmpG and AmpP.

The third part of the research investigated small-molecule inhibitors of an important virulence factor in *P. aeruginosa* known as AmpR. We were able to identify inhibitors through primary screening of compounds using our luciferase reporters. Following steps are further required to complete the investigation.

- I. Identify individual family of drugs by secondary screening.

Secondary screening will be done with the individual family of drugs that were identified. Alternate promoter fusions P_{phzA1} and P_{mexE} will be used to confirm that inhibition of luciferase activity occurs by AmpR inhibition. AmpR is known to regulate *phzA1* and *mexE* expression, positively and negatively (Balasubramanian, *et al.*, 2012). Hence, the compounds identified so far, that decrease *phzA1* expression and increase *mexE* expression, as inferred from luciferase activity, will be most likely AmpR inhibitors. Compounds selected post-secondary screening wherein scaffolds that inhibited AmpR activity will be further scrutinized using different functional groups.

2. Synthesize and investigate the activity of individual drugs using tertiary screening.

The deconvoluted hits from the secondary screening will determine the individual compounds that will be screened on a tertiary screen. For this, individual compounds previously identified will be synthesized and their activity as luciferase inhibitors will be checked using all three promoter systems.

Following the identification of individual compounds and their analysis as AmpR inhibitors, they will be further analysed for properties regarding their effects on resistance and virulence. This will include the following analysis:

MIC and synergy test: The MIC of the individual compound will be analysed by monitoring OD₆₀₀ by broth microdilution analysis (EUCAST, 2000). The synergistic effect of these compounds with commonly used *P. aeruginosa* antibiotics such as β -lactams, fluoroquinolones, and aminoglycosides will also be investigated using checkerboard assays (Doern, 2014).

Cytotoxicity assay: After the synthesis of the individual compounds, the cytotoxicity will be ascertained by a XTT based assay (Page, *et al.*, 1993).

Canorhabditis elegans assay: *C. elegans* has been established as a good model for analysis of *P. aeruginosa* pathogenesis (Tan, *et al.*, 1999, Balasubramanian, *et al.*, 2012). Compounds selected so far will be tested for their effect on *C. elegans* by the fast- and slow-killing methods (Brenner, 1974).

The compounds selected will be analysed for their AmpR inhibition in clinical isolates of *P. aeruginosa*. This will include PA14, mucoid strain such as PA2192, Liverpool LES and PA7.

Appendix

L-arginine regulates *Pseudomonas aeruginosa* pathogenesis through quorum sensing

Supurna Dhar, Katherine Vandenburg Veronica Perez, Emmanuel Duarte, Horatio Priestap, Kalai Mathee, Amir Khodamzaddeh

Abstract

With the current widespread abuse and overuse of broad-spectrum antibiotics, resistance among bacteria is increasing at an alarming rate. Besides, the classical antibiotics that are either bacteriostatic or bactericidal, alternate targets and pathways that diminish bacterial pathogenicity are being sought after. One of these alternate approaches focusses on impeding the communication that takes place through chemical signaling between bacteria also known as quorum sensing (QS). This practice is called anti quorum-sensing. *Panax ginseng* is a well-established inhibitor of quorum sensing. However, previous studies were unable to decipher the active chemical compound in these extracts that was responsible for the anti-quorum sensing property. One of the compounds that were identified in ginseng extracts in high concentrations was L-arginine (~80 mM). Further analysis with this particular amino acid on *Chromobacterium violaceum* showed a significant inhibition of QS regulated violacein production. In this study, L-arginine was further examined for its effects on the QS phenotypes using the opportunistic pathogen, *Pseudomonas aeruginosa* as a bio-monitor strain. L-arginine was found to reduce multiple QS regulated virulence factors as well as levels of Acyl Homoserine Lactone (AHL) which is one of the signaling molecules involved in QS.

Keywords: Virulence, proteases, biofilm, amino acid

Introduction

The role of *Pseudomonas aeruginosa*, a major nosocomial pathogen is well-established in critical infections of the respiratory tracts including pan bronchiolitis, chronic obstructive pulmonary disorder, and pneumonia which are characterized by complicated treatment and often therapeutic failure (Garau & Gomez, 2003, Valderrey, *et al.*, 2010). This is especially seen in cystic fibrosis patients in whom chronic colonization of *P. aeruginosa* in the lungs is the result of this pathogen's inherent and acquired capacity to resist conventional antibiotic treatment (Lyczak, *et al.*, 2000, Lyczak, *et al.*, 2002, Jansen, *et al.*, 2016).

With accelerated antibiotic resistance, the discovery of novel antibiotics must be prioritized (Silver, 2011). A novel approach to anti-bacterial drug discovery is to look for compounds that, without killing the bacteria maim its capacity to establish infections. As the process interrupted therein is not essential for the pathogen's survival, it does not evoke evolutionary responses from the bacteria to develop resistance, thereby increasing the long term chances of therapeutic success (Pepper, 2008, Brown, *et al.*, 2009).

One such alternative target is the quorum sensing (QS) mechanism (O'Loughlin, *et al.*, 2013, Eibergen, *et al.*, 2015, Ali, *et al.*, 2017). QS is a form of bacterial communication achieved through the production and secretion of chemical signals. *P. aeruginosa* has four systems regulating quorum sensing: Las, Rhl, Pqs, and IQS (Lee, *et al.*, 2013). The synthases in each system produce small molecules 3-oxo-C12-homoserine lactone (C12-HSL), N-butanoyl-homoserine lactone (C4-HSL), 2-heptyl-3-hydroxy-4-quinolone (PQS) and 2-(2-hydroxyphenyl)-thiazole-4-carbaldehyde, respectively (Papenfort & Bassler, 2016). Conventionally, *P. aeruginosa* QS was known

to exhibit hierarchy with Las system at the top of the series; however, current research suggests that regulator RhIR can affect the expression of certain target genes of the Las system (Pesci, *et al.*, 1997, Dekimpe & Deziel, 2009).

The signature signal is species specific and cross-communication may occur (Bassler, *et al.*, 1997). These chemical signals allow large populations of microbes to synchronize and coordinate gene expression (Miller & Bassler, 2001, Waters & Bassler, 2005). It is well appreciated now that subsequent to the “quorum” formation in *P. aeruginosa*, QS can regulate an arsenal of virulence factors including extracellular as well as cell-surface associated factors thereby impacting *P. aeruginosa* host pathogenesis and clinical outcomes. A few of them include the production of secreted factors such as proteases, elastases, rhamnolipids, phenazine compounds like pyocyanin and siderophores such as pyoverdine and pyochelin (Latifi, *et al.*, 1995, Pearson, *et al.*, 1997, Reimann, *et al.*, 1997). *P. aeruginosa* motility such as swarming phenotype as well as biofilm formation has also been linked to quorum sensing.

Herbal medicines have always been a source of many antibiotics. In recent years however, they have been mined for their anti-QS properties (Panda, *et al.*, 2016). Previous literature and experiments in the lab have shown that *Panax ginseng*, a Chinese herb does not alter *P. aeruginosa* bacterial growth but rather suppressed the production of LasA, LasB, down-regulated the synthesis of AHL molecules, reduced swarming motility, inhibited biofilm formation, and dispersed preformed biofilms (Song, *et al.*, 2010, Wu, *et al.*, 2011). Major components of *Panax ginseng* are the ginsenosides, among which over 30 have been discovered and extensively studied (Leung & Wong, 2010). Experimental analyses of the ginsenosides exhibited no alteration of quorum-sensing phenotypes (Song, *et al.*, 2010).

Aside from the ginsenosides, aqueous extracts of *P. ginseng* contain many other non-nitrogen and nitrogen-based compounds including organic acids, peptides, amines, nucleic acids and free amino acids (FAA)(Attele, *et al.*, 1999). Studies have shown that the FAA content of *P. ginseng* constitutes about 45% of the total amino acids and that arginine was responsible for about 60% of the total FAA (Kwon, *et al.*, 1990, Park, *et al.*, 1990). In this study, we hypothesize that the high content of free arginine in *P. ginseng* contributes to the anti-QS effects seen in its aqueous extracts. To investigate this, the effects of L-arginine on the quorum sensing phenotypes were analyzed.

MATERIALS AND METHODS

Bacterial strains, growth media and culture conditions. *Pseudomonas aeruginosa* PAO1 (Holloway & Morgan, 1986), PAO Δ retS, PAO Δ algD Δ pel Δ psl, were used for analysis of QS phenotypes. *Staphylococcus aureus* (ATCC 12600) was used for the assay of LasA protease (Kessler, *et al.*, 1993). All bacteria were maintained on Luria broth (LB) and grown overnight at 37 °C. L-arginine (Sigma-Aldrich) dissolved in LB for the assays.

Growth curves. The effect of L-arginine on PAO1 growth was determined by monitoring the O.D.₆₀₀ for 16 hours. Briefly, an overnight culture of PAO1 was spun down. The cells were washed with 0.85% saline to remove spent media and diluted to O.D. 1 in fresh LB. From this, the culture was diluted further to an O.D. of 0.025 in fresh LB media in 48-well plates (Falcon) for monitoring growth. L-arginine at the desired concentrations was added and the absorbance at 600nm was monitored at one-hour intervals using BioTek Synergy HT (Winooski, VT, USA) plate reader for 17 hours at 37 °C.

Swarming assay. The assay was performed on plates containing 0.65% agar with L-arginine at the test concentrations. An overnight culture of PAO1 was diluted to an OD₆₀₀ of 1. One μ L of this culture was spotted onto autoclaved-sterile discs. The plates were placed in a 30°C incubator and the swarming motility was measured every 24 and 48 hours (Henrichsen, 1972, Kohler, *et al.*, 2000).

LasA staphylolytic assay. The LasA protease activity was determined as previously described (Kessler, *et al.*, 1993, Kong, *et al.*, 2005). Briefly, *P. aeruginosa* was grown overnight with and without L-arginine. A 20 μ L of the culture supernatant was added to 180 μ L of boiled *S. aureus*. The lysis of *S. aureus* was monitored every 10 minutes by recording the OD₆₀₀ at 37 °C for an hour. The activity was noted as the decrease in OD₆₀₀ per hour.

LasB elastolytic assay. Elastin Congo red (ECR, Sigma, St. Louis, MO) was used to determine the role of L-arginine in regulating the elastolytic activity of *P. aeruginosa* PAO1 as described before (Ohman, *et al.*, 1980). Briefly, 900 μ L of ECR buffer containing 100 mM Tris, 1 mM CaCl₂, pH 7.6-7.5 was made with 20 mg of ECR and vortexed to dissolve. To this, a 100 μ L aliquot of *P. aeruginosa* supernatants was added. This mixture was incubated with shaking at 37 °C for one hour. Insoluble ECR was removed by centrifugation. Activity was expressed as the change in OD₄₉₅ after one-hour incubation (Nishino & Powers, 1980, Ohman, *et al.*, 1980).

Pyocyanin assay. Overnight cultures of *P. aeruginosa* PAO1 with L-arginine was grown for 18-20 hours to obtain bacteria at stationary phase. The optical densities of all bacteria were normalized before the assay. 5 ml of the supernatant was extracted into a tube containing 3 ml of chloroform and vortexed. This was centrifuged, and the top layer removed. To the bottom layer, 1 ml of 0.2 N HCl was added. This was vortexed and centrifuged. The top (pink) aqueous phase was removed into a cuvette and the absorbance at 520 nm recorded. The absorbance is multiplied by 17.072 indicating the concentration of pyocyanin produced per ml of culture ($\mu\text{g/ml}$) (Kurachi, 1958, Essar, *et al.*, 1990).

Biofilm assay. Biofilm assay was performed in tubes as described previously (Friedman & Kolter, 2004, O'Toole, 2011). Briefly, overnight cultures of PAO1 grown on LB agar plates were resuspended in LB to a final dilution of 0.0025. The test samples contained L-arginine at 25 and 50mM. *PAO Δ retS* and *PAO Δ algD Δ pel Δ psl* were kept as positive and negative controls, respectively (Goodman, *et al.*, 2004). All the tubes were incubated at 37 °C for 24-48 hours. Subsequently, the culture was discarded and the tubes washed in bins containing water and left at room temperature for 10 minutes. This was stained with 0.1% crystal violet. The dye was removed after 20 minutes and the tubes were washed thoroughly with running tap-water. The attached dye was then solubilized with absolute ethanol and biofilm formation was quantified by recording the absorbance at 590 nm.

AHL assay by GC/MS. AHL extraction from PAO1 supernatants was done using previously described protocols (Makemson, *et al.*, 2006). *P. aeruginosa* cultures were

grown for 18-20 hrs and their OD normalized. The cells were spun down and the supernatant was removed in a separate tube and prepared for AHL detection by gas chromatography/mass spectrometry (Cataldi, *et al.*, 2004, Kusar, *et al.*, 2016). Briefly, the supernatant is divided in equal volumes into two separate tubes. One was treated with 20 μ L/mL acetic acid and the other with 10 μ L/mL of 8N NaOH. These samples were both further extracted three times with equal parts of acidified ethyl acetate on a rotating platform at room temperature. The acidic and basic extracts were dehydrated at 35 $^{\circ}$ C until only a pellet is left. These are resuspended in DMSO and concentrated 20-fold before analyses. For mass-spectrometry controls, synthetic samples of *P. aeruginosa* N-butanoyl AHL and N-dodecanoyl AHL (Sigma-Aldrich) at a concentration of 500 ppm were subjected to the same extraction. The analyses were done by GC-QTOF. The instruments used were Agilent GC coupled to a Q-TOF, with a HP-5MS-UI column (30 m x 0.25 mm x 0.25 μ m). Data was acquired over 9.83 min with an initial temperature of 150 $^{\circ}$ C held for 0.5 min, with an increase to a final temperature of 275 $^{\circ}$ C, at 15 $^{\circ}$ C per minute.

RESULTS

L-arginine shows dose-dependent effect on growth. The growth of PAO1 without L-arginine was compared to the growth with 25, 30, 35, 40, 45, and 50mM of L-arginine in the media. On monitoring growth of PAO1 over 15-17 hours, a decreased growth rate was observed with 45 and 50mM of arginine, during the log phase. *P. ginseng* contains very high concentration of L-arginine (80Mm) and our preliminary experiments indicated that anti-QS effects were noticed specifically a higher concentration of L-arginine. Henceforth, experiments were conducted in the presence of two concentrations of L-

arginine, 25 and 50mM. However, all experiments were conducted after cultures reached stationary phase with normalization of OD 600 of all cultures before assay.

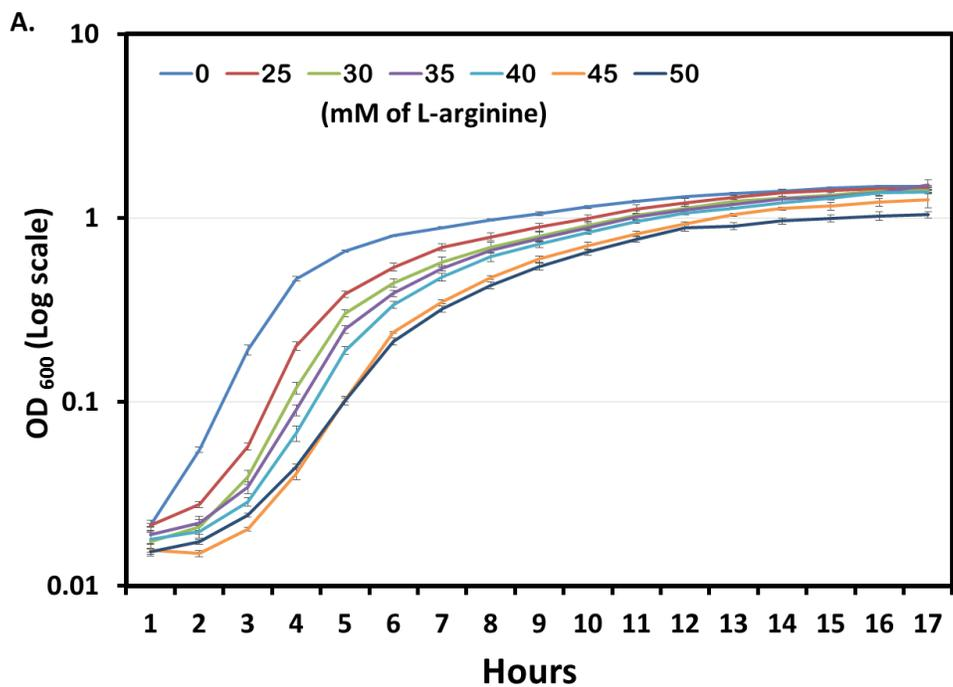

Figure 1. Growth of PAO1 in presence of L- arginine. A. The growth of PAO1 at 0, 25, 30, 35, 40, 45 and 50mM of L-arginine was monitored over 15-17 hours at 37 °C. There was a significant difference in growth between PAO1 (0mM) and PAO1 (45 and 50mM) during log-phase, as determined by unpaired t-test ($p < 0.05$). **B.** The image of the plate after 17 hours of growth is shown. The PAO1 cultures grown with 0, 25 and 50 mM were chosen for further analysis of QS phenotypes. All the cultures were normalized to the same O.D. before continuing the assays.

L-arginine reduces production of LasA protease. *P. aeruginosa* is known to produce a host of secreted virulence factors which includes proteases that are instrumental in establishing acute infections (Schad & Iglewski, 1988). One of these is LasA which is a staphylolytic metalloendopeptidase whose regulation is controlled by QS (Ohman, *et al.*, 1980, Kessler, 1995). Expression of LasA can be analyzed spectrophotometrically by monitoring the change in OD₆₀₀ due to lysis of *S. aureus* (Kessler, *et al.*, 1993, Engel, *et al.*, 1998). The LasA protease activity was quantified in our control which contained supernatant from PAO1 cultures and compared with our testing solutions which had supernatants from PAO1 grown with 25 and 50 mM of L-arginine. Supernatants from PAO1 exposed to L-arginine both at the lower 25mM and the higher concentration of 50 mM showed a dose-dependent decrease in production of this protease, which was not statistically significant (Figure 2).

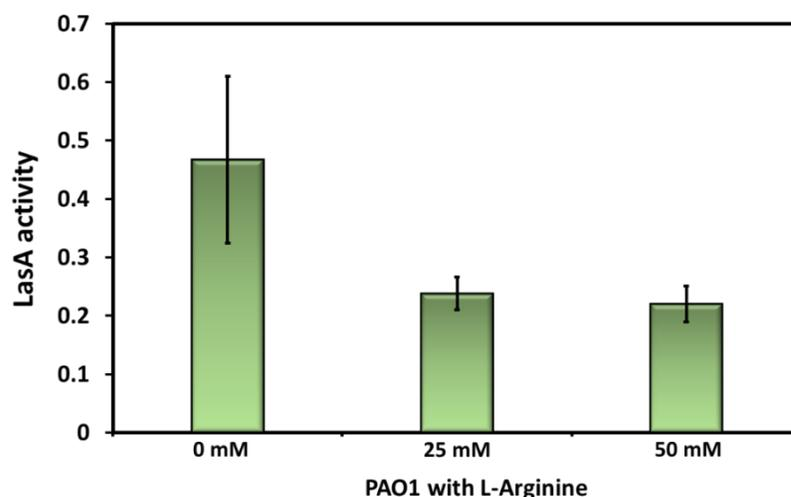

Figure 2. LasA activity in PAO1 supernatants in presence of L-arginine. Las A was quantified as the change in OD₆₀₀ over one hour at 37 °C per µg of protein. The levels of LasA produced by PAO1 in presence of L-arginine were reduced. However, the decrease was not statistically significant ($p > 0.05$) as determined unpaired t-test.

L-arginine reduces production of LasB elastase. The *P. aeruginosa* LasB elastase is also under the control of QS. This protease degrades elastin which is measured using the Elastin Congo Red assay (Ohman, *et al.*, 1980). Under normal circumstances, the supernatant of a *P. aeruginosa* culture degrades elastin leading to an increase in OD₄₉₅. It was found that the production of elastin by *P. aeruginosa* was significantly reduced at the higher concentration of L-arginine of 50 mM, when compared to the supernatant extracted from the strain PAO1 grown without any L-arginine (Figure 3).

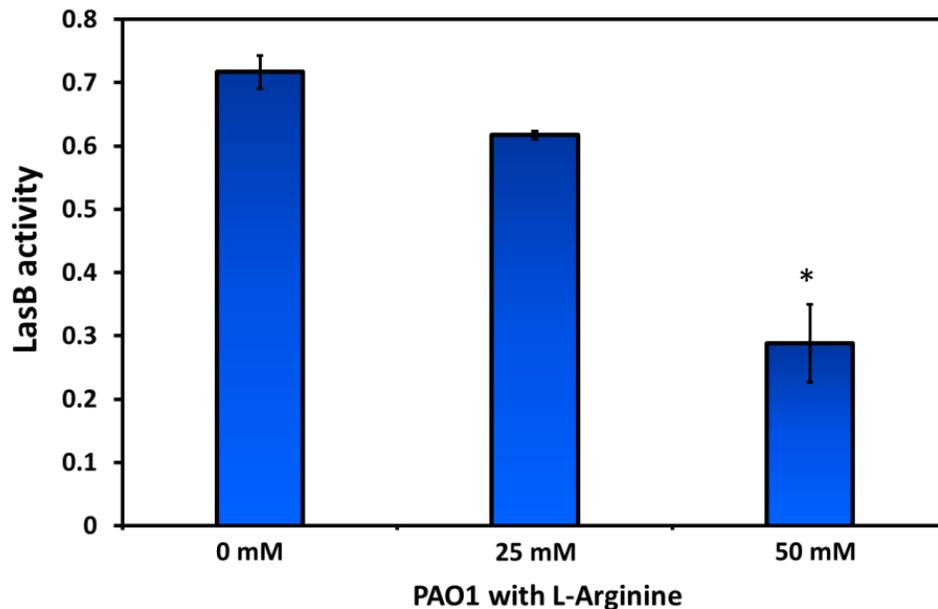

Figure 3. LasB activity in PAO1 supernatants in presence of L-arginine. Elastase activity is expressed as the absorbance at OD₄₉₅ per microgram of protein in PAO1 supernatants. The levels of elastase were decreased significantly in PAO1 with 50mM L-arginine, $p < 0.05$ as determined by unpaired T-test.

L-arginine reduces pyocyanin formation. To further investigate if L-arginine affects the QS-dependent production of pyocyanin. Pyocyanin is one of the redox blue-green pigments produced by Pseudomonads that is frequently associated with acute and chronic infections (Caldwell, *et al.*, 2009). Compared to PAO1 cultured without L-arginine, the pyocyanin produced in the presence of L-arginine was significantly reduced. (Figure 4).

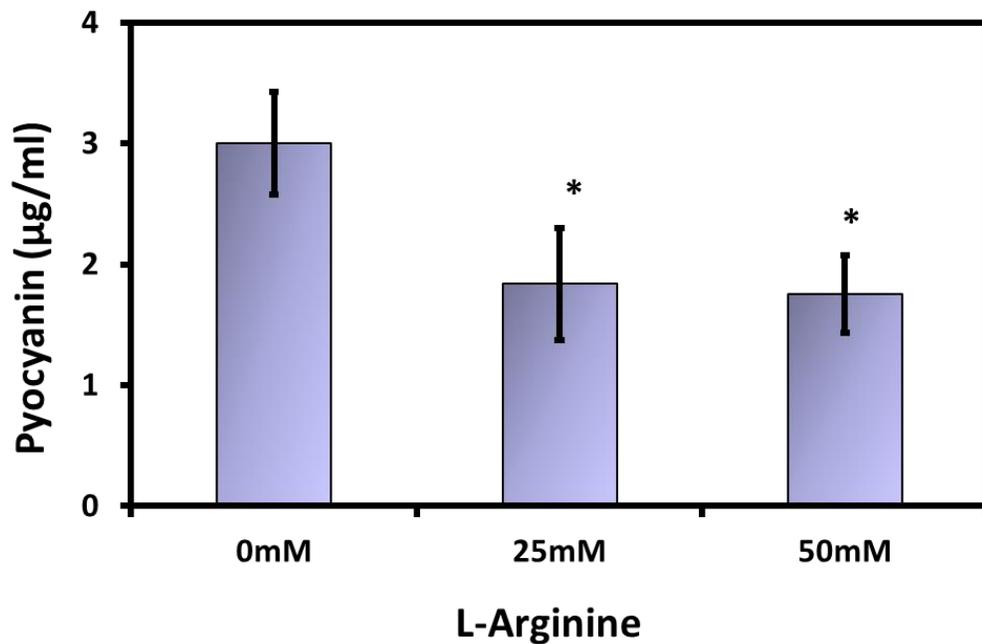

Figure 4. Effect of L-arginine on pyocyanin production. Increasing concentrations of L-arginine led to a decrease in pyocyanin production in PAO1. This decrease was statistically significant at both 25 and 50mM (* $p < 0.05$, 0mM vs 25 mM, 0mM vs 50mM, as determined by unpaired T- test).

L-arginine reduces biofilm formation. Biofilm formation is a chronic-infection phenotype that is in-part regulated by QS (Davies, *et al.*, 1998). Positive control PAO Δ *retS* showed a hyper-biofilm formation whereas negative control PAO Δ *algD* Δ *pel* Δ *psl* showed negligible biofilm as quantified by crystal violet (Figure 5). Presence of L-arginine resulted in a decrease in biofilm formation in a dose-dependent manner.

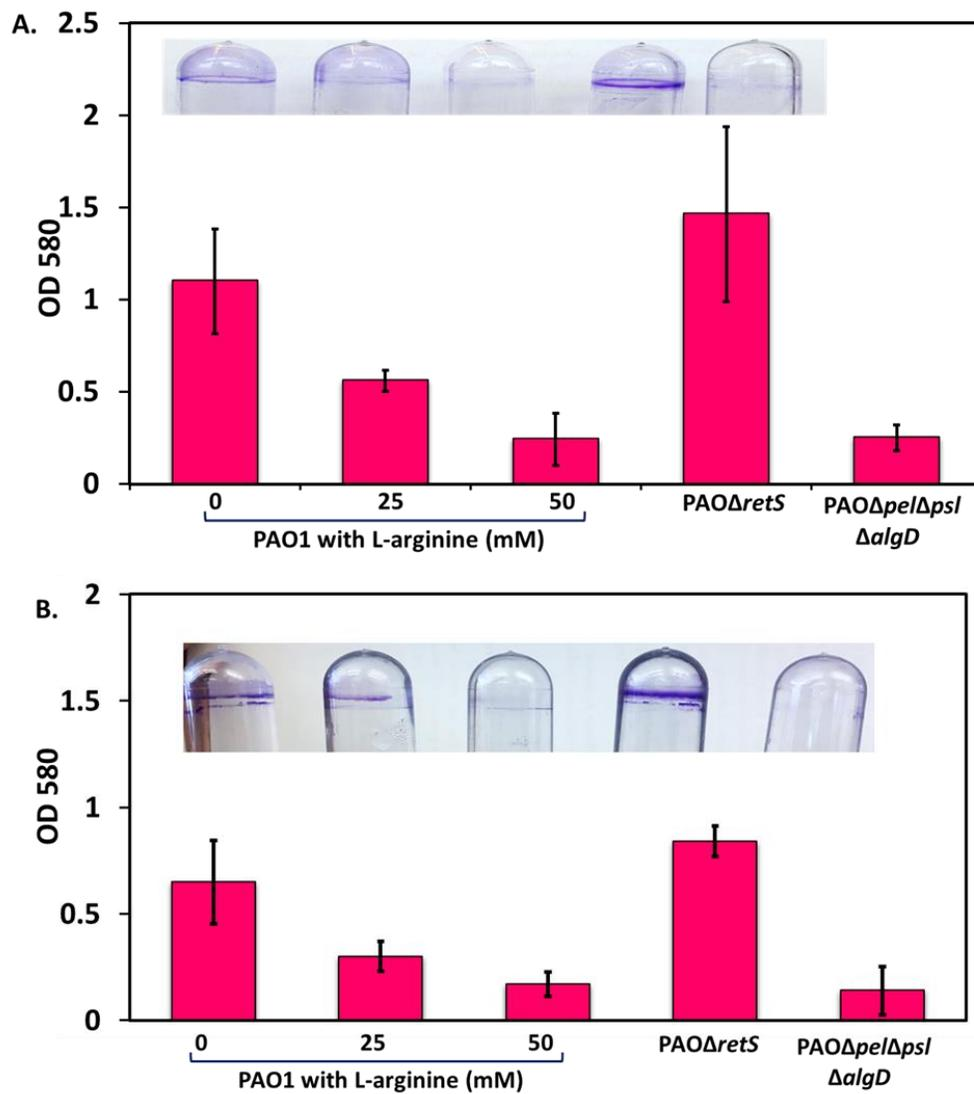

Figure 5. Effect of arginine on biofilm formation. The strains tested were PAO1 in increasing concentrations of L-arginine. As positive control of the assay PAO Δ *retS* which is a biofilm hyperproducer and PAO Δ *algD* Δ *pef* Δ *pil* a non-biofilm producer were also assayed. **A.** After 24 hours, a significant difference (* $p < 0.05$) was observed between PAO1 and PAO1 cultured with 25 and 50 mM of L-arginine, as determined by unpaired t-test. **B.** After 48 hours, a significant difference (* $p < 0.05$) was found between PAO1 with 0 mM of L-arginine and 50mM of L-arginine, as determined by unpaired t-test.

L-arginine reduces production of acyl-homoserine lactone (AHL). Direct identification of AHL was achieved from supernatants by gas-chromatography/mass-spectrometry. For extraction of AHLs, PAO1 supernatants were treated with acid and base, according to previously established protocols (Makemson, *et al.*, 2006). The acid stabilizes the lactone ring whereas the base leads to opening of the lactone ring and destabilizes the signaling molecules. As positive controls for the assay, N-butyryl-L-Homoserine lactone (C4-AHL) and N-(3-Oxododecanoyl)-L-homoserine lactone (C12-AHL) were dissolved in LB and extracted using the same procedure as the test samples. The presence of signaling molecules was also analyzed in LB media, and the supernatants extracted from PAO1 culture with and without L-arginine. It was found that cultures grown with L-arginine at 50 mM reduced the AHL production as seen from the decreased peak intensity (Figure 6).

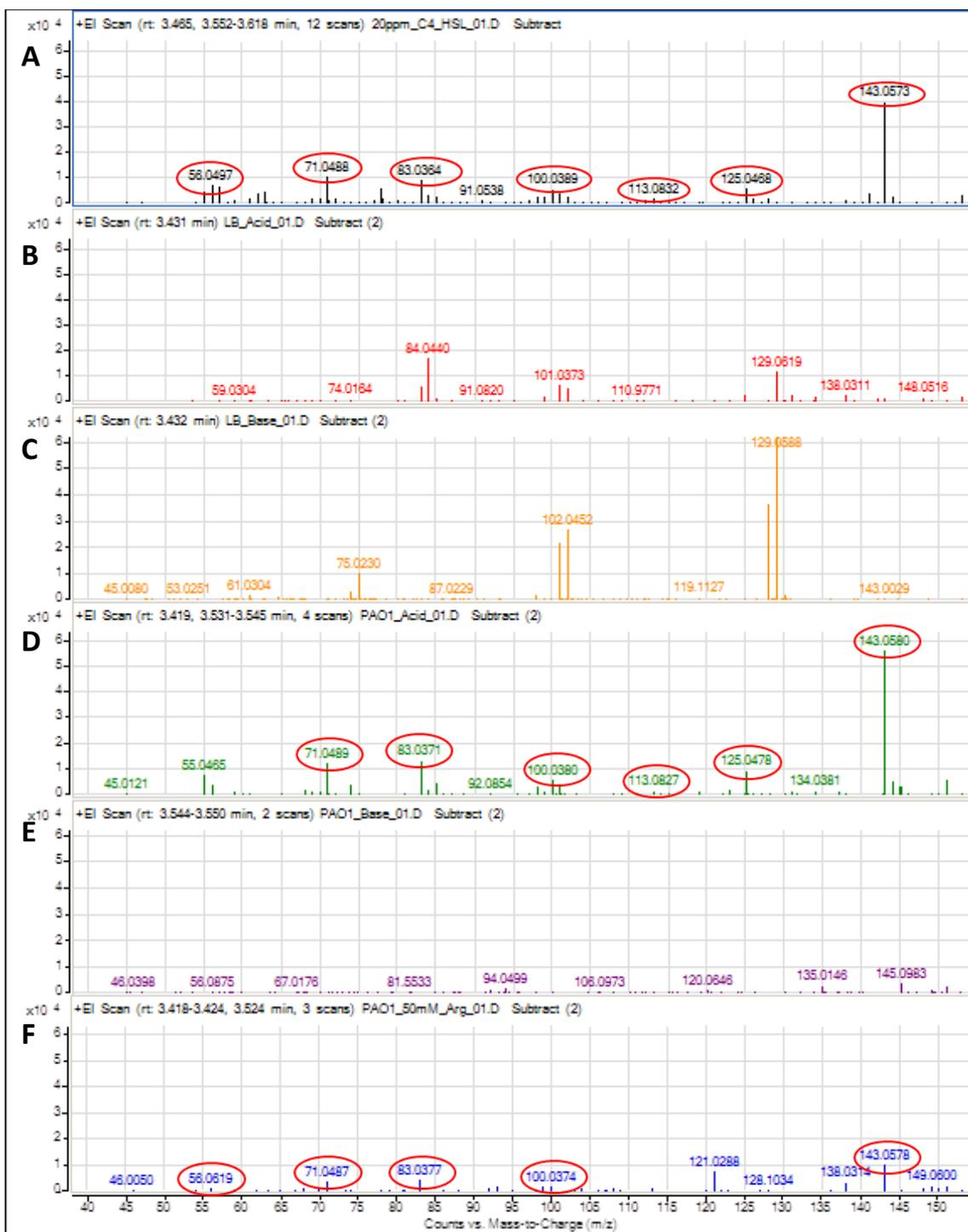

Figure 6. **A.** Panel shows the representative fragmentation spectra of an acyl-homoserine lactone. **B and C.** Panel shows the media control for the experimental samples. LB treated with acid and bases are analyzed for the representative ions. **D.** Supernatant from PAO1 growth culture without arginine in the growth media was treated with acid and examined for fragmentation spectra. The circled ions were found in the culture supernatant indicative of AHL. **E.** Panel shows the same supernatant extracted from PAO1 and treated with base. The alkaline treatment breaks the lactone ring and destabilizes the AHLs. Here this is confirmed as we don't observe any of the ions from the spectra. **F.** Panel shows the supernatant extracted from PAO1 cultured with 50mM L-arginine. As can be observed, the levels of ions were far lower; especially the most abundant ion with m/z 143 was detected at reduced levels.

DISCUSSION

Given the abundance of research that illustrates QS as a critical element of bacterial pathogenesis, it is but natural that identifying anti-QS compounds as alternative/synergistic therapies will be advantageous.

Previous studies in our lab examined herbs with known medicinal properties (Adonizio, *et al.*, 2008, Song, *et al.*, 2010). One of these, *Panax ginseng*, has known immunomodulatory and anti-QS properties (Larsen, *et al.*, 2004, Song, *et al.*, 2010, Wu, *et al.*, 2011, Schneper L., 2012). Experiments with ginsenosides purified from *P. ginseng* did not account for the anti-QS effects (Song, *et al.*, 2010). Besides ginsenosides, *P. ginseng* contains many other bioactive compounds one of which is free amino-acids (Hou, 1977). In this study, the ability of arginine to alter QS was discerned by measuring QS-dependent production of secreted virulence factors such as protease LasA, elastase LasB, and pyocyanin of *P. aeruginosa*. Furthermore, we also determined the effect of arginine on phenotypes critical for host-colonization and sustained infection such as motility and biofilm formation.

Arginine affects the production of QS-regulated virulence factors. The extracellular virulence factors are significant for causing acute infection succeeding colonization. Production of alkaline LasA protease and elastase LasB is determined by the presence of both C-12 and C-4 HSL secreted respectively by the Las and Rhl QS systems (Gambello & Iglewski, 1991, Gambello, *et al.*, 1993, Reimmann, *et al.*, 1997). LasB elastase has immunomodulatory properties and is essential to cleave any elastin containing tissue in a host such as the human lung and is one of the chief components permitting invasive infections (Heck, *et al.*, 1990, Galloway, 1991). LasA is a metallo-endopeptidase which has been implicated as an important virulence factor particularly in corneal infections (Preston, *et al.*, 1997). Along with these proteases, the presence of L-arginine also resulted in decreased production of pyocyanin. Pyocyanin is a blue-green phenazine pigment which is a redox-active compound and facilitates the formation of reactive oxygen stress resulting in tissue injury (Mavrodi, *et al.*, 2001). Previously, it has been shown that extracts of 5% ginseng cause a significant reduction in protease and elastase production. There was, however, a dose-dependent effect wherein the lower concentration of ginseng appeared to increase elastase activity slightly (Song, *et al.*, 2010). In our results, we also witnessed a dose-dependent effect of L-arginine supplementation with increased anti-QS activity observed at higher concentrations (Figure 2, 3, and 5). This decrease in production of virulence was correlated with a decrease in production of HSL molecules as determined by GC/MS in the presence of 50mM L-arginine (Figure 7).

Arginine affects biofilm formation. Previous studies with *P. ginseng* have shown reduced swarming motility and biofilm formation in *P. aeruginosa* PAO1. In our study, we examined the formation of biofilm upto 48 hours. Biofilms are an organized structure

composed of polysaccharides (Pel, Psl, and alginate), extracellular DNA and proteins that encase the bacterial community thereby protecting it from certain host-defenses and antibiotics (Flemming & Wingender, 2010). Biofilm development is a multi-factorial process that depends on swarming and twitching motility and QS (production of C12-HSL by LasI synthase) (O'Toole & Kolter, 1998, Patriquin, *et al.*, 2008). In our study, we saw a progressive decrease of biofilm formation in the presence of increasing concentrations of L-arginine (Figure 5). This decrease could be due to the inhibition of AHL production/transport as well as to the reduced swarming motility that is observed with L-arginine at these concentrations. This is an interesting observation as previous studies done with PA14 which employed a much lower concentration of L-arginine (4.8mM) showed a robust increase in biofilm formation with a reduction in swarming motility owing to modulation of the secondary metabolite c-di-GMP by L-arginine (Bernier, *et al.*, 2011).

In mice burn-wound model, arginine has shown to prevent bacterial dissemination and sepsis (Everett, *et al.*, 2017). Depletion of arginine in burn-wound was associated with increased arginase. Supplementation with L-arginine at concentrations deemed safe for use in humans, post *P. aeruginosa* infection, resulted in the decreased bacterial spread and prolonged animal survival (Everett, *et al.*, 2017). This suggests that arginine may be a valuable alternate therapy for prevention of sepsis in burn-wound patients. The physiologic role of arginine in the human body is well-documented and some mirror the effects of *P. ginseng*, including stimulating the immune system and exhibiting anti-cancer properties (Tong & Barbul, 2004). Consuming L-arginine in doses larger than normal dietary intake has also been linked to improved endothelial dysfunction and overall vascular health (Kamada, *et al.*, 2001). As an anti-*pseudomonal* agent, L-arginine has

shown increased biofilm susceptibility to antibiotics both within mature biofilms and in aerobic/anaerobic conditions (Borriello, *et al.*, 2006). Studies on the effects of inhaled buffered L-arginine in the treatment of CF has shown a significant improvement in thoracic gas volume, arterial PO₂ and specific conductance (Solomons, *et al.*, 1971). Our results also highlight the probability that L-arginine by reducing bacterial virulence may be a beneficial additive or alternate component of combination therapy in *P. aeruginosa* infections.

References

Etymologia: *Pseudomonas* *Emerging Infectious Diseases*. **18**.

Abraham EP & Chain E (1988) An enzyme from bacteria able to destroy penicillin. 1940. *Reviews of infectious diseases* **10**: 677-678.

Acebron I, Mahasenani KV, De Benedetti S, *et al.* (2017) Catalytic cycle of the N-Acetylglucosaminidase NagZ from *Pseudomonas aeruginosa*. *Journal of the American Chemical Society* **139**: 6795-6798.

Adin DM, Engle JT, Goldman WE, McFall-Ngai MJ & Stabb EV (2009) Mutations in *ampG* and lytic transglycosylase genes affect the net release of peptidoglycan monomers from *Vibrio fischeri*. *Journal of bacteriology* **191**: 2012-2022.

Adonizio A, Kong KF & Mathee K (2008) Inhibition of quorum sensing-controlled virulence factor production in *Pseudomonas aeruginosa* by South Florida plant extracts. *Antimicrobial agents and chemotherapy* **52**: 198-203.

Aendekerk S, Ghysels B, Cornelis P & Baysse C (2002) Characterization of a new efflux pump, MexGHI-OpmD, from *Pseudomonas aeruginosa* that confers resistance to vanadium. *Microbiology* **148**: 2371-2381.

Aizawa SI (1996) Flagellar assembly in *Salmonella typhimurium*. *Molecular microbiology* **19**: 1-5.

al-Bar OA, O'Connor CD, Giles IG & Akhtar M (1992) D-alanine: D-alanine ligase of *Escherichia coli*. Expression, purification and inhibitory studies on the cloned enzyme. *The Biochemical journal* **282 (Pt 3)**: 747-752.

Alhede M, Bjarnsholt T, Jensen PO, *et al.* (2009) *Pseudomonas aeruginosa* recognizes and responds aggressively to the presence of polymorphonuclear leukocytes. *Microbiology* **155**: 3500-3508.

Ali L, Goraya MU, Arafat Y, Ajmal M, Chen JL & Yu D (2017) Molecular mechanism of quorum-sensing in *Enterococcus faecalis*: Its role in virulence and therapeutic approaches. *International journal of molecular sciences* **18**.

Allison C & Hughes C (1991) Bacterial swarming: an example of prokaryotic differentiation and multicellular behaviour. *Science progress* **75**: 403-422.

Amanuma H & Strominger JL (1980) Purification and properties of penicillin-binding proteins 5 and 6 from *Escherichia coli* membranes. *The Journal of biological chemistry* **255**: 11173-11180.

Ambler RP (1980) The structure of beta-lactamases. *Philosophical transactions of the Royal Society of London. Series B, Biological sciences* **289**: 321-331.

Amsler K, Santoro C, Foleno B, Bush K & Flamm R (2010) Comparison of broth microdilution, agar dilution, and Etest for susceptibility testing of doripenem against Gram-negative and Gram-positive pathogens. *Journal of clinical microbiology* **48**: 3353-3357.

Anderson JS, Matsushashi M, Haskin MA & Strominger JL (1965) Lipid-phosphoacetylmuramyl-pentapeptide and lipid-phosphodisaccharide-pentapeptide:

presumed membrane transport intermediates in cell wall synthesis. *Proceedings of the National Academy of Sciences of the United States of America* **53**: 881-889.

Angus BL, Carey AM, Caron DA, Kropinski AM & Hancock RE (1982) Outer membrane permeability in *Pseudomonas aeruginosa*: comparison of a wild-type with an antibiotic-supersusceptible mutant. *Antimicrobial agents and chemotherapy* **21**: 299-309.

Apel D & Surette MG (2008) Bringing order to a complex molecular machine: the assembly of the bacterial flagella. *Biochim Biophys Acta* **1778**: 1851-1858.

Arora SK, Ritchings BW, Almira EC, Lory S & Ramphal R (1997) A transcriptional activator, FleQ, regulates mucin adhesion and flagellar gene expression in *Pseudomonas aeruginosa* in a cascade manner. *J Bacteriol* **179**: 5574-5581.

Asgarali A, Stubbs KA, Oliver A, Vocadlo DJ & Mark BL (2009) Inactivation of the glycoside hydrolase NagZ attenuates antipseudomonal beta-lactam resistance in *Pseudomonas aeruginosa*. *Antimicrobial agents and chemotherapy* **53**: 2274-2282.

Asoh S, Matsuzawa H, Ishino F, Strominger JL, Matsuhashi M & Ohta T (1986) Nucleotide sequence of the *pbpA* gene and characteristics of the deduced amino acid sequence of penicillin-binding protein 2 of *Escherichia coli* K12. *European journal of biochemistry* **160**: 231-238.

Attele AS, Wu JA & Yuan CS (1999) Ginseng pharmacology: multiple constituents and multiple actions. *Biochemical pharmacology* **58**: 1685-1693.

Avison MB, Horton RE, Walsh TR & Bennett PM (2001) *Escherichia coli* CreBC is a global regulator of gene expression that responds to growth in minimal media. *The Journal of biological chemistry* **276**: 26955-26961.

Avison MB, Niumsop P, Nurmahomed K, Walsh TR & Bennett PM (2004) Role of the 'cre/blr-tag' DNA sequence in regulation of gene expression by the *Aeromonas hydrophila* beta-lactamase regulator, BlrA. *The Journal of antimicrobial chemotherapy* **53**: 197-202.

Azucena E & Mobashery S (2001) Aminoglycoside-modifying enzymes: mechanisms of catalytic processes and inhibition. *Drug resistance updates : reviews and commentaries in antimicrobial and anticancer chemotherapy* **4**: 106-117.

Azzolina B & El-Sherbeini M (2002) Mray gene and enzyme of *Pseudomonas aeruginosa*. ed.^eds.), p.^pp. Google Patents.

Azzolina BA, Yuan X, Anderson MS & El-Sherbeini M (2001) The cell wall and cell division gene cluster in the Mra operon of *Pseudomonas aeruginosa*: cloning, production, and purification of active enzymes. *Protein expression and purification* **21**: 393-400.

Babouee Flury B, Ellington MJ, Hopkins KL, *et al.* (2016) Association of novel nonsynonymous single nucleotide polymorphisms in *ampD* with cephalosporin resistance and phylogenetic variations in *ampC*, *ampR*, *ompF*, and *ompC* in *Enterobacter cloacae* isolates that are highly resistant to carbapenems. *Antimicrobial agents and chemotherapy* **60**: 2383-2390.

Bacik JP, Whitworth GE, Stubbs KA, *et al.* (2011) Molecular basis of 1,6-anhydro bond cleavage and phosphoryl transfer by *Pseudomonas aeruginosa* 1,6-anhydro-N-acetylmuramic acid kinase. *The Journal of biological chemistry* **286**: 12283-12291.

- Backhed F, Normark S, Schweda EK, Oscarson S & Richter-Dahlfors A (2003) Structural requirements for TLR4-mediated LPS signalling: a biological role for LPS modifications. *Microbes and infection* **5**: 1057-1063.
- Bader MS, Loeb M & Brooks AA (2017) An update on the management of urinary tract infections in the era of antimicrobial resistance. *Postgraduate medicine* **129**: 242-258.
- Badet B, Vermoote P, Haumont PY, Lederer F & LeGoffic F (1987) Glucosamine synthetase from *Escherichia coli*: purification, properties, and glutamine-utilizing site location. *Biochemistry* **26**: 1940-1948.
- Balasubramanian D, Kumari H & Mathee K (2015) *Pseudomonas aeruginosa* AmpR: an acute-chronic switch regulator. *Pathogens and disease* **73**: 1-14.
- Balasubramanian D, Schneper L, Kumari H & Mathee K (2013) A dynamic and intricate regulatory network determines *Pseudomonas aeruginosa* virulence. *Nucleic acids research* **41**: 1-20.
- Balasubramanian D, Schneper L, Merighi M, Smith R, Narasimhan G, Lory S & Mathee K (2012) The regulatory repertoire of *Pseudomonas aeruginosa* AmpC beta-lactamase regulator AmpR includes virulence genes. *PloS one* **7**: e34067.
- Balasubramanian D, Kumari H, Jaric M, *et al.* (2014) Deep sequencing analyses expands the *Pseudomonas aeruginosa* AmpR regulon to include small RNA-mediated regulation of iron acquisition, heat shock and oxidative stress response. *Nucleic acids research* **42**: 979-998.
- Balcewich MD, Stubbs KA, He Y, James TW, Davies GJ, Vocadlo DJ & Mark BL (2009) Insight into a strategy for attenuating AmpC-mediated beta-lactam resistance: structural basis for selective inhibition of the glycoside hydrolase NagZ. *Protein science : a publication of the Protein Society* **18**: 1541-1551.
- Baquero MR, Bouzon M, Quintela JC, Ayala JA & Moreno F (1996) *dacD*, an *Escherichia coli* gene encoding a novel penicillin-binding protein (PBP6b) with DD-carboxypeptidase activity. *Journal of bacteriology* **178**: 7106-7111.
- Barreteau H, Kovac A, Boniface A, Sova M, Gobec S & Blanot D (2008) Cytoplasmic steps of peptidoglycan biosynthesis. *FEMS microbiology reviews* **32**: 168-207.
- Bartowsky E & Normark S (1993) Interactions of wild-type and mutant AmpR of *Citrobacter freundii* with target DNA. *Molecular microbiology* **10**: 555-565.
- Bassler BL, Greenberg EP & Stevens AM (1997) Cross-species induction of luminescence in the quorum-sensing bacterium *Vibrio harveyi*. *Journal of bacteriology* **179**: 4043-4045.
- Bauernfeind A, Stemplinger I, Jungwirth R & Giamarellou H (1996) Characterization of the plasmidic beta-lactamase CMY-2, which is responsible for cephamycin resistance. *Antimicrobial agents and chemotherapy* **40**: 221-224.
- Bayer AS, Speert DP, Park S, Tu J, Witt M, Nast CC & Norman DC (1991) Functional role of mucoid exopolysaccharide (alginate) in antibiotic-induced and polymorphonuclear leukocyte-mediated killing of *Pseudomonas aeruginosa*. *Infection and immunity* **59**: 302-308.

- Becher A & Schweizer HP (2000) Integration-proficient *Pseudomonas aeruginosa* vectors for isolation of single-copy chromosomal *lacZ* and *lux* gene fusions. *BioTechniques* **29**: 948-950, 952.
- Beck BD & Park JT (1976) Activity of three murein hydrolases during the cell division cycle of *Escherichia coli* K-12 as measured in toluene-treated cells. *Journal of bacteriology* **126**: 1250-1260.
- Benson TE, Marquardt JL, Marquardt AC, Etkorn FA & Walsh CT (1993) Overexpression, purification, and mechanistic study of UDP-N-acetylenolpyruvylglucosamine reductase. *Biochemistry* **32**: 2024-2030.
- Bernier SP, Ha DG, Khan W, Merritt JH & O'Toole GA (2011) Modulation of *Pseudomonas aeruginosa* surface-associated group behaviors by individual amino acids through c-di-GMP signaling. *Research in microbiology* **162**: 680-688.
- Bjarnsholt T (2013) The role of bacterial biofilms in chronic infections. *APMIS. Supplementum* 1-51.
- Blackburn NT & Clarke AJ (2001) Identification of four families of peptidoglycan lytic transglycosylases. *Journal of molecular evolution* **52**: 78-84.
- Blackburn NT & Clarke AJ (2002) Characterization of soluble and membrane-bound family 3 lytic transglycosylases from *Pseudomonas aeruginosa*. *Biochemistry* **41**: 1001-1013.
- Blair JM & Piddock LJ (2009) Structure, function and inhibition of RND efflux pumps in Gram-negative bacteria: an update. *Current opinion in microbiology* **12**: 512-519.
- Bodey GP, Bolivar R, Fainstein V & Jadeja L (1983) Infections caused by *Pseudomonas aeruginosa*. *Reviews of infectious diseases* **5**: 279-313.
- Boothby D, Daneo-Moore L, Higgins ML, Coyette J & Shockman GD (1973) Turnover of bacterial cell wall peptidoglycans. *The Journal of biological chemistry* **248**: 2161-2169.
- Borisova M, Gisin J & Mayer C (2014) Blocking peptidoglycan recycling in *Pseudomonas aeruginosa* attenuates intrinsic resistance to fosfomycin. *Microbial drug resistance* **20**: 231-237.
- Borisova M, Gisin J & Mayer C (2017) The N-acetylmuramic acid 6-phosphate phosphatase MupP completes the *Pseudomonas* peptidoglycan recycling pathway leading to intrinsic fosfomycin resistance. *mBio* **8**.
- Borisova M, Gaupp R, Duckworth A, *et al.* (2016) Peptidoglycan recycling in Gram-Positive bacteria is crucial for survival in stationary phase. *mBio* **7**.
- Borriello G, Richards L, Ehrlich GD & Stewart PS (2006) Arginine or nitrate enhances antibiotic susceptibility of *Pseudomonas aeruginosa* in biofilms. *Antimicrobial agents and chemotherapy* **50**: 382-384.
- Boudreau MA, Fisher JF & Mobashery S (2012) Messenger functions of the bacterial cell wall-derived muropeptides. *Biochemistry* **51**: 2974-2990.
- Bouhss A, Crouvoisier M, Blanot D & Mengin-Lecreulx D (2004) Purification and characterization of the bacterial MraY translocase catalyzing the first membrane step of peptidoglycan biosynthesis. *The Journal of biological chemistry* **279**: 29974-29980.

- Bouthors AT, Dagoneau-Blanchard N, Naas T, Nordmann P, Jarlier V & Sougakoff W (1998) Role of residues 104, 164, 166, 238 and 240 in the substrate profile of PER-1 beta-lactamase hydrolysing third-generation cephalosporins. *The Biochemical journal* **330 (Pt 3)**: 1443-1449.
- Bouza E, Burillo A & Munoz P (2002) Catheter-related infections: diagnosis and intravascular treatment. *Clinical microbiology and infection : the official publication of the European Society of Clinical Microbiology and Infectious Diseases* **8**: 265-274.
- Boyer S, Faure K, Ader F, et al. (2005) Chronic pneumonia with *Pseudomonas aeruginosa* and impaired alveolar fluid clearance. *Respiratory research* **6**: 17.
- Bradley DE (1980) A function of *Pseudomonas aeruginosa* PAO polar pili: twitching motility. *Canadian journal of microbiology* **26**: 146-154.
- Branda SS, Vik S, Friedman L & Kolter R (2005) Biofilms: the matrix revisited. *Trends in microbiology* **13**: 20-26.
- Braun V & Rehn K (1969) Chemical characterization, spatial distribution and function of a lipoprotein (murein-lipoprotein) of the *E. coli* cell wall. The specific effect of trypsin on the membrane structure. *European journal of biochemistry / FEBS* **10**: 426-438.
- Braun V & Sieglin U (1970) The covalent murein-lipoprotein structure of the *Escherichia coli* cell wall. The attachment site of the lipoprotein on the murein. *European journal of biochemistry / FEBS* **13**: 336-346.
- Breidenstein EB, de la Fuente-Nunez C & Hancock RE (2011) *Pseudomonas aeruginosa*: all roads lead to resistance. *Trends in microbiology* **19**: 419-426.
- Brenner S (1974) The genetics of *Caenorhabditis elegans*. *Genetics* **77**: 71-94.
- Brizio A, Conceicao T, Pimentel M, Da Silva G & Duarte A (2006) High-level expression of IMP-5 carbapenemase owing to point mutation in the -35 promoter region of class 1 integron among *Pseudomonas aeruginosa* clinical isolates. *International journal of antimicrobial agents* **27**: 27-31.
- Brown K, Vial SC, Dedi N, et al. (2013) Crystal structure of the *Pseudomonas aeruginosa* MurG: UDP-GlcNAc substrate complex. *Protein and peptide letters* **20**: 1002-1008.
- Brown SP, West SA, Diggle SP & Griffin AS (2009) Social evolution in micro-organisms and a Trojan horse approach to medical intervention strategies. *Philosophical transactions of the Royal Society of London. Series B, Biological sciences* **364**: 3157-3168.
- Buist G, Steen A, Kok J & Kuipers OP (2008) LysM, a widely distributed protein motif for binding to (peptido)glycans. *Molecular microbiology* **68**: 838-847.
- Burman LG, Reichler J & Park JT (1983) Evidence for multisite growth of *Escherichia coli* murein involving concomitant endopeptidase and transpeptidase activities. *Journal of bacteriology* **156**: 386-392.
- Bush K (2012) Antimicrobial agents targeting bacterial cell walls and cell membranes. *Revue scientifique et technique* **31**: 43-56.
- Bush K (2013) Introduction to Antimicrobial Therapeutics Reviews: the bacterial cell wall as an antimicrobial target. *Annals of the New York Academy of Sciences* **1277**: v-vii.

- Bush K & Singer SB (1989) Biochemical characteristics of extended broad spectrum beta-lactamases. *Infection* **17**: 429-433.
- Bush K, Jacoby GA & Medeiros AA (1995) A functional classification scheme for beta-lactamases and its correlation with molecular structure. *Antimicrobial agents and chemotherapy* **39**: 1211-1233.
- Bycroft BW & Shute RE (1985) The molecular basis for the mode of action of Beta-lactam antibiotics and mechanisms of resistance. *Pharmaceutical research* **2**: 3-14.
- Cadro D, Horan, T., Andrus, M., Dembinski, M., Edwards, J., Peavy, G., (2004) National Nosocomial Infections Surveillance (NNIS) System Report, data summary from January 1992 through June 2004, issued October 2004. *American journal of infection control* **32**: 470-485.
- Caille O, Zincke D, Merighi M, *et al.* (2014) Structural and functional characterization of *Pseudomonas aeruginosa* global regulator AmpR. *Journal of bacteriology* **196**: 3890-3902.
- Calcagno M, Campos PJ, Mulliert G & Suastegui J (1984) Purification, molecular and kinetic properties of glucosamine-6-phosphate isomerase (deaminase) from *Escherichia coli*. *Biochimica et biophysica acta* **787**: 165-173.
- Caldwell CC, Chen Y, Goetzmann HS, *et al.* (2009) *Pseudomonas aeruginosa* exotoxin pyocyanin causes cystic fibrosis airway pathogenesis. *The American journal of pathology* **175**: 2473-2488.
- Cantarel BL, Coutinho PM, Rancurel C, Bernard T, Lombard V & Henrissat B (2009) The Carbohydrate-Active EnZymes database (CAZy): an expert resource for glycogenomics. *Nucleic acids research* **37**: D233-238.
- Carlson CA & Ingraham JL (1983) Comparison of denitrification by *Pseudomonas stutzeri*, *Pseudomonas aeruginosa*, and *Paracoccus denitrificans*. *Applied and environmental microbiology* **45**: 1247-1253.
- Carlsson M, Shukla S, Petersson AC, Segelmark M & Hellmark T (2011) *Pseudomonas aeruginosa* in cystic fibrosis: pyocyanin negative strains are associated with BPI-ANCA and progressive lung disease. *Journal of cystic fibrosis : official journal of the European Cystic Fibrosis Society* **10**: 265-271.
- Carrasco-Lopez C, Rojas-Altuve A, Zhang W, *et al.* (2011) Crystal structures of bacterial peptidoglycan amidase AmpD and an unprecedented activation mechanism. *The Journal of biological chemistry* **286**: 31714-31722.
- Caselli D, Cesaro S, Ziino O, *et al.* (2010) Multidrug resistant *Pseudomonas aeruginosa* infection in children undergoing chemotherapy and hematopoietic stem cell transplantation. *Haematologica* **95**: 1612-1615.
- Castanheira M, Toleman MA, Jones RN, Schmidt FJ & Walsh TR (2004) Molecular characterization of a beta-lactamase gene, *bla*_{GIM-1}, encoding a new subclass of metallo-beta-lactamase. *Antimicrobial agents and chemotherapy* **48**: 4654-4661.
- Cataldi TR, Bianco G, Frommberger M & Schmitt-Kopplin P (2004) Direct analysis of selected N-acyl-L-homoserine lactones by gas chromatography/mass spectrometry. *Rapid communications in mass spectrometry : RCM* **18**: 1341-1344.

- Cavallari JF, Lamers RP, Scheurwater EM, Matos AL & Burrows LL (2013) Changes to its peptidoglycan-remodeling enzyme repertoire modulate beta-lactam resistance in *Pseudomonas aeruginosa*. *Antimicrobial agents and chemotherapy* **57**: 3078-3084.
- CDC (2013) *Antibiotic Resistance Threats in the United States, 2013*. Vol. 2017 ed. (eds.), p. App. Atlanta: Centers for Disease Control and Prevention; 2013.
- Chahboune A, Decaffmeyer M, Brasseur R & Joris B (2005) Membrane topology of the *Escherichia coli* AmpG permease required for recycling of cell wall anhydromuropeptides and AmpC beta-lactamase induction. *Antimicrobial agents and chemotherapy* **49**: 1145-1149.
- Chaloupka J, Kreckova P & Rihova L (1962) The mucopeptide turnover in the cell walls of growing cultures of *Bacillus megaterium* KM. *Experientia* **18**: 362-363.
- Chamaillard M, Hashimoto M, Horie Y, *et al.* (2003) An essential role for NOD1 in host recognition of bacterial peptidoglycan containing diaminopimelic acid. *Nature immunology* **4**: 702-707.
- Chan JM & Dillard JP (2016) *Neisseria gonorrhoeae* crippled its peptidoglycan fragment permease to facilitate toxic peptidoglycan monomer release. *Journal of bacteriology* **198**: 3029-3040.
- Chatterjee AN & Park JT (1964) Biosynthesis of cell wall mucopeptide by a particulate fraction from *Staphylococcus aureus*. *Proceedings of the National Academy of Sciences of the United States of America* **51**: 9-16.
- Chatterjee N, Chatterjee C, Ghosh S, Mukhopadhyay M, Brahmachari R & Patar K (2016) Pattern of urinary antibiograms in a tertiary care hospital of eastern India. *The Journal of the Association of Physicians of India* **64**: 26-30.
- Chen W, Zhang YM & Davies C (2017) Penicillin-Binding Protein 3 is essential for growth of *Pseudomonas aeruginosa*. *Antimicrobial agents and chemotherapy* **61**.
- Cheng K, Smyth RL, Govan JR, *et al.* (1996) Spread of beta-lactam-resistant *Pseudomonas aeruginosa* in a cystic fibrosis clinic. *Lancet* **348**: 639-642.
- Cheng Q & Park JT (2002) Substrate specificity of the AmpG permease required for recycling of cell wall anhydro-muropeptides. *Journal of bacteriology* **184**: 6434-6436.
- Cheng Q, Li H, Merdek K & Park JT (2000) Molecular characterization of the beta-N-acetylglucosaminidase of *Escherichia coli* and its role in cell wall recycling. *Journal of bacteriology* **182**: 4836-4840.
- Chuanchien R, Narasaki CT & Schweizer HP (2002) The MexJK efflux pump of *Pseudomonas aeruginosa* requires OprM for antibiotic efflux but not for efflux of triclosan. *Journal of bacteriology* **184**: 5036-5044.
- Clarke TB, Kawai F, Park SY, Tame JR, Dowson CG & Roper DI (2009) Mutational analysis of the substrate specificity of *Escherichia coli* penicillin binding protein 4. *Biochemistry* **48**: 2675-2683.
- Collia D, Bannister TD, Tan H, *et al.* (2018) A rapid phenotypic whole-cell screening approach for the identification of small-molecule inhibitors that counter beta-lactamase resistance in *Pseudomonas aeruginosa*. *SLAS discovery : advancing life sciences R & D* **23**: 55-64.

- Cookson BT, Tyler AN & Goldman WE (1989) Primary structure of the peptidoglycan-derived tracheal cytotoxin of *Bordetella pertussis*. *Biochemistry* **28**: 1744-1749.
- Costerton JW, Stewart PS & Greenberg EP (1999) Bacterial biofilms: a common cause of persistent infections. *Science* **284**: 1318-1322.
- Cox CD & Adams P (1985) Siderophore activity of pyoverdinin for *Pseudomonas aeruginosa*. *Infection and immunity* **48**: 130-138.
- Coyne S, Courvalin P & Galimand M (2010) Acquisition of multidrug resistance transposon Tn6061 and IS6100-mediated large chromosomal inversions in *Pseudomonas aeruginosa* clinical isolates. *Microbiology* **156**: 1448-1458.
- Craney A, Hohenauer T, Xu Y, Navani NK, Li Y & Nodwell J (2007) A synthetic *luxCDABE* gene cluster optimized for expression in high-GC bacteria. *Nucleic acids research* **35**: e46.
- Crouch Brewer S, Wunderink RG, Jones CB & Leeper KV, Jr. (1996) Ventilator-associated pneumonia due to *Pseudomonas aeruginosa*. *Chest* **109**: 1019-1029.
- Cunrath O, Gasser V, Hoegy F, Reimann C, Guillon L & Schalk IJ (2015) A cell biological view of the siderophore pyochelin iron uptake pathway in *Pseudomonas aeruginosa*. *Environmental microbiology* **17**: 171-185.
- Dahl U, Jaeger T, Nguyen BT, Sattler JM & Mayer C (2004) Identification of a phosphotransferase system of *Escherichia coli* required for growth on N-acetylmuramic acid. *Journal of bacteriology* **186**: 2385-2392.
- Dale JW & Smith JT (1972) A direct comparison of two unusual R-factor-mediated -lactamases. *The Biochemical journal* **128**: 173-174.
- Dale RM, Schnell G & Wong JP (2004) Therapeutic efficacy of "nubiotics" against burn wound infection by *Pseudomonas aeruginosa*. *Antimicrobial agents and chemotherapy* **48**: 2918-2923.
- Dan S, Shah A, Justo JA, Bookstaver PB, Kohn J, Albrecht H & Al-Hasan MN (2016) Prediction of fluoroquinolone resistance in Gram-negative bacteria causing bloodstream infections. *Antimicrobial agents and chemotherapy* **60**: 2265-2272.
- Danel F, Hall LM, Gur D & Livermore DM (1995) OXA-14, another extended-spectrum variant of OXA-10 (PSE-2) beta-lactamase from *Pseudomonas aeruginosa*. *Antimicrobial agents and chemotherapy* **39**: 1881-1884.
- Danel F, Hall LM, Gur D & Livermore DM (1998) OXA-16, a further extended-spectrum variant of OXA-10 beta-lactamase, from two *Pseudomonas aeruginosa* isolates. *Antimicrobial agents and chemotherapy* **42**: 3117-3122.
- Danel F, Hall LM, Duke B, Gur D & Livermore DM (1999) OXA-17, a further extended-spectrum variant of OXA-10 beta-lactamase, isolated from *Pseudomonas aeruginosa*. *Antimicrobial agents and chemotherapy* **43**: 1362-1366.
- Dart JK & Seal DV (1988) Pathogenesis and therapy of *Pseudomonas aeruginosa* keratitis. *Eye* **2 Suppl**: S46-55.
- Dasgupta N, Wolfgang MC, Goodman AL, Arora SK, Jyot J, Lory S & Ramphal R (2003) A four-tiered transcriptional regulatory circuit controls flagellar biogenesis in *Pseudomonas aeruginosa*. *Mol Microbiol* **50**: 809-824.

- Datta N & Kontomichalou P (1965) Penicillinase synthesis controlled by infectious R factors in *Enterobacteriaceae*. *Nature* **208**: 239-241.
- Davey ME, Caiazza NC & O'Toole GA (2003) Rhamnolipid surfactant production affects biofilm architecture in *Pseudomonas aeruginosa* PAO1. *Journal of bacteriology* **185**: 1027-1036.
- Davies DG, Parsek MR, Pearson JP, Iglewski BH, Costerton JW & Greenberg EP (1998) The involvement of cell-to-cell signals in the development of a bacterial biofilm. *Science* **280**: 295-298.
- Davies J & Davies D (2010) Origins and evolution of antibiotic resistance. *Microbiology and molecular biology reviews* : *MMBR* **74**: 417-433.
- Davies J, Gilbert W & Gorini L (1964) Streptomycin, suppression, and the code. *Proceedings of the National Academy of Sciences of the United States of America* **51**: 883-890.
- Davies JC (2002) *Pseudomonas aeruginosa* in cystic fibrosis: pathogenesis and persistence. *Paediatric respiratory reviews* **3**: 128-134.
- Davies KJ, Lloyd D & Boddy L (1989) The effect of oxygen on denitrification in *Paracoccus denitrificans* and *Pseudomonas aeruginosa*. *Journal of general microbiology* **135**: 2445-2451.
- De Pedro MA, Schwarz, U., Nishimura, Y and Hirota, Y. (1980) On the biological role of penicillin-binding proteins 4 and 5. *FEMS Microbiology Letters* **9**: 219-221.
- Dekimpe V & Deziel E (2009) Revisiting the quorum-sensing hierarchy in *Pseudomonas aeruginosa*: the transcriptional regulator RhIR regulates LasR-specific factors. *Microbiology* **155**: 712-723.
- Denome SA, Elf PK, Henderson TA, Nelson DE & Young KD (1999) *Escherichia coli* mutants lacking all possible combinations of eight penicillin binding proteins: viability, characteristics, and implications for peptidoglycan synthesis. *Journal of bacteriology* **181**: 3981-3993.
- Dhar S, Kumari H, Balasubramanian D & Mathee K (2018) Cell-wall recycling and synthesis in *Escherichia coli* and *Pseudomonas aeruginosa* - their role in the development of resistance. *J Med Microbiol* **67**: 1-21.
- Dietrich LE, Price-Whelan A, Petersen A, Whiteley M & Newman DK (2006) The phenazine pyocyanin is a terminal signalling factor in the quorum sensing network of *Pseudomonas aeruginosa*. *Molecular microbiology* **61**: 1308-1321.
- Dietz H, Pfeifle D & Wiedemann B (1997) The signal molecule for beta-lactamase induction in *Enterobacter cloacae* is the anhydromuramyl-pentapeptide. *Antimicrobial agents and chemotherapy* **41**: 2113-2120.
- Dijkstra AJ & Keck W (1996) Identification of new members of the lytic transglycosylase family in *Haemophilus influenzae* and *Escherichia coli*. *Microbial drug resistance* **2**: 141-145.
- Dik DA, Dominguez-Gil T, Lee M, *et al.* (2017) Muropeptide binding and the X-ray structure of the effector domain of the transcriptional regulator AmpR of *Pseudomonas aeruginosa*. *Journal of the American Chemical Society* **139**: 1448-1451.

- Doern CD (2014) When does 2 plus 2 equal 5? A review of antimicrobial synergy testing. *Journal of clinical microbiology* **52**: 4124-4128.
- Doggett RG, Harrison GM & Wallis ES (1964) Comparison of some properties of *Pseudomonas aeruginosa* isolated from infections in persons with and without cystic fibrosis. *Journal of bacteriology* **87**: 427-431.
- Doyle RJ, Chaloupka J & Vinter V (1988) Turnover of cell walls in microorganisms. *Microbiological reviews* **52**: 554-567.
- Doyle TB, Hawkins AC & McCarter LL (2004) The complex flagellar torque generator of *Pseudomonas aeruginosa*. *Journal of bacteriology* **186**: 6341-6350.
- Driscoll JA, Brody SL & Kollef MH (2007) The epidemiology, pathogenesis and treatment of *Pseudomonas aeruginosa* infections. *Drugs* **67**: 351-368.
- Drlica K & Zhao X (1997) DNA gyrase, topoisomerase IV, and the 4-quinolones. *Microbiology and molecular biology reviews : MMBR* **61**: 377-392.
- Drlica K, Malik M, Kerns RJ & Zhao X (2008) Quinolone-mediated bacterial death. *Antimicrobial agents and chemotherapy* **52**: 385-392.
- Duan K, Dammel C, Stein J, Rabin H & Surette MG (2003) Modulation of *Pseudomonas aeruginosa* gene expression by host microflora through interspecies communication. *Molecular microbiology* **50**: 1477-1491.
- Dufresne J, Vezina G & Levesque RC (1988) Cloning and expression of the imipenem-hydrolyzing beta-lactamase operon from *Pseudomonas maltophilia* in *Escherichia coli*. *Antimicrobial agents and chemotherapy* **32**: 819-826.
- Duncan K, van Heijenoort J & Walsh CT (1990) Purification and characterization of the D-alanyl-D-alanine-adding enzyme from *Escherichia coli*. *Biochemistry* **29**: 2379-2386.
- Eckert C, Lecerf M, Dubost L, Arthur M & Mesnage S (2006) Functional analysis of AtlA, the major N-acetylglucosaminidase of *Enterococcus faecalis*. *Journal of bacteriology* **188**: 8513-8519.
- Eibergen NR, Moore JD, Mattmann ME & Blackwell HE (2015) Potent and selective modulation of the RhlR quorum sensing receptor by using non-native ligands: An emerging target for virulence control in *Pseudomonas aeruginosa*. *Chembiochem : a European journal of chemical biology* **16**: 2348-2356.
- El Zoeiby A, Sanschagrín F, Lamoureux J, Darveau A & Levesque RC (2000) Cloning, over-expression and purification of *Pseudomonas aeruginosa murC* encoding uridine diphosphate N-acetylmuramate: L-alanine ligase. *FEMS microbiology letters* **183**: 281-288.
- El Zoeiby A, Sanschagrín F, Havugimana PC, Garnier A & Levesque RC (2001) In vitro reconstruction of the biosynthetic pathway of peptidoglycan cytoplasmic precursor in *Pseudomonas aeruginosa*. *FEMS microbiology letters* **201**: 229-235.
- Elhenawy W, Davis RM, Fero J, Salama NR, Felman MF & Ruiz N (2016) The O-antigen flippase Wzk can substitute for MurJ in peptidoglycan synthesis in *Helicobacter pylori* and *Escherichia coli*. *PloS one* **11**: e0161587.

- Emerson J, Rosenfeld M, McNamara S, Ramsey B & Gibson RL (2002) *Pseudomonas aeruginosa* and other predictors of mortality and morbidity in young children with cystic fibrosis. *Pediatric pulmonology* **34**: 91-100.
- Eng RH, Bishburg E, Smith SM, Geller H & Kapila R (1986) Bacteremia and fungemia in patients with acquired immune deficiency syndrome. *American journal of clinical pathology* **86**: 105-107.
- Engel H, Smink AJ, van Wijngaarden L & Keck W (1992) Murein-metabolizing enzymes from *Escherichia coli*: existence of a second lytic transglycosylase. *Journal of bacteriology* **174**: 6394-6403.
- Engel LS, Hill JM, Caballero AR, Green LC & O'Callaghan RJ (1998) Protease IV, a unique extracellular protease and virulence factor from *Pseudomonas aeruginosa*. *The Journal of biological chemistry* **273**: 16792-16797.
- Essar DW, Eberly L, Hadero A & Crawford IP (1990) Identification and characterization of genes for a second anthranilate synthase in *Pseudomonas aeruginosa*: interchangeability of the two anthranilate synthases and evolutionary implications. *Journal of bacteriology* **172**: 884-900.
- Estahbanati HK, Kashani PP & Ghanaatpisheh F (2002) Frequency of *Pseudomonas aeruginosa* serotypes in burn wound infections and their resistance to antibiotics. *Burns : journal of the International Society for Burn Injuries* **28**: 340-348.
- EUCAST (2000) EUCAST Definitive Document E.DEF 3.1, June 2000: Determination of minimum inhibitory concentrations (MICs) of antibacterial agents by agar dilution. *Clinical microbiology and infection : the official publication of the European Society of Clinical Microbiology and Infectious Diseases* **6**: 509-515.
- Evans LR & Linker A (1973) Production and characterization of the slime polysaccharide of *Pseudomonas aeruginosa*. *Journal of bacteriology* **116**: 915-924.
- Everett J, Turner K, Cai Q, Gordon V, Whiteley M & Rumbaugh K (2017) Arginine Is a Critical Substrate for the Pathogenesis of *Pseudomonas aeruginosa* in Burn Wound Infections. *mBio* **8**.
- Fairfax MR, Queenan AM, Lephart PR, *et al.* (2011) Detection of 2 SME-1 carbapenemase-producing *Serratia marcescens* in Detroit. *Diagnostic microbiology and infectious disease* **71**: 325-326.
- Fajardo A, Hernando-Amado S, Oliver A, Ball G, Filloux A & Martinez JL (2014) Characterization of a novel Zn(2)(+)-dependent intrinsic imipenemase from *Pseudomonas aeruginosa*. *The Journal of antimicrobial chemotherapy* **69**: 2972-2978.
- Falagas ME & Kasiakou SK (2005) Colistin: the revival of polymyxins for the management of multidrug-resistant Gram-negative bacterial infections. *Clinical infectious diseases : an official publication of the Infectious Diseases Society of America* **40**: 1333-1341.
- Favero MS, Carson LA, Bond WW & Petersen NJ (1971) *Pseudomonas aeruginosa*: growth in distilled water from hospitals. *Science* **173**: 836-838.
- Fein JE (1979) Possible involvement of bacterial autolytic enzymes in flagellar morphogenesis. *Journal of bacteriology* **137**: 933-946.

- Feldman M, Bryan R, Rajan S, Scheffler L, Brunnert S, Tang H & Prince A (1998) Role of flagella in pathogenesis of *Pseudomonas aeruginosa* pulmonary infection. *Infection and immunity* **66**: 43-51.
- Feunou PF, Ismaili J, Debie AS, *et al.* (2008) Genetic stability of the live attenuated *Bordetella pertussis* vaccine candidate BPZE1. *Vaccine* **26**: 5722-5727.
- Figurski DH & Helinski DR (1979) Replication of an origin-containing derivative of plasmid RK2 dependent on a plasmid function provided in trans. *Proc Natl Acad Sci U S A* **76**: 1648-1652.
- Finan TM, Kunkel B, De Vos GF & Signer ER (1986) Second symbiotic megaplasmid in *Rhizobium meliloti* carrying exopolysaccharide and thiamine synthesis genes. *J Bacteriol* **167**: 66-72.
- Finck-Barbancon V, Goranson J, Zhu L, *et al.* (1997) ExoU expression by *Pseudomonas aeruginosa* correlates with acute cytotoxicity and epithelial injury. *Molecular microbiology* **25**: 547-557.
- Finn RD, Coghill P, Eberhardt RY, *et al.* (2016) The Pfam protein families database: towards a more sustainable future. *Nucleic acids research* **44**: D279-285.
- Fisher JF & Mobashery S (2014) The sentinel role of peptidoglycan recycling in the beta-lactam resistance of the Gram-negative Enterobacteriaceae and *Pseudomonas aeruginosa*. *Bioorganic chemistry* **56**: 41-48.
- Fisher JF, Meroueh SO & Mobashery S (2005) Bacterial resistance to beta-lactam antibiotics: compelling opportunism, compelling opportunity. *Chemical reviews* **105**: 395-424.
- Fito-Boncompte L, Chapalain A, Bouffartigues E, *et al.* (2011) Full virulence of *Pseudomonas aeruginosa* requires OprF. *Infection and immunity* **79**: 1176-1186.
- Fleeman R, LaVoi TM, Santos RG, *et al.* (2015) Combinatorial libraries as a tool for the discovery of novel, broad-spectrum antibacterial agents targeting the ESKAPE pathogens. *Journal of medicinal chemistry* **58**: 3340-3355.
- Flemming HC & Wingender J (2010) The biofilm matrix. *Nature reviews. Microbiology* **8**: 623-633.
- Flume PA, Mogayzel PJ, Jr., Robinson KA, Goss CH, Rosenblatt RL, Kuhn RJ & Marshall BC (2009) Cystic fibrosis pulmonary guidelines: treatment of pulmonary exacerbations. *American journal of respiratory and critical care medicine* **180**: 802-808.
- Folkesson A, Eriksson S, Andersson M, Park JT & Normark S (2005) Components of the peptidoglycan-recycling pathway modulate invasion and intracellular survival of *Salmonella enterica* serovar Typhimurium. *Cellular microbiology* **7**: 147-155.
- Fothergill JL, Winstanley C & James CE (2012) Novel therapeutic strategies to counter *Pseudomonas aeruginosa* infections. *Expert review of anti-infective therapy* **10**: 219-235.
- Frank DW (1997) The exoenzyme S regulon of *Pseudomonas aeruginosa*. *Molecular microbiology* **26**: 621-629.
- Freire P, Moreira RN & Arraiano CM (2009) BolA inhibits cell elongation and regulates MreB expression levels. *Journal of molecular biology* **385**: 1345-1351.

- Friedman L & Kolter R (2004) Genes involved in matrix formation in *Pseudomonas aeruginosa* PA14 biofilms. *Molecular microbiology* **51**: 675-690.
- Fujimoto Y & Fukase K (2011) Structures, synthesis, and human Nod1 stimulation of immunostimulatory bacterial peptidoglycan fragments in the environment. *Journal of natural products* **74**: 518-525.
- Fumeaux C & Bernhardt TG (2017) Identification of MupP as a new peptidoglycan recycling factor and antibiotic resistance determinant in *Pseudomonas aeruginosa*. *mBio* **8**.
- Furste JP, Pansegrau W, Frank R, Blocker H, Scholz P, Bagdasarian M & Lanka E (1986) Molecular cloning of the plasmid RP4 primase region in a multi-host-range *tacP* expression vector. *Gene* **48**: 119-131.
- Furukawa S, Kuchma SL & O'Toole GA (2006) Keeping their options open: acute versus persistent infections. *Journal of bacteriology* **188**: 1211-1217.
- Galloway DR (1991) *Pseudomonas aeruginosa* elastase and elastolysis revisited: recent developments. *Molecular microbiology* **5**: 2315-2321.
- Gambello MJ & Iglewski BH (1991) Cloning and characterization of the *Pseudomonas aeruginosa lasR* gene, a transcriptional activator of elastase expression. *Journal of bacteriology* **173**: 3000-3009.
- Gambello MJ, Kaye S & Iglewski BH (1993) LasR of *Pseudomonas aeruginosa* is a transcriptional activator of the alkaline protease gene (*apr*) and an enhancer of exotoxin A expression. *Infection and immunity* **61**: 1180-1184.
- Garau J & Gomez L (2003) *Pseudomonas aeruginosa* pneumonia. *Current opinion in infectious diseases* **16**: 135-143.
- Garcia DL & Dillard JP (2008) Mutations in *ampG* or *ampD* affect peptidoglycan fragment release from *Neisseria gonorrhoeae*. *Journal of bacteriology* **190**: 3799-3807.
- Gaynes R & Edwards JR (2005) Overview of nosocomial infections caused by Gram-negative bacilli. *Clinical infectious diseases : an official publication of the Infectious Diseases Society of America* **41**: 848-854.
- Gellatly SL & Hancock RE (2013) *Pseudomonas aeruginosa*: new insights into pathogenesis and host defenses. *Pathogens and disease* **67**: 159-173.
- Gibson DG, Young L, Chuang RY, Venter JC, Hutchison CA, 3rd & Smith HO (2009) Enzymatic assembly of DNA molecules up to several hundred kilobases. *Nat Methods* **6**: 343-345.
- Girardin SE, Travassos LH, Herve M, *et al.* (2003) Peptidoglycan molecular requirements allowing detection by Nod1 and Nod2. *The Journal of biological chemistry* **278**: 41702-41708.
- Girlich D, Naas T & Nordmann P (2004) Biochemical characterization of the naturally occurring oxacillinase OXA-50 of *Pseudomonas aeruginosa*. *Antimicrobial agents and chemotherapy* **48**: 2043-2048.
- Gisin J, Schneider A, Nagele B, Borisova M & Mayer C (2013) A cell wall recycling shortcut that bypasses peptidoglycan de novo biosynthesis. *Nature chemical biology* **9**: 491-493.

- Glauner B (1988) Separation and quantification of muropeptides with high-performance liquid chromatography. *Analytical biochemistry* **172**: 451-464.
- Glauner B, Holtje JV & Schwarz U (1988) The composition of the murein of *Escherichia coli*. *The Journal of biological chemistry* **263**: 10088-10095.
- Godfrey AJ, Bryan LE & Rabin HR (1981) beta-Lactam-resistant *Pseudomonas aeruginosa* with modified penicillin-binding proteins emerging during cystic fibrosis treatment. *Antimicrobial agents and chemotherapy* **19**: 705-711.
- Goffin C & Ghuyssen JM (1998) Multimodular penicillin-binding proteins: an enigmatic family of orthologs and paralogs. *Microbiology and molecular biology reviews : MMBR* **62**: 1079-1093.
- Goldman WE & Herwaldt LA (1985) *Bordetella pertussis* tracheal cytotoxin. *Developments in biological standardization* **61**: 103-111.
- Goldman WE & Cookson BT (1988) Structure and functions of the *Bordetella* tracheal cytotoxin. *The Tokai journal of experimental and clinical medicine* **13 Suppl**: 187-191.
- Goodell EW (1985) Recycling of murein by *Escherichia coli*. *Journal of bacteriology* **163**: 305-310.
- Goodell EW & Schwarz U (1985) Release of cell wall peptides into culture medium by exponentially growing *Escherichia coli*. *Journal of bacteriology* **162**: 391-397.
- Goodell EW & Higgins CF (1987) Uptake of cell wall peptides by *Salmonella typhimurium* and *Escherichia coli*. *Journal of bacteriology* **169**: 3861-3865.
- Goodman AL, Kulasekara B, Rietsch A, Boyd D, Smith RS & Lory S (2004) A signaling network reciprocally regulates genes associated with acute infection and chronic persistence in *Pseudomonas aeruginosa*. *Developmental cell* **7**: 745-754.
- Goodman AL, Merighi M, Hyodo M, Ventre I, Filloux A & Lory S (2009) Direct interaction between sensor kinase proteins mediates acute and chronic disease phenotypes in a bacterial pathogen. *Genes & development* **23**: 249-259.
- Gotoh N, Wakebe H & Nishino T (1989) Ultrastructural aspects of fragility of *Pseudomonas aeruginosa* outer membrane devoid of protein F. *FEMS microbiology letters* **50**: 51-53.
- Gotoh N, Tsujimoto H, Tsuda M, *et al.* (1998) Characterization of the MexC-MexD-OprJ multidrug efflux system in *Delta mexA-mexB-oprM* mutants of *Pseudomonas aeruginosa*. *Antimicrobial agents and chemotherapy* **42**: 1938-1943.
- Govan JR & Harris GS (1986) *Pseudomonas aeruginosa* and cystic fibrosis: unusual bacterial adaptation and pathogenesis. *Microbiological sciences* **3**: 302-308.
- Guinote IB, Matos RG, Freire P & Arraiano CM (2011) BolA affects cell growth, and binds to the promoters of penicillin-binding proteins 5 and 6 and regulates their expression. *Journal of microbiology and biotechnology* **21**: 243-251.
- Gupta SK, Berk RS, Masinick S & Hazlett LD (1994) Pili and lipopolysaccharide of *Pseudomonas aeruginosa* bind to the glycolipid asialo GM1. *Infection and immunity* **62**: 4572-4579.

- Hancock RE (1998) Resistance mechanisms in *Pseudomonas aeruginosa* and other nonfermentative gram-negative bacteria. *Clinical infectious diseases : an official publication of the Infectious Diseases Society of America* **27 Suppl 1**: S93-99.
- Hancock RE, Decad GM & Nikaido H (1979) Identification of the protein producing transmembrane diffusion pores in the outer membrane of *Pseudomonas aeruginosa* PAO1. *Biochimica et biophysica acta* **554**: 323-331.
- Handfield J, Gagnon L, Dargis M & Huletsky A (1997) Sequence of the *ponA* gene and characterization of the penicillin-binding protein 1A of *Pseudomonas aeruginosa* PAO1. *Gene* **199**: 49-56.
- Hashimoto W, Ochiai A, Momma K, Itoh T, Mikami B, Maruyama Y & Murata K (2009) Crystal structure of the glycosidase family 73 peptidoglycan hydrolase FlgJ. *Biochemical and biophysical research communications* **381**: 16-21.
- Hassan MT, van der Lelie D, Springael D, Romling U, Ahmed N & Mergeay M (1999) Identification of a gene cluster, *czr*, involved in cadmium and zinc resistance in *Pseudomonas aeruginosa*. *Gene* **238**: 417-425.
- Hassett DJ, Charniga L, Bean K, Ohman DE & Cohen MS (1992) Response of *Pseudomonas aeruginosa* to pyocyanin: mechanisms of resistance, antioxidant defenses, and demonstration of a manganese-cofactored superoxide dismutase. *Infection and immunity* **60**: 328-336.
- Hauser AR (2009) The type III secretion system of *Pseudomonas aeruginosa*: infection by injection. *Nature reviews. Microbiology* **7**: 654-665.
- Heck LW, Alarcon PG, Kulhavy RM, Morihara K, Russell MW & Mestecky JF (1990) Degradation of IgA proteins by *Pseudomonas aeruginosa* elastase. *Journal of immunology* **144**: 2253-2257.
- Heidrich C, Ursinus A, Berger J, Schwarz H & Holtje JV (2002) Effects of multiple deletions of murein hydrolases on viability, septum cleavage, and sensitivity to large toxic molecules in *Escherichia coli*. *Journal of bacteriology* **184**: 6093-6099.
- Heidrich C, Templin MF, Ursinus A, *et al.* (2001) Involvement of N-acetylmuramyl-L-alanine amidases in cell separation and antibiotic-induced autolysis of *Escherichia coli*. *Molecular microbiology* **41**: 167-178.
- Heilmann HD (1972) On the peptidoglycan of the cell walls of *Pseudomonas aeruginosa*. *European journal of biochemistry* **31**: 456-463.
- Heilmann HD (1974) On the peptidoglycan of the cell walls of *Pseudomonas aeruginosa*. Structure of the peptide side chains. *European journal of biochemistry* **43**: 35-38.
- Heimer SR, Evans DJ, Stern ME, Barbieri JT, Yahr T & Fleiszig SM (2013) *Pseudomonas aeruginosa* utilizes the type III secreted toxin ExoS to avoid acidified compartments within epithelial cells. *PLoS one* **8**: e73111.
- Henderson TA, Templin M & Young KD (1995) Identification and cloning of the gene encoding penicillin-binding protein 7 of *Escherichia coli*. *Journal of bacteriology* **177**: 2074-2079.
- Henrichsen J (1972) Bacterial surface translocation: a survey and a classification. *Bacteriological reviews* **36**: 478-503.

- Herlihey FA, Moynihan PJ & Clarke AJ (2014) The essential protein for bacterial flagella formation FlgJ functions as a beta-N-acetylglucosaminidase. *The Journal of biological chemistry* **289**: 31029-31042.
- Hernandez A, Sanchez MB & Martinez JL (2011) Quinolone resistance: much more than predicted. *Frontiers in microbiology* **2**: 22.
- Herve M, Boniface A, Gobec S, Blanot D & Mengin-Lecreulx D (2007) Biochemical characterization and physiological properties of *Escherichia coli* UDP-N-acetylmuramate:L-alanyl-gamma-D-glutamyl-meso-diaminopimelate ligase. *Journal of bacteriology* **189**: 3987-3995.
- Hesek D, Lee M, Zhang W, Noll BC & Mobashery S (2009) Total synthesis of N-acetylglucosamine-1,6-anhydro-N-acetylmuramylpentapeptide and evaluation of its turnover by AmpD from *Escherichia coli*. *Journal of the American Chemical Society* **131**: 5187-5193.
- Hirano T, Minamino T & Macnab RM (2001) The role in flagellar rod assembly of the N-terminal domain of *Salmonella* FlgJ, a flagellum-specific muramidase. *J Mol Biol* **312**: 359-369.
- Hoang TT, Karkhoff-Schweizer RR, Kutchma AJ & Schweizer HP (1998) A broad-host-range Flp-FRT recombination system for site-specific excision of chromosomally-located DNA sequences: application for isolation of unmarked *Pseudomonas aeruginosa* mutants. *Gene* **212**: 77-86.
- Hobden JA (2002) *Pseudomonas aeruginosa* proteases and corneal virulence. *DNA and cell biology* **21**: 391-396.
- Hoiby N (1974) *Pseudomonas aeruginosa* infection in cystic fibrosis. Relationship between mucoid strains of *Pseudomonas aeruginosa* and the humoral immune response. *Acta pathologica et microbiologica Scandinavica. Section B: Microbiology and immunology* **82**: 551-558.
- Holloway BW (1955) Genetic recombination in *Pseudomonas aeruginosa*. *Journal of general microbiology* **13**: 572-581.
- Holloway BW & Morgan AF (1986) Genome organization in *Pseudomonas*. *Annual review of microbiology* **40**: 79-105.
- Holloway BW, Krishnapillai V & Morgan AF (1979) Chromosomal genetics of *Pseudomonas*. *Microbiological reviews* **43**: 73-102.
- Holtje JV (1998) Growth of the stress-bearing and shape-maintaining murein sacculus of *Escherichia coli*. *Microbiology and molecular biology reviews : MMBR* **62**: 181-203.
- Holtje JV, Mirelman D, Sharon N & Schwarz U (1975) Novel type of murein transglycosylase in *Escherichia coli*. *Journal of bacteriology* **124**: 1067-1076.
- Holtje JV, Kopp U, Ursinus A & Wiedemann B (1994) The negative regulator of beta-lactamase induction AmpD is a N-acetyl-anhydromuramyl-L-alanine amidase. *FEMS microbiology letters* **122**: 159-164.
- Honore N, Nicolas MH & Cole ST (1989) Regulation of enterobacterial cephalosporinase production: the role of a membrane-bound sensory transducer. *Molecular microbiology* **3**: 1121-1130.

- Hooper DC & Jacoby GA (2015) Mechanisms of drug resistance: quinolone resistance. *Annals of the New York Academy of Sciences* **1354**: 12-31.
- Horsch M, Hoesch L, Vasella A & Rast DM (1991) N-acetylglucosaminono-1,5-lactone oxime and the corresponding (phenylcarbamoyl)oxime. Novel and potent inhibitors of beta-N-acetylglucosaminidase. *European journal of biochemistry* **197**: 815-818.
- Hou JP (1977) The chemical constituents of ginseng plants. *Comparative medicine East and West* **5**: 123-145.
- Hrebenda J (1979) Mutants of *Escherichia coli* with altered level of beta-N-acetylglucosaminidase activities. *Acta microbiologica Polonica* **28**: 53-62.
- Huang YW, Lin CW, Hu RM, Lin YT, Chung TC & Yang TC (2010) AmpN-AmpG operon is essential for expression of L1 and L2 beta-lactamases in *Stenotrophomonas maltophilia*. *Antimicrobial agents and chemotherapy* **54**: 2583-2589.
- Humphrey W, Dalke A & Schulten K (1996) VMD: visual molecular dynamics. *Journal of molecular graphics* **14**: 33-38, 27-38.
- Iino T (1974) Assembly of *Salmonella* flagellin in vitro and in vivo. *Journal of supramolecular structure* **2**: 372-384.
- Ishino F, Mitsui K, Tamaki S & Matsushashi M (1980) Dual enzyme activities of cell wall peptidoglycan synthesis, peptidoglycan transglycosylase and penicillin-sensitive transpeptidase, in purified preparations of *Escherichia coli* penicillin-binding protein 1A. *Biochemical and biophysical research communications* **97**: 287-293.
- Izaki K, Matsushashi M & Strominger JL (1966) Glycopeptide transpeptidase and D-alanine carboxypeptidase: penicillin-sensitive enzymatic reactions. *Proceedings of the National Academy of Sciences of the United States of America* **55**: 656-663.
- J. F. Fisher SM (2015) Bacterial Cell Wall: Morphology and Biochemistry
Vol. 3rd edition ed. (eds.), p. pp. pp. 221. CRC Press, Boca Raton, FL.
- Jacobs C, Frere JM & Normark S (1997) Cytosolic intermediates for cell wall biosynthesis and degradation control inducible beta-lactam resistance in Gram-negative bacteria. *Cell* **88**: 823-832.
- Jacobs C, Huang LJ, Bartowsky E, Normark S & Park JT (1994) Bacterial cell wall recycling provides cytosolic muropeptides as effectors for beta-lactamase induction. *The EMBO journal* **13**: 4684-4694.
- Jacobs C, Joris B, Jamin M, *et al.* (1995) AmpD, essential for both beta-lactamase regulation and cell wall recycling, is a novel cytosolic N-acetylmuramyl-L-alanine amidase. *Molecular microbiology* **15**: 553-559.
- Jacoby GA (2009) AmpC beta-lactamases. *Clinical microbiology reviews* **22**: 161-182, Table of Contents.
- Jacoby GA, Blaser MJ, Santanam P, Hachler H, Kayser FH, Hare RS & Miller GH (1990) Appearance of amikacin and tobramycin resistance due to 4'-aminoglycoside nucleotidyltransferase [ANT(4')-II] in Gram-negative pathogens. *Antimicrobial agents and chemotherapy* **34**: 2381-2386.
- Janeway CA, Jr. (1989) Approaching the asymptote? Evolution and revolution in immunology. *Cold Spring Harbor symposia on quantitative biology* **54 Pt 1**: 1-13.

- Jansen G, Mahrt N, Tueffers L, *et al.* (2016) Association between clinical antibiotic resistance and susceptibility of *Pseudomonas* in the cystic fibrosis lung. *Evolution, medicine, and public health* **2016**: 182-194.
- Jennings LK, Storek KM, Ledvina HE, *et al.* (2015) Pel is a cationic exopolysaccharide that cross-links extracellular DNA in the *Pseudomonas aeruginosa* biofilm matrix. *Proceedings of the National Academy of Sciences of the United States of America* **112**: 11353-11358.
- Johnson JW, Fisher JF & Mobashery S (2013) Bacterial cell-wall recycling. *Annals of the New York Academy of Sciences* **1277**: 54-75.
- Jones CJ, Homma M & Macnab RM (1989) L-, P-, and M-ring proteins of the flagellar basal body of *Salmonella typhimurium*: gene sequences and deduced protein sequences. *Journal of bacteriology* **171**: 3890-3900.
- Jorgensen JH (1993) Antimicrobial susceptibility testing of bacteria that grow aerobically. *Infect Dis Clin North Am* **7**: 393-409.
- Jorgenson MA, Chen Y, Yahashiri A, Popham DL & Weiss DS (2014) The bacterial septal ring protein RlpA is a lytic transglycosylase that contributes to rod shape and daughter cell separation in *Pseudomonas aeruginosa*. *Molecular microbiology* **93**: 113-128.
- Juan C, Moya B, Perez JL & Oliver A (2006) Stepwise upregulation of the *Pseudomonas aeruginosa* chromosomal cephalosporinase conferring high-level beta-lactam resistance involves three AmpD homologues. *Antimicrobial agents and chemotherapy* **50**: 1780-1787.
- Juan C, Macia MD, Gutierrez O, Vidal C, Perez JL & Oliver A (2005) Molecular mechanisms of beta-lactam resistance mediated by AmpC hyperproduction in *Pseudomonas aeruginosa* clinical strains. *Antimicrobial agents and chemotherapy* **49**: 4733-4738.
- K. Yanagihara JK, S. Kohno (2001) Diffuse panbronchiolitis—pathophysiology and treatment mechanisms. *International Journal of Antimicrobial Agents* **18**: S83–S87.
- Kaczor AA, Polski A, Sobotka-Polska K, Pachuta-Stec A, Makarska-Bialokoz M & Pitucha M (2017) Novel antibacterial compounds and their drug targets - successes and challenges. *Current medicinal chemistry* **24**: 1948-1982.
- Kalva S, Boeke JD & Mita P (2018) Gibson Deletion: a novel application of isothermal in vitro recombination. *Biological procedures online* **20**: 2.
- Kamada Y, Nagaretani H, Tamura S, *et al.* (2001) Vascular endothelial dysfunction resulting from L-arginine deficiency in a patient with lysinuric protein intolerance. *The Journal of clinical investigation* **108**: 717-724.
- Kaneko K, Okamoto R, Nakano R, Kawakami S & Inoue M (2005) Gene mutations responsible for overexpression of AmpC beta-lactamase in some clinical isolates of *Enterobacter cloacae*. *Journal of clinical microbiology* **43**: 2955-2958.
- Kang CI, Kim SH, Kim HB, *et al.* (2003) *Pseudomonas aeruginosa* bacteremia: risk factors for mortality and influence of delayed receipt of effective antimicrobial therapy on clinical outcome. *Clinical infectious diseases : an official publication of the Infectious Diseases Society of America* **37**: 745-751.

- Kanj SS & Kanafani ZA (2011) Current concepts in antimicrobial therapy against resistant Gram-negative organisms: extended-spectrum beta-lactamase-producing Enterobacteriaceae, carbapenem-resistant Enterobacteriaceae, and multidrug-resistant *Pseudomonas aeruginosa*. *Mayo Clinic proceedings* **86**: 250-259.
- Kapatral V ZA, Kamath S, Chugani S (2000) *Pseudomonas*. . ed.^eds.), p.^pp. Academic Press, , New York, NY.
- Karim A, Poirel L, Nagarajan S & Nordmann P (2001) Plasmid-mediated extended-spectrum beta-lactamase (CTX-M-3 like) from India and gene association with insertion sequence ISEcp1. *FEMS microbiology letters* **201**: 237-241.
- Kaya S, Araki Y & Ito E (1989) The structure of the O-specific chain of lipopolysaccharide from *Pseudomonas aeruginosa* IID 1012 (ATCC 27588). *Journal of biochemistry* **105**: 29-34.
- Kearns DB (2010) A field guide to bacterial swarming motility. *Nature reviews. Microbiology* **8**: 634-644.
- Keep NH, Ward JM, Cohen-Gonsaud M & Henderson B (2006) Wake up! Peptidoglycan lysis and bacterial non-growth states. *Trends in microbiology* **14**: 271-276.
- Kerridge D, Horne RW & Glauert AM (1962) Structural components of flagella from *Salmonella typhimurium*. *Journal of molecular biology* **4**: 227-238.
- Keseler IM, Bonavides-Martinez C, Collado-Vides J, et al. (2009) EcoCyc: a comprehensive view of *Escherichia coli* biology. *Nucleic acids research* **37**: D464-470.
- Kessler E (1995) beta-lytic endopeptidases. *Methods in enzymology* **248**: 740-756.
- Kessler E, Safrin M, Olson JC & Ohman DE (1993) Secreted LasA of *Pseudomonas aeruginosa* is a staphylolytic protease. *The Journal of biological chemistry* **268**: 7503-7508.
- Kharazmi A (1989) Interactions of *Pseudomonas aeruginosa* proteases with the cells of the immune system. *Antibiotics and chemotherapy* **42**: 42-49.
- Kiehn TE (1989) Bacteremia and fungemia in the immunocompromised patient. *European journal of clinical microbiology & infectious diseases : official publication of the European Society of Clinical Microbiology* **8**: 832-837.
- Kielhofner M, Atmar RL, Hamill RJ & Musher DM (1992) Life-threatening *Pseudomonas aeruginosa* infections in patients with human immunodeficiency virus infection. *Clinical infectious diseases : an official publication of the Infectious Diseases Society of America* **14**: 403-411.
- King JD, Kocincova D, Westman EL & Lam JS (2009) Review: Lipopolysaccharide biosynthesis in *Pseudomonas aeruginosa*. *Innate immunity* **15**: 261-312.
- Kipnis E, Sawa T & Wiener-Kronish J (2006) Targeting mechanisms of *Pseudomonas aeruginosa* pathogenesis. *Medecine et maladies infectieuses* **36**: 78-91.
- Kitao T, Miyoshi-Akiyama T & Kirikae T (2009) AAC(6')-Iaf, a novel aminoglycoside 6'-N-acetyltransferase from multidrug-resistant *Pseudomonas aeruginosa* clinical isolates. *Antimicrobial agents and chemotherapy* **53**: 2327-2334.

- Klockgether J & Tummeler B (2017) Recent advances in understanding *Pseudomonas aeruginosa* as a pathogen. *F1000Research* **6**: 1261.
- Klockgether J, Cramer N, Wiehlmann L, Davenport CF & Tummeler B (2011) *Pseudomonas aeruginosa* genomic structure and diversity. *Frontiers in microbiology* **2**: 150.
- Koch AK, Kappeli O, Fiechter A & Reiser J (1991) Hydrocarbon assimilation and biosurfactant production in *Pseudomonas aeruginosa* mutants. *Journal of bacteriology* **173**: 4212-4219.
- Koch C & Hoiby N (1993) Pathogenesis of cystic fibrosis. *Lancet* **341**: 1065-1069.
- Koh AY, Priebe GP & Pier GB (2005) Virulence of *Pseudomonas aeruginosa* in a murine model of gastrointestinal colonization and dissemination in neutropenia. *Infection and immunity* **73**: 2262-2272.
- Kohanski MA, Dwyer DJ & Collins JJ (2010) How antibiotics kill bacteria: from targets to networks. *Nature reviews. Microbiology* **8**: 423-435.
- Kohler T, Epp SF, Curty LK & Pechere JC (1999) Characterization of MexT, the regulator of the MexE-MexF-OprN multidrug efflux system of *Pseudomonas aeruginosa*. *Journal of bacteriology* **181**: 6300-6305.
- Kohler T, Curty LK, Barja F, van Delden C & Pechere JC (2000) Swarming of *Pseudomonas aeruginosa* is dependent on cell-to-cell signaling and requires flagella and pili. *Journal of bacteriology* **182**: 5990-5996.
- Kohler T, Michea-Hamzehpour M, Henze U, Gotoh N, Curty LK & Pechere JC (1997) Characterization of MexE-MexF-OprN, a positively regulated multidrug efflux system of *Pseudomonas aeruginosa*. *Molecular microbiology* **23**: 345-354.
- Kohler T, Kok M, Michea-Hamzehpour M, *et al.* (1996) Multidrug efflux in intrinsic resistance to trimethoprim and sulfamethoxazole in *Pseudomonas aeruginosa*. *Antimicrobial agents and chemotherapy* **40**: 2288-2290.
- Kong F, Young L, Chen Y, *et al.* (2006) *Pseudomonas aeruginosa* pyocyanin inactivates lung epithelial vacuolar ATPase-dependent cystic fibrosis transmembrane conductance regulator expression and localization. *Cellular microbiology* **8**: 1121-1133.
- Kong KF, Schneper L & Mathee K (2010) Beta-lactam antibiotics: from antibiosis to resistance and bacteriology. *APMIS : acta pathologica, microbiologica, et immunologica Scandinavica* **118**: 1-36.
- Kong KF, Aguila A, Schneper L & Mathee K (2010) *Pseudomonas aeruginosa* beta-lactamase induction requires two permeases, AmpG and AmpP. *BMC microbiology* **10**: 328.
- Kong KF, Jayawardena SR, Del Puerto A, Wiehlmann L, Laabs U, Tummeler B & Mathee K (2005) Characterization of *poxB*, a chromosomal-encoded *Pseudomonas aeruginosa* oxacillinase. *Gene* **358**: 82-92.
- Kong KF, Jayawardena SR, Indulkar SD, Del Puerto A, Koh CL, Hoiby N & Mathee K (2005) *Pseudomonas aeruginosa* AmpR is a global transcriptional factor that regulates expression of AmpC and PoxB beta-lactamases, proteases, quorum sensing, and other virulence factors. *Antimicrobial agents and chemotherapy* **49**: 4567-4575.

- Koraimann G (2003) Lytic transglycosylases in macromolecular transport systems of Gram-negative bacteria. *Cellular and molecular life sciences : CMLS* **60**: 2371-2388.
- Korat B, Mottl H & Keck W (1991) Penicillin-binding protein 4 of *Escherichia coli*: molecular cloning of the *dacB* gene, controlled overexpression, and alterations in murein composition. *Molecular microbiology* **5**: 675-684.
- Korfmann G & Wiedemann B (1988) Genetic control of beta-lactamase production in *Enterobacter cloacae*. *Reviews of infectious diseases* **10**: 793-799.
- Korfmann G & Sanders CC (1989) *ampG* is essential for high-level expression of AmpC beta-lactamase in *Enterobacter cloacae*. *Antimicrobial agents and chemotherapy* **33**: 1946-1951.
- Korgaonkar AK & Whiteley M (2011) *Pseudomonas aeruginosa* enhances production of an antimicrobial in response to N-acetylglucosamine and peptidoglycan. *Journal of bacteriology* **193**: 909-917.
- Korza HJ & Bochtler M (2005) *Pseudomonas aeruginosa* LD-carboxypeptidase, a serine peptidase with a Ser-His-Glu triad and a nucleophilic elbow. *The Journal of biological chemistry* **280**: 40802-40812.
- Kotra LP, Haddad J & Mobashery S (2000) Aminoglycosides: perspectives on mechanisms of action and resistance and strategies to counter resistance. *Antimicrobial agents and chemotherapy* **44**: 3249-3256.
- Kraft AR, Templin MF & Holtje JV (1998) Membrane-bound lytic endotransglycosylase in *Escherichia coli*. *Journal of bacteriology* **180**: 3441-3447.
- Kraft AR, Prabhu J, Ursinus A & Holtje JV (1999) Interference with murein turnover has no effect on growth but reduces beta-lactamase induction in *Escherichia coli*. *Journal of bacteriology* **181**: 7192-7198.
- Kumari H, Balasubramanian D, Zincke D & Mathee K (2014) Role of *Pseudomonas aeruginosa* AmpR on beta-lactam and non-beta-lactam transient cross-resistance upon pre-exposure to subinhibitory concentrations of antibiotics. *Journal of medical microbiology* **63**: 544-555.
- Kumari H, Murugapiran SK, Balasubramanian D, *et al.* (2014) LTQ-XL mass spectrometry proteome analysis expands the *Pseudomonas aeruginosa* AmpR regulon to include cyclic di-GMP phosphodiesterases and phosphoproteins, and identifies novel open reading frames. *Journal of proteomics* **96**: 328-342.
- Kurachi M (1958) Studies on the Biosynthesis of Pyocyanine. (II) : Isolation and Determination of Pyocyanine. Vol. 36 ed.^eds.), p.^pp. 174-187. Bulletin of the Institute for Chemical Research, Kyoto.
- Kusar D, Srimpf K, Isakovic P, *et al.* (2016) Determination of N-acylhomoserine lactones of *Pseudomonas aeruginosa* in clinical samples from dogs with otitis externa. *BMC veterinary research* **12**: 233.
- Kwon JH, Belanger JM, Sigouin M, Lanthier J, Willemot C & Pare JJ (1990) Chemical constituents of Panax ginseng exposed to gamma. irradiation. *Journal of Agricultural and Food Chemistry* **38**: 830-834.

- Lamas Ferreiro JL, Alvarez Otero J, Gonzalez Gonzalez L, *et al.* (2017) *Pseudomonas aeruginosa* urinary tract infections in hospitalized patients: Mortality and prognostic factors. *PLoS one* **12**: e0178178.
- Lambert PA (2002) Mechanisms of antibiotic resistance in *Pseudomonas aeruginosa*. *Journal of the Royal Society of Medicine* **95 Suppl 41**: 22-26.
- Lamers RP, Nguyen UT, Nguyen Y, Buensuceso RN & Burrows LL (2015) Loss of membrane-bound lytic transglycosylases increases outer membrane permeability and beta-lactam sensitivity in *Pseudomonas aeruginosa*. *MicrobiologyOpen* **4**: 879-895.
- Lang AB, Horn MP, Imboden MA & Zuercher AW (2004) Prophylaxis and therapy of *Pseudomonas aeruginosa* infection in cystic fibrosis and immunocompromised patients. *Vaccine* **22 Suppl 1**: S44-48.
- Langaee TY, Gagnon L & Huletsky A (2000) Inactivation of the *ampD* gene in *Pseudomonas aeruginosa* leads to moderate-basal-level and hyperinducible AmpC beta-lactamase expression. *Antimicrobial agents and chemotherapy* **44**: 583-589.
- Langan KM, Kotsimbos T & Peleg AY (2015) Managing *Pseudomonas aeruginosa* respiratory infections in cystic fibrosis. *Current opinion in infectious diseases* **28**: 547-556.
- Larsen MW, Moser C, Hoiby N, Song Z & Kharazmi A (2004) Ginseng modulates the immune response by induction of interleukin-12 production. *APMIS : acta pathologica, microbiologica, et immunologica Scandinavica* **112**: 369-373.
- Latifi A, Winson MK, Foglino M, Bycroft BW, Stewart GS, Lazdunski A & Williams P (1995) Multiple homologues of LuxR and LuxI control expression of virulence determinants and secondary metabolites through quorum sensing in *Pseudomonas aeruginosa* PAO1. *Molecular microbiology* **17**: 333-343.
- Lauretti L, Riccio ML, Mazzariol A, Cornaglia G, Amicosante G, Fontana R & Rossolini GM (1999) Cloning and characterization of *bla_{VIM}*, a new integron-borne metallo-beta-lactamase gene from a *Pseudomonas aeruginosa* clinical isolate. *Antimicrobial agents and chemotherapy* **43**: 1584-1590.
- Leclercq S, Derouaux A, Olatunji S, *et al.* (2017) Interplay between penicillin-binding proteins and SEDS proteins promotes bacterial cell wall synthesis. *Scientific reports* **7**: 43306.
- Lee DG, Urbach JM, Wu G, *et al.* (2006) Genomic analysis reveals that *Pseudomonas aeruginosa* virulence is combinatorial. *Genome biology* **7**: R90.
- Lee EJ, Evans DJ & Fleiszig SM (2003) Role of *Pseudomonas aeruginosa* ExsA in penetration through corneal epithelium in a novel in vivo model. *Investigative ophthalmology & visual science* **44**: 5220-5227.
- Lee J, Wu J, Deng Y, *et al.* (2013) A cell-cell communication signal integrates quorum sensing and stress response. *Nature chemical biology* **9**: 339-343.
- Lee M, Zhang W, Heseck D, Noll BC, Boggess B & Mobashery S (2009) Bacterial AmpD at the crossroads of peptidoglycan recycling and manifestation of antibiotic resistance. *Journal of the American Chemical Society* **131**: 8742-8743.

- Lee M, Heseck D, Shah IM, Oliver AG, Dworkin J & Mobashery S (2010) Synthetic peptidoglycan motifs for germination of bacterial spores. *Chembiochem : a European journal of chemical biology* **11**: 2525-2529.
- Lee M, Heseck D, Llarrull LI, Lastochkin E, Pi H, Boggess B & Mobashery S (2013) Reactions of all *Escherichia coli* lytic transglycosylases with bacterial cell wall. *Journal of the American Chemical Society* **135**: 3311-3314.
- Lee M, Heseck D, Blazquez B, Lastochkin E, Boggess B, Fisher JF & Mobashery S (2015) Catalytic spectrum of the penicillin-binding protein 4 of *Pseudomonas aeruginosa*, a nexus for the induction of beta-lactam antibiotic resistance. *Journal of the American Chemical Society* **137**: 190-200.
- Lee M, Dominguez-Gil T, Heseck D, Mahasenan KV, Lastochkin E, Hermoso JA & Mobashery S (2016) Turnover of bacterial cell wall by SltB3, a multidomain lytic transglycosylase of *Pseudomonas aeruginosa*. *ACS chemical biology*.
- Lee M, Dhar S, De Benedetti S, *et al.* (2016) Muropeptides in *Pseudomonas aeruginosa* and their role as elicitors of beta-lactam-antibiotic resistance. *Angewandte Chemie*.
- Lee M, Dhar S, De Benedetti S, *et al.* (2016) Corrigendum: Muropeptides in *Pseudomonas aeruginosa* and their role as elicitors of beta-lactam-antibiotic resistance. *Angewandte Chemie* **55**: 12568.
- Lee M, Heseck D, Dik DA, *et al.* (2017) From genome to proteome to elucidation of reactions for all eleven known lytic transglycosylases from *Pseudomonas aeruginosa*. *Angewandte Chemie* **56**: 2735-2739.
- Lee M, Artola-Recolons C, Carrasco-Lopez C, *et al.* (2013) Cell-wall remodeling by the zinc-protease AmpDh3 from *Pseudomonas aeruginosa*. *Journal of the American Chemical Society* **135**: 12604-12607.
- Legaree BA, Daniels K, Weadge JT, Cockburn D & Clarke AJ (2007) Function of penicillin-binding protein 2 in viability and morphology of *Pseudomonas aeruginosa*. *The Journal of antimicrobial chemotherapy* **59**: 411-424.
- Legnani P, Leoni E, Rapuano S, Turin D & Valenti C (1999) Survival and growth of *Pseudomonas aeruginosa* in natural mineral water: a 5-year study. *International journal of food microbiology* **53**: 153-158.
- Leung KW & Wong AS (2010) Pharmacology of ginsenosides: a literature review. *Chinese medicine* **5**: 20.
- Li H, Luo YF, Williams BJ, Blackwell TS & Xie CM (2012) Structure and function of OprD protein in *Pseudomonas aeruginosa*: from antibiotic resistance to novel therapies. *International journal of medical microbiology : IJMM* **302**: 63-68.
- Li P, Ying J, Yang G, *et al.* (2016) Structure-function analysis of the transmembrane protein AmpG from *Pseudomonas aeruginosa*. *PloS one* **11**: e0168060.
- Li XZ, Nikaido H & Poole K (1995) Role of *mexA-mexB-oprM* in antibiotic efflux in *Pseudomonas aeruginosa*. *Antimicrobial agents and chemotherapy* **39**: 1948-1953.
- Li Y, Mima T, Komori Y, Morita Y, Kuroda T, Mizushima T & Tsuchiya T (2003) A new member of the tripartite multidrug efflux pumps, MexVW-OprM, in *Pseudomonas aeruginosa*. *The Journal of antimicrobial chemotherapy* **52**: 572-575.

- Li Z, Clarke AJ & Beveridge TJ (1996) A major autolysin of *Pseudomonas aeruginosa*: subcellular distribution, potential role in cell growth and division and secretion in surface membrane vesicles. *Journal of bacteriology* **178**: 2479-2488.
- Liao X & Hancock RE (1997) Identification of a penicillin-binding protein 3 homolog, PBP3x, in *Pseudomonas aeruginosa*: gene cloning and growth phase-dependent expression. *Journal of bacteriology* **179**: 1490-1496.
- Lindberg F & Normark S (1987) Common mechanism of *ampC* beta-lactamase induction in enterobacteria: regulation of the cloned *Enterobacter cloacae* P99 beta-lactamase gene. *Journal of bacteriology* **169**: 758-763.
- Lindquist S, Galleni M, Lindberg F & Normark S (1989) Signalling proteins in enterobacterial AmpC beta-lactamase regulation. *Molecular microbiology* **3**: 1091-1102.
- Lindquist S, Weston-Hafer K, Schmidt H, *et al.* (1993) AmpG, a signal transducer in chromosomal beta-lactamase induction. *Molecular microbiology* **9**: 703-715.
- Lister PD, Wolter DJ & Hanson ND (2009) Antibacterial-resistant *Pseudomonas aeruginosa*: clinical impact and complex regulation of chromosomally encoded resistance mechanisms. *Clinical microbiology reviews* **22**: 582-610.
- Livermore DM (1995) beta-Lactamases in laboratory and clinical resistance. *Clinical microbiology reviews* **8**: 557-584.
- Livermore DM (2002) Multiple mechanisms of antimicrobial resistance in *Pseudomonas aeruginosa*: our worst nightmare? *Clinical infectious diseases : an official publication of the Infectious Diseases Society of America* **34**: 634-640.
- Lodge J, Busby S & Piddock L (1993) Investigation of the *Pseudomonas aeruginosa ampR* gene and its role at the chromosomal *ampC* beta-lactamase promoter. *FEMS microbiology letters* **111**: 315-320.
- Lodge JM, Minchin SD, Piddock LJ & Busby SJ (1990) Cloning, sequencing and analysis of the structural gene and regulatory region of the *Pseudomonas aeruginosa* chromosomal *ampC* beta-lactamase. *The Biochemical journal* **272**: 627-631.
- Lommatzsch J, Templin MF, Kraft AR, Vollmer W & Holtje JV (1997) Outer membrane localization of murein hydrolases: MltA, a third lipoprotein lytic transglycosylase in *Escherichia coli*. *Journal of bacteriology* **179**: 5465-5470.
- Lopez-Vallejo F, Giulianotti MA, Houghten RA & Medina-Franco JL (2012) Expanding the medicinally relevant chemical space with compound libraries. *Drug discovery today* **17**: 718-726.
- Lovering AM, White LO & Reeves DS (1987) AAC(1): a new aminoglycoside-acetylating enzyme modifying the C1 aminogroup of apramycin. *The Journal of antimicrobial chemotherapy* **20**: 803-813.
- Luker KE, Collier JL, Kolodziej EW, Marshall GR & Goldman WE (1993) *Bordetella pertussis* tracheal cytotoxin and other muramyl peptides: distinct structure-activity relationships for respiratory epithelial cytopathology. *Proceedings of the National Academy of Sciences of the United States of America* **90**: 2365-2369.
- Lyczak JB, Cannon CL & Pier GB (2000) Establishment of *Pseudomonas aeruginosa* infection: lessons from a versatile opportunist. *Microbes and infection / Institut Pasteur* **2**: 1051-1060.

- Lyczak JB, Cannon CL & Pier GB (2000) Establishment of *Pseudomonas aeruginosa* infection: lessons from a versatile opportunist. *Microbes and infection* **2**: 1051-1060.
- Lyczak JB, Cannon CL & Pier GB (2002) Lung infections associated with cystic fibrosis. *Clinical microbiology reviews* **15**: 194-222.
- Lynch SV & Wiener-Kronish JP (2008) Novel strategies to combat bacterial virulence. *Current opinion in critical care* **14**: 593-599.
- Lysenko O (1961) *Pseudomonas*--an attempt at a general classification. *Journal of general microbiology* **25**: 379-408.
- Ma L, Wang S, Wang D, Parsek MR & Wozniak DJ (2012) The roles of biofilm matrix polysaccharide Psl in mucoid *Pseudomonas aeruginosa* biofilms. *FEMS immunology and medical microbiology* **65**: 377-380.
- Makemson J, Eberhard A & Mathee K (2006) Simple electrospray mass spectrometry detection of acylhomoserine lactones. *Luminescence : the journal of biological and chemical luminescence* **21**: 1-6.
- Marchler-Bauer A, Bo Y, Han L, *et al.* (2017) CDD/SPARCLE: functional classification of proteins via subfamily domain architectures. *Nucleic acids research* **45**: D200-D203.
- Marks MI (1981) The pathogenesis and treatment of pulmonary infections in patients with cystic fibrosis. *The Journal of pediatrics* **98**: 173-179.
- Marks MI (1990) Clinical significance of *Staphylococcus aureus* in cystic fibrosis. *Infection* **18**: 53-56.
- Marshall B, Faro A, Elbert A, *et al.* (2016) Cystic Fibrosis Foundation Patient Registry. ed.^{eds.}), p.^{pp.}
- Martinez-Caballero S, Lee M, Artola-Recolons C, *et al.* (2013) Reaction products and the X-ray structure of AmpDh2, a virulence determinant of *Pseudomonas aeruginosa*. *Journal of the American Chemical Society* **135**: 10318-10321.
- Martinez-Solano L, Macia MD, Fajardo A, Oliver A & Martinez JL (2008) Chronic *Pseudomonas aeruginosa* infection in chronic obstructive pulmonary disease. *Clinical infectious diseases : an official publication of the Infectious Diseases Society of America* **47**: 1526-1533.
- Marvig RL, Sommer LM, Molin S & Johansen HK (2015) Convergent evolution and adaptation of *Pseudomonas aeruginosa* within patients with cystic fibrosis. *Nature genetics* **47**: 57-64.
- Mathee K, Ciofu O, Sternberg C, *et al.* (1999) Mucoid conversion of *Pseudomonas aeruginosa* by hydrogen peroxide: a mechanism for virulence activation in the cystic fibrosis lung. *Microbiology* **145 (Pt 6)**: 1349-1357.
- Mathee K, Narasimhan G, Valdes C, *et al.* (2008) Dynamics of *Pseudomonas aeruginosa* genome evolution. *Proceedings of the National Academy of Sciences of the United States of America* **105**: 3100-3105.
- Matias VR & Beveridge TJ (2007) Cryo-electron microscopy of cell division in *Staphylococcus aureus* reveals a mid-zone between nascent cross walls. *Molecular microbiology* **64**: 195-206.

- Matias VR, Al-Amoudi A, Dubochet J & Beveridge TJ (2003) Cryo-transmission electron microscopy of frozen-hydrated sections of *Escherichia coli* and *Pseudomonas aeruginosa*. *Journal of bacteriology* **185**: 6112-6118.
- Matsushashi M, Tamaki S, Curtis SJ & Strominger JL (1979) Mutational evidence for identity of penicillin-binding protein 5 in *Escherichia coli* with the major D-alanine carboxypeptidase IA activity. *Journal of bacteriology* **137**: 644-647.
- Matthew M (1979) Plasmid-mediated beta-lactamases of Gram-negative bacteria: properties and distribution. *The Journal of antimicrobial chemotherapy* **5**: 349-358.
- Matthew M, Hedges RW & Smith JT (1979) Types of beta-lactamase determined by plasmids in Gram-negative bacteria. *Journal of bacteriology* **138**: 657-662.
- Mauck J, Chan L & Glaser L (1971) Turnover of the cell wall of Gram-positive bacteria. *The Journal of biological chemistry* **246**: 1820-1827.
- Mavrodi DV, Bonsall RF, Delaney SM, Soule MJ, Phillips G & Thomashow LS (2001) Functional analysis of genes for biosynthesis of pyocyanin and phenazine-1-carboxamide from *Pseudomonas aeruginosa* PAO1. *Journal of bacteriology* **183**: 6454-6465.
- McDonald C, Inohara N & Nunez G (2005) Peptidoglycan signaling in innate immunity and inflammatory disease. *The Journal of biological chemistry* **280**: 20177-20180.
- McManus AT, Mason AD, Jr., McManus WF & Pruitt BA, Jr. (1985) Twenty-five year review of *Pseudomonas aeruginosa* bacteremia in a burn center. *European journal of clinical microbiology* **4**: 219-223.
- McMorran B, Town L, Costelloe E, Palmer J, Engel J, Hume D & Wainwright B (2003) Effector ExoU from the type III secretion system is an important modulator of gene expression in lung epithelial cells in response to *Pseudomonas aeruginosa* infection. *Infection and immunity* **71**: 6035-6044.
- Meberg BM, Paulson AL, Priyadarshini R & Young KD (2004) Endopeptidase penicillin-binding proteins 4 and 7 play auxiliary roles in determining uniform morphology of *Escherichia coli*. *Journal of bacteriology* **186**: 8326-8336.
- Medeiros AA (1997) Evolution and dissemination of beta-lactamases accelerated by generations of beta-lactam antibiotics. *Clinical infectious diseases : an official publication of the Infectious Diseases Society of America* **24 Suppl 1**: S19-45.
- Meeske AJ, Sham LT, Kimsey H, Koo BM, Gross CA, Bernhardt TG & Rudner DZ (2015) MurJ and a novel lipid II flippase are required for cell wall biogenesis in *Bacillus subtilis*. *Proceedings of the National Academy of Sciences of the United States of America* **112**: 6437-6442.
- Melvin P. Weinstein M (2018) Performance standards for antimicrobial susceptibility testing. ed.^eds.), p.^pp. 296.
- Mena KD & Gerba CP (2009) Risk assessment of *Pseudomonas aeruginosa* in water. *Reviews of environmental contamination and toxicology* **201**: 71-115.
- Mengin-Lecreulx D & van Heijenoort J (1994) Copurification of glucosamine-1-phosphate acetyltransferase and N-acetylglucosamine-1-phosphate uridylyltransferase activities of *Escherichia coli*: characterization of the *glmU* gene product as a bifunctional

enzyme catalyzing two subsequent steps in the pathway for UDP-N-acetylglucosamine synthesis. *Journal of bacteriology* **176**: 5788-5795.

Mengin-Lecreulx D & van Heijenoort J (1996) Characterization of the essential gene *glmM* encoding phosphoglucosamine mutase in *Escherichia coli*. *The Journal of biological chemistry* **271**: 32-39.

Mengin-Lecreulx D, van Heijenoort J & Park JT (1996) Identification of the *mpl* gene encoding UDP-N-acetylmuramate: L-alanyl-gamma-D-glutamyl-meso-diaminopimelate ligase in *Escherichia coli* and its role in recycling of cell wall peptidoglycan. *Journal of bacteriology* **178**: 5347-5352.

Mengin-Lecreulx D, Texier L, Rousseau M & van Heijenoort J (1991) The *murG* gene of *Escherichia coli* codes for the UDP-N-acetylglucosamine: N-acetylmuramyl-(pentapeptide) pyrophosphoryl-undecaprenol N-acetylglucosamine transferase involved in the membrane steps of peptidoglycan synthesis. *Journal of bacteriology* **173**: 4625-4636.

Mercier F, Zervosen A, Teller N, *et al.* (2010) 1,6-AnhMurNAc derivatives for assay development of amidase AmiD. *Bioorganic & medicinal chemistry* **18**: 7422-7431.

Miall LS, McGinley NT, Brownlee KG & Conway SP (2001) Methicillin resistant *Staphylococcus aureus* (MRSA) infection in cystic fibrosis. *Archives of disease in childhood* **84**: 160-162.

Michel L, Bachelard A & Reimann C (2007) Ferripyochelin uptake genes are involved in pyochelin-mediated signalling in *Pseudomonas aeruginosa*. *Microbiology* **153**: 1508-1518.

Mielcarek N, Debie AS, Raze D, *et al.* (2006) Live attenuated *B. pertussis* as a single-dose nasal vaccine against whooping cough. *PLoS pathogens* **2**: e65.

Miyayama Y, Yanagihara K, Kaku N, *et al.* (2016) *Pseudomonas aeruginosa* bacteremia among immunocompetent and immunocompromised patients: relation to initial antibiotic therapy and survival. *Japanese journal of infectious diseases* **69**: 91-96.

Miller MB & Bassler BL (2001) Quorum sensing in bacteria. *Annual Reviews in Microbiology* **55**: 165-199.

Mima T, Joshi S, Gomez-Escalada M & Schweizer HP (2007) Identification and characterization of TriABC-OpmH, a triclosan efflux pump of *Pseudomonas aeruginosa* requiring two membrane fusion proteins. *Journal of bacteriology* **189**: 7600-7609.

Mima T, Sekiya H, Mizushima T, Kuroda T & Tsuchiya T (2005) Gene cloning and properties of the RND-type multidrug efflux pumps MexPQ-OpmE and MexMN-OprM from *Pseudomonas aeruginosa*. *Microbiology and immunology* **49**: 999-1002.

Mima T, Kohira N, Li Y, Sekiya H, Ogawa W, Kuroda T & Tsuchiya T (2009) Gene cloning and characteristics of the RND-type multidrug efflux pump MuxABC-OpmB possessing two RND components in *Pseudomonas aeruginosa*. *Microbiology* **155**: 3509-3517.

Mine T, Morita Y, Kataoka A, Mizushima T & Tsuchiya T (1999) Expression in *Escherichia coli* of a new multidrug efflux pump, MexXY, from *Pseudomonas aeruginosa*. *Antimicrobial agents and chemotherapy* **43**: 415-417.

- Mitsuhashi S IM (1981) Mechanisms of resistance to beta-Lactam antibiotics. In S. Mitsuhashi (ed.), *Beta-lactam antibiotics* p. 41–56.
- Mohammadi T, van Dam V, Sijbrandi R, et al. (2011) Identification of FtsW as a transporter of lipid-linked cell wall precursors across the membrane. *The EMBO journal* **30**: 1425-1432.
- Mondon M, Hur S, Vadlamani G, et al. (2013) Selective trihydroxyazepane NagZ inhibitors increase sensitivity of *Pseudomonas aeruginosa* to beta-lactams. *Chemical communications* **49**: 10983-10985.
- Moore RA, DeShazer D, Reckseidler S, Weissman A & Woods DE (1999) Efflux-mediated aminoglycoside and macrolide resistance in *Burkholderia pseudomallei*. *Antimicrobial agents and chemotherapy* **43**: 465-470.
- Morita Y, Tomida J & Kawamura Y (2012) MexXY multidrug efflux system of *Pseudomonas aeruginosa*. *Frontiers in microbiology* **3**: 408.
- Moya B, Juan C, Alberti S, Perez JL & Oliver A (2008) Benefit of having multiple *ampD* genes for acquiring beta-lactam resistance without losing fitness and virulence in *Pseudomonas aeruginosa*. *Antimicrobial agents and chemotherapy* **52**: 3694-3700.
- Moya B, Dotsch A, Juan C, Blazquez J, Zamorano L, Haussler S & Oliver A (2009) Beta-lactam resistance response triggered by inactivation of a nonessential penicillin-binding protein. *PLoS pathogens* **5**: e1000353.
- Moya B, Beceiro A, Cabot G, Juan C, Zamorano L, Alberti S & Oliver A (2012) Pan-beta-lactam resistance development in *Pseudomonas aeruginosa* clinical strains: molecular mechanisms, penicillin-binding protein profiles, and binding affinities. *Antimicrobial agents and chemotherapy* **56**: 4771-4778.
- Mugnier P, Casin I, Bouthors AT & Collatz E (1998) Novel OXA-10-derived extended-spectrum beta-lactamases selected in vivo or in vitro. *Antimicrobial agents and chemotherapy* **42**: 3113-3116.
- Mukamolova GV, Murzin AG, Salina EG, Demina GR, Kell DB, Kaprelyants AS & Young M (2006) Muralytic activity of *Micrococcus luteus* Rpf and its relationship to physiological activity in promoting bacterial growth and resuscitation. *Molecular microbiology* **59**: 84-98.
- Muramatsu H, Horii T, Morita M, Hashimoto H, Kanno T & Maekawa M (2003) Effect of basic amino acids on susceptibility to carbapenems in clinical *Pseudomonas aeruginosa* isolates. *International journal of medical microbiology : IJMM* **293**: 191-197.
- Nakagawa J, Tamaki S, Tomioka S & Matsushashi M (1984) Functional biosynthesis of cell wall peptidoglycan by polymorphic bifunctional polypeptides. Penicillin-binding protein 1Bs of *Escherichia coli* with activities of transglycosylase and transpeptidase. *The Journal of biological chemistry* **259**: 13937-13946.
- Nakamura M, Maruyama IN, Soma M, Kato J, Suzuki H & Horota Y (1983) On the process of cellular division in *Escherichia coli*: nucleotide sequence of the gene for penicillin-binding protein 3. *Molecular & general genetics : MGG* **191**: 1-9.
- Nakamura S, Nakamura M, Kojima T & Yoshida H (1989) *gyrA* and *gyrB* mutations in quinolone-resistant strains of *Escherichia coli*. *Antimicrobial agents and chemotherapy* **33**: 254-255.

- Nambu T, Minamino T, Macnab RM & Kutsukake K (1999) Peptidoglycan-hydrolyzing activity of the FlgJ protein, essential for flagellar rod formation in *Salmonella typhimurium*. *J Bacteriol* **181**: 1555-1561.
- Nealson KH & Hastings JW (1979) Bacterial bioluminescence: its control and ecological significance. *Microbiological reviews* **43**: 496-518.
- Nefzi A, Ostresh JM, Yu Y & Houghten RA (2004) Combinatorial chemistry: libraries from libraries, the art of the diversity-oriented transformation of resin-bound peptides and chiral polyamides to low molecular weight acyclic and heterocyclic compounds. *The Journal of organic chemistry* **69**: 3603-3609.
- Nelson DE & Young KD (2000) Penicillin binding protein 5 affects cell diameter, contour, and morphology of *Escherichia coli*. *Journal of bacteriology* **182**: 1714-1721.
- Nelson DE & Young KD (2001) Contributions of PBP 5 and DD-carboxypeptidase penicillin binding proteins to maintenance of cell shape in *Escherichia coli*. *Journal of bacteriology* **183**: 3055-3064.
- Nguyen-Disteche M, Fraipont C, Buddelmeijer N & Nanninga N (1998) The structure and function of *Escherichia coli* penicillin-binding protein 3. *Cellular and molecular life sciences : CMLS* **54**: 309-316.
- Nicas TI & Hancock RE (1983) *Pseudomonas aeruginosa* outer membrane permeability: isolation of a porin protein F-deficient mutant. *Journal of bacteriology* **153**: 281-285.
- Nikaido H, Nikaido K & Harayama S (1991) Identification and characterization of porins in *Pseudomonas aeruginosa*. *The Journal of biological chemistry* **266**: 770-779.
- Nishino N & Powers JC (1980) *Pseudomonas aeruginosa* elastase. Development of a new substrate, inhibitors, and an affinity ligand. *The Journal of biological chemistry* **255**: 3482-3486.
- Noguchi H, Matsuhashi M & Mitsuhashi S (1979) Comparative studies of penicillin-binding proteins in *Pseudomonas aeruginosa* and *Escherichia coli*. *European journal of biochemistry / FEBS* **100**: 41-49.
- Noguchi H, Fukasawa M, Komatsu T, Mitsuhashi S & Matsuhashi M (1985) Mutation in *Pseudomonas aeruginosa* causing simultaneous defects in penicillin-binding protein 5 and in enzyme activities of penicillin release and D-alanine carboxypeptidase. *Journal of bacteriology* **162**: 849-851.
- Nordmann P, Ronco E, Naas T, Duport C, Michel-Briand Y & Labia R (1993) Characterization of a novel extended-spectrum beta-lactamase from *Pseudomonas aeruginosa*. *Antimicrobial agents and chemotherapy* **37**: 962-969.
- Normark S (1995) beta-Lactamase induction in Gram-negative bacteria is intimately linked to peptidoglycan recycling. *Microbial drug resistance* **1**: 111-114.
- Normark S & Lindberg F (1985) Evolution of resistance to penicillin and cephalosporin antibiotics. *BioEssays : news and reviews in molecular, cellular and developmental biology* **3**: 22-26.
- Nossal NG & Heppel LA (1966) The release of enzymes by osmotic shock from *Escherichia coli* in exponential phase. *The Journal of biological chemistry* **241**: 3055-3062.

- O'Callaghan CH, Morris A, Kirby SM & Shingler AH (1972) Novel method for detection of beta-lactamases by using a chromogenic cephalosporin substrate. *Antimicrobial agents and chemotherapy* **1**: 283-288.
- O'Loughlin CT, Miller LC, Siryaporn A, Drescher K, Semmelhack MF & Bassler BL (2013) A quorum-sensing inhibitor blocks *Pseudomonas aeruginosa* virulence and biofilm formation. *Proceedings of the National Academy of Sciences of the United States of America* **110**: 17981-17986.
- O'Toole GA (2011) Microtiter dish biofilm formation assay. *Journal of visualized experiments : JoVE*.
- O'Toole GA & Kolter R (1998) Flagellar and twitching motility are necessary for *Pseudomonas aeruginosa* biofilm development. *Molecular microbiology* **30**: 295-304.
- Ochs MM, Lu CD, Hancock RE & Abdelal AT (1999) Amino acid-mediated induction of the basic amino acid-specific outer membrane porin OprD from *Pseudomonas aeruginosa*. *Journal of bacteriology* **181**: 5426-5432.
- Ochsner UA, Fiechter A & Reiser J (1994) Isolation, characterization, and expression in *Escherichia coli* of the *Pseudomonas aeruginosa* *rhlAB* genes encoding a rhamnosyltransferase involved in rhamnolipid biosurfactant synthesis. *The Journal of biological chemistry* **269**: 19787-19795.
- Ochsner UA, Wilderman PJ, Vasil AI & Vasil ML (2002) GeneChip expression analysis of the iron starvation response in *Pseudomonas aeruginosa*: identification of novel pyoverdine biosynthesis genes. *Molecular microbiology* **45**: 1277-1287.
- Oh H, Stenhoff J, Jalal S & Wretling B (2003) Role of efflux pumps and mutations in genes for topoisomerases II and IV in fluoroquinolone-resistant *Pseudomonas aeruginosa* strains. *Microbial drug resistance* **9**: 323-328.
- Ohman DE, Cryz SJ & Iglewski BH (1980) Isolation and characterization of *Pseudomonas aeruginosa* PAO mutant that produces altered elastase. *Journal of bacteriology* **142**: 836-842.
- Okazaki A & Avison MB (2008) Induction of L1 and L2 beta-lactamase production in *Stenotrophomonas maltophilia* is dependent on an AmpR-type regulator. *Antimicrobial agents and chemotherapy* **52**: 1525-1528.
- Oldenburg KR, Vo KT, Michaelis S & Paddon C (1997) Recombination-mediated PCR-directed plasmid construction in vivo in yeast. *Nucleic Acids Res* **25**: 451-452.
- Olsen RH, DeBusscher G & McCombie WR (1982) Development of broad-host-range vectors and gene banks: self-cloning of the *Pseudomonas aeruginosa* PAO chromosome. *Journal of bacteriology* **150**: 60-69.
- Osmon S, Ward S, Fraser VJ & Kollef MH (2004) Hospital mortality for patients with bacteremia due to *Staphylococcus aureus* or *Pseudomonas aeruginosa*. *Chest* **125**: 607-616.
- Page B, Page M & Noel C (1993) A new fluorometric assay for cytotoxicity measurements in-vitro. *International journal of oncology* **3**: 473-476.
- Palleroni N (2001) *Pseudomonadaceae*. ed. ^eds.), p. ^pp. Baltimore, MD.

- Palleroni NJ (2010) The *Pseudomonas* story. *Environmental microbiology* **12**: 1377-1383.
- Palleroni NJaM, R.B.E. (2004) *Pseudomonas*: Genomics, lifestyle and molecular architecture. (Ramos J-L, ed.^eds.), p.^pp. Springer US.
- Palzkill T (2013) Metallo-beta-lactamase structure and function. *Annals of the New York Academy of Sciences* **1277**: 91-104.
- Panda SK, Mohanta YK, Padhi L, Park YH, Mohanta TK & Bae H (2016) Large scale screening of ethnomedicinal plants for identification of potential antibacterial compounds. *Molecules* **21**: 293.
- Papanicolaou GA, Medeiros AA & Jacoby GA (1990) Novel plasmid-mediated beta-lactamase (MIR-1) conferring resistance to oxyimino- and alpha-methoxy beta-lactams in clinical isolates of *Klebsiella pneumoniae*. *Antimicrobial agents and chemotherapy* **34**: 2200-2209.
- Papenfort K & Bassler BL (2016) Quorum sensing signal-response systems in Gram-negative bacteria. *Nature reviews. Microbiology* **14**: 576-588.
- Park H, Cho B-G & Lee M-K (1990) Nitrogen compounds of Korea ginseng and their physiological significance. *Journal of Ginseng Research* **14**: 317-331.
- Park JT (1993) Turnover and recycling of the murein sacculus in oligopeptide permease-negative strains of *Escherichia coli*: indirect evidence for an alternative permease system and for a monolayered sacculus. *Journal of bacteriology* **175**: 7-11.
- Park JT (2001) Identification of a dedicated recycling pathway for anhydro-N-acetylmuramic acid and N-acetylglucosamine derived from *Escherichia coli* cell wall murein. *Journal of bacteriology* **183**: 3842-3847.
- Park JT & Burman LG (1985) Elongation of the murein sacculus of *Escherichia coli*. *Annales de l'Institut Pasteur. Microbiologie* **136A**: 51-58.
- Park JT & Uehara T (2008) How bacteria consume their own exoskeletons (turnover and recycling of cell wall peptidoglycan). *Microbiology and molecular biology reviews* : *MMBR* **72**: 211-227, table of contents.
- Parsek MR, Val DL, Hanzelka BL, Cronan JE, Jr. & Greenberg EP (1999) Acyl homoserine-lactone quorum-sensing signal generation. *Proceedings of the National Academy of Sciences of the United States of America* **96**: 4360-4365.
- Paterson DL & Bonomo RA (2005) Extended-spectrum beta-lactamases: a clinical update. *Clinical microbiology reviews* **18**: 657-686.
- Patriquin GM, Banin E, Gilmour C, Tuchman R, Greenberg EP & Poole K (2008) Influence of quorum sensing and iron on twitching motility and biofilm formation in *Pseudomonas aeruginosa*. *Journal of bacteriology* **190**: 662-671.
- Payne DJ, Cramp R, Winstanley DJ & Knowles DJ (1994) Comparative activities of clavulanic acid, sulbactam, and tazobactam against clinically important beta-lactamases. *Antimicrobial agents and chemotherapy* **38**: 767-772.
- Pearson JP, Pesci EC & Iglewski BH (1997) Roles of *Pseudomonas aeruginosa las* and *rhl* quorum-sensing systems in control of elastase and rhamnolipid biosynthesis genes. *Journal of bacteriology* **179**: 5756-5767.

- Pearson JP, Passador L, Iglewski BH & Greenberg EP (1995) A second N-acylhomoserine lactone signal produced by *Pseudomonas aeruginosa*. *Proceedings of the National Academy of Sciences of the United States of America* **92**: 1490-1494.
- Pedersen SS (1992) Lung infection with alginate-producing, mucoid *Pseudomonas aeruginosa* in cystic fibrosis. *APMIS. Supplementum* **28**: 1-79.
- Pedersen SS, Kharazmi A, Espersen F & Hoiby N (1990) *Pseudomonas aeruginosa* alginate in cystic fibrosis sputum and the inflammatory response. *Infection and immunity* **58**: 3363-3368.
- Pepper JW (2008) Defeating pathogen drug resistance: guidance from evolutionary theory. *Evolution; international journal of organic evolution* **62**: 3185-3191.
- Pereira SG, Rosa AC, Ferreira AS, Moreira LM, Proenca DN, Morais PV & Cardoso O (2014) Virulence factors and infection ability of *Pseudomonas aeruginosa* isolates from a hydropathic facility and respiratory infections. *Journal of applied microbiology* **116**: 1359-1368.
- Perkins HR (1963) Chemical structure and biosynthesis of bacterial cell walls. *Bacteriological reviews* **27**: 18-55.
- Perley-Robertson GE, Yadav AK, Winogrodzki JL, Stubbs KA, Mark BL & Vocadlo DJ (2016) A fluorescent transport assay enables studying AmpG permeases involved in peptidoglycan recycling and antibiotic resistance. *ACS chemical biology*.
- Perron K, Caille O, Rossier C, Van Delden C, Dumas JL & Kohler T (2004) CzcR-CzcS, a two-component system involved in heavy metal and carbapenem resistance in *Pseudomonas aeruginosa*. *The Journal of biological chemistry* **279**: 8761-8768.
- Pesci EC, Pearson JP, Seed PC & Iglewski BH (1997) Regulation of *las* and *rhl* quorum sensing in *Pseudomonas aeruginosa*. *Journal of bacteriology* **179**: 3127-3132.
- Pesci EC, Milbank JB, Pearson JP, McKnight S, Kende AS, Greenberg EP & Iglewski BH (1999) Quinolone signaling in the cell-to-cell communication system of *Pseudomonas aeruginosa*. *Proceedings of the National Academy of Sciences of the United States of America* **96**: 11229-11234.
- Pier GB (2007) *Pseudomonas aeruginosa* lipopolysaccharide: a major virulence factor, initiator of inflammation and target for effective immunity. *International journal of medical microbiology : IJMM* **297**: 277-295.
- Pittet D, Harbarth S, Ruef C, *et al.* (1999) Prevalence and risk factors for nosocomial infections in four university hospitals in Switzerland. *Infection control and hospital epidemiology* **20**: 37-42.
- Plumbridge J (1995) Co-ordinated regulation of amino sugar biosynthesis and degradation: the NagC repressor acts as both an activator and a repressor for the transcription of the *glmUS* operon and requires two separated NagC binding sites. *The EMBO journal* **14**: 3958-3965.
- Plumbridge J (2009) An alternative route for recycling of N-acetylglucosamine from peptidoglycan involves the N-acetylglucosamine phosphotransferase system in *Escherichia coli*. *Journal of bacteriology* **191**: 5641-5647.
- Poirel L, Naas T & Nordmann P (2010) Diversity, epidemiology, and genetics of class D beta-lactamases. *Antimicrobial agents and chemotherapy* **54**: 24-38.

- Poirel L, Le Thomas I, Naas T, Karim A & Nordmann P (2000) Biochemical sequence analyses of GES-1, a novel class A extended-spectrum beta-lactamase, and the class 1 integron In52 from *Klebsiella pneumoniae*. *Antimicrobial agents and chemotherapy* **44**: 622-632.
- Poirel L, Naas T, Nicolas D, Collet L, Bellais S, Cavallo JD & Nordmann P (2000) Characterization of VIM-2, a carbapenem-hydrolyzing metallo-beta-lactamase and its plasmid- and integron-borne gene from a *Pseudomonas aeruginosa* clinical isolate in France. *Antimicrobial agents and chemotherapy* **44**: 891-897.
- Pomorski T & Menon AK (2006) Lipid flippases and their biological functions. *Cellular and molecular life sciences : CMLS* **63**: 2908-2921.
- Poole K (2000) Efflux-mediated resistance to fluoroquinolones in Gram-negative bacteria. *Antimicrobial agents and chemotherapy* **44**: 2233-2241.
- Poole K (2011) *Pseudomonas aeruginosa*: resistance to the max. *Frontiers in microbiology* **2**: 65.
- Poole K, Krebes K, McNally C & Neshat S (1993) Multiple antibiotic resistance in *Pseudomonas aeruginosa*: evidence for involvement of an efflux operon. *Journal of bacteriology* **175**: 7363-7372.
- Poole K, Tetro K, Zhao Q, Neshat S, Heinrichs DE & Bianco N (1996) Expression of the multidrug resistance operon *mexA-mexB-oprM* in *Pseudomonas aeruginosa*: *mexR* encodes a regulator of operon expression. *Antimicrobial agents and chemotherapy* **40**: 2021-2028.
- Poole K, Gotoh N, Tsujimoto H, *et al.* (1996) Overexpression of the *mexC-mexD-oprJ* efflux operon in *nfxB*-type multidrug-resistant strains of *Pseudomonas aeruginosa*. *Molecular microbiology* **21**: 713-724.
- Potvin E, Lehoux DE, Kukavica-Ibrulj I, Richard KL, Sanschagrin F, Lau GW & Levesque RC (2003) In vivo functional genomics of *Pseudomonas aeruginosa* for high-throughput screening of new virulence factors and antibacterial targets. *Environmental microbiology* **5**: 1294-1308.
- Preston MJ, Seed PC, Toder DS, *et al.* (1997) Contribution of proteases and LasR to the virulence of *Pseudomonas aeruginosa* during corneal infections. *Infection and immunity* **65**: 3086-3090.
- Priyadarshini R, de Pedro MA & Young KD (2007) Role of peptidoglycan amidases in the development and morphology of the division septum in *Escherichia coli*. *Journal of bacteriology* **189**: 5334-5347.
- Proenca R, Niu WW, Cacalano G & Prince A (1993) The *Pseudomonas cepacia* 249 chromosomal penicillinase is a member of the AmpC family of chromosomal beta-lactamases. *Antimicrobial agents and chemotherapy* **37**: 667-674.
- Qiao Y, Lebar MD, Schirner K, Schaefer K, Tsukamoto H, Kahne D & Walker S (2014) Detection of lipid-linked peptidoglycan precursors by exploiting an unexpected transpeptidase reaction. *Journal of the American Chemical Society* **136**: 14678-14681.
- Quintela JC, Caparros M & de Pedro MA (1995) Variability of peptidoglycan structural parameters in Gram-negative bacteria. *FEMS microbiology letters* **125**: 95-100.

- Ramirez MS & Tolmasky ME (2010) Aminoglycoside modifying enzymes. *Drug resistance updates : reviews and commentaries in antimicrobial and anticancer chemotherapy* **13**: 151-171.
- Ramos-Aires J, Plesiat P, Kocjancic-Curty L & Kohler T (2004) Selection of an antibiotic-hypersusceptible mutant of *Pseudomonas aeruginosa*: identification of the GImR transcriptional regulator. *Antimicrobial agents and chemotherapy* **48**: 843-851.
- Ramphal R, McNiece MT & Polack FM (1981) Adherence of *Pseudomonas aeruginosa* to the injured cornea: a step in the pathogenesis of corneal infections. *Annals of ophthalmology* **13**: 421-425.
- Ramsey DM & Wozniak DJ (2005) Understanding the control of *Pseudomonas aeruginosa* alginate synthesis and the prospects for management of chronic infections in cystic fibrosis. *Molecular microbiology* **56**: 309-322.
- Rangel SM, Diaz MH, Knoten CA, Zhang A & Hauser AR (2015) The role of ExoS in dissemination of *Pseudomonas aeruginosa* during pneumonia. *PLoS pathogens* **11**: e1004945.
- Rashid MH & Kornberg A (2000) Inorganic polyphosphate is needed for swimming, swarming, and twitching motilities of *Pseudomonas aeruginosa*. *Proceedings of the National Academy of Sciences of the United States of America* **97**: 4885-4890.
- Rayner RJ, Hiller EJ, Ispahani P & Baker M (1990) *Haemophilus* infection in cystic fibrosis. *Archives of disease in childhood* **65**: 255-258.
- Read RC, Roberts P, Munro N, *et al.* (1992) Effect of *Pseudomonas aeruginosa* rhamnolipids on mucociliary transport and ciliary beating. *Journal of applied physiology* **72**: 2271-2277.
- Reimann C, Beyeler M, Latifi A, Winteler H, Foglino M, Lazdunski A & Haas D (1997) The global activator GacA of *Pseudomonas aeruginosa* PAO positively controls the production of the autoinducer N-butyryl-homoserine lactone and the formation of the virulence factors pyocyanin, cyanide, and lipase. *Molecular microbiology* **24**: 309-319.
- Reith J & Mayer C (2011) Peptidoglycan turnover and recycling in Gram-positive bacteria. *Applied microbiology and biotechnology* **92**: 1-11.
- Remminghorst U & Rehm BH (2006) Bacterial alginates: from biosynthesis to applications. *Biotechnology letters* **28**: 1701-1712.
- Reyes EA, Bale MJ, Cannon WH & Matsen JM (1981) Identification of *Pseudomonas aeruginosa* by pyocyanin production on Tech agar. *Journal of clinical microbiology* **13**: 456-458.
- Rice LB (2008) Federal funding for the study of antimicrobial resistance in nosocomial pathogens: no ESKAPE. *The Journal of infectious diseases* **197**: 1079-1081.
- Richmond MH & Sykes RB (1973) The beta-lactamases of Gram-negative bacteria and their possible physiological role. *Advances in microbial physiology* **9**: 31-88.
- Rietsch A, Vallet-Gely I, Dove SL & Mekalanos JJ (2005) ExsE, a secreted regulator of type III secretion genes in *Pseudomonas aeruginosa*. *Proceedings of the National Academy of Sciences of the United States of America* **102**: 8006-8011.

- Rivera I, Molina R, Lee M, Mobashery S & Hermoso JA (2016) Orthologous and paralogous AmpD peptidoglycan amidases from Gram-negative bacteria. *Microbial drug resistance*.
- Robicsek A, Jacoby GA & Hooper DC (2006) The worldwide emergence of plasmid-mediated quinolone resistance. *The Lancet. Infectious diseases* **6**: 629-640.
- Romeis T & Holtje JV (1994) Penicillin-binding protein 7/8 of *Escherichia coli* is a DD-endopeptidase. *European journal of biochemistry / FEBS* **224**: 597-604.
- Romeis T, Vollmer W & Holtje JV (1993) Characterization of three different lytic transglycosylases in *Escherichia coli*. *FEMS microbiology letters* **111**: 141-146.
- Ropy A, Cabot G, Sanchez-Diener I, Aguilera C, Moya B, Ayala JA & Oliver A (2015) Role of *Pseudomonas aeruginosa* low-molecular-mass penicillin-binding proteins in AmpC expression, beta-lactam resistance, and peptidoglycan structure. *Antimicrobial agents and chemotherapy* **59**: 3925-3934.
- Rose HD (1968) Chronic *Pseudomonas aeruginosa* pneumonia in a normal adult. Report of a case. *Diseases of the chest* **53**: 643-648.
- Ruiz N (2008) Bioinformatics identification of MurJ (MviN) as the peptidoglycan lipid II flippase in *Escherichia coli*. *Proceedings of the National Academy of Sciences of the United States of America* **105**: 15553-15557.
- Ruiz N (2015) Lipid flippases for bacterial peptidoglycan biosynthesis. *Lipid insights* **8**: 21-31.
- Ryder C, Byrd M & Wozniak DJ (2007) Role of polysaccharides in *Pseudomonas aeruginosa* biofilm development. *Current opinion in microbiology* **10**: 644-648.
- Sacha P, Wieczorek P, Hauschild T, Zorawski M, Olszanska D & Tryniszewska E (2008) Metallo-beta-lactamases of *Pseudomonas aeruginosa*--a novel mechanism resistance to beta-lactam antibiotics. *Folia histochemica et cytobiologica* **46**: 137-142.
- Sadikot RT, Blackwell TS, Christman JW & Prince AS (2005) Pathogen-host interactions in *Pseudomonas aeruginosa* pneumonia. *American journal of respiratory and critical care medicine* **171**: 1209-1223.
- Saliba AM, Nascimento DO, Silva MC, et al. (2005) Eicosanoid-mediated proinflammatory activity of *Pseudomonas aeruginosa* ExoU. *Cellular microbiology* **7**: 1811-1822.
- Salton MR (1953) Studies of the bacterial cell wall. IV. The composition of the cell walls of some Gram-positive and Gram-negative bacteria. *Biochimica et biophysica acta* **10**: 512-523.
- Samonis G, Maraki S, Karageorgopoulos DE, Vouloumanou EK & Falagas ME (2012) Synergy of fosfomycin with carbapenems, colistin, netilmicin, and tigecycline against multidrug-resistant *Klebsiella pneumoniae*, *Escherichia coli*, and *Pseudomonas aeruginosa* clinical isolates. *European journal of clinical microbiology & infectious diseases : official publication of the European Society of Clinical Microbiology* **31**: 695-701.
- Santos JM, Lobo M, Matos AP, De Pedro MA & Arraiano CM (2002) The gene *bolA* regulates *dacA* (PBP5), *dacC* (PBP6) and *ampC* (AmpC), promoting normal morphology in *Escherichia coli*. *Molecular microbiology* **45**: 1729-1740.

- Sarkar SK, Chowdhury C & Ghosh AS (2010) Deletion of penicillin-binding protein 5 (PBP5) sensitises *Escherichia coli* cells to beta-lactam agents. *International journal of antimicrobial agents* **35**: 244-249.
- Sarkar SK, Dutta M, Chowdhury C, Kumar A & Ghosh AS (2011) PBP5, PBP6 and DacD play different roles in intrinsic beta-lactam resistance of *Escherichia coli*. *Microbiology* **157**: 2702-2707.
- Sauvage E, Kerff F, Terrak M, Ayala JA & Charlier P (2008) The penicillin-binding proteins: structure and role in peptidoglycan biosynthesis. *FEMS microbiology reviews* **32**: 234-258.
- Sawa T, Ohara M, Kurahashi K, *et al.* (1998) In vitro cellular toxicity predicts *Pseudomonas aeruginosa* virulence in lung infections. *Infection and immunity* **66**: 3242-3249.
- Schad PA & Iglewski BH (1988) Nucleotide sequence and expression in *Escherichia coli* of the *Pseudomonas aeruginosa* lasA gene. *Journal of bacteriology* **170**: 2784-2789.
- Scheurwater E, Reid CW & Clarke AJ (2008) Lytic transglycosylases: bacterial space-making autolysins. *The international journal of biochemistry & cell biology* **40**: 586-591.
- Scheurwater EM, Pfeffer JM & Clarke AJ (2007) Production and purification of the bacterial autolysin N-acetylmuramoyl-L-alanine amidase B from *Pseudomonas aeruginosa*. *Protein expression and purification* **56**: 128-137.
- Schiffer G & Holtje JV (1999) Cloning and characterization of PBP 1C, a third member of the multimodular class A penicillin-binding proteins of *Escherichia coli*. *The Journal of biological chemistry* **274**: 32031-32039.
- Schlaman HR, Spaink HP, Okker RJ & Lugtenberg BJ (1989) Subcellular localization of the *nodD* gene product in *Rhizobium leguminosarum*. *Journal of bacteriology* **171**: 4686-4693.
- Schleifer KH & Kandler O (1972) Peptidoglycan types of bacterial cell walls and their taxonomic implications. *Bacteriological reviews* **36**: 407-477.
- Schmidt DM, Hubbard BK & Gerlt JA (2001) Evolution of enzymatic activities in the enolase superfamily: functional assignment of unknown proteins in *Bacillus subtilis* and *Escherichia coli* as L-Ala-D/L-Glu epimerases. *Biochemistry* **40**: 15707-15715.
- Schmidtke AJ & Hanson ND (2008) Role of *ampD* homologs in overproduction of AmpC in clinical isolates of *Pseudomonas aeruginosa*. *Antimicrobial agents and chemotherapy* **52**: 3922-3927.
- Schneper L. MN, Mathee K. (2012) Anti-quorum sensing, anti-bacterial and immunomodulatory properties of *Panax ginseng*. ed.^eds.), p.^pp. Global Science Books.
- Schroeder U, Henrich B, Fink J & Plapp R (1994) Peptidase D of *Escherichia coli* K-12, a metallopeptidase of low substrate specificity. *FEMS microbiology letters* **123**: 153-159.
- Schweizer HP (2003) Efflux as a mechanism of resistance to antimicrobials in *Pseudomonas aeruginosa* and related bacteria: unanswered questions. *Genetics and molecular research : GMR* **2**: 48-62.

- Secher I, Hermes I, Pre S, Carreau F & Bahuet F (2005) [Surgical wound infections due to *Pseudomonas aeruginosa* in orthopedic surgery]. *Medecine et maladies infectieuses* **35**: 149-154.
- Seoane A, Francia MV & Garcia Lobo JM (1992) Nucleotide sequence of the *ampC-ampR* region from the chromosome of *Yersinia enterocolitica*. *Antimicrobial agents and chemotherapy* **36**: 1049-1052.
- Seyfried PL & Fraser DJ (1978) *Pseudomonas aeruginosa* in swimming pools related to the incidence of otitis externa infection. *Health laboratory science* **15**: 50-57.
- Shah IM, Laaberki MH, Popham DL & Dworkin J (2008) A eukaryotic-like Ser/Thr kinase signals bacteria to exit dormancy in response to peptidoglycan fragments. *Cell* **135**: 486-496.
- Sham LT, Butler EK, Lebar MD, Kahne D, Bernhardt TG & Ruiz N (2014) Bacterial cell wall. MurJ is the flippase of lipid-linked precursors for peptidoglycan biogenesis. *Science* **345**: 220-222.
- Shanks RM, Caiazza NC, Hinsa SM, Toutain CM & O'Toole GA (2006) *Saccharomyces cerevisiae*-based molecular tool kit for manipulation of genes from Gram-negative bacteria. *Appl Environ Microbiol* **72**: 5027-5036.
- Shaw KJ, Rather PN, Hare RS & Miller GH (1993) Molecular genetics of aminoglycoside resistance genes and familial relationships of the aminoglycoside-modifying enzymes. *Microbiological reviews* **57**: 138-163.
- Shigemura K, Arakawa S, Sakai Y, Kinoshita S, Tanaka K & Fujisawa M (2006) Complicated urinary tract infection caused by *Pseudomonas aeruginosa* in a single institution (1999-2003). *International journal of urology : official journal of the Japanese Urological Association* **13**: 538-542.
- Shimkets LJ & Kaiser D (1982) Murein components rescue developmental sporulation of *Myxococcus xanthus*. *Journal of bacteriology* **152**: 462-470.
- Silby MW, Winstanley C, Godfrey SA, Levy SB & Jackson RW (2011) *Pseudomonas* genomes: diverse and adaptable. *FEMS microbiology reviews* **35**: 652-680.
- Silver LL (2011) Challenges of antibacterial discovery. *Clinical microbiology reviews* **24**: 71-109.
- Smith JD, Kumarasiri M, Zhang W, *et al.* (2013) Structural analysis of the role of *Pseudomonas aeruginosa* penicillin-binding protein 5 in beta-lactam resistance. *Antimicrobial agents and chemotherapy* **57**: 3137-3146.
- Smith RS & Iglewski BH (2003) *P. aeruginosa* quorum-sensing systems and virulence. *Current opinion in microbiology* **6**: 56-60.
- Solano C, Echeverez M & Lasa I (2014) Biofilm dispersion and quorum sensing. *Current opinion in microbiology* **18**: 96-104.
- Solomons CC, Cotton EK, Dubois R & Pinney M (1971) The use of buffered L-arginine in the treatment of cystic fibrosis. *Pediatrics* **47**: 384-390.
- Song J, Xie G, Elf PK, Young KD & Jensen RA (1998) Comparative analysis of *Pseudomonas aeruginosa* penicillin-binding protein 7 in the context of its membership in the family of low-molecular-mass PBPs. *Microbiology* **144 (Pt 4)**: 975-983.

- Song Z, Kong KF, Wu H, *et al.* (2010) *Panax ginseng* has anti-infective activity against opportunistic pathogen *Pseudomonas aeruginosa* by inhibiting quorum sensing, a bacterial communication process critical for establishing infection. *Phytomedicine : international journal of phytotherapy and phytopharmacology* **17**: 1040-1046.
- Spratt BG (1977) Properties of the penicillin-binding proteins of *Escherichia coli* K12. *European journal of biochemistry* **72**: 341-352.
- Spratt BG & Strominger JL (1976) Identification of the major penicillin-binding proteins of *Escherichia coli* as D-alanine carboxypeptidase IA. *Journal of bacteriology* **127**: 660-663.
- Srikumar R, Paul CJ & Poole K (2000) Influence of mutations in the *mexR* repressor gene on expression of the MexA-MexB-oprM multidrug efflux system of *Pseudomonas aeruginosa*. *Journal of bacteriology* **182**: 1410-1414.
- Srikumar R, Kon T, Gotoh N & Poole K (1998) Expression of *Pseudomonas aeruginosa* multidrug efflux pumps MexA-MexB-OprM and MexC-MexD-OprJ in a multidrug-sensitive *Escherichia coli* strain. *Antimicrobial agents and chemotherapy* **42**: 65-71.
- Stapper AP, Narasimhan G, Ohman DE, *et al.* (2004) Alginate production affects *Pseudomonas aeruginosa* biofilm development and architecture, but is not essential for biofilm formation. *Journal of medical microbiology* **53**: 679-690.
- Stevens TC, Ochoa CD, Morrow KA, *et al.* (2014) The *Pseudomonas aeruginosa* exoenzyme Y impairs endothelial cell proliferation and vascular repair following lung injury. *American journal of physiology. Lung cellular and molecular physiology* **306**: L915-924.
- Stewart PS (2002) Mechanisms of antibiotic resistance in bacterial biofilms. *International journal of medical microbiology : IJMM* **292**: 107-113.
- Stintzi A, Evans K, Meyer JM & Poole K (1998) Quorum-sensing and siderophore biosynthesis in *Pseudomonas aeruginosa*: *lasR/lasI* mutants exhibit reduced pyoverdine biosynthesis. *FEMS microbiology letters* **166**: 341-345.
- Stover CK, Pham XQ, Erwin AL, *et al.* (2000) Complete genome sequence of *Pseudomonas aeruginosa* PAO1, an opportunistic pathogen. *Nature* **406**: 959-964.
- Strominger JL, Izaki K, Matsushashi M & Tipper DJ (1967) Peptidoglycan transpeptidase and D-alanine carboxypeptidase: penicillin-sensitive enzymatic reactions. *Federation proceedings* **26**: 9-22.
- Stubbs KA, Balcewich M, Mark BL & Vocadlo DJ (2007) Small molecule inhibitors of a glycoside hydrolase attenuate inducible AmpC-mediated beta-lactam resistance. *The Journal of biological chemistry* **282**: 21382-21391.
- Stubbs KA, Scaffidi A, Debowski AW, Mark BL, Stick RV & Vocadlo DJ (2008) Synthesis and use of mechanism-based protein-profiling probes for retaining beta-D-glucosaminidases facilitate identification of *Pseudomonas aeruginosa* NagZ. *Journal of the American Chemical Society* **130**: 327-335.
- Sugawara E, Nestorovich EM, Bezrukov SM & Nikaido H (2006) *Pseudomonas aeruginosa* porin OprF exists in two different conformations. *The Journal of biological chemistry* **281**: 16220-16229.

- Suzuki H, van Heijenoort Y, Tamura T, Mizoguchi J, Hirota Y & van Heijenoort J (1980) In vitro peptidoglycan polymerization catalysed by penicillin binding protein 1b of *Escherichia coli* K-12. *FEBS letters* **110**: 245-249.
- Sykes RB & Matthew M (1976) The beta-lactamases of Gram-negative bacteria and their role in resistance to beta-lactam antibiotics. *The Journal of antimicrobial chemotherapy* **2**: 115-157.
- Tacconelli E, Smith G, Hieke K, Lafuma A & Bastide P (2009) Epidemiology, medical outcomes and costs of catheter-related bloodstream infections in intensive care units of four European countries: literature- and registry-based estimates. *The Journal of hospital infection* **72**: 97-103.
- Takeuchi O & Akira S (2010) Pattern recognition receptors and inflammation. *Cell* **140**: 805-820.
- Talsma SS (2007) Biofilms on medical devices. *Home healthcare nurse* **25**: 589-594.
- Tamura T, Imae Y & Strominger JL (1976) Purification to homogeneity and properties of two D-alanine carboxypeptidases I from *Escherichia coli*. *The Journal of biological chemistry* **251**: 414-423.
- Tamura T, Suzuki H, Nishimura Y, Mizoguchi J & Hirota Y (1980) On the process of cellular division in *Escherichia coli*: isolation and characterization of penicillin-binding proteins 1a, 1b, and 3. *Proceedings of the National Academy of Sciences of the United States of America* **77**: 4499-4503.
- Tan MW, Mahajan-Miklos S & Ausubel FM (1999) Killing of *Caenorhabditis elegans* by *Pseudomonas aeruginosa* used to model mammalian bacterial pathogenesis. *Proceedings of the National Academy of Sciences of the United States of America* **96**: 715-720.
- Tangden T (2014) Combination antibiotic therapy for multidrug-resistant Gram-negative bacteria. *Uppsala journal of medical sciences* **119**: 149-153.
- Tavares IM, Jolly L, Pompeo F, Leitao JH, Fialho AM, Sa-Correia I & Mengin-Lecreux D (2000) Identification of the *Pseudomonas aeruginosa glmM* gene, encoding phosphoglucosamine mutase. *Journal of bacteriology* **182**: 4453-4457.
- Teixeira B, Rodolfo H, Carreno N, Guzman M, Salazar E & De Donato M (2016) Aminoglycoside resistance genes in *Pseudomonas aeruginosa* isolates from Cumana, Venezuela. *Revista do Instituto de Medicina Tropical de Sao Paulo* **58**: 13.
- Templin MF, Ursinus A & Holtje JV (1999) A defect in cell wall recycling triggers autolysis during the stationary growth phase of *Escherichia coli*. *The EMBO journal* **18**: 4108-4117.
- Terrak M, Ghosh TK, van Heijenoort J, *et al.* (1999) The catalytic, glycosyl transferase and acyl transferase modules of the cell wall peptidoglycan-polymerizing penicillin-binding protein 1b of *Escherichia coli*. *Molecular microbiology* **34**: 350-364.
- Tipper DJ & Strominger JL (1965) Mechanism of action of penicillins: a proposal based on their structural similarity to acyl-D-alanyl-D-alanine. *Proceedings of the National Academy of Sciences of the United States of America* **54**: 1133-1141.
- Toleman MA, Simm AM, Murphy TA, Gales AC, Biedenbach DJ, Jones RN & Walsh TR (2002) Molecular characterization of SPM-1, a novel metallo-beta-lactamase isolated in

- Latin America: report from the SENTRY antimicrobial surveillance programme. *The Journal of antimicrobial chemotherapy* **50**: 673-679.
- Tolg M, Schmidt H, Schierl R, Datz M & Martin HH (1993) Dependence of induction of enterobacterial AmpC beta-lactamase on cell-wall peptidoglycan, as demonstrated in *Proteus mirabilis* and its wall-less protoplast L-form. *Journal of general microbiology* **139**: 2715-2722.
- Tomioka S, Nikaido T, Miyakawa T & Matsushashi M (1983) Mutation of the N-acetylmuramyl-L-alanine amidase gene of *Escherichia coli* K-12. *Journal of bacteriology* **156**: 463-465.
- Tong BC & Barbul A (2004) Cellular and physiological effects of arginine. *Mini reviews in medicinal chemistry* **4**: 823-832.
- Torrens G, Perez-Gallego M, Moya B, *et al.* (2017) Targeting the permeability barrier and peptidoglycan recycling pathways to disarm *Pseudomonas aeruginosa* against the innate immune system. *PloS one* **12**: e0181932.
- Toutain CM, Zegans ME & O'Toole GA (2005) Evidence for two flagellar stators and their role in the motility of *Pseudomonas aeruginosa*. *Journal of bacteriology* **187**: 771-777.
- Tran JH & Jacoby GA (2002) Mechanism of plasmid-mediated quinolone resistance. *Proceedings of the National Academy of Sciences of the United States of America* **99**: 5638-5642.
- Trias J & Nikaido H (1990) Protein D2 channel of the *Pseudomonas aeruginosa* outer membrane has a binding site for basic amino acids and peptides. *The Journal of biological chemistry* **265**: 15680-15684.
- Tsui HC, Zhao G, Feng G, Leung HC & Winkler ME (1994) The *mutL* repair gene of *Escherichia coli* K-12 forms a superoperon with a gene encoding a new cell-wall amidase. *Molecular microbiology* **11**: 189-202.
- Tummler B, Bosshammer J, Breitenstein S, *et al.* (1997) Infections with *Pseudomonas aeruginosa* in patients with cystic fibrosis. *Behring Institute Mitteilungen* 249-255.
- Tuomanen E, Lindquist S, Sande S, Galleni M, Light K, Gage D & Normark S (1991) Coordinate regulation of beta-lactamase induction and peptidoglycan composition by the *amp* operon. *Science* **251**: 201-204.
- Typas A, Banzhaf M, Gross CA & Vollmer W (2011) From the regulation of peptidoglycan synthesis to bacterial growth and morphology. *Nature reviews. Microbiology* **10**: 123-136.
- Tzouveleakis LS & Bonomo RA (1999) SHV-type beta-lactamases. *Current pharmaceutical design* **5**: 847-864.
- Uehara T & Park JT (2003) Identification of MpaA, an amidase in *Escherichia coli* that hydrolyzes the gamma-D-glutamyl-meso-diaminopimelate bond in murein peptides. *Journal of bacteriology* **185**: 679-682.
- Uehara T & Park JT (2004) The N-acetyl-D-glucosamine kinase of *Escherichia coli* and its role in murein recycling. *Journal of bacteriology* **186**: 7273-7279.

- Uehara T & Park JT (2007) An anhydro-N-acetylmuramyl-L-alanine amidase with broad specificity tethered to the outer membrane of *Escherichia coli*. *Journal of bacteriology* **189**: 5634-5641.
- Uehara T, Dinh T & Bernhardt TG (2009) LytM-domain factors are required for daughter cell separation and rapid ampicillin-induced lysis in *Escherichia coli*. *Journal of bacteriology* **191**: 5094-5107.
- Uehara T, Parzych KR, Dinh T & Bernhardt TG (2010) Daughter cell separation is controlled by cytokinetic ring-activated cell wall hydrolysis. *The EMBO journal* **29**: 1412-1422.
- Uehara T, Suefuji K, Jaeger T, Mayer C & Park JT (2006) MurQ etherase is required by *Escherichia coli* in order to metabolize anhydro-N-acetylmuramic acid obtained either from the environment or from its own cell wall. *Journal of bacteriology* **188**: 1660-1662.
- Uehara T, Suefuji K, Valbuena N, Meehan B, Donegan M & Park JT (2005) Recycling of the anhydro-N-acetylmuramic acid derived from cell wall murein involves a two-step conversion to N-acetylglucosamine-phosphate. *Journal of bacteriology* **187**: 3643-3649.
- Ueno T, Oosawa K & Aizawa S (1992) M ring, S ring and proximal rod of the flagellar basal body of *Salmonella typhimurium* are composed of subunits of a single protein, FliF. *Journal of molecular biology* **227**: 672-677.
- Uwate M, Ichise YK, Shirai A, Omasa T, Nakae T & Maseda H (2013) Two routes of MexS-MexT-mediated regulation of MexEF-OprN and MexAB-OprM efflux pump expression in *Pseudomonas aeruginosa*. *Microbiology and immunology* **57**: 263-272.
- Vadlamani G, Thomas MD, Patel TR, *et al.* (2015) The beta-lactamase gene regulator AmpR is a tetramer that recognizes and binds the D-Ala-D-Ala motif of its repressor UDP-N-acetylmuramic acid (MurNAc)-pentapeptide. *The Journal of biological chemistry* **290**: 2630-2643.
- Valderrey AD, Pozuelo MJ, Jimenez PA, Macia MD, Oliver A & Rotger R (2010) Chronic colonization by *Pseudomonas aeruginosa* of patients with obstructive lung diseases: cystic fibrosis, bronchiectasis, and chronic obstructive pulmonary disease. *Diagnostic microbiology and infectious disease* **68**: 20-27.
- Vallis AJ, Yahr TL, Barbieri JT & Frank DW (1999) Regulation of ExoS production and secretion by *Pseudomonas aeruginosa* in response to tissue culture conditions. *Infection and immunity* **67**: 914-920.
- van der Linden MP, de Haan L, Hoyer MA & Keck W (1992) Possible role of *Escherichia coli* penicillin-binding protein 6 in stabilization of stationary-phase peptidoglycan. *Journal of bacteriology* **174**: 7572-7578.
- van Heijenoort J (2007) Lipid intermediates in the biosynthesis of bacterial peptidoglycan. *Microbiology and molecular biology reviews* : *MMBR* **71**: 620-635.
- van Heijenoort J (2011) Peptidoglycan hydrolases of *Escherichia coli*. *Microbiology and molecular biology reviews* : *MMBR* **75**: 636-663.
- van Heijenoort J, Parquet C, Flouret B & van Heijenoort Y (1975) Envelope-bound N-acetylmuramyl-L-alanine amidase of *Escherichia coli* K 12. Purification and properties of the enzyme. *European journal of biochemistry* **58**: 611-619.

- Van Heijenoort Y & Van Heijenoort J (1971) Study of the N-acetylmuramyl-L-alanine amidase activity in *Escherichia coli*. *FEBS letters* **15**: 137-141.
- Vasil ML (1986) *Pseudomonas aeruginosa*: biology, mechanisms of virulence, epidemiology. *The Journal of pediatrics* **108**: 800-805.
- Venter H, Mowla R, Ohene-Agyei T & Ma S (2015) RND-type drug efflux pumps from Gram-negative bacteria: molecular mechanism and inhibition. *Frontiers in microbiology* **6**: 377.
- Vento S, Cainelli F & Temesgen Z (2008) Lung infections after cancer chemotherapy. *The Lancet. Oncology* **9**: 982-992.
- Visca P, Imperi F & Lamont IL (2007) Pyoverdine siderophores: from biogenesis to biosignificance. *Trends in microbiology* **15**: 22-30.
- Vogler AP, Homma M, Irikura VM & Macnab RM (1991) *Salmonella typhimurium* mutants defective in flagellar filament regrowth and sequence similarity of Flil to F0F1, vacuolar, and archaeobacterial ATPase subunits. *Journal of bacteriology* **173**: 3564-3572.
- Vollmer W & Holtje JV (2004) The architecture of the murein (peptidoglycan) in Gram-negative bacteria: vertical scaffold or horizontal layer(s)? *Journal of bacteriology* **186**: 5978-5987.
- Vollmer W, Blanot D & de Pedro MA (2008) Peptidoglycan structure and architecture. *FEMS microbiology reviews* **32**: 149-167.
- Vollmer W, Joris B, Charlier P & Foster S (2008) Bacterial peptidoglycan (murein) hydrolases. *FEMS microbiology reviews* **32**: 259-286.
- Votsch W & Templin MF (2000) Characterization of a beta-N-acetylglucosaminidase of *Escherichia coli* and elucidation of its role in muropeptide recycling and beta-lactamase induction. *The Journal of biological chemistry* **275**: 39032-39038.
- Walker JM (1994) The bicinchoninic acid (BCA) assay for protein quantitation. *Methods in molecular biology* **32**: 5-8.
- Walther-Rasmussen J & Hoiby N (2002) Plasmid-borne AmpC beta-lactamases. *Canadian journal of microbiology* **48**: 479-493.
- Watanabe M, Iyobe S, Inoue M & Mitsuhashi S (1991) Transferable imipenem resistance in *Pseudomonas aeruginosa*. *Antimicrobial agents and chemotherapy* **35**: 147-151.
- Waters CM & Bassler BL (2005) Quorum sensing: cell-to-cell communication in bacteria. *Annu. Rev. Cell Dev. Biol.* **21**: 319-346.
- Waters V & Smyth A (2015) Cystic fibrosis microbiology: Advances in antimicrobial therapy. *Journal of cystic fibrosis : official journal of the European Cystic Fibrosis Society* **14**: 551-560.
- Watt SR & Clarke AJ (1994) Initial characterization of two extracellular autolysins from *Pseudomonas aeruginosa* PAO1. *Journal of bacteriology* **176**: 4784-4789.
- Weidel W & Pelzer H (1964) Bagshaped macromolecules--a new outlook on bacterial cell walls. *Advances in enzymology and related subjects of biochemistry* **26**: 193-232.

- Weldhagen GF, Poirel L & Nordmann P (2003) Ambler class A extended-spectrum beta-lactamases in *Pseudomonas aeruginosa*: novel developments and clinical impact. *Antimicrobial agents and chemotherapy* **47**: 2385-2392.
- Werner V, Sanders CC, Sanders WE, Jr. & Goering RV (1985) Role of beta-lactamases and outer membrane proteins in multiple beta-lactam resistance of *Enterobacter cloacae*. *Antimicrobial agents and chemotherapy* **27**: 455-459.
- West SE, Zeng L, Lee BL, *et al.* (2002) Respiratory infections with *Pseudomonas aeruginosa* in children with cystic fibrosis: early detection by serology and assessment of risk factors. *JAMA* **287**: 2958-2967.
- Westfall LW, Carty NL, Layland N, Kuan P, Colmer-Hamood JA & Hamood AN (2006) *mvaT* mutation modifies the expression of the *Pseudomonas aeruginosa* multidrug efflux operon *mexEF-oprN*. *FEMS microbiology letters* **255**: 247-254.
- Whatmore AM & Reed RH (1990) Determination of turgor pressure in *Bacillus subtilis*: a possible role for K⁺ in turgor regulation. *Journal of general microbiology* **136**: 2521-2526.
- White RJ & Pasternak CA (1967) The purification and properties of N-acetylglucosamine 6-phosphate deacetylase from *Escherichia coli*. *The Biochemical journal* **105**: 121-125.
- Whiteley M, Lee KM & Greenberg EP (1999) Identification of genes controlled by quorum sensing in *Pseudomonas aeruginosa*. *Proceedings of the National Academy of Sciences of the United States of America* **96**: 13904-13909.
- Wiedemann B, Pfeifle D, Wiegand I & Janas E (1998) Beta-lactamase induction and cell wall recycling in Gram-negative bacteria. *Drug resistance updates : reviews and commentaries in antimicrobial and anticancer chemotherapy* **1**: 223-226.
- Winsor GL, Griffiths EJ, Lo R, Dhillon BK, Shay JA & Brinkman FS (2016) Enhanced annotations and features for comparing thousands of *Pseudomonas* genomes in the *Pseudomonas* genome database. *Nucleic acids research* **44**: D646-653.
- Winstanley C, O'Brien S & Brockhurst MA (2016) *Pseudomonas aeruginosa* evolutionary adaptation and diversification in cystic fibrosis chronic lung infections. *Trends in microbiology* **24**: 327-337.
- Wise EM, Jr. & Park JT (1965) Penicillin: its basic site of action as an inhibitor of a peptide cross-linking reaction in cell wall mucopeptide synthesis. *Proceedings of the National Academy of Sciences of the United States of America* **54**: 75-81.
- Wolf AJ & Underhill DM (2018) Peptidoglycan recognition by the innate immune system. *Nature reviews. Immunology* **18**: 243-254.
- Wolfert MA, Roychowdhury A & Boons GJ (2007) Modification of the structure of peptidoglycan is a strategy to avoid detection by nucleotide-binding oligomerization domain protein 1. *Infection and immunity* **75**: 706-713.
- Wolfert MA, Murray TF, Boons GJ & Moore JN (2002) The origin of the synergistic effect of muramyl dipeptide with endotoxin and peptidoglycan. *The Journal of biological chemistry* **277**: 39179-39186.
- Woodhams KL, Chan JM, Lenz JD, Hackett KT & Dillard JP (2013) Peptidoglycan fragment release from *Neisseria meningitidis*. *Infection and immunity* **81**: 3490-3498.

- World Health Organization (2017) WHO publishes list of bacteria for which new antibiotics are urgently needed.
- Wu BY, Peng CT, Tsai CH & Chiu HH (1999) Community-acquired *Pseudomonas aeruginosa* bacteremia and sepsis in previously healthy infants. *Acta paediatrica Taiwanica = Taiwan er ke yi xue hui za zhi* **40**: 233-236.
- Wu H, Lee B, Yang L, *et al.* (2011) Effects of ginseng on *Pseudomonas aeruginosa* motility and biofilm formation. *FEMS immunology and medical microbiology* **62**: 49-56.
- Wu H, Lee B, Yang L, *et al.* (2011) Effects of ginseng on *Pseudomonas aeruginosa* motility and biofilm formation. *FEMS Immunology & Medical Microbiology* **62**: 49-56.
- Yahr TL & Frank DW (1994) Transcriptional organization of the trans-regulatory locus which controls exoenzyme S synthesis in *Pseudomonas aeruginosa*. *Journal of bacteriology* **176**: 3832-3838.
- Yahr TL & Greenberg EP (2004) The genetic basis for the commitment to chronic versus acute infection in *Pseudomonas aeruginosa*. *Molecular cell* **16**: 497-498.
- Yakhnina AA, McManus HR & Bernhardt TG (2015) The cell wall amidase AmiB is essential for *Pseudomonas aeruginosa* cell division, drug resistance and viability. *Molecular microbiology* **97**: 957-973.
- Yamagishi J, Yoshida H, Yamayoshi M & Nakamura S (1986) Nalidixic acid-resistant mutations of the *gyrB* gene of *Escherichia coli*. *Molecular & general genetics : MGG* **204**: 367-373.
- Yamagishi J, Furutani Y, Inoue S, Ohue T, Nakamura S & Shimizu M (1981) New nalidixic acid resistance mutations related to deoxyribonucleic acid gyrase activity. *Journal of bacteriology* **148**: 450-458.
- Yamaguchi T, Blazquez B, Heseck D, *et al.* (2012) Inhibitors for bacterial cell-wall recycling. *ACS medicinal chemistry letters* **3**: 238-242.
- Yang TC, Chen TF, Tsai JJ & Hu RM (2013) AmpG is required for BlaXc beta-lactamase expression in *Xanthomonas campestris* pv. *campestris* str. 17. *FEMS microbiology letters* **340**: 101-108.
- Yang Y & Bush K (1995) Oxacillin hydrolysis by the LCR-1 beta-lactamase. *Antimicrobial agents and chemotherapy* **39**: 1209.
- Yem DW & Wu HC (1976) Purification and properties of beta-N-acetylglucosaminidase from *Escherichia coli*. *Journal of bacteriology* **125**: 324-331.
- Yem DW & Wu HC (1976) Isolation of *Escherichia coli* K-12 mutants with altered level of beta-N-acetylglucosaminidase. *Journal of bacteriology* **125**: 372-373.
- Yeo SG, Park DC, Hong SM, Cha CI & Kim MG (2007) Bacteriology of chronic suppurative otitis media--a multicenter study. *Acta oto-laryngologica* **127**: 1062-1067.
- Yildirim S, Nursal TZ, Tarim A, *et al.* (2005) Bacteriological profile and antibiotic resistance: comparison of findings in a burn intensive care unit, other intensive care units, and the hospital services unit of a single center. *The Journal of burn care & rehabilitation* **26**: 488-492.
- Yoshimura F & Nikaido H (1982) Permeability of *Pseudomonas aeruginosa* outer membrane to hydrophilic solutes. *Journal of bacteriology* **152**: 636-642.

- Yoshimura F, Zalman LS & Nikaido H (1983) Purification and properties of *Pseudomonas aeruginosa* porin. *The Journal of biological chemistry* **258**: 2308-2314.
- Yum HK, Park IN, Shin BM & Choi SJ (2014) Recurrent *Pseudomonas aeruginosa* infection in chronic lung diseases: relapse or reinfection? *Tuberculosis and respiratory diseases* **77**: 172-177.
- Yunck R, Cho H & Bernhardt TG (2016) Identification of MltG as a potential terminase for peptidoglycan polymerization in bacteria. *Molecular microbiology* **99**: 700-718.
- Zamorano L, Moya B, Juan C & Oliver A (2010) Differential beta-lactam resistance response driven by *ampD* or *dacB* (PBP4) inactivation in genetically diverse *Pseudomonas aeruginosa* strains. *The Journal of antimicrobial chemotherapy* **65**: 1540-1542.
- Zamorano L, Moya B, Juan C, Mulet X, Blazquez J & Oliver A (2014) The *Pseudomonas aeruginosa* CreBC two-component system plays a major role in the response to beta-lactams, fitness, biofilm growth, and global regulation. *Antimicrobial agents and chemotherapy* **58**: 5084-5095.
- Zamorano L, Reeve TM, Juan C, *et al.* (2011) AmpG inactivation restores susceptibility of pan-beta-lactam-resistant *Pseudomonas aeruginosa* clinical strains. *Antimicrobial agents and chemotherapy* **55**: 1990-1996.
- Zamorano L, Reeve TM, Deng L, *et al.* (2010) NagZ inactivation prevents and reverts beta-lactam resistance, driven by AmpD and PBP 4 mutations, in *Pseudomonas aeruginosa*. *Antimicrobial agents and chemotherapy* **54**: 3557-3563.
- Zawadzke LE, Bugg TD & Walsh CT (1991) Existence of two D-alanine:D-alanine ligases in *Escherichia coli*: cloning and sequencing of the *ddlA* gene and purification and characterization of the DdlA and DdlB enzymes. *Biochemistry* **30**: 1673-1682.
- Zemelman R, Norambuena R, Vergara L & Gacitua R (1987) Beta-lactam antibiotics: grouping according to their chemical structure and bacteriological properties. *Revista medica de Chile* **115**: 983-991.
- Zeng X & Lin J (2013) Beta-lactamase induction and cell wall metabolism in Gram-negative bacteria. *Frontiers in microbiology* **4**: 128.
- Zhang JH, Chung TD & Oldenburg KR (1999) A simple statistical parameter for use in evaluation and validation of high throughput screening assays. *Journal of biomolecular screening* **4**: 67-73.
- Zhang W, Lee M, Heseck D, Lastochkin E, Boggess B & Mobashery S (2013) Reactions of the three AmpD enzymes of *Pseudomonas aeruginosa*. *Journal of the American Chemical Society* **135**: 4950-4953.
- Zhang W, Lee M, Heseck D, Lastochkin E, Boggess B & Mobashery S (2013) Reactions of the three AmpD enzymes of *Pseudomonas aeruginosa*. *Journal of the American Chemical Society*.
- Zhang Y, Bao Q, Gagnon LA, Huletsky A, Oliver A, Jin S & Langae T (2010) *ampG* gene of *Pseudomonas aeruginosa* and its role in beta-lactamase expression. *Antimicrobial agents and chemotherapy* **54**: 4772-4779.
- Zhao WH & Hu ZQ (2010) Beta-lactamases identified in clinical isolates of *Pseudomonas aeruginosa*. *Critical reviews in microbiology* **36**: 245-258.

Zincke D, Balasubramanian D, Silver LL & Mathee K (2015) Characterization of a carbapenem-hydrolyzing enzyme, PoxB, in *Pseudomonas aeruginosa* PAO1. *Antimicrobial agents and chemotherapy* **60**: 936-945.

Zincke D, Balasubramanian D, Silver LL & Mathee K (2016) Characterization of a carbapenem-hydrolyzing Enzyme, PoxB, in *Pseudomonas aeruginosa* PAO1. *Antimicrobial agents and chemotherapy* **60**: 936-945.

VITA

SUPURNA DHAR

2004-2007	Bachelor of Sciences (BSc.) Osmania University Hyderabad, India
2007-2010	Master of Sciences (MSc) Manipal University Karnataka, India
2012-2018	PhD Candidate, HWCOR, Florida International University Miami, Florida

PUBLICATIONS AND PRESENTATIONS

1. Lee M*, Dhar S*, De Benedetti S, Heseck D, Boggess B, Blazquez B, Mathee K, Mobashery S. "Muropeptides in *Pseudomonas aeruginosa* and their Role as Elicitors of β -Lactam-Antibiotic Resistance." *Angewandte Chemie International Edition* 55.24 (2016): 6882-6886. Original Article (* Equal Contribution).
2. Pawitwar S, Dhar S, Tiwari S, Ojha CR, Lapierre J, Martins K, Rodzinski A, Parira T, Paudel I, Li JJ, Dutta RK, Silva MR, Kaushik A, El-Hage N. "Overview on the Current Status of Zika Virus Pathogenesis and Animal Related Research". *J Neuroimmune Pharmacol* (2017). Doi:10.1007/s11481-017-9743-8. Original Article.
3. Dhar S, Kumari H, Balasubramanian D, Mathee K. "Cell-wall recycling and synthesis in *Escherichia coli* and *Pseudomonas aeruginosa*- their role in development of antibiotic resistance." *Journal of Medical Microbiology*. Nov 29, 2017.
4. Dhar S, Lee M, Heseck D, Boggess W, Kumari H, Schenepfer L, Mathee K, Mobashery S (2015). Identification of AmpR Effectors in *Pseudomonas aeruginosa* Regulating β -Lactam Resistance. 10th Cold Spring Harbor meeting on Microbial Pathogenesis and Host Response, Cold Spring Harbor, NY.
5. Dhar S, Kumari H, Mathee K (2018). Elucidating the role of FlgJ in *Pseudomonas aeruginosa*. ASM MICROBE 2018, Atlanta, GA.
6. Dhar S, Lee M, Benedetti De S, Heseck D, Boggess W, Kumari H, Schenepfer L, Mobashery S, Mathee K (2017). Characterization of muramyl peptides

regulating *P. aeruginosa* AmpR. American Society of Microbiology ASM. 103rd Southeastern Branch Annual Meeting, St. Petersburg, FL.

7. Dhar S, Kumari H, Mathee K (2018). Elucidating the role of PA1085 in *Pseudomonas aeruginosa*. FIU 20th Biomedical and Comparative Immunology Symposium (Awarded 1st place).