



Locust  
Grove  
NATURE CENTER





# LOCUST GROVE NATURE CENTER

Montgomery County, Maryland

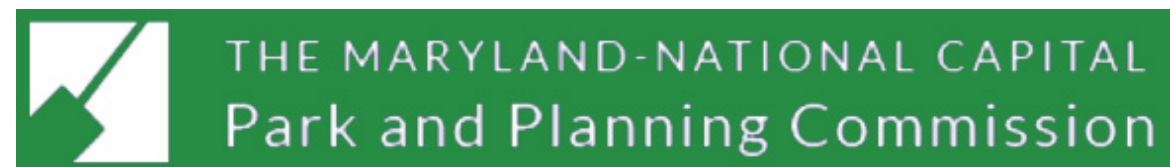


## LARC642 GRADUATE LANDSCAPE ARCHITECTURE STUDIO III

FALL 2017

Carey Evans, Katie Ferguson, Pam Parker, Afrouz Rahmati,  
Matt Rausch, Lotoia Simpson, Sebastian Velez-Lopez, Keren Zhang

Under the supervision of Professor Christopher D. Ellis, PhD, RLA, ASLA



**Landscape Architecture**  
DEPARTMENT OF PLANT SCIENCE AND LANDSCAPE ARCHITECTURE



# Acknowledgments

## Maryland National Capital Park and Planning Commission (MNCPPC)

## Montgomery County Planning Board

**Casey Anderson, Chairman**

**Norman Dreyfuss**

**Natali Fani-Gonzalez**

**Gerald R. Cichy**

**Tina Patterson**

## Montgomery Parks

**Mike Riley, Director of Parks**

**John Nissel, Deputy Director, Operations**

**Mitra Pedoeem, Deputy Director, Administration**

**John Hench, Division Chief, Park Planning & Stewardship**

**David Vismara, Division Chief, Horticulture, Forestry & Environmental Education**

**Laura Dechter, Chief Performance Officer**

**Rachel Newhouse, Park Planner Coordinator, Landscape Architect**

## Partnership for Action Learning in Sustainability (PALS)

**Gerrit Knaap, Director, National Center for Smart Growth**

**Uri Avin, PALS Director and Research Professor**

**Kimberly Fisher, PALS Program Manager**



# Table of Contents

**Executive Summary 1**  
**Introduction 3**

## **NATURE CENTER PRECEDENT STUDIES**

**Introduction 6**  
**Eastman Nature Center 7**  
**Irvine Nature Center 8**  
**Los Alamos Nature Center 9**  
**Portage Lakefront and Riverwalk 10**  
**Environmental Nature Center 11**  
**St. Landry Parish Visitor Center 12**  
**Robinson Nature Center 13**  
**Knoch Knolls Nature Center 14-15**

## **SITE ANALYSIS**

**Introduction 18**  
**History of Cabin John Area 19**  
**Geomorphology of the Maryland Lower Piedmont 20**  
**Site Geomorphology 21-23**  
**Terrestrial Habitat 24-25**  
**Aquatic Habitat 26-27**  
**Neighboring Land Uses 28**  
**Interior Land Uses 29**  
**Existing Circulation 30-31**



## **SITE FACILITIES STANDARDS**

**Introduction 34**  
**Accessibility 35**  
**Parking and Access Drive 36**  
**Nature Play Spaces 37-38**  
**Wayfinding Signage 39**  
**Trails and Maintenance 40**  
**Stormwater Best Management Practices:**  
    **Permeable Paving 41**  
    **Bioretention 42**  
    **Green Roofs 43**  
    **Cisterns 44**  
**Pollinator Habitat Considerations 45**

## **MASTER PLAN + SITE DESIGNS**

**Master Plan 48-50**  
**Site Designs:**  
    **Discovering Connections through Nature 51-53**  
    **Nature's Embrace 54-58**  
    **Bringing Nature Within Reach 59-62**

**References 63-64**





# Executive Summary

Today Locust Grove Nature Center is housed in a small, aging retrofit facility adapted from a toboggan run that opened its doors in 1972, operating for a few short years before shuttering in 1977. The current demand for year-round programming and multi-functional event space far exceeds Locust Grove's capacity.

The location of the nature center uniquely positions Locust Grove to serve as an in-demand local resource that draws a diverse array of visitors from across Montgomery County. One of its primary advantages is its proximity to Cabin John Creek, and thus also its position within the greater Cabin John Regional Park. The ecological amenities of Cabin John include unique natural landforms and wildlife habitats associated with Maryland's Piedmont region. Locust Grove's trail

system and grounds present the rich story of natural heritage located well within the urbanized boundaries of the county. Another significant benefit of Locust Grove's location is its position along Democracy Boulevard near the I-270 interchange with the Capital Beltway. This immediate proximity to the Beltway, the backbone of D.C. metro area's circulation, provides convenient access from most areas of Montgomery County and the greater D.C. metro region. Locust Grove has excellent visibility from this major arterial road which is unique among comparable nature centers in this region. In addition, its topography is naturally suited for supporting a large structure. Locust Grove has ample acreage of high quality, gently sloped land available to suit a major new facility that could

meet the growing demand for this type of facility.

This report reviews a series of high profile nature centers recently built across the United States including two prominent facilities located in Maryland: Robinson Nature Center in Howard County and Irvine Nature Center in Baltimore County. It also examines the natural features of Cabin John Park to identify opportunities and constraints related to nature center design. Additionally, one chapter is devoted to reviewing important design standards including site accessibility, vehicular circulation, stormwater management, and habitat restoration. Finally, three alternative conceptual designs are presented as an exercise in generating ideas

for the design of a new nature center for Locust Grove.





# Introduction

At the southern end of Cabin John Regional Park, situated just off busy Democracy Boulevard, Locust Grove Nature Center provides a convenient, tranquil nature getaway. The center's trails and creek access are treasured by the local community. The nature center has exhibits open for self-exploration, both indoors and outdoors.

## Problem Statement

Locust Grove Nature Center is well-positioned to become a celebrated community destination, but its current limitations must be resolved before that vision can be realized. The most significant challenge is the limited building size and lack of necessary amenities inherent to a thriving nature center. This limitation goes hand-in-hand with a severe lack of accessible elements. All potential visitors must feel equally welcome through equitable access.

## Charge to the Design Team

The challenge posed to the design team was to re-imagine Locust Grove Nature Center as a nature-centric destination that brings together people of all ages, abilities, and interests.

## Goals

Seven primary goals guided the design process from start to finish were:

- Create opportunities to embrace nature through sensory experiences
- Design with sensitivity toward conservation and sustainability
- Maximize educational opportunities
- Consider ways to engage the public, volunteers, and sponsors
- Support programming for all ages and abilities
- Design spaces that are flexible and multifunctional
- Design for nature-centered recreation



## Process

The design process began with establishing a thorough review of eight state-of-the-art nature centers across the country. Each center's design features and amenities were assessed.

From this point, a detailed site analysis of Locust Grove was conducted. The site analysis elements that were researched include history of the Cabin John area, regional geomorphology, geomorphology analysis of slopes, drainage, and soils, terrestrial habitat, aquatic habitat, neighboring land uses, interior land uses, and existing circulation.

Next, a series of site facilities standards was thoroughly

explored and documented, including accessibility, parking and access drives, nature play spaces, trail design and maintenance, wayfinding signage, stormwater best management practices, permeable paving, bio-retention, green roofs, cisterns, and pollinator habitat design.

Finally, a Master Plan was developed to maximize Locust Grove's connections to surrounding neighborhoods and to the greater Cabin John Regional Park. A higher level of design detail was necessary for the heart of the Locust Grove site, anchored by a re-imagined nature center that featured the amenities and spaces necessary to ensure it can become a valued community resource. Three distinct designs were developed to enhance the ecologically-rich site and maximize its visibility and impact.

The resulting designs offer myriad of ways to maximize Locust Grove's potential to become an important cultural, ecological, and economic asset for Montgomery County.







# Nature Center Precedent Studies



# Introduction: Precedent Case Studies

Precedent case studies provide insight about design elements that are suitable for a given design problem. In this case, they help identify features appropriate for designing a nature center. The centers reviewed here include examples from different regions of the United States including Maryland, Minnesota, California, New Mexico, Louisiana and Illinois. Analyzing these centers helped clarify critical elements for indoor and outdoor public spaces including educational spaces, gathering spaces, areas for habitat restoration, and outdoor exhibit areas. Many of the case studies also included sustainability features such as rain gardens, bio-infiltration swales, and energy-autonomous building design.



## Table of Contents

- Eastman Nature Center- Elm Creek Park, Minnesota. . . . . 7
- Irvine Nature Center- Owings Mills, Maryland . . . . . 8
- Los Alamos Nature Center- Los Alamos, New Mexico . . . . . 9
- Portage Lakefront and Riverwalk- Portage, Indiana . . . . . 10
- Environmental Nature Center- Newport Beach, California . . . . . 11
- St. Landry Parish Visitor Center- Opelousas, Louisiana . . . . . 12
- Robinson Nature Center- Columbia, Maryland . . . . . 13
- Knoch Knolls Nature Center- Naperville, Illinois . . . . . 14-15

# Eastman Nature Center- Elm Creek Park, Minnesota



Figure 1. Eastman Nature Center: Entrance View (threeiversparks.org)

## Three Rivers Park District's Goal for Nature Center

Eastman Nature Center is a section of the Elm Creek Park located in the Three Rivers Park District in north-west Minneapolis. The Three River's Park District goal for the Eastman Nature Center was to create a stimulating learning environment that heightens the awareness of nature in a highly sustainable building.

The design integrates site, building, and exhibit design to create a holistic visitor experience in the forest. A long south-facing glass facade brings in light, passive solar energy, and extends the exterior paths through the building from the under-story from one end of the tree canopy to the other. An active solar array and a geothermal-based heating and cooling system supply much of the building's energy. Operable windows provide ventilation and bring in the sounds and smells of the forest. Roof water feeds a pond that draw birds and animals for human observation. (14,000 sq. ft.)

Eastman Nature Center  
13351 Elm Creek Road  
Dayton, Minnesota 55369  
ph: 763-694-7700  
9:00am-5:pm Mon-Sat,  
Noon-5:00pm Sundays

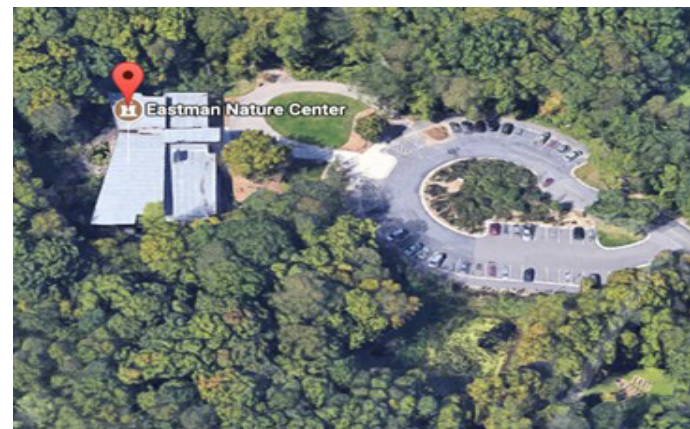


Figure 2. Eastman Nature Center: Overhead View (threeiversparks.org)

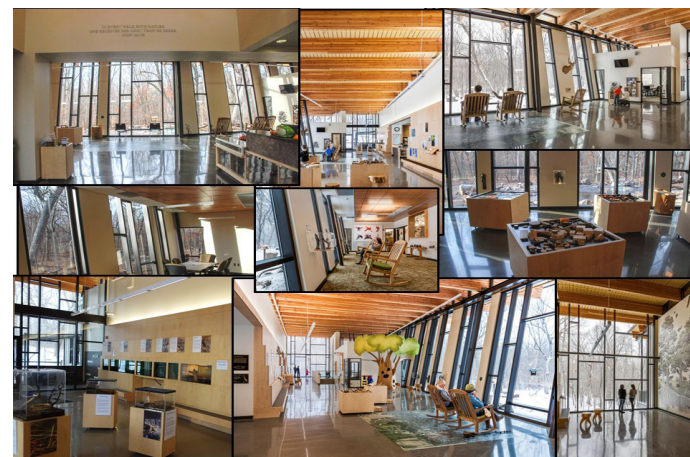


Figure 3. Eastman Nature Center: Interior Views (threeiversparks.org)

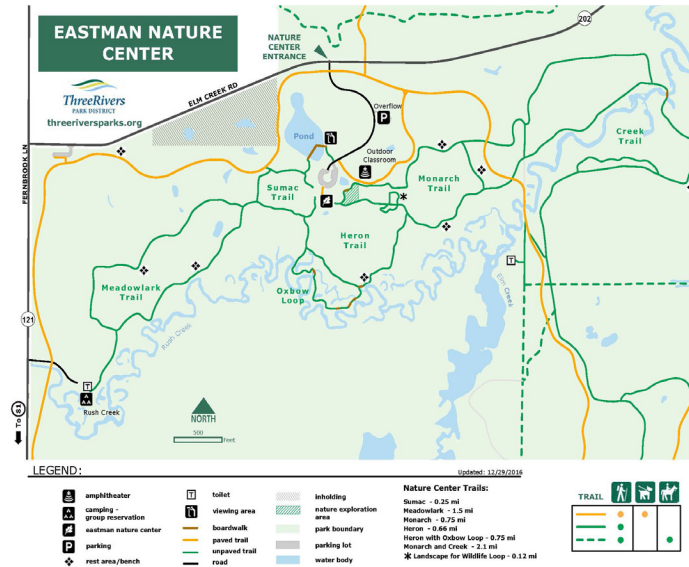


Figure 4. Eastman Nature Center: Map and Legend (threeiversparks.org)

The Eastman Nature Center is named for Whitney H. Eastman, an avid birdwatcher and advocate of environmental education. The Center provides floor-to-ceiling windows to entice visitors to also do some indoor birdwatching. Additionally the Center provides:

- Live reptiles and amphibians in rotating interpretive displays throughout the building.
- Children enjoy hands-on activities, dressing up in costumes, and putting on a puppet show in the puppet tree.
- Quiet reading room, a screened-in and open-air deck, large classrooms, and an after-hours restroom.
- Opportunities to enhance the trail experience along the trails are available through:
  - Cell phone audio stops,
  - Trail guide sheets,
  - Exploration kits,
  - Interpretive signs.
- Down the trail, children can play "wild" in the nature exploration area. Kids can dig, climb, make a fort or dam, and engage their imaginations, while adults play along or observe nearby.

Eastman Nature Center, like the Locust Grove Nature Center, is in a larger Park. Locust Grove is a part of the Cabin John Creek Park, Eastman Nature Center is a part of the Elm Creek Park Reserve.

The 5,315-acre Elm Creek Park Reserve allows Eastman to leverage its 19 miles of paved biking/hiking trails, 21 miles of horse trails, and a 13 miles of mountain bike trails as part of its programmed experiences. In the winter, portions of the 11-mile cross-country ski trail system are maintained by snow-making. The terrain of the larger Elm Creek Park Reserve also offers a snow-tubing hill and a small downhill ski/snowboard area.

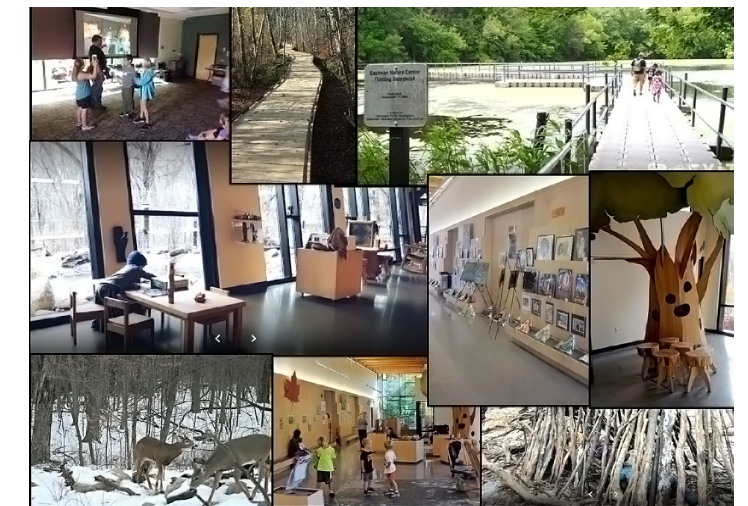


Figure 5. Programming Examples (threeiversparks.org)



Figure 6. Programming Examples and Activities (threeiversparks.org)

Additional programming includes: Aquatic Life Study, Astronomy, Land Insects, Maple Syrup, Apple Cider, Orienteering, Weather, Plant Structures, Snowshoeing, Historical Games, Habitats Study, Birds: Big & Small, Survival Challenge, Reptiles & Amphibians, Geology, Water Quality & Watersheds, Animal Tracking & Signs Winter Water Properties, Geology: Soils & Land.

# Irvine Nature Center- Owings Mills, Maryland

## About Irvine Nature Center

The Irvine Nature Center is located in southwest Baltimore County. It was founded in 1975 and today, is the only private, non-profit environmental education center in the area.

Irvine Nature Center offers various programs of environmental studies and environmental science for all ages.

The site has a diversity of Piedmont habitats, including open wetlands, forest wetlands, upland forest, and meadow, covering 210 acres.



Figure 1. The Environmental Education Building of Irvine Nature Center ([www.explorenature.org](http://www.explorenature.org))

## Site Map

The site map shows the layout of Irvine Nature Center. Facilities include an environmental education building, a 4,200-square foot parking lot, an outdoor classroom, a woodland garden near the building, and abundant natural landscapes, including upland forest, bottom land forest, south meadow, central meadow, wetland meadow, back meadow, vernal wetland, and a reforestation area. Some activity areas are located in the natural landscapes, including the education hut in the upland forest, the wigwam in the bottom land forest, and the camp shelter in the central meadow.

Some trails (gray- blue lines on the site map) are less accessible during rainy season due to the soft ground.



Figure 2. Site Map ([www.explorenature.org](http://www.explorenature.org))

## Signage



Figure 3. Signage ([www.google.com](http://www.google.com))  
 (1) in front of the building; (2) in the nature play ground; (3) in the meadow

## Programs

### Nature Preschool

Irvine Nature Center offers a nature preschool for 3 to 5 years old. Kids can develop knowledge and skills through outdoor exploration and creative arts. It can also help kids to gain an appreciation and respect for the natural world.



Figure 4. Preschool Program ([www.explorenature.org](http://www.explorenature.org))

### School Programs

Irvine offers school programs for students and teachers. Students can come on field trips, or the nature center can visit their school.

Irvine also offers professional development opportunities for teachers to integrate environmental education into their courses.



Figure 5. School Program ([www.explorenature.org](http://www.explorenature.org))

### Public Programs

Public programs are offered for all ages with different activities to allow all ages to join in experiencing nature. People can hold parties and weddings at the center.

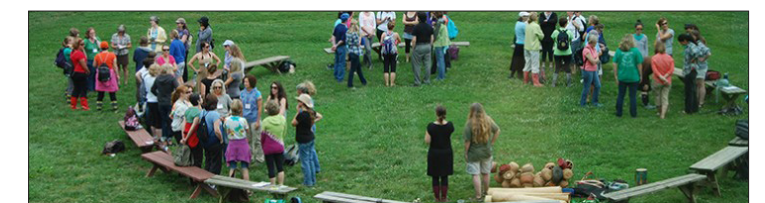


Figure 6. Public Program ([www.explorenature.org](http://www.explorenature.org))



# Los Alamos Nature Center- Los Alamos, New Mexico

The Los Alamos Nature Center in Los Alamos, New Mexico opened in April 2015 with the express goal of connecting people with nature. The Pajarito Environmental Education Center (PEEC), a non-profit organization, operates the Los Alamos Nature Center.



Figure 1. The nature center is constructed from locally sourced materials. ([www.pecnature.org](http://www.pecnature.org))

PEEC inspires visitors to better understand and care for the local environment, while becoming good stewards of New Mexico's unique natural heritage. It serves 40,000 adults and children each year through the nature center; public programs such as talks, hikes, outings, and classes; school lessons and field trips; and a state-of-the-art planetarium.

The Los Alamos Nature Center won the 2016 Governor's Environmental Excellence Award for environmental education and outreach. This state-of-the-art nature center is treasured by the local community and celebrated by visitors from around the world.

## Nature Center Building

The nature center is perched at the edge of a canyon, with sweeping views of the Pajarito Plateau. Its glass facade showcases the landscape so that visitors engage with nature from a variety of vantage points via the

building's indoor-outdoor experience.

## Technology

Los Alamos Nature Center has firmly embraced technology to enhance the visitors' experience and understanding of the natural landscape.

From taking a virtual tour of the center to linking visitors to an interactive trail app, the website sets the tone for the nature center's exciting digital platforms.

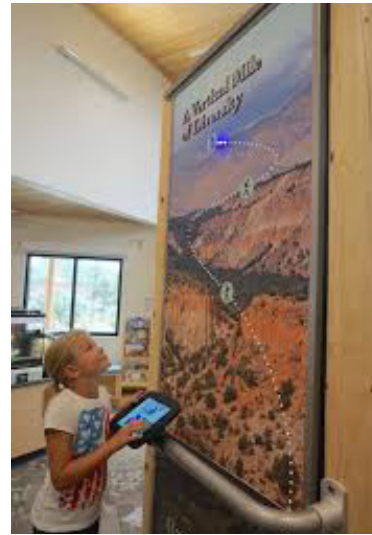


Figure 2. Interactive digital exhibits ([www.pecnature.org](http://www.pecnature.org))



Figure 4. The Planetarium ([www.pecnature.org](http://www.pecnature.org))

The center also features a state-of-the-art planetarium that is an astronomy, space science, and nature education resource for northern New Mexico. Its domed theater is 30 feet in diameter, and it comfortably immerses 50 people at a time.



Figure 3. The nature center blends the indoor spaces with the surrounding landscape. ([www.pecnature.org](http://www.pecnature.org))

## Nature Play Space



Figure 5. The Nature Play Space expands children's relationships with nature ([www.pecnature.org](http://www.pecnature.org))

## Public Engagement

The center offers a wide variety of programming for all ages, abilities, and interests. It hosts many free public events throughout the year, including an annual Earth Day celebration. The center is a hub for interest groups and clubs ranging from hiking and yoga to bird watching. The nature center also has many rentable spaces available to the community.



Figure 6. Annual Earth Day celebration ([www.pecnature.org](http://www.pecnature.org))

# Portage Lakefront and Riverwalk- Portage, Indiana

## Waterfront Restoration

Portage Lakefront and Riverwalk, Portage, Indiana, opened in 2008. This waterfront restoration project is the first completed demonstration project of the SmithgroupJJR "Marquette Plan," an ambitious multiyear strategic plan to reinvigorate an ecologically damaged 50-mile stretch of Indiana's Lake Michigan shoreline. The city of Portage partnered with the National Park Service to remake 60 acres of former steel mill wastewater treatment brownfields into a public beach, dune restoration site, and a stunning curvilinear and glass visitors' center.

A performance study of the completed project was undertaken through the Landscape Architecture Foundation (Ellis *et al.* 2011). The report itemized the project's positive environmental impacts. Fifty-five acres were restored using native species, although post construction documentation of plant and animal species was unavailable for this evaluation. Documentation of water infiltrates (not a problem on sand), benefits of native plants (100%), recycled materials from demolition (75%), and social benefits (nature education, recreation, and employment) quantify the project's ecological and cultural. Furthermore, the site's remarkable beauty and power of the place is inarguable evidence.

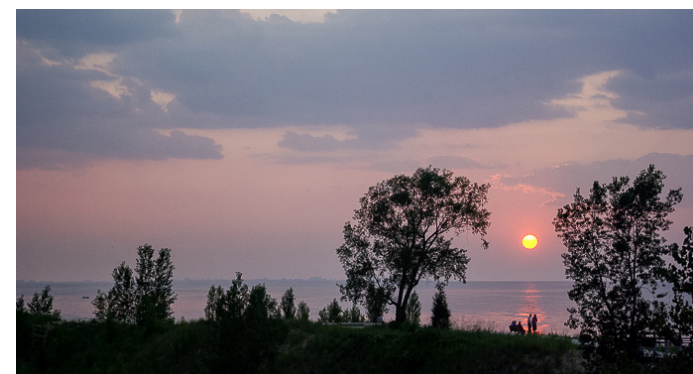


Figure 1. Portage Lakefront  
([www.nps.gov](http://www.nps.gov))



Figure 2. The Pavilion at Portage Lakefront and Riverwalk  
([www.nps.gov](http://www.nps.gov))



Figure 3. Lake Michigan and fishing pier  
([www.nps.gov](http://www.nps.gov))



Figure 4. Visitors at the Lakefront Pavilion  
([www.smithgroupjjr.com](http://www.smithgroupjjr.com))



Figure 5. Native plants are used in dune restoration  
([www.landscapeperformance.org](http://www.landscapeperformance.org)) by Sarah Alward



Figure 6. Dune grasses limit erosion at the Lakefront  
([www.landscapeperformance.org](http://www.landscapeperformance.org))



Figure 7. Lake Michigan beach at Portage Lakefront  
([www.smithgroupjjr.com](http://www.smithgroupjjr.com))

PRECEDENT CASE STUDIES: Portage Lakefront and Riverwalk

# Environmental Nature Center- Newport Beach, California

The Environmental Nature Center (ENC) is located in Newport Beach, California. The ENC was founded in 1972 by local teachers and community members to provide a space for environmental education of local students. The chosen site was a gully filled in by soil dumped from a new Olympic swimming pool that was being excavated nearby. Students and local volunteers helped shape and plant the site with a variety of California native plant communities and formed an area of impressive biodiversity. The new building, completed in 2008, is the first in Orange County to earn a LEED Platinum rating. With this building, educational opportunities are available both inside and outdoors.

## Nature Learning

California is a large state and home to a wide variety of plant communities ranging from desert to evergreen forest. Fifteen of these communities are replicated at the ENC to provide hands-on learning opportunities. Extensive information is provided on the range of species at the site and that can be viewed on walks. The original landscape plan was designed by Fred Lang and Ann Christoph with attention to native vegetation that would thrive with minimal maintenance.

The ENC also has a Butterfly House, which is home to several species of caterpillars and butterflies that are native to Orange County. The Butterfly House is full of native plants that support the butterflies and serves to promote the use of native plants by visitors at their own homes.

Camps and field trips give local children abundant opportunities to spend time at the ENC and learn more about nature. Camps are available over most school holidays and vary in programming, but children spend most of their time outdoors and learning about nature.

The ENC is currently raising money to build a nature preschool and plans to break ground in late 2017. The preschool building will participate in the Living Building Challenge and provide nature experiences for up to 72 children every day.



**Figure 1. Butterfly House at the ENC**

Families view the native plants that attract butterflies and hope to interact with some of the residents of the Butterfly House. (encenter.org)

## Adult Learning and Activities

Birding is encouraged and very popular at ENC. The abundant native vegetation attracts many native birds and insects. Visitors can see a list of species that have been spotted at the ENC and visitors are encouraged to expand this list by emailing any new species they see during their visit.

Programming for adults includes tours, photography walks, lectures, and gardening tips to attract native butterflies and other animals.

The ENC is also a rentable facility for meetings, parties, weddings, and other events. Rental proceeds go toward improving environmental education at the ENC.

Abundant information on plant species, vegetation communities, butterflies, birds, and programming is available on the ENC website. It also shares information about the LEED Platinum building and its water and energy saving features, also making it a source of education.



**Figure 2. Environmental Nature Center building**

The LEED Platinum building is 8,500 sq. ft. and houses classroom and educational space. (encenter.org)

## LEED Platinum

The ENC was the first building in Orange County to achieve a LEED Platinum rating. This 8,500-sq. ft. structure uses its coastal, southern California location to capture sea breezes for natural ventilation and uses the sun for its energy, both actively through solar panels and passively through building design. Maintenance is reduced by careful selection of materials that require little attention or upkeep. Many materials are also light-colored, reducing their heat absorption and decreasing the heat island effect. Overall, the building and site are water efficient, using native vegetation outdoors and low-flow features indoors to reduce the use of potable water. The ENC building was designed by LPA, Inc. and earned 55 out of a possible 69 LEED points based on six rating categories: sustainable sites, water efficiency, energy and atmosphere, materials and resources, indoor environmental quality, and innovation in design.

# St. Landry Parish Visitor Center- Opelousas, Louisiana

“St. Landry Parish serves as the northern gateway to Louisiana’s Acadiana region, Louisiana. This center is providing the visitors a close experience with forests, swamps, etc. Through this visitor center, travelers are able to gain an understanding of the region’s distinctive character.” (ASLA.org /2016awards).

## Project Narrative

St. Landry Parish Visitor Center offers a great solution for sustainability along Interstate 49, in the northern Acadiana region. It features interpretive native landscapes, rain gardens, exhibit spaces, restrooms, and outdoor gathering and event areas with exhibits that reveal the landscapes, ecology, and history of this unique region. Building features references to Louisiana architectural styles, including deep-shaded porches, raised elevations for protection from rising waters, sloped roofs, and cistern-collected rainwater. These are used in tandem with more current responses like a vertical axis wind turbine and roof-integrated solar panels.

Rural Acadiana incorporates sustainable strategies in its design. The visitors’ experience begins within a parking zone composed of loose and permeable milled asphalt, harvested from a nearby highway resurfacing project. Paved paths use native aggregates, and open spaces are planted with native plants. At the visitor center there is slight transition between architecture and landscape. Due to the annual rainfall of 60-70 inches, the St. Landry Parish visitor center is attempting to manage its stormwater run off.

Travelers experience the area’s variety of ecosystems. The landscape design plays an important role in the project, using native plants that reflect several of Louisiana’s ecosystems.

The center has numerous advantages that create a resilient, sustainable, and educational dialogue, allowing it to serve as a precedent in the region and elsewhere.



Figure 1 : Sustainable solution (www.asla.org)



Figure 2 : St. Landry Front view (www.asla.org)



Figure 3 : Main Entrance and Rain gardens (www.asla.org)

With its environmentally sensitive design and use of regional materials, the center has a light footprint on the landscape. Visitors receive an education in these design practices and insight into the local ecology, culture, and traditions. The project has transformed the concept of the visitor experience for the state agencies that develop and manage similar facilities, and has become an educational model for students from multiple disciplines.



Figure 4 : Main Entrance and Rain gardens (www.asla.org)

# Robinson Nature Center- Columbia, Maryland

“Our mission is to facilitate the enjoyment and understanding of our natural resources and to bridge the gap between people and nature. By inspiring sound environmental awareness, we promote responsible stewardship of all of our natural resources and strive to connect people of all ages with nature through experience-based education.”

-Robinson Nature Center

Robinson Nature Center is located on 18 acres of land next to the Middle Patuxent Environmental Area in Columbia, Maryland. It was built by the James and Anne Robinson Foundation, and it is now owned and run by Howard County Government.

## Building and Grounds

Geothermal heating and air-conditioning, porous paving, solar panels, minimal lawn, extensive native meadow planting, LED lighting, energy efficient equipment in the water feature, environmental site design for stormwater management, and the use of native and drought tolerant plants to Platinum LEED Certification for Sustainability.



Figure 2. View of the Nature Center from the Drop-off Loop ([www.meetup.com](http://www.meetup.com))

The water feature, winding meadow pathways, forest trails, and nature play space create an immersive natural experience for people of all ages. The building includes several amenities, such as ample classroom space, a planetarium, a multipurpose room, and a variety of exhibition spaces. A large balcony, a patio with tables, and a space around the water feature serve as gathering spaces.

## Programming

Robinson Nature Center offers a variety of programming for all ages including toddlers, pre-schoolers, elementary school children, Cub Scouts, Boy Scouts, and adults. Events such as their Howling Halloween Hullabaloo or Deer Santa, bring families with young kids to celebrate seasonal holidays. The planetarium holds family-friendly movie nights that teach people about subjects such as astronomy and nocturnal animals. The center also holds classes throughout the fall, winter, and spring. For school-aged children, there are activities such as night hikes and trips to explore the river. Adults can enjoy social activities like coffee and wine tastings, hikes, and classes where they can get certified as Master Naturalists. The Center also offers rental options for events such as birthdays, weddings, conferences, and movie showings.



Figure 5. Kids exploring the river ([www.baltimoresun.com](http://www.baltimoresun.com))

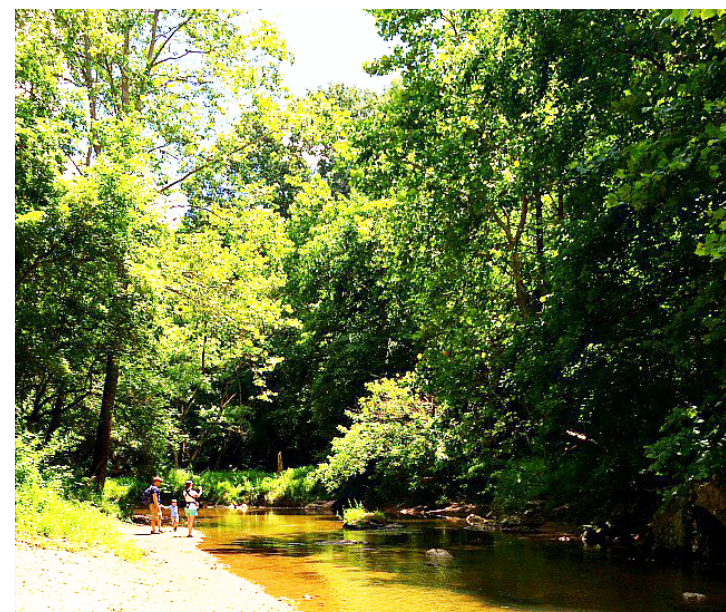


Figure 1. Trails lead to the Middle Patuxent River ([www.sunshinewhispers.com](http://www.sunshinewhispers.com))

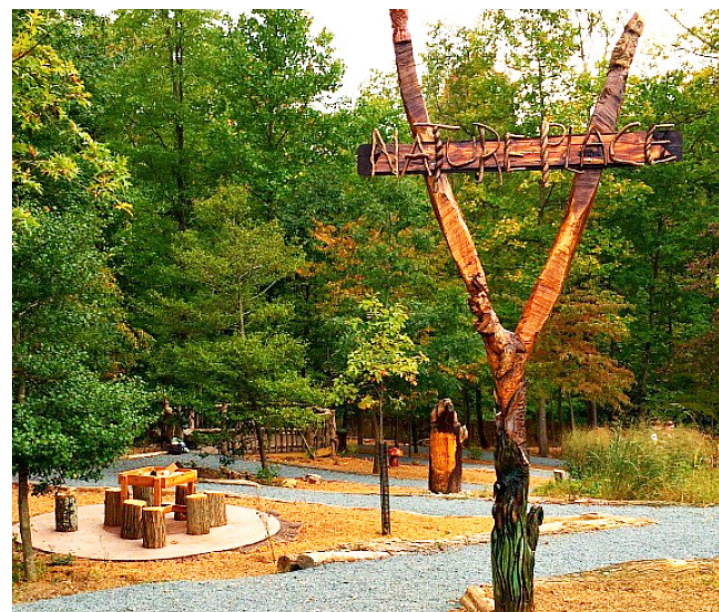


Figure 3. The Entrance to the Nature Play Space ([www.sunshinewhispers.com](http://www.sunshinewhispers.com))



Figure 4. The Nature Center seen over the native planted meadow ([www.tripadvisor.com](http://www.tripadvisor.com))

# Knoch Knolls Nature Center- Naperville, Illinois

## Building Views



Figure 1. Knoch Knolls LEED Award ([www.aiachicago.org](http://www.aiachicago.org))

The design for this LEED-Platinum certified facility features indoor and outdoor educational exhibits, two classrooms that are 100 percent day-lit, public restrooms, photovoltaic panels, a deck overlooking a reshaped pond, and a green roof. (Design Excellence Award, 2015)



Figure 2. Knoch Knolls nature Center opens in Naperville, focuses on water ([DailyHerald.com](http://DailyHerald.com))

The Naperville's Knoch Knolls gets eco-friendly upgrade. The nature center is the main element of a \$5.5 million plan for improvements at Knoch Knolls park in South Naperville.



Figure 3. North Elevation ([napervilleparks.occell.com](http://napervilleparks.occell.com))

"This fun nature scavenger hunt has been designed for families, scouts, preschoolers and homeschoolers to enjoy on the trails around the nature center approximately 1/2 of a mile long."

## Indoor Places



Figure 4. Main Entry Reception Desk ([www.aiachicago.org](http://www.aiachicago.org))

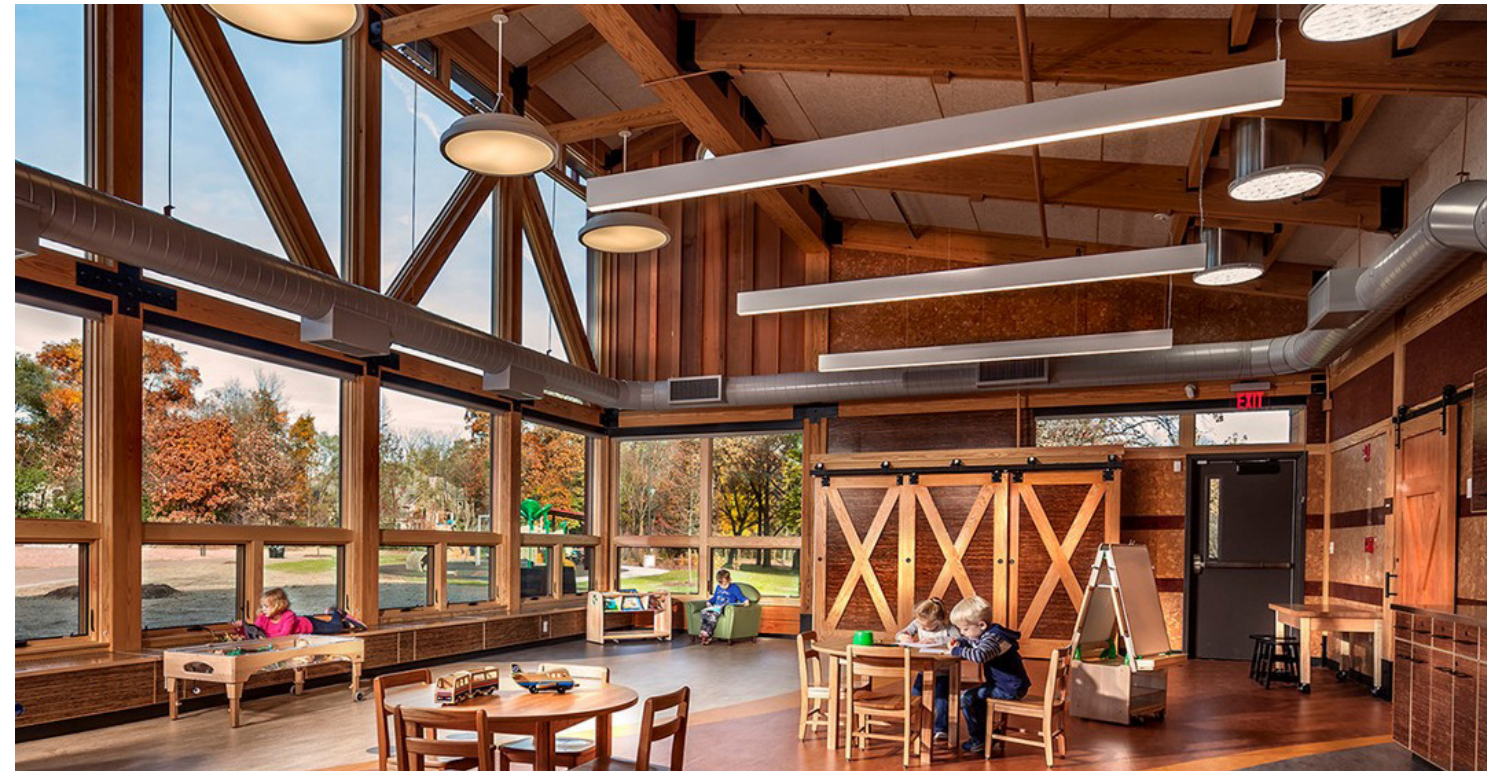


Figure 5. Indoor Classroom ([www.aiachicago.org](http://www.aiachicago.org))

The site includes two classrooms with views for staff and children

# Knoch Knolls Nature Center- Naperville, Illinois



**Figure 6. Indoor Exhibit (Napervilleparks.org)**  
The indoor exhibits engage visitors with sensory touch boards that educate guests about nature's habitats.



**Figure 7. Exhibit Technology Boards (Bluestoneinc.com)**  
Boards provide technology views with tablet screens.



**Figure 9. Boating and Kayaking (Napervilleparks.org)**  
Families can take a day to enjoy boating and kayaking along the Dupage River.



**Figure 8. Rain Water Harvest Cistern (www.aiachicago.org)**  
Educational and environmental feature within the site that holds 1,500 gallons of rain water.



**Figure 10. Outdoor Habitat (Napervilleparks.org)**  
Naperville Park District's state award-winning Toadstools & Pollywogs Preschool offers preschoolers the opportunity at Seager park to enjoy nearby walking trails, open fields, a pond, river and an abundance of wildlife that provides preschoolers with endless investigation opportunities







# Site Analysis



# Site Analysis

Locust Grove Nature Center is situated within the limits of Cabin John Regional Park. It is within the Cabin John Creek Watershed, which is part of the Potomac River Watershed. The site is bordered by Democracy Boulevard on the south and a Pepco electrical power line easement on the north. The east and west sides are bordered by residential areas, and it is near the Westfield Montgomery Shopping Mall. The site's interior is largely a steep forested gorge at the bottom of which sits the creek. These and other characteristics are all significant in designing new elements such as buildings, gathering spaces, and trails.

The first step in the design process is a thorough analyses of the site's environmental and cultural characteristics. Aspects were analyzed individually and then combined to guarantee an in-depth understanding of the site's advantages and limitations. The environmental analyses include regional and local geomorphology, as well as terrestrial and aquatic habitats. Cultural aspects include history, neighboring and interior land uses, and existing circulation. A greater familiarity with the site fostered design ideas that would serve the site's environmental and cultural characteristics.



MyGreenMontgomery.org



www.patch.com



www.MontgomeryParks.org



www.MontgomeryParks.org



Google Street View

## Table of Contents

- History of the Cabin John Area ..... 19
- Geomorphology of the Maryland Lower Piedmont ..... 20
- Site Geomorphology ..... 21-23
  - Slope
  - Drainage
  - Soil
- Terrestrial Habitat ..... 24-25
- Aquatic Habitat ..... 26-27
- Neighboring Land Uses ..... 28
- Interior Land Uses ..... 29
- Existing Circulation ..... 30-31

# History of Cabin John Area and Locust Grove

## History of Cabin John Area

### Pre-Nineteenth Century

Native Americans were the first people to live in the Cabin John area.

In the early 17<sup>th</sup> century, the first European explorers found this place.

Maryland became a settled colony in the middle of the 17<sup>th</sup> century. Lord Baltimore made several land grants along the Potomac River, Cabin John was among them.

### Nineteenth Century

In the 19<sup>th</sup> century, due to the construction of the C & O canal, a large number of settlers came to the Cabin John area, but land ownership was concentrated. At the end of this century, three families owned all the property of this area.

During this period, most parts of Cabin John were farmland.

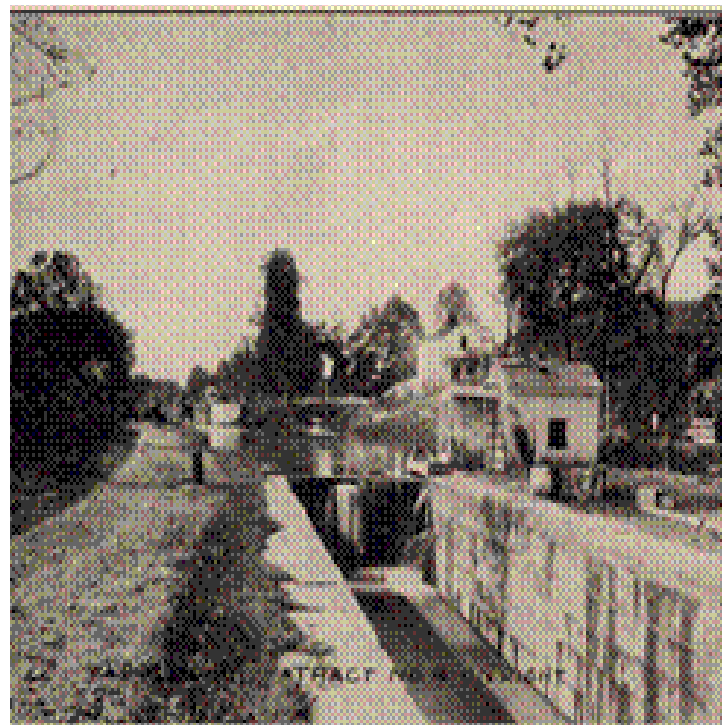


Figure 1. Locks 9 & 10 on the C&O Canal. (glenecho-cabinjohn.com)



Figure 2. A large flock of sheep in Cabin John area. In nineteenth century, most of Cabin John was farm land. (glenecho-cabinjohn.com)

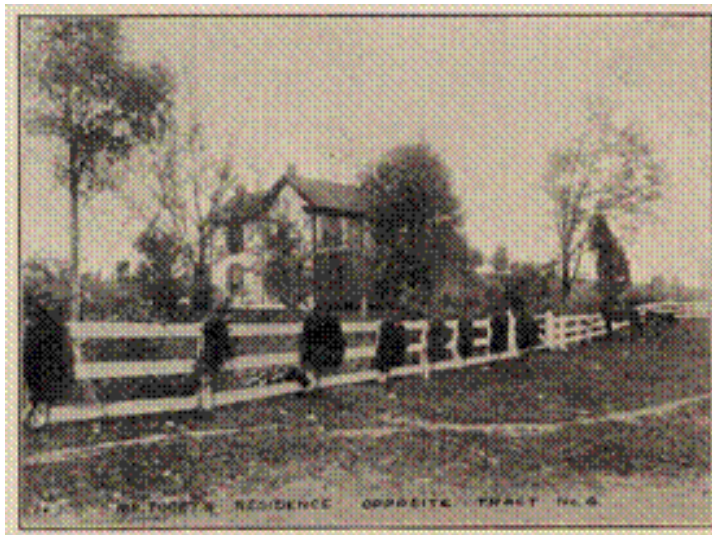


Figure 3. The Old Cabin John Family Home (glenecho-cabinjohn.com)

### Twentieth Century

In 1912, the American Land Company purchased a large amount of land in the area, divided it into residential lots for sale. The area's population began to grow steadily and developed a community atmosphere.

In 1919, area residents set up the Cabin John Park Citizens Association, and began to focus on and improved infrastructure for the communities. For example, in 1930, the community established the Cabin John Volunteer Fire Department, which was composed of Cabin John residents.

In the late 1960s and early 1970s, real estate developers sought to buy unused land and establish high-density housing in the area.

Residents concerned about the changes in the regional ecology and lifestyle prompted negotiations with the local government and resulted in a community development plan that included a new commercial area.

### Present Day

Today, the Cabin John area is a wooded residential area of 860 families (about 2,300 people). There are dozens of businesses and a community center.



Figure 4. The Present Cabin John Family Home (redfin.com)

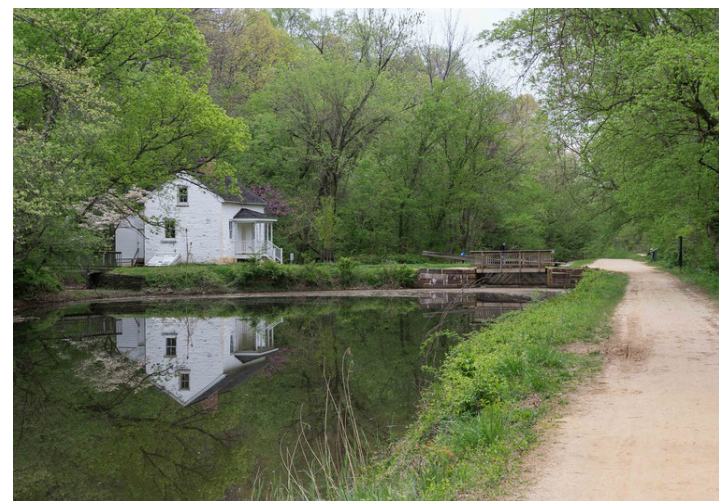


Figure 5. The Present C&O Canal (canaltrust.org)

## History of Locust Grove

Locust Grove Nature Center originally opened in 1972 as a toboggan run. The facility had two toboggan chutes and a warm-up room. The runway was closed in 1977 due to a lack of snowfall. Today, Locust Grove Nature Center is a nature conservation center.

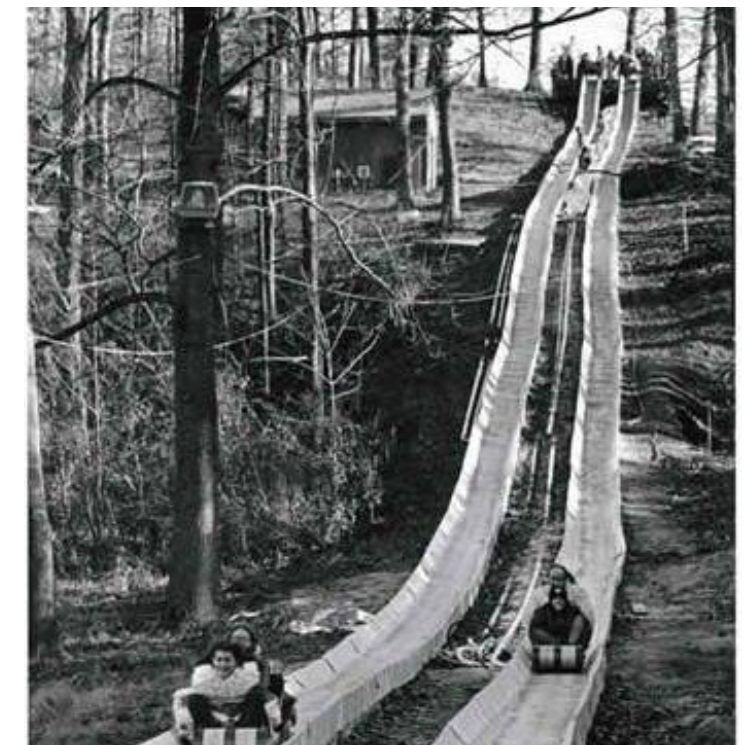


Figure 6. The Old Toboggan Run (montgomeryparks.org)

Locust Grove provides various programs for all ages. It serves as a peaceful natural setting for people to escape the noise and fast-pace of the surrounding area.



Figure 7. Locust Grove Nature Center Building (culturespotmc.com)

# Geomorphology of the Maryland Lower Piedmont

## Piedmont Physiographic Province

Cabin John Regional Park is located in the eastern half of the Piedmont physiographic province of Maryland. This lower area of the Piedmont is located near a border with the Atlantic Coastal Plain province, which stretches from the Montgomery-Prince George's County line to the Chesapeake Bay and the Atlantic Ocean.

Specifically, Cabin John Regional Park lies within the Hampstead Upland District of the Piedmont physiographic province. This region is characterized by a combination of upland areas and steep-walled gorges. The uplands can be hilly or gently rolling and are interrupted by streams that lie within areas that have weathered differently to produce steep valleys. This type of Piedmont district is common and representative of about half of Montgomery County.

## Montgomery County Geology

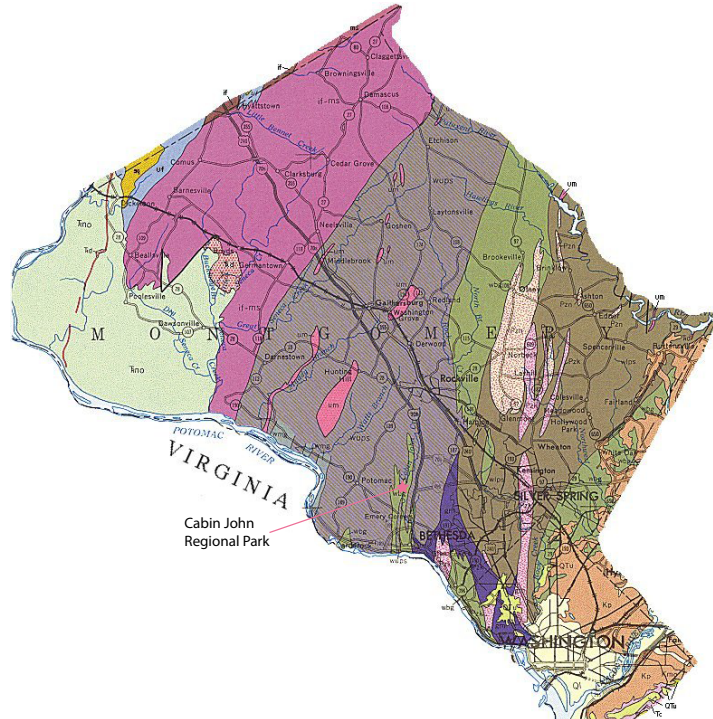
The area around Cabin John Regional Park is underlain by Precambrian bedrock that includes the Upper Pelitic Schist formation. This thick layer of metamorphic rock was originally formed more than 500 million years ago and experienced heat and pressure that transformed it to its current state. The rock is fairly coarse-grained and contains albite, chlorite, muscovite, and quartz.

There is an area of Paleozoic igneous bedrock located near Cabin John Regional Park that may affect the area's topography. This later intrusion was likely formed from underground magma that reached into the area and cooled slowly in place. These rocks include gabbro and serpentinite and may weather differently than surrounding Precambrian bedrock, resulting in the upland and valley topography described above.

Some gold deposits have been reported in Montgomery County. The geology of the Piedmont



**Figure 1. *Astrodon johnstoni***  
*Astrodon johnstoni*, originally found in Prince George's County, was named the Maryland state dinosaur in 1998 ([www.mgs.md.gov/geology](http://www.mgs.md.gov/geology)).



**Figure 2. Geologic Map of Montgomery County**  
 Geologic map of Montgomery County based on the Maryland Geologic Survey from 1968. The gray area in the center of the county represents the Upper Pelitic Schist formation; the green area by the Cabin John Regional Park area represents Boulder Gneiss, the Paleozoic intrusive formation ([www.mgs.md.gov/geology](http://www.mgs.md.gov/geology)).

metamorphic rocks can contain gold in grains, sheets, or wires within quartz veins. No gold has been reported within Cabin John Regional Park.



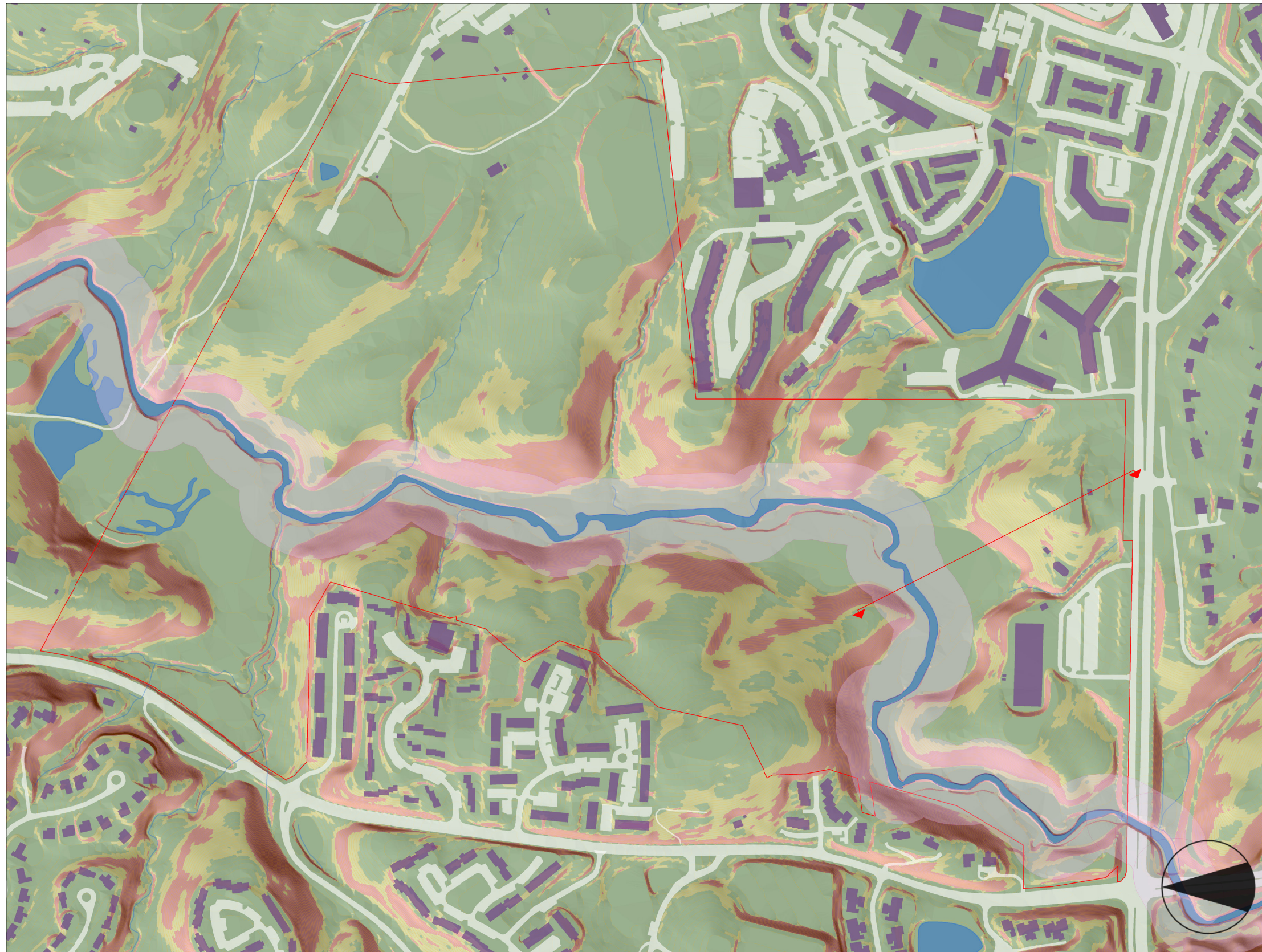
**Figure 3. Physiographic Map of Montgomery County**  
 Clip of Montgomery County from Physiographic Map of Maryland produced by the Maryland Department of Natural Resources and Maryland Geological Survey. The red star shows the approximate location of Cabin John Regional Park within the Hampstead Upland District of the Piedmont Plateau ([www.mgs.md.gov/geology](http://www.mgs.md.gov/geology)).

## Maryland Fossils

A variety of fossils have been discovered in Maryland, though none are reported in Montgomery County. Those in nearby counties include trilobites and dinosaurs in Frederick County, along with dinosaurs, mollusks, plants, and shark teeth in Prince George's County. The first dinosaur fossils ever discovered in

Maryland were teeth found in a mine in Prince George's County and belonged to the *Astrodon johnstoni*, now the state dinosaur of Maryland.

# Site Geomorphology

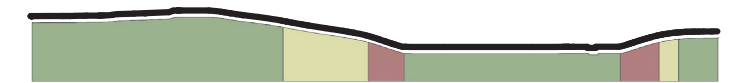


## Site Slope

This portion of the Cabin John Creek runs along the bottom of a deep gorge with many steep slopes. All along the sides of the floodplain are slopes with a 25% incline or greater. As per the Montgomery County Environmental Guidelines, a 150-foot buffer must be created along both sides of the stream bed. Areas within the buffer cannot be built on except for bike paths and trails where necessary to the park and nature center's function.

## Slope Profile

The section cut below shows the slope profile from the frontal area, across the small plateau behind the picnic shelter and down to the floodplain. There is an 80-foot difference in altitude between the plateau and the floodplain with a majority of slopes at a 15-25% grade.



## Map Legend (Figure 1)







-  Buildings
-  Impermeable Surfaces
- Gradients & Buffers**
-  0-15% Slope
-  >15 - 25% Slope
-  >25% Slope
-  Creek w/ 150' Buffer

Figure 1. Slope Gradients Map with Legend. ([www.montgomeryplanning.org](http://www.montgomeryplanning.org))

# Site Geomorphology

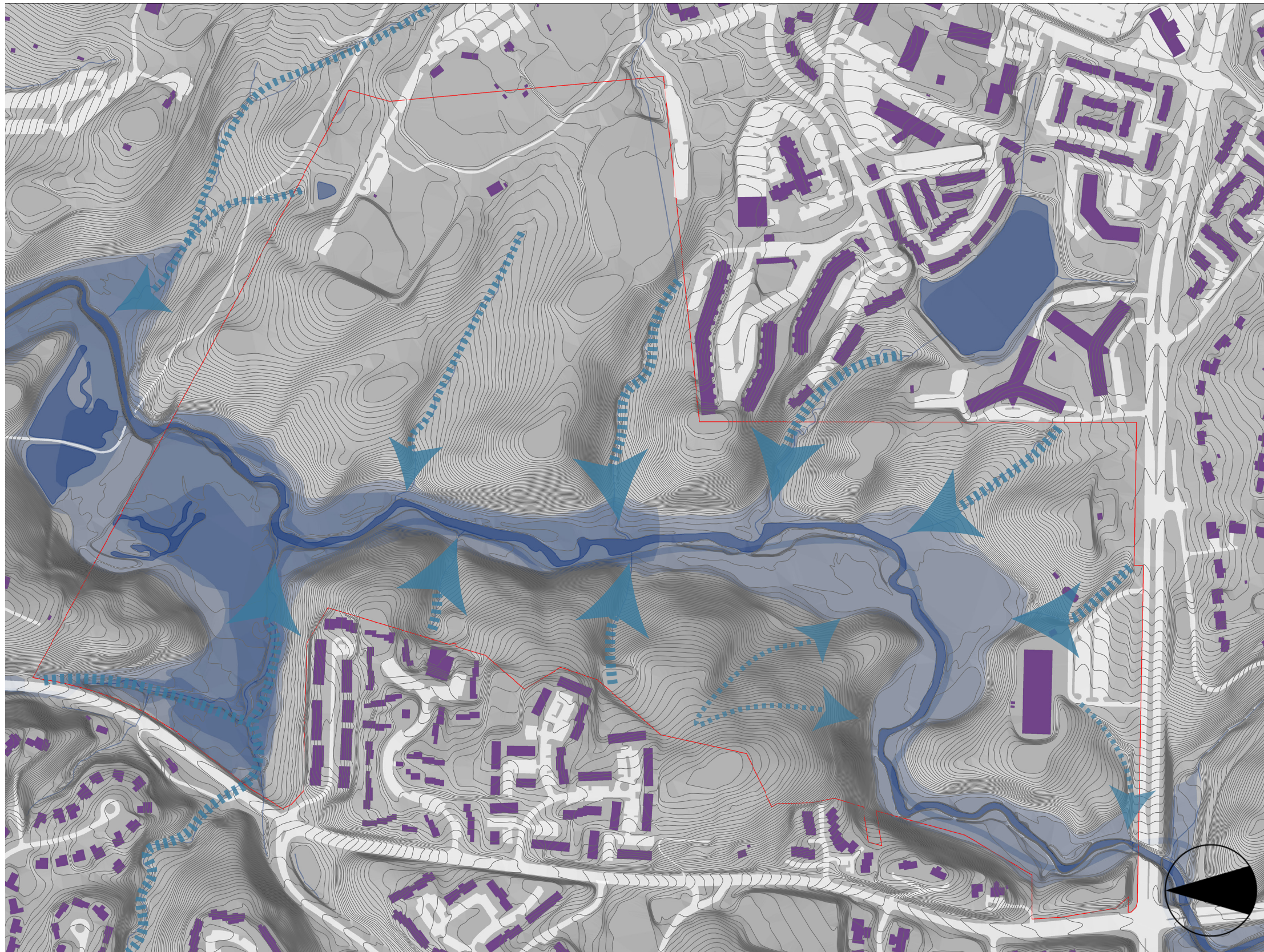


Figure 2. Site Drainage  
([www.montgomeryplanning.org](http://www.montgomeryplanning.org); [www.fws.gov](http://www.fws.gov))

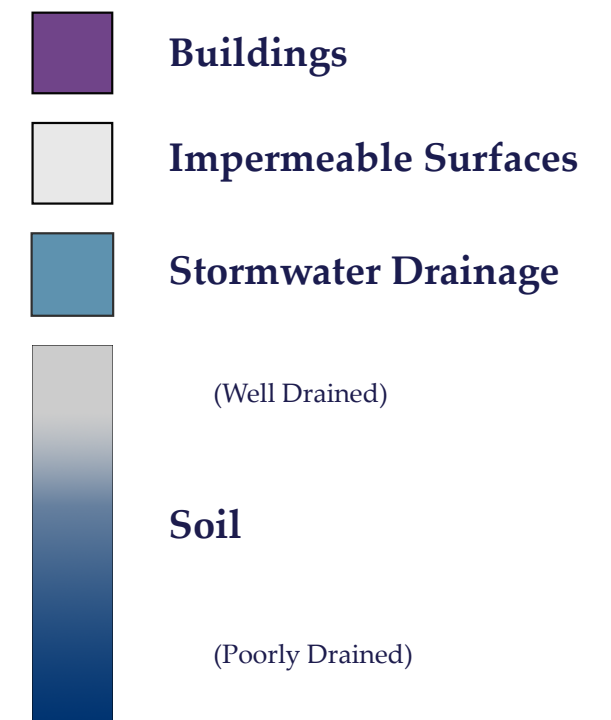
## Site Drainage

The gorge is flanked by heavy development on both sides. Large swaths of impermeable surface including roads, parking, and buildings generate a large amount of stormwater runoff. As the water runs rapidly into the creek down a series of drainage ditches, it creates significant erosion, which could lead to a greater sediment load on the creek. The amount of water flowing through the drainage channels makes them excellent locations for stormwater management features, such as an RSC (Regenerative Stormwater Conveyance). These could help to slow down the water, allowing it to release sediment and other solid contaminants, as well as infiltrate into the ground before flowing into the lake. Channels draining from heavily developed areas are the best suited as they tend to carry more stormwater, as well as more contaminants.

## Soil Drainage Suitability

The map shows that the best draining soil in the gorge is in the southern portion, while the northern portion is made up somewhat to poorly drained soils. This is partially caused by the presence of wetlands.

## Map Legend (Figure 2)



# Site Geomorphology



Figure 3. Factor K

The K factor indicates the susceptibility of the soil to sheet and rill erosion. Values of K range from 0.02 to 0.69. Other factors being equal, the higher the value, the more susceptible the soil is to sheet and rill erosion by water ([websoilsurvey.sc.egov.usda.gov](http://websoilsurvey.sc.egov.usda.gov)).

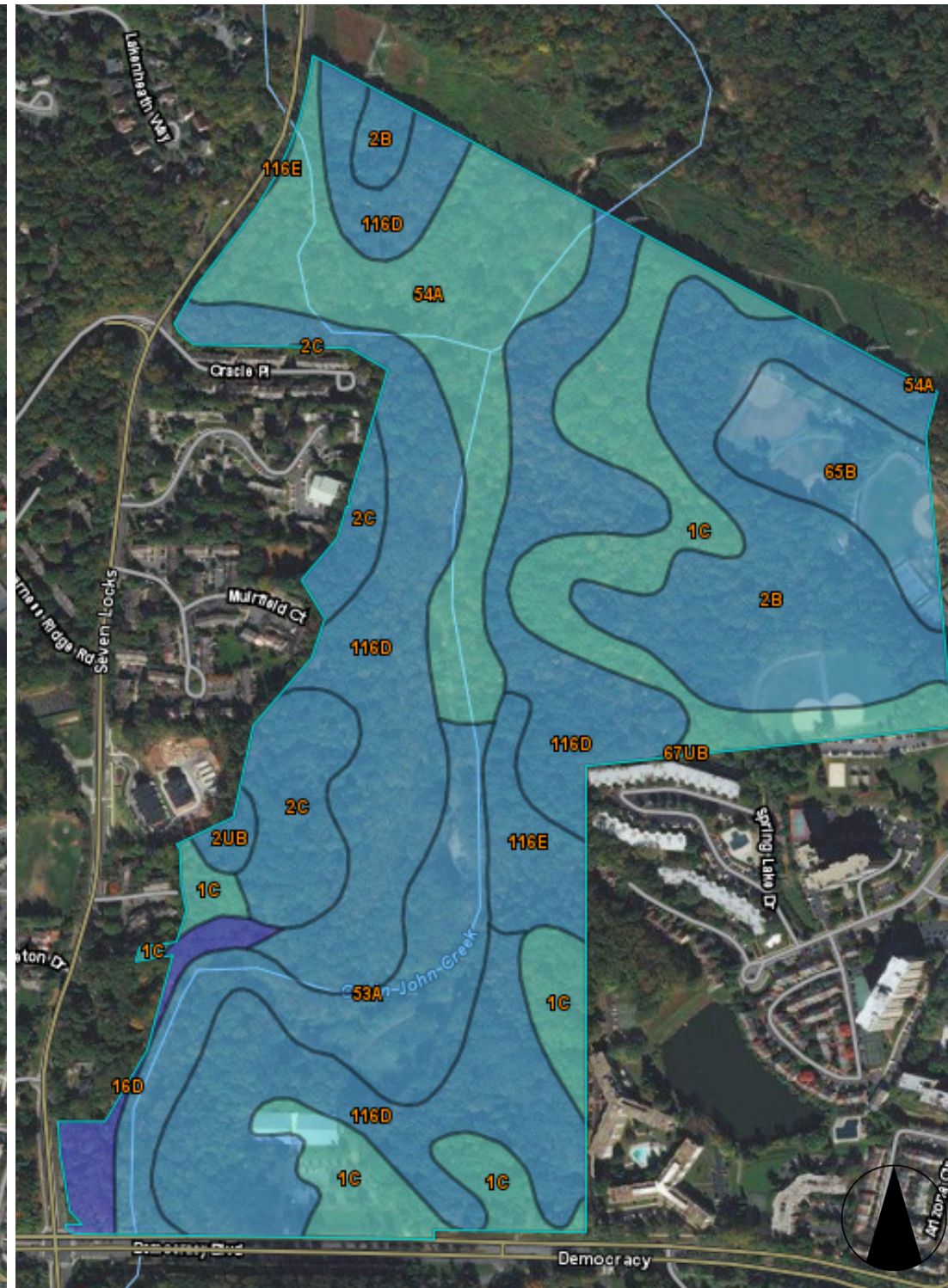


Figure 4. Wind Erodibility Group

Wind erodibility groups (WEG) consists of soils that have similar properties affecting their susceptibility to wind erosion in cultivated areas. The soils assigned to group 1 are the most susceptible, and those assigned to group 8 are the least susceptible ([websoilsurvey.sc.egov.usda.gov](http://websoilsurvey.sc.egov.usda.gov)).

## Soil Erodibility

Soil Type	Description	K	Wind
1C	Gaila silt loam, 8 to 15 percent slopes	.43	5
2B	Glenelg silt loam, 3 to 8 percent slopes	.37	6
2C	Glenelg silt loam, 3 to 8 percent slopes	.37	6
2UB	Glenelg-Urban land complex, 0 to 8 percent slopes	.28	6
16D	Brinklow-Blocktown channery silt loams, 15 to 25 percent slopes	.24	7
53A	Codorus silt loam, 0 to 3 percent slopes, occasionally flooded	.32	6
54A	Hatboro silt loam, 0 to 3 percent slopes, frequently flooded		5
65B	Wheaton silt loam, 0 to 8 percent slopes	.43	6
67UB	Urban land-Wheaton complex, 0 to 8 percent slopes		
116D	Blocktown channery silt loam, 15 to 25 percent slopes, very rocky	.28	6

### Susceptibility to Erosion



# Terrestrial Habitats

## Cabin John Regional Park Maryland's Piedmont

### Basic Mesic Forests

The Basic Mesic Forest wildlife habitat develops over bedrock that weathers to make soils high in calcium and magnesium. Trees common to these rich and moist forests include tulip poplar (*Liriodendron tulipifera*), American beech (*Fagus grandiflora*), black walnut (*Juglan nigra*), northern red oak (*Quercus rubra*), eastern redbud (*Cercis canadensis*) and eastern hop hornbeam (*Ostrya virginiana*).

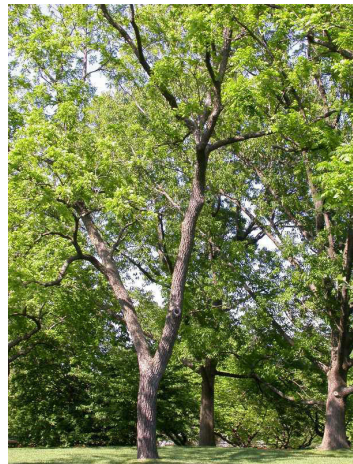


Figure 1. Black Walnut  
(missouribotanicalgarden.org)



Figure 2. Eastern Hop Hornbeam  
(missouribotanicalgarden.org)



Figure 3. Tulip Poplar  
(missouribotanicalgarden.org)

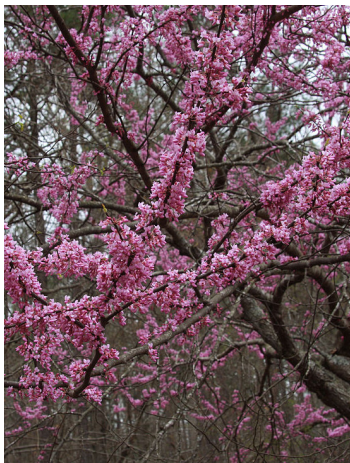


Figure 4. Eastern Redbud  
(missouribotanicalgarden.org)

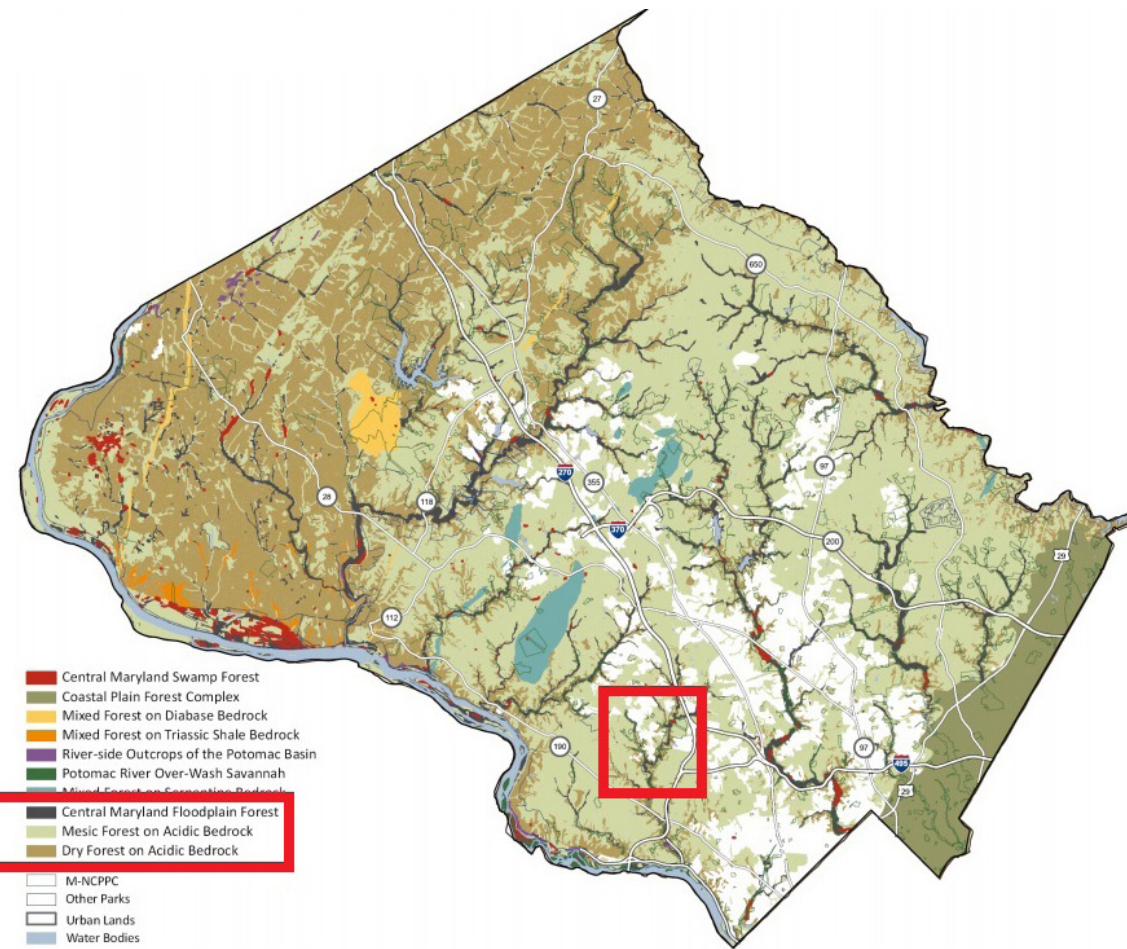


Figure 5. Major Terrestrial Natural Communities (www.dnr.maryland.gov)



Figure 7. Maryland GreenPrint Program Mapping  
(www.dnr.maryland.gov)

## Maryland GreenPrint Program: Implications for Locust Grove Nature Center

### Corridors and Contiguous Forest

Maryland has carefully identified and protected areas that will contribute to the long-term goals of open, continuous corridors of forest for wildlife habitat. Ecosystems along streambeds are some of the easiest and best to include in a corridor system because they are protected from development by their inclusion in the "critical habitats." These critical habitats include streams and streambed buffers, 100-year floodplains, steep slopes, areas of known endangered species, and wetlands.



Figure 6. "The Grand Daddy" Sycamore  
This outstanding specimen in the flood plain along the Cabin John stream is a beloved site for gathering and evening open campfires.

### Floodplain Forests

In the Piedmont, non-tidal rivers and stream floodplains can be temporarily and intermittently flooded. These bottom land forests consist of sycamores, silver maple, and boxelder. Along smaller streams sugar maple, basswood, and white pines can be found. This habitat has been used for agriculture through Maryland's history and is threatened by dams and invasive species.



# Terrestrial Habitats

## Managed Grasslands

Prior to European settlement, acres of grassland covered northern Maryland. Much of this grassland ecosystem has been lost to development, agriculture, and the lack of grazing animals. Managed grasslands are now, for the most part, active pastures and fallow fields where species are both native and nonnative. Cabin John is the site of former agricultural land and if the meadow areas are not grazed, mowed or burned, the grassy areas will naturally succeed to shrub land and then forest within 10-20 years.

Montgomery County Parks is seeking to maintain open habitat areas with various stages of succession with the goal of encouraging species diversity.

Ecotones (the border between different habitats) are especially important because some species are known to be “edge” species. A meadow consists of warm season grasses and native wildflowers, and are important habitat for bluebirds, meadowlarks, bobwhites, and box turtles.

Grasslands are disappearing in the Eastern U.S. Areas of 100 acres are needed to support the breeding of some grassland birds, but 25 acres may be enough if the areas are one-half mile apart or less. Even smaller areas of grasslands are home for feeding and nesting to many species.



Figure 8. Locust Grove Nature Center Lower Meadow

## Basic Mesic Forest Species of Conservation Need

- Big brown bat
- Delmarva fox squirrel
- Smoky shrew
- Many other bats
- Northern bobwhite
- Wood thrush
- Scarlet tanager
- Giant swallowtail



Figure 9. Scarlet Tanager (audubon.org)

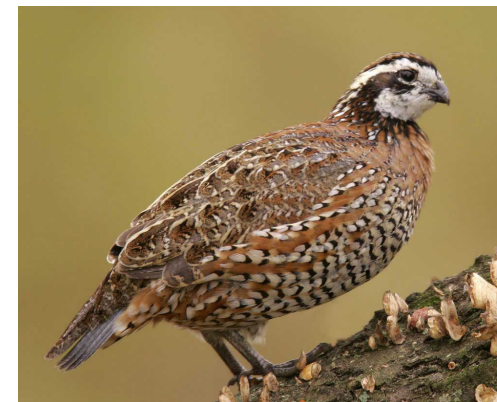


Figure 10. Northern Bobwhite (audubon.org)



Figure 11. Shrew (robinsonlibrary.com)

## Vital Microhabitats in the Forest

- Downed trees (logs)
- Standing trees (snags)
  - 10 species of birds in the Montgomery County Parks are dependent on snags for nesting and foraging
- Exposed bedrock



Figure 12. Delmarva Fox Squirrel (nationalwildliferefugeassociation.com)



Figure 13. Piliated Woodpecker (audubon.org)

# Aquatic Habitat: Maryland Upper Piedmont

## Stream Habitat

Stream habitat is one of the important factors that affect aquatic communities. Stream habitat describes

the quality of the place or environment where wildlife live.

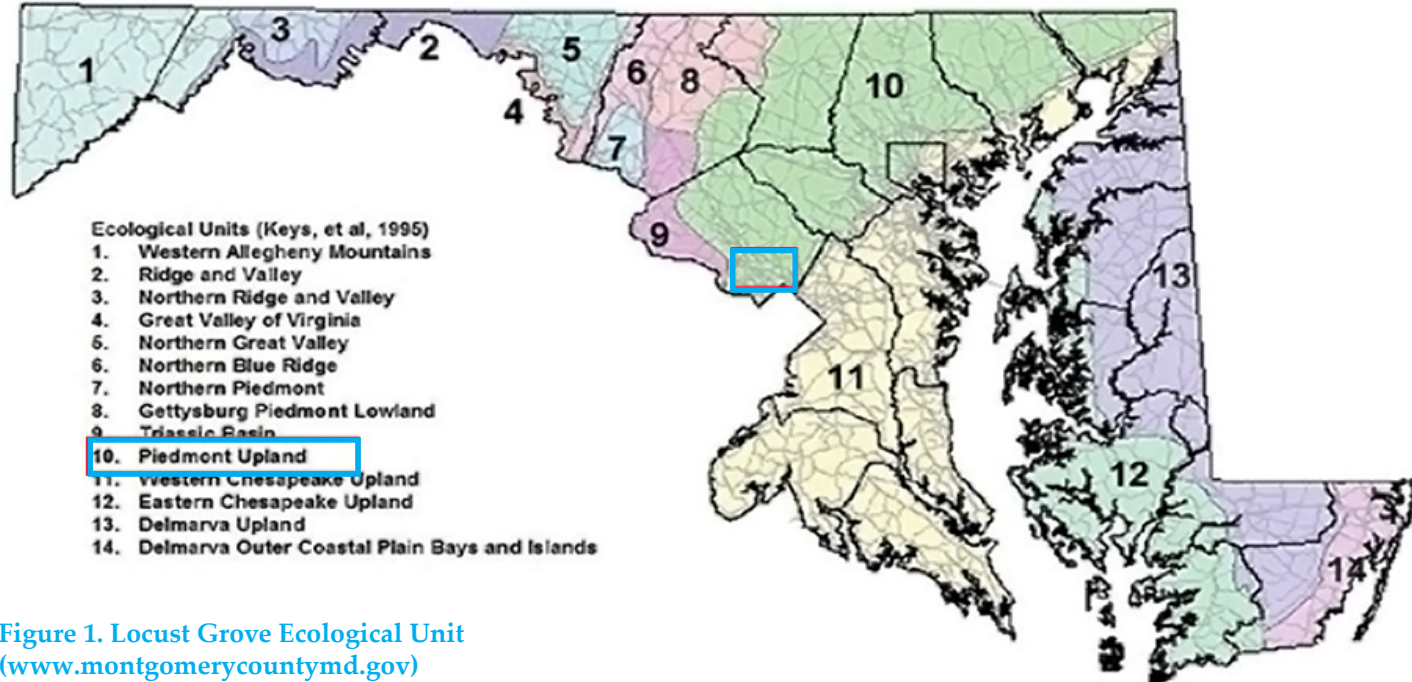


Figure 1. Locust Grove Ecological Unit ([www.montgomerycountymd.gov](http://www.montgomerycountymd.gov))

## Cabin John Watershed

The Cabin John Watershed is located in a densely developed portion of Montgomery County, just northwest of Washington, DC. The main-stem headwaters of Cabin John Creek originate in the City of Rockville and the mouth flows into the Potomac River between the communities of Cabin John and Glen Echo.

## Degraded Stream Habitats

In Montgomery County, poor habitat causes a lack of aquatic species diversity, their poor health, and decreased population sizes. Degraded in-stream habitat often results from uncontrolled stormwater runoff and uncontrolled runoff from intensively grazed or cultivated agricultural land. Other reasons for poor stream habitat include:

- altered stream flows
- excess sediment
- loss of surrounding trees and shrubs that help slow stream erosion
- chemicals and pollutants.

## Effects on The Aquatic Community

Stream habitat affects the aquatic community in many ways.

- Too much sediment can smother bottom-dwelling organisms and communities by filling in the streambed material that the aquatic community needs for respiration and habitat.
- Lack of stream cover can impact fish by removing places for them to hide and rest.
- Lack of clean stream gravel, clean running water, and small pools remove places aquatic organisms need for egg laying and for nurseries for fry.
- Lack of riffles, pools, and runs can impact life stages of aquatic organisms.
- Murky, cloudy water prevents fish from seeing potential food.
- Too much sediment can cover the gills of aquatic insects affecting their ability to respire.

In addition to a stream's habitat conditions, the condition of the adjacent stream banks and stream valley also affect the aquatic community.

- Uncontrolled access by agricultural animals to the stream causes siltation and muddy conditions.
- Lack of trees on the bank can't provide shade for cooler water conditions.
- Stream bank erosion is caused by mowing up to the edge of the stream.

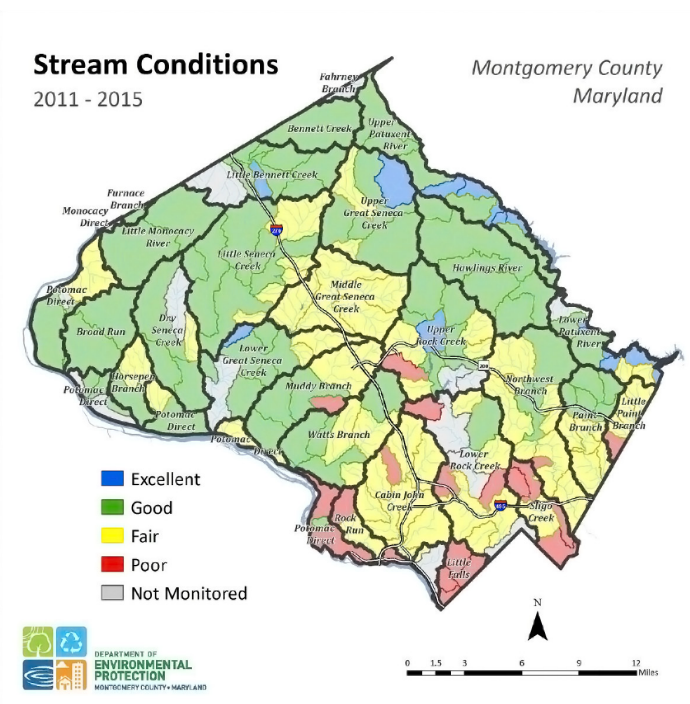


Figure 2. Montgomery County Stream Conditions ([www.montgomerycountymd.gov](http://www.montgomerycountymd.gov))

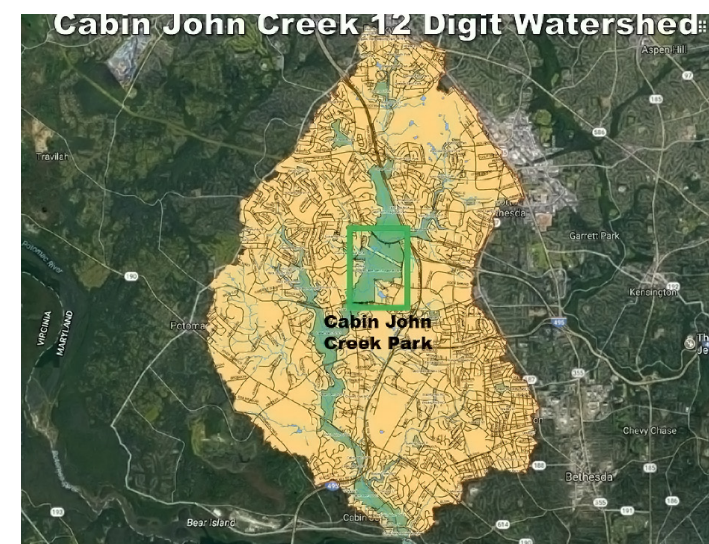
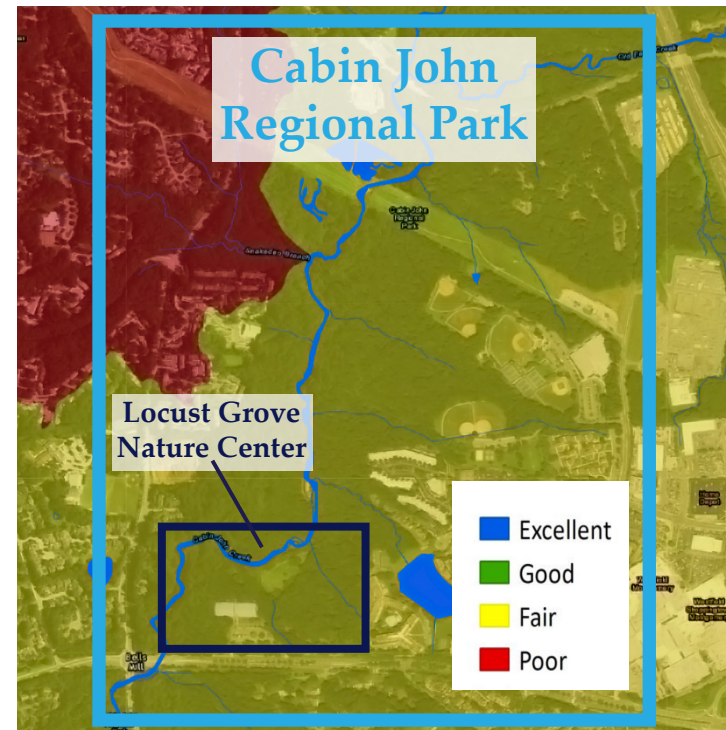


Figure 4. Cabin John 12-Digit Watershed ([www.montgomerycountymd.gov](http://www.montgomerycountymd.gov))

SITE ANALYSIS: Aquatic Habitat

# Aquatic Habitat

## Determining Stream Conditions

**Stream Conditions** are determined by sampling a stream's fish and bugs such as the native species shown here. Fish and bugs live in streams year-round and are subject to changes in water quality or habitat. If conditions are poor, sensitive fish and insects can't survive and won't be found in that stream the following year.

The data from sampling, including the number and types of organisms, are input into an Index of Biotic Integrity (IBI). IBIs are multi-metric (using several measurements) equations that rate a water-body with a unit-less score. These scores can then be used to determine if the stream is in Poor, Fair, Good, or Excellent condition.

- **Poor** stream conditions (a combined IBI score [fish and bugs] of 0-410) most often occur in places where changes made by humans to the natural environment have substantially altered the structure of the biological community. These areas are often highly developed or urban and don't have good stormwater management.
- **Fair** stream conditions (a combined IBI score of 42-63) occur most often in areas impacted by anthropogenic stressors, but that can still support viable biological communities. This condition describes many streams in suburban areas with some stormwater management, as well as areas that have had major agricultural impacts.
- **Good** conditions (a combined IBI scores of 64-88) are often found in the less developed areas, suburban areas with the latest stormwater management techniques, and areas in a watershed with lots of protected land.

**Only Montgomery County's best streams are rated excellent** and must have a combined IBI score of 89-100. Most often only the streams in highly forested

watersheds with minimal development are in excellent condition. These streams are habitat for the most sensitive fish and bugs--fish like trout, shield darters, and comely shiners, and insects including stoneflies and mayflies.

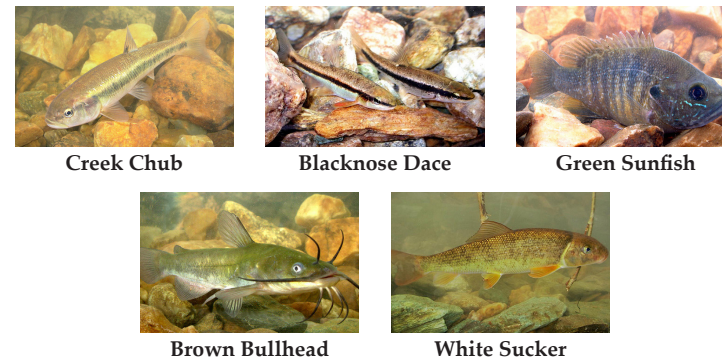


Figure 5. Tolerant Fish Species ([montgomerycountymd.gov](http://montgomerycountymd.gov))



Figure 6. Mildly Tolerant Fish Species ([montgomerycountymd.gov](http://montgomerycountymd.gov))



Figure 7. Sensitive Fish Species ([montgomerycountymd.gov](http://montgomerycountymd.gov))

## Stream Conditions: Fish Species

Montgomery County is home to more than 60 species of freshwater fish, representing nearly every family of freshwater fish known in Maryland. County biologists study fish communities for insight into the health and condition of County streams. The fish are divided into three groups based on their ability to survive in polluted waters. **Sensitive fish** are only able to survive in the County's highest quality streams. **Moderately tolerant fish** can survive and sometimes thrive in areas that receive minor pollution. **Tolerant fish** live in most County streams, but they are the only fish that can survive in heavily polluted waters.

## Stream Conditions: Aquatic Bugs

Montgomery County is home to hundreds of species of aquatic bugs (Benthic Macro-invertebrates). These aquatic bugs process nutrients and energy, powering the stream ecosystem. Because they are crucial to the stream, they are excellent indicators of stream health.

What is a Benthic Macro-invertebrate or Stream Bug?

- A small organism that is visible to the naked eye,
- Does not have a backbone
- Lives on the bottom of streams for at least part of their lives

They include aquatic insects, crayfish, mussels, worms and leeches, snails, sponges, and flatworms.

Why Call them Benthic Macro-invertebrates?

- Benthic = bottom dwelling
- Macro = visible without a microscope
- Invertebrates = lack a backbone

Stream bugs are an important member of aquatic communities. Many stream bugs eat aquatic plants, algae, and terrestrial plants that fall into the water. Those bugs form the base of the food chain and are called Shredders.

Stream bugs are great indicators of stream health, because they:

- live in the water for all or most of their life
- stay in areas suitable for their survival
- are easy to collect
- differ in their tolerance to amount and types of pollution
- are relatively easy to identify in laboratory
- often live for more than one year
- have limited mobility.

Montgomery County categorizes stream bugs into groups based on their ability to withstand pollution. Each genus has a unique tolerance value that helps DEP assess the health of our streams.

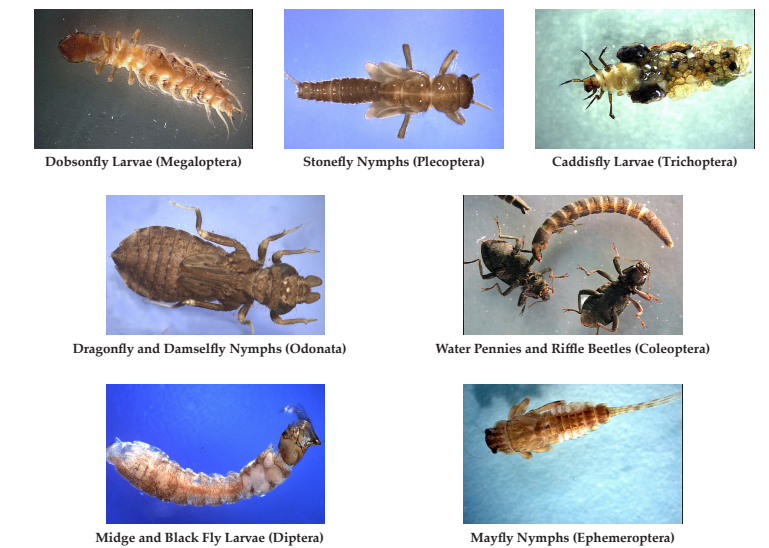


Figure 8. Aquatic Bugs: Common Stream Bugs ([montgomerycountymd.gov](http://montgomerycountymd.gov))



Figure 9. Aquatic Bugs: Non-Insect Groups ([montgomerycountymd.gov](http://montgomerycountymd.gov))

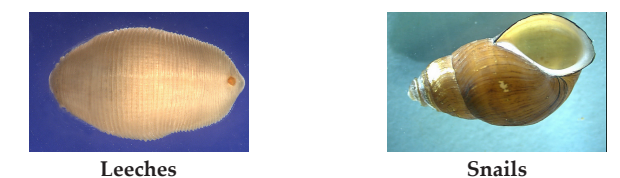


Figure 10. Aquatic Bugs: Worms ([montgomerycountymd.gov](http://montgomerycountymd.gov))

# Neighboring Land Uses

Locust Grove Nature Center is bordered by Democracy Boulevard to the south, Tuckerman Lane to the north, Seven Locks Road to the west, and Westlake Drive to the east.

Locust Grove Nature Center is at the southern end of Cabin John Park, bordering Democracy Boulevard.

Land uses and zoning surrounding the park and nature center includes Agriculture, Hospital, Rural Residential, Residential Detached, Residential Multi-unit, Educational, Commercial, and a Catholic church.

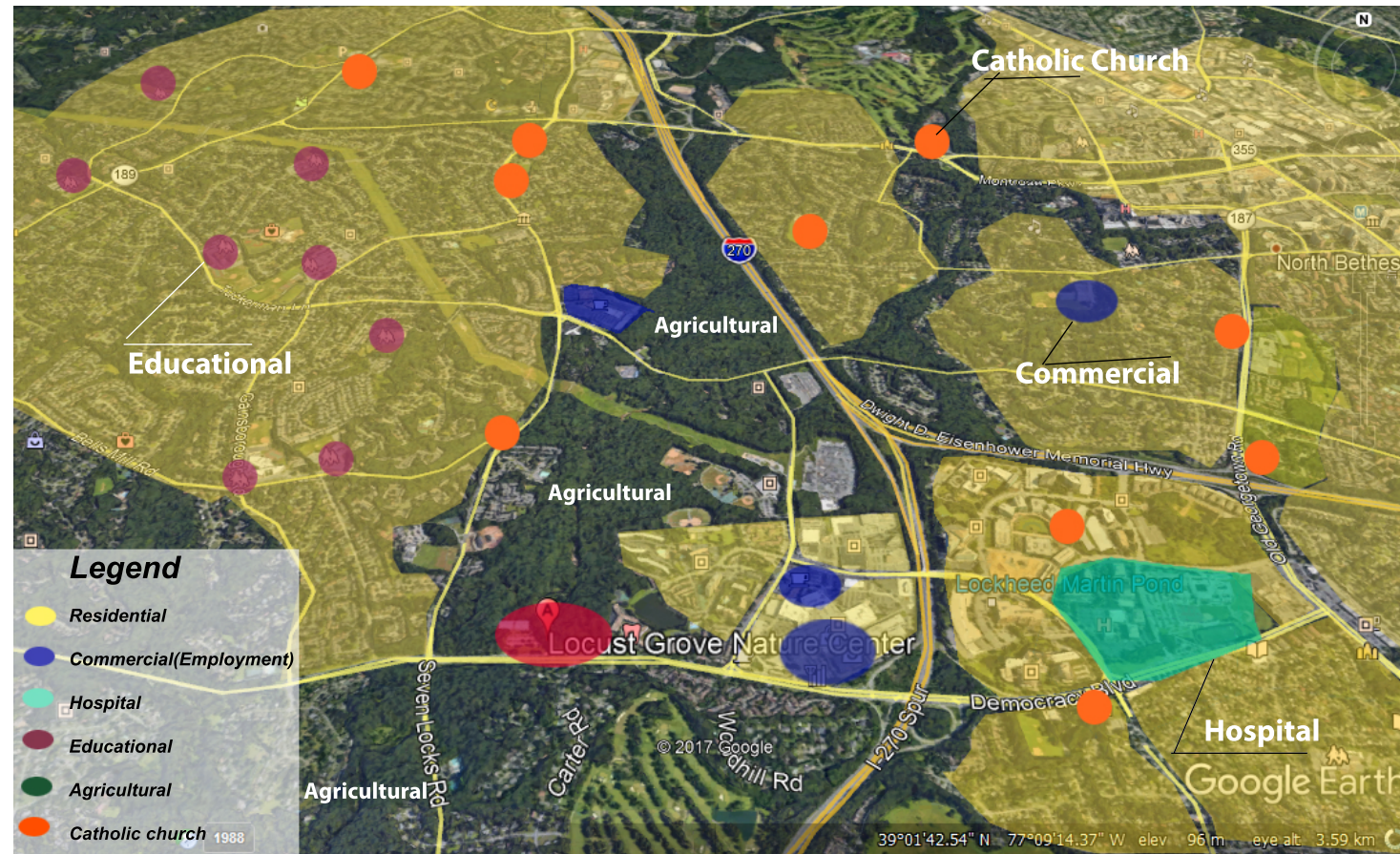


Figure 1. Neighboring Land use (Google Earth)

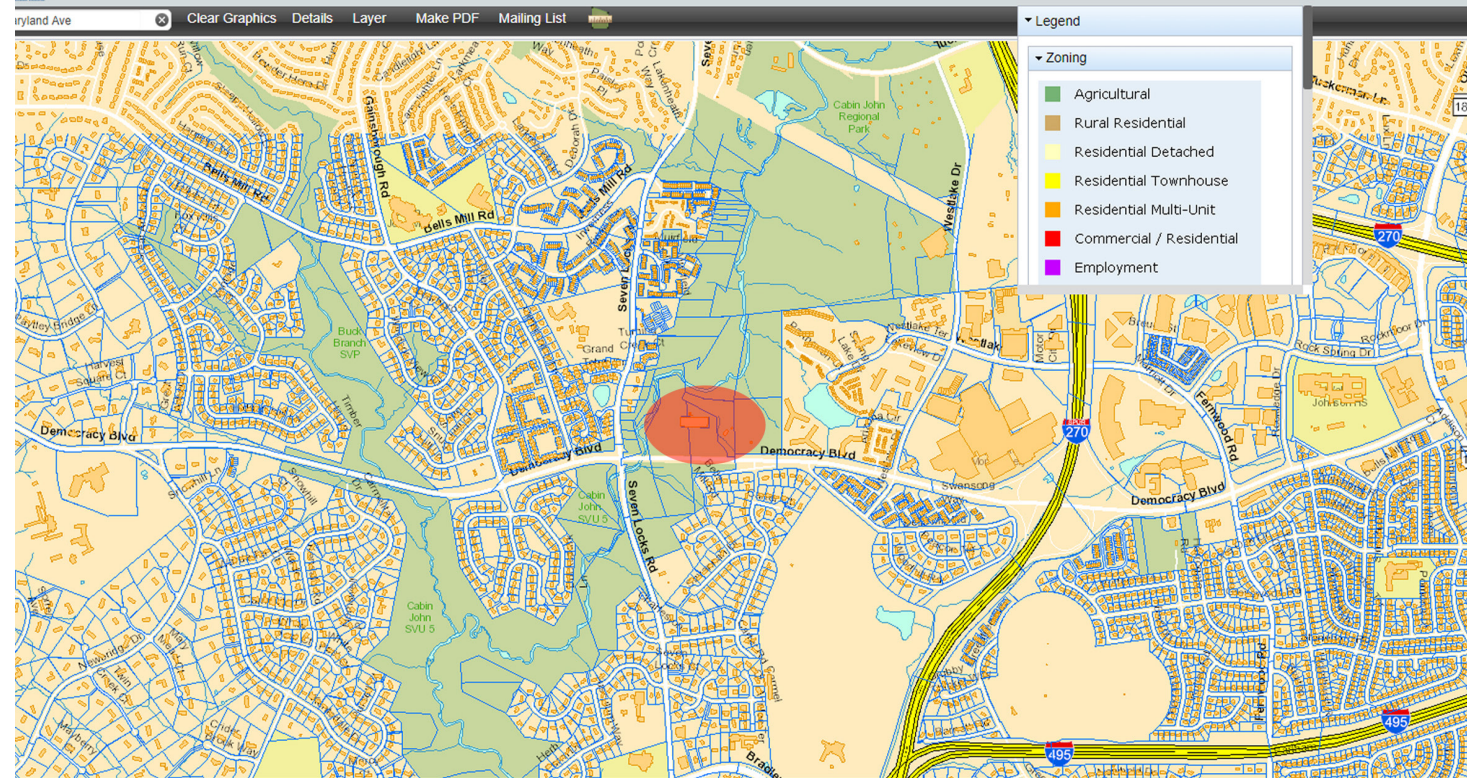


Figure 2. Neighboring land use (Moungomery County Mapviewer)



Figure 3. Park- part of agricultural land use (montgomerycountymd.gov)



Figure 4. Commercial (montgomerycountymd.gov)



Figure 5. Residential (montgomerycountymd.gov)

SITE ANALYSIS: Neighboring Land use

# Interior Land Uses

Locust Grove Nature Center is situated at the southern end of Cabin John Regional Park. The park is operated and maintained by the Maryland-National Capital Park and Planning Commission.

## Cabin John Regional Park

Cabin John Regional Park covers 528 acres along Cabin John Creek, a tributary of the Potomac River. The park offers a wide variety of public activities.

One of the park's primary amenities is a four-mile natural surface trail for hiking and biking. This trail falls within the 8.8-mile long Cabin John Stream Valley Trail that terminates at the stream's confluence with the Potomac River. The trail follows the course of the creek, and connects the rest of the park's amenities.



Figure 1. Cabin John Stream Valley Trail trailhead (montgomeryparks.org)

Cabin John Regional Park has 11 picnic shelters distributed throughout the park, including in the designated Group Picnic Area, which has 40 picnic tables split between two shelters, restrooms, a ballfield with a backstop, three horseshoe pits, a volleyball area, a playground, and sports equipment rentals.

One of the park's most popular amenities is the Athletic Area, which contains five softball fields and a



Figure 2. Cabin John Miniature Train (montgomeryparks.org)

baseball field, which is home to a prestigious summer collegiate team.

Cabin John Ice Rink is accessible from the ballfields and is a hub of activity year-round, with three ice rinks, a dance studio, and three rentable party rooms.

The main park entrance houses the park headquarters and the Cabin John Miniature Train, a favorite seasonal activity for young families. The train traverses a two-mile track that winds through the forest.

The southern half of the park includes the Locust Grove Nature Center and its associated trails, as well as the Pauline Betz Addie Tennis Center.

## Locust Grove Nature Center

Locust Grove Nature Center provides a convenient, tranquil nature getaway in the heart of Montgomery County. The center's trails and creek-access are treasured by the local community.

Locust Grove offers public programs for all ages, including Nature Immersion school programs, a nature preschool program, spring and summer break programs, and naturalist-led walks. Locust Grove is also a popular destination for scout troupes, youth groups, and school groups.

The nature center's exhibits are available for self-led exploration, both indoors and outdoors.



Figure 3. Locust Grove Nature Center provides a wide variety of programming centered on learning about the natural environment and stewardship. (montgomeryparks.org)



Figure 4. One of three rentable fire ring spaces near Locust Grove Nature Center. These are popular for group gatherings year-round. (montgomeryparks.org)

Locust Grove is a popular destination for group gatherings. The center has three separate fire ring spaces with ample seating a short walk from the nature center. These spaces are rented out frequently for evening events and gatherings, including birthday parties.

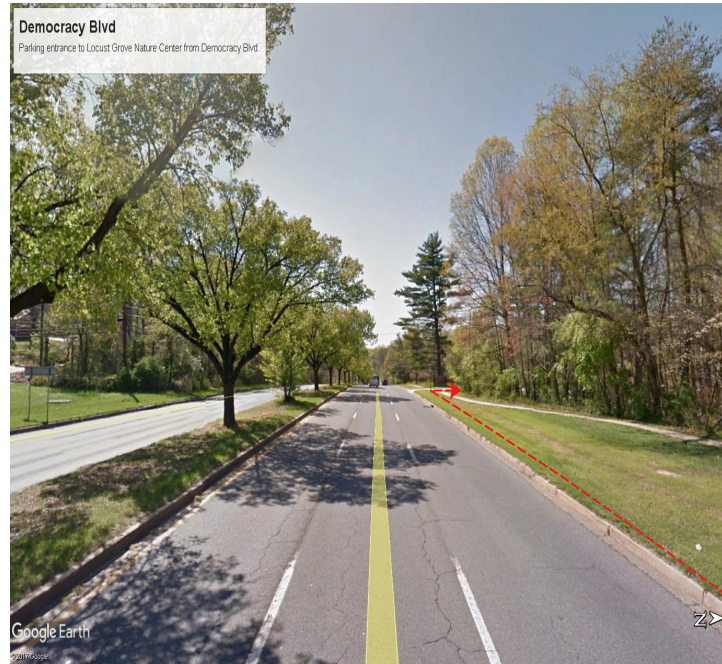


Figure 5. Locust Grove is adjacent to Cabin John stream (montgomeryparks.org)

# Circulation

## Transit Systems

The site's two main local streets and Ride-On bus routes, close to the Inverness Recreation Club, that can connect the community members with the Nature Center. The Red Line's White Flint and Grosvenor Metro stations are close to the site. Democracy Boulevard and Tuckerman Lane have existing parking lots. The site's main entrance is at Democracy Boulevard, so additional parking is more beneficial in this area. The third parking bay can allow seven additional parking spaces upfront, if existing vegetation is moved. Public transit commuters' estimated travel times range from 18 to 46 minutes, during the early afternoon. The local Ride-On buses provide connections to the site. The 42 and 47 buses stop right in front of the Democracy Boulevard entrance, which allows direct pedestrian access to the site. Tuckerman Lane is less inviting because public transit stops are not connected to the park. Even though Tuckerman Lane isn't transit-friendly, it still provides access to Cabin John trails, nearby picnic areas, and adjacent campgrounds.



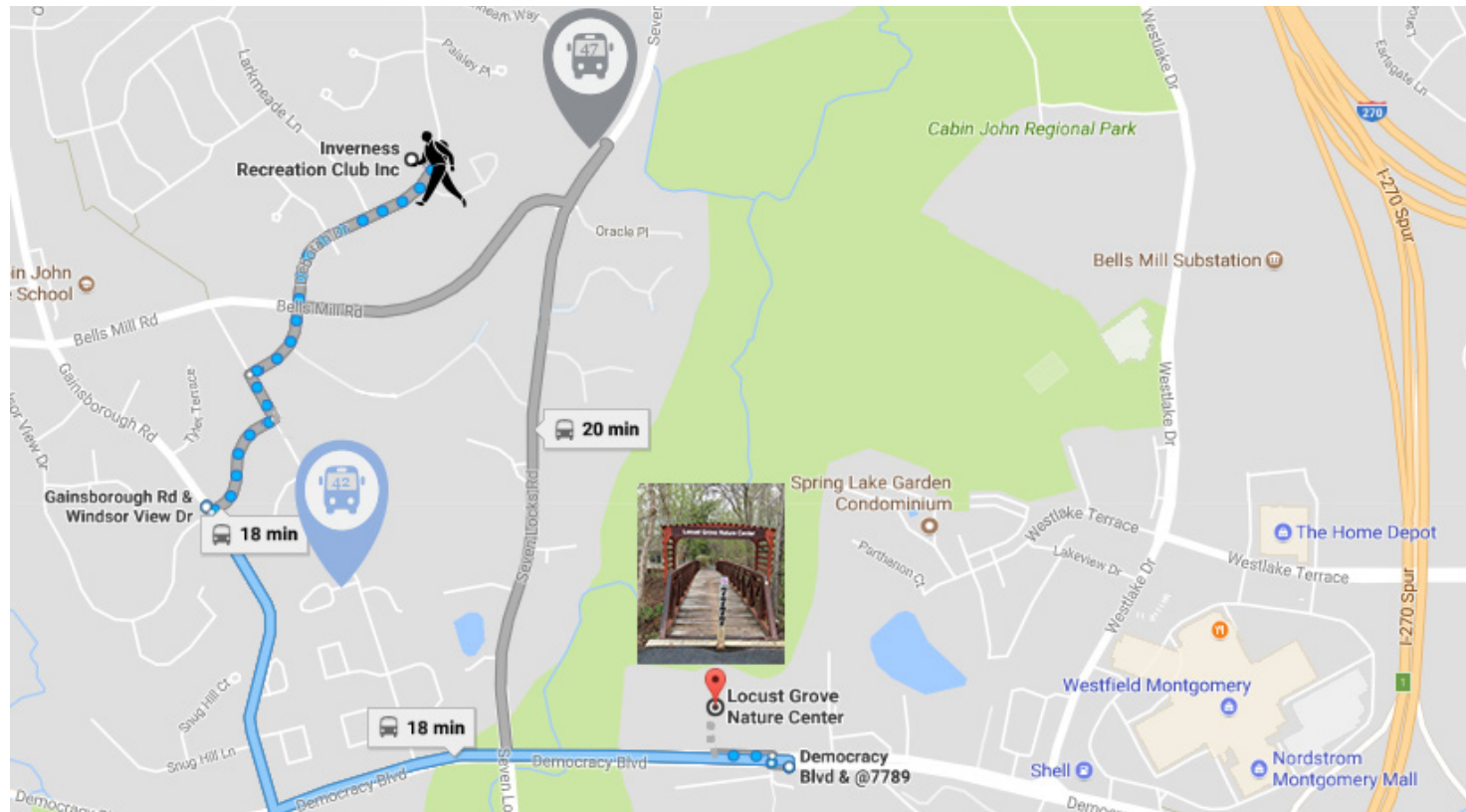
**Figure 2. Democracy Blvd main existing road to site**  
Main local road with shared parking lot to community tennis center and nature center. (www.GoogleEarth.com)



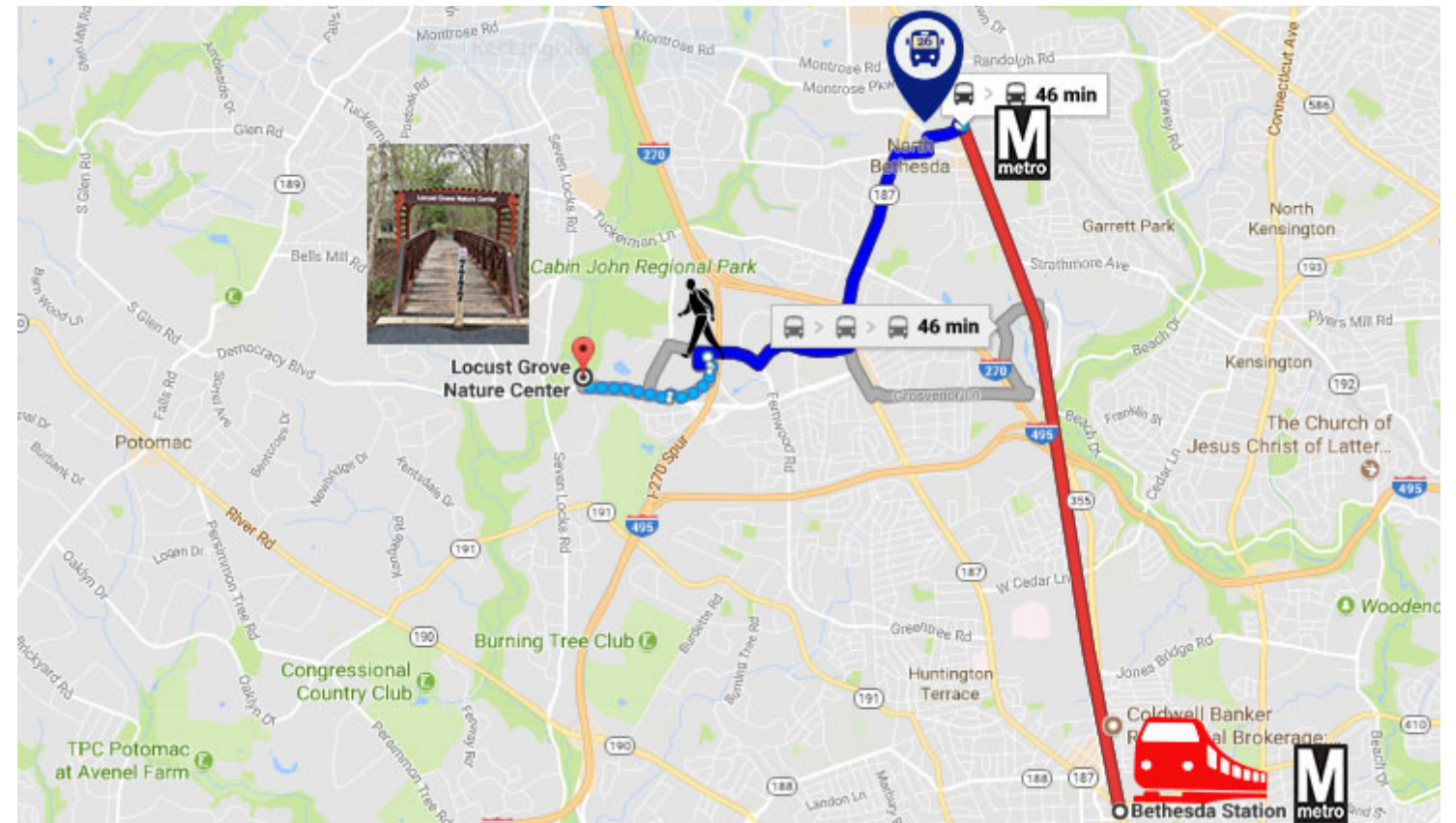
**Figure 3. Tuckerman Road Parking Lots**  
Three of Cabin John's Regional Park's parking lots are placed on opposite sides of Tuckerman Lane. (www.GoogleEarth.com)



**Figure 5. Tuckerman Lane Trail Entrance**  
Trail to Cabin John Regional park from Tuckerman Lane adjacent to Robert C. McDonnell Campground. (www.GoogleEarth.com)



**Figure 1. Bus routes to the site**  
Two local buses: 42, 47 Ride-On. The nearest bus stop is Democracy Boulevard with a five minute walk to Locust Grove Nature Center. (www.GoogleMaps.com)



**Figure 4. Train routes to the site**  
Bethesda metro rail station Redline is the primary connection to the site, but Rockville station is also nearby with a alternate transfer to the 26 bus. (GoogleMaps.com)

SITE ANALYSIS: Circulation

# Circulation

## Roads and Interstates



**Figure 6. Major roads and access points around Cabin John**  
Five local streets surround Cabin John Regional Park, Democracy Blvd, Westlake Terrace, Westlake Drive, Seven Locks Road, and Tuckerman Lane. Access points from motorway I-270. (www.Mapbox.com)

## Trails

Locust Grove Nature Center is easily accessed from I-270 and several major roads. The Cabin John Creek flows along the trails of Cabin John Regional Park. Cabin John has five existing trails and pedestrian-made trails close to Pepco's easement. A new nature trail can be created from the Inverness Recreation Club to the Pine Ridge trail. Cabin John has five existing parking lot connections and one parking lot that is shared with the Pauline Betz Addie Tennis Center. The forest in front of Democracy Boulevard and near Lakeside Terrace condominiums limits the view to the nature center from the local neighborhood along Democracy Boulevard. The forest may need to have trees cut or moved to invite residents who live next door to Locust Grove.



**Figure 7. Existing and Proposed Trails**  
Bike and nature trails around the whole of Cabin John Regional Park, and proposed trail that extends towards the Inverness Recreation Club. (www.ArcGIS.com)







# Site Facilities Standards



# Introduction: Site Facility Standards

Locust Grove Nature Center has many design components that make up the study's proposals. Some design components are governed by regulations or guidelines on how components should be designed. Some of these directions are legal constraints, some are best practices, and some are industry standards.

This section addresses areas of site design where guidance is most directive concerning designed components of the Nature Center site. The standards are reflected in the designs proposed by the Master Plan and in each of the three, more detailed site-specific plans.



### Nature Play Spaces & Safety

#### Maryland Partnership for Children in Nature

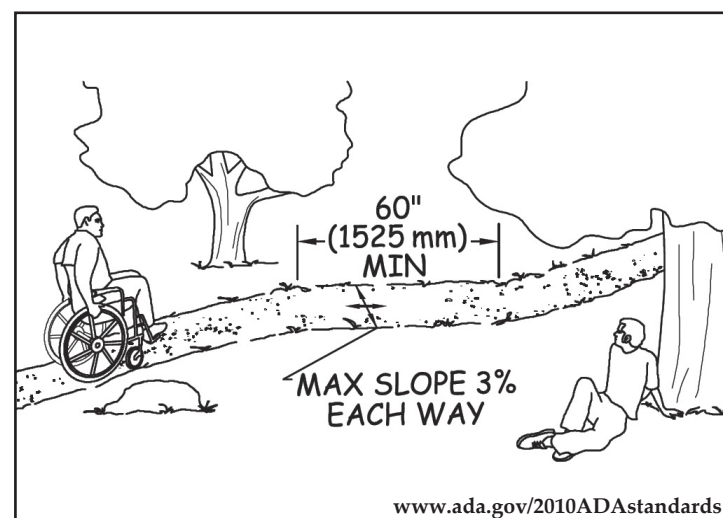
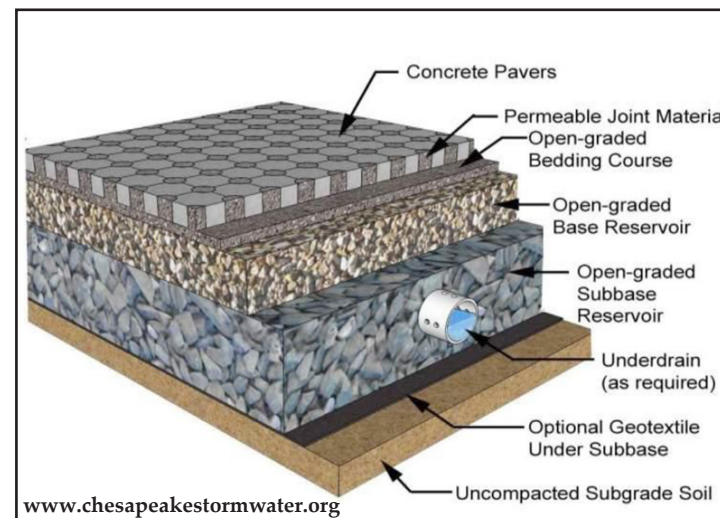
**Applicable Guidelines**  
If you are creating nature play spaces intended for children 12 years old and under, you should consult the U.S. Consumer Product Safety Commission's *Public Playground Safety Handbook*. The CPSC Handbook is available online at no charge at: [cpsc.gov/cpscpubs/pubs/325.pdf](http://cpsc.gov/cpscpubs/pubs/325.pdf)  
In Maryland, compliance with these guidelines is not legally required at the state level. However, some local jurisdictions, insurance carriers, agencies, or others may require compliance with the CPSC Handbook. While design professionals will verify applicable requirements for their clients, those undertaking a natural play space project without professional design

**Important Elements for Nature Play Space Safety and Liability**

- Design the space according to the CPSC
- Conduct regular safety inspections, keep a log of inspections and recommended or completed improvements / repairs
- Consult your insurance policy and if necessary, update before construction of the play area
- Include proper signage - with phone #s, hours etc

**Accessibility**  
The 2010 Americans with Disabilities Accessibility Guidelines became effective on March 15, 2011. The ADA Guidelines for Play Areas are included in this amended version of the ADA. Any new play areas, and many alterations to existing play areas, including those under 1,000 square feet are subject to the ADA. The play area guidelines include access to parking, routes to the play area, and play area amenities such as picnic

www.dnr.maryland.gov



## Table of Contents

Accessibility .....	35
Parking and Access Drive .....	36
Nature Play Spaces .....	37- 38
Wayfinding Signage .....	39
Trail Design and Maintenance.....	40
Stormwater Best Management Practices .....	41-44
Permeable Pavers	
Bioretention	
Green Roofs	
Cisterns	
Pollinator Habitat Considerations .....	45

# Accessibility

## Exterior Accessible Routes

Exterior accessible routes are walkways and pedestrian routes connecting buildings, facilities, and site elements. These routes must comply with the 2010 ADA Standards for Accessible Design and subsequent amendments.

- The maximum running slope is 5% with a suggested 60-inch long landing every 200 feet.
- The maximum cross slope is 2%.
- Minimum walkway width of 36 inches with a 60-inch passing area every 200 feet.
- Walkways intersections must have a slope of 2% or less in any direction.
- All surfaces should be firm and stable, that is, an adult manual wheelchair can be easily pushed and turned on the surface without making imprints.



Figure 1. Illustration of running and cross slope ([www.access-board.gov](http://www.access-board.gov))

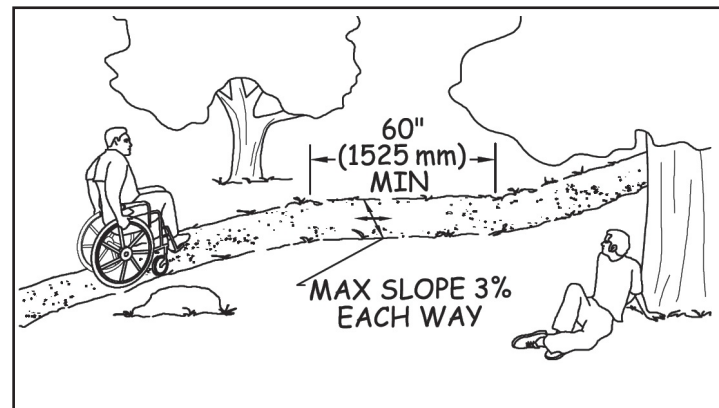


Figure 2. Illustration of a landing ([www.access-board.gov](http://www.access-board.gov))

## Outdoor Recreational Access

ORARs connect more remote sites like campsites, picnic areas, and accessible trail heads and have different design requirements than trails. The accessibility standards allow greater flexibility in maximum slope and landing frequency compared to exterior accessible routes.

- The maximum running slope is 8.3%, with a suggested 60-inch long landing every 50 feet.
- Even steeper slopes, up to 10%, are allowed with a 60-inch landing every 30 feet.
- The maximum cross slope is 3% if the surface is not asphalt, wood, or concrete.
- Minimum path width of 36 inches, which can be a little as 32 inches if there is an occasional unmovable barrier.
- Passing areas 60-inches wide and 60-inches long should be available every 200 feet.

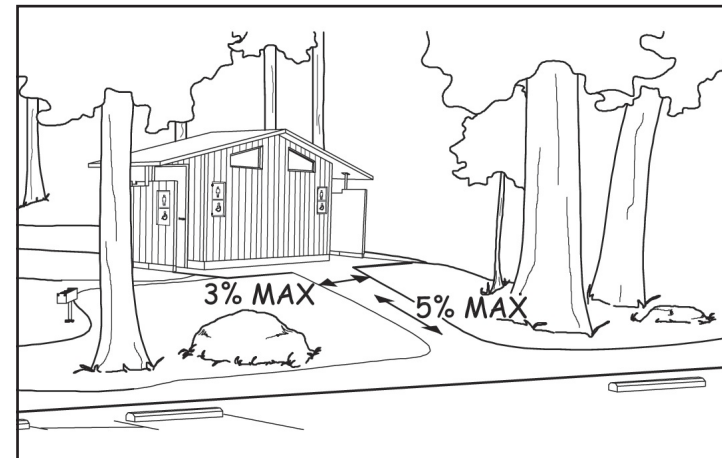


Figure 3. Illustration of an ORAR ([www.access-board.gov](http://www.access-board.gov))

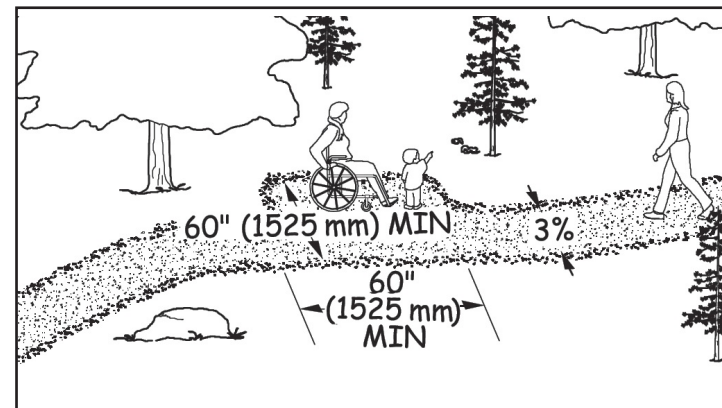


Figure 4. Illustration of a passing area ([www.access-board.gov](http://www.access-board.gov))

## Accessibility Details

Accessibility standards for outdoor spaces include many additional details. A few major examples are listed below.

- Clear spaces for wheelchairs need to be provided at locations such as picnic tables and benches and should be graded at 2% or less.
- Vertical clearance at a minimum of 80 inches.
- Objects protrude into the paths less than 4 inches.
- Roots and rocks protruding from natural surfaces must be less than 1-inch high.
- Protective edges must be 3 inches around the base of elevated walkways.
- If the walkway is elevated more than 30 inches above adjacent ground, a 42-inch high guardrail is required.
- Boardwalk openings must be perpendicular to the direction of travel and a maximum of 1/2-inch wide

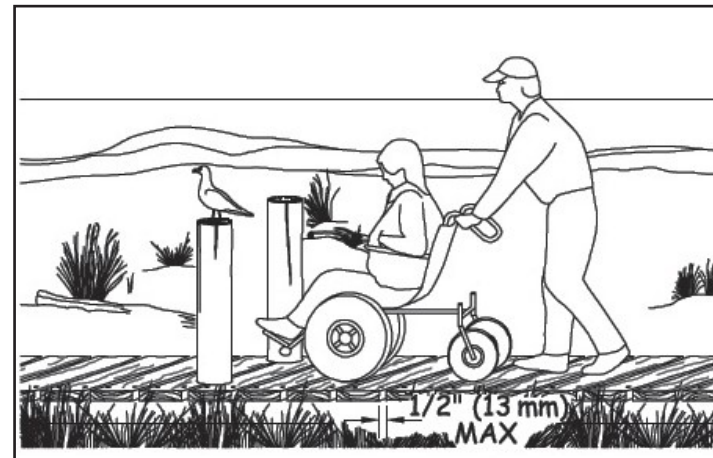


Figure 5. Illustration of boardwalk openings ([www.access-board.gov](http://www.access-board.gov))



Figure 6. Three at the Top!! ([www.access-board.gov](http://www.access-board.gov))



Figure 7. Accessible symbol ([www.access-board.gov](http://www.access-board.gov))



Figure 8. Mom and her kids ([www.access-board.gov](http://www.access-board.gov))



Figure 9. Outdoor recreational access route ([www.lovethebackcountry.com](http://www.lovethebackcountry.com))

# Parking and Access Drive

## Parking facility layout and dimensions

A parking lot is a cleared area intended for parking vehicles. Its surface is designed according to the following standards.

- Parking areas should be related directly to the buildings which they serve.
- Accessible parking stalls should be no more than 30 meters (100 feet) from building entries.
- Drop-off zones should be located as close as possible to primary entryways.
- No grade changes should exist between the road surface and adjacent walkways; vehicular connections to drop-offs, site entrances, and parking areas should be direct. All of these connection points should be graded at 2% or less with no vertical obstructions.
- Site entrances should be well identified with an obvious relationship to the buildings and sites they serve.
- Clear and legible signage should be provided to direct pedestrians to various destinations.
- Each standard size perpendicular parking space shall be a rectangle having minimum dimensions of 8 1/2 feet by 18 feet. A perpendicular parking space is defined as one in which the long side of the space is a straight line that intersects the travel lane and curb at a right angle.
- When fire apparatus access is required to nonresidential uses, the minimum driveway width should be 20'-24' for one-way and for two-way traffic, respectively. Otherwise the minimum driveway width for a one-way driveway shall be 14 feet. Where one-way drives exist, directional signs and arrows shall be provided.
- All required parking spaces, recreational vehicle storage areas, material storage areas, and associated driveways shall be paved in accordance with design and construction specifications established by the city engineer.

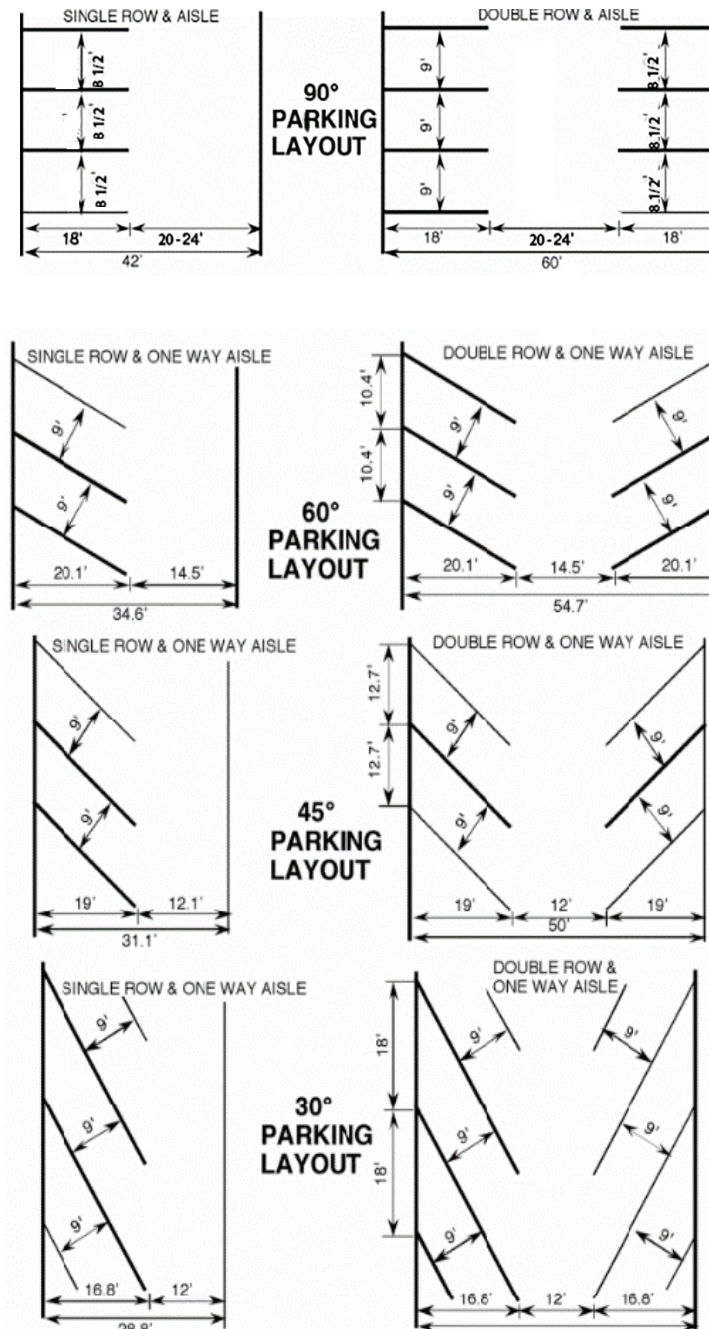


Figure 1. Parking lot layouts at standard angles (Graphic Standards for Landscape Architects; Montgomery County Zoning Ordinance)

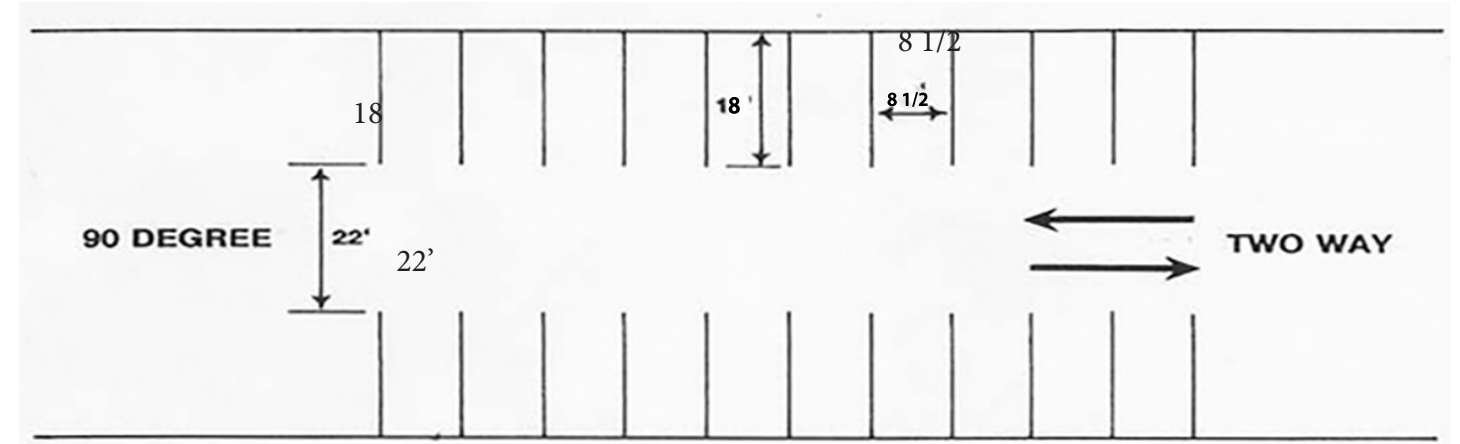


Figure 2. Parking lot standards for one-way and two-way traffic (Montgomery County Zoning Ordinance)

- All required vehicle parking spaces shall be clearly marked with paint or other easily distinguishable material.
- Safe and adequate ingress and egress shall be provided to and from a street, highway or alley. Egress onto a public street shall be in a forward direction with maneuvering permitted in the public right-of-way.
- Any required garage, carport, or parking space located more than 100 feet from the street or highway from which access is taken, and served by a driveway or aisle less than 20-feet wide, shall have an adjacent vehicle turnaround area.
- Lighting of outdoor parking areas shall be designed and maintained to prevent glare or direct illumination from intruding into any adjacent residential zone. A minimum of one footcandle of illumination shall be provided throughout the parking area. Light standards shall conform to design specifications as determined by the director of public works.

- All areas used for the movement, parking, and loading of vehicles shall be graded to convey surface water consistent with the water quality management plan requirements (if applicable). Drainage shall not be permitted across the surface of walkways or driveways.

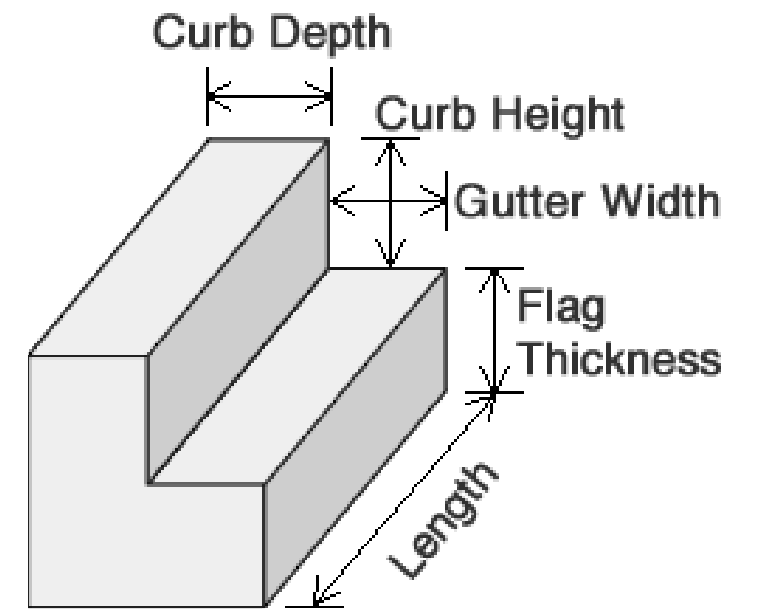


Figure 3. Suggested Curbs used for parking lot area- 6' by 4" (www.calculatorsoup.com)

# Nature Play Spaces

A nature play space is intentionally designed or designated to integrate natural components into a place for structured and unstructured play and learning. A natural play space:

- provides an important early connection for children with nature and creates future environmental stewards
- provides an opportunity for both physical and creative play
- support children's physical, intellectual, and emotional development.

## Physical Components

- Bridges
- Hiding Places
- Plants
- Loose Parts
- Varying Terrain
- Pathways
- Water
- Seating
- Signage



Figure 1. Physical Components ([www.dnr.maryland.gov](http://www.dnr.maryland.gov))

## Activities

- Balancing
- Building
- Climbing
- Connecting
- Nature Art
- Gardening and Digging
- Listening and Observing



Figure 2. Nature Play Activities ([www.dnr.maryland.gov](http://www.dnr.maryland.gov))

## Maryland Applicable Guidelines

Standards for nature play spaces intended for children 12 years old and under, are provided in the U.S. Consumer Product Safety Commission's Public Playground Safety Handbook.

In Maryland, compliance with these guidelines is not legally required. However, some local jurisdictions, insurance carriers, agencies, or others may require compliance with the CPSC Handbook.

## Accessibility Guidelines

The 2010 ADA Guidelines for Accessible Design became effective on March 15, 2011. The ADA Guidelines for Play Areas are included in this amended version of the ADA.

Note the section called, "Unique Play Areas," which states, "A play area is a portion of a site containing play components designed and constructed for children. ... Play components may be manufactured or natural."<sup>2</sup>

Figure 3. Maryland Dept of Natural Resources Guide ([www.dnr.maryland.gov](http://www.dnr.maryland.gov))

## National Access Board

Figure 4. Department of Justice ADA Standards ([www.ada.gov](http://www.ada.gov))

Figure 5. US Access Board Guideline WebPages ([www.access-board.gov](http://www.access-board.gov))

## National Guidelines

**New National Guidelines for Nature Play Areas:** Nature Play & Learning Places is a project of the National Wildlife Federation (NWF) and the Natural Learning Initiative at the College of Design, North Carolina State University. The project was funded by the U.S. Forest Service and the guidelines were developed with substantial assistance from National Recreation and Park Association staff and member agencies.

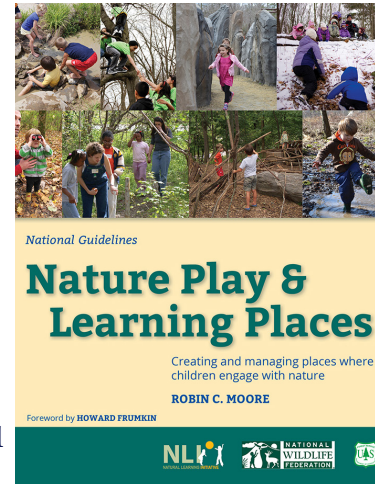


Figure 6. US Access Board "Play Areas" Summary ([www.nrpa.org](http://www.nrpa.org))

## Maryland DNR References CPSC Handbook

U.S. Consumer Product Safety Commission's Public Playground Safety Handbook is suggested as a reference guideline:

...nature play spaces intended for children 12 years old and under, you should consult the U.S. Consumer Product Safety Commission's Public Playground Safety Handbook.

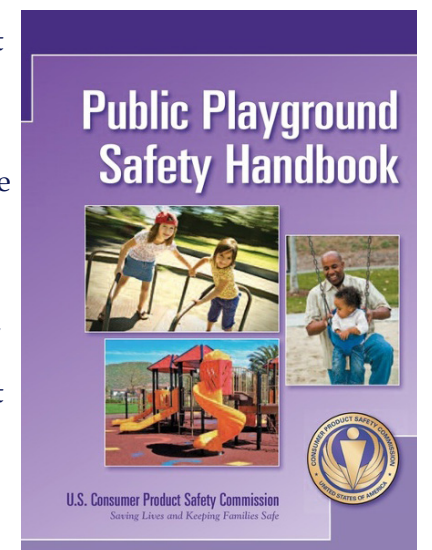
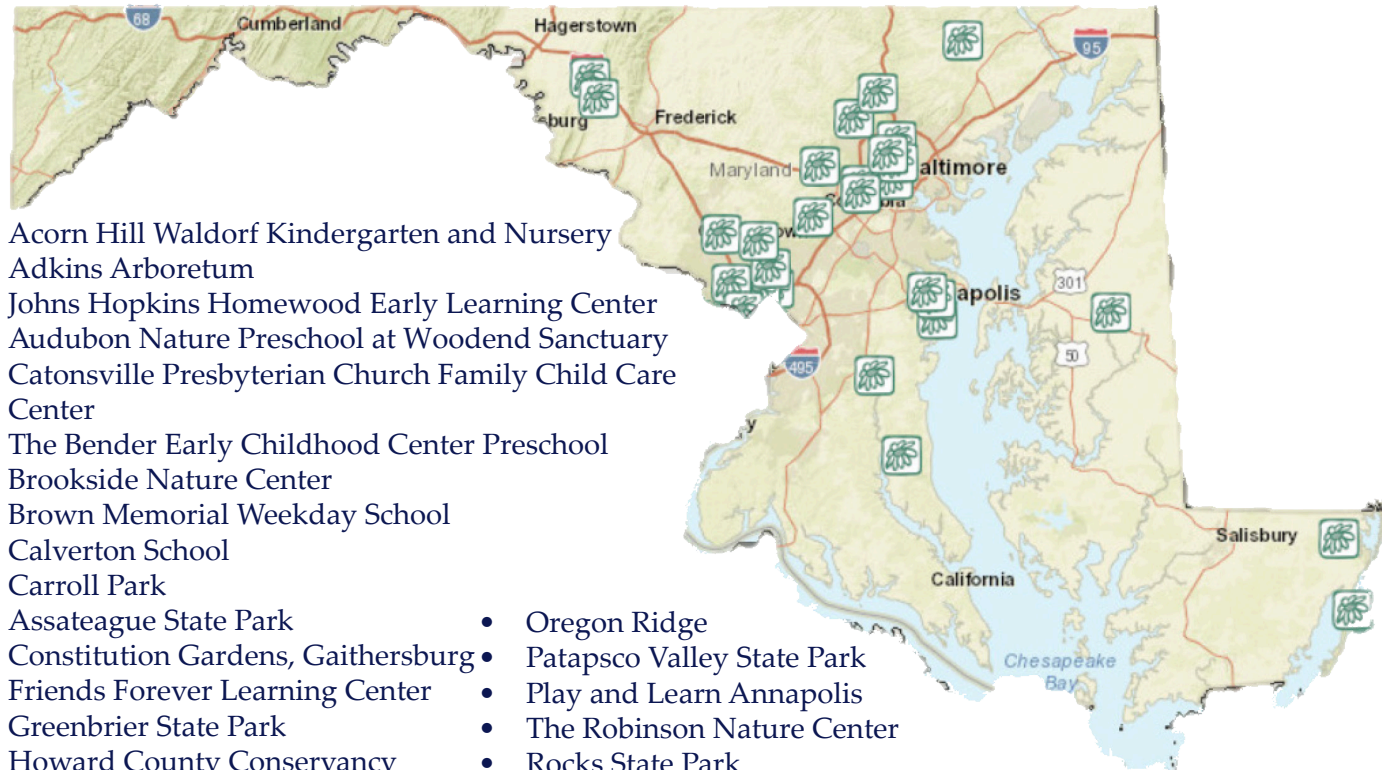


Figure 7. MD DNR Referenced CPSC Public Safety Commission's Handbook ([www.cpsc.gov](http://www.cpsc.gov))

# Nature Play Spaces

## Nature Play Spaces in Maryland



- Acorn Hill Waldorf Kindergarten and Nursery
- Adkins Arboretum
- Johns Hopkins Homewood Early Learning Center
- Audubon Nature Preschool at Woodend Sanctuary
- Catonsville Presbyterian Church Family Child Care Center
- The Bender Early Childhood Center Preschool
- Brookside Nature Center
- Brown Memorial Weekday School
- Calverton School
- Carroll Park
- Assateague State Park
- Constitution Gardens, Gaithersburg
- Friends Forever Learning Center
- Greenbrier State Park
- Howard County Conservancy
- Irvine Nature Center
- Jug Bay Wetlands Sanctuary
- The Key School
- Locust Grove
- Oregon Ridge
- Patapsco Valley State Park
- Play and Learn Annapolis
- The Robinson Nature Center
- Rocks State Park
- Sharre Tefila Preschool
- Tree of Life Nature Preschool
- Waldorf in the Woods

Figure 8. MD Nature Play Spaces ([www.dnr.maryland.gov](http://www.dnr.maryland.gov))

## Maryland DNR Elements

Maryland DNR's website provides examples of nature play space elements:

1. Adventure - physically challenging
2. Fantasy and imagination - challenge and stimulate
3. Animal allies - creating bonds and associations with animals
4. Maps and paths - places to explore
5. Special places - found or constructed places, a bridge between the safety of home and the outside world
6. Small worlds - miniature ecosystems etc.
7. Hunting and gathering - connections to our ancestors and the way we co-existed in nature

These elements can be physical structures such as:

- Seating and quiet places
- Hiding places/tunnels/nooks

- Varying terrain/boulder fields
- Pathways (racing, maze, texture)
- Water features, fire pit areas, and seating

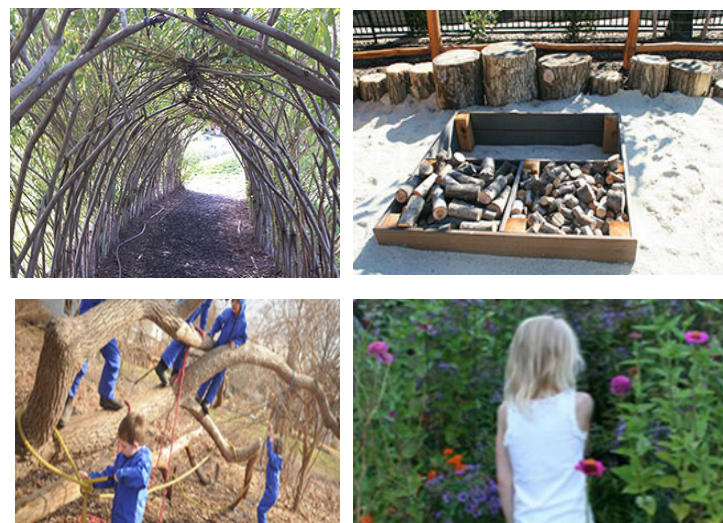


Figure 9. Nature Play Space Physical Structure Examples ([www.dnr.maryland.gov](http://www.dnr.maryland.gov))

## Standard Nature Play Space Components and Activities

A literature review of international, national, and regional nature play spaces provides the following summary of standard general activities, program-support physical structures, and educational tools/aids to support a broad nature play space program for a range of ages.

### General Activities

- Balancing brick building
- Climbing
- Connecting
- Nature Art
- Gardening rake listening and observation
- Sketching and heart
- Music and dance
- Hunting or gathering
- Parent Quiet Spot(s)

### Specific Structural Pieces/Areas

- Entrances: adult and child
- Bamboo or small tree areas
- Hills and berms (even if AstroTurf)
- Cargo net climbing areas
- Climbing walls and trees (vertical/horizontal)
- Waterspouts or pump features, cooking areas
- Maze or labyrinth (movable wood slabs or stone)
- Balance beams or logs
- Fort/tree house, tents and tepees
- Stage performance area
- Gathering/collecting area
- Gardening, bird nests, and bird house areas
- Measuring, maps, and blueprints areas
- Log or post lined paths, foot race areas
- Swings (rope, from trees or structures), hammocks

### Additional Tools and Program Aids

- Rock, shell, pine cone, or seed ID collections
- Mammals and ground creatures keys and aids
- Guides for habitats, food, and physical environs
- Garden exploration: pollinator, herbs, native species
- Butterfly garden/butterfly habitat plants
- Vegetable and edible gardens
- Field and outdoor survival guides for children
- Weather station site
- Earth digging/moving tools
- Day/night exploration items: binoculars, flashlights
- Bug cages, butterfly nets, magnifying glasses
- Paper pads and pencils, art/sketching notepads



Figure 10. Nature Play Space Activity and Tool Examples ([www.dnr.maryland.gov](http://www.dnr.maryland.gov))

SITE FACILITY STANDARDS: Nature Play Spaces

# Wayfinding Signage

Wayfinding constitutes a system of signs, symbols, and landmarks that guide people as they move through a space. A successful system should be straightforward and concise, while reflecting the specific character of the space and its surroundings.

## Wayfinding Design

A successful wayfinding system should have components that reflect consistency and coordination across five categories:

1. Branding
2. Typography and Layout
3. Color
4. Symbols and Maps
5. Materials

## Branding

Branding conveys the identity of a place and is typically driven by a distinct logo. A memorable, influential logo provides a recognizable, cohesive thread to tie the wayfinding components together. Additional branding tools include verbiage, fonts, colors, symbols, and any other associated proprietary brand elements.

All branding elements should indicate what people can expect while they're in the space. Clear branding helps foster a sense of ease when negotiating a space.



Figure 1. Trail branding logo example ([www.stcstorytellers.com](http://www.stcstorytellers.com))



Figure 2. Wayfinding system example ([www.enjoyburlington.com](http://www.enjoyburlington.com))

## Typography and Layout

Text is the main way to convey information to the viewer. The typography should be consistent, legible, and easy to read from varying heights and distances, within reason. The typeface should also be attractive while providing a distinctive essence of the place's character and feel.

## Color

Color is a powerful design tool that has its own language and meaning. Color often transcends language barriers (i.e. green indicates "go" while red indicates "stop"). Color should be chosen carefully so that hues should match the site's intended function and context.

A successful wayfinding system is legible at a glance. The foreground and background colors need to be bold and distinct enough to contrast without distracting from the overall message. The Americans with Disabilities Act recommends a 70% contrast between foreground and background colors.

The Pantone Matching System (PMS) is the most common and comprehensive tool for identifying colors for media. The PMS delineates hue, value, and intensity.

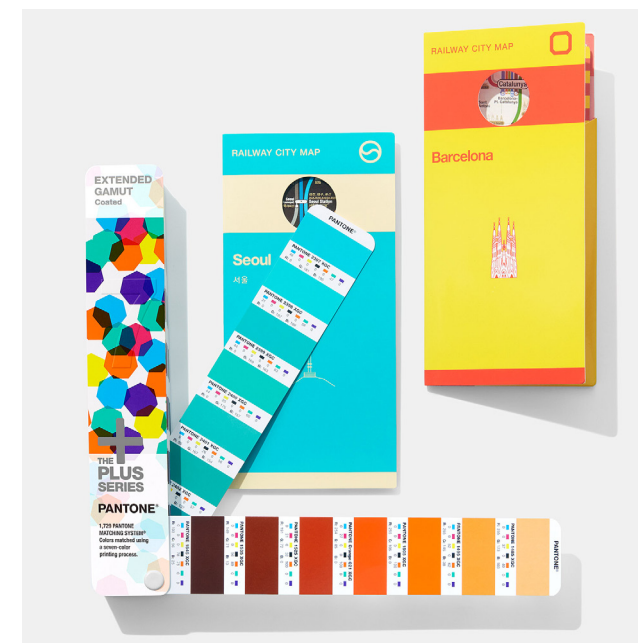


Figure 3. Pantone Matching System guide ([www.pantone.com](http://www.pantone.com))

## Symbols and Maps

Symbols and maps reinforce the information conveyed by text and colors. Symbols integrate to create a universal language that transcends traditional language barriers. While symbols are typically general, maps are site specific. They allow people to orient themselves, show where site features are located, and describe how the site relates to its surrounding areas. A universally accepted pictogram system should be used, like the symbols developed by the American Institute for Graphic Arts.

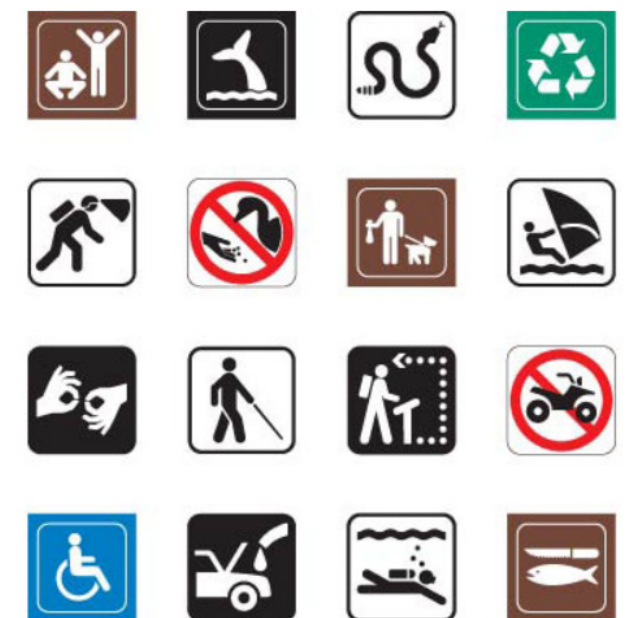


Figure 4. Common recreation symbols ([www.huggamind.com](http://www.huggamind.com))

## Materials

Materials and forms should reflect the character of the site. Although signs will vary in shape, size, and information, a successful wayfinding system comprises a family of signs that share a common graphic and formal language. These signs may be constructed from readily available material. Changing the material form and type for select signs provides a contrast between the signs conveying basic site information and those that convey highlighted features. Locally sourced materials, recycled materials, and local manufacturers should be used when possible.

# Trails and Maintenance



**Figure 1. Nature trail example (www.alltrails.com)**  
Example of a nature trail: Maple Road Trail to Blue Ridge, NC

## Trail Corridors

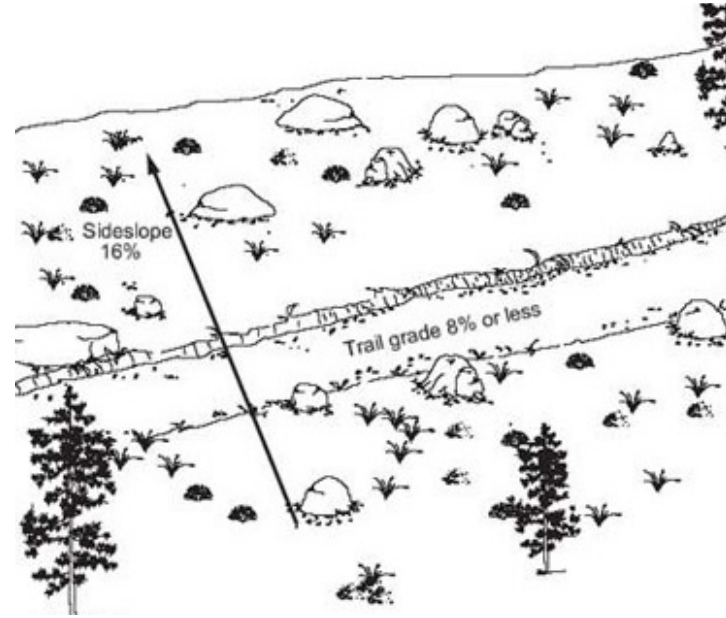
“Trail standards typically define the edges of the trail corridor as the clearing limits. Vegetation is trimmed back and obstacles, such as boulders and fallen trees, are removed from the trail corridor to make it possible to ride or walk on the tread.” (MTDC Trail Construction and Maintenance Notebook)

On level terrain, the corridor is cleared equal distances on either side of the tread’s centerline. Along hiking trails, the corridor is cleared for a distance of 3.3 feet either side of center. Within one-foot of the edge of the tread, plant material and debris should be cleared all the way to the ground. Farther than 1.5 feet from the trail edge, only plants taller than 1.5 feet need to be cleared. (MTDC Trail Construction and Maintenance Notebook)

Rocks, climbing trees, logs, and related materials can be placed near the lower edge of the tread to guide traffic towards the center, but the materials shouldn’t prevent water from draining off the trail. Trees growing within the corridor should be removed because seedlings will grow into pack-snagging trees and are harder to remove. Also, excessively pruned trees should be cut down, carefully so as to not leave pointed stubs. Fallen trees lying parallel to the trail that have trunks outside the clearing limits can be left on the trail, but limbs should be pruned flush with the trunk. Limbing the tree helps the trunk decay quicker. If a leaning tree is within the trail clearing zone, it should be removed. It is recommended that trained and certified sawyers and trail workers remove and cut trees.

## Trail Elements

The half way rule and grade reversals are required to keep sustainable grades and create less maintenance “The half way rule says that the grade should be no more than half the side slope.” (MTDC Trail Construction and Maintenance Notebook)



**Figure 2. Half Rule (www.fs.fed.us)**  
Example of Half Rule: According to the Architectural Barriers Act Accessibility guidelines; federal outdoor developed areas must have accessible trails with the cross slope at 5% maximum.



**Figure 3. Switchback (www.exploresquamish.com)** Switchbacks are ideal for mountain bikers and hikers. This trail element works well with vegetation and rocks along the tread to reduce the occurrence of users from cutting through ecologically sensitive areas.

Grade reversals via switchbacks and climbing turns are used to reverse travel direction on hillsides, to gain elevation quickly, and to keep water off turning trails.

Switchbacks are typically used in steep terrains, usually more than 15%. Side slopes ranging from 15 to 45 % are ideal switchback locations. Switchbacks with side slopes up to 55%, require retaining structures. Natural platforms are recommended for switchbacks because they reduce the cost of fill and excavation needed in future maintenance. Usually, the greater the turning radius, the wider the platform, or flatter the turn, which requires more excavation. When constructing the approach on switchbacks, the last 65 feet of turn should be as steep as the desired level of difficulty will allow, to avoid flattening the grade, and to make sure to keep it smooth enough to connect the turn from 6 ½ to 10 feet. For turns below the upper approach grade reversals, the tread should be 19 to 39 inches wider than the approach. The design should also consider placing rocks or other obstacles between the trail’s grades to help reduce users cutting through. Y-shaped platforms or smooth radius turns ranging from 5 to 10 feet are best suited for hikers.

Climbing Turns have a wider turn radius (13 to 20 feet), which serve as an advantage to switchbacks and are used on gentle slopes, usually 15% or less. The best slope grade for climbing turns is 7%. It is also best not to build these turns in sets on open hillsides except if

they’re very steep terrains. This trail element should be built among dense bushes and trees, and when terrain or vegetation screens the view of travelers coming from upper approaches to the turn. Climbing Turns are also less expensive than switchbacks because they require less excavation and fill is not used.

## Bridges

There a variety of trail bridges including from a simple foot bridge with a handrail to multiple span, suspended, and truss structures. The Forest Service requires handrails on all bridges, unless the risk of falling off the bridge is minimal or the trail itself presents a higher risk. Native material on simple foot bridges can be difficult to maintain due to rotten wood. Unnatural materials are often imported to avoid clear cutting next to the bridge, and to avoid rebuilding structures made by native material. The Forest Service requires all bridge structures to be inspected by a certified bridge inspector every five years to determine if a bridge should remain open. According to national forests, all bridges require design approval from engineering before construction.



**Figure 4. Arched Foot Bridge (www.inhabitat.com)**  
Example of bicycle and foot bridge, DANS Architects used timber planks and shingles to create this 54 long meter arched foot bridge, Slovenia (Nicole Jewell,2015)

This footbridge would be implemented as a flat foot bridge versus an arched foot bridge for ADA accessibility, and is a great choice for sustainability.



# Permeable Paving

Permeable paving captures and allows stormwater to seep into the ground, reducing stormwater runoff to storm drains, and cleaning stormwater. It consists of a variety of types of pavement. The function of permeable paving is similar to sand filters.

## Surfaces



Figure 1. Concrete Grid Pavers ([www.chesapeakestormwater.net](http://www.chesapeakestormwater.net))



Figure 2. Pervious Concrete ([www.perviouspavement.org](http://www.perviouspavement.org))



Figure 3. Porous Asphalt ([www.ucdavis.edu](http://www.ucdavis.edu))



Figure 4. Permeable Interlocking Concrete Pavers ([www.ucdavis.edu](http://www.ucdavis.edu))

## Components and Cross Section Details

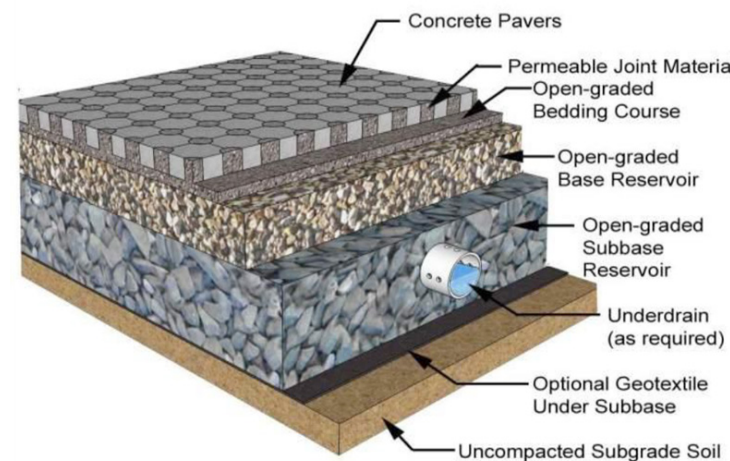


Figure 5. Detail of Permeable Paving ([www.chesapeakestormwater.net](http://www.chesapeakestormwater.net))

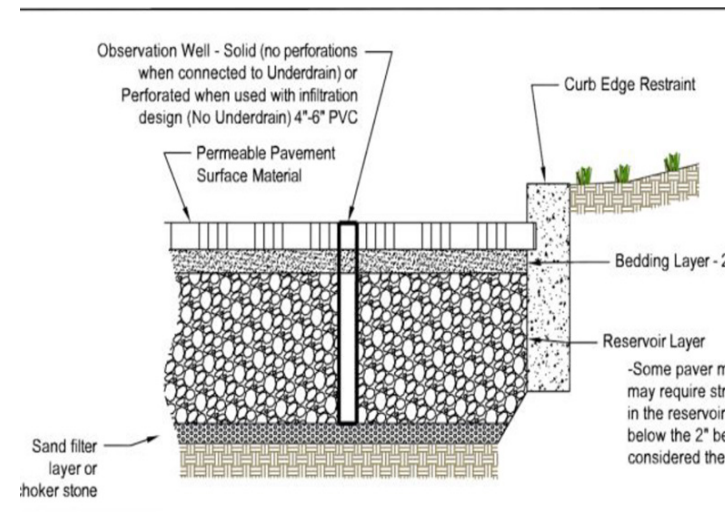


Figure 6. Cross Section of Permeable Paving ([www.chesapeakestormwater.net](http://www.chesapeakestormwater.net))

## Varying Scales/Sizes

Design Factor	Micro - Scale Pavement	Small - Scale Pavement	Large - Scale Pavement
Impervious Area Treated	250 to 1000 sq. ft.	1000 to 10000 sq. ft.	More than 10000 sq. ft.
Typical Applications	Driveways Walkways Court Yards Plazas Individual Sidewalks	Sidewalk Network Fire Lanes Road Shoulders Spill-Over Parking Plazas	Parking Lots with more than 40 spaces Low Speed Residential Streets
Load Bearing Capacity	Foot traffic Light vehicles	Light vehicles	Heavy vehicles
Most Suitable Pavement	Interlocking Pavers	Interlocking Pavers, Porous Asphalt and Porous Concrete	Interlocking Pavers, Porous Asphalt and Porous Concrete

Table 1. Permeable paving components appropriate at three common scales

## Standards

- **Soils:** Permeable paving should not be used in areas of compacted fill or Karst topography. Before installing permeable paving, a soil test is needed to ensure stormwater can infiltrate into soil.
- **Slope:** The permeable paving surface slope should be less than 5%. The bottom slopes of the permeable pavement should be as flat as possible.
- **Setbacks:** Maintain 5-foot setback from sanitary sewer system or other utilities. Do not disturb more than 25% of the critical root zone for trees that have an 8-inch diameter at breast height. Maintain ten feet setback from structures.
- **Minimum Depth to Water Table:** The minimum vertical distance between the bottom of the permeable paving installation and the seasonal high water table is 2 feet.
- **Maintenance:** Permeable paving is susceptible to clogging, so periodic maintenance is required.
- **Planting:** Permeable paving is easily clogged; to reduce this possibility, trees with needles and other evergreen trees should be avoided. Planting beds require frequent mulching.
- **ADA Accessibility:** Most interlocking pavers are ADA compliant.

## Benefits

- **Environmental:** During a heavy rainfall, permeable paving can capture stormwater runoff, reducing runoff entering natural waterways and promoting the infiltration of stormwater.
- **Economic:** Permeable paving can save money on drainage and retention systems.

# Bioretention

Bioretention is a filtration system that treats runoff by passing it through a filter bed mixture of sand, soil, and organic matter. It often refers to a vegetated basin that uses surface storage and plants to treat, detain, and retain stormwater runoff.

The primary component of a bioretention system is the filter bed, which has a mixture of sand, soil, and organic material as a filtering media with a surface mulch layer.

## Components and Cross Details

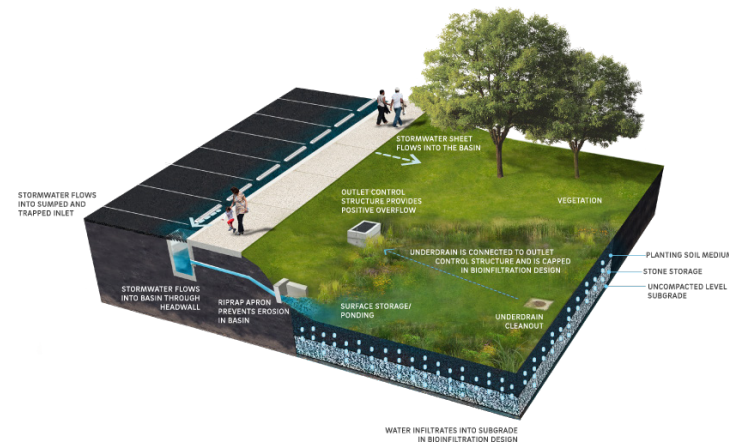


Figure 1. Components of Bioretention ([www.pwdplanreview.org](http://www.pwdplanreview.org))

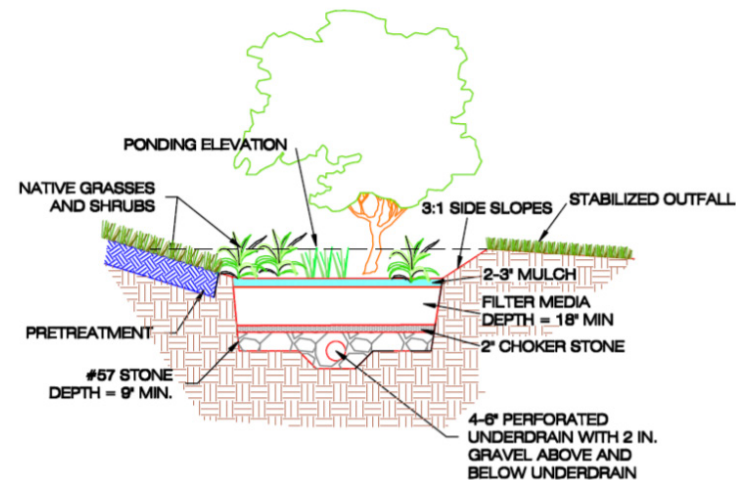


Figure 2. Bioretention Typical Cross Section ([www.ddoc.dc.gov](http://www.ddoc.dc.gov))

## Varying Scales/Sizes

Design Factor	Micro-Bioretention	Bioretention Basins	Urban Bioretention
Maximum Contributing Drainage Area	0.5 acres	2.5 acres	2.5 acres
Typical Applications	Individual rooftops Driveways	Parking lots Commercial rooftops	Expanded tree pits Curb extensions Foundation planters
Vegetations	Turf, herbaceous, shrubs, or trees		
Components of Filter Bed	A mixture of sand(85% to 88%), soil (8% to 12 %), and organic material(1% to 5%) as the filtering media with a surface mulch layer(2 to 3 inches).		

Table 1. Bioretention components appropriate at three common scales



Figure 3. Micro-Bioretention ([www.twitter.com](http://www.twitter.com))



Figure 5. Bioretention ([www.twitter.com](http://www.twitter.com))



Figure 4. Urban Bioretention ([www.portlandoregon.gov](http://www.portlandoregon.gov))

## Standards

### Soils

Soil condition doesn't constrain the installation of bioretention, but it does determine whether an underdrain is needed. Hydrologic Soil Groups (HSG) C or D usually require an underdrain, HSG A and some B soils do not need an underdrain. A soil test is required to determine if an underdrain is needed. If the minimum infiltration rate is greater than 1/2 inch/hour for micro-bioretention and greater than 1 inch/hour for bioretention or urban bioretention, there is no need to install an underdrain.

### Slope

Bioretention is best applied when the grade of contributing slopes is greater than 1% and less than 5%.

### Minimum Depth to Water Table

The minimum vertical distance between the bottom of bioretention and the seasonal high water table is 2 feet.

### Setbacks

Bioretention areas should not be hydraulically connected to structure foundations or pavement, to avoid seepage and frost heave concerns.

The setbacks from a building are based on the sizes of a bioretention system.

### Ponding Depth

The recommended ponding depth is 6 to 12 inches. The maximum depth is 18 inches.

### Filter Bed Depth

The minimum depth of filter bed is 24 inches for bioretention basin and urban bioretention.

The minimum depth of filter bed is 18 inches for micro-bioretention.

### Maintenance

A visible bioretention system requires routine maintenance. During drought seasons, it may be necessary to water the plants.

## Benefits

- Environmental:** Bioretention can improve the quality of stormwater by capturing and cleaning runoff and clean it. It also can provide a habitat for wildlife and native plants, improve air quality, reduce energy use, and mitigate urban climates.
- Economic:** Installing a bioretention feature near a water source can reduce the need for stormwater drainage infrastructure.

# Green Roofs

Green roofs are vegetated layers on top of existing roofs that help intercept and use stormwater, moderate the urban heat island effect, improve air quality, increase usable space, and provide increased insulation. There are no legal standards for most green roof construction, but there are a number of industry best practices that define the necessary layers that can support growing plants and protect the underlying roof from any root or water damage.

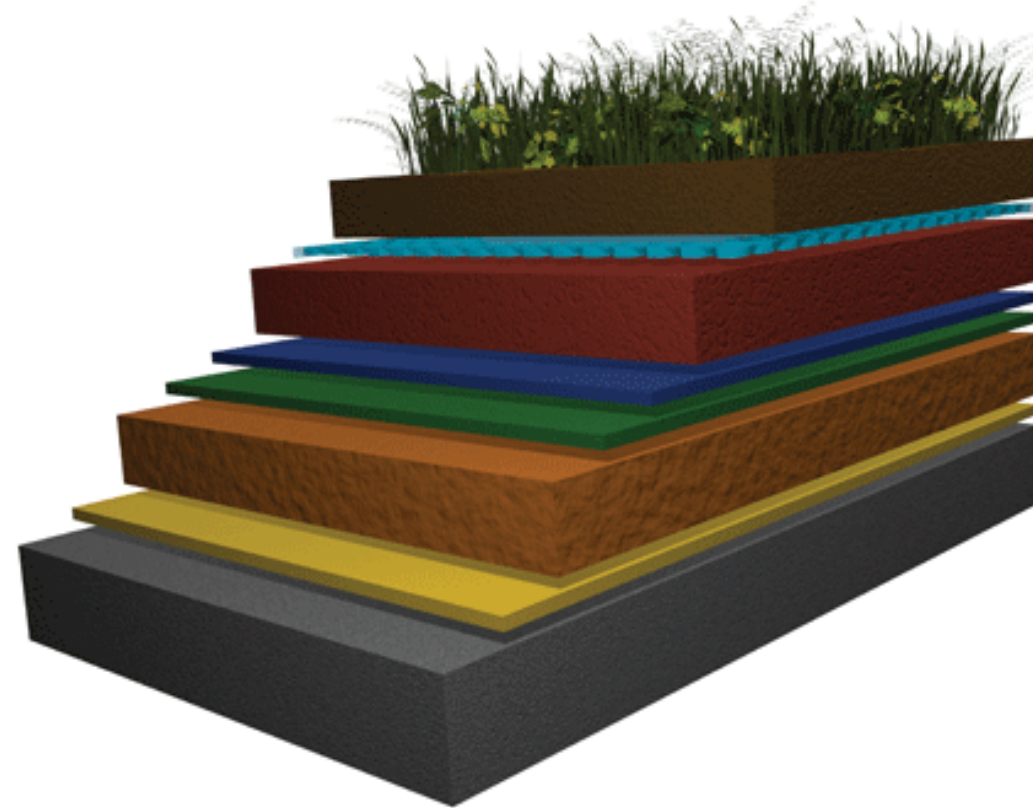
## Intensive vs. Extensive

The depth of a green roof can vary but the two main categories based on depth are intensive and extensive. Intensive green roofs are deeper than 4-6 inches and can support larger, taller plants, even trees. Sometimes a middle category is also defined (semi-intensive). Extensive green roofs are shallower, and typically have no more than 4-6 inches of growing medium supporting smaller plants.

	Intensive	Extensive
Installation Cost	High	Low
Maintenance Cost	High	Low
Plants Supported	Grasses, flowers, shrubs, trees	Grasses, sedums
Irrigation Needed	Yes	No
Use	Ecological protection layer	Garden-like setting
Weight	High	Low



**Figure 1. ASLA Headquarters Green Roof**  
A green roof located on the new headquarters of the American Society of Landscape Architects in downtown Washington, DC. The roof is intensive in some areas and extensive in others. (www.asla.org)



**Figure 2. Typical Green Roof Layers**  
Typical layers that can be seen in a green roof. Layers may vary in any particular roof. (www.nps.gov)

- Vegetation
- Growing medium\*
- Filter membrane
- Drainage layer
- Waterproof/root repellent
- Roofing membrane support
- Thermal insulation
- Vapor control
- Structural roof support

\*Consists of mineral aggregates and a small amount of organic material

## Green Roof Layers

Green roofs are built on top of traditional roofing systems, most often on flat roofs (though sloped roofs can sometimes support them). The layers necessary for a green roof are, from the top down:

- plants
- engineered growing medium (may or may not contain soil)
- landscape filter or cloth to contain roots
- drainage layer with moisture retention
- waterproofing membrane with root repellent
- roof structure

## Engineered Growing Medium

The growing medium for green roofs must support its vegetation while also achieving optimum permeability, water retention, and density so that it is capable of capturing and filtering stormwater without putting too much weight on the roof below. It is not advisable to use native soil or topsoil from a nearby site. Many

mixtures are available from factories or soil experts. The depth of the growing medium (whether the green roof is intensive or extensive) also affects its weight and which vegetation can be supported.

## Waterproofing Membranes

The waterproofing membrane in any green roof is a key element that protects the roof structure from water damage that could be costly and disruptive to repair. Many materials are used for these membranes but all have these traits in common:

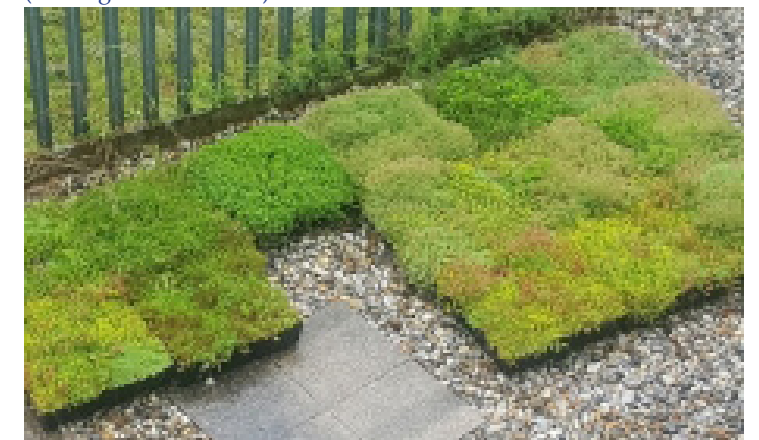
- high puncture resistance
- resistance to chemicals
- low water absorption
- low vapor transmission
- approved for use with ponded water
- pass test for root penetration
- approved for waterproofing in buried applications



**Figure 3. Extensive Green Roof**  
An extensive green roof located at Swarthmore College, Swarthmore, Pennsylvania. Extensive green roofs support smaller vegetation that does not need much water or maintenance, such as sedums. (www.greenrooftechology.com)



**Figure 4. Intensive Green Roof**  
An intensive green roof located at the Baltimore Convention Center. Intensive green roofs support larger vegetation, even trees. (www.greenroofs.com)

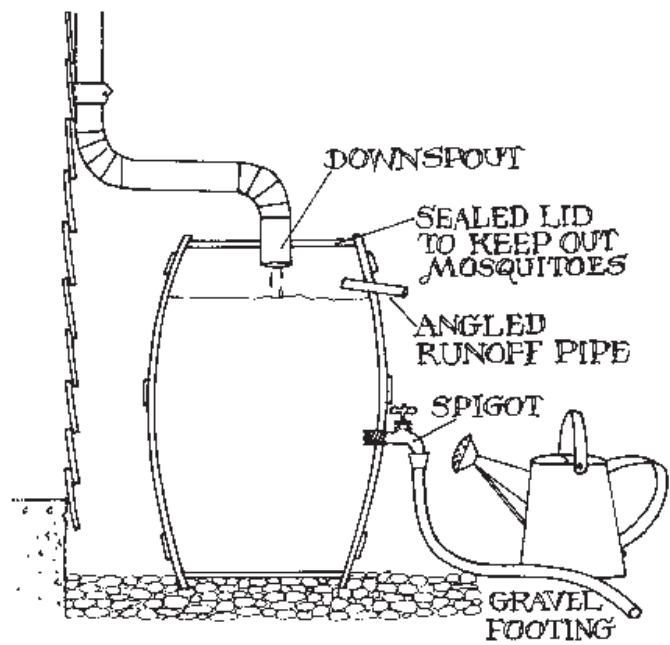


**Figure 5. Green Roof Tray Installation**  
Green roof vegetation can be installed in tray-like pods for easy maintenance. (www.wallbarn.com)

# Cisterns

Cisterns are containers used to capture rainwater from a roof, parking lot, or any other impervious surface. Cisterns can help in reducing stormwater runoff by capturing water on site for later use. This captured water can then be used outdoors for irrigation or indoors for flushing toilets and in other appliances that use non-potable water. Depending on the application, filters and treatment may be necessary. Most captured stormwater is not allowed to be used for potable sources even after treatment.

Cisterns vary in size from small, residential rain barrels, which hold about 50 gallons or less, to large tanks that can hold tens of thousands of gallons or more. In many cases, when collecting stormwater from a large area, several cisterns may be connected to provide additional storage. The cistern size is generally determined by the anticipated water availability and the amount of storage desired. While there are no legal standards for cistern construction, there are several best practices that should be considered for their installation and use.



**Figure 1. Typical Rain Barrel Installation**  
A rain barrel installation and its main features. This type of small cistern is appropriate for residential use and would most likely provide water for irrigation between rain events. (www.lid-storm-water.net)

## Cistern Installation

Cisterns will vary in weight based on their size, and as they fill and empty. It is important to ensure that cisterns have a sturdy base because of this regular weight fluctuation. A good base protects from settling or subsiding of the underlying soil, which could lead to the cistern cracking or overturning. Soil bearing capacity should be considered for cistern locations, especially above ground cisterns. It may be advisable to create a sturdier base of gravel or concrete depending on the size and anticipated weight of the cistern.

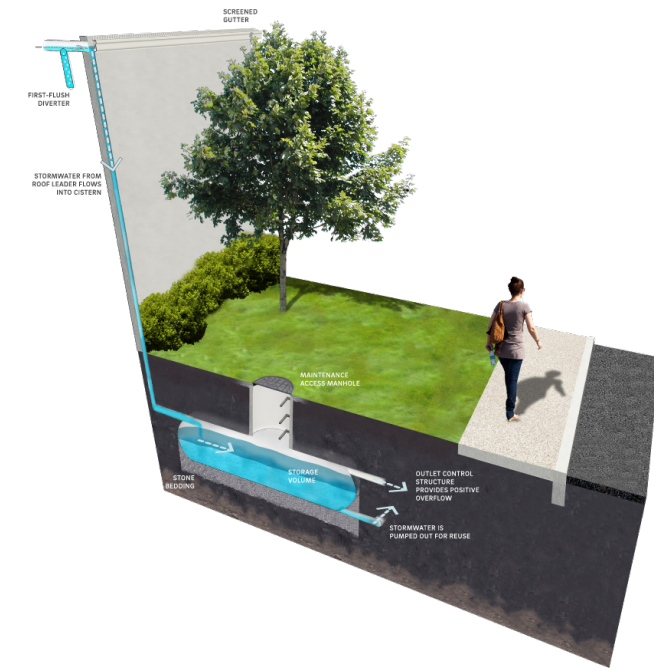
Cisterns should be placed so that water can flow into them via gravity. Those capturing water from a roof can be connected to a downspout that would otherwise direct water over the ground or off site. Cisterns capturing water from a ground surface are typically located underground to receive water via drains and pipes. Water can flow a distance to a cistern if it is desirable to keep the tank itself in a basement.

## Cistern Features

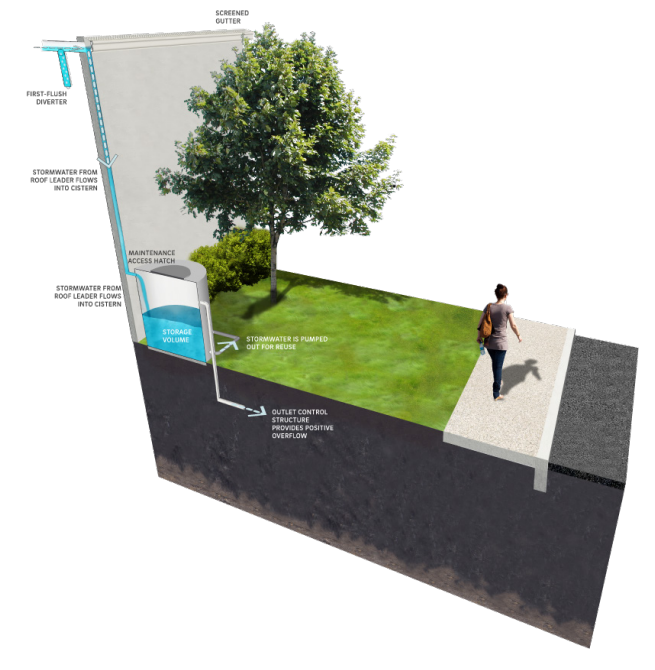
Cisterns can be made of almost any impervious and water-retaining material. While some may be nondescript or even unsightly, there are ways to make them aesthetically pleasing. They can be covered with another material or structure or incorporated into an overall design in a pleasing manner.

Certain features exist to ensure that cistern water is clean enough for use and at an appropriate level within the container. Some cisterns have a first-flush diversion device that redirects the most contaminated water that runs off at the beginning of a storm. At the inlet connection, there is often a screen or grate that filters out larger particulate matter. The lid around this filter should be well-sealed to ensure that animals, insects, or people can't enter the cistern. An overflow inlet is necessary on cisterns in case of a large storm that could result in overfilling.

The cistern outlet will vary based on the cistern's location and the anticipated use of the water. An above ground cistern often has a gravity-driven outlet in the form of a tap at the bottom of the container.



**Figure 2. Sub-surface Cistern**  
A cistern located below the ground surface and its features. (www.pwdplanreview.org)



**Figure 3. Surface Cistern**  
A cistern located on the ground surface and its features. (www.pwdplanreview.org)



**Figure 4. Cisterns in Use**  
Surface cisterns located outside of a building in Philadelphia. (www.pwdplanreview.org)

Below ground cisterns may use pumps to direct water to its desired use. After removal from the cistern itself, water may be directed to further filtration

devices depending on its intended use. These can include sediment traps, filter strips, or chemical applications.

# Pollinator Habitat Considerations

“If the bee disappeared off the surface of the globe, then man would have only four years of life left. No more bees, no more pollination, no more plants, no more animals, no more man.”

-Albert Einstein

Pollinators are very vital to the reproductive processes of many plants, including important agricultural products. Bees are the most productive pollinators, having contributed over \$14 billion of value to US crop production according to a 1999 study by Cornell University. Other pollinators, such as butterflies, hummingbirds, and bats, provide other ecosystem benefits including plant-biodiversity, pest management, and aesthetic appeal.

## Maryland Pollinators



Figure 1. Ruby-Throated Hummingbird (left; [www.commonswikimedia.org](http://www.commonswikimedia.org)); Baltimore Checkerspot (right; Joshua Mayer- [www.flickr.com](http://www.flickr.com))

Maryland is home to a variety of pollinators, most important of which are bees. There are over 400 different species of bees, as well as over 150 different species of butterflies. In fact, Maryland’s state insect is the Baltimore Checkerspot Butterfly. Ruby-Throated Hummingbirds are also a common sight throughout the eastern United States. Other pollinators in this region include ants, beetles, flies, moths, and wasps.

## Habitat Loss & Population Decline

Throughout the United States, populations of pollinators are declining. The exact causes for the declines are not fully understood, but habitat loss and degradation (from deer browsing and/or pesticide use),

and succession of open wetlands to forest or dense shrub land are partly to blame.

## Habitat Requirements

Pollinators need areas to find food, shelter, nesting-sites, and safety from human activities like spraying, tilling, and mowing. Most importantly, they need ample sources of nectar and pollen. At least .5 acres of contiguous habitat is needed for a functioning habitat.



Figure 2. Honeybee ([www.commonswikimedia.org](http://www.commonswikimedia.org))



Figure 3. Monarch Butterfly Pupa ([www.commonswikimedia.org](http://www.commonswikimedia.org))

## Maintenance

Pollinator meadow habitats are fragile ecosystems, so maintenance must be done carefully and regularly. Mowing, burning, or herbicide applications must be conducted outside of the nesting season, usually between May and July. Invasive and successive species must be removed, especially during the first few years while the flowering plants and grasses are becoming established.

## Plant Material



Figures 4-5. Wildflower species



Figures 7-8. Wildflower species

4. *Aclepia tuberosa* - Butterfly Milkweed ([commons.wikimedia.org](http://commons.wikimedia.org))
5. *Pychnanthemum* spp. - Mountain Mint  
Cyndy Sims Parr - ([www.flickr.com](http://www.flickr.com))
7. *Eutrochium fistulosum* - Joe Pye Weed  
Liz West - ([www.flickr.com](http://www.flickr.com))
8. *Chelone glabra* - White Turtlehead ([commons.wikimedia.org](http://commons.wikimedia.org))



Figure 6. Wildflower Meadow ([www.commonswikimedia.org](http://www.commonswikimedia.org))





# Master Plan + Site Designs



# Master Plan

## Introduction

Cabin John Regional Park is a 525-acre green oasis in the southwestern corner of Montgomery County offering recreational, athletic, and educational opportunities. This master plan for the Cabin John Park focuses on creating **greater awareness and access** to the Locust Grove Nature Center, a small area at the park's southern border. This Nature Center currently provides summer programs for school age children, educational nature tours, exhibits, evening campfires, and other activities. Bringing more visitors to a new, expanded and enhanced Locust Grove Nature Center will allow more County residents to share the serenity, beauty, and wonder of this special place.

Opportunities to increase **awareness** of the new Nature Center include:

1. Creating bold, new signs at the park's other well-used sites as well as on Democracy Boulevard
2. Designing and building a large, new Nature Center and placing the building in view of the road
3. Adding unique programming and activities to the new Nature Center to draw in the public

Opportunities to increase universal **access** to the new Nature Center include:

1. Building an accessible walkway from the neighborhood west of Seven Locks Road, allowing safe crossing at the intersection of Bells Mill Road, through the park to a new bridge crossing Cabin John Creek, and connecting to the existing park trail system
2. Adding extensive new accessible walkways to and around the new Nature Center, allowing universal access to all activities, the fire rings, and the creek
3. Adding an accessible walkway from the neighborhood on the east side of the Nature Center into the park



Figure 1. Cabin John Regional Park Master Plan. The new master plan features universal access opportunities and maximizing park awareness and visibility

## Locust Grove Design Goals

- Create opportunities to embrace nature through sensory experiences
- Design with a sensitivity toward conservation and sustainability
- Maximize educational opportunities
- Consider ways to engage the public, volunteers, and sponsors
- Support programming for all ages and abilities
- Design spaces that are flexible and multifunctional
- Design for nature centered recreation

## Potential Logos for Locust Grove Nature Center





# Master Plan

## Cabin John Park Amenities

The greater Cabin John Regional Park has much to offer the residents of Montgomery County. There are extensive recreational activities as well as hiking and biking trails.

Facilities at the park include:

- baseball fields
- tennis courts
- indoor ice skating rink
- camp grounds
- picnic areas
- playgrounds
- the unique opportunity to relax and cool off on a hot summer day riding the very popular two-mile miniature train through the shady woodland.

Accessible by trail from the Nature Center are a number of ecological and educational amenities. The creek is a favorite destination for children who come to wade and have a nature class. The meadows, managed grasslands, forests, and flood plains allow a wide range of educational opportunities around the park.



Figure 2. Playing in the creek  
([www.theparkerfamily.org](http://www.theparkerfamily.org))



Figure 3. Existing Locust Grove Nature Center  
([www.montgomeryparks.com](http://www.montgomeryparks.com))



Figure 4. Cabin John baseball fields  
([www.montgomeryparks.com](http://www.montgomeryparks.com))



Figure 5. Cabin John Creek  
M. Rausch 2017



Figure 6. Locust Grove fire pit  
P. Parker 2017



Figure 7. Cabin John miniature train  
([www.montgomeryparks.com](http://www.montgomeryparks.com))

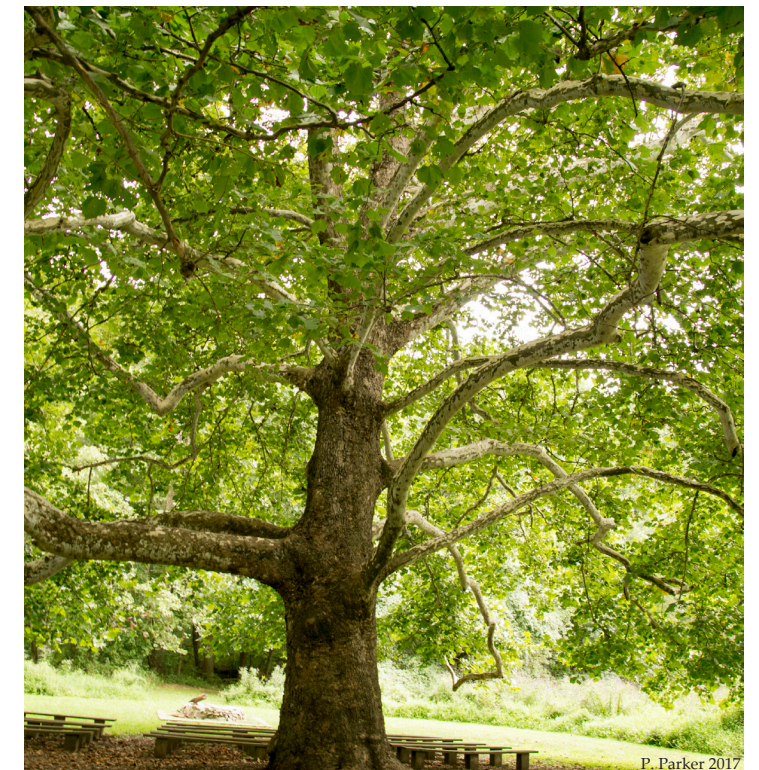


Figure 8. Grand Daddy Sycamore - a beloved landmark  
P. Parker 2017

# Master Plan

## Accessibility

### Existing Trails

The existing Nature Center trails allow pedestrians to travel between Democracy Boulevard and Westlake Drive.

- The trails near Democracy Boulevard connect the parking lot and the Nature Center building, with additional trails leading to Cabin John Creek.
- A small parking lot off Westlake Drive allows access into Cabin John Regional Park to the north and the Nature Center to the south.
- An extensive trail system within the park allows hikers and bikers to traverse the entire Cabin John Park.

### Proposed Neighborhood Connection

Locust Grove Nature Center is surrounded by residential, entertainment, and commercial areas. New walkways would give access to neighbors from adjacent communities. These walkways will allow pedestrians from the shopping areas and the bus stop to visit the center.

A major new trail is proposed to connect the Inverness Forest neighborhood, a subdivision located northwest of the park, to the greater park across a proposed bridge.

### Proposed Bridges over Cabin John Creek

The first of two proposed bridges over the Cabin John Creek would be essential to connect the neighborhoods on the west to the park. A second bridge could be built north of the Tennis Center to allow a more primitive trail, with steeper running slopes, to carry pedestrians along the creek's west side to cross over to Democracy Boulevard.

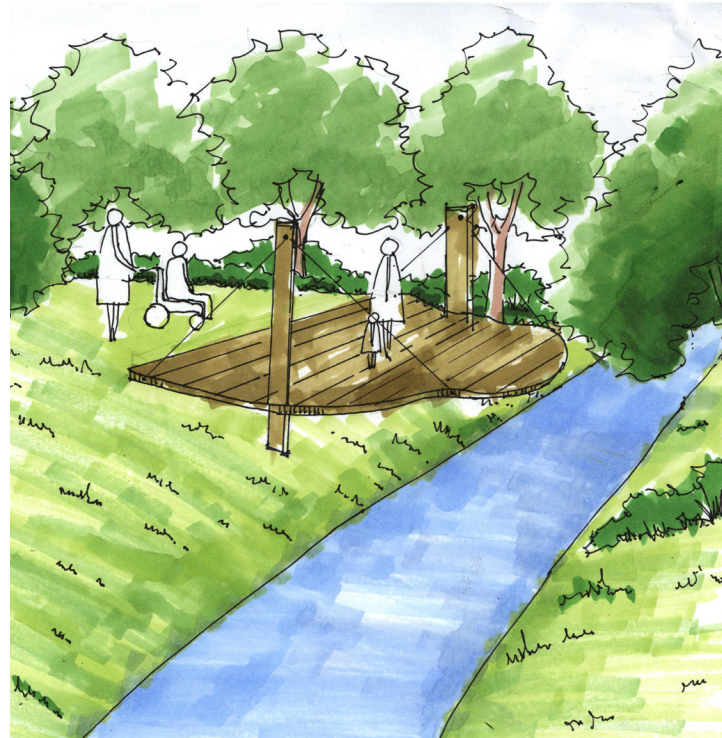


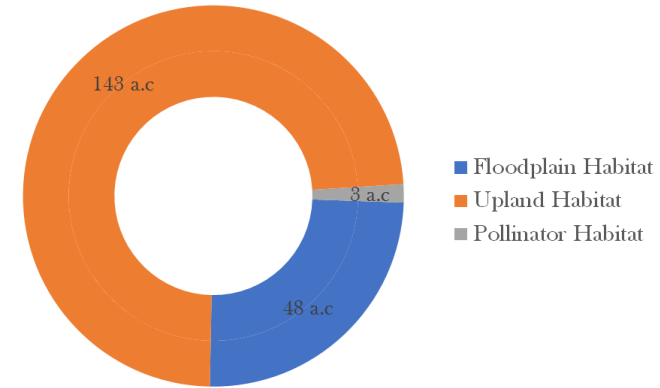
Figure 9. Proposed easy access and overlook deck at creekside



Figure 10. Proposed trail head

## Performance Metrics

### Habitats



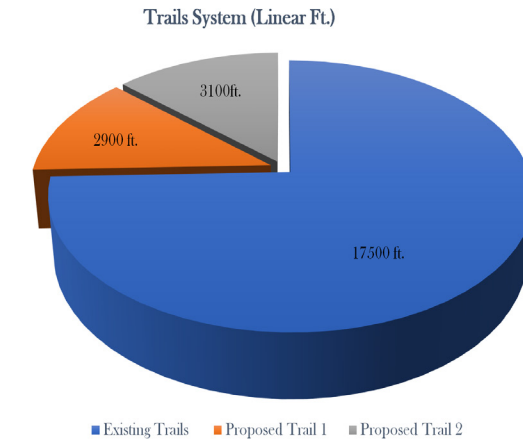
The Locust Grove Nature Center includes three habitats: upland habitat, floodplain habitat, and pollinator habitat.

- The upland habitat is 143 acres and comprises most of the nature center.
- The floodplain habitat is 48 acres near the wet meadow.
- The pollinator habitat is 3 acres.



Figure 11. Proposed accessible bridge across the creek

### Trails



The Master Plan for the proposed trail system in the greater Cabin John Regional Park will add approximately 6,000 linear feet of new trail. The new trail is composed of two parts:

- Trail 1, originating near the Inverness Recreation Center, totals 2,900 linear feet and will be designed to have a firm and stable surface at a gentle slope less than 8.3%. This will be used as the connection between Locust Grove Nature Center and the adjacent neighborhoods
- Trail 2, branching off of Trail 1 before the proposed bridge over the creek, will be a primitive, steep trail along the west side of Cabin John Creek ending at another bridge near the tennis center and Democracy Boulevard. This primitive trail is 3,100 linear feet
- Existing trails in the nature center are approximately 17,500 linear feet.

The trail connections to adjacent neighborhoods will connect to approximately 600 housing units, along with apartments and some commercial uses. This new trail offers a convenient access to the Nature Center for the adjacent neighborhoods.

### Focus on Locust Grove

The following pages detail three design concepts for the new Nature Center. Each concept strives to create a place for all ages and abilities to visit, learn, and play.

## Design Concept

This site plan for Locust Grove Nature Center aims to maximize connections with the outdoors and the various habitats available in the park to engage all visitors with nature. The new nature center sits on a natural bluff overlooking Democracy Boulevard and is visible from that road. A large nature play space is next to the Nature Center with easy access from the classrooms inside. The Center also features exhibit space, a rentable multipurpose room, staff offices, and a large deck that can host events as well.

The existing Nature Center building will be repurposed as a nature preschool. A small nature play space is next to the preschool and feature a fire pit available for events. This second nature play space ensures that children of all ages will be accommodated and able to play in a natural setting.

Other parts of the site are reached via a paved, accessible trail that passes the two nature play spaces, nature preschool, amphitheater, restored wetland meadow, and Grand Daddy Sycamore. Views are enhanced when exploring the canopy walk which extends from the new nature center out into the forest and reaches heights of over 40 feet. This feature allows visitors to be immersed in the forest and also provides several platforms for education, interpretation, or other gatherings.

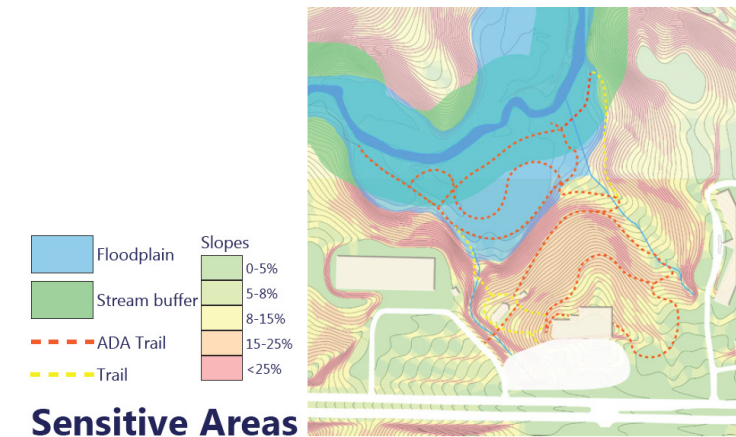
Educational opportunities throughout the site are maximized with interpretive signs and outdoor classroom spaces in the upper and lower meadows. These meadows also serve as habitat for pollinators, birds, and other wetland species. The outdoor classrooms are available for use by nature center programs, the nature preschool, visiting school groups, and all visitors.

Many areas of the Nature Center site are available for evenings use as well. The four campfire sites at the amphitheater, nature preschool, creek, and Grand Daddy Sycamore can be rented. The flexible spaces of various sizes in the Center building are available for events and can connect to the expansive deck as well.

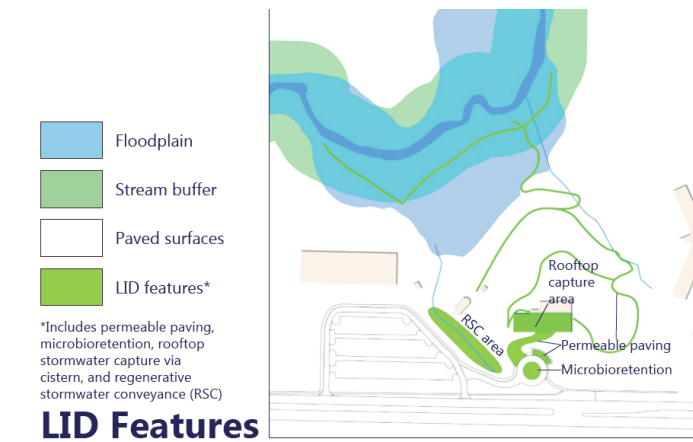


Figure 1. Locust Grove Site Plan Concept 1

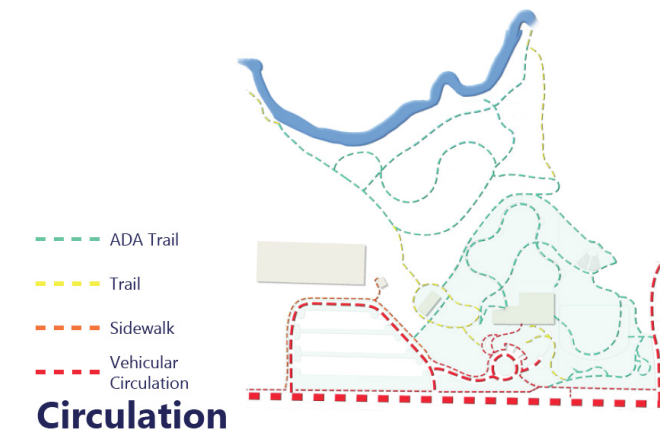
## Diagrams



Sensitive areas were considered when planning trail and building locations and avoided whenever possible. Sensitive areas include the 100-year floodplain, a 150-foot stream buffer, and steep slopes. Slopes over 25% were avoided entirely while those between 15% and 25% were tread on lightly.



The Nature Center site plan includes several Low Impact Development (LID) features focused on stormwater management. The proximity to the stream and floodplain makes it crucial to capture as much stormwater as possible close to its source. The runoff from Democracy Boulevard that goes into the creek is managed by a regenerative stormwater conveyance (RSC) system, which slows rushing water and captures sediment and pollutants in a series of pools. The center of the new turnaround forms a microbioretention area. Permeable paving is used on the entry walk, accessible parking, and accessible trails. Stormwater from the roof of the new nature center is captured and directed to treatment as well.



Circulation within and around the Nature Center is depicted in the diagram above. Vehicular circulation to the new Center is enhanced by a turn-around that connects via the existing parking lots.

## Inspirations



**Figure 2. Nature Center Building Precedent**  
The Environmental Nature Center in Newport Beach, CA (encenter.org)



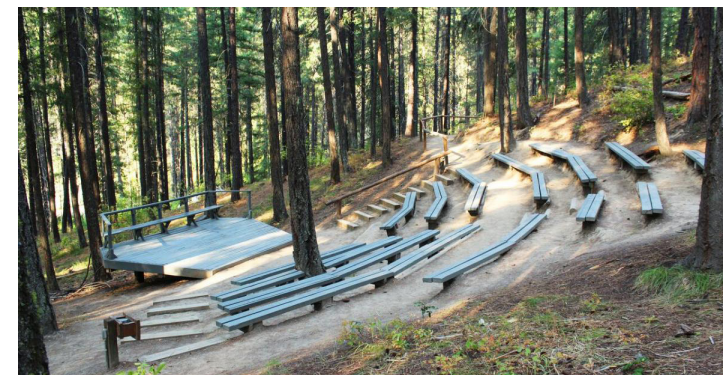
**Figure 3. Nature Play Space**  
A nature play space with logs and stones for climbing and balance (play-scapes.com)

## Performance Metrics

### Trails Added



### Spaces Added



**Figure 4. Forest Amphitheater**  
An amphitheater in the forest with stage and benches in the hillside (tierraretreat.com)



**Figure 5. Canopy Walk**  
Canopy walk at the Atlanta Botanical Gardens (flickr.com/people/12017190@N06)

# Discovering Connections through Nature

Design Team:  
Carey Evans + Katie Ferguson

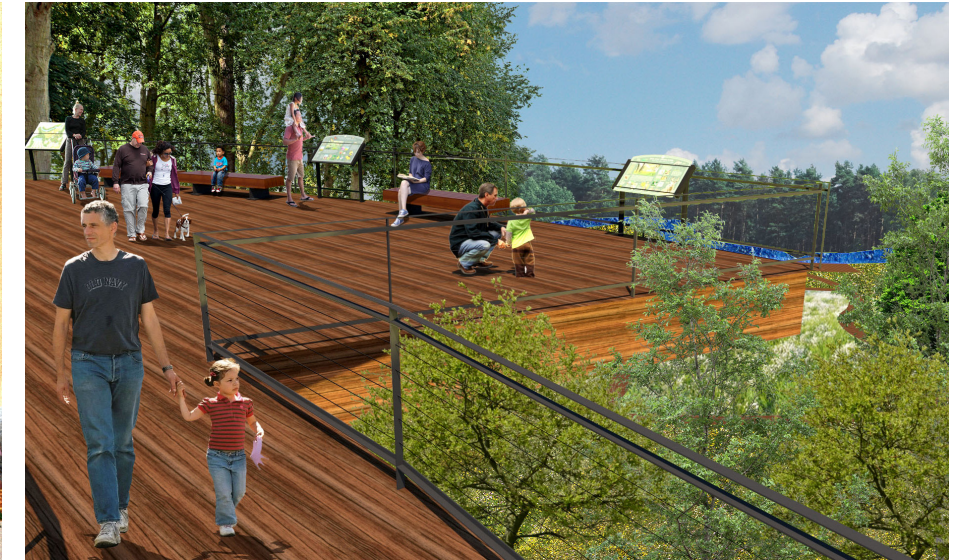
## Perspective Images



**Figure 6. Nature Play Space**  
Children in the large new nature play space next to the Locust Grove Nature Center, visible in the background with the canopy walk.



**Figure 7. Entrance Walk**  
The entry to the new Locust Grove Nature Center is fully accessible and features an iconic sign with the new logo.



**Figure 8. Canopy Walk Deck**  
The large deck at the end of the canopy walk affords views of the treetops, wetland meadow, and the stream below.



**Figure 9. Creek Restoration Perspective**  
This creekside classroom allows visitors to get close to and learn about the stream after a walk through the wetland meadow.



**Figure 10. Amphitheater Fire Ring**  
The forest amphitheater doubles as a fire ring for nighttime gatherings and entertainment.

MASTER PLAN + SITE DESIGNS: Discovering Connections through Nature

# Nature's Embrace

Design Team:  
Lotoia Simpson + Sebastian Velez-Lopez + Keren Zhang

## Design Description

This design concept strives to create a unique destination within the Montgomery County Parks system that offers extensive opportunities for visitors to embrace nature through sensory experiences. Opportunities are maximized by designing all the outdoor spaces to allow for direct contact with nature, even the intensively constructed area around the new nature center. To do this the building was placed to provide a natural buffer between it and the street, but close enough to the street to take advantage of the frontage. Cladding almost all sides of the building with glass also allows visitors to maintain visual contact with nature from almost anywhere inside.

The site also offers a diverse set of experiences through which visitors of all ages and abilities can embrace nature, including the opportunity to observe the forest canopy up close as they walk along the ADA accessible Canopy Walk. The Canopy Walk includes additional opportunities for nature centered recreation and education through the Spider Web Play area and exhibit, the canopy overlook, and the bird exhibit. Other options to embrace nature include: taking in the views from the Nature Center deck; learning about the edible native plant species as they sample from the edible forest garden; climbing, jumping, painting, or building in the nature play spaces; learning about pollinator habitat and species as they walk along the meadow boardwalk; enjoying a performance or listening to a lecture in the forest amphitheater; and enjoying a moment alone or with others in one of the many gathering and seating spaces throughout the site. The flexibility and multi-functionality of all these spaces also multiplies the opportunities for all stakeholders to engage with the site.

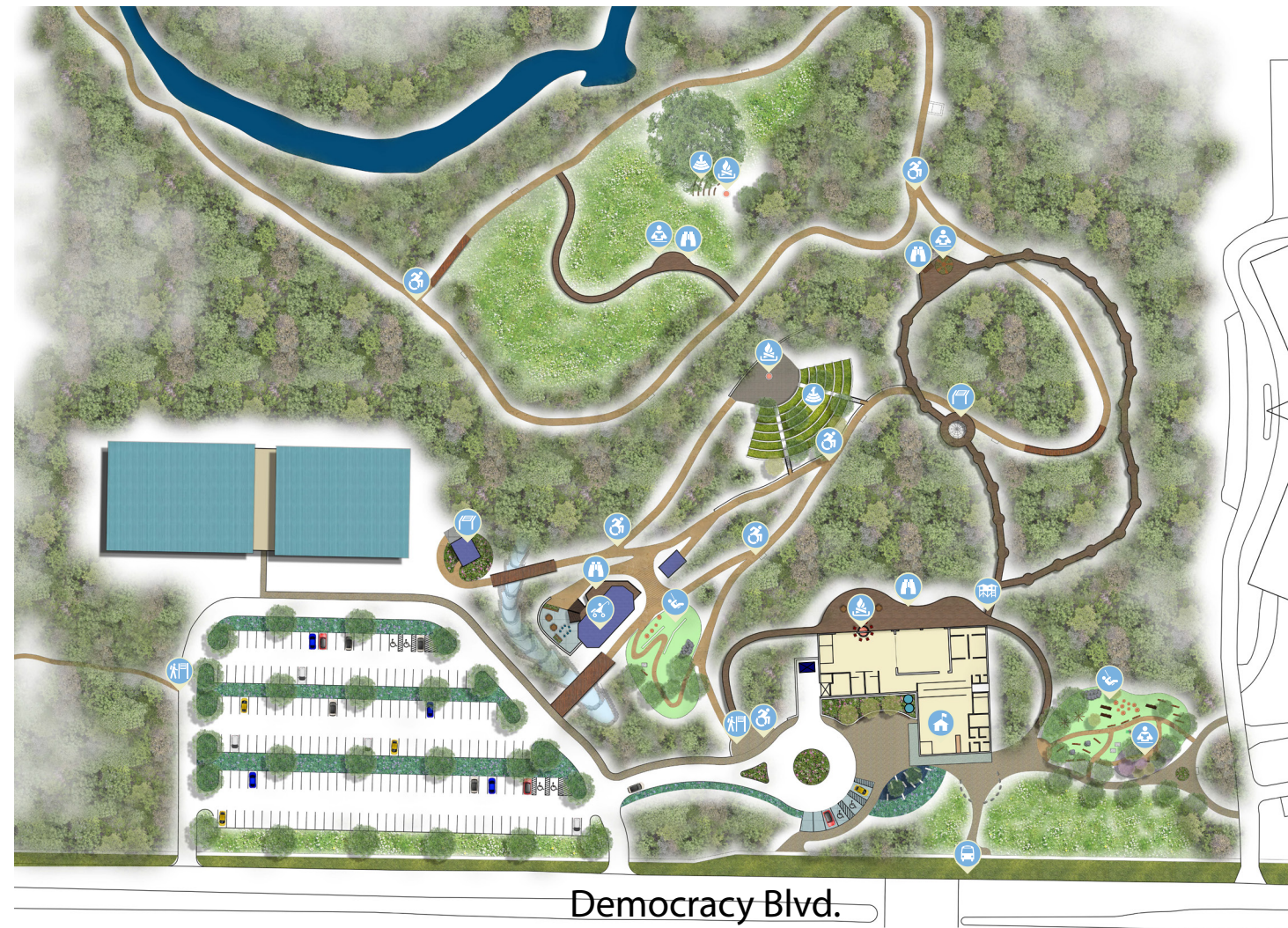
Flexibility of space was also considered when designing the floor plan of the 18,000-square foot building, which holds a 3,000-square foot multi-purpose room and a 2,800-square foot exhibit space. The wall between them and all of the windows are retractable, so that they can be combined along with the deck to create a large event space fit for weddings or graduation parties.

Accessibility is guaranteed for all of these spaces by a network of ADA compliant paths, trails, and ramps throughout the site. These also help to engage the public by allowing local residents to easily access the site, and providing connectivity between its surroundings.

For example the paths in the front pollinator meadow provide an efficient yet pleasant link between Lake-side Terrace Condominiums, the Nature Center, and the bus stop. The addition of a third parking bay, a drop-off loop with accessibility parking, and a service entrance also increase vehicular accessibility for both visitors and employees alike.

It is also important that the design is sensitive to conservation and sustainability issues, which led to the inclusion of several LID features that capture all stormwater on site, and conserve energy and potable water (see performance metrics). Conservation of cultural elements was also considered, such as re-purposing the existing Nature Center as a full-time pre-school.

## Site Plan



## Diagrams



Figure 1. Habitat & LID Features

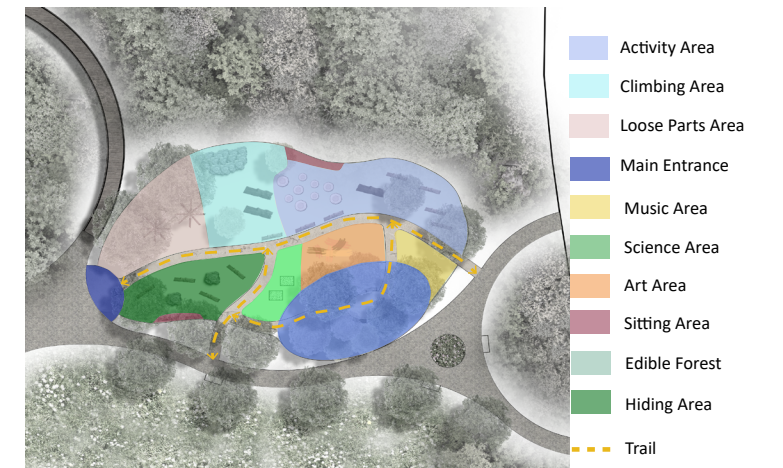
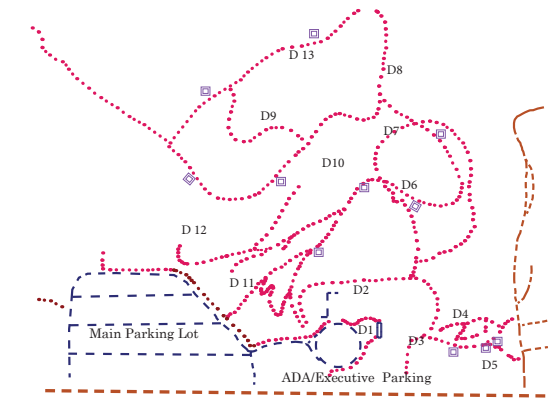


Figure 2. Nature Play Space



- |                               |           |                          |
|-------------------------------|-----------|--------------------------|
| Road                          | — — — — — | Destination-D            |
| Vehicular Path                | - - - - - | D1- Welcome Plaza        |
| ADA Multi-Use Pedestrian Path | · · · · · | D2- Nature Center Deck   |
| Non-ADA Path                  | · · · · · | D3- Pollinator Exhibit   |
| Seating                       | □         | D4- Nature Play Space    |
| Bike Rack                     | □         | D5- Small Gathering Area |
|                               |           | D6- Spider Web           |
|                               |           | D7- Bird Exhibit/Yoga    |
|                               |           | D8- Reflection Area      |
|                               |           | D9- Observation Meadow   |
|                               |           | D10- Amphitheater        |
|                               |           | D11- Play School         |
|                               |           | D12- Log Cabin           |

Figure 3. Site Circulation

## Plan Legend

- |                             |                       |                      |
|-----------------------------|-----------------------|----------------------|
| Forest                      | Nature Center         | Amphitheater         |
| Wildflower Meadow           | Accessible (moving)   | Play space           |
| Flower Beds                 | Learning location     | Canopy walk          |
| Bio-infiltration            | Viewing/bird watching | Fire ring            |
| Birds Nest Exhibit          | Bus stop              | Grand Daddy Sycamore |
| Spider Web Play and Exhibit | Bridge                | Preschool            |
| Pavilion of Reflection      | Interpretive Sign     | Trail head           |

## Inspirations



Figure 4. Scott Amphitheater at Swarthmore College (tclf.org)



Figure 5. Treetop Walkway at Kew Gardens (www.kew.org)

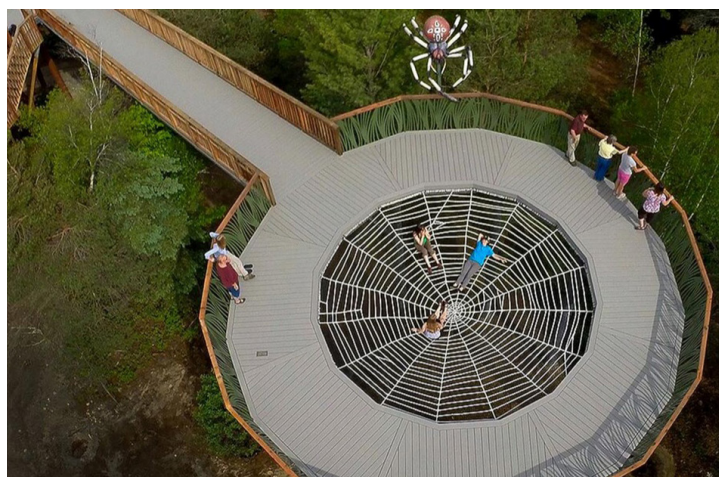


Figure 6. Spider's Web at Wildwalk, NY (6sqft.com)

## Perspective 1: Walking by on Democracy Blvd.



Figure 7. The forest out front would be removed in order to expand the pollinator meadow. Besides increasing pollinator habitat, this opened would open up the views from Democracy Blvd. toward the Nature Center.

## Inspirations



Figure 8. Slide and scramble at Royal Park, AU  
(mumsgrapevine.com.au)



Figure 9. Balancing Logs at Westmoreland Park, OR  
(www.pdxparent.com)



Pavilion at Walter Reed Green Road, MD (usupulse.blogspot.com)  
Figure 10. Pavilion at Walter Reed Green Road, MD  
(usupulse.blogspot.com)

## Perspective 2: Drop-off Plaza

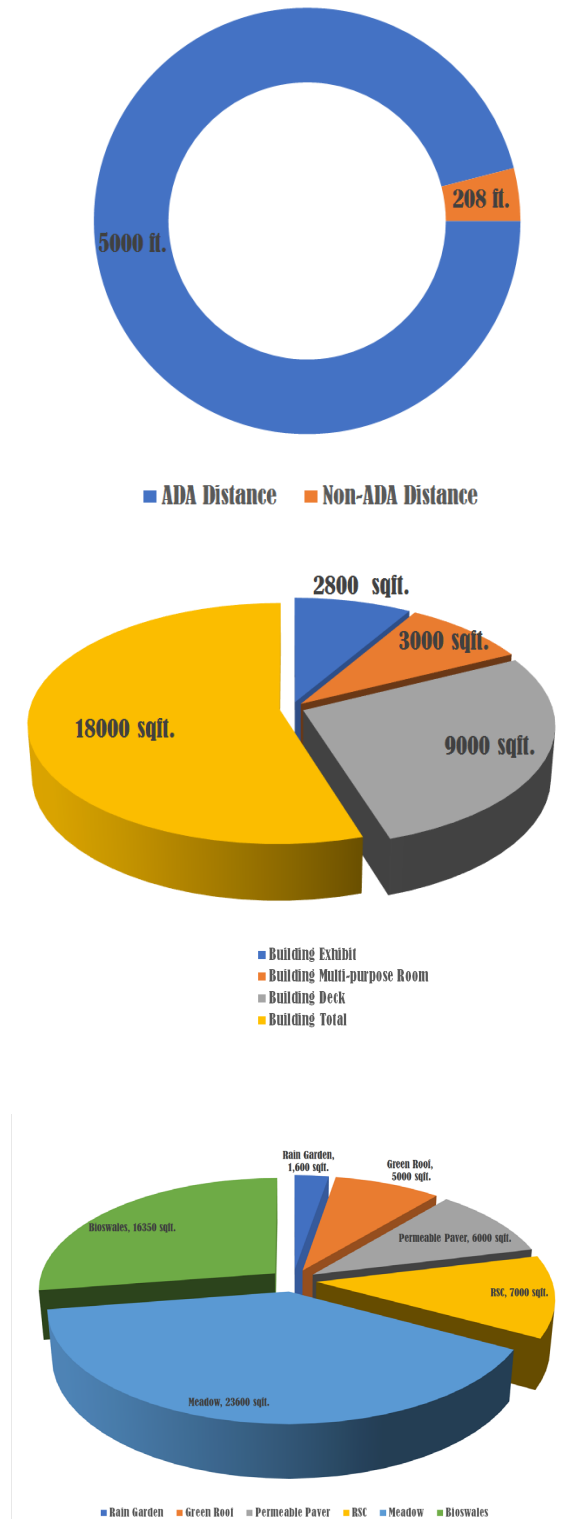


Figure 11. The drop-off plaza is one of several gathering spaces providing seating and a flexible activity space. It is spacious enough to hold small farmers markets or fairs, and its circular form creates a welcoming atmosphere for visitors. Seating areas to the right and left allow people to stay for extended periods of time.

MASTER PLAN + SITE DESIGNS: Nature's Embrace



## Performance Metrics



## Perspective 3: Canopy Overlook and Bird Exhibit



Figure 13. The canopy overlook would have a flexible activity space that could be used for anything from yoga classes to school trips. The contemporary structure of the bird exhibit (right side) would serve as a unique aesthetic feature, and an educational resource for the public. It also reinforces the bird watching opportunity provided by this unique feature.

MASTER PLAN + SITE DESIGNS: Nature's Embrace

# Nature's Embrace

Design Team:  
Lotoia Simpson + Sebastian Velez-Lopez + Keren Zhang

## Perspective 4: Nature Center Deck



Figure 14. Visitors can enjoy the peaceful views into the forest beyond.

## Perspective 6: Forest Amphitheater

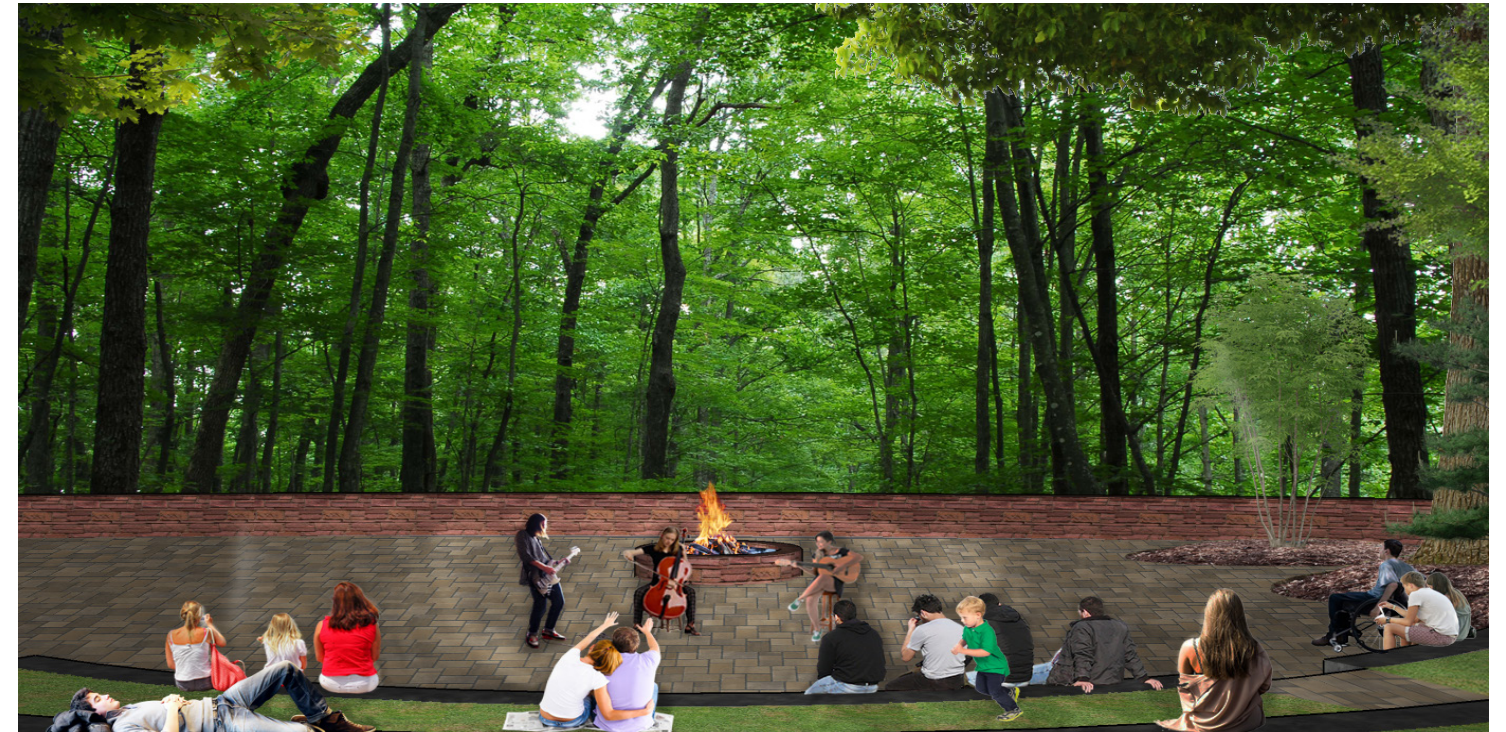


Figure 15. People of all ages and abilities can enjoy concerts and many other performances throughout the year.

## Perspective 5: Meadow Boardwalk



Figure 16. Walking along the meadow boardwalk can be a calming experience as well as an educational one.

## Perspective 7: Nature Play Space



Figure 17. Kids can run climb and jump through a variety of multi-functional play areas.

MASTER PLAN + SITE DESIGNS: Nature's Embrace

## Site Design



## Design Description

This design concept envisions bringing more people to the Locust Grove Nature Center to stir an appreciation and fondness for the natural environment and our planet. Investing in the creation and building of this new Nature Center is a gift from this generation to the many that follow.

The plan's centerpiece is an impressive, rounded, glass building with two story entrance atrium sited on a raised plateau within sight of Democracy Boulevard. This new Nature Center will house classrooms, exhibit space, and a flexible large event space that will be the talk of the town.

As inspiring and essential as this new building will be, drawing the visitors out and into nature is the true goal of this center. The design will accomplish this goal by adding and enhancing many features of the park.

- A constructed habitat pond at the entrance is designed to showcase native trees and shrubs and wildlife in the Cabin John Creek area
- Firm and stable walkways with gentle slopes throughout the Nature Center allowing visitors of all ages and abilities to travel from the parking lot, into the new building, and through the forest to the creek and to the destinations listed below
- A large deck overhanging the north slope of the new building designed with a central opening for canopy to peak through and a smaller deck beyond the trees that will be more quiet and reflective
- A new nature play space designed for the school age children with a central raised platform for playing and jumping
- Two covered picnic areas at the play space
- A new outdoor amphitheater built into the forest slope with a stage and fire ring for meetings, classes and performances
- Planted meadow pollinator habitat gardens along the road and entrance to the Nature Center
- An educational boardwalk in the lower meadow

## Inspirations



Figure 1. Meadow Walk  
([www.archdaily.com](http://www.archdaily.com))

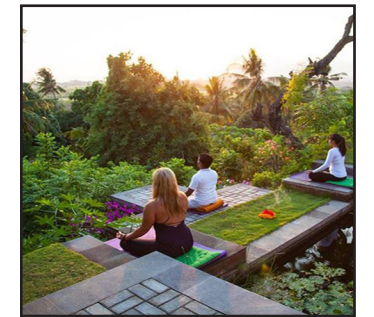


Figure 2. Outdoor Yoga  
([www.zenresortbali.com](http://www.zenresortbali.com))



Figure 3. Nature Center Entrance  
([www.lpda.net](http://www.lpda.net))



Figure 4. Gathering Space  
([planforplay.centralparknyc.org](http://planforplay.centralparknyc.org))



Figure 5. Canopy Walk  
([worldarchitecturenews.com](http://worldarchitecturenews.com))

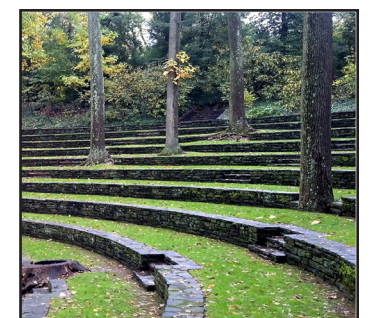


Figure 6. Natural Amphitheater  
([www.scottarboretum.org](http://www.scottarboretum.org))

## Design Focus Diagrams

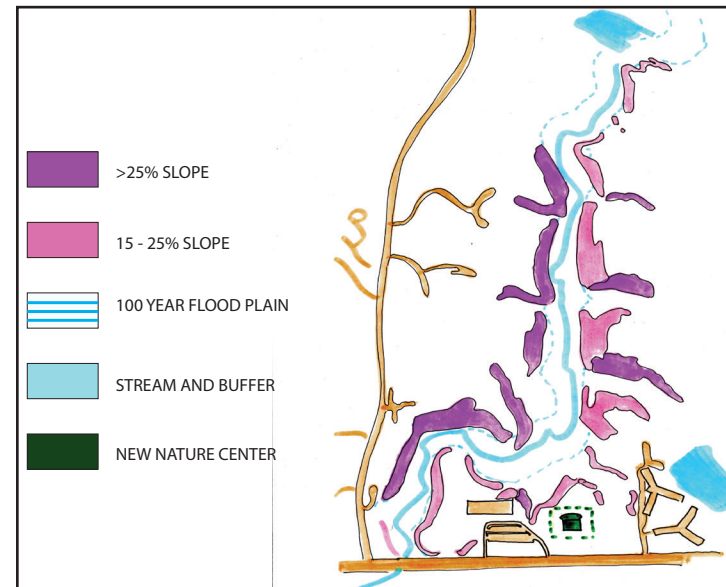


Figure 7. Sensitive Areas Avoided

Sensitive areas are protected. These areas include steep slopes, stream buffers, 100-year flood plain, wetlands, unstable soils and endangered species habitats

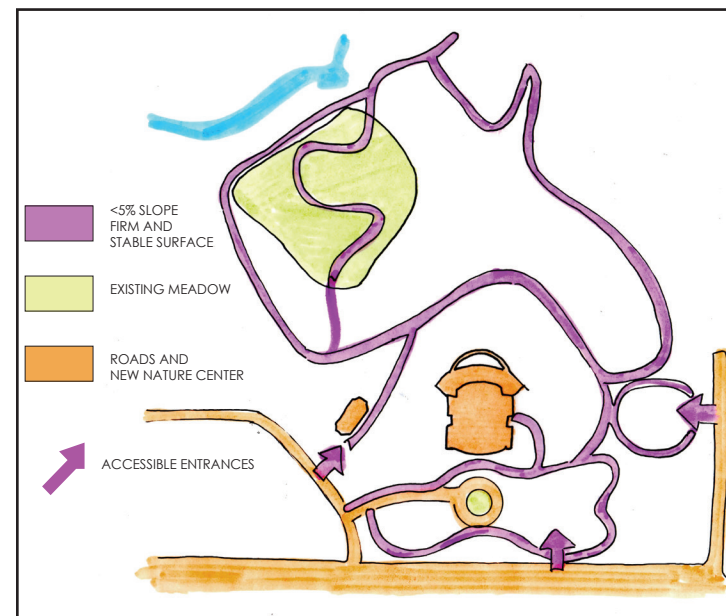


Figure 9. Accessible Paths

New firm and stable walkways that meet accessibility standards throughout the Nature Center

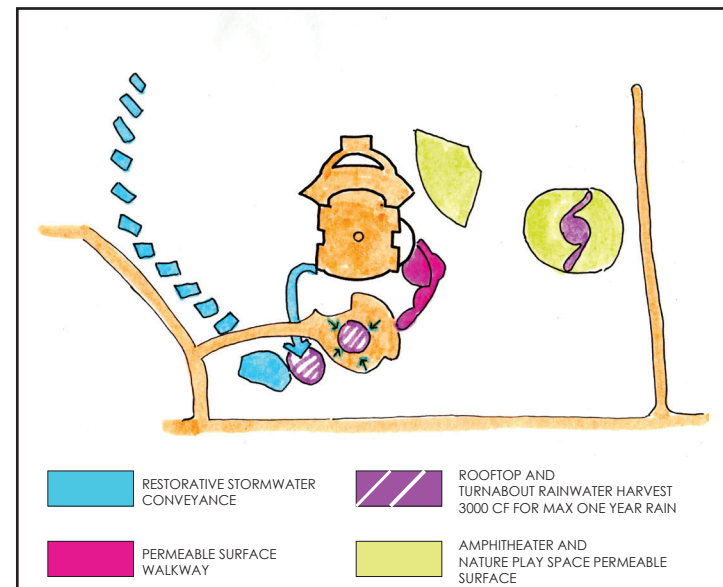


Figure 8. Storm Water Management

Stormwater capture with an aesthetic and educational component. A bioinfiltration area adjacent to the constructed habitat pond is 3000 cf., large enough to capture a one year storm event

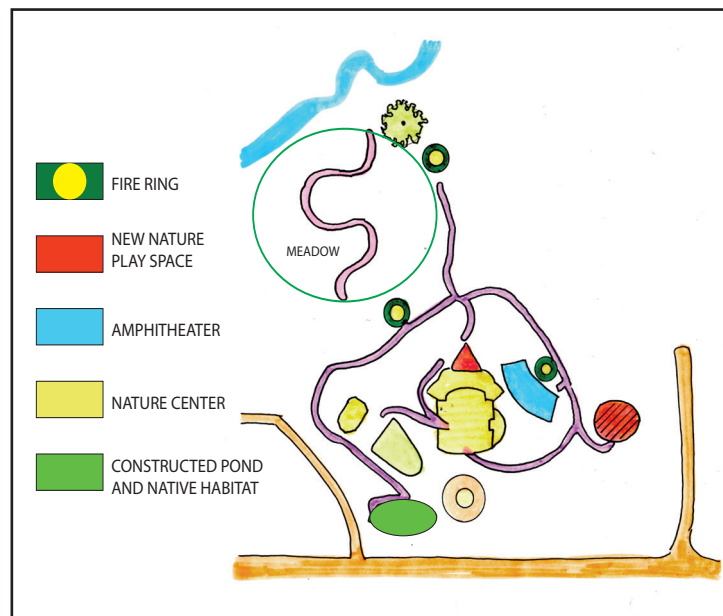


Figure 10. Circulation to Educational Sites

Accessible walkways to the educational sites in the Nature Center

## Nature Center Design Concept

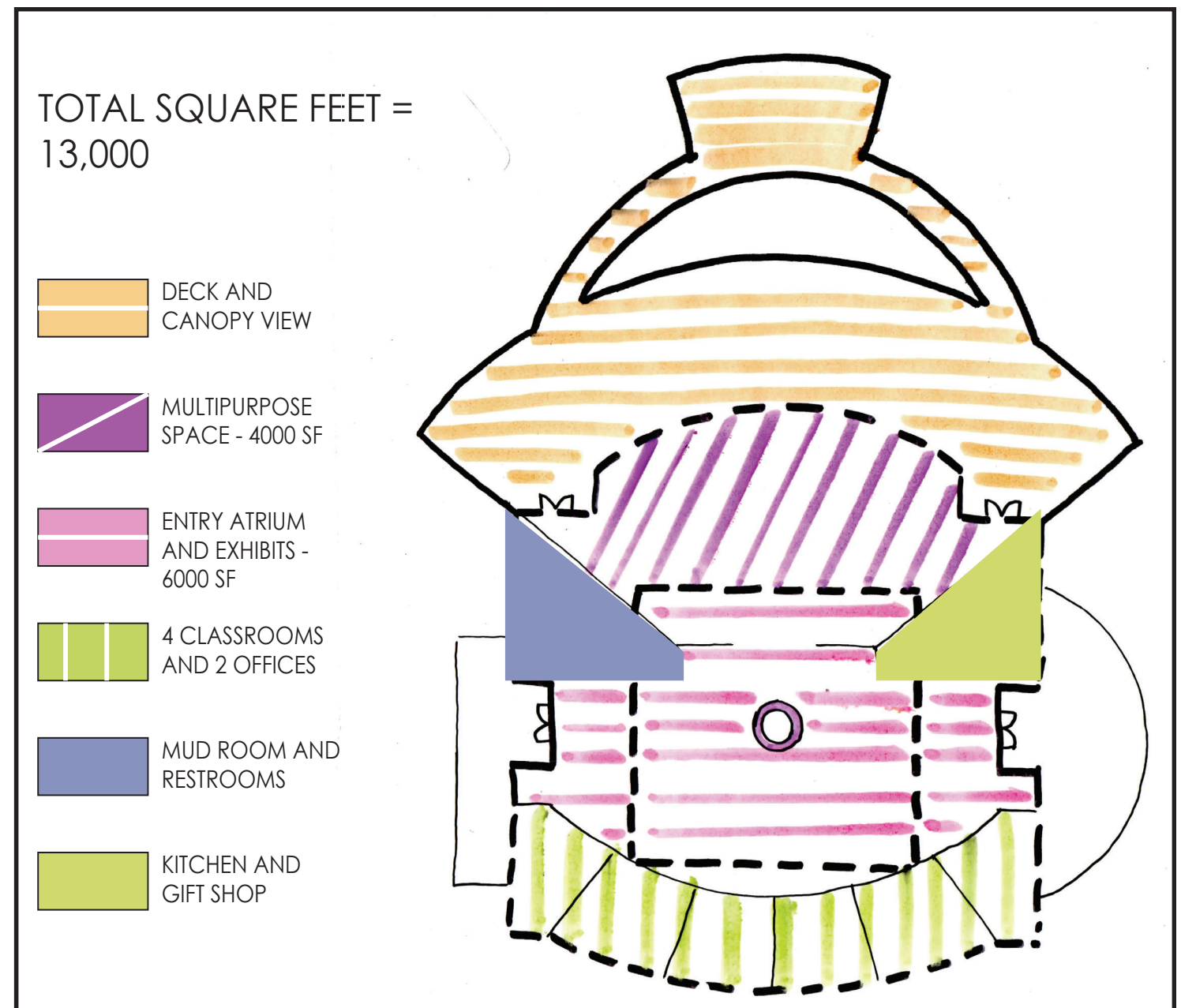


Figure 11. New Nature Center

The interior of the new Nature Center will be an open, light filled space with adequate room for exhibits that are movable and flexible as well as classrooms and offices. A large multipurpose area is included for exhibits, conferences and events. This space has glass walls and direct access to the deck as well as an adjacent kitchen. Restrooms, a mudroom for the day campers, and a gift store are shown. Additional storage could be accessed under the deck. An entrance patio and café will serve coffee and snacks to visitors.

# Bringing Nature Within Reach

Design Team:  
Pam Parker + Afrouz Rahmati + Matt Rausch



Figure 12. View from Democracy Boulevard



Figure 13. Entrance Terrace and Cafe



Figure 14. Bird's-Eye View from the West

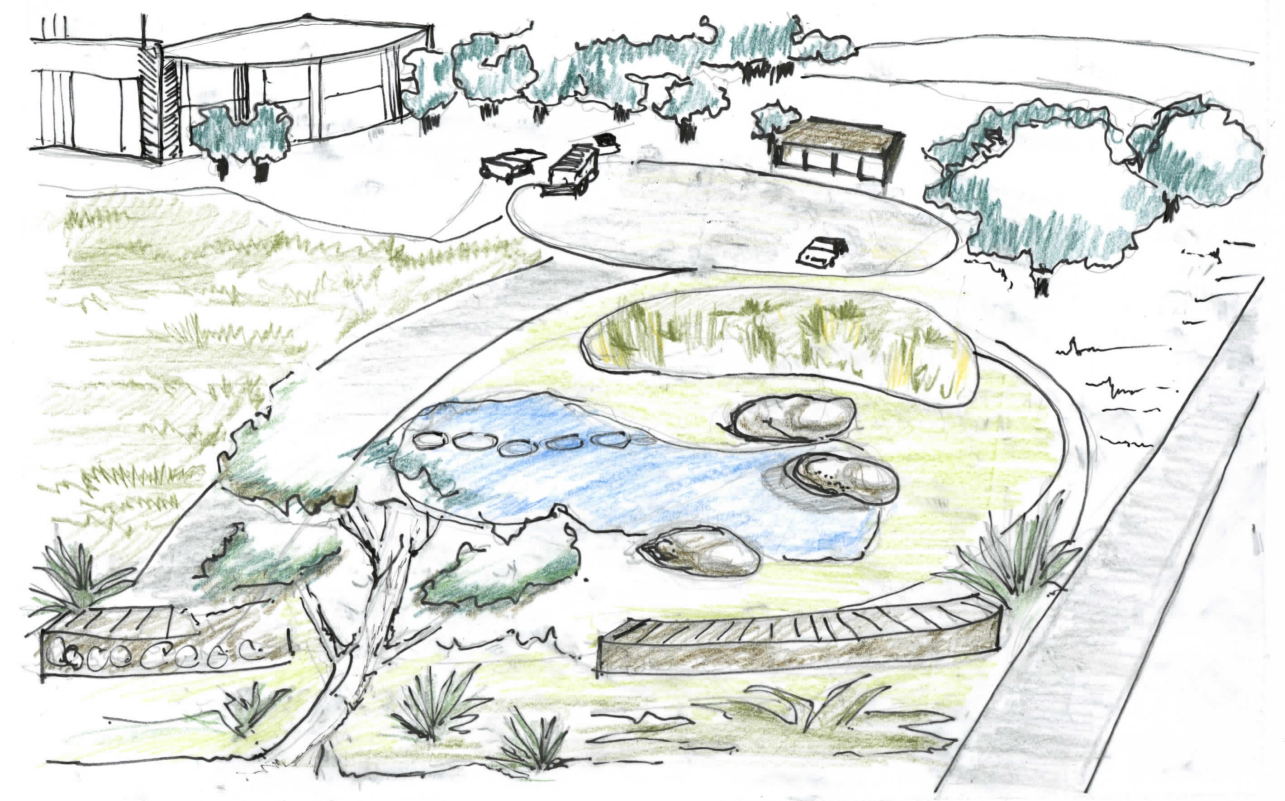


Figure 15. Bird's-Eye View from the East

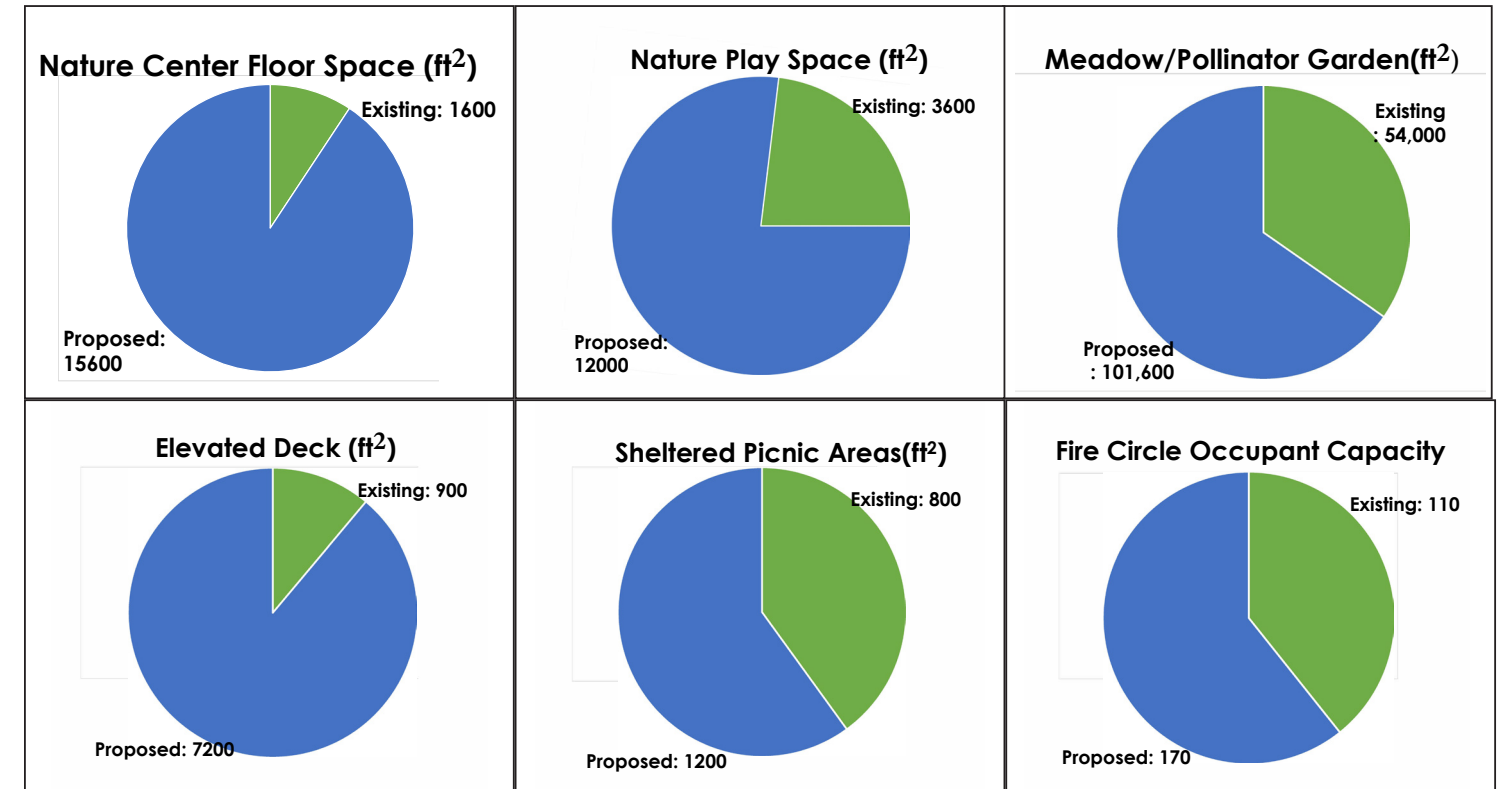


Figure 16. Natural Amphitheater



Figure 17. Deck and Canopy Walk

## Performance and Design Metrics



Sheltered Gathering Space Proposed	800 sf
Gathering: Cafe and Terrace Space Proposed	1 100 sf
Bioretention Capture Area	2960 sf
Rain Water Harvest Area	6100 sf
Permeable Paver Surface	270 sf
Designated Regional Habitats Area	3170 sf
ADA Accessible Paths	5560 ft
Non-ADA Trails	1240 ft
Meadow Habitat Boardwalk	640 ft
Natural Amphitheater and Fire Circle : Capacity	350 Ppl

MASTER PLAN + SITE DESIGNS: Bringing Nature Within Reach

# References

---

- "2010 ADA Standards for Accessible Design." [https://www.ada.gov/2010ADASTandards\\_index.htm](https://www.ada.gov/2010ADASTandards_index.htm). Referenced Dec. 7, 2017
- "ABA Standards - United States Access Board." <https://www.access-board.gov/guidelines-and-standards/buildings-and-sites/about-the-aba-standards/aba-standards>. Referenced Dec 7, 2017
- Adamson, N. L., Borders, B., Cruz, J. K., Jordan, S. F., Gill, K., Hopwood, J., . . . Vaughan, M. (2017). Pollinator Plants: Mid Atlantic Region (Publication). Retrieved December 11, 2017, from Xerces Society for Invertebrate Conservation website: <https://xerces.org/pollinator-conservation/plant-lists/pollinator-plants-mid-atlantic-region/> "Balancing Stewardship and Recreation in Montgomery County Parks," Hench, J.E.
- Chicago, AIA. (2015). Knoch Knolls Nature Center-Design Excellence Awards. Retrieved from [https://www.aiachicago.org/dea\\_archive/2015/knoch-knolls-nature-center/](https://www.aiachicago.org/dea_archive/2015/knoch-knolls-nature-center/)
- Department of Agriculture Forest Service, Missoula Technology and Development Center. (<http://www.fs.fed.us/t-d/bridges/> Username: t-d, Password: t-d)
- Edwards, J., Jr. (1967). Generalized Geologic Map of Maryland. Maryland Geological Survey.
- Environmental Nature Center. (n.d.). Environmental Nature Center | Providing quality education through hands-on experience with nature. Retrieved November 28, 2017, from <http://encenter.org/>
- Eriksson, Merv. 2000. Trail bridge catalog. Web site. 0023-2W01- MTDC. Missoula, MT: U.S.
- Gibson, David. (2009). The Wayfinding Handbook: Information Design for Public Places. New York, NY: Princeton Architectural Press.
- Greenroofs.com. (n.d.). Greenroofs101: Components. Retrieved November 28, 2017, from <http://www.greenroofs.com/Greenroofs101/components.htm>
- Groenier, James Scott; LeBow, Stan. 2006. Preservative-treated wood and alternative products in the Forest Service. Tech. Rep. 0677-2809- MTDC. Missoula, MT: U.S. Department of Agriculture Forest Service, Missoula Technology and Development Center. 44 p. (<http://www.fs.fed.us/t-d/pubs/htmlpubs/htm06772809/> Username: t-d, Password: t-d)
- Hopper, L., & Smith Maran Architects. (2007). Landscape architectural graphic standards (Wiley graphic standards). Hoboken, N.J.: John Wiley & Sons
- Hord Coplan Macht. (n.d.). Robinson Nature Center, LEED Platinum. Retrieved December 11, 2017, from [http://www.hcm2.com/project/robinson-nature-center\\_landscape/](http://www.hcm2.com/project/robinson-nature-center_landscape/)International Mountain Bicycling Association. 2004. Trail solutions: IMBA's guide to building sweet singletrack. ISBN: 0-9755023-0-1. Boulder, CO: International Mountain Bicycling Association. p. 272.
- Howard County. (n.d.). Robinson Nature Center. Retrieved December 11, 2017, from <https://www.howardcountymd.gov/Robinson>
- Howard County Recreation and Parks. (2017). James & Anne Robinson Nature Center: 2017 Fall Programming [Brochure]. Columbia, MD: Author.
- Howard County Recreation and Parks. (2017). James & Anne Robinson Nature Center: Facilities & Features [Brochure]. Columbia, MD: Author.
- Howard County Recreation and Parks. (2017). James & Anne Robinson Nature Center: Scout Programming [Brochure]. Columbia, MD: Author.
- John Hoke-Anthony Lewandowski-Charles Ramsey-Harold Sleeper - Wiley - 1991. Architectural graphic standards, eighth edition
- LS Black Constructors (n.d.) Eastman Nature Center Project. Retrieved September 10 2017, from <https://lsblack.com/project-post/eastman-nature-center/>
- Mannheim, (c) Michael Probst Stuckmann netconstructions de. (n.d.). Construction • Information on Green Roofs • IGRA [Text]. Retrieved November 28, 2017, from [http://www.igra-world.com/engineering/construction\\_engineering.php](http://www.igra-world.com/engineering/construction_engineering.php)
- Maryland Department of Natural Resources (n.d.) Nature Play Spaces. Retrieved September 12 2017, from <http://dnr.maryland.gov/cin/Pages/NPS/index.aspx>
- Maryland Geological Survey. (2017). Maryland Geology. Retrieved November 28, 2017, from <http://www.mgs.md.gov/geology/index.html>
- Maryland Wildlife Diversity Conservation Plan: Chapter 4
- Maryland's Key Wildlife Habitats, 2015-2015 Maryland State Wildlife Action Plan
- Minnesota Historical Society (n.d.) Hennepin County: Three Rivers Park District. Retrieved September 5 2017, from <http://www2.mnhs.org/library>
- Montgomery County Data | Open Data Portal. (n.d.). Retrieved December 11, 2017, from <https://data.montgomerycountymd.gov/>

# References

---

- Montgomery County Department of Environmental Protection (n.d.) Stream Wildlife. Retrieved October 16 2017, from <http://www.montgomerycountymd.gov/water>
- Montgomery County GIS Open Data (n.d.) Retrieved October 23 2017, from <http://data-mcgov-gis.opendata.arcgis.com>
- Montgomery County Zoning Ordinance, Division 59-E-2. Plans and Design Standards 59-E-2.22. Size of spaces.(b)
- MSR Design (n.d.) MSR Eastman Nature Center Project. Retrieved September 10 2017, from <https://msrdesign.com/project/eastman-nature-center/>
- Naperville Parks District. (n.d). [Naperville Parks Quest- Nature Scavenger Hunt) Retrieved from <https://naturescavengerhunt.oncell.com/en/index.html>
- National Recreation and Parks Association (Sep 2014) New National Guidelines for Nature Play Areas. Retrieved September 14 2017, from <http://www.nrpa.org/parks-recreation-magazine/2014/september/new-national-guidelines-for-nature-play-areas>
- National Wildlife Federation (n.d.) Connecting Kids and Nature. Retrieved 12nSep 2017, from <https://www.nwf.org/outdoors>
- Natural Resources Management Plan for Natural Areas in M-NCPPC Parkland in Montgomery County, Maryland February 2013
- Philadelphia Water. (2015). 4.5 - Cisterns. In Philadelphia Water Stormwater Management Guidance Manual. Philadelphia Water.
- Philadelphia Water. (2015, July). Stormwater Management Guidance Manual. In Chapter 4.1 Bioretention. Retrieved from [https://www.pwdplanreview.org/upload/manual\\_pdfs/PWD-SMGM-v3-20150701.pdf](https://www.pwdplanreview.org/upload/manual_pdfs/PWD-SMGM-v3-20150701.pdf)
- Reger, J. P., & Cleaves, E. T. (2008). Physiographic Map of Maryland. Maryland Department of Natural Resources: Maryland Geological Survey.
- Richard C. (2009, January 25). Cabin John as it looked in 1912. Retrieved from <http://glenecho-cabinjohn.com/CJ-02.html>
- Simmons, M. T., Gardiner, B., Windhager, S., & Tinsley, J. (2008). Green roofs are not created equal: the hydrologic and thermal performance of six different extensive green roofs and reflective and non-reflective roofs in a sub-tropical climate. *Urban Ecosystems*, 11(4), 339–348. <https://doi.org/10.1007/s11252-008-0069-4>[http://chesapeakestormwater.net/wpcontent/uploads/downloads/2014/03/VA\\_BMP\\_Spec\\_No\\_9\\_BIORETENTION\\_FINAL\\_Draft\\_v2-0\\_06Nov2013.pdf](http://chesapeakestormwater.net/wpcontent/uploads/downloads/2014/03/VA_BMP_Spec_No_9_BIORETENTION_FINAL_Draft_v2-0_06Nov2013.pdf)
- Taylor, B. L. (2008). The Stormwater Control Potential of Green Roofs in Seattle (pp. 1–10). American Society of Civil Engineers. [https://doi.org/10.1061/41009\(333\)11](https://doi.org/10.1061/41009(333)11)
- Texas Water Development Board. (2005). The Texas Manual on Rainwater Harvesting (Third). Austin, TX.
- Three Rives Park District (n.d.) Eastman Nature Center. Retrieved September 5 2017, from <https://www.threeriversparks.org/>
- United States, Access Board. (May 2014). A Summary of Accessibility Standards for Outdoor Developed Areas (pp.26). (<https://www.access-board.gov/attachments/article/1637/outdoor-guide.pdf>)
- United States Department of Agriculture, “Applying the Forest Service Outdoor Recreation Accessibility Guidelines”
- United States, USDA, NRCS. (2011). Pollinator Habitat: PA Conservation Reserve Program Job Sheet (CP42) (pp. 1-3). PA: USDA.
- Urban Design Tools. (2007). LID Urban Design Tools - Rain Barrels & Cisterns. Retrieved November 28, 2017, from [http://www.lid-stormwater.net/raincist\\_specs.htm](http://www.lid-stormwater.net/raincist_specs.htm)
- USDA. (n.d.). Web Soil Survey. Retrieved December 11, 2017, from <https://websoilsurvey.sc.egov.usda.gov/App/WebSoilSurvey.aspx>
- U.S Department of Agriculture Forest Service. (July 2007). Trail Construction and Maintenance Notebook (pp. 101-110). Missoula, MT: Missoula Technology and Development Center.
- VA DEQ. (2013, January 1). Bioretention. Retrieved from [http://chesapeakestormwater.net/wpcontent/uploads/downloads/2014/03/VA\\_BMP\\_Spec\\_No\\_9\\_BIORETENTION\\_FINAL\\_Draft\\_v2-0\\_06Nov2013.pdf](http://chesapeakestormwater.net/wpcontent/uploads/downloads/2014/03/VA_BMP_Spec_No_9_BIORETENTION_FINAL_Draft_v2-0_06Nov2013.pdf)
- VA DEQ. (2013, January 1). Permeable Pavement. Retrieved from <http://chesapeakestormwater.net/wp-content/uploads/downloads/2014/04/VA-BMP-Spec-No-7-PERMEABLE-PAVEMENT-FINAL-DRAFT-EDITS-v2-002April2014.pdf>
- Wilson, Marie. Daily Herald. (2013, July 15). Naperville’s Knoch Knolls gets eco-friendly upgrade. Retrieved from <http://www.dailyherald.com/article/20130715/news/707159934/>
- Xerces Society. (n.d.). Pollinator Conservation. Retrieved December 11, 2017, from <https://xerces.org/pollinator-conservation/>