



Butler University  
Digital Commons @ Butler University

---

Scholarship and Professional Work – COPHS

College of Pharmacy & Health Sciences

---

Summer 1997

## Pharmacology of Antiparkinsonian Agents

Robert P. Soltis

Butler University, [rsoltis@butler.edu](mailto:rsoltis@butler.edu)

Follow this and additional works at: [https://digitalcommons.butler.edu/cophs\\_papers](https://digitalcommons.butler.edu/cophs_papers)

 Part of the [Pharmacy and Pharmaceutical Sciences Commons](#)

---

### Recommended Citation

Soltis, Robert P., "Pharmacology of Antiparkinsonian Agents" (1997). *Scholarship and Professional Work – COPHS*. 251.

[https://digitalcommons.butler.edu/cophs\\_papers/251](https://digitalcommons.butler.edu/cophs_papers/251)

This Article is brought to you for free and open access by the College of Pharmacy & Health Sciences at Digital Commons @ Butler University. It has been accepted for inclusion in Scholarship and Professional Work – COPHS by an authorized administrator of Digital Commons @ Butler University. For more information, please contact [digitalscholarship@butler.edu](mailto:digitalscholarship@butler.edu).

# Pharmacology of Antiparkinsonian Agents

Robert P. Soltis<sup>1</sup>

College of Pharmacy and Health Sciences, Drake University, Des Moines IA 50311

## PROLOGUE

The following is a summary of a two hour class on the basic pharmacology of antiparkinsonian agents. It is presented to fourth-year pharmacy students in pharmacotherapeutics III, a course structured using team-taught modules. Faculty from the Department of Pharmacy Sciences provide instruction on the basic pharmacology of therapeutic agents and faculty from the Department of Pharmacy Practice follow up with a discussion of the therapeutic applications of these agents. This course is lecture-based with opportunities for in-class discussion.

One week prior to the lecture sequence on the basic pharmacology of antiparkinsonian drugs, students are provided a handout that includes the reading assignment (1), learning objectives and a topic outline. The topic outline contains the chemical structures of the agents to be discussed as well as the figures, patient scenarios and study questions appearing in this manuscript. During each 50-minute period, material is presented as a lecture tied to patient scenarios. The scenarios are presented in class immediately after covering the pharmacological concepts to which they apply. Students are asked to discuss in small groups potential solutions to the scenarios and to offer their answers to the rest of the class on a volunteer basis. The study questions are geared for preparing for exams and are not discussed in class unless students request. At the end of these two lectures, a homework problem is assigned that introduces the 6-hydroxydopamine rat model of Parkinson's disease. The following week, a live demonstration related to the homework is presented in class with a short discussion afterwards.

The objectives of these classes focus on understanding the pharmacological mechanisms of drug therapy for Parkinson's disease and using this information to predict or solve drug-related problems. Specifically, the student should be able to: (i) describe the symptoms and neuropathology associated with Parkinson's disease; (ii) discuss how current drug therapy and the different mechanisms of action are useful in the treatment of Parkinson's disease; (iii) understand how the course and the severity of the disease can affect drug therapy; and (iv) predict potential side effects and drug interactions and suggest ways to alleviate these problems based on pharmacological and pharmacokinetic concepts.

## PARKINSON'S DISEASE

Parkinson's disease is a disorder of the central nervous system that is characterized by three cardinal features: (i) bradykinesia (slowness of movement); (ii) muscular rigidity; and (iii) resting tremor that stops upon voluntary movement. Other symptoms that may occur include stooped

<sup>1</sup>Assistant professor of pharmacology.

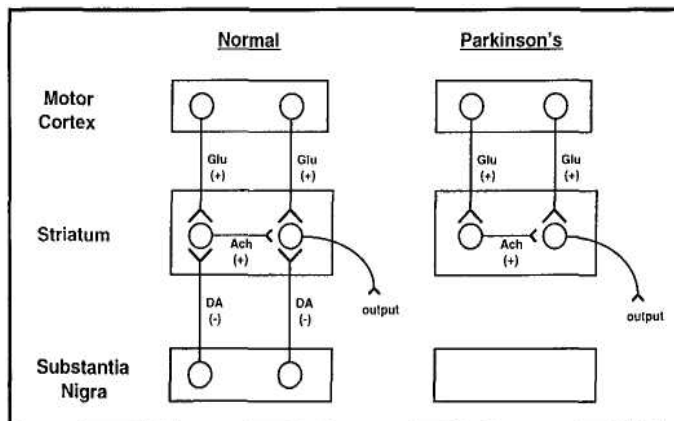

Fig. 1. Neuronal projections from the motor cortex and substantia nigra to the striatum in normal (left) and parkinsonian patients (right). Minus signs (-) represent the inhibitory actions of dopamine (DA); plus signs represent the excitatory actions of acetylcholine (ACh) and glutamate (Glu) in the striatum.

posture with a characteristic shuffling gait, sialorrhea and dementia during the later stages of the disease (2-5).

The disease is characterized by a selective loss or degeneration of the nigrostriatal pathway. This pathway consists of neurons that project from the substantia nigra to the striatum and use dopamine as the neurotransmitter (Figure 1). Acetylcholine and glutamate are also present as neurotransmitters in the striatum but are unaffected by the disease. As a consequence, there is an imbalance between the inhibitory actions of dopamine and the excitatory actions of acetylcholine and glutamate in the striatum. All of the major symptoms seen in Parkinson's disease appear to be attributed to this imbalance. Interestingly, the symptoms of Parkinson's disease do not present until 70-80 percent of the dopamine neurons in the nigrostriatal tract are lost. This suggests that a large redundancy of the nigrostriatal pathway or compensatory mechanisms in other pathways exist that correct for the loss of nigrostriatal pathway until a critical point is reached (4, 6).

Typically the symptoms of Parkinson's disease do not occur until after age 55 and affect approximately one percent of the elderly population worldwide. If the disease is left untreated, patients become rigid and akinetic. As the disease progresses, Parkinsonian patients lose the ability to care for themselves and suffer from complications associated with immobility such as pulmonary embolism and pneumonia (5).

The cause of Parkinson's disease is unknown. Several theories have been suggested including a genetic link, toxins and oxidative stress. It appears that in the vast majority of cases, the disease is not genetically determined. While there are well documented cases of families with a high incidence of Parkinson's disease, these cases constitute only a small fraction of Parkinsonian patients (3-5,7,8).

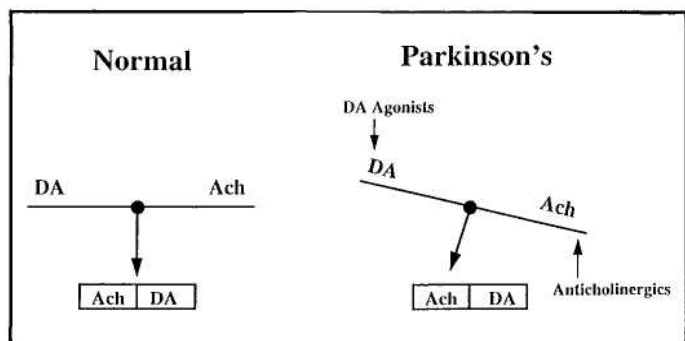

Fig. 2. Relative amounts of dopamine (DA) and acetylcholine (ACh) in the striatum of normal (left) and parkinsonian patients (right). Addition of a dopamine agonist or an anticholinergic agent attempts to restore the proper balance between DA and ACh in the Parkinsonian patient.

Normal adults experience approximately one percent loss of striatal dopamine per year. Given that Parkinsonian symptoms do not appear until later in life and only until after 70 percent or more of striatal dopamine is depleted, it is possible that Parkinson's disease results from two processes; a specific disease-related insult that does not reduce the dopamine content to symptomatic levels combined with the gradual loss of neurons during normal aging. This may explain why Parkinson's disease is a progressive disorder of late onset. Thus, the progression of symptoms may not necessarily be the result of an active disease process but rather may be the effects of aging superimposed on the initial insult. That is, the neuronal destruction may have occurred early in life but the symptoms do not appear until later in life when additional neurons are lost during normal aging (4).

Certain drug therapies can also produce Parkinsonian-like symptoms. Most notable are dopamine receptor antagonists used in the treatment of schizophrenia (haloperidol, chlorpromazine) and emesis (metoclopramide, prochlorperazine). The antihypertensive agent reserpine can also produce Parkinsonian-like symptoms because of its ability to deplete neuronal stores of dopamine. By preventing the uptake of dopamine into storage vesicles, reserpine makes dopamine available for destruction by monoamine oxidase (MAO) present within the nerve terminal. The Parkinsonian-like symptoms associated with these drugs are reversible and subside upon discontinuing the drug or decreasing the dose.

## PHARMACOTHERAPY

Symptoms associated with Parkinson's disease result from an imbalance between dopamine (deficiency) and acetylcholine (excess). Current drug therapy focuses on restoring the balance between these two neurotransmitters. In theory, any drug that can penetrate the blood brain barrier and produce an effect that results in the activation of dopamine receptors or in the blockade of muscarinic receptors should be of value in treating Parkinson's disease. The diagram in Figure 2 depicts the relative amounts of dopamine and acetylcholine in normal and Parkinsonian patients. Addition of either a dopamine agonist or an anticholinergic (muscarinic antagonist) in a Parkinsonian patient helps to restore the proper balance between these two neurotransmitters. Bear in mind that the current drug therapies treat only the symptoms of the disease; they do not cure or appear to alter the long term course of the underlying disease.

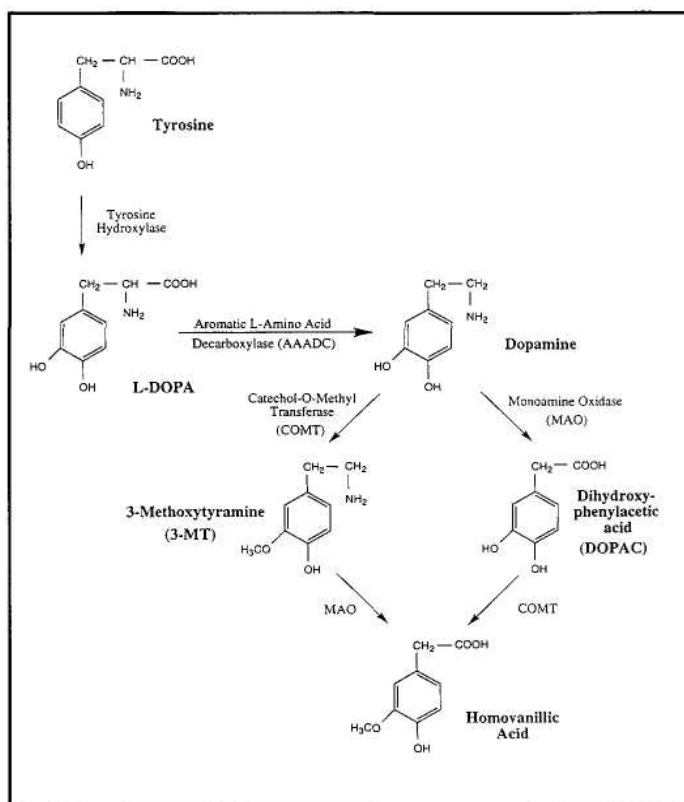

Fig. 3. Synthetic and metabolic pathways of dopamine.

## L-DOPA

Levo-dihydroxyphenylalanine (L-DOPA) is the amino acid precursor to dopamine. It is absorbed through the blood brain barrier by an active transport system. Once into the brain, L-DOPA is taken up into the nerve terminal and decarboxylated by aromatic L-amino acid decarboxylase (AAADC) to form dopamine (Figures 3 and 4). Apparently, there are enough surviving neurons for the synthesis and release of dopamine to occur and produce a therapeutic effect. Dopamine itself cannot be used because it does not pass through the blood brain barrier; it is too highly ionized and is not a substrate for the active transport system. Of all the L-DOPA administered, about one percent enters the brain while the remainder is decarboxylated in the periphery. Therefore, 99 percent of the L-DOPA that is administered is wasted in the sense that it is metabolized before it can get to the site of action in the brain (4).

### Study Question

Based on information in Figures 3 and 4, suggest other drugs or mechanisms which may be useful in the treatment of Parkinson's disease.

L-DOPA is rapidly absorbed from the small intestine by an active transport system for aromatic amino acids. Peak plasma concentration occurs in 30 to 90 minutes following oral administration. Plasma half-life is relatively short; 1 to 3 hours. However, the brain half-life is longer because L-DOPA is taken up by neurons (protecting it from metabolism) and stored.

One important food-drug interaction with regard to L-DOPA involves dietary protein. Ingested proteins are hydrolyzed to amino acids in the gastrointestinal tract prior to their absorption. These amino acids will compete with L-DOPA

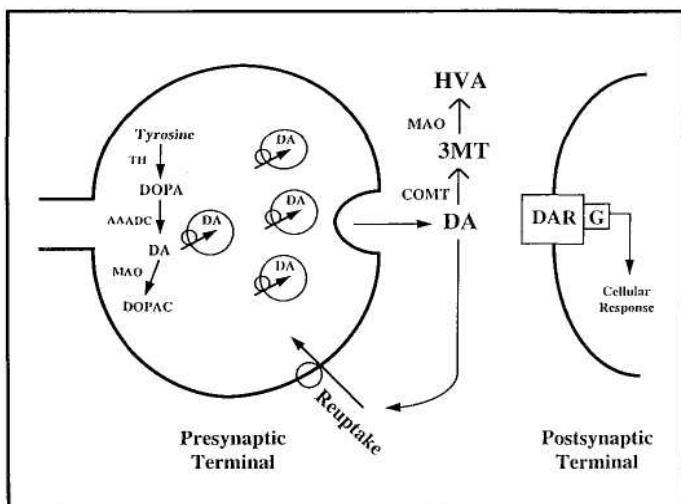

Fig. 4. Synapse depicting the synthesis, storage, release, post-synaptic receptor interaction, metabolism and reuptake of dopamine.

for absorption carrier sites in the small intestine and slow the movement of L-DOPA into the blood stream. Pharmacokinetic data substantiate that the administration of L-DOPA with food delays absorption and reduces peak plasma concentrations. Dietary amino acids can also compete with L-DOPA for active transport sites at the blood brain barrier. Consequently, the therapeutic effects of intravenously administered L-DOPA can also be influenced by diet (5).

The side effect profile of L-DOPA can be categorized into early and late occurring events. The most common side effects that occur early in therapy are nausea and vomiting. Hypotension and cardiac arrhythmias are also possible in the initial days of therapy but are not as common. These initial side effects are peripheral in origin (*i.e.*, do not involve the CNS) and are mediated by dopamine. L-DOPA itself has few, if any, pharmacological actions. Therefore, these side effects can be reduced or eliminated by the addition of a peripheral inhibitor of AAADC, the enzyme that converts L-DOPA to dopamine (see below). Alternatively, administration of vitamin supplements containing vitamin B6 (pyridoxine), a cofactor for AAADC, will increase the peripheral conversion of L-DOPA to dopamine resulting in more side effects and a reduced therapeutic effect.

Side effects that occur later in therapy (2-4 months) include nightmares, hallucinations, psychosis and abnormal, involuntary movements such as dyskinesia or dystonia. These delayed side effects are of central origin and occur following administration of relatively high doses. Consequently, these side effects cannot be alleviated by the addition of a peripheral inhibitor of AAADC but instead are reversed or controlled by reducing the dose. This can be problematic given that reducing the dose may result in loss of some of the beneficial effects of therapy (9).

During the first few years of L-DOPA therapy, the patient usually has smooth, day-long control of the symptoms. However, as the disease progresses, problems begin to arise. During the course of the day, the patient may experience "peak-dose dyskinesia" which are involuntary movements occurring at the time of peak plasma levels - too much dopamine. Later in the day, the patient may experience "end-of-dose hypokinesia"; Parkinsonian symptoms occurring at the time of low or subtherapeutic plasma concentration. These changes are referred to as the "on-off phenom

enon" or the "wearing off phenomenon". In some instances, the "on" portion may occur with the rising plasma concentrations rather than the peak concentrations and the "off" portion occur with the falling concentrations rather than the troughs. As a result, the on-off in some patients may occur within relatively short periods of time. In either case, the motor fluctuations tend to follow the kinetics of L-DOPA and, therefore, are fairly predictable (3,5).

The theory of why this form of on-off occurs later in therapy is based on the progressive loss of dopamine neurons. In newly diagnosed patients (*i.e.*, mild Parkinsonism), there are enough neurons still present to adequately synthesize and store enough dopamine to offset the rise and fall of L-DOPA plasma concentrations. As the disease progresses, more neurons die and post synaptic receptors adapt by upregulating or becoming supersensitive. As a result, with fewer neurons, the synthetic and storage capabilities of dopamine are lessened and the sensitivity of the dopamine receptors is heightened. Now, the range of therapeutic plasma concentrations of L-DOPA becomes much more narrow. The peak plasma concentration represents too much dopamine and produces dyskinesias. The trough concentration represents not enough dopamine and results in Parkinsonian symptoms. Dietary factors and dosing regimens become very important at this point. Strategies to reduce the frequency of the on-off phenomenon include low protein diet, continuous gastric infusion, sustained release formulations or giving smaller doses more frequently(2).

Another type of on-off phenomenon has been described in which the fluctuations between mobility and immobility are random. That is, the changes do not appear to follow the kinetics of L-DOPA. The mechanism for this form of on-off is unclear but may involve the interaction of several factors including pharmacokinetic and pharmacodynamic changes associated with chronic, high-dose L-DOPA therapy. Whereas it is possible to treat the predictable fluctuations with changes in dosage, frequency and route of administration, the random on-off phenomenon is difficult, if not impossible, to treat(2, 5).

### Carbidopa

As stated above, only one percent of an orally administered dose of L-DOPA reaches the CNS because of decarboxylation in the periphery. The conversion of L-DOPA to dopamine in the periphery is responsible for some of the side effects associated with L-DOPA therapy. These problems can be alleviated by administration of carbidopa, a peripheral inhibitor of AAADC. Carbidopa inhibits AAADC by forming a covalent inhibitory complex with the enzyme's cofactor pyridoxal phosphate, a form of vitamin B6 (10). Carbidopa does not penetrate the blood brain barrier because it is too highly ionized and is not a substrate for the active transport system. Therefore, it stays in the periphery. If the drug were to get into the CNS, it would negate L-DOPA therapy because L-DOPA would not be converted to the active form dopamine (4).

The addition of carbidopa to L-DOPA therapy offers a number of advantages including: (i) reduction in the dose of L-DOPA by 75 percent; (ii) reduction of all of the peripheral side effects (but not the central side effects); and (iii) no need to avoid vitamin B6 supplements. The L-DOPA/carbidopa combination product is Sinemet®. Rarely will L-DOPA therapy be used without carbidopa or some other inhibitor of AAADC.

L-DOPA is the most effective drug therapy for Parkinson's disease and is considered the mainstay of treatment. Early in the course of the disease, improvement in the three cardinal features of the disease is nearly complete along with improvement in handwriting and speech. There is also an increase in the patient's sense of well being and ability to function in society secondary to improvement of symptoms. However, as the disease progresses, L-DOPA therapy tends to fail and additional drugs may be added to the regimen. The drugs discussed below are used primarily as adjuncts. They may be used alone in the early stages of Parkinson's disease but their major role is as add-on therapy in later stages of the disease (3, 7).

#### Patient Scenario

*DK is a 65 year old female with advanced Parkinson's Disease. Her husband cares for her full-time and confides in you that ever since the physician increased her dose of Sinemet<sup>®</sup>, she has been acting goofy; she talks to people who do not exist and she wants to stay in at night because she claims the night air makes her hair fall out. Explain why DK is acting "goofy". Are there any changes in or additions to DK's drug regimen that may alleviate these symptoms?*

#### Bromocriptine (Parlodel<sup>®</sup>) and Pergolide (Permax<sup>®</sup>)

Bromocriptine and pergolide are dopamine receptor agonists. Theoretically, these drugs should offer some advantages over L-DOPA because they do not require active transport mechanisms for absorption from the GI tract or for passage through the blood brain barrier. Furthermore, these drugs do not rely upon functional dopamine nerve terminals for synthesis and release of the active agent. The side effect profile of these two agents is similar to L-DOPA; nausea, vomiting, hypotension but with a potentially higher incidence of hallucinations than L-DOPA. In addition, bromocriptine has the potential to produce severe orthostatic hypotension following the first dose(5).

In clinical practice, bromocriptine and pergolide are no more effective than L-DOPA. The putative selectivity of bromocriptine for the D<sub>2</sub> dopamine receptor subtype does not appear to offer any therapeutic advantage. (The dopamine receptor family is covered in detail in lectures on schizophrenia where the pharmacology of dopamine receptor subtypes is better defined with antagonists.) The role in therapy of these two agents is relegated to use as adjuncts to L-DOPA therapy during periods of excessive on-off or when higher doses of L-DOPA are required but cannot be tolerated(2,5,7).

#### Amantadine (Symmatrel<sup>®</sup>)

The mechanism of action of amantadine is not clear. It appears to cause release and inhibit reuptake of dopamine (Figure 4). It may have anticholinergic activity as well which can contribute to its antiparkinsonian effects (Figures 1 and 2). Side effects tend to be relatively mild and include dizziness, nausea and vomiting (3,5).

The use of amantadine is limited to mild cases of Parkinson's disease or as an adjunct to L-DOPA. A drawback to its use is its apparent loss of efficacy after 4-8 weeks of therapy. Interestingly, amantadine was introduced initially (and is still used) for the prevention and treatment of influenza A. Its potential use as an antiparkinsonian agent

was discovered by accident when the Parkinsonian symptoms of patients being treated for the flu improved during the course of amantadine treatment (4).

#### Benzotropine (Cogentin<sup>®</sup>) and Trihexyphenidyl (Artane<sup>®</sup>)

Benzotropine and trihexyphenidyl are two examples of muscarinic cholinergic receptor antagonists. Their mechanism of action with regard to the treatment of Parkinson's disease is to block the relative excess of acetylcholine in the striatum to restore the balance between acetylcholine and dopamine (Figures 1 and 2). These drugs are helpful in reducing tremor but not the rigidity or slowness of movement. Side effects of these agents are predictable and are based on blockade of the parasympathetic nervous system. In addition, the sedation and mental confusion often associated with anticholinergics tend to be more pronounced in the elderly and, therefore, an important concern in many Parkinsonian patients.

Prior to the use of L-DOPA, anticholinergics were the most effective drugs for the treatment of Parkinson's disease. Today, anticholinergics are used as adjuncts to L-DOPA therapy. They are used in patients with mild forms of Parkinson's disease, or in patients who cannot tolerate or who do not respond to L-DOPA therapy. All anticholinergics used in the treatment of Parkinson's disease are equally effective. However, be aware that an individual patient may tolerate or respond to one preparation better than another (2,5,7).

#### Selegiline (Eldepryl<sup>®</sup>)

Selegiline is a relatively selective inhibitor of monoamine oxidase B (MAO-B). MAO-B is the predominate form of monoamine oxidase in the striatum and is responsible for the majority of oxidative metabolism of dopamine in this region. Consequently, inhibition of this enzyme should result in more dopamine being available for release (Figures 3 and 4). Selegiline is metabolized to amphetamine and methamphetamine which may also play a role in producing an antiparkinsonian effect by increasing the release of dopamine (3).

Selegiline is also being looked at as a possible neuroprotective agent. One theory suggests that the neuronal loss associated with Parkinson's disease results from the formation of oxygen free radicals from MAO-mediated deamination of dopamine. Selegiline has also been shown to prevent the Parkinsonian syndrome associated with administration of the toxin N-methyl-4-phenyl-1,2,3,6-tetrahydropyridine (MPTP) by inhibiting the MAO-B mediated formation of the toxic metabolite 1-methyl-4-phenylpyridium (MPP<sup>+</sup>). If oxygen free radicals or an MPTP-like toxin is responsible for Parkinson's disease, then selegiline may be useful in slowing or preventing the progression of this disease (7). Recent studies, however, have failed to demonstrate with any definitive proof that selegiline is neuroprotective with regard to idiopathic Parkinson's disease (3-5,7).

Selegiline alone is well tolerated; insomnia and anxiety are the most commonly cited side effects. At recommended doses, selegiline is not associated with the potential for eliciting a hypertensive crisis as seen with the non-selective MAO inhibitors used in the treatment of depression. At doses of 10 mg/day or less, selegiline does not inhibit the metabolism of peripheral catecholamines or exogenous indirect acting sympathomimetics such as tyramine found in

certain drinks and foods (wine, cheese). However, at doses above 10 mg/day, selegiline loses its selectivity for MAO-B and may produce this reaction. In addition, selegiline, like the non-selective MAO inhibitors, has been observed to produce hyperthermia and convulsions following administration of the opioid analgesic meperidine (Demerol®)(5).

In early stages of Parkinson's disease, selegiline may be used alone. More commonly, it is used in combination with L-DOPA because it allows for a lowering of the dose of L-DOPA as well as increasing the time between doses. It is of limited value, however, in patients with advanced Parkinson's disease (5).

### Patient Scenario

*Sy Kosis is a 72 year old male diagnosed with Parkinson's disease six years ago. He is fairly well controlled with current therapy but complains of some "good days and some bad days." His daughter is concerned about him taking diphenhydramine (25 mg) for his allergies. Will the diphenhydramine be beneficial, harmful or have no effect with regard to the symptoms of Parkinson's disease in this patient? Are there any other concerns about the use of diphenhydramine in this patient?*

### POTENTIAL NEW THERAPIES

Glutamate is the major excitatory neurotransmitter in the CNS. Recent research has focused on the glutamate receptor as a site of drug action in the treatment of various diseases including Parkinson's disease, schizophrenia, epilepsy and stroke. Given that glutamate is one of the excitatory neurotransmitters in the striatum, it has been suggested that blockade of glutamate transmission may be beneficial in the treatment of Parkinson's disease (6, 11). For example, in some animal models of Parkinson's disease, glutamate antagonists can relieve some of the signs and symptoms of the disease. The dose of L-DOPA needed to alleviate these signs can be dramatically reduced by combining L-DOPA with a glutamate antagonist. MPTP-induced Parkinsonism can be prevented by pretreating with glutamate antagonists(6-8,11). Lamotrigine, an anticonvulsant that inhibits the release of glutamate, may be helpful in improving some of the clinical signs and symptoms of Parkinson's disease (12).

### Study Question

*Use a diagram similar to the one in Figure 2 to show the imbalance that exists between dopamine and glutamate and describe the mechanism of drugs that may restore this imbalance.*

The information below is provided in a handout at the end of the lecture series on Parkinson's disease. The students are asked to consider the study problem and be ready to discuss their answers following a live demonstration of the model in class the following week.

### RAT MODEL OF PARKINSON'S DISEASE

The nigrostriatal tract is a major pathway in the basal ganglia that controls posture and movement. The cell bodies of these neurons lie in the substantia nigra and the axons project to the striatum where the nerve terminals release dopamine. Dopamine activates postsynaptic dopamine receptors located in the striatum. Loss or destruction of the nigrostriatal neurons appears to be the cause of movement

problems in Parkinson's disease. Note that there are two nigrostriatal tracts in the brain (both humans and rats); one on the left side and one on the right side.

In the rat model of Parkinson's disease, the neurotoxin 6-hydroxydopamine (6-OHDA) is injected into the *right side of the brain* of a normal rat. The 6-OHDA is taken up into nerve terminals that have reuptake mechanisms for dopamine. Once inside the cell, 6-OHDA kills the entire neuron - cell body, axon and nerve terminal. Cell death occurs within 24<sup>^</sup>48 hours. At this point, the dopamine receptors in the right striatum are receiving no input; the nerves that release dopamine are absent. The striatum (post synaptic cell) adapts by making more dopamine receptors (upregulating or supersensitization). The left side of the brain did not receive the toxin and the receptors and neurons remain unchanged (normal). There is now an imbalance of dopamine receptors between the left striatum and the right striatum.

If a full dopamine agonist is administered systemically (PO, IV or SC) to a normal rat, the rat's response will be an increase in motor activity — mostly sniffing, gnawing and random movement in its cage. If a full dopamine agonist is administered systemically to a rat previously injected with 6-OHDA into the right side of the brain, the rat's motor behavior will be a constant circling to the left.

1. Draw and label the neuronal connections of the left and right nigrostriatal pathways of a rat receiving an injection of 6-OHDA into the right side of the brain.
2. Which side of the brain is receiving greater stimulation of dopamine receptors when a full dopamine agonist is administered systemically? Why?
3. If the rat circles to the left when a full dopamine agonist is administered, which direction will it turn if amphetamine is given systemically to the same rat? Why? (Amphetamine causes the release of dopamine from nerve terminals.)
4. What direction will the rat turn if a dopamine reuptake inhibitor is administered systemically?

### CONCLUSION

The intent of the above information is to provide a clear and organized overview of the drug therapy for Parkinson's disease with the opportunity to reinforce the material through discussions and problem solving exercises. The student evaluations for this portion of the course have been overwhelming positive. Students indicate that the patient scenarios are helpful in understanding the connection between the pharmacology of the drugs and their therapeutic applications. The scenarios also provide the students a break from the didactic lecture and give them a chance to reflect on the material and ask other related questions. The demonstration of the Parkinsonian rat model has also been viewed very favorably. The pharmacotherapeutics sequence is taught without a laboratory and, therefore, this demonstration (and others occurring later in the sequence) offers another useful method of reinforcing material.

*Am. J. Pharm. Educ.*, **61**, 179-183(1997);received 1/21/97,accepted 4/15/97.

### References

- (1) Rang, H.P., Dale, M.M., Ritter, J.M. and Gardner, P. *Pharmacology*, Churchill Livingstone, New York NY (1995) pp. 524-531.
- (2) Fischer, P.-A., "Parkinson's disease and its existing therapy," in *Inhibitors of Monamine Oxidase B: Pharmacology and Clinical Use in Neurodegenerative Disorders*, (edit. Szelenyi, I.) Birkhäuser Verlag,

- Basel, Switzerland (1993) pp. 51-71.
- (3) Korczyn, A.D., "Parkinson's disease," in *Psychopharmacology: The Fourth Generation of Progress*, (edits. Bloom, F.E., Kupfer, D.J.) Raven Press, Ltd., New York NY (1995) pp. 1479-1484.
- (4) Neumeyer, J.L., Booth, R.G., "Drugs used to treat neuromuscular disorders: antiparkinsonism agents and skeletal muscle relaxants," in *Principles of Medicinal Chemistry*, 4th ed., (edits. Foye, W.O., Lemke, T.L., Williams, D.A.) Williams & Wilkins, Media PA (1995) pp. 232-242.
- (5) Standaert, D.G., Young, A.B., "Treatment of central nervous system degenerative disorders," in *Goodman and Gilman's The Pharmacological Basis of Therapeutics*, 9th ed., (edits. Hardman, J.G., Gilman, A.G., Limbird, L.E.) McGraw-Hill, New York NY (1996) pp. 503-512.
- (6) Greenamyre, J.T., "Glutamate-dopamine interactions in the basal ganglia: relationship to Parkinson's disease," *J. Neural. Transm. [Gen. Sect.]*, **91**,255-269(1993).
- (7) Kopin, I.J., "The pharmacology of Parkinson's disease therapy: An update," *Ann. Rev. Pharmacol. Toxicol.*, **32**, 467-495(1993).
- (8) Mizuno, Y., Mori, H. and Kondo, T., "Potential of neuroprotective therapy in Parkinson's disease," *CNS Drugs*, **1**, 45-56(1994).
- (9) Mendis, T., Barclay, C.L. and Mohr, E., "Drug-induced Psychosis in Parkinson's disease," *CNS Drugs*, **3**, 166-174(1996).
- (10) Roskoski, R., *Biochemistry*, W.B. Saunders Company, Philadelphia PA (1996) p. 407-408.
- (11) Ossowska, K., "The role of excitatory amino acids in experimental models of Parkinson's disease," *J. Neural. Transm. [P-D Sect.]*, **8**, 39-71(1994).
- (12) Zipp, F., Burklin, F., Stecker, K., Baas, H. and Fischer, P.-A., "Lamotrigine in Parkinson's disease — A double blind study," *ibid.*, **10**, 199-206(1995).
-