

Montana Tech Library
Digital Commons @ Montana Tech

Graduate Theses & Non-Theses

Student Scholarship

Spring 2018

SITE WIDE WATER BALANCE OF THE EAST BOULDER MINE

Kelly Hertel
Montana Tech

Follow this and additional works at: https://digitalcommons.mtech.edu/grad_rsch



Part of the [Environmental Sciences Commons](#)

Recommended Citation

Hertel, Kelly, "SITE WIDE WATER BALANCE OF THE EAST BOULDER MINE" (2018). *Graduate Theses & Non-Theses*. 165.
https://digitalcommons.mtech.edu/grad_rsch/165

This Thesis is brought to you for free and open access by the Student Scholarship at Digital Commons @ Montana Tech. It has been accepted for inclusion in Graduate Theses & Non-Theses by an authorized administrator of Digital Commons @ Montana Tech. For more information, please contact sjuskiewicz@mtech.edu.

SITE WIDE WATER BALANCE OF THE EAST BOULDER MINE

by
Kelly Hertel

A thesis submitted in partial fulfillment of the
requirements for the degree of

Masters of Science in Environmental Engineering

Montana Tech

2018



Abstract

Water management within the Mining Industry is an important issue. Operating a mine is a water intensive process and in order to meet the goals of mining operations, water resources must be tracked and monitored, not only to comply with state and federal regulations, but also to optimize the mining operations. Sibanye-Stillwater (formerly known as Stillwater Mining Company) operates two underground mines, the Stillwater Mine and the East Boulder Mine, both located in the Beartooth Mountain Range of South Central Montana. The East Boulder Mine targets platinum group metals found within the J-M Reef geological formation. This thesis focuses on developing an operational, site wide water balance for the Easter Boulder Mine under base flow conditions as well as different proposed flow scenarios. Flow data from 2015 was provided by Sibanye-Stillwater to quantify the water balance and model the proposed flow scenarios. Since the mine is operational, historical data can be used to quantify many of the uncertainties associated with creating a water balance, therefore minimizing the need of probabilistic software and allowing for the use of Microsoft Excel to be used to create the water balance.

Different flow scenarios were proposed with the intention to improve water treatment plant operating efficiencies. An onsite water treatment plant is used to remove contaminants in the water caused by the underground mining operations. Nitrate, a byproduct of the underground blasting agent, is the main contaminate of concern for the East Boulder Mine. The proposed flow scenarios focused on the effects of changing the flow direction of the mine adit water within the system.

The results of the water balance indicate that it is possible to improve water treatment plant operating efficiencies by changing the onsite mine water flow direction. This research also identified the need for additional onsite flow monitoring and improvements made to the flow monitoring database. The results of this research can be used to make informed decisions in regards to mine operation and water resource management. The results of this thesis show that a water balance can be performed on an operational mine site and highlight possible improvements that can be made to water flow paths that may result in improved operational performance.

Keywords:

Operational water balance, mine water balance, water balance, mine water management, water resource management.

Dedication

I want to thank my friends, family, and fiancé. Without their continued support, encouragement, and love, I would not have been able to accomplish what I have today.

Acknowledgements

I wish to acknowledge and thank Dr. Daqian Jiang for being my thesis advisor and for taking the time to assist me with my thesis. I would also like to thank Dr. Glenn Shaw and Jeanne Larson for taking the time to be on my thesis committee and advising me throughout my graduate studies. I would like to thank Stillwater-Sibanye for providing me a thesis research topic and for their assistance along the way. I finally want to thank Montana Tech for the financial support to continue my education and for providing me with the tools to be successful upon graduation.

Table of Contents

ABSTRACT	II
DEDICATION	III
ACKNOWLEDGEMENTS	IV
LIST OF TABLES	VII
LIST OF FIGURES.....	VIII
LIST OF EQUATIONS	X
GLOSSARY OF TERMS.....	XI
1. INTRODUCTION	1
1.1. <i>East Boulder Mine</i>	2
1.2. <i>Motivation</i>	5
1.3. <i>Objectives</i>	5
2. DATA AND METHODOLOGY.....	7
2.1. <i>Water Balance</i>	7
2.2. <i>Water Flow Diagrams</i>	8
2.2.1. <i>Underground</i>	9
2.2.2. <i>Water treatment</i>	14
2.2.3. <i>TSF</i>	21
2.2.4. <i>Mill and Concentrator</i>	25
2.2.5. <i>Accumulation</i>	26
2.2.5.1. <i>Underground</i>	27
2.2.5.2. <i>TSF</i>	28
2.3. <i>Flow Scenarios</i>	30
2.3.1. <i>Flow Scenario 1</i>	30
2.3.2. <i>Flow Scenario 2</i>	31

2.3.3. Flow Scenario 3	32
3. RESULTS AND DISCUSSION	34
3.1. Base Flow	34
3.2. Flow Scenario 1	39
3.3. Flow Scenario 2	41
3.4. Flow Scenario 3	45
3.5. Comparison	46
4. SUMMARY	48
5. RECOMMENDATIONS	49
6. REFERENCES CITED	50

List of Tables

Table I: Total Mine Storage Capacity in Gallons	27
Table II: Underground Storage Capacity in Gallons	28
Table III: Surface Storage Capacity in Gallons	29
Table IV: Base Flow WTP Average TIN	38
Table V: WTP Base Flow Total Nitrogen Loading	39
Table VI: Flow Scenario 1 LAD Total Nitrogen Load.....	41
Table VII: Max Total Nitrogen Loads under MPEDS Permit.....	41
Table VIII: Average TSF Total Nitrogen Samples.....	43
Table IX: Flow Scenario 2 WTP Total Nitrogen Loading	44
Table X: Flow Scenario 3 LAD Total Nitrogen Load	46

List of Figures

Figure 1: East Boulder Map (SMC, 2016).....	2
Figure 2: Site Overview	3
Figure 3: Mining Methods	4
Figure 4: Conceptual Flow Diagram.....	9
Figure 5: Underground Flow Diagram	10
Figure 6: Riser Water Flow Rate	11
Figure 7: Recycled Mine Water Flow Rate	12
Figure 8: Underground Effluent Mine Water Flow Rate.....	13
Figure 9: Water Treatment Plant Flow Diagram	15
Figure 10: Water Treatment Plant Influent Flow Rate	17
Figure 11: Water Treatment Plant Effluent Flow Rate.....	18
Figure 12: Water Treatment Plant Bypass Flow Rate	19
Figure 13: Water Treatment Plant Influent TIN Concentration.....	20
Figure 14: TSF Flow Diagram.....	21
Figure 15: NRCS SNOTEL Monthly SWE for 2015	23
Figure 16: LAD Pond to TSF Flow Rate	24
Figure 17: Mill and Concentrator Flow Diagram	25
Figure 18: Flow Scenario 1	31
Figure 19: Flow Scenario 2.....	32
Figure 20: Flow Scenario 3.....	33
Figure 21: 2015 Base Flow Water Balance	34

Figure 22: NRCS SNOTEL Historical Precipitation Accumulation	36
Figure 23: USGS Historical Boulder River Discharge	37
Figure 24: Flow Scenario 1 Water Balance	40
Figure 25: Flow Scenario 2 Water Balance	42
Figure 26: Flow Scenario 3 Water Balance	45

List of Equations

Equation

(1)	7
(2)	20
(3)	27
(4)	27
(5)	29

Glossary of Terms

Term	Definition
TSF	Tailings Storage Facility
WTP	Water Treatment Plant
ANFO	Ammonium Nitrate
MPDES	Montana Pollution Discharge Elimination System
MDEQ	Montana Department of Environmental Quality
LAD	Land Application Disposal
MBBR	Moving Bed Biofilm Reactor
NRCS	National Resource Conservation Service
SNOTEL	Snow Telemetry
TIN	Total Inorganic Nitrogen
TSS	Total Suspended Solids

1. Introduction

Many forms of mining require the use of water. Water is used for a variety of tasks within the mining industry such as mineral processing, dust control, slurry transport, and mine dewatering (Prosser, Wolf, & Littleboy, 2011). Water management within the mining industry is an important issue and it begins with understanding where the water comes from and where the water goes (McPhail, 2005). Mine operation is a water intensive process and in order to meet the goals of mining operations, water resources must be tracked and monitored, not only to comply with state and federal regulations, but also to optimize operations (Wade, 2014).

Creating a water balance is a useful method to optimize water management within the mining industry (McPhail, 2005). Water balances are used to meet site specific water management goals while aiding in life of mine decisions (Davis, Engineer, Alexieva, & Zurakowski, 2013). Major mining companies such as Freeport-McMoRan, Rio Tinto, and Barrick, all require a water balance as a part of their individual water management programs (ICMM, 2012). By performing a water balance, potential unknown gains or losses to the system may come to light. Understanding where the water goes in the system is critical for regulatory compliance and daily operations. For example, Lonmin uses a water balance model to optimize the reuse of poor-quality process water at their Marikana operations (ICMM, 2012). After performing a water balance on base flow conditions, different flow scenarios can also be considered. The effect that a proposed flow scenario has on the water balance can be used in operations and decision making processes. By evaluating different flow scenarios in regards to the water balance, flow adjustments can be made to optimize operations.

1.1. East Boulder Mine

The East Boulder Mine, operated by Sibanye-Stillwater (formerly known as Stillwater Mining Company), is an underground platinum and palladium mine located 23 miles south of Big Timber, MT. The East Boulder targets the J-M Reef formation, a geologic formation located within the Beartooth Mountain range in Montana, as seen in red in Figure 1. The J-M Reef contains platinum group metals which are used in vehicle catalytic converters to reduce air pollution, electronics, and jewelry (Wilburn & Bleiwas, 2004). Sibanye-Stillwater operates two mines within the Beartooth Mountain range, the Stillwater Mine and the East Boulder Mine. This thesis will only focus on the East Boulder Mine.

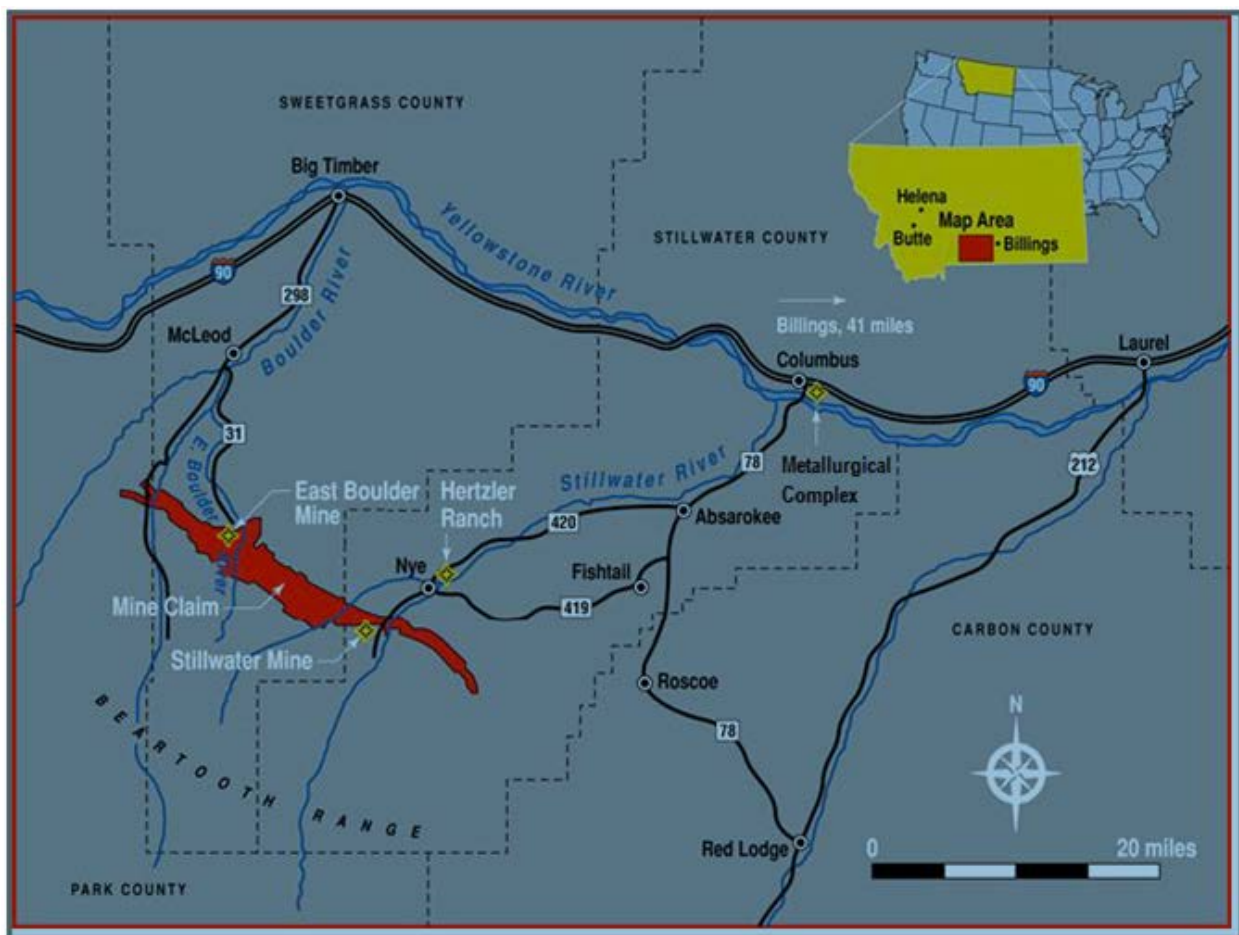

Figure 1: East Boulder Map (SMC, 2016)

The East Boulder Mine can be split up into four main subsections, shown in Figure 2; underground operations, the water treatment plant (WTP), the tailings storage facility (TSF), and the mill and concentrator.

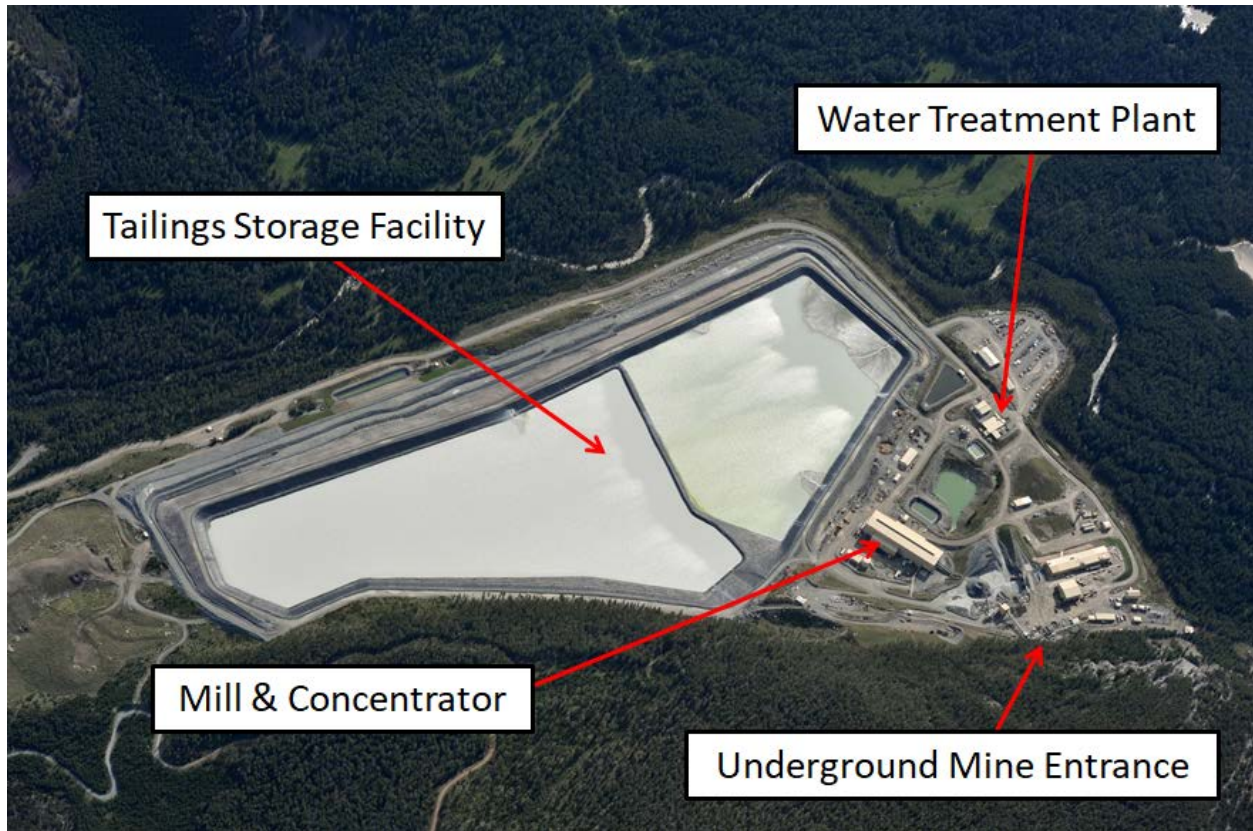

Figure 2: Site Overview

The East Boulder Mine uses a multitude of mining methods to extract the platinum group metals. Of the different mining methods that Sibanye-Stillwater uses at the East Boulder Mine, the ramp and fill method is predominate (Figure 3). This method creates an access ramp perpendicular to the ore vein. Once the ore body is found, the ore is drill, blasted, and removed through a series of horizontal stopes (Mining, 2011). After the ore has been removed, the Mill and Concentrator process ore and waste rock from the mine. The void space in the underground mine is then filled with backfill material, consisting of crushed waste rock from the Mill. The

waste rock is processed into sand by the mill and sent underground for backfill as slurry mixed with water.

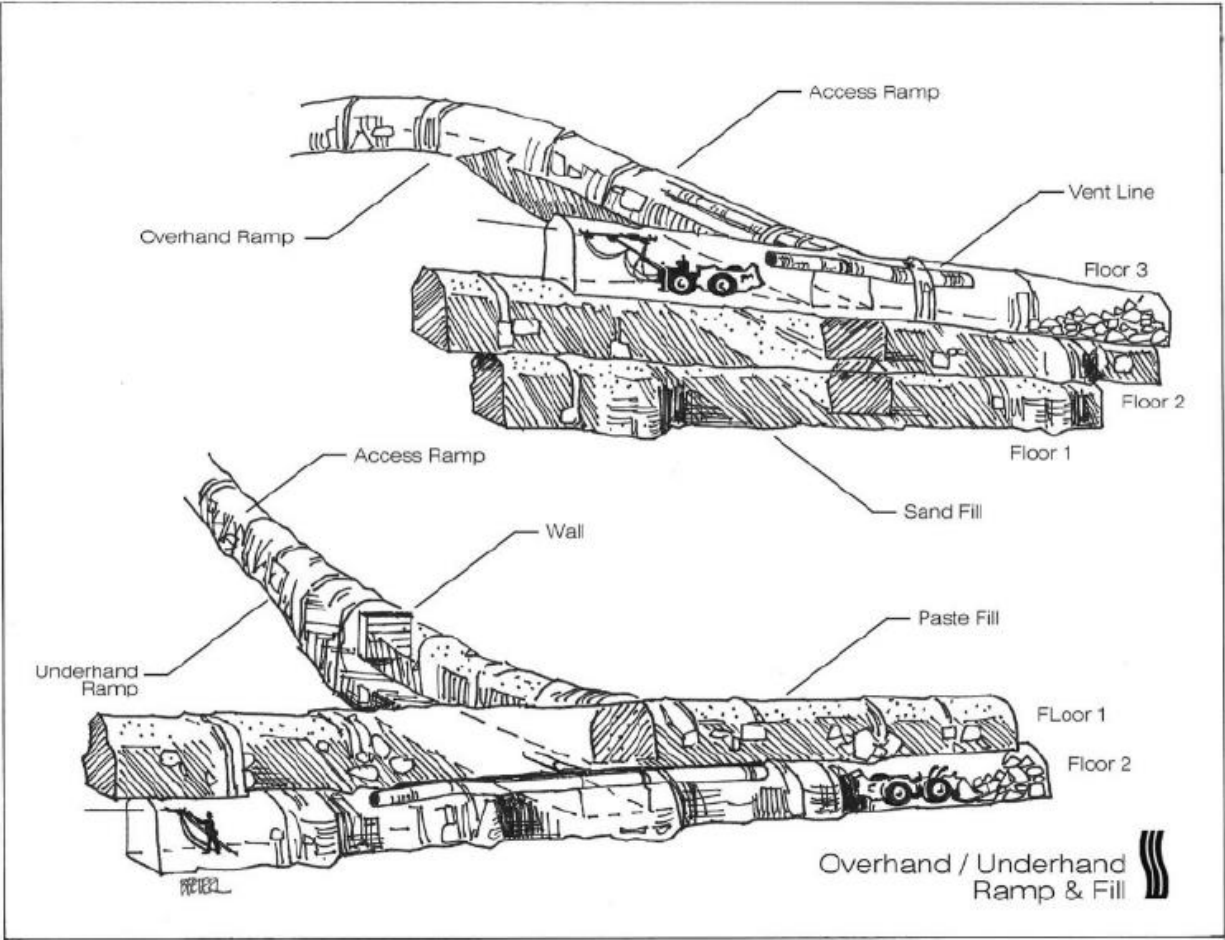

Figure 3: Mining Methods

All mining methods use a blasting agent called Ammonium Nitrate Fuel Oil (ANFO) to remove waste rock and ore from the mine. After blasting, ANFO will leave behind water soluble byproducts such as ammonia, nitrite, and nitrate, which pose a threat to surface water and groundwater (Brochu, 2010).

Water that is discharged from the water treatment plant to the percolation pond will infiltrate into the groundwater. Discharge to the percolation pond is regulated by the Montana

Department of Environmental Quality (MDEQ) under the mine's Montana Pollution Discharge Elimination System (MPDES) permit (MT0026808) (MDEQ, 2015).

Due to increasing flow rate and changes to the MPDES permit effluent limits, the need for enhanced water treatment is critical (WWC Engineering, 2017). In order to meet water quality standards, areas for improvement include clarification, and nitrogen removal (WWC Engineering, 2017). The MPDES permit discharge limits for nitrate and nitrite as N is 8.9 mg/L (MDEQ, 2015).

Understanding the complex flow paths of water within the mine is important not only as a means to keep track of the water, but also give insight into how the water interacts on the mine site.

1.2. Motivation

There are two main motivating factors for this study. The first comes from the standpoint of water resource management. Currently, there is not a site wide water balance for the East Boulder mine. Creating a water balance can highlight water use on the mine site and be used in water management strategies. In addition to a current base flow water balance, future mine development was incorporated and water balances were created under proposed flow scenarios. The second motivation behind this study stems from water quality and investigating improved nitrogen reduction with future development and flow scenario water balances. By changing the water flow path, water quality and operating efficiencies could potentially change.

1.3. Objectives

This thesis focuses on developing a water balance within the mine permit boundary for the 2015 operating year, in order to further understand mine water flows, optimize current

mining operations, and investigate potential total nitrogen reduction using different flow scenarios.

2. Data and Methodology

2.1. Water Balance

A water balance, a form of tracking and monitoring water flows, is accomplished by taking into account all water inflows and discharges from the mine site by utilizing a general mass balance equation, shown in Equation 1 (Adams et al., 1974).

$$Input = Output + Accumulation \quad (1)$$

From Equation 1, input represents water entering the system, output represents water exiting the system, and accumulation indicates water storage (Adams et al., 1974). Equation 1 can be expanded and rearranged to include all inputs and outputs of the system, allowing for site wide accumulation to be calculated. Equation 1 can be applied both on the system as a whole, as well as on individual systems within the mine site to show smaller scale accumulation and flows. The information obtained from Equation 1 was used to evaluate base flow conditions as well as all flow scenarios to allow for comparison of results.

Water balances can be performed at any stage of the mining process. For instance, some water balances focus on pre-mine development, and require probabilistic methods for determining unknown values within water balance, while other water balances can be performed during mining operations (Wade, 2014).

Since the East Boulder Mine is an operational mine, real data can be used for the water balance. Data from the 2015 operating year was chosen for the water balance it was the most recent and available data to work with. The 2015 operating year showed representational data, with relatively minimal upsets or abnormal operating conditions. By using tangible operational data, probabilistic water balance software is not required for this project, therefore a Microsoft Excel spreadsheet can be used for the calculations. The approach used in this project can be used

on operational mine sites to evaluate base flow conditions as well as visualize and report process flows, without the need of expensive software.

The water balance spreadsheet was created by classifying raw data from the mine site into inputs and outputs. From there, inputs and outputs were totalized individually and applied to Equation 1. Accumulation can then be calculated from Equation 1, which shows if the system is gaining or losing water. The general form of Equation 1 was applied to the TSF and underground mine to gain insight into how these processes affected the overall balance as well as understand the water balance of the individual system. Raw data was also manipulated into correct flow units and applied to the conceptual flow diagram, creating a quantitative flow diagram of the water balance.

2.2. Water Flow Diagrams

Figure 4 shows the water flows of the East Boulder Mine under base flow conditions.

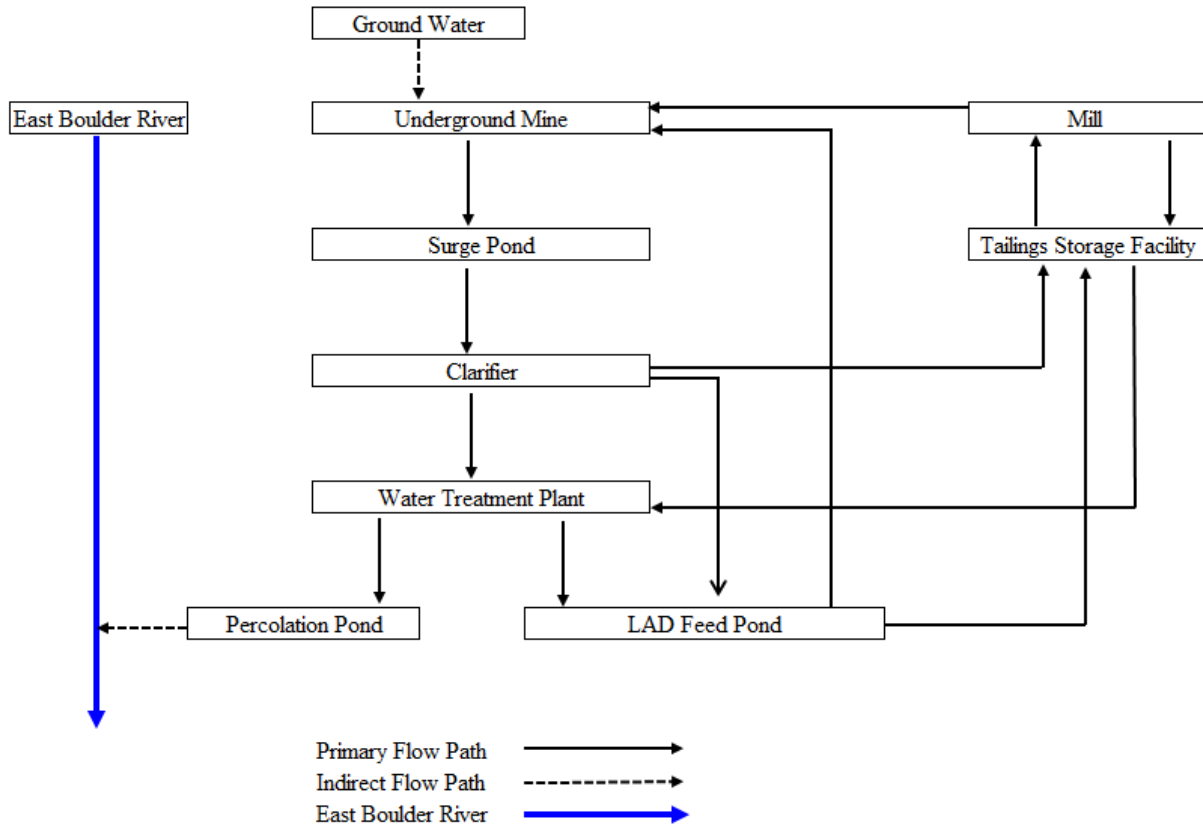

Figure 4: Conceptual Flow Diagram

2.2.1. Underground

Figure 5 shows the water flows in the underground mine under base flow conditions.

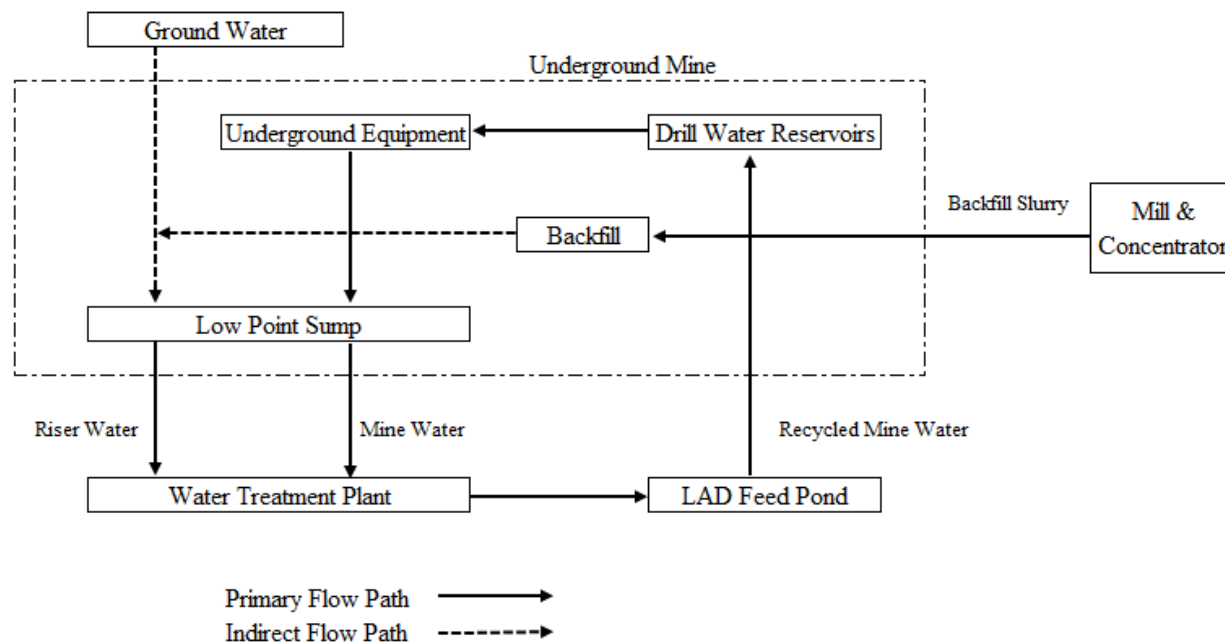

Figure 5: Underground Flow Diagram

There are three water inflows to the underground mine and one outflow. The incoming flows are riser water, recycled mine water, and backfill slurry. The effluent flow is the combined flows of riser water and mine water. The output from the underground mine flows to the water treatment plant. There is minimal tracking of water flows within the underground mine.

The main input to the underground mine comes from the underground mine as unaltered ground water, or riser water. The mine must be dewatered in order to gain access to the underground workings and prevent flooding. Riser water is pumped and collected in the low point sump. From there, the water will go to the water treatment plant. Riser water treatment is not measured as it enters the low point sump, but rather as it leaves the low point sump and enters the water treatment plant. Although riser water is measured as an effluent stream, the value is believed to be representative of the flow rate of ground water entering the mine. Riser water flow rate will change seasonally and can be seen in Figure 6. Riser water is not measured individually for total nitrogen, but is measured for nitrogen as riser water and mine water

combine to form water treatment influent. Water treatment plant influent is the effluent from the underground mine.

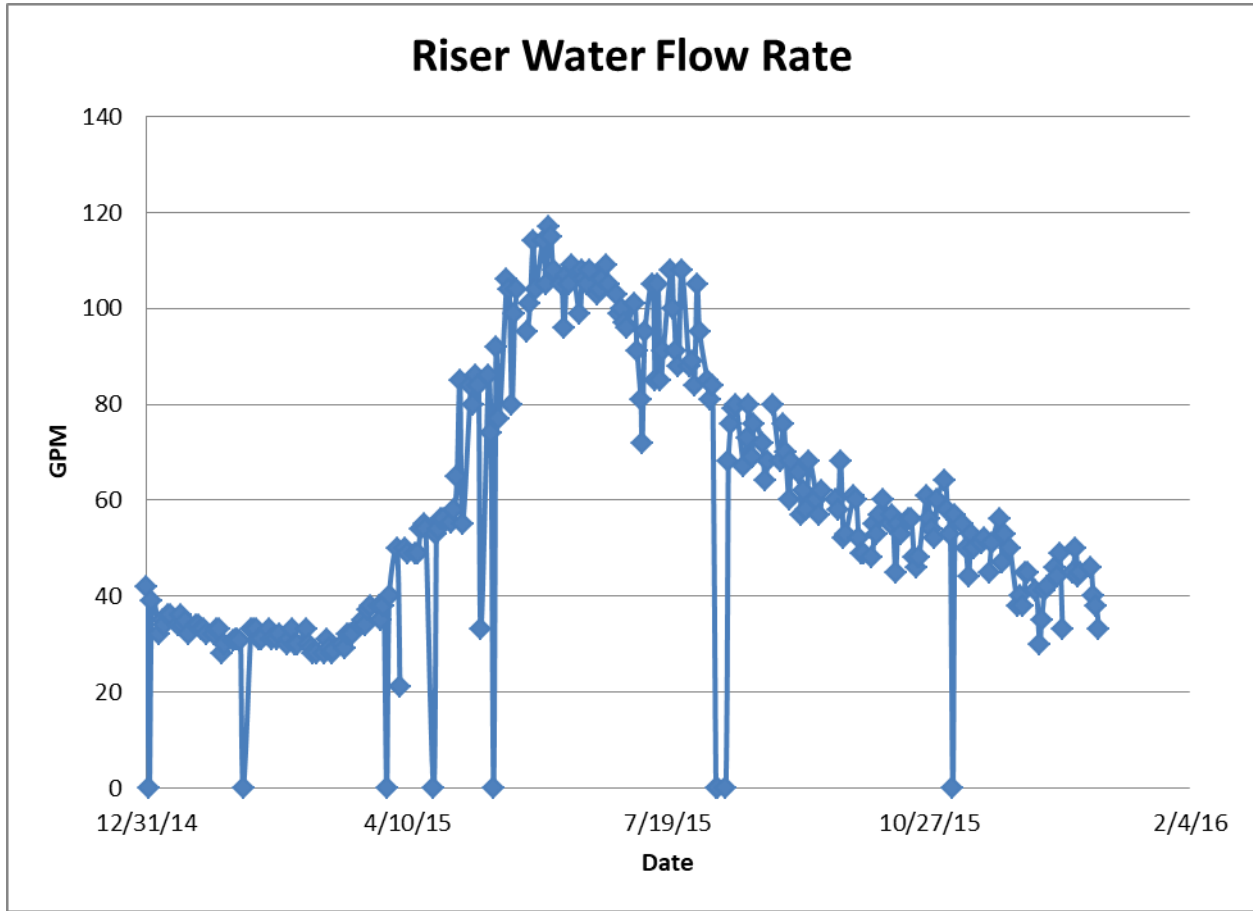

Figure 6: Riser Water Flow Rate

Water will also enter the underground operations in the form of mine recycle water. The entire mine site recirculates large volumes water for use in underground operations. When using totalizer flow meters on large recycle water streams, there is possibility to count water volumes multiple times. Because the East Boulder has large volumes of recycle water, the water balance was developed and balanced using average annual flow rates in gallons per minute (gpm). This

was done primarily to reduce the likelihood of counting recycle streams multiple times, although this error cannot be completely ruled out.

Recycled mine water is used by the underground mining equipment, such as jackleg drills. Mine water is stored in six drill water reservoirs located on each of the main underground levels of the underground mine. The underground mining equipment pulls water from drill water reservoirs. Flow rate data for recycled mine water to the underground mine can be seen in Figure 7.

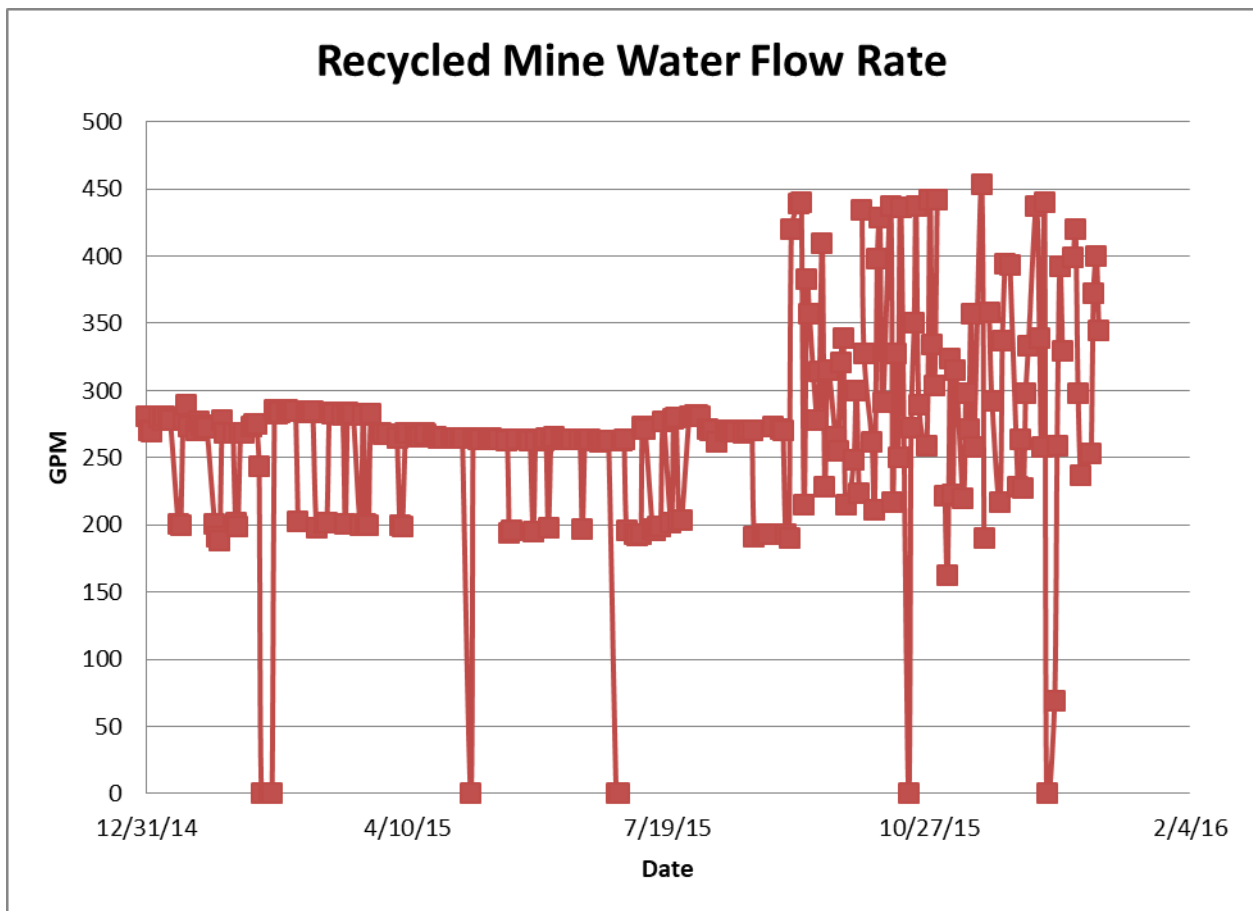

Figure 7: Recycled Mine Water Flow Rate

After the water is used by the underground equipment, the water drains to the low point sump, where the water will leave the underground mine and travel to the water treatment plant. Both riser water and mine water flow to the low point sump and then to the water treatment plant, but are tracked and monitored separately. Figure 8 shows mine water flow rates as the water leaves the underground mine and travels to the water treatment plant.

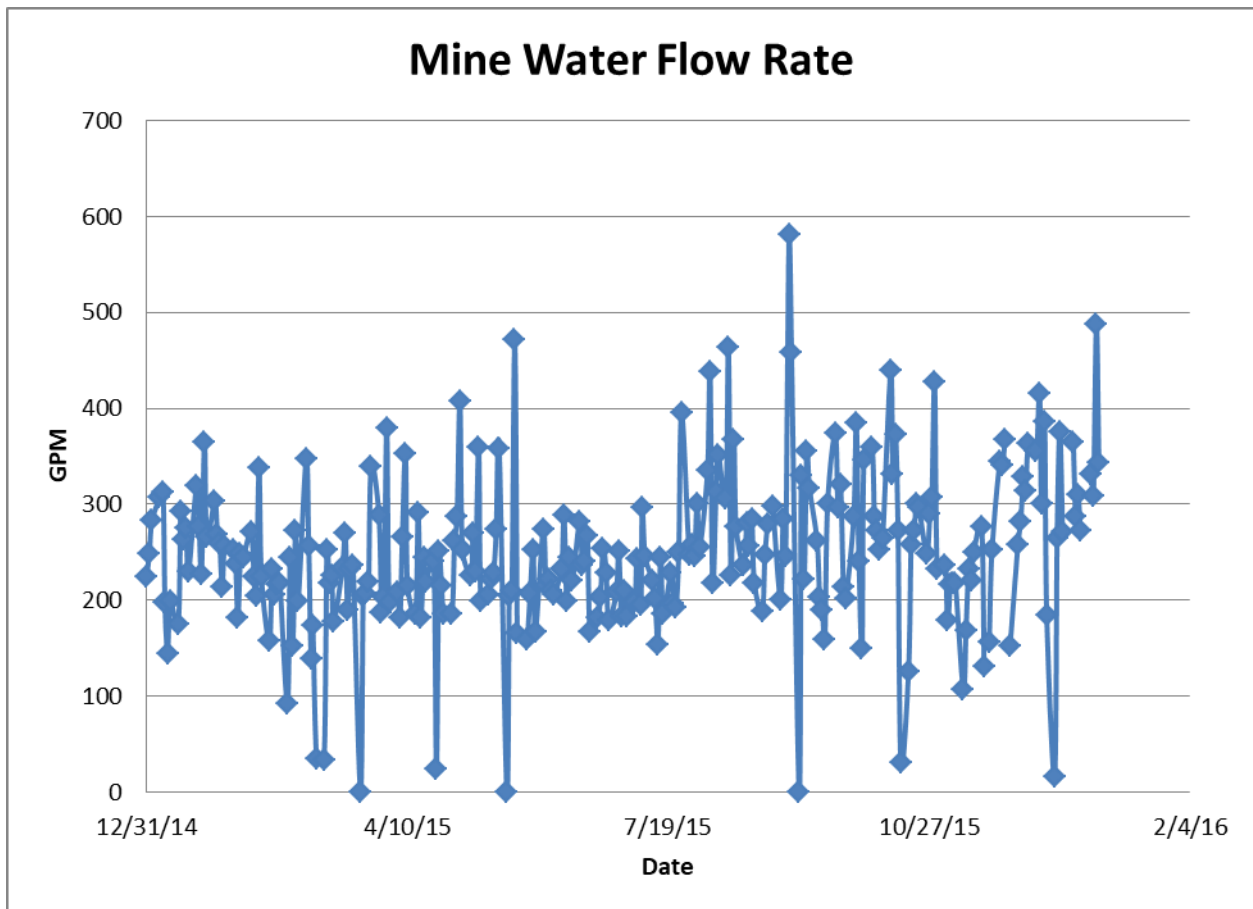

Figure 8: Underground Effluent Mine Water Flow Rate

Finally, water will enter the underground mine in the form of slurry for backfill material from the mill and concentrator. Backfill slurry is typically made up of 24% solids, mixed with water. The water from the backfill slurry will drain naturally to the low point sump and join the

riser water stream. The backfill slurry flow rate data was estimated by Sibanye-Stillwater and was corrected for percent solids in the stream and the mill and concentrator operational schedule to reflect an average annual flow rate.

Flow rate data was provided by Sibanye-Stillwater. Flow meters are attached to the low point sump, water treatment plant influent, and water treatment plant effluent recycle stream.

2.2.2. Water treatment

Figure 9 shows the water flows for the water treatment plant under base flow conditions.

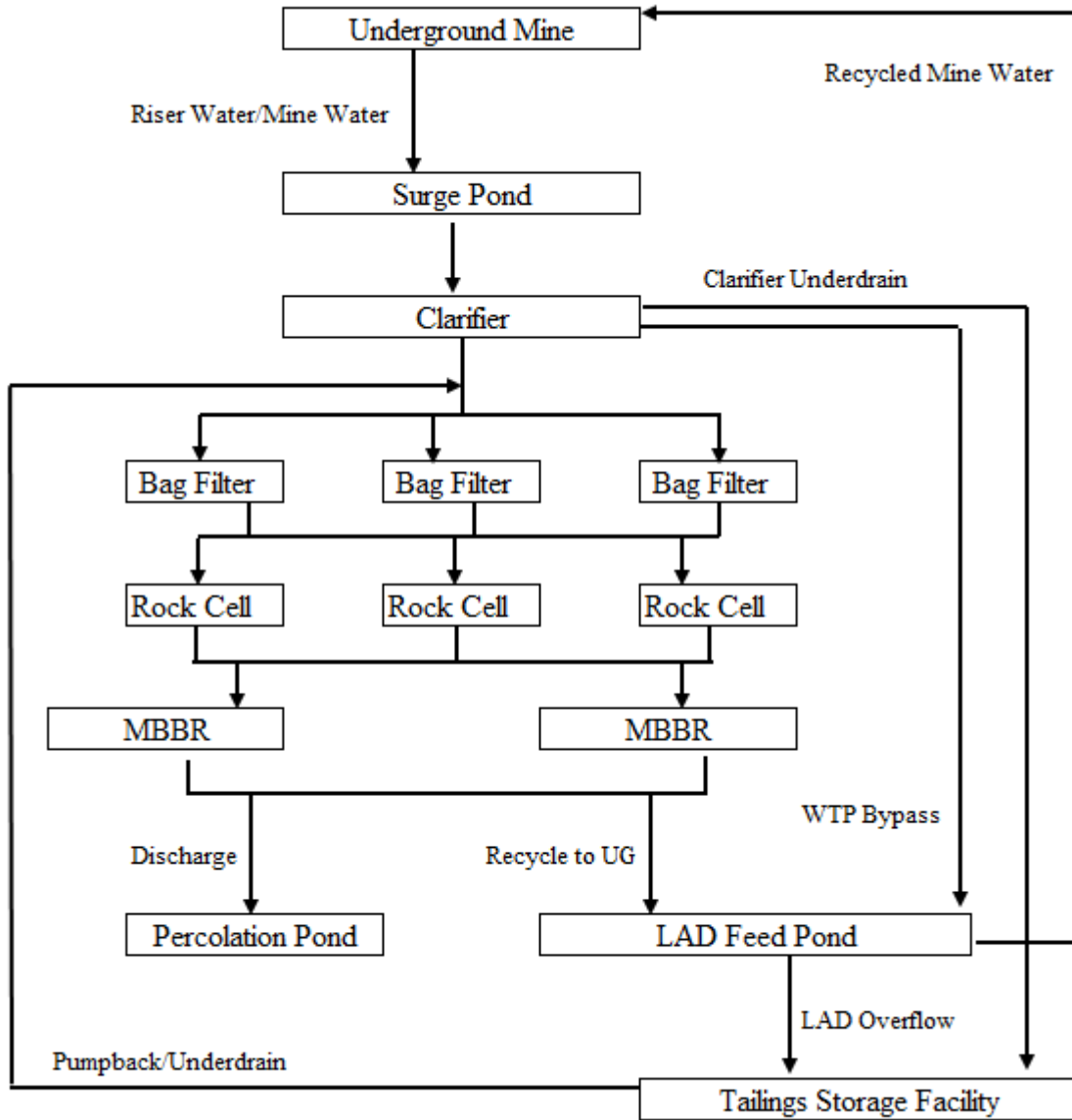

Figure 9: Water Treatment Plant Flow Diagram

There are two water inflows to the water treatment plant and two outflows. The incoming flows are underground mine effluent (riser water and mine water), and TSF underdrain and groundwater well pumpback system. The effluent flows are water treatment plant discharge and recycled mine water.

The water treatment plant's main purpose is to treat the underground mine effluent water. Water treatment processes consist of clarification and biological treatment processes to remove suspended sediments and blasting byproducts that may be present in the mine water (WWC Engineering, 2017). The biological treatment process uses rock cells as well as moving bed biofilm reactors (MBBR) to provide nitrification and denitrification treatment (Greyn, 2015). Suspended sediments are removed by low point sump settling, located in the underground mine, and with the use of a clarifier.

Water treatment plant influent flow rates are shown in Figure 10. Typical WTP influent is made up of both riser water and mine water streams. The water treatment plant influent flow data was provided by Sibanye-Stillwater. The main sampling and monitoring site for the East Boulder Mine is the water treatment plant, therefore most of the data was obtained from the water treatment plant records. Totalizer flow data was pulled from daily WTP records and monthly discharge reports. The daily flow data was collected at similar times in the morning on each work day, with time and date recorded. Daily WTP flow rates were not typically recorded over the weekends.

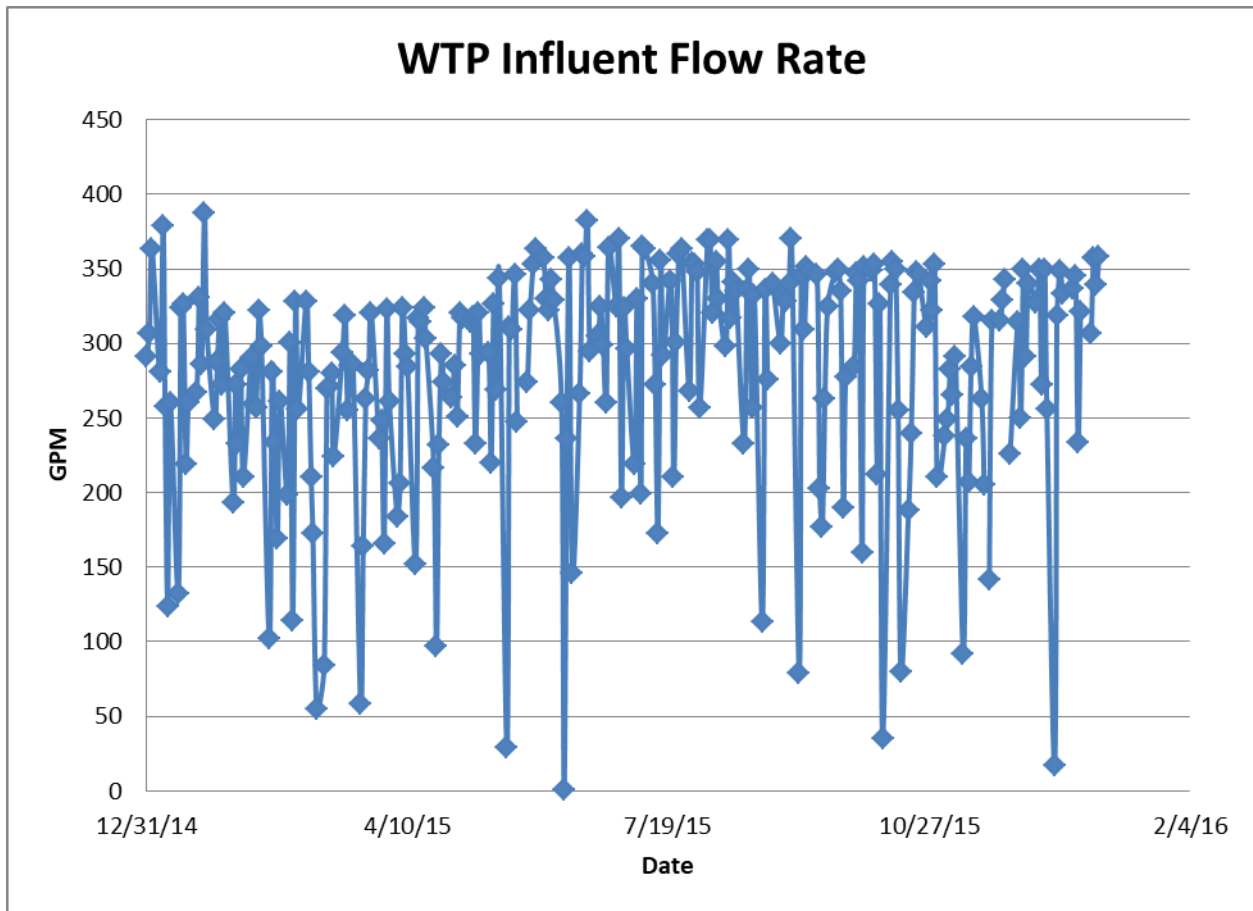

Figure 10: Water Treatment Plant Influent Flow Rate

In current conditions, water treatment effluent can be discharged to the percolation pond, as shown in Figure 11, or recirculated, as seen in Figure 9. The land application disposal (LAD) feed pond currently acts as mine water recycle pond and will later serve as the feed pond to the Boe Ranch LAD. Water that is recirculated can be sent back underground as mine water for use by underground mining equipment.

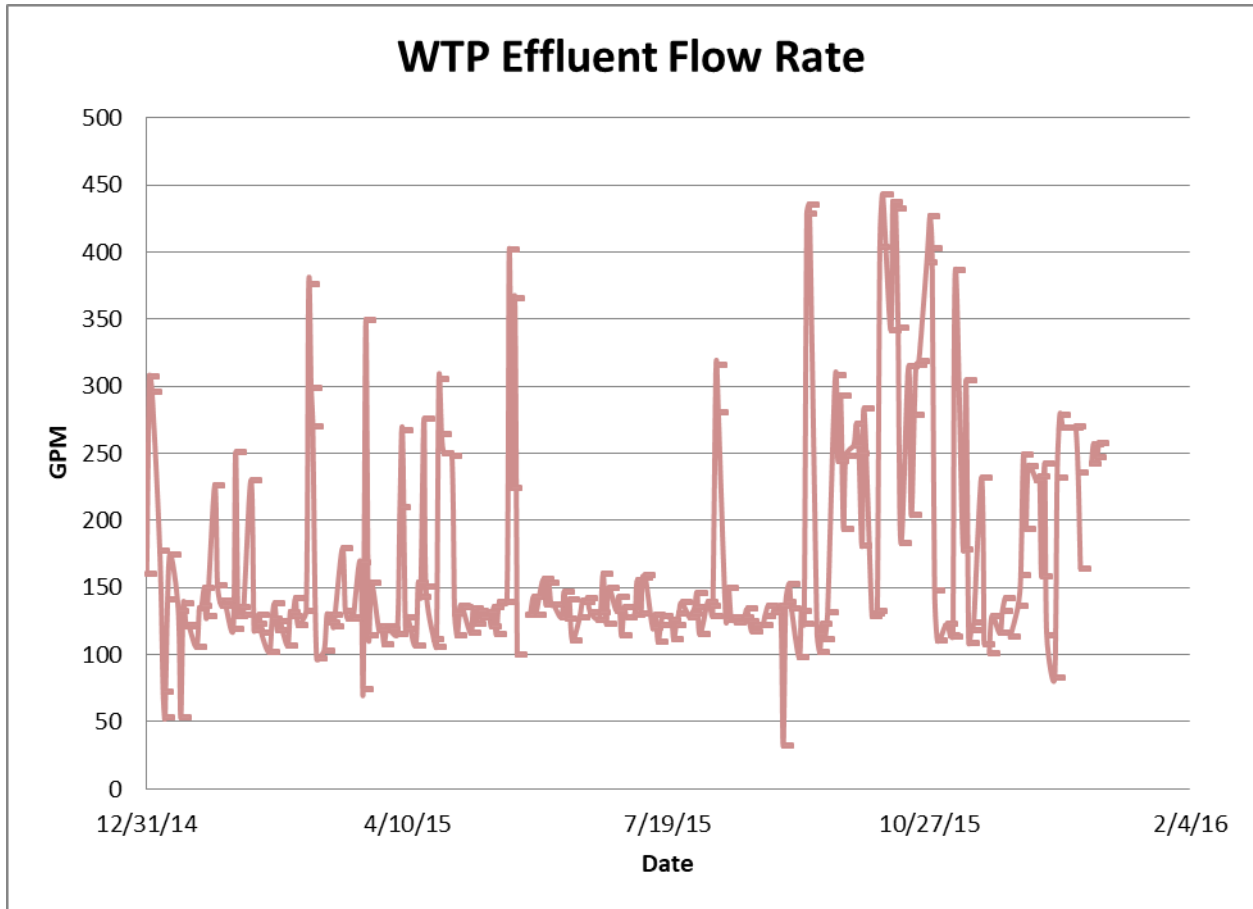

Figure 11: Water Treatment Plant Effluent Flow Rate

Water can also bypass the water treatment plant, and recirculate as mine water. Water treatment plant bypass flow rate data is shown in Figure 12. Sibanye-Stillwater provided bypass totalizer flow meter data that which was converted to annual average gallons per minute for the water balance.

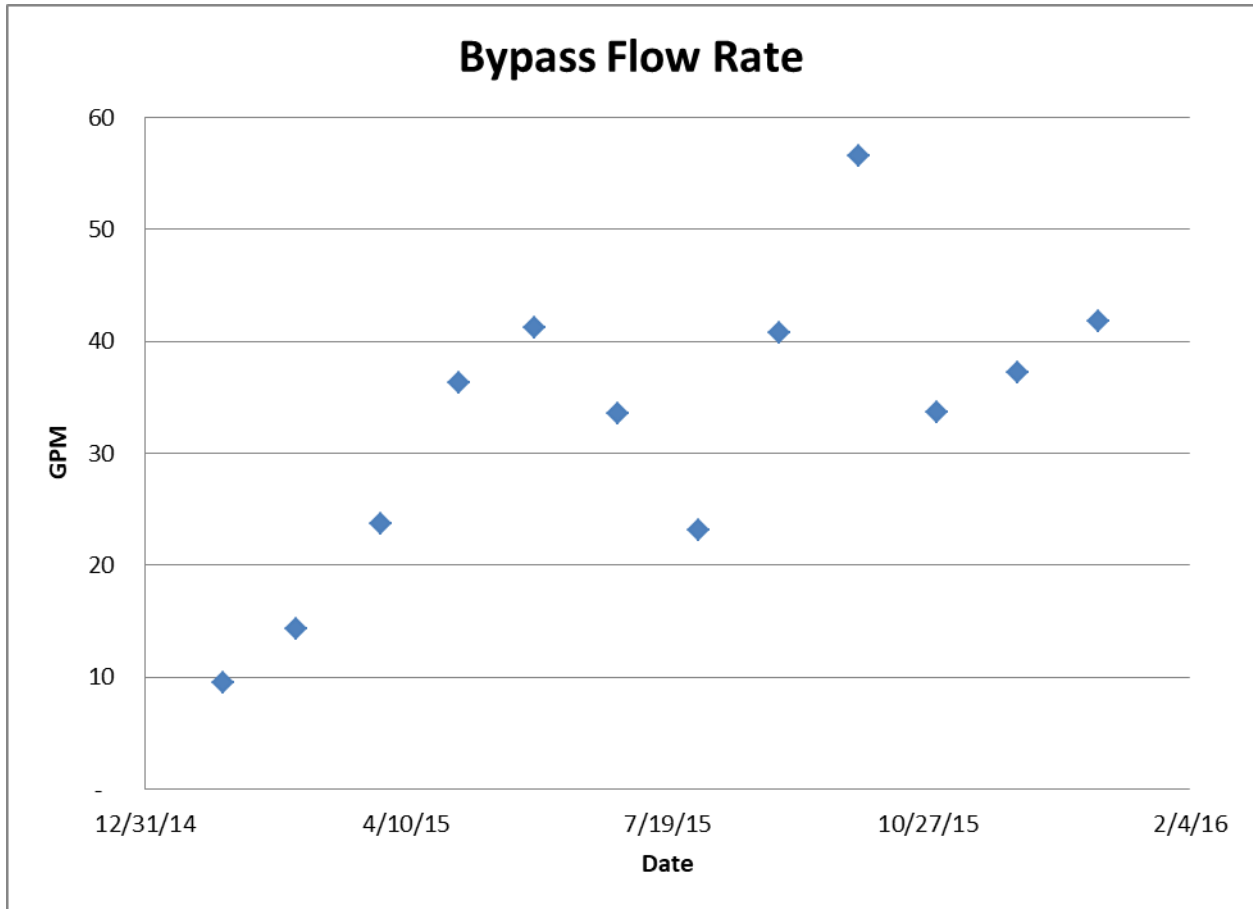

Figure 12: Water Treatment Plant Bypass Flow Rate

Water treatment plant influent and effluent total inorganic nitrogen (TIN) concentration can be seen in Figure 13. Water quality data was provided by Sibanye-Stillwater which was taken from onsite daily reports and monthly discharge reports.

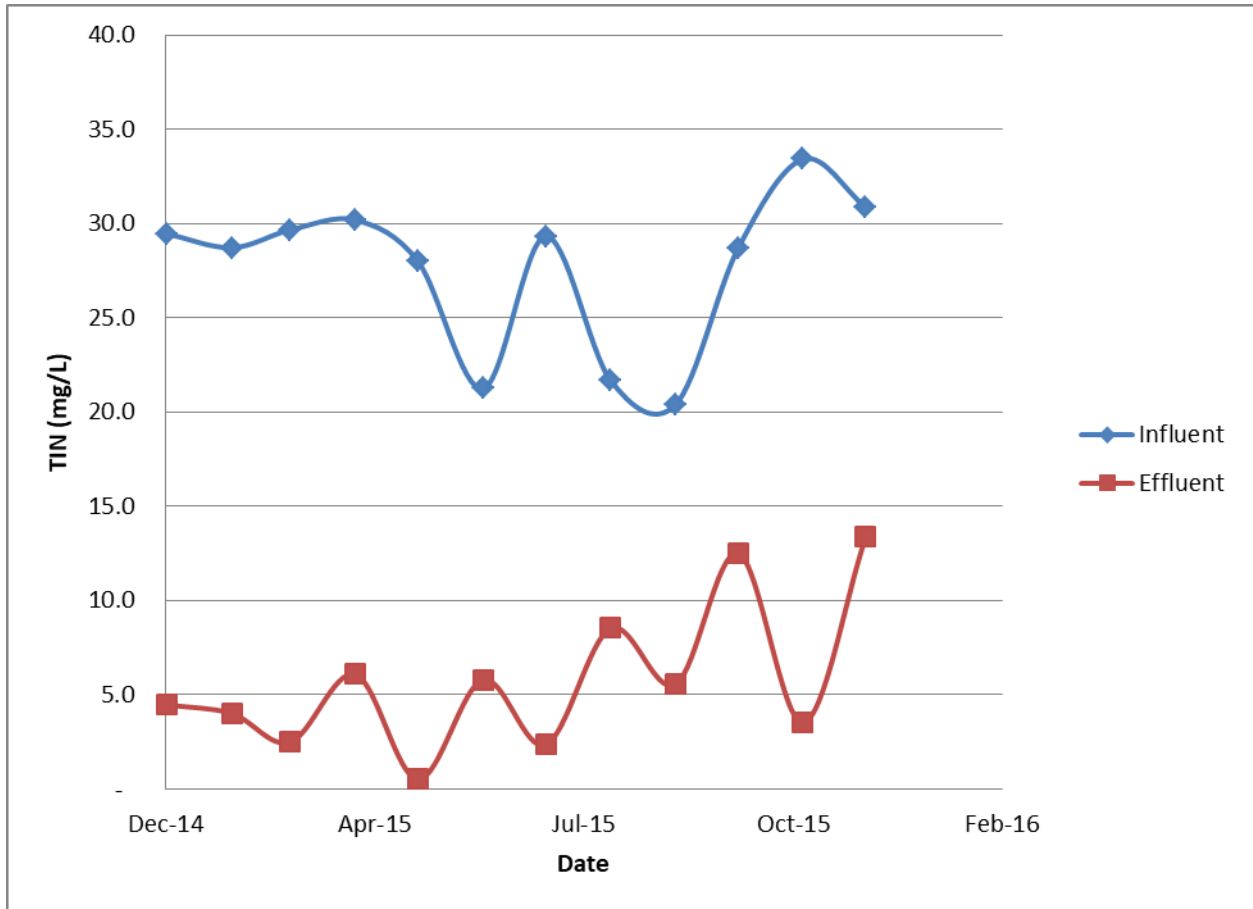

Figure 13: Water Treatment Plant Influent TIN Concentration

Nitrogen concentrations vary for both influent and effluent concentrations. An increase in underground mining activity can cause a pulse of high nitrogen concentration, or slug, to hit the water treatment plant, resulting in fluctuating influent water quality and removal efficiencies.

Nitrogen loads were calculated using Equation 2. Nitrogen removal could not be calculated under denitrification kinetic equations due to lack of data and small biomass concentrations in the TSF.

$$\text{Load} = \text{Flow Rate} \times \text{Concentration} \times \text{Conversion Factor} \quad (2)$$

2.2.3. TSF

Figure 14 shows the water flows for the tailings storage facility under base flow conditions.

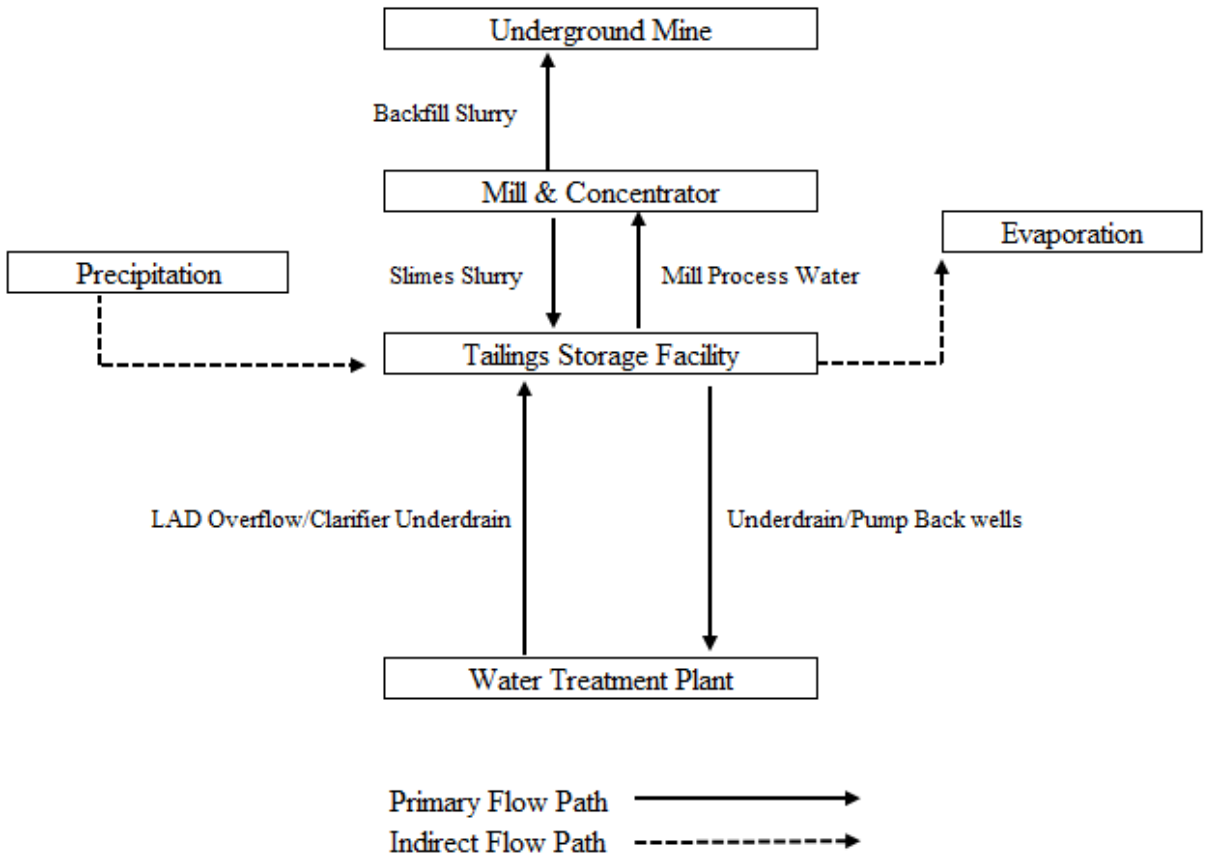

Figure 14: TSF Flow Diagram

There are three water inflows to the tailing storage facility and three outflows. The incoming flows are precipitation, LAD overflow and clarifier underdrain, and mill slimes slurry

from Mill and Concentrator. The effluent flows are the mill process water, evaporation, and underdrain flow.

Weather is monitored and tracked by the nearby National Resource Conservation Service (NRCS) Snow Telemetry (SNOTEL) site. Precipitation data was obtained from the NRCS SNOTEL site. The SNOTEL site showed 24.6 inches of total precipitation for the 2015 calendar year. Figure 15 is adjusted to align with the mine's calendar operating year and match the process flow data which was present on a calendar year basis and used in the water balance. The East Boulder Mine receives large amounts of precipitation in the form of snow. Total precipitation data includes total inches of rain and accounts for snow water equivalent (SWE) in total accumulated precipitation. Figure 15 shows the monthly precipitation for 2015.

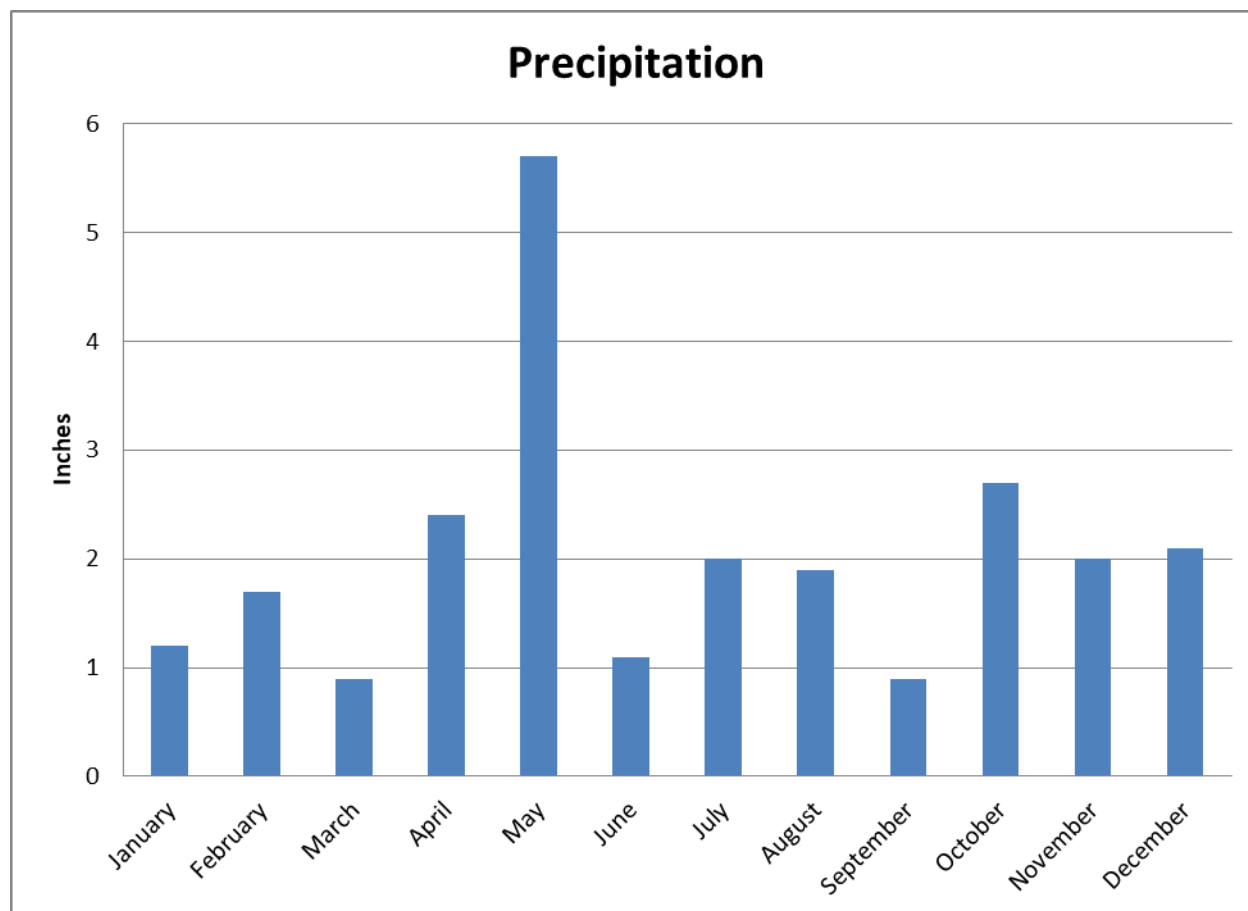

Figure 15: NRCS SNOTEL Monthly SWE for 2015

The East Boulder mine has two separate precipitation catchment basins on site, the percolation pond and the TSF. All precipitation that falls outside of the TSF will drain to the percolation pond and infiltrate out of the system. The precipitation volume that drains to the percolation pond was not calculated since it does not enter the mine water system. The precipitation that falls into the TSF was calculated by taking the area of the TSF and multiplying by the total annual depth of precipitation.

Figure 16 shows LAD overflow flow rate. The high flow rate spike seen in Figure 16 correlates with the increased recycled mine water flow rate of the same time frame seen in Figure 7. Flow rate to the LAD was too much causing water to be diverted to the TSF, by means of the

LAD overflow line. Data was provided by Sibanye-Stillwater. Clarifier underdrain flow rate was estimated to be 33 gpm by Sibanye-Stillwater.

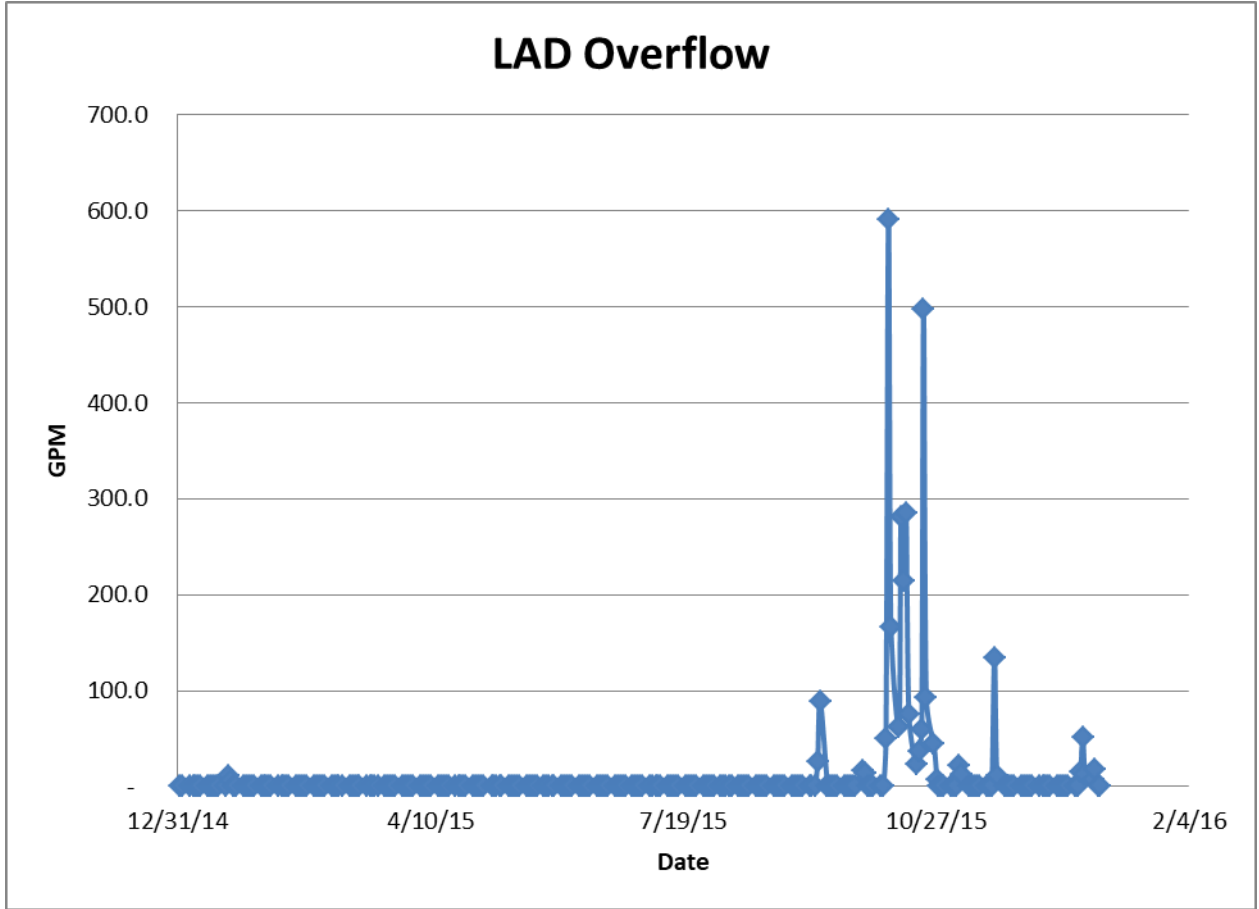

Figure 16: LAD Pond to TSF Flow Rate

Fine waste material is sent from the mill and concentrator to the tailings impoundment as slurry called the slimes. The slimes line is typically 16% solids. The slimes slurry flow rate data was estimated by Sibanye-Stillwater and was corrected for percent solids in the stream and the mill and concentrator operational schedule to reflect an average annual flow rate.

Outputs from the tailings storage facility include mill process water, underdrain flow, and evaporation. The amount of evaporation changes seasonally due to daily temperatures and heat

index (Knight Piésold Consulting, 2017). Weather is monitored and tracked by the nearby NRCS SNOTEL site. From the Detailed Design for Stage 6 TSF Expansion Report performed by Knight Piésold Consulting, annual evaporation was shown to be 34,501,640 gallons.

The other source of output for the tailings storage facility is underdrain flow and seepage. Groundwater wells were placed down gradient from the tailings storage facility to recapture possible leakage from the tailings storage facility. These wells pump into a lined pond which is then pumped back to the water treatment plant for additional treatment. Sibanye-Stillwater provided groundwater well pumpback system flow data as well as underdrain flow data.

2.2.4. Mill and Concentrator

Figure 17 shows the water flows for the Mill and Concentrator under base flow conditions.

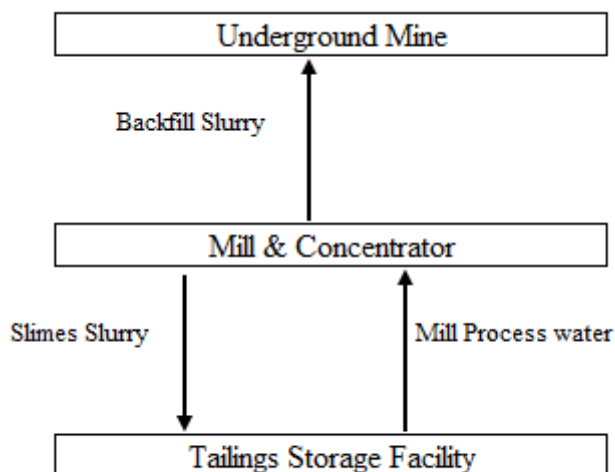

Figure 17: Mill and Concentrator Flow Diagram

There is one water inflow to the Mill and Concentrator and two outflows. The incoming flow is mill process water from the TSF. The effluent flows are mill byproducts; backfill slurry and slimes slurry. There is minimal tracking and recording of water flows within the Mill and Concentrator.

The Mill and Concentrator currently have an operations cycle of ten days operating and four days shut down for maintenance inspections and repairs, therefore the water demand for the Mill and Concentrator are not consistent. Sibanye-Stillwater provided estimated mill operating process water flow rate data. Due to the high volume of recycle water, and the fluctuation of Mill and Concentrator water, the resulting water balances were adjusted and corrected to take these facts into account. Processes within the Mill and Concentrator were not taken into account due to lack of data.

2.2.5. Accumulation

Accumulation in the water balance represents the change in storage for the mine. This can be represented as either a positive or negative change in accumulation, thus showing a gain or loss to the system. Since the WTP and Mill and Concentrator is a continuous treatment process, with no storage capacity, accumulation was not calculated for these sections of the water balance. The water balance was created using average annual flow rates in gallons per minute (gpm). Evaporation and precipitation was calculated in total gallons and applied to the overall water equation, but was not applied to the water balance flow diagram, since the focus is to show process flow rates.

Overall accumulation for the mine site was calculated using Equation 3, which shows the expanded water balance equation that was applied to the mine site under base flow conditions and adapted from Figure 4.

$$(Riser\ Water + Precipitation) - (Discharge + Evaporation) = (\Delta\ Storage) \quad (3)$$

Storage capacity should also be considered when looking at the change in storage. Base flow condition is considered ideal operating levels of all of the ponds, tailings impoundment, and sufficient water to run underground operations. Total mine storage capacity is shown in Table I.

Table I: Total Mine Storage Capacity in Gallons

Total Mine Storage Capacity	Gallons
Surface	151,762,038
Underground	1,625,726
Total	153,387,764

2.2.5.1. Underground

Accumulation for the underground mine was calculated using Equation 4, which shows the expanded water balance equation for the underground mine under base flow conditions and adapted from Figure 5.

$$(Riser\ Water + Recycled\ Mine\ Water + Backfill\ Slurry) - (Riser\ Water + Used\ Mine\ Water) = (\Delta\ Storage) \quad (4)$$

Underground storage capacity is shown in Table II.

Table II: Underground Storage Capacity in Gallons

Underground	Gallons
Low Point Sump	13,000
Crusher Decline	932,726
6450 Drill Water Reservoir	177,000
6700 Drill Water Reservoir	18,000
6900 Drill Water Reservoir	33,000
7200 Drill Water Reservoir	183,000
7500 Drill Water Reservoir	95,000
7900 Drill Water Reservoir	92,000
8200 Drill Water Reservoir	82,000
Underground Total	1,625,726

2.2.5.2. TSF

The tailings storage facility plays a significant role in storage capacity. It is the largest storage unit for water on the mine site, with a capacity of 148,000,000 gallons of water. Total surface storage capacity is listed below in Table III. The tailings storage facility is essentially a large lake that holds excess waste rock that cannot be processed and sent back underground as backfill material. The structure of the TSF is built with larger waste rock, then lined and filled with fine waste rock material, otherwise known as “slimes.” The TSF has a large amount of

entrained water, approximately 38 million gallons (Knight Piesold Consulting, 2017). Water from the TSF can be pulled from the underdrain and diverted to the water treatment plant for treatment.

Table III: Surface Storage Capacity in Gallons

Surface	Gallons
Nitrogen Collection Pond	860,259
Mine Water recycle Pond	1,174,000
Surge Pond	329,000
WTP Cells	486,246
Clarifier	33,929
Event Pond	660,000
Mill Reclaim Water Tank	67,958
Fresh Water Tank	150,646
TSF	148,000,000
Surface Total	151,762,038

Accumulation for the TSF was calculated using Equation 5, which shows the expanded water balance equation for the TSF under base flow conditions and adapted from Figure 14.

$$(Precipitation + LAD Overflow + Slimes Line + Clarifier Underdrain) - (Evaporation + Mill Process Water + TSF underdrain) = (\Delta Storage) \quad (5)$$

2.3. Flow Scenarios

2.3.1. Flow Scenario 1

All of the proposed flow scenarios represent potential future development of the East Boulder Mine and were developed from future mine planning. During each flow scenario, base flow rates were used to set key flow rates, such as Mill process feed water and underground mine water effluent. While attempting to keep flow rates, such as WTP influent and recycled mine water underground, similar to base flow conditions, different flow paths were investigated and the resulting water flows were developed.

Flow scenario 1 incorporates both the Boe Ranch LAD and percolation pond as two main outflows (Figure 18). The Boe Ranch LAD allows for the use of mine water to be used beneficially in an agricultural setting (SMC, 2002). Mine water will be pumped to the Boe Ranch facility and then applied to the agricultural field, using common irrigation equipment. The goal of the LAD system is to facilitate contamination immobilization through vegetation uptake, surface soil binding, and evaporation (Chambers, 2014). The use of the LAD system allows for more operating flexibility and treatment and disposal optimization (SMC, 2002).

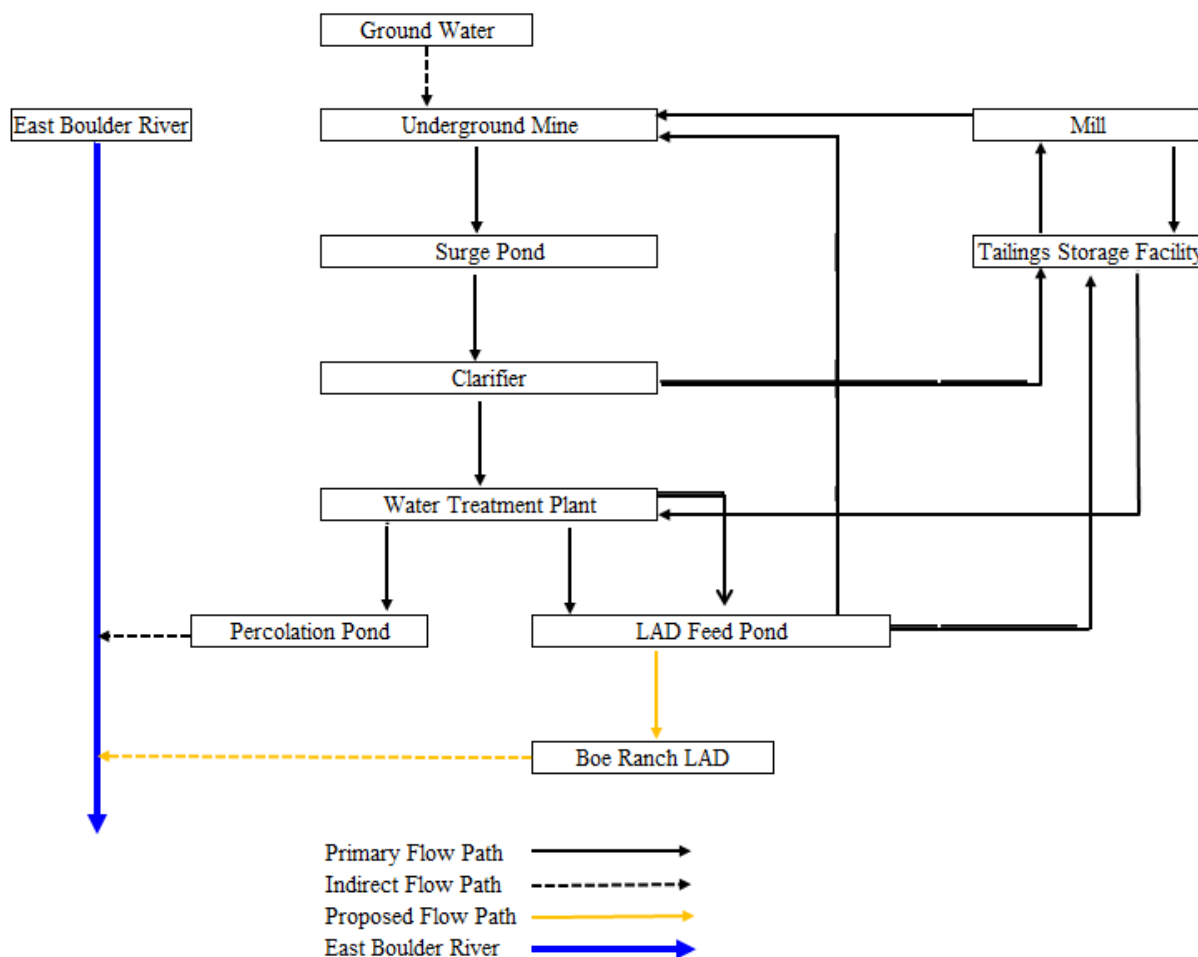

Figure 18: Flow Scenario 1

2.3.2. Flow Scenario 2

Flow scenario 2 focused on increasing surge capacity as well as increase potential solid-liquid separation, to reduce loading on the clarifier (Figure 19). The flow path of effluent mine water was changed to flow directly to the TSF instead of the surge pond. Water treatment plant influent water would be pulled from the TSF subdrain, forcing the water to travel through the TSF sediment in attempt to settle out and capture more suspended solids. This flow scenario could reduce loading on the clarifier, possibly resulting in increased water treatment plant

efficiencies and reduced total nitrogen discharge. A flow diagram for flow scenario 2 is shown in Figure 19.

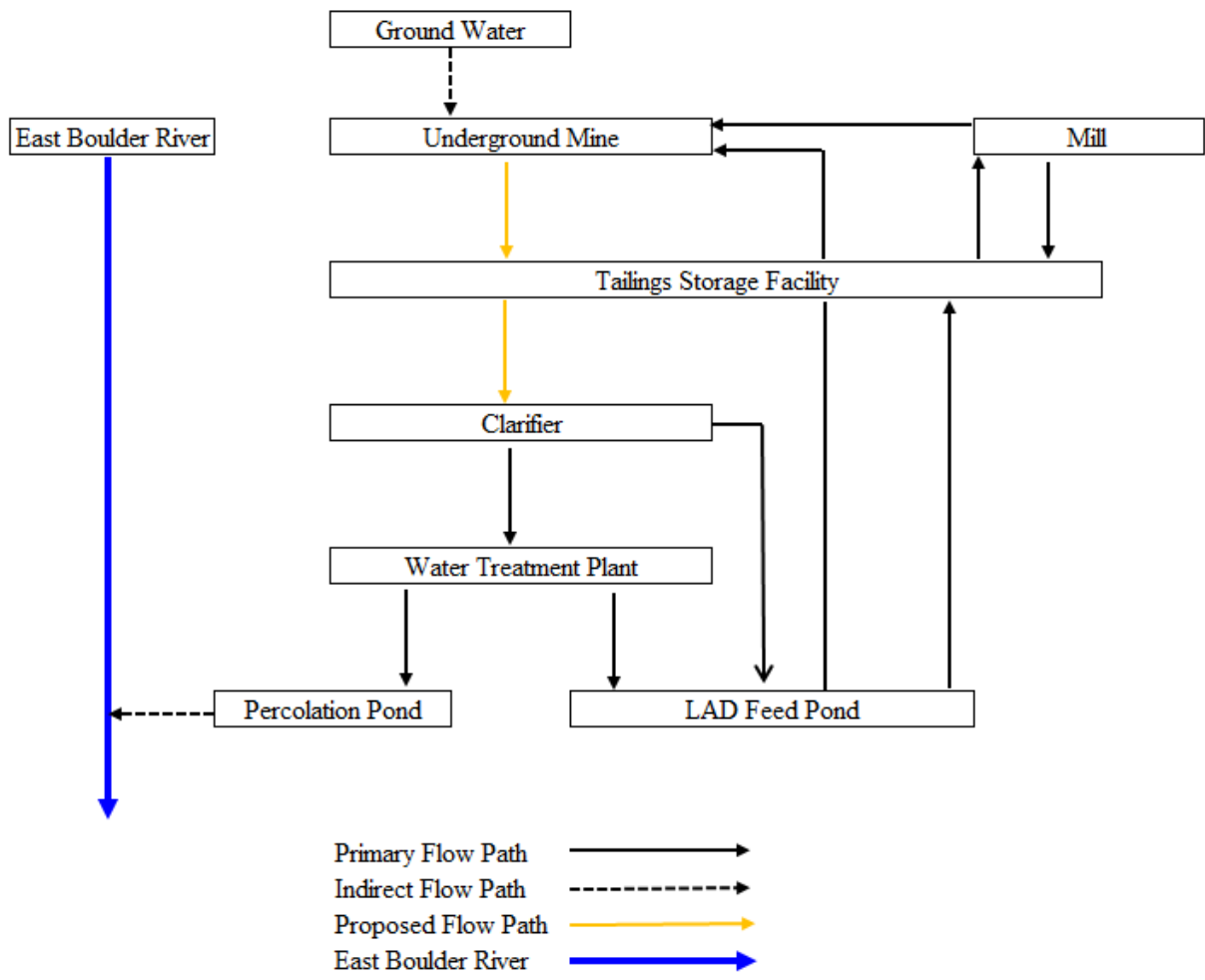

Figure 19: Flow Scenario 2

2.3.3. Flow Scenario 3

The last proposed flow scenario is flow scenario 3. Flow scenario 3 looks at the impact to the water balance from the incorporation of both flow scenarios 1 and 2. Figure 20 shows the flow diagram for flow scenario 3.

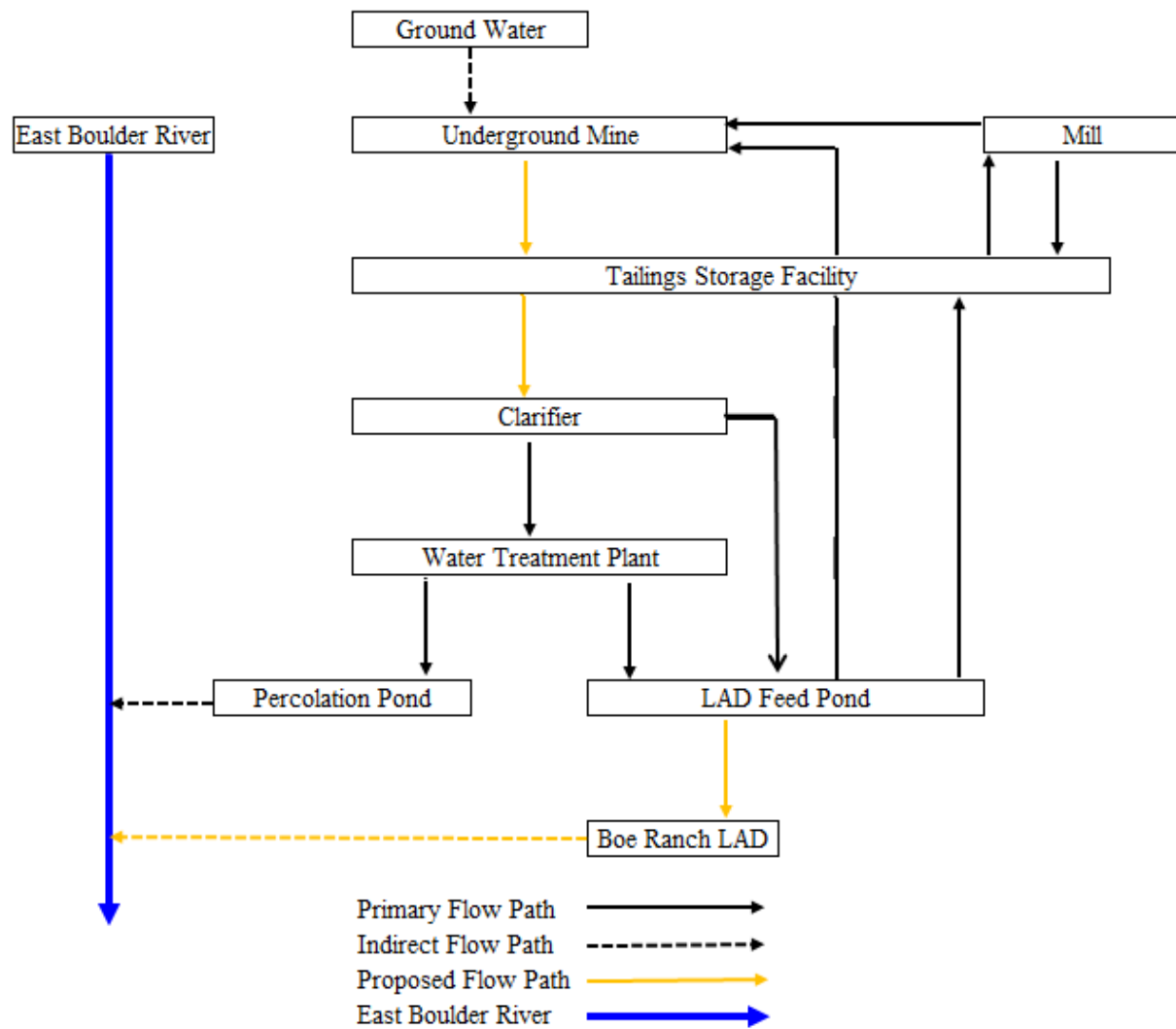

Figure 20: Flow Scenario 3

3. Results and Discussion

3.1. Base Flow

The 2015 base flow water balance is shown below in Figure 21. Since the water balances are performed on a yearly average basis, the results may be different when compared to instantaneous operational flows.

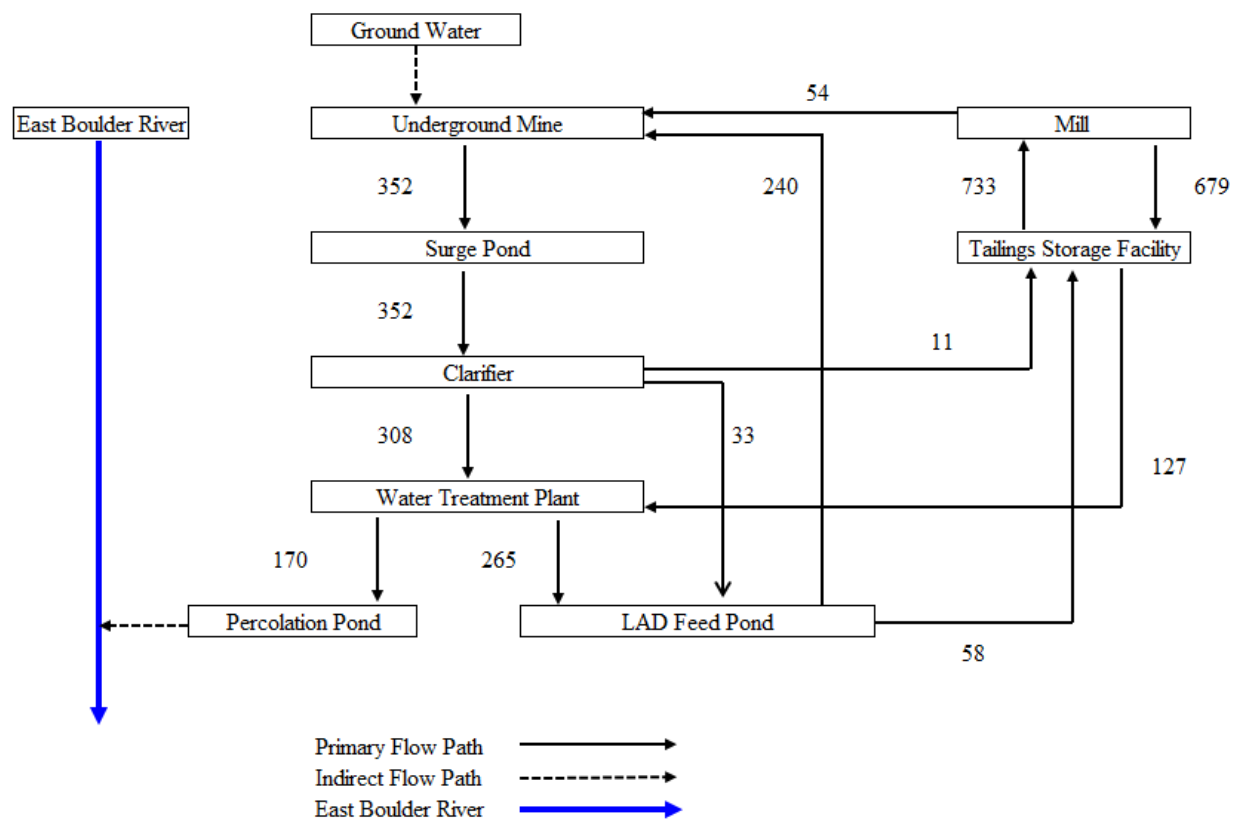

Figure 21: 2015 Base Flow Water Balance

Riser water total flow was calculated to be 41,469,996 gallons with an average flow rate of 60 gpm. Total mine water was calculated to be 153,785,383 with an average flow rate of 292 gpm. Mine water will combine with riser water to create the mine effluent average flow rate of 352 gpm. Total mine effluent was calculated to be 195,255,379 gallons.

Total discharge to the percolation pond for 2015 was calculated to be 110,465,989 gallons with an average discharge flow rate of 170 gpm. Total recycled mine water was calculated to be 156,612,510 gallons with an average flow rate of 265 gpm.

Total inputs to the underground mine were found to be 362,804,494 gallons, with outputs from the mine totaling 195,255,379. From Equation 4 total accumulations for the underground is 167,549,115. The percentage of backfill slurry that dewateres to the low point sump is unknown. There is a strong possibility that the backfill material is entraining and trapping a large portion of the water sent underground. If the backfill slurry term is taken out of Equation 4, accumulation is shown to be 2,827,127 gallons. Because the underground system has such large volumes of recycled water, the accumulation term is difficult to accurately quantify. If Equation 4 is adapted to use gallons per minute instead of total gallons, the total inputs to the underground mine is 354 gpm and the output for the mine is 352 gpm, resulting in a gain of 2 gpm. More information is needed to accurately compute underground accumulation.

Total precipitation for 2015 was calculated to be 24.6 inches. Applying this over the area of the TSF (2,236,019 square feet), the resulting input from precipitation to the water balance was calculated to be 34,287,115 gallons. Figure 22 shows historical precipitation from the SNOTEL site. The average annual accumulation from 2008 to 2017 was shown to be 27.8 inches. The 2015 year is 3.2 inches below the average for 2008 to 2017.

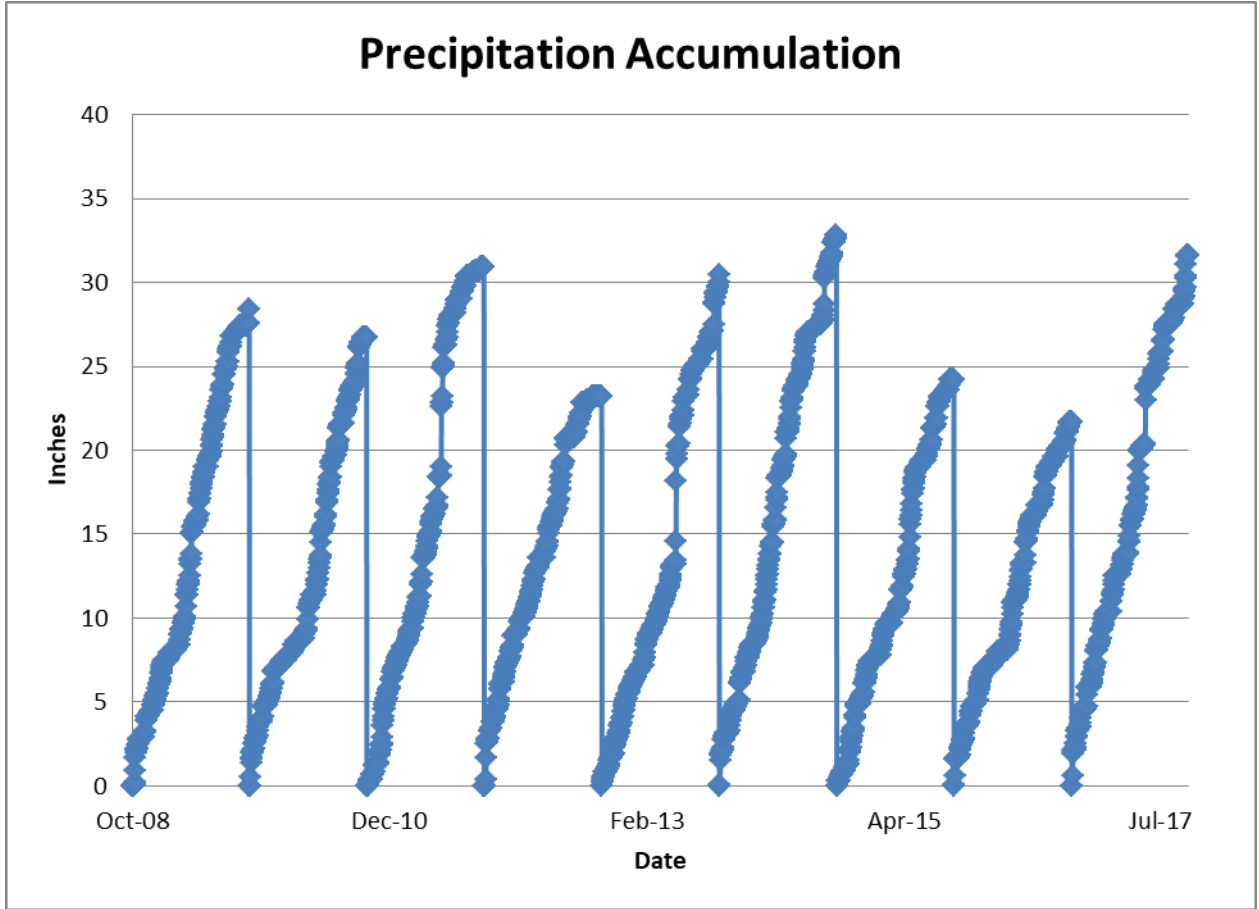

Figure 22: NRCS SNOTEL Historical Precipitation Accumulation

Figure 23 shows historical USGS discharge for the Boulder River. The East Boulder River that runs adjacent to the mine site does not have a USGS flow monitoring station. The East Boulder River does however flow into the Boulder River. Figure 23 further illustrates that the 2015 was a rather average year for precipitation and runoff.

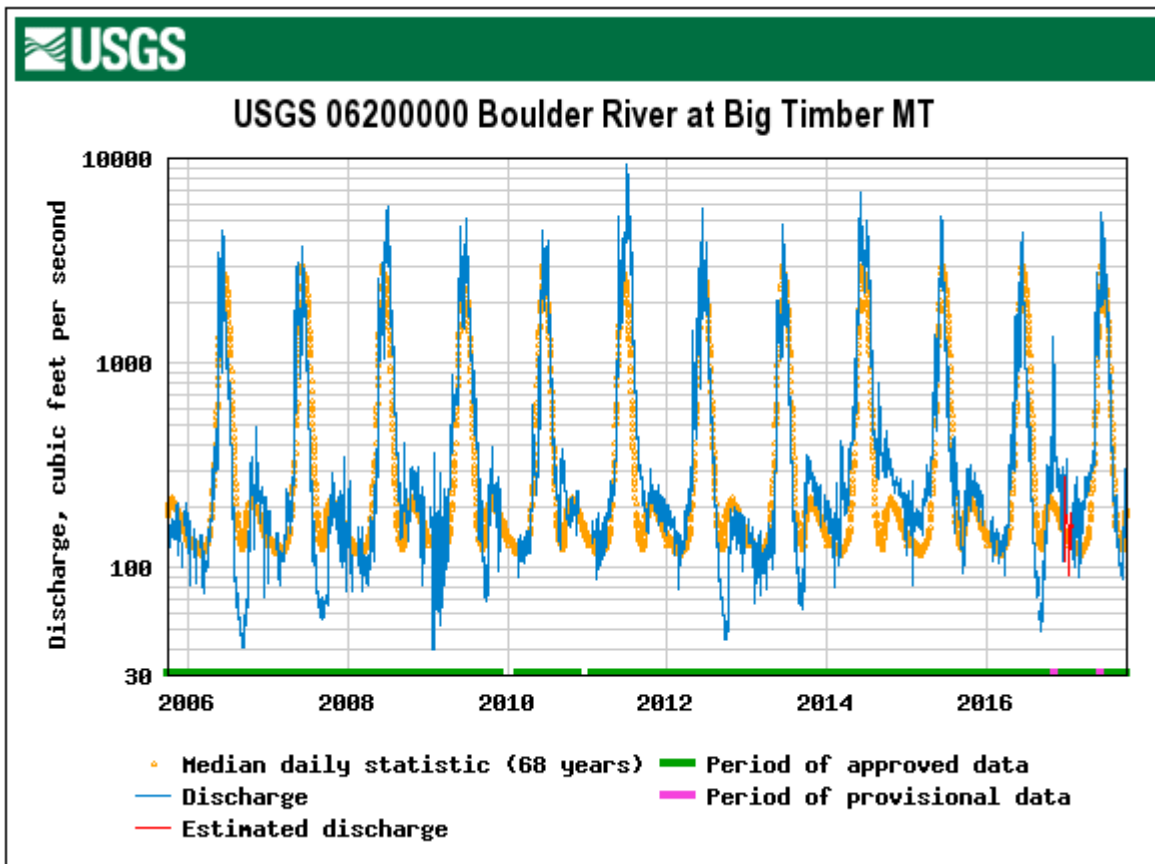

Figure 23: USGS Historical Boulder River Discharge

From the Detailed Design for Stage 6 TSF Expansion Report performed by Knight Piésold Consulting, annual evaporation was shown to be 34,501,640 gallons.

The total input to the TSF was 427,435,915 gallons. The total outflows for the TSF was 486,517,640 gallons. Using Equation 5, the total accumulation for the TSF under base flow was calculated to be a loss of 59,081,725 gallons. Under current operations, the TSF is being dewatered. The goal of operations is to reduce the amount of entrained water within the TSF. The total change in storage term from Equation 5 supports the goal of operations.

From Equation 3, total inputs to the mine site for 2015 were 75,757,111 gallons. Total outputs for the mine were 144,967,629 gallons, resulting in total change in storage for the entire site was calculated to be a loss of 69,210,518 gallons.

Water quality data for base flow conditions is presented in Table IV.

Table IV: Base Flow WTP Average TIN

Month	Influent (mg/L)	Effluent (mg/L)	%Removal
Jan	29.5	4.5	84.8
Feb	28.7	4.0	86.0
Mar	29.7	2.5	91.6
Apr	30.2	6.1	79.9
May	28.0	0.5	98.2
Jun	21.2	5.8	72.7
Jul	29.3	2.3	92.0
Aug	21.7	8.5	60.7
Sept	20.4	5.6	72.8
Oct	28.7	12.5	56.5
Nov	33.4	3.5	89.5
Dec	30.9	13.4	56.6
Annual	27.6	5.8	78.4

The yearly average WTP influent total inorganic nitrogen (TIN) concentration is 27.6 mg/L with an effluent concentration of 5.8 mg/L. The yearly average TIN removed was 78.4%.

Effluent TIN concentration of 5.8 mg/L is below the MPDES limit of 8.9 mg/L. Table V shows the yearly loading on the water treatment plant under base flow conditions. The yearly reduction of total nitrogen from the water treatment plant was calculated to be 48,337 lb.

Table V: WTP Base Flow Total Nitrogen Loading

	Flow Rate (gpm)	Concentration (mg/L)	Load (lb/year)
In	435	27.6	52,662
Out	170	5.8	4,325

3.2. Flow Scenario 1

Flow scenario 1 water balance is show in Figure 24.

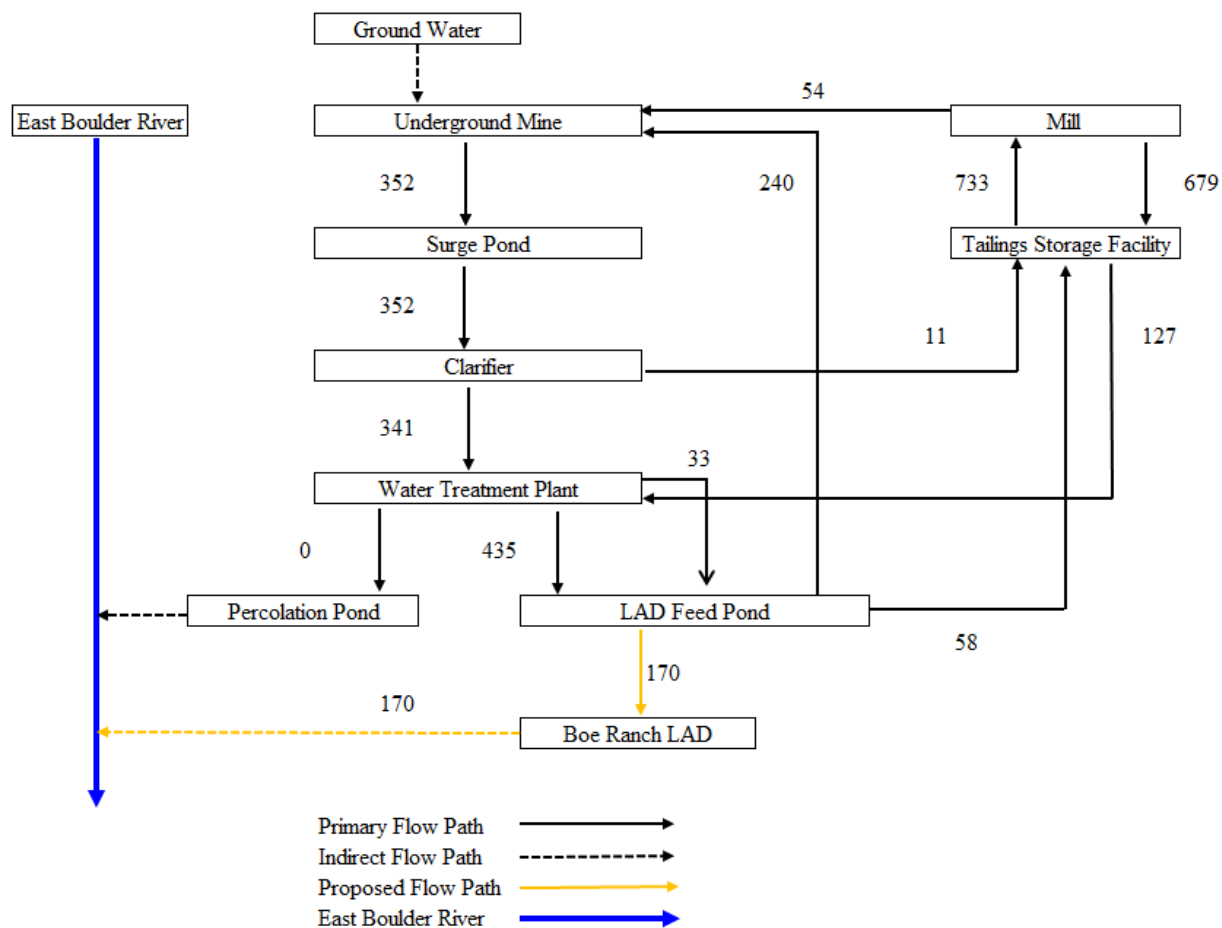

Figure 24: Flow Scenario 1 Water Balance

By shifting the discharge point from the percolation pond to the Boe Ranch LAD, the rest of the water balance remains relatively unchanged in comparison to base flow water balance. Base flow rates were used to set key flow rates in the proposed flow scenarios, such as Mill process feed water and underground mine water effluent. Water accumulation in the TSF and underground mine for base flow conditions and flow scenario 1 are the same. Site wide accumulation does not change from base flow conditions to flow scenario 1. Table VI shows total nitrogen load discharged by the LAD system for flow scenario 1.

Table VI: Flow Scenario 1 LAD Total Nitrogen Load

Flow Rate (gpm)	Concentration (mg/L)	Load (lb/year)	Load (lb/day)	Load (lb/acre)
170	5.8	4,325	11.85	2.70

For agricultural application of nitrogen for fertilizer on pasture or grazing fields, nitrogen is typically applied at 80 lb/acre (Brummer, 2009). Under flow scenario 1, LAD application of nitrogen at 2.70 lb/acre is much less than the recommended 80 lb/acre. Table VII shows the maximum nitrogen load that could be discharged under the mine's MPEDS permit.

Table VII: Max Total Nitrogen Loads under MPEDS Permit

Load (lb/day)	Load (lb/year)	Load (lb/acre)
30	10,950	6.8

At maximum nitrogen discharge, the LAD will apply 6.8 lb/acre of total nitrogen, which is still below the recommended 80 lb/acre for nitrogen fertilizer.

3.3. Flow Scenario 2

The water balance for flow scenario 2 can be seen in Figure 25.

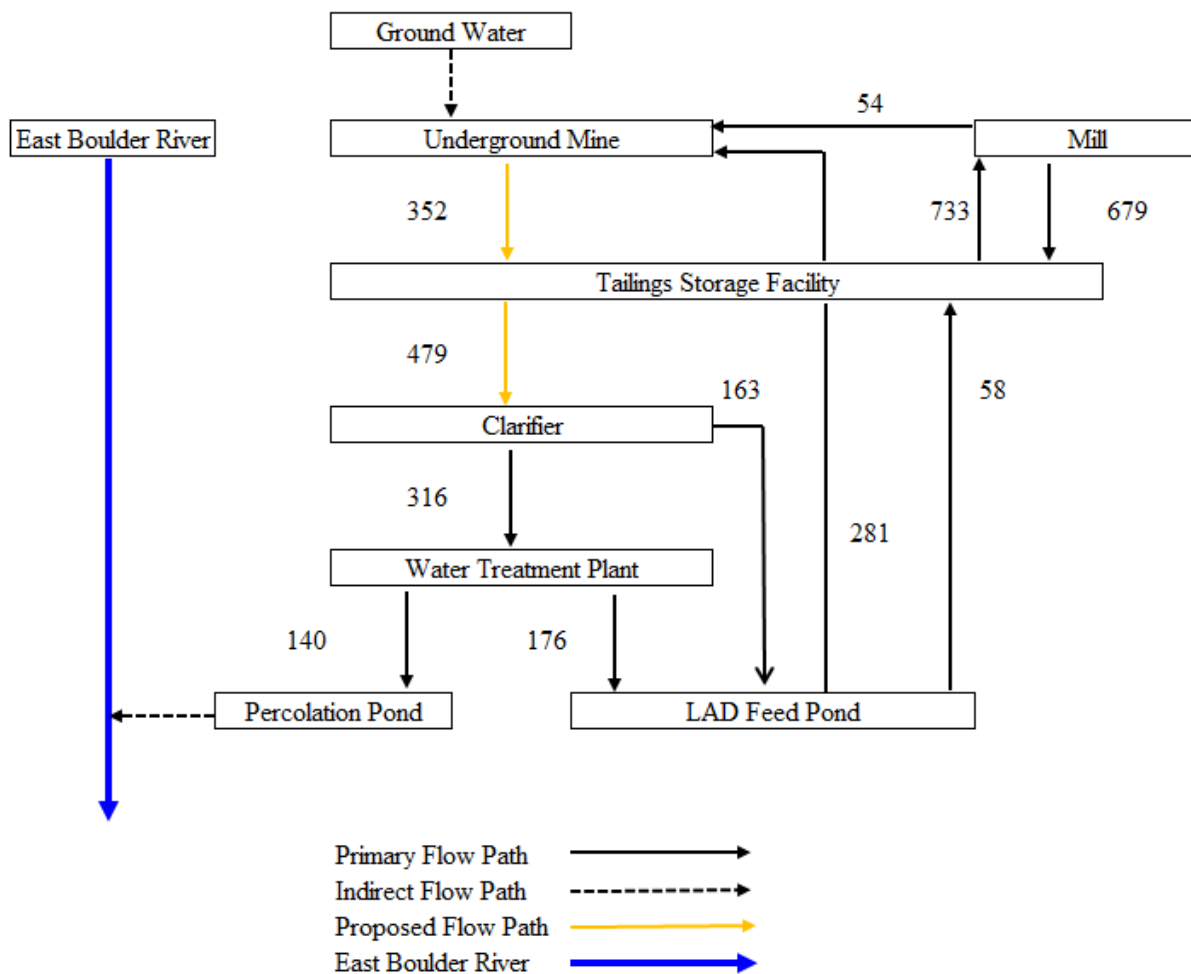

Figure 25: Flow Scenario 2 Water Balance

Flow scenario 2 results in greatly increased surge capacity for the WTP. The surge pond in base flow conditions has a volume of 329,000 gallons whereas the TSF has a surge capacity of 148,000,000 gallons. The increase in surge capacity allows the WTP to have a more constant and steadier influent water conditions. The clarifier receives greater flow rate but potentially improved water quality such as reduced nitrogen concentration. More sampling and testing is required to support this claim.

Recycled mine water shows an increase of 41 gpm when compared to flow scenario 1. As the mine expands, the use and number of underground mine equipment will also increase. The

increase in recycled mine water was done primarily to account for future development of the underground.

TSF accumulation showed different results under flow scenario 2 in comparison to base flow and flow scenario 1. Adapting Equation 5, the total input under flow scenario 2 to the TSF was 575,806,515 gallons. The total outflows for the TSF was 671,528,840 gallons. The total accumulation for the TSF under flow scenario 2 was calculated to be a loss of 95,722,325 gallons. This shows a 62% increase in TSF dewatering between flow scenario 2 and base flow conditions, thus potentially reducing entrained water in the TSF. This value is within reason as future operations predict the need to dewater the TSF.

Average annual TSF total nitrogen sample data from 2015 is shown in Table VIII.

Table VIII: Average TSF Total Nitrogen Samples

Sample	Total Nitrogen (mg/L)	% Difference
TSF Pond	338.2	96.5
TSF Subdrain	11.5	

The average annual difference in total nitrogen for a sample collected from the top of the TSF pond compared to a sample collected at the TSF subdrain effluent shows a 96.5% difference in total nitrogen. This difference in nitrogen concentration is believed to be from the filtering that occurs from flowing through the layers of sediment within the TSF, with more sampling needed to determine the exact cause.

The water treatment plant annual average total nitrogen influent concentration could potentially be lowered from 27.6 mg/L to 11.5 mg/L when comparing base flow conditions to

flow scenario 2. Table IX shows the yearly loading on the water treatment plant for flow scenario 2. The yearly reduction of total nitrogen from the water treatment plant was calculated to be 14,277 lb. When compared to base flow conditions, flow scenario 2 shows a 34,060 lb reduction in nitrogen loading on the water treatment plant.

Table IX: Flow Scenario 2 WTP Total Nitrogen Loading

	Flow Rate (gpm)	Concentration (mg/L)	Load (lb/year)
In	316	11.5	15,940
Out	140	2.46	1,511

Recycled mine water showed an increase in flow, allowing for more water to be used by underground equipment. As the mine expands, the use and number of underground equipment also increases, thus increasing the demand for recycled mine water. The exact recycled mine water flow rate can be adjusted to meet the needs of future underground operations.

From Equation 3, total inputs to the mine site for flow scenario 3 were 75,757,111 gallons. Total outputs for the mine were 123,853,640 gallons, resulting in total change in storage for the entire site was calculated to be a loss of 48,099,529 gallons. Discharge decreased from 110,465,989 gallons to 89,352,000 gallons, between base flow and flow scenario 2, thus ultimately reducing total outputs from the system. Precipitation, riser water, and evaporation terms for flow scenario 2 were unchanged from base flow conditions.

Underground accumulation was not calculated because of the uncertainties associated with underground accumulation during base flow conditions.

3.4. Flow Scenario 3

Flow scenario 3 water balance is shown in Figure 26.

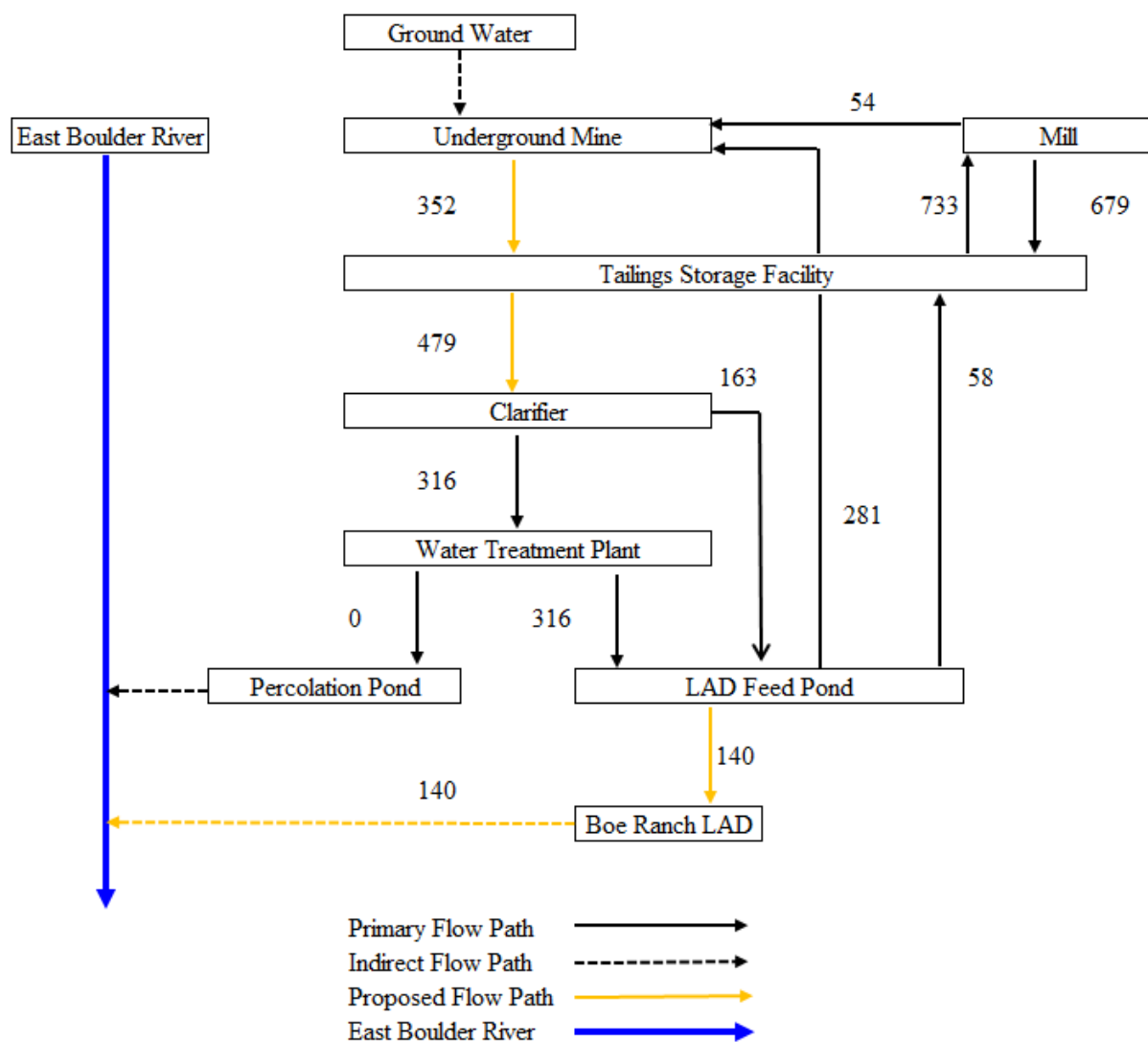

Figure 26: Flow Scenario 3 Water Balance

Flow scenario 3 shows only a slight difference from flow scenario 2, with again, the shift in discharge point from the percolation pond to the Boe Ranch LAD. By shifting the discharge point from the percolation pond to the Boe Ranch LAD, the rest of the water balance remains

relatively unchanged from flow scenario 2 to flow scenario conditions. Site wide accumulation and TSF accumulation does not change between flow scenario 2 and flow scenario 3.

Table X shows total nitrogen load discharged by the LAD system for flow scenario 3.

Table X: Flow Scenario 3 LAD Total Nitrogen Load

Flow Rate (gpm)	Concentration (mg/L)	Load (lb/year)	Load (lb/day)	Load (lb/acre)
140	2.46	1,511	4.14	0.94

3.5. Comparison

Flow scenario 1 improves water management by diversifying discharge options. Flow scenario 1 shows minimal change to the water balance from base flow conditions with the incorporation of the LAD. The LAD improves water use rather than improving discharge water quality.

Flow scenario 2 focuses on improving operating conditions. Using the TSF as a surge pond increases surge capacity, as well as stabilize water quality. High nitrogen slugs from the underground will be diluted and stabilized within the large volume of the TSF. More sampling is needed to verify these potential results. Flow scenario 2 shows greater dewatering of the TSF, an increase of 36,640,600 gallons of water. Flow scenario 2 also shows less site wide water loss with 21,110,989 gallons of water retained when compared to base flow, resulting in lower discharge flow rate and increased mine water recycle flows. Total nitrogen discharge was also reduced by 2,814 lb.

Flow scenario 3 shows the combined improved water management method from flow scenario 1, and potential improved operating conditions of flow scenario 2. Site wide

accumulation and TSF accumulation was the same as flow scenario 2. Flow scenario 3 shows LAD application of nitrogen at 0.94 lb/acre, an overall reduction in total nitrogen of 2,814 total pounds per year when compared to flow scenario 1.

2015 was a slightly lower than average water year. The inputs to this system are precipitation and riser water, both of which are effected by dry or wet water years. Under wet year conditions, both riser water and precipitation volumes will increase, causing greater discharge volumes to prevent overflow within the system. There is a potential for nitrogen concentrations to decrease under wet year conditions due to the increase in water volume. Dry years will result in an increase of recycled mine water and a decrease in water discharge. Water can be pulled from the East Boulder River to make up deficit water conditions. As the underground mine expands, the volume of riser water is expected to increase and dry operation conditions are not expected (Knight Piésold Consulting, 2017). There is a potential for nitrogen concentrations to increase under dry operating conditions due to the decrease in water volume.

Flow scenario 1 is recommended for construction based off of the developed quantitative flow diagrams and water balance. Flow scenario 2 and flow scenario 3 require additional sampling and feasibility study to fully determine the effects of using the TSF as surge pond for the water treatment plant.

4. Summary

Base flow rates as well as proposed water flow rates under different flow scenarios were presented in a quantitative flow diagram. Flow scenarios can be manipulated to meet different needs of operations. By changing the base flow direction and incorporating the TSF as a surge basin, there is a potential for nitrogen reduction as well as greater dewatering of the entrained water within the TSF could be accomplished. Water treatment plant surge capacity was greatly increased under flow scenario 2 and flow scenario 3. Preliminary data showed there is a possible reduction in total nitrogen as water flows into the TSF and exits through the subdrain. More data is required to decisively conclude the effect on nitrogen concentration.

The development of flow scenario 1 is ultimately recommended. Flow scenario one allows for diversified water discharge options with minimal impact to the water balance. The incorporation of the LAD to base flow conditions allows for discharged water to be used in a beneficial manner as a potential pasture fertilizer.

Large quantities of recycled mine water created uncertainty within the water balance. Due to the method in which water flows are totalized, the possibility of counting water multiple times within the system is possible. Areas within the water balance such as Mill and Concentrator and underground operations required additional water monitoring and tracking to produce more accurate results.

5. Recommendations

The uncertainties identified within water balance require further investigation. In order to create a more certain water balance, the following actions are recommended.

- Improve flow monitoring database and tracking system to incorporate the entire mine site, not just focused on the water treatment plant and discharge flows
- Increase the number of flow monitoring locations, especially in the mill and concentrator as well as underground operations
- Improved tracking and monitoring of the Mill water flows
- Conduct sampling of the TSF aimed at understanding the interaction of the water within the impoundment
- Conduct more consistent sampling of parameters such as total nitrogen and TSS on the TSF
- Conduct further feasibility study on the TSF and possible use of the TSF as solid-liquid separator treatment process

6. References Cited

- Adams, E. A., Boateng, G. O., Amoyaw, J. A., Contents, T. O. F., Profileinformation, C., Statement, M., ... WRC. (1974). *Methods for water balance computations. The UNESCO Press*. Paris. <https://doi.org/10.1017/CBO9781107415324.004>
- Brochu, S. (2010). *Assessment of ANFO on the Environment*.
- Brummer, J. (2009). Does It Pay to Fertilize Grass Hayfields with Nitrogen? In *Idaho Alfalfa and Forage Conference* (pp. 11–13).
- Chambers, D. (2014). *Land Application Disposal (LAD) Guidelines*. Bozeman, MT.
- Consulting, K. P. (2017). *APPENDIX I WATER BALANCE*.
- Davis, M., Engineer, G., Alexieva, T., & Zurakowski, Z. (2013). Development of a Mine Site-Wide Water Balance □ Mine Water Management □ Case Studies.
- Engineering, W. (2017). *Water treatment study*.
- Greyn, C. (2015). *NITROGEN REMOVAL IN A BIOLOGICAL WASTEWATER TREATMENT PLANT*. Montana Tech of the Univeristy of Montana.
- ICMM. (2012). *Water management in mining : a selection of case studies*. <https://doi.org/978-0-9559983-7-9>
- McPhail, G. (2005). Getting the Water Balance Right. *Tailings & Paste Management and Decommissioning*, 1–11, Section14.
- MDEQ. (2015). *Minor MPDES Permit: Stillwater Mining Company East Boulder*. Retrieved from <http://deq.mt.gov/Water/WPB/mpdes/majorpermits>
- Mining, I. (2011). Stillwater runs deep. *International Mining*, (September).
- Prosser, I., Wolf, L., & Littleboy, A. (2011). Water in mining and industry. In *Water: Science and Solutions for Australia* (pp. 135–146). https://doi.org/http://dx.doi.org/10.1071/9780643103283_Chapter_10
- SMC. (2002). *Water Managment Plan Appendix K: Boe Ranch LAD Alternative*.
- SMC. (2016). *East Boulder Mine Water Resources Monitoring Plan*.
- Wade, L. (2014). *A Probabilistic Water Balance*. Montana Tech of the University of Montana.
- Wilburn, D. R., & Bleiwas, D. I. (2004). *Platinum-Group Metals: World Supply and Demand. U.S. Geological Survey Open-File Report*.

SIGNATURE PAGE

This is to certify that the thesis prepared by Kelly Hertel entitled "Site Wide Water Balance of The East Boulder Mine" has been examined and approved for acceptance by the Department of Environmental Engineering, Montana Tech of The University of Montana, on this 23th day of April, 2018.



Daqian Jiang, PhD, Assistant Professor
Department of Environmental Engineering
Chair, Examination Committee

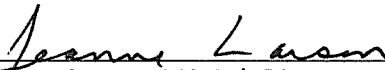

Jeanne Larson, MS, Lab Director and Instructor
Department of Environmental Engineering
Member, Examination Committee



Glenn Shaw, PhD, Associate Professor
Department of Geological Engineering
Member, Examination Committee