

3-2018

Drafting in Self-Timed Circuits

Christopher Cowan

Portland State University, maddogclc@gmail.com

Let us know how access to this document benefits you.

Follow this and additional works at: https://pdxscholar.library.pdx.edu/ece_phd_day

 Part of the [Controls and Control Theory Commons](#), and the [Electrical and Electronics Commons](#)

Citation Details

Cowan, Christopher, "Drafting in Self-Timed Circuits" (2018). *Electrical & Computer Engineering PhD Day*. 3.
https://pdxscholar.library.pdx.edu/ece_phd_day/3

This Poster is brought to you for free and open access. It has been accepted for inclusion in Electrical & Computer Engineering PhD Day by an authorized administrator of PDXScholar. For more information, please contact pdxscholar@pdx.edu.

What is Drafting?

- Handshake pulses travel around a ring of stages.
- Intervals between the pulses change with time.
- The green interval lengthens, while the others shorten.
- This is called "drafting", like bicycle riders.
- If the interval is data, drafting corrupts the data.

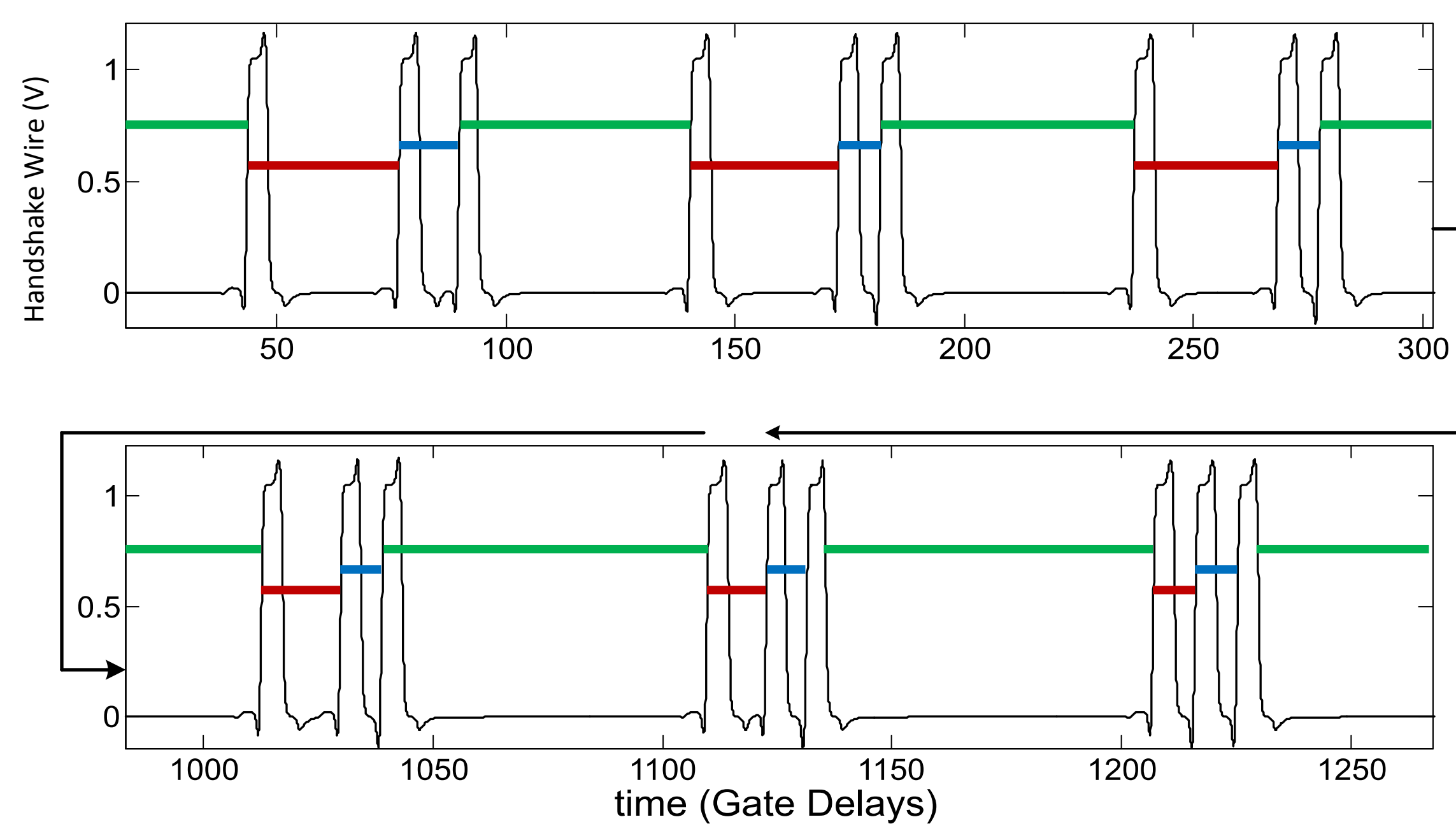

The Behavior of the Internal Node in the NOR Gate Causes Drafting

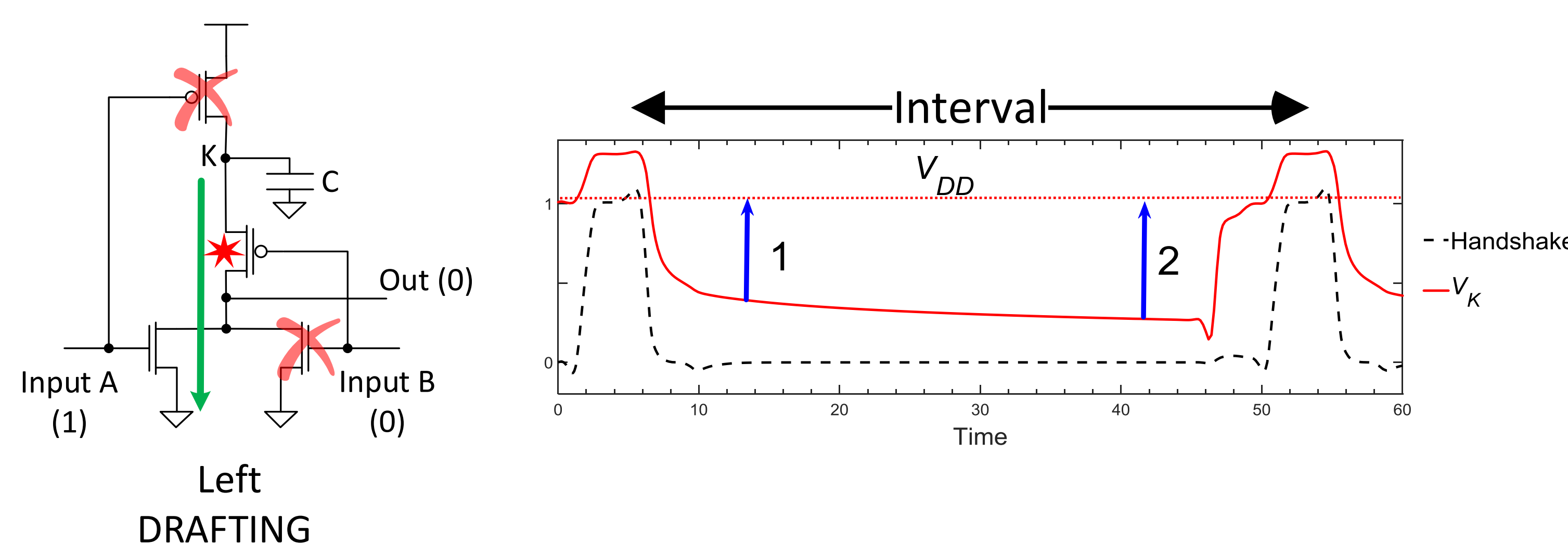

- Node K discharges during the interval via a diode connected PMOS. *
- As V_K decays it takes longer to charge it back to V_{DD} .
- Longer intervals (2) need longer charge time than shorter intervals (1).
- Longer charge = longer propagation delay through the NOR and drafting.

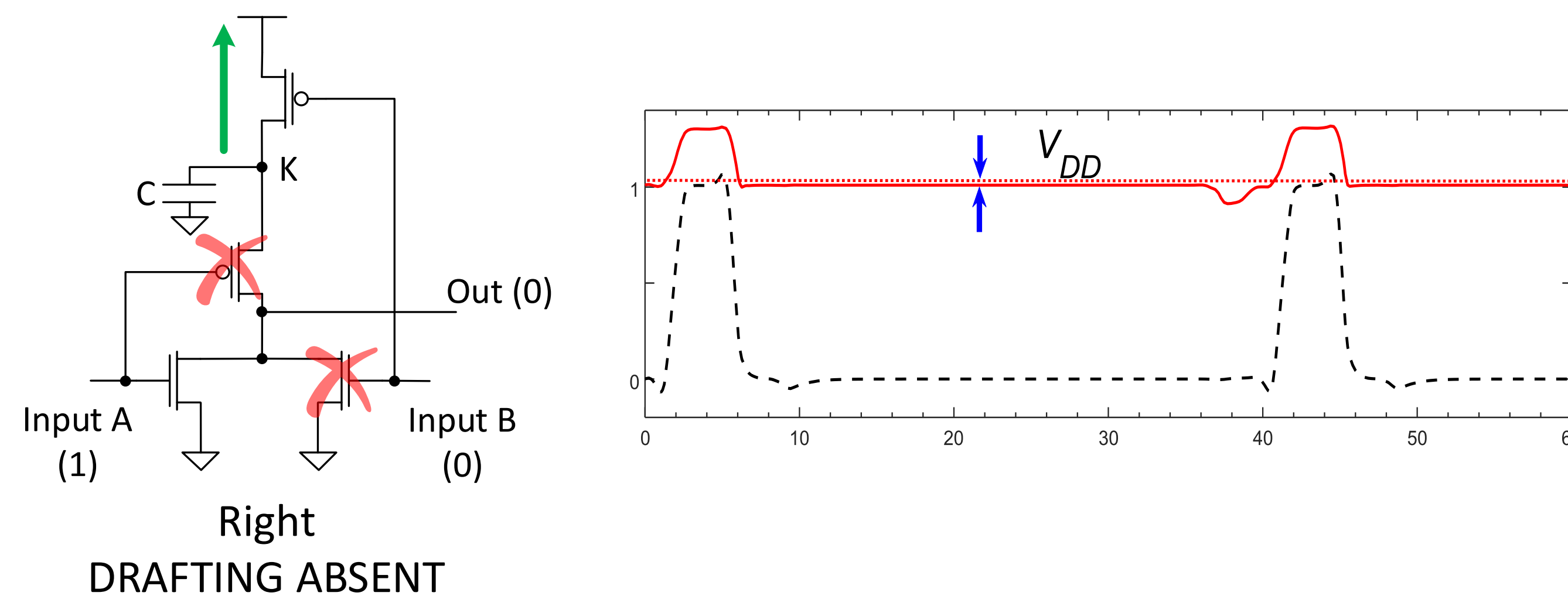

- In the NOR Right configuration V_K stays constant at V_{DD} .
- Propagation time through NOR is constant and drafting is absent.

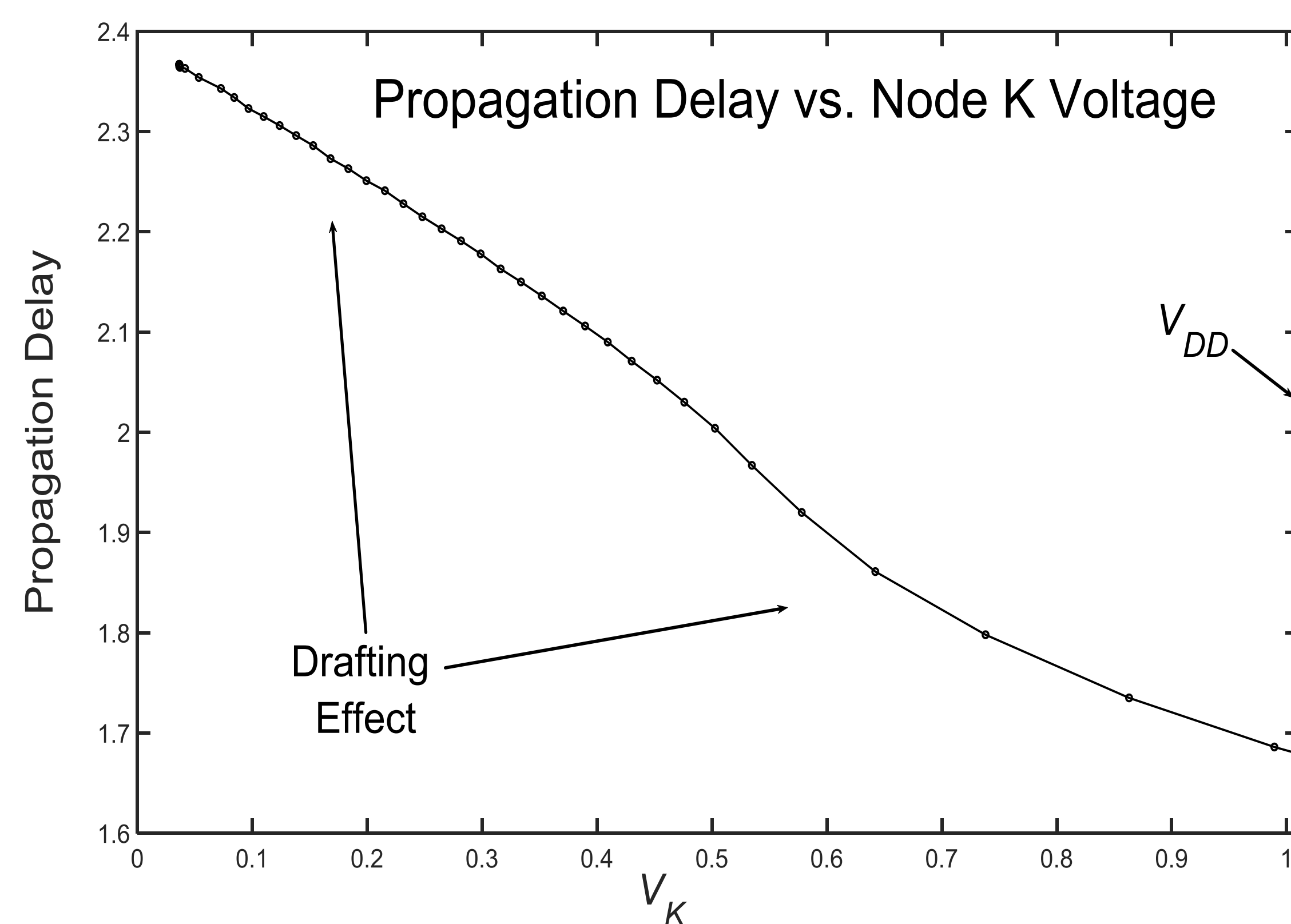

- Propagation delay changes with interval size by the decay of V_K .
- The varying propagation delay creates drafting.
- Short intervals shorten faster than longer intervals.
- In a ring FIFO this results in one long interval and the others short.

Circuit to Control Drafting

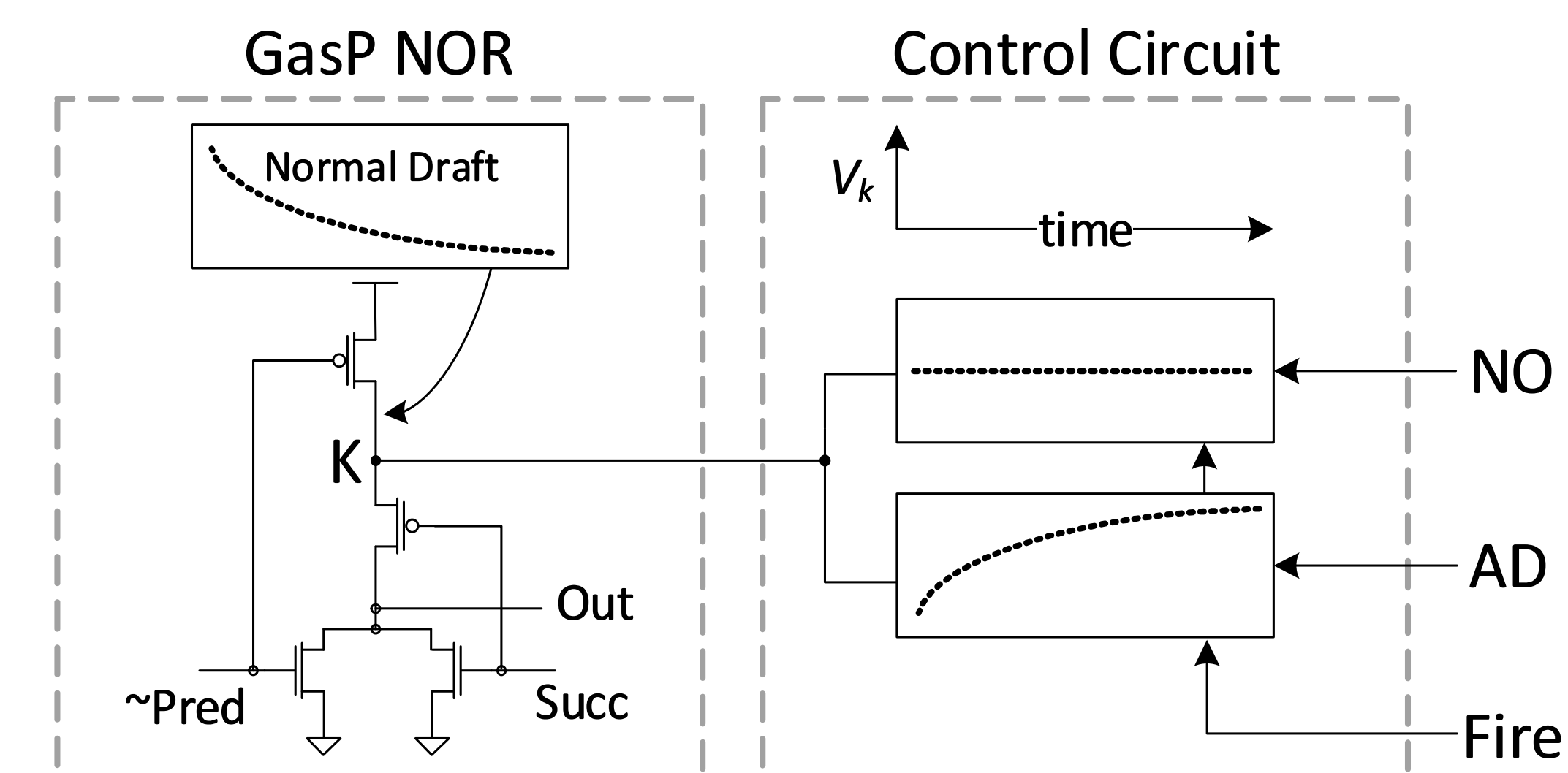

- For drafting, allow the K node to decay normally.
- For NO drafting, keep the K node constant.
- For anti-drafting (AD), force a rising profile at K.
- AD causes intervals to become equal rather than shrinking.

Control Circuit Results

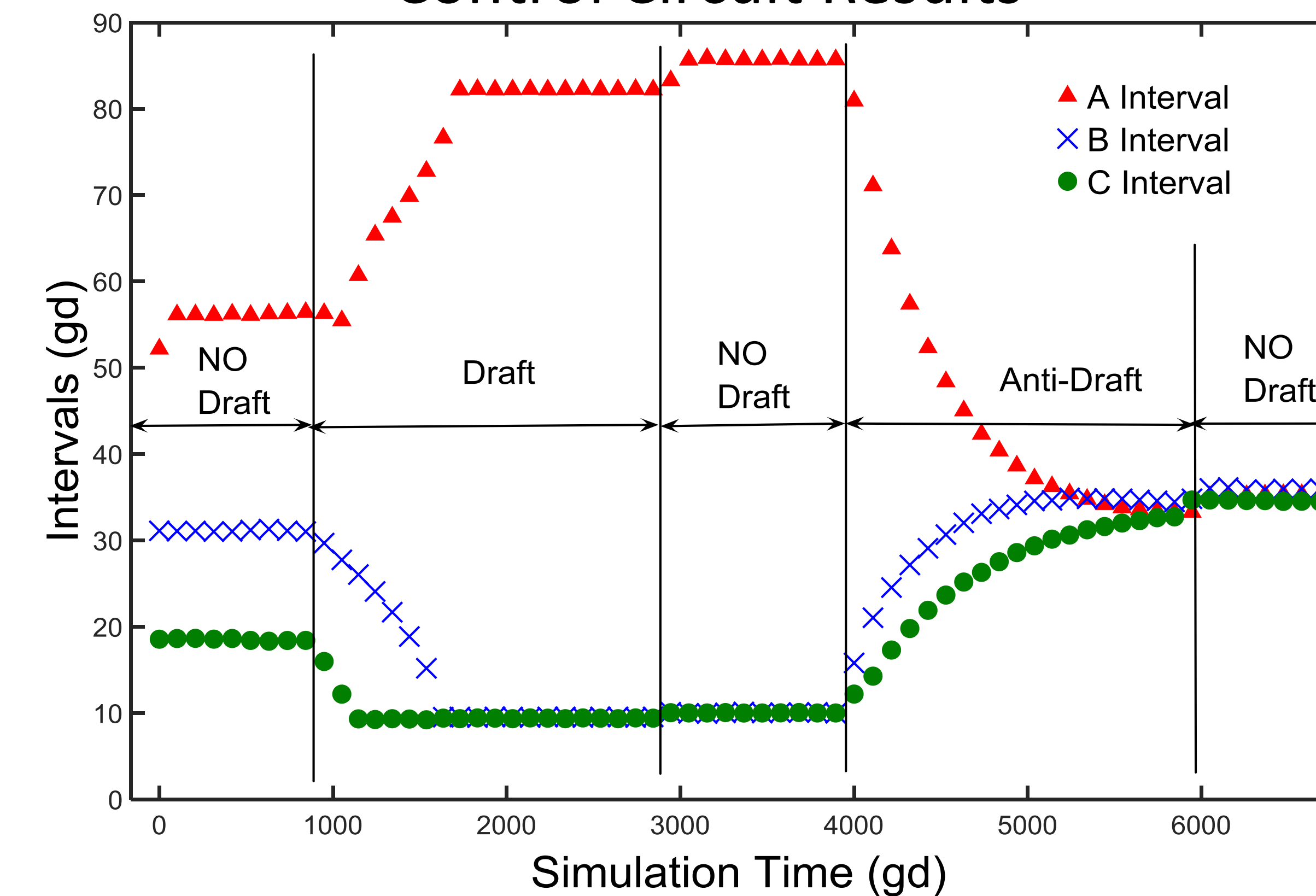

- Three intervals are measured in nominal gate delays during simulation.
- During NO Draft control, the intervals do not change.
- During Draft control, two intervals become minimal and the third becomes maximum.
- During Anti-Drafting control, all intervals become equal.

Test FIFO for Drafting

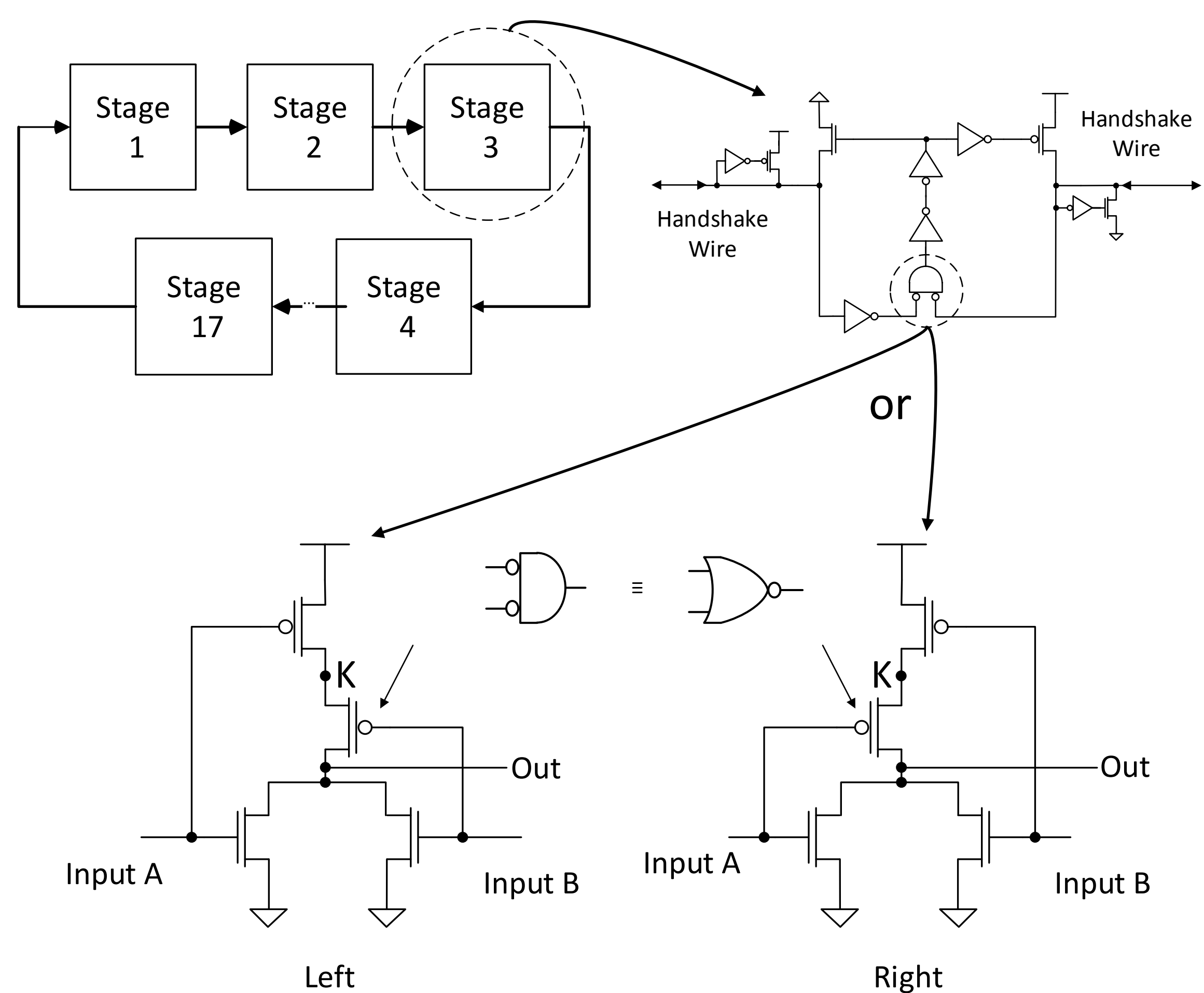

- The test circuit is a 17 stage FIFO.
- Three circulating handshake pulses and three intervals.
- The handshake decision gate is a NOR.
- The NOR decision gate can be in a Left or a Right configuration with the same logical function.

References

- [1] J. C. Ebergen, S. Fairbanks, and I. E. Sutherland, "Predicting performance of micropipelines using Charlie diagrams," in *Fourth International Symposium on Advanced Research in Asynchronous Circuits and Systems*. IEEE, 1998, Conference Proceedings, pp. 238–246.
- [2] S. M. Fairbanks, "High precision timing using self-timed circuits," Ph.D. dissertation, University of Cambridge, 2005.
- [3] A. Winstanley and M. Greenstreet, *Temporal properties of self-timed rings*. Springer, 2001.
- [4] A. J. Winstanley, A. Garivier, and M. R. Greenstreet, "An event spacing experiment," in *Eighth IEEE International Symposium on Asynchronous Circuits and Systems (ASYNC)*. IEEE, 2002, Conference Proceedings, pp. 47–56.
- [5] V. Zebilis and C. P. Sotiriou, "Controlling event spacing in self-timed rings," in *11th IEEE International Symposium on Asynchronous Circuits and Systems (ASYNC)*. IEEE, 2005, Conference Proceedings, pp. 109–115.