

# A Domain-aware Framework for Integrated Model-based System Analysis and Design

Adrian Rumpold, Reinhard Pröll and Bernhard Bauer

*Institute for Software & Systems Engineering, University of Augsburg, Augsburg, Germany*

**Keywords:** Domain-specific Modeling, Model Transformation, Model-based Analysis.

**Abstract:** The increasing complexity of modern embedded systems demands advanced design and development methods. Incremental evolution of model-based engineering practice has led to heterogeneous tool environments without proper integration and exchange of design artifacts. These problems are especially prevalent in tightly regulated domains, where an independent assessment is required for newly developed products, e.g. in automotive or aviation systems. To address these shortcomings of current engineering practice, we propose a holistic model-based approach for the seamless design and development of an integrated system model. We describe an embedding of a variety of domain-specific modeling languages into a common general-purpose modeling language, in order to facilitate the integration between heterogeneous design artifacts. Based on this conceptual modeling approach, we introduce a framework for automated model-based analysis of integrated system models. A case study demonstrates the suitability of this modeling and analysis approach for the design of a safety-critical embedded system, a hypotheticalal gas heating burner.

## 1 INTRODUCTION

Embedded systems have continuously grown in both hardware and software complexity in recent years, with the advent of advanced functionality in many domains, such as automotive, aviation, and industrial automation.

System designers have attempted to cope with this increased complexity in two major ways: First, stricter engineering methodologies have been applied during the design and implementation of embedded systems, with a general trend towards model-based technologies. However, these model-based approaches have mostly been limited to the behavior and structure of the system under development, leaving aside non-functional and quality aspects.

Second, a very heterogeneous tool landscape has emerged to conquer the immense variety of non-functional aspects for such complex systems – covering legislative and regulatory issues, performance and timing requirements, and organizational factors (see chapter 4.1.2 of Sommerville (2011)).

Due to this asymmetry between partial adoption of model-based techniques and inconsistent tooling environments, establishing traceability

and consequent change management have emerged as two main challenges in systems engineering. The importance of these fields can be seen clearly in the context of safety-critical systems, where regulations require a careful management of development processes and artifacts with regard to consistent traceability throughout the product life cycle – for example the European IEC 61508-1:2010 (2010) functional safety standard.

The resulting need for careful manual review and management of traceability and consistency leads to sub-optimal process efficiency and potential negative impact on product quality.

### Problem Statement

The current state of the art in embedded systems engineering therefore can be improved through a more tightly integrated approach to model-based systems engineering.

Despite some effort towards model exchange between model-based engineering tools, e.g. through standardized interchange formats like XMI, seamless tool integration remains a fundamental challenge. The resulting need for manual process steps can lead to postponed quality-related design activities and consequently reduced overall product quality and

increased cost of quality defects discovered late in the development process.

Furthermore, textual artifacts, such as documentation required for safety certification, highlight the critical role of consistency between design models and the textual artifacts generated from them. Whereas common modeling tools allow for generation of technical documentation from system models, the generation of more complex textual artifacts exceeds their limited capabilities.

In order to overcome the identified weaknesses, we propose an approach which aims for a tight integration of all system modeling artifacts and shift towards (semi-)automated integrated architecture analyses.

Based on an extensible set of domain-specific modeling languages, which make up a solid foundation for a more suitable description of quality aspects, we aim for a co-evolution of functional and quality architectures of the system under development.

Through this strict model-based approach, the reuse of existing design methodologies is guaranteed, as long as their results can be formalized using an underlying metamodel. Consequently, this leads to a higher level of model consistency and improved capabilities for impact analysis.

The model-level integration of multiple domain-specific aspects additionally enables developers to make use of model-based document generation, which offers the flexibility mandated by the development of complex embedded systems.

We foresee that this integrated modeling approach will lead to increased product and documentation quality and can thus support the development of safety-critical and similarly regulated systems.

## Outline

Section 2 provides an overview of the fundamental modeling concepts in our approach and their roles during integrated system analysis and design. Starting with general-purpose modeling languages and their use inside our conceptual framework, we list a set of essential domain-specific views on the system and their embedding into the general-purpose language. Based on this definition of embedded domain-specific languages, we describe a model-based analysis framework in Section 3. In Section 4, we demonstrate the feasibility of our proposed approach using a realistic use case. There, we perform some exemplary design and analysis steps regarding the functional safety of a hypothetical gas heating burner. Section 5 discusses related work regarding the integration

of heterogeneous modeling tools, domain-specific modeling, and model-based analysis. Section 6 summarizes the key results presented in this paper and suggests possibilities for future work based on our current research.

## 2 A DOMAIN-AWARE APPROACH FOR SYSTEM MODELING

To overcome the previously identified problems, we have developed a concept designed to integrate legacy development and modeling technique with a new kind of domain-aware modeling approach and analysis framework. Based on the information embedded in an integrated system model, textual artifacts, which had to be maintained manually before, can now be generated automatically. In order to switch between these representations and generate documents, we make use of model-to-model (M2M) and model-to-text (M2T) transformations.

The high-level concepts and their internal relationships are illustrated in Figure 1 and will be elaborated in the following sections.

### 2.1 General Purpose Modeling Languages

Following our goal of easy application and seamless integration into state-of-the-art development processes, we have decided to embed all relevant data for the development process within a General Purpose Modeling Language (GPML), such as UML or Ecore. The major advantage of this decision is the reuse of modeling editor capabilities and the preexisting wide range of general purpose modeling tools.

These general-purpose languages serve a two-fold purpose: First, they provide a common modeling basis for all domain-specific aspect models, as described in the following section. Second, the GPML can itself be used to cover certain subsets of the domain-specific modeling disciplines, if their expressive power is sufficient for a specific project. We will see an example for this simplified domain aspect modeling in the case study in Section 4, where UML component diagrams and state machines are used to describe parts of the system architecture.

Our approach does not prescribe a certain GPML to be used for modeling the integrated system model. The only necessary requirement is the possibility to enhance the general-purpose language with metamodel extensions. In the case of UML

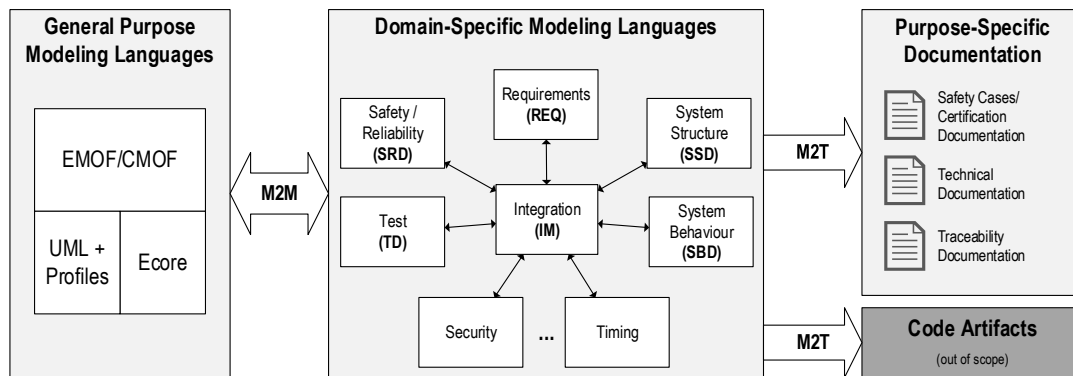

Figure 1: Conceptual overview of the architecture and analysis framework.

this is achieved by defining profiles that leverage the stereotype mechanism. Similarly, we can extend the expressive capabilities of modeling languages which are themselves specified as UML profiles, for example SysML. Within the widely popular Eclipse Modeling Framework (EMF), metamodel extensions can be easily defined due to the reflexivity of the Ecore modeling language, which itself is its own meta-model.

## 2.2 Domain-specific Modeling Languages

In order to accurately describe domain-specific aspects of the system under development, we embed them into the GPML mentioned above as *domain-specific modeling languages* (DSML). Our approach allows for any number of DSMLs to be used in conjunction with a general-purpose modeling tool to obtain an *integrated system model* (ISM) or *Omni model*.

These DSMLs preserve the separation of concerns, but enable developers to link information across domains in order to build up a holistic view of the system under development (SUD) and facilitate analyses based on domain-specific information.

In this section we briefly introduce some common domains and their focus, laying the conceptual groundwork for the following sections that will provide additional detail and demonstrate the application of these concepts.

**The Requirements Domain (REQD).** is related to the very first engineering tasks of every modern software development process. As a result of these tasks, a set of requirements are extracted, which describe the desired system from a functional as well as a quality perspective. In order to further make use of the generated set of requirements,

a certain DSML needs to be defined. Natural language requirements with additional structuring capabilities as well as fully machine-processable requirement models are thinkable. For example a ReqIF-based DSML (see OMG REQIF v1.2 (2016)) can be used with most common CASE tools. Being able to reference specific requirements in a model or parts of them, enables developers to further use this semi-formal specification of the system for cross-domain traceability, thus extending the information base.

**The System Structure Domain (SSD).** contains the structural model of the system under development and reflects the architectural decomposition of the solution.

Our approach allows for a high degree of freedom regarding the actual implementation of the SSD model. For simple projects, the underlying GPML (see Section 2.1) itself may be sufficiently expressive to model the system structure without any domain-specific additions. For more complex systems, a modeling language with more powerful abstractions, such as SysML, can be integrated to describe the structural domain more adequately.

It should be noted that the SSD model may also be derived from a prior system description in case of a brown-field project. Here, it is feasible to use either existing architecture models as a basis for the newly defined integrated system model, or to reverse engineer a system description from its code artifacts.

**The System Behavior Domain (SBD).** contains modeling artifacts that describe the functional behavior of the system under development. As described above for the SSD, a range of modeling languages can be used to implement the behavioral model within our approach. Natural choices are the behavior diagrams found in the Unified Modeling

Language or its SysML extension.

However, different domain-specific modeling languages might be more familiar to designers of certain embedded systems; one example is the Function Block Diagram (FBD) notation for programmable logic controllers defined in the IEC 61131-3 and IEC 61499 international standards.

Given a suitable technology integration bridge (e.g. OSLC or ModelBus, see also Section 6), it is conceivable to integrate behavioral models from widely used simulation tools like Simulink or Stateflow, as an intermediate step while re-engineering legacy systems.

**The Safety and Reliability Domain (SRD).** covers the modeling and analysis of system reliability. Such analyses are invaluable and often mandated by regulations, e.g. in the development of safety-critical systems, to demonstrate the system's expected failure behavior and obtain measures of reliability and availability.

In order to quantify the reliability of a system, a thorough analysis of potential hazards and their associated risks is required. These hazard analyses require profound domain knowledge and are frequently performed as team efforts. Despite the interactive nature of these activities, their results can be formalized in the form of a hazard model that describes identified hazards and the risks as well as possible faults and failures that can cause these hazardous events.

A major task in the design of safety-critical systems is the classification of hazards based on their associated risk. Risks that are deemed intolerable, either by societal or regulatory standards, have to be mitigated by targeted risk reduction measures. Based on the necessary level of risk reduction, levels of safety integrity and associated safety requirements can be allocated to protective system components. This SIL allocation process requires the quantitative analysis of failure occurrence likelihoods.

Traditionally, such quantitative reliability models are maintained in separate tool environments, decoupled from the actual system model. This setup can lead to inconsistencies in reliability models and decisions made based on them, when proper care is not taken during ongoing development of the system. However, many common of the traditional reliability modeling approaches can easily be adapted for use in model-based environments. For example, the widely used Fault Tree Analysis (FTA) technique defines a set of graphical model elements to analyze failure causes in a system Vesely et al. (1981), and proves a suitable candidate for a domain-specific modeling

language with a familiar graphical representation.

By embedding the reliability and hazard analysis models into the integrated system model, our approach allows to easily maintain full traceability between these models and their associated system model counterparts in the SSD and SBD. Moreover, change impact analyses can be easily performed based on this traceability information, whenever a modification to any part of the system model is made.

In the context of model-based systems engineering, it makes sense to move beyond the traditional FTA technique and incorporate a component-based extension, such as the Component Fault Trees as proposed in Kaiser et al. (2003). This hierarchical structuring of reliability information creates synergies with the end-to-end traceability provided by our modeling approach.

**The Test Domain (TD).** reflects the information specific to the tester's view on the system under development. It can be used to formalize artifacts related to quality assurance activities, such as test plans, test cases, and test execution reports.

However, the true strength of the test domain model lies in the integrated support for model-based testing approaches. Depending on the expressiveness of the modeling languages used for the system description in the SSD and SBD, the test domain can be simply seen as an extension of these domains. However, it is also conceivable to embed model languages specific to the testing domain, such as the OMG-maintained UML Testing Profile, which provides modeling facilities for test behavior description as well as quality assurance management activities.

**The Integration Model (IM).** as illustrated in Figure 1, marks the central model artifact in order to establish a mechanism for domain-specific model linking and mapping of artifacts. The cross-domain linking, represented by the bidirectional connectors, on the one hand enables developers to make use of a solid and consistent tracing mechanism applicable throughout all development artifacts. On the other hand the IM is meant to provide additional information to the test engineer, previously out of scope. Therefore, distinct elements of the system model are mapped via the IM to concepts used in the test model. This also holds for other combinations of domain-specific model data. Note, that the IM does not model any information that has already been modeled in a connected domain. It only holds a subset of the resulting data generated by analyses performed on linked domains and establishes the

connections between its model artifacts. A necessary precondition for the seamless integration of all connected information domains is a common M3 metamodel definition for the tracing specific DSL parts.

**Other Domains.** The above modeling domains cover a wide range of engineering artifacts relevant during the design and construction of embedded and/or safety-critical systems. However, our modeling approach does not prescribe a fixed set of domain-specific modeling languages and domains and can easily be extended and tailored to each specific modeling use case.

The set of modeling domains presented above are relevant to the design of embedded systems in particular. However, our framework may also take into account aspects of business and other applications. To this end we envision domains addressing security and privacy considerations (e.g. to model information flows), timing models, description of data persistence, as well as usability models.

### 2.3 Purpose-specific Documentation

While the domain-specific models described above are derived from the GPML model through model-to-model transformations, our approach also covers the generation of purpose-specific textual artifacts through model-to-text transformations.

The automated generation of textual documentation is an important step towards more tightly integrated system engineering processes and plays a crucial role in the quality-driven architecture. The continuous and early design-time availability of textual design artifacts can support the subsequent fulfillment of process requirements.

The holistic nature of our proposed integrated system modeling approach facilitates document generation on a high abstraction level. For example, a common documentation requirement in safety-critical systems calls for seamless forward and backward traceability from system requirements down to the implementation level and its proper documentation. Since the Omni model contains all necessary architectural elements and their relationships, generating such documentation consistently and in an easily navigable format (for example as hyperlinked HTML documents) is an effortless automated task.

The use of hypertext formats is superior to traditional documentation formats for results of preliminary risk and hazard assessments. Current documentation artifacts used for the certification

of safety-critical systems commonly relies on spreadsheets and static PDF documents for this purpose. Using hypertext formats elegantly solves the problem of limited traceability of these documents. Since an HTML document allows to directly place links between the results of these assessments, their associated model elements, and related documents. This improvement allows easier familiarization with the system and better comprehension both as system documentation and for certification purposes.

Similarly, more formal certification artifacts can be generated from the integrated system model: The Goal Structuring Notation (GSN) is a graphical notation for representation of structured arguments, as in the case of safety or assurance cases for safety-critical systems Kelly and Weaver (2004). Hereby, the purpose of a formal argument notation is to tie claims about the safety of the system under development together with supporting evidence. Here, our approach can be used to generate a coherent set of safety documentation following the structured argument of a given GSN model based on the entire set of domain-specific models and analysis results contained in the integrated system model.

The availability of usable, consistent, and up-to-date textual artifacts can help to reduce cost of safety certification by supporting high quality and early review of certification-related documents.

Additionally, the same model-based document generation approach can be used to capture the results domain-specific analyses of the system that cover individual stakeholders' interests. From a project management standpoint, we envision this approach to be useful for analyzing certain Key Performance Indicators of the system, for example test and requirement coverage metrics as an indicator of overall project progress.

### 2.4 Code Generation

While out of the direct scope of our research, it should be noted that the final integrated system model is a suitable basis for generation of source code, as indicated by the second model-to-text transformation step in Figure 1. The integrated nature of the Omni model allows the code generation engine to make more educated decisions about the context of the source code to be synthesized. A possible scenario could be the automated application of defensive programming techniques in generated code, e.g. pre- and post-conditions or checksums, based on component contracts or safety requirements from the integrated system model.

### 3 MODEL-BASED ARCHITECTURE AND ANALYSIS FRAMEWORK

Based on the modeling approaches introduced in the previous section, we have developed a technology demonstrator geared towards the domain-aware modeling of safety-critical systems and their quality attributes. In addition to the domain-specific metamodels, the prototype includes a framework for definition of domain-specific architecture analyses, introduced below in Section 3.2.

#### 3.1 Technical Background

As shown in Figure 2, the analysis framework consists of three major components:

- Enterprise Architect as a general purpose modeling tool, used to provide the user interface for the system designer (Section 3.1.1)
- A relational database system for persistent storage of the model repository (Section 3.1.2)
- The actual architecture and analysis framework, which offers model analysis services via a web service interface (Section 3.1.3)

##### 3.1.1 Domain-specific Modeling in General Purpose Modeling Tool

The commercially available modeling and design platform *Enterprise Architect* (EA) by Sparx Systems serves as the central modeling tool for our demonstrator. As a general purpose modeling tool, it fully supports the UML 2.5 specification and includes an extension mechanism (dubbed *MDG Technologies*) as an implementation of UML profiles for use inside the EA modeling environment.

These MDG technology specifications can extend existing UML metaclasses as stereotypes with new attributes and define custom visual representations for use of these stereotypes in diagrams. We have developed custom MDG technologies for each of the domain-specific metamodels introduced in the previous section, to create the necessary modeling vocabulary to the system designer.

##### 3.1.2 Shared Model Repository Access

In its current form, the analysis server accesses the integrated system model through a relational database which is configured as the model repository inside Enterprise Architect. A custom-built object-relational mapper (EAORM) provides programmatic access to

the model repository and allows for its consistent modification. As described in Section 6, in the future we aim to replace this rather tight coupling between the tools by means of a model-oriented interoperability platform, such as ModelBus.

##### 3.1.3 Analysis Framework Integration

In order to anticipate a wider range of modeling tools, our analysis framework has been implemented as a stand-alone component outside the general purpose modeling environment. The functionality of the framework core is exposed through a graphical user interface for rapid feedback during development of model analysis, and a server component for remote access to the analysis functionality.

It provides a RESTful web service interface to the model analysis and textual artifact generation functionality. Communication between EA and the analysis framework is brokered by a thin web service client implemented as a custom plug-in inside Enterprise Architect.

It should be noted that no model representation is exchanged via the web service interface. Instead, both tools share access to a common model repository (see below), enabling them to refer to model elements solely by their identifiers. This approach allows the analysis framework to access a native representation of the entire integrated system model. While a generic model interchange format like XMI might satisfy the requirements for unidirectional exchange of model data between tools, problems arise in scenarios where bidirectional access is required. In order to keep the model consistent, the analysis framework needs to be able to persist the results of its analyses in the same model as its input data, therefore bidirectional access to the model is essential.

The clear architectural separation between modeling and analysis functionality facilitates another important use case: The analysis framework can be used independently from the design tool, for example as part of a continuous integration pipeline. Since all functionality of the framework is offered through a programmatic interface, the only necessary addition is a machine-readable description of the analyses to be executed. Such descriptions can even be stored as part of the integrated system model, creating a truly self-contained system model that spans the entire product lifecycle.

We have chosen the Operational QVT language (QVTo for short, see OMG QVT v1.3 (2016); Kurtev (2007) for details) as the model-to-model transformation language for our prototype. Each domain-specific model can be obtained from the integrated system model by applying its associated

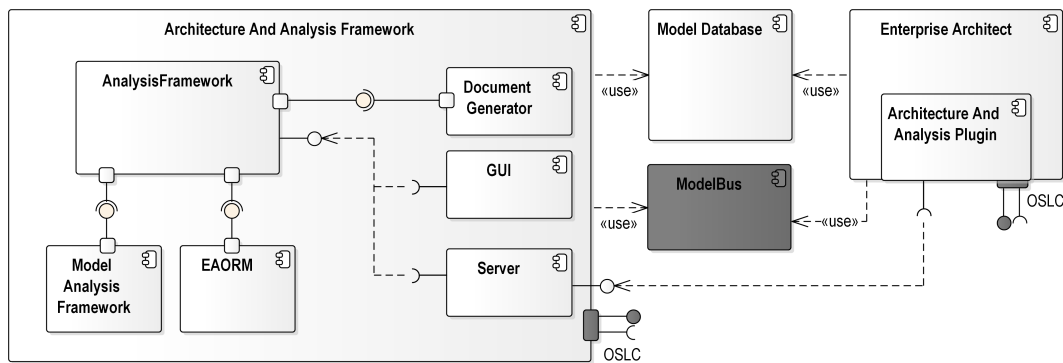

Figure 2: Technical overview of the reference technology platform architecture. Components shaded in dark gray refer to future extension possibilities, as described in Section 6.

transformation that maps the extended general purpose modeling language (see Section 2.1) onto the domain-specific modeling languages (Section 2.2). In order to simplify the integration with the Eclipse EMF-based QVTo implementation used, all domain-specific models have been implemented as Ecore metamodels.

Model analyses can define dependencies on the domain models necessary for their execution. The transformation engine in the analysis framework automatically determines the appropriate M2M transformations to be applied to the integrated system model when performing a model analysis.

### 3.1.4 Model-to-text Transformation

Since our prototype is focused on document generation as HTML pages, a general purpose templating language (Jtwig) was used for model-to-text transformation instead of a more formal M2T language. However, depending on the exact nature of the output format, M2T languages such as Eclipse Xtend or Xtext might provide more appropriate expressive capabilities – especially if the resulting textual artifacts should be expressed in a domain-specific language or integrated with an existing tool chain.

Code generation from the system model was beyond the scope of our developed prototype. For the purpose of our study, generation of C code from the integrated system model was delegated to an existing embedded systems engineering toolchain, that was adapted to make use of the additional domain-specific information contained in the Omni model.

## 3.2 Model-based Analyses

As part of the framework prototype, we have developed a range of model analyses, that can

be applied to the integrated system model and its constituent domain-specific models.

Conceptually, we have identified three major classes of model analyses, that can be distinguished by their types of input and output models:

**Validation Analyses.** consume one or multiple input domain-specific models, but do not generate any new model elements as their output. Rather, a validation analysis verifies the syntactic and semantic well-formedness of its input models. In case this validation fails, the analysis produces a report of the identified violations and returns it as a separate analysis result to the client.

Therefore, the purpose of validation analyses is the assurance of model integrity and quality. They are feasible candidates for tighter integration with the modeling environment, and can be executed continuously without user interaction to provide rapid feedback to the designer about the state and quality of the model being modified.

Note, that the existence of this class of analyses is a testament to the state of metamodel extensibility in current general-purpose modeling tools. Schleicher and Westfechtel have already highlighted this shortcoming in their 2001 paper and identified it as the primary driver for so-called *descriptive stereotypes*. If GPML tools provided first-class support for *restrictive stereotypes* or even full *restrictive metamodel extensions* instead, the syntactic and semantic constraints for a DSML could be directly validated as part of the metamodel extension.

**Calculation Analyses.** consume one or more input domain-specific models and calculate additional attributes for existing model elements, but do not add new elements.

These analyses can be seen as the formalization of a function application to their input models. Examples for this class of analysis are numerous, e.g. the automated update of probability information in reliability models, risk classification, or the analysis of timing bounds in behavioral models.

In our analysis framework, calculation analyses are an obvious application point for the Model Analysis Framework (MAF) described by Saad and Bauer (2013), which uses an application of data-flow analysis techniques originally introduced in compiler construction.

**Generative Analyses.** both consume and produce model elements in one or more domain-specific metamodels. As such, they are similar to model-to-model transformations, however, their purpose is more broad, so that they should be considered as a separate entity. Additionally, by implementing this type of transformation as an analysis inside our framework, they share a common interface with the remaining classes of analyses, helping to reduce complexity for the client.

Depending on their respective purpose, we can further distinguish endogenous and exogenous generative analyses, similar to the distinction found in the model transformation world.

Possible uses of this class of analyses are very broad: One possible example is the support of the system designer through wizard-type functionality, for example to generate skeleton reliability models from an existing structural model of a system. A different application scenario is the automated creation of a test model and test cases from the abstract description of system structure and functionality in the integration model.

Lastly, generative analyses can be used as the entry point for model-to-text transformations. They can be used to provide a consistent interface to make the creation of textual artifacts transparent to the client, hiding the added complexity of the actual invocation of the M2T transformation engine.

Analyses in our framework can be chained together to form more complex analysis scenarios. In order to guarantee consistency, analyses can declare execution order constraints. The analysis framework then determines an appropriate ordering of eligible analyses, performs the necessary M2M transformations, and then executes the actual analysis code.

## 4 CASE STUDY: RELIABILITY MODEL FOR A GAS HEATING BOILER

In the following section we will demonstrate the use of our domain-specific modeling approach to the reliability analysis of a gas heating boiler. Such boilers are commonly found in residential buildings to provide central heating by combustion of natural gas in a burner. The natural gas used in such a heating is highly flammable. Therefore, the design of such a system must include an evaluation of the safety risks and reliability of its protection systems, to minimize the risk of personal injury arising from a malfunction.

Due to the limited space in this paper, the artifacts shown in this case study represent only a small subset of the overall system model. However, they nicely illustrate the application of our integrated modeling approach and its suitability for the development of safety-critical systems.

### 4.1 System Structure and Behavior

Since we are describing the system architecture on a very abstract level, a plain UML component diagram provides appropriate expressive capabilities to describe the system structural domain for this case study. Figure 3 gives a high-level architecture overview for the gas heating boiler of our example system. Such a model can be derived at early design stages, as soon as the operational context of the systems has been determined.

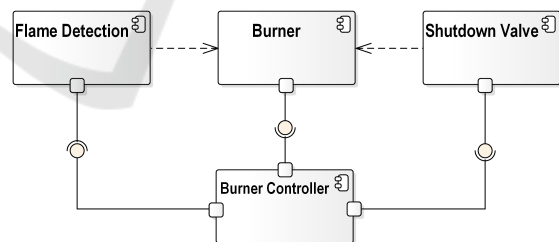

Figure 3: Architecture of the gas heating system.

We use UML state machines to model the behavior of the burner controller, which monitors and controls the combustion of natural gas inside the burner. As an example, Figure 4 describes the main operating states of the burner controller, which can be either operational or shut down in case a malfunction of the flame supervision mechanism has been detected.



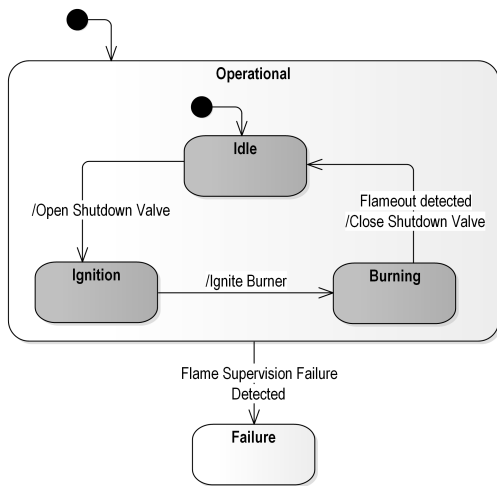

Figure 4: Behavior model of the burner control logic.

### 4.2 Reliability Model

An early step during development of a safety-critical system is the assessment of potential hazards and risk associated with the system under development (see section 7.4 of IEC 61508-1:2010 (2010) for details). This hazard and risk assessment, performed by a team of domain experts, can be documented in a risk assessment model.

Based on this initial assessment, mitigation measures are defined for safety-relevant hazards to determine the necessary risk reduction to achieve a tolerable risk. A Fault Tree Analysis (FTA) can be carried out to quantitatively determine the actual likelihood for a given hazard based on the hazard assessment and the proposed levels of protection.

As an illustrative example, we have chosen to analyze a potentially hazardous failure of the heating system, namely the presence of uncombusted gas in the burner chamber following a flameout. This situation can lead to rupture of the heating vessel due to over-pressurization or rapid deflagration or explosion of the uncombusted gas in the presence of an igniting spark. Both hazards are assumed to occur with an intolerably high likelihood, which prompts the addition of a flame detection mechanism and an automatic safety shutdown valve to the heating system.

Figure 5 shows the fault tree model for this hazardous event, highlighting the two components of the analysis: the root causes for the hazardous event, and the simultaneous failure of protective safety functions. Note that all basic events can be further developed – the fault tree has been truncated to fit the scope of the use case.

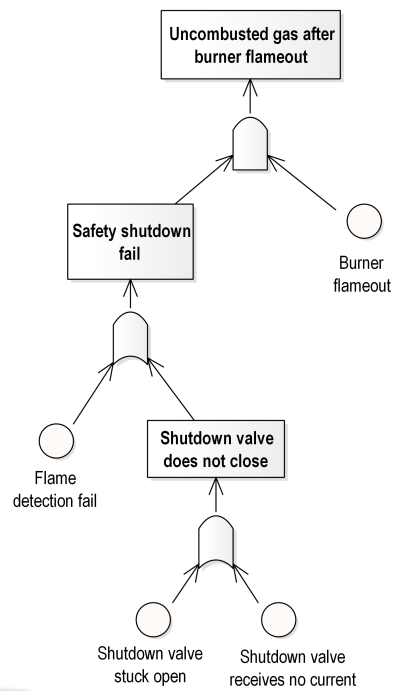

Figure 5: Fault tree model for hazardous event *Uncombusted Gas after Burner Flameout*.

### 4.3 Requirements Model

Based on an annotation of the acceptable risk target for the hazardous event in the model and the occurrence likelihood of the root causes for the flameout (calculated through an architecture analysis), our framework can identify necessary safety function and allocate safety integrity levels to them (see sections 7.5 and 7.6 of IEC 61508-1:2010 (2010) for the regulatory background).

Figure 6 shows a part of the safety requirements model for the previously discussed risk of uncombusted gas. A safety function with a specified safety integrity level is required to mitigate this risk, and is allocated to a system component, namely the burner controller.

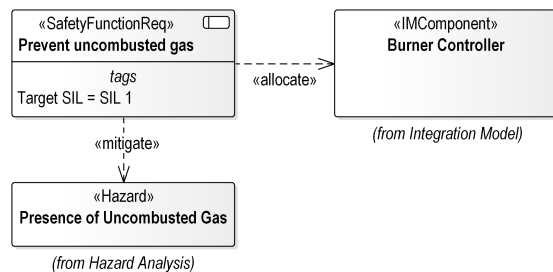

Figure 6: Safety requirements model.

Note, that besides this domain-specific model of safety requirements, a complete integrated system model of the gas heating would also contain all functional requirements that govern the regular operation of the system.

#### 4.4 Integration Model

The integration model for our use case ties together the system structure and behavioral domain, with all additional domain-specific models regarding the reliability of the heating system.

We can see from Figure 7 that the integration model forms a hierarchy of abstract components with the entire system under development at its root. Furthermore, the IM reflects the allocation of abstract functionality, e.g. the logic of the burner controller, to components and contains traceability information into the concrete behavioral model. In our example, the integration model associates the state machine for the burner control (see Figure 4) with the abstract control logic functionality.

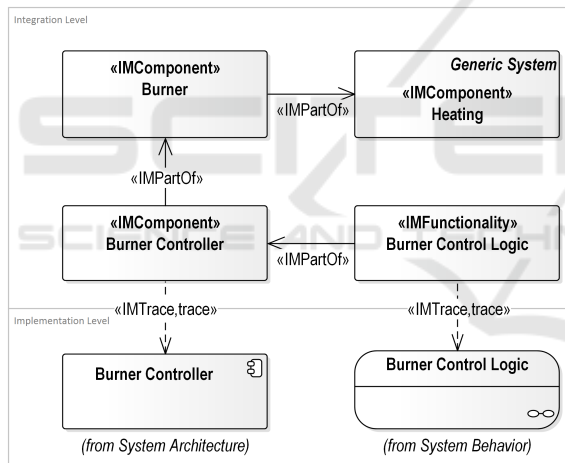

Figure 7: Excerpt from Integration Model with links to SSD and SBD.

Beyond this abstract description of the system behavior and structure, the integration model plays a crucial role for maintaining the consistency of the reliability model. By establishing a link between identified hazards, failure events in fault tree models, and the associated system components (as seen in Figure 8), the IM forms the basis for the integrated consideration of reliability and risk management activities during the design of the heating system. Based on this information, accompanying documentation can be generated to be used as evidence in safety certification of the burner control system.

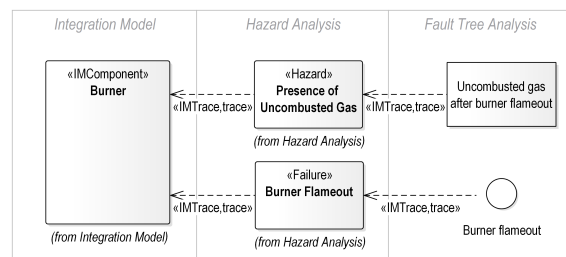

Figure 8: Excerpt from Integration Model with links for reliability model.

## 5 RELATED WORK

Our work relates to previous research in three related, but separate fields: Firstly, our approach provides a means of integrating various engineering disciplines into a coherent tool environment. Each of these disciplines brings with it its own set of domain-specific engineering artifacts and modeling languages. Finally, our implementation of an architecture analysis framework based on an integrated system model relates to prior work in the field of model-based analysis.

The following sections give a short overview of the relevant literature in these three fields, as they related to our current research.

### 5.1 Modeling Tool Integration

In his seminal work, Wasserman (1990) describes an approach for integration of heterogeneous tools in a software engineering tool chain. He describes an integrated software engineering framework based on three cardinal dimensions of interoperability – presentation, data, and platform integration.

The EU-funded iFEST project (Industrial Framework for Embedded Systems Tools<sup>1</sup>) was aimed at developing an integrated framework for embedded systems, addressing both software and hardware concerns. The iFEST approach specifies a tool integration framework that leverages the OSLC specification to allow data exchange between heterogeneous modeling tools. Since it is focused exclusively on the aspect of tool integration, this approach does not address the field of model-based analyses of the integrated system model.

### 5.2 Domain-specific Modeling

Zschaler et al. (2009) proposes a generalization of DSLs to domain-specific modeling languages, in

<sup>1</sup><http://www.artemis-ifest.eu/>

order to capture common concepts found in families of related DSLs and facilitate automation.

Similarly, de Lara et al. (2015) describe an approach for domain-specific multi-level metamodeling languages, allowing for the definition of deep language hierarchies. Their approach contains a set of reusable metamodel transformations for management of multi-level metamodeling languages and describes approaches for code generation in such a setting.

The use of UML as a graphical visualization language for domain-specific modeling languages is proposed by Graaf and van Deursen (2007). Their work proposes model-to-model transformations as a means of deriving a visual representation from a domain-specific model. Conceptually, these transformations can be regarded as an embedding of the DSML into a generic-purpose modeling language, namely into UML.

### 5.3 Model-based Analysis

Papadopoulos and McDermid (1999) introduce HiP-HOPS (Hierarchically Performed Hazard Origin and Propagation Studies), a methodology for model-based hierarchical reliability analysis of component-based systems. Based on the architecture of the system under analysis and certain failure annotations, HiP-HOPS allows for bottom-up generation of Fault Trees and so-called interface-focused FMEA results for a system. Under the HiP-HOPS methodology, components are augmented with additional model information about their failure behavior. Various classes of interface failures are defined, that can be used to describe the black-box failure model of a system on a component level.

This approach has subsequently been extended to accommodate aspects of automatic architecture optimization. Papadopoulos et al. (2010) describes a conceptual approach for the automatic allocation of safety integrity levels to components of safety-critical systems. This work is focused on the automotive domain and uses the EAST-ADL2 modeling language for architecture description. Similarly, Papadopoulos et al. (2011) proposes a more generic architecture optimization approach based on the HiP-HOPS methodology and the use of genetic algorithms.

A complementary approach can be found in the EU-funded MBAT project (Combined Model-based Analysis and Testing of Embedded Systems<sup>2</sup>). This project aimed to provide a methodology and technology platform for specification of system

<sup>2</sup><http://www.mbat-artemis.eu/>

analysis and V&V activities in the context of embedded system engineering. The central element of the proposed methodology is the so-called *A&T model* (short for [static] analysis and [model-based] testing), highlighting the focus of the approach to the quality-assurance domain.

## 6 CONCLUSIONS

We have proposed a valuable approach for integrated system modeling and model-based architecture analysis.

Our work introduces a solution to the challenge of integrating both system modeling and quality-related artifacts in the design and implementation of embedded systems. The resulting integrated system model or Omni model establishes explicit traceability between domain-specific modeling artifacts and enables consistent change management and change impact analyses.

Based on this holistic, model-based view on the entire system under development, purpose-specific textual artifacts can be generated in an automated fashion through the use of model-to-text transformations.

We have developed a reference technology platform that combines this integrated system modeling approach with a model-based analysis framework. The suitability of this prototype is demonstrated through a case study, which illustrates the use of the framework to model the reliability aspects of a residential gas heating burner, a simple safety-critical embedded system.

### Future Work

While our technology prototype has shown the feasibility of our theoretical approach, we see several possible fields for improvement and extension of the architecture and analysis framework:

In order to reduce the need for re-creation of existing domain-specific modeling artifacts inside a general-purpose modeling tool, existing modeling tools can be integrated by means of a technology integration bridge. OSLC<sup>3</sup> (Open Services for Lifecycle Collaboration) and ModelBus<sup>4</sup> are two suitable candidates for such an integration platform. Both aim to provide heterogeneous tool integration through open, web-based technologies and could be used to establish transparent traceability between our

<sup>3</sup><http://www.open-services.net>

<sup>4</sup><http://www.modelbus.org>

proposed integration model and models distributed across one or more domain-specific tools. Figure 2 illustrates the addition of OSLC and/or ModelBus to our reference technology platform as part of the model-based analysis framework.

A similar argument can be made for a more generic access to a shared model repository. Currently, our prototype shares a relational database for the integrated system model with the proprietary Enterprise Architect model repository. ModelBus, with its integrated model repository component (see Hein et al. (2009), section 2), can help to reduce this tight coupling between the generic persistence layer and a single modeling tool.

Besides the technical improvements, we foresee a worthwhile extension of our modeling approach with aspects of contract-based design. Since our integrated system model already encompasses comprehensive information about non-functional aspects of the system under development, this knowledge can be used to derive constraints and guarantees for system components. The automated nature of our analysis framework allows for design optimization based on domain-specific models. Information about component prerequisites and guarantees in the form of contracts can be used to reduce the complexity of the design space during such automatic architecture optimization.

## ACKNOWLEDGEMENTS

The research in this paper was funded by the German Federal Ministry for Economic Affairs and Energy under the Central Innovation Program for SMEs (ZIM), grant numbers KF 2751303LT4 and 16KN044120.

## REFERENCES

- de Lara, J., Guerra, E., and Cuadrado, J. S. (2015). Model-driven engineering with domain-specific meta-modelling languages. *Software & Systems Modeling*, 14(1):429–459.
- Graaf, B. and van Deursen, A. (2007). Visualisation of domain-specific modelling languages using uml. In *14th Annual IEEE International Conference and Workshops on the Engineering of Computer-Based Systems (ECBS'07)*, pages 586–595. IEEE.
- Hein, C., Ritter, T., and Wagner, M. (2009). Model-driven tool integration with modelbus. In *Workshop Future Trends of Model-Driven Development*, pages 50–52.
- IEC 61508-1:2010 (2010). Functional safety of electrical/electronic/programmable electronic safety-related systems - Part 1: General requirements. Standard, International Electrotechnical Commission, Geneva, CH.
- Kaiser, B., Liggesmeyer, P., and Mäckel, O. (2003). A new component concept for fault trees. In *Proceedings of the 8th Australian workshop on Safety critical systems and software-Volume 33*, pages 37–46. Australian Computer Society, Inc.
- Kelly, T. and Weaver, R. (2004). The Goal Structuring Notation—A Safety Argument Notation. In *Proc. of Dependable Systems and Networks 2004 Workshop on Assurance Cases*.
- Kurtev, I. (2007). State of the art of QVT: A model transformation language standard. In *International Symposium on Applications of Graph Transformations with Industrial Relevance*, pages 377–393. Springer.
- OMG QVT v1.3 (2016). Meta Object Facility (MOF) 2.0 Query/View/Transformation Specification, Version 1.3. Specification, Object Management Group (OMG), Needham, MA.
- OMG REQIF v1.2 (2016). Requirements Interchange Format (ReqIF), Version 1.2. Specification, Object Management Group (OMG), Needham, MA.
- Papadopoulos, Y. et al. (2010). Automatic allocation of safety integrity levels. In *Proceedings of the 1st workshop on critical automotive applications: robustness & safety*, pages 7–10. ACM.
- Papadopoulos, Y. et al. (2011). Engineering failure analysis and design optimisation with HiP-HOPS. *Engineering Failure Analysis*, 18(2):590–608.
- Papadopoulos, Y. and McDermid, J. A. (1999). Hierarchically performed hazard origin and propagation studies. In *International Conference on Computer Safety, Reliability, and Security*, pages 139–152. Springer.
- Saad, C. and Bauer, B. (2013). *Data-Flow Based Model Analysis and Its Applications*, pages 707–723. Springer Berlin Heidelberg, Berlin, Heidelberg.
- Schleicher, A. and Westfechtel, B. (2001). Beyond stereotyping: Metamodeling approaches for the UML. In *Proceedings of the 34th Annual Hawaii International Conference on System Sciences*, page 10 pp. IEEE.
- Sommerville, I. (2011). *Software Engineering*. Pearson Education, 9th edition.
- Vesely, W. E., Goldberg, F. F., Roberts, N. H., and Haasl, D. F. (1981). Fault tree handbook. Technical report, DTIC Document.
- Wasserman, A. I. (1990). Tool integration in software engineering environments. In *Software Engineering Environments*, pages 137–149. Springer.
- Zschaler, S., Kolovos, D. S., Drivalos, N., Paige, R. F., and Rashid, A. (2009). Domain-specific metamodeling languages for software language engineering. In *International Conference on Software Language Engineering*, pages 334–353. Springer.