

© 2018 IEEE

HYDRO 2018

High Power Electronics Innovation Perspectives for Pumped Storage Power Plants

M. Basic, P. Silva, and D. Dujic

This material is posted here with permission of the IEEE. Such permission of the IEEE does not in any way imply IEEE endorsement of any of EPFL's products or services. Internal or personal use of this material is permitted. However, permission to reprint / republish this material for advertising or promotional purposes or for creating new collective works for resale or redistribution must be obtained from the IEEE by writing to pubs-permissions@ieee.org. By choosing to view this document, you agree to all provisions of the copyright laws protecting it.

High Power Electronics Innovation Perspectives for Pumped Storage Power Plants

Miodrag Basić, Pedro C.O. Silva, Dražen Dujčić

Power Electronics Laboratory
EPFL STI IEL PEL, Station 11
1015 Lausanne, Switzerland
<https://pel.epfl.ch>

Abstract

The current framework of high penetration of intermittent energy sources requires variable-speed pumped hydro storage power plants (PHSPs) to provide grid support functions, which are, in this case, achieved through two technologies: doubly-fed induction machine (DFIM), and converter-fed synchronous machine (CFSM). Up to now, limitations of power electronics solutions favoured DFIM due to smaller converter in rotor circuit. This paper presents innovation perspectives for variable-speed PHSPs by presenting a potential future solution: the CFSM configuration employing the modular multilevel converter (MMC). MMC offers almost unrestricted voltage and power scalability. Featuring significantly increased output voltage resolution and scalability, MMC offers in perspective removal, or at least considerable reduction, of the filters and/or transformers, reducing size and cost of installations. This paper discusses potential MMC advantages and drawbacks for variable-speed PHSP applications compared to conventional technologies, considering all the features expected from a flexible PHSP in the current and future electrical grid.

1 Introduction

Pumped hydro storage power plants (PHSP) have been in use for decades, thus representing a well-established and proven technology. With an overall efficiency typically ranging between 70 and 85%, they offer the most efficient means of storing electrical energy at large scales [1], [2]. Featuring short start-up times and high flexibility, these have by far the highest share in installed capacity compared to all energy storage techniques, reaching roughly 130GW of installed capacity worldwide [3].

A traditional PHSP is based on a grid-connected synchronous machine, and a specific hydraulic system. The synchronous machine is connected to transmission grid through a step-up transformer and thus operates at fixed frequency. The hydraulic system is most commonly realized using a reversible pump-turbine unit of Francis type [2]. In this case, a change of operating regime (generation/pumping) requires a change of direction of rotation. Another option is so-called ternary system, where turbine and pump are built as separate units and connected to a single synchronous machine. This approach enables independent optimization of both pump and turbine, along with faster switchover between operating regimes, as direction of rotation can be the same.

Traditionally, PHSPs are used for pumping during off-peak hours, storing excess energy from base generators like thermal and nuclear power plants, allowing their operation at constant, optimal power point, regardless of current consumption. During peak hours, PHSPs are used in generation mode, successfully balancing production-demand and providing “peak-shaving”. This flexibility was the main motivation for development of PHSPs in the 1970s [1], [2].

Supported by various government incentives from economical side and advances in power electronics from technological side, renewable energy sources (RES) have gained a significant market share in recent years. The most dominant in terms of installed power, photovoltaic (PV) and wind sources, are however inherently stochastic, highly dependent on weather conditions, and thus challenging to predict over longer time horizons. With a total share in globally installed generation capacity currently being more than 402GW for wind, and 539GW for PV plants [4], these intermittent sources require a counter-balance in form of a reliable and fast storage system, for production-load balancing. Regarding transmission system operators’ (TSO) scheduling models, it has been shown that the share of installed wind plants has a direct impact on the amount and type of the required operation reserves [4], [5].

An additional challenge to traditional operation of PHSPs has been set since the 1990s, by gradual deregulation of once centralized electrical energy markets. This change has, in general, introduced three groups of wholesale markets for exchange of electrical energy and services: day-ahead (spot), intraday and ancillary services. The day-ahead market is where electrical energy producers and consumers both place bids for selling and buying electrical energy over a defined time horizon (one day or more). The prices and daily production schedule are

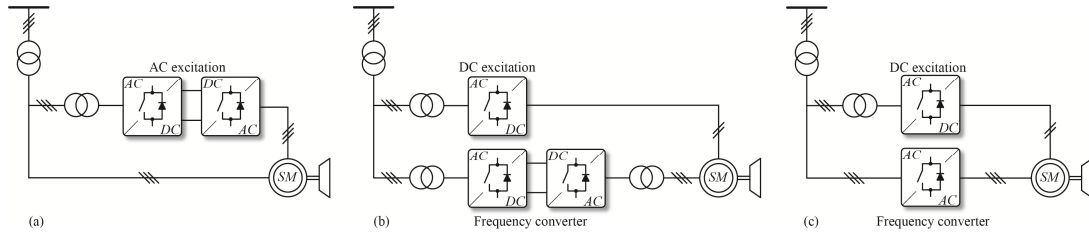

Fig. 1. Variable-speed PHSPs configurations: (a) DFIM; (b) CFSM; (c) Future CFSM realized with new power electronic technologies.

determined after market clearing, by an independent supervisor, known as Market operator [4]. Certain deviations from the production schedule and consumption estimate can naturally occur, by both technical and environmental causes. Intraday markets are organized in the same fashion as spot markets, with a purpose of compensating for deviations in planned day-ahead production and consumption schedules [6]. Electrical energy is traded for balancing within a specific day. Ancillary markets are organized for various services: frequency regulation, voltage control, power reserves.

Nowadays, as a consequence of significant share of stochastic renewable sources, considerable peaks and dips in production and demand can occur throughout the day (PV, wind) and night (wind). With prices being formed based on demand and offer on the market, the once fairly estimable daily cost curve of electrical energy can now be significantly deviated. Profitability of traditional operation of PHSPs is directly proportional to the ratio of peak and off-peak cost of electricity on spot markets. On the other hand, ancillary services markets are considerably enlarged due to the aforementioned effects of RES uncertainties.

In this sense, the introduction of power electronic converters to PHSPs can provide higher control flexibility, increasing their presence and making them more competitive in ancillary markets. Advances in power electronics, in both switching devices blocking capabilities and topologies, have enabled converter power ratings that match some PHSP machine ratings [7]. Implementation of such converters to PHSPs is possible for both synchronous machines (Figure 1(b-c)), and doubly-fed induction machines (Figure 1(a)). In both cases, they offer decoupling of machine's mechanical speed from grid frequency. In practice, this means the machine can be controlled during pumping regime in a way to operate at variable speed, while maintaining fixed frequency at grid terminals, expanding power-frequency regulation service offer to all working regimes. Instantaneous power injection can be offered as well, by using high rotor inertia as a flywheel effect. Again, rotor speed dip in that case is tolerable due to the aforementioned decoupling effect. In synchronous machine solution, since machine is completely decoupled from the grid, reactive power can be offered to the grid from the converter, regardless of the machine operating state, even during standstill or low-voltage ride-through situations.

By offering both energy at spot market and ancillary services like power-frequency regulation, a PHSP could increase overall results. Some researchers suggest this strategy, using certain heuristic algorithms to decide on capacity placement between the markets, could potentially double the daily income of a PHSP [4], [8]. In a real-world example of a Portuguese power system, secondary regulation reserve is shown to be the most important source of revenue for a PHSP [9].

2 State-of-the-art in variable-speed PHSP technologies

The possibility of pumping water at variable power, thus providing power-frequency control in pumping mode [9], is one of the main advantages of variable-speed PHSPs over fixed-speed ones. As a consequence, their development began in Japan in the 1990s, with a clear goal of reducing the number of large thermal power plants operating in reserve mode during the night [2].

Variable speed operation can be obtained through two main technologies: doubly-fed induction machine (DFIM) and converter-fed synchronous machine (CFSM). Even though variable pumping power can also be achieved with fixed-speed machines through the use of so-called hydraulic short circuit operation with ternary units [10], no other benefits of variable-speed PHSPs can be met by this technique. Thus, it will not be considered.

2.1 Doubly-fed induction machines

The DFIM configuration (Figure 1(a)) is the most consolidated technology used for variable-speed PHSPs, especially for machines of high power ratings, exceeding 100 MW. While the stator is connected directly to the grid, variable low frequency currents are applied to the rotor windings of the induction machine through a power electronic converter. The advantage of this configuration is the fact that the converter has to be rated to only around 30% of the nominal power of the machine to achieve $\pm 10\%$ of speed variation. This, in turn, provides roughly $\pm 30\%$ of pumping power variation [11]. Converters of these power levels are technologically available, making DFIM an already established technology.

Table 1. Variable-speed PHSP units above 100MW currently in operation or under construction

Name	Country	Type	Turbine power [MW]	No. of units	Total power [MW]
Kazunogawa 3 and 4	Japan	DFIM	460	1	460
Okawachi 1 and 2	Japan	DFIM	395	2	790
Frades II	Portugal	DFIM	390	2	780
Venda Nova 3	Portugal	DFIM	380	2	760
Okukiyotsu 2	Japan	DFIM	340	1	340
Omarugawa 1 and 3	Japan	DFIM	330	2	660
Omarugawa 2	Japan	DFIM	330	1	330
Okutataragi	Japan	DFIM	320	2	640
Omarugawa 4	Japan	DFIM	310	1	310
Shiobara	Japan	DFIM	309	1	309
Fengning 2	China	DFIM	300	2	600
Goldisthal	Germany	DFIM	265	4	1060
Linth-Limmern	Switzerland	DFIM	250	4	1000
Tehri	India	DFIM	250	4	1000
Le Cheylas	France	DFIM	240	1	240
Kyogoku 1 and 2	Japan	DFIM	230	2	460
Avče	Slovenia	DFIM	180	1	180
Nant de Drance	Switzerland	DFIM	150	6	900
Takami 2	Japan	DFIM	103	1	103
Grimsel 2	Switzerland	CFSM	100	1	100

A list of variable-speed units over 100MW known to authors, currently in operation or under construction, is given in Table 1, based on [1], [12], [13]. The absolute majority of units are DFIM, Grimsel 2 being the only CFSM on the list. World's first variable-speed unit, as well as the following installations were realized with thyristor-based cycloconverters [1], [14]. The plants are nowadays comprising voltage source converters (VSC), with either transistor- (IGBT) or thyristor-based (GTO, GCT) switches [1]. The highest single-converter power ratings are achieved through three-level (3L) neutral-point-clamped (NPC) and Active NPC (ANPC) topologies, where the so-called ANPC has further increased power density through introduction of two additional switches compared to NPC. Thanks to better load sharing among the switches and the use of lower on-state loss thyristors (RC-IGCT), an increase of 50% in power density and 80% in output power are claimed [15], [16]. Five-level (5L) ANPC solution is also available [17], while another manufacturer offers IGBT-based converter of undisclosed topology for 37MW level at 13,8kV, with a possibility of parallel operation of such converters to achieve up to 300MW [15]. This places both DFIM and significant number of SM units within the range of available power electronic converters.

The use of DFIM enables operation at fixed (grid) frequency of stator windings, while varying rotor mechanical speed, according to the equation (1):

$$f_{stator} = \frac{n \cdot p}{60} \pm f_{rotor} \quad (1)$$

where p is the number of pole pairs, and n represents mechanical speed in rpm. Rotor frequency sign depends on the direction of rotating magnetic field. This property enables to instantaneously inject spikes of considerable additional power to the grid in case of disturbances, by exploiting rotor as a flywheel. A consequential drop of mechanical speed can be compensated by changing f_{rotor} supplied from power converter, instead of a slower mechanical turbine control process. The use of this feature effectively allows reduction of grid spinning reserve [11].

Additional benefits of DFIM can be observed on power plant side. A significant extension of operating range, in terms of maximum to minimum head ratio, is achievable compared to fixed-speed PHSPs – 1,45 compared to 1,25 is claimed by [2]. Additionally, overall hydraulic efficiency, a function of head, discharge rate and speed of rotation, can be increased throughout the aforementioned range. Variable speed operation in Francis-type pump/turbine unit enables to operate at different speeds in pumping and generation mode, achieving optimal working points of hydraulic circuit for both regimes. Reduced hydraulic stresses and expected increase in hydraulic machines' lifetime are benefits worth mentioning.

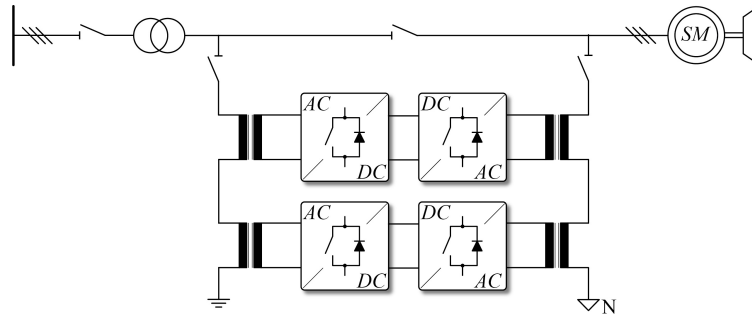

Fig. 2. CFM layout in Grimsel 2 PHSP, including converter bypass switch for turbine (generation) regime.

However, several drawbacks exist for the DFIM configuration. The wound rotor is complex in design, introduces slip rings as an additional maintenance issue, and has a limited power according to cooling capabilities of the machine. In practice, rotor power is roughly limited to 15% of rated machine power, limiting available speed range and starting torque. Limited starting torque, in return, may be insufficient when switching between generation and pumping, requiring a dewatering procedure, a time- and resource-consuming task.

During grid faults resulting in short circuit, low voltage ride-through (LVRT) proves to be challenging for DFIM. High rotor currents in short circuit conditions reach values well above rated, overloading the converter. In case rotor supply converter enters protected mode, rotor windings are short-circuited, and DFIM acts as a consumer of reactive power, negatively contributing to LVRT situation. Special requirements for DFIM during LVRT thus require the machine to be controlled for some time during the fault. In practice, this means that converter must be oversized to withstand the requirement. The degree of oversizing depends heavily on required length of operation, and can reach values 3-4 p.u. higher than rated ones.

2.2 Converter-fed synchronous machines

Recent advances in power electronics semiconductors and topologies have enabled full-size converter between machine and grid to be considered, in what is called CFM configuration (Figure 1(b)). The use of a standard synchronous machine (SM) decoupled from the grid through the converter offers considerable benefits. Retrofit of existing fixed-speed PHSPs, if available cavern space permits, is possible without replacement of the machine itself. Thanks to a less complex rotor design, higher rotational speeds can be achieved compared to DFIM.

Since the machine is converter-fed, substantial torque is available from zero speed, dismissing the need for dewatering procedure when switching between generation and pumping. As a change in rotating magnetic field direction of the machine's stator can be achieved through appropriate change in converter output voltage reference, there is no need for additional pole reversing installation.

Regarding short circuit conditions in the grid, converter current limit can be freely parametrized and, for instance, limited to 1 p.u. This eliminates the need for oversized converter. From the grid point of view, PHSP behaviour during fault is no longer defined by nature of the machine. Considerable reactive power can be delivered to the grid, while in control of short circuit current, which is beneficial for both LVRT and the plant itself. Furthermore, reactive power can be supplied regardless of the machine operating state, even when machine is at standstill (STATCOM operation). Since reactive power can be supplied from the converter, rather than from the machine, SM can be designed for higher power factor, i.e. more compact size.

Lower-power CFM units, of up to 50MW, for heads up to 250m and flow rates of 40m³/h, have been proposed as a means of local balancing, to be placed in the vicinity of stochastic RES plants [18]. These power levels can be processed through readily available power electronic converter technologies.

2.2.1 Power range of interest and current installations

Regarding higher-power rated converters for SM units in the order of 100MW and up, which can be found in existing PHSP installations, and are the focus of this paper, there is only one installation based on CFM currently in operation. It is a 100MW unit installed in Grimsel 2 power plant, located in Switzerland. The plant comprises four 90MW/13,5kV ternary machine units [7]. One of the machine sets has been retrofitted with a full power electronic converter supply.

Due to technical limitations in available technology, the required power has been achieved through the parallel operation of two 50MW back-to-back converters, developed by ABB, and based on IGCT. Currently available semiconductor devices in this power range do not enable both high enough voltage and current levels to match typical machine ratings, implying the use of both grid- and machine-side converter transformers. The converter layout in presented in Figure 2. It should be noted that this form of converter stacking produces beneficial multilevel output voltage waveforms. The achieved pumping power regulation is 60-100MW [7].

2.2.2 Monolithic multilevel converters technology limitations

Voltage levels of 3,3kV to 6,6kV line-to-line are at limits of reach for majority of today's medium voltage converters, not considering topologies that require specific transformers and can thus achieve higher voltages, e.g. Robicon cascaded H-bridge [19]. The rating can be multiplied through series connection of converter units, by means of interleaving transformers as in Grimsel 2 (Figure 2). A higher voltage rating can alternatively be achieved by stacking semiconductors within a single converter arm, as in [15]. Further increase in current rating is possible through parallel operation of such units. Table 2 provides an overview of maximum ratings for medium voltage (MV) monolithic VSCs, as advertised by some of the major manufacturers [15], [20], [21].

Table 2. Maximum achievable monolithic converters power ratings, as advertised by some of the major manufacturers

Manufacturer	Model	Technology	Voltage	Power
ABB	ACS 6000	3-L IGCT	3,3kV	36MW
GE	MV 7	5-L IGBT	13,8kV	37MW
Siemens	SINAMICS SM 150	3-L IGCT	3,3kV	30MW

It should be noted that GE MV7's higher voltage rating is achieved through stacking of eight low voltage IGBTs. This naturally decreases reliability, while increasing circuit complexity. GE also advertises possibility of up to 300MW output power through parallel operation of listed units. Similarly, Siemens utilizes three 3L NPC converters in parallel for listed rating.

The scalability, however, is limited. As in Figure 2, each additional series-connected converter requires a set of grid- and machine-side interleaving transformers. In case of limited number of levels, high dv/dt values can be putting extra stress to machine windings' insulation. PHSPs that are candidates for conversion from fixed- to variable-speed pumping are based on older SMs designed for grid voltage waveforms. The insulation of these machines, subjected to high dv/dt stresses of VSC output, would age significantly faster and deteriorate. This limitation introduces the need for filtering, which directly translates to additional space, losses and financial requirements, with first two being critical in limited cavern spaces. Looking at the equipment displacement in [22], it can be seen that passive equipment – transformers and filters, takes up roughly half of the total volume. Limited voltage levels require higher current ratings to achieve desired power levels. This, in turn, leads to problems with handling high short circuit currents in case of converter faults. Issues with harmonic distortions could, depending on power system regulations, require additional filtering on grid side.

On the other hand, the concept of Modular Multilevel Converter (MMC) [23] overcomes scaling limitations through simple stacking of unrestricted number of submodules in converter arms (Figure 3). The submodules could be realized as unipolar (half-bridge) or bipolar (full-bridge) units, through well-established semiconductor components. This strategy makes PHSP machine voltage levels reachable within a single converter, dismissing the need for interleaving transformers.

3 CFSM perspective with Modular Multilevel Converters (MMC)

To achieve very high power levels implied by the PHSP application, independently of current semiconductor technology limitations, a topology with better scalability is required. Modular Multilevel Converter, first introduced in [23] is a promising alternative to monolithic converters. In scenarios where two AC systems are to be interconnected, there are two possible topologies – indirect (I-MMC) and direct (D-MMC), depicted in Figure 3. Converter bypass has not been drawn for simplicity. In practice, the converter can be bypassed during generation regime to decrease overall losses, in the same fashion as in Figure 2. Indirect, or back-to-back MMC is well established in point-to-point HVDC bulk energy transmission. Direct MMC found its use in static frequency converters (SFC) for railway inerties, as an interface between three-phase 50Hz public grid and single-phase 16,7Hz railway supply; a reference to a recent 2x40MW unit in Geneva can be found in [24]. In these established applications, MMC is interfacing two grids of fixed frequencies, while in case of PHSP, electric machine side of the installation operates at variable frequency, which introduces its own challenges.

The building block of an MMC is a submodule, comprising standard switching elements (IGBT or IGCT) either in basic half-bridge (HB) or full-bridge (FB) configuration, or some of the alternative ones, and a capacitor bank. Converter arms are realized as strings of these submodules, making very high voltage levels achievable with available semiconductor technologies. Since each submodule is controlled independently, output voltage is of multilevel waveform. This is beneficial in terms of lower stress on machine windings insulation, enabling retrofit with older machines without additional dv/dt filtering.

In monolithic back-to-back VSCs, a central DC bus capacitor bank stores the total converter energy. For high power converters, in case of faults, it is very challenging to handle high short-circuit currents and consequential mechanical stresses provided by such a source. In an MMC, energy storage is evenly distributed in submodules, making fault management easier. High availability of the converter in case of submodule failure is achieved through redundancy, by stacking additional submodules in converter arms. Operation can be continued after electrical bypass of failed submodule, which is replaced during scheduled periodic maintenance, e.g. yearly.

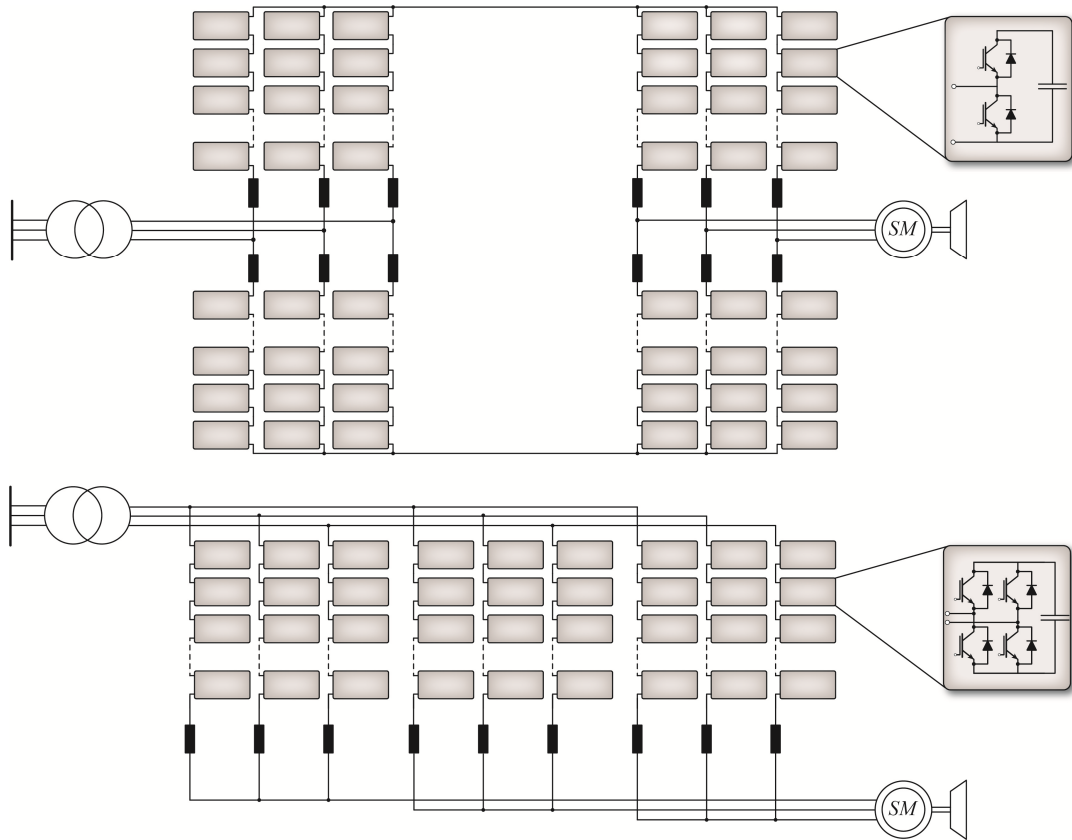

Fig. 3. Indirect MMC (up) and direct MMC (down) topologies.

3.1 MMC scaling for PHSP

Based on technological constraints in winding insulation and thermal management, synchronous machines currently in operation, and those expected in new installations, could roughly be fitted in the ratings displayed in Table 3. This is the range of interest for the converter design.

Stator voltage range (line-to-line)	6-30kV
Stator current range (RMS)	2-8kA
Apparent power	80-400MVA

Multilevel converter scalability depends on the choice of basic building blocks. In very high power applications, it is preferable to design a converter using the so-called Power Electronic Building Blocks (PEBB), as for instance introduced in [25], [26]. A PEBB comprises power switches, accompanying control, communication and protection circuits.

Regarding semiconductor technology at high power levels, the use of „presspack“ housing could be beneficial, as in case of component fault, it safely fails to short-circuit state. The converter can continue the operation utilizing redundant submodules, providing high availability. Both IGBT and thyristor-based IGCT presspacks are available for kV voltage levels. While an advantage of IGBT may be higher attainable switching frequency, IGCT offers superiorly low on-state losses, with a limitation of lower switching frequencies. As can be shown, apparent switching frequency of an MMC arm, for phase-shifted carriers (PSC) modulation, equals (2):

$$f_{\text{apparent}} = N \cdot f_{\text{sw}} \quad (2)$$

where N represents number of submodules per converter arm, and f_{sw} equals submodule switching frequency. While (2) holds true for many forms of multilevel converters, an MMC has a considerably higher number of levels N . This means a satisfactory apparent frequency can be achieved with reduced submodule-level f_{sw} . Yet, in high power applications high switching frequencies are prohibitive due to thermal and efficiency constraints, and the use of Optimized Pulse Patterns (OPPs) or other fundamental switching methods is more likely [27].

A high power IGCT based PEBB has been introduced by ABB in [25], containing two submodules (cells) designated „type b“. Three more alternatives have been given, favouring either higher voltage or higher current

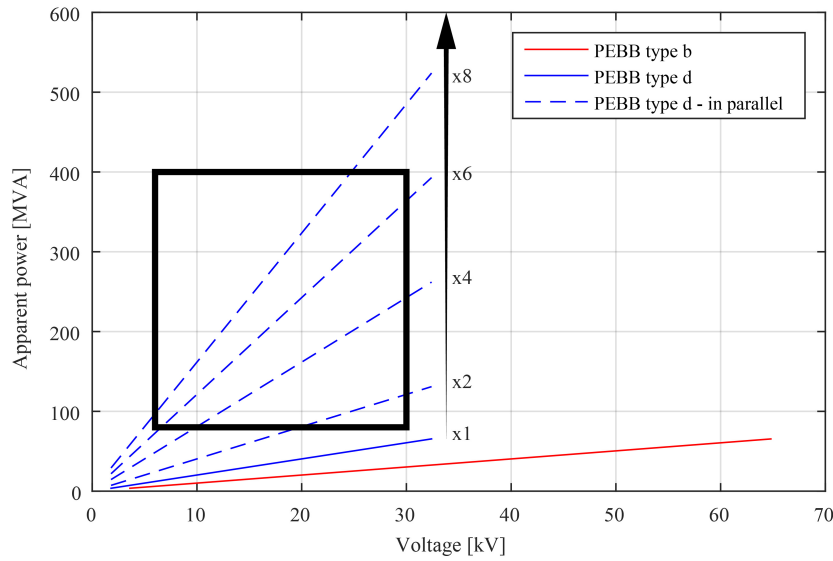

Fig. 4. Achievable power-voltage range of I-MMC using PEBB *b*, PEBB *d* and parallel PEBB *d* building blocks. The square represents PHSP range of interest

capability, while at fixed power rating. Based on data from [25], estimated rated DC link voltage and current rating of the cells are given in Table 4.

Table 4. Approximate submodule ratings, based on ABB proposal

Cell variant	DC link voltage	Current rating
a	5,0kV	420A
b	3,6kV	583A
c	2,5kV	840A
d	1,8kV	1167A

MMC can be scaled up in voltage to meet machine rated voltage by stacking submodules in series, and scaled up in current rating by connecting cells within an arm in parallel. Considering the aforementioned PEBBs, variants *b* and *d* have been considered for MMC PHSP application. Type *b* was chosen as a solution already implemented by ABB. With voltage being easily scalable in MMC in contrast to the current rating, PEBB type *d* was considered interesting as the modification option with highest current rating. Figure 4 shows achievable power-voltage range for PEBB *b* and PEBB *d*, as well as PHSP range of interest.

Since majority of the area of interest cannot be covered through the use of considered cells, parallel connection has also been investigated. Paralleling PEBBs steepens P(V) curve, bringing MMC solution to the desired application range. It can be noted that PEBB units aiming future PHSP applications should favour higher current ratings, as this enables operation with less PEBBs in parallel.

3.2 Indirect MMC or Direct MMC

As shown, MMC arm strings can be scaled to real-world PHSP ratings. Due to decentralized energy storage and rather different energy management in MMC compared to monolithic VSCs, some limitations are imposed on low frequency operation of these converters with variable-speed drives [28]. It has been shown that Indirect MMC can be implemented in control of drives with quadratic load, such is a pump. I-MMC enables use of either half-bridge or full-bridge submodules, with a total of 12 arms due to back-to-back configuration.

On the other hand, Direct MMC is regarded as suitable for low-speed high torque applications, owing to output current overload capability in low-frequency range, which can be in range of 200% of nominal. This feature enables high torque to be achieved at low speeds, starting from standstill [29]. In PHSP applications, this regime could be associated to pump start without dewatering, where there is instantaneous load to the machine from zero-speed. In contrast to I-MMC, Direct topology requires full-bridge cells to be used, while comprising lower arm count of nine for the whole converter.

4 PEL PHSP research platform

Apart from research in power electronics converters for CFMSM aided by computer modelling, Power Electronics Laboratory (PEL) of École Polytechnique Fédérale de Lausanne (EPFL) is commissioning a medium-voltage (MV) PHSP research platform. Figure 5 depicts principal layout of the system. In terms of installed power, it is a

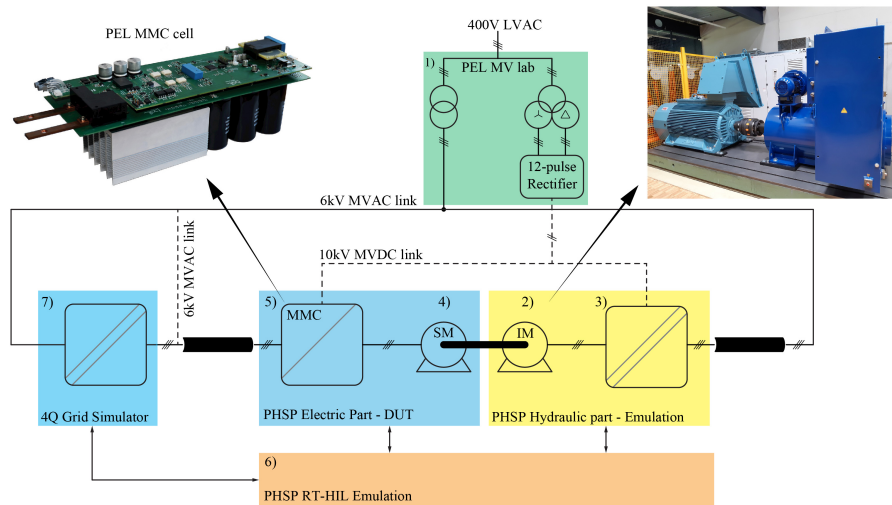

Fig. 5. Principal layout of PEL PHSP research platform: 1) MV laboratory grid, 2) induction machine, 3) industrial MV drive, 4) synchronous machine, 5) MMC converter, 6) HIL controller, 7) 4Q grid emulator

downscaled version of real-world systems, rated at 0,5MVA. In terms of voltage, however, it is in the range of some real-world plants, system voltage being 6kV line-to-line.

The setup is connected to MV grid of the laboratory, which supplies commercially available MV drive. The drive controls an induction machine (IM) that emulates turbine flow of a hydro power plant. A synchronous machine is controlled through an MMC. From this MMC point of view, grid is represented by a 4Q grid simulator, based on Robicon-type converter. The grid simulator can expose MMC output to various grid transients, e.g. voltage dips, asymmetries. The entire system is coordinated through real-time HIL for different real-world scenarios.

5 Conclusion

Pumped-storage power plants offer unrivalled high-volume energy storage performance. Introduction of power electronic converters for variable-speed operation augments flexibility of these plants to meet the demands of modern power systems. In this sense, CFMS configuration offers even higher flexibility over established DFIM. Emerging MMC topologies exhibit superior scalability compared to monolithic converters, and offer way forward in realization of high-power CFMS installations of the future.

References

- [1] V. Koritarov, T. Veselka, J. Gasper, and B. Bethke, "Modeling and Analysis of Value of Advanced Pumped Storage Hydropower in the United States," *Argonne Natl. Lab.*, vol. 1, 2014.
- [2] M. Valavi and A. Nysveen, "Variable-Speed Operation of Hydropower Plants," *IEEE Ind. Appl. Mag.*, vol. 24, no. 5, pp. 18–27, 2018.
- [3] C. J. Yang and R. B. Jackson, "Opportunities and barriers to pumped-hydro energy storage in the United States," *Renew. Sustain. Energy Rev.*, vol. 15, no. 1, pp. 839–844, 2011.
- [4] J. I. Pérez-Díaz, M. Chazarra, J. García-González, G. Cavazzini, and A. Stoppato, "Trends and challenges in the operation of pumped-storage hydropower plants," *Renew. Sustain. Energy Rev.*, vol. 44, pp. 767–784, 2015.
- [5] E. Ela, M. Milligan, and B. Kirby, "Operating Reserves and Variable Generation," 2011.
- [6] C. Weber, "Adequate intraday market design to enable the integration of wind energy into the European power systems," *Energy Policy*, vol. 38, no. 7, pp. 3155–3163, 2010.
- [7] H. Schlunegger and A. Thöni, "100 MW full-size converter in the Grimsel 2 pumped-storage plant," in *Hydro 2013 conference*, 2013.
- [8] R. Deb, "Operating Hydroelectric Plants and Pumped Storage Units in a Competitive Environment," vol. 6190, no. 00, pp. 24–32, 2000.
- [9] J. Pinto, J. De Sousa, and M. V. Neves, "The value of a pumping-hydro generator in a system with increasing integration of wind power," in *2011 8th International Conference on the European Energy Market, EEM 11*, 2011, no. May, pp. 306–311.
- [10] M. Chazarra, J. I. Perez-Diaz, and J. Garcia-Gonzalez, "Optimal Energy and Reserve Scheduling of Pumped-Storage Power Plants Considering Hydraulic Short-Circuit Operation," *IEEE Trans. Power Syst.*, vol. 32, no. 1, pp. 344–353, 2017.

- [11] D. Schafer and J. J. Simond, "Adjustable speed asynchronous machine in hydro power plants and its advantages for the electric grid stability," in *Cigre*, 1998.
- [12] A. Iwadachi, K. Tani, and K. Aguro, "The design of adjustable-speed pump-turbine modified from existing constant-speed on Okutataragi Power Station," *2016 19th Int. Conf. Electr. Mach. Syst.*, pp. 1–4, 2016.
- [13] "Adjustable Speed Pumped Storage Systems." [Online]. Available: <https://www.jase-w.eccj.or.jp/technologies/pdf/electricity/E-34.pdf>.
- [14] S. Furuya, T. Taguchi, K. Kusunoki, T. Yanagisawa, T. Kageyama, and T. Kanai, "Successful achievement in a variable speed pumped storage power system at Yagisawa power plant," *Power Convers. Conf.*, pp. 603–608, 1993.
- [15] "Connecting Water to Wire," 2016. [Online]. Available: http://www.gepowerconversion.com/sites/gepc/files/downloads/C_Connecting Water to Wire.pdf.
- [16] P. K. Steimer, O. Apeldoorn, B. Odegard, S. Bernet, and T. Bruckner, "Very high power IGBT PEBB technology," 2005, p. 11 pp.-P.11.
- [17] F. Kieferndorf, M. Basler, J. Fabian, and A. Coccia, "The five-level converter," *ABB Rev.*, vol. 11, no. 1, pp. 41–46, 2000.
- [18] J. Krenn, H. Keck, and M. Sallaberger, "Small and Mid-Size Pump-Turbines with Variable Speed," *Energy Power Eng.*, vol. 5, no. April, pp. 48–54, 2013.
- [19] P. K. Steimer, O. Senturk, S. Aubert, and S. Linder, "Converter-fed synchronous machine for pumped hydro storage plants," *2014 IEEE Energy Convers. Congr. Expo. ECCE 2014*, pp. 4561–4567, 2014.
- [20] "ACS6000 Medium Voltage Drive," 2018. [Online]. Available: <https://search-ext.abb.com/library/Download.aspx?DocumentID=3BHT 490 399 R0001&LanguageCode=en&DocumentPartId=&Action=Launch>.
- [21] "The Reliable Medium-Voltage Drive with IGBTs - SINAMICS GM150 and SM150 Medium-Voltage Drives," 2018. [Online]. Available: <https://w3app.siemens.com/mcms/infocenter/dokumentcenter/ld/InfocenterLanguagePacks/sinamics-gm150-sm150/ws-sinamics-sm150-gm150-igct-en.pdf>.
- [22] H. Schlunegger, "Pumping efficiency - A 100 MW converter for the Grimsel 2 pumped storage plant," *ABB Rev.*, vol. 14, no. 2, pp. 42–47, 2014.
- [23] A. Lesnicar and R. Marquardt, "An innovative modular multilevel converter topology suitable for a wide power range," *2003 IEEE Bol. PowerTech - Conf. Proc.*, vol. 3, pp. 272–277, 2003.
- [24] "More power for railway lines - Maximum efficiency with proven system behavior," *ABB Technology note - Rail SFC Light*. [Online]. Available: https://library.e.abb.com/public/991e03189b9548c2a423e57fc7dcb230/Rail SFC Light_tech note_RevC_EN.pdf.
- [25] T. Wikström and D. Weiss, "Rugged MMC converter cell for high power applications ABB SWITZERLAND Keywords MMC submodule design with IGBT semiconductors and bypass thyristor," *Power Electron. Appl. (EPE'16 ECCE Eur. 2016 18th Eur. Conf.)*, pp. 1–10, 2016.
- [26] D. Weiss, "IGBT-based modular multilevel converter for an AC-AC railway power supply," in *PCIM Europe*, 2017, pp. 153–160.
- [27] M. Vasiladiotis, A. Christe, T. Geyer, and A. Faulstich, "Decoupled Modulation Concept for Three-to-Single-Phase Direct AC / AC Modular Multilevel Converters for Railway Interties The decoupled modulation concept," pp. 1–9.
- [28] A. J. Korn, M. Winkelkemper, and P. Steimer, "Low output frequency operation of the Modular Multi-Level Converter," in *2010 IEEE Energy Conversion Congress and Exposition*, 2010, pp. 3993–3997.
- [29] W. Kawamura, M. Hagiwara, and H. Akagi, "Experimental verification of a modular multilevel cascade converter based on triple-star bridge-cells (MMCC-TSBC) for motor drives," in *Future Energy Electronics Conference (IFEEC), 2013 1st International*, 2013, pp. 454–459.

The Authors

Miodrag Basić was born in Belgrade, Serbia, in 1990. He received the BSc and MSc degrees in Electrical and Computer Engineering from the School of Electrical engineering, University of Belgrade, Serbia, respectively in 2013 and 2015. During and after graduation, he had spent three years in industrial automation, as a design and commissioning engineer on industrial projects involving large AC drives. Since 2017, he has been with the Power Electronics Laboratory of École Polytechnique Fédérale de Lausanne (EPFL), Lausanne, Switzerland, pursuing the PhD degree. His research interests are predominantly based around multilevel conversion systems for high-power medium-voltage applications.

Pedro C. O. Silva received the Dipl.-Ing. degree in electrical engineering from the Federal University of Itajubá, Brazil, in 2006, and the MSc and Ph.D. degrees from the École Polytechnique Fédérale de Lausanne (EPFL), Lausanne, Switzerland, in 2009 and 2015, respectively. His employment experiences have been in the field of hydroelectric power generation. He is currently with EPFL, Lausanne, Switzerland, as a Postdoctoral Researcher in the Power Electronics Laboratory. His research interests include hydropower plants and high-power electronics applied to pumped storage power plants.

Dražen Dujčić is an Assistant Professor and Head of the Power Electronics Laboratory at EPFL, Lausanne, Switzerland. He received the Dipl. Ing. and MSc degrees from the University of Novi Sad, Novi Sad, Serbia in 2002 and 2005, respectively, and the PhD degree from Liverpool John Moores University, Liverpool. His research interests include the areas of design and control of advanced high power electronic systems and high-performance drives, predominantly for the medium voltage applications related to electrical energy generation, conversion and storage.