

© 2018 IEEE

24th International Conference on Electrical Engineering - ICEE; Proceedings of

Review of Protection Coordination Technologies in DC Distribution Systems

S. Kim, D. Dujic, Y. Park, *et al.*

This material is posted here with permission of the IEEE. Such permission of the IEEE does not in any way imply IEEE endorsement of any of EPFL's products or services. Internal or personal use of this material is permitted. However, permission to reprint / republish this material for advertising or promotional purposes or for creating new collective works for resale or redistribution must be obtained from the IEEE by writing to pubs-permissions@ieee.org. By choosing to view this document, you agree to all provisions of the copyright laws protecting it.

Review of Protection Coordination Technologies in DC Distribution Systems

Seongil Kim[†], Drazen Dujic^{*}, Youngho Park^{**}, and Soo-Nam Kim^{**}

Abstract – With the evolution of power electronics technologies, DC networks have been considered as promising distribution systems for future grids. This new concept of power systems comes with technical challenges in protection coordination, a result of the no natural current zero-crossing point and very low thermal capacity of semiconductors in power converters. In order to overcome this technological barrier, many researches have been conducted. This paper presents a summary of the state-of-the-art on protection coordination technologies in DC distribution systems considering whole DC protection procedure: fault detection, fault localization, fault isolation and backup protection. In addition, two different protection schemes for low-voltage DC (LVDC) shipboard power systems (SPS) which are commercially viable measures are described.

Keywords: Protection coordination, DC distribution systems, DC fault, Fault detection, Fault localization, Fault isolation, Backup protection, DC shipboard power systems

1. Introduction

DC distribution systems are considered as a promising solution for many applications, such as rural residential loads (long-distance low-voltage distribution lines), offshore wind park integration, and stand-alone power systems [1]-[5]. Especially, this technology has rapidly been employed in a marine domain due to its main benefits: high fuel efficiency with variable-speed engines, better integration of energy storage systems, weight and footprint savings by removing bulky transformers, elimination of reactive power flow, and easier connection of power sources without need for frequency synchronization [6]-[8].

This new concept of power systems comes with technical challenges in protection coordination, a result of the no natural current zero-crossing [9] and very low thermal capacity of semiconductors in power converters [10].

In AC which periodically reverses its direction with sinusoidal waveforms, the interruption of fault currents occurs at the current zero-crossing. Whilst there is no polarity change in the DC current, this makes the development of DC circuit breakers (CB) difficult or costly compared to mechanical AC CBs. Fig. 1 depicts an example of AC and DC fault currents for a DC line-to-line fault and shows their typical time evolution.

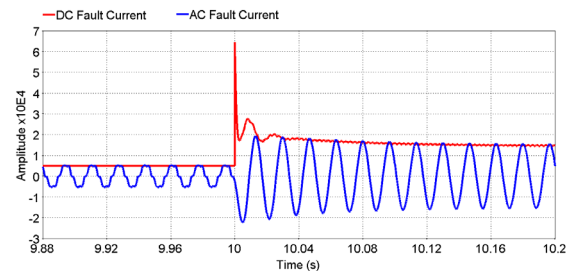

Fig. 1. AC and DC fault currents for DC line-to-line fault

Additionally, the semiconductors in power converters have much lower thermal capabilities than other power equipment such as generators and transformers, as shown in Fig. 2. It means that a fault in the DC network has to be cleared much faster than that in the AC network.

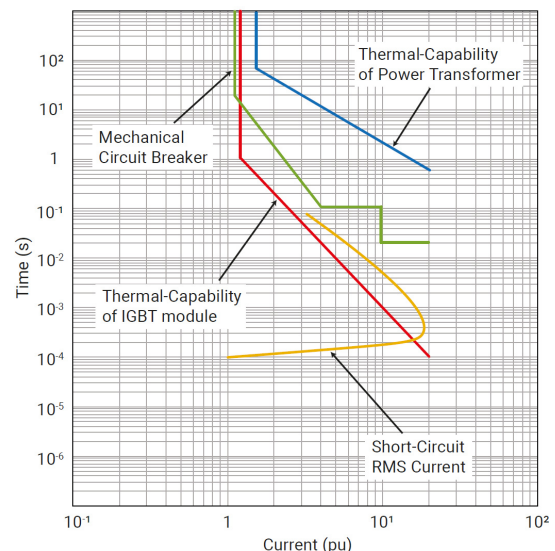

Fig. 2. Thermal capability comparison

[†] Corresponding Author : Power Electronics Laboratory, École Polytechnique Fédérale de Lausanne (EPFL), Switzerland (seongil.kim@epfl.ch)

^{*} Power Electronics Laboratory, École Polytechnique Fédérale de Lausanne (EPFL), Switzerland (drazen.dujic@epfl.ch)

^{**} Power Control Research Dept., Hyundai Electric & Energy Systems, Republic of Korea (park.youngho@hyundai-electric.com, kimsoonam@hyundai-electric.com)

With the interest generated by DC distribution systems, various methods have been proposed for each DC protection process to find feasible protection measures. This paper provides brief overview of the state-of-the-art of protection coordination technologies for DC distribution systems. Furthermore, protection schemes for two commercial LVDC SPSs are also presented.

2. State-of-the-Art of DC Protection Coordination

The general procedure of DC power system protection is illustrated in Fig. 3. When a fault occurs in the DC networks, it has to be detected to distinguish faults from normal transient conditions. Fault localization is essential to continuously supply electric power to healthy parts by selectively isolating faulty parts. The protection system with fault-limiting devices such as circuit breakers, fuses and fault limiters should rapidly interrupt faults to prevent damage to any other equipment. Backup protection should be considered in case of a primary protection failure to increase the reliability of the protection system.

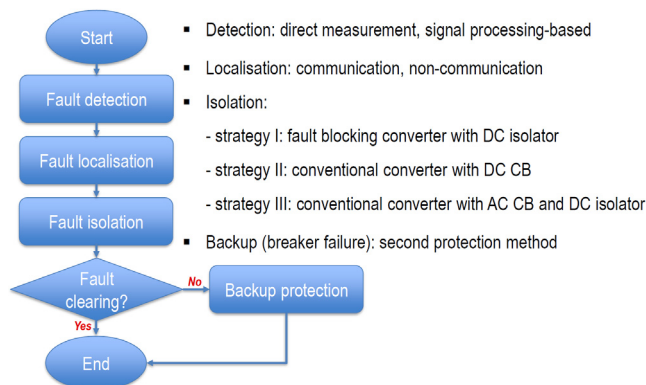

Fig. 3. Procedure of DC power system protection

2.1 Fault Detection

There are two main categories for the fault protection: direct measurement methods and signal processing-based methods, as shown in Table 1. A system fault is characterized by an increase in current and a decrease in voltage [11], and the current flow might be different from normal conditions depending on fault locations [12]. The first category directly uses the characteristics of measured voltage and current such as their amplitudes, derivatives and directions. These methods provide high detecting speed with fewer computational resources. They, however, offer little selectivity for the DC protection. The second is based on signal processing techniques like wavelet analysis and travelling wave analysis. According to [13]–[18], although

the signal processing-based methods offer higher accuracy in fault detecting and localizing than the direct technique, they have some drawbacks like high computational time and implementation complexity.

Table 1. Fault detection techniques

| Category | Fault Detection |
|-------------------------|---|
| Direct measurement | Under-voltage (amplitude) [11] Voltage & current derivatives [14] Over-current (amplitude) [19] Current difference (or direction) [12] Impedance (or distance) [20] |
| Signal processing-based | Wavelet analysis [13] Travelling-wave analysis [15] |

2.2 Fault Localization

Fault localization is necessary for minimizing the impact from the fault by removing a faulty part. Communication-based localization (Fig. 4(a)), which has been reported to provide high accuracy in fault locating, is based on data transfer between several adjacent local relays or data gathering into a central controller [21], [22]. It is therefore not possible to avoid a certain amount of time delay. Non-communication measures rapidly operate local CBs when measured signals are higher than preselected thresholds. In this method, fault localization between different protection zones is given by selecting different operating times depending on amplitudes of fault current, voltage dip, or impedance [23], as shown in Fig. 4(b).

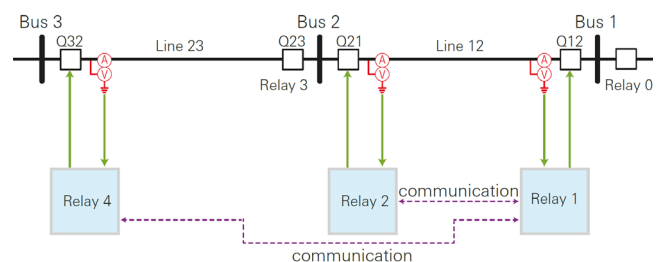

(a) Communication-based [22]

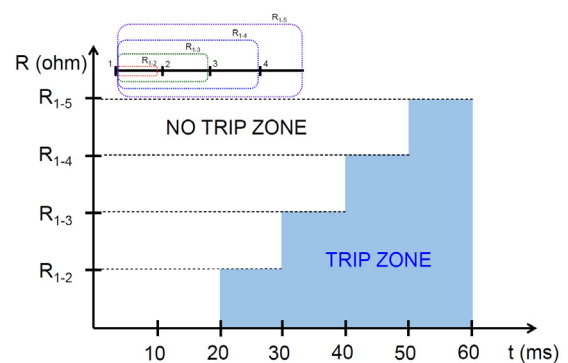

(b) Non-communication [23]

Fig. 4. Fault localization techniques

However, these time-inverse methods cannot provide a selective coordination by the use of conventional protective devices due to low DC cable impedance and fast fault-clearing requirement.

2.3 Fault Isolation

The isolation methods are classified into three groups: (a) fault-blocking converter with DC isolator, (b) conventional converter with AC CB and (c) conventional converter with DC CB. The fault-blocking converter, like the full-bridge modular multi-level converter shown in Fig. 5(a), can handle the fault current by itself without any circuit breakers, if full-bridge cells are used. The disadvantages of the fault-blocking converter are its high cost and high conduction loss.

The approach by means of the conventional converter with AC CB is proposed in [18]. This method, however, is needed to install very high reactance on the AC-side (L_f in Fig. 5(b)) to reduce the amplitude of a fault current that allows for use of the relatively slow AC CB. The reactor on the AC-side generates conduction loss, and makes the grid weak.

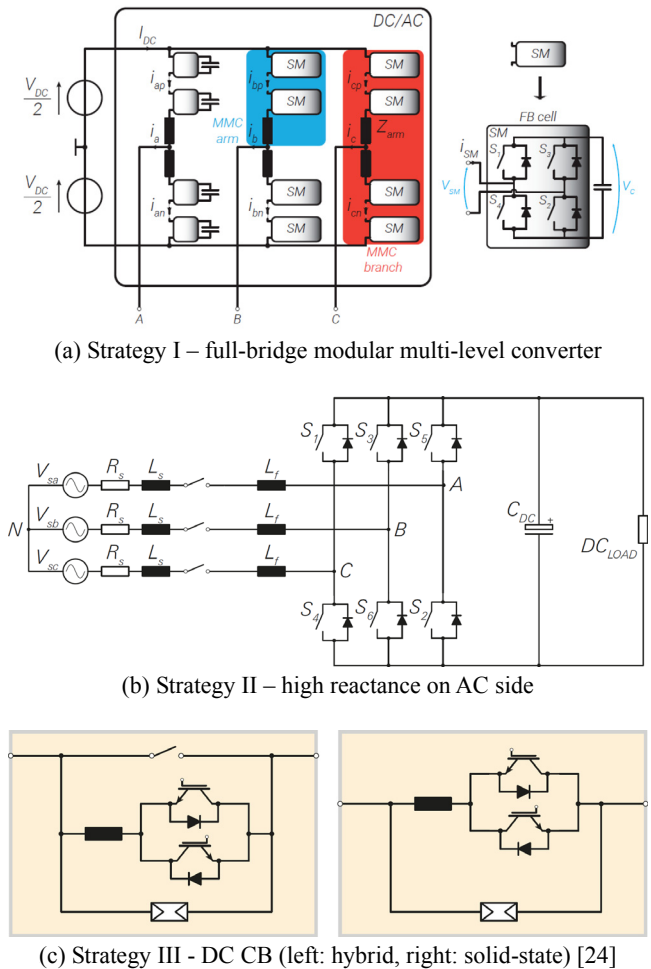

Fig. 5. Fault isolation methods

As a last approach for the isolation, the conventional converter with DC CB can be a feasible combination. With very fast operation speed of the DC CB, this solution can isolate a system fault from the system within a few milliseconds. A lot of researches have been conducted for developing a hybrid (a mechanical circuit breaker combined with solid-state technology, Fig. 5(c) left) and a solid-state DC CB (Fig. 5(c) right). Nevertheless, they are still in the development stage due to difficulties in the no zero-crossing and high thermal energy handling.

2.4 Backup Protection

Backup protection must be considered in case of the failure of the primary protection. In order to prevent the abnormal operation of the backup protection, a time margin Δt_{pb} in Fig. 6(a) between the primary and the backup protections has been used in the AC network [25]. But, for the DC network, such a time margin can lead to undesired equipment failures.

In [26], a detecting algorithm for the primary protection failure is proposed, and it can instantly identify the non-operation of the primary action by observing impedance changes from the fault inception to the primary fault clearing time. This new approach can reduce the fault clearance time, as represented in Fig. 6(b), but it is still needed to verify its effectiveness for various types of faults and fault resistances.

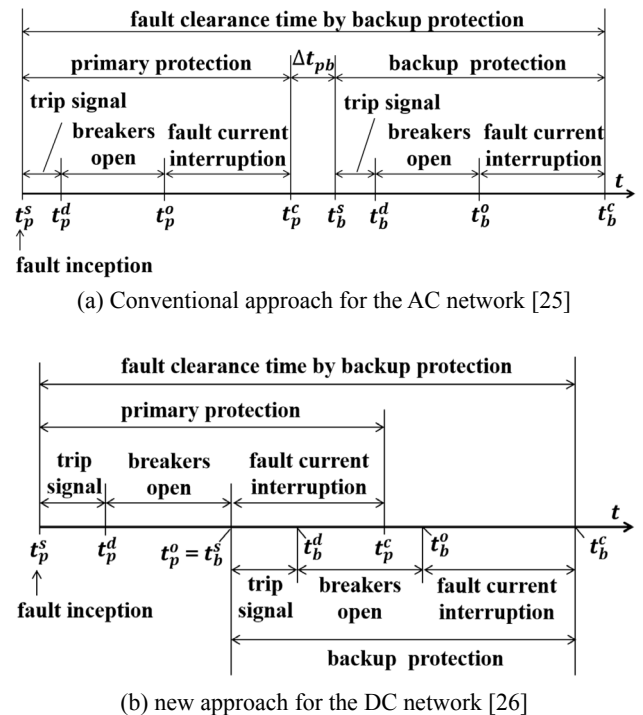

Fig. 6. Fault clearance time by backup protection

3. Protection Schemes for LVDC SPS

Various marine LVDC solutions were introduced and have commercially been applied to dynamic positioning vessels (e.g. platform supply vessels and shuttle tankers) with power levels up to 20 MW and a nominal DC voltage level of 1 kV [3], [4]. Fig. 7 illustrates a general schematic of the LVDC SPS. It consists of power generating units (a generator set with a rectifier), hotel loads, large motors, thrusters, energy storage systems and a bus tie breaker.

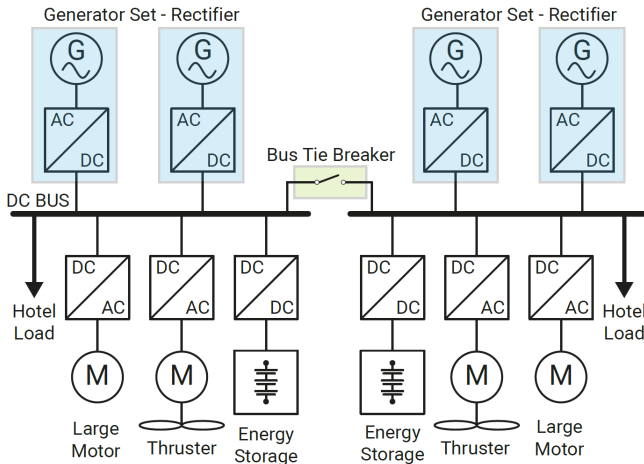

Fig. 7. General schematic of LVDC SPS

The LVDC ships have employed different protection schemes according to rectifier types. In this paper, the protection schemes for the LVDC SPSs based on a diode rectifier and a thyristor rectifier are described, as these systems are already in commercial use.

3.1 Diode Rectifier-Based LVDC SPS

The power generation part proposed by [3] consists of a generator set and a diode rectifier, as shown in Fig. 8. A protection scheme for the diode rectifier based-LVDC SPS uses the combination of a bus-tie breaker, relatively high sub-transient reactance of a synchronous machine, excitation removal and a semiconductor fuse.

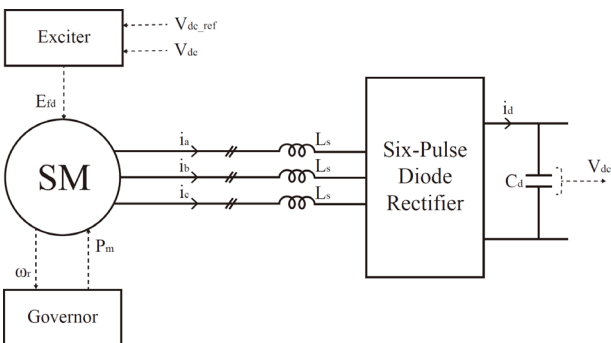

Fig. 8. Generator set with diode rectifier [27]

For the main DC bus fault, the bus-tie breaker in Fig. 7 autonomously disconnects each bus within 50 μ s [3]. With this operation, the faulty bus is disconnected from the system, and then the voltage in the healthy part is ramped up again. In the faulty part, the fault current from the generator is limited by the high sub-transient reactance, and then a generator protection unit in the generator trips the generator excitation controller to decay the fault current to zero. It takes a few seconds to completely eliminate the fault current with the excitation removal method. To avoid any device damage, the thermal capacity of the rectifier should carefully be designed to sustain the fault energy for such a long period of time.

In this protection scheme, feeder faults which occur at load feeders are cleared by semiconductor fuses. In addition, the selective operation of the semiconductor fuses are also considered to minimize the impact of the faults.

3.2 Thyristor Rectifier-Based LVDC SPS

In [28], the thyristor rectifier-based LVDC SPS (its power generation part is shown in Fig. 9) is introduced with its protection scheme. This LVDC SPS is divided into two parts: a power generating unit (a generator set and a thyristor rectifier) and a drive unit (an inverter and an asynchronous machine or a hotel load). Protection devices in this system consist of a DC isolator, a bus tie breaker, a fuse and a controllable rectifier.

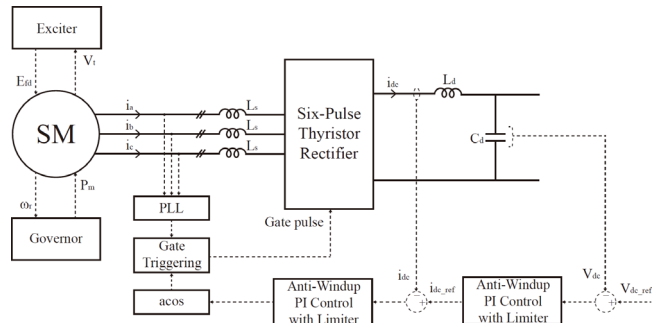

Fig. 9. Generator set with thyristor rectifier [29]

In case of the main DC bus fault, the bus tie breaker isolates the faulty section, and then it makes the healthy party self-sustainable. The thyristor rectifier in the faulty area generates negative DC output voltage to interrupt the fault current by controlling the firing angle, called a fold-back protection control. In the scheme, any fault currents can be cleared within maximum 40 ms [3]. Further advanced control scheme, active fault-current fold-back control, is proposed to reduce the fault clearing time in [30].

The feeder faults in the protection scheme are also handled by the semiconductor fuse.

4. Conclusion

This paper briefly presented the protection coordination technologies in DC distribution systems with their pros and cons. For the whole protection procedure, a lot of techniques have been proposed to employ the DC systems into the conventional AC systems. However, there is a lack of comprehensive studies on the DC protection considering the whole procedure and different DC systems. In addition, in aspects of equipment and system, the DC CB is at an early development stage and there is no typical DC distribution systems as well as international standards on the protection.

As a second part in this paper, two commercial protection schemes for the LVDC SPS were discussed. Both schemes manage the fault currents without any breakers. But, these schemes are only applicable to low-voltage and limited power capacity of the DC SPS. Considering the demand of the DC SPS, it is expected that protection schemes for high-power medium-voltage SPSs will be developed in near future.

Acknowledgements

This work was supported by Hyundai Electric & Energy Systems Co., LTD., Republic of Korea.

References

- [1] J. Lassila, T. Kaipia, J. Haakana, J. Partanen and K. Koivuranta, "Potential and strategic role of power electronics in electricity distribution systems," *CIGRE 2009 - 20th International Conference and Exhibition on Electricity Distribution - Part 1*, Prague, Czech Republic, 2009, pp. 1-5.
- [2] B. Ravi, S. Raval, V. R. R. Rudraraju and C. Nagamani, "Performance analysis of MVAC and MVDC offshore wind farm distribution system using direct load flow method," *2016 2nd International Conference on Advances in Electrical, Electronics, Information, Communication and Bio-Informatics (AEEICB)*, Chennai, 2016, pp. 341-346.
- [3] J. F. Hansen, J. O. Lindtjørn, and K. Vanska, "Onboard DC Grid for enhanced DP operation in ships," in *Dynamic Positioning Conference*, Houston, 2011.
- [4] S. O. Settemsdal, E. Haugan, K. Aagesen, and B. Zahedi, "New Enhanced Safety Power Plant Solution for DP Vessels Operated in Closed Ring configuration," in *Dynamic Positioning Conference*, 2014.
- [5] U. Javaid, D. Dujic and W. van der Merwe, "MVDC marine electrical distribution: Are we ready?," *IECON 2015 - 41st Annual Conference of the IEEE Industrial Electronics Society*, Yokohama, 2015, pp. 823-828.
- [6] Z. Jin, G. Sulligoi, R. Cuzner, L. Meng, J. C. Vasquez, and J. M. Guerrero, "Next-generation shipboard dc power system: Introduction smart grid and dc microgrid technologies into maritime electrical networks," *IEEE Electrification Magazine*, vol. 4, no. 2, pp. 45-57, 2016.
- [7] R. Prenc, A. Cuculić, and I. Baumgartner, "Advantages of using a dc power system on board ship," *Pomorski zbornik*, vol. 52, no. 1, pp. 83-97, 2016.
- [8] B. Zahedi, L. E. Norum, and K. B. Ludvigsen, "Optimized efficiency of all-electric ships by dc hybrid power systems," *Journal of Power Sources*, vol. 255, no. Supplement C, pp. 341-354, 2014.
- [9] P. Cairoli and R. A. Dougal, "New horizons in dc shipboard power systems: New fault protection strategies are essential to the adoption of dc power systems," *IEEE Electrification Magazine*, vol. 1, no. 2, pp. 38-45, 2013.
- [10] Z. Miao, G. Sabui, A. M. Roshandeh, and Z. J. Shen, "Design and analysis of dc solid-state circuit breakers using SiC JFETs," *IEEE Journal of Emerging and Selected Topics in Power Electronics*, vol. 4, no. 3, pp. 863-873, 2016.
- [11] D. Salomonsson, L. Soder, and A. Sannino, "Protection of low-voltage dc microgrids," *IEEE Transactions on Power Delivery*, vol. 24, no. 3, pp. 1045-1053, 2009.
- [12] K. Satpathi, N. Thukral, A. Ukil, and M. A. Zagrodnik, "Directional protection scheme for mvdc shipboard power system," in *IECON 2016 - 42nd Annual Conference of the IEEE Industrial Electronics Society*, 2016, pp. 3840-3847.
- [13] K. D. Kerf, K. Srivastava, M. Reza, D. Bekaert, S. Cole, D. V. Hertem, and R. Belmans, "Wavelet-based protection strategy for dc faults in multi-terminal vsc hvdc systems," *IET Generation, Transmission Distribution*, vol. 5, no. 4, pp. 496-503, 2011.
- [14] E. Martinsen, "Evaluation of methods for detecting and locating faults in hvdc grids," Master's thesis, Institutt for elkraftteknikk, 2014.
- [15] Y. M. Yeap and A. Ukil, "Wavelet based fault analysis in hvdc system," in *IECON 2014 - 40th Annual Conference of the IEEE Industrial Electronics Society*, 2014, pp. 2472-2478.
- [16] K. A. Saleh, A. Hooshyar, and E. F. El-Saadany, "Ultra-high-speed travelling-wave-based protection scheme for medium-voltage dc microgrids," *IEEE Transactions on Smart Grid*, vol. PP, no. 99, pp. 1-1, 2017.
- [17] E. O. Schweitzer, A. Guzman, M. V. Mynam, V. Skendzic, B. Kasztenny, and S. Marx, "Protective relays with traveling wave technology revolutionize fault locating," *IEEE Power and Energy Magazine*, vol. 14, no. 2, pp. 114-120, 2016.
- [18] S. Lu, "Dc cable short circuit fault protection in vsc-mtdc," Master's thesis, Delft University of Technology, 2015.
- [19] R. E. Torres-Olguin and H. K. Hoidalén, "Inverse time overcurrent protection scheme for fault location in multi-terminal hvdc," in *2015 IEEE Eindhoven PowerTech*, 2015, pp. 1-6.
- [20] E. Christopher, M. Sumner, D. Thomas, and F. de Wildt, "Fault location for a dc zonal electrical distribution

systems using active impedance estimation,” in *2011 IEEE Electric Ship Technologies Symposium*, 2011.

- [21] A. Maqsood and K. A. Corzine, “The z-source breaker for ship power system protection,” in *2015 IEEE Electric Ship Technologies Symposium (ESTS)*, 2015.
- [22] M. Monadi, C. Gavriluta, J. I. Candela, and P. Rodriguez, “A communication-assisted protection for mvdc distribution systems with distributed generation,” in *2015 IEEE Power Energy Society General Meeting*, 2015.
- [23] P. Cairoli and R. A. Dougal, “Fault Detection and Isolation in Medium-Voltage DC Microgrids: Coordination Between Supply Power Converters and Bus Contactors,” in *IEEE Transactions on Power Electronics*, vol. 33, no. 5, pp. 4535–4546, May 2018.
- [24] C. Meyer, M. Kowal, and R. W. D. Doncker, “Circuit breaker concepts for future high-power dc-applications,” in *Fourtieth IAS Annual Meeting*, 2005.
- [25] W. A. Elmore, *Protective relaying: theory and applications*. CRC press, 2003, vol. 1.
- [26] W. Leterme, S. P. Azad, and D. V. Hertem, “A local backup protection algorithm for hvdc grids,” *IEEE Transactions on Power Delivery*, vol. 31, no. 4, pp. 1767–1775, 2016.
- [27] U. Javaid, F. D. Freijedo, D. Dujic and W. van der Merwe, “Dynamic Assessment of Source–Load Interactions in Marine MVDC Distribution,” in *IEEE Transactions on Industrial Electronics*, vol. 64, no. 6, pp. 4372–4381, June 2017.
- [28] J. Lindtjoern, “A dc-power system with system protection capabilities,” EP Patent 2,634,885, 2015.
- [29] S. Kim, D. Dujic, and S.-N Kim, “Protection schemes in low-voltage dc shipboard systems,” in *PCIM Europe 2018; International Exhibition and Conference for Power Electronics, Intelligent Motion, Renewable Energy and Energy Management*, 2018, 1–5 (Accepted).
- [30] D. Dong, Y. Pan, R. Lai, X. Wu, and K. Weeber, “Active fault-current foldback control in thyristor rectifier for dc shipboard electrical system,” *IEEE Journal of Emerging and Selected Topics in Power Electronics*, vol. 5, no. 1, pp. 203–212, 2017.



Seongil Kim

Seongil Kim received the B.Sc and M.Sc. degrees from Hanyang University, Republic of Korea, in 2005 and 2007, respectively. Since 2007, he has been with the Hyundai Electric & Energy Systems Research Centre, Yongin, Republic of Korea, as a Senior Researcher in power system and high voltage technologies. In 2017, he joined the Power Electronics Laboratory at École Polytechnique Fédérale de Lausanne (EPFL), Switzerland, as a full-time Doctoral Assistant. His current research interests include the areas of design and protection of DC shipboard power systems.



Drazen Dujic

Drazen Dujic received the Dipl.-Ing. and M.Sc. degrees from the University of Novi Sad, Novi Sad, Serbia, in 2002 and 2005, respectively, and the Ph.D. degree from the Liverpool John Moores University, Liverpool, U.K., in 2008, all in electrical engineering. From 2002 to 2006, he was with the Department of Electrical Engineering, University of Novi Sad as a Research Assistant, and from 2006 to 2009 with Liverpool John Moores University as a Research Associate. From 2009 till 2013, he was with ABB Corporate Research Centre, Switzerland, as a Principal Scientist working on the power electronics projects spanning the range from low-voltage/power SMPS in below kilowatt range to medium voltage high-power converters in a megawatt range. During 2010–2011, he was a member of a project team responsible for the development of the world’s first power electronic traction transformer (PETT) successfully commissioned on the locomotive. From 2013 till 2014, he was with ABB Medium Voltage Drives, Turgi, Switzerland, as R&D Platform Manager, responsible for ABB’s largest IGCT based medium voltage drive - ACS6000. He is currently with École Polytechnique Fédérale de Lausanne (EPFL), Lausanne, Switzerland, as an Assistant Professor and the Director of the Power Electronics Laboratory. His current research interests include the areas of design and control of advanced high-power electronics systems and high performance drives. He has authored or coauthored more than 80 scientific publications and has filed eleven patents. He is an Associate Editor for *IEEE Transactions on Industrial Electronics*, *IEEE Transaction on Power Electronics* and *IET Electric Power Applications*.



Youngho Park

Youngho Park received the B.Sc degree from Korea Advanced Institute of Science and Technology (KAIST), Daejeon, Republic of Korea, in 2005, and the M.Sc degree from Seoul National University, Seoul, Republic of Korea in 2007. Since 2008, he has been with Hyundai Electric & Energy Systems Research Centre, Yongin, Republic of Korea, as a Senior Researcher in power system and power electronics technologies.



Soo-Nam Kim

Soo-Nam Kim received the B.Sc, M.Sc, and Ph.D. degrees from Hanyang University, Republic of Korea, in 1996, 1998, and 2003, respectively. Since 2003, he has been with Hyundai Electric & Energy Systems Research Centre, Yongin, Republic of Korea, as a Senior Researcher in power system and control technologies, and is currently leading the Power Control Research Department.