

PAT-OK  
PC-OK

## Chapter 15

# Rainwater capture and irrigation

The semi-arid tropics of Brazil cover an area of 1 150 000 km<sup>2</sup>, which corresponds to 70 percent of the region in the Northeast and 13 percent of the country. There is a diverse range of climates, made up of 120 geo-environmental units with large differences as regards their physical, biological and socio-economic characteristics (Silva *et al.* 1993). The limiting factors governing agricultural development in the region comprise, amongst others, a general shortage or poor distribution of the rains, soil limitations and the agricultural practices used.

The soils predominating in the region are of a crystalline origin, normally flat, siliceous and stony, with low infiltration capacity and low organic matter content. Coupled with these characteristics, the high rainfall intensity causes water losses due to runoff and consequent water erosion. Given the characteristics of the region and when planning at farm level, it is convenient to consider minimum risk mechanisms for exploitation which allow satisfactory production, despite the limiting environmental conditions.

Various rainwater harvesting methods using animal traction as the power source have been developed and adopted through the work of EMBRAPA, the Brazilian Enterprise for Agricultural and Livestock Research, based at CPATSA, the Centre for Agricultural and Livestock Research in the Semi-Arid Tropics. The main rainwater harvesting techniques that have proven appropriate for the production conditions of the Brazilian semi-arid zone are presented in this chapter.

### PRINCIPAL FACTORS AFFECTING THE ESTABLISHMENT OF SYSTEMS FOR RAINWATER CAPTURE

In order to establish an *in situ* rainwater capture system, information is required concerning a number of factors such as the area to be cultivated, the soil, the topography, the amount and distribution of the rainfall, the crops (annual and perennial) and the availability of equipment and labour. These factors must then be weighed against the socio-economic factors in order to establish the feasibility for investment in the technology.

Rainfall in the municipality of Petrolina, PE, is concentrated in the months from December to April, which is considered to be the agricultural season. Study of the rainfall data over a ten-year

*J. Barbosa dos Anjos, L. Teixeira de Lima Brito and M.S. Lopes da Silva  
Brazilian Enterprise for Agricultural and Livestock Research (EMBRAPA)  
Centre for Agricultural and Livestock Research in the Semi-arid Tropics (CPATSA)  
Petrolina, Brazil*

period (1985 – 1994) shows a wide variation but in six years out of ten, a concentration of the rainfall in the month of March (Table 36).

TABLE 36  
Monthly rainfall recorded at Petrolina, PE, Brazil for the period 1985 – 1994

Month	Year									
	1985	1986	1987	1988	1989	1990	1991	1992	1993	1994
Jan	286.6	36.5	4.8	99.2	27.5	34.2	103.0	344.1	34.4	121.4
Feb	84.9	78.5	30.7	31.7	21.0	90.3	111.2	122.1	12.0	41.0
Mar	172.0	184.1	162.8	256.8	216.7	25.7	207.4	49.4	5.5	156.5
Apr	151.6	25.1	19.8	117.3	154.6	42.8	47.6	33.4	20.8	78.4
May	15.6	14.0	73.3	29.8	78.5	6.6	52.7	4.0	3.8	5.9
Jun	69.9	0.8	0.8	44.9	0.0	9.0	21.8	4.0	5.9	9.9
Jul	5.6	7.7	47.4	5.9	14.1	61.6	0.0	0.9	1.4	14.8
Aug	19.9	1.3	0.0	0.0	5.4	0.3	4.3	0.0	5.8	0.0
Sep	0.0	0.6	0.0	0.0	0.0	0.4	0.0	0.9	0.8	1.0
Oct	3.4	3.6	54.6	14.4	0.0	0.0	0.0	0.0	25.7	0.0
Nov	95.1	3.3	0.0	56.1	6.2	61.3	73.3	31.9	55.5	0.0
Dec	174.0	29.5	12.8	105.0	369.3	18.8	13.1	68.1	16.2	42.2
Total	1 078.6	385.1	407.0	761.1	893.3	351.0	634.8	658.8	187.8	471.1

The sowing date is another factor of extreme importance for the success of dryland agriculture. It has been shown that the best sowing date for cowpea in the municipality of Petrolina, PE, is from March 2 to 6 and for maize, from January 17 to February 9, which coincides with the season of the greatest concentration of rainfall (Silva *et. al*, 1982).

Soil erosion is most affected by the rainfall characteristics, particularly its intensity. In the semi-arid zone of Brazil, the rainfall pattern is characterized by storms of high intensity and short duration, with tillage often being undertaken when moisture conditions are inadequate, causing soil pulverization which consequently makes it more vulnerable to erosion. According to Lopes and Brito (1993), the most critical period for the erosivity of the rainfall is from February to April when almost two-thirds of the total annual erosivity occurs.

Maize cultivation (*Zea mays L.*) requires between 500 and 800 mm of water well distributed throughout the growth phases, without considering other factors affecting its production (FAO, 1979). The stages of flowering and of grain filling are critical for obtaining maximum production.

In conditions with an average rainfall of about 400 mm, it was observed that annually, a moisture deficit occurs due mainly to the irregularity of the rainfall distribution both in timing and the spacing between showers or storms.

#### METHODS FOR *IN SITU* RAINFALL CAPTURE

The traditional system of minimum tillage in pockets using a hoe, causes a small depression which is capable of storing a certain amount of rainwater. This system is not apparently very aggressive to the environment but, as the soil is not ploughed, the surface appears slightly compacted which makes infiltration difficult and encourages runoff and so contributes to the erosive process. It is therefore necessary to use simple soil preparation techniques for the *in situ* capture of the rainwater, which may be undertaken using either motorized power or animal traction (Duret *et al.*, 1986).



### ***In situ* capture of rainwater: ploughing and planting on flat land**

Ploughing the soil for establishing dryland crops in the semi-arid north-eastern region of Brazil constitutes one of the *in situ* rainwater capture techniques used in the area. The shaping of small depressions due to the ploughing operation has the objective of impeding surface runoff of the rainwater so that it remains stored in the soil and so available to the crop for a longer period. This system consists of using tractor or animal drawn ploughs, an animal drawn mouldboard plough offering the simplest solution (Anjos, 1985). Figure 49 shows a schematic representation of the crop in the field.

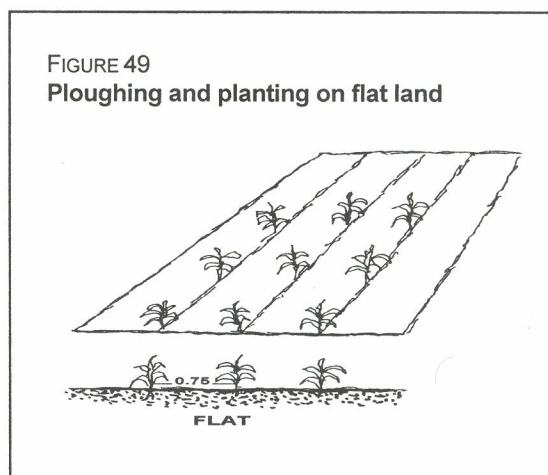

For animal traction, the simplest equipment consists of a mouldboard plough with an 8 inch (0.20 m) working width. It costs approximately US\$ 150 and the work animal is valued at around US\$ 300, meaning a total investment cost of US\$ 450. Hire costs for the same implement and the animal amount to US\$ 0.96/h. Using a tractor, the hire costs for a wheeled tractor with a plough vary between US\$ 12 and 15/h.

### ***In situ* capture of rainwater: ridging after planting**

Ridging after planting is a rainwater harvesting technique that consists of ploughing and sowing the flat area followed by ridging between the crop rows and ridging up again a second and third time according to the crop, using either animal drawn or tractor operated ridgers (Figure 50). When crops such as maize and sorghum are well developed, it becomes difficult to use the toolbar equipped with more than a single ridger body. The solution lies in using a single animal to pull a one-row ridger body along the row.

The most appropriate time for ridging cowpea is 20 to 30 days after planting and for maize, 30 to 40 days after planting.

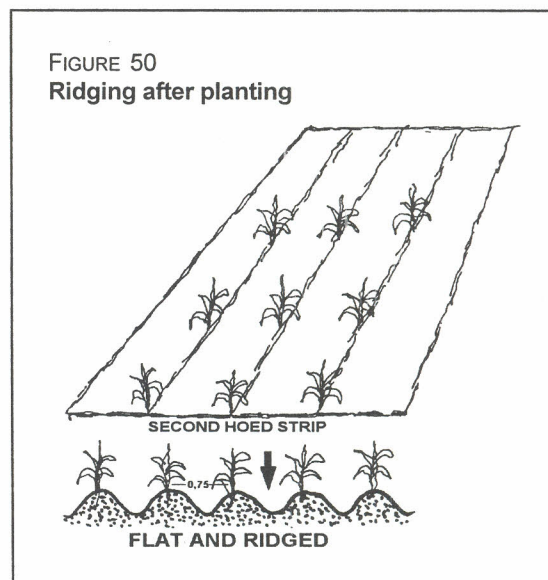

The cost of an animal drawn ridger is approximately US\$ 80, which when added to the animal cost of US\$ 300, gives a total investment cost of US\$ 380. Hire costs for the same implement and the animal amount to US\$ 0.90/h. To hire a tractor, the costs for a wheeled tractor with a plough vary between US\$ 12 and 15/h.

### ***In situ* capture of rainwater: ridging before planting**

The technique of *in situ* rainwater harvesting by ridging before planting consists of ploughing the area and then opening up furrows at 0.75 m row spacing. For this system, hoeing is accomplished by ridging along the rows and then using a handhoe to hoe between the plants.

This system, owing to the ridge defining the line of planting (Figure 51), allows better use of the rainwater and also optimizes the weeding, pest and disease control operations. Its use is however, limited by the presence of stumps, stones or slopes steeper than 5 percent.

The cost of an animal-drawn toolbar is approximately US\$ 1 500 and for a trained pair of animals, about US\$ 1 000. The hourly cost to hire a wheeled tractor is between US\$ 12 and 15.

### ***In situ* capture of rainwater: tied ridges**

The system for *in situ* capture of rainwater using tied ridges has been further developed by EMBRAPA-CPATSA. It consists of ploughing and ridging at a 0.75 m row spacing, followed by an operation to tie the ridges with small mounds along each furrow so as to impede the runoff of the rainwater. Tying the ridges is done with an implement designed for use with animal traction (Figures 52 and 53) and should be undertaken before planting on the ridges.

The mounds are at intervals between two and three metres, controlled by the operator of the implement, care being taken to leave them at a height that is less than that of the main ridge to be used for planting (Figure 54). For this system, hoeing or weeding is achieved by using a ridger between the rows and making a second pass with a handhoe between the plants.

The tied-ridger implement may be constructed in small workshops, by local blacksmiths and costs about US\$ 180. It needs little tractive force and can be drawn by small animals such as

FIGURE 51  
Ridging before planting

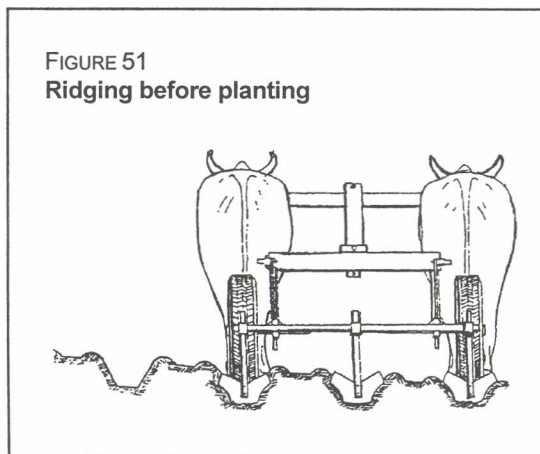

FIGURE 52  
Tied ridges made with an animal drawn toolbar

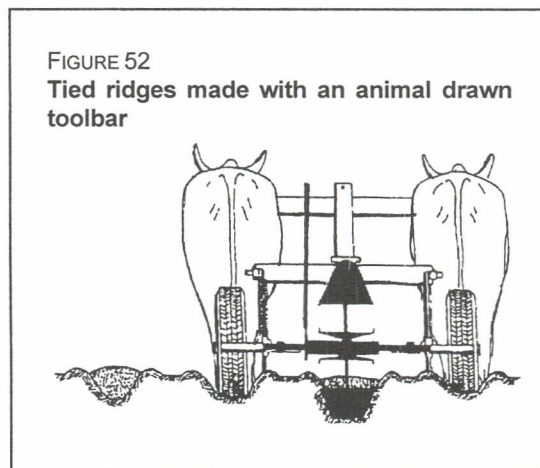
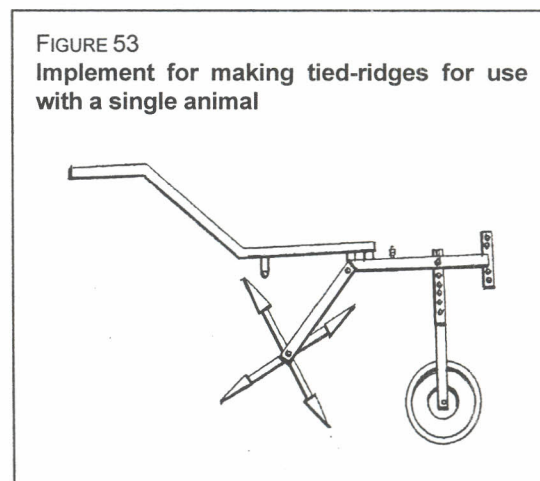

FIGURE 53  
Implement for making tied-ridges for use with a single animal





donkeys, whose average cost is about US\$ 70. Hire cost for the animal powered system are about US\$ 0.90/h.

### ***In situ* capture of rainwater: partial ploughing**

The system for *In situ* capture of rainwater through partial ploughing consists of two successive passes with a reversible animal-drawn plough, leaving a distance of 0.60 m from each second furrows. In this manner, the work time is reduced by half due to the ploughing being accomplished in strips. The unploughed land between the strips is used for harvesting the rainwater, leading it to the seed zone (Figure 55).

Sowing for this system is accomplished with a punch planter into the second furrow left by the plough in each strip, the inter-row spacing being one metre. The system is re-established, thus promoting a gradual rotation of the cropping area. Hoeing or weeding can be done manually with a handhoe when the plants have reached a height of about 0.10 m. A reversible mouldboard plough may be used, ploughing the unploughed strip towards the plants (ridging) and eliminating the weeds at the same time (Figure 56).

Only a low investment cost is involved in this system. The plough costs US\$ 150 and a horse, around US\$ 300. The same plough is used for the soil preparation for planting and for the mechanical weeding operation. Hire costs for the implement are US\$ 0.70/h.

### ***In situ* capture of rainwater: the Guimarães Duque method**

According to Silva *et al.* (1982), the first *in situ* rainwater harvesting technique, adapted to the semi-arid zone of the north-east, was developed by INFAOL (the North-eastern Institute for the Development of Cotton and Oilseed Crops) and was known by the name "the Guimarães Duque Method for Dryland Tillage". The method was adapted by EMBRAPA-CPATSA for growing annual crops, mainly cowpea and maize.

FIGURE 54  
Tied-ridge system

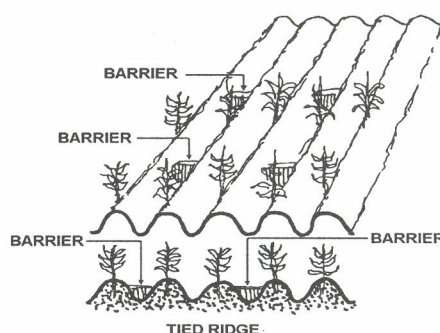

FIGURE 55  
Strip ploughing system

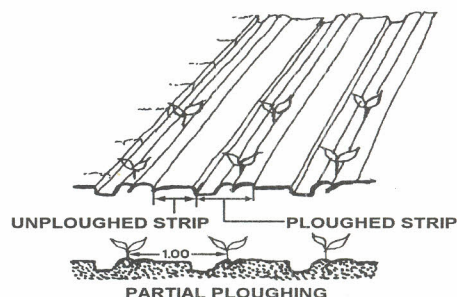
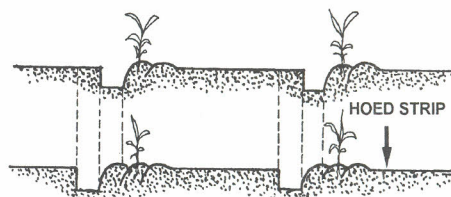
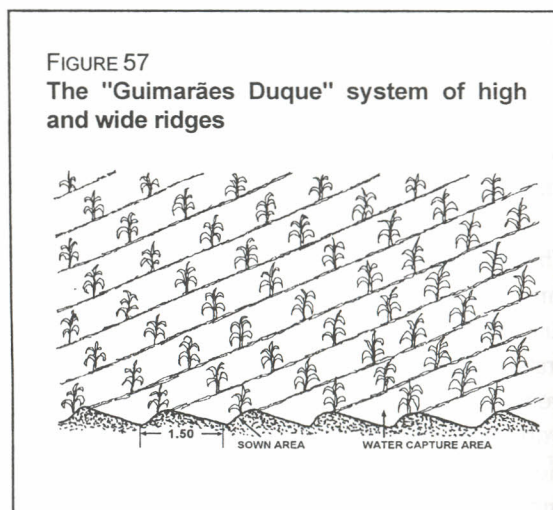

FIGURE 56  
Method for mechanical hoeing or weeding with animal traction



The Guimarães Duque method consists of forming the furrows followed by shaping high and wide ridges or beds, which follow the lines of equal contour. A three-furrow reversible disc plough is used for the operation but it is recommended to remove the front disc, nearest to the tractor tyres, the remaining two discs accomplishing the task. .

The tractor operator should commence the ridge formation by working parallel to a furrow that has already been ploughed along a contour line. After the first furrow, to make the second the tractor should be carefully manoeuvred so that the tyres pass over the land that has not yet been ploughed, bordering the first furrow. Successive passes are made in a similar manner. This procedure allows shaping the capture area between the ridges, which have a spacing of 1.5 m (Figure 57).



This system is semi-permanent as it can last from three to five years. The system can also be adapted to different crops, using an animal drawn mouldboard plough to loosen the soil in the planting zone.

The hire of the tractor costs between US\$ 12 and 15/ha and the ridge formation normally takes 1.6 h/ha.

### ***In situ* capture of rainwater**

The *in situ* capture of the water is a soil tillage technique, related to the storage of rainwater coming from the surface runoff, which has been studied over the last two decades. It is quite probable that work commenced much earlier during colonial times when plantations of sugar cane were established in the semi-arid North east of Brazil using a system of rectangular pits.

The system is still used today as it provides better moisture conservation in the soil. This is because the soil that has been dug from the pits is then spread around the hole, so breaking up the capillarity and restricting the loss of water.

### **Cultivating land as the water recedes (recession agriculture)**

Recession agriculture implies using the soils that have potential for cultivation in dams, along the sides of rivers and lakes, which are inundated water during the rainy season (Duque, 1973 and Guerra, 1975).

Land from which the water has receded is mainly exploited by small farmers using handtools and, to a lesser extent, animal traction. The most commonly grown crops are rice, beans, sweet potato and maize (Carvalho, 1973).



According to Silva and Porto (1982), there are more than 70 000 public and private dams distributed throughout north-eastern Brazil. This allows the survival of some 3 million persons, even during periods of acute drought, exploiting the land as the waters recede (Guerra, 1975).

The most commonly used implement is an 8 inch (0.20 m) animal drawn mouldboard plough. It costs about US\$ 150 and the work animal, some US\$ 300 giving a total investment cost of US\$ 450. The hire cost for the same equipment is some US\$ 0.96 per hour. Hire costs for a tractor are between US\$ 12 and 15 per hour but it is difficult to work in wet soils as the weight of the equipment makes movement of the machinery very difficult.

### **IRRIGATION ASPECTS**

It is interesting to observe that ancient civilizations had their origins in arid regions, where production was only possible through the use of irrigation. The large populations that were established more than 4 000 years ago along the fertile banks of the Huang Ho and Yangtze rivers in China, along the Nile in Egypt, the Tigris and Euphrates in Mesopotamia and the Indus in the present-day Pakistan, were all conserved due to the use of water resources (Daker, 1988).

The main source of water in north-eastern Brazil is rainwater. Another considerable potential source of water for farming are the surface waters of perennial rivers of which the San Francisco river is the most important, together with water stored in dams constructed in rivers of more normal flow rates. An important, but little exploited resource are the underground waters originating from rainwater or river water.

The capture, lifting and distribution of water for irrigated agriculture is carried out by a number of methods. In the perennial rivers, water wheels are used which take advantage of the hydraulic energy. Small pumps powered by wind are also used. Electric motors or internal combustion engines running on petroleum derivatives or biomass extracts (alcohol, biogas and gasified vegetative matter) power other pumps.

An excess of irrigation water has negative aspects. These may be summarized as the leaching out of soluble nutrients, the high costs for raising the water and also the fact that it can give rise to poor drainage and consequent salinity problems.

The irrational use of water in north-eastern Brazil has caused a rise in the water table. This approaches the soil surface in certain places and during certain seasons, causing unfavourable conditions for crop development, limiting crop productivity and affecting its quality.

Water containing more than 3 g/l of soluble salts is considered poorly suited or unsuitable for agricultural use. Another basic parameter for classifying irrigation water is sodium, for which a content above 0.3 g/l of Na is considered harmful (Valdiviezo Salazar and Cordeiro, 1985).

### **Irrigation methods**

Selection of a particular irrigation method depends on the availability of financial resources, water quality, infiltration rates, soil type, land topography, amongst other factors.

**Flood irrigation:** this system is characterized by applying a temporary or continuous layer of water to the soil, so totally covering the surface of the land (Soares, 1988).

**Furrow irrigation:** the irrigation infrastructure is based on engineering works (distribution canals) but it is normally constructed using handtools with soil from the site. The irrigation is not controlled, the water being diverted with earth blockages made with a spade. It would be preferable to use siphons of an appropriate diameter or some other type of flow control system, taking an example from areas being farmed according to adequate planning methods.

**Porous capsules:** these are receptacles with a capacity of between 0.6 and 0.7 litres connected to a hydraulic water supply network which makes up the irrigation system. They are made from non-swelling clay, which is injected in the form of an aqueous paste into a plaster (gypsum) mould. After removal from the mould and trimming off the edges, an opening is made where a plastic tube will be introduced to carry the water supplied through the network. The capsule is dried and baked to 1 20°C to strengthen it and to attain a porosity of about 20 percent (Silva *et al.*, 1981). The porous capsule irrigation method works at low pressure and has a low water consumption of about 5 litres per unit/day.

**Irrigation with earthen pots:** these are receptacles with a capacity of between 10 and 12 litres, which are made from clay, dried and baked to give them strength and porosity. Normally, the pots are interconnected with ½ inch (12.7 mm) diameter plastic piping, receiving the water from the supply source. In this way, the labour requirement to supply individual pots is reduced (Silva *et al.*, 1982).

The operational principle of the capsules and the earthen pots is based on when the plants take up moisture from the soil, they generate a difference of water potential between the soil and the porous unit. This causes the water to flow to the soil and to adequately supply the moisture requirements of the crop.

**Localized irrigation by drippers and micro-sprinklers:** this is characterized by the application of water to the part of the soil that is explored by the plant roots. The application may be periodic or continuous, generally with a pressurized distribution system through small filters and with short irrigation intervals, which maintain ideal moisture levels for the crop (Bernardo, 1982). The operating principles of set localized irrigation systems are illustrated in Figure 58.

**Sprinkler irrigation:** this is one of the most widely used systems in recent times. It is characterized by the uniform water application, the high efficiency of the system, the ease to eliminate erosion risks and the possibility for its use in a wide range of different topographies and soil types.

**Central pivot:** this is a type of sprinkler irrigation system where the unit consists of a lateral line with sprinklers which moves in a circle around a central pivot at a constant and pre-selected

FIGURE 58  
Schematic diagram of the drip irrigation system

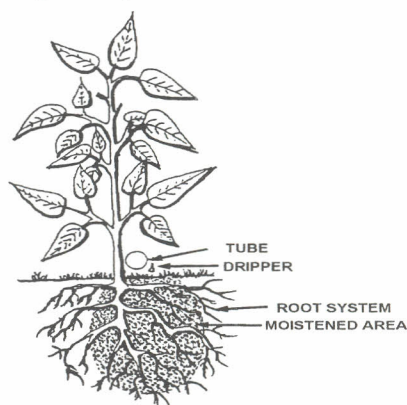



speed. Because the system drives itself around the pivot, operational labour requirements are reduced and the system can also directly apply fertilizers and pesticides via the irrigation water (EMBRAPA, 1988).

### Soil/water/plant management

Management of the soil water is directly related to the crop planted and to the irrigation system adopted.

Precise definition of the details of the management system may be based on a measure of any of the soil-plant-atmosphere components. When a standard Class A evaporation tank is used, the irrigation schedule may be calculated on the basis of the daily evaporation rate according to the following calculations:

- Calculation of the mean daily evaporation ( $E_v$ )

$$E_v = \frac{E_{v1} + E_{v2} + \dots + E_{v7}}{7} \quad (\text{Equation 1})$$

where:

$E_v$  = Mean daily evaporation (mm)

$E_{v1-7}$  = Daily evaporation (mm)

- Calculation of the daily depth of irrigation required ( $L_b$ )

$$L_b = \frac{K_p \times K_c \times E_v}{c_u/100} \quad (\text{Equation 2})$$

where:

$L_b$  = Lamina of irrigation water applied (mm)

$K_p$  = Tank Factor, equal to 0.75

$K_c$  = Crop Coefficient

$c_u$  = Coefficient of uniformity of the irrigation system (%), which must be determined locally.

- For drip irrigation and systems with micro-sprinklers, the volume of water to be applied through each application unit depends on the lamina of irrigation water required and the number of plants for each irrigation sub-unit.

It follows that:

$$V_{ap} = \frac{L_b \times E_p \times E_f}{D} \quad (\text{Equation 3})$$

where:

$V_{ap}$  = Volume of water applied per plant (l/plant/day)

$E_p$  = Inter-plant spacing (m)

$E_f$  = Plant row spacing (m)

D = Number of days interval between irrigation applications

- The time required to apply the irrigation lamina will be:

$$T_j = \frac{V_{ap}}{N \times q_e} \quad (\text{Equation 4})$$

where:

$T_j$  = Irrigation time for each irrigation unit (hours)

N = Number of drippers per plant

$q_e$  = Flow rate of the drippers (t/h) (this parameter should be determined during field tests)

When irrigation times exceed three hours, it is recommended that the application should be divided into two stages so as to avoid excessive water losses due to deep percolation and asphyxiation of the root system.

- In the case of semi-automatic drip and micro-sprinkler systems, the volume of water per unit should be determined.

$$V = 10 \times L_b \times A \quad (\text{Equation 5})$$

where:

V = Volume of water per irrigation unit ( $m^3$ )

A = Application area of the irrigation unit (ha)

- For sprinkler irrigation systems, the amount of irrigation water required during the period of greatest development for crops such as tomato, onion, melon and watermelon, may be calculated on the basis of the evaporation accumulated over weekly periods in a Class A tank (Azevedo *et al.* 1986). The calculation uses Equation 6 below:

The amount of irrigation water required is:

$$L_b = \frac{K_p \times K_c \times E_v}{E_i} \quad (\text{Equation 6})$$

where:

$L_b$  = Lamina of irrigation water applied (mm)

$K_p$  = Tank Coefficient for a Class A tank (taken as 0.75 or a table established for the particular area should be used)

$K_c$  = Crop Coefficient

$E_v$  = Mean daily evaporation from the tank (mm)

$E_i$  = Efficiency of the irrigation system, determined during field trials

When the soil moisture content is not measured, the soil water availability should be estimated on the basis of tables developed and adapted to the particular locality, so as to determine the time required for the next irrigation operation (Table 37).



TABLE 37

Values of the Tank Coefficient for a Class A tank ( $K_p$ ) for estimated values of the reference rate of evapotranspiration ( $E_0$ )

UR % (mean)	Exposure A Tank surrounded by grass			Exposure B Tank surrounded by bare soil				
	Low <40%	Medium 40-70%	High >70%	Low <40%	Medium 40-70%	High >70%		
Wind (km/day)	Tank position R(m)*			Tank position R(m)*				
Slight <175	0	0.55	0.65	0.75	0	0.70	0.80	0.85
	10	0.65	0.75	0.85	10	0.60	0.70	0.80
	100	0.70	0.80	0.85	100	0.55	0.65	0.75
	1 000	0.75	0.85	0.85	1 000	0.50	0.60	0.70
Moderate 175 – 425	0	0.50	0.60	0.65	0	0.65	0.75	0.80
	10	0.60	0.70	0.75	10	0.55	0.65	0.70
	100	0.65	0.75	0.80	100	0.50	0.60	0.65
	1 000	0.70	0.80	0.80	1 000	0.45	0.55	0.60
Strong 425 – 700	0	0.45	0.50	0.60	0	0.60	0.65	0.70
	10	0.55	0.60	0.65	10	0.50	0.55	0.75
	100	0.60	0.65	0.75	100	0.45	0.50	0.60
	1 000	0.65	0.70	0.75	1 000	0.40	0.45	0.55
Very strong >700	0	0.40	0.45	0.50	0	0.50	0.60	0.65
	10	0.45	0.55	0.60	10	0.45	0.50	0.55
	100	0.50	0.60	0.65	100	0.40	0.45	0.50
	1 000	0.55	0.60	0.65	1 000	0.35	0.40	0.45

Observations:

For extensive areas of bare soil and in conditions of high temperature and strong wind, reduce the value of  $K_p$  by 20%. In moderate conditions of temperature, wind and humidity, reduce the value of  $K_p$  by between 5 and 10%.

\* R(m) is the least distance (expressed in metres) from the centre of the tank to the limit of the border (of grass or bare soil).

Source: Tuler *et al.* (1983)

- The irrigation time is calculated as:

$$T_i = \frac{L_b}{I_a} \quad (\text{Equation 7})$$

where:

$T_i$  = Irrigation time (hours)

$I_a$  = Application rate of the sprinkler, measured in the field (mm/h)

Equation (6) may also be used for furrow irrigation to calculate the amount of irrigation water required ( $L_b$ ). The irrigation time ( $T_i$ ) is a function of this amount and of the time for the water to advance along the furrow ( $T_a$ ), related to the time of opportunity for irrigation ( $T_0$ ). The times ( $T_a$ ) and ( $T_0$ ) are determined directly by field tests.

The use of tensiometers can assist in controlling irrigation, particularly for areas under drip or micro-sprinkler irrigation. They are well adapted for soils where most of the available water is retained at tensions less than 0.80 bar (Faria and Costa, 1987).