

# Test loop for inter-connections of parabolic trough collectors

Cite as: AIP Conference Proceedings **2033**, 030008 (2018); <https://doi.org/10.1063/1.5067024>  
Published Online: 08 November 2018

Javier León, Javier Clavero, Loreto Valenzuela, Eduardo Zarza, Christoph Hilgert, Wolfgang Reinalter, and Andreas Plumpe



View Online



Export Citation

## ARTICLES YOU MAY BE INTERESTED IN

[MicroSol-R: Versatile solar facility for research and industry](#)

AIP Conference Proceedings **2033**, 030003 (2018); <https://doi.org/10.1063/1.5067019>

[Retrofitting of existing parabolic trough collector power plants with molten salt tower systems](#)

AIP Conference Proceedings **2033**, 030014 (2018); <https://doi.org/10.1063/1.5067030>

[Heat losses model for standardized testing of receiver tubes for parabolic-troughs](#)

AIP Conference Proceedings **2033**, 030016 (2018); <https://doi.org/10.1063/1.5067032>

**AIP** | Conference Proceedings

Get **30% off** all  
print proceedings!

Enter Promotion Code **PDF30** at checkout



# Test Loop for Inter-Connections of Parabolic Trough Collectors

Javier León<sup>1, a)</sup>, Javier Clavero<sup>1, b)</sup>, Loreto Valenzuela<sup>1, c)</sup>, Eduardo Zarza<sup>1, d)</sup>,  
Christoph Hilgert<sup>2, e)</sup>, Wolfgang Reinalter<sup>2, f)</sup> and Andreas Plumpe<sup>2</sup>

<sup>1</sup> CIEMAT - Plataforma Solar de Almería, Solar Concentrating Systems Unit, Ctra. Senés, km 4.5, E04200  
Tabernas, Spain,

<sup>2</sup> German Aerospace Center (DLR), Institute of Solar Research, Plataforma Solar de Almería, Ctra. Senés, km 4.5,  
E04200 Tabernas, Spain

<sup>a)</sup>javier.leon@psa.es

<sup>b)</sup>franciscojavier.clavero@psa.es

<sup>c)</sup>loreto.valenzuela@psa.es

<sup>d)</sup>eduardo.zarza@psa.es

<sup>e)</sup>christoph.hilgert@dlr.de

<sup>f)</sup>wolfgang.reinalter@dlr.de

**Abstract.** The Spanish Centro de Investigaciones Energéticas Medioambientales y Tecnológicas (CIEMAT) through its Plataforma Solar de Almería (PSA), started a program for testing outdoor every individual component of parabolic trough collectors (PTC), i.e. structure, mirrors, absorber tubes, etc., reproducing real solar conditions as well as in laboratories using accelerated aging chambers or appropriate test loops. A very important part pending of testing in an ad-hoc facility were the collectors' inter-connections (ball joints, flexible hoses and hybrid interconnections). In that sense, CIEMAT-PSA and the German Deutsches Zentrum für Luft- und Raumfahrt e.V. (DLR) agreed to erect a common test bench at PSA. The so called Rotation and Expansion Performing Assembly (REPA) enables specific test as well as accelerated full lifecycle tests under realistic conditions, using silicone or mineral oil based HTFs at temperatures up to 450°C. It was erected and commissioned at PSA and it will start its operation late 2017.

The REPA test facility is the result of merging CIEMAT activities in task 14.4 of the European project SFERA-II and DLR activities within the work package 6 of the national German project StaMeP.

In a solar power plant with parabolic trough collector (PTC), one of the main technical constraints in the solar field is dealing with the absorber tubes thermal expansion and collectors rotation motion. The non alignment between the collector focal line and the rotation axis is a key point in the construction of this type of solar field. As consequence, the connection interface between the receiver tubes of adjacent PTC in one side and between headers and both loop ends in the other, must be accomplished using elements tested in real conditions able of absorbing that stress.

“Keywords: Rotation and expansion performing assemblies, parabolic trough collector; component qualification”

## INTRODUCTION

In solar thermal electric plants using parabolic trough collectors (PTC) for collecting the solar energy, the piping for distributing the heat transfer fluid across the solar field is fixed, allowing only the thermal expansion while PTC are rotating elements holding in their linear focus a heat collecting element (HCE), i.e., an absorber tube. Since the PTC are moving all along the day tracking the Sun and the axis of rotation of a PTC is commonly not aligned with its focal line, an interface between the moving HCE and the fixed piping is crucial. In addition, temperature cycles of up to 400°C or more, require a linear compensation of the HCE's thermal expansion and contraction. Using flexible pipe interconnections, the accommodation of thermal expansion as well as of the SCA's rotary movement is

ensured. These flexible interfaces are collectively named with the term Rotation and Expansion Performing Assembly (REPA). The goal of the present document is to describe the design, assembly and functionality of a new facility for the evaluation and testing of the different REPAs. This comprises the examination of existing products in the market as well as the investigation of new future concepts simulating similar conditions to those existing in a commercial plant.

For testing, two identically orientated flexible connections REPA are connected to a relatively small thermal oil circuit that circulates heated HTF at any desired temperature and pressure up to 450 °C and 40 bars through them. Meanwhile the REPAs under investigation can be moved, rotated and expanded, just the way they are moving in real application. Such motions sequences and test procedures are subject to current investigations. This whole process is monitored by a variety of sensors including torque and force sensors that track the mechanical loads of the tested REPA and allow the anticipation of failures before any major leakage could happen.

Due to the characteristics of this test facility loop and considering the increasing demand, it can also be devoted to test new thermal fluids because the circuit of this test facility is able to withstand temperatures and operation pressures as above mentioned and a flowrates of up to 17 liters per second.

## FACILITY DESCRIPTION

The facility is an independent test loop holding all necessary elements to assess the behavior of moving interfaces in a PTC solar field as well as well as to test different heat transfer fluids as thermal oil or silicone based oils.

The test bench is divided into two functional sections, the so called kinematics unit, to hold and move the pieces REPAs to be tested and the balance of plant unit for supplying the conditioned HTF forming altogether a closed loop. It is foreseen to circulate different types of fluids or HTFs, as mentioned before, with similar characteristics; therefore the components are prepared for withstanding operating conditions somewhat higher than those in commercial plants using PTC.

The balance of plant unit is composed of a variable speed HTF pump which circulates the HTF through a pipe with an adapted electrical heater collar type before passing through REPA to be tested, placed in the kinematics unit. The return line runs directly to the suction side of the pump closing the circuit. The system is connected to an expansion vessel able to compensate the volume difference caused by the density variation of the working fluid when its temperature changes. In figure 1 it is depicted the loop scheme considering some potential improvements as automatic valves and a cooler.

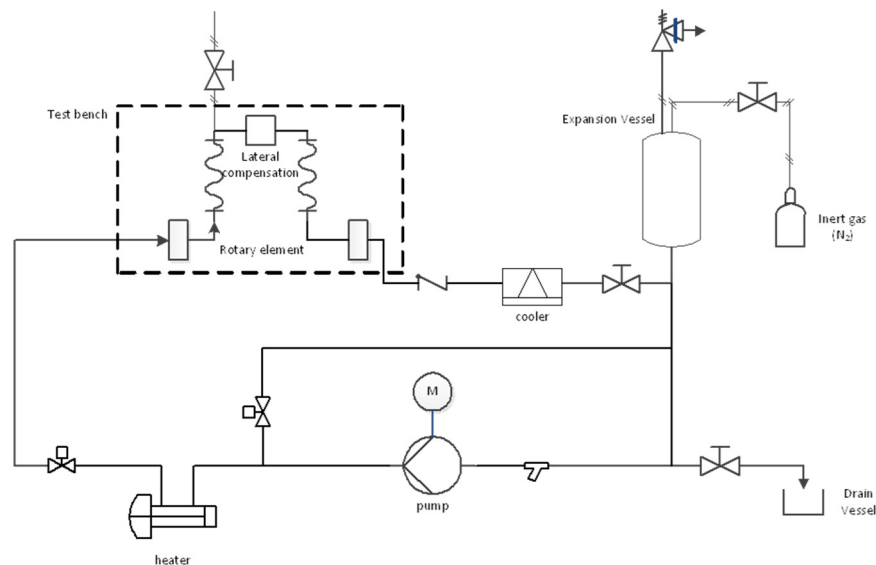

FIGURE 1. Schematic diagram of the REPA test loop at PSA

## DESIGN AND CONSTRUCTION OF THE FACILITY

The objective of the project is to simulate in the new facility the behavior of different REPA types along the expected lifetime, depending on the number of cycles it will normally correspond from 20 to 25 years. It is also foreseen to investigate the influence of the interactions with connecting pipes. Since the operation will be performed in accelerated conditions, the rest of components will also suffer from a faster ageing.

The complete test loop is placed on a concrete platform surrounded by 10cm curb prevents leakages to the environment in case of spill. The entire facility is located inside a metallic shed where a security wall has been erected for separating the kinematics unit from the balance of plant unit. The three outer walls are open 60cm from the ground for allowing sufficient ventilation and thus avoiding potential HTF smoke accumulation in case of leaks.

The test bench holding the REPA to be tested is part of a HTF circuit forming altogether a closed hydraulic loop. It is enabled to circulate different types of fluids like thermal oil, silicones based HTF or similar fluids. The components are prepared for withstanding operating conditions similar in temperature, pressure and thermal expansion to those in commercial plants using PTC.

Inter-connections designed for solar fields must withstand the rotation of the PTC as well as for absorbing the thermal expansion and contraction that originate in the absorber tubes when they are heated from ambient to operating temperature, around 400°C, and the reverse process of cooling down.

In general, there are two commercially successful concepts for REPA, Ball Joint Assemblies (BJA) and Rotary Flex Hose Assemblies (RFHA).

The new REPA test stand is suitable to carry out accelerated life-cycle tests with both types of REPA existing in the market for a solar field. It is also prepared for simulating connections of different PTC with adjustable focal length mechanism. The facility operates at up to 450°C and 45 bar, foreseeing the availability of new HTF and materials in the future.

With those premises, the design of the test loop installation was divided in two sub-units:

- The so-called “kinematics unit” accommodates the test objects complying with varying and therefore adjustable geometries, e.g. focal lengths. It must accomplish both rotational and translational movements. These movements are speeded up distinctly for the purpose of simulating accelerated life cycles of REPA. The rotation movement also simulates a step by step collector tracking.
- The “Balance Of Plant (BOP) unit” is connected to the above mentioned kinematic unit. The HTF circuit serves to carry the fluid through the test objects. In doing so, the fluid’s properties can be adjusted in terms of mass flow, temperature, and pressure while being able to immediately disconnect the REPAs under testing from the HTF cycle in case of failure or leakage.

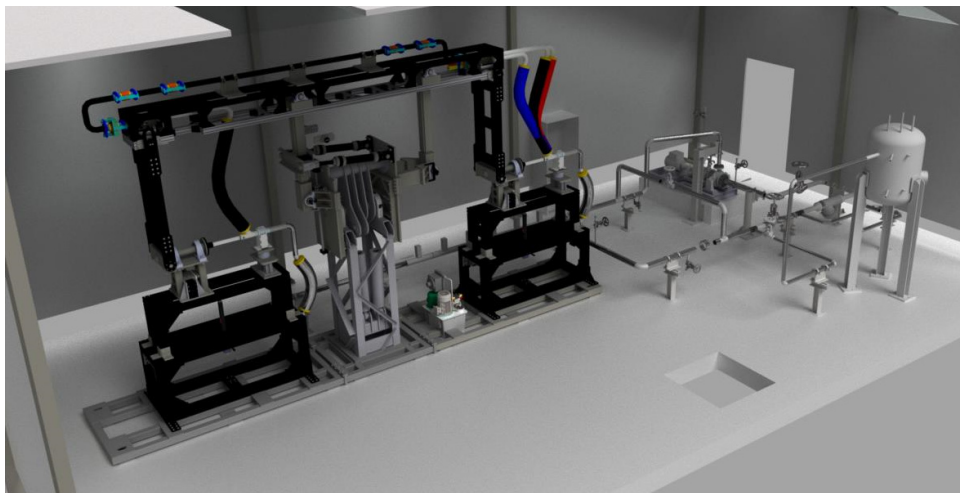

**FIGURE 2.** Scheme showing the complete test loop, REPA kinematic unit and BOP

After finishing the detailed design, see figure 2, the test bench was manufactured and connected to a small (BOP) where an expansion vessel, a pumping system and piping-heating elements are installed. The test loop is fully automatized by means of a SCADA system that is responsible of controlling every mobile part of the system as well

as to supervise the safety conditions and performing the data acquisition allowing continuous operation along several days during 24 hours a day.

## MAIN CHARACTERISTICS

The test loop components were designed for withstanding a similar operation to those in a commercial plant solar field but with some modifications that allow performing a faster operation of the system, mainly in the rotating cycles execution. The main characteristics of the test facility are:

- Kinematic unit:
  - Drive pylon: The structure corresponds to that of a modified EuroTrough drive pylon structure for allowing the simultaneous installation of two sets of the rotating devices to be tested. It has the possibility of continuous and discontinuous radial motion. The rotating angle is  $205^\circ$ , with the stow position in  $25^\circ$  facing down.
  - Up to  $45^\circ$  of lateral motion, representing absorber tube thermal expansion.
  - The devices can be of different sizes contemplating the increasing dimensions of the new PTC designs. The radius can be in the range of focal length from 1m to 2.3m
  - It is suitable for flexible hoses and ball joint assemblies.
  - Precisely measuring the reaction forces and torques of the assemblies under testing (prediction failure before it actually takes place as part of the safety concept).



**FIGURE 3.** BOP and nitrogen stand of the REPA test loop at PSA.

The BOP is composed of a variable speed HTF pump which circulates the thermal oil through an electrical heating system before passing through the elements to be tested, placed in the test bench. The system is connected to an expansion vessel able to compensate the HTF volume difference caused by its big density variation with thermal changes, figure 3. It is foreseen in a following phase to add an oil cooler to the suction of the pump and increase the heating power. The elements forming part of the BOP are:

- HTF Pump: The design is compatible with both thermal oil and silicone oil. The pump has been chosen according to this requirement. It is centrifugal type prepared for operating at  $450^\circ\text{C}$  with a maximum flow of  $60\text{ m}^3/\text{h}$ . The flow is controlled by modifying the pump speed with a speed variator (variable frequency drive). For avoiding malfunctioning of the pump, a recirculation line at the pump discharge is installed which it is now manually operated and in the future it will be controlled by automatic valves.
- Electrical heaters: The heating elements increase the temperature to the desired test value. It is formed by six individual collars mounted all around the pipe. Each element is operated individually in such a way that the heating process as well as the temperature set point can be controlled at all times.
- HTF Expansion vessel: Due to the high change in volume caused by temperature variations, it is necessary to use a vessel for compensating those changes

- Inertization system: Due to the HTF characteristics it is necessary to have a pressurized blanketing system to avoid fluid vaporization as well as keeping an atmosphere free of oxygen in the expansion vessel, thus eliminating a fire risk. The gas used is nitrogen and there is a control station for maintaining a security pressure, providing more gas or removing it from the tank through controlled automatic valves.
- Supervisory Control And Data Acquisition (SCADA) system: All data will be gathered on-line using a data acquisition system in order to process the sensors readings and analyze the results after measurement campaigns. Such data bases include HTF flow, temperatures and pressures in different point of the circuit, and forces and torques of the mechanism where the elements under testing are installed. It also includes safety relevant parameters like leakage and smoke detectors enable a detailed understanding of possible malfunctions as well as the documentation of the wear of individual components over time. Data acquisition and main control are executed in a PLC, while the secondary control, monitoring, operator interface and data management are performed in a SCADA programmed in Labview which runs in a computer.
- Safety system: It is composed by several elements
  - Smoke detectors
  - Pressure loss detection
  - Leakage detection
  - Reaction force/torque monitoring

## TEST PROCEDURE

The present facility it is foreseen for giving a service to the industry simulating operation conditions similar to those existing in commercial solar power plants. The fact of been “indoor” instead of using a real solar field is due to the necessity of performing the amount of cycles corresponding to the real life of a REPA in shortest period of time.

The initial preoperational tests started making the necessary fittings in the rotation and translation elements to assure a representative kinematics unit behavior, exactly alike the PTC rotation and absorber tube expansion where it is meant to function. Figures 4 and 5 depict the kinematic unit in several positions.



**FIGURE 4.** Kinematic unit rotation test into stow position (a) and at 45° position (b)

The exact test procedure will depend on the requirements of the manufacturers and application requirements. This includes the definition of the following parameters: maximum and minimum temperature, number of temperature cycles, mechanical boundaries as rotation angle or lateral displacement, number of mechanical cycles, speed and number of steps of rotation, pressure level, HTF type, and volume flow. It will also include trip criteria for finishing the operation.



**FIGURE 5.** Kinematic unit rotation test in vertical position and translation pistons contracted

Test should be performed at different temperature levels, from ambient to the maximum allowed temperature by both, HTF and component to be tested.

Keeping constant fluid conditions, i.e. temperature, pressure and flow, the system will be rotating faster than a PTC drive unit usually does, thus simulating long periods of activity.

All variables will be measured, including a cycle counter, and recorded using the corresponding transmitters and acquisition cards connected to a computer

## **CONCLUSIONS**

The existing test facility already passed all preoperational tests consisting in materials and mounting procedure qualification and pressure test revised by a notified body (Nobo). The filling procedure with HTF was performed, pumping, and heating the fluid for several hours over water evaporation temperature eliminating the water content. Every signal was checked and speed variators configured as well as checking of rotating and translation hydraulic system. The unit motion was also checked from a screen panel existing on site.

Up to date, the facility is operated manually and it is expected to have it fully automatized before November 2017 after finishing the SCADA programming at the remote PC.

In a second phase an improvement of the system is considered. It will consist in increasing the heating power for shortening the heating periods and introducing a cooling system for simulating thermal cycles similar to those existing in commercial solar fields.

## **ACKNOWLEDGMENTS**

Financial support by the SFERA-II project (Grant Agreement no. 312643) in the 7th Framework Programme of the EU and the StaMeP project financed by the German government are gratefully acknowledged.