

Accepted Manuscript



Gift Giving at Israeli Weddings as a Function of Genetic Relatedness and Kinship Certainty

Sigal Tifferet, Gad Saad, Mali Meiri, Nir Ido

PII: S1057-7408(17)30045-1
DOI: doi:[10.1016/j.jcps.2017.06.003](https://doi.org/10.1016/j.jcps.2017.06.003)
Reference: JCPS 585



To appear in: *Journal of Consumer Psychology*

Received date: 11 April 2016
Revised date: 23 June 2017
Accepted date: 25 June 2017

Please cite this article as: Tifferet, S., Saad, G., Meiri, M. & Ido, N., Gift Giving at Israeli Weddings as a Function of Genetic Relatedness and Kinship Certainty, *Journal of Consumer Psychology* (2017), doi:[10.1016/j.jcps.2017.06.003](https://doi.org/10.1016/j.jcps.2017.06.003)

This is a PDF file of an unedited manuscript that has been accepted for publication. As a service to our customers we are providing this early version of the manuscript. The manuscript will undergo copyediting, typesetting, and review of the resulting proof before it is published in its final form. Please note that during the production process errors may be discovered which could affect the content, and all legal disclaimers that apply to the journal pertain.

Gift Giving at Israeli Weddings as a Function of Genetic Relatedness and Kinship Certainty

Sigal Tifferet^a^aDepartment of Business Administration

School of Economics and Business Administration

Ruppin Academic Center

Emek Hefer 40250

Israel

tifferet@ruppin.ac.il

Gad Saad^b^bJohn Molson School of Business

Concordia University

1455 de Maisonneuve Blvd. West

Montreal, Quebec, Canada

H3G 1M8

gad.saad@concordia.ca

Mali Meiri^a^aDepartment of Business Administration

School of Economics and Business Administration

Ruppin Academic Center

Emek Hefer 40250

Israel

malicohen123@gmail.com

Nir Ido^a

^aDepartment of Business Administration

School of Economics and Business Administration

Ruppin Academic Center

Emek Hefer 40250

Israel

nir.ido1@gmail.com

Corresponding Author: Sigal Tifferet, Department of Business Management, Ruppin Academic Center, Emek Hefer 40250, Israel. tifferet@ruppin.ac.il. Phone: +972-9-8983035, Fax: +972-9-8987604

Gift Giving at Israeli Weddings as a Function of Genetic Relatedness and Kinship Certainty

ACCEPTED MANUSCRIPT

This study examines gift giving at Israeli weddings. In accordance with kin selection theory, we hypothesized that wedding guests possessing greater genetic relatedness to the newlyweds would offer greater sums of money as wedding gifts. We also hypothesized that family members stemming from the maternal side (where the genetic lineage has higher kinship certainty), would offer the newlyweds more money than those stemming from the paternal side. Data on the monetary gift sums of the wedding guests from 30 weddings were collapsed according to two criteria: (1) genetic relatedness (0%, 6.25%, 12.5%, 25%, and 50%) and (2) kinship certainty (maternal or paternal lineage). Both hypotheses were supported. We discuss the implications of these data in understanding family dynamics, as well as practical applications associated with the marketing of gifts.

Keywords: evolutionary psychology, gift giving, wedding, kin selection, paternity uncertainty

Gift Giving at Israeli Weddings as a Function of Genetic Relatedness and Kinship Certainty

A wedding constitutes a key rite of passage with substantial economic, social, and anthropological importance. In the United States alone, weddings are a 160-billion-dollar industry (Mead, 2008), with an average cost of \$32,641 (“The Knot real weddings survey,” 2015). Many elements of the wedding ritual are culture-specific, perhaps none as conspicuous as the color of the bride’s dress (e.g., white in the West and red in China). Notwithstanding the importance of cultural traditions, numerous aspects of the wedding ritual speak to a shared and universal human nature. For instance, in most cultures, marriage is an economic transaction that is celebrated by music, dance, food and drink (Terian, 2004). In the current paper, we focus on one universal, namely the ubiquitous gift giving ritual, in the context of Israeli weddings. In contemporary Israeli weddings, it is customary to give money as a gift and to prepare detailed lists of the sums received from every guest (Abuhav, 1998; Triger, 2011). This custom is similar to that of Koreans (Park, 1997) or the Japanese (Brumann, 2000). Guests of Israeli weddings give approximately \$300 for a close relative’s wedding gift and \$100 for acquaintances (Orly, 2013). In addition to genetic closeness, the sum of the wedding gift is dependent on the cost of the wedding (Orly, 2013; Triger, 2011) and the gift sums that were previously given by the newlyweds or their parents (Orly, 2013). In the past, both dowry (*Nedunia*) and brideprice (*Mohar*) were practiced in Judaism (Adar-Bunis, 2007). These customs, however, are no longer practiced in Israel (WomanStats, 2016). In the current paper, we use evolutionary theory as the explanatory framework to propose that the genetic relatedness between wedding guests and newlyweds, as well as the kinship certainty of these relationships, will affect the size of the monetary gift.

Evolutionary Psychology

Evolutionary psychology posits that the same evolutionary forces that have molded our morphological features are responsible for designing the organ that defines our personhood—our brain. Traits that were adaptive in our prehistoric past were selected for, and their frequency within the population increased; traits that were detrimental to our survival or inclusive fitness (propagating one's genes via kin) were selected against, and their frequency decreased. Helping out kin, for instance, would have increased the kin's chances of survival. When they reproduced, they would have passed on some of the family genes, including the genes that increase kin altruism. This process continued over generations until, eventually, kin altruism spread across the population.

Why do we help our kin? Evolutionary theory distinguishes between proximate and ultimate causes in addressing such questions (Alessi, 1992; Saad, in press). Proximate explanations focus on the mechanistic processes linked to a phenomenon. For instance, we help kin, since they are emotionally close to us (Korchmaros & Kenny, 2006). Ultimate explanations, on the other hand, seek to elucidate the evolutionary function of the phenomenon. Natural selection has favored genes that make us feel emotionally close to our kin since these genes increase the chances of our kin survival and reproductive prospects and with it the reproduction of the genetic inclination for kin altruism.

Evolutionary Consumption

The great majority of research within marketing and consumer behavior has operated at the proximate realm (Saad, 2007). In recent years, however, evolutionary psychology has emerged as a valuable theoretical framework for the study of consumer behavior (Durante, Griskevicius, Hill, Perilloux, & Li, 2011; Griskevicius et al., 2009; Miller, 2009; Saad & Gill,

2000; Saad & Stenstrom, 2012; Saad, 2007, 2011, 2013). Most explanatory theories regarding gift giving are proximate in nature (e.g., we offer gifts to those who are emotionally close to us); in this study, we offer an ultimate explanation (kin selection predisposes us to offer larger gifts to those who are genetically closer to us). These two explanatory levels are complementary and can be seen as two stages in a process. As such they offer a mutually exhaustive account of a given phenomenon.

Kin Selection

Hamilton (1964a) proposed that the investment in kin is a function of genetic relatedness. According to Hamilton (1964b), altruistic acts can be selected for when $b*r > c$, where b is the benefit to the recipient, r is the level of genetic relatedness between the altruist and the recipient, and c is the cost to the altruist. A consequence of Hamilton's rule is that in some species individuals may display greater altruism toward kin versus non-kin, and toward close versus distant kin. These patterns have been documented across numerous animal taxa (Griffin & West, 2003; Hauber & Sherman, 2001). Studies on humans also show that people invest more in their kin. For instance, parental investment is higher in biological children than in stepchildren (Daly & Wilson, 1980; Tifferet, Jorev, & Nasanovitz, 2010), and people are more inclined to help close rather than distant kin (Burnstein, Crandall, & Kitayama, 1994; Korchmaros & Kenny, 2001; Webster, Bryan, Crawford, McCarthy, & Cohen, 2008).

Kinship Certainty

Genetic relatedness is central in explaining differential kin solicitude, but it is only part of the story. Kinship certainty may also play a role. In our evolutionary history, fathers could never be certain that a child was theirs whereas mothers did not face this threat. Indeed, in an analysis of cross-cultural studies Voracek, Haubner, and Fisher (2008) calculated a mean nonpaternity

rate of 3.1%. The sex difference in parental certainty may have consequences across numerous family relationships. For example, among grandparents, a maternal grandmother has the highest kinship certainty, since only she can be assured that her daughter is indeed her own and that her grandchild is indeed her daughter's offspring. On the other hand, a paternal grandfather has the lowest kin certainty, since he has two generations of paternal uncertainty (Euler & Weitzel, 1996). Similarly, maternal aunts, uncles, and cousins have higher levels of kinship certainty than do paternal ones, since they are related to the parent with the higher parental confidence (i.e., the mother). Although there is some cultural variability (e.g., Pashos, 2000), many studies have shown that investments in one's kin display a matrilineal bias that may result from kinship certainty (see review in Euler, 2011). Some suggest that the matrilineal bias in itself is an indication of a high non-paternity rate in ancestral times (e.g., Gaulin, McBurney, & Brakeman-Wartell, 1997; Hoier, Euler, & Hänze, 2001).

This matrilineal investment bias is not solely driven by kinship certainty. It is also based on the principle that across sexually reproducing species, the sex that bears the greater minimal obligatory parental investment will exhibit a stronger bond to its offspring (Trivers, 1972). There are also social explanations for the matrilineal investment bias. Matrilineal relatives may invest more than patrilineal ones since on occasion they might live in closer proximity thus resulting in greater familiarity and stronger emotional closeness. Furthermore, cultural norms might dictate that matrilineal relatives invest more than patrilineal relatives. However, these factors do not necessarily compete with or refute the evolutionary explanations. Proximity, familiarity, and emotional closeness can be construed as proximate mechanisms that instantiate the ultimate explanation. Familiarity and proximity, for instance, may serve as a cue for kin recognition, as suggested in primate studies (Widdig, 2007). All told, affiliative bonds are not solely driven by

genetic considerations, as ecological (cultural) circumstances can modify genetic expressions, creating a broad range of diverse behaviors.

Gift-giving

The gift giving ritual is a universal human activity (Sherry, 1983). As such, we propose that natural selection has played a part in shaping the social behaviors that regulate this custom, and predict that both kin selection and kinship certainty will be at play. Although many business scholars have studied gift giving (e.g., Flynn & Adams, 2009; Giesler, 2006; Laroche, Saad, Cleveland, & Browne, 2000; Marcoux, 2009), only Saad and Gill (2003) have done so using an evolutionary perspective within the marketing literature. They found that students estimated spending more money on gifts to close kin with 50% genetic relatedness, in comparison to distant kin, with 25% or 12.5% genetic relatedness. Their study, however, was based on hypothetical budget allocations, and as such did not measure actual gift-giving records. Furthermore, it did not explore the effects of kinship certainty. Previous studies that have assessed kinship certainty did not do so in the context of gift-giving and were mostly limited to grandparents. The current work adds to this growing literature by testing two general hypotheses rooted within kin selection and kinship certainty in the context of Israeli weddings:

H1: Wedding guests with higher genetic relatedness to the newlyweds will offer larger sums of money.

H2: Matrilateral family members (relatives of the mothers of the bride and the groom, for example, maternal grandparents) will offer the newlyweds larger sums of money than patrilateral family members (relatives of the fathers of the bride and the groom, for example, paternal grandparents).

Method

Participants and Procedure

Most studies on kin investment have relied on student self-reports (Euler, 2011). The present study analyzes actual monetary gifts offered by wedding guests. This method decreases potential bias, such as social desirability, selective memory, and the unreliability of responses to hypothetical scenarios. Home interviews were conducted with 30 young couples who were married within the past five years and who possessed a full record of the monetary gifts they had received for their wedding. All couples were secular Jews who lived in cities in central Israel. There were 411 guests on average at a wedding ($SD = 120$), with an average cost of \$32,500 per wedding ($SD = \$5,260$).

Measures

Demographic details of the bride and groom included age, place of residence, family income, and parental ethnicity. Data on the monetary gift sums of the wedding guests were classified into *relationship categories* (e.g., siblings of the bride, maternal cousins of the groom, uncles and aunts of the mother of the bride). For each wedding, categories may have included a single case (e.g., the parents of the mother of the bride) to 10 cases (e.g., the bride's friends) with most categories including four cases each (see Appendix for a detailed description). In total, we analyzed data for 1,789 gifts from kin and close friends (note that most of the wedding guests were acquaintances whose gifts were not analyzed). In all 30 weddings, there was only one case where a guest brought a non-monetary gift. This case was not included in the analysis.

Data analysis

In order to test the two posited hypotheses, the gifts within relationship categories were averaged in two separate ways (see Appendix). First, five *genetic relatedness groups* were created (as in Webster et al., 2008):

0% genetic relatedness (friends of the newlyweds; friends of the parents)

6.25% genetic relatedness (cousins of the newlyweds' parents)

12.5% genetic relatedness (cousins of the newlyweds; uncles and aunts of the newlyweds' parents)

25% genetic relatedness (uncles and aunts of the newlyweds; grandparents of the newlyweds)

50% genetic relatedness (siblings of the newlyweds).

Next, *matrilateral* and *patrilateral* groups were created (as in Jeon and Buss, 2007). The matrilateral group included all kin relationships of the mothers of the bride and the groom; the patrilateral group included all kin relationships of the fathers of the bride and the groom (see Figure and Appendix).

INSERT FIGURE HERE

Results

Genetic Relatedness

In line with kin selection theory, the first hypothesis posits that guests with greater genetic relatedness to the bride and groom would offer larger sums of money as wedding gifts. We therefore tested the difference in the money sums gifted by the 0%, 6.25%, 12.5%, 25%, and 50% groups. Mauchly's test indicated that the assumption of sphericity had been violated, $\chi^2(9) = 86.74, p < .001$; therefore, degrees of freedom in the ANOVA and contrasts were corrected using Greenhouse-Geisser estimates of sphericity ($\epsilon = .52$). The results of a within-subjects ANOVA yielded that the mean money sum was associated with the level of genetic relatedness, $F(2, 52, n = 26) = 93.38, p < .001$, Partial $\eta^2 = .79$. More specifically, a planned linear polynomial contrast revealed a positive linear association between the mean gift sum and the level of genetic

relatedness, $F(0.5, 13) = 147.06, p < .001$, Partial $\eta^2 = .86$ (see Table 1; although the trend does not apply across every pairwise comparison of categories, it is statistically significant as a whole).

Four planned orthogonal contrasts for repeated measures (Field, 2009) were conducted. As hypothesized (H1), kin ($M = 253, SD = 54$) gave larger sums of money (in USD) than non-kin ($M = 162, SD = 45$) $F(0.5, 13) = 69.22, p < .001, \eta^2 = .41$, and highly related kin (50% and 25%; $M = 428, SD = 90$) gave larger sums than more distant kin (12.5% and 6.25%; $M = 122, SD = 29$) $F(0.5, 13) = 268.74, p < .001, \eta^2 = .73$. No significant differences were found between the 50% ($M = 393, SD = 133$) and 25% ($M = 424, SD = 123$) groups, $F(0.5, 13) = 0.94, p = .28, \eta^2 < .01$, nor between the 6.25% ($M = 122, SD = 35$) and 12.5% ($M = 123, SD = 31$) groups, $F(0.5, 13) = 0.07, p = .61, \eta^2 < .01$. Hence, while H1 is largely supported, the genetic relatedness effect does not manifest itself when comparing adjacent kin categories (i.e., the effect is not operative at such a granular level).

INSERT TABLE 1 HERE

Matrilateral Investment

As hypothesized in H2, the mean sum of money received from family members from the matrilateral sides of the bride and groom ($M = \$260, SD = \84) was larger than that received from family members from the patrilateral sides of the bride and groom ($M = \$225, SD = \67 ; $t(29) = 2.08, p = .046$, 95% CI of the difference [0.6, 69], $d_z = 0.38$). In addition, the test was conducted separately for high (25%) and low (12.5% and 6.25%) genetic relatedness groups. Increased matrilateral investment was found in high genetic relatedness groups ($t(29) = 2.29, p = .03$, 95% CI of the difference [12, 219], $d_z = 0.42$; matrilateral $M = \$486, SD = \192 , patrilateral

$M = \$370$, $SD = \$153$), but not in low ones ($t(29) = -0.70$, $p = .49$, 95% CI of the difference $[-15, 7]$, $d_z = -0.12$; matrilineal $M = \$125$, $SD = \$40$, patrilineal $M = \$129$, $SD = \$37$). In other words, this hypothesized effect is solely operative for closer kin (genetic assuredness matters most when genetic relatedness is sufficiently high).

Discussion

Genetic Relatedness

The present study applied two evolutionary principles (kin selection and kinship certainty) in understanding gift giving in the context of Israeli weddings. We found a positive linear association between the level of genetic relatedness among wedding guests and newlyweds and the size of monetary gifts. It seems that people modulate their gift giving in accordance with the genetic relatedness to the recipient. This modulation does not require conscious awareness; kin selection may have yielded this differential solicitude via the proximate mechanism of emotional closeness (Korchmaros & Kenny, 2001). Guests with higher genetic relatedness to the newlyweds may feel closer to them and, therefore, offer larger monetary gifts. Kin selection need not be the sole explanation for the association between genetic relatedness and gift size. The normative obligation to assist close kin (Rossi & Rossi, 1990), as well as greater geographical proximity between close kin, might be operative albeit they may partially serve as proximate mechanisms of kin selection.

Although there was a positive linear trend between genetic relatedness and gift sums (H1), siblings, with a genetic relatedness of 50%, gave no more than uncles, aunts, and grandparents with a genetic relatedness of 25%. One explanation is that siblings may lack the necessary funds to offer larger gifts, as they are younger and had less time to accumulate savings (Demery & Duck, 2006). A second possibility is that the sibling relationship encompasses both

cooperation and rivalry (Pollet & Hoben, 2011), since siblings compete with one another for their parents' attention and resources, even in adult life (Taylor & Norris, 2000).

Another deviation from the general linear trend was that friends gave larger monetary gifts than the distant kin groups (6.25% and 12.5%). Saad and Gill (2003) also found that individuals were more likely to offer a larger portion of their gift-giving budget to close friends than to distant kin. Offering large gifts to friends may arise from high rates of interaction resulting in emotional closeness. Indeed, a British study (Stewart-Williams, 2008) reported that students feel more emotional closeness towards friends than toward siblings. The evolutionary importance of strong non-kin alliances via close friendships might indeed be greater than those of distant kin. This "friendship effect", nevertheless, should be interpreted with some caution since the friends were a select group of *best* friends of the newlyweds and their parents and not a representative sample of all of the non-kin guests who attended the wedding. Had data been collected on more distant non-kin as well, non-kin average gift sum may have been lower.

Matrilateral Investment

Aside from the effect of genetic relatedness on the size of monetary gifts, our study showed that matrilateral investment was greater than patrilateral investment, presumably because of differences in kinship assuredness (for other suggestions see Pashos, Schwarz, & Bjorklund, 2016). The link between kinship certainty and investment is well established in evolutionary theory. Imagine a father who lacks a preference for investing in his own children over other children. The chances that he will pass on his genes (including the genes for this non-discriminating penchant) are lower than those of a father who does discriminate. Hence, there are clear selection pressures for parental non-discrimination to be selected out.

Previous studies have demonstrated this expected matrilineal bias in grandparent investment (Chrastil, Getz, Euler, & Starks, 2006; Danielsbacka, Tanskanen, Jokela, & Rotkirch, 2011; Laham, Gonsalkorale, & von Hippel, 2005; see review in Euler, 2011). For instance, students report receiving more gifts from their maternal grandparents than from paternal ones (Bishop, Meyer, Schmidt, & Gray, 2009). A few studies have also shown matrilineal biases in the investment of uncles and aunts (Gaulin et al., 1997; McBurney, Simon, Gaulin, & Geliebter, 2002). The present results agree with the past literature based on self-reports while extending them using objective gift-giving data.

An apparent boundary condition for the matrilineal effect is that it was limited to close kin (grandparents, uncles and aunts) and was not apparent in distant kin (cousins or cousins of the parents). This makes theoretical sense in that one would expect the effect to be more operative at higher levels of kin relatedness, where investments are higher. In the literature, the effect has largely been documented for close kin such as grandparents (Euler, 2011) or uncles and aunts (e.g., Gaulin et al., 1997) with some support for more distant kin such as cousins (Jeon and Buss, 2007).

While our first hypothesis might have been posited without a detailed understanding of evolutionary principles, it is hard to imagine how the second hypothesis dealing with paternity uncertainty could have been generated void of an evolutionary lens. Therein lies one of the key epistemological benefits of incorporating principles of evolutionary psychology into consumer research, namely novel research questions are set forth that otherwise might have remained hidden from marketing scholars (Saad & Gill, 2000; Saad, 2007, 2013).

Practical Implications

Because it appears that people take genetic relatedness and kin certainty into account when offering a gift, these variables could be considered when recommending a gift purchase. This is implemented on an Israeli Internet site devoted to weddings (“Kamakesef,” 2015; “i.e., How Much Money”) that holds 25% of the wedding advertisement market share in Israel (Goldenberg, 2011). It is also applied in online gift wizards that suggest which gift to buy according to many criteria, including the relationship with the recipient (“Gift finder,” 2015, “Gift wizard,” 2015). Incorporating these types of product recommendation agents at online shopping sites might improve the quality of the purchase decision (Xiao & Benbasat, 2007).

Issues dealing with paternity uncertainty are directly relevant to several consumer-related areas that involve the differential allocation of resources to various family members. For example, perceived father-child resemblance (a means of gauging paternity certainty) shapes the amount of paternal investment that a man will provide for his offspring (Alvergne, Faurie, & Raymond, 2009; Apicella & Marlowe, 2004). Recent technological advances such as DNA paternity testing offer a nearly foolproof means for establishing the assuredness of the genetic link, and unsurprisingly such services have experienced increasing sales growth (American Association of Blood Banks, 2010). As is expected from an evolutionary perspective, women are much less keen than men to have hospitals offer this service on a mandatory basis (Hayward & Rohwer, 2004).

Future Studies

The current work is one of the first to apply an evolutionary lens in exploring family dynamics within the consumer realm (but see also Saad, Gill, & Natarajan, 2005). What of other family relationships? Maternal age predicts child investment (Tifferet, Manor, Constantini, Friedman, & Elizur, 2007) and sibling resemblance predicts sibling investment (Tifferet, Pollet,

Bar, & Efrati, 2016); can they also predict consumer behaviors such as gifting? These family dynamics and others may manifest themselves in unique ways within the consumer realm. Future consumer research should explore the Darwinian genesis of a broad range of family dynamics.

In light of the call for replications in the behavioral sciences, it might be worthwhile to conduct a conceptual replication of the matrilineal investment bias using an experimental approach. One might ask participants to offer hypothetical gift sums for matri- and patrilineal relatives based on hypothetical situations that trigger varying levels of paternity uncertainty. For example, participants might read vignettes regarding a hypothetical nephew that is about to be wed. The vignettes would manipulate the sibling's gender (is the nephew the son of the brother or sister) and the sexual promiscuity of the sibling's spouse (has the spouse of your sibling been faithful or unfaithful). Participants would be asked for the gift sum they would offer to the nephew across the various vignettes.

In the present study, we tested our hypotheses using repeated measures ANOVA. There are two major potential problems with this method (Quené & Van Den Bergh, 2004). First, repeated measures ANOVA requires the assumption of sphericity (or employing a correction). Second, it does not handle missing data successfully (Quené & Van Den Bergh, 2004). In the present study, the assumption of sphericity was violated and hence a Greenhouse-Geisser correction was applied. Nonetheless, missing data was still an issue, since each family had a different number of gifts from each of the 28 relationship categories. Although repeated measures ANOVA is adequate for simple repeated measures designs when sphericity is corrected for (Misangyi, LePine, Algina, & Goeddeke, 2006), the study results should be viewed with caution due to the small sample and the missing cases. Future studies using can benefit from hierarchical linear modeling (HLM). HLM is robust against violations of sphericity and is more

flexible in handling incomplete data. It can also allow testing more complex hypotheses. In order to utilize HLM, however, a larger number of families is needed (Maas & Hox, 2005). Other less-practiced methods of population-averaged methods can also be employed (McNeish, Stapleton, & Silverman, 2017).

Recently, leading scholars have concluded that the theoretical, methodological, cultural, and epistemological scopes of consumer research needed broadening; more integrative meta-theories were needed, and greater interdisciplinarity was welcomed (Deighton, MacInnis, McGill, & Shiv, 2010; Pham, 2013). The current paper has sought to answer this call. We have applied evolutionary theory along with a distinction between proximate and ultimate explanations (broader epistemology) to examine actual monetary gifts offered at Israeli weddings (cultural richness) using real field data (methodological pluralism). The evolutionary principles on which our hypotheses are founded stem from biology and genetics (increased interdisciplinarity). Ultimately, evolutionary theory is a complementary meta-framework capable of fostering new perspectives and engendering novel research questions.

Acknowledgments:

The first author would like to thank Alon Tifferet, Caren Weinberg, and Duli Yariv for their helpful suggestions and The Ruppin Academic Center for their financial support.

References

- Abuhav, O. (1998). Hatunat hadamim: Matanot shel hefetz ve'shel kesef behatuna Israelit [The blood wedding: Gifts of objects and money in an Israeli wedding]. In O. Abuhav, E.

- Hertzog, H. E. Goldberg, & E. Marx (Eds.), *Israel: Antropologia Mekomit [Israel: A Local Anthropology]* (pp. 571–593). Tel-Aviv: Cherrycover.
- Adar-Bunis, M. (2007). Mishpachot bereiya sociologit veantropologit. [Families in sociological and anthropological perspective]. Tel Aviv: Open University
- Alessi, G. (1992). Models of proximate and ultimate causation in psychology. *American Psychologist*, 47(11), 1359–1370. doi:10.1037/0003-066X.47.11.1359
- Alvergne, A., Faurie, C., & Raymond, M. (2009). Father–offspring resemblance predicts paternal investment in humans. *Animal Behaviour*, 78(1), 61–69.
doi:10.1016/j.anbehav.2009.03.019
- American Association of Blood Banks. (2010). *Relationship testing annual report summary for testing in 2010*. Bethesda, Maryland. Retrieved from
<http://www.aabb.org/sa/facilities/Pages/relationshipreports.aspx>
- Apicella, C. L., & Marlowe, F. W. (2004). Perceived mate fidelity and paternal resemblance predict men's investment in children. *Evolution and Human Behavior*, 25(6), 371–378.
doi:10.1016/j.evolhumbehav.2004.06.003
- Bishop, D. I., Meyer, B. C., Schmidt, T. M., & Gray, B. R. (2009). Differential investment behavior between grandparents and grandchildren: The role of paternity uncertainty. *Evolutionary Psychology*, 7(1), 66–77.
- Brumann, C. (2000). Materialistic culture: The uses of money in Tokyo gift exchanges. In M. Ashkenazi & J. R. Clammer (Eds.), *Consumption and Material Culture in Contemporary Japan* (pp. 217–240). London: Kegan Paul International.
- Burnstein, E., Crandall, C., & Kitayama, S. (1994). Some neo-Darwinian decision rules for altruism: Weighing cues for inclusive fitness as a function of the biological importance of

- the decision. *Journal of Personality and Social Psychology*, 67(5), 773–789.
doi:10.1037/0022-3514.67.5.773
- Chrastil, E. R., Getz, W. M., Euler, H. A., & Starks, P. T. (2006). Paternity uncertainty overrides sex chromosome selection for preferential grandparenting. *Evolution and Human Behavior*, 27(3), 206–223. doi:10.1016/j.evolhumbehav.2005.09.002
- Daly, M., & Wilson, M. (1980). Discriminative parental solicitude: A biological perspective. *Journal of Marriage and the Family*, 42(2), 277–288. doi:10.2307/351225
- Danielsbacka, M., Tanskanen, A. O., Jokela, M., & Rotkirch, A. (2011). Grandparental child care in Europe: Evidence for preferential investment in more certain kin. *Evolutionary Psychology*, 9(1), 3–24.
- Deighton, J., MacInnis, D., McGill, A., & Shiv, B. (2010). Broadening the scope of consumer research. *Journal of Consumer Research*, 36(6), v–vii. doi:10.1086/651925
- Demery, D., & Duck, N. W. (2006). Savings–age profiles in the UK. *Journal of Population Economics*, 19(3), 521–541. doi:10.1007/s00148-005-0039-6
- Durante, K. M., Griskevicius, V., Hill, S. E., Perilloux, C., & Li, N. P. (2011). Ovulation, female competition, and product choice: Hormonal influences on consumer behavior. *Journal of Consumer Research*, 37(6), 921–934. doi:10.1086/656575
- Euler, H. A. (2011). Grandparents and extended kin. In C. A. Salmon & T. K. Shackelford (Eds.), *The Oxford Handbook of Evolutionary Family Psychology* (pp. 181–207). New York: Oxford University Press.
- Euler, H. A., & Weitzel, B. (1996). Discriminative grandparental solicitude as reproductive strategy. *Human Nature*, 7(1), 39–59.
- Field, A. (2009). *Discovering Statistics Using SPSS* (3rd Edition.). London: Sage.

- Flynn, F. J., & Adams, G. S. (2009). Money can't buy love: Asymmetric beliefs about gift price and feelings of appreciation. *Journal of Experimental Social Psychology, 45*(2), 404–409. doi:10.1016/j.jesp.2008.11.003
- Gaulin, S. J. C., McBurney, D. H., & Brakeman-Wartell, S. L. (1997). Matrilateral biases in the investment of aunts and uncles. *Human Nature, 8*(2), 139–151. doi:10.1007/s12110-997-1008-4
- Giesler, M. (2006). Consumer gift systems. *Journal of Consumer Research, 33*(2), 283–290. doi:10.1086/506309
- Gift finder. (2013). *Find Me a Gift*. Retrieved February 3, 2013, from <http://www.find-me-a-gift.co.uk/gift-ideas-from-your-personal-shopper.asp>
- Gift wizard. (2013). *FindGift.com*. Retrieved February 3, 2013, from <http://www.findgift.com/services/gift-wizard/>
- Goldenberg, R. (2011). Competition to the Mitchatnim site. *Globes*. Retrieved February 4, 2013, from <http://www.globes.co.il/news/article.aspx?fbid=1000634988>
- Griffin, A. S., & West, S. A. (2003). Kin discrimination and the benefit of helping in cooperatively breeding vertebrates. *Science, 302*(5645), 634–636. doi:10.1126/science.1089402
- Griskevicius, V., Goldstein, N. J., Mortensen, C. R., Sundie, J. M., Cialdini, R. B., & Kenrick, D. T. (2009). Fear and loving in Las Vegas: Evolution, emotion, and persuasion. *Journal of Marketing Research, 46*(3), 384–395. doi:10.1509/jmkr.46.3.384
- Hamilton, W. D. (1964a). The genetical evolution of social behaviour. I. *Journal of Theoretical Biology, 7*(1), 1–16. doi:10.1016/0022-5193(64)90038-4

- Hamilton, W. D. (1964b). The genetical evolution of social behaviour. II. *Journal of Theoretical Biology*, 7(1), 17–52. doi:10.1016/0022-5193(64)90039-6
- Hauber, M. E., & Sherman, P. W. (2001). Self-referent phenotype matching: Theoretical considerations and empirical evidence. *Trends in Neurosciences*, 24(10), 609–616. doi:10.1016/S0166-2236(00)01916-0
- Hayward, L. S., & Rohwer, S. (2004). Sex difference in attitudes toward paternity testing. *Evolution and Human Behavior*, 25(4), 242–248. doi:10.1016/j.evolhumbehav.2004.04.001
- Hoier, S., Euler, H. A., & Hänze, M. (2001). Diskriminative Fürsorglichkeit von Tanten und Onkeln: Eine empirische Untersuchung aus evolutionspsychologischer Perspektive [Discriminative solicitude of aunts and uncles. An empirical investigation from an evolutionary perspective]. *Zeitschrift für Differentielle und Diagnostische Psychologie*, 22, 206–215.
- Jeon, J., & Buss, D. M. (2007). Altruism towards cousins. *Proceedings of the Royal Society B*, 274(1614), 1181–1187. doi:10.1098/rspb.2006.0366
- Kamakasef. (2011). *Mitchatnim*. Retrieved January 19, 2013, from <http://www.mitchatnim.co.il/kamakasef/>
- Korchmaros, J. D., & Kenny, D. A. (2001). Emotional closeness as a mediator of the effect of genetic relatedness on altruism. *Psychological Science*, 12(3), 262–265. doi:10.1111/1467-9280.00348
- Korchmaros, J. D., & Kenny, D. A. (2006). An evolutionary and close-relationship model of helping. *Journal of Social and Personal Relationships*, 23(1), 21–43. doi:10.1177/0265407506060176

- Laham, S. M., Gonsalkorale, K., & von Hippel, W. (2005). Darwinian grandparenting: preferential investment in more certain kin. *Personality and Social Psychology Bulletin*, *31*(1), 63–72. doi:10.1177/0146167204271318
- Laroche, M., Saad, G., Cleveland, M., & Browne, E. (2000). Gender differences in information search strategies for a Christmas gift. *Journal of Consumer Marketing*, *17*(6), 500–522. doi:10.1108/07363760010349920
- Maas, C. J., & Hox, J. (2005). Sufficient sample sizes for multilevel modeling. *Journal of Research Methods for the Behavioral and Social Sciences*, *1*(3), 86–92. doi:10.1027/1614-1881.1.3.86
- Marcoux, J. S. (2009). Escaping the gift economy. *Journal of Consumer Research*, *36*(4), 671–685. doi:10.1086/600485
- McBurney, D. H., Simon, J., Gaulin, S. J. C., & Geliebter, A. (2002). Matrilateral biases in the investment of aunts and uncles: Replication in a population presumed to have high paternity certainty. *Human Nature*, *13*(3), 391–402. doi:10.1007/s12110-002-1022-5
- McNeish, D., Stapleton, L. M., & Silverman, R. D. (2017). On the unnecessary ubiquity of hierarchical linear modeling. *Psychological Methods*, *22*(1), 114–140. doi:10.1037/met0000078
- Mead, R. (2008). *One perfect day: The selling of the American wedding*. New York: Penguin Books.
- Miller, G. (2009). *Spent: Sex, evolution, and consumer behavior*. New York: Viking.
- Misangyi, V. F., LePine, J. A., Algina, J., & Goeddeke, F. (2006). The adequacy of repeated-measures regression for multilevel research: Comparisons with repeated-measures ANOVA, multivariate repeated-measures ANOVA, and multilevel modeling across

- various multilevel research designs. *Organizational Research Methods*, 9(1), 5–28.
doi:10.1177/1094428105283190
- Orly, G. (2013). Osim cheshbon: Kama tirshemu bacheck lachatuna? [Calculating: How much will you write in the wedding cheque?] Retrieved August 3, 2016 from <http://www.ynet.co.il/articles/0,7340,L-4372392,00.html>
- Park, C. (1997). Consumption in the Korean wedding ritual: Wedding ritual values, consumer needs, and expenditures. *Journal of Family and Economic Issues*, 18(2), 191–209.
- Pashos, A. (2000). Does paternal uncertainty explain discriminative grandparental solicitude? A cross-cultural study in Greece and Germany. *Evolution and Human Behavior*, 21(2), 97–109.
- Pashos, A., Schwarz, S., & Bjorklund, D. F. (2016). Kin investment by step-grandparents--more than expected. *Evolutionary Psychology*, 14(1), 1–13. doi:10.1177/1474704916631213
- Pham, M. T. (2013). The seven sins of consumer psychology. *Journal of Consumer Psychology*, 23(4), 411–423. doi:10.1016/j.jcps.2013.07.004
- Pollet, T. V., & Hoben, A. D. (2011). An evolutionary perspective on siblings: Rivals and resources. In C. A. Salmon & T. K. Shackelford (Eds.), *The Oxford Handbook of Evolutionary Family Psychology* (pp. 128–148). New York: Oxford University Press.
- Quené, H., & Van Den Bergh, H. (2004). On multi-level modeling of data from repeated measures designs: A tutorial. *Speech Communication*, 43(1–2), 103–121.
doi:10.1016/j.specom.2004.02.004
- Rossi, A. S., & Rossi, P. H. (1990). *Of human bonding: Parent-child relations across the life course*. Hawthorne, NY, US: Aldine de Gruyter.

- Saad, G. (2007). *The evolutionary bases of consumption*. Mahwah, New Jersey: Lawrence Erlbaum.
- Saad, G. (2011). *The consuming instinct: What juicy burgers, Ferraris, pornography, and gift giving reveal about human nature*. Amherst, New York: Prometheus Books.
- Saad, G. (2013). Evolutionary consumption. *Journal of Consumer Psychology*, 23(3), 351–371. doi:10.1016/j.jcps.2013.03.002
- Saad, G. (in press). On the method of evolutionary psychology and its applicability to consumer research. *Journal of Marketing Research*. doi: 10.1509/jmr.14.0645
- Saad, G., & Gill, T. (2000). Applications of evolutionary psychology in marketing. *Psychology & Marketing*, 17(12), 1005–1034. doi:10.1002/1520-6793(200012)17:12<1005::AID-MAR1>3.0.CO;2-H
- Saad, G., & Gill, T. (2003). An evolutionary psychology perspective on gift giving among young adults. *Psychology & Marketing*, 20(9), 765–784. doi:10.1002/mar.10096
- Saad, G., Gill, T., & Natarajan, R. (2005). Are laterborns more innovative and non-conforming consumers than firstborns? A Darwinian perspective. *Journal of Business Research*, 58(7), 902–909. doi: 10.1016/j.jbusres.2004.01.001
- Saad, G., & Stenstrom, E. (2012). Calories, beauty, and ovulation: The effects of the menstrual cycle on food and appearance-related consumption. *Journal of Consumer Psychology*, 22(1), 102–113. doi:10.1016/j.jcps.2011.10.001
- Sherry, Jr., J. F. (1983). Gift giving in anthropological perspective. *Journal of Consumer Research*, 10(2), 157–168. doi:10.1086/208956
- Taylor, J. E., & Norris, J. E. (2000). Sibling relationships, fairness, and conflict over transfer of the farm. *Family Relations*, 49(3), 277–283. doi:10.1111/j.1741-3729.2000.00277.x

- Terian, S. K. (2004). Marriage rituals. In *Encyclopedia of religious rites, rituals and festivals* (pp. 230–236). New York: Routledge.
- The Knot real weddings survey. (2015). *The Knot*. Retrieved August 2, 2016 from <https://www.theknot.com/content/average-wedding-cost-2015>.
- Tifferet, S., Jorev, S., & Nasanovitz, R. (2010). Lower parental investment in stepchildren: The case of the Israeli “Great Journey”. *Journal of Social, Evolutionary, and Cultural Psychology*, 4(2), 62–67.
- Tifferet, S., Manor, O., Constantini, S., Friedman, O., & Elizur, Y. (2007). Parental investment in children with chronic disease: The effect of child’s and mother’s age. *Evolutionary Psychology*, 5(4), 844–859.
- Tifferet, S., Pollet, T., Bar, A., & Efrati, H. (in press). Predicting sibling investment by perceived sibling resemblance. *Evolutionary Behavioral Sciences*, 10(1), 64–70, doi: 10.1037/ebs0000035.
- Triger, Z. H. (2011). Behechlet hayitem tsrichim: Mabat chozi al tarbut matanot hachatuna beIsrael [You definitely should have: A contractual look at Israeli wedding gift culture]. *Iyunei Mishpat* [Tel Aviv University Law Review], 35(1), 51–96.
- Trivers, R. L. (1972). Parental investment and sexual selection. In B. Campbell (Ed.), *Sexual Selection and the Descent of Man 1871-1971* (pp. 136–179). Chicago: Aldine.
- Voracek, M., Haubner, T., & Fisher, M. L. (2008). Recent decline in nonpaternity rates: A cross-temporal meta-analysis. *Psychological Reports*, 103(3), 799–811.
doi:10.2466/PR0.103.7.799-811
- Webster, G. D., Bryan, A., Crawford, C. B., McCarthy, L., & Cohen, B. H. (2008). Lineage, sex, and wealth as moderators of kin investment. *Human Nature*, 19(2), 189–210.
doi:10.1007/s12110-008-9038-0

Widdig, A. (2007). Paternal kin discrimination: the evidence and likely mechanisms. *Biological Reviews*, 82(2), 319–334. doi:10.1111/j.1469-185X.2007.00011.x

WomanStats (2016). *Brideprice/dowry/wedding costs (type and prevalence)*. Retrieved August 3, 2016 from

http://www.womanstats.org/substatics/Brideprice_Dowry_Wedding_Costs_2correctstatic.png

Xiao, B., & Benbasat, I. (2007). E-commerce product recommendation agents: Use, characteristics, and impact. *MIS Quarterly*, 31(1), 137–209.

Fig. Genetic tree of the family of the bride. Square = male; circle = female; diamond = non-specified. Horizontal line connecting male and female = marriage; horizontal line connecting vertical lines = siblinghood; vertical line = parenthood. Genetic relatedness to the bride: yellow = 6.25%; green = 12.5%; blue = 25%; violet = 50%. Familial relation to the bride: F = father, FC = father's cousin, FN = father's nephew or niece, FP = father's parents, FS = father's sibling, FU = father's uncle or aunt, M = mother, MC = mother's cousin, MN = mother's nephew or niece, MP = mother's parents, MS = mother's sibling, MU = mother's uncle or aunt, S = sibling. Note that only the bride's family is shown here, the groom's tree is constructed in a parallel manner.

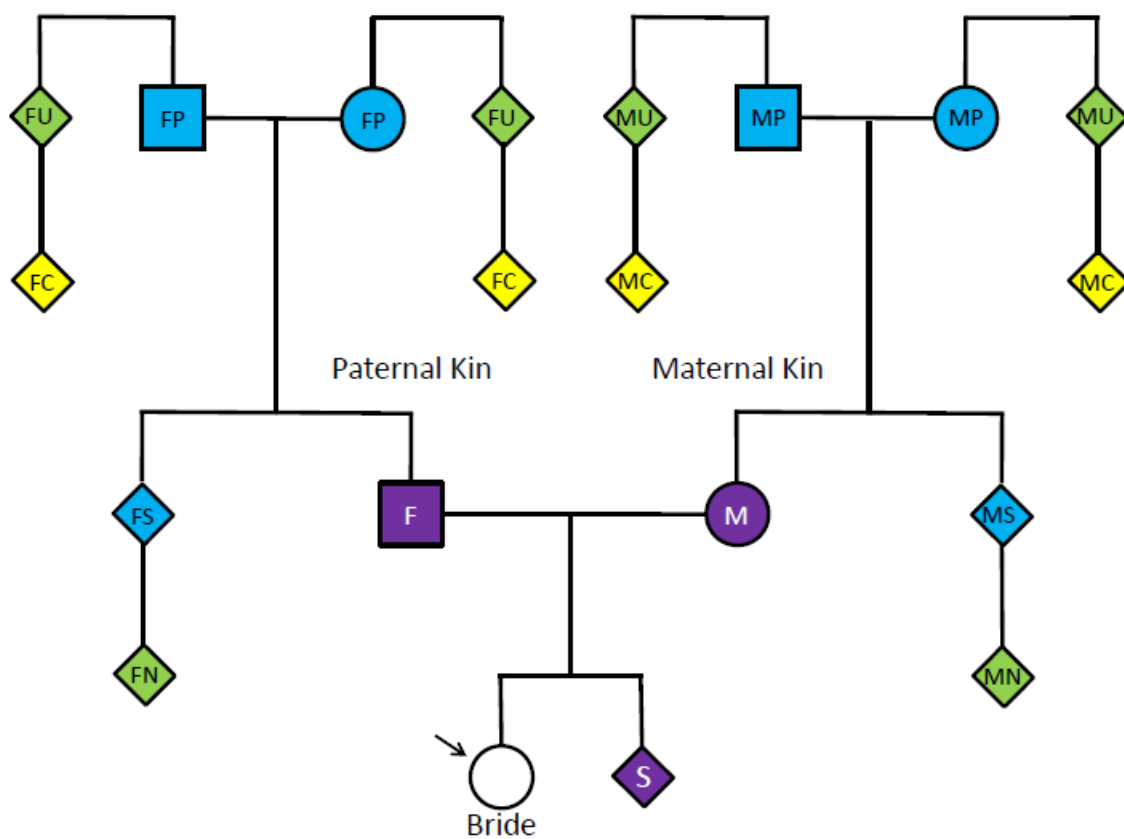

Figure 1

Table 1

Monetary Gifts Sums in USD by Genetic Relatedness ($n = 26$).

Genetic Relatedness	Relation	Mean $M (SD)$
0%	Friends, Parents' Friends	162(45)
6.25%	Parents' Cousins	122(35)
12.5%	Cousins, Parents' Uncles and Aunts	123(31)
25%	Grandparents, Uncles and Aunts	424(123)
50%	Siblings	393(133)