

Framework for Lifecycle Management of Facilities

Components Using RFID Technology

Ali Motamedi

A Thesis

in

Concordia Institute for

Information Systems Engineering

Presented in Partial Fulfillment of the Requirements

for the Degree of Master of Applied Science (Quality Systems Engineering)

at

Concordia University

Montreal, Quebec, Canada

April 2009

© Ali Motamedi



Library and Archives
Canada

Published Heritage
Branch

395 Wellington Street
Ottawa ON K1A 0N4
Canada

Bibliothèque et
Archives Canada

Direction du
Patrimoine de l'édition

395, rue Wellington
Ottawa ON K1A 0N4
Canada

Your file *Votre référence*
ISBN: 978-0-494-63161-4
Our file *Notre référence*
ISBN: 978-0-494-63161-4

NOTICE:

The author has granted a non-exclusive license allowing Library and Archives Canada to reproduce, publish, archive, preserve, conserve, communicate to the public by telecommunication or on the Internet, loan, distribute and sell theses worldwide, for commercial or non-commercial purposes, in microform, paper, electronic and/or any other formats.

The author retains copyright ownership and moral rights in this thesis. Neither the thesis nor substantial extracts from it may be printed or otherwise reproduced without the author's permission.

In compliance with the Canadian Privacy Act some supporting forms may have been removed from this thesis.

While these forms may be included in the document page count, their removal does not represent any loss of content from the thesis.

AVIS:

L'auteur a accordé une licence non exclusive permettant à la Bibliothèque et Archives Canada de reproduire, publier, archiver, sauvegarder, conserver, transmettre au public par télécommunication ou par l'Internet, prêter, distribuer et vendre des thèses partout dans le monde, à des fins commerciales ou autres, sur support microforme, papier, électronique et/ou autres formats.

L'auteur conserve la propriété du droit d'auteur et des droits moraux qui protègent cette thèse. Ni la thèse ni des extraits substantiels de celle-ci ne doivent être imprimés ou autrement reproduits sans son autorisation.

Conformément à la loi canadienne sur la protection de la vie privée, quelques formulaires secondaires ont été enlevés de cette thèse.

Bien que ces formulaires aient inclus dans la pagination, il n'y aura aucun contenu manquant.

Canada

ABSTRACT

Framework for Lifecycle Management of Facilities Components Using RFID Technology

Ali Motamedi

The AECOO (Architecture, Engineering, Construction, Owner and Operator) industry is highly fragmented; therefore, efficient information sharing and exchange between various players are evidently needed. Furthermore, the information about facility components should be managed throughout the lifecycle and be easily accessible for all players in the AECOO industry. BIM is emerging as a method of creating, sharing, exchanging and managing the information throughout the lifecycle between all the stakeholders. Radio Frequency Identification (RFID), on the other hand, has emerged as an automatic data collection and information storage technology, and has been used in different applications in AECOO. This research proposes permanently attaching RFID tags to facility components where the memory of the tags is populated with accumulated lifecycle information of the components taken from a standard BIM database. This information is used to enhance different processes throughout the lifecycle. In addition, this research suggests storing other types of BIM information (e.g., floor plans) on RFID tags which is not necessarily related to the components themselves. Having BIM data chunks stored on tags provides a distributed database of BIM and allows data access for different players who do not have real-time access to a central database. In this research, a conceptual RFID-based system structure and data storage/retrieval design are elaborated. The value adding benefits and scope of impact of the proposed approach are discussed. To explore the technical feasibility of the proposed approach, two case studies have been implemented and tested.

ACNOWLEDGEMENT

My greatest appreciation goes to my supervisor, Dr. Amin Hammad for his intellectual and personal support, encouragement and patience. His advice and criticism was my most valuable asset during my studies. Overall, I feel very fortunate having the opportunity to know him and work with him.

I would like to acknowledge the contributions of Mr. Ziad Nahas, Ms. Sonia Rodriguez, Mr. Yu Sato and Capstone project team for developing the RFID-aided inspection application and performing several field tests, Mr. Rakesh Saini for developing the location management application, Mr. Basim El-Hamwi for developing the 3D model of JMSB building, and Mr. Ayham Krayem for adding the HVAC system to the 3D model. Data collection and execution of case studies could not be done without the information provided by Concordia University Facilities Management Office. The cooperation of Mr. Jean Rivard on JMSB construction site, Mr. Gilles Desrochers from Genivar, Mr. Gerry Gallant in fire equipment inspection project and Mr. Normand Lanthier from Environmental Health and Safety Office is also appreciated.

DEDICATION

To My parents, Mehdi Motamedi and Forough Asfa and my brother Mohammad who made all of this possible, for their endless encouragement and support.

TABLE OF CONTENTS

List of Figures	x
List of Tables	xii
List of Abbreviations	xiii
CHAPTER 1 INTRODUCTION.....	1
1.1 General	1
1.2 Research Objectives and Contribution.....	3
1.3 Thesis Organization.....	4
CHAPTER 2 LITERATURE REVIEW.....	6
2.1 Background	6
2.2 Radio Frequency Identification.....	6
2.2.1 A Brief History of RFID	7
2.2.2 RFID Technology Components	8
2.2.3 Tag Types.....	9
2.2.4 Operating Frequencies	10
2.3 Building Information Model	10
2.3.1 Definition and Scope.....	11
2.3.2 BIM Data Storage, Exchange and Sharing Models	11
2.3.3 IFC Model.....	12

2.3.4	National Building Information Model Standard (NBIMS).....	16
2.3.5	Construction Operations Building Information Exchange (COBIE).....	17
2.4	Progress Monitoring and 4D Modeling.....	19
2.4.1	4D Modeling.....	19
2.4.2	Progress Monitoring and Management.....	20
2.5	Applications of RFID in the AECOO Industry.....	22
2.5.1	Material Tracking/Supply Chain.....	22
2.5.2	Construction Management.....	24
2.5.3	Quality Control	26
2.5.4	Inspection and Maintenance	27
2.6	Intelligent Products	28
2.6.1	Definitions of Intelligent Products.....	28
2.6.2	RFID and Intelligent Products	28
2.7	The Future of RFID Technology and “Internet of Things”	29
2.7.1	Outlook of the Future.....	31
2.8	Summary	32
CHAPTER 3 PROPOSED APPROACH		34
3.1	Introduction	34
3.2	System Interaction Design	35
3.3	Data Capture Methods.....	38

3.4	Conceptual Data Structure	40
3.5	BIM-Tag Data Exchange Method	44
3.6	Tag-System Data Interaction Model For Status Tracking	46
3.7	Examples of Lifecycle Location Management Using Tag Data	50
3.8	Scope of Impact and Prospective Value Adding Benefits	56
3.9	Challenges	59
3.10	Conclusions	63
CHAPTER 4 CASE STUDIES		65
4.1	Introduction	65
4.2	Case Study 1: Fire Equipment Inspection and Maintenance.....	65
4.2.1	Background of the Case Study.....	65
4.2.2	Data Gathering.....	69
4.2.3	Standard Procedure and Guidelines	70
4.2.4	Existing Procedures	72
4.2.5	Proposed System.....	74
4.3	Case Study 2: Progress Management and 4D Visualization.....	90
4.4	Summary	94
CHAPTER 5 CONCLUSIONS AND FUTURE WORK		95
5.1	Summary of Research	95
5.2	Research Contributions and Conclusions.....	95

5.3	Roadmap for Smart Building Lifecycle Management	97
5.4	Limitations and Future Work	100
	REFERENCES	101
	APPENDICES	113
	Appendix A - List of Related Publications	114
	Appendix B - Sample Maintenance Report.....	115
	Appendix C - Proposal for RFID-Aided Inspection system for Concordia University Fire and Safety Equipments	116
	Appendix D - Sample Site Visit and Test Reports.....	129
	Appendix E – Summary of Sample Hardware Test Results	135
	Appendix F -Sample GUI Interface of Developed Software	144
	Appendix G - Solving the RFID Cost-Benefit Equation.....	149

LIST OF FIGURES

Figure 2-1 RFID System.....	9
Figure 2-2 The Overall Architecture of the IFC Model (IFC Model 2009)	15
Figure 2-3 COBIE Process Overview (adopted from East, 2008).....	18
Figure 2-4 Worker Receiving Pipe Support Using RFID (Jaselskis and El-Misalami 2003)	23
Figure 2-5 Tracking and Locating Components in a Precast Storage (Ergen et al. 2007c)	24
Figure 2-6 Management of Light Weight Temporary Facility Members (Yabuki and Oyama 2007).....	25
Figure 2-7 Attaching RFID Tag on Steel Members for Progress Management (Chin et al. 2008)	26
Figure 3-1 Conceptual System Interaction Design.....	38
Figure 3-2 Conceptual BIM-Tag Data Relationship.....	38
Figure 3-3 Example of EPC ID.....	41
Figure 3-4 Process Data Update	44
Figure 3-5 RFID-System Activity Timeline.....	49
Figure 3-6 Possible Location-Related Information.....	56
Figure 4-1 Part of Floor Plan with Fire Equipments Signs.....	72
Figure 4-2 Sample Barcode for Data Entry	74
Figure 4-3 Conceptual System Design for Case Study.....	76
Figure 4-4 Design of RFID Based Inspection/Maintenance Management System	79
Figure 4-5 Snapshot of Location Management Software	81

Figure 4-6 Software Flowchart	83
Figure 4-7 Login and View Data flowchart.....	88
Figure 4-8 New Inspection/Maintenance Flowchart.....	89
Figure 4-9 System Structure	91
Figure 4-10 4D Simulation of the JMSB Project.....	91
Figure 4-11 HVAC 3D Drawing of One Floor of the JMSB Building: Construction Phase	92
Figure 4-12 HVAC 3D Drawing of One Floor of the JMSB Building: Maintenance Phase	93
Figure 5-1 Roadmap for Smart Building Lifecycle Management (Adopted from Hannus et al. 2003)	Error! Bookmark not defined.

LIST OF TABLES

Table 3-1 Conceptual Data Structure.....41

Table 4-1 NFPA-10 Timetable.....71

Table 4-3 Standard Tag Data Structure.....78

LIST OF ABBREVIATIONS

Abbreviation	Description
3D	Three-dimensional
4D	Four-dimensional
API	Application Programming Interface
BIM	Building Information Model
CAD	Computer-Aided Design
CMMS	Computerized Maintenance Management System
COBIE	Construction Operations Building Information Exchange
DoI	Digital Object Identifier
DOM	Document Object Model
IAI	International Alliance of Interoperability
ISO	International Standards Organization
EAS	Electronic Article Surveillance
EH&S	Environmental Health and Safety
EoL	End-of-Life
EPC	Electronic Product Code
ERP	Enterprise Resource Planning
GPS	Global Positioning System
GUI	Graphical User Interface
HF	High Frequency
HVAC	Heating, Ventilation and Air Conditioning
IFC	Industry Foundation Classes
Ifc-mBomb	Ifc Model Based Operation and Maintenance of Buildings
IoT	Internet of Things

IFF	Identity Friend or Foe
LF	Low Frequency
NFPA	National Fire Protection Association
NIBS	National Institute of Building Sciences
NBIMS	National Building Information Model Standard
O&M	Operation and Maintenance
STEP	STandard for the Exchange of Product model data
TIRIS	Texas Instruments Registration and Identification System
PCMCIA	Personal Computer Memory Card International Association
PDA	Personal Digital Assistant
PLM	Product Lifecycle Management
QC	Quality Control
ROI	Return on Investment
RTLS	Real-time Location Systems
UHF	Ultra High Frequency
URL	Uniform Resource Locator
USID	Ultrasound Identification
UWB	Ultra Wide Band
XML	Extensible Markup Language

CHAPTER 1 INTRODUCTION

1.1 GENERAL

Radio frequency identification (RFID) is a type of automatic identification technology in which radio frequencies are used to capture and transmit data. It acts as electronic labeling and data-collection system to identify and track items. RFID based systems have been used in different applications in construction and maintenance, such as component tracking and locating, inventory management, equipment monitoring, progress management, facilities and maintenance management, tool tracking, material management and quality control (for example Jaselskis and El-Misalami 2003, Song 2005, Ergen et al. 2007a, Kiziltas et al. 2008). However, each of the above-mentioned applications is designed for only one specific stage of the facility lifecycle to serve the needs of only one of the stakeholders in a fragmented fashion, i.e., Architects, Engineers, Constructors, Owners and Operators (AECOO). This would increase the cost and the labor for adding and removing different tags at different stages and eliminate the chance of using shared resources among the stakeholders causing duplication of efforts and resources.

This research proposes permanently attaching tags to components in the manufacturing stage as an integrated part of the components. Having the tags permanently attached, where the information on the tags is gradually updated with accumulated lifecycle information, is beneficial for all the stakeholders throughout the stages of the lifecycle, from procurement and supply chain management to maintenance and disposal.

The use of attached RFID tags for lifecycle management has been proposed in the aerospace industry for storing unique ID and important lifecycle information on tags attached to aircraft parts for enhancing inspection and repair processes. The suggested information to be stored includes the details of configuration (e.g., installation date, removal from aircraft date), details of part modifications, inspection, repair and transfer history (Harrison et al. 2006, Harrison 2007). One of the main challenges faced in this project was the assurance of the authenticity and integrity of data as well as using a standard data format for sharing information among different organizations.

Ergen et al. (2007b) proposed using RFID tags attached to engineered-to-order (ETO) components during their lifecycle and explored the technical feasibility of such system by analysing component-related information flow patterns in ETO supply chains. They also noted that integration of the data accessed with the broader information systems used across diverse organizations is an issue that needs to be investigated.

The framework introduced in this research proposes techniques to manage components' lifecycle data as well as extending the idea of RFID-attached component to other types of engineered components within a constructed facility (i.e., made-to-order and off-the-shelf components). We also propose to include broader data types on the RFID tags that are attached to building components and are spread in a building.

In the proposed approach, the information on the tags represents chunks of the Building Information Model (BIM) as a distributed database. On the other hand, RFID specific data (e.g., the unique ID) should be added to the BIM. This coupling between the BIM and the RFID information would allow reconstructing the database of the BIM (or part of

it) based on the pieces of information distributed in all the attached tags. The memory on the tags is divided into different sections, which will be gradually filled with updated information based on the current status of the component (e.g., manufactured, shipped, lifted, installed, in service, waiting for repair). Hence, the status information is the key changing information that identifies what subsystem(s) can use the data space on the tag.

The proposed approach is further explored in two case studies of a high-rise building by deploying RFID tags on selected components for improving supply chain management, locating items, installation and maintenance activities, as well as progress management and visualization.

1.2 RESEARCH OBJECTIVES AND CONTRIBUTION

The objectives of this research are: (1) to review current research on the applications of RFID technology in the AECOO industry and product lifecycle management and to survey the current status of research on BIM; (2) to investigate the idea of components lifecycle management using RFID tags populated with BIM data; (3) to investigate some detailed data interaction patterns, identifying the scope of impact and prospective value adding benefits and challenges; and (4) to demonstrate the feasibility of the proposed approach through real world case studies.

The framework introduced in this research proposes using a standard information system i.e. BIM, for lifecycle data management combined with RFID technology. This would address the need for “integration of the accessed data with the broader information systems used across organizations” (Ergen et al. 2007b) which has been identified as major challenge in previous research.

Additionally, our approach suggests storing the crucial subset of data derived from a standard information model in a distributed data storage of RFID tags that are attached to facilities components and spread in the area.

The proposed approach covers broad range of techniques to manage components' lifecycle data as well as extending the idea of RFID-attached component to other types of engineered components within a constructed facility (i.e., made-to-order and off-the-shelf components).

While other research projects mostly focus on a certain type of components or a specific lifecycle stage, our proposed approach provides conceptual data structure, data management and interaction design that can be applied for all components during the lifecycle. We also propose to include broader data types on the RFID tags that are attached to building components and are spread in a building.

1.3 THESIS ORGANIZATION

This study will be presented as follows:

Chapter 2 Literature Review: This chapter reviews the major technologies and standards that are used in the research. Literature review comprises the history of RFID technology, its components and details about different tag types and operating frequencies. BIM is covered briefly in this chapter, including data storage/exchange /sharing models, Industry Foundation Classes (IFC), National Building Information Model Standard and new standard data handover models in AECO industry. This chapter also includes the summary of major RFID-related research projects in AECO industry. Moreover, the

concept of “Intelligent Products” is discussed and major enabling technologies and outlook of the future based on available literature are elaborated.

Chapter 3 Proposed Approach: In this chapter the proposed approach for using RFID technology to support lifecycle management of facilities component is elaborated. This chapter includes the conceptual and interaction design of the system as well as the proposed data exchange method between RFID tags and BIM. In order to elaborate more on the applicability of the introduced approach, an example of lifecycle location management of components is discussed.

Chapter 4 Case Studies: In this chapter, the proposed approach is demonstrated in two case studies. In the first case study, the approach is used to facilitate lifecycle management of fire equipments at Concordia University. In the second case study RFID technology is used for progress monitoring and status visualization of new John Molson School of Business construction project at Concordia University.

Chapter 5 Summary, Conclusions, and Future Work: This chapter summarizes the present research work, highlights its contributions, and suggests recommendations for future research.

CHAPTER 2 LITERATURE REVIEW

2.1 BACKGROUND

In this chapter major technologies and standards related to RFID technology and BIM is introduced and elaborated. The emerging technologies that are discussed in this chapter support our idea in our research. Literature review comprises the history of RFID technology, its components and details about different tag types and operating frequencies. BIM is another major topic that is covered briefly in this chapter. This chapter includes the summary of major RFID-related research projects in AECOO industry based on a thorough review on available literature in different areas of the industry. The future insight of technologies and upcoming trends are discussed based on forecasts provided by major industry players and research bodies. The concept of “Intelligent Products” is discussed with major enabling technologies and an outlook of the future.

2.2 RADIO FREQUENCY IDENTIFICATION

RFID tag is a memory storage device for storing a certain amount of data such as the product identification, price and manufacturing date. This information can be read wirelessly providing the ability to process large volumes of multiple data sets simultaneously. Similar to barcodes, RFID is a technology for identifying, locating, and tracking objects. However, RFID technology introduces several advantages over barcoding in that its operation does not require line-of-sight or clean environments. RFID has been identified as one of the ten greatest contributory technologies of the 21st century. This technology has found a rapidly growing market, with global sales expected

to top US\$7B by 2008. An increasing variety of enterprises are employing RFID to improve their efficiency of operations and to gain a competitive advantage (Chao et al. 2007).

2.2.1 A BRIEF HISTORY OF RFID

Ernst F.W. Alexanderson in 1906 showed how the first radio wave could be continuously generated and how radio signals could be transmitted (Landt 2005). During World War II, the British wanted to distinguish between their own returning aircrafts and those of the enemy. They installed radio transponders on their aircrafts which was able to respond appropriately to interrogating signals from base stations. This was called the Identity Friend or Foe (IFF) system which is widely considered the first use of RFID (Dittmer 2004).

Harry Stockman (1948) published a paper entitled “Communication by Means of Reflected Power”. In 1964, R.F. Harrington examined the electromagnetic theory related to RFID in a paper entitled “Theory of Loaded Scatterers”. In the late 1960s, two companies called Sensormatic and Checkpoint together with another company called Knogo, developed the Electronic Article Surveillance (EAS) equipment to prevent the theft of merchandise (Landt 2005).

Later in 1973, large companies, such as Raytheon and RCA developed electronic identification systems. During the 70s, research laboratories and universities, such as the Los Alamos Scientific Laboratory and Northwestern University were highly involved in RFID research. The Los Alamos Scientific Laboratory, the International Bridge Turnpike and Tunnel Association (IBTTA) and the United States Federal Highway Administration

organized a conference on RFID in 1973 which concluded that there was no national interest in the development of a standard for vehicle identification (Domdouzis et al. 2007). This decision led to the development of a range of RFID related systems. In 1978, R.J. King wrote a book about microwave homodyne techniques. This book has been used as the basis for the development of the theory and practice which are used in backscatter RFID systems (Landt 2005).

The first commercial application of RFID was developed in Norway in 1987 and was followed by the Dallas North Turnpike in the United States in 1989. During the 90s, a number of American states, such as Kansas and Georgia adopted a traffic management system which was based on the use of readers that could detect RFID tags. Texas Instruments developed the TIRIS system which was used in applications related to vehicle access. European companies, such as Alcatel, Bosch and Phillips spin-off companies, such as Combitech, Tagmaster and Baumer were involved in the development of a pan-European standard for tolling applications. These companies helped develop a common standard for electronic tolling. More recently, much smaller RFID tags have been proposed. RFID tags are built in the form of labels and placed on the objects which are going to be managed (Domdouzis et al. 2007).

2.2.2 RFID TECHNOLOGY COMPONENTS

RFID technology is a wireless technology based on the detection of electromagnetic signals (McCarthy et al. 2003). A basic RFID system consists of three components: an antenna, a transceiver (with decoder) and a transponder (RF tag) electronically programmed with information. The emission of radio signals by the reader's antenna activates a tag to read or write data from/to it. The transceiver is responsible for the data

acquisition and communication. The antenna can be packaged with the transceiver and decoder in order to become a reader. The reader can be configured either as a handheld or a fixed-mount device. It can be part of other mobile computing and communication devices such as cell phones or Personal Digital Assistants (PDAs). The emission of radio waves from the reader to activate the tags can reach 100 feet or more, depending on its power output and the radio frequency. If an RFID tag is placed in the electromagnetic zone produced by reader's antenna, it detects the activation signal and responds by sending the stored data in form of electromagnetic waves. The reader decodes the data which are encoded in the integrated circuit of the tag and passes them to the host computer system for processing (Domdouzis et al. 2007, aimglobal.com 2008). A typical RFID system is shown in Figure 2-1.

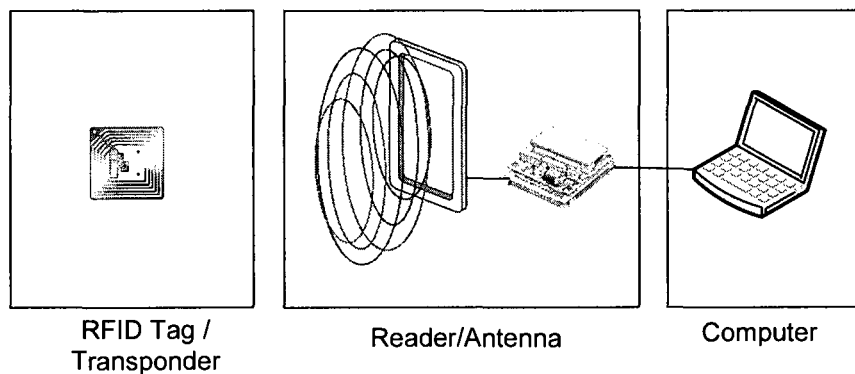

Figure 2-1 RFID System

2.2.3 TAG TYPES

Two major types of RFID tags are available: active and passive. Active RFID tags are powered by an internal battery. The memory size of an active tag varies and some tags have more than 1MB of memory. The power supplied by the internal battery of an active tag generally gives it a longer read range. Active tags are usually bigger and more

expensive than passive ones and have a limited operational life which may yield a maximum of 10 years, depending on operating temperatures and battery type (aimgloabl.com 2008).

Passive RFID tags do not need any external power source and obtain operating power generated from the reader. Passive tags are consequently much lighter than active tags, less expensive, and offer a virtually unlimited operational lifetime. The trade off is that they have shorter read ranges than active tags and require a reader with higher power.

2.2.4 OPERATING FREQUENCIES

RFID systems currently operate in the Low Frequency (LF), High Frequency (HF) and Ultrahigh Frequency (UHF) bands. Each frequency has advantages and disadvantages relative to its capabilities. Generally a lower frequency means a lower read range and slower data read rate, but better capabilities for reading near or on metal or liquid surfaces compared with higher frequencies (Scansource.com 2008).

2.3 BUILDING INFORMATION MODEL

The AECOO industry is highly fragmented in nature. Thus, it involves bringing together multi-disciplines and different parties in a project that requires a tremendous amount of coordination. This situation has resulted in significant barriers to communication between the various stakeholders, which in turn has significantly affected the efficiency and performance of the industry (Isikdag et al. 2008). Gallaher et al. (2004) indicated that US\$15.8B is lost annually in the U.S. Capital Facilities Industry due to the lack of interoperability. Consequently, there is an evident need for a standard information transfer model between different software applications used in the AECOO industry. The

BIM has been developed in order to tackle the problems related to interoperability and information integration by providing effective management, sharing and exchange of a building information through its entire lifecycle (Isikdag et al. 2008).

2.3.1 DEFINITION AND SCOPE

According to Associated General Contractors Guide (2006), BIM is a data-rich, object-oriented, intelligent and parametric digital representation of facilities. Views and data appropriate to various users' needs can be extracted and analyzed to generate information that can be used to make decisions and improve the process of delivering the facility.

NBIMS (2007a) described the scope of BIM within the following relationships: (1) BIM as a product or intelligent digital representation of data about a capital facility, (2) BIM as a collaborative process which covers business drivers, automated process capabilities, and open information standards use for information sustainability and fidelity, and (3) BIM as a facility lifecycle management tool of well understood information exchanges, workflows, and procedures which stakeholders use throughout the building lifecycle as a repeatable, verifiable, transparent, and sustainable information based environment. BIM acts as an enabler of interoperability and is a facilitator of data sharing and exchange between software applications. Furthermore, BIM is extensible, open and vendor neutral (Isikdag et al. 2008).

2.3.2 BIM DATA STORAGE, EXCHANGE AND SHARING MODELS

BIM data can be stored as a digital file or in a database, and can be shared and exchanged between several applications. The difference between data sharing and data exchange is related to ownership and centrality of data. In the data exchange model, while the master

copy of data is maintained by one software, the snapshots of data are exported to others to use. The ownership is assumed by the software that imports the exchanged data. In the sharing model, there is a centralized control of ownership and there is a master copy of data. The data sharing model facilitates the revision control issue associated with the data exchange model (Isikdag et al. 2007, Vanlande et al. 2008).

Isikdag et al. (2007) explored five different methods for storage and exchange of BIMs: (1) Data exchange by using physical files where the files are transferred using physical mediums (e.g., CD/DVD) or computer networks (e.g., Internet), (2) Data sharing by using application programming interfaces (APIs) where the BIM physical file can be accessed through proprietary or standard API based on the type of BIM in use. In case the physical file is an Extensible Markup Language (XML) file, then the model can be shared using appropriate XML interfaces (i.e. APIs supporting Document Object Model (DOM)), (3) Data sharing by using a central database that allows multiple applications to access the data and use database features such as query processing and business object creation, (4) Data sharing by using federated project databases where multiple distributed but synchronized databases can be accessed through single unified view, and (5) Data sharing by Web services where a Web service interface provides access either to the central project database where the BIM is stored, or to an API which provides access to a physical BIM file or to the domain specific views of the model.

2.3.3 IFC MODEL

The Industry Foundation Classes (IFC) standard developed by International Alliance of Interoperability (IAI) has matured as a standard BIM in supporting and facilitating interoperability across the various phases of the construction lifecycle (Isikdag et al.

2008). IFC is an object-based, non-proprietary building data model intended to support interoperability across the individual, discipline-specific applications that are used to design, construct, and operate buildings by capturing information about all aspects of a building throughout its lifecycle. It is developed as a means to exchange model-based data between model-based applications in the AECO industry, and is now supported by most of the major CAD (Computer-Aided Design) vendors as well as by many other applications (IFC Model 2008, Khemlani 2004).

The IFC effort closely parallels another collaborative representation effort known as STEP (STandard for the Exchange of Product model data). Initiated in 1984 by the International Standards Organization (ISO), STEP was focused on defining standards for the representation and exchange of product information in general, and continues to be used in various design disciplines, such as mechanical design, product design, and so on. Several people involved in STEP from the building industry realized that a more domain-specific model was needed for representing building data; they subsequently got involved with IAI and brought to it their experience in defining industry-based standards. Since IFC is an open data exchange format, it is publicly accessible to everyone and can be used by commercial applications to exchange data (Khemlani 2004).

The Overall Architecture of the IFC Model

The IFC model represents both tangible building components (e.g. walls, doors, beams) and more abstract concepts such as schedules, activities, spaces, organization, construction costs, etc. in the form of entities. Each entity can have a number of properties such as name, geometry, materials and relationships.

The architecture diagram of the IFC model is illustrated in Figure 2-2. The model is divided into four layers, representing four different levels. Each layer comprises several categories, and it is within each category or schema that the individual entities are defined. The layering system is designed in a way that an entity at a given level can only be related to or reference an entity at the same or lower level, but not an entity at a higher level. The modular design of is intended to make the model easier to maintain and grow, to allow lower-level entities to be reused in higher-level definitions, and to make a clearer distinction between the different entities so that the model can be more easily implemented in individual discipline-specific applications (IFC Model 2008, Khemlani 2004).

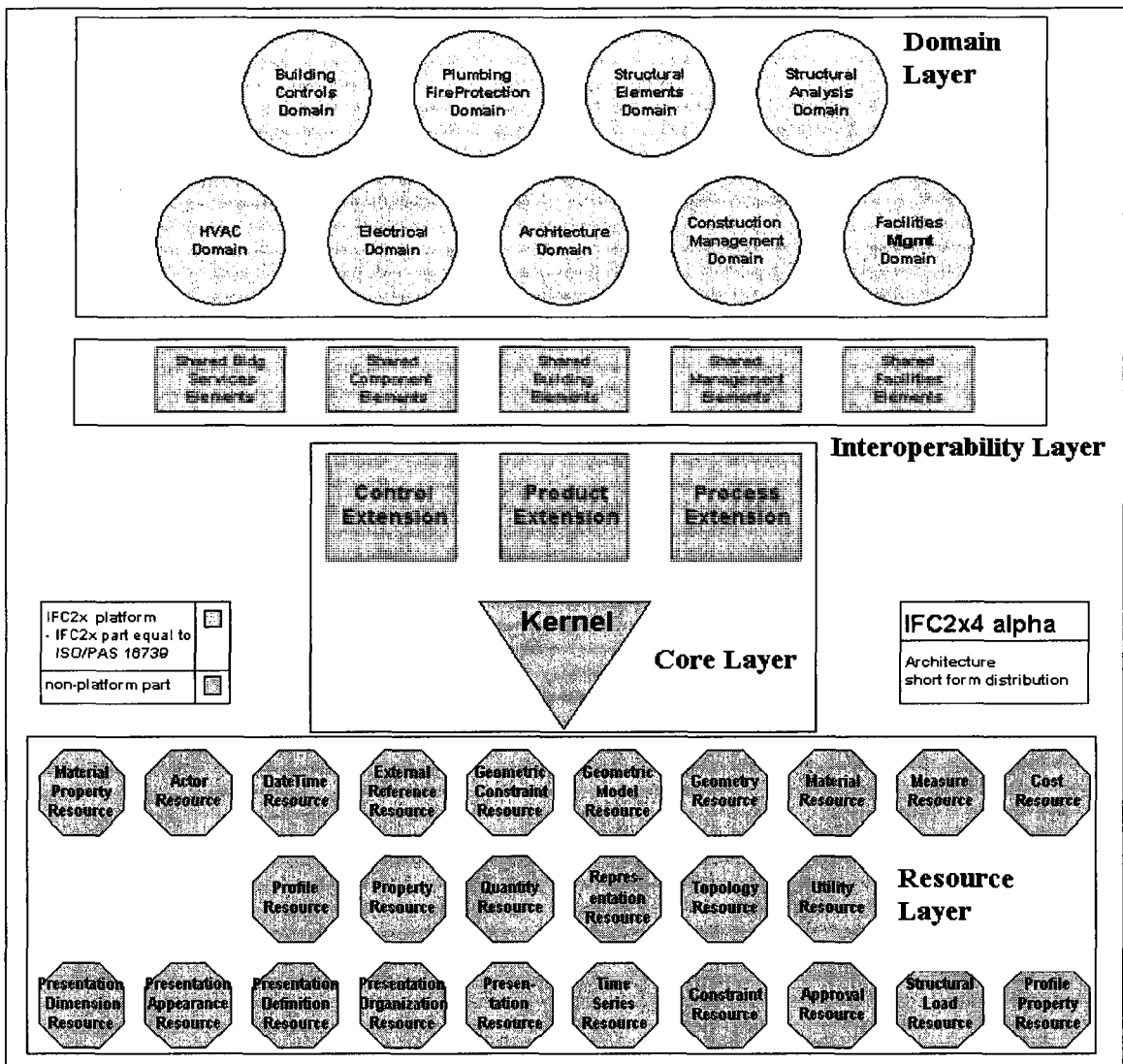

Figure 2-2 The Overall Architecture of the IFC Model (IFC Model 2009)

Brief description main layers of the IFC model architecture is as follows (Khemlani 2004):

- Resource Layer: This contains categories of entities representing basic properties such as geometry, material, quantity, measurement, date and time, cost that are generic and not specific to buildings. They function as resources that are used in defining the properties of entities in the upper layers.

- **Core Layer:** This layer contains entities that represent non-industry and industry wide specific, but abstract concepts that are used to define entities in the higher layers. For instance, the Kernel schema defines core concepts such as actor, group, process, product, relationship, and so on, which are used in all the higher-level entities of the model. The Product Extension schema defines abstract building components such as space, site, building, building element, annotation, etc. The other two Extension schemas define process and control related concepts such as task, procedure, work schedule, performance history, work approval, and so on.
- **Interoperability Layer:** This level comprises entity categories that are commonly used and shared between multiple building construction and facilities management applications. Thus, the Shared Building Elements schema has entity definitions for a beam, column, wall, door, etc.; the Shared Building Services Elements schema defines entities such as a flow segment, flow controller, fluid flow properties, sound properties, etc.; the Shared Facilities Elements schema has entity definitions for an asset, occupant, and furniture type; and so on. Most of the common building entities would be defined in this layer.
- **Domain Layer:** The highest level of the IFC model contains entity definitions for concepts specific to individual domains such as architecture, structural engineering and facilities management.

2.3.4 NATIONAL BUILDING INFORMATION MODEL STANDARD (NBIMS)

Completion of the IFC model (version 2x3) facilitated the development of exchange standards. In 2005, the Facility Information Council of the National Institute of Building

Sciences (NIBS) formed the National Building Information Model Standard (NBIMS) group. According to its charter (NBIMS 2005), the vision of NBIMS is “an improved planning, design, construction, operation, and maintenance process using a standardized machine-readable information model for each facility, new or old, which contains all appropriate information created or gathered about that facility in a format useable by all throughout its lifecycle.” One of the objectives of NBIMS group is to speed the adoption of an open-standard BIM through the definition of information exchange standards based on the IFC model (East and Brodt 2007).

2.3.5 CONSTRUCTION OPERATIONS BUILDING INFORMATION EXCHANGE (COBIE)

Construction industry contracts require the handover of various documents such as equipment lists, product data sheets, warranties and spare part lists. This information is essential to support the operations, maintenance, and management of facilities by the owner and/or property manager. In 2002, IFC-mBomb (Model Based Operation and Maintenance of Buildings) project demonstrated an approach for data capturing during design and construction, and data handover to facility operators (Stephens 2005, Ifc-mBomb 2004).

Construction Operations Building Information Exchange (COBIE) project was initiated in 2006 under NBIMS support with the objective of identifying the information exchange needs of facility managers and operators of data available upstream in the facility lifecycle (e.g., during design and construction). The COBIE team concluded that the minimum critical set of data needed by Operation and Maintenance (O&M) staff is the location, warranty duration, and parts suppliers for installed equipment (East and Brodt 2007).

COBIE simplifies the work required to capture and record project handover data by recording the data as it is created during design, construction, and commissioning. Designers provide floor, space, and equipment layouts. Contractors provide make, model, and serial numbers of installed equipment. Much of the data provided by contractors comes directly from product manufacturers who can also participate in COBIE (East 2008). Figure 2-3 shows COBIE process overview where various data are transferred between main phases of the lifecycle.

While COBIE is designed to work with the BIM, COBIE data may also be created and exchanged using simple spreadsheets. The COBIE team selected spreadsheets so that the benefits of the COBIE approach can be widely used throughout the facility acquisition industry, not just on large, high-visibility projects (East 2008).

The COBIE Pilot implementation standard was published as Appendix B of the NBIMS (NBIMS 2007b). The underlying IFC model description of the COBIE pilot standard was also published for international evaluation (IDM 2007).

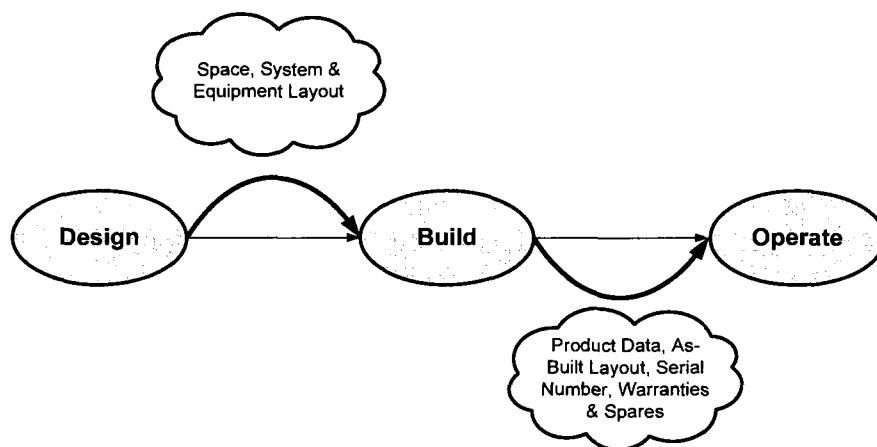

Figure 2-3 COBIE Process Overview (adopted from East, 2008)

2.4 PROGRESS MONITORING AND 4D MODELING

2.4.1 4D MODELING

Traditional labour-intensive construction industry has been revolutionized slowly by modern Information Technology. The application of 3D CAD provides significant reductions in cost growth, schedule slippage, and total rework (CII 1995). 3D visualization is becoming an important tool in construction projects management. Some construction contractors use Virtual Reality to check construction feasibility.

Four-dimensional (4D) models link 3D construction models with timing information of the construction schedule to simulate construction operations and the assembly sequence. The visual presentation of the schedule and construction site conditions is capable of facilitating decision making during both the planning and construction stages. With 4D visualization of the construction sequence, construction planners are able to develop a more finely tuned construction schedule by resolving schedule conflicts in advance. Feedback from reviewing the 4D construction model has often led to a more readily constructible, operable, and maintainable projects (Simons et al. 1988, Williams 1996, Rischmoller et al. 2001, Griffis et al. 2001). In addition, 4D visualization has the potential of promoting collaborative work and assisting in site layout planning (Hu et al. 2005, Kang et al. 2007).

Kang et al. (2007) identified several construction projects which have demonstrated that 4D visualization of the construction sequence is a valuable tool to help project participants understand the construction schedule and intuitively identify potential conflicts and special challenges of the job site before the project begins. Among them are

the San Mateo County Rehabilitation Center campus expansion project (Collier and Fischer 1996) and the Walt Disney Concert Hall project (Goldstein 2001, Post 2002). The design and construction of Helsinki University of Technology Auditorium Hall 600 demonstrated that 4D visualization of the construction sequence fostered early communication among the end users and owners. As a result, designers and engineers captured valuable inputs from the clients and merged them effectively into the design work (Fischer and Kam 2002). Meanwhile, Kamat and Martinez (2001) explored the merit of visualizing the results of construction simulation to better express the unit construction operations (Kang et al. 2007).

2.4.2 PROGRESS MONITORING AND MANAGEMENT

Accurate progress management is one of the important success factors for project management in that it enables the management to forecast risks and to take corrective actions by monitoring project status. Various progress measurement and management methods were proposed in previous studies (e. g. Thomas and Mathews 1996, CII 1987, Fleming and Kopplemna 1996). However, the existing progress measurement methods have limits on accuracy and reliability due to ad-hoc measurements based on the personal experience of the project manager (Yoon et al. 2006).

Furthermore, creating reliable look-ahead schedules and updating that schedule using accurate and prompt assessment of project status is critical in successful completion of construction projects. Updating a given schedule involves capturing current project status from a construction site, comparing it with what was expected based on a given schedule, identifying and learning from possible deviations between the actual and the expected project status, and reflecting what have been learned to scheduling of upcoming

activities. Hence, to enable better decision making during schedule update, it is important to capture relevant project facts (e.g. processes being completed, conditions under which they got completed, resource conditions, etc.) promptly and accurately. During schedule updating, schedulers fuse the production and resource utilization data for completed activities. Hence, integration of the facts captured from a site digitally is necessary for easy navigation through the set of captured facts, assessment of a given project status comprehensively and learning from these facts (Kiziltas and Akinci 2005).

Meanwhile, RFID has emerged as a technology that can be effectively applied for real time measurement of project information in the construction industry. It is expected that RFID will overcome the limits on progress management (Jaselskis et al. 1995, Jaselski and El-Misalami 2003, Yagi et al. 2005, Song et al. 2005, Goodrum et al. 2006, Chin et al. 2005).

Chin et al. (2005) introduced new applications for progress management and discussed the usability of RFID to build a project progress management framework by integrating 4D CAD with RFID technology under a collaborative environment through the supply chain of project. In their research a system was proposed that renders building elements in a 3D model according to as-built progress, where the as-built information is collected in real-time by sensing the progress throughout the supply chain using RFID. They focused on structural and curtain wall elements, such as steel columns and beams, concrete slabs, and curtain walls, which are typically on the critical paths of project schedules in high-rise building construction projects. The motivation for choosing the mentioned items was that steel structures and curtain walls in high-rise building construction projects are among the major work items that require more intensive

progress management. They occupy a fair portion of the total project cost, and their activities are on the critical path. Since high-rise building construction projects are located in downtown areas, space to stock components and materials is very limited. Based on their research it is necessary to have an information system that supports progress management through the supply chain among project participants. Also, progress data in the supply chain needs to be collected and incorporated into the information system in a fast and accurate way so that project participants can manage and collaborate more efficiently and effectively (Chin et al. 2005).

2.5 APPLICATIONS OF RFID IN THE AECOO INDUSTRY

While RFID technology has significant beneficial applications in manufacturing, retailing, transport and logistics industries, its potential applications in the AECOO industry have only begun to be explored (Song et al. 2006). The main usage of RFID is in supply chain management and the tracking of materials, components, workers and equipment in construction projects (Jaselskis et al. 1995, Jaselski and El-Misalami 2003, Chin et al. 2005, Song et al. 2005, Ghanem and Abdelrazig 2006, Goodrum et al. 2006, Yoon et al. 2006). However, some researchers have proposed using RFID for tracking components during inspection and maintenance activities (SAP 2005). The research on applications of RFID in AECOO industry can be roughly categorized as follows:

2.5.1 MATERIAL TRACKING/SUPPLY CHAIN

Jaselskis et al. (1995) discussed an RFID system for tracking concrete delivery vehicles. Their proposed system would ensure proper delivery, billing and quality control of concrete. Song et al. (2006) tested RFID tags for tracking the delivery and receipt of pipe spools on the construction site.

Jaselskis and El-Misalami (2003) also performed pilot tests in which passive RFID tags were used in the receiving process of pipe hangers and pipe supports at job site laydown yards Figure 2-4. The pilot tests demonstrated the usefulness of the technology in receiving the unique engineered materials, but the fact that the RFID handheld reader had to be within a few inches of a tag for proper reading was considered as technical difficulty (Song et al. 2006a).



Figure 2-4 Worker Receiving Pipe Support Using RFID (Jaselskis and El-Misalami 2003)

RFID technology is proposed for tracking construction components through a supply chain. Akinici et al. (2002) and Ergen et al. (2003) proposed the use of RFID technology in tracking precast concrete pieces and storing information associated with them through a supply chain.

The combination of RFID technology with the Global Positioning System (GPS) has been investigated in projects in which the materials that are tagged can be automatically

identified and tracked on construction sites by field supervisors or material handling equipment that are equipped with an RFID reader and a GPS receiver (Song et al. 2006b). As shown in Figure 2-5, RFID was used in conjunction with GPS for tracking and locating components in a precast storage yard (Ergen et al. 2007c).

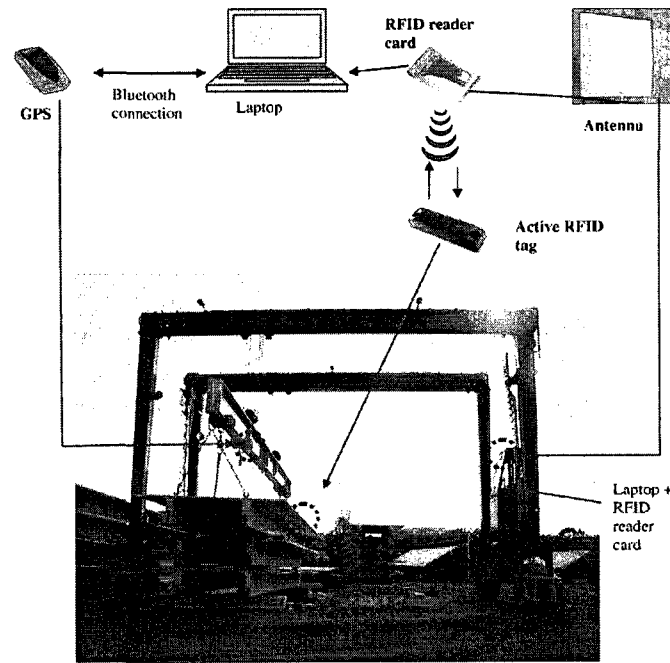

Figure 2-5 Tracking and Locating Components in a Precast Storage (Ergen et al. 2007c)

2.5.2 CONSTRUCTION MANAGEMENT

For identification and tracking of construction components on site, Furlani and Pfeffer (2000) developed a prototype system based on an overall system architecture proposed by Furlani and Stone (1999). In their proposed system, different technologies, (e.g., barcoding, RFID and 3D scanning laser systems) were used for the identification and tracking of tagged structural steel components.

Furlani et al. (2000) attached tags to structural steel members on the construction site to track them and used the identification information on the tags to query a project database for additional information related to the scanned items, such as the 3D CAD model of the steel part.

RFID tags have been used to track assets and to provide security on the construction site by monitoring the site and alerting the site managers when an item has been taken away from the site (Domdouzis et al. 2007, FIATECH 2008). Goodrum et al. (2006) explored the application of active RFID for tool tracking on construction sites. Furthermore, Yabuki and Oyama (2007) studied the application of RFID for the management of light-weight temporary facility members (Figure 2-6).

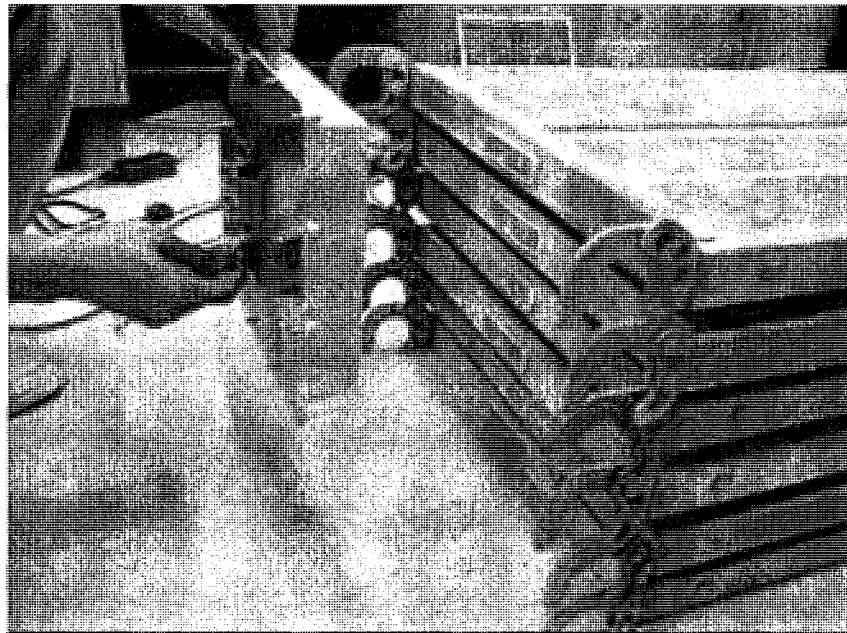

Figure 2-6 Management of Light Weight Temporary Facility Members (Yabuki and Oyama 2007)

Yagi et al. (2005) proposed the concept of “parts and packet unification” in which unique ID is stored on construction components’ tags to control and enhance the production and assembly processes. Umetani et al. (2006) demonstrated the feasibility of their method using a module assembly experiment.

Several researches discussed the usability of RFID to build a project progress monitoring framework by integrating 4D CAD with RFID technology under a collaborative environment through the supply chain of a project (Hammad and Motamedi 2007, Chin et al. 2005, 2008 , Ghanem and Abdelrazig 2006). Figure 2-7 shows the process of attaching RFID tags to steel members in order to facilitate the process of progress monitoring in construction projects.

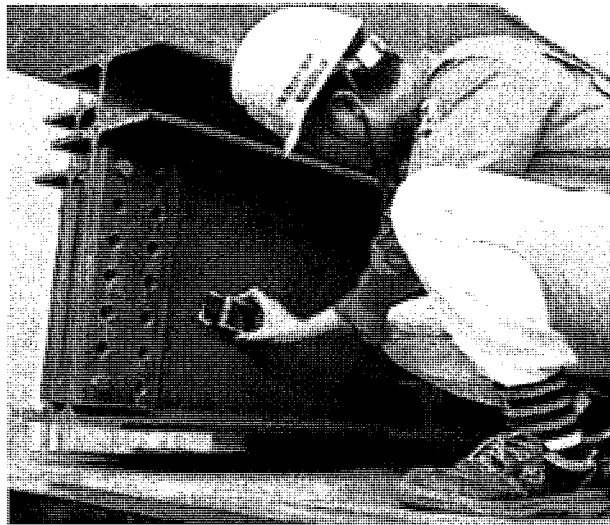

Figure 2-7 Attaching RFID Tag on Steel Members for Progress Management (Chin et al. 2008)

2.5.3 QUALITY CONTROL

Peyret and Tasky (2002) used RFID technology to track the delivery vehicles of plant mixed asphalt for quality control purposes. Production data related to a batch of asphalt

were automatically collected on an RFID tag mounted on the asphalt hauling truck and transferred to the asphalt paver on site, while the position of a particular batch of asphalt being laid was provided by the GPS receiver mounted on the paver (Song et al. 2006a).

Yabuki and Oyama (2007) used passive UHF tags to track records of actual usage period of light temporary facility members such as pipes, scaffolding plates and frames.

2.5.4 INSPECTION AND MAINTENANCE

Schell (2001) reported a pilot test at California oil refinery plant where the rugged RFID tags were attached to pressure relief valves in order to improve the maintenance process. In this project, the annual re-certification information of the valves were simultaneously written to the tags and recorded in the maintenance facility's database. Then, the valves were returned to the refinery with the RFID tags populated with the new certification information. Yabuki et al. (2002) suggested an on-site inspection support system by using a combination of RFID tags and PDAs. They attached RFID tags to specific facility components and stored the latest inspection information and measured data on them. Ergen et al. (2007a) determined the technological feasibility of using UHF active tags during the operation and maintenance phase by repetitively testing the tags attached to fire valves over an extended period of time. RFID technology has been widely implemented at Fraport airport (Legner and Thiesse 2006) where almost 22,000 fire shutters have been equipped with protected RFID tags to store maintenance history. Yabuki et al. (2004) studied the application of RFID in the inspection of a large dam. 68 RFID tags were attached to various members, equipments and measuring devices at Haneji Dam in Okinawa, Japan for supporting inspection activities.

2.6 INTELLIGENT PRODUCTS

2.6.1 DEFINITIONS OF INTELLIGENT PRODUCTS

McFarlane et al. (2003) defined an Intelligent Product as a physical and information-based representation of a product. An Intelligent Product has the following properties:

- (1) Possesses a unique identification.
- (2) Is capable of communicating effectively with its environment.
- (3) Can retain or store data about itself.
- (4) Deploys a language to display its features, production requirements, etc.
- (5) Is capable of participating in or making decisions relevant to its own destiny.

Based on this definition, Wong et al. (2002) have defined a two level classification of intelligence. When the Intelligent Product only covers first three points, it is information oriented, and is called a product with level 1 product intelligence. A product with level 2 product intelligence covers all points, and is called decision oriented. Even though this Intelligent Product classification is quite generic concerning the level of intelligence of an Intelligent Product, it is based on a separation between the actual product and its information-based counterpart. Therefore, it is mainly intended for describing the use of RFID technology in for example manufacturing and supply chain purposes, without covering for instance products with embedded processing and communication capabilities (Meye et al. 2009).

2.6.2 RFID AND INTELLIGENT PRODUCTS

Intelligent Products were first analysed in an after sales and service context. later the idea of integrating intelligence and control into the product spread to manufacturing

(McFarlane et al. 2003) and supply chain control (Karkkainen 2003). In these application domains, new Auto-ID technologies, such as RFID, have made the tracking and tracing of products throughout the entire supply chain possible. When product in a logistic/production setting is given a traceable individuality together with the associated content (e.g. delivery terms, contract terms, etc.), and also decision power is delegated to it, we enter the realm of Intelligent Products (Meye et al. 2009).

Such Intelligent Products will have the means to communicate between themselves and also with logistic service providers. Intelligent Products link the Auto-ID technology to the agent paradigm and Artificial Intelligence.

Furthermore, Intelligent Products can also play an essential role in product lifecycle management by their potential of collecting usage information and proactively reacting on it, e.g. estimating needs for maintenance or repair (Motamedi and Hammad 2009, Meye et al. 2009).

What is common to such tracking and tracing in the supply chain and to product lifecycle management is that information needs to be represented at the item level and communicated between different organizations. Therefore, there is increasing interest in the development of Auto-ID technologies and Intelligent Products which is being reflected in on-going work, current project proposals and future research areas (Meye et al. 2009).

2.7 THE FUTURE OF RFID TECHNOLOGY AND “INTERNET OF THINGS”

Internet of Things (IoT) can be defined as “Things having identities and virtual personalities operating in smart spaces using intelligent interfaces to connect and

communicate within social, environmental, and user contexts”. A different definition, that puts the focus on the seamless integration, is “Interconnected objects having an active role in what might be called the Future Internet” (EPoSS 2008).

A fundamental enabler would be the identity knowledge, of the “self” and of the others. Enabling the object to know “itself” and its common properties such as creation, recycling, transformation, ownership change, or use for different purposes will allow common objects to interact actively and decisively with the environment.

There are several technologies that are contributing to the development of new emerging concept of IoT their developments are considered as high priority. For example, energy harvesting and low-power chipsets with capabilities such as context awareness and inter-machine communication and multi frequency band antennas.

Moreover, integration of smart devices into packaging, or better, into the products themselves will allow a significant cost saving and increase the eco-friendliness of products. Future tags must integrate different communication standards and protocols that operate at different frequencies and allow different architectures. Hence, open standards are key enablers for the success of the IoT, as it is for any kind of machine to machine communication (EPoSS 2008, ITU 2005).

Standards evolution and interoperability will influence the RFID deployments in the near future and the viability of the IoT in the long term. Sustainable fully global, energy efficient communication standards that are security and privacy centered and are using compatible or identical protocols at different frequencies are therefore needed. Manufacturing challenges must be convincingly solved. Costs must be lowered to less

than one cent per tag, and production must reach extremely high volumes, while the whole production process must have a very limited impact on the environment (ITU 2005, EPoSS 2008).

There are also barriers in implementing the idea of IoT that should be considered, for example, without an impartial governing authority it will be impossible to have a truly global “Internet of Things”, accepted by states, companies, trade organizations and the common people. Also the privacy and security has a major importance and the public acceptance for the internet of the things will happen only when the strong security and privacy solutions are in place.

2.7.1 OUTLOOK OF THE FUTURE

In the coming years, technologies necessary to achieve the ubiquitous network society are expected to enter the stage of practical use. It is widely expected that RFID technology will become mainstream in the retail industry around 2010 (EPoSS 2008).

Traditionally, the retail and logistics industry require very low cost tags with limited features; such as an ID number and some extra user memory area, while other applications and industries will require tags that will contain a much higher quantity of data and more interactive and intelligent functions. “Data”, in this context, can be seen as an “object” and under this vision a tag carries not only its own characteristics, but also the operations it can handle. The amount of intelligence that the objects in the IoT will need to have and if, how and in which cases this intelligence is distributed or centralized becomes a key factor of development in the future. In the context of greater “wireless”, “mobility”, “portability” and “intelligence” two trends will influence the future

development of smart systems: the increased use of “embedded intelligence” and the networking of embedded intelligence.

Other topics for research include not only the integration of electronic identifiers into materials, such as ceramics, metals, or paper, but also the creation of devices from non-silicon based materials, such as, for instance, edible tags. This will allow, for instance, embedding tags into medicines, which can be seen as a giant step to putting receivers into packaging. Additionally, the future IoT will have to be built within recyclable materials and therefore have to be fully eco-friendly. Future smart objects must also be power independent, harvesting energy from the environment in which they operate (EPoSS 2008).

2.8 SUMMARY

In this chapter several technologies, standards and applications related to RFID and BIM were reviewed. Moreover, the insight for the future state of the above mentioned technologies based on forecasts and trends was elaborated.

The literature showed that RFID technology has the potential to facilitate several operations during the lifecycle of products. On the other hand BIM and related standards are emerging to tackle the interoperability and data management issues in the highly fragmented AECOO industry. BIM and RFID can work together as complimentary technologies. This idea is central to our proposed approach and is introduced in this research as a new opportunity for lifecycle management where RFID acts as distributed BIM data storage and provides information for several applications during the lifecycle of

components. Our proposed approach is based on this thorough review of related technologies and standard.

CHAPTER 3 PROPOSED APPROACH

3.1 INTRODUCTION

The lifecycle of a building can be divided into four main stages which are: design, construction, operation and maintenance and decommissioning/disposal/recycling/reuse. Each stage is generally managed independently and is divided into superimposed layers. Each layer has its own information and also exchanges partial information with other layers. In addition, the constructed facility is composed of various components that must be managed through the above mentioned stages. Thus, the information related to each component should be tracked separately throughout the lifecycle. Furthermore, the information should be in a convenient format and stored at a suitable location to enable all the stakeholders to efficiently access throughout the lifecycle. Effective and immediate access to information minimizes the time and labour needed for retrieving information related to a component and reduces the occurrence of ineffective decisions that are made in the absence of information (Ergen et al. 2007b).

The need for providing easy-to-access product and process related information for all stakeholders has resulted in various BIM standards such as NBIMS as discussed in Subsection 2.3. Centrally stored information that is accessible electronically over a computer network is a solution for data access. However, having real-time access to information could be difficult since reliable connections to the central data storage may not be always available. Furthermore, downloading the relevant data for the desired component or process from a central database could be a complicated and time consuming task.

This research proposes adding structured information to tags attached to the components by using RFID technology that provides the data storage capacity on the tags. Having the essential data related to the components readily available on the tags provides easy access capability for whoever needs to access the data regardless of having real-time connection to the central database or having a local copy of the required information.

The ability to store information in digital format on the components can provide “level one product intelligence” for the components (Ergen et al. 2007b). Since an RFID tag can be used to store the above information and is capable of communicating wirelessly with the environment, it is considered to be capable of adding such intelligence to the component. Moreover, this distributed memory space of the tags can store information not only related to the component itself but also related to processes or environment data, and can function as a distributed database.

Based on the proposed approach, RFID tags are attached to a selection of building components such as HVAC (Heating, Ventilation and Air Conditioning) control units, boilers, etc. It is assumed that the RFID tags can be sensed from relatively long distance and can store several kilobytes of data. The data to be stored on the tags are derived from a BIM database, based on the size of memory and the stage of the component in its lifecycle.

3.2 SYSTEM INTERACTION DESIGN

In our proposed approach, every component is a potential target for tagging. The RFID tags can be attached to components or, based on the uprising IoT trends, could be

integrated in the components as an integral part (EPoSS 2008). Having standard tags attached to components would result in a massive tag cloud in the building.

While having tags attached to all components would not happen in the immediate future, in order to benefit from the concept of having identity and memory tags on a mass of items, the subset of components to be tagged can be selected based on a cost-benefit analysis. Appendix G provides general guidelines for performing Cost-Benefit analysis. The selection of the components for tagging is based on the scale of the project, types and values of the components, specific processes applied to these components (i.e., acquiring, assembling, constructing, inspecting, maintaining), and the level of automation and management required by the facility owners.

The information stored in this fragmented memory space can be used to facilitate different processes as will be discussed in Subsection 3.6. The system design, including the data structure model and data acquisition method, is general for all components. The target components are tagged during or just after manufacturing and are scanned at several points in time. The scan attempts are both for reading the stored data, or modifying the data based on the system requirements and the stage at which the scan is happening.

The scanned data are transferred in real time to different software applications and processed to manage the activities related to the components. Figure 3-1 shows the conceptual design for interaction between different system components. The generic software application communicates with RFID tags by using the reader API and stores and retrieves the lifecycle data to/from a central BIM database. The RFID specific

information is added to the BIM database in the design phase as part of the product information. This information includes: the ID, type of the tag, location of the tag on the component and memory/RF specifications. The BIM implementations should be extended to contain this information.

The memory of the tag contains a subset of BIM information. While the BIM database is being populated by information by different software applications throughout the lifecycle, the tag memory space is modified and updated as the component is scanned. The amount of information that should be written on a tag is related to the available memory of the tag and the stage of lifecycle that the component is in. Some of this information is permanent, such as the ID which is the key information for the identification of the component in the database. In contrast, some BIM information chunks are stored on the tags only for a specific lifecycle stage where the information is useful for specific processes, such as installation instructions which are useful only during the installation stage. The types of information that can be stored on the tags will be discussed in detail in Subsection 3.4. Figure 3-2 conceptually shows how BIM data chunks are stored on tags attached to the building components. While the information is centrally stored in the BIM database, software applications copy the necessary information from the database to the memory space on the tags.

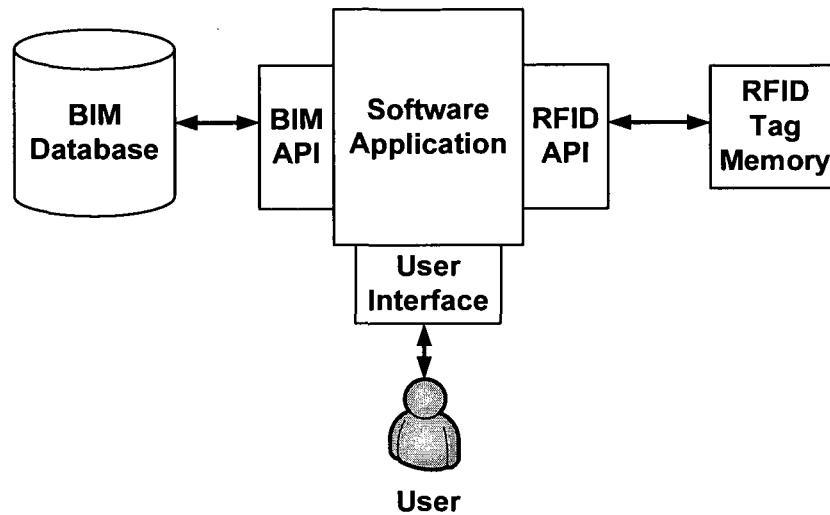

Figure 3-1 Conceptual System Interaction Design

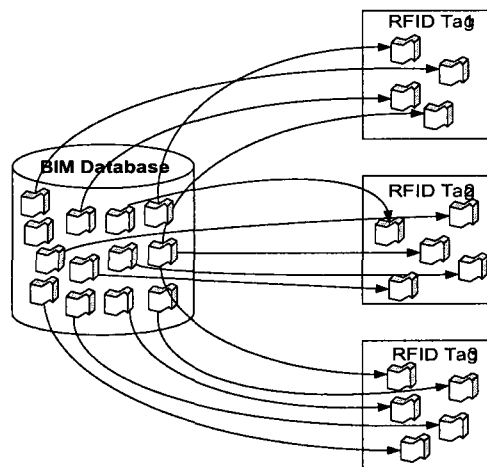

Figure 3-2 Conceptual BIM-Tag Data Relationship

3.3 DATA CAPTURE METHODS

The structured data stored on the tags should be read, updated and changed by several RFID-based systems during the lifecycle. These modifications are executed by different types of RFID readers. In order to identify the suitable type of reader for each scan

attempts, the detailed process requirements should be captured, such as the readability range, data transfer rate and portability.

In general, building components can be categorized into three groups: (1) fixed components in the structure (e.g., walls, HVAC parts), (2) movable components (e.g., Fire extinguishers, or fixed component before installation) and, (3) temporary components that are used during the construction (e.g., scaffoldings). There are also two types of readers that could be used for data interaction with the tags: stationary readers and mobile readers. Stationary readers can be located at the gates or any designated place within the facility to detect moving components. Mobile readers can be used to interact with both movable and fixed components.

The data stored on the components can be read from different distances. The maximum readability distance depends on various factors, such as power level of reader, antenna type and size, frequency range and environmental factors. In some applications, it is desirable that the data be read from far distance. Hence, the system can detect the component, and related information can be read even if the component is hidden or not visible. If the location data is stored on the tag (for the fixed components) or the tag has a positioning sensor (e.g., GPS), the ability to read the data from a distance provides the required information to locate them. Other applications may require shorter readability. For example, if the tags are used to facilitate inspection activities, having short read/write range would guaranty that the inspector was in the required proximity of the component.

In the proposed approach, RFID tags are fixed to components; therefore, tags should be designed to have the maximum possible range and protection from noise and

interference. However, it is always possible to control read/write range on the reader based on the process requirements.

The fact that multiple tags can be simultaneously read with no line of sight provides large time reduction for detection and data capture. However, having too many tags will cause interference and increase the noise level. There are several detailed design challenges for different applications that should be tackled and will be discussed in detail in Section 3.9.

3.4 CONCEPTUAL DATA STRUCTURE

As discussed in Subsection 3.2, in our proposed approach, lifecycle information are centrally stored in a BIM database and a subset of this information is stored on the tags. The BIM database contains information related to building components and lifecycle processes in addition to information related to the environment of the component. As discussed above, considering the limited memory of the tags, the subset of data stored on the tags has to be chosen based on the requirements. While data on a tag are changing during the lifecycle of the component and different software applications use and modify the data with different designated access levels, the memory of the tag should be virtually partitioned in a structured fashion based on predefined data types. This structure would also allow further expandability and facilitate the process of data management. In addition, it provides the required segmentation hierarchy needed for implementing different levels of data security and encryption. Furthermore, the ownership of the memory partitions and the read/write access should be designated to appropriate software applications based on the component's lifecycle stage and security/access levels.

We propose to virtually partition the memory space into the following fields as shown in Table 3-1: (1) ID, (2) specifications, (3) status, (4) process data, (5) history data, and (6) environment data.

Table 3-1 Conceptual Data Structure

Field	ID	Specifications	Status	Process Data	History Data	Environment Data
Description	Unique identifier	Component specifications	e.g., installed, shipped, assembled	Data related to current stage of component in the lifecycle	Accumulated, event driven data recorded during the lifecycle	Data related to component's environment

ID

In order to look up the component in the BIM database, there is a need to have a non-changeable, unique identifier (ID) for each component. There are standard coding schemes that can be used for providing structure for the ID. One of the most referred and implemented schemes is EPCglobal (Electronic Product Code) Tag Data Standards (EPCglobal 2008). The EPC typically consists of three ranges of binary digits (bits) (Harrison et al. 2004): (1) an EPC manager (often the manufacturing company ID), (2) an object class (usually the product line or Stock Keeping Unit), and (3) a unique serial number for each instance of a product. Figure 3-3 shows an example of EPC ID.

01.0000A89.00016F.0024579DC

Header EPC Manager Object Class Serial Number

Figure 3-3 Example of EPC ID

Specifications

This field is dedicated to specifications of the component derived from the design and manufacturing stage of the lifecycle. The information of this portion should remain with the component throughout its lifecycle. Safety related information and hazardous material information are examples of specifications.

Status

Status field identifies the current main stage (e.g., in service, installed, manufactured, and assembled) and sub-stage (e.g., in service: waiting for inspection) of lifecycle of the component. The status information is used to decide which software application can use and modify the data in the process data field.

Process data

This field is relatively large compared to the other fields and is designed to store the information related to the component's current stage of the lifecycle. The data related to current processes to be stored on the tags are different and should be changed during the lifecycle. For example, assembling instructions are used only in the assembly stage. Therefore, the process data field contains only information related to the current lifecycle stage taken from BIM database. Moreover, the ownership (ability to read, modify or change) of the process data, should be restricted to one or a group of applications (e.g., inspection management software, installation management software) that are involved in that specific stage. The ownership of the process data field is decided based on the status field as explained above.

Figure 3-4 shows how different software applications modify the process data field. Different applications use the same memory space but at different lifecycle stage. Figure 3-4 demonstrates a sample component that follows a specific lifecycle pattern where BIM information is copied by different software applications on the memory of its RFID tag.

History data

This field is designated for storing the history data used during the lifecycle for maintenance and repair purposes. The history records are derived from BIM and accumulated during the lifecycle to be used in forthcoming stages.

Environment data

This field is designated for storing environment specific data, such as the location or the usability and specifications of the space. Hence, environment data field contains all the information that is not related to the component itself. The environment data is also taken from BIM but it contains the information coded under concepts such as “spaces” in BIM. Examples of environment data are: functionality of the space that the component is in, occupants’ data and floor plan.

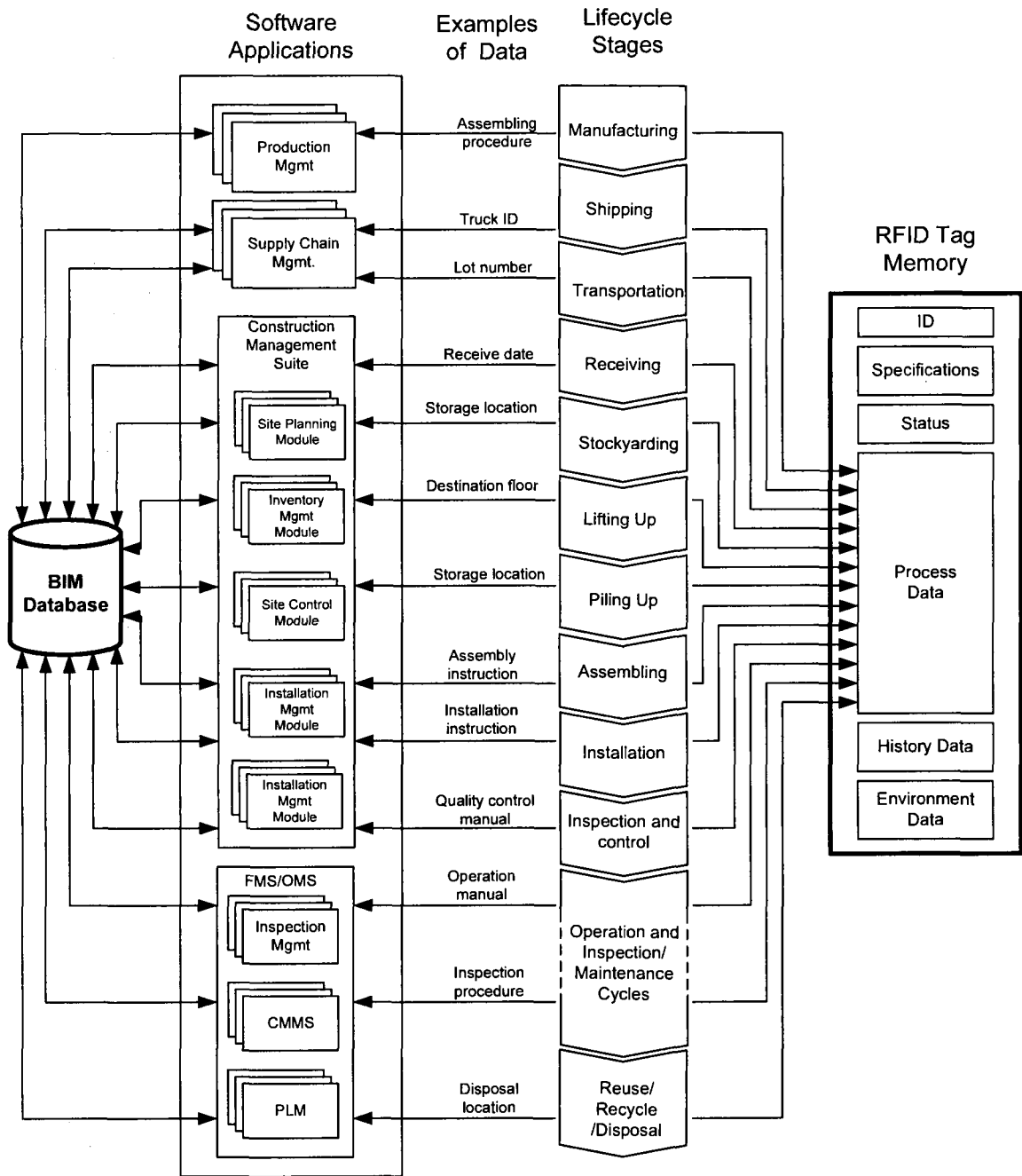

Figure 3-4 Process Data Update

3.5 BIM-TAG DATA EXCHANGE METHOD

As described in Subsection 3.2 the proposed approach suggests using the attached RFID tags as a media for storing the structured information and providing a distributed data

storage of BIM information. According to the fact that the media for storing the data is transparent to the efforts to collect, manage and share data, the data can be stored in a central database, RFID tags, or in printed documents based on a data management standard. However, having information on the RFID tags would provide anytime access to data, information redundancy, and independency from having local database or connection to a central database and more accurate and timely update of data.

Several research projects are undergoing on the subjects of lifecycle information management and identification of information exchange paths and handover methods between AECOO participants. Furthermore, as described in Subsection 2.3.5, there are projects to define data exchange methods and to identify the subset of crucial data that should be available during the lifecycle.

In order to support the implementation of our methodology there is a need for further research and standardisation efforts in BIM in the following areas: (1) IFC extensions considering the whole lifecycle data management, (2) information exchange paths between AECOO and, (3) data handover methods including the definition of crucial subset of data in every stage. It is also necessary to add RFID-related information such as the ID, specification of the tag (e.g., RF standard, range, physical properties, temperature range), and location of the attached tag on the components to existing properties in BIM database. New developments in these areas can be easily incorporated in our proposed approach.

3.6 TAG-SYSTEM DATA INTERACTION MODEL FOR STATUS TRACKING

As discussed in Subsection 3.4, the status data is used as an identifier for lifecycle stages of components. Hence, by using the status data, the subsystems that are permitted to read/modify the process data field are identified. Status data is updated by RFID scans where an RFID reader writes the new status on the tag; the status will be changed in the BIM database accordingly.

In order to demonstrate the relationship between activities timeline during the lifecycle and the related RFID-based processes that should be performed to update the status of each component, a typical work pattern for building components is used. In this pattern, the components follow the steps in the lifecycle of the constructed facility that are shown in Figure 3-5. Different players, activities and component statuses during the lifecycle are shown in the figure. The activities are described following the stage number in Figure 3-5.

- (1) **Design stage:** A unique and standard ID is assigned to each component.
- (2) **Ordering stage:** The ID of a component is communicated in the ordering stage to the manufacturer. By sending the order, the status is set to *ordered*.
- (3) **Manufacturing stage:** The manufacturer produces the ordered component, writes the ID on the appropriate tag and attaches the tag to the component. The tag is scanned in the manufacturing site and the data is communicated to the project office. Accordingly, the status of the component changes to *manufactured*.
- (4) **Shipping stage:** The component is scanned before being shipped and its status is changed to *shipped* based on the information from the carrier.

(5) **Transportation:** the component is scanned by the carrier while loading and the status is changed to *transported*.

(6) **Receiving stage:** When a component is received in the site, it is inspected and scanned, and the status of the component is changed to *received*. After this stage, based on the type of the component, it will be stored, lifted up or directly installed.

(7,8,9) **Stockyarding, lifting up, piling up stages:** In all these stages the component is scanned and the status information is automatically changed.

(10) **Assembling stage:** for the components that need to be assembled on the floor before final installation, the status is recorded after assembly process.

(11) **Installation stage:** the workers change the status of the components to *installed* after final installation. By finishing the installation, the finish date for the task associated with the component in the scheduling software would be updated. The exact information about the finish date of the task would improve the data accuracy of progress measurement.

(12) **Inspection and quality control stage:** The inspection and quality control will be done after installation, the component is scanned during the inspection and the status is changed to QC (Quality Control) passed.

(13) **Operation and maintenance stage:** the component may have several statuses in its operation stage. There might be cycles of inspection, maintenance or repair needed for the component. The general status for the components in their operation stage is in service. The components that need to be maintained and inspected regularly (e.g.,

HVAC system and other mechanical parts) are scanned by the maintenance team and the status is changed to inspected. During the maintenance stages the status of the components that are waiting to be inspected is changed to waiting for inspection.

(14) **Reuse/recycle/disposal:** based on the planned End of Life (EoF) decision by the PLM (Product Lifecycle Manager) software, the status is changed to *recycled/reused/disposed*.

The above activities timeline shows examples of RFID scans needed to change the status data on a component tag. Several other information can be read/updated on the same scan attempts (e.g., record the history data, read information from previous stage, update the process related info).

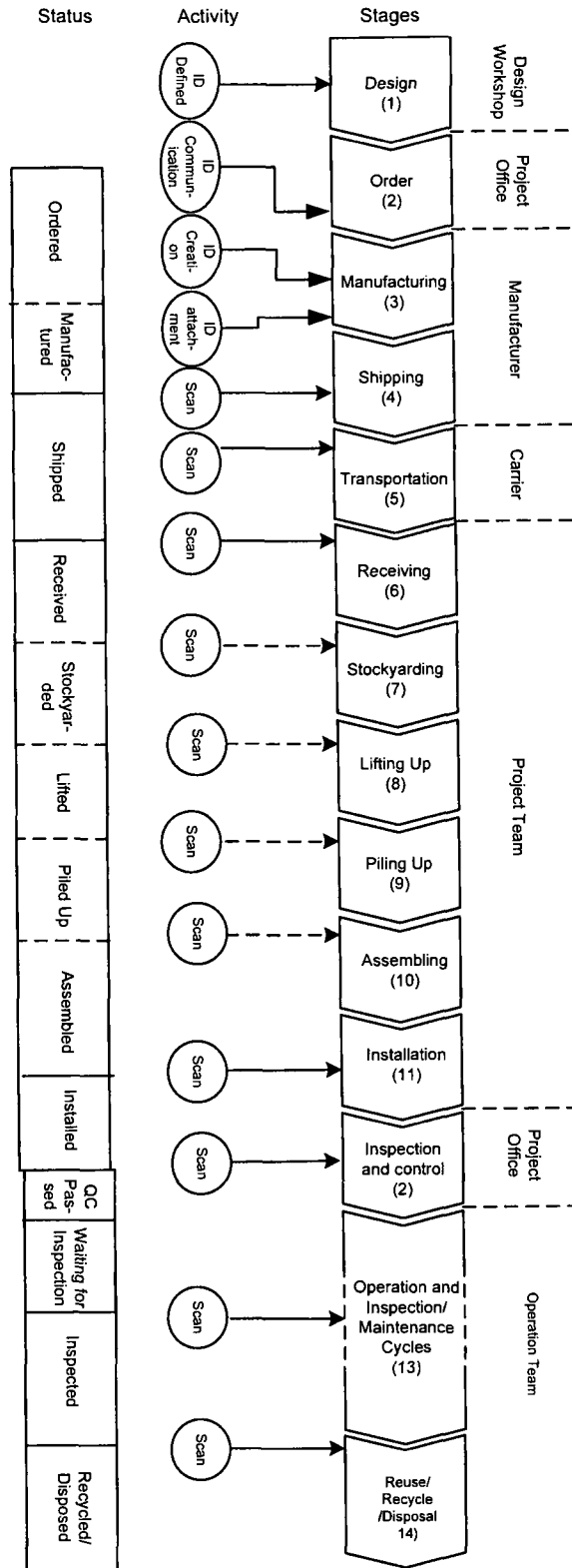

Figure 3-5 RFID-System Activity Timeline

3.7 EXAMPLES OF LIFECYCLE LOCATION MANAGEMENT USING TAG DATA

As discussed in Subsection 2.2 , by storing the information on tags, real-time data access is provided for a computer system equipped with an RFID reader. Knowing that the location of some components is needed to be tracked at different stages, which is a labour intensive activity, having the location information of the component during the lifecycle would eliminate the search time and increase efficiency.

RFID technology has been tested for locating purposes in several research projects. Field experiments show that RFID technology is not efficient in cases where accurate location is needed. There are studies undergoing to develop the methodologies and techniques to use RFID setup to locate tags based on signal strength and triangulation. These studies proposed attaching RFID tags to building components where the electromagnetic signal received from the tags can be used for locating the tags in the area. However, we are not proposing to use the RF signal received from attached RFID tags for calculating the location of components, although it might be possible. Instead, we are proposing to write the current location of the components on the attached RFID tags.

Based on our proposed approach, components should be scanned and the data on the tags should be updated before each stage or sub-stage. Consequently the location data can be updated during the same data update event. The “current location” is updated when the component is scanned by RFID reader. The location is determined by different location technologies such as GPS, USID (Ultrasound Identification), UWB (Ultra wide Band) or RFID.

GPS can be used to provide the location information in outdoor environments where the workers or trucks are equipped with GPS receivers and RFID transmitters. Moreover, the RFID tag can be coupled with GPS receiver to transmit the current location to the reader. In indoor environments, workers equipped with UWB tags can receive their location information from an UWB system and update the “current location” information on the tags while scanning them. The same approach can be applied using other RTLS (Real-time Location Systems).

The workers or inspectors can read the RFID data from distance and by retrieving the “current location” information. Having the location data, they would be able to find the component in a storage area or while they are obstructed or hidden in a facility. In this scenario, the workers need to have preloaded map or coordinate system to be able to find the components. Additionally, we propose to store routing/navigation information or maps (or part of the map) on the RFID tags. Consequently, the workers can find the object in the area without having any preloaded maps by retrieving the “current location” and the “map” or “navigation information” from the tags.

In addition to the “current location” which is useful for finding objects and could be used for supply chain visibility, other location related information can be recorded. The following location-related information could be recorded on the tags: (1) Current location (for temporary, fixed and moving components), (2) Final location when installed (for fixed components), (3) Temporary location (location of the component in the yard or storage), (4) Location of the other components, (5) Path and routing information, (6) Attached parts location, (7) Location of the subcomponents, and (8) Disposal location.

The above location information is available or would be added in BIM and can be used by different software applications, such as Enterprise Resource Planning (ERP), project management, inventory management, Computerized Maintenance Management System (CMMS), supply chain management, and Product Lifecycle Management (PLM). The location information can facilitate operations, such as locating, warehouse management, shipping and transportation, assembling and installation, supply chain visibility, site management, quality control, dismantling, repair, navigation and localization.

The location information are determined either based on the design (e.g., final location, location of attached parts, location of subcomponents) or decided during the lifecycle (e.g., temporary location, lot number, destination site) by systems, such as operation management, construction management, site management and supply chain management software. This information usually included in process-related data which is managed by different software applications and is process-specific.

As explained in Subsection 3.4, process data field contains information related to specific lifecycle stage and the data recorded on this field is changing during the lifecycle. Hence, the suggested location related information in the “process-related data” field is only present at the required stage and are managed by related software that has the ownership of process data field.

At the design stage, the ID and the “final location” of the component are created in the CAD and FM (Facilities Management) software and communicated with the manufacturer in the ordering process. While the “final location” information is written on the tag at an early stage in the lifecycle, a variety of “temporary location” information is

stored and used at various stages. Thus, in order to use relevant location information, series of read/write attempts have to be executed during the lifecycle. Figure 3-6 shows some of the possible location related information that could be stored on a tag attached to a generic fixed component. The required location information is determined based on the type of component and the processes involved in its lifecycle. The figure also shows the lifecycle stage where the location data can be used. Different colours show whether the data is stored, read or updated on the tags' memory at that specific lifecycle stage. The recommended location information to be stored on RFID tags are:

A: “*Final location*” is defined at the design stage for fixed components and recorded on the tags at manufacturing stage. This data can be used mainly in installation, operation, inspection and maintenance stages.

B: “*Subcomponents location*” is the information about the parts inside the component, e.g. mechanical parts, electronic parts, controllers and power units. This data can be used at different lifecycle stages. At manufacturing stage, it can be used by robots in the assembly line to do operations such as welding and part installation. At operation and maintenance stage, the data is useful to detach the faulty part for repair purposes and finally it could be used to dismantle the component at end-of-life stage.

C: “*Attached parts location*” is the data about how the component should be attached to its adjacent units. The data is most useful at assembling and installation stages and can be used at maintenance stage where the component is detached for repair or maintenance purposes.

D: “*Temporary storage*” is one of the main location related information that could be recorded on RFID tags and is useful at various stages. Temporary location is basically any location that the component may be stored other than its final location in the facility. The components are stored in various locations (e.g., storage, yard, shelf, floor, warehouse) during their supply chain and the prospective temporary storage can be recorded on tags to help moving the components to their temporary location.

E: “*Delivery lot information*”, can be stored and used at shipping and transportation stages and managed by supply chain management software. The data can also be used for inspection and quality control purposes.

F: “*Destination site*” is used at transportation and receiving stages where the components are transported and delivered to designated locations. There might be several destination sites during supply chain stream, where their information could be stored and read during transportation.

G: “*Disposal location*” can be recorded on the tag based on the environment factors decided by product management software. The data is used to ensure that the component is disposed in the right location

H: “*Current location*” information recorded on the long-range RFID tag can be used to locate components. According to the fact that direct line of sight is not needed to detect the tags, this information help workers/inspectors to find the component is the storage, yard or when they are obstructed in the facility. On the other hand, “current location” data for fixed objects can be used by users equipped with RFID reader to locate

themselves in the facility by reading the tags surrounding them. This data can be accessed for facility users or emergency responders as well as inspector and maintenance staff.

I and J: “*Routing information*” and “*Map*” can be used for navigational purposes. The workers, inspectors, emergency responders or general facility users can use this data to download the map and navigational information. Parts of a map can be stored on adjacent tags that are spread in the facility and the user application can get the map by extracting and combining those parts.

K: “*Location of other components*” includes the relative location of other components that do not have tags attached to them or have tags with short readability range.

L: “*Previous locations*” is the history of important previous locations of a component. These locations are managed by the Product Lifecycle Management system based on the type of the component.

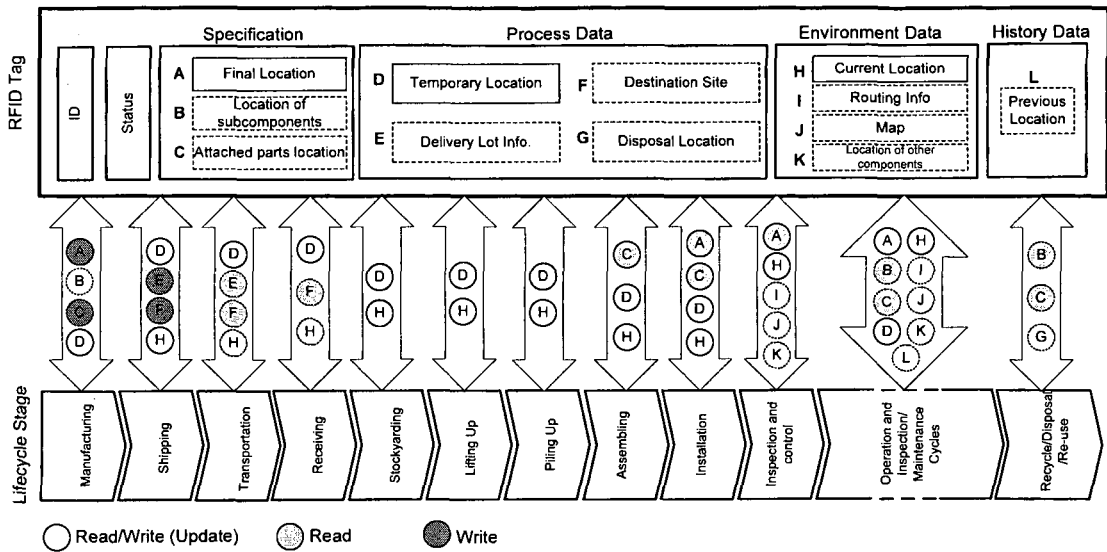

Figure 3-6 Possible Location-Related Information

3.8 SCOPE OF IMPACT AND PROSPECTIVE VALUE ADDING BENEFITS

Implementation of the proposed approach can facilitate different processes during the lifecycle and can result in various value-adding benefits by providing the needed information on the tags continuously throughout the lifecycle. The scope of impact in each process area is noted in the following.

Lifecycle Management

Having product history and process related information stored on tags attached to components provides easy access to data for various PLM software applications and eliminates the need for network connectivity to retrieve data from a central database. Furthermore, it reduces human errors since the data storage/retrieval is automated in an electronic format which minimizes the risk of data loss.

Supply Chain Management

Attaching RFID tags to components provides the ability to remotely identify and track each component individually. This feature provides more accurate supply chain visibility and improves information sharing and reduces manual paper-based record tracking.

In addition, using RFID technology reduces material handling, inspection, receiving, and loading/unloading time during supply chain and reduces human errors from labour-intensive and error-prone operations such as counting and manual data entry. It increases data accuracy and improves inventory records (Tajima 2007). Moreover, Having accurate information on the tags has the potential to improve the quality of supply chain management decisions, which have been made previously based on incomplete or less timely data (Lin et al. 2006).

Construction Management

Ability to identify and locate building components remotely and having access to real time process data in the field would facilitate various operations on construction sites. It is also expected to facilitate progress monitoring by real-time and accurate measurement of activities. Moreover, the data on the tags can provide instruction for installation and assembling.

Quality Engineering

By adding the installation and operation manuals on the tags or storing a unique link (e.g., URL or DoI) to access those instructions from a repository of manuals and guides, human errors in such activities are reduced and the process of installation and assembling

will be unified for all components regardless of the operator. It also facilitates and improves the quality of inspection and maintenance processes by storing component history and inspection guides on the component. Furthermore, available and easy-to-access information about the component status and history provides easier, faster and more accurate quality control.

End-of-Life Management

End-of-Life (EoL) management involves those options available to a product after its useful life (Parlikad et al. 2003). Thierry et al. (1998) illustrates five product recovery operations, aimed at recapturing value from EoL products that are: repair and reuse, refurbishing, remanufacturing, cannibalisation and recycling. Parts and materials that could not be recovered by any of the above five operations will be disposed in accordance with safety and environmental regulations.

The appropriate EoL method is chosen based on the information about the component materials, parts and environmental factors. The proposed approach provides the necessary information on the tag to support EoL decision making process.

Reverse Manufacturing

The operations related to the handling of waste generally involve reverse manufacturing, which transforms the EoL product/assembly into its components. Other operations include various recycling processes that recover reusable materials from the separated components based on the material composition of the components (Zhang et al. 2007). A fundamental obstacle to achieving more acceptable product recovery levels is that information associated with the product is often lost after the point of sale (Parlikad et al.

2003). Storing component information on the tags will facilitate the reverse manufacturing of components at the end of their lifecycle.

Navigational Aid

The location and routing information on the tag as discussed in Subsection 3.7 can provide navigational aid to facility users. By gathering the location and navigational information from the tags, the map or path plans are drawn without having access to a database. In addition, the user with a portable reader can locate himself based on the location of the surrounding tags.

Safety

Safety information about the components, such as safety manuals and hazardous materials information, can be stored on the tags. In addition, safety information and guidelines about the spaces (e.g., rooms, corridors, and staircases) and emergency procedures can be stored on the tags that are available in the spaces. This would provide access to important information in emergency situations where all the other information access methods are unavailable. In addition, facilitating the maintenance and repair management would directly affect the safety measures of buildings.

3.9 CHALLENGES

Although the proposed approach can be implemented using available hardware, due to high implementation and customization costs, it is not financially feasible at present. Further development in the following areas would lead to less expensive hardware solutions and more robust, industry-wide standards and low-cost supporting software applications. The challenges can be categorized under the following main topics: (1)

challenges related to adopting RFID technology, (2) challenges in extending BIM and its implementation, (3) technology adoption and social challenges, and (4) process related challenges.

(1) Challenges Related to Adopting RFID Technology

There are several challenges in adopting RFID technology that can be grouped as the following:

RF challenges: Technological challenges are related to the effects of materials such as liquids or metal on electromagnetic waves that interfere with the operation of the RFID system and shorten the readability range. Moreover, radio signals transmitted simultaneously by different tags cause collision lowering the quality of transmission and increasing the error rate.

Standards: The lack of a complete and international standard is another major issue in wide adoption of RFID systems. In addition, vendors are concerned with the high patent royalty which becomes an obstacle to the development of RFID systems (Chao et al. 2007).

Cost: Currently the cost of manufacturing and customization of tags is high. In addition, RFID systems require infrastructure to interconnect all the stakeholders to be able to communicate electronically. This infrastructure requires tremendous amount of design and implementation efforts. On the other hand, the intangible benefits of implementing RFID systems make the cost-benefit and ROI (Return on Investment) analysis more complicated.

Furthermore, barcode systems have been already implemented by many enterprises. RFID is still at developing stage; therefore, enterprises will keep two systems to operate. This will incur a double cost of maintenance of two systems for operation (Chao et al. 2007).

Security: Data Security and data privacy are considered as major concerns in adopting RFID technology. More advanced reader authentication and data protection techniques are required for implementing the proposed approach.

Ruggedness: Tags that can operate in harsh environments are needed for the construction industry. Since the tags are attached to components throughout the lifecycle, proper physical protection (e.g against temperature and material effects) is needed.

Data transfer speed: The RFID system must support high data transfer speed in order to be able to access all the information in short period of time. The low data communication rate of low frequency standards would decrease the expected efficiency of the proposed approach.

Interoperability: The wide implementation of RFID systems requires more standards to cover all types of tags and frequencies. Moreover, the need for multi-protocol tags and readers is evident for interoperability of different systems.

Power: Limited lifetime of battery-assisted tags is a challenge that should to be addressed. Hence, low power RFID systems should be further developed.

Environment: Environmental issues should be considered in manufacturing the tags by using new materials.

(2) Challenges in Extending BIM and its Implementation

The efforts for developing BIM standards are in their early stage and the available standards and implementation of BIM-based systems are not complete and thorough. As discussed in Subsections 2.3, there is an evident need for further development of BIM standards in order to extend the procedures and descriptions to the whole lifecycle of facilities. Moreover, the information flow between the stakeholders should be designed and data handover methods and lifecycle data management techniques should be further explored.

Adopting BIM standards has its own challenges and obstacles; issues such as industry acceptance, interoperability between existing software platforms, change management from conventional methods to new BIM, qualified human resources, legal considerations and initial cost to change (hardware, software, training and implementation) have to be tackled for industry-wide implementation of BIM.

(3) Technology Adoption and Social Challenges

Wide Implementation of such systems would bring resistance from companies that are using traditional methods because of needed extra efforts and training. Hence, it is important to provide strong incentives for enterprises for adoption of new technologies.

(4) Process Related Challenges

The operation and maintenance processes involved in building lifecycle should be reviewed and re-engineered considering new opportunities. The barcodes can be replaced with RFID tags where feasible, but due to technological and application difference

between barcode and RFID, the processes should be reconsidered and adopted to RFID technology. In addition, the existence of level one intelligence in the components brings about invaluable opportunities to process designers; hence profit-making procedures and subsystems should be designed and engineered.

3.10 CONCLUSIONS

The proposed methodology provides conceptual data structure and implementation approach of a futuristic vision of facilities with RFID tags attached to facilities components. The approach covered the conceptual system design and elaborated the interaction between the system components. Moreover, data capture methods from RFID tags and the data update scenarios are discussed. The proposed conceptual data structure provided a structured approach for managing the memory of RFID tags as well as the ownership of data throughout the lifecycle. In order to clarify the interrelationship between the data in a standard BIM database and the distribute memory of RFID tags, the BIM-Tag data exchange method was discussed.

To clarify more on the introduced concepts, two special cases of RFID data update and retrieval were shown. The first scenario was to identify RFID related activities needed to track the status of components, which is most useful for project progress management and component lifecycle status tracking. The second scenario was an example of lifecycle location management based on the proposed approach, which clarifies how RFID can facilitate several operations by storing location-related information.

Furthermore, the scope of impact and prospective value adding benefits of our proposed approach were discussed and several challenges to be addressed for realizing this approach were identified.

CHAPTER 4 CASE STUDIES

4.1 INTRODUCTION

Two case studies are implemented at Concordia University facilities to validate our proposed approach. In the first case study, RFID tags are used mainly to store maintenance and inspection information of fire safety equipments. In this case study the data on RFID tags are updated by inspectors to facilitate operations, such as inspection data retrieval and localization of components. The required software modules are designed and implemented. Several RFID hardware solutions are tested and the hardware solution is provided.

The second case study uses RFID technology to facilitate the process of progress monitoring and status tracking of facilities components during lifecycle. Attached RFID tags provide facility owners and project managers with accurate data related to the status of components. Additionally, the collection of data from tags is automatic and less prone to human error. Construction project schedule and progress reports can be updated by status and timing data that is gathered from attached RFID tags. Consequently, an accurate 4D model can be provided.

4.2 CASE STUDY 1: FIRE EQUIPMENT INSPECTION AND MAINTENANCE

4.2.1 BACKGROUND OF THE CASE STUDY

To reduce the probability of breakdowns, companies pay attention to planned or preventive maintenance. The success and efficiency of maintaining the facilities depends on: (1) precise and timely information on the objects to be maintained, (2) real-time

transfer of information on critical incidents, and, (3) fast access to the knowledge and means (Legner and Thiesse 2006).

Concordia Environmental Health and Safety Office (EH&S) is in charge of operation and maintenance of a big and highly dispersed environment. It covers an operational area of 75 buildings with more than 3500 fire extinguishers and 220 fire valves which need to be inspected on a regular basis. The huge amount of effort and investment need to be considered in order to operate and maintain such an environment. The conventional process of inspection, test and maintenance of the safety equipments is operational but it is not efficient and could be improved using process improvement techniques and also by using new emerging technologies.

For the purpose of fire safety equipments management at Concordia University, Concordia EH&S office provides set of requirements that are: (1) Easy identification of equipments, (2) Structured documentation, (3) Decentralized data storage, (4) Fraud prevention, (5) Paperless information management, (6) Reduce human resource and increase activities efficiency, (7) Standard compliance, and (8) Costs Reduction. Based on the assessment of the requirements and considering available resources and technologies, we have identified that management of safety equipments at Concordia University is the most suitable area to implement our proposed approach as a real-world case study.

In this case study, RFID tags are used for storing information about fire safety equipments. Amongst these equipments, fire extinguishers are chosen because of their importance and the higher frequency of their maintenance activities. In this case study, all

the required software modules have been developed and the applicability of the RFID-based system has been tested by several field experiments.

Fire extinguishers should be regularly inspected, maintained, recharged and tested based on National Fire Protection Association (NFPA) regulations and guidelines. Strict safety regulations of sensitive systems in buildings, such as fire related subsystems, force the owners to spend huge amount of money to perform inspection on a regular basis.

The safety regulations require the extinguishers to be removed from their place and be taken to a repair shop for recharging and hydrostatic testing. At the same time it is mandated to have extinguishers at all designated place. Thus, these requirements complicate the process of inventory tracking. Consequently the prospective number and the location of the extinguishers that need to be recharged/replaced are considered very valuable information for management and planning. Moreover, reduction of human errors in the management of safety related components is crucial and the processes designed for maintenance of such systems should satisfy the requirements for reliability.

The results of inspection and maintenance should be stored and be readily available for owners and insurance companies. However, this information is usually poorly structured and delivered in paper format by contractors. The results are not up-to-date and the supervision over the inspection and maintenance activities is not satisfactory.

Barcodes have been used to facilitate the maintenance and inventory tracking of the extinguishers and fire valves. The barcodes are used to quickly lookup the ID in the database without manual entry. In the currently used system at Concordia University, barcodes are used to facilitate the maintenance and inventory tracking of extinguishers

and fire valves by automatically searching their IDs in a spreadsheet without manual entry.

Case Study Target Components

Portable fire extinguishers are intended as a first line of defense to cope with fires of limited size. The selection and installation of extinguishers is independent of whether the building is equipped with automatic sprinklers, standpipe and hose, or other fixed protection equipment.

The extinguishers are available in all Concordia buildings and their inspection and maintenance are of high importance. The maintenance activities should be done regularly based on the fire safety regulations and this huge inspection and maintenance workload requires major investment and involvement of several external companies as third party contractors.

Definitions

Inspection: is a “quick check” to give reasonable assurance that a fire extinguisher is available, fully charged and operable. The value of an inspection lies in the frequency, regularity, and thoroughness with which it is conducted. The frequency will vary from hourly to monthly, based on the needs of the situation. Inspections should always be conducted when extinguishers are initially placed in service and thereafter at approximately 30-day intervals.

Maintenance: Fire extinguishers should be maintained at regular intervals (at least once a year), or when specifically indicated by an inspection. Maintenance is a “thorough check” of the extinguisher. It is intended to give maximum assurance that an extinguisher

will operate effectively and safely. It includes a thorough examination and any necessary repair, recharging or replacement. It will normally reveal the need for hydrostatic testing of an extinguisher.

4.2.2 DATA GATHERING

In order to derive the data about the existing processes in Concordia EH&S, several information gathering sessions has been held and documents has been reviewed. Prior to meeting key personnel, questionnaires were sent out to provide background on the research being undertaken, and to gather numerical data and similar information which might be difficult or impractical to gather during the interviews themselves. In all cases the key personnel had prepared answers for these questions and these proved useful documents to work from and explore further during the interviews. This method helped optimize the allotted interview time. Each interview lasted between one and two hours. Sample data gathering meeting notes and test report is presented in Appendix D.

Regulations

To protect against fire, Concordia University has different fire safety equipments and subsystems. It includes components such as sprinkler, fire valves, and fire extinguishers. As fire protection is of high safety relevance, Concordia University follows National Fire Protection Association (NFPA) Standard. It is industry proven body of standards for inspection, testing and maintenance of fire protection systems.

Several NFPA standards are being followed at Concordia University. Amongst these standards two of them are mostly used which are: NFPA25 (Standard for Inspection, Testing and Maintenance of Water-Based Fire Protection Systems) and NFPA10

(Standard for Portable Fire Extinguishers). NFPA 10 Standard for Portable Fire Extinguishers is adopted with following the scope: "The provisions of this standard apply to the selection, installation, inspection, maintenance, and testing of portable extinguishing equipment" (NFPA 2008).

4.2.3 STANDARD PROCEDURE AND GUIDELINES

Table 4-1 is the NFPA timetable for any inspection, maintenance, recharging, and testing of portable fire extinguishers. All of the following information and paragraph numbers can be found in the 2002 edition of the NFPA-10 (NFPA 2008).

Standard Procedure for Inspection

Periodic inspection of fire extinguishers shall include a check of at least the following items (NFPA-10-6.2.2):

- (1) Location in designated place.
- (2) No obstructions to access or visibility.
- (3) Operating instructions on nameplate legible and facing outward.
- (4) Safety seals and tamper indicators not broken or missing.
- (5) Fullness determined by weighing or "hefting."
- (6) Examinations for obvious physical damage, corrosion, leakage, or clogged nozzle.
- (7) Pressure gauge reading or indicator in the operable range or position.
- (8) Condition of tires, wheels, carriage, hose, and nozzle checked (for wheel units).
- (9) Label in place.

Maintenance procedures shall include a thorough examination of the basic elements of a fire extinguisher (NFPA-10-6.3.2):

- (1) Mechanical parts of all fire extinguishers.
- (2) Extinguishing agent of cartridge- or cylinder-operated dry chemical stored chemical, stored pressure, loaded stream, and pump tank fire extinguishers.
- (3) Expelling means of all fire extinguishers.

Table 4-1 NFPA-10 Timetable

Extinguisher Type	Inspection*	Maintenance **	Recharging ***	Hydrostatic Testing*
Dry Chemical (Stored pressure)	30 Days (6.2.1)	1 Year (6.3.1)	Empty and internally inspect @ 6 Years (6.3.3 & 6.4.3.4)	12 years (Table 7.2)
Carbon Dioxide	30 Days (6.2.1)	1 Year (6.3.1.2, 6.3.1)	5 Years (6.4.1.1, 6.4.3.9, & 6.4.5.1)	5 years (Table 7.2)
Water (Stored pressure)	30 Days (6.2.1)	1 Year (6.3.1)	1 Year (6.4.2.1 & 6.4.3.10)	5 years (Table 7.2)
Dry Chemical (Stainless Steel)	30 Days (6.2.1)	1 Year (6.3.1)	5 Years (6.4.3.4)	5 years (Table 7.2)
Dry Chemical (Cartridge)	30 Days (6.2.1)	1 Year (6.3.1)	Empty and internally inspect @ 6 Years (6.3.3, 6.4.3.4)	12 years (Table 7.2)
Wet Chemical	30 Days (6.2.1)	1 Year (6.3.1)	5 Years (6.4.3.11)	5 years (Table 7.2)
AFFF (Liquid charge type)	30 Days (6.2.1)	1 Year (6.3.1)	3 Years (6.4.2.3)	5 years (Table 7.2)
FFFP (Liquid charge type)	30 Days (6.2.1)	1 Year (6.3.1)	3 Years (6.4.2.3)	5 years (Table 7.2)
Dry Powder	30 Days (6.2.1)	1 Year (6.3.1)	Empty and internally inspect @ 6 Years (6.3.3, 6.4.3.4)	12 years (Table 7.2)
Halogenated (Halon)	30 Days (6.2.1)	1 Year (6.3.1)	Empty and internally inspect @ 6 Years (6.3.3, 6.4.3.4)	12 years (Table 7.2)
<p>* The time periods indicated in the above table are to be viewed as the maximum period for each activity.</p> <p>** For maintenance procedure see NFPA-10 and Annex I of NFPA-10.</p> <p>*** Recharging is also required to take place after every use and if the need is identified during maintenance or inspection.</p>				

4.2.4 EXISTING PROCEDURES

The service technicians receive their daily work assignment on paper. The work assignments consist of a list of fire extinguishers to be inspected and the respective maintenance orders. First, they have to find and access each extinguisher, which might be difficult to get at. In order to facilitate locating the fire equipments, inspectors are provided with paper-based floor plans with fire equipment signs (Figure 4-1). Finding equipments are time consuming process since the paper maps are not easy to read and not regularly updated.

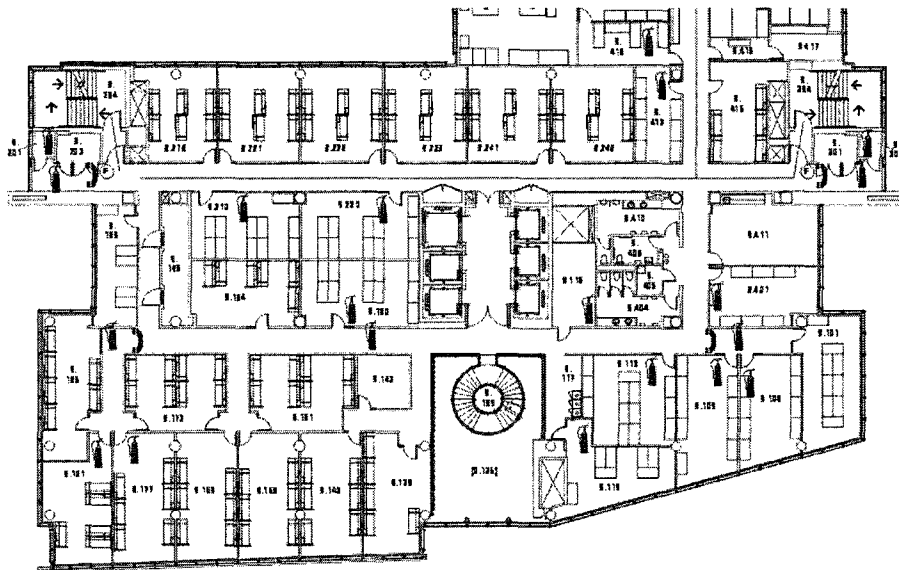

Figure 4-1 Part of Floor Plan with Fire Equipments Signs

Before using tablet PC for manual inspection data entry, the technicians handwrote lengthy maintenance reports after inspection as proof that they had actually done the inspection. Later, they handed in completed maintenance reports to the office clerks, who in turn entered the report into the back-end system and forwarded it for archiving. In the case of defects, an overhaul had to be planned. This paper-based process proved to be

error prone, and manual data entry is time-consuming. With the paper-based archive, obtaining detailed information on actual maintenance history was a tedious process. Sample paper based maintenance report is available in Appendix B.

Because maintenance reports were often poorly structured or information was missing, many additional inquiries arose. Concordia hires contractors to perform most inspections and pays them on the basis of the number of extinguishers they inspect. In the past, Concordia EH&S office had to control the work that has been done by the contractor to verify the quality of the service.

The newer system has been adopted by the external contractor. In the new system the handheld devices are used to scan bar-codes that are attached to both safety equipments and also the location of the items (fire extinguishers cage or fixtures).

The access database and off-the-shelf software was used for managing data. The newer process involved manual entry of data for all the information except for entering the ID of the extinguisher and location ID which are being done with barcode scanning. Recently, the system was improved by adding predefined barcodes for the “defect type” and “status” entry in the database. The new enhancement aimed to eliminate the manual data entry and data unification for some part of database. The status barcodes are printed on a piece of paper that is being carried on by the inspector. The inspector scans the appropriate status barcode based on the actual inspection results (Figure 4-2).

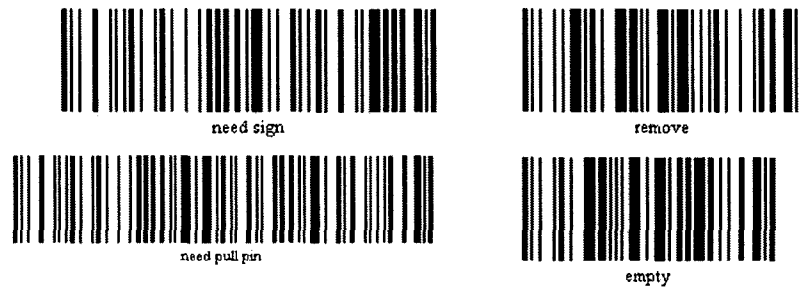

Figure 4-2 Sample Barcode for Data Entry

4.2.5 PROPOSED SYSTEM

In our prototype system, crucial information is stored on tags attached to the extinguishers. This would provide the information about the history and the condition of the extinguishers for inspectors and maintenance/ repair personnel without having access to any central database. Thus, it provides data redundancy and eliminates the rework due to none-up-to-date data.

Two different types of tags have been tested and used in the prototype system: Active tags with 8 or 32 KB of memory and standard passive tags with 96 bits of memory. The active tags are long range but the passive tags have the readability range of few inches for a typical handheld reader. The selected tags are designed to be attached to the components throughout their lifecycle. Hence, they are rugged and have large number of allowed read/write cycles. Moreover, the selected tags are designed to work well near liquids and metals.

Short write distance for tags would guaranty that the inspector did the inspection and maintenance activity in close proximity of valves and, that he lifted and displaced the extinguishers in order to update the data. Furthermore, the software will not allow the

inspector to finish the task unless the record is updated on the tag. This provides fraud prevention for maintenance activities and increases the reliability.

Conceptual System Design

Fire Safety Equipment Maintenance Management System is initially composed of following components:

- (1) **RFID Tags:** Passive or active tags attached to fire extinguishers that contains information about the extinguisher.
- (2) **RFID Reader:** PCMCIA (Personal Computer Memory Card International Association) portable reader module compatible with standard passive tags or proprietary active tags that is being held by Concordia EH&S personnel.
- (3) **Handheld Device:** PDAs equipped with PCMCIA slot that host the RFID reader and the software.
- (4) **Middleware Software:** the developed software for communicating with RFID tags and backend Database.
- (5) **Database:** data storage that contains all the data about history of inspection and maintenance activities as well as information about the equipments and work orders.

Figure 4-3 shows the schematic view of proposed system. The data is saved on RFID tags and a local database on the handheld computer and local data would be synchronized with the main database via wireless network connectivity or offline.

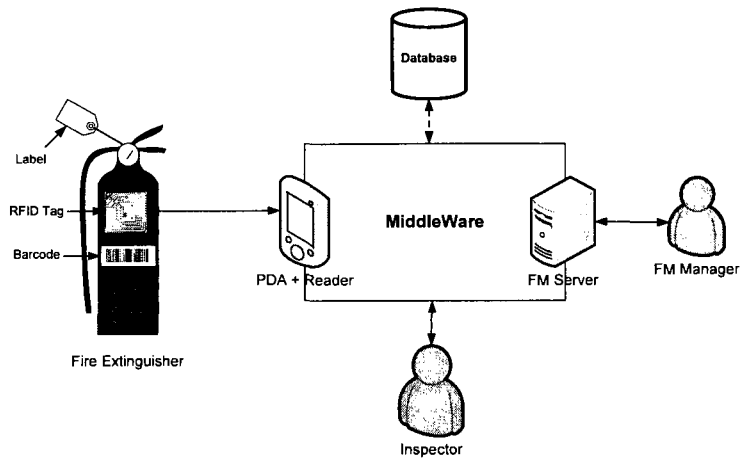

Figure 4-3 Conceptual System Design for Case Study

Based on the requirements introduced by Concordia EH&S Office, the second RFID tag that contains information about the location of extinguishers is added to the system after the development of prototype system and concept proofing phase.

RFID Tag Data Structure

The designed system is intended to work for different types of components and different tag types. In other words the design aims to be expandable and support multi-tag environment. Different RFID tags provide various data capacities, most of ISO 18000-6 compatible tags that operates on ultra-high frequency have minimum of 96 bits of data capacity. 96 bits refer to the ID structure know as EPC.

However, 96 bits ID has been designed to identify enormous collection of the objects (2^{96} potential unique IDs) the Id range provided is beyond our needs. Since more data than ID is desired to be stored on the tags, available 96 bits should be re-structured and design to store the required information.

Based on our design some information about the component other than its unique ID is needed to be written on the tag. The data on the tag is subset of data in the main database. The required data fields should carefully selected based on the requirements, in some cases the data in the original FM database should be “abbreviated” to smaller set of binaries and be stored on the tag.

Selection of crucial data to be stored on the extinguisher tags are based on the NFPA guidelines and result of the meetings with field inspectors and EH&S staff. The most important criteria for selecting the data field are the applicability of data. The data in the tag should have the usage and meaning when considered solely regardless of the database data (which is more complete). The main purpose of adding data as well as the ID on the tags is to provide the capability to perform information gathering/maintenance/repair activities without having access to data in database.

The memory of the tags has been segmented and contains to the following information: (1) ID, (2) Specification (e.g., manufacturing date), (3) Status, (4) Maintenance data (e.g., condition and defective part), (5) History (e.g., last inspection date) and, (6) Environment data (e.g., location). Table 4-2 shows the data structure for the passive tags attached to fire extinguishers.

Due to the limited memory of passive tags, the above information is squeezed to binary codes and stored on the tags. The software translates BIM data related to components to codes using lookup tables and store codes in designated memory spaces on the tags. The main data is stored in a MySQL database as well as ifcXML representation of BIM.

Table 4-2 Standard Tag Data Structure

ID (32 bits)	Type (9 bits)		
	Model (5 bits)		
	Serial (18 bits)		
DATA (64 bits)	Specifications	Manufacturing Date (14 bits)	
	Status	Status (1 bit)	
	Maintenance Data (14 bits)	Condition (7 bits)	Obstructed
			Pressure High
			Pressure Low
			Loose
			Dusted
			Rusted
			Damaged
		Defective Part (7 bits)	Missing Pin
			Missing Rivet
			Missing Label
	Environment Data	Location (21 bit)	Missing Sign
Neck Bended			
Plugged Hose			
History	Last Inspection Date (14 bits)	Seal Broken	
		Building (7 bits)	
		Floor (4 bits)	
		Room (10 bits)	

Software Design

The conceptual diagram in Figure 4-4 illustrates the design of the RFID based system. It shows the interaction between the hardware and software components as well as the interaction of the end-user with the system by the means of the GUI (Graphical User Interface). Furthermore, the diagram lists the functionalities available to the end-user which involve: reading from the tag and the database, performing the inspection, updating the database, and writing to the tag. The middleware controls the reader to start scanning and saves the received tags in a container. The IDs received will be processed and converted from the MySQL database conversion table to significant information that

will be outputted to the user. After performing the inspection, the new information will be written on the tag, and the database field will be updated.

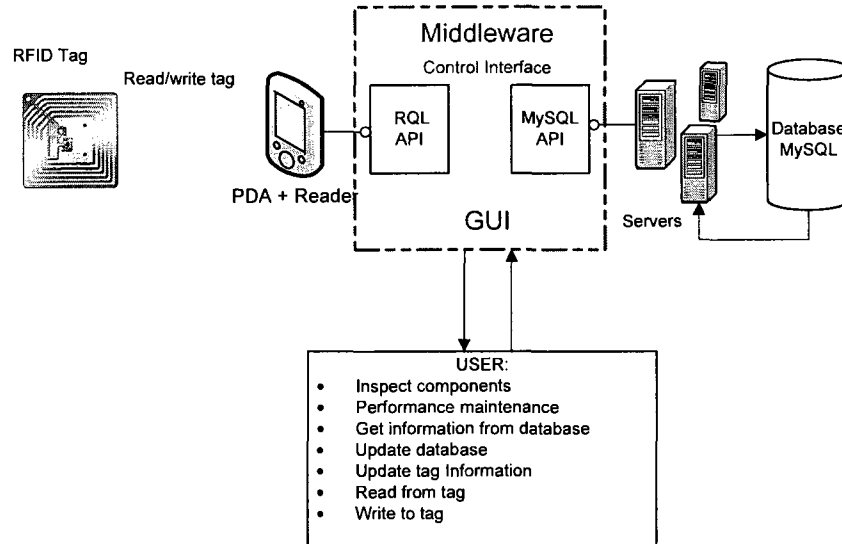

Figure 4-4 Design of RFID Based Inspection/Maintenance Management System

Prototype Software Flowchart

The user logs in to the system in order to proceed with the software. The login procedure involves entering the user name (code) and the password. The EH&S users would be assigned a RFID badge that has their user code. The inspector can login to system by scanning his/her RFID badge and entering the password. The system can support fingerprint authentication in conjunction with ID scan in future improvement. This would guaranty that the inspector is logging to the system and could be used as a fraud prevention feature. Furthermore, the login time and information is recorded in the database for the record.

After authentication, the user would have access to different operations based on his rights that is defined in the database. The major operations developed for prototype system are: (1) new maintenance task, and (2) view data. “View Data” is an option to retrieve information from the database about specific extinguisher by entering its ID or scanning its tag. Reporting features can be added under “View Data” as software extensions.

By selecting “New Task”, EH&S worker can load the assigned “job”. “Job” or “work order” is the list of inspection/maintenance activities that is planned for the inspector by supervisor. The inspector can manually add extinguisher IDs that are not in the list but are needed to be added to the task list. Software would provide visualization of the extinguishers in the “job” list on the floor plans to aid the inspector locate the extinguishers on the floor.

The software also provides navigation aid for the inspector to locate the extinguishers in the building using active tags. The software has pre-loaded floor plans as a visualization layer. By surveying the area to detect the tags, the sensed tags are shown on the floor plan based on their location information. Using the long range tags allows inspectors to visually find the surrounding components on the floor plan and decreases the time needed to locate them. Figure 4-5 shows a sample snapshot of the screen, where the locations of sensed components are shown with red stars on the floor plan and it helps the user to visually identify the components on the plan.

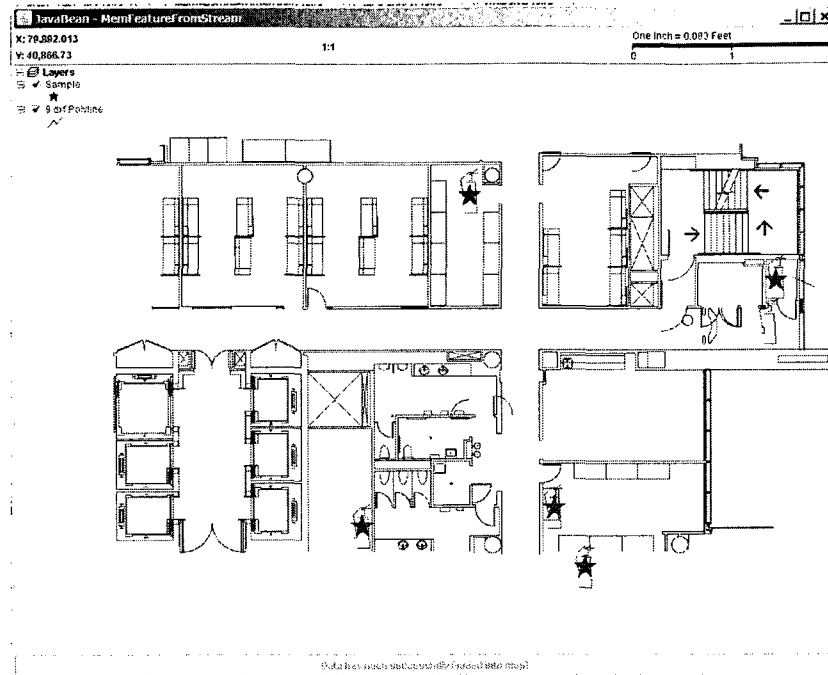

Figure 4-5 Snapshot of Location Management Software

After finding the extinguisher, the inspector starts the task by scanning the extinguisher tag. It might be possible that more than one tag is being read while scanning, in this case, the system shows the information of the sensed tag and the user is required to choose the appropriate tag to proceed using an indexing system. The software shows the location data that is available on the tag to the inspector and asks for the confirmation. The data that is recorded on the tag is shown and it helps the inspector to quickly review the history of inspection and also the previous maintenance result and information about the type and possible defects of the extinguisher.

Before performing the actual inspection, the software automatically generates alerts for the inspector based on the data that is available on the extinguisher tag. The alerts are designed to warn the inspector about the required maintenance/repair/replacement procedure based on the regulation. Alerts are generated based on the type of the

extinguisher, its date of manufacturing, type of defect, the condition of extinguisher and the last inspection date. All of this information is on the tag and the standard requirements are coded on the middleware. The software compares the information against the standard requirement and generates alerts accordingly. This easy-to-implement alert system minimizes human errors that exit in manual operation.

The “wizard” contains the checklist of inspection and maintenance activities based on the type of extinguishers. It can include the standard procedures as a reference for less experienced EH&S workers. The inspector performs the tasks and complete easy-to-fill forms of the wizard (in the format of checkboxes or drop down menus). This data entry step is comparatively faster and more accurate than paper based system. Furthermore, the data will be saved in a structured fashion and do not need re-entry to the system.

The inceptor views the result of inspection/maintenance activity and confirms. The middleware updates the data on the tag and then saves the data on local database. The task is considered to be completed only after the successful data update of RFID tag and database. Figure 4-6 shows the developed software flowchart. Sample GUI interface of developed software is available in Appendix F.

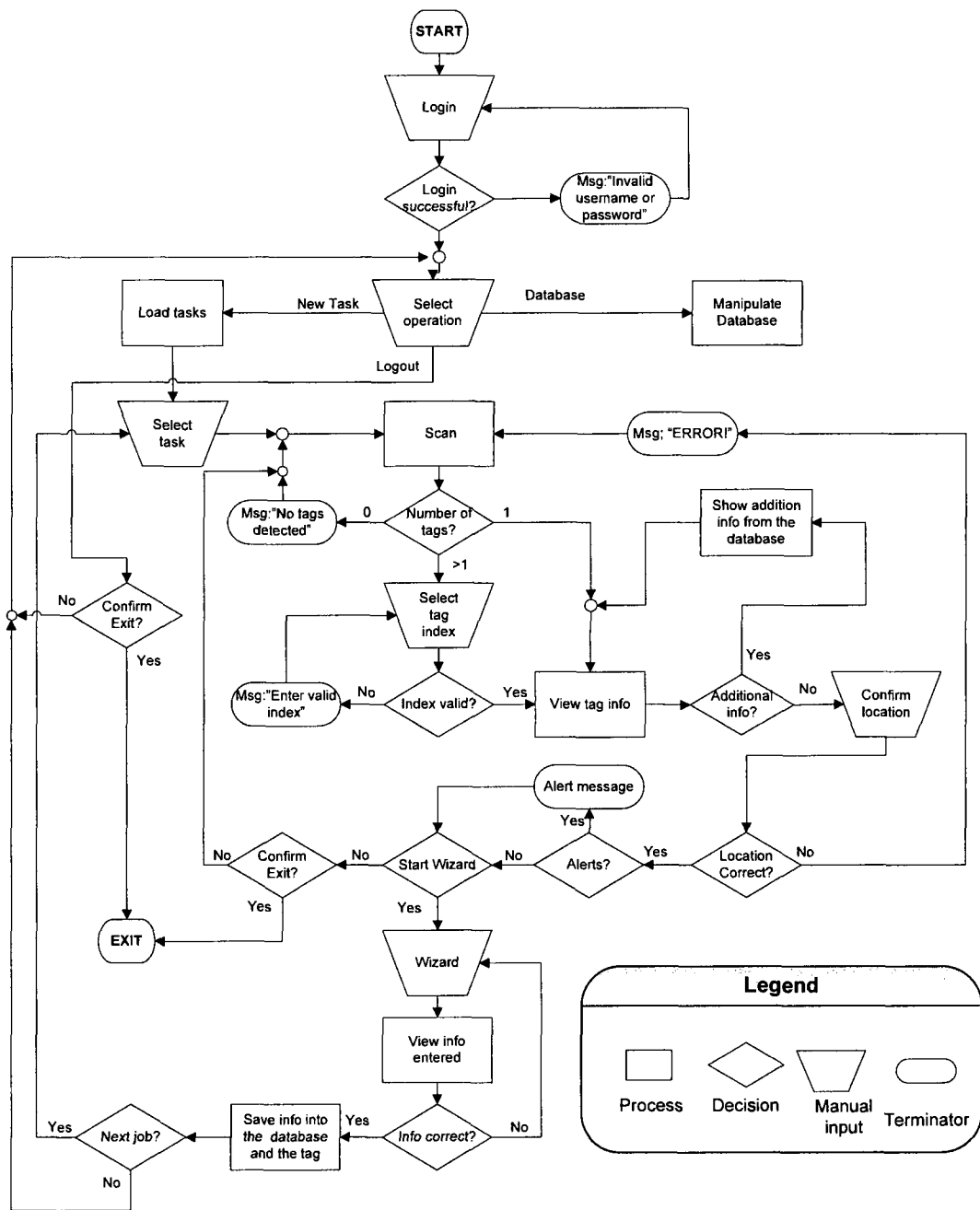

Figure 4-6 Software Flowchart

Improved Flowchart for Pilot Implementation

After development of prototype software, the software has been tested and has been demonstrated for Concordia University EH&S Office and fire inspection subcontractor.

In the improvement phase, result of tests and proposition by Concordia EH&S team about the functionality of the software has taken to account and the new flowchart has been developed for the pilot implementation software.

The pilot case study system uses two categories of tags: (1) Location tag (L.T.) that is attached to the location of extinguishers and, (2) Item tag (I.T.) that is attached to extinguishers.

The inventory of extinguishers is being tracked by the location of the items. Following the guidelines and standards there should not be any location without the required safety equipments. This requirement would enforce the Concordia EH&S office to maintain the existence of a functional extinguisher on designated locations. There is no obligation by to assign a specific extinguisher in a location. Although there is no need to keep the same extinguisher in the same location, the type of the extinguisher at that location needs to be checked, meaning the type of the extinguisher is considered as one of the location properties.

Figure 4-7 and Figure 4-8 show the flowcharts of the pilot system. The major processes in software flow (identified by number in flowcharts) are as follow:

- (1) The inspector logs in to the system by entering username/password or scanning his ID card.
- (2) After authentication and authorization he selects the type of operation. One of the three major operations could be chosen.
 - **View data:** for retrieval of stored information on the tags (L.T. or I.T.) or the data base information such as the history of the objects

- **New Maintenance:** to start new inspection/maintenance activity
- **New Repair:** this operation is for assisting the repair shop processes and can be completed in the future if needed.

View Data

- (3) There are two methods for retrieving information.
 - Scanning the I.T./L.T.
 - Entering the ID or the description of the item/location
- (4) The scanned tag or entered ID, is either L.T. or I.T. (could be easily differentiated by identifier bit), Base on the type of the tag, stored information on the tag and also database records for that item is shown.
- (5) The inspector has the option to view the history of the item/location from the database.

New maintenance

- (6) For the new maintenance activity there are three options available for the inspector:
- (7) **Load job:** the task list (the list of fire extinguishers that are planned to be inspected by inspector through operation management system) can be loaded. After choosing this option the list is loaded from the database and the inspector would do the job as planned. After loading the lists the related maps with the target extinguishers are shown in the software.
- (8) **Scan area:** the inspector have the option to scan the area to detect the location tags. The tags that are sensed by the RFID reader in that area are shown in the related map.

(9) **Enter location info:** the inspector chooses this option if he knows which building or floor he wants to inspect. By selecting the desired location from the drop down menus, he selects the location and the related map with the sign of extinguishers is shown in the software.

After deciding on the inspection target (the extinguisher that is going to be inspected) the inspector would find the item using the map.

(10) Inspector starts the inspection/maintenance activity.

(11) The location tag (L.T.) is scanned first and the information on the tag is shown. The inspector has the option to edit the data on the location tag but since the location tag information are fixed data, the option to edit is not considered are major step.

(12) The inspector then scans the item tag. (I.T.)

(13) Based on the previous information recorded on the tag, related alerts are shown. The sample alerts are: “Hydrostatic test needed”, “Recharging needed”, “The extinguisher is obsolete” and, “Extinguisher type is invalid”.

The alerts are automatically generated by software based on the information on the items and also the time and date on the PC. It would eliminate the chance for human error.

(14) The wizard is the major part of the software; it includes a user friendly checklist to log the inspection/maintenance results. The status of the extinguisher and also the name of the defected part can be entered in the system using user friendly interface. The inspector can also get the instruction for inspecting different types of extinguishers if needed.

(15), (16) After completing the actual inspection and entering the information about the possible defective part or condition of the extinguisher. The software shows the data to be written in the database and tag and request for confirmation.

(17) If the information is correct the data is written on the Item tag and stored in the local database.

The location information to be written on the item tag (I.T) comes from the L.T. that is previously scanned. Also the current date is taken from the PC and is automatically added to the Item tag.

(18) The inspector can go to the next extinguisher to inspect or terminate the process.

Hardware Test

Several hardware-related tests have been conducted in order to identify appropriate RFID tags and readers for the case studies. The test has been designed to identify suitable set of tags and readers and antennas with required readability range ruggedness and noise protection for each scenario and component. Summary of a sample hardware test report is available in Appendix E.

Case Study 1 Implementation Summary

This case study has been done in a pilot scale in EV building of Concordia University where active and passive tags were attached to 9th floor fire valves and extinguishers. The technological feasibility of the system has been tested in a real working environment. The full implementation of the proposed system is being proposed to the EH&S office for all the buildings at Concordia University (Appendix C).

Login View Database

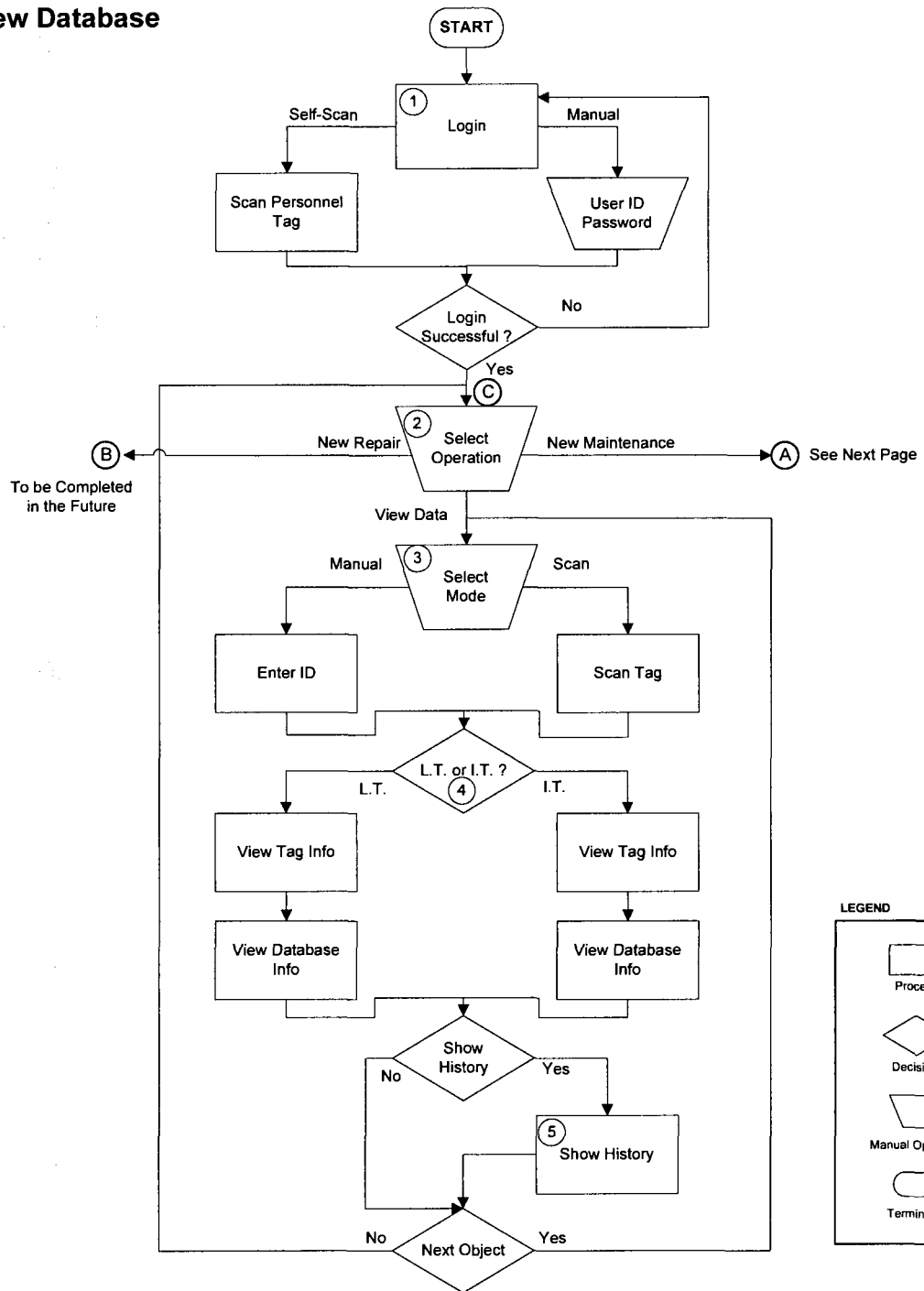

LEGEND

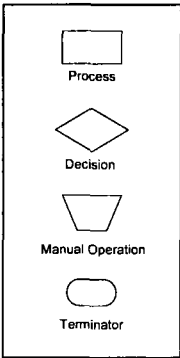

Figure 4-7 Login and View Data flowchart

New Maintenance

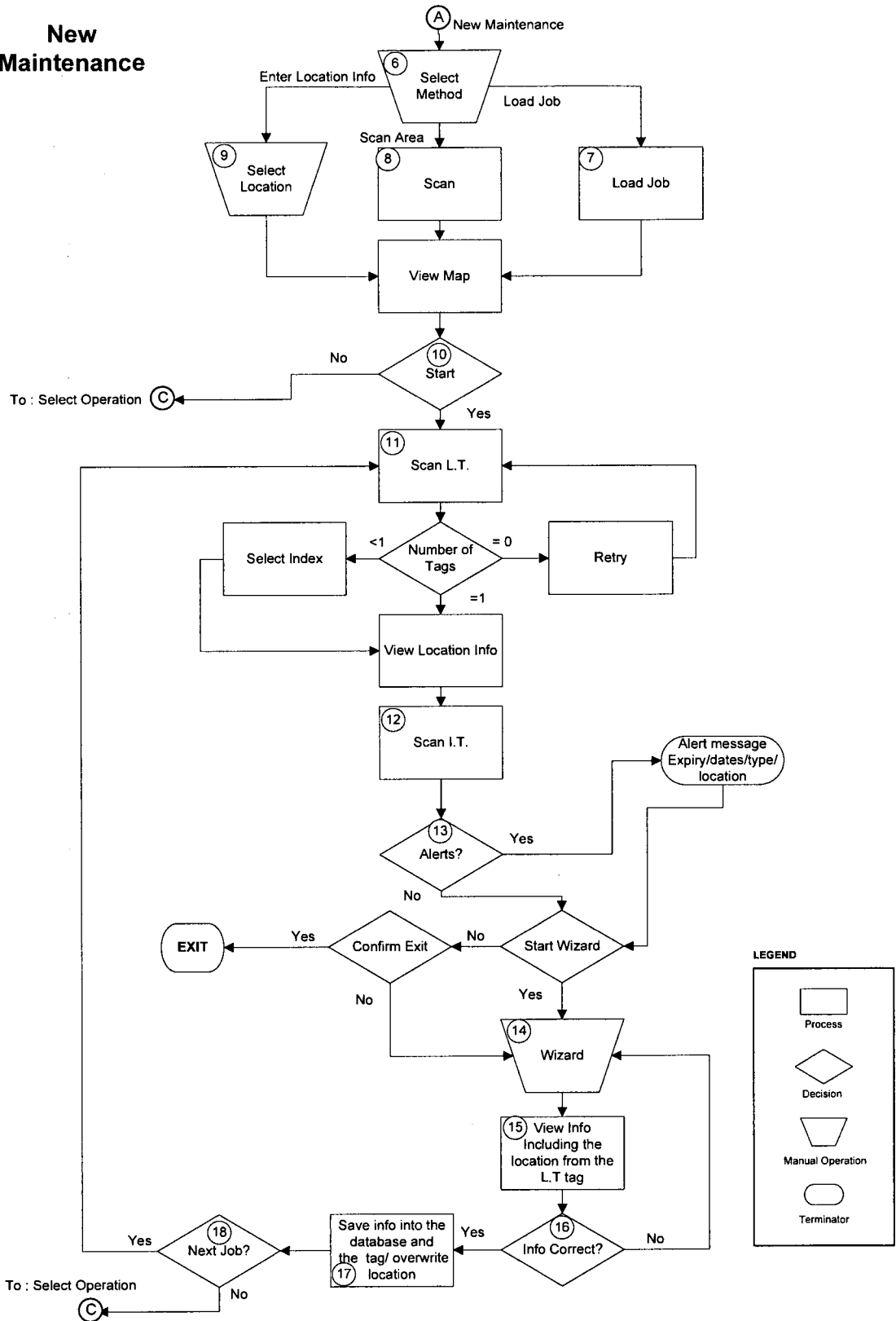

Figure 4-8 New Inspection/Maintenance Flowchart

4.3 CASE STUDY 2: PROGRESS MANAGEMENT AND 4D VISUALIZATION

This case study is designed to facilitate the process of progress monitoring of construction projects and to provide visualisation aid for component status tracking. The result of implementing the case study is accurate progress measurement data resulting in accurate 4D model and 3D visualization of building component based on their status.

The prototype system is composed of six subsystems: (1) the database that store the data extracted from the BIM, which will be updated by RFID reads and other software updates (e.g., inspection data), (2) the 3D modeling software that stores the data in IFCxml format, (3) the scheduling software, (4) the 4D simulation software, (5) the FM software, and (6) the RFID reader interfaces. The communications between the subsystems are based on standard protocols providing scalability and interoperability. The software components and the relationship between them are shown in Figure 4-9. The structure proposed for the database includes fields such as: ID, design code, status, type, ordering date, manufacturing date, shipping date, receiving date, stockyarding date, piling-up date, lifting-up date, assembling date, installation date, quality control date, task start, task finish, last inspection date and next inspection date. The 4D simulation software obtains the geometrical information from the 3D software and the timing and status information from the database to produce different real-time views of the facility using a predefined colouring scheme. These views help project managers and the FM team to better visualize the status of the facility.

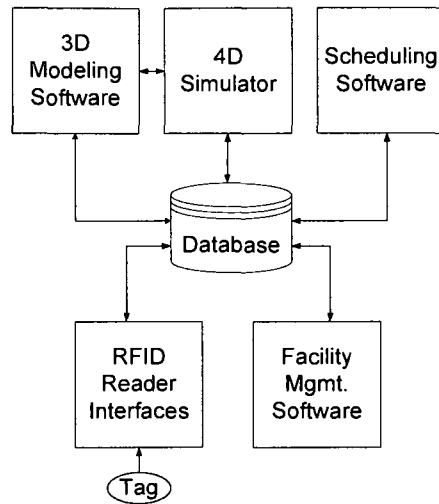

Figure 4-9 System Structure

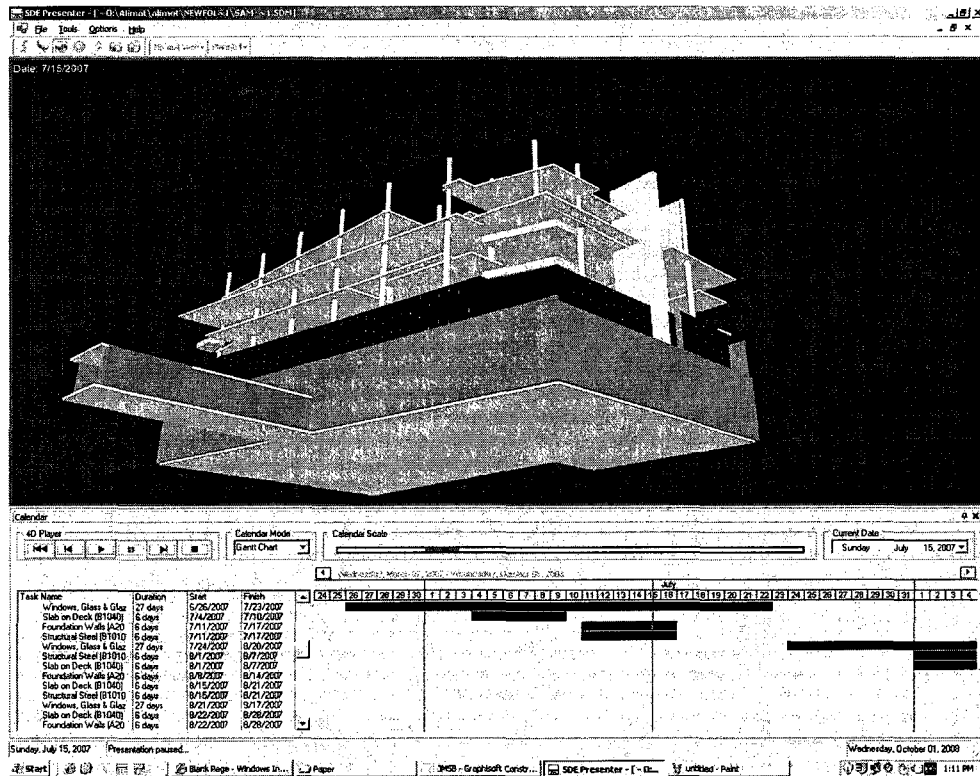

Figure 4-10 4D Simulation of the JMSB Project

In this study, we focused on the progress monitoring and lifecycle management of the HVAC components in the new building of John Molson School of Business (JMSB) at Concordia University. The construction project is a high-rise building located in downtown Montreal. Graphisoft suite is used for 4D modelling and scheduling (Graphisoft 2008). The main software in the suit, Constructor, is a complete package for building construction models and linking them with scheduling applications. The other used software packages are Control for scheduling and 5D Presenter for progress simulation. Microsoft Project is also used for schedule management and progress monitoring. The RFID reader interface is used for entering data into the database. Various Identec Solution (Identec 2008) active RFID tags are used. The tags operate in UHF frequency and have 8 or 32 KB of memory.

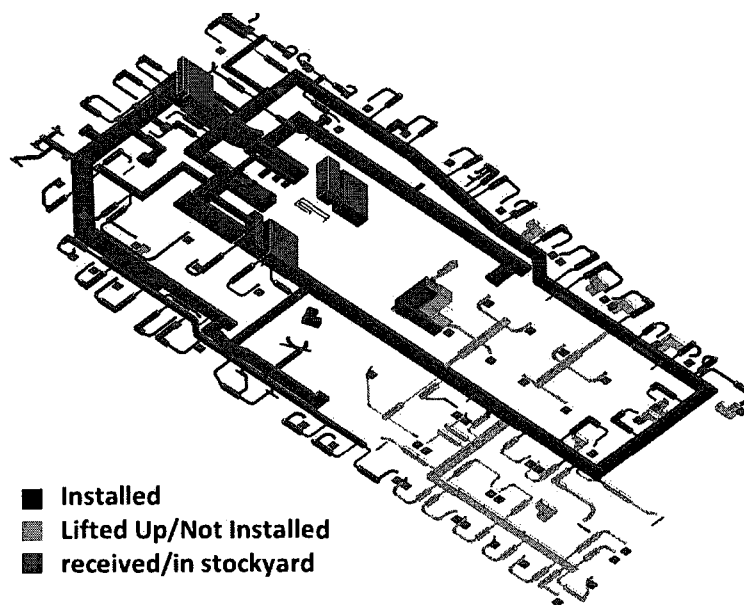

Figure 4-11 HVAC 3D Drawing of One Floor of the JMSB Building: Construction Phase

Figure 4-10 shows the 4D simulation of the JMSB project, the anticipated task durations are based on the initial planned schedule, and the actual durations for finished tasks are

updated using the database. Figure 4-11 and Figure 4-12 shows sample snapshots of 4D visualization of the HVAC system on the 14th floor of the building. Figure 4-11 shows the status of the components during the construction phase. The components that are installed are shown in black. The components that are lifted up but not yet installed are shown in red. The components that are in the stockyard and have not been lifted up are shown in grey. Figure 4-12 shows the status visualization during the operation phase. The component in green is waiting for inspection and the component in dark brown needs to be repaired based on the database status. The exact number and types of the needed tags and the precise location of attaching the tags should be designed and tested for different components in our future research.

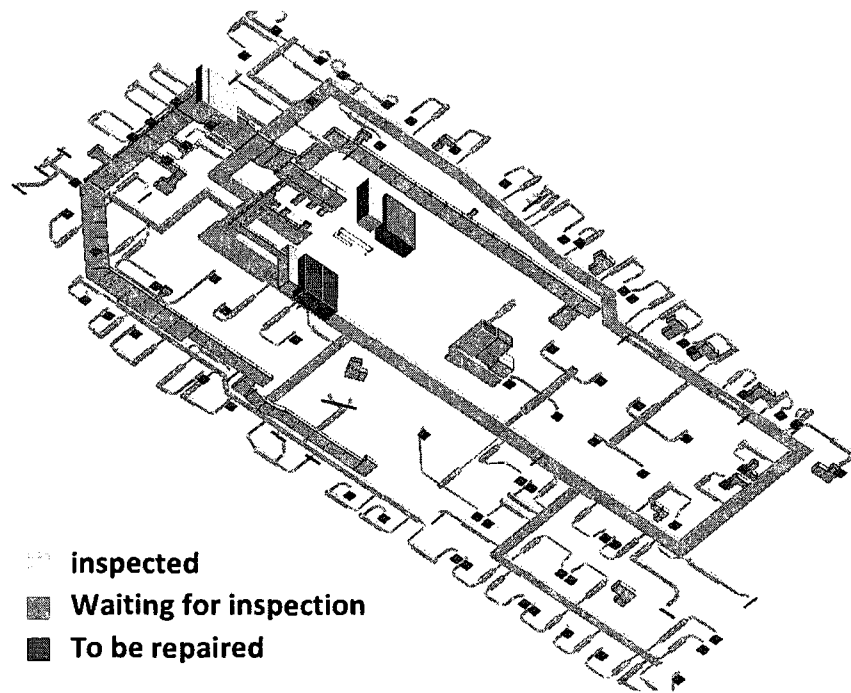

Figure 4-12 HVAC 3D Drawing of One Floor of the JMSB Building: Maintenance Phase

4.4 SUMMARY

Two case studies showed the applicability of the proposed approach. They covered different types of components and facilitated different processes. As efforts to develop full BIM are still evolving, the full implementation of the first case study should fill the missing gaps by extending the BIM for representing safety equipments using ifcXML format. It is concluded that further implementation of BIM standards and tools are necessary for future improvements.

Although available RFID hardware solutions were able to store the required data and provided the system with acceptable data readability range and accuracy, the price of active tags is still considerably high. In order to benefit from RFID based solutions, a detailed cost-benefit analysis should be performed and the target components should be carefully selected. Using the proposed systems for sensitive components or components with high maintenance rate could to be feasible when considering all tangible and intangible benefits.

CHAPTER 5 CONCLUSIONS AND FUTURE WORK

5.1 SUMMARY OF RESEARCH

The research proposed permanently attaching RFID tags to facility components where the memory of the tags is populated with accumulated lifecycle information of the components that is taken from a standard BIM database. This information is used to enhance different processes throughout the lifecycle. In addition, this research suggested storing other types of BIM information on RFID tags which is not necessarily related to the components themselves. Consequently, having BIM data chunks stored on tags allows data access for different players who do not have real-time access to a central database. In this research, a conceptual RFID-based system structure and data storage/retrieval designs were elaborated and the data exchange method between RFID tags and BIM through different applications during the lifecycle is discussed.

Our research provides a framework and data management techniques to support a futuristic vision of facilities with RFID tags attached their components. Furthermore, the research elaborated on the prospective value-adding benefits and scope of impact of using such distributed data storage.

Although the case studies showed the technical feasibility of our proposed framework using available hardware, several challenges identified in this research should be addressed to make the vision practical and financially feasible.

5.2 RESEARCH CONTRIBUTIONS AND CONCLUSIONS

The framework introduced in this research proposes using a standard information system, i.e. BIM, for lifecycle data management combined with RFID technology. This would

address the need for “integration of the accessed data with the broader information systems used across organizations” (Ergen et al. 2007b), which has been identified as a major challenge in previous related research. The research promotes using industry-wide, standard and interoperable information to serve as data source for RFID tags. Additionally, our approach suggests storing the crucial subset of data in a distributed data memory of RFID tags that are attached to facilities components and spread in the facility.

The proposed approach covers broad range of techniques to manage components’ lifecycle data as well as extending the idea of RFID-attached component to other types of engineered components within a constructed facility (i.e., made-to-order and off-the-shelf components). While other research projects mostly focus on a certain type of components or a specific lifecycle stage, our proposed approach provides conceptual data structure, data management and interaction design that can be applied for all components during the lifecycle. We also propose to include broader data types on the RFID tags that are attached to building components and are spread in a building. The case studies showed the applicability of our proposed approach and validated the usability of the various methods identified in this research.

The research contributions can be summarized as follows: (1) Proposing the concept of distributed facilities components lifecycle BIM data on permanently attached RFID tags; (2) System interaction design for the proposed concept; (3) Data structure architecture for components’ tags; (4) Data exchange model between RFID tags and BIM throughout the lifecycle; (5) Location management and status tracking solution based on the proposed approach; and (6) Case studies to verify the applicability of the proposed approach.

5.3 ROADMAP FOR SMART BUILDING LIFECYCLE MANAGEMENT

Hannus et al. (2003) provided "Construction ICT Roadmap" with the objective of developing a vision of ICT (Information and Communication Technology) support in the construction sector and to form a strategy for future research and development towards the vision.

According to the roadmap, the vision for future ICT in construction is defined as: "Construction sector is driven by total product life performance and supported by knowledge-intensive and model based ICT enabling holistic support and decision making throughout the various business processes and the whole product lifecycle by all stakeholders". Their Proposed Strategic Roadmap focuses on new and emerging ICTs. However, it also indicates opportunities to the industry to take up existing technologies. The report describes high level the strategies, for realising the main trends and provide easily understood illustrations of the roadmap as simple diagrams in order to enable easy dialog between stakeholders.

Twelve different visions have been identified for top level roadmap. The roadmap shows strategies toward achieving the visions. The report provides the "subroadmap" diagrams which discuss suggested steps toward different visions into different time spans, and shows alternative routes how to proceed depending on specific priorities of the stakeholders. The tentative time to exploitation of results is given as an indicator of the time frame:

- **Take-up:** Adopt, deploy & demonstrate mainly existing technologies (0-2 years).
- **Development:** Clearly defined RTD to achieve exploitable results (3-5 years).

- **Research:** Prototyping is required to find the way forward (6-10 years).
- **Emerging:** Exploring RTD needs and opportunities for potential solutions (11-20 years).

Our proposed research, ultimately suggests adding levels of intelligence to building components during their lifecycle. The vision is called *smart building lifecycle management*. It involves a broad range of ICT technologies and areas. The roadmap toward this vision is the combination of steps that were introduced in "subroadmaps" under several different visions in "Construction ICT Roadmap". The most related trends are: digital site, ambient access, smart building, total lifecycle support, and flexible interoperability where the proposed research is a logical extension of them

Error! Reference source not found. shows the identified steps and paths toward our vision from related "subroadmaps" in Construction ICT Roadmap. Hence, it is the combined version of related roadmap diagrams. The figure provides the overall view about the logical paths toward *smart building lifecycle management* and the areas that requires further development for realization of our proposed approach. The diagrams in ICT Roadmap meant to provide a high level view, the "big picture", on the directions for future RTD (research and technological development) in construction. Hence, it should be noted that the illustrations are simplified and in reality many RTD issues are interlinked in a very complex way. These interrelations cannot be captured by simple diagrams. Details about the steps and paths can be found in Hannus et al. (2003) and Hannus (2007).

5.4 LIMITATIONS AND FUTURE WORK

The following steps are necessary for fully realizing the proposed approach: (1) identifying most suitable building components for tagging based on cost-benefit analysis considering long-term value adding benefits, (2) re-engineering existing construction and maintenance processes for the selected components, (3) investigating product-specific and detailed tag structure for the selected components, (4) extracting important process data to be stored on the tags for each lifecycle stage of selected components, (5) technology selection and field testing for available RFID hardware, and (6) investigating new information to be added to BIM related to RFID.

REFERENCES

Aimglobal (2008). What is RFID, Retrieved October 2008, from:

<http://www.aimglobal.org/technologies/rfid/what_is_rfid.asp>.

Akinci B., Patton M. and Ergen E. (2002). Utilizing radio frequency identification on precast concrete components—supplier’s perspective, *Proceedings of ISARC '02*, IAARC, Washington, DC, 381–386.

Associated General Contractors Guide (2006). AGC Contractors’ Guide to BIM, from:

<<http://www.agcnebuilders.com/documents/BIMGuide.pdf>>.

Chao C., Yang J., and Jen W. (2007). Determining technology trends and forecasts of RFID by a historical review and bibliometric analysis from 1991 to 2005, *Technovation*, 27(5), 268-279.

Chin S., Yoon S., Choi C. and Cho C. (2008). RFID + 4D CAD for progress management of structural steel works in high-rise buildings, *Journal of Computing in Civil Engineering*, 22(2), 74-89.

Chin S., Yoon S., Kim Y.S., and Kwon S.W. (2006). An Application Model of RFID Technology on Progress Measurement and Management of Construction Works, *ISARC2006*, 779-783.

Chin S., Yoon S. W., Kim Y. S., Ryu J., Choi C. and Cho C. Y. (2005). Realtime 4D CAD + RFID for project progress management, *Proceedings of Construction Research Congress*, San Diego, California, USA.

- Collier E., and Fischer M. (1996). Visual-based scheduling: 4D modeling on the San Mateo County Health Center, *Proceedings of Computing in Civil Engineering*, J. Vanegas and P. Chinowsky, eds., ASCE, Reston, Va., 800–805.
- Construction Industry Institute (CII) (1987). Project Control for Construction, Publication No. 6-5, 1987.
- Construction Industry Institute (CII) (1995). 3D Link, Research Summery, 106-1.
- Dittmer K. (2004). Blue Force Tracking—A Subset of Combat Identification, *Military Review*, from:
<<http://usacac.leavenworth.army.mil/CAC/milreview/download/English/SepOct04/ditt.pdf>>.
- Domdouzis K., Kumar B. and Anumba C. (2007). Radio-frequency identification (RFID) applications: A brief introduction, *Advanced Engineering Informatics*, 21(4), 350-355.
- East W. E. and Brodt W. (2007). BIM for Construction Handover, *Journal of Building Information Modeling*, 28-35.
- East W. E. (2008). Construction operations building information exchange (COBIE). Retrieved October 2008, from: <<http://www.wbdg.org/resources/cobie.php>>.
- EPCglobal (2008). EPCglobal tag data standards version 1.4, EPCglobal, from:
<http://www.epcglobalinc.org/standards/tds/tds_1_4-standard-20080611.pdf>.
- EPoSS (2008). Internet of things in 2020 - A roadmap for the future. European Technology Platform on Smart Systems Integration.

- Ergen E., Akinci B., East B. and Kirby J. (2007a). Tracking components and maintenance history within a facility utilizing radio frequency identification technology, *Journal of Computing in Civil Engineering*, 21(1), 11-20.
- Ergen E., Akinci B. and Sacks R. (2003). Formalization and automation of effective tracking and locating of precast components in a storage yard, *Proceedings 9th EuropIA International Conference*, EIA9: E-Activities and Intelligent Support in Design and the Built Environment, Europia, Istanbul, 31-37.
- Ergen E., Akinci B. and Sacks R. (2007b). Life-cycle data management of engineered-to-order components using radio frequency identification, *Advanced Engineering Informatics*, 21(4), 356-366.
- Ergen E., Akinci B. and Sacks R. (2007c). Tracking and locating components in a precast storage yard utilizing radio frequency identification technology and GPS, *Automation in Construction*, 16(3), 354-367.
- FIATECH (2008). Report Documents Materials and Asset Tracking Using RFID, Retrieved October 2008, from: <<http://www.fiatech.org/news/10-08-04.html>>.
- Fischer M., and Kam C. (2002). PM4D final report, Technical Rep.No. 143, Center for Integrated Facility Engineering, Stanford University, Stanford, California.
- Fleming Q.W. and Koppleman J.M. (1996). Earned value project management, Project Management Institute (PMI), Upper Darby, Pa., USA.
- Furlani K.M., Pfeffer L. E. and Stone W.C. (2000). Automated part tracking on the construction job site, *Proceedings of the Robotics 2000— ASCE Conference on Robotics for Challenging Environments*, Albuquerque, N.M.

- Furlani K.M. and Pfeffer L.E. (2000). Automated tracking of structural steel members at the construction site, *Proceedings ISARC '00*, IAARC, Taipei, 1201-1206.
- Furlani K.M. and Stone W.C. (1999). Architecture for discrete construction component tracking, *Proceedings ISARC '99*, IAARC, Madrid, 289-294.
- Gallaher M.P., O'Connor A.C., Dettbarn J.L. and Gilday L.T. (2004). Cost analysis of inadequate interoperability in the US capital facilities industry, NIST Publication GCR 04-867, from: <<http://www.bfrl.nist.gov/oea/publications/gcrs/04867.pdf>>.
- Ghanem A.G. and AbdelRazig Y. A. (2006). A framework for real-time construction project progress tracking, *Earth and Space 2006*, (188)112.
- Graphisoft R&D zrt. (2008). from: <<http://www.vicosoftware.com/>>.
- Goldstein H. (2001). 4D: Science fiction or virtually reality?, from: <<http://www.construction.com/NewsCenter/it/features/01-20010416.asp>>.
- Goodrum, P. M., McLaren, M. A. and Durfee, A. (2006). The application of active radio frequency identification technology for tool tracking on construction job sites, *Automation in Construction*, 15(3), 292-302.
- Griffis F. H., et al. (2001). 3D CAD and FIAPP: Three-dimensional computer models and the fully integrated and automated project process, Research summary, 152-1, Construction Industry Institute (CII).
- Hammad A. and Motamedi A. (2007). Framework for lifecycle status tracking and visualization of constructed facility components, *Proceedings of the 7th International Conference on Construction Applications of Virtual Reality*, October 23-24, Penn State University, University Park, PA.

Harrington R.F. (1964). Theory of Loaded Scatterers, *Proceedings of the IEE*, 111 (4), 617–623.

Hannus M. (2007). FIATECH capital projects technology roadmap, ECTP FA PICT, from: <http://www.fiatech.org/pdfs/projects/fiatech_ectp_mapping.pdf>.

Hannus M., Blasco M., Bourdeau M., Bohms M., Cooper G., Garas F., Hassan T., Kazi A. S., Leinonen J., Rezgui Y., Soubra S. and Zarli A. (2003). Construction ICT roadmap. IST-2001-37278, from: <http://cic.vtt.fi/projects/roadcon/docs/roadcon_d52.pdf>.

Harrison M. and Parlikad A. K. (2006). Lifecycle ID and lifecycle data management, AUTO-ID Labs, AEROID-CAM-005, from: <<http://www.autoidlabs.org/single-view/dir/article/6/264/page.html>>.

Harrison M. (2007). Guidelines for lifecycle ID & data management, AEROID-CAM-014, from: <http://www.aero-id.org/research_reports/AEROID-CAM-014-Lifecycle.pdf>.

Hu W., He X., and Kang J. H. (2005). From 3D to 4D visualization in building construction, Computing in Civil Engineering 2005 International Conference, Cancun, Mexico.

Identec (2008). Identec Solutions, from: <<http://www.identecsolutions.com/>>.

IDM 2007, Information Delivery Manual, from: <<http://www.iai.no/idm/index.html>>.

IFC Model (2008). Industrial Foundation Classes, International Alliance for Interoperability, from: <http://www.iai-international.org/iai_international>.

- Ifc-mBomb (2004). Ifc Model Based Operation and Maintenance of Buildings, Retrieved October 2008, from: <http://cig.bre.co.uk/iai_uk/iai_projects/ifc-mbomb/>.
- Isikdag U., Aouad G., Underwood J. and Wu S. (2007). Building information models: A review on storage and exchange mechanisms, Bringing ITC Knowledge to Work, 24th W78 Conference, Maribor.
- Isikdag U., Underwood J. and Aouad, G. (2008 accepted). An investigation into the applicability of building information models in geospatial environment in support of site selection and fire response management processes, *Advanced Engineering Informatics*, In Press, Corrected Proof.
- ITU (2005). ITU Internet Reports 2005: The Internet of Things, International Telecommunication Union (ITU), Geneva.
- Jaselskis E. J., Anderson M. R., Jahren C. T., Rodriguez Y. and Njos S. (1995). Radio-frequency identification applications in construction industry, *Journal of Construction Engineering and Management*, 121(2), 189-196.
- Jaselskis E. J. and El-Misalami T. (2003). Implementing radio frequency identification in the construction process, *Journal of Construction Engineering and Management*, 129(6), 680-688.
- Kamat V. R., and Martinez J. C. (2001). Visualizing Simulated Construction Operations in 3D, *Journal of Computing in Civil Engineering*, 15(4), 329-337.
- Kang J. K., Anderson S. D., and Clayton M. J. (2007). Empirical Study on the Merit of Web-Based 4D Visualization in Collaborative Construction Planning and

Scheduling, *Journal of Construction Engineering and Management*, 133(6), 447-461.

Khemlani L. (2004). The IFC building model: A look under the hood, AECbytes,

Retrieved October 2008, from:

<<http://www.aecbytes.com/feature/2004/IFCmodel.html>>.

King R.J. (1978). Microwave homodyne systems, *IEE 1978*, Peter Peregrinus Ltd.

Kiziltas S. and Akinci B. (2005). The Need for Prompt Schedule Update by Utilizing Reality Capture Technologies: A Case Study, Construction Research Congress 2005: Broadening Perspectives.

Kiziltas S., Akinci B., Ergen E. and Tang P. (2008). Technological assessment and process implications of field data capture technologies for construction and facility/infrastructure management, *ITcon*, Special Issue Sensors in Construction and Infrastructure Management, (13), 134-154.

Landt J. (2005). The history of RFID, *IEEE Potentials*, 24 (4), 8–11.

Legner C. and Thiesse F. (2006). RFID-Based Facility Maintenance at Frankfurt Airport. *IEEE Pervasive Computing*, 5(1), 34-39.

Lin D., Barton R., Bi H. and Freimer M. (2006). Challenges in RFID enabled supply chain management, *Quality Progress*, 39 (11), 23-28.

McCarthy J.F., Nguyen D.H., Rashid A.M. and Soroczak S.(2003). Proactive Displays & The Experience UbiComp Project, *Adjunct Proceedings of the Fifth International Conference on Ubiquitous Computing (UbiComp 2003)*, Seattle, 78-81.

- McFarlane D., Sarma S., Chirn J.L., Wong C.Y., and Ashton K. (2003). Auto id systems and intelligent manufacturing control, *Engineering Applications of Artificial Intelligence*, 16 (4), 365–376.
- Meye G., Främling K., and Holmström J. (2009). Intelligent Products: A survey, *Computers in Industry*, 60(3), 137-148.
- Moradpour S. (2005). Solving the RFID Cost-Benefit Equation, *RFID Product News*, from: <http://www.rfidproductnews.com/issues/2005.01/feature/cost.php>.
- NBIMS (2005). Charter for the National Building Information Model (BIM) Standard, NIBS, from: http://www.facilityinformationcouncil.org/bim/pdfs/NBIMS_Charter.pdf.
- NBIMS (2007a). National Building Information Modelling Standard Part-1: Overview, Principles and Methodologies, US National Institute of Building Sciences Facilities Information Council, BIM Committee, from: <http://www.facilityinformationcouncil.org/bim/publications.php>.
- NBIMS (2007b). National Building Information Model Standard, Version 1, Part 1, from: http://www.facilityinformationcouncil.org/bim/pdfs/NBIMsv1_ConsolidatedAppendixReferences_11Mar07_1.pdf.
- NFPA (2008). National Fire Protection Association, From: <http://www.nfpa.org/>
- Parlikad A. K., McFarlane D., Fleisch E. and Gross S. (2003). The role of product identity in end-of-life decision making, CAM-AUTOID-WH-017, Auto-ID Centre.
- Peyret F. and Tasky R. (2002). Asphalt quality parameters traceability using electronic tags and GPS, *Proceedings of ISARC '02*, IAARC, Washington, DC, 155-160.

- Post N. M. (2002). Movie of job that defies description is worth more than a million words, ENR, McGraw-Hill, 248(13).
- Rischmoller L., Fisher M., Fox R., and Alarcon L. (2001). 4D planning and scheduling (4D-PS): Grounding construction IT research in industry practice, *Construction Information Technology, Proceedings of CIB W78 International Conference—IT in Construction in Africa*, Mpumalanga, South Africa.
- SAP (2005). SAP Mobile asset management at Fraport AG, from:
<www.sap.com/solutions/mobilebusiness>.
- Scansource.com (2008). RFID frequencies, from:
<http://www.scansource.com/europe/upload/RFID_Frequencies.pdf>.
- Schell D. (2001). Oil refinery uses RFID to eliminate rework and reduce data entry by 70% , *Business Solutions*, January 2001, Retrieved October 2008, from:
<[http://www. businesssolutionsmag.com](http://www.businesssolutionsmag.com)>.
- Simons K. L., Thornberry H. L., and Wickard D. A. (1988). Simulation system for construction planning and scheduling, *Joint ASME/IEEE Power Generation Conference*, Philadelphia.
- Song J. (2005). Tracking the location of materials on construction projects. Submitted in Partial Fulfilment of the Requirements for the Degree of Doctor of Philosophy, Faculty of the Graduate School of the University of Texas at Austin.
- Song J., Haas C.T., Caldas C. and Liapi K. (2005). Locating materials on construction site using proximity techniques, *Construction Research Congress*, April 5-7, San Diego, US, 552-557.

- Song J., Haas C. T., Caldas C., Ergen E. and Akinici B. (2006a). Automating the task of tracking the delivery and receipt of fabricated pipe spools in industrial projects, *Automation in Construction*, 15(2), 166-177.
- Song J., Haas C. T. and Caldas C. H. (2006b). Tracking the location of materials on construction job sites, *Journal of Construction Engineering and Management*, 132(9), 911-918.
- Stephens J., Leonard D., Groom C. and Nisbet N. (2005). Life-cycle data for buildings: Opportunities for the IFC model based operation and maintenance (Ifc-mBomb), IAI UK Ltd.
- Stockman H. (1948). Communication by Means of Reflected Power, *Proceedings of the IRE*, 1196-1204.
- Thierry M.C., Salomon M., van Nunen J. and Van Wassenhove L. (1998). Strategic issues in product recovery management, *California Management Review*, 37 (2), 114-135.
- Thomas H.R., and Mathews C.T.(1996). An Analysis of the Methods for Measuring Construction Productivity, CII Source Document 13.
- Tajima M. (2007). Strategic value of RFID in supply chain management, *Journal of Purchasing and Supply Management*, 13(4), 261-273.
- Umetani T., Arai T., Mae Y., Inoue K. and Maeda J. (2006). Construction automation based on parts and packets unification, *Automation in Construction*, 15(6), 777-784.

- Vanlande R., Nicolle C. and Cruz C. (2008). IFC and building lifecycle management, *Automation in Construction*, 18(1), 70-78.
- Williams M. (1996). Graphical simulation for project planning: 4Dplanner, *Computing in Civil Engineering*, J. Vanegas and P.Chinowsky, eds., ASCE, Reston, Va., 404-409.
- Wong C. Y., McFarlane D., Ahmad Zaharudin A. and Agarwal V. (2002). The intelligent product driven supply chain, 2002 IEEE International Conference on Systems, Man and Cybernetics, Yasmine Hammamet, Tunisia.
- Yabuki N. and Oyama T. (2007). Application of radio frequency identification technology for management of light weight temporary facility members, ASCE Workshop on Computing in Civil Engineering, Pittsburgh, 697-704.
- Yabuki N., Shimada Y. and Tomita K. (2002). An on-site inspection support system using radio frequency identification tags and personal digital assistants, *Proceedings of the 2002 CIB w78 Conference*, Aarhus School of Architecture.
- Yabuki N., Yamashita T., Shimada Y. and Sakata T. (2004). Application of RFID tags to an on-site inspection support system for large dams, *Proceedings of the third Civil Engineering Conference in the Asian Region*, Seoul, Korea, 397-400.
- Yagi J., Arai E. and Arai T. (2005). Parts and packets unification radio frequency identification (RFID) application for construction, *Automation in Construction*, 14(4), 477-490.
- Yoon S., Chin S., Kim Y. and Kwon, S. (2006). An application model of RFID technology on progress measurement and management of construction works, 23rd

International Symposium on Automation and Robotics in Construction (ISARC),
Tokyo, Japan.

Zhang H. C., Li J., Shrivastava P., Whitley A. and Merchant, M. E. (2004). A web-based system for reverse manufacturing and product environmental impact assessment considering end-of-life, *CIRP Annals -Manufacturing Technology*, 53(1), 5-8.

APPENDICES

APPENDIX A - LIST OF RELATED PUBLICATIONS

- Motamedi A. and Hammad A. (2009). Lifecycle Management of Facilities Components Using Radio Frequency Identification and Building Information Model, Next Generation Construction IT, *Journal of IT in Construction* (Paper Accepted).
- Motamedi A. and Hammad A. (2009). RFID-Assisted Lifecycle Management of Building Components Using BIM Data, *26th International Symposium on Automation and Robotics in Construction (ISARC)*, Austin, Texas, U.S. - June 24-27 (Paper Accepted).
- Motamedi A. and Hammad A. (2009). Lifecycle Management of Facilities Components Using Radio Frequency Identification and Building Information Model, *Fifth international conference on construction in the 21th century, CITC-V*, Istanbul, Turkey, 20-22 May 2009 (Paper Accepted).
- Hammad A. and Motamedi A. (2007). Framework for Lifecycle Status Tracking and Visualization of Constructed Facility Components, *Proceedings of the 7th International Conference on Construction Applications of Virtual Reality*, October 23-24, Penn State University, University Park, PA.

APPENDIX B - SAMPLE MAINTENANCE REPORT



PYROSECUR
PREVENTION INCENDIE

PYROSECUR Prévention Incendie
207, rue Lévesque
Lachenaie, Québec
J6W 5P9
Tel: (450)492-0074
Mtl: (514)992-PYRO
Alléaire au Canada
sans frais 1-877-992-PYRO
Fax: (450)492-6196

COMMANDE D'ATELIER

DATE
20 Dec 2001

FACTURE A:	LIVRAISON:
Concordia	17-64-10

Noire no de commande	Termes	Votre no de commande	Reference	Vendeur	Prochaine inspection
E344	net	61000-1	RL-014959	01	

Pièce	Description	Com	Livr	B/C	P/Unitaire	Montant
	ver. de. ext. milieu	42	42	-		
	ver. de. loges	3	3	-		
	hydro test base	3	3	-		
	recharge 10" ABC	4	4	-		
	gauge G175	1	1	-		
	pull pins	2	2	-		
	recharge 25 gal SUP	2	2	-		
	wall hook wallie	2	2	-		
	recharge + test 10" (C)	2	2	-		
	applic. de base	2	2	-		
	plast. de pulv (10")	2	2	-		

No. TPS: R122483623

No. TVQ: 1008612028

Les marchandises décrites ci-dessus demeurent la propriété de PYROSECUR jusqu'au paiement final et sont affectées d'un droit de 2% sur ventes, taxes, frais d'administration (1¢ par article) et par année par facture.

[Signature]
Signature de Client

[Signature]
Nom en lettres mouillées

[Signature]
PYROSECUR

Sous-tot.	
TPS @ 7.0%	
TVQ @ 7.5%	
Total	

APPENDIX C - PROPOSAL FOR RFID-AIDED INSPECTION SYSTEM FOR CONCORDIA UNIVERSITY FIRE AND SAFETY EQUIPMENTS

Proposed draft prepared by Amin Hammad* and Ali Motamedi**

*Associate Professor, Concordia Institute for Information Systems Engineering

**Graduate Student, Concordia Institute for Information Systems Engineering

Abstract

The proposed software aims to aid the Concordia University facilities management department in the area of inspection/maintenance of fire and safety equipments. The proposed system provides improved processes and also uses Radio Frequency Identification technology to identify objects and store information.

Scope

The proposed tool is designed for managing the maintenance and inspection operation of the fire extinguishers and fire hoses as well as fire valves in the first phase.

The design of the system including the data structure, middleware and the backend database is expandable so the scope could be further expanded to other equipments such as first aid kits and mechanical parts of the building.

Also the software could be further developed to include operations other than maintenance and inspection such as repair management or logistics.

Opportunity Statement

The strategic goal of the group is to improve the current processes within the area of facilities management and also continue research and contribution to this field and become a reference to institutions on the innovative uses of RFID technology.

Aside from the research, the group is trying to implement and test the applications of new ideas and concepts through field projects. Particularly in the case of the new concept of improving inspection and maintenance processes with the help of RFID. We believe that a collaborative effort could be established between our group and the Concordia University Facilities Management (FM) to run a test project in that effect. This project would require the installation of RFID technology to track and document inspection processes which provides:

- Reduced inspection process time/cost
- Real-time information about components
- Electronic database system instead of manual documentation procedure of inspection reports
- Structured information storage/retrieval
- Support for the operators with less expertise
- Redundant data
- Fraud prevention
- Real time monitoring bed for management level supervision

Design Criteria

Two major design factors are modularity and using standard protocols. Modularity would facilitate further expansion and customization with less effort and following standards eliminates vendor dependability and provides long term cost reduction

Required Features

Fundamental Requirements

- Central information logging
 - Inventory
 - Events
 - Attributes
- Customizable reporting features
- Search feature
- Data synchronization
- History tracking

Additional Requirements (Value adding)

- Information storage on the equipments using RFID tags
- Map (as basic navigation aid)
- Inspection wizard
- Alerts and guidelines
- Long range detection of some equipments

Notes: Based on the discussion with Mr. Lanthier and Mr. Gallant, it is suggested that the software should provide the ability to store comments about the layout change during the maintenance activity since these changes are frequent and are not logged systematically.

Also the changes could be sent based on the software reports to the FM office for further map changes.

Preliminary Hardware Design

Based on the previous discussions, requirement analysis and several meeting and on job visits the following design is suggested

The system is composed of two types of tags attached to location of the items (Location tags, L.T.) and the items themselves. (Item tags I.T.)

The inventory of the system is tracked by the location of the items and following the guidelines and standards there should not be any location without the required safety equipments. This requirement would enforce the system to guarantee the existence of "any" extinguisher on place for a specified location and there is no need to assign a specific extinguisher in one location. Although there is no need to keep the same extinguisher to one location, the type of the extinguisher at that location needs to be checked, meaning the type of the extinguisher is considered as one of the location properties.

The existing maintenance software is running on a PC and the inspectors are carrying the tablet PCs during the inspection. For further cost saving the proposed system is planned to use the same PC as the host for the softwares and RFID controllers.

The RFID system is composed of Tags, antenna, reader and the middleware software. The chosen RFID reader is in PCMCIA form factor and can be mounted on the available PCs.

The proposed readers are chosen to have embedded antenna and there is no need for external antenna.

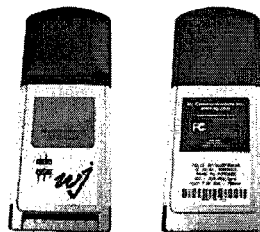

Figure C-1 - Passive PCMCIA Reader

The system is designed based on using UHF (ultra high frequency) range of RFID. The frequency range is in the ISM band which is free and can be used without license.

The decision is made based on the UHF band (868 MHz to 915 MHz) properties listed below.

- Active and passive, read-only, read-write, or WORM transponders are available in this range.

- Offers higher range capability, higher data transfer rates, and faster identification compared to lower frequencies in large volumes.
- UHF transponders have the potential of being less expensive than LF and HF transponders.
- Good penetration through non-conductive materials and non-conductive liquids.
- Provides a good balance between range and performance, especially for multiple transponder reading.
- EPC and ISO standardization is happening mostly in this range.

Based on the requirements and also considering cost issues, the passive RFID is proposed for the system. The passive system is considerably cheaper and can mostly satisfy the requirements in the project. With the proposed passive system, cheap tags with relatively higher range are attached to the location as location tag (L.T.) and cheaper tags with shorter range are attached at the items (I.T.). L.T.s provide the ability for the software to detect the locations to be inspected in the few meter range. After doing the inspection, the data would be written on the items in the short range avoiding fraud and guaranteeing the completion of the actual inspection procedure.



Figure C-2 -Short Range Passive Metal Tag

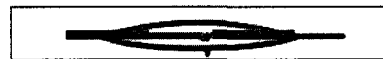

Figure C-3 - Long Range Passive Metal Tag

The tags are in the form of stickers that could be easily attached to locations and extinguishers and also to valves.

Using the standard passive tags would satisfy all the project needs except for the "area survey" to detect all tags on a certain floor.

Another scenario is to add the active tags to certain components. The active tags can be detected from far distance. This would satisfy the need for area survey and detect the items from a distance, also they contain more memory space and some other data could be stored on the tags, such as maintenance history.

However, active tags are considerably more expensive and would be suitable for components that:

- Need to be detected from a distance
- Are hidden under surfaces
- Need more information to be stored on them

Table C-1 - Passive RFID Hardware

	Manufacturer	Model	Protocol	Nominal Readability Distance
Reader	WJ Communication	MPR5000	EPC global C0,C1G2	3 m
Tag	Avery Dennison	AD-900	EPC global C1G2	3 m
	Avery Dennison	AD-820	EPC global C1G2	2 m

Note that having both active and passive tags on the items requires the system to use two readers at the same time, one for passive tags and the other one for the active tags.

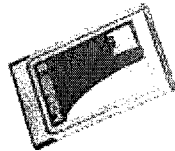

Figure C-4 - Active PCMCIA RFID Reader

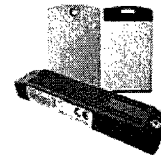

Figure 0-4 -Active RFID Tag

Table 2 shows the hardware components that should be added to the system in order to support long range detection.

Table C-2 - Active RFID Hardware

	Manufacturer	Model	Protocol	Nominal Readability Distance
Reader	Identec Solutions	i-Card 3	Proprietary	100m
Tag	Identec Solutions	i-Q8	Proprietary	100m

The proposed software supports the long range tags and reader.

Required resources:

- Information

- Pyrosecure and G.E.Edwards consultancy
- Concordia FM info and requirement gathering and consultancy
- Hardware
- Software
- Programmers

Tentative Estimated Costs (to be revised)

- Hardware
 - RFID related hardware (tag, reader)
 - Tablet PC
 - Casing and enclosures
 - Server
- Software development
- Supporting softwares (database, operating systems, APIs)
- Installation
- Training and support

Table C-3 - Estimated Cost for passive scenario

	Model	Qty.	Unit Cost (\$)	Total Cost (\$)
Reader	MPR5000	1	700	700
Tag – I.L.	AD-900	3,500	2	7,000
Tag – I.T.	AD-820	3,500	1	3,500
Portable PC	HP	1	0 (Available)	0
Casing and enclosures	-	7,000	0 (available)	0
Servers	HP	2	2,000	2,000
Software Development	-	1	20,000	20,000
Supporting softwares	Microsoft	1	10,000	10,000
Installation of tags	-	7,000	0.5	3,500
Training and support	-	1	2,000	2,000
				50,700

Table C-4 - Additional Cost for 200 Active Tags

	Model	Qty.	Unit Cost (\$)	Total Cost (\$)
Reader	ID card 3	1	800	800
Active tags	i-Q8	200	38	7,600
Software Development	none	1	0	0
Installation of tags	-	200	0.5	100
				8,500

Development Steps and Schedule

- Completed steps
 - Requirement analysis (refer to section "Required Features")
 - Conceptual design
 - Software design(Fig.7 and Fig.8)
 - Hardware selection
- Phase I (2009)
 - Approval of proposed specification and plan
 - Software customization
 - Hardware purchase
 - Pilot Test
 - Pilot result analysis
- Phase II (2010)
 - Full deployment

Preliminary system structure

The system is composed of RFID tags and readers, a portable PC and a backend server.

The local database is installed on the handheld PC and the connectivity between the server and the PC is not necessary for operation. Having the local database, the system can work standalone by saving data locally and on the tags.

The data could be synchronized with the central database while the connection is provided.

The information is stored on the local database and also is backed up on the server and is synchronized with the central database. This scenario provides a high level of data redundancy. Note that the data is also stored on the RFID tags attached to the inspected objects as well.

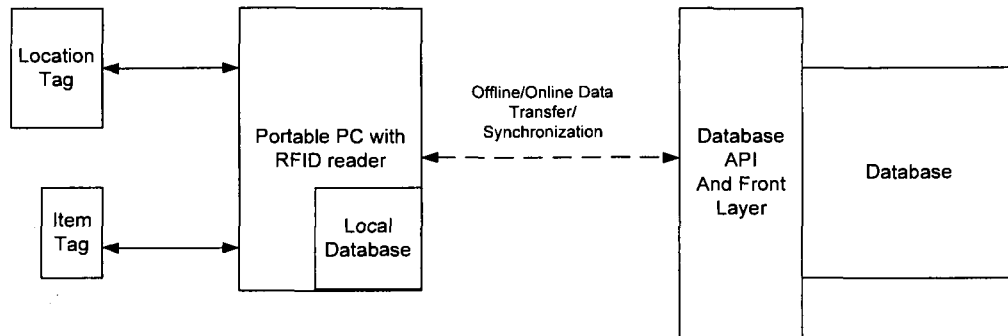

Figure C-6 - System Structure

Note: In the first phase the data can be stored locally on the handheld PC and later backed up on the server. This would provide less implementation cost.

Preliminary Process Flow Chart

The major processes in software flow are:

- The inspector logs in to the system by entering username/password or scanning his ID card. (1)
- After authentication and authorization he selects the type of operation. One of the three major operations could be chosen. (2)
 - **View data:** for retrieval of stored information on the tags (L.T. or I.T.) or the data base information such as the history of the objects
 - **New Maintenance:** to start new inspection/maintenance activity
 - **New Repair:** this operation is for assisting the repair shop processes and can be completed in the future if needed.

View Data

- There are two methods for retrieving information. (3)
 - Scanning the I.T./L.T.
 - Entering the ID or the description of the item/location
- The scanned tag or entered ID, is either L.T. or I.T. (could be easily differentiated by identifier bit), Base on the type of the tag, stored information on the tag and also database records for that item is shown. (4)
- The inspector has the option to view the history of the item/location from the database. (5)

New maintenance

- For the new maintenance activity there are three options available for the inspector: (6)

- **Load job:** the task list (the list of fire extinguishers that are planned to be inspected by inspector through operation management system) can be loaded. After choosing this option the list is loaded from the database and the inspector would do the job as planned. After loading the lists the related maps with the target extinguishers are shown in the software. (7)
- **Scan area:** the inspector have the option to scan the area to detect the location tags. The tags that are sensed by the RFID reader in that area are shown in the related map.(8)
- **Enter location info:** the inspector chooses this option if he knows which building or floor he wants to inspect. By selecting the desired location from the drop down menus, he selects the location and the related map with the sign of extinguishers is shown in the software. (9)

After deciding on the inspection target (the extinguisher that is going to be inspected) the inspector would find the item using the map.

- Inspector starts the inspection/maintenance activity. (10)
- The location tag (L.T.) is scanned first and the information on the tag is shown. The inspector has the option to edit the data on the location tag but since the location tag information are fixed data, the option to edit is not considered are major step.(11)
- The inspector then scans the item tag. (I.T.) (12)
- Based on the previous information recorded on the tag, related alerts are shown. (13)

The sample alerts are:

- Hydrostatic test needed
- Recharging needed
- The extinguisher is obsolete
- Extinguisher type is invalid

The alerts are automatically generated by software based on the information on the items and also the time and date on the PC. It would eliminate the chance for human error.

- The wizard is the major part of the software; it includes a user friendly checklist to log the inspection/maintenance results. The status of the extinguisher and also the name of the defected part can be entered in the system using user friendly interface. The inspector can also get the instruction for inspecting different types of extinguishers if needed.(14)
- After completing the actual inspection and entering the information about the possible defective part or condition of the extinguisher. The software shows the data to be written in the database and tag and request for confirmation.(15),(16)
- If the information is correct the data is written on the Item tag.(17)
- The location information to be written on the item tag (I.T) comes from the L.T. that is previously scanned. Also the current date is taken from the PC and is automatically added to the Item tag.

- The data is also stored in the local database. (17)
- The inspector can go to the next extinguisher to inspect or terminate the process. (18)

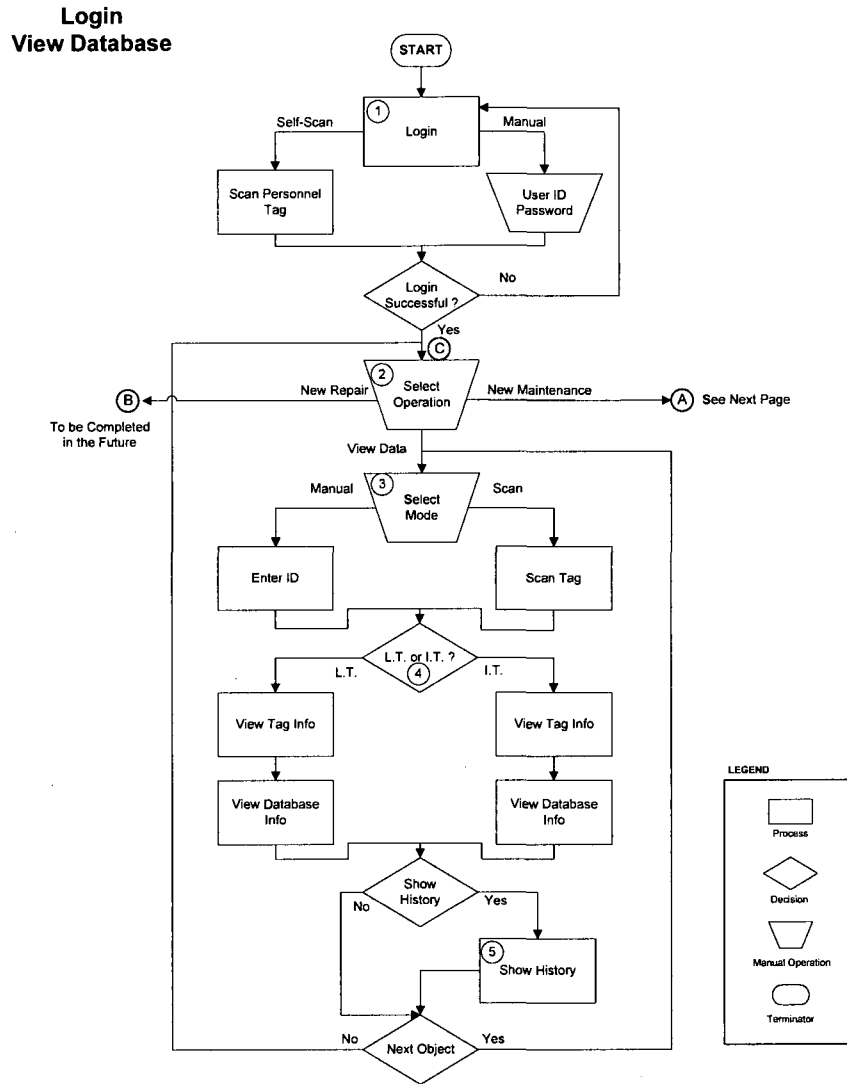

Figure C-7 - Login and View Data Flowchart

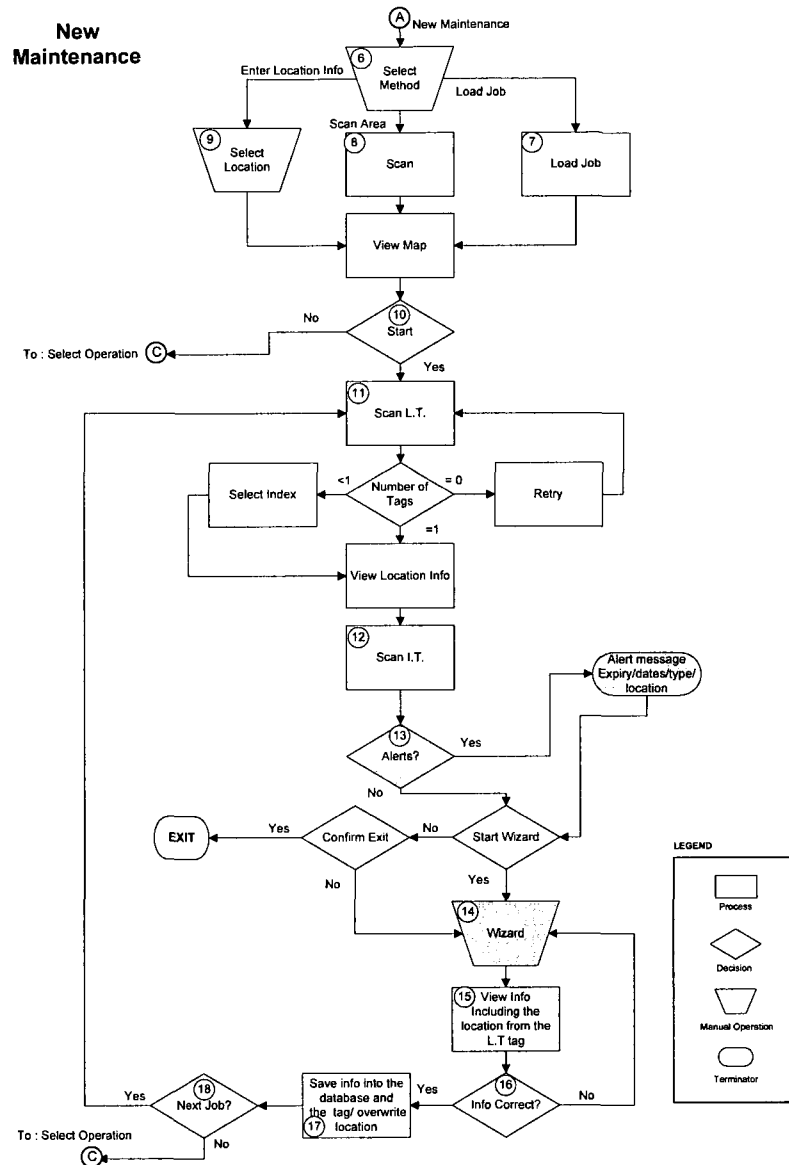

Figure C-8 -New Inspection/Maintenance Flowchart

Appendices

Appendix 1: Data structure

The memory size of standard passive tags is 96 bits, the following tables are the data structure for storing information on the tag memory.

Since there are two type of tag , L.T. and I.T. , the stored data structure is different based on the tag type.

Table C-5 - Item Tag (I.T.) Data Structure

Item No.	Category	sub-category	Field Name	Size (bits)	Number of Possible Options
1		Identifier	Tag identifier	1	2
2		ID	Component Type	8	256
3			Component Model	5	32
4			Serial Number	18	262,144
5	DATA	Dates	Last inspection Date	14	16,384
6			Manufacturing date	14	16,384
7		Location	Building Number	7	128
8			Floor Number	4	16
9			Room Number	10	1,024
10		Component status/info	Status	8	256
11			Defective Part	7	128

Table C-6 - Location Tag (L.T.) Data Structure

Item No.	Category	sub-category	Field Name	Size (bits)	Number of Possible Options
1		Identifier	Tag identifier	1	2
2	Data	Location	Building Number	7	128
3			Floor Number	4	16
4			Room Number	10	1,024

Appendix 2: Sample GUI interface of developed software

Appendix 3: Passive RFID Reader (MPR5000) Datasheet

<http://www.wj.com/documents/Datasheets/MPR5000.pdf>

Appendix 4: Item Tag (AD-820 AD-821) Datasheet

http://www.rfid.averydennison.com/_media/us/pdf/datasheets/AD820_821.pdf

Appendix 5: Location Tag (AD-900) Datasheet

http://www.rfid.averydennison.com/_media/us/pdf/datasheets/AD900.pdf

Appendix 6: Active RFID Reader (i-Card3) Datasheet

http://www.identecsolutions.com/fileadmin/user_upload/PDFs/product_sheets/i-CARD_3_V5.3_Eng.pdf

Appendix 7: Active Tag (i-Q8) Datasheet

http://www.identecsolutions.com/fileadmin/user_upload/PDFs/product_sheets/i-Q8_V5.3_Eng.pdf

APPENDIX D - SAMPLE SITE VISIT AND TEST REPORTS

Report on JMSB Site Visit

Attendees: Ali Motamedi, Sonia Rodriguez, Yu Sato

The initial meeting was with Mr. Jean Rivard, the supervisor for HVAC installation.

Question: How many lots haven't been shipped yet?

Answer: 15 floor-lots number 1 and 2 on section 4 and 5 and 6- lot number 2 on section 3 on the same floor

Q: When the lots are going to be shipped?

A: there is no fixed schedule and they are going to be ordered based on the finished job and also available space on the floor

Q: What is the approximate time that you receive the lots?

A: in a month

Q: How long does it take from ordering a lot till receiving the part on site?

A: 2 or 3 days

Q: Who is the contact person in the company that we can communicate to help us?

A: Matheew St Gelais (project manager)

Mr. Rivard suggested that we attach the tags on control units since they are more valuable and also spread in the floor. They should be inspected and since they are under false ceiling they are hard to find after finishing the building.

The control units are being manufactured by another company, so they do not have the standard tags that other HVAC parts do.

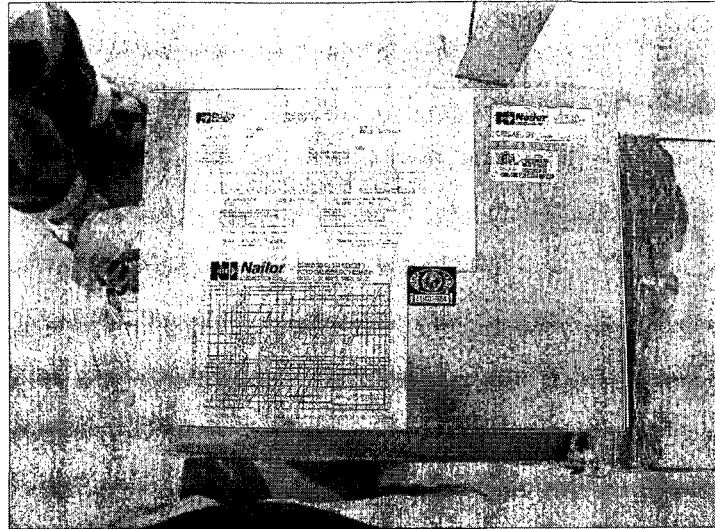

Figure D-1 Control units on the floor

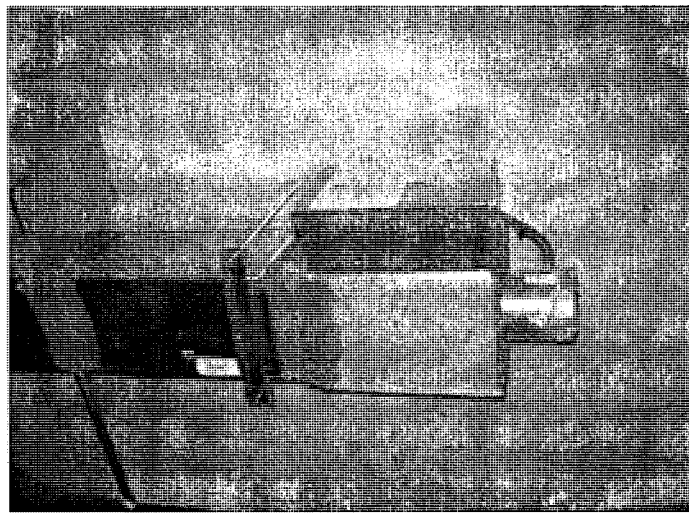

Figure D-2 Control Units Installed

- We have also explained about the experiment that we are going perform and explain about the usage of RFID in the future
- Rivard mentioned that the tags could be easy damaged during the shipment and also installation

Q: can we install the tags inside the part

A: yes

The part should be assembled on the floor before final lifting and installation, the instruction about how to attach the part are available on the map and also is noted on the paper tag attached to the parts.

In some installation , the identical part should be attached to make an extended duct, since the identical parts has the same tag, there is no unique identification and the only extra information on the attached paper-tag is the quantity of the part in the lot

While assembling the parts, if identical units are used, the workers take the easiest accessed one first because there is no difference between the identical parts.

Note: since RFID tag is unique, the order of assembling the identical parts is important so, it would add extra work to find the right part.

RFID Test:

Active tags:

Equipments used: ID CARD3 and i-Q8 tags, IQ diagnostics software

Test: Ping tag

Power: Maximum

Frequency of the reads = 2 sec

The tags were place on the surface of the ducts and we were able to read them from distance (+20m).

Tags attached inside the pipes and ducts that were in the pile of duct were not readable at any distance because of interference.

The readability pattern of the tags that are attached to ducts that are in the pile is random because of the complicated signal bouncing and abortion.

We were able to read the tags when we were close to the pile with certain angles.

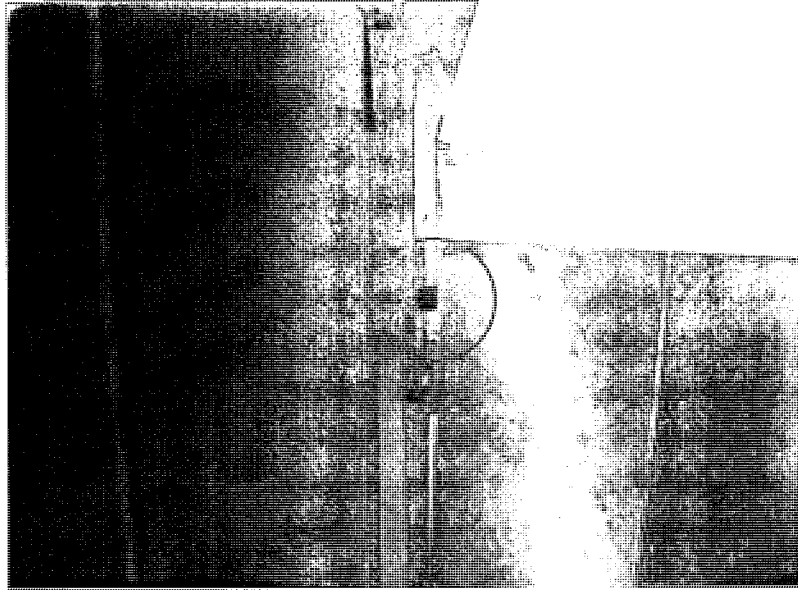

Figure D-3 Active Tag Installed Outside a Duct Next to Another Duct

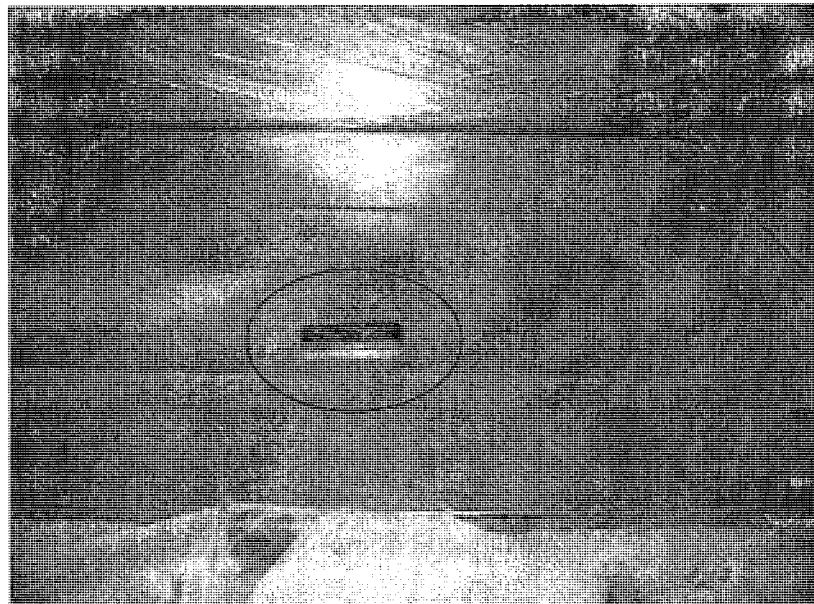

Figure D-4 Active Tag Installed Inside a Duct.

Passive tags

Equipment: WJ reader, Metal craft B30001, Dietz E50001, Omni-ID Max, Omni Id Flex, Alien ALL-9460-02

Test: Inventory check

Power: 27 dB

Frequency of the reads 0.1 sec

The tags were attached in the surface of the ducts and also the control unit and the readability was tested based on the maximum distance that the tag is readable. We obtained these conclusions:

Tag	Distance
Metal craft B30001	5 cm
Dietz E50001	7 cm
Omni-ID Max	20 cm
Omni ID Flex	26 cm
Alien ALL-9460-02	3 cm

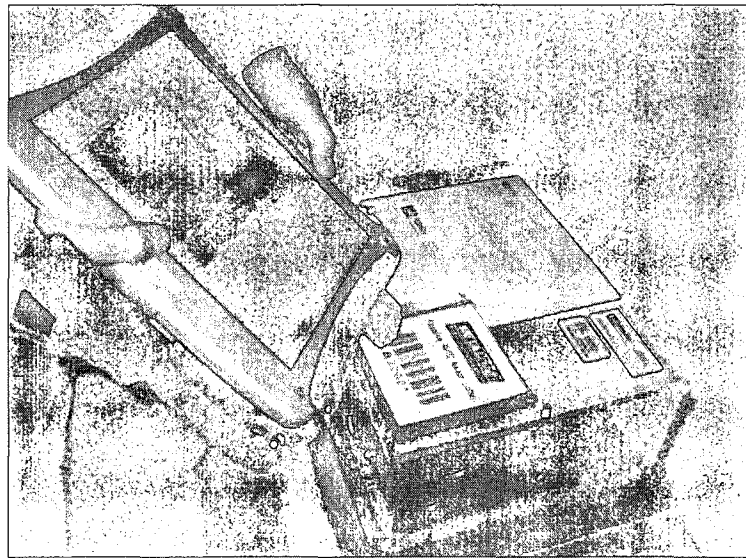

Figure D-5 Testing of a Passive Tag with Sponge Protection

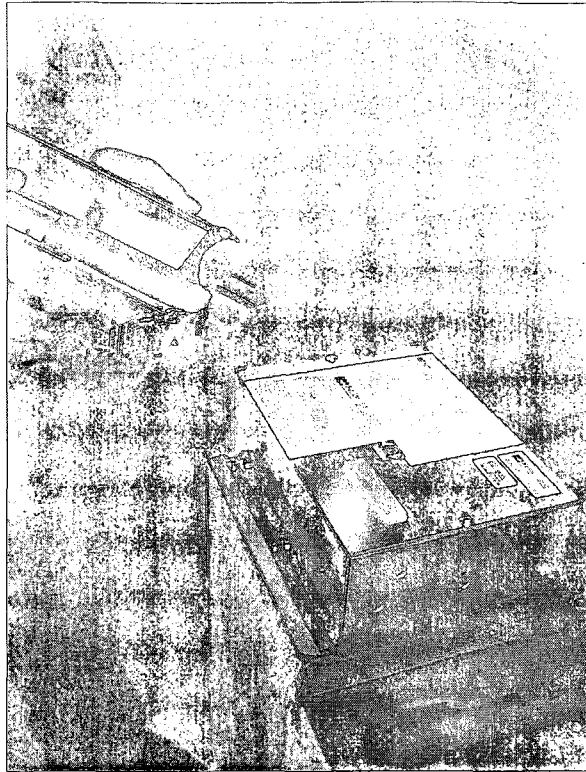

Figure D-6 Testing of a Metal Friendly Passive Tag

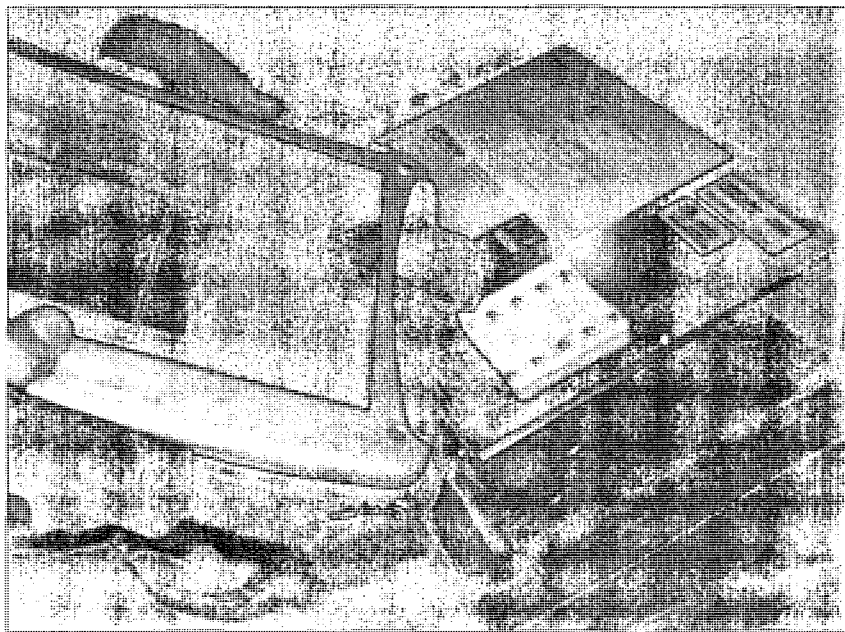

Figure D-7 Testing of Passive Tags in Sticker Form

APPENDIX E – SUMMARY OF SAMPLE HARDWARE TEST RESULTS

Group Coordinator and Test Designer: Ali Motamedi

Capstone Project Team: Ziad Nahas, Carl Medawar, Ousama Zaweet, Achraf Dagher, Wiktor Borowiec, and Hristiyan Angelov.

Hardware Test

Objectives

- To determine the optimum distance and angle at which a tag is efficiently read.
- To pilot test passive tags on short ranges and measure their performance over a recurring period of time.
- To pilot test active tags on short ranges and especially on long ranges. Moreover, we will measure their performance over a recurring period of time through periodic trials.
- To assess the ability of both passive and active tags to cope with interference within an environment, such as metal or massive objects.
- To improve significantly both the quality and the maintenance processes in the E.V building of Concordia University.
- To determine at the end of the testing phase which type of tag would be of paramount importance and efficiency to improve significantly both the quality and the maintenance processes.
- To determine if both types of tags will eventually work and be constantly read by the RFID readers when directly attached to the fire extinguishers.
- To provide an efficient solution in case tags are not being read by the RFID reader due to interference from the fire extinguisher surface. Such a solution would isolate both the tag and the fire extinguisher from each other.

Testing Environment

According to the fact that the purpose of this project is to perform the integration of an RFID-based maintenance system at Concordia University's E.V. Building using RFID

hardware equipment; it is decided to perform the hardware assessment in the 9th floor as shown in Figure below:

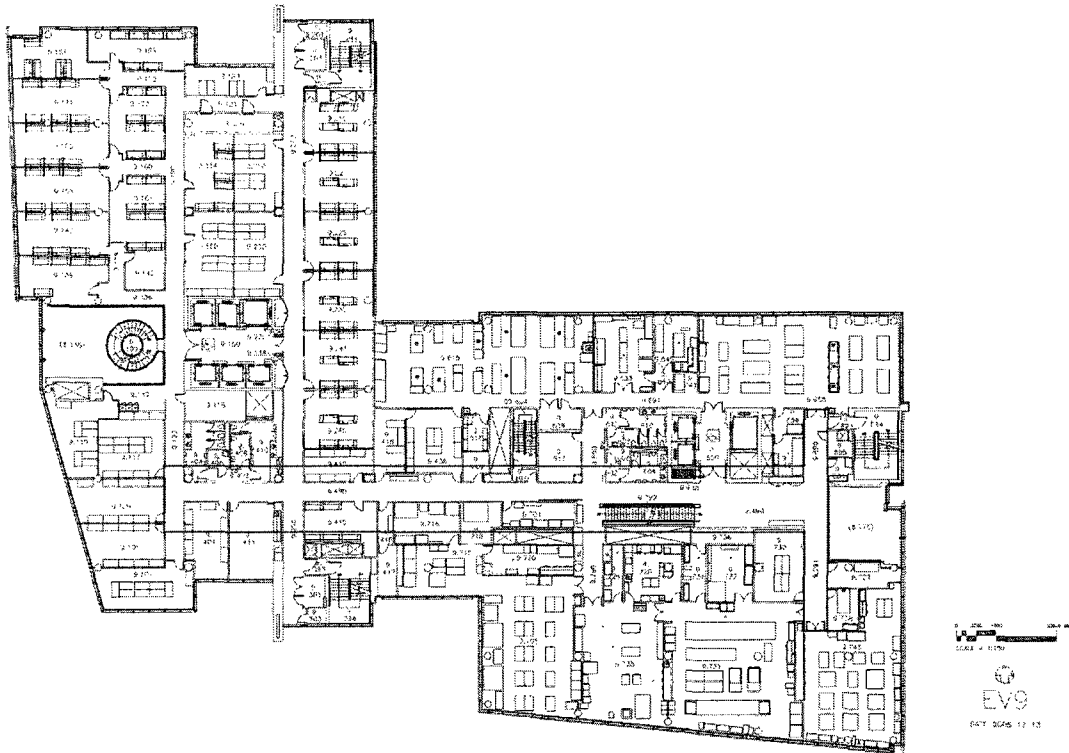

Figure E-1 Map of 9th Floor of the E.V Building at Concordia University

The map contains a highlighted area in red which indicates the area where the test was performed. This area is chosen for testing as it represents a moderate environment which is less subject to the excess of interference due to electronic devices. Nevertheless, the presence of several wireless hotspots within this area is still could be found.

Hardware Components/Equipment

Since active and passive tags require different readers, two sets of RFID systems including tags and readers were used:

Passive Tags Testing Equipment

ThingMagic Mercury 4 RFID Reader equipped with ThingMagic Dual Antenna TM-ANT-NA-2C (Figure E-2) is used to test the readability range of two types of 915MHz EPC Class 1 Gen2 passive tags.

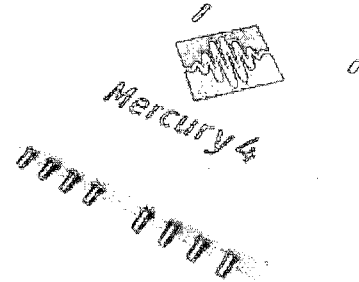
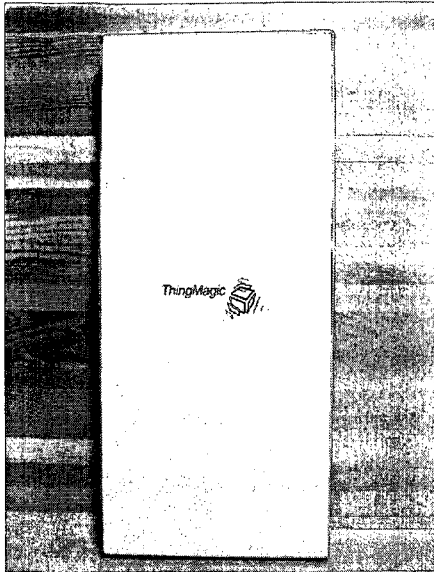
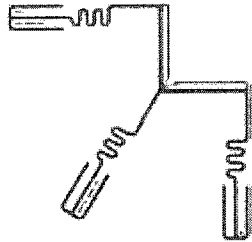

Figure E-2 ThingMagic Dual Antenna TM-ANT-NA-2C and Mercury4 Reader

GEN2, EPC Class 1 standard passive tags that operates in 915MHz that used in the test are : (1) Alien Omni-Squiggle 1.2 , and (2) Alien Squiggle 2.2 (figure E-3).



ALL-9460 (Omni-Squiggle 1.2)



ALL-9440 (Squiggle 2.2)

Figure E-3 Alien Passive Tags

Alien Squiggle® Family of EPC RFID Tags offer similar capabilities such as “Read-Only”, “Read/Write” and WORM (Write Once, Read Many).

Active Tags Testing Equipment

The I-CARD3 PC Card Active Tag Reader was used which is illustrated below in Figure E-4 can transmit and receive data at distances of up to 100 meters (300 feet) from an i-Q tag.

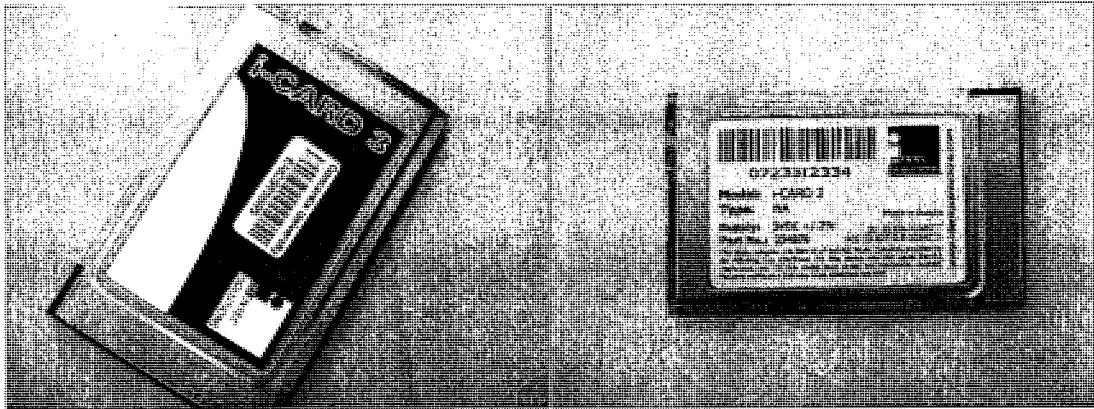

Figure E-4 The I-CARD3 PC Card Active Tag Reader Front/Back

The RFID active tags used are two types of IDENTEC Active Tags: (1) i-Q32T and, (2) i-Q8 (Figure E-5 and E-6) .



Figure E- 5 IDENTEC Active Tag i-Q32T Front/Side Sample

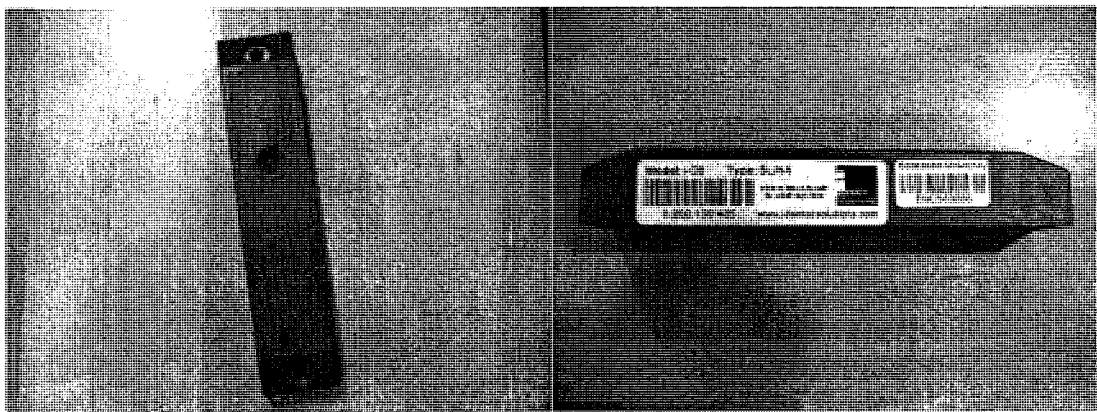

Figure E-6 IDENTEC Active Tag i-Q8 Front/Side Sample

Passive Tags Readability Tests and Results

All our tests were based on a strict procedural process that we brought forth as the implementation of the tests progressed. Having the ThingMagic Mercury4 RFID Antenna placed vertically, in parallel and aligned centered to the midpoint of a tag (which is at a circular directional angle of 90o) will always give the best readability. Figure E-7 and Figure E-8 summarize in a scale the readability range of the ALL-9440 and 9460 tags respectively:

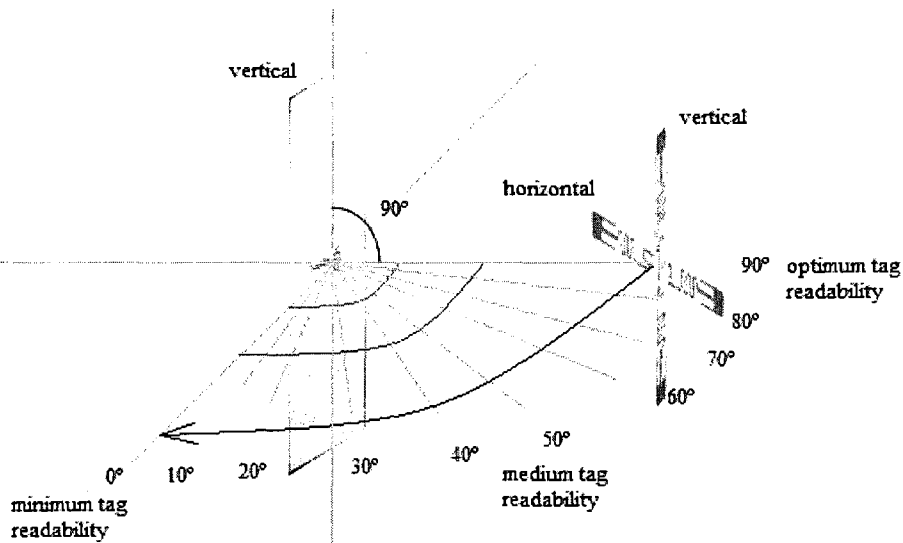

Figure E-7 Readability Range Scale for ALL-9440

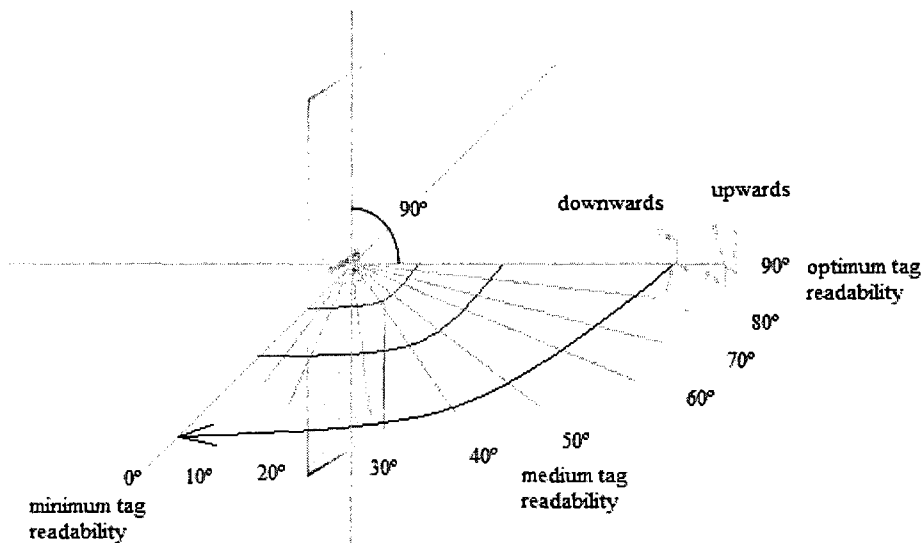

Figure E-8 Readability Range Scale for ALL-9460

The readability of a passive tag decreases as the horizontal circular directional angle decreases from 90o to 0o.

Fundamental Passive Tag Test

The purpose of this basic test was to determine which combination of “antenna-tag” positioning would offer optimum readability at several angles. Nonetheless, we will represent the results for a tag angle of 90o only in Table E-1 below. This test followed the readability scales procedures shown in Figure E-7 and E-8.

Table E-1 Passive Tag Test Sample

Tag ID	Reader Power	Antenna Position	Tag Position	Antenna – Tag Angle	Tag Readability Range
ALL-9440 (Squiggle 2.2)	High Or 32dB	Horizontal	Horizontal	90°	Poor
		Horizontal	Vertical		Poor
		Vertical	Vertical		Medium
		Vertical	Horizontal		High
ALL-9460 (Omni-Squiggle 1.2)		Horizontal	Downwards		Medium
		Horizontal	Upwards		Medium
		Vertical	Upwards		High
		Vertical	Downwards		High

We can clearly see that the ThingMagic Mercury4 RFID Antenna has an uneven and inconsistent transmitting surface. Indeed, a vertically positioned antenna provides always optimum tag readability for both types of tags regardless of the tag positioning. However, a horizontally positioned antenna would always provide medium or poor readability despite of the tag used. Consequently, for the subsequent tests we will always position the antenna vertically to obtain the maximum possible tag readability at an angle of 90o.

Liquid, Metal and Wood Test

The purpose of this materialistic test is to determine the ability of passive tags to cope with interference within the environment. Therefore, we simulated different scenarios which involved fastening the tags to a piece of metal, bottle of water, and wood. Afterwards, we recorded the results obtained for simplicity in Table E-2:

Table E-2 Liquid, Metal and Wood Test

Tag ID	Reader Power	Antenna Position	Tag Position	Matter	Matter Interference Effect on the Readability Range
ALL-9440 (Squiggle 2.2)	High Or 32dB	Vertical	ANY	Metal	Extremely High
				Water	High
				Wood	Medium
ALL-9460 (Omni-Squiggle 1.2)				Metal	High
				Water	High
				Wood	Medium

We can clearly notice that metal has an extremely high interference effect on both passive tags because it reduces the tags readability by approximately 91% and 77% for the ALL-9440 and ALL-9460 respectively.

Second, we can clearly notice that collating passive tags on a fully filled 500mL bottle of water highly interferes with the tag readability as it reduces the ALL-9440 and ALL-9460 readability by approximately 70% and 74% respectively.

Third, we observed from Table 8 that fastening a passive tag on a wooden block provokes interference on a medium scale. Moreover, we can conclude that wood cuts the optimum tag readability by half or approximately 55% and 50% for the ALL-9440 and ALL-9460 respectively.

Fire Extinguisher Test

The purpose of this test is to check if it is possible to make use of passive tags on the fire extinguishers. We clearly noticed that passive tags were not read at all when fastened directly at the front or back the fire extinguisher (regardless of the tag and antenna position). Metal filled of liquid absorbs the signals sent by the reader and the tag.

Fire Extinguisher Solution

To solve the problem, 2mm or 4mm isolation paper was used. The results obtained are recorded in Table 9 below:

Table E-3 Results for the Fire Extinguisher Solution

Tag ID	Reader Power	Antenna Position	Tag Position on Fire Extinguisher	Paper Thickness (mm)	Readability Range (cm)
ALL9440 or 9460	High Or	Vertical	Front	0	0
				2	200
				4	400

We notice that the range increases to 2m by placing both passive tags bended at the front of the fire extinguisher on a 2mm layer. Moreover, when increasing the layer to 4mm the readability range increased to 4m. The integration of an RFID-based system on the maintenance processes on the E.V. Building is feasible by the means of passive RFID tags.

Active Tags Readability Tests and Results

For this experiment, we need to expect that the readability range of both IDENTEC active tags such as Model i-Q32T and i-Q8 is far more superior to the one of the passive tags. In fact, these types of active tags have a maximum expected range of 100m or 300ft according to their specification. The i-CARD 3 is a PCMCIA Type II PC card RFID

Reader with a circular range of 100m or 300ft. This reader performs 360° readings and that the optimal distance is uniformly expected to be 100m within an “interference free” environment.

Basic, Liquid, Metal, Wood and Fire Extinguisher Active Tag Test

The purpose of the elementary test is to pilot test active tags on long ranges. Moreover, the materialistic test is aimed at determining the ability of active tags to cope with interference within the environment. Thus, diverse scenarios were created which involved fastening the tags to a piece of metal, bottle of water, and wood. Lastly, the purpose of the fire extinguisher test is to check if active tags will be usable on fire extinguishers. Overall, the results obtained for all these tests are shown in Table E-4 and E-5 below:

Table E-4 Fundamental Active Tag Results

Tag ID	Reader Power	Matter	Maximum Distance (m)		Signal Drop
			Experimental	Theoretical	
i-Q32T	High	Basic/None	87.62	100	Low
		Metal			
		Water			
		Wood			
i-Q8		Basic/None			
		Metal			
		Water			
		Wood			

Table E-5 Fire Extinguisher Test

Tag ID	Reader Power	Tag Position	Matter	Maximum Distance (m)		Signal Drop
				Experimental	Theoretical	
i-Q32T	High	Front	Fire Extinguisher	87.62	100	Low
		Back		87.62	100	Low
i-Q8		Front		87.62	100	Low
		Back		87.62	100	Low

We can conclude from both tables above that metal, water, wood and the fire extinguisher have no interference effect on the readability range of the active tags. Indeed, we were easily able to reach the distance of 87.62m for both tags with really occasional signal drops in our testing environment (even when the tag is placed in the front or at the back of the fire extinguisher). The signal drops were most probably due to low interferences from electronic devices. In addition, 100m is achievable only if we were testing in a vast location.

Fire Extinguisher in Wall Mount Cage

The purpose of this section is to test the tags by placing them at the front and back of a fire extinguisher. The fire extinguisher is in return placed in a Plastic Wall Mount. The results of the test are presented in Table E-6 below.

Table E-6 Fire Extinguisher within a PWM

Tag ID	Reader Power	Tag Position	Matter	Readability (m)		Signal Drop
				Minimum	Maximum	
i-Q32T (0.200.170.001)	High	Front	Fire Extinguisher	0 to 1.10	20.44	Medium
		Back		0 to 2.00	12.53	High
i-Q8 (0.200.159.485)		Front	+ PWM	0 to 1.16	20.44	High
		Back		0 to 1.52	8.10	Low

Clearly the readability of the active tags is affected significantly when the fire extinguishers is placed inside its plastic wall mount. Moreover, the readability range drops significantly to 20.44m when the tag is placed at the front. When the tag is fastened at the back of the fire extinguisher, the readability distance drops roughly to 8.10m and 12.53m.

APPENDIX F -SAMPLE GUI INTERFACE OF DEVELOPED SOFTWARE

Login window:

The user logs in using username/password.

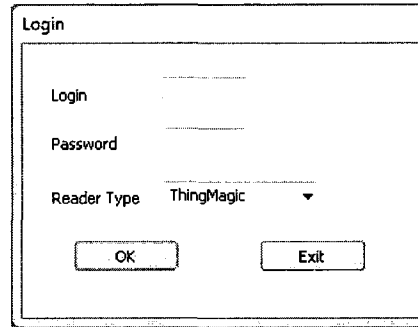

Figure F-1: Login

Selection Operation Window:

The user can select the operation he wants to perform. It is either viewing data or starting a new maintenance activity.

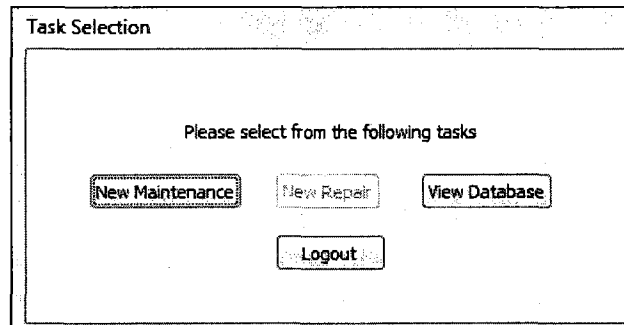

Figure F-2: Task Selection

Logout button: leads to the exit dialog.

Database button: leads to the database, displaying the information stored.

New Maintenance button: gives the chance to load the job. The Load Job dialog appears and it is shown in Figure (3).

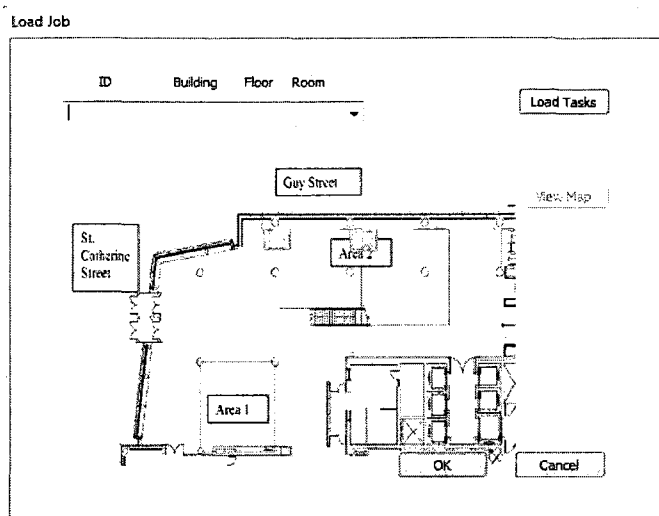

Figure F-3: Load Job

The list of extinguishers that should be inspected is taken from the database after loading the tasks

Read window:

The user connects to the reader and scans the area. The items that are sensed by RFID are shown in the dialog box. The user can change the power of the reader and also the frequency of sending read requests.

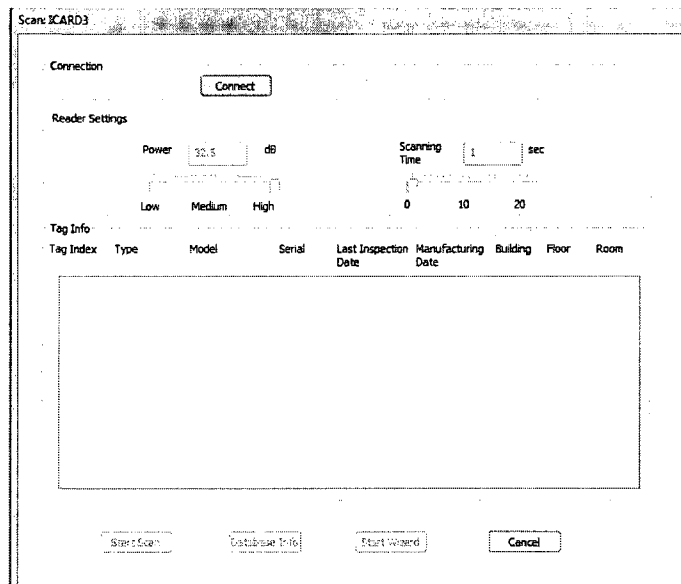

Figure F-4: Read ICARD3

Major steps are:

Establishing Connection:

- **Connect button:** establishes connection with the reader. A confirmation message should appear to inform the user that connection was established successfully.
- All the buttons and display appear enabled after the connection has been made.

Scanning:

- The user should choose the power range (low, medium or high) and specify the scanning time before start scanning.
- **Start Scan button:** will scan for all tags in the reader's readability range. The scanned tags will appear under Tag info. The information stored on the Tags will be displayed (type, model, serial, Last inspection date, Manufacturing date, Building, floor and room).
- **More Info button:** will display additional information related to the tag.
- **Start Wizard button:** will start the Fire Extinguisher Wizard Window.

Wizard Window:

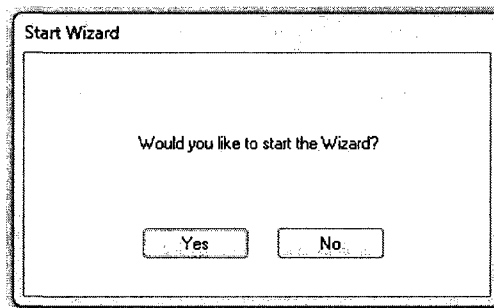

Figure F-5: Start Wizard

In the "Wizard: Fire Extinguisher" window, the user can inspect the Accessibility, Physical Conditions, Gauge Pressure or Overall Condition by chooses from the various options available. This is the phase where the user performs his inspection and updates the information to the tag and database.

- OK button: will disable the whole window and a confirmation button would appear to confirm the changes that the user has made. If the changes made are confirmed, a message will appear indicating that a successful updated was made.
- After data was updated a Next Job window will appear, shown in Figure

Wizard: Fire Extinguisher

Accessibility

Obstructed Missing Sign

Loose Missing Tag

Physical Condition

Integrity of the cylinder

Damaged

Rusted

Dusted

Bended Neck

Tampering

Brocken Seal

Plugged Hose

Missing Pin

Rivet

Gauge Pressure Overall Condition

Figure F-6: Wizard Fire Extinguisher

Database Window:

Database [X]

1- Manual ID Entry

Type:

Model:

Serial:

2- Manual Scan

Figure F-7: Database Selection Method

In the "Database" window, the user has two methods to access the inspection history.

- 1. Manual ID Entry:** this method is used for stationary office computers where the reader is not connected to the machine. In order to see the history of a specific item the user has to enter the type, model, and serial number of that item. Type and model can be selected from a drop down menu.

2. **Manual scan:** This method is suitable for readers attached on portable computers. The user can check the history of an item by simply walking to that item and scanning it.

The result of these two methods is illustrated in figure 8 below.

Database Information

Object Information									
Object ID	Type	Model	Serial No.	Location ID	Building	Floor	Room	Manufacturing Date	Manufacturer
11	FIRE EXTSH	WBDL-ABC340WH	129641	40945341	EV	0	24	2005-03-15	Strike first

Inspection History																
Inspection Date	Inspector ID	Pressure High	Pressure Low	Dusted	Rusted	Damaged	Missing Pin	Missing Rivet	Broken Seal	Missing Tag	Missing Sign	Bended Neck	Hose	Obstructed	Loose	Overall Condition
2008-04-02	1001	no	no	no	no	no	no	no	no	no	no	no	no	no	no	yes
2008-04-01	1001	no	no	no	no	no	no	no	no	no	no	no	no	no	no	yes
2001-01-01	1001	no	yes	yes	no	yes	yes	no	no	no	no	no	no	no	no	yes

OK

Figure F-8: Object History and Information

APPENDIX G - SOLVING THE RFID COST-BENEFIT EQUATION

The following is the summary of an article by Shahram Moradpour published in RFID Product News Journal (Moradpour 2005).

Many factors play a role in determining RFID technology's costs and benefits. For example, costs can be fixed, such as investment in new tools and processes to install and test tags. Conversely, costs can be recurring, such as the cost of the RFID tags themselves, or those associated with applying the tags on cases and pallets.

Similarly, benefits can be direct, such as the reduction in shrinkage or buffer stock. They also can be indirect, such as better customer service due to more detailed and accurate visibility of ship time and date of arrivals.

ELEMENTS OF COST

The costs of an RFID deployment can be broken down into three key areas: hardware, software, and services. Hardware costs include the cost of tags, readers and antennae, host computers, and network equipment (cables, routers, and so on). Software costs include those associated with acquiring new middleware and application software. Service costs include the cost of installation, tuning, integration, process reengineering, and support and maintenance.

Tags-key considerations

Tag costs are one of the key considerations in any RFID deployment. Tags come in various shapes and sizes based on application requirements. These factors affect tag pricing significantly. Other factors such as range, onboard memory, read/write capability, and active/passive configuration also impact the cost of tags. Two types of costs are associated with tags: acquisition cost and preparation cost.

Acquisition Costs: The Electronic Product Code (EPC) passive UHF tags-typically used to satisfy Wal-Mart, DoD, and other retailers' mandates-cost around 40 cents each. These so-called "smart labels" often are embedded inside adhesive labels, which is all that is required for the majority of case and pallet tagging applications. Significant volumes in hundreds of millions, however, can yield discounts of 20% to 30%.

Preparation Costs: Tag acquisition costs are not the only factor driving the overall cost of tags in an RFID deployment scenario. One must factor in related costs as well. For example, when using smart labels, the cost of the RFID label printer/encoder (and possibly a robotic applicator) should be factored in. Mounting tags on a metal surface or a container filled with liquid may require special mounting accessories so that the tag can be read properly by a reader. Smart label printer/encoders can cost anywhere between \$5,000 to \$25,000 (when equipped with a robotic applicator). Mounting hardware or other specialized tag packaging can sometimes double the price of a single tag.

		Special Considerations
RFID tags	\$0.05 to \$1.00	<ul style="list-style-type: none"> • Cost is recurring • Mounting accessories or specialized packaging can double the tag cost • Printer/encoder and label applicator costs \$5,000 to \$25,000
Antennae	\$500 to \$5,000	<ul style="list-style-type: none"> • Additional antennae cost \$500 or more • Handheld readers cost \$1,500 and up
Middleware	\$25,000 to \$100,000	<ul style="list-style-type: none"> • Not necessary unless new middleware or new applications cannot run on existing system
Reader appliances	\$8,000 to \$10,000	<ul style="list-style-type: none"> • Cost is often per site/location • A reader appliance with built-in middleware can cost significantly less (\$8,000 to \$10,000) • Middleware can also be a built-in feature of the software application
Host applications	Varies	<ul style="list-style-type: none"> • RFID-enabled version of your existing application software may be available for an upgrade fee
Installation and wiring	Varies	<ul style="list-style-type: none"> • Depends on site conditions, existing infrastructure, and set-up and project requirements
Integration and Business Process Reengineering	\$0 to \$1 million	<ul style="list-style-type: none"> • Basic integration can be provided in the RFID-enabled version of existing application software • Full integration can take years and offer long-term payoff
Support and Maintenance	20% to 25% of overall project cost	<ul style="list-style-type: none"> • Includes training and replacement cost of failing equipment • Cost is recurring yearly

Figure G-1 Summary of RFID Costs

Readers and antennae

Reader range, multi-frequency handling capability (agile readers), and antennae capability affect reader costs. Reader prices, with one or two external antennae, vary from \$1,500 to more than \$5,000 for readers used in rugged industrial environments. Additional antennae can cost \$500 or more. Handheld readers typically combine the antenna and the reader in one package, costing more than \$1,500.

Host computer, middleware, and host applications

The host computers typically run the RFID middleware software-responsible for collecting, filtering, and routing RFID tag data-and other applications such as warehouse management and inventory control. Depending on the type of application, a host computer system infrastructure can run anywhere from a few thousand dollars to hundreds of thousands of dollars.

The cost of standalone RFID middleware can be anywhere from \$25,000 to \$100,000 and up, and includes a site license (e.g. for a single plant or warehouse location). A reader appliance, on the other hand, could provide similar functionality at a cost of \$8,000 to \$10,000 per appliance. The cost of application software depends on the application. In

some cases, an existing application, such as a warehouse management system, will need to be upgraded to an RFID-enabled version of the application. In many cases, vendors of such application software provide built-in RFID middleware, thereby eliminating the need to install and integrate a separate middleware infrastructure.

Installation and tuning

Installation of all these components-tags, readers and antennae, host computers, and related network infrastructure-can indeed be complicated.

On the packaging floor or in a distribution warehouse, new power connections and other network cabling might need to be provided to install the RFID hardware infrastructure in various locations. Depending on the environment, additional gear may be required to set up a network, whether it is wired Ethernet or wireless. Separately, tuning plays a critical role in successful implementation of an RFID application. This refers to activities such as tag/reader placement or shielding to get optimum performance. The engineer can tune the reader and antennae for specific situations, or use shielding to block RF noise emitting from other devices.

Finally, it is not possible to put a price on the cost of installation and tuning without a comprehensive site survey and analysis of both the existing infrastructure and the specific requirements for the new RFID project.

Integration and business process reengineering

Full benefits of an RFID deployment can only be realized when the data collected from tagged items is integrated into existing systems and processes to increase operational efficiency and effectiveness. Integration efforts can be modest and entail integration within a company's own operations. Or, the integration can be bolder and cross company boundaries to involve cooperating supply chain partners such as a supplier and its shipping and logistics provider.

A fully integrated and leveraged RFID infrastructure that spans multiple supply chain partners may cost millions of dollars, take several years to implement, and have a payback over an additional three to five years.

Support and maintenance

The on-going support and maintenance of the new infrastructure and re-evaluation of existing processes to maximize the usage of newly available data represent additional costs as well.

Various existing processes may need to be re-engineered to take advantage of the real-time data collected by an RFID system. Different stakeholders may need to be trained on how to use these new processes. Such costs should be factored into planning and cost-benefit analysis to create a clearer picture of the scope of an RFID deployment. A good rule of thumb is to assign somewhere between 20% to 25% of the total project cost to annual support and maintenance costs.

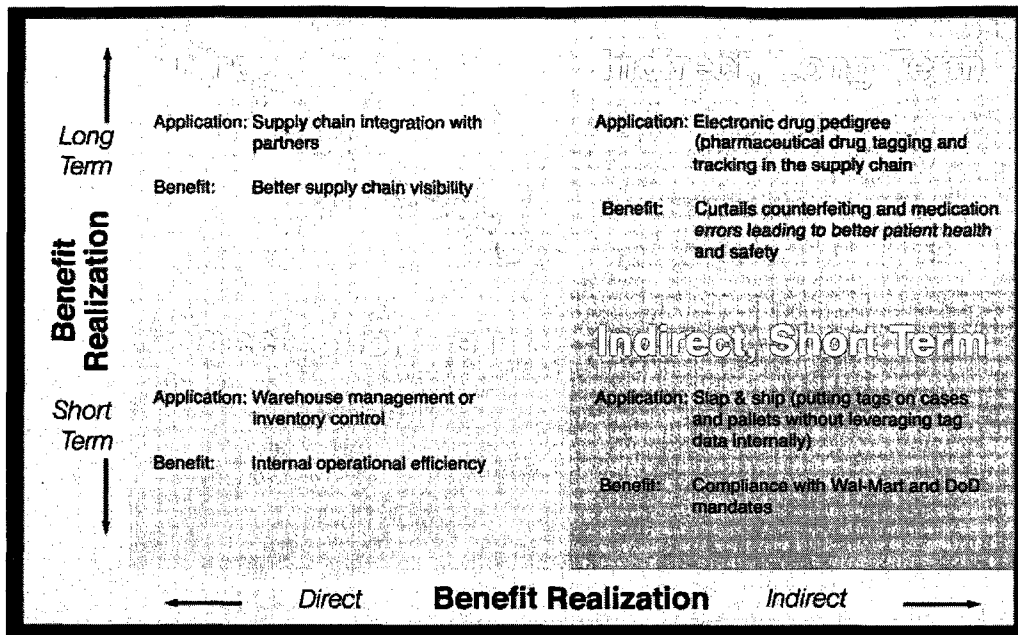

Figure G-2 Summary of Benefits

END RESULT: THE BENEFITS

The benefits of an RFID deployment can be categorized based on time (short-term versus long-term) and tangibility (direct versus indirect). In some cases, a network effect will also be realized. For example, the value and benefits of an RFID deployment will increase exponentially, when the majority of the participants in a supply chain deploy RFID to collect and share inventory and logistics data.

These categories are shown in the Figure G-2. For each quadrant of the matrix, a typical supply chain application and its benefits that fit the characteristics of that quadrant is also shown.

FINDING THE RIGHT BENEFIT LEVEL

In addition to looking at the type of RFID application and its benefits, a company also needs to look at its business environment and organizational readiness for innovation to make the right cost-benefit decision.

LONG- AND SHORT-TERM BENEFITS

In some situations, a company may decide to deploy RFID even if the benefits are indirect or long-term. RFID use in healthcare to deliver the right medicine to the right patient fits in this category. On the surface, the direct benefits of improved productivity seem to be minor. However, the indirect benefits are quite compelling considering that the wrong medicine could harm or potentially kill a patient. In a report recently published by the Institute of Medicine, it is estimated that more than 7,000 patients die every year in hospitals due to medication errors, and many more suffer adverse reactions. If the use of RFID technology can curtail this number, not to mention the reduction in lawsuits against the hospitals, the cost-benefit trade-off is indeed worthwhile, even though the benefits are indirect and long-term.