

Impact of Active Power Curtailment on Overvoltage Prevention and Energy Production of PV Inverters Connected to Low Voltage Residential Feeders

Reinaldo Tonkoski* and Luiz A. C. Lopes

Concordia University – 1455 De Maisonneuve Blvd. West, Montreal, Quebec, Canada - H3G 1M8

Telephone: +1-514-848-2424 Ext. 3080 - Fax: +1-514-848-2802

tonkoski@ieee.org* and lalopes@ece.concordia.ca

*Corresponding Author

Abstract— As non-controllable power sources, photovoltaics (PV) can create overvoltage in low voltage (LV) distribution feeders during periods of high generation and low load. This is usually prevented passively by limiting the penetration level of PV to very conservative values, even if the critical periods rarely occur. Alternatively, one can use active power curtailment (APC) techniques, reducing the amount of active power injected by the PV inverters, as the voltage at their buses increase above a certain value. In this way, it is possible to increase the installed PV capacity and energy yield while preventing overvoltage. This paper investigates a number of approaches for sizing and controlling the PV power generated by 12 net-zero energy houses equipped with large roof-top PV systems in a typical 240V/75kVA Canadian suburban radial distribution feeder. Simulations of a one year period with typical solar irradiance and load profiles are conducted with PSCAD to assess the performance of the different approaches in terms of overvoltage occurrence, sharing of the burden for overvoltage prevention per house and total energy yield of the residential PV feeder.

Keywords-- power distribution, overvoltages, solar power generation, power systems, power quality and voltage control.

1. INTRODUCTION

Distribution systems have been designed and operated under the premise that power flows from the distribution substation to the end users, which only consume power. However, with the addition of intermittent, consumer-owned and non-dispatchable distributed generation (DG) units, current standard procedures for meeting power quality and reliability (PQR) requirements might not be as effective as they are without DG. This has led many electricity utilities to adopt conservative limits regarding the amount of DG that can be installed in distribution networks without an impact assessment study.

Overvoltage is one of the main reasons for limiting the capacity (active power) of non-dispatchable DG units, such as photovoltaic (PV), that can be connected to a low voltage (LV) distribution system [1]. During high PV generation and low load periods, there is a possibility of reverse power flow, and consequently voltage rise, in the LV feeder [1-8]. This problem can be avoided, without conservatively limiting the capacity of the DG units, by using inverters with active power curtailment (APC) schemes. These allow the inverters to inject maximum available power from the dc source, as long as the ac bus voltage is below a certain value. Above this value, the injected power is reduced (curtailed) linearly with the ac bus voltage increase. The option of active power curtailment for overvoltage prevention looks very attractive because it requires minor modifications in the DG's inverter control logic. Besides, it is only activated when needed, thus minimizing the amount of curtailed active power also known as output power losses (OPL) [1].

The use of droop based APC techniques for overvoltage prevention in a LV radial distribution feeders with a number of distributed PV inverters was discussed in [9]. There, two APC schemes were considered. In the first (conventional) one, all PV inverters had the same droop coefficients. It was shown that overvoltage can indeed be prevented for varying conditions of solar irradiance and consumer load. However, while the PV inverters of the houses located close to the LV transformer never experienced power curtailment, those more downstream did, and frequently, significantly reducing their revenues from PV production. This problem was minimized with a new APC scheme that shares the effort required to prevent overvoltage among all PV inverters. In such a case, the droop coefficients of the PV inverters are different, calculated based on their position in the distribution feeder. The drawback of this technique is that it increases the total amount of power curtailed for preventing overvoltage. It should be noted that the results presented in [9] were all based on instantaneous values as the net power produced by the PV feeder varies in time.

PV system owners are particularly interested on the energy yield (revenue) they will get from their systems, which will be affected by the overvoltage prevention schemes. Considering the stochastic nature of residential load and PV generation, a fair assessment of the impact of those schemes on the PV revenues requires a long term study with typical load and solar irradiance profiles. This is done in this paper for a LV residential feeder benchmark with net-zero energy houses, considering not only the APC schemes investigated in [9], but also a passive method where overvoltage is prevented by limiting the installed PV capacity to an appropriate value.

This paper is organized as follows. Section 2 presents the voltage operating limits of LV feeders employed in Canada. Section 3 discusses the principle of voltage droop based APC. In Section 4 the LV system under study is introduced. Section 5 presents the design considerations and simulation results for four case studies. In the first case, the houses present enough installed PV capacity for net-zero energy operation, yearly based, that can lead to overvoltage in the LV feeder. In the second, the installed PV capacity is reduced to avoid overvoltage. The third and fourth cases consider different droop based APC schemes. Simulations with PSCAD are used for comparing the occurrence of overvoltage and also the net energy injected into the system (primary of the LV transformer) for the four cases. The conclusions are then stated in Section 6.

2. OPERATING LIMITS OF LV FEEDERS IN CANADA

CAN CSA C22.2 No. 257-06 [10] specifies the electrical requirements for inverter-based micro-distributed resource systems interconnection to LV grids in Canada. This standard recommends using the CSA CAN3-C235 [11] as guidance for appropriate distribution system steady-state voltage levels. Based on those standards, for single-phase connection, normal operating conditions (NR – Normal Range) occurs when the voltage level is within 0.917 and 1.042 pu. On *extreme operation conditions*, the steady-state voltage limits are 0.88 pu and 1.058 pu. It is worth mentioning that although networks are allowed to operate under extreme conditions, improvement or corrective action should be taken on a planned and programmed basis. As most Canadian utilities adopt the CAN3-C235 limits, these limits will be adopted in this study.

3. DROOP BASED ACTIVE POWER CURTAILMENT (APC)

APC has been proposed for overvoltage protection in [5, 12] for systems with high penetration of DG. Droop control is a well-known technique used for operation and power sharing among generators connected in parallel, mostly relating active power with frequency [3, 13]. In LV systems, the relationship between voltage and active power is stronger than with reactive power given the highly resistive line characteristics [4, 13]. The main drawback of droop based schemes for overvoltage protection is that they cannot be used in conjunction with unintentional islanding prevention schemes that use the inverters voltage tripping limits as the voltage will not exceed the tripping values and also the ones using active voltage drift. However it

is compatible with frequency drift methods or other methods that monitor the frequency, phase jumps, harmonics or grid impedance.

The droop based APC concept was proposed in [5] to avoid the repeated tripping of overvoltage relays in European grids. The design of the droop parameters was based in the European standards; however the concept's performance was not demonstrated. Usually grid-tie inverters are controlled, as current sources with maximum power point tracking (MPPT) algorithms. It is proposed that the power injected by the inverter be a function of the bus voltage (V) according to

$$P_{inv} = \begin{cases} P_{MPPT} - m(V - V_{cri}) & \forall V \geq V_{cri} \\ P_{MPPT} & \forall V < V_{cri} \end{cases} \quad (1)$$

where P_{MPPT} is the maximum power available in the PV array for a given solar irradiance (kW), m is a slope factor (kW/V) and V_{cri} is the voltage (V) above which the power injected by the inverter is decreased with a droop factor. For $V < V_{cri}$ the inverter injects P_{MPPT} , as most PV inverters do. The proposed method uses local voltage to define how much power should be curtailed from each PV inverter. The droop coefficients of the inverters (m and V_{cri}) can be selected for the inverters to comply with the voltage limits at their connection buses. In addition, they can be used to co-ordinate the PV inverters, for sharing the active power curtailment required for keeping all bus voltages within the acceptable range, without a dedicated communication channel. The logic used to implement (1) is shown in Fig. 1.

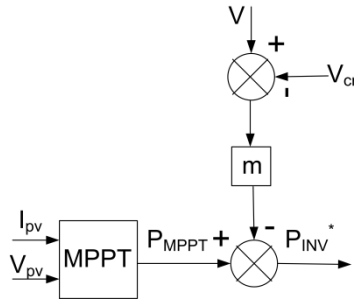

Fig. 1. Droop based APC of the PV inverter.

4. SYSTEM DESCRIPTION

Residential feeders with PV systems can be considered a critical case regarding potential for overvoltage. The typical load profile of residential feeders presents a peak value during night time when there is little or no PV generation. On the other hand, the demand is relatively low when power generation peaks, leading to reverse power flow in the feeder and consequently overvoltage. Conversely, the typical load profiles of commercial and industrial feeders present a good correlation with the typical PV power profile [14, 15], what tends to reduce the likelihood and magnitude of overvoltages, for the same ratio of peak load and peak power generation.

The model of the overhead residential suburban feeder used in this study is described in details in [9]. The PV neighbourhood under investigation, presented in Fig. 2, has a 75 kVA, 14.4 kV - 120/240 V, single-phase LV transformer.

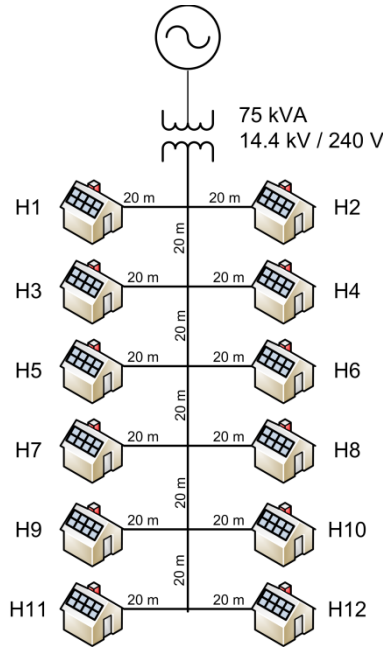

Fig. 2. Overhead residential test feeder configuration.

The voltage in the secondary of the transformer was set at 1.02 pu, in order to allow a maximum 5 % voltage drop in the last customer meter when the 12 houses consume 75 kW without PV generation.

The feeder has a total length of 120 m. The secondary circuit of the transformer, backbone of the feeder, is 100 m long with 2 live wires twisted around a grounded neutral cable (NS 90 3/0 AWG). Along this circuit, there are 12 customers connected in pair to a splice every 20 m. The service entrance consists of 2 wires supported by a steel grounded neutral cable (NS 90 1/0 AWG) and has a length of drop of 20 m. The single-phase line parameters are given in Table 1. Fig. 3 shows the configuration of the transformer model and Table 2 provides the low voltage transformer parameters.

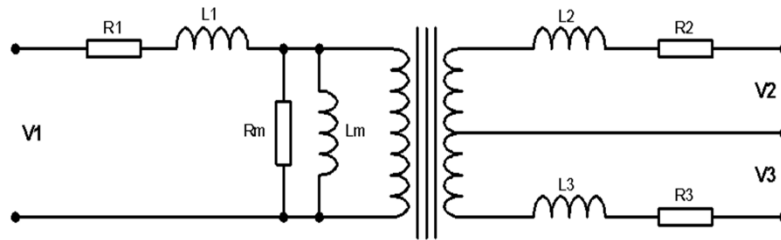

Fig. 3. Transformer's Model.

TABLE 1
SINGLE-PHASE PI SECTION LINES PARAMETERS (PER LINE CONDUCTOR)

	Drop Lines	Pole-Pole Lines
R	0.549 Ω / km	0.346 Ω / km
L	0.23 mH / km	0.24 mH / km
C	0.055 μ F	0.072 μ F / km

TABLE 2

LV TRANSFORMER PARAMETERS

S	75 kVA	L_1	0.02 pu	$L_{2,3}$	0.025 pu
V_1	14.4 kV	$V_{2,3}$	120 V	R_m	500 pu
R_1	0.006 pu	$R_{2,3}$	0.012 pu	L_m	500 pu

The house characteristics for the voltage profile and energy yield studies is based on the Alstonvale net-zero energy solar house (ANZH) [16]. It is able to generate as much power as it consumes in one year. Net-zero energy solar houses are a critical case regarding overvoltages as they require a reasonably large amount of PV systems to be installed to be able to meet the energy needs of each residence and consequently high potential for overvoltages. If normal houses are considered, overvoltages are less likely happen as the installed PV capacity is reduced as compared to net-zero energy solar houses. The ANZH presents a building integrated photovoltaic thermal (BIPV/T) rooftop system, which is capable of generating 22 kWp of thermal energy and 8.4 kWp of electrical energy. The annual electricity generation expected from this house is about 10,000 kWh, which is estimated to match the annual consumption of the ANZH with a plug-in hybrid electric vehicle (PHEV) [16].

The software HOMER is used to estimate the load profiles and PV inverter's power output for each hour of one year. Two yearly load profiles were generated, in order to consider some level of variation in the load profiles in the houses.

Average daily non-electric heated residential load data from [17] for different seasons and also considering weekday and weekends (Fig. 4 and Fig. 5 respectively) were used as reference for HOMER to generate the yearly load data sets.

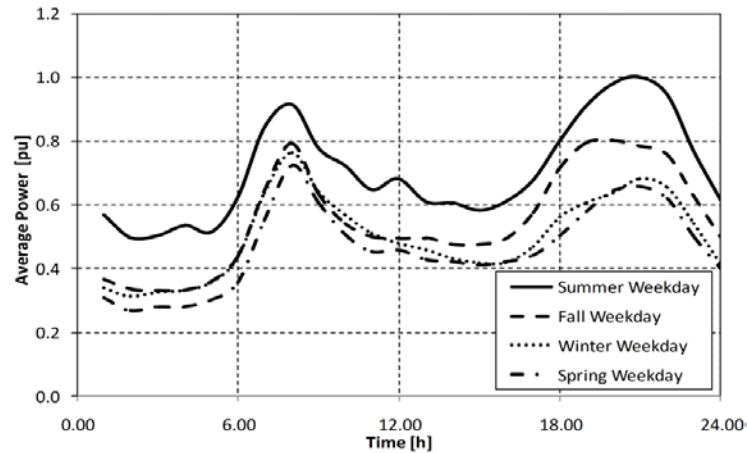

Fig. 4. Weekday average load profiles.

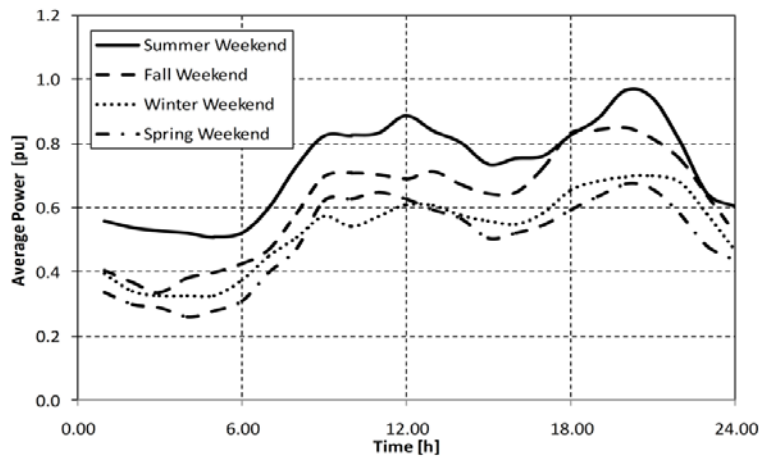

Fig. 5. Weekend average load profiles.

The seasonal data was then scaled in HOMER to have an annual average energy demand of 30 kWh/day. The day-to-day and a time-step-to-time-step random variability factors of 35 % and 20 %, respectively, were considered to represent the high variability characteristic of residential loads. The houses located in the left side of the feeder were attributed this load profile. The load profile box plot obtained from HOMER is presented in Fig. 6. It is shown for each month the mean, the maximum and minimum average power as well as the average daily max and min power. The second load data set, attributed to the houses in the right side of the feeder, was generated using the same procedure, however using the data from [17] time shifted one hour later.

The one year hourly PV inverter output was also estimated using HOMER for the city of Montreal (Latitude 45°55' and Longitude 73°). All the 8.4 kWp PV arrays are considered to be south faced, placed with a slope of 45° and having a derating factor of 0.8. The efficiency of the inverter was assumed as 96 %. Fig. 7 shows PV inverter average power output box plot generated by HOMER.

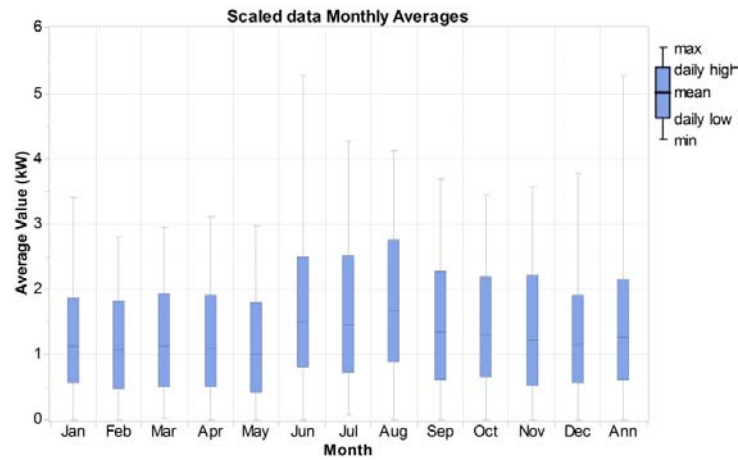

Fig. 6. Scaled load profile monthly averages for load dataset 1.

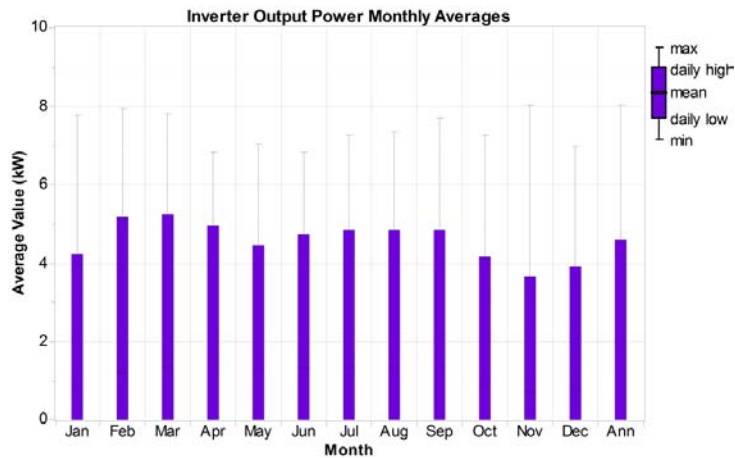

Fig. 7. Monthly averages for PV power generation.

5. SIMULATION RESULTS

The hourly data content of the load datasets and PV inverter output power obtained were used in PSCAD as input for the one year study. For each one of the cases studied, the simulation generated 35052 samples taken along the 8760 hours of the year, obtained through the interpolation of the input data, so that there is a sampling time of about 15 min.

Four case studies are investigated to verify the system's voltage and energy yields for the original net-zero energy PV neighbourhood, using reduced installed PV capacity to avoid overvoltage and with the proposed droop based APC schemes.

5.1. BASE CASE

The first case corresponds to the standard approach where the PV inverters operate with MPPT until, if ever, the voltage at their point of connection reaches 1.1 pu, when the basic inverter protection for voltage trip limits [18, 19] shuts down the PV inverters.

Fig. 8 presents the histogram of the voltage in the last house. It shows the number of occurrences at a certain voltage level. The vertical line indicates the 1.058 pu threshold where overvoltage occurs. There one sees that there are a number of cases of overvoltage in this bus. The maximum voltage found was 1.088 pu, recorded in H 12 on January in a mild clear day, where the load in the system was low and the generation was close to its maximum value. The minimum voltage registered was 0.96 pu. In addition, from the data obtained, one calculates that the average voltage presented was 1.017 pu, with a standard deviation of 0.018 pu.

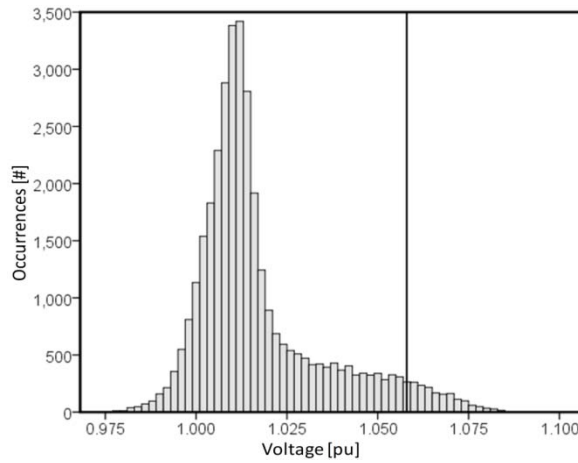

Fig. 8. Histogram of the voltage in the last house - number of occurrences in one year period at a certain voltage [pu] - Base Case.

Fig. 9 shows the percentage of time that overvoltage happened in each even house [%] when the event occurred. Houses 1 to 4 did not present any overvoltage during the year under study. The results for the odd houses are similar so they are omitted in the paper. For 5 % of the samples there was overvoltage (voltage above 1.058 pu) at the last house of the feeder (H 12) and as the houses gets closer to the transformer, the occurrence of overvoltage at their buses is reduced.

Fig. 10 shows the percentage of the occurrences of overvoltage by month. There one sees that overvoltage will occur in 7.9 % of the samples in February, the worst month of the year on this regard. It should be noted that the ANZH is a non-electric heated house, so winter does not necessarily increase the electrical power demand. For the whole year, overvoltage will occur in 5 % of the total samples.

Fig. 11 presents the histogram for the power flow in the primary of the transformer. It shows the number of occurrences at a certain power level. Negative values mean that power flows from the grid to the houses. The range for the power flow in the transformer goes from -60 kW to 84 kW.

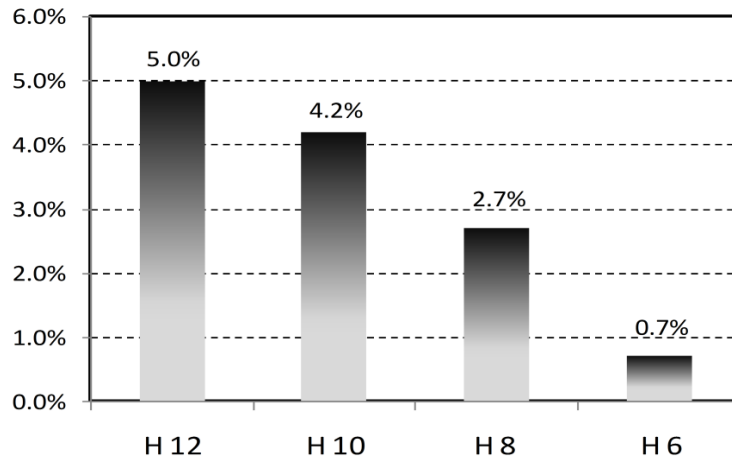

Fig. 9. Overvoltage occurrences in each even house [%] where the event happened.

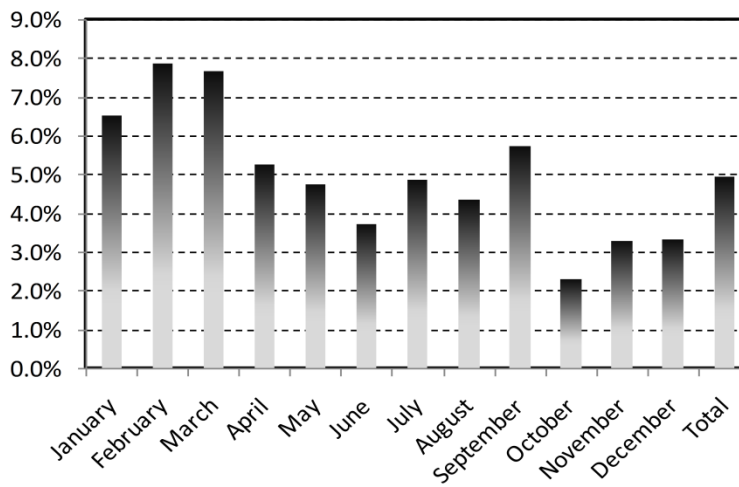

Fig. 10. Overvoltage occurrences by month [%].

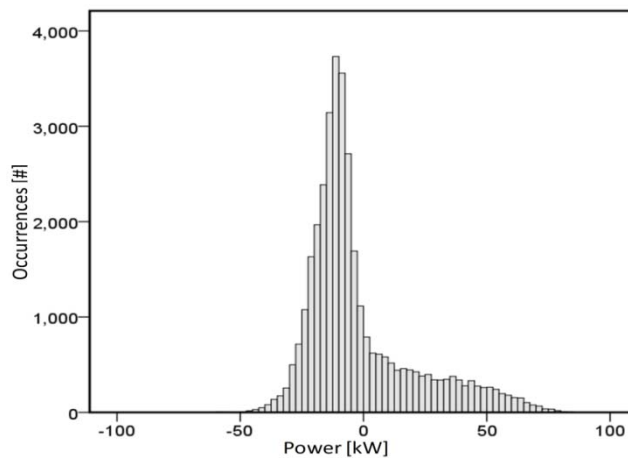

Fig. 11. Histogram of the power flow in the primary of the transformer - number of occurrences of a certain power [kW] - Base Case.

In addition, from the data obtained, one calculates that the transformer is on average loaded about -2 kW, thus, the houses consumed more power than they generate, with a standard deviation of 22 kW.

5.2. REDUCING THE INSTALLED PV CAPACITY (RED. PVCAP)

The second case considers that the installed PV capacity was reduced from 8.4 kWp to 5 kW per house. This reduction was

defined based on the sensitivity matrix of this system presented in [9] and it was calculated in order to avoid overvoltages considering that the maximum voltage found in the feeder in the previous case was 1.088 pu.

Fig. 12 presents the histogram of the voltage in the last house. There are no cases of overvoltage neither in this bus nor in the feeder and the maximum voltage found was 1.058 pu, as expected by the design approach, also recorded in H 12 in January. The minimum voltage registered was 0.96 pu. In addition, from the data obtained, one calculates that the average voltage presented was 1.013 pu, with a standard deviation of 0.012 pu.

Fig. 13 presents the histogram for the power flow in the primary of the transformer. It varied between -60 kW and 47 kW. In addition, from the data obtained, one calculates that the transformer is in average loaded about -8 kW with a standard deviation of 14 kW.

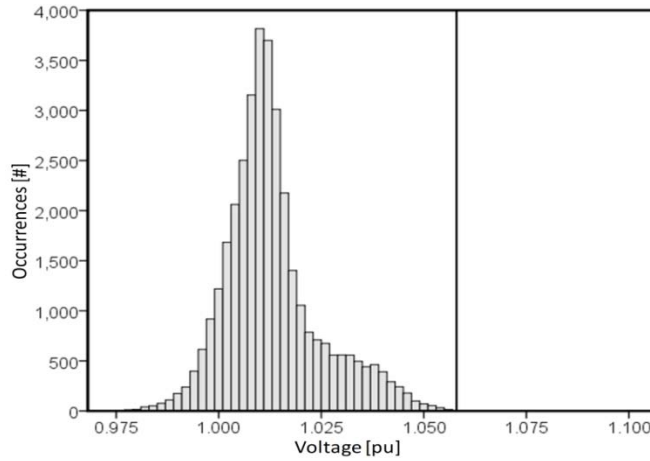

Fig. 12. Histogram of the voltage in the last house - number of occurrences at a certain voltage [pu] - Red. PV_{Cap.}

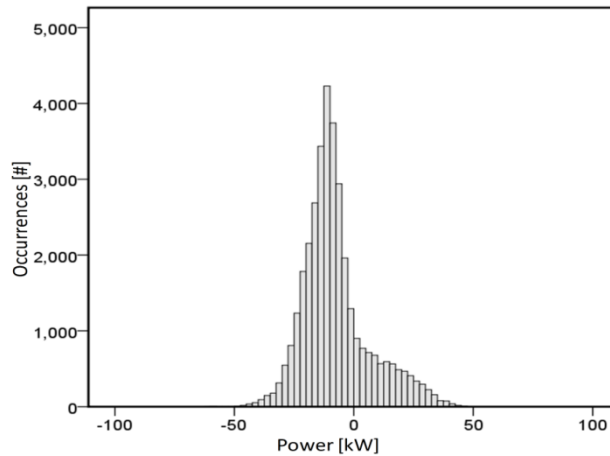

Fig. 13. Histogram of the power flow in the primary of the transformer - number of occurrences of a certain power [kW] - Red. PV_{Cap.}

5.3. DROOP-BASED APC DESIGN

The third case considers that all PV inverters are controlled with droop based APC and present the same droop coefficients. The droop parameters were selected so that APC only occurs for local voltages between 1.042 pu (maximum voltage level in NR) and 1.058 pu (*extreme operation conditions*). V_{cri} is defined as the voltage where the curtailment starts: 1.042 pu (250 V in a 240 V rated system.)

The droop coefficient m is obtained using (2). The PV inverters' active power is curtailed linearly with the local voltage (V), starting at V_{cri} up to the voltage limit of 1.058 pu, or 254 V, when the PV inverters should not inject any power. The m coefficient is obtained dividing the power to be curtailed in this period by the voltage variation. For an 8.4 kW PV system, it is:

$$m = \frac{P_{pv \max}}{V_{1.058 \text{ pu}} - V_{1.042 \text{ pu}}} = 2.1 \frac{\text{kW}}{\text{V}} \quad (2)$$

Fig. 14 presents the histogram of the voltage in the last house. There are no cases of overvoltage neither in this bus nor in the feeder and the maximum voltage found was 1.052 pu, also recorded in H 12 in January. The minimum voltage registered was 0.96 pu. It is interesting to notice that, as power curtailment occurs for voltages between 1.042 pu and 1.058 pu, the voltage occurrences that were above 1.058 pu in Fig. 8 moved to the region that the APC operates in Fig. 14. The occurrences for voltages below 1.042 pu are the same in Fig. 8 and in Fig. 14. In addition, from the data obtained, one calculates that the average voltage was 1.016 pu, with a standard deviation of 0.015 pu.

Fig. 15 presents the histogram for the power flow in the primary of the transformer. It varied between -60 kW and 53 kW. Note that due to the use of APC, the maximum power injected by the PV neighbourhood into the MV grid decreased from 84 kW, without APC, to 53 kW. This is the “cost” of preventing overvoltage when the net power produced by the PV neighbourhood is high. In addition, from the data obtained, one calculates that the transformer is on average loaded at about -3.0 kW with a standard deviation of 19.3 kW.

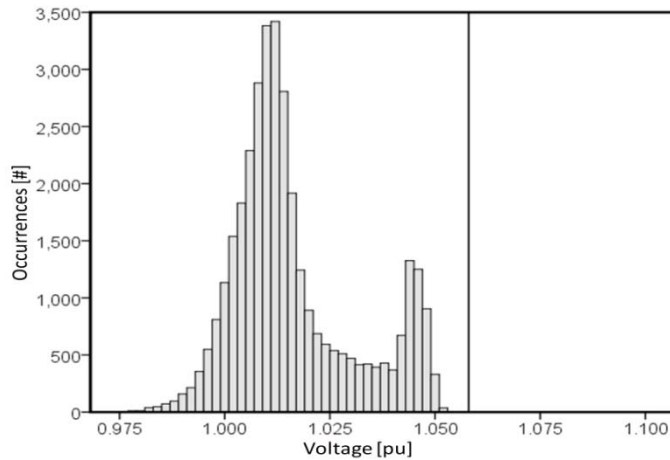

Fig. 14. Histogram of the voltage in the last house - number of occurrences at a certain voltage [pu] - APC.

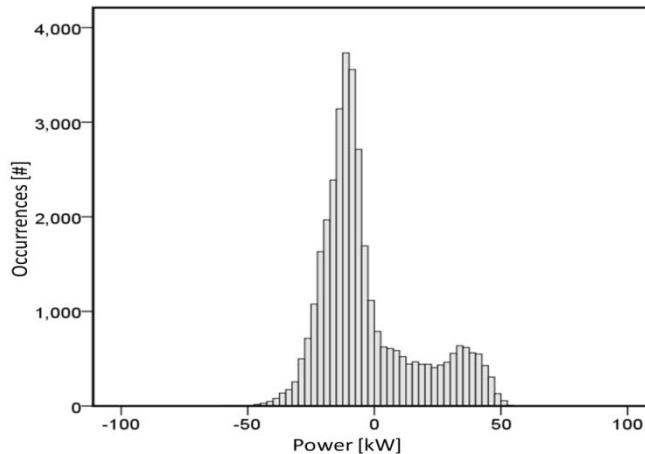

Fig. 15. Histogram of the power flow in the primary of the transformer - number of occurrences of a certain power [kW] - APC.

5.4. DROOP-BASED APC DESIGNED FOR OPL SHARING

In this last case, the inverters are also controlled with droop based APC, but the droop parameters of the inverters are different so that the OPL are shared equally among all houses. The design of the droop coefficients for APC with OPL sharing (APC-

OPLS) is based on the voltage sensitivity of the system [4] obtained running a Newton-Raphson load flow in Matlab for the backbone of the LV feeder. The first order sensitivity analysis method was used to obtain a quantitative measure of the impact of the variation of the active and reactive power of the inverters on the variation of the magnitude of the voltage at the radial distribution feeder. The complete design approach is presented in [9], assuming a maximum voltage without curtailment of 1.088 pu (261 V). The coefficients used in the simulation are shown in Table 3.

Fig. 16 presents the histogram of the voltage in the last house. There are no cases of overvoltage neither in this bus nor in the feeder and the maximum voltage found was 1.058 pu, also recorded in H 12 in January. The minimum voltage registered was 0.96 pu. It is interesting to notice that as the power curtailment operates from 1.042 pu of voltage to 1.058 pu, the voltage occurrences that were above 1.058 pu moved to the region that the APC operates. As in the previous case, the occurrences for voltages below 1.042 pu are the same for Fig. 8, Fig. 14 and Fig. 16. In addition, from the data obtained, one calculates that the average voltage presented was 1.016 pu, with a standard deviation of 0.015 pu.

TABLE 3
DROOP COEFFICIENTS FOR EACH PV INVERTER

House	V_{cri} [pu]	m [kW/V]	House	V_{cri} [pu]	m [kW/V]
1/2	1.026	3.51	7/8	1.039	0.99
3/4	1.031	1.73	9/10	1.041	0.88
5/6	1.036	1.22	11/12	1.042	0.82

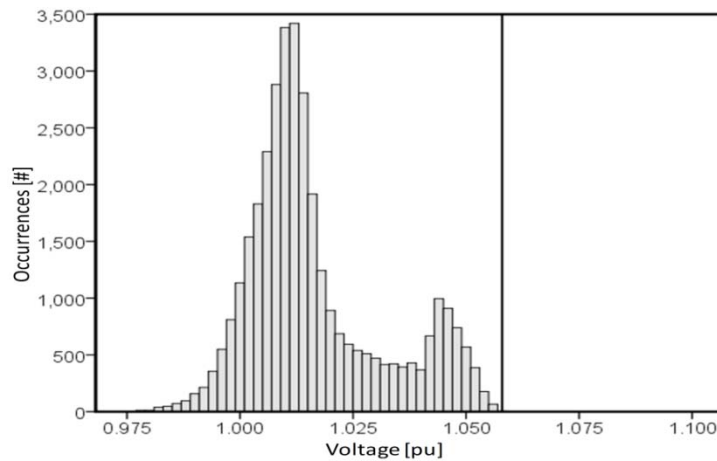

Fig. 16. Histogram of the voltage in the last house - number of occurrences at a certain voltage [pu] - APC-OPLS.

Fig. 17 presents the histogram for the power flow in the primary of the transformer. It varies between -60 kW and 47 kW. Note that the maximum power injected by the PV neighbourhood into the MV grid decreased using APC-OPLS. It is smaller than the 53 kW obtained with APC. This is the “cost” of sharing the OPL required for preventing overvoltage among all inverters/houses. In addition, from the data obtained, one calculates that the transformer is in average loaded about -3.4 kW with a standard deviation of 18.6 kW.

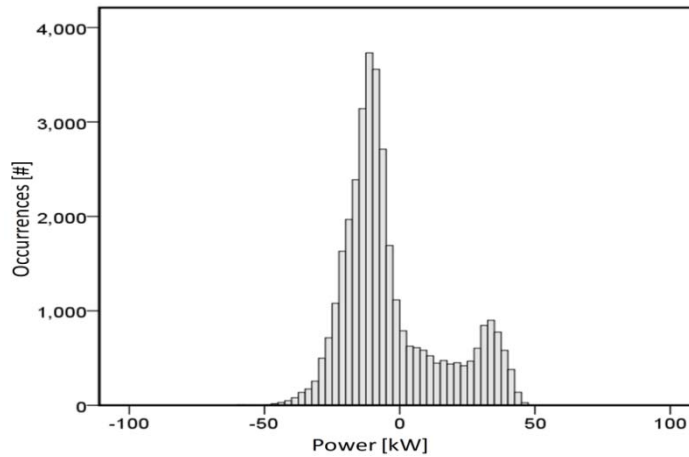

Fig. 17. Histogram of the power flow in the primary of the transformer - number of occurrences of a certain power [kW] - APC-OPLS.

5.5. YEARLY ENERGY YIELDS

For each of the four cases considered in this study, the energy generated and consumed by each house, by the PV neighbourhood as a whole and overvoltage occurrences were obtained.

Table 4 shows the energy produced and the overvoltage occurrences in the feeder for each month. The months between March and September are the ones with the largest energy generation. The base case has the highest overall energy production, but creates overvoltage in the feeder.

TABLE 4
PV INVERTERS ENERGY GENERATED AND CURTAILED BY MONTH

Month	Energy Generated [MWh]				Overvoltage Occurrences [%]			
	Base	Red. PV_{Cap}	APC	APC-OPLS	Base	Red. PV_{Cap}	APC	APC-OPLS
January	8.2	4.8	7.2	6.9	6.5	0.0	0.0	0.0
February	9.7	5.7	8.7	8.3	7.9	0.0	0.0	0.0
March	12.2	7.2	11.0	10.5	7.7	0.0	0.0	0.0
April	11.3	6.7	10.4	10.1	5.3	0.0	0.0	0.0
May	11.6	6.8	10.8	10.5	4.7	0.0	0.0	0.0
June	11.7	6.9	11.1	10.9	3.7	0.0	0.0	0.0
July	12.2	7.2	11.5	11.2	4.9	0.0	0.0	0.0
August	12.1	7.1	11.3	11.1	4.4	0.0	0.0	0.0
September	10.9	6.4	10.0	9.7	5.7	0.0	0.0	0.0
October	8.2	4.8	7.8	7.6	2.3	0.0	0.0	0.0
November	6.3	3.7	5.7	5.6	3.3	0.0	0.0	0.0
December	6.9	4.1	6.3	6.2	3.3	0.0	0.0	0.0
Total	121.2	71.6	111.8	108.6	5.0	0.0	0.0	0.0

Comparing the approaches for avoiding overvoltage, simply reducing the installed PV capacity in each house from 8.4 kWp to 5 kWp, results in a decrease of 41% in PV power generation.

Using the APC techniques, one can avoid overvoltage in the feeder while keeping the original 8.4 kWp/house. The reduction in PV power generation was around 7.7% when all inverters present the same droop parameters. In such a case, the houses farthest from the transformer have more energy curtailed as can be seen in Table 5. Houses H 12 and H11 lose about 20 % of their energy output by the curtailment, while the houses closer to the transformer can profit from all its production. On the other hand, with the APC-OPLS technique the energy losses due to power curtailment are shared among all the houses. Every house

loses about 10 % of energy leading to an overall decrease of 2.7 % in the energy produced by the PV neighbourhood with respect to the original APC.

TABLE 5
PV INVERTERS ENERGY GENERATED AND CURTAILED BY HOUSE FOR ONE YEAR

House	Energy Generated [MWh]		Energy Curtailed [MWh]	
	APC	APC-OPLS	APC	APC-OPLS
H 1/2	10.1	9.2	0.0	0.9
H 3/4	10.1	9.1	0.0	1.0
H 5/6	9.9	9.0	0.2	1.1
H 7/8	9.2	9.0	0.9	1.1
H 9/10	8.5	9.0	1.6	1.1
H 11/12	8.1	9.0	2.0	1.1
Total	111.8	108.6	9.4	12.6

Table 6 presents the net energy in the primary of the LV transformer, sent by the PV neighbourhood to the grid, what takes into account the losses in the feeder and in the LV transformer itself. It shows that in that specific year, the PV neighbourhood consumed more electricity than it produced in all cases. When the houses are equipped with 8.4 kWp each, the amount of energy required from the grid is relatively small, 16 MWh, but the feeder is subject to overvoltage. These can be avoided by simply reducing the size of the PV arrays to 5 kWp/house but the amount of electricity imported increases to 66.3 MWh. Instead, one can have the 8.4 kWp/house PV arrays, producing up to this power when the net generation is not high enough to cause overvoltage. Whenever net power generation tends to become too high, it is curtailed with either APC or APC-OPLS, what allows the reduction of electricity required from the grid to 26.2 MWh and 29.3 MWh, respectively.

TABLE 6
TOTAL NET ENERGY GENERATED TO THE GRID [MWh]

Month	Base	Red. PV _{cap}	APC	APC-OPLS
January	-2.2	-5.6	-3.1	-3.4
February	0.9	-3.1	-0.2	-0.5
March	1.6	-3.4	0.4	0.0
April	1.4	-3.2	0.6	0.3
May	2.4	-2.4	1.5	1.3
June	-2.3	-7.1	-2.9	-3.1
July	-1.8	-6.8	-2.5	-2.8
August	-3.9	-8.9	-4.6	-4.8
September	-1.0	-5.5	-1.9	-2.2
October	-3.8	-7.2	-4.2	-4.3
November	-4.5	-7.1	-5.0	-5.2
December	-3.6	-6.4	-4.2	-4.4
Total	-16.7	-66.3	-26.2	-29.3

6. CONCLUSION

This paper discussed the feasibility of implementing a solar neighbourhood with 12 net-zero energy solar houses in a typical 75kVA, 120/240 V, single-phase, Canadian suburban residential feeder. Using yearly load and PV generation profiles, it was shown that having the desired installed PV capacity for yearly net-zero energy operation, in a particular year, the energy import of the neighbourhood would be about 13% of its needs, but there would be overvoltage occurrences in the feeder. Reducing the installed PV capacity can prevent overvoltages, however it was found that the solar neighbourhood would have to import around 50% of its electricity needs. Alternatively, one can use the desired installed PV capacity that caused overvoltage and use

inverters with APC to reduce PV generation only when there was the possibility of overvoltage due to high generation and low load. In this way, using the basic APC approach, the electricity import from the MV grid was limited to around 20% of its needs. In the basic APC scheme, all PV inverters use the same droop coefficients but their contribution, in terms of APC, for overvoltage prevention was different. Houses located downstream on the feeder were required to curtail more energy than the others (close to transformer), affecting their revenues. This problem can be eliminated with the APC-OPLS method that shares the output power losses (OPL) among all inverters. The difference on energy curtailed between houses located downstream and upstream becomes negligible. However, this feature comes at the expense of smaller (~3%) energy yield for the residential PV feeder with respect to the basic APC scheme.

7. ACKNOWLEDGMENT

Funding for this publication was provided by the Government of Canada through the Program on Energy Research and Development (PERD) and by the Solar Buildings Research Network under the Strategic Network Grants Program of the Natural Sciences and Engineering Research Council (NSERC) of Canada.

8. REFERENCES

- [1] Y. Ueda, K. Kurokawa, T. Tanabe, K. Kitamura, H. Sugihara, Analysis Results of Output Power Loss Due to the Grid Voltage Rise in Grid-Connected Photovoltaic Power Generation Systems, *IEEE Transactions on Industrial Electronics*, 55 (2008) 2744-2751.
- [2] S. Cobben, B. Gaiddon, H. Laukamp, WP4 – Deliverable 4.3 - Impact of Photovoltaic Generation on Power Quality in Urban Areas with High PV Population, in, 2008.
- [3] J.C. Vasquez, R.A. Mastromauro, J.M. Guerrero, M. Liserre, Voltage Support Provided by a Droop-Controlled Multifunctional Inverter, *IEEE Transactions on Industrial Electronics*, 56 (2009) 4510-4519.
- [4] R. Tonkoski, L.A.C. Lopes, Voltage Regulation in Radial Distribution Feeders with High Penetration of Photovoltaic, in: *IEEE Energy 2030 Conference 2008*, Atlanta, 2008, pp. 1-7.
- [5] K. De Brabandere, A. Woyte, R. Belmans, J. Nijs, Prevention of Inverter Voltage Tripping in High Density PV Grids, in: *19th EU-PVSEC*, Paris, 2004.
- [6] P. McNutt, J. Hambrick, M. Keese, D. Brown, Impact of SolarSmart Subdivisions on SMUD's Distribution System, in, 2009, pp. Medium: ED; Size: 41 pp.
- [7] Y. Ueda, K. Kurokawa, T. Itou, K. Kitamura, K. Akanuma, M. Yokota, H. Sugihara, A. Morimoto, Advanced Analysis of Grid-Connected PV System's Performance and Effect of Batteries, *Electrical Engineering in Japan*, 164 (2008).
- [8] P. McNutt, J. Hambrick, M. Keese, Effects of photovoltaics on distribution system voltage regulation, in: *Photovoltaic Specialists Conference (PVSC)*, 2009 34th IEEE, 2009, pp. 001914-001917.
- [9] R. Tonkoski, L.A.C. Lopes, T.H.M. EL-Fouly, Droop-based Active Power Curtailment for Overvoltage Prevention in Grid Connected PV Inverters, in: *IEEE ISIE 2010 - IEEE International Symposium on Industrial Electronics*, Bari, 2010.
- [10] CSA, C22.2 No. 257-06 Interconnecting Inverter-based Micro-distributed Resources to Distribution Systems, in, 2006.
- [11] CSA, CAN3-C235-83 Preferred Voltage Levels for AC Systems, 0 to 50 000 V, in, R2006.
- [12] S. Conti, A. Greco, N. Messina, S. Raiti, Local voltage regulation in LV distribution networks with PV distributed generation, in: *Power Electronics, Electrical Drives, Automation and Motion*, 2006. *SPEEDAM 2006. International Symposium on*, 2006, pp. 519-524.
- [13] L. Yun Wei, K. Ching-Nan, An Accurate Power Control Strategy for Power-Electronics-Interfaced Distributed Generation Units Operating in a Low-Voltage Multibus Microgrid, *IEEE Transactions on Power Electronics*, 24 (2009) 2977-2988.
- [14] S. Papathanassiou, N. Hatzigiorgiou, K. Strunz, A Benchmark Low Voltage Microgrid Network., in: *Proceedings of the CIGRE Symposium: Power Systems with Dispersed Generation*, Athens, Greece, 2005.
- [15] E. Paraskevadaki, S. Papathanassiou, M. Papadopoulos, Benefits from DG Power Factor Regulation in LV Networks, in: *20th International Conference on Electricity Distribution (CIRED 2009)*, Prague, 2009.
- [16] J. Candanedo, A. Athienitis, A Systematic Approach for Energy Design of Advanced Solar Houses, in: *Electrical Power and Energy Conference 2009 - EPEC 09*, Montreal, 2009.
- [17] NorthWestern Energy, Residential Customer Profile, in, *NorthWestern Energy*, Butte, 2010.
- [18] CSA, C22.2 No. 107.1-01 General Use Power Supplies, in, 2001.
- [19] UL-1741 Inverters, Converters, Controllers and Interconnection System Equipment for Use with Distributed Energy Resources, in, *Underwriters Laboratories Inc.*, 2005.