

REALIZATION OF A CLASS OF SYMMETRICAL
LATTICE AND BRIDGED-T
TWO VARIABLE REACTANCE NETWORKS

by

HARNAM SINGH TREHIN

A MAJOR TECHNICAL REPORT

in

THE FACULTY

of

ENGINEERING

Presented in Partial Fulfilment of the Requirement
for the Degree of Master of Engineering

at

Concordia University

Sir George Williams Campus

Montreal, P.Q., Canada

MARCH 1977

Harnam Singh Trehin 1977

REALIZATION OF A CLASS OF SYMMETRICAL
LATTICE AND BRIDGED-T
TWO VARIABLE REACTANCE NETWORKS

HARNAM SINGH TREHIN

ABSTRACT

This report considers a class of two variable reactance networks of the type symmetrical lattice and bridged-T. In the case of symmetrical lattice it is shown that it is possible to have constant resistance symmetrical lattice in two variable provided the impedances are functions of both the variables. In the case of bridged-T networks it is not possible to have the constant resistance property in two variables. However, a special subclass of bridged-T-networks constitute a constant resistance network in single variable only when the other variable is made equal to unity.

*Dedicated to the memory
of my Father*

S. Swaran Singh Trehan

TABLE OF CONTENTS

	PAGE
ACKNOWLEDGEMENTS.	111
LIST OF FIGURES.	v
LIST OF TABLES.	v
 <u>PART</u>	
1 INTRODUCTION.	1
1.1 General.	1
1.2 Advantages of Mixed, Lumped, Distributed Structures.	1
1.3 Linear, Lumped, Finite, Bilateral Networks.	2
1.4 Mixed Lumped, Distributed Networks.	3
1.5 Definitions of Multivariable Reactance Functions	6
1.6 Some Similarities and Dissimilarities Between SRF's and MRF's:	8
1.7 Scope of the Report.	9
 2 TWO VARIABLE SYMMETRICAL LATTICE REACTANCE NETWORKS.	 10
2.1 Introduction.	10
2.2 Properties of Symmetrical Lattice in Two Variables.	10

2.3	Constant Resistance Symmetrical Lattice.	17
2.4	Synthesis of Symmetrical Lattice Where one Arm Contains One Element in P_1 Only and Other Arm Contains One Element in P_2 Only.	19
2.5	Synthesis of A Class of Two Variable Symmetrical Lattice	23
2.6	Example.	
2.7	Summary and Discussion	29
3	TWO VARIABLE BRIDGED-T REACTANCE NETWORKS.	30
3.1	Introduction	30
3.2	Properties of Bridged-T Network in Two Variables.	30
3.3	Properties of Bridged-T Networks of Type B_1 and B_2	36
3.4	Properties of Bridged-T Network Whose $Z_{11}(p_1, 1)$ and $Z_{11}(1, p_2)$ are Positive Real Numbers.	51
3.5	Properties of Bridged-T Networks Result- ing in Single Variable Constant Resistance Networks.	52
3.6	Examples.	57
3.7	Summary and Discussion.	60
4	CONCLUSION.	61
	REFERENCES.	63

ACKNOWLEDGEMENTS

The author wishes to record his appreciation and deep sense of gratitude to Dr. V. Ramachandran for suggesting the problem and his guidance throughout the course of this investigation.

The author is highly thankful to Dr. M. Vidyasagar for his valuable suggestions during the preparation of this report.

Montreal, P.Q.
March, 1977

Harnam Singh Trehin

LIST OF FIGURES

<u>FIGURE</u>		<u>PAGE</u>
1.4-1	Network Consisting of Resistors, Capacitors and Commensurate Lossless Transmission Lines.	5
1.4-2	Typical Sections for Two Variable Reactance Function.	5
2.1-1	A Symmetrical Lattice Network in Two Variables.	11
2.1-2	Possible Symmetrical Lattice Networks in Two Variables.	12
2.3-1	A Two Variable Symmetrical Lattice Terminating in a 1.0 Ω Load.	18
2.3-2	Two Variable Constant Resistance Symmetrical Lattice; terminating in one Ohm Load.	20
2.6-1	Constant Resistance Symmetrical Lattice in Two Variables of the Example Problem.	28
3.1-1	Typical Bridged-T Network in Two Variables.	31
3.5-1	Two Variable and Single Variable Constant Resistance Networks of the Example Problem 1.	58
3.5-2	Two Variable and Single Variable Constant Resistance Network of the Example Problem 2.	59

LIST OF TABLES

<u>TABLE</u>		<u>PAGE</u>
2.2-1	Z_{11} and Z_{12} of the Symmetrical Lattices of the Kind SL_1 , SL_2 , SL_3 and SL_4 in Two Variables (p_1, p_2) and in Single Variables $(1, p_2)$ and $(p_1, 1)$	14
2.5-1	Forms of the Reactance Functions in two Variables (p_1, p_2) and single variables $(1, p_2)$ and $(p_1, 1)$ for symmetrical lattice of the kind SL_1 , SL_2 , SL_3 and SL_4	26
3.1-1	Possible Existing Cases of Bridged-T-Networks in Two Variables.	34
3.2-1	Z_{11} , Z_{22} and Z_{12} of the Bridged-T Networks of the Kind B_1 and B_2 in Two Variables (p_1, p_2) and In Single Variable $(1, p_2)$ and $(p_1, 1)$	37
3.3-1	Possible Existing Symmetrical Bridged-T Networks In Two Variables and Corresponding Single Variable Constant Resistance Networks.	53

PART I

INTRODUCTION

1.1 GENERAL

Linear, lumped, finite, passive networks may be completely characterized by rational functions of the complex frequency variable s . A great deal of literature is available on the properties and realization of such network functions [1]. However, if we allow the network to include distributed elements as well as lumped elements, the network functions are in general no longer rational in s . Such mixed lumped-distributed structures are highly desirable as may be seen from the following discussion.

1.2 ADVANTAGES OF MIXED LUMPED-DISTRIBUTED STRUCTURES

The following are some of the advantages of mixed lumped distributed networks:

- (a) In the case of mixed lumped-distributed structure allowances may be made for the parasitics in the terminating impedance, i.e. the terminations need not be purely resistive.
- (b) A conventional quarter-wave transformer gives small or no attenuation at the higher harmonics. On the other hand, the mixed dis-

tributed impedance transformer can be designed to have the properties of an impedance transformer and a low pass filter. This property is useful where combined filtering and impedance transformation is desirable.

- (c) In the case of comb-line filter, lumped capacitive coupling at the input and output reduces the filter size by eliminating the transmission line matching section.
- (d) In the case of cascaded unit element filters, the number of UE's can be reduced from $(2n+1)$ to n , if the cascaded lines are separated by $(n+1)$ lumped capacitors.

1.3 LINEAR-LUMPED-FINITE-PASSIVE NETWORKS

The driving point immittance functions for networks consisting of lumped, linear, finite, passive, bilateral elements may be expressed as rational functions of the complex frequency variables, that is, they may be written as:

$$Z(s) = \frac{p(s)}{q(s)} = \frac{a_0 s^n + a_1 s^{n-1} + \dots + a_{n-1} s + a_n}{b_0 s^m + b_1 s^{m-1} + \dots + b_{m-1} s + b_m} \dots 1.2-1$$

and can be put in the form -

$$Z(s) = \frac{a_0}{b_0} \frac{(s - z_1)(s - z_2) \dots (s - z_n)}{(s - p_1)(s - p_2) \dots (s - p_m)} ; |m-n| \leq 1 \dots 1.2-2$$

where the z_n 's are the zeros and the p_m 's are the poles of $Z(s)$ and the coefficients a_i 's and b_i 's ($i = 0, 1, 2 \dots$) are positive real constants. It is also noted that both $p(s)$ and $q(s)$ are Hurwitz polynomials, i.e. they contain zeros only in the closed left half of s-plane.

On the other hand, we can also say that only positive real functions can be realized as a LLFP Networks.

1.4 MIXED LUMPED-DISTRIBUTED NETWORKS

However, as pointed out earlier, if the network consists of distributed elements as well as lumped elements, its driving point immittance need not be a rational function of s .

The realization methods available in the lumped network theory are not directly applicable in mixed distributed case due to the transcendental nature of the network functions.

Two different approaches are followed to solve the realization problem of these mixed lumped distributed networks. One of them directly deals with the transcendental functions which are termed as the single variable approach. In the other approach the transcendental functions of s are converted into polynomial functions of several variables p_i . This is called the multivariable approach. This is illustrated by the following example.

Let us consider the network shown in Fig. 1.4-A. This network consists of resistors, capacitors and commensurate lossless transmission lines (unit elements).

The chain matrix of a single unit element is of the form:

$$\begin{bmatrix} A & B \\ C & D \end{bmatrix} = \begin{bmatrix} \cosh s\tau & z_0 \sinh s\tau \\ \frac{1}{z_0} \sinh s\tau & \cosh s\tau \end{bmatrix} \dots \dots \dots 1.4-1$$

where τ and z_0 are constants.

Now the overall ABCD parameters of the network becomes:

$$\begin{bmatrix} A & B \\ C & D \end{bmatrix} = \begin{bmatrix} 1 & R_1 \\ 0 & 1 \end{bmatrix} \begin{bmatrix} \cosh s\tau & z_0 \sinh s\tau \\ \frac{1}{z_0} \sinh s\tau & \cosh s\tau \end{bmatrix} \begin{bmatrix} 1 & 0 \\ SC_1 & 1 \end{bmatrix} \begin{bmatrix} \cosh s\tau & z_0 \sinh s\tau \\ \frac{1}{z_0} \sinh s\tau & \cosh s\tau \end{bmatrix} \dots \dots \dots 1.4-2$$

$$\begin{bmatrix} 1 & 0 \\ SC_2 & 1 \end{bmatrix} \begin{bmatrix} 1 & 0 \\ \frac{1}{R_2} & 1 \end{bmatrix}$$

The input impedance at points x - x' is

$$Z_{in} = \frac{A}{C}$$

$$= \frac{1 \left\{ (1+s^2 \cdot \tanh^2 s\tau \cdot z_0^2 C_1^2 + 3z_0 C_1 \operatorname{stanh} s\tau + 2/R_2 \cdot z_0 \tanh s\tau) \right.}{(1-\tanh^2 s\tau)(z_0 C_1 s^2 \tanh s\tau + C_1 \operatorname{stanh}^2 s\tau + 2C_1 s + \frac{z_0 C_1}{R_2})}$$

$$+ \frac{C_1 z_0^2}{R_2} \cdot \tanh^2 s\tau + \tanh^2 s\tau + 1) + R_1 (z_0 C_1 s \tanh s\tau + C_1 \operatorname{stanh}^2 s\tau + 2C_1 s \operatorname{stanh} s\tau + 2/z_0 \tanh s\tau + 1/R_2 \tanh^2 s\tau + 1/R_2)$$

$$\left. + \frac{z_0 C_1}{R_2} \operatorname{stanh} s\tau + 2/z_0 \tanh s\tau + 1/R_2 \tanh^2 s\tau + 1/R_2 \right\} \dots \dots \dots 1.4-3$$

Now by defining

$$p_1 = s \text{ and } p_2 = \tanh s\tau \dots \dots \dots 1.4-4'$$

and substituting the new variables p₁ and p₂ in (1.4-2) we have --

$$\begin{bmatrix} A & B \\ C & D \end{bmatrix} = \begin{bmatrix} 1 & R_1 \\ 0 & 1 \end{bmatrix} \frac{1}{\sqrt{1-p_2^2}} \begin{bmatrix} 1 & z_0 p_2 \\ \frac{p_2}{z_0} & 1 \end{bmatrix} \begin{bmatrix} 1 & 0 \\ SC_1 & 1 \end{bmatrix} \frac{1}{\sqrt{1-p_2^2}} \begin{bmatrix} 1 & z_0 p_2 \\ \frac{p_2}{z_0} & 1 \end{bmatrix} \dots \dots \dots 1.4-5$$

$$\begin{bmatrix} 1 & 0 \\ SC_2 & 1 \end{bmatrix} \begin{bmatrix} 1 & 0 \\ 1/R_2 & 1 \end{bmatrix}$$

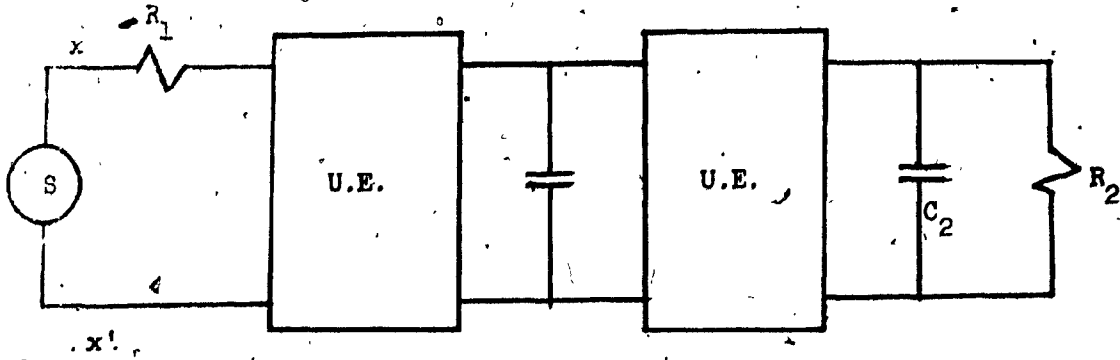

Fig. 1.4-1

Network consists of resistors, capacitors and commensurate lossless transmission lines.

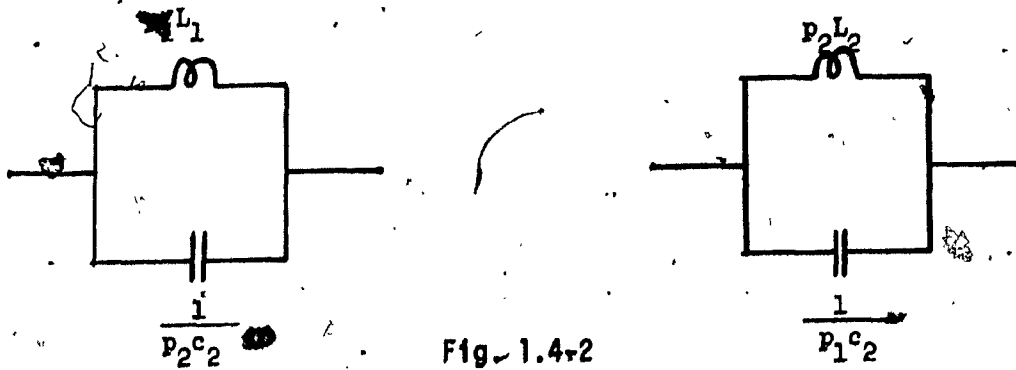

Fig. 1.4-2

Typical sections for two variable reactance function.

also (1.4-3) can be put in terms of new variables p_1 and p_2 as

$$Z_{in} = \frac{A}{C} = \frac{1}{1-p_2^2} \cdot \frac{X + R_1 Z}{Z} \dots \dots \dots] 1.4-6$$

The X and Z in 1.4-6 are given by

$$X = 1 + p_1^2 \cdot p_2^2 z_0^2 c_1^2 + 3z_0 c_1 p_1 p_2 + \frac{2}{R_2} \cdot z_0 p_2 + \frac{c_1 z_0^2}{R_2} p_2^2 + p_2^2 + 1 \dots \dots 1.4-7$$

and

$$Z = z_0 c_1^2 p_2 p_1^2 + c_1 p_2^2 p_1 + 2c_1 p_1 + \frac{z_0 c_1}{R_2} p_1 \cdot p_2 + \frac{2}{z_0} p_2 + \frac{1}{R_2} p_2^2 + \frac{1}{R_2} \dots \dots 1.4-8$$

We notice here that it has been possible to express the input impedance as a rational function of the two variables p_1 and p_2 . This approach may be extended to interconnections of non-commensurate transmission lines also.

Common examples of circuits containing both lumped and distributed elements are networks containing semiconductor elements and transmission lines or wave guides or indeed networks of transmission lines alone where lumped discontinuities inevitably occur.

1.5 DEFINITIONS

Some accepted definitions of multivariable network functions are given below [2].

Definition 1

A rational function $F(p_1, p_2, \dots, p_n)$ of n complex variables p_1, p_2, \dots, p_n is called a Multivariable Positive Real Function (MPRF) when the following conditions are satisfied:

- 1) $F(p_1, p_2, \dots, p_n)$ is a real function of p_1, p_2, \dots, p_n

and

$$1) \operatorname{Re} F(p_1, p_2, \dots, p_n) \geq 0 \text{ in the polydomain } \operatorname{Re} p_i \geq 0$$

where $i = 1, 2, \dots, n$

Definition 2

A rational function $F(p_1, p_2, \dots, p_n)$ is called a Multivariable Reactance Function (MRF) when the following conditions are satisfied:

1) $F(p_1, p_2, \dots, p_n)$ is an MPRF

and

$$1) F(p_1, p_2, \dots, p_n) = -F(-p_1, -p_2, \dots, -p_n)$$

Definition 3

A polynomial of n -complex variables p_1, p_2, \dots, p_n is called a multivariable Hurwitz polynomial in the narrow sense (MHPN) if it has no zeros in the regions:

$$\operatorname{Re} p_1 > 0, \dots, \operatorname{Re} p_{i-1} > 0, \operatorname{Re} p_i \geq 0, \operatorname{Re} p_{i+1} > 0, \dots, \operatorname{Re} p_n > 0,$$

for all $i (1 \leq i \leq n)$

Definition 4

A polynomial of n -complex variables p_1, p_2, \dots, p_n is called Multivariable Hurwitz Polynomial in the broad sense (MHPB) if it has no zeros in the open polydomain $\operatorname{Re} p_i > 0$, and if those zeros for $\operatorname{Re} p_i = 0$ are simple.

1.6. SOME SIMILARITIES AND DISSIMILARITIES BETWEEN SRF'S AND MRF'S [3]

In Section 1.5 some definitions of multivariable reactance functions has been given. We observe the following similarities and dissimilarities between the above definitions and the definition of a single variable reactance conversion and these have been very well discussed. [3]

In particular it can easily be seen that these definitions are analogous to the definitions of similar functions in the single variable case. Hence, these definitions can be considered as logical extensions of those in the single variable case.

It is also known that a reactance function of a single variable (SRF) can always be synthesized using a minimum number of elements. This number is equal to the order of the function. These different canonic structures are due to Foster [1], Cauer [1], Lee [1, 5], Kida [6], Ramachandran and Swamy [7]. This however, may not be true in the case of two variable reactance functions (TRF).

In general, the two variable reactance functions require either ideal transformers or passive ideal gyrators for their realization [8, 9]. However, some work has been done regarding the realizations of some classes of TRF's without transformers or gyrators [2, 10, 11].

It has been shown that there exist a class of TRF's which can be decomposed into a sum of two single variable reactance functions [12, 13, 14, 15]. Specifically, conditions have been obtained to decompose $Z(p_1, p_2)$ as the sum of $Z_1(p_1)$ and $Z_2(p_2)$ where $Z_1(p_1)$ is a single variable reactance function in p_1 and $Z_2(p_2)$ is a single variable reactance function in p_2 .

Each function can be realized by the known methods of a single variable reactance function.

Also necessary and sufficient conditions have been obtained for the realization of TRF's in a form similar to the Foster form consisting of one element of variable p_1 (an inductor or a capacitor), and the other element of variable p_2 (a capacitor or inductor) [10], and a typical section is as shown in Fig. 1.2. For this type of realization, it is shown that if the Foster form exists, other forms similar to the single variable canonic structures exist. In addition, it is also known that if one form exists, the other form need not exist [16]. Hence, in the case of two-variable reactance functions, it is worthwhile to consider specific structures and their properties.

1.7 SCOPE OF THE REPORT

This report studies the cases of two variable symmetrical lattice and bridged-T network structures. These structures have not been examined in the literature so far to the author's knowledge. Part II discusses symmetrical lattice in two variables. Part III discusses Bridged-T networks, and Part IV discusses the conclusion arising from this report.

PART II

TWO VARIABLE SYMMETRICAL LATTICE REACTANCE NETWORKS

2.1 INTRODUCTION

As stated earlier, we shall consider two variable symmetrical lattice reactance networks in this chapter. Fig. 2.1-1 shows a symmetrical lattice network where the branch impedances z_a and z_b are reactance functions of p_1 and p_2 . First, we shall consider that any impedance contains one element of one variable only. The two possibilities arising out of the above constraint is shown in Fig. 2.1-2.

2.2 PROPERTIES OF SYMMETRICAL LATTICE IN TWO VARIABLES

Here the properties of the symmetrical lattice will be examined. For the network shown in Fig. 2.1-1, the open circuit impedance functions are:

$$Z_{11}(p_1, p_2) = Z_{22}(p_1, p_2) = \frac{1}{2}(z_a + z_b) \dots \dots \dots 2.2-1$$

and

$$Z_{12}(p_1, p_2) = \frac{1}{2}(z_b - z_a) \dots \dots \dots 2.2-2$$

Also, the short circuit admittance functions are:

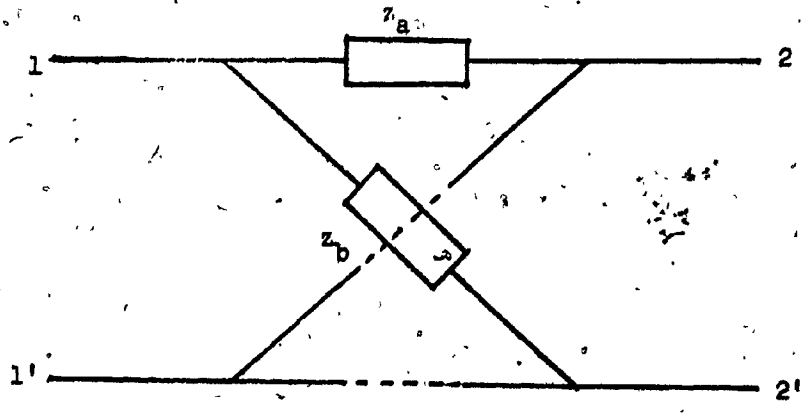

Fig. 2.1-1

A Symmetrical Lattice Network
(The impedances z_a and z_b are reactance functions of either p_1 or p_2)

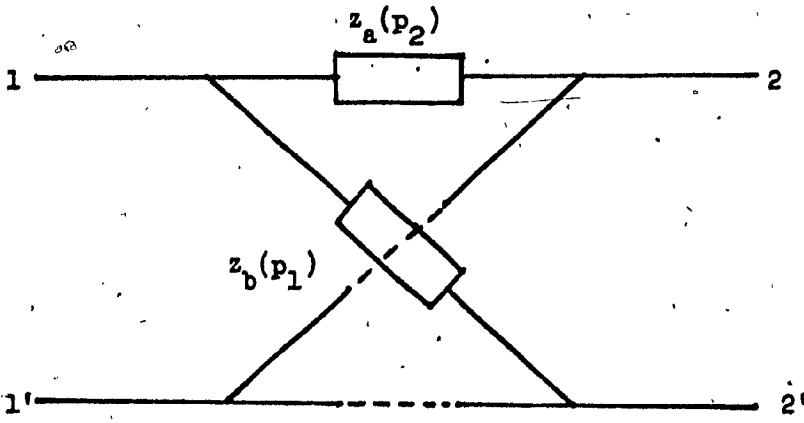
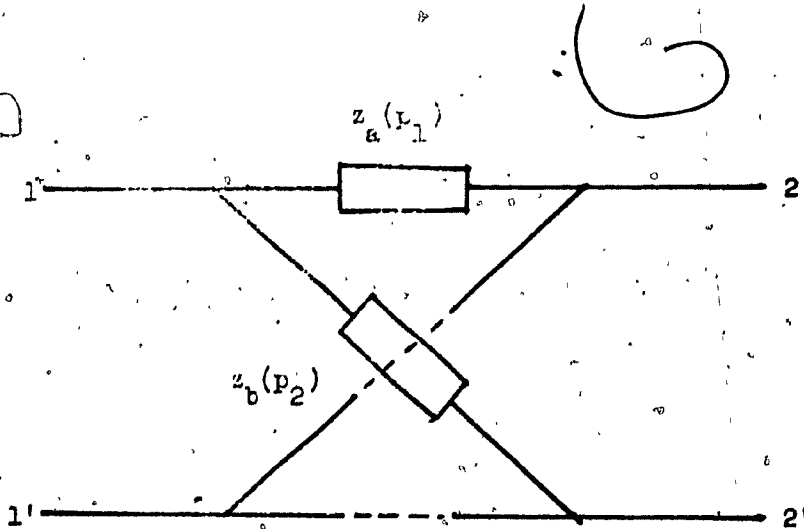

Fig. 2.1-2

Symmetrical Lattice in Two Variables - when each impedance is the function one variable.

$$Y_{11}(p_1, p_2) = Y_{22}(p_1, p_2) = \frac{1}{2z_a \cdot z_b} (z_a + z_b) \dots \dots \dots 2.2-3$$

$$Y_{12}(p_1, p_2) = \frac{1}{2z_a \cdot z_b} (z_a - z_b) \dots \dots \dots 2.2-4$$

The different possibilities of z_a and z_b containing one element of one variable only, and the corresponding Z parameters with structures are shown in Table 2.2-I.

In these networks if we put $p_1 = 1$ or $p_2 = 1$ there result a general RL or RC network in a single variable either in p_1 or p_2 . However, after putting $p_1 = 1$ (or $p_2 = 1$) and considering only one type of reactive element in the other variable (say only capacitance or inductance) there result two element kind network functions.

Utilizing the technique of putting one of the variables equal to unity at a time and examining the properties of the resulting networks, we can classify the above networks (shown in Table 2.2-I) as follows:

1) Type SL_1 : The network consisting of p_1 type capacitors and p_2 type inductors. In this category if we put $p_1 = 1$ the resulting network is RL type whereas if $p_2 = 1$ the resulting network is Rc type.

11) Type SL_2 : The network consisting of p_1 type inductors and p_2 type capacitors. In this category if $p_1 = 1$ the resulting network is Rc type and if $p_2 = 1$ the resulting network is of RL type.

	$Z_{11}(p_1, p_2) = Z_{22}(p_1, p_2)$ $= \frac{1}{2} \left\{ \frac{1 + c_1 L_1 p_1}{c_1 p_2} \right\}$ $Z_{12}(p_1, p_2) = \frac{1}{2} \left\{ \frac{c_1 L_1 p_1 - 1}{c_1 p_2} \right\}$	$Z_{11}(p_1, 1) = Z_{22}(p_1, 1)$ $= \frac{1}{2} \left[\frac{1 + c_1 L_1 p_1}{c_1} \right]$ $Z_{12}(p_1, 1) = \frac{1}{2} \left[\frac{c_1 L_1 p_1 - 1}{c_1} \right]$
	$Z_{11}(p_1, p_2) = Z_{22}(p_1, p_2)$ $= \frac{1}{2} \left\{ \frac{c_2 L_2 p_2 + 1}{c_2 p_1} \right\}$ $Z_{12}(p_1, p_2) = \frac{1}{2} \left\{ \frac{1 - c_2 L_2 p_2}{c_2 p_1} \right\}$	$Z_{11}(p_1, 1) = Z_{22}(p_1, 1)$ $= \frac{1}{2} \left[\frac{c_2 L_2 p_2 + 1}{c_2} \right]$ $Z_{12}(p_1, 1) = \frac{1}{2} \left[\frac{1 - c_2 L_2 p_2}{c_2} \right]$

Table 2.2-1 -- Symmetrical Lattice Structures of the Kind SL₁, SL₂, SL₃ and SL₄ with Z₁₁ and Z₁₂ in two variables (p₁, p₂) and one variable (p₁, p₂) and (p₁, 1).



$$Z_{11}(p_1, p_2) = Z_{22}(p_1, p_2)$$

$$= \frac{1}{2} \left\{ \frac{1 + c_1 L_1 p_1 p_2}{c_1 p_1} \right\}$$

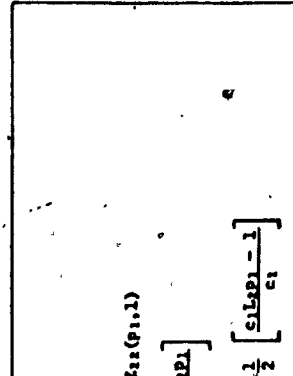
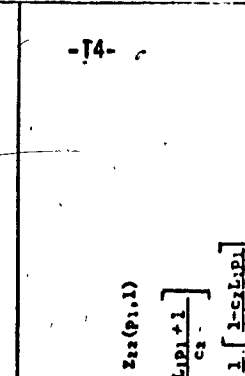
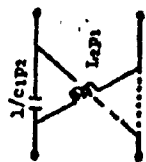
$$Z_{12}(p_1, p_2) = \frac{1}{2} \left\{ \frac{c_1 L_1 p_1 p_2 - 1}{c_1 p_1} \right\}$$

$$Z_{11}(1, p_2) = Z_{22}(1, p_2)$$

$$= \frac{1}{2} \left[\frac{1 + c_1 L_1 p_2}{c_1} \right]$$

$$Z_{12}(1, p_2) = \frac{1}{2} \left[\frac{c_1 L_1 p_2 - 1}{c_1} \right]$$

$$Z_{11}(p_1, 1) = Z_{22}(p_1, 1)$$

$$= \frac{1}{2} \left\{ \frac{1 + c_1 L_1 p_1}{c_1 p_1} \right\}$$

$$Z_{12}(p_1, 1) = \frac{1}{2} \left\{ \frac{c_1 L_1 p_1 - 1}{c_1 p_1} \right\}$$

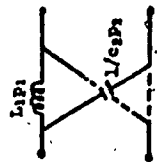

$$Z_{11}(p_1, p_2) = Z_{22}(p_1, p_2)$$

$$= \frac{1}{2} \left\{ \frac{1 + c_1 L_1 p_1 p_2}{c_1 p_1} \right\}$$

$$Z_{12}(p_1, p_2) = \frac{1}{2} \left\{ \frac{1 - c_1 L_1 p_1 p_2}{c_1 p_1} \right\}$$

$$Z_{11}(1, p_2) = Z_{22}(1, p_2)$$

$$= \frac{1}{2} \left\{ \frac{1 + c_1 L_1 p_2}{c_1} \right\}$$

$$Z_{12}(1, p_2) = \frac{1}{2} \left\{ \frac{1 - c_1 L_1 p_2}{c_1} \right\}$$

$$Z_{11}(p_1, 1) = Z_{22}(p_1, 1)$$

$$= \frac{1}{2} \left[\frac{1 + c_1 L_1 p_1}{c_1 p_1} \right]$$

$$Z_{12}(p_1, 1) = \frac{1}{2} \left[\frac{1 - c_1 L_1 p_1}{c_1 p_1} \right]$$

Table 2.2-1 Cont'd -- Z_{11} and Z_{12} of the Symmetrical Bridged-T of Type SL_2 .

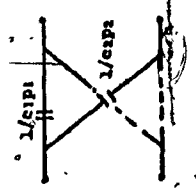

$$Z_{11}(p_1, p_2) = Z_{11}(p_1, p_2) = \frac{1}{2} \left\{ \frac{c_1 p_1 + c_2 p_2}{c_1 c_2 p_1 p_2} \right\}$$

$$Z_{12}(p_1, p_2) = \frac{1}{2} \left\{ \frac{c_1 p_1 - c_2 p_2}{c_1 c_2 p_1 p_2} \right\}$$

$$Z_{11}(1, p_2) = Z_{11}(1, p_2) = \frac{1}{2} \left\{ \frac{c_1 + c_2 p_2}{c_1 c_2 p_2} \right\}$$

$$Z_{12}(1, p_2) = \frac{1}{2} \left\{ \frac{c_1 - c_2 p_2}{c_1 c_2 p_2} \right\}$$

$$Z_{11}(p_1, 1) = Z_{11}(p_1, 1) = \frac{1}{2} \left\{ \frac{c_1 p_1 + c_2}{c_1 c_2 p_1} \right\}$$

$$Z_{12}(p_1, 1) = \frac{1}{2} \left\{ \frac{c_1 p_1 - c_2}{c_1 c_2 p_1} \right\}$$

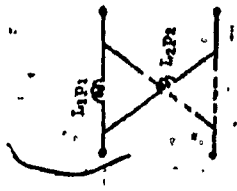

$$Z_{11}(p_1, p_2) = Z_{11}(p_1, p_2) = \frac{1}{2} \left\{ L_1 p_1 + L_2 p_2 \right\}$$

$$Z_{12}(p_1, p_2) = \frac{1}{2} \left\{ L_2 p_2 - L_1 p_1 \right\}$$

$$Z_{11}(1, p_2) = Z_{11}(1, p_2) = \frac{1}{2} \left[L_1 + L_2 p_2 \right]$$

$$Z_{12}(1, p_2) = \frac{1}{2} \left[L_2 p_2 - L_1 \right]$$

$$Z_{11}(p_1, 1) = Z_{11}(p_1, 1) = \frac{1}{2} \left[L_1 p_1 + L_2 \right]$$

$$Z_{12}(p_1, 1) = \frac{1}{2} \left[L_2 - L_1 p_1 \right]$$

Table 2.2-1 Cont'd.

iii) Type SL_3 : The network consisting of capacitors of the type p_1 and p_2 . In this category if $p_1 = 1$ or $p_2 = 1$ the resulting network is RC type.

iv) Type SL_4 : The network consisting of inductors of the type p_1 and p_2 . In this category if $p_1 = 1$ or $p_2 = 1$, the resulting network is of the RL type.

As already noted, these four types of networks with their Z parameters are shown in Table 2.2-I. Some general properties of the above symmetrical lattice networks can be observed:

- i) The poles of z matrix (y-matrix) with p_1 or $p_2 = 1$ shall be simple and lie on the -ve real axis of the variable p_2 or p_1 respectively.
- ii) The zeros of z_{11} and z_{22} (y_{11} and y_{22}) with p_1 or $p_2 = 1$ shall be simple and lie on the -ve real axis of the variable p_2 or p_1 respectively.
- iii) None of these networks with $p_1 = 1$ or $p_2 = 1$ can give a constant resistance network in the single variable.

2.3 CONSTANT RESISTANCE SYMMETRICAL LATTICE

Till now we have discussed the lattice network without any termination. In this section we shall study the symmetrical lattice terminated in a one ohm (1.0Ω) load as shown in Fig. 2.3-1.

We know from analysis that the input impedance is equal to one ohm (1.0Ω) if -

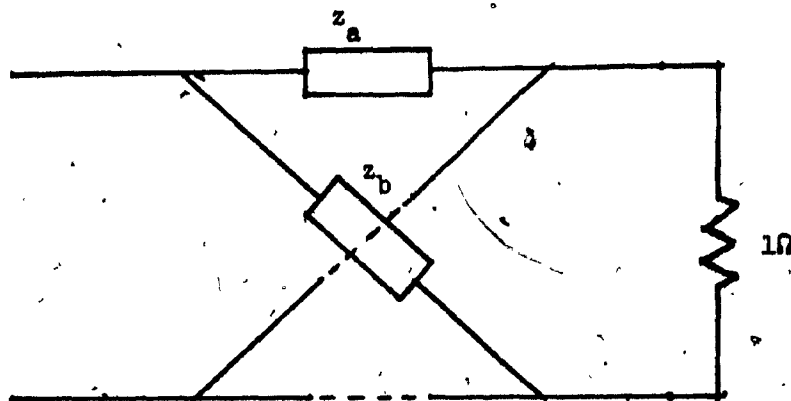

Fig. 2.3-1

Two Variable Symmetrical Lattice Terminating in One Ohm Load.

$$z_a \cdot z_b = 1 \dots \dots \dots 2.3-1$$

If $z_a = f(p_1)$ and $z_b = g(p_2)$ the above condition cannot be satisfied. This means that the existence of a constant-resistance symmetrical lattice in two variables is not possible, when any branch impedance is a function of one of the variables only, while the other branch is a function of the other variable only. However, constant resistance symmetrical lattice network is possible when any branch impedance is a function of both variables, as can be seen from the example.

Example - If

$$z_a = \frac{1}{\alpha_1 p_1 + \alpha_2 p_2} \dots \dots \dots 2.3-2$$

and

$$z_b = (\alpha_1 p_1 + \alpha_2 p_2) \dots \dots \dots 2.3-3$$

The corresponding network is shown in Fig. 2.3-2. Since there are a large number of networks possible no attempt is made to exhaust all possibilities.

2.4 SYNTHESIS OF A SYMMETRICAL LATTICE WHERE ONE ARM CONTAINS ONE ELEMENT IN p_1 ONLY AND OTHER ARM CONTAINS ONE ELEMENT IN p_2 ONLY

The foregoing discussion enables us to obtain the conditions under which a symmetrical lattice network can be synthesized.

Putting $p_1 = 1$ or $p_2 = 1$ the following shall be satisfied:

Type SL_1 : The conditions to be satisfied are:

- 1) $Z_{11}(p_1, 1)$ is $Z_{RC}(p_1)$ of the form

$$Z_{11}(p_1, 1) = \frac{K_0}{p_1} + K_\infty$$

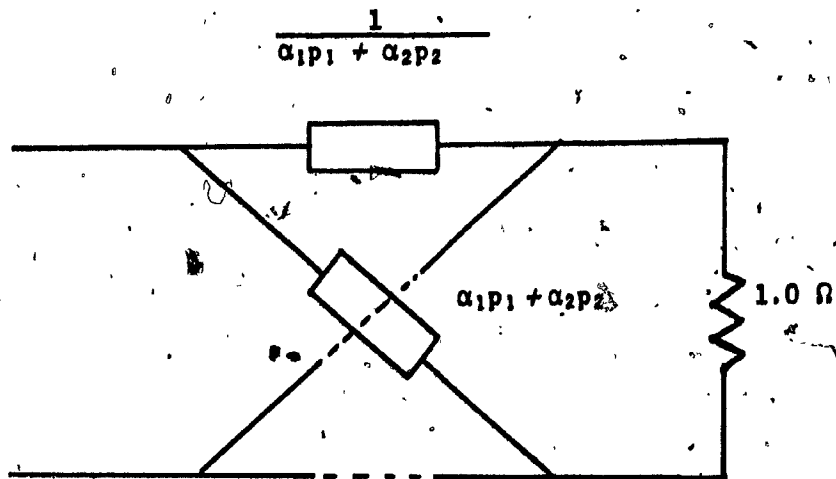

Fig. 2.3-2

Two Variable Constant Resistance Symmetrical Lattice;
terminating in One Ohm Load.

ii) $Z_{11}(1, p_2)$ is $Z_{RL}(p_2)$ of the form

$$Z_{11}(1, p_1) = k_0 + k_\infty p$$

and the poles and zeros of $Z_{11}(p_1, 1)$ and $Z_{11}(1, p_2)$ shall be the same.

iii) $Z_{12}(p_1, 1)$ shall have zeros of transmission on the positive real axis and these shall be the same as the zeros of $Z_{12}(1, p_2)$.

Type SL_2 : The conditions are:

i) $Z_{11}(p_1, 1)$ is $Z_{RL}(p_1)$ of the form

$$Z_{11}(p_1, 1) = k_0 + k_\infty p_1$$

ii) $Z_{11}(1, p_2)$ is $Z_{RC}(p_2)$ of the form

$$Z_{11}(1, p_2) = \frac{k_0}{p_2} + k_\infty$$

and the poles and zeros of $Z_{11}(p_1, 1)$ and $Z_{11}(1, p_2)$ shall be the same.

iii) $Z_{12}(p_1, 1)$ shall have zeros of transmission on the positive real axis and these shall be the same as the zeros of $Z_{12}(1, p_2)$.

Type SL_3 : i) $Z_{11}(p_1, 1)$ is $Z_{RC}(p_1)$ of the form

$$Z_{11}(p_1, 1) = \frac{k_{10}}{p} + k_{20}$$

ii) $Z_{11}(1, p_2)$ is $Z_{RC}(p_2)$ of the form

$$Z_{11}(1, p_2) = k_{10} + k_{20}/p_2$$

iii) $Z_{12}(p_1, 1)$ shall have zeros of transmission on the positive real axis on p_1 plane.

iv) $Z_{12}(1, p_2)$ shall have zeros of transmission on the positive real axis on p_2 plane and shall be the reciprocal of the zeros of $Z_{12}(p_1, 1)$

Type SL₄: The conditions for this type of network is as follows:

i) $Z_{11}(p_1, 1)$ is $Z_{RL}(p_1)$ of the form

$$Z_{11}(p_1, 1) = K_{1\infty} p_1 + k_{2\infty}$$

ii) $Z_{11}(1, p_2)$ is $Z_{RL}(p_2)$ of the form

$$Z_{11}(1, p_2) = K_{1\infty} + K_{2\infty} p_2$$

iii) $Z_{12}(p_1, 1)$ shall have zeros of transmission on the positive real axis on the p_1 plane.

iv) $Z_{12}(1, p_2)$ shall also have zeros of transmission on the positive real axis on the p_2 plane and shall be the reciprocal of the zeros of $Z_{12}(p_1, 1)$.

Hence when the specifications are given to realize $Z_{11}(p_1, p_2)$ and $Z_{12}(p_1, p_2)$ which satisfies any one set of the conditions given in types SL₁, SL₂, SL₃ and SL₄, they can be synthesized using single variable techniques [1], and replacing the resistance by inductance or capacitance as given below:

Type SL₁: 1) If $Z_{11}(p_1, 1)$ is made use of, R is replaced by the inductance in p_2 .

ii) If $Z_{11}(1, p_2)$ is made use of, R is replaced by the capacitance in p_1 plane.

Type SL₂: 1) If $Z_{11}(p_1, 1)$ is made use of, R is replaced by capacitance in p_2 plane.

ii) If $Z_{11}(1, p_2)$ is made use of, R is replaced by the inductance in p_1 plane.

Type SL₃: 1) If $Z_{11}(1, p_2)$ or $Z_{11}(p_1, 1)$ is made use of, R is replaced by capacitance in p_1 or p_2 plane respectively.

Type SL₄: 1) If $Z_{11}(1, p_2)$ or $Z_{11}(p_1, 1)$ is made use of, R is replaced by inductance in p_1 or p_2 plane respectively.

2.5 SYNTHESIS OF A CLASS OF TWO-VARIABLE SYMMETRICAL LATTICE

From the foregoing discussion, it can be observed that a class of two variable symmetrical lattice can also be realized following the same technique. The conditions are as given below:

Type SL₁: The conditions to be satisfied are:

i) $Z_{11}(p_1, 1)$ is $Z_{RC}(p_1)$ of the form

$$Z_{11}(p_1, 1) = K_{\infty} + \sum \frac{K_1}{p_1 + \sigma_1} + \frac{K_0}{p_1} \dots \dots \dots 2.5-1$$

ii) $Z_{11}(1, p_2)$ is $Z_{RL}(p_2)$ of the form

$$Z_{11}(1, p_2) = K_{\infty} p_2 + \sum \frac{K_1 p_2}{p_2 + \sigma_1} + K_0 \dots \dots \dots 2.5-2$$

The poles and zeros of $Z_{11}(p_1, 1)$ and $Z_{11}(1, p_2)$ shall be the same.

iii) $Z_{12}(p_1, 1)$ expanded in partial fraction shall have the same residue as the residue of $Z_{12}(1, p_2)$, i.e.

$$Z_{12}(p_1, 1) = \sum \frac{\alpha_j}{p_1 + \sigma_j} - \sum \frac{\beta_k}{p_1 + \sigma_k} \pm \alpha_{\infty} \pm \frac{\alpha_0}{p_1} \dots \dots \dots 2.5-3$$

and

$$Z_{12}(1, p_2) = \sum \frac{\alpha_j p_2}{p_2 + \sigma_j} - \sum \frac{\beta_k p_2}{p_2 + \sigma_k} \pm \alpha_{\infty} p_2 \pm \alpha_0 \dots \dots \dots 2.5-4$$

TYPE SL₂: The conditions are:

i) $Z_{11}(p_1, 1)$ is $Z_{RL}(p_1)$ of the form

$$Z_{11}(p_1, 1) = K_{\infty} p_1 + \sum \frac{K_1 p_1}{p_1 + \sigma_1} + K_0 \dots \dots \dots 2.5-5$$

ii) $Z_{11}(1, p_2)$ is $Z_{RC}(p_2)$ of the form

$$Z_{11}(1, p_2) = K_{\infty} + \sum \frac{k_1}{p_2 + \sigma_1} + \frac{k_0}{p_2} \dots \dots \dots 2.5-6$$

And the poles and zeros of $Z_{11}(p_1, 1)$ and $Z_{11}(1, p_2)$ shall be the same.

iii) $Z_{12}(p_1, 1)$ expanded in partial fraction expansion shall have the same residues as the residues of $Z_{12}(1, p_2)$, i.e.

$$Z_{12}(p_1, 1) = \sum \frac{\alpha_j p_1}{p_1 + \sigma_j} - \sum \frac{\beta_k p_1}{p_1 + \sigma_k} \pm \alpha_{\infty} p_1 \pm \alpha_0 \dots \dots \dots 2.5-7$$

and:

$$Z_{12}(1, p_2) = \sum \frac{\alpha_j}{p_2 + \sigma_j} - \sum \frac{\beta_k}{p_2 + \sigma_k} \pm \alpha_{\infty} \pm \frac{\alpha_0}{p_2} \dots \dots \dots 2.5-8$$

TYPE SL₃: The conditions are:

i) $Z_{11}(p_1, 1)$ is $Z_{RC}(p_1)$ of the form:

$$Z_{11}(p_1, 1) = \frac{K_{10}}{p_1} + \sum \frac{K_1}{p_1 + \sigma_1} + K_{20} \dots \dots \dots 2.5-9$$

ii) $Z_{11}(1, p_2)$ is also $Z_{RC}(p_2)$ of the form

$$Z_{11}(1, p_2) = K_{10} + \sum \frac{K_1}{p_2 + \sigma_1} + \frac{K_{20}}{p_2} \dots \dots \dots 2.5-10$$

iii) $Z_{12}(p_1, 1)$ expanded in partial fraction expansion shall have the same residues as the residues of $Z_{12}(1, p_2)$, i.e.

$$Z_{12}(p_1, 1) = \pm \alpha_{20} \pm \frac{\alpha_{10}}{p_1} + \sum \frac{\alpha_j}{p_2 + \sigma_j} - \sum \frac{v_k}{p_1 + \sigma_k} \dots \dots \dots 2.5-11$$

and

$$Z_{12}(1, p_2) = \pm \frac{\alpha_{20}}{p_2} \pm \alpha_{10} + \sum \frac{\alpha_j}{p_2 + \sigma_j} - \sum \frac{v_k}{p_1 + \sigma_k} \dots \dots \dots 2.5-11$$

shall be the reciprocal of the zeros of $Z_{12}(p, 1)$.

TYPE SL₄: The condition for this type of network is as follows:

i) $Z_{11}(p_1, 1)$ is $Z_{RL}(p_1)$ of the form

$$Z_{11}(p_1, 1) = K_{\infty} p_1 + \sum \frac{k_1 p_1}{p_1 + \sigma_1} + K_{2\infty} \dots \dots \dots 2.5-12$$

ii) $Z_{11}(1, p_2)$ is $Z_{RL}(p_2)$ of the form

$$Z_{11}(1, p_2) = k_{\infty} + \sum \frac{k_1 p_2}{p_2 + \sigma_1} + K_{2\infty} p_2 \dots \dots \dots 2.5-13$$

iii) $Z_{12}(p_1, 1)$ expanded in partial fraction expansion shall have the same residues as the residues of $Z_{12}(1, p_2)$, i.e.

KIND OF NETWORK CLASS	FORMS OF REACTANCE FUNCTIONS IN TWO VARIABLES (P ₁ , P ₂)	FORMS OF REACTANCE FUNCTION IN VARIABLE P ₁	FORMS OF REACTANCE FUNCTION IN VARIABLE P ₂
SL ₁	$Z_{11}(p_1, p_2) = K_0 p_2 + \sum \frac{K_1 p_2}{p_1 p_2 + \sigma_1} + \frac{K_2}{p_1}$ and $Z_{12}(p_1, p_2) = \sum \frac{a_1 p_2}{p_1 p_2 + \sigma_j} - \sum \frac{b_k p_2}{p_1 p_2 + \sigma_k} + a_0 p_2 + \frac{a_1}{p_1}$	$Z_{11}(p_1, 1) = K_0 + \sum \frac{K_1}{p_1 + \sigma_1} + \frac{K_2}{p_1}$ and $Z_{12}(p_1, 1) = \sum \frac{a_1}{p_1 + \sigma_j} - \sum \frac{b_k}{p_1 + \sigma_k} + a_0 + \frac{a_1}{p_1}$	$Z_{11}(1, p_2) = K_0 p_2 + \sum \frac{K_1 p_2}{p_2 + \sigma_1} + K_2$ and $Z_{12}(1, p_2) = \sum \frac{a_1 p_2}{p_2 + \sigma_j} - \sum \frac{b_k p_2}{p_2 + \sigma_k} + a_0 p_2 + a_1$
SL ₂	$Z_{11}(p_1, p_2) = K_0 p_1 \sum \frac{K_1 p_1}{p_1 p_2 + \sigma_1} + \frac{K_2}{p_2}$ and $Z_{12}(p_1, p_2) = \sum \frac{a_1 p_1}{p_1 p_2 + \sigma_1} - \sum \frac{b_k p_1}{p_1 p_2 + \sigma_k} + a_0 p_1 + \frac{a_1}{p_1}$	$Z_{11}(p_1, 1) = K_0 \sum \frac{K_1 p_1}{p_1 + \sigma_1} + K_2$ and $Z_{12}(p_1, 1) = \sum \frac{a_1 p_1}{p_1 + \sigma_1} - \sum \frac{b_k p_1}{p_1 + \sigma_k} + a_0 p_1 + a_1$	$Z_{11}(1, p_2) = K_0 \sum \frac{K_1}{p_1 + \sigma_1} + \frac{K_2}{p_2}$ and $Z_{12}(1, p_2) = \sum \frac{a_1}{p_1 + \sigma_1} - \sum \frac{b_k}{p_1 + \sigma_k} + a_0 + \frac{a_1}{p_1}$
SL ₃	$Z_{11}(p_1, p_2) = \frac{K_1 0}{p_1} + \sum \frac{K_1}{p_1 p_2 + \sigma_j} + \frac{K_2 0}{p_2}$ and $Z_{12}(p_1, p_2) = \frac{a_1 0}{p_1} - \frac{a_1 0}{p_1} + \sum \frac{a_1}{p_1 p_2 + \sigma_j}$	$Z_{11}(p_1, 1) = \frac{K_1 0}{p_1} + \sum \frac{K_1}{p_1 + \sigma_j} + K_2 0$ and $Z_{12}(p_1, 1) = a_1 0 - \frac{a_1 0}{p_1} + \sum \frac{a_1}{p_1 + \sigma_j}$	$Z_{11}(1, p_2) = \sum \frac{K_1}{p_2 + \sigma_j} + \frac{K_2 0}{p_2}$ and $Z_{12}(1, p_2) = a_1 0 - a_1 0 + \sum \frac{a_1}{p_2 + \sigma_j}$
SL ₄	$Z_{11}(p_1, p_2) = K_0 p_1 + \sum \frac{K_1 p_1 p_2}{p_1 p_2 + \sigma_1} + K_2 p_2$ and $Z_{12}(p_1, p_2) = a_0 p_1 - a_1 p_1 + \sum \frac{a_1 p_1 p_2}{p_1 p_2 + \sigma_j}$	$Z_{11}(p_1, 1) = K_0 p_1 + \sum \frac{K_1 p_1}{p_1 + \sigma_1} + K_2 p_1$ and $Z_{12}(p_1, 1) = a_0 p_1 - a_1 p_1 + \sum \frac{a_1 p_1}{p_1 + \sigma_j}$	$Z_{11}(1, p_2) = K_0 p_2 + \sum \frac{K_1 p_2}{p_2 + \sigma_1} + K_2 p_2$ and $Z_{12}(1, p_2) = a_0 p_2 - a_1 p_2 + \sum \frac{a_1 p_2}{p_2 + \sigma_j}$

TABLE 2.5-1 — Forms of the Reactance Functions in two Variables (P₁, P₂) and Single Variables (P₁, 1) and (1, P₂) for symmetrical lattice of the kind SL₁, SL₂, SL₃ and SL₄.

$$Z_{12}(p_1, 1) = \alpha_{2\infty} - \alpha_{1\infty} p_1 + \sum \frac{\alpha_j p_1}{p_1 + \sigma_j} \dots \dots \dots 2.5-14$$

and

$$Z_{12}(1, p_2) = \alpha_{2\infty} p_2 - \alpha_{1\infty} + \sum \frac{\alpha_j p_2}{p_2 + \sigma_j} \dots \dots \dots 2.5-15$$

The forms of Z_{11} and Z_{12} are given in Table 2.5-I.

In all the above cases, we can determine Z_b and Z_a by (2.2-1) and (2.2-2) with the condition that Z_{12} is realizable within a multiplicative constant which is determined by making Z_b and Z_a physically realizable. It should also be noted that types SL_1 and SL_2 can realize constant-resistance networks. Types SL_3 and SL_4 cannot realize constant resistance networks.

Example:

$$Z_{11}(p, p) = \left[\frac{1 + 32p_1^2 p_2^2 + 4p_1^4 + 8p_1 p_2 + 16p_1^3 p_2 + 5p_1^2 + 8p_1^2 p_2}{2p_1 + 8p_1^2 p_2 + 4p_1^4 + 8p_1 p_2 + 32p_1^2 p_2 + 16p_1^3 p_2} \right]$$

and

$$Z_{12}(p, p) = \left[\frac{-(1 + 4p_1^4 + 8p_1 p_2 + 16p_1^3 p_2 + 3p_1^2 - 8 p_1^2 p_2)}{2p_1 + 8p_1^2 p_2 + 4p_1^4 + 8p_1 p_2 + 32p_1^2 p_2 + 16p_1^3 p_2} \right]$$

using synthesis technique developed earlier we get the network as shown in Fig. 2.6-1.

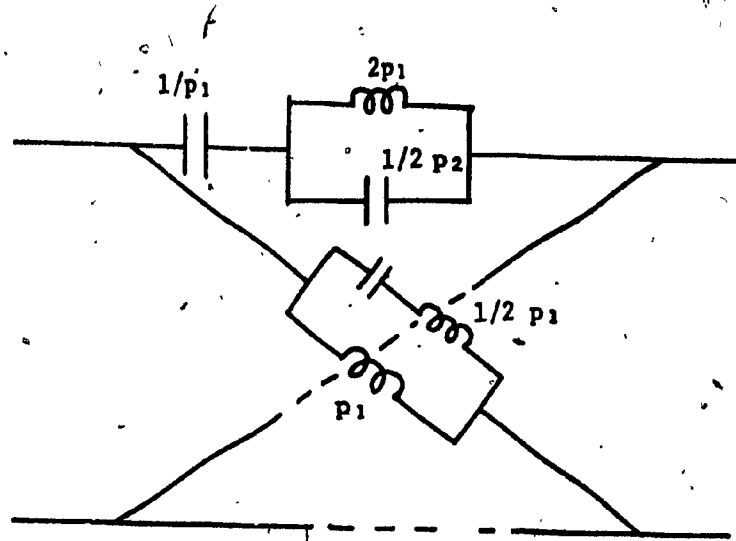

Fig. 2.6-1

Constant Resistance Symmetrical of the Example Problem.

2.7 SUMMARY AND DISCUSSIONS

From the study of symmetrical lattice in two variables it can easily be concluded that when z_a and z_b are functions of one variable only, it cannot constitute a constant resistance network. However, if they are functions of both variables, it can constitute a constant resistance symmetrical lattice.

For the purpose of this report this class of lattice has been divided into four categories, their properties and synthesis discussed separately.

If Z_{11} and Z_{12} are given, if they meet the conditions set for the type SL_1 , they will also meet the conditions set for SL_2 but for a phase reversal. But if the given specifications meet the conditions set for SL_3 or SL_4 , then they will not meet any other set of specifications.

PART III

TWO VARIABLE BRIDGED-T REACTANCE NETWORKS.

3.1 INTRODUCTION

As stated earlier, we shall consider two variable bridged-T reactance networks in this chapter. Fig. 3.1-1 shows a bridge-T network where the impedances Z_1 , Z_2 , Z_3 and Z_4 are reactance functions of p_1 and p_2 . There are a number of possibilities. However, we shall consider that any impedance to be a function of either p_1 or p_2 only. The different possibilities arising out of the above constraint are shown in Table 3.1-I. As can be seen, there are only three main categories:

- (i) three impedances of p_1 and one impedance of p_2
- (ii) three impedances of p_2 and one impedance of p_1
- (iii) two impedances of p_1 and two impedances of p_2

In the above three categories, if we put $p_1 = 1$ or $p_2 = 1$ there results a general R-L-C network in a single variable either in p_2 or in p_1 . However, after putting $p_1 = 1$ (or $p_2 = 1$) and considering only one type of reactive element in the other variable (capacitances or inductances), there results two-element kind network.

3.2 PROPERTIES OF BRIDGED-T NETWORK IN TWO VARIABLES

Here the properties of the bridged-T network will be examined.

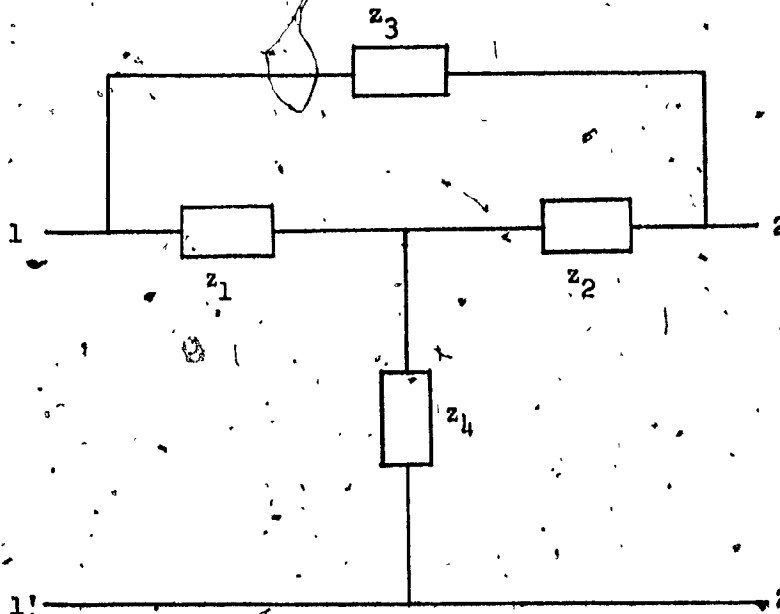

Fig. 3.1-1

Typical Bridged-T Network in Two Variables.

(The impedances z_1 , z_2 , z_3 and z_4 are reactance functions of either p_1 or p_2)

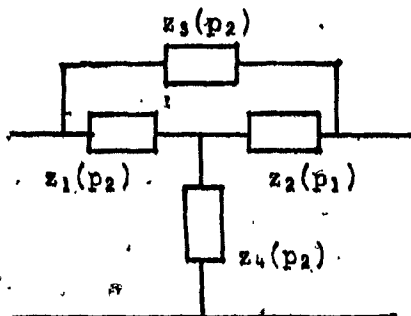
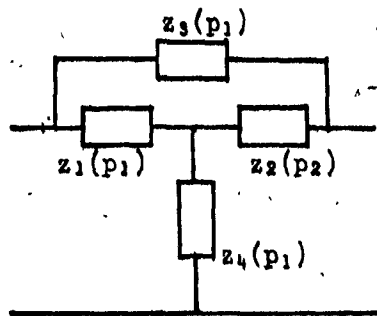
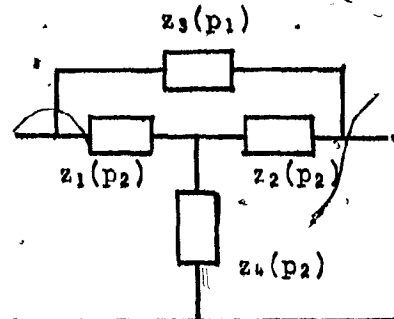
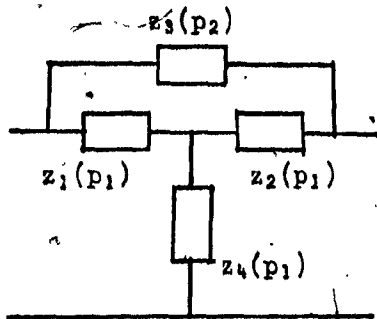
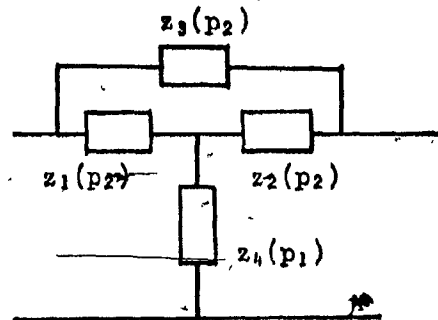
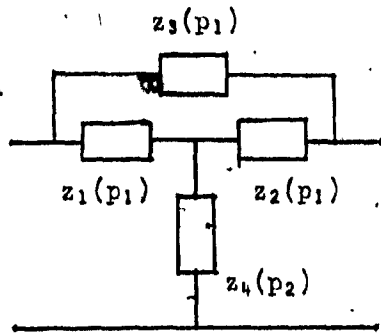

Table 3.1-1

Cont'd

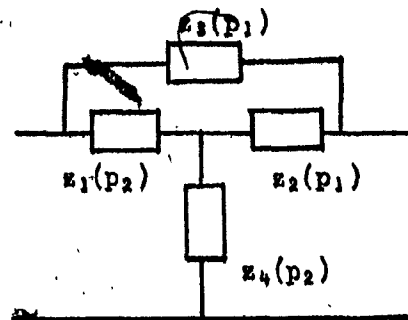
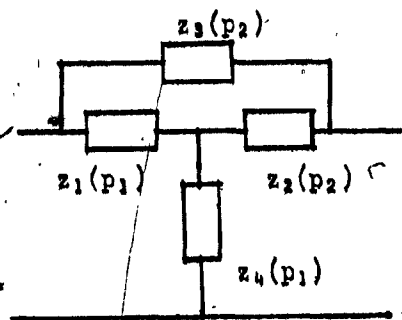
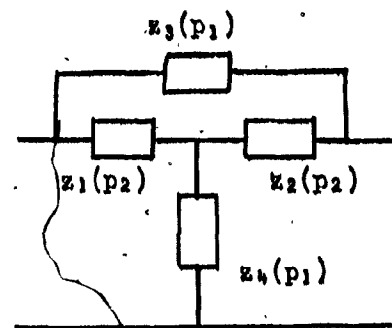
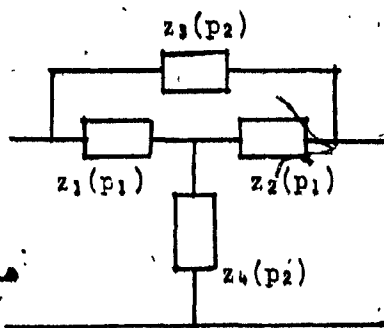
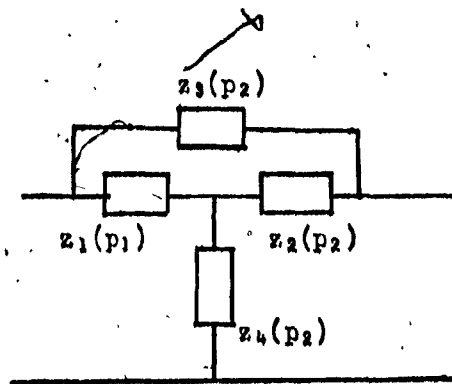
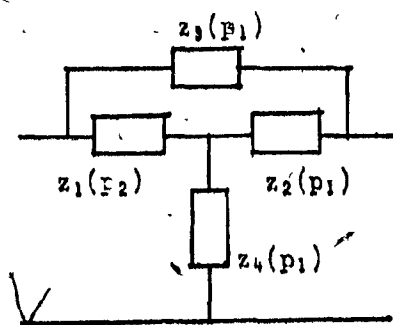

Table 3.1-1

Cont'd

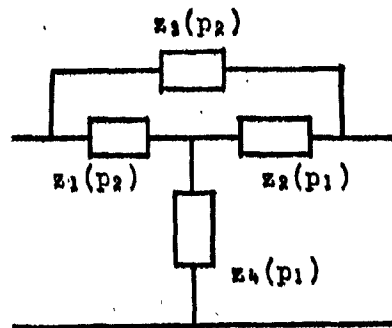
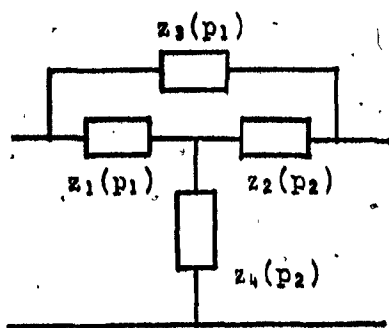

Table 3.1-1

Total Possible Cases of Bridged-T Networks in Two Variables.
When each Impidance is the function of one variable
only.

The network is shown in the previous section in Fig. 3.1. The corresponding Z_{11} , Z_{22} , Z_{12} and Y_{11} , Y_{22} , Y_{12} , are:

$$Z_{11}(p_1, p_2) = \frac{Z_1 Z_2 + Z_1 Z_3 + Z_1 Z_4 + Z_4 Z_2 + Z_4 Z_3}{Z_1 + Z_2 + Z_3} \dots \dots \dots 3.2-1$$

$$Z_{22}(p_1, p_2) = \frac{Z_2 Z_1 + Z_2 Z_3 + Z_4 Z_1 + Z_4 Z_2 + Z_4 Z_3}{Z_1 + Z_2 + Z_3} \dots \dots \dots 3.2-2$$

$$Z_{12}(p_1, p_2) = \frac{- \{ Z_4 Z_1 + Z_4 Z_2 + Z_4 Z_3 + Z_1 Z_2 \}}{Z_1 + Z_2 + Z_3} \dots \dots \dots 3.2-3$$

$$Y_{11}(p_1, p_2) = \frac{Y_3 Y_2 + Y_3 Y_4 + Y_3 Y_1 + Y_3 Y_2 + Y_3 Y_4}{Y_1 + Y_2 + Y_4} \dots \dots \dots 3.2-4$$

$$Y_{12}(p_1, p_2) = \frac{- \{ Y_3 Y_1 + Y_3 Y_2 + Y_3 Y_4 + Y_1 Y_2 \}}{Y_1 + Y_2 + Y_4} \dots \dots \dots 3.2-5$$

and

$$Y_{22}(p_1, p_2) = \frac{Y_3 Y_1 + Y_3 Y_2 + Y_3 Y_4 + Y_2 Y_1 + Y_2 Y_4}{Y_1 + Y_2 + Y_4} \dots \dots \dots 3.2-6$$

In these expressions, when we put $p_1 = 1$ and/or $p_2 = 1$ there results two types of bridged-T networks, namely:

- i) two element type (types B_1 and B_2) consisting of two elements
RL or RC
- ii) three element type (type B_3) consisting of all the three elements
R, L and C.

3.3 PROPERTIES OF BRIDGED-T NETWORKS OF TYPE B_1 AND B_2

The existence of these networks depends upon the nature of the reactances used. They can be obtained as following:

- (i) Type B_1 : The network consisting of p_1 type capacitors and p_2 type inductors. In this category, if $p_1 = 1$ the resulting network is R-L type, whereas if $p_2 = 1$ the network is RC type;
- (ii) Type B_2 : The network consisting of p_1 type inductors and p_2 type capacitors. In this category if $p_1 = 1$ the resulting is RC type and if $p_2 = 1$ the resulting network is of RL type. All the possible networks are shown in Table 3.2-1.

Some general properties of such bridged-T networks (Type B_1 and B_2) can be observed:

- (i) The poles of the Z matrix (y matrix) with p_1 or $p_2 = 1$ shall be simple and lie on the negative real axis of the variable p_2 or p_1 respectively.
- (ii) The zeros of the Z_{11} , Z_{22} , Y_{11} and Y_{22} with p_1 or $p_2 = 1$ shall be simple and lie on the negative real axis of the variable p_2 or p_1 respectively.
- (iii) None of these networks can have transmission zeros on the imaginary axis or right of p_1 or p_2 plane when the other variable is made equal to unity.

	$Z_{11}(p_1, p_2) = \frac{L_1 p_2 + 1/c_1 p_2}{c_1 p_2 + (L_1 p_2 + 1/c_1 p_2) p_2}$ $Z_{12}(p_1, p_2) = \frac{L_1 p_2 + 1/c_1 p_2}{c_1 + (L_1 p_2 + 1/c_1 p_2) p_2}$ $Z_{22}(p_1, p_2) = \frac{1/c_1 p_2 + (L_1 p_2 + 1/c_1 p_2) p_2}{c_1 + (L_1 p_2 + 1/c_1 p_2) p_2}$	$Z_{11}(p_1, p_2) = \frac{L_1 p_2 + 1/c_1 p_2}{c_1 + (L_1 p_2 + 1/c_1 p_2) p_2}$ $Z_{12}(p_1, p_2) = \frac{L_1 p_2 + 1/c_1 p_2}{c_1 + (L_1 p_2 + 1/c_1 p_2) p_2}$ $Z_{22}(p_1, p_2) = \frac{L_1 p_2 + 1/c_1 p_2}{c_1 + (L_1 p_2 + 1/c_1 p_2) p_2}$	$Z_{11}(p_1, p_2) = \frac{L_1 p_2 + 1/c_1 p_2}{c_1 p_2 + (L_1 p_2 + 1/c_1 p_2) p_2}$ $Z_{12}(p_1, p_2) = \frac{L_1 p_2 + 1/c_1 p_2}{c_1 p_2 + (L_1 p_2 + 1/c_1 p_2) p_2}$ $Z_{22}(p_1, p_2) = \frac{L_1 p_2 + 1/c_1 p_2}{c_1 p_2 + (L_1 p_2 + 1/c_1 p_2) p_2}$
	$Z_{11}(p_1, p_2) = \frac{L_1 p_2 + 1/c_1 p_2}{c_1 + (L_1 p_2 + 1/c_1 p_2) p_2}$ $Z_{12}(p_1, p_2) = \frac{L_1 p_2 + 1/c_1 p_2}{c_1 + (L_1 p_2 + 1/c_1 p_2) p_2}$ $Z_{22}(p_1, p_2) = \frac{L_1 p_2 + 1/c_1 p_2}{c_1 + (L_1 p_2 + 1/c_1 p_2) p_2}$	$Z_{11}(p_1, p_2) = \frac{L_1 p_2 + 1/c_1 p_2}{c_1 + (L_1 p_2 + 1/c_1 p_2) p_2}$ $Z_{12}(p_1, p_2) = \frac{L_1 p_2 + 1/c_1 p_2}{c_1 + (L_1 p_2 + 1/c_1 p_2) p_2}$ $Z_{22}(p_1, p_2) = \frac{L_1 p_2 + 1/c_1 p_2}{c_1 + (L_1 p_2 + 1/c_1 p_2) p_2}$	$Z_{11}(p_1, p_2) = \frac{L_1 p_2 + 1/c_1 p_2}{c_1 p_2 + (L_1 p_2 + 1/c_1 p_2) p_2}$ $Z_{12}(p_1, p_2) = \frac{L_1 p_2 + 1/c_1 p_2}{c_1 p_2 + (L_1 p_2 + 1/c_1 p_2) p_2}$ $Z_{22}(p_1, p_2) = \frac{L_1 p_2 + 1/c_1 p_2}{c_1 p_2 + (L_1 p_2 + 1/c_1 p_2) p_2}$

TABLE 3.2-1 — Z_{11} , Z_{22} and Z_{12} of the Bridged-T Networks of the kind B_1 and B_2 in Variables (p_1, p_2) and in Single Variable $(1, p_2)$ and $(p_1, 1)$.

	$Z_{11}(s, \omega) = \frac{1 + (L_{sp2} + \frac{1}{c_{sp2}}) \omega^2}{(c_{sp2})^2 + (L_{sp2} \omega)^2}$	$Z_{11}(s, \omega) = \frac{1 + (L_{sp2} + \frac{1}{c_{sp2}}) \omega^2}{(c_{sp2})^2 + (L_{sp2} \omega)^2}$	$Z_{11}(s, \omega) = \frac{1 + (L_{sp2} + \frac{1}{c_{sp2}}) \omega^2}{(c_{sp2})^2 + (L_{sp2} \omega)^2}$
	$Z_{21}(s, \omega) = \frac{1 + (L_{sp2} + \frac{1}{c_{sp2}}) \omega^2}{(c_{sp2})^2 + (L_{sp2} \omega)^2}$	$Z_{21}(s, \omega) = \frac{1 + (L_{sp2} + \frac{1}{c_{sp2}}) \omega^2}{(c_{sp2})^2 + (L_{sp2} \omega)^2}$	$Z_{21}(s, \omega) = \frac{1 + (L_{sp2} + \frac{1}{c_{sp2}}) \omega^2}{(c_{sp2})^2 + (L_{sp2} \omega)^2}$
	$Z_{12}(s, \omega) = \frac{1 + (L_{sp2} + \frac{1}{c_{sp2}}) \omega^2}{(c_{sp2})^2 + (L_{sp2} \omega)^2}$	$Z_{12}(s, \omega) = \frac{1 + (L_{sp2} + \frac{1}{c_{sp2}}) \omega^2}{(c_{sp2})^2 + (L_{sp2} \omega)^2}$	$Z_{12}(s, \omega) = \frac{1 + (L_{sp2} + \frac{1}{c_{sp2}}) \omega^2}{(c_{sp2})^2 + (L_{sp2} \omega)^2}$
	$Z_{22}(s, \omega) = \frac{1 + (L_{sp2} + \frac{1}{c_{sp2}}) \omega^2}{(c_{sp2})^2 + (L_{sp2} \omega)^2}$	$Z_{22}(s, \omega) = \frac{1 + (L_{sp2} + \frac{1}{c_{sp2}}) \omega^2}{(c_{sp2})^2 + (L_{sp2} \omega)^2}$	$Z_{22}(s, \omega) = \frac{1 + (L_{sp2} + \frac{1}{c_{sp2}}) \omega^2}{(c_{sp2})^2 + (L_{sp2} \omega)^2}$

Table 3.2-1 cont'd.

	$Z_{11}(p_1, p_2) = \frac{(c_1 p_1 + c_2) + (L_1 c_1 c_2 p_1 + L_2 c_1 c_2 p_2)}{(c_1 + c_2) p_1 + (L_1 c_1 c_2 p_1 + L_2 c_1 c_2 p_2)}$ $Z_{12}(p_1, p_2) = \frac{c_1 L_1 p_1}{(c_1 + c_2) p_1 + (L_1 c_1 c_2 p_1 + L_2 c_1 c_2 p_2)}$ $Z_{21}(p_1, p_2) = \frac{c_2 L_2 p_2}{(c_1 + c_2) p_1 + (L_1 c_1 c_2 p_1 + L_2 c_1 c_2 p_2)}$	$Z_{11}(1, p_2) = \frac{(c_1 + c_2) + (L_1 c_1 c_2 + L_2 c_1 c_2) p_2}{(c_1 + c_2) + (L_1 c_1 c_2 + L_2 c_1 c_2) p_2}$ $Z_{12}(1, p_2) = \frac{c_1 L_1 p_2}{(c_1 + c_2) + (L_1 c_1 c_2 + L_2 c_1 c_2) p_2}$ $Z_{21}(1, p_2) = \frac{c_2 L_2 p_2}{(c_1 + c_2) + (L_1 c_1 c_2 + L_2 c_1 c_2) p_2}$	$Z_{11}(p_1, 1) = \frac{(c_1 + c_2) + (L_1 c_1 c_2 + L_2 c_1 c_2) p_1}{(c_1 + c_2) p_1 + (L_1 c_1 c_2 p_1 + L_2 c_1 c_2 p_2)}$ $Z_{12}(p_1, 1) = \frac{c_1 L_1 p_1}{(c_1 + c_2) p_1 + (L_1 c_1 c_2 p_1 + L_2 c_1 c_2 p_2)}$ $Z_{21}(p_1, 1) = \frac{c_2 L_2 p_1}{(c_1 + c_2) p_1 + (L_1 c_1 c_2 p_1 + L_2 c_1 c_2 p_2)}$
	$Z_{11}(p_1, p_2) = \frac{(c_1 + c_2) + (L_1 c_1 c_2 p_1 + L_2 c_1 c_2 p_2)}{(c_1 + c_2) p_1 + (L_1 c_1 c_2 p_1 + L_2 c_1 c_2 p_2)}$ $Z_{12}(p_1, p_2) = \frac{c_1 L_1 p_1}{(c_1 + c_2) p_1 + (L_1 c_1 c_2 p_1 + L_2 c_1 c_2 p_2)}$ $Z_{21}(p_1, p_2) = \frac{c_2 L_2 p_2}{(c_1 + c_2) p_1 + (L_1 c_1 c_2 p_1 + L_2 c_1 c_2 p_2)}$	$Z_{11}(1, p_2) = \frac{(c_1 + c_2) + (L_1 c_1 c_2 + L_2 c_1 c_2) p_2}{(c_1 + c_2) + (L_1 c_1 c_2 + L_2 c_1 c_2) p_2}$ $Z_{12}(1, p_2) = \frac{c_1 L_1 p_2}{(c_1 + c_2) + (L_1 c_1 c_2 + L_2 c_1 c_2) p_2}$ $Z_{21}(1, p_2) = \frac{c_2 L_2 p_2}{(c_1 + c_2) + (L_1 c_1 c_2 + L_2 c_1 c_2) p_2}$	$Z_{11}(p_1, 1) = \frac{(c_1 + c_2) + (L_1 c_1 c_2 + L_2 c_1 c_2) p_1}{(c_1 + c_2) p_1 + (L_1 c_1 c_2 p_1 + L_2 c_1 c_2 p_2)}$ $Z_{12}(p_1, 1) = \frac{c_1 L_1 p_1}{(c_1 + c_2) p_1 + (L_1 c_1 c_2 p_1 + L_2 c_1 c_2 p_2)}$ $Z_{21}(p_1, 1) = \frac{c_2 L_2 p_1}{(c_1 + c_2) p_1 + (L_1 c_1 c_2 p_1 + L_2 c_1 c_2 p_2)}$

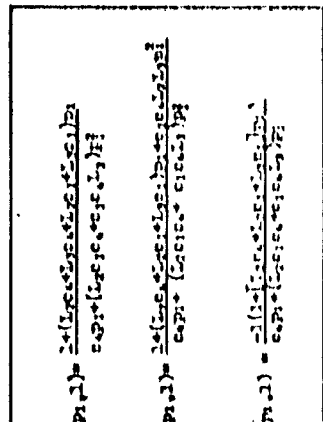
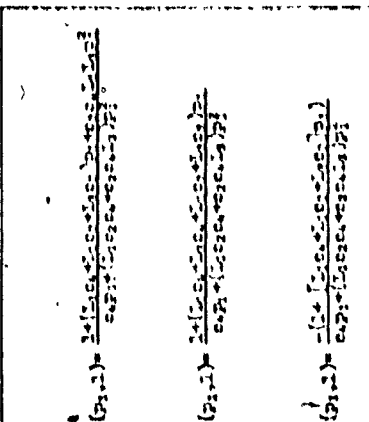
TABLE 3.2-1 Cont'd.

	$Z_{11}(p_1, p_2) = \frac{(c_1+c_2c_1) + (L_1c_1c_2 + L_2c_1c_2)p_1p_2}{(c_1+c_2c_1)p_1 + (c_1c_2L_1)L_2p_2}$	$Z_{11}(1, p_2) = \frac{(c_1+c_2c_1) + (L_1c_1c_2 + L_2c_1c_2)p_2}{(c_1+c_2c_1) + (c_1c_2L_1)L_2p_2}$	$Z_{11}(p_1, 1) = \frac{(c_1+c_2c_1) + (L_1c_1c_2 + L_2c_1c_2)p_1}{(c_1+c_2c_1)p_1 + (c_1c_2L_1)L_2}$
	$Z_{22}(p_1, p_2) = \frac{(c_1+c_2) + (L_1c_1c_2 + L_2c_1c_2)p_1p_2}{(c_1+c_2c_1)p_1 + (c_1c_2L_1)L_2p_2}$	$Z_{22}(1, p_2) = \frac{(c_1+c_2) + (L_1c_1c_2 + L_2c_1c_2)p_2}{(c_1+c_2c_1) + (c_1c_2L_1)L_2p_2}$	$Z_{22}(p_1, 1) = \frac{(c_1+c_2) + (L_1c_1c_2 + L_2c_1c_2)p_1}{(c_1+c_2c_1)p_1 + (c_1c_2L_1)L_2}$
	$Z_{12}(1, p_2) = \frac{-(c_1+c_2c_1) + (L_1c_1c_2)p_2}{(c_1+c_2c_1) + (c_1c_2L_1)L_2p_2}$	$Z_{12}(1, p_2) = \frac{-(c_1+c_2c_1) + (L_1c_1c_2)p_2}{(c_1+c_2c_1) + (c_1c_2L_1)L_2p_2}$	$Z_{12}(p_1, 1) = \frac{-(c_1+c_2c_1) + (L_1c_1c_2)p_1}{(c_1+c_2c_1)p_1 + (c_1c_2L_1)L_2}$
	$Z_{11}(1, p_2) = \frac{L_2c_1c_2L_1c_1c_2p_1p_2}{(c_1+c_2) + (L_1c_1c_2 + L_2c_1c_2)p_1p_2}$	$Z_{11}(1, p_2) = \frac{L_2c_1c_2L_1c_1c_2p_2}{(c_1+c_2) + (L_1c_1c_2 + L_2c_1c_2)p_2}$	$Z_{11}(p_1, 1) = \frac{L_2c_1c_2L_1c_1c_2p_1}{(c_1+c_2c_1)p_1 + (L_1c_1c_2 + L_2c_1c_2)p_1}$
	$Z_{22}(1, p_2) = \frac{L_2c_1c_2L_1c_1c_2p_1p_2}{(c_1+c_2c_1)p_1 + (L_1c_1c_2 + L_2c_1c_2)p_2}$	$Z_{22}(1, p_2) = \frac{L_2c_1c_2L_1c_1c_2p_2}{(c_1+c_2c_1) + (L_1c_1c_2 + L_2c_1c_2)p_2}$	$Z_{22}(p_1, 1) = \frac{L_2c_1c_2L_1c_1c_2p_1}{(c_1+c_2c_1)p_1 + (L_1c_1c_2 + L_2c_1c_2)p_1}$
	$Z_{12}(1, p_2) = \frac{-(L_1 + L_2c_1c_2) + (L_1L_2c_1c_2)p_2}{(c_1+c_2) + (L_1c_1c_2 + L_2c_1c_2)p_2}$	$Z_{12}(1, p_2) = \frac{-(L_1 + L_2c_1c_2) + (L_1L_2c_1c_2)p_2}{(c_1+c_2) + (L_1c_1c_2 + L_2c_1c_2)p_2}$	$Z_{12}(p_1, 1) = \frac{-(L_1 + L_2c_1c_2) + (L_1L_2c_1c_2)p_1}{(c_1+c_2c_1)p_1 + (L_1c_1c_2 + L_2c_1c_2)p_1}$

TABLE 3.2-1 Cont'd.

	$Z_{11}(P_1, P_2) = \frac{(L_2 + L_3)P_2 + (L_1 L_2 c_1 P_1 + L_2 c_1 P_1 P_2)}{1 + (L_1 + L_2) c_1 P_1 P_2}$	$Z_{11}(1, P_2) = \frac{(L_2 + L_3)P_2 + (L_1 L_2 c_1 + L_2 c_1 P_2)}{1 + (L_1 + L_2) c_1 P_2}$	$Z_{11}(P_1, 1) = \frac{(L_2 + L_3) + (L_1 L_2 c_1 + L_2 c_1 P_1)}{1 + (L_1 + L_2) c_1 P_1}$
	$Z_{12}(P_1, P_2) = \frac{(L_2 + L_3)P_2 + (L_1 L_2 c_1 + L_2 c_1 P_2)}{1 + (L_1 + L_2) c_1 P_1 P_2}$	$Z_{12}(1, P_2) = \frac{(L_2 + L_3)P_2 + (L_1 L_2 c_1 + L_2 c_1 P_2)}{1 + (L_1 + L_2) c_1 P_2}$	$Z_{12}(P_1, 1) = \frac{(L_2 + L_3) + (L_1 L_2 c_1 + L_2 c_1 P_1)}{1 + (L_1 + L_2) c_1 P_1}$
	$Z_{21}(P_1, P_2) = \frac{(L_2 + L_3 + L_1)P_2 + (L_1 L_2 c_1 + L_1 L_3 c_1 P_1)}{c_1 (L_1 + L_2 + L_3) P_1 P_2}$	$Z_{21}(1, P_2) = \frac{(L_2 + L_3 + L_1)P_2 + (L_1 L_2 c_1 + L_1 L_3 c_1 P_2)}{c_1 (L_1 + L_2 + L_3) P_2}$	$Z_{21}(P_1, 1) = \frac{(L_2 + L_3 + L_1) + (L_1 L_2 c_1 + L_1 L_3 c_1 P_1)}{c_1 (L_1 + L_2 + L_3) P_1}$
	$Z_{22}(P_1, P_2) = \frac{(L_2 + L_3 + L_1)P_2 + (L_1 L_2 c_1 + L_1 L_3 c_1 P_1)}{c_1 (L_1 + L_2 + L_3) P_1 P_2}$	$Z_{22}(1, P_2) = \frac{(L_2 + L_3 + L_1)P_2 + (L_1 L_2 c_1 + L_1 L_3 c_1 P_2)}{c_1 (L_1 + L_2 + L_3) P_2}$	$Z_{22}(P_1, 1) = \frac{(L_2 + L_3 + L_1) + (L_1 L_2 c_1 + L_1 L_3 c_1 P_1)}{c_1 (L_1 + L_2 + L_3) P_1}$

TABLE 3.2-1 Cont'd.

	$Z_{11}(p_1, p_2) = \frac{1 + (L_{p1}c_{p2} + L_{p2}c_{p1})p_1p_2}{c_{p2} + (L_{p1}c_{p1} + L_{p2}c_{p2})p_1^2}$ $Z_{22}(p_1, p_2) = \frac{1 + (L_{p1}c_{p1} + L_{p2}c_{p2})p_1p_2}{c_{p2} + (L_{p1}c_{p1} + L_{p2}c_{p2})p_1^2}$ $Z_{12}(p_1, p_2) = \frac{-1 + (L_{p1}c_{p1} + L_{p2}c_{p2})p_1p_2}{c_{p2} + (L_{p1}c_{p1} + L_{p2}c_{p2})p_1^2}$	$Z_{11}(p_1, 1) = \frac{1 + (L_{p1}c_{p2} + L_{p2}c_{p1})p_1}{c_{p2} + (L_{p1}c_{p1} + L_{p2}c_{p2})p_1}$ $Z_{22}(p_1, 1) = \frac{1 + (L_{p1}c_{p1} + L_{p2}c_{p2})p_1}{c_{p2} + (L_{p1}c_{p1} + L_{p2}c_{p2})p_1}$ $Z_{12}(p_1, 1) = \frac{-1 + (L_{p1}c_{p1} + L_{p2}c_{p2})p_1}{c_{p2} + (L_{p1}c_{p1} + L_{p2}c_{p2})p_1}$	$Z_{11}(0, p_2) = \frac{1 + (L_{p1}c_{p2} + L_{p2}c_{p1})p_2}{c_{p2} + (L_{p1}c_{p1} + L_{p2}c_{p2})p_2^2}$ $Z_{22}(0, p_2) = \frac{1 + (L_{p1}c_{p1} + L_{p2}c_{p2})p_2}{c_{p2} + (L_{p1}c_{p1} + L_{p2}c_{p2})p_2^2}$ $Z_{12}(0, p_2) = \frac{-1 + (L_{p1}c_{p1} + L_{p2}c_{p2})p_2}{c_{p2} + (L_{p1}c_{p1} + L_{p2}c_{p2})p_2^2}$
	$Z_{11}(p_1, p_2) = \frac{1 - (L_{p1}c_{p2} + L_{p2}c_{p1})p_1p_2}{c_{p2} + (L_{p1}c_{p1} + L_{p2}c_{p2})p_1^2}$ $Z_{22}(p_1, p_2) = \frac{1 - (L_{p1}c_{p1} + L_{p2}c_{p2})p_1p_2}{c_{p2} + (L_{p1}c_{p1} + L_{p2}c_{p2})p_1^2}$ $Z_{12}(p_1, p_2) = \frac{-1 + (L_{p1}c_{p1} + L_{p2}c_{p2})p_1p_2}{c_{p2} + (L_{p1}c_{p1} + L_{p2}c_{p2})p_1^2}$	$Z_{11}(p_1, 1) = \frac{1 - (L_{p1}c_{p2} + L_{p2}c_{p1})p_1}{c_{p2} + (L_{p1}c_{p1} + L_{p2}c_{p2})p_1}$ $Z_{22}(p_1, 1) = \frac{-1 + (L_{p1}c_{p1} + L_{p2}c_{p2})p_1}{c_{p2} + (L_{p1}c_{p1} + L_{p2}c_{p2})p_1}$ $Z_{12}(p_1, 1) = \frac{-1 + (L_{p1}c_{p1} + L_{p2}c_{p2})p_1}{c_{p2} + (L_{p1}c_{p1} + L_{p2}c_{p2})p_1}$	$Z_{11}(0, p_2) = \frac{1 - (L_{p1}c_{p2} + L_{p2}c_{p1})p_2}{c_{p2} + (L_{p1}c_{p1} + L_{p2}c_{p2})p_2^2}$ $Z_{22}(0, p_2) = \frac{-1 + (L_{p1}c_{p1} + L_{p2}c_{p2})p_2}{c_{p2} + (L_{p1}c_{p1} + L_{p2}c_{p2})p_2^2}$ $Z_{12}(0, p_2) = \frac{-1 + (L_{p1}c_{p1} + L_{p2}c_{p2})p_2}{c_{p2} + (L_{p1}c_{p1} + L_{p2}c_{p2})p_2^2}$

TABLE 3.2-1 Cont'd.

	$Z_{11}(p_1, p_2) = \frac{1 + (L_{c1} + L_{c2} + L_{c3})p_1 p_2 + (L_{c1} L_{c2} + L_{c1} L_{c3} + L_{c2} L_{c3})p_1^2 p_2^2}{(c_1 c_2) p_1^2 + (c_1 c_3) p_1 p_2^2}$	$Z_{11}(p_1, p_2) = \frac{1 + (L_{c1} + L_{c2} + L_{c3})p_1 p_2 + (L_{c1} L_{c2} + L_{c1} L_{c3} + L_{c2} L_{c3})p_1^2 p_2^2}{(c_1 c_2) p_1^2 + (c_1 c_3) p_1 p_2^2}$	$Z_{11}(1, p_2) = \frac{1 + (L_{c1} + L_{c2} + L_{c3})p_2 + (L_{c1} L_{c2} + L_{c1} L_{c3} + L_{c2} L_{c3})p_2^2}{(c_1 c_2) p_2^2 + (c_1 c_3) p_2}$
	$Z_{22}(p_1, p_2) = \frac{1 + (L_{c1} + L_{c2} + L_{c3})p_1 p_2 + (L_{c1} L_{c2} + L_{c1} L_{c3} + L_{c2} L_{c3})p_1^2 p_2^2}{(c_1 c_2) p_1^2 + (c_2 c_3) p_1 p_2^2}$	$Z_{22}(p_1, p_2) = \frac{1 + (L_{c1} + L_{c2} + L_{c3})p_1 p_2 + (L_{c1} L_{c2} + L_{c1} L_{c3} + L_{c2} L_{c3})p_1^2 p_2^2}{(c_1 c_2) p_1^2 + (c_2 c_3) p_1 p_2^2}$	$Z_{22}(1, p_2) = \frac{1 + (L_{c1} + L_{c2} + L_{c3})p_2 + (L_{c1} L_{c2} + L_{c1} L_{c3} + L_{c2} L_{c3})p_2^2}{(c_1 c_2) p_2^2 + (c_2 c_3) p_2}$
	$Z_{12}(p_1, p_2) = \frac{1 + (L_{c1} + L_{c2} + L_{c3})p_1 p_2 + (L_{c1} L_{c2} + L_{c1} L_{c3} + L_{c2} L_{c3})p_1^2 p_2^2}{(c_1 c_2) p_1^2 + (c_1 c_3) p_1 p_2^2}$	$Z_{12}(p_1, p_2) = \frac{1 + (L_{c1} + L_{c2} + L_{c3})p_1 p_2 + (L_{c1} L_{c2} + L_{c1} L_{c3} + L_{c2} L_{c3})p_1^2 p_2^2}{(c_1 c_2) p_1^2 + (c_1 c_3) p_1 p_2^2}$	$Z_{12}(1, p_2) = \frac{1 + (L_{c1} + L_{c2} + L_{c3})p_2 + (L_{c1} L_{c2} + L_{c1} L_{c3} + L_{c2} L_{c3})p_2^2}{(c_1 c_2) p_2^2 + (c_1 c_3) p_2}$

TABLE 3.2-1 Cont'd.

ORIGINALS MARKED

	$Z_{11}(p_1, p_2) = \frac{1 + (Z_{11} + Z_{12})(c_1 p_1 + c_1 p_2)}{c_1 p_2 + (c_1 p_1 + c_1 p_2) p_2}$ $Z_{21}(p_1, p_2) = \frac{Z_{12}(c_1 p_1 + c_1 p_2)}{c_1 p_2 + (c_1 p_1 + c_1 p_2) p_2}$ $Z_{22}(p_1, p_2) = \frac{1 + (Z_{11} + Z_{12})(c_1 p_1 + c_1 p_2)}{c_1 p_2 + (c_1 p_1 + c_1 p_2) p_2}$	$Z_{11}(p_1, p_2) = \frac{1 + (Z_{11} + Z_{12})(c_1 p_1 + c_1 p_2)}{c_1 p_2 + (c_1 p_1 + c_1 p_2) p_2}$ $Z_{21}(p_1, p_2) = \frac{Z_{12}(c_1 p_1 + c_1 p_2)}{c_1 p_2 + (c_1 p_1 + c_1 p_2) p_2}$ $Z_{22}(p_1, p_2) = \frac{1 + (Z_{11} + Z_{12})(c_1 p_1 + c_1 p_2)}{c_1 p_2 + (c_1 p_1 + c_1 p_2) p_2}$	$Z_{11}(1, p_2) = \frac{1 + (Z_{11} + Z_{12})(c_1 + c_1 p_2)}{c_1 p_2 + (c_1 + c_1 p_2) p_2}$ $Z_{21}(1, p_2) = \frac{Z_{12}(c_1 + c_1 p_2)}{c_1 p_2 + (c_1 + c_1 p_2) p_2}$ $Z_{22}(1, p_2) = \frac{1 + (Z_{11} + Z_{12})(c_1 + c_1 p_2)}{c_1 p_2 + (c_1 + c_1 p_2) p_2}$
	$Z_{11}(p_1, p_2) = \frac{1 + (Z_{11} + Z_{12})(c_1 p_1 + c_1 p_2)}{c_1 p_2 + (c_1 p_1 + c_1 p_2) p_2}$ $Z_{21}(p_1, p_2) = \frac{Z_{12}(c_1 p_1 + c_1 p_2)}{c_1 p_2 + (c_1 p_1 + c_1 p_2) p_2}$ $Z_{22}(p_1, p_2) = \frac{1 + (Z_{11} + Z_{12})(c_1 p_1 + c_1 p_2)}{c_1 p_2 + (c_1 p_1 + c_1 p_2) p_2}$	$Z_{11}(p_1, p_2) = \frac{1 + (Z_{11} + Z_{12})(c_1 p_1 + c_1 p_2)}{c_1 p_2 + (c_1 p_1 + c_1 p_2) p_2}$ $Z_{21}(p_1, p_2) = \frac{Z_{12}(c_1 p_1 + c_1 p_2)}{c_1 p_2 + (c_1 p_1 + c_1 p_2) p_2}$ $Z_{22}(p_1, p_2) = \frac{1 + (Z_{11} + Z_{12})(c_1 p_1 + c_1 p_2)}{c_1 p_2 + (c_1 p_1 + c_1 p_2) p_2}$	$Z_{11}(1, p_2) = \frac{1 + (Z_{11} + Z_{12})(c_1 + c_1 p_2)}{c_1 p_2 + (c_1 + c_1 p_2) p_2}$ $Z_{21}(1, p_2) = \frac{Z_{12}(c_1 + c_1 p_2)}{c_1 p_2 + (c_1 + c_1 p_2) p_2}$ $Z_{22}(1, p_2) = \frac{1 + (Z_{11} + Z_{12})(c_1 + c_1 p_2)}{c_1 p_2 + (c_1 + c_1 p_2) p_2}$

TABLE 3.2-1 Cont'd.

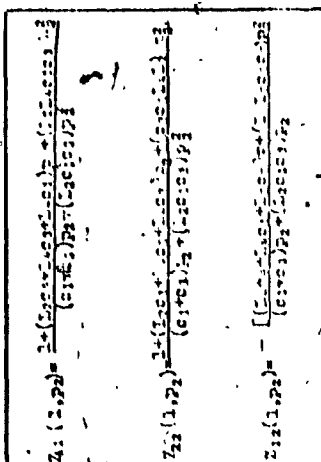
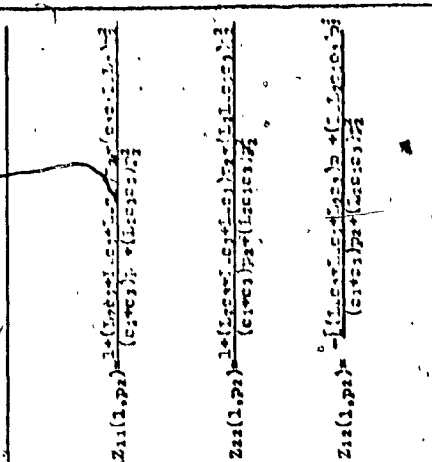
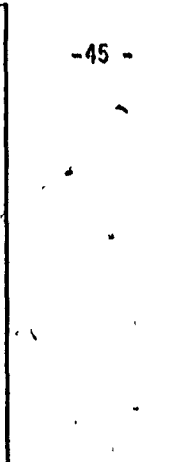
<p>Circuit diagram showing a voltage source $1/c_1 p_1$ in series with a branch containing $1/c_2 p_2$ and $1/c_3 p_3$ in parallel.</p>	$Z_{11}(1, 1) = \frac{(c_1 c_2 p_1 + c_1 c_3 p_1 + c_2 c_3 p_1) p_1}{(c_1 c_2 c_3 p_1)^2 + (c_1 c_2 c_3 p_1) p_1}$	$Z_{12}(1, 1) = \frac{(c_1 c_2 p_1 + c_1 c_3 p_1 + c_2 c_3 p_1) p_1}{(c_1 c_2 c_3 p_1)^2 + (c_1 c_2 c_3 p_1) p_1}$	$Z_{11}(1, p_2) = \frac{(c_1 c_2 p_1 + c_1 c_3 p_1 + c_2 c_3 p_1) p_1}{(c_1 c_2 c_3 p_1)^2 + (c_1 c_2 c_3 p_1) p_1}$
<p>Circuit diagram showing a voltage source $1/c_1 p_1$ in series with a branch containing $1/c_2 p_2$ and $1/c_3 p_3$ in parallel.</p>	$Z_{11}(1, 2) = \frac{(c_1 c_2 p_1 + c_1 c_3 p_1 + c_2 c_3 p_1) p_1}{(c_1 c_2 c_3 p_1)^2 + (c_1 c_2 c_3 p_1) p_1}$	$Z_{12}(1, 2) = \frac{(c_1 c_2 p_1 + c_1 c_3 p_1 + c_2 c_3 p_1) p_1}{(c_1 c_2 c_3 p_1)^2 + (c_1 c_2 c_3 p_1) p_1}$	$Z_{11}(1, p_2) = \frac{(c_1 c_2 p_1 + c_1 c_3 p_1 + c_2 c_3 p_1) p_1}{(c_1 c_2 c_3 p_1)^2 + (c_1 c_2 c_3 p_1) p_1}$
<p>Circuit diagram showing a voltage source $1/c_1 p_1$ in series with a branch containing $1/c_2 p_2$ and $1/c_3 p_3$ in parallel.</p>	$Z_{11}(2, 1) = \frac{(c_1 c_2 p_1 + c_1 c_3 p_1 + c_2 c_3 p_1) p_1}{(c_1 c_2 c_3 p_1)^2 + (c_1 c_2 c_3 p_1) p_1}$	$Z_{12}(2, 1) = \frac{(c_1 c_2 p_1 + c_1 c_3 p_1 + c_2 c_3 p_1) p_1}{(c_1 c_2 c_3 p_1)^2 + (c_1 c_2 c_3 p_1) p_1}$	$Z_{11}(1, p_2) = \frac{(c_1 c_2 p_1 + c_1 c_3 p_1 + c_2 c_3 p_1) p_1}{(c_1 c_2 c_3 p_1)^2 + (c_1 c_2 c_3 p_1) p_1}$
<p>Circuit diagram showing a voltage source $1/c_1 p_1$ in series with a branch containing $1/c_2 p_2$ and $1/c_3 p_3$ in parallel.</p>	$Z_{11}(2, 2) = \frac{(c_1 c_2 p_1 + c_1 c_3 p_1 + c_2 c_3 p_1) p_1}{(c_1 c_2 c_3 p_1)^2 + (c_1 c_2 c_3 p_1) p_1}$	$Z_{12}(2, 2) = \frac{(c_1 c_2 p_1 + c_1 c_3 p_1 + c_2 c_3 p_1) p_1}{(c_1 c_2 c_3 p_1)^2 + (c_1 c_2 c_3 p_1) p_1}$	$Z_{11}(1, p_2) = \frac{(c_1 c_2 p_1 + c_1 c_3 p_1 + c_2 c_3 p_1) p_1}{(c_1 c_2 c_3 p_1)^2 + (c_1 c_2 c_3 p_1) p_1}$

TABLE 3.2-1 Cont'd.



	$Z_{11}(s, z_1) = \frac{L_1 s + \frac{1}{s C_1} + L_2}{1 + (L_1 C_1 + L_2 C_1) s^2}$	$Z_{11}(s, z_1) = \frac{(L_1 + L_2) s + \frac{1}{s C_1}}{1 + (L_1 C_1 + L_2 C_1) s^2}$	$Z_{11}(s, z_1) = \frac{(L_1 + L_2) s + \frac{1}{s C_1}}{1 + (L_1 C_1 + L_2 C_1) s^2}$
	$Z_{21}(s, z_1) = \frac{(L_1 + L_2) s + \frac{1}{s C_1}}{1 + (L_1 C_1 + L_2 C_1) s^2}$	$Z_{21}(s, z_1) = \frac{(L_1 + L_2) s + \frac{1}{s C_1}}{1 + (L_1 C_1 + L_2 C_1) s^2}$	$Z_{21}(s, z_1) = \frac{(L_1 + L_2) s + \frac{1}{s C_1}}{1 + (L_1 C_1 + L_2 C_1) s^2}$
	$Z_{12}(s, z_1) = \frac{(L_1 + L_2) s + \frac{1}{s C_1}}{1 + (L_1 C_1 + L_2 C_1) s^2}$	$Z_{12}(s, z_1) = \frac{(L_1 + L_2) s + \frac{1}{s C_1}}{1 + (L_1 C_1 + L_2 C_1) s^2}$	$Z_{12}(s, z_1) = \frac{(L_1 + L_2) s + \frac{1}{s C_1}}{1 + (L_1 C_1 + L_2 C_1) s^2}$
	$Z_{22}(s, z_1) = \frac{(L_1 + L_2) s + \frac{1}{s C_1}}{1 + (L_1 C_1 + L_2 C_1) s^2}$	$Z_{22}(s, z_1) = \frac{(L_1 + L_2) s + \frac{1}{s C_1}}{1 + (L_1 C_1 + L_2 C_1) s^2}$	$Z_{22}(s, z_1) = \frac{(L_1 + L_2) s + \frac{1}{s C_1}}{1 + (L_1 C_1 + L_2 C_1) s^2}$

TABLE 3.2-1 Cont'd.

	$Z_{11}(s) = \frac{(sL_1 + \frac{1}{sC_1}) \cdot sL_2}{sL_1 + sL_2 + \frac{1}{sC_1}}$	$Z_{21}(s) = \frac{sL_2}{sL_1 + sL_2 + \frac{1}{sC_1}}$	$Z_{31}(s) = \frac{1}{sC_1} \cdot \frac{sL_2}{sL_1 + sL_2 + \frac{1}{sC_1}}$
	$Z_{12}(s) = \frac{sL_2}{sL_1 + sL_2 + \frac{1}{sC_1}}$	$Z_{22}(s) = \frac{sL_2}{sL_1 + sL_2 + \frac{1}{sC_1}}$	$Z_{32}(s) = \frac{1}{sC_1} \cdot \frac{sL_2}{sL_1 + sL_2 + \frac{1}{sC_1}}$
	$Z_{13}(s) = \frac{1}{sC_1} \cdot \frac{sL_2}{sL_1 + sL_2 + \frac{1}{sC_1}}$	$Z_{23}(s) = \frac{1}{sC_1} \cdot \frac{sL_2}{sL_1 + sL_2 + \frac{1}{sC_1}}$	$Z_{33}(s) = \frac{1}{sC_1} \cdot \frac{sL_2}{sL_1 + sL_2 + \frac{1}{sC_1}}$
	$Z_{11}(s) = \frac{1}{\frac{1}{sL_1} + \frac{1}{sL_2 + \frac{1}{sC_1}}}$	$Z_{21}(s) = \frac{sL_2}{sL_1 + sL_2 + \frac{1}{sC_1}}$	$Z_{31}(s) = \frac{1}{sC_1} \cdot \frac{sL_2}{sL_1 + sL_2 + \frac{1}{sC_1}}$
	$Z_{12}(s) = \frac{sL_2}{sL_1 + sL_2 + \frac{1}{sC_1}}$	$Z_{22}(s) = \frac{sL_2}{sL_1 + sL_2 + \frac{1}{sC_1}}$	$Z_{32}(s) = \frac{1}{sC_1} \cdot \frac{sL_2}{sL_1 + sL_2 + \frac{1}{sC_1}}$
	$Z_{13}(s) = \frac{1}{sC_1} \cdot \frac{sL_2}{sL_1 + sL_2 + \frac{1}{sC_1}}$	$Z_{23}(s) = \frac{1}{sC_1} \cdot \frac{sL_2}{sL_1 + sL_2 + \frac{1}{sC_1}}$	$Z_{33}(s) = \frac{1}{sC_1} \cdot \frac{sL_2}{sL_1 + sL_2 + \frac{1}{sC_1}}$

TABLE 3.2-1 Cont'd.

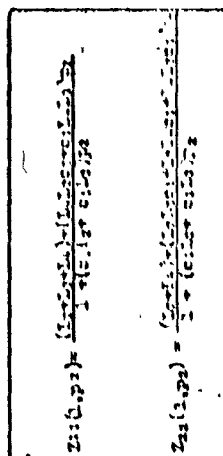
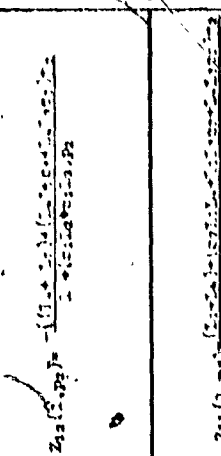
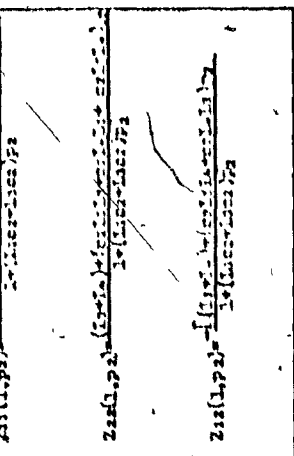
- (iv) None of these networks with $p_1 = 1$ or $p_2 = 1$ can give a constant resistance network.

3.4 PROPERTIES OF BRIDGED-T NETWORK WHOSE $Z_{11}(P_1, 1)$ AND $Z_{11}(1, P_2)$ ARE POSITIVE REAL FUNCTIONS

In the previous section the properties of the bridged-T network are discussed when $z_{11}(p_1, 1)$ and $z_{11}(1, p_2)$ are two element kind functions. Here the properties of the Bridged-T network (Type B₃) will be discussed when $z_{11}(p_1, 1)$ and $z_{11}(1, p_2)$ are Positive real functions.

Contrary to the previous case, here by putting $p_1 = 1$ or $p_2 = 1$ we get only RLC networks and as a consequence z_{11} and z_{22} are positive real functions in the variable which is not but equal to unity.

Some general properties of such functions can be written as:

- i) The poles of z_{11} and z_{22} with p_1 or p_2 equal unity, shall lie on the left half plane of the variable p_2 or p_1 respectively.
- ii) The zeros of z_{11} and z_{22} with p_1 or p_2 equal to unity shall lie on the left half plane of the variable p_2 or p_1 respectively.
- iii) None of these networks can have transmission zeros on the imaginary axis as in the right half of p_1 or p_2 plane when the other variable is made equal to unity.
- iv) Some of the networks can be made constant resistance networks by a suitable choice of the different elements.

For the purpose of this report, only the networks which yield constant

resistance networks will be discussed further. Table 3.3-I gives the possible constant resistance networks of the Bridged-T.

3.5 PROPERTIES OF BRIDGED-T NETWORKS RESULTING IN SINGLE VARIABLE CONSTANT RESISTANCE NETWORKS

These types of bridged-T networks can be synthesized using the synthesis techniques available for single variable constant resistance networks [1]. Here the conditions under which a two variable reactance function can be synthesized using such bridged-T networks are [1],

$$\text{or } [Z_{11}(p_1, 1)]^2 - [Z_{12}(p_1, 1)]^2 = \text{constant.} \dots \dots \dots 3.3-1$$

$$[Z_{11}(1, p_2)]^2 - [Z_{12}(1, p_2)]^2 = \text{constant.} \dots \dots \dots 3.3-2$$

The synthesis procedure is as follows:

1) Depending on (3.3-1) or (3.3-2) being satisfied, synthesize $Z(p_1, 1)$ or $Z(1, p_2)$ which is terminated by one ohm resistance.

ii) Replace the resistance by appropriate capacitance or inductance by the following test:

i) If $Z_{11}(p_1, 1)$ has a pole at origin on plane p_1 , then R will be replaced by capacitor in plane p_2 whose value is equal to $\frac{1}{R}$ farads.

ii) If $Z_{11}(1, p_2)$ has a pole at origin on plane p_2 then R is replaced by capacitor in plane p_2 , whose value is equal to $1/R$ farads.

Conditions to be terminated in L_1 load

Single Variable (l_1, p_2)

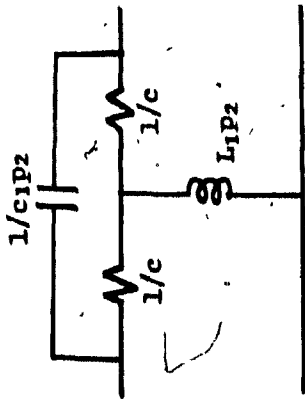

$$L_1 = c_1$$

$$c = 1$$

Two Variables (p_1, p_2)

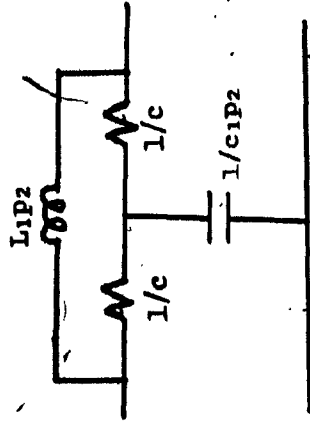
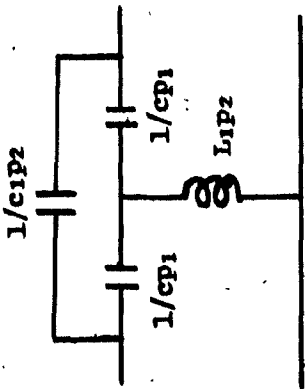

$$L_1 = c_1$$

$$c = 1$$

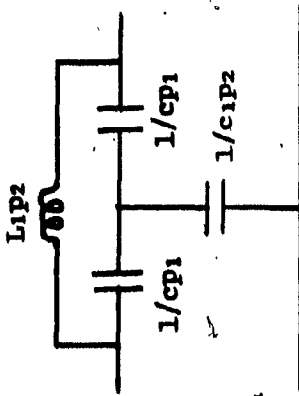
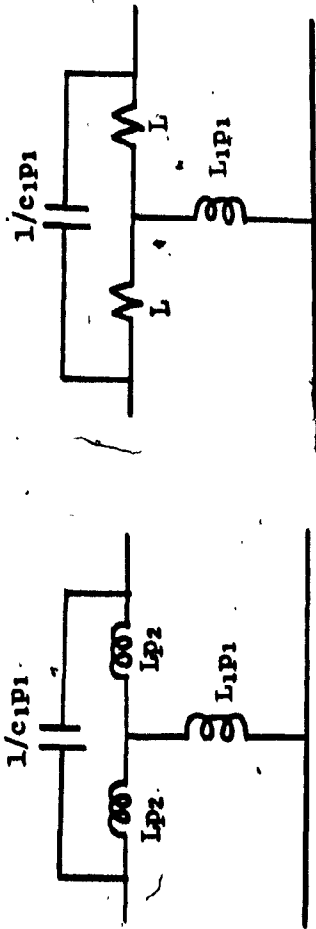

Table 3.3- Cont.

Conditions to be terminated in
 Ω load

Single Variable ($p_1, 1$)



$$\begin{aligned} C_1 &= L_1 \\ L &= 1 \end{aligned}$$

$$\begin{aligned} C_1 &= L_1 \\ L &= 1 \end{aligned}$$

Table 3.3-1 Cont'd.

Conditions to be terminated
in 1Ω Load

Single Variable ($p_1, 1$)

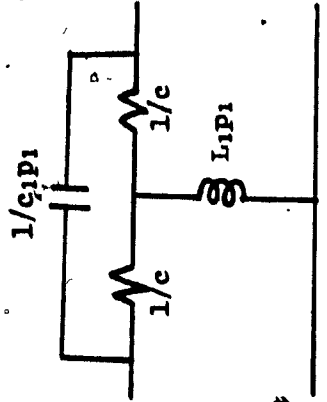

$$L_1 = c_1$$

$$c = 1$$

Two Variable (p_1, p_2)

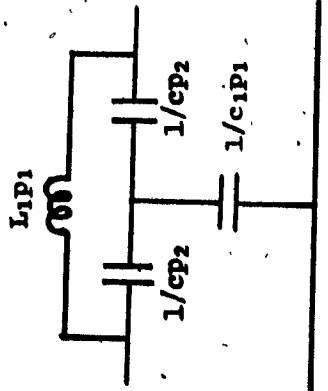
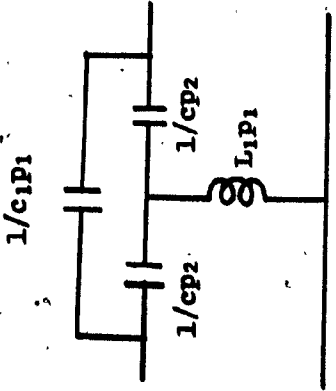

$$L_1 = c_1$$

$$c = 1$$

Table 3.3-1

Two variables (p_1, p_2)

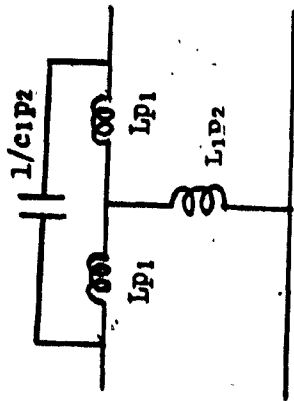

Single Variable (l, p_2)

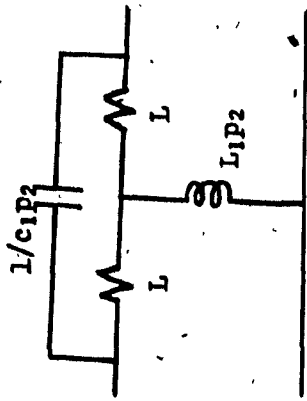

Conditions to be terminated
in l_0 load

$$L_1 = c_1$$

$$L = l$$

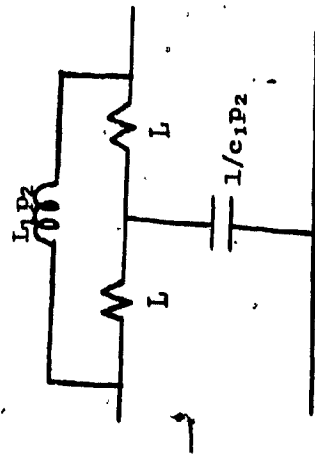
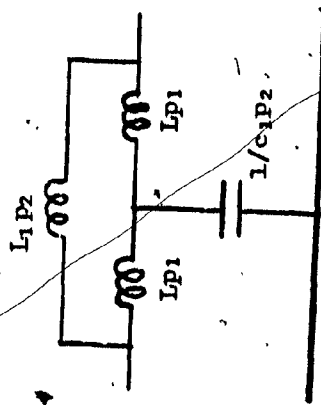

$$L_1 = c_1$$

$$L = l$$

Table 3.3-1 Symmetrical Bridged-T Networks in Two Variables and Constant Resistance in One Variable.

(11) If $Z_{11}(p_1, 1)$ and $Z_{11}(1, p_2)$ does not have pole at origin in p_1 or p_2 plane than the reactance will be replaced by inductance of value R in the required plane.

3.6 EXAMPLES

Synthesize the following given $Z_{11}(p_1, p_2)$ and $Z_{12}(p_1, p_2)$ as a constant resistance:

$$(1) \quad Z_{11}(p_1, p_2) = \frac{p_2 + .5p_1 + 4p_1^2 p_2^2 + p_1^2 p_2}{2p_1 p_2 + .5p_1^2}$$

and

$$Z_{12}(p_1, p_2) = \frac{p_2 + p_2 p_1^2 + 4p_1^2 p_1}{2p_1 p_2 + .5p_1^2}$$

$$(2) \quad Z_{11}(p_1, p_2) = \frac{p_1 + .5p_2 + p_1 p_2^2 + 4p_1^2 p_2^2}{2p_1 p_2 + 0.5}$$

and

$$Z_{12}(p_1, p_2) = \frac{-[4p_1^2 p_2 + p_1 + p_1 p_2^2]}{2p_1 p_2 + .5}$$

Solution:

1. Using the earlier techniques developed for the synthesis of constant resistance bridged-T networks, the networks corresponding to (1) and (2) are shown in Fig. 3.5-1 and 3.5-2 respectively.

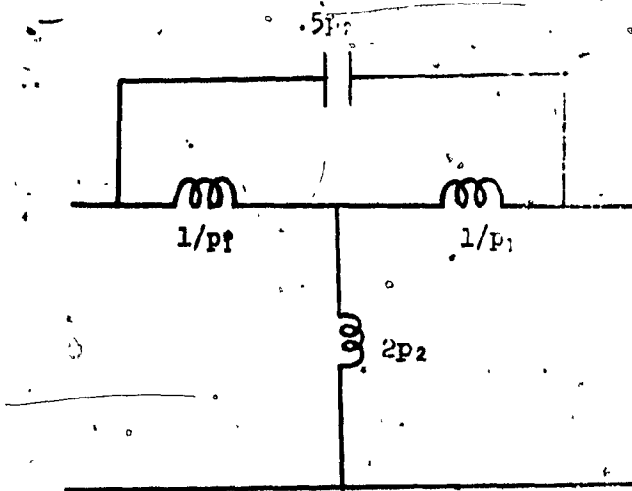

Two Variable

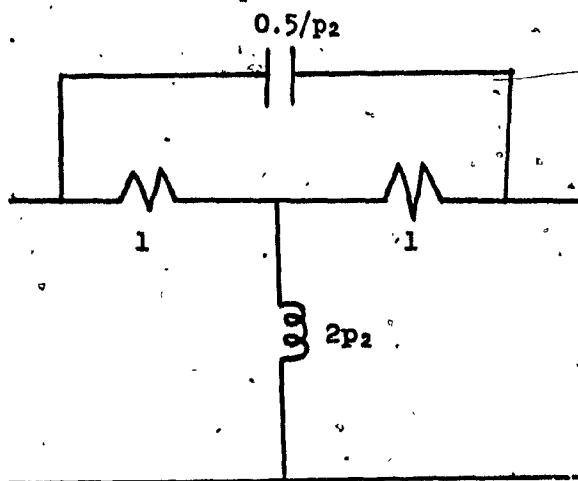

Single variable in "p₂"

Fig. 3.5-1

Two variable and one variable bridged-T networks of the Example Problem 1.

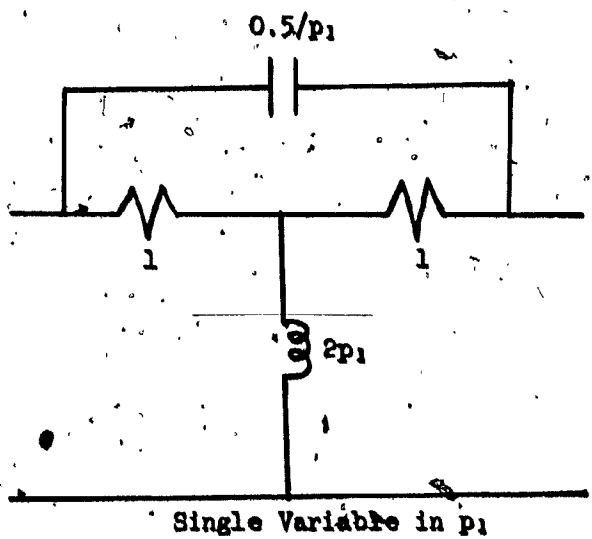
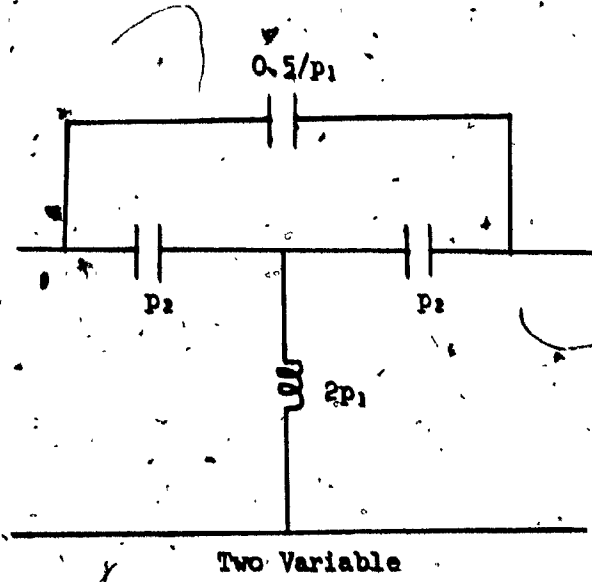

Fig. 3.5-2

Two Variable and One Variable Bridged-T Networks of
The Example Problem 2.

3.7 SUMMARY AND DISCUSSION

From this study, it can be concluded that the two-variable bridge-T reactance network cannot constitute a constant-resistance network. However, only a subclass of two-variable bridge-T network can become a constant-resistance single-variable bridge-T when the other variable is put equal to unity. The properties of the various bridged-T networks having one element in an impedance arm have been studied.

PART IV

CONCLUSION

This report has considered the possibility of realizing a certain class of two variable symmetrical lattice and bridged-T structures.

From the study of the symmetrical lattice it has been found that when z_a and z_b are functions of one variable only, the lattice cannot constitute a constant resistance network. However, if each is a function of both variables, the lattice can constitute a constant resistance network. This class of lattice has been divided into four categories, namely SL_1 , SL_2 , SL_3 and SL_4 .

It is shown in the report that the categories SL_1 and SL_2 can constitute constant reactance symmetrical lattice in two variables but SL_3 and SL_4 cannot.

Also it is observed that if Z_{11} and Z_{12} meets the conditions for SL_1 , they will meet the conditions for SL_2 but for phase reversal only. But on the other hand, if they meet the conditions set for SL_3 or SL_4 , they will not meet any other set of specifications.

From the study of bridged-T networks in two variables, it is concluded that it cannot constitute a constant resistance network. However, only a subclass of two variable bridged-T networks can become a constant resistance-single variable bridged-T when the other variable

is made equal to unity. The properties of the various bridged-T networks having one element in an impedance arm have been studied and the method of realization of such networks is enunciated.

REFERENCES

1. M. E. Valkenburg. Introduction to Modern Network Synthesis. John Wiley and Sons, Inc.
2. A. S. Rao. "The Real Part of a Multivariable Positive Real Function and the Synthesis of Multivariable Ladder Networks", D. Eng. Thesis, at Sir George Williams University (now Concordia University), Montreal, Canada, December 1973.
3. V. Ramachandran. "Some Similarities and Dissimilarities Between Single Variable and Two Variable Reactance Functions," IEEE Transactions; Circuits and Systems Newsletter, pp. 11-14, Feb. 1976.
4. H. B. Lee. "A New Canonic Realization Procedure", IEEE Trans. on Circuit Theory. Vol. CT10, pp. 81-83, March 1963.
5. ———. "An Additional Realization Cycle for LC Impedances", IEEE Trans. on Circuit Theory. Vol. CT. 12, pp. 435-437, September 1965.
6. Tukuran Kida. "On Minimum Element Synthesis of a Reactance Function by Cascade Connection of Non-Symmetric Lattice Sections", Electronics and Communications in Japan. Vol. 56-A, No. 4, pp. 7-13, Feb. 1973.
7. V. Ramachandran and M. N. S. Swamy. "A New Canonic Realization of Lossless Immittance Functions Using Six-Element Sections", International Journal of Circuit Theory and Applications. Vol. 4, pp. 43-53, January 1976.
8. Henry G. Ansell. "On Certain Two Variable Generalizations of Circuit Theory with Applications to Networks of Transmission Lines and Lumped Reactances", IEEE Trans. on Circuit Theory. Vol. CT-11, No. 2, pp. 214-233, June 1974.
9. T. Koga. "Synthesis of Passive n-ports with prescribed two variable Reactance matrices", IEEE Trans. on Circuit Theory, Vol. CT-13, No. 1, pp. 31-52, March 1966.

10. A. S. Rao and V. Ramachandran. "Canonic Realization of Some Two-Variable Reactance Functions", Alter Frequenze, Vol. XLIII, No. 3, pp. 189-133E, 1974.
11. T. N. Rao. "Minimal Synthesis of Two-Variable Reactance Matrices", Bell System Tech. Journal, Vol. 48, No. 1, pp. 163-119, January 1969.
12. V. Ramachandran, M.N.S. Swamy, C.H. Reddy. "On the Foster Form Decomposition of a Class of Multivariable Reactance Functions", presented at the 18th Midwest Symposium on Circuit-Theory, Concordia University, Montreal, August 1975.
13. A. M. Soliman and N. K. Bose. "A Decomposition Theorem for the Multi-variable Reactance Functions", Proc. IEEE, pp. 309-311, February 1971.
14. N. K. Bose. "An Algorithm for Synthesis of a Class of Multivariable Positive Real Functions", Proc. IEEE, pp. 1615-1616, November 1974.
15. V. Ramachandran, C.H. Reddy and M. N. S. Swamy. "Some Theorems on Sum Separability of Multivariable Reactance and Positive Real Functions." Accepted for publication in Journal of Franklin Institute.
16. F. K. Bishara. Foster Form Realizations of a Class of Two-Variable Reactance Functions. M. Eng. Report at Concordia University, Montreal, Canada.