

DESIGN OF AN AUTOMATICALLY SEQUENCED  
VACUUM PUMPING SYSTEM

DHARAPURAM PALANIAPPA MURUGESAN

A DISSERTATION  
in the  
Faculty of Engineering

Presented in partial fulfilment of the requirements for  
the Degree of Master of Engineering at  
Concordia University  
Montreal, Canada

December 1976

## TABLE OF CONTENTS

LIST OF TABLES	vi
LIST OF FIGURES	ix
ACKNOWLEDGEMENTS	xiv
ABSTRACT	xv
1. INTRODUCTION	
1.1 MANUAL VACUUM PUMPING SYSTEM	1
1.2 BASIC SEQUENCES OF OPERATION OF A MANUAL VACUUM PUMPING SYSTEM	3
1.3 JUSTIFICATION FOR AN AUTOMATIC VACUUM SYSTEM	10
1.4 AIM	12
2. BASIC SEQUENCES OF OPERATION OF AN AUTOMATIC VACUUM PUMPING SYSTEM	
2.1 START-UP	13
2.2 INTERMEDIATE OPERATION	15
2.3 WORK COMPLETION	15
2.4 NEXT CYCLE	17
2.5 SHUT-DOWN	17
2.6 ADVANTAGES OF AN AUTOMATIC SYSTEM OVER A MANUAL SYSTEM	19
2.7 COMPARISON	19

3.	DETAILED DESCRIPTION OF OPERATION AND DESIGN OF THE AUTOMATIC PUMPING SYSTEM	
3.1	CIRCUIT DIAGRAM	28
3.2	MAINS SUPPLY	28
3.3	ROTARY PUMP	28
3.4	PIRANI GAUGE, VACUUM SWITCHES, ISOLATION/AIR ADMITTANCE AND WATER FLOW VALVES	33
3.5	TIMER	37
3.6	TO OPEN(ENERGIZE) THE BACKING VALVE	42
3.7	DIFFUSION PUMP	63
3.8	TO OPEN(ENERGIZE) THE ROUGHING VALVE	64
3.9	ALARM BELL	74
3.10	READY LIGHT	78
3.11	COOL-DOWN	80
3.12	WARNING LIGHT	84
3.13	SHUT-DOWN	88
3.14	TO OPERATE THE ISOLATION/AIR ADMITTANCE VALVE	96
3.15	MODIFICATION OF MODEL B5 PIRANI GAUGE TO OPERATE TWO VS9 VACUUM SWITCHES	98
3.16	TIMER-CAM: DETAILS OF THE CAM DESIGN	105
4.	MAJOR HARDWARE SELECTION	
4.1	ROTARY PUMP	108

4.2	MAGNETICALLY OPERATED $\frac{1}{2}$ " ISOLATION/ AIR ADMITTANCE VALVE	111
4.3	BACKING AND ROUGHING VALVES	112
4.4	PIRANI VACUUM GAUGE	116
4.5	PIRANI GAUGE HEADS	117
4.6	VACUUM SWITCHES	117
4.7	DIFFUSION PUMP	119
4.8	HIGH VACUUM VALVE(BAFFLE VALVE)	122
4.9	CHAMBER AIR ADMITTANCE VALVE	124
4.10	VACUUM CONNECTIONS	124
4.11	TIMER	124
4.12	RELAYS	125
4.13	MICROSWITCHES	125
5.	EXPERIENCE WITH THE AUTOMATIC SYSTEM	
5.1	TO DELAY THE OPENING OF THE BACKING VALVE	127
5.2	TO DELAY THE OPENING OF THE ROUGHING VALVE	127
5.3	EXPERIMENT TO FIND OPENING AND CLOSING TIMES AGAINST APPLIED VOLTAGE FOR A $\frac{1}{2}$ INCH MAGNETIC VALVE	128
5.4	TESTING THE SEQUENCES OF OPERATION	134
6.	CONCLUSION	138
	REFERENCES	139

## LIST OF TABLES

Table 2.1	ADVANTAGES OF AN AUTOMATIC SYSTEM OVER MANUAL SYSTEM	20
Table 2.2	COMPARISON OF SAFETY PROTECTIONS, WARNINGS AND INDICATIONS BETWEEN THE AUTOMATIC AND THE MANUAL PUMPING SYSTEMS,	24
Table 3.1	TRUTH TABLE FOR THE ROTARY PUMP POWER	30
Table 3.2	TRUTH TABLE TO SWITCH POWER ON TO THE PIRANI GAUGE, VACUUM SWITCHES, WATER FLOW, ISOLATION AND AIR ADMITTANCE VALVES	36
Table 3.3	TRUTH TABLE TO SWITCH THE TIMER POWER ON	41
Table 3.4	TRUTH TABLE FOR THE STARTING CONDITION	47
Table 3.5	DETATLED TRUTH TABLE TO SHOW THE OPERATION OF THE BACKING VALVE FOR THE STARTING CONDITION	49
Table 3.6	TRUTH TABLE TO SHOW THE OPERATION OF THE BACKING VALVE: FOR THE INTERMEDIATE CONDITION	53

Table 3.7	BASIC TRUTH TABLE FOR THE STARTING AND THE INTERMEDIATE CONDITIONS COMBINED	57
Table 3.8	TRUTH TABLE TO OPEN THE BACKING VALVE FOR STARTING AND INTERMEDIATE CONDITIONS COMBINED	60
Table 3.9	TRUTH TABLE TO SWITCH THE DIFFUSION PUMP HEATER ON	66
Table 3.10	TRUTH TABLE FOR THE OPERATION OF THE ROUGHING VALVE	72
Table 3.11	TRUTH TABLE FOR THE ALARM BELL OPERATION: WHEN THE HVV IS OPENED	77
Table 3.12	TRUTH TABLE FOR THE "READY" LIGHT POWER "ON"	82
Table 3.13	TRUTH TABLE SHOWING THE COOL-DOWN SWITCH OPERATION	86
Table 3.14	TRUTH TABLE FOR THE WARNING LIGHT OPERATION	90
Table 3.15	BASIC TRUTH TABLE TO SHUT-DOWN THE ROTARY PUMP	94
Table 3.16	DETAILED TRUTH TABLE TO SHUT-DOWN THE ROTARY PUMP	94 <sup>a</sup>
Table 3.17	TRUTH TABLE FOR CLOSING THE ISOLATION VALVE	99

Table 3.18 TRUTH TABLE FOR THE OPENING  
OF THE AIR ADMITTANCE VALVE

100

LIST OF FIGURES

Fig. 1.1	SCHEMATIC OF A VACUUM PUMPING SYSTEM	2
Fig. 3.1	CIRCUIT DIAGRAM FOR AN AUTOMATIC VACUUM PUMPING SYSTEM	
Fig. 3.2	CIRCUIT DIAGRAM FOR THE ROTARY POWER ON	29
Fig. 3.3	LOGIC DIAGRAM FOR THE ROTARY PUMP POWER ON	32
Fig. 3.4	BLOCK CIRCUIT DIAGRAM TO SWITCH POWER ON TO THE PIRANI GAUGE, VACUUM SWITCHES, WATER FLOW, ISOLATION AND AIR ADMITTANCE VALVES	34
Fig. 3.5	CIRCUIT DIAGRAM TO SWITCH POWER ON TO THE PIRANI GAUGE, VACUUM SWITCHES, WATER FLOW, ISOLATION AND AIR ADMITTANCE VALVES	35
Fig. 3.6	LOGIC DIAGRAM TO SWITCH POWER ON TO THE PIRANI GAUGE, VACUUM SWITCHES, WATER FLOW, ISOLATION AND AIR ADMITTANCE VALVES	35
Fig. 3.7	DETAILED CIRCUIT DIAGRAM FOR THE TIMER	38
Fig. 3.8	BASIC CIRCUIT DIAGRAM TO START THE TIMER	40



Fig. 3.9	LOGIC CIRCUIT FOR THE TIMER POWER ON	41
Fig. 3.10	DETAILED CIRCUIT DIAGRAM TO OPEN THE BACKING VALVE	43
Fig. 3.11	BASIC CIRCUIT DIAGRAM TO OPEN THE BACKING VALVE: FOR THE STARTING CONDITION	46
Fig. 3.12	LOGIC DIAGRAM TO OPEN THE BACKING VALVE: FOR THE STARTING CONDITION	47
Fig. 3.13	DETAILED CIRCUIT TO OPEN THE BACKING VALVE: FOR THE STARTING CONDITION	48
Fig. 3.14	DETAILED LOGIC DIAGRAM TO OPEN THE BACKING VALVE: FOR THE STARTING CONDITION	50
Fig. 3.15	SIMPLIFIED CIRCUIT DIAGRAM TO OPEN THE BACKING VALVE: THE INTERMEDIATE CONDITION	52
Fig. 3.16	DETAILED CIRCUIT DIAGRAM TO OPEN THE BACKING VALVE: THE INTERMEDIATE CONDITION	52
Fig. 3.17	DETAILED LOGIC DIAGRAM TO OPEN THE BACKING VALVE: THE INTERMEDIATE CONDITION	55
Fig. 3.18	BASIC CIRCUIT DIAGRAM TO OPEN THE BACKING VALVE: FOR THE STARTING AND THE INTERMEDIATE CONDITIONS COMBINED	56

Fig. 3.19	BASIC LOGIC DIAGRAM TO OPEN THE BACKING VALVE FOR THE STARTING AND THE INTERMEDIATE CONDITIONS COMBINED	58
Fig. 3.20	DETAILED CIRCUIT DIAGRAM FOR THE BACKING VALVE: FOR THE STARTING AND THE INTERMEDIATE CONDITIONS COMBINED	59
Fig. 3.21	DETAILED LOGIC DIAGRAM TO OPEN THE BACKING VALVE FOR THE STARTING AND THE INTERMEDIATE CONDITIONS, COMBINED	62
Fig. 3.22	CIRCUIT DIAGRAM TO SWITCH ON THE DIFFUSION PUMP HEATER	65
Fig. 3.23	LOGIC DIAGRAM TO SWITCH THE DIFFUSION PUMP HEATER ON	66
Fig. 3.24	DETAILED CIRCUIT DIAGRAM TO OPERATE THE ROUGHING VALVE	68
Fig. 3.25	BASIC SWITCHING CIRCUIT FOR THE OPERATION OF THE ROUGHING VALVE	71
Fig. 3.26	DETAILED SWITCHING CIRCUIT FOR THE OPERATION OF THE ROUGHING VALVE	71
Fig. 3.27	LOGIC DIAGRAM SHOWING THE OPERATION OF THE ROUGHING VALVE	73
Fig. 3.28	CIRCUIT DIAGRAM TO OPERATE THE ALARM BELL	75

Fig. 3.29	LOGIC CIRCUIT DIAGRAM FOR THE ALARM BELL "OFF" CONDITION WHEN THE HIGH VACUUM VALVE IS OPENED	79
Fig. 3.30	CIRCUIT DIAGRAM FOR THE "READY" LIGHT POWER "ON"	81
Fig. 3.31	LOGIC DIAGRAM SHOWING THE "READY" LIGHT POWER "ON" CONDITION	83
Fig. 3.32	CIRCUIT DIAGRAM FOR THE COOL-DOWN SWITCH OPERATION	85
Fig. 3.33	LOGIC DIAGRAM SHOWING THE COOL-DOWN SWITCH OPERATION	87
Fig. 3.34	CIRCUIT DIAGRAM FOR THE WARNING LIGHT OPERATION	89
Fig. 3.35	LOGIC DIAGRAM FOR THE WARNING OPERATION	90
Fig. 3.36	CIRCUIT DIAGRAM FOR THE SHUT-DOWN OPERATION	92
Fig. 3.37	BASIC CIRCUIT DIAGRAM TO SHUT-DOWN THE ROTARY PUMP AND HENCE THE SYSTEM	93
Fig. 3.38	BASIC LOGIC DIAGRAM TO SHUT-DOWN THE ROTARY PUMP AND HENCE THE SYSTEM	95
Fig. 3.39	DETAILED LOGIC DIAGRAM TO SHUT-DOWN THE ROTARY PUMP	95
Fig. 3.40	CIRCUIT DIAGRAM FOR THE OPERATION OF THE ISOLATION/AIR ADMITTANCE VALVE	97

Fig. 3.41	LOGIC DIAGRAM FOR CLOSING THE ISOLATION VALVE	99
Fig. 3.42	LOGIC DIAGRAM TO OPEN THE AIR ADMITTANCE VALVE	100
Fig. 3.43	B5 PIRANI-CIRCUIT DIAGRAM	101
Fig. 3.44	CIRCUIT DIAGRAM SHOWING A PIRANI GAUGE IN THE WHEATSTONE BRIDGE NETWORK; FOR MODEL B5 GAUGE	102
Fig. 3.45	MODIFIED B5 GAUGE TO OPERATE TWO VACUUM SWITCHES	104
Fig. 3.46	CAM DESIGN	106
Fig. 3.47	TIMER AND CAM	106
Fig. 4.1	BASIC FEATURES OF A ROTARY PUMP	109
Fig. 4.2	DETAILED FEATURES OF A ROTARY PUMP	110
Fig. 4.3	DETAILS OF VALVE CONSTRUCTION	113
Fig. 4.4	$\frac{1}{2}$ INCH MAGNETIC ISOLATION VALVE	114
Fig. 4.5	MODELS G6A AND M6A PIRANI GAUGE HEADS	118
Fig. 4.6	VACUUM SWITCH VS9 FRONT PANEL	120
Fig. 4.7	VACUUM SWITCH VS9 REAR PANEL	121
Fig. 4.8	A SKETCH OF A DIFFUSION PUMP	123
Fig. 5.	SET-UP FOR A.C. SWITCHING; SET-UP FOR D.C. SWITCHING	131

### ACKNOWLEDGEMENTS

The author expresses his deep sense of gratitude to Professor V. Ramachandran for his guidance throughout this report.

The author thanks his wife for typing this report.

DESIGN OF AN AUTOMATICALLY SEQUENCED  
VACUUM PUMPING SYSTEM

DHARAPURAM PALANIAPPA MURUGESAN

ABSTRACT

The advantages of an automatic vacuum pumping system over a manual system are clearly shown. Safety protections, warnings and indications between the automatic and manual systems are compared. The system consists of rotary pump, magnetic isolation valves, diffusion pump, Pirani gauge, vacuum switches, high vacuum valve, timer, relays and microswitches.

A detailed description of the operation and design of the automatic pumping system is given. The sequences of operations are controlled by means of logic circuits. These have been tested and are found to agree with the design.

In addition, an experiment to measure the opening and the closing times of a magnetic isolation valve against input voltage was conducted and the significance of the results is discussed.

CHAPTER I

INTRODUCTION

CHAPTER I  
INTRODUCTION

1.1 MANUAL VACUUM PUMPING SYSTEM:

A vacuum pumping system is designed basically to produce vacuum in a work chamber. The vacuum system plays a very important role in the manufacture of radio and television tubes, lamps and x-ray equipment. It is also used in the development of atomic energy, thin film deposition, vacuum metallurgy, vacuum drying and so on.

A schematic of a typical vacuum pumping system is shown in Fig. (1.1). The system consists of a rotary pump to provide backing to a diffusion pump through the openings of isolation and backing valves. Pumping speed of the rotary pump is matched to the diffusion pump in order to avoid accumulation of air in the backing line. Since the diffusion pump requires a fore-vacuum to pump efficiently, the rotary pump roughs the work (vacuum) chamber first to the pre-required fore-vacuum through the roughing valve. The chamber is then evacuated by the diffusion pump by opening a high vacuum valve. A "Pirani" gauge is used to measure either the backing or the roughing vacuum. An air admittance valve is provided in the chamber to admit air in to it whenever required. When the rotary



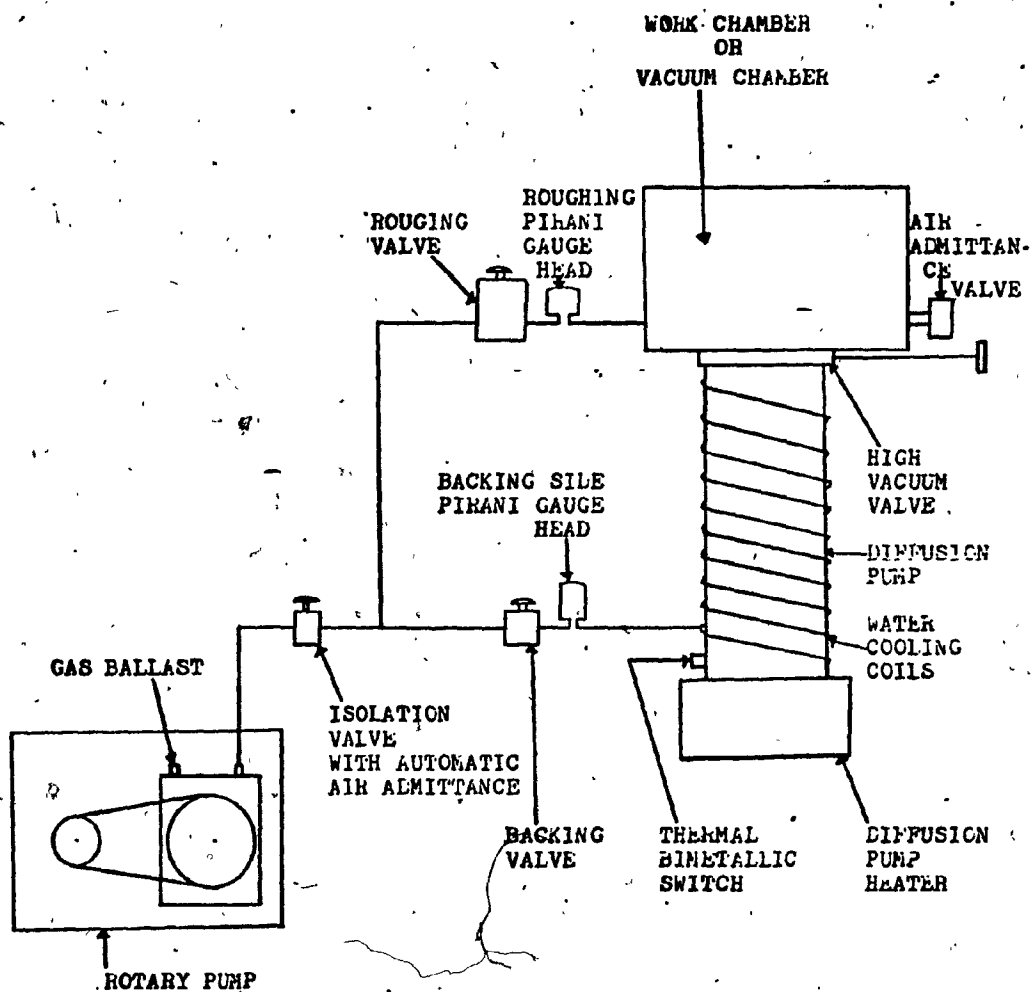

Fig. 1.1 SCHEMATIC OF A VACUUM PUMPING SYSTEM.

pump is switched off, the isolation valve closes and another built-in air admittance valve opens to admit air between the isolation valve and the rotary pump in order to equalize the pressures and thus to stop the rotary pump cooling oil from surging into the vacuum line.

1.2 BASIC SEQUENCES OF OPERATION OF A MANUAL VACUUM PUMPING SYSTEM:

There are five different stages of operation which are described as follows:

1.2.1 START - UP:

The following sequences shall be strictly adhered to:

- a) Turn on the water supply to the diffusion pump to cool the pump to condense the oil or mercury vapour for re-use.
- b) Start the rotary pump to back the diffusion pump. The isolation valve will open. The air admittance valve built-in to the isolation valve will close to prevent any air getting in.

- c) Switch on the Pirani gauge and select the backing head to measure the vacuum in the backing line.
- d) Open the backing valve about thirty seconds after the rotary pump is switched on so that the pipe between the rotary pump and the backing and the roughing valves is evacuated to preserve vacuum in the diffusion pump side.
- e) Switch on the diffusion pump heater when the vacuum in the backing line is about 0.08 torr (mm of mercury) in order to warm-up the diffusion pump. Read the vacuum in the backing line using the Pirani gauge.
- f) Close the backing valve to preserve the vacuum in the diffusion pump side.
- g) Open the roughing valve after about fifteen seconds to rough the chamber. This delay is required to ensure that the roughing valve opens only after the backing valve has closed so that there is no pressure link between the backing and the roughing sides.
- h) Close the roughing valve when the chamber reaches a suitable vacuum of 0.08 torr so that

the diffusion pump can pump the chamber efficiently. The vacuum is read by the Pirani gauge switched to the roughing head.

- 1) Open the backing valve after about ten seconds. This delay is required to ensure that the roughing valve is fully closed before the backing valve is opened.
- 2) Switch the Pirani gauge to the backing head and read the vacuum in the backing line.

#### 1.2.2 INTERMEDIATE OPERATION:

Before opening the high vacuum valve, recheck the vacuum in the chamber using the Pirani gauge switched to the roughing head. If the vacuum in the chamber becomes worse than 0.08 torr due to leaks or outgasing in the chamber or in the roughing line, then the diffusion pump cannot pump the chamber smoothly. Therefore, the vacuum in the chamber must be re-established to 0.08 torr or better by following the sequences described below:

- a) Close the backing valve to preserve the vacuum in the diffusion pump side.
- b) Open the roughing valve after about fifteen seconds to rough the chamber. The reason for the delay is given in 1.2.1.g.
- c) Close the roughing valve when the chamber vacuum is around 0.08 torr.
- d) Open the backing valve to back the diffusion pump. Switch the Pirani gauge to the backing head to read the backing pressure.

1.2.3 WORK COMPLETION:

The diffusion pump is fully warmed-up eight minutes after being switched on. As a further precaution, switch the Pirani gauge to the roughing head and recheck the chamber vacuum. If the chamber vacuum is better than 0.08 torr, the required work can be proceeded by following the sequences given below:

- a) Open the high vacuum valve so that the chamber is evacuated by the diffusion pump.

- 7
- b) Close the high vacuum valve to perform the required operation when the chamber reaches a required vacuum, say 0.001 torr, as measured by the Pirani gauge switched to the roughing head.
  - c) Perform the required operation, such as coating etc., in the chamber.
  - d) Open the chamber air admittance valve after completion of the work to admit air in to the chamber.
  - e) Remove the chamber glass and the finished work pieces and proceed with the next cycle.

#### 1.2.4 NEXT CYCLE:

Place another set of work pieces in the chamber. To carry out the next cycle of operation the following sequences shall be followed:

- a) Close the chamber air admittance valve in order to evacuate the chamber.
- b) Close the backing valve to preserve the vacuum

in the diffusion pump side.

- c) Open the roughing valve after about fifteen seconds delay to rough the chamber.
- d) Close the roughing valve when the vacuum in the chamber is about 0.08 torr.
- e) Open the backing valve after about ten seconds so that the rotary pump can back the diffusion pump.
- f) Follow the sequences 1.2.3.a to 1.2.3.e to complete the next cycle of operation.

#### 1.2.5 SHUT - DOWN:

After all the work is completed or at the end of the day, it will be required to shut down the system. The following sequences shall be followed for shut-down:

- a) Ensure that the high vacuum valve is closed and the chamber air admittance valve is opened in order to remove the chamber glass cover whenever required.

- 9
- b) Switch off the diffusion pump heater since the pump is no longer required to evacuate the chamber.
  - c) Switch off the backing valve approximately twenty minutes after the diffusion pump heater is switched off. During the twenty minutes interval, the diffusion pump has cooled down completely and will not require the rotary pump for backing.
  - d) Switch off the rotary pump approximately thirty seconds after the backing valve is switched off.

The isolation valve will close and isolate the diffusion pump from the rotary pump. The air admittance valve will open to admit air in to the rotary pump side in order to equalize the pressures and thus to prevent the rotary pump oil from surging in to the vacuum line.

It is desirable sometimes to keep the diffusion pump side under vacuum in order to speed up the operation next day. To achieve this, a delay of about thirty seconds is necessary to ensure that the backing valve is



fully closed before the air admittance valve opens.

Note: If it is not necessary to keep the diffusion pump side under vacuum, no delay is required. The rotary pump can be switched off as soon as the backing valve is switched off.

- e) Switch off the Pirani gauge since no vacuum measurement will be carried out.
- f) Turn off the water supply to the diffusion pump since no more cooling will be required.

Thus, by following the above five different stages of operation manually, the required work can be performed.

### 1.3 JUSTIFICATION FOR AN AUTOMATIC VACUUM SYSTEM:

As mentioned earlier, vacuum systems are employed for many scientific and commercial applications, such as manufacture of vacuum tubes, thin film deposition of metals etc.. In nearly all these applications, operator errors are costly and unacceptable.

Manually operated vacuum system is subject to many costly human errors. One of the commonest errors, for example, is the failure to turn on the water supply to the diffusion pump before switching the diffusion pump heater supply on. Basically, water is circulated around the outer circumference of the diffusion pump through coils to cool the pump to condense the mercury or oil vapour for re-use and to extend the operating life of the pump. If the diffusion pump heater is switched on without turning the water supply on, the pump loses all the evaporated mercury or oil in to the atmosphere quickly before the built-in protective bimetallic relay disconnects the diffusion pump.

Another major handicap in the manual system is that the high vacuum valve can be opened manually, without any warning signal, even when there is insufficient vacuum in the chamber. This will affect the smooth operation of the diffusion pump due to lack of sufficient vacuum in the backing line and the mercury or oil fumes will foul up the chamber. For example, in the thin film deposition work, there is a danger of damaging the work pieces in the chamber by applying the coating material at incorrect vacuum. Besides, a sincere and technically trained worker is required full-time for the successful operation of a manual system.

Considering all the above and other difficulties, an automatic system, which will eliminate the costly human

errors and is simple to operate, is justified.

1.4 AIM:

The aim of the work is to

- a) design an automatic vacuum pumping system,
- b) select suitable major components, and
- c) describe the experiences with the system.

CHAPTER II

BASIC SEQUENCES OF OPERATION OF AN  
AUTOMATIC VACUUM PUMPING SYSTEM

## CHAPTER II

### BASIC SEQUENCES OF OPERATION OF AN AUTOMATIC VACUUM PUMPING SYSTEM

There are five different stages of operation which are described below:

#### 2.1 START - UP:

When the rotary pump is switched on manually, the following sequences occur automatically:

- a) The water flow and the isolation valves open.
- b) The air admittance valve built-in to the isolation valve closes.
- c) The Pirani gauge and the two vacuum switches switch on. The vacuum switches are used to control certain operations at pre-determined vacuum.
- d) A timer switches itself on. A half an hour per one revolution timer is employed to control the sequences of operation at pre-determined intervals.
- e) The backing valve opens with a delay to allow the rotary pump to evacuate the rotary side

first and thus to protect the vacuum in the diffusion pump side.

- f) The diffusion pump heater switches itself on when the vacuum in the backing line is about 0.08 torr.
- g) The backing valve closes.
- h) Then, the roughing valve opens. The reason for this delay is explained in section 1.2.1.g.
- i) The roughing valve closes when the vacuum in the chamber is about 0.08 torr.
- j) Then, the backing valve opens.
- k) The timer switches itself OFF after about eight minutes.
- l) A "Ready" bulb lights when the chamber vacuum is about 0.08 torr to indicate that the high vacuum valve can be opened manually without upsetting the vacuum system.

## 2.2 INTERMEDIATE OPERATION:

When the chamber vacuum gets worse than 0.08 torr due to leaks or outgassing in the chamber or in the roughing line, the "Ready" light will switch "OFF". In order to re-establish the required vacuum in the chamber, the following sequences occur automatically:

- a) The backing valve closes when the vacuum in the chamber is worse than 0.08 torr. The roughing vacuum switch is preset to close the backing valve when the chamber vacuum is worse than 0.08 torr in order to evacuate the chamber.
- b) Then, the roughing valve opens.
- c) The roughing valve closes when the chamber vacuum reaches 0.08 torr.
- d) Then, the backing valve opens.
- e) The "Ready" light comes "on" again.

## 2.3 WORK COMPLETION:

In order to complete the work, the following

sequences shall be followed:

- a) The high vacuum valve is opened manually, when the "Ready" light is ON, in order to allow the diffusion pump to evacuate the chamber.
- b) The high vacuum valve is closed manually when the chamber has reached a desired vacuum, say 0.001 torr, as read by the Pirani gauge switched to the roughing head.
- c) The required work, such as thin film deposition, is performed on the work pieces.
- d) The chamber air admittance valve is opened manually to admit air into the chamber when the required work is completed. This enables to remove the glass chamber and the finished work pieces and then to place the new pieces for the next cycle of operation.
- e) Then the chamber air admittance valve is closed manually and the glass chamber is placed in position.



#### 2.4 NEXT CYCLE:

To complete the next cycle of operation, the following sequences occur automatically:

- a) The backing valve closes to preserve the vacuum in the diffusion pump side.
- b) Then, the roughing valve opens and the rotary pump evacuates the chamber.
- c) The roughing valve closes when the chamber vacuum reaches 0.08 torr.
- d) Then, the backing valve opens.
- e) The "READY" light comes on.
- f) Then, the "WORK COMPLETION" sequences 2.3.a. to 2.3.e. are followed to complete the cycle.

#### 2.5 SHUT-DOWN:

The vacuum system will have to be shut-down either after completion of all the work or at the end of the day. In order to shut down the system, a spring-loaded cool-down switch is pressed manually.

Then the following sequences occur automatically:

- a) The timer switches itself on. This enables to shut-down the system after a pre-determined interval.
- b) The diffusion pump heater switches itself OFF to start the cool-down.
- c) The "READY" light goes OFF to indicate the start of the cool-down period.
- d) A warning light comes "ON" to warn the operator not to open the high vacuum valve during the cool-down period. If the operator attempts to open the high vacuum valve an alarm bell will ring to give him a warning to close the valve.
- e) The rotary pump stops after about twenty two minutes since the power to the pump is switched off by a timer-cam-relay arrangement.
- f) The isolation, the backing and the water flow valves close; the Pirani gauge and the vacuum switches switch off; the timer stops and all the indications and warning lights switch off since they are all connected

across the rotary pump power which is switched off in step (e).

- g) The air admittance valve built-in the isolation valve opens to admit air into the rotary pump side to equalize the pressures in order to prevent the rotary pump oil from surging out into the vacuum line.

The whole system is thus shut-down.

## 2.6 ADVANTAGES OF AN AUTOMATIC SYSTEM OVER A MANUAL SYSTEM:

Table 2.1 shows the details of the various advantages obtained by employing an automatic system for the above operations.

## 2.7 COMPARISON:

Table 2.2 shows a comparison of safety protections, warnings and indications between the automatic and manual pumping systems.

A detailed study of the tables-2.1 and 2.2 should convince the designer that the automatic operation is vastly superior to the manual operation.

TABLE 2.1ADVANTAGES OF AN AUTOMATIC SYSTEM OVER MANUAL SYSTEM

Item No.	DESCRIPTION	MODE OF OPERATION	
		Automatic System	Manual System
	<u>START-UP:</u>		
a)	The water flow valve is opened	Automatically	Manually
b)	The Pirani gauge is switched on	"	"
c)	The vacuum switches are on	"	There are no vacuum switches.
d)	The timer switches on	"	There is no timer.
e)	The backing valve is opened	Automatically with a pre-determined delay using thermistors.	Manually. The delay is determined manually.
f)	The diffusion pump is switched on when the vacuum in the backing line is 0.08 torr	Automatically	Manually
g)	The backing valve is closed.	"	"
h)	Then, the roughing valve is opened	"	"
i)	When the chamber reaches a suitable vacuum of approximately 0.08 torr, the roughing valve is closed	"	"

TABLE 2.1 CONTINUED

Item No.	DESCRIPTION	MODE OF OPERATION	
		Automatic System	Manual System
j)	Then, the backing valve is opened	Automatically	Manually
	<u>INTERMEDIATE OPERATION:</u>		
k)	If the chamber vacuum gets worse than 0.08 torr for any reason, say, due to leaks, the backing valve is closed	"	"
l)	Then, the roughing valve is opened to rough the chamber	"	"
m)	When the chamber vacuum has reached 0.08 torr again, the roughing valve is closed	"	"
n)	Then, the backing valve is opened	"	"
	<u>WORK COMPLETION:</u>		
o)	The diffusion pump warm-up period is	pre-determined automatically by the timer-cam-micro-switch arrangement. <u>8</u> minutes.	Judged manually.

TABLE 2.1 CONTINUED

Item No.	DESCRIPTION	MODE OF OPERATION	
		Automatic System	Manual System
p)	When the diffusion pump is warmed-up for about eight minutes and when the chamber vacuum is around 0.08 torr, the high vacuum valve is opened	Manually, but only when the "ready" bulb is on.	Manually, but there is no "Ready" bulb.
q)	If an attempt is made to open the high vacuum valve before the "Ready" light comes ON, an alarm bell rings  <u>SHUT-DOWN:</u>	Automatically	There is no alarm bell.
r)	The diffusion pump heater is switched off	Automatically by pressing a cool-down switch.	Manually. There is no cool-down switch.
s)	During cool-down, a warning light to warn the operator not to open the high vacuum valve	Comes on automatically	No such warning light.
t)	The diffusion pump cooling period is	Pre-determined automatically by a timer-cam-micro-switch arrangement  ( <u>22</u> minutes)	Judged manually.

TABLE 2.1 CONTINUED

Item No.	DESCRIPTION	MODE OF OPERATION	
		Automatic System	Manual System
u)	The rotary pump is switched off.	Automatically after twenty two minutes by the timer-cam-micro-switch arrangement.	Manually. No fixed time interval; decided by the operator.
v)	The water flow and the backing valves are closed	Automatically	Manually
w)	The Pirani gauge is switched off	"	"
x)	The vacuum switches are switched off	"	As mentioned before, there are no vacuum switches.

TABLE 2.2

COMPARISON OF SAFETY PROTECTIONS, WARNINGS AND INDICATIONS  
BETWEEN THE AUTOMATIC AND THE MANUAL PUMPING SYSTEMS

Item No.	For Automatic System	For Manual System
	<u>ELECTRICAL PROTECTION:</u>	
a)	A 13 Amp fuse protects the whole circuit in case of electrical failure.	The same.
b)	A built-in overload relay in the rotary pump starter protects the pump and other associated electrical components.	The same.
c)	A 5 Amp fuse protects the diffusion pump heater and the electrical alarm bell.	The 13 Amp mains fuse protects the diffusion heater. There is no alarm bell.
d)	A 3 Amp fuse protects the backing, roughing and water flow valves, the Pirani gauge, the vacuum switches, the d.c. relays and the timer. Besides, in the case of Pirani gauge, a built-in fuse provides additional protection.	The 13 Amp mains fuse protects the backing and the roughing valves and the Pirani gauge.
	<u>WATER SUPPLY PROTECTION:</u>	
e)	The water supply is on automatically when the rotary pump is on and remains on till the rotary pump switches itself off at the end of the cool-down period.	The water supply is turned on manually and hence the system is subject to human error. The diffusion pump heater is connected



TABLE 2.2 CONTINUED

Item No.	For Automatic System	For Manual System
	<p>Thus, the water supply is on all the time during the operation to protect the diffusion pump.</p>	<p>through a bimetallic thermal switch which is fixed to the diffusion pump outer case. If the water supply is off for sometime, all the mercury or oil vapour will escape to atmosphere before the bimetallic relay trips due to hot outer case, and disconnects the heater supply.</p>
	<p><u>VACUUM PROTECTION:</u></p>	
f)	<p>The diffusion pump heater cannot be on until the vacuum in the backing line is about 0.08 torr. This protects the operation of the diffusion pump.</p>	<p>No such protection.</p>
g)	<p>The roughing valve cannot open when the air admittance valve is opened.</p>	
h)	<p>The roughing valve cannot open when the high vacuum valve is opened.</p>	
i)	<p>The roughing valve will open only after the backing valve has closed.</p>	
j)	<p>The backing and the roughing valves will never open at the same time.</p>	

TABLE 2.2 CONTINUED

Item No.	For Automatic System	For Manual System
k)	The backing and the roughing valves will never close at the same time, when the system is ON.	No such protection.
l)	A "Ready" light comes on when the chamber is ready to be pumped by the diffusion pump.	
m)	During the cool-down period, when the diffusion pump heater is off, the rotary pump backs the diffusion pump. Diffusion and rotary pumps cannot be switched off simultaneously.	No such protection. Rotary pump can be switched off when the diffusion pump is hot, even though the diffusion pump heater is switched off. Both pumps can be switched off simultaneously.
n)	The backing valve must open during the cool-down period.	No such protection.
o)	The roughing valve cannot open during the cool-down period.	No such protection.
<u>WARNINGS:</u>		
p)	An electrical alarm bell rings to warn the operator of a malfunction if the high vacuum valve is opened when the "Ready" bulb does not light.	No such protection.
q)	A Warning bulb lights to warn the operator that the high vacuum valve must not be opened during the cool-down period.	

TABLE 2.2 CONTINUED

Item No.	For Automatic System	For Manual System
	<u>INDICATIONS:</u>	
r)	A "red" bulb lights when the rotary pump is ON.	Normally available.
s)	A red bulb lights when the gauge and the switches are on.	Not available.
t)	A red bulb lights when the water flow valve is ON.	
u)	A red bulb lights when the backing valve is ON.	
v)	A red bulb lights when the timer is ON.	No timer.
w)	A red bulb lights when the roughing valve is ON.	Not available.
x)	A red bulb lights when the diffusion pump is ON.	Normally available.

CHAPTER III

DETAILED DESCRIPTION OF OPERATION AND  
DESIGN OF THE AUTOMATIC PUMPING SYSTEM

## CHAPTER III

### DETAILED DESCRIPTION OF OPERATION AND DESIGN OF THE AUTOMATIC PUMPING SYSTEM

#### 3.1 CIRCUIT DIAGRAM:

A complete circuit diagram of an automatic pumping system is shown in Fig. 3.1. The design of the operation of the various parts of the system are also described.

#### 3.2 MAINS SUPPLY:

The electrical supply to the circuit is both directly from the mains and through the rotary pump starter, which in turn, is driven by the same mains supply. The mains switch is normally left ON.

#### 3.3 ROTARY PUMP:

When the starter is switched on, the rotary pump starts through an overload relay and a relay contact RLD1.

The circuit diagram for the rotary pump power is shown in Fig. 3.2 and refers to section 1 of the complete circuit diagram, Fig. 3.1.

Table 3.1. gives the truth table for the switching on of the rotary pump power.

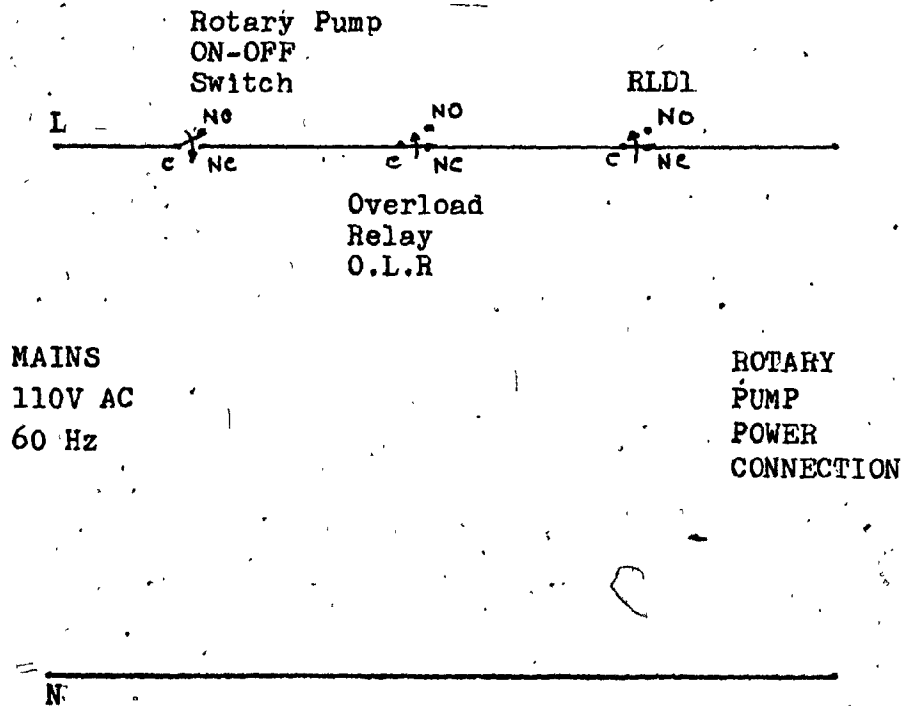

Fig. 3.2 CIRCUIT DIAGRAM FOR THE  
ROTARY POWER ON.

TABLE 3.1

TRUTH TABLE FOR THE ROTARY PUMP POWER

ON-OFF SWITCH	Overload relay(O.L.R)	R.L.D.1	R.P.P.
0	0	0	0
0	0	1	0
0	1	0	0
.	.	.	0
.	.	.	0
.	.	.	0
.	.	.	0
.	.	.	0
.	.	.	0
.	.	.	0
1	1	1	1

DESIRED "ON"  
CONDITION.

In constructing the truth tables in this report, the following conventions are followed:

1 = True = Power ON = ON = relay contact "Normally Closed" = valve energized to open.

'1' is represented with no bar on top of the item. eg. R.P.P = rotary pump power ON.

0 = False = Power OFF = OFF = relay contact "Normally Open" = valve not energized and closed.

'0' is represented with a bar on top of the item. eg.  $\overline{\text{R.P.P}}$  = rotary pump power OFF.

As shown in the truth table 3.1, the rotary pump power ON condition is uniquely determined when the ON-OFF switch is ON, the overload relay (OLR) and the relay RLD1 contacts are closed.

Thus, the logic equation for the rotary pump power ON is

$$\begin{aligned} \text{R.P.P} &= \text{ON-OFF switch ON} \cdot \text{OLR closed} \cdot \text{RLD1 closed} \\ &= \text{ON-OFF switch} \cdot \text{OLR} \cdot \text{RLD1} \end{aligned}$$





(Note: No bar on top of the items to represent the closed conditions.)

$$1 = 1 \cdot 1 \cdot 1$$

which leads to the following logic circuit diagram shown in Fig. 3.3. (It should be noted that such logic circuits are not shown in the main diagram Fig. 3.1).



In constructing the logic diagrams in this report, the following conventions are followed:

- a)  represents the change of state. ie. from "OFF" state to "ON" state and vice versa; eg.  $\frac{\overline{\text{ON-OFF}}}{\text{switch}}$    $\frac{\text{ON-OFF}}{\text{Switch}}$  represents that the switch changed from the "OFF" state to the "ON" state.
- b)  represents an AND circuit.
- c)  represents an OR circuit, and
- d)  represents equivalence. eg.  $\frac{\text{R.P.}}{\text{B5 VS9}}$  represents that when the rotary pump (R.P) is switched on, the B(5), VS9 etc, are also switched on.

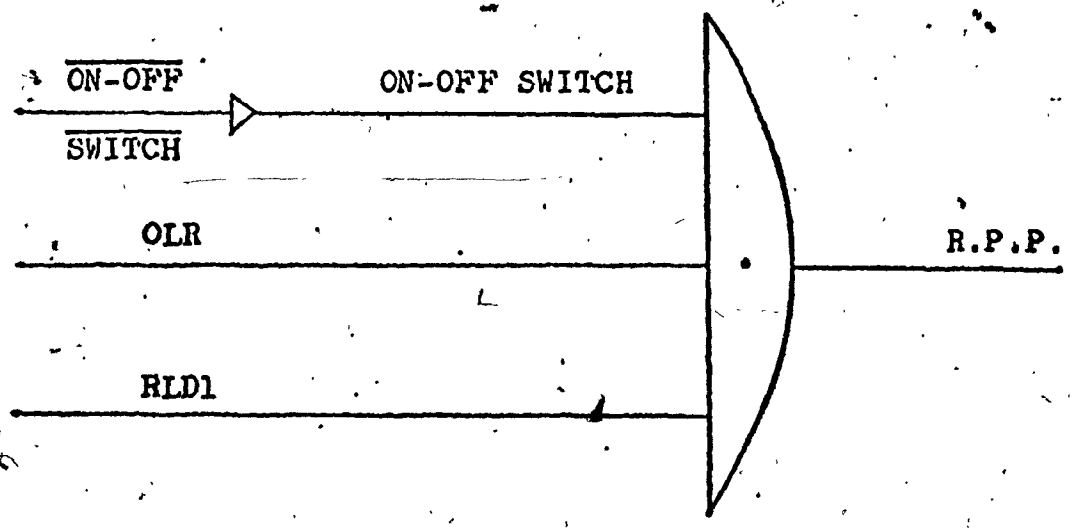

FIG. 3.3 LOGIC DIAGRAM FOR THE ROTARY PUMP  
POWER ON

### 3.4 PIRANI GAUGE, VACUUM SWITCHES, ISOLATION/AIR ADMITTANCE AND WATER FLOW VALVES:

When the rotary pump power is ON, the isolation valve opens and the built-in air-admittance valve closes, the water flow valve opens, the Pirani gauge, B5, and the two vacuum switches, VS9B and VS9R, are ON because all of them are connected to the rotary pump power supply, as shown in Fig. 3.4. When the Pirani gauge is ON, either the backing or the roughing head can be selected by the switches built-in the Pirani gauge unit to read the corresponding vacuum.

The basic circuit diagram to switch the power ON for the above components is shown in Fig. 3.5 and refers to section 2 of the complete circuit diagram, Fig. 3.1.

Table 3.2 gives the truth table for switching the power ON for the above components and leads to the following logic equations:

$$R.P = B5(B) = VS9B = VS9R = WFV = IV = \overline{AAV}$$

or

$$R.P = B5(R) = VS9B = VS9R = WFV = IV = \overline{AAV}$$

The corresponding logic circuit is shown in Fig. 3.6.

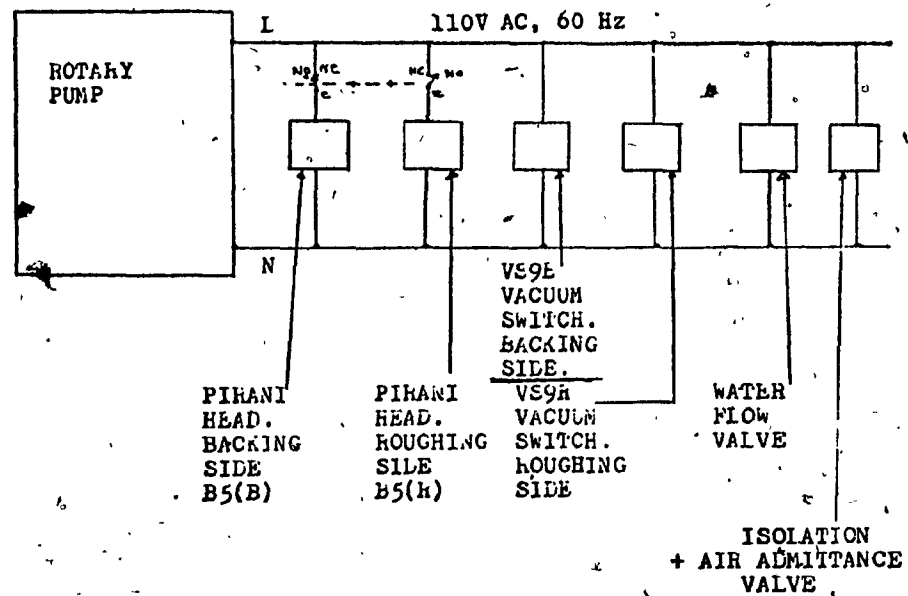

Fig. 3.4 Block circuit diagram to switch power ON to the Pirani gauge, vacuum switches, water flow, isolation and air admittance valves.

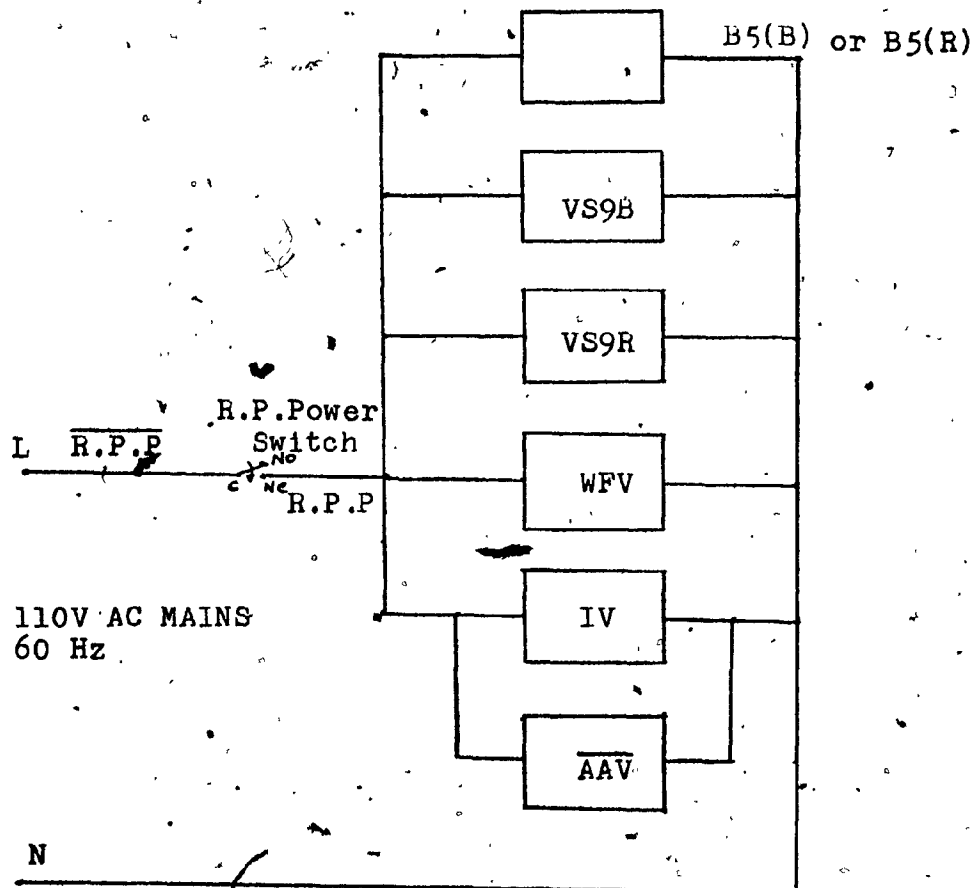

FIG. 3.5 CIRCUIT DIAGRAM TO SWITCH POWER ON TO THE PIRANI GAUGE, VACUUM SWITCHES, WATER FLOW, ISOLATION AND AIR ADMITTANCE VALVES.

TABLE 3.2

TRUTH TABLE TO SWITCH POWER ON TO THE PIRANI GAUGE, VACUUM SWITCHES, WATER FLOW, ISOLATION AND AIR ADMITTANCE VALVES)

R.P.	B5(B)	B5(R)	VS9(B)	VS9(R)	WFV	IV	A.A.V.
1	1	0	1	1	1	1	0
1	0	1	1	1	1	1	0
0	0	0	0	0	0	0	1

Desired condition

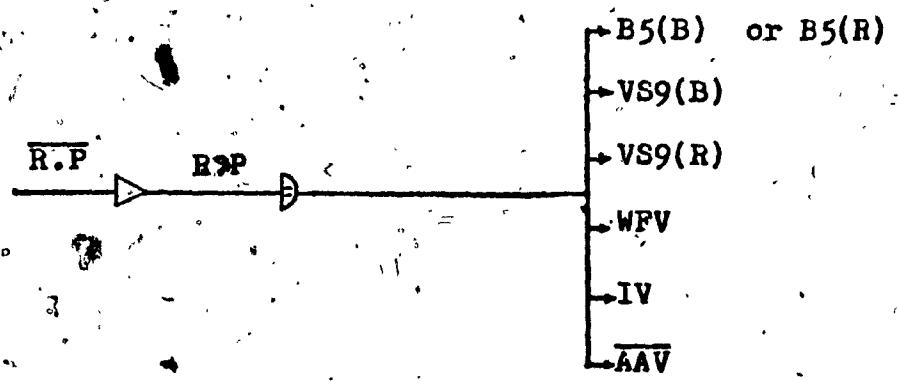

FIG. 3.6 LOGIC DIAGRAM TO SWITCH POWER ON TO THE PIRANI GAUGE, VACUUM SWITCHES, WATER FLOW, ISOLATION AND AIR ADMITTANCE VALVES.

### 3.5 TIMER:

When the rotary pump is switched on, the one revolution per half an hour timer starts. The detailed circuit diagram for the timer is shown in Fig. 3.7.

On the timer shaft, a cam, which operates a microswitch, MS1, at an interval of eight minutes and twenty two minutes, is fixed by means of a screw.

The microswitch, MS1, is in the relaxed position initially and the "Normally Closed" contact is closed. Therefore, the relay R1B energizes. R1B1, which is "Normally Open", closes as soon as the relay R1B energizes and starts the timer. The timer light comes ON.

At the end of the eight minute period, the cam presses the microswitch, MS1, and closes the "Normally Open" contact. The relay R1B de-energizes and opens the R1B1 contact. Thus, the timer is switched off at the end of the eight minute period.

When the spring loaded cool-down switch is pressed in order to shut down the system, the relay R1C energizes and is held energized by its contact R1C 1.

The "Normally Open" R1C2 contact closes. Thus the timer starts.

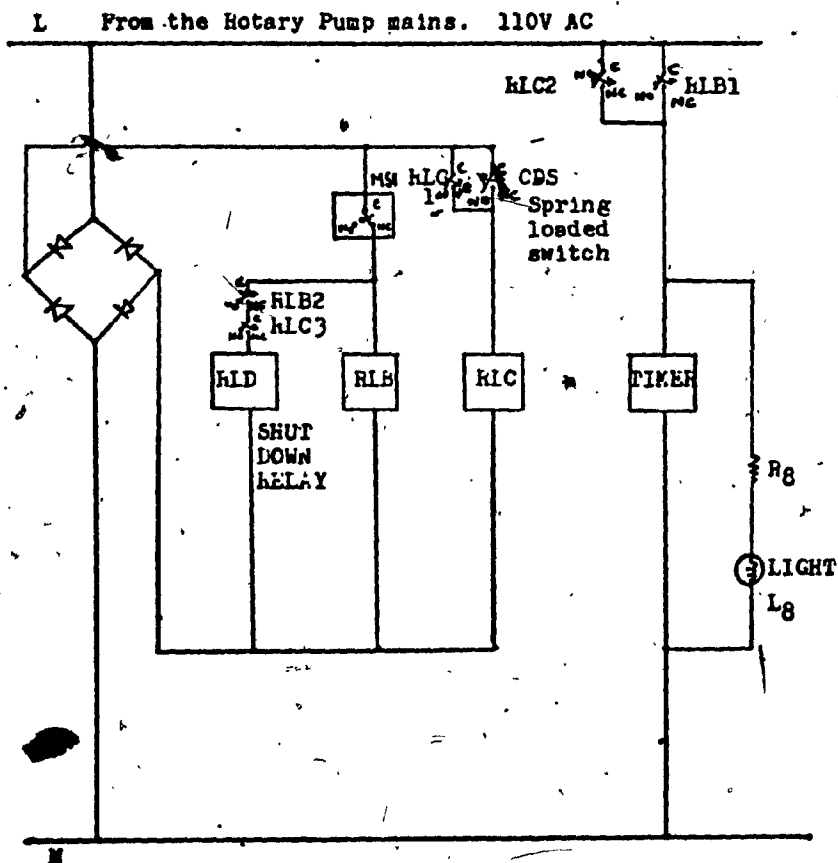

Fig. 3.7 DETAILED CIRCUIT DIAGRAM FOR THE TIMER

At the end of the twenty two minute cool-down period, the cam releases the microswitch MS1. The MS1 comes back to the relaxed position and the "Normally Closed" contact closes. The relay RLB energizes and the "Normally Open" RLB1 closes. Thus, both RLB1 and RLC1 contacts are closed. But, since both the relays RLB and RLC are energized, the "Normally Open" contacts RLB2 and RLC2 close and thus the shut-down relay RLD energizes. The "Normally Closed" RLD1 opens and the rotary power switches off. Thus the timer stops.

The basic circuit diagram to switch the timer power ON is shown in Fig. 3.8 and refers to section 3 of the complete circuit diagram, Fig. 3.1.

Table 3.3 shows the truth table for starting the timer. The unique logic equation for starting the timer is

$$\text{TIMER} = \text{RLB1} + \text{RLC2}$$

which leads to the logic diagram shown in Fig. 3.9.



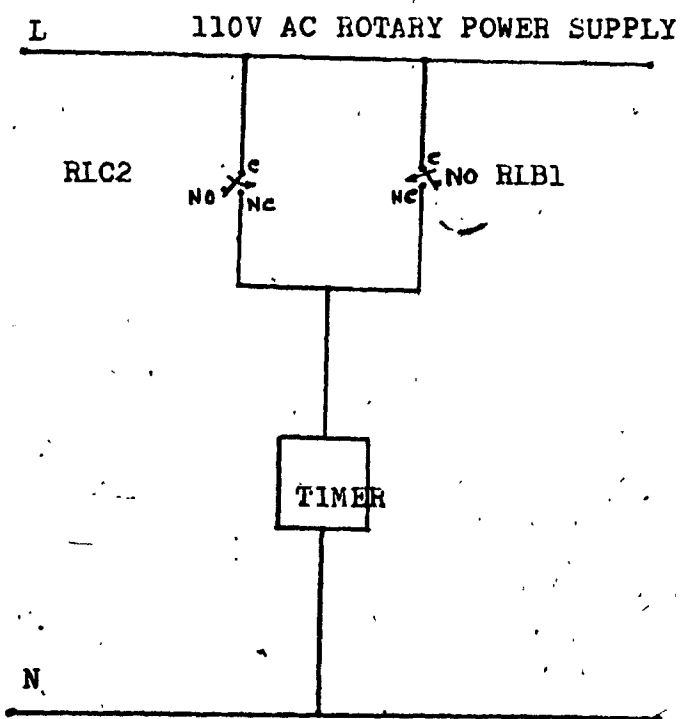

FIG. 3.8 BASIC CIRCUIT DIAGRAM TO START THE TIMER

TABLE 3.3

TRUTH TABLE TO SWITCH THE TIMER POWER ON:

HLB1 (MS1)	RLC2 (CDS)	TIMER
0	0	0
1	0	1
0	1	1
1	1	0

Desired condition

Rotary Power OFF

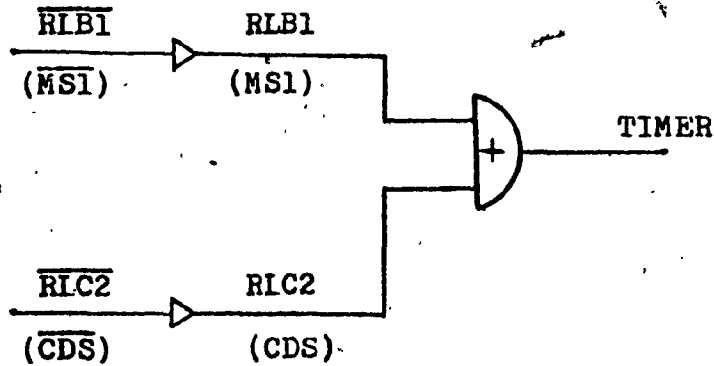

FIG. 3.9 LOGIC CIRCUIT FOR TIMER POWER ON

### 3.6 TO OPEN (ENERGIZE) THE BACKING VALVE:

A detailed circuit diagram to open (energize) the backing valve with a delay is shown in Fig. 3.10.

The reason for opening the backing valve with a delay is as follows:

In order to speed up the evacuation process, sometimes the diffusion pump side is left under vacuum overnight with the system switched off so that it will not be necessary to evacuate the diffusion pump side again next day.

If the backing valve opens as soon as the rotary pump is ON, the vacuum in the diffusion pump side will be destroyed because of the pressure in the rotary pump side. Thus, it is necessary for the rotary pump to evacuate that pressure first before the backing valve opens.

Thus, the backing valve must open with a delay compared to the rotary pump. The thermistors in the backing valve circuit provide this delay.

In order to fully appreciate the sequences of operation, the following explanation for the contacts is given:

- e) RLC4 : Normally Closed. This remains closed when the cool-down switch is not pressed.

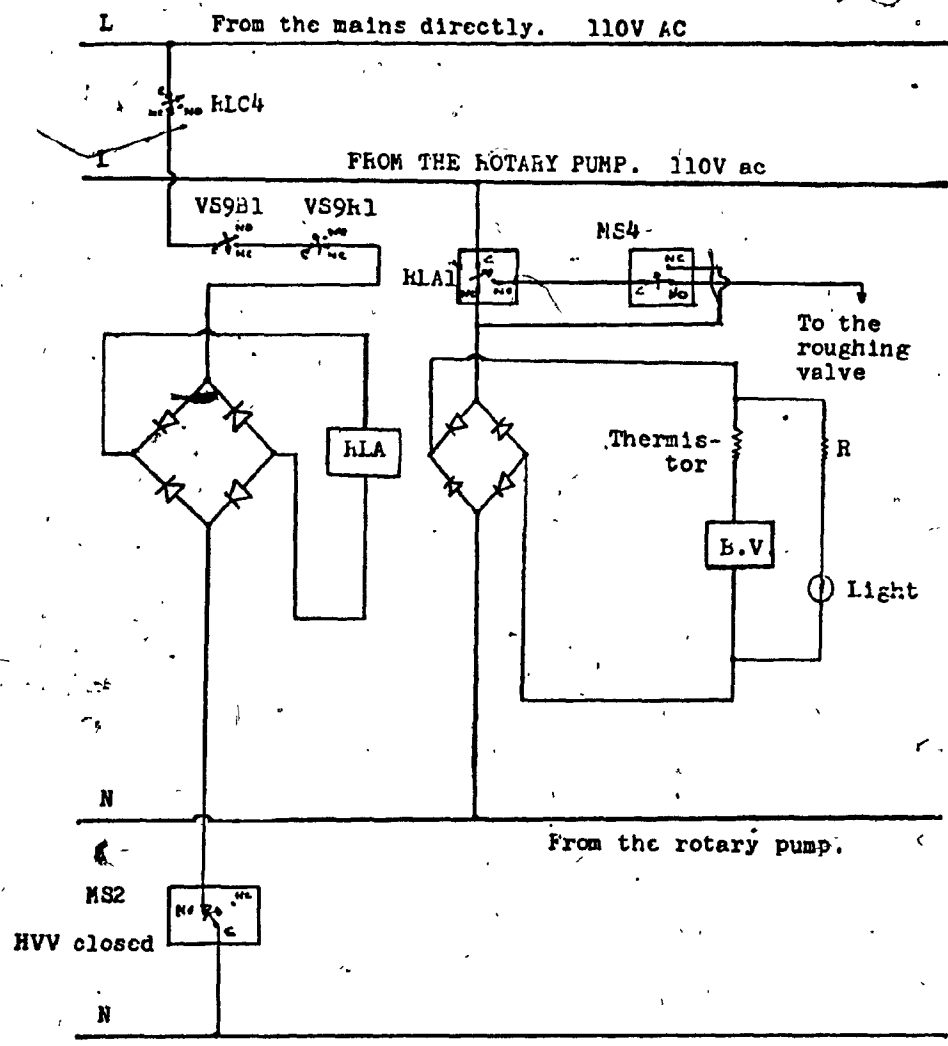

Fig. 3.10 DETAILED CIRCUIT DIAGRAM TO OPEN THE BACKING VALVE

- b) VS9B1 : Normally Open. When the vacuum in the backing line is better than 0.08 torr, it closes.
- c) VS9R1 : Normally Closed. When the vacuum in the roughing line is worse than 0.08 torr, the switch remains closed.
- d) MS2 : Normally Open. When the high vacuum valve is closed, the MS2 remains open. When the valve is opened, the MS2 contact moves over from 'Normally Open' to 'Normally Closed' position.
- e) RLA : Normally Closed. When the relay HLA is not energized, the RLA1 remains in the 'Normally Closed' position.
- f) MS4 : Normally Closed when the chamber air admittance valve is opened. When the valve is closed, the switch contact goes over to the 'Normally Open' position.

3.6.1 The backing valve opening: Starting and Intermediate conditions:

The backing valve will open during two conditions, namely at (1) Starting condition and (2) Intermediate condition.

3.6.1.1 Starting condition:

During the starting condition, the backing valve

opens to evacuate the diffusion pump side first and then to provide the necessary backing to the diffusion pump.

When the relay RLA is not energized, the RLA1 remains in the 'Normally Closed' position. The supply to the backing valve is connected and the valve energizes and opens.

The basic circuit diagram to open the valve is given in Fig. 3.11 and refers to section 4 of the complete circuit diagram, Fig. 3.1.

Table 3.4 is the truth table for the starting condition. The logic equation is

$$B V = RLA1$$

which leads to the logic diagram shown in Fig. 3.12.

A more detailed circuit diagram for the starting condition is shown in Fig. 3.13. A detailed truth table is given in table 3.5. The logic equation is given by

$$B V = RLC4 \cdot \overline{VS9B1} \cdot VS9R1 \cdot \overline{MS2}$$

$$1 = 1 \cdot 0 \cdot 1 \cdot 0$$

A more detailed logic diagram is shown in Fig. 3.14.

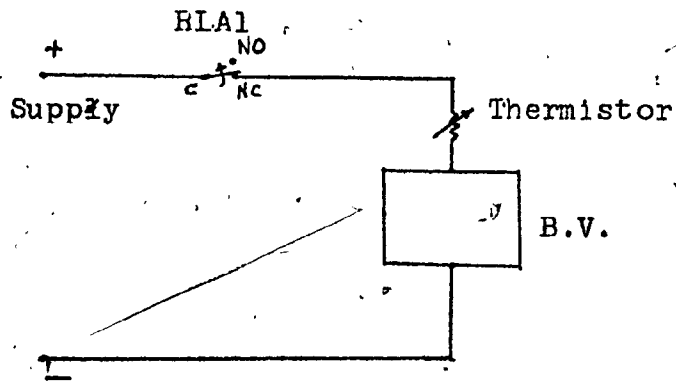

FIG. 3.11 BASIC CIRCUIT DIAGRAM TO OPEN THE BACKING VALVE: FOR THE STARTING CONDITION.

TABLE 3.4

TRUTH TABLE FOR THE STARTING CONDLITION:

RLA1	BV
1	1
0	0

← Valve is open  
(energized).

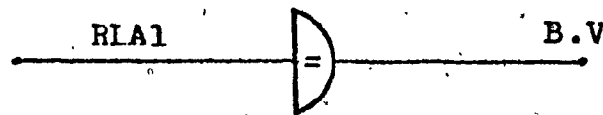

FIG. 3.12 LOGIC DIAGRAM TO OPEN THE BACKING VALVE;  
FOR THE STARTING CONDITION.



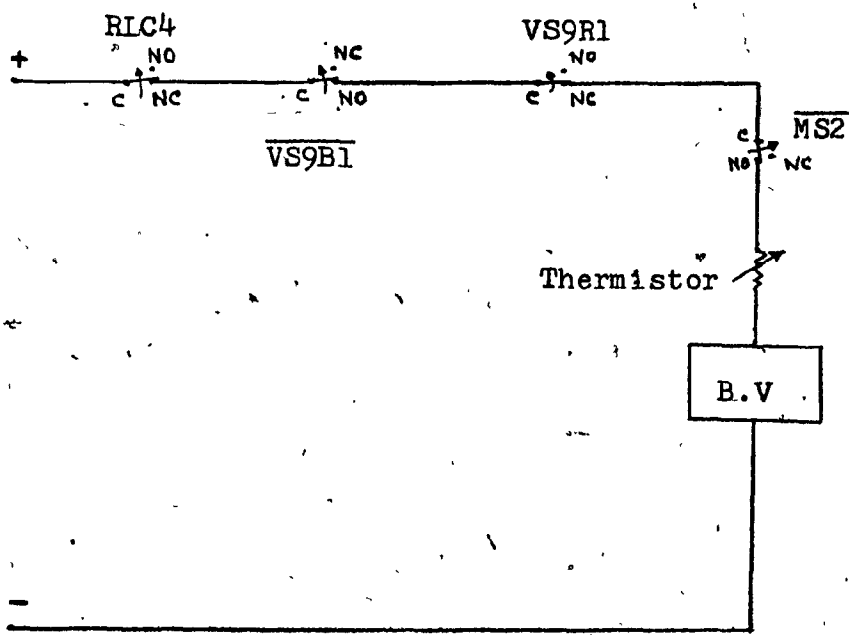

FIG. 3.13 DETAILED CIRCUIT TO OPEN THE BACKING VALVE: FOR THE STARTING-CONDITION.

TABLE 3.5

DETAILED TRUTH TABLE TO SHOW THE OPERATION OF THE BACKING VALVE: FOR THE STARTING CONDITION:

RLC4	VS9B1	VS9R1	MS2	BV
0	0	0	0	0
0	0	0	1	1
0	0	1	0	1
0	1	0	0	1
1	0	1	0	1
1	1	1	0	0
1	1	1	1	1

← Power OFF condition.  
 ← Backing valve energised (open).  
 Note: When MS2 is closed, i.e. HVV is open, the backing valve opens regardless of the positions of other contacts.  
 ← Backing valve opens. Starting condition.  
 ← Backing valve not energised - (closed)  
 FOR STARTING CONDITION.

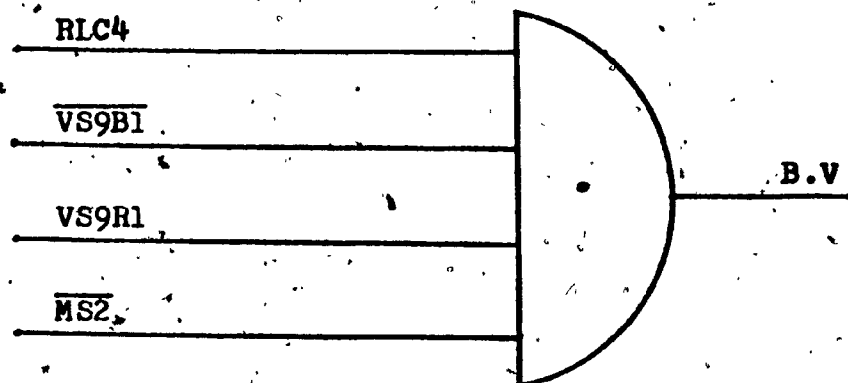

FIG. 3.14 DETAILED LOGIC DIAGRAM TO OPEN THE BACKING VALVE FOR THE STARTING CONDITION.

### 3.6.1.2 INTERMEDIATE CONDITION:

During the Intermediate condition, the chamber air admittance valve is opened to perform certain tasks, such as arranging or lining the work pieces etc., which may take some time to complete. During this time, the backing valve must open to back the diffusion pump. If the diffusion pump is left without backing for some time, the mercury or oil vapours will build-up in the diffusion pump side, which is inadvisable. Thus, during the intermediate condition, the backing valve opens to provide backing to the diffusion pump.

When the relay RLA energises, the RL1 contact moves from 'NC' to 'NO' position. When the chamber air admittance relay is opened, the MS4 moves from the 'NO' to 'NC' position. Thus, the supply to the backing valve is connected and the valve opens.

The simplified and detailed diagrams are shown in Figs. 3.15 and 3.16 respectively.

Table 3.6 shows the detailed truth table for the intermediate condition.

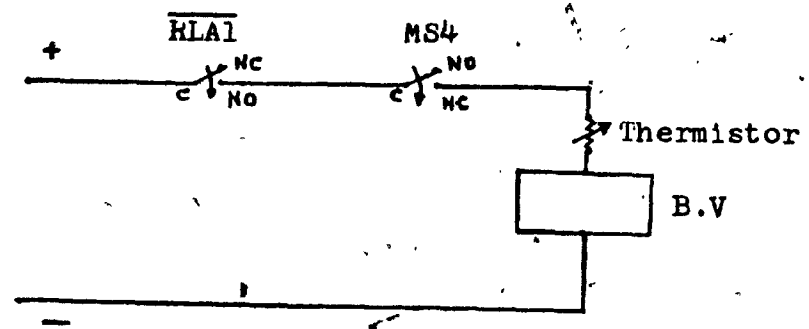

FIG. 3.15 SIMPLIFIED CIRCUIT DIAGRAM TO OPEN THE BACKING VALVE: THE INTERMEDIATE CONDITION.

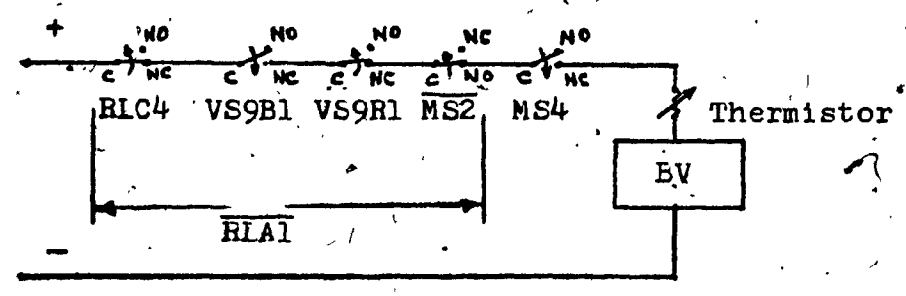

FIG. 3.16 DETAILED CIRCUIT DIAGRAM TO OPEN THE BACKING VALVE: THE INTERMEDIATE CONDITION.

TABLE 3.6

TRUTH TABLE TO SHOW THE OPERATION OF THE BACKING VALVE:  
FOR THE INTERMEDIATE CCNDITION:

RLC4	VS9B1	VS9R1	MS2	MS4	B.V
0	0	0	0	0	0
0	0	0	0	1	0
0	0	0	1	0	0
.	.	.	.	.	0
.	.	.	.	.	0
.	.	.	.	.	0
1	1	1	0	0	0
1	1	1	0	1	1
1	1	1	1	1	0

B.V. energises:  
 Intermediate  
 condition.

The detailed logic equation for the intermediate condition is

$$B V = R1C4 \cdot VS9B1 \cdot VS9R1 \cdot \overline{MS2} \cdot MS4$$

$$1 = 1 \cdot 1 \cdot 1 \cdot 0 \cdot 1$$

The logic diagram for the intermediate condition is shown in Fig. 3.17.

3.6.1.3 To open the backing valve: For starting and intermediate conditions combined:

The combined basic circuit diagram for opening the backing valve is shown in Fig. 3.18.

Table 3.7 is the basic truth table for opening the backing valve.

The logic equation is given by

$$B V = RL1A1 + \overline{HL1A1} \cdot MS4$$

which leads to the basic logic diagram shown in Fig. 3.19.

The combined detailed circuit diagram explaining each contact position for opening the backing valve is shown in Fig. 3.20.

The detailed truth table is shown in table 3.8.

The detailed logic equation is

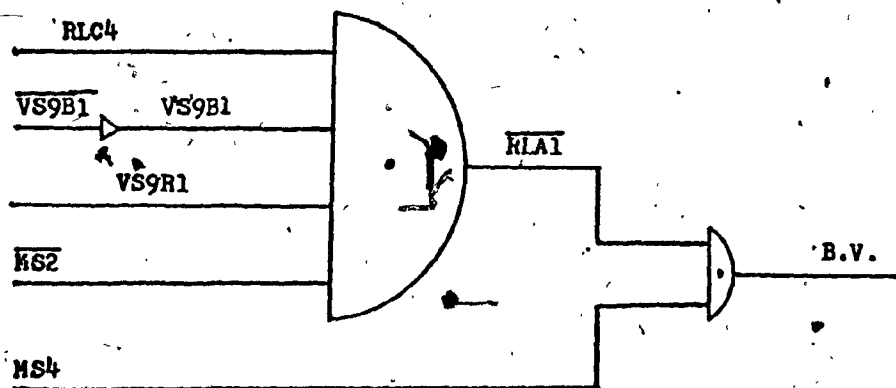

FIG. 3.17 DETAILED LOGIC DIAGRAM TO OPEN THE  
BACKING VALVE: THE INTERMEDIATE  
CONDITION.



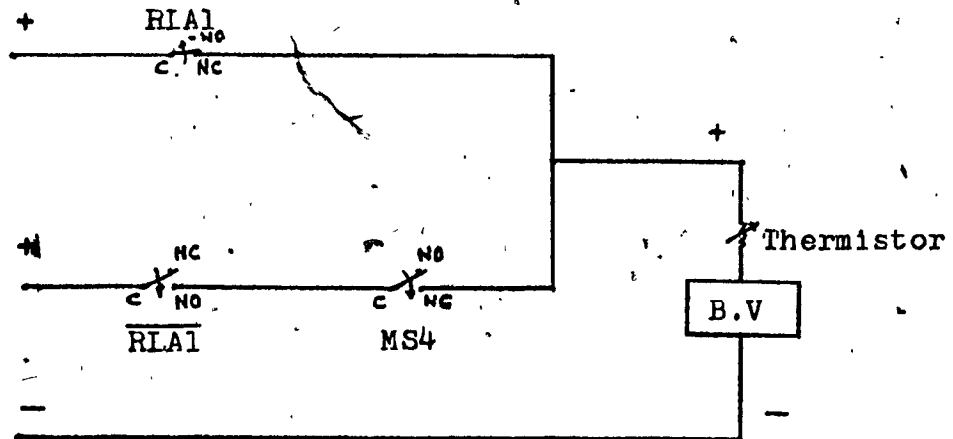

FIG. 3.18 BASIC CIRCUIT DIAGRAM TO OPEN THE BACKING VALVE: FOR THE STARTING AND THE INTERMEDIATE CONDITIONS COMBINED.

TABLE 3.7

BASIC TRUTH TABLE FOR THE STARTING AND THE INTERMEDIATE  
CONDITIONS COMBINED:

RLA1	MS4	B.V
1	-	1
0	1	1
1	1	1
0	0	0

← Backing valve energizes.

Note: When the RLA1 'Normally Closed' contact is closed, there is supply to the backing valve and hence the valve will energize. The position of the MS4 contact, whether open or close, does not influence the opening of the valve once the RLA1 NC contact is closed.

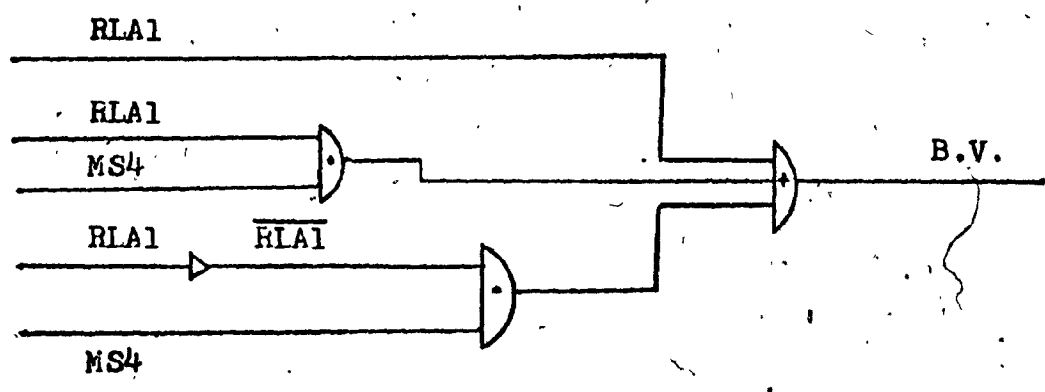

FIG. 3.19 BASIC LOGIC DIAGRAM TO OPEN THE BACKING VALVE FOR THE STARTING AND THE INTERMEDIATE CONDITIONS COMBINED.

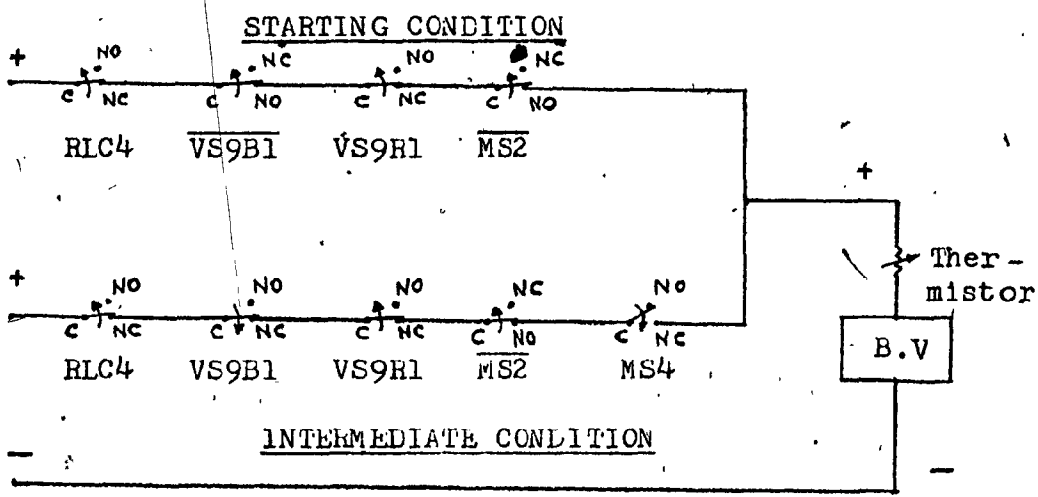

FIG. 3.20) DETAILED CIRCUIT DIAGRAM FOR OPENING THE BACKING VALVE: FOR THE STARTING AND THE INTERMEDIATE CONDITIONS COMBINED.

TABLE 3.8

TRUTH TABLE TO OPEN THE BACKING VALVE FOR STARTING  
AND INTERMEDIATE CONDITIONS COMBINED:

RLC4	VS9B1	VS9R1	MS2	MS4	EV	
0	0	0	0	0	0	← Power OFF condition
0	0	0	1	1	1	← Backing valve energizes (opens). (When MS2 is in "Normally Closed" position, the backing valve opens regardless of other contact positions.)
0	0	1	0	1	1	
0	1	0	0	1	1	
.	.	.	.	.	1	
.	.	.	.	.	1	
1	0	1	0	1	1	← Starting condition: Backing valve opens. In the starting condition, the position of the MS4 contact does not influence the opening of the backing valve.
1	0	1	0	0	1	
.	.	.	.	.	1	
1	1	1	0	0	0	
1	1	1	0	1	1	← Intermediate condition: backing valve opens.
1	1	1	1	1	1	

$$B.V = RLC4 \cdot \overline{VS9B1} \cdot VS9R1 \cdot \overline{MS2}$$

(Starting Condition)

$$+ RLC4 \cdot VS9B1 \cdot VS9R1 \cdot \overline{MS2} \cdot MS4$$

(Intermediate Condition)

$$1 = 1.0.1.0 + 1.1.1.0.1$$

Starting condition + Intermediate condition

which leads to the logic diagram shown in Fig. 3.21.

### 3.6.2 BUILT-IN PROTECTIONS:

The following protections are built-in the operation of the backing valve for safety reasons:

- a) When the high vacuum valve (HVV) is opened, MS2 contact closes and thus, the relay RLA cannot be energized even when RLC4, VS9B1 and VS9R1 are closed. i.e. The backing valve opens when the HVV is opened. This arrangement is necessary because the HVV is opened only when the chamber is to be evacuated by the diffusion pump and hence the backing valve must open so that the rotary pump backs the diffusion pump. Thus, the backing valve opens when the HVV is opened.

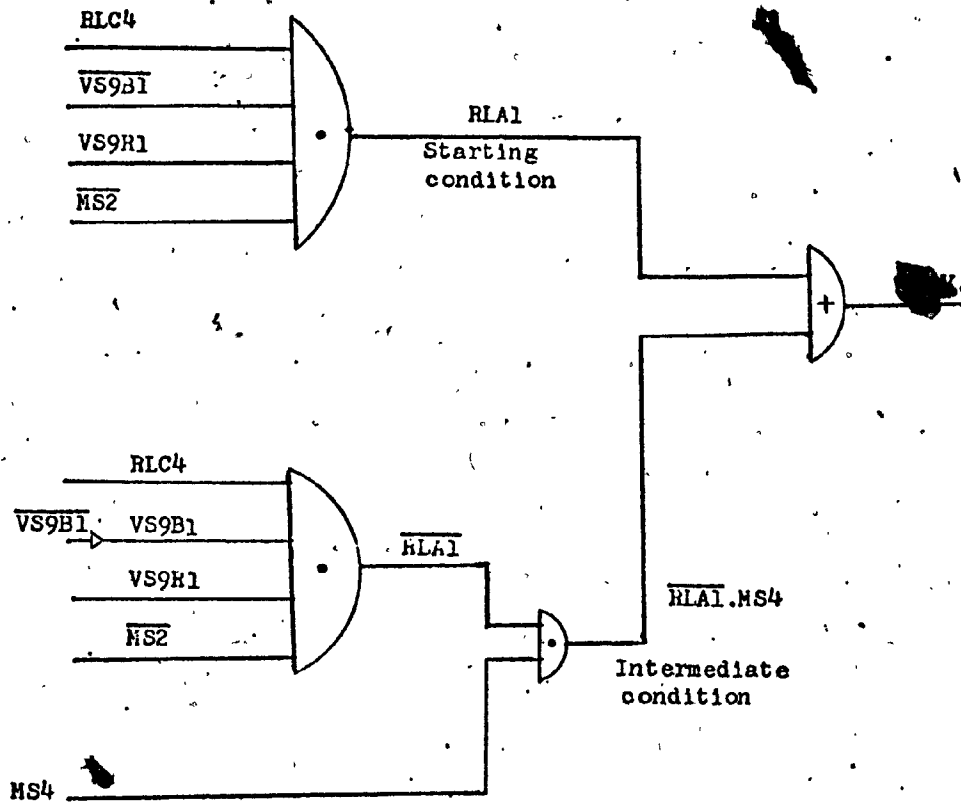

FIG. 3.21 DETAILED LOGIC DIAGRAM TO OPEN THE BACKING VALVE FOR THE STARTING AND THE INTERMEDIATE CONDITIONS COMBINED.

- b) When the cool-down switch, CDS, is pressed, RLC4 contact goes over to the NO position and thus the relay RLA cannot energize even when the roughing side vacuum is worse than 0.08 torr. This ensures that the backing valve opens and the roughing valve closes during the cool-down period. This arrangement is necessary so that the diffusion pump is backed by the rotary pump during the cool-down period. Thus, the backing valve opens during the cool-down period.

### 3.7 DIFFUSION PUMP:

The diffusion pump heater switches on when .

- a) RLC4 remains closed ie. when the cool-down switch is not pressed;
- b) VS9B1 closes ie. the backing vacuum is better than 0.08 torr, and
- c) ThS remains closed ie. the thermal (bi-metallic) switch remains closed when the diffusion pump outer case is within the preset temperature. ie. adequate supply of cold water is circulated around the diffusion pump outer case to cool the pump in order to condense the mercury or oil vapour for re-use.



The circuit diagram to switch on the diffusion pump heater is shown in Fig. 3.22 and refers to section 5 of the complete circuit diagram Fig. 3.1.

Truth table for the power on condition of the diffusion pump is given in Table 3.9.

The logic equation for the diffusion pump heater on condition is

$$DPH = RLC4 \cdot VS9B1 \cdot ThS$$

$$1 = 1 \cdot 1 \cdot 1$$

which leads to the logic diagram shown in Fig. 3.23.

### 3.8 TO OPEN (ENERGIZE) THE ROUGHING VALVE:

When the diffusion pump side has been evacuated to approximately 0.08 torr, the backing valve closes and then the roughing valve opens with a delay to enable the rotary pump to evacuate the chamber.

The reasons to open the roughing valve with a delay are given below:

Since the diffusion pump side has been evacuated first by the rotary pump, it is under vacuum; but the roughing side has not yet been evacuated and hence it is at atmospheric pressure. If the roughing valve opens before

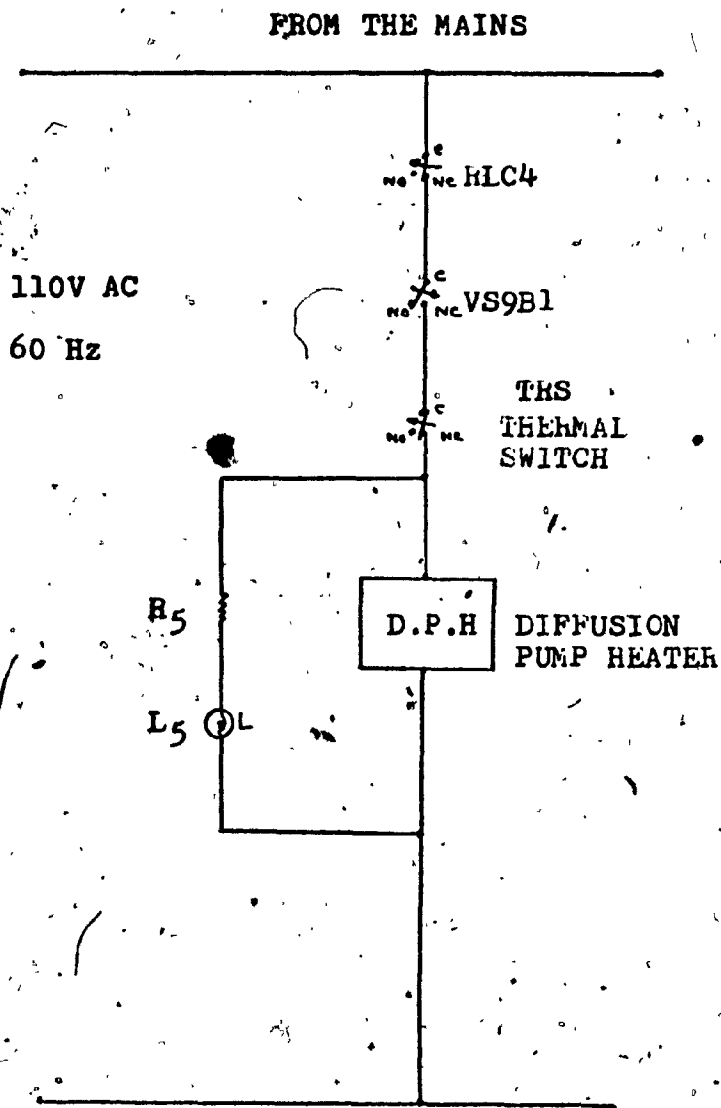
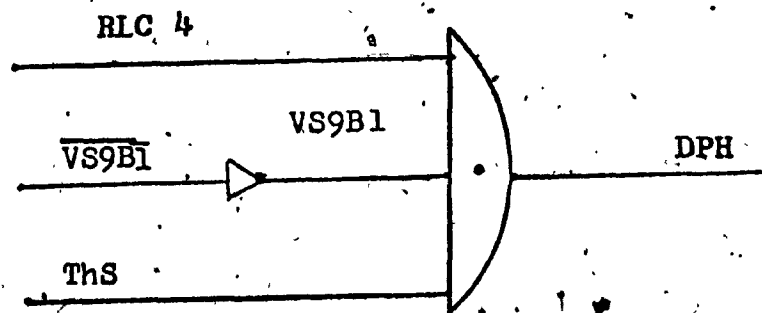

FIG. 3.22 CIRCUIT DIAGRAM TO SWITCH ON  
THE DIFFUSION PUMP HEATER.

TABLE 3.9

TRUTH TABLE TO SWITCH THE DIFFUSION PUMP HEATER ON:

HLC4	VS9B1	Ths	DPH
0	0	0	0
0	0	1	0
0	1	0	0
1	0	0	0
1	0	1	0
0	1	1	0
1	1	0	0
1	1	1	1

DPH  
ONFIG. 3.23 LOGIC DIAGRAM TO SWITCH THE  
DIFFUSION PUMP HEATER ON.

the backing valve closes, there will be a pressure link between the atmospheric pressure in the chamber and the vacuum in the diffusion pump. The diffusion pump side pressure will increase, thus destroying the vacuum and causing the mercury or oil vapour from the diffusion pump to foul up the system. Thus, in order to protect the system and to preserve the vacuum in the diffusion pump side, the roughing valve must open only after the backing valve has closed.

The detailed circuit diagram to operate the roughing valve is shown in Fig. 3.24.

#### 3.8.1 SEQUENCE OF OPERATION OF THE ROUGHING VALVE:

Explanations for RLC4, VS9B1, VS9R1, MS2, HLA1 and MS4 contacts are given in section 3.6.

The roughing valve opening is carried out as follows:

- a) When RLC4, VS9B1, VS9R1 and MS2 contacts are made, the relay RLA energizes and the HLA1 "NC" contact goes over to "NO" position. Thus, the supply to the backing valve is removed and the backing valve closes.
- b) As soon as the backing valve piston leaves the fully open position, the microswitch, MS3,

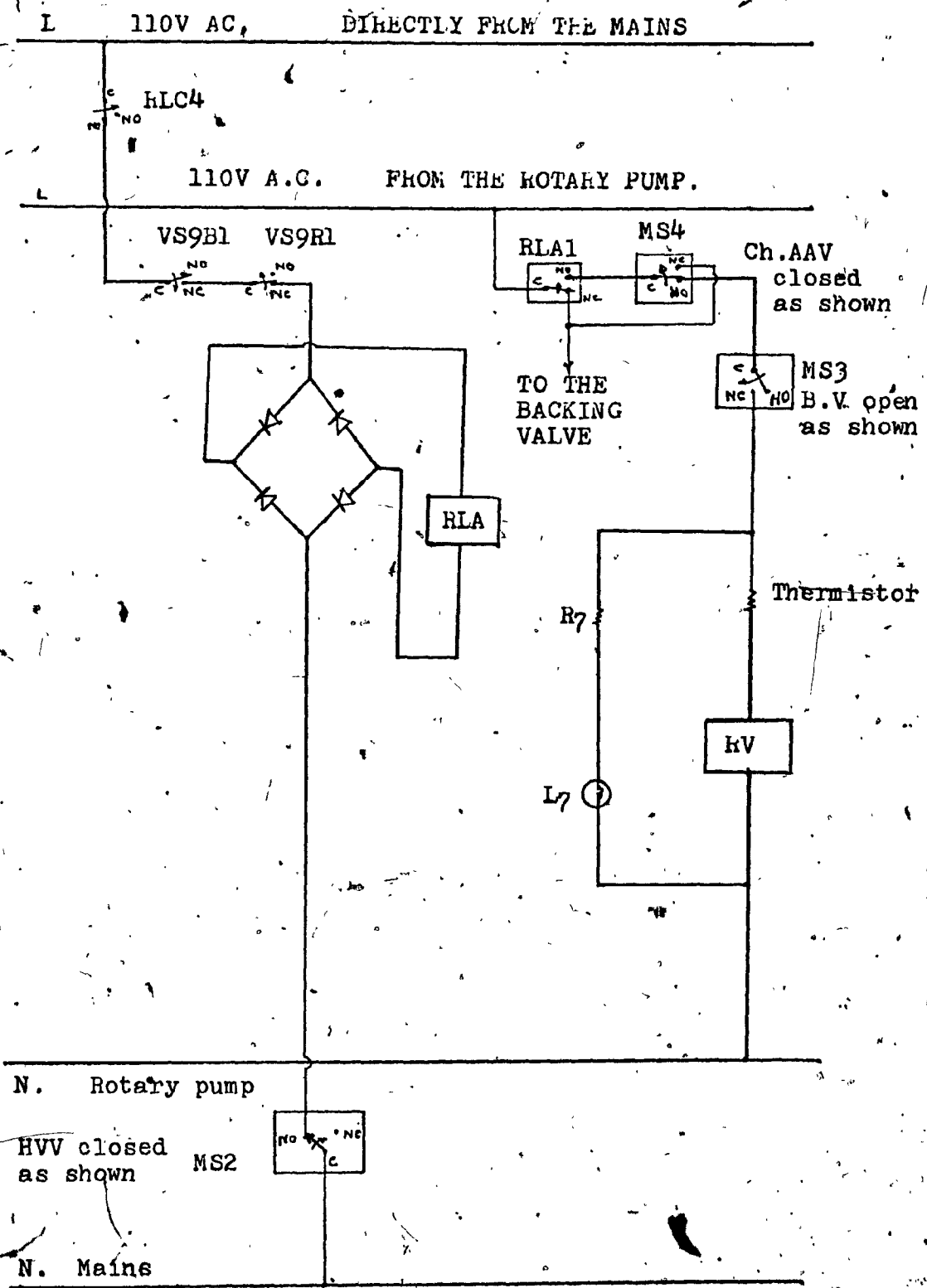

FIG. 3.24 DETAILED CIRCUIT DIAGRAM TO OPERATE THE ROUGHING VALVE.

built-in to the backing valve, is released and the MS3 "NO" contact moves to "NC" position.

- c) If the chamber air admittance valve is closed, the MS4 "NO" contact is connected.

Thus, RL1, MS4 and MS3 contacts are all made and the supply to the roughing valve is connected. But, because of the thermistor in the roughing valve circuit, the roughing valve opens with a delay to enable the backing valve to close fully.

The roughing valve closing is carried out as follows:

When the chamber has been evacuated to approximately 0.08 torr by the rotary pump or when the chamber air admittance valve is opened, in order to avoid a pressure link, the roughing valve closes before the backing valve opens as explained below:

- a) If either RL1 or MS4 contact changes over, then the continuity to the roughing valve is broken and the valve closes almost immediately.
- b) The supply to the backing valve is reconnected. The backing valve thermistors have cooled down slightly since the valve was not energized (closed) when the chamber was evacuated by the rotary pump. Because of the initial

high resistance of the cooled thermistors, the backing valve opens with a delay. Thus, the roughing valve closes first and then only the backing valve opens.

The basic switching circuit to open the roughing valve is shown in Fig. 3.25. and refers to section 6 of the complete circuit diagram, Fig. 3.1. The detailed switching circuit is shown in Fig. 3.26.

The logic equations for the roughing valve opening are given below:

$$\begin{aligned}
 RV &= \overline{HLA1} \cdot \overline{MS4} \cdot MS3 \quad \text{or} \\
 RV &= RLC4 \cdot VS9B1 \cdot VS9R1 \cdot \overline{MS2} \cdot \overline{MS4} \cdot MS3 \\
 1 &= 1 \cdot 1 \cdot 1 \cdot 0 \cdot 0 \cdot 1 \\
 RV &= \overline{CDS} \cdot \begin{matrix} 0.08 \text{ mmHg} \\ \text{backing} \end{matrix} \cdot \begin{matrix} 0.08 \text{ mmHg} \\ \text{roughing} \end{matrix} \cdot (HVV) \\
 &\quad \cdot (CAAV) \cdot (\overline{BV})
 \end{aligned}$$

Table 3.10. shows the truth table for the operation of the roughing valve.

The logic circuit diagram obtained from the logic equation is shown in Fig. 3.27.

### 3.8.2 BUILT-IN SAFETY PROTECTIONS:

The following safety protections are built-into the operation of the roughing valve:

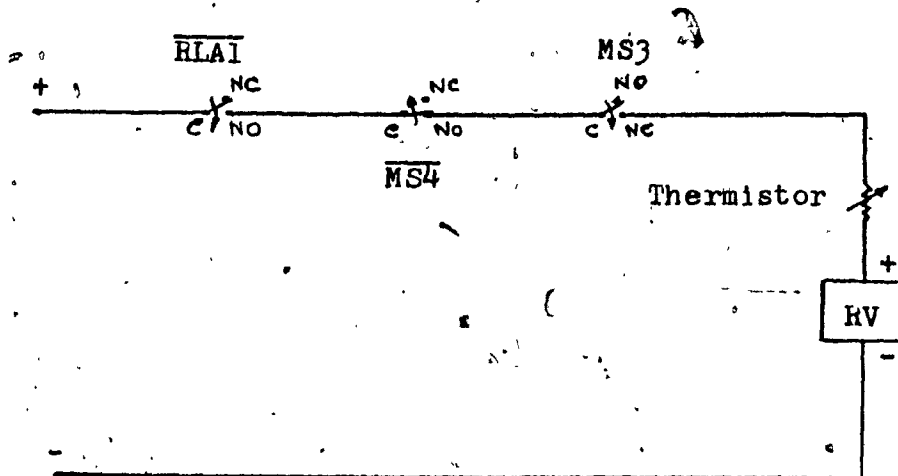

Fig. 3.25 BASIC SWITCHING CIRCUIT FOR THE OPERATION OF THE ROUGHING VALVE

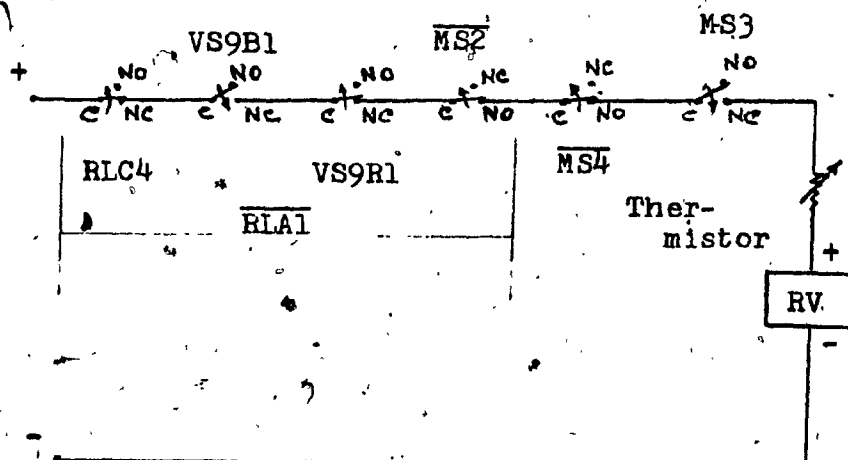

Fig. 3.26 DETAILED SWITCHING CIRCUIT FOR THE OPERATION OF THE ROUGHING VALVE



TABLE 3.10

TRUTH TABLE FOR THE OPERATION OF THE ROUGHING VALVE:

RIC4	VS9B1	VS9R1	MS2	MS4	MS3	R.V
0	0	0	0	0	0	0
0	0	0	0	1	0	0
0	0	0	1	0	0	0
.	.	.	.	.	.	0
.	.	.	.	.	.	0
.	.	.	.	.	.	0
.	.	.	.	.	.	0
.	.	.	.	.	.	0
1	1	1	0	0	1	1
.	.	.	.	.	.	0
.	.	.	.	.	.	0
.	.	.	.	.	.	0
1	1	1	1	1	1	0

← Roughing  
valve  
opens.

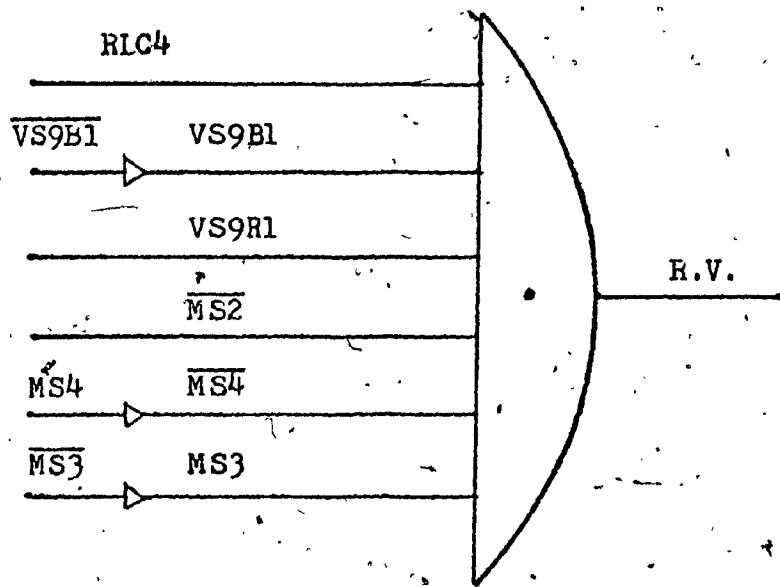

FIG. 3.27 LOGIC DIAGRAM SHOWING THE OPERATION OF THE ROUGHING VALVE.

- a) Both the roughing and the backing valves cannot either close or open at the same time when the system is switched on.
- b) The roughing valve closes and then the backing valve opens when the chamber air admittance valve is opened. The reason for this operation is explained in section 3.6.1.2.
- c) The roughing valve cannot open when the high vacuum valve is opened to enable the backing valve to back the diffusion pump.
- d) The roughing valve cannot open during the cool-down period since the backing valve must open to provide backing to the diffusion pump.

### 3.9 ALARM BELL:

The desired condition is that the alarm bell does not ring (ie. OFF) when the high vacuum valve is opened.

The circuit diagram is shown in Fig. 3.28. and refers to section 7 of the main circuit diagram, Fig. 3.1.

The following explanation of the relay contacts is given to appreciate the operation of the alarm bell:

- a) RLB5 remains closed when the timer is on for

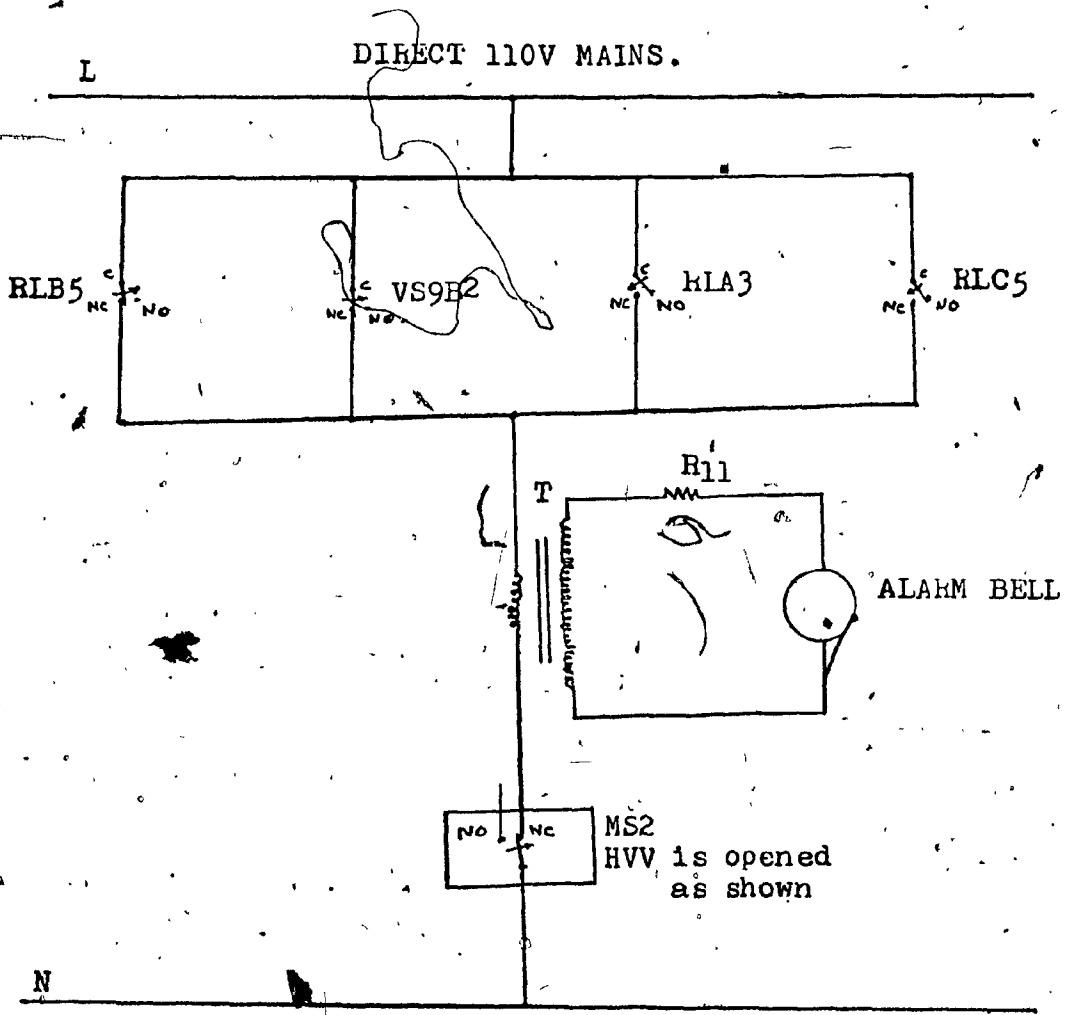

FIG. 3.28 CIRCUIT DIAGRAM TO OPERATE THE ALARM BELL

the first eight minute period during which time the diffusion pump heater is warming up and the roughing chamber is evacuated. When the eight minute period has elapsed, RLB5 will open.

- b) VS9B2 remains closed when the vacuum in the backing line is worse than 0.08 torr. When the vacuum is better than 0.08 torr, VS9B2 opens.
- c) RLA3 remains open when the roughing valve closes, (ie. not energized).
- d) RLC5 remains open when the cool-down switch is not pressed.
- e) MS2 "NO" contact goes over to "NC" when the high vacuum valve is opened.

#### 3.9.1 ALARM BELL OPERATION:

If an attempt is made to open the high vacuum valve when any one of the following relay contacts is closed, the alarm bell will ring to warn the operator not to open the valve. When all the relay contacts are open, the high vacuum valve can be opened safely by the operator.

Table 3.11 gives the truth table for the alarm

TABLE 3.11

TRUTH TABLE FOR THE ALARM BELL OPERATION: WHEN THE HVV  
IS OPENED.

RIB5	VS9B2	RIA3	RIC5	ALARM BELL
0	0	0	0	0
0	0	0	1	1
0	0	1	0	1
0	1	0	0	1
1	0	0	0	1
.	.	.	.	1
.	.	.	.	1
.	.	.	.	1
.	.	.	.	1
.	.	.	.	1
.	.	.	.	1
.	.	.	.	1
.	.	.	.	1
1	1	1	1	1

← Desired condition

bell "ON or OFF" operation, when the high vacuum valve is opened.

The logic equation for the desired alarm bell "OFF" condition, when the high vacuum valve (HVV) is opened, is

$$\overline{A.B.} = (\overline{RLB5} + \overline{VS9B2} + \overline{RLA3} + \overline{RLC5}).MS2$$

ie. 0 = 0 + 0 + 0 + 0 . 1

The logic diagram for the alarm bell "OFF" condition, when the high vacuum valve is opened, is given in Fig. 3.29.

### 3.10 READY LIGHT:

The "Ready" light comes "ON" when the following contacts are made, indicating that the high vacuum valve can be opened safely:

- a) VS9R2 closes when the roughing side vacuum is 0.08 torr.
- b) RLA2 remains closed when the backing valve is open.
- c) RLB3 closes eight minutes after start-up. The relay HLB de-energizes and the timer stops, and
- d) RLC6 remains closed when the cool-down switch

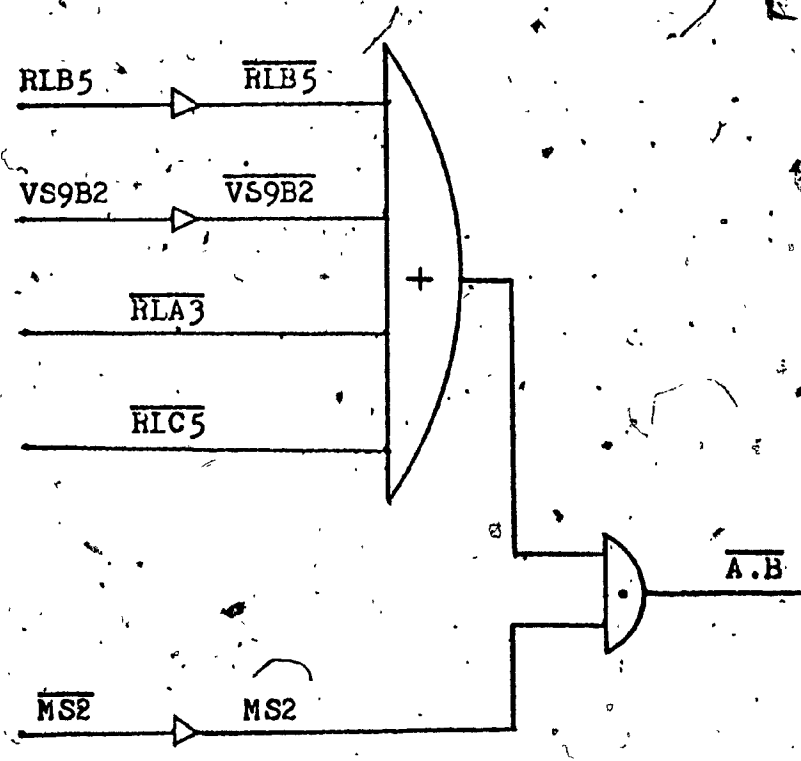

FIG. 3.29 LOGIC CIRCUIT DIAGRAM FOR THE ALARM BELL "OFF" CONDITION WHEN THE HIGH VACUUM VALVE IS OPENED.



is not pressed.

The circuit diagram for the "Ready" light power "ON" is shown in Fig. 3.30 and refers to section 8 of the complete circuit diagram, Fig. 3.1.

Table 3.12 refers to the truth table for the "Ready" light "ON" condition.

The logic equation for the "Ready" light ON condition is

$$R.L = VS9R2 \cdot RLA2 \cdot RLB3 \cdot RLC6$$

$$1 = 1 \cdot 1 \cdot 1 \cdot 1$$

which leads to the logic diagram shown in Fig. 3.31.

### 3.11 COOL-DOWN:

When the spring-loaded cool down switch (CDS) is pressed, usually at the end of the day or at the completion of the operation, to shut down the system, the following sequences take place

- a) The relay RLC energizes and is held energized by its own RLC1 contact. Thus, the timer starts.
- b) The "Normally Closed" RLC4 opens and the diffusion pump heater switches OFF.

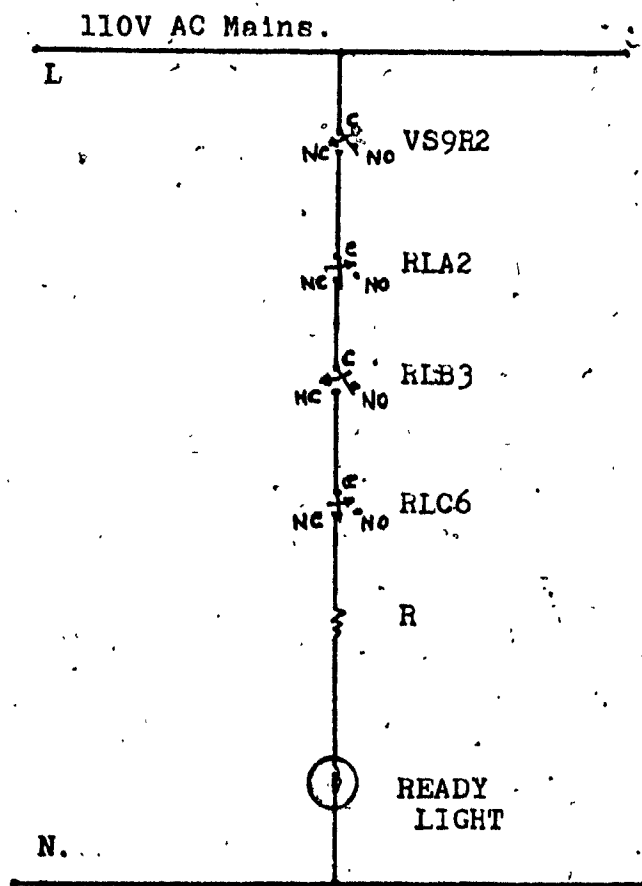

FIG. 3.30 CIRCUIT DIAGRAM FOR THE  
"READY" LIGHT POWER "ON"

TABLE 3.12TRUTH TABLE FOR THE "READY" LIGHT POWER "ON"

VS9K2	H1A2	H1B3	H1C6	h.I
0	0	0	0	0
0	0	0	1	0
0	0	1	0	0
.	.	.	.	0
.	.	.	.	0
.	.	.	.	0
.	.	.	.	0
.	.	.	.	0
1	1	1	0	0
1	1	1	1	1

← READY  
LIGHT ON.

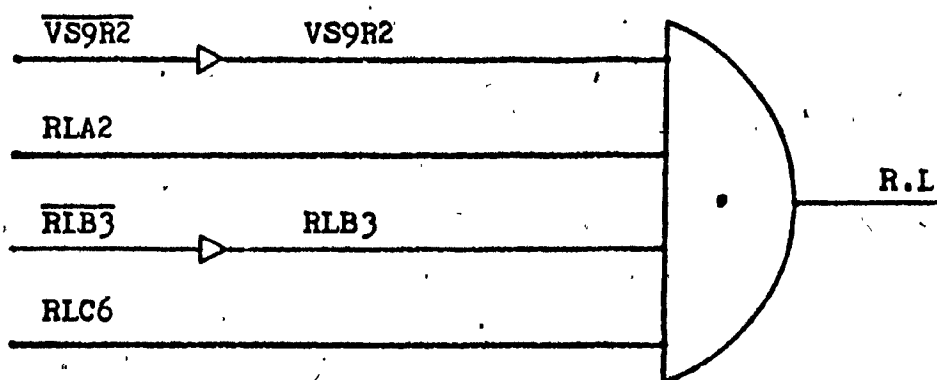

FIG. 3.31 LOGIC DIAGRAM SHOWING THE "READY" LIGHT  
POWER "ON" CONDITION.

- c) The relay R1A cannot energize since RLC4 is open, and thus, the roughing valve cannot open during the cool-down period.
- d) The RLC6 contact opens and the "Ready" light switches "OFF".
- e) The RLC7 contact closes and the warning light comes ON.

The circuit diagram for the cool-down switch operation is shown in Fig. 3.32.

Table 3.13 gives the truth table for the cool-down switch operation:

The logic equation is given by

$$CDS = \overline{TIMER} \cdot \overline{DIFF PUMP HEATER} \cdot \overline{RV} \cdot \overline{RL} \cdot WL$$

$$1 = 1 \cdot 0 \cdot 0 \cdot 0 \cdot 1$$

which leads to the logic diagram shown in Fig. 3.33.

### 3.12 WARNING LIGHT:

When the cool-down switch is pressed, the relay R1C energizes and closes the "Normally Open" RLC7 contact. The warning light comes on, indicating that the cool-down switch is pressed and the high vacuum valve must not be opened.

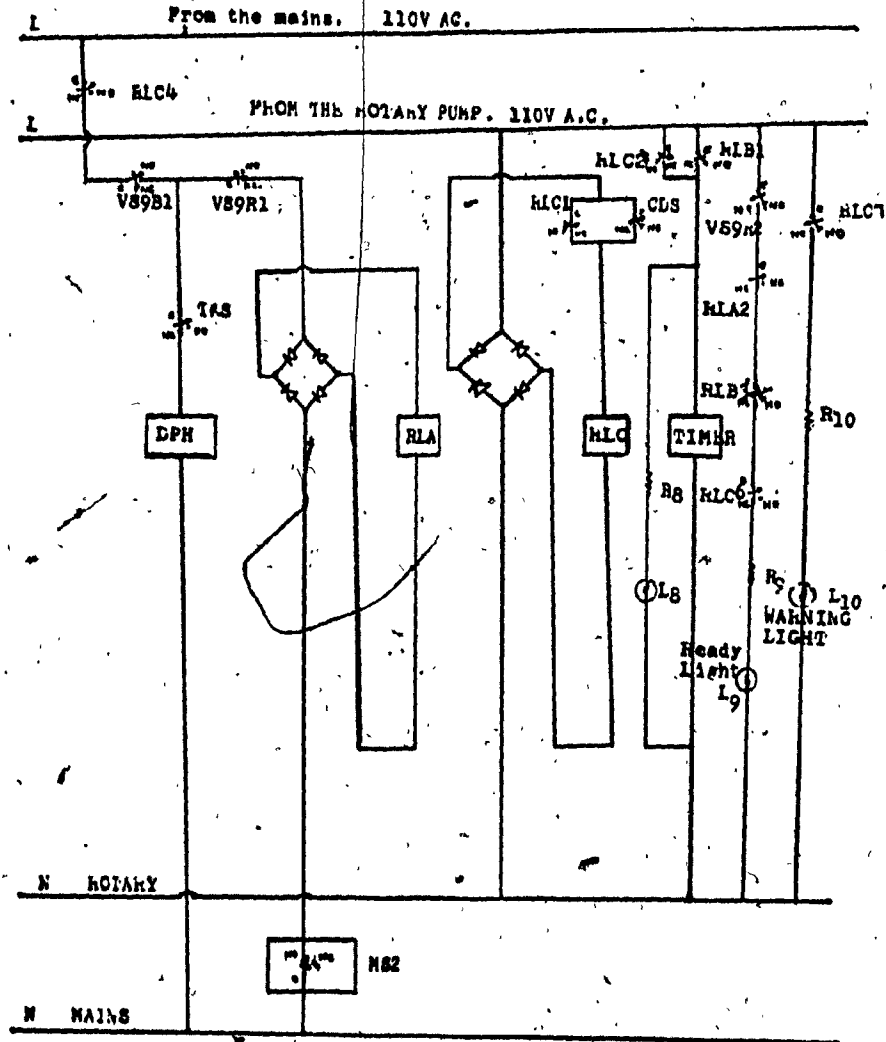

FIG. 3.32 CIRCUIT DIAGRAM FOR THE COOL-DOWN SWITCH OPERATION.

TABLE 3.13

TRUTH TABLE SHOWING THE COOL DOWN SWITCH OPERATION:

TIMER	DIFF.PUMP	H.V.	H.L	WL	CDS
0	0	0	0	0	0
0	0	0	0	1	0
0	0	0	1	0	0
.	.	.	.	.	0
.	.	.	.	.	0
.	.	.	.	.	0
1	0	0	0	1	1
.	.	.	.	.	0
.	.	.	.	.	0
.	.	.	.	.	0
.	.	.	.	.	0
1	1	1	1	1	0

CDS  
pressed.

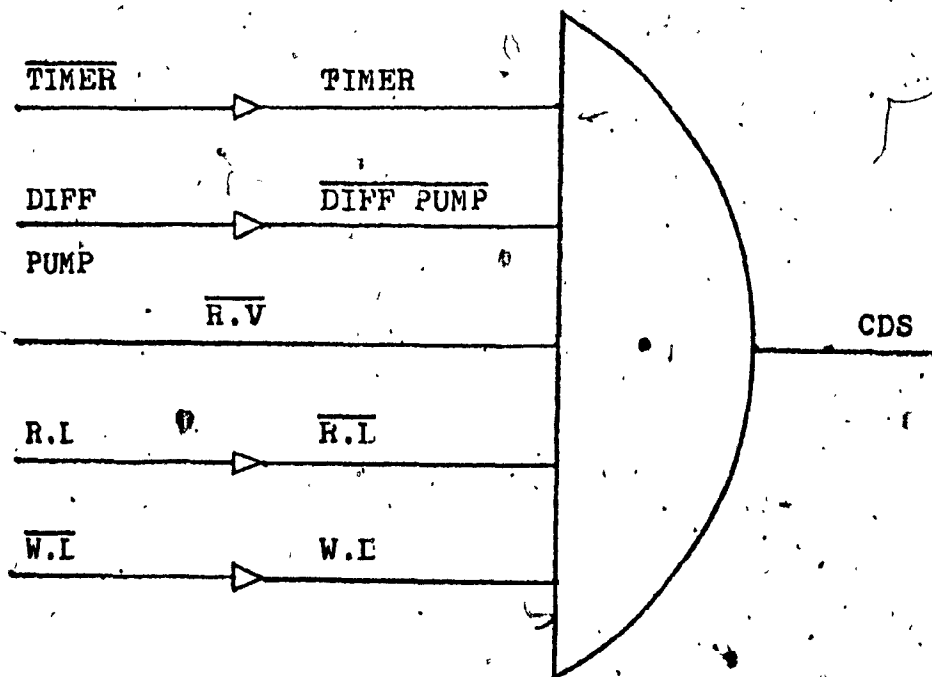

FIG. 3.33 LOGIC DIAGRAM SHOWING THE COOL DOWN SWITCH OPERATION.



The circuit diagram is shown in Fig. 3.34 and refers to section 9 of the complete circuit diagram, Fig. 3.1.

Table 3.14 gives the truth table for the warning light operation. The logic equation is

$$W.I = HLC?$$

which leads to the logic diagram shown in Fig. 3.35.

### 3.13 SHUT DOWN:

As explained previously, when the cool-down switch is pressed, the timer starts. When the diffusion pump has cooled down for about twenty two minutes, the timer-cam arrangement returns the microswitch, MS1, to the relaxed position and the MS1 contact moves from the "NO" to "NC" contact. The relay RLB thus energizes and the RLB2 contact closes.

Since the cool-down switch is already pressed, the relay HLC is energized and the HLC3 contact is closed.

Since both the contacts RLB2 and HLC3 are closed, the relay RID energizes and opens the RID1 contact to disconnect the supply to the rotary pump.

Thus, the rotary pump and, hence, the B5 Pirani gauge, VS9 vacuum switches, the backing, isolation and water

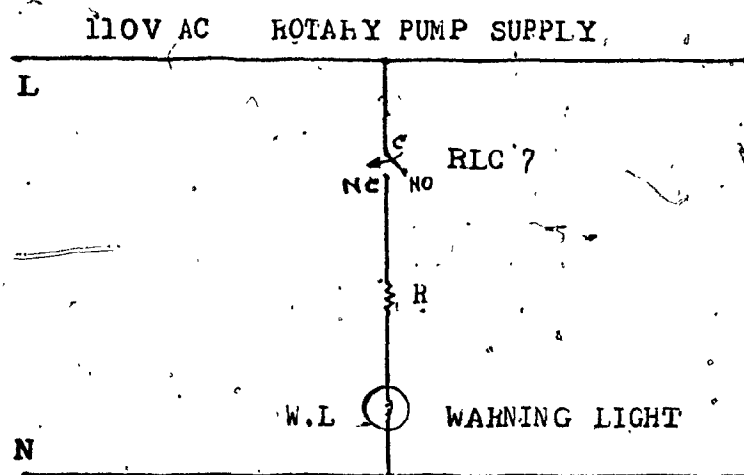

FIG. 3.34 CIRCUIT DIAGRAM FOR THE WARNING  
LIGHT OPERATION

TABLE 3.14

TRUTH TABLE FOR THE WARNING LIGHT OPERATION:

RLC 7 (CDS)	WL
0	0
1	1

WL ON

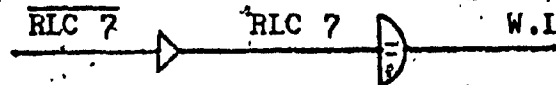

FIG. 3.35 LOGIC DIAGRAM FOR THE WARNING LIGHT OPERATION

flow valves are off. The air admittance valve built-in the isolation valve opens and admits air into the rotary pump line.

Thus, the complete system is shut down.

The circuit diagram explaining the shut down operation is shown in Fig. 3.36.

The basic circuit diagram to shut down the rotary pump is shown in Fig. 3.37.

Tables 3.15 and 3.16 show the basic and the detailed truth tables respectively to shut down the rotary pump and hence the system.

The basic logic equation to shut-down the rotary pump is

$$\overline{R.P.} = \overline{RTD1}$$

which leads to the logic diagram shown in Fig. 3.38.

The detailed logic equation to shut-down the rotary pump is

$$\begin{aligned} \overline{R.P.} &= \overline{R1B2 \cdot R1C3} \\ &= \overline{MS1 \cdot CDS} \end{aligned}$$

which leads to the detailed logic diagram shown in Fig. 3.39.

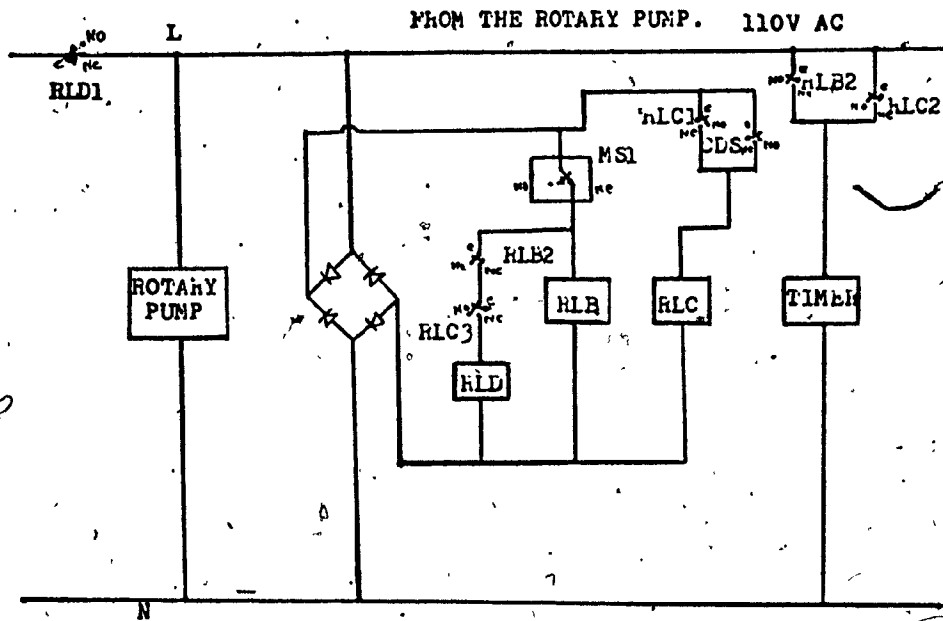

FIG. 3.36 CIRCUIT DIAGRAM FOR THE SHUT-DOWN OPERATION.

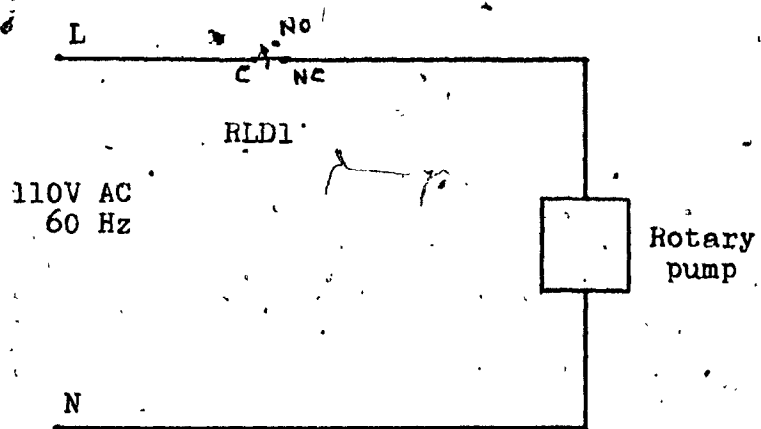

FIG. 3.37 BASIC CIRCUIT DIAGRAM TO SHUT-DOWN THE ROTARY PUMP AND HENCE THE SYSTEM.

TABLE 3.15

BASIC TRUTH TABLE TO SHUT-DOWN THE ROTARY PUMP:

RLD1	R.P
1	1
0	0

← Required condition

TABLE 3.16

DETAILED TRUTH TABLE TO SHUT-DOWN THE ROTARY PUMP:

RLB2 (MS1)	RLC3 (CDS)	R.P
0	0	1
0	1	1
1	0	1
1	1	0

← Required condition

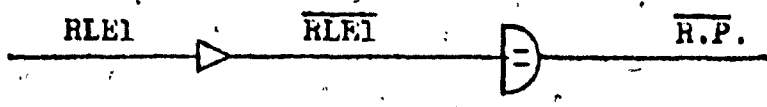

FIG. 3.38 BASIC LOGIC DIAGRAM TO SHUT-DOWN THE ROTARY PUMP AND HENCE THE SYSTEM.

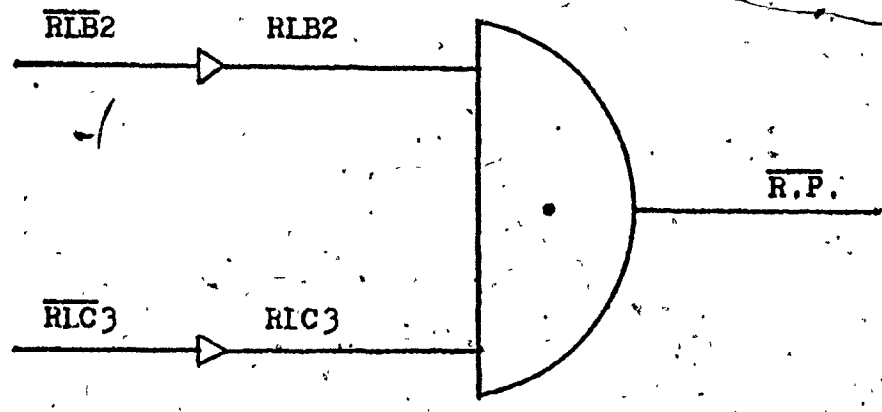

FIG. 3.39 DETAILED LOGIC DIAGRAM TO SHUT-DOWN THE ROTARY PUMP



### 3.14 TO OPERATE THE ISOLATION/AIR ADMITTANCE VALVE:

The isolation and the air admittance valves are built-into one unit and are powered from the same supply and hence they are considered together in this section.

When energized, the isolation valve opens and simultaneously the air admittance valve closes to prevent air entering into the rotary pump side. When not energized, the isolation valve closes and opens the air admittance valve at the same time to admit air into the rotary pump side to equalize pressures in the vacuum pump and thus to prevent the rotary oil surging into the vacuum line.

When the power is removed, because of the use of a capacitor, the isolation valve closes with a small delay and the air admittance valve opens with the same delay (about five seconds) to admit air into the rotary pump side. This delay ensures that the backing valve is fully closed before air is admitted in order to preserve any vacuum in the diffusion pump side.

The circuit diagram for the isolation/air admittance valve is shown in Fig. 3.40.

The truth table for the isolation valve is shown in Table 3.17.

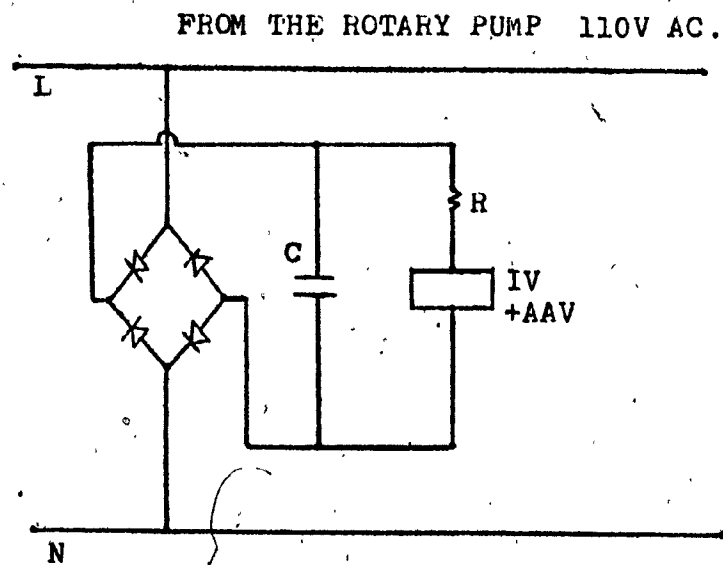

FIG. 3.40 CIRCUIT DIAGRAM FOR THE OPERATION OF THE ISOLATION/AIR ADMITTANCE VALVE.

The logic equation for the isolation valve (IV) is given by

$$\begin{aligned} \overline{\text{R.P. Power}} &= \overline{I \cdot V} \\ (\overline{\text{RLEI}} &= \overline{I \cdot V}) \end{aligned}$$

which leads to the logic diagram shown in Fig. 3.41.

Table 3.18 shows the truth table for the air admittance valve (AAV) which leads to the logic equation

$$\begin{aligned} \overline{\text{R.P. Power}} &= \text{AAV} \\ \text{or } (\overline{\text{RLEI}} &= \text{AAV}). \end{aligned}$$

The logic diagram is shown in Fig. 3.42.

### 3.15 MODIFICATION OF MODEL B5 PIRANI GAUGE TO OPERATE TWO VS9 VACUUM SWITCHES:

Model B5 Pirani gauge circuit diagram is shown in Fig. 3.43. As shown in Fig. 3.43, fixed resistor, R7, (47ohms), between K and A (=Pin3) and another fixed resistor, R8, (47ohms), between K and E (=Pin 1) form the two arms of a Wheatstone bridge circuit. When a Pirani gauge head, either backing or roughing, is selected by means of switch 1 (sw1/1), or switch 2 (sw2/1), the circuit, including the Pirani gauge, can be written as shown in Fig. 3.44. The vacuum switch VS9 is connected between point K and Pin 4, as shown in Fig. 3.44. In the existing B5 model, only one vacuum switch, VS9,

TABLE 3.17

TRUTH TABLE FOR CLOSING THE ISOLATION VALVE:

R.P.P	IV
1	1
0	0

← IV OFF. Desired condition.

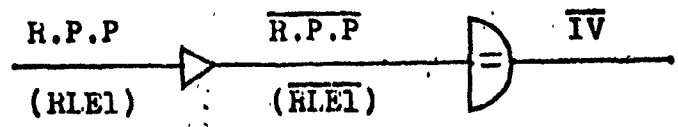

FIG. 3.41 LOGIC DIAGRAM FOR CLOSING THE ISOLATION VALVE

TABLE 3.18

TRUTH TABLE FOR THE OPENING OF THE AIR ADMITTANCE VALVE:

R.P.P	AAV
0	1 ← Desired condition
1	0

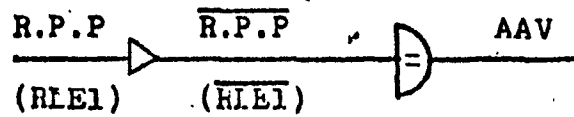
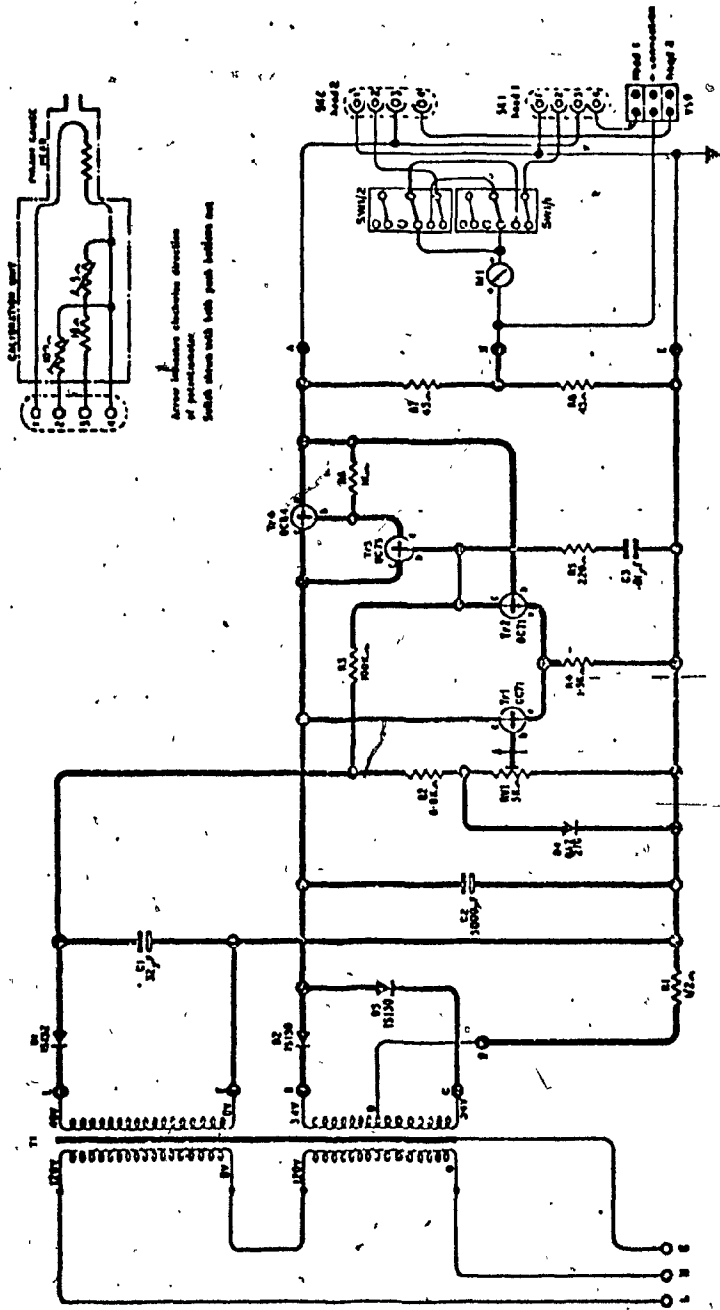

FIG. 3.42 LOGIC DIAGRAM TO OPEN THE AIR ADMITTANCE VALVE



BS PIRANI - CIRCUIT DIAGRAM

FIG. 3.43

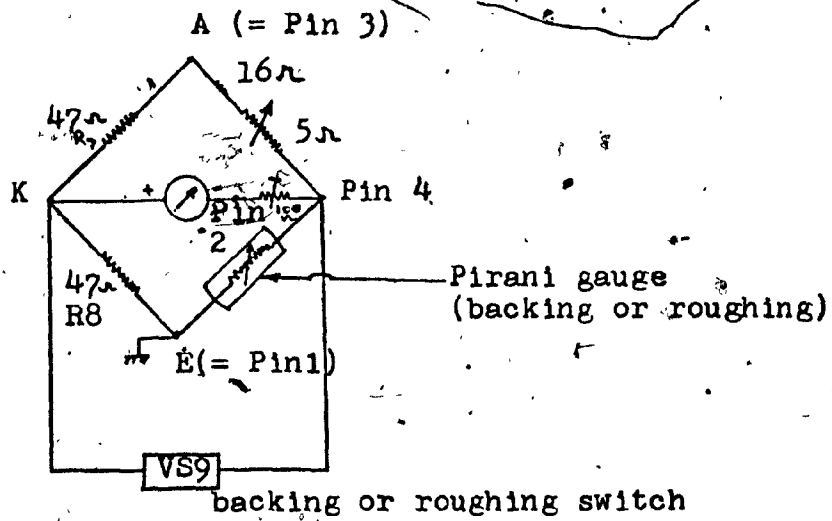

FIG. 3.44 CIRCUIT DIAGRAM SHOWING A  
 PIRANI GAUGE IN THE WHEATSTONE  
 BRIDGE NETWORK; FOR MODEL B5  
 GAUGE.

can be selected by means of the switch at a given time.

But, for this automatic vacuum system, it is necessary to connect both the vacuum switches at the same time to control the operation of the backing and roughing valves simultaneously.

Thus, the model B5 was modified as shown in Fig. 3.45 to suit this requirement by basically incorporating (1) two Pin 4 connections independent of the switches and (2) another set of 47ohms resistors between AK and KE. Thus, the backing vacuum switch VS9B is connected between K1 and backing head Pin 4, the roughing vacuum switch VS9R is connected between K2 and roughing head Pin 4 and both the VS9 vacuum switches operate independently of the B5 sw1/1 and sw2/1 switch positions.

#### 3.15.1 Basic operation of the modified B5 circuit:

When the vacuum in the roughing line is to be measured, the B5 Pirani gauge is connected to the roughing Pirani head and in the backing side, the B5 Pirani gauge, whose internal resistance is 280ohms, is replaced by an equivalent 280ohms, 1%, precision resistor. Thus, both Pirani heads and VS9 switches are connected at the same time and the roughing vacuum is read by the Pirani gauge. When it is required to measure the vacuum



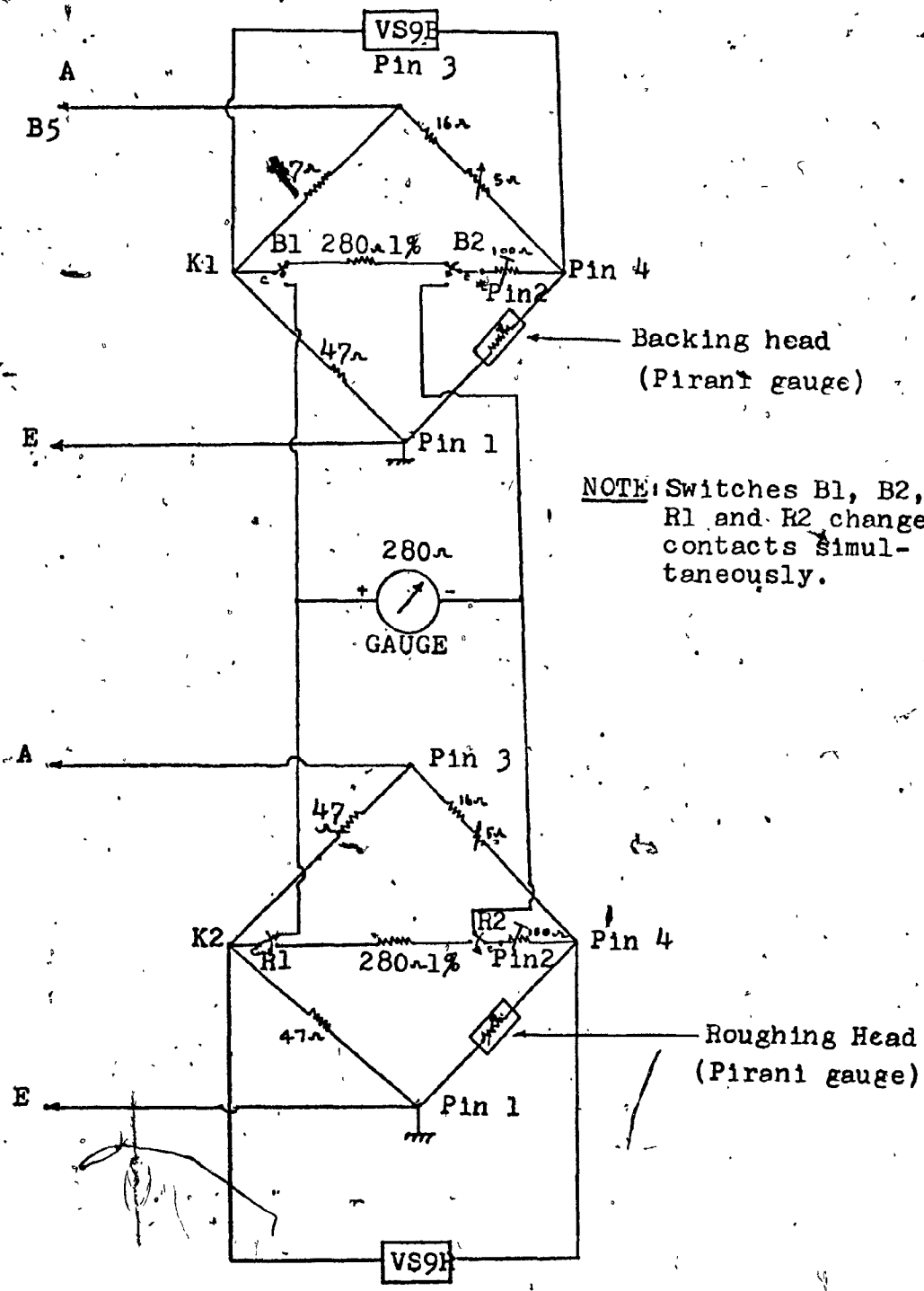

FIG. 3.45 MODIFIED B5 GAUGE TO OPERATE TWO VACUUM SWITCHES.

in the backing line, switch sw1/1 is pushed. This connects the B5 gauge to the backing head and replaces the gauge with its equivalent 280ohms, 1% precision resistor on the roughing side.

Thus, both the vacuum switches are connected all the time during the operation, regardless of the B5 switch position.

### 3.16 TIMER-CAM: DETAILS OF THE CAM DESIGN:

A cam was designed and made as shown in Fig. 3.46. The cam was fixed to a half an hour per revolution timer by means of a screw as shown in Fig. 3.47. The sense of rotation of the timer was clockwise, when viewed from the shaft side.

#### 3.16.1 DETAILS OF TIMER-CAM-MICROSWITCH OPERATION:

- a) During the first eight minutes of warm-up, the microswitch, MS1, fixed rigidly near the cam, is in the "relaxed" position. The "Normally Closed" MS1 contact closes and the relay RLB thus energizes.
- b) After eight minutes, the cam, due to its design, presses the MS1 and the "Normally Open"

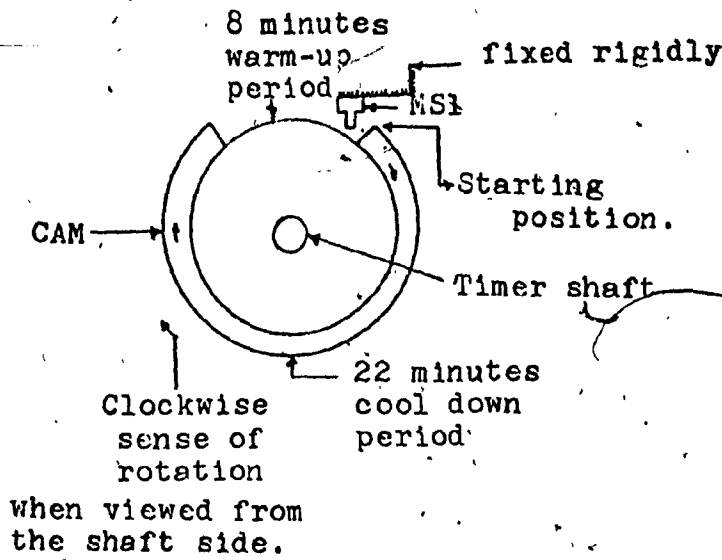

FIG. 3.46 CAM DESIGN.

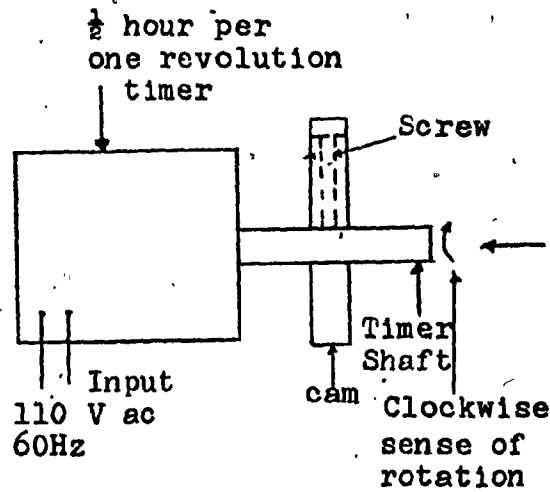

FIG. 3.47 TIMER AND CAM

contact closes. The relay HLB de-energizes and the timer stops.

- c) When the cool-down switch is pressed, the timer starts. The cam rotates with the timer, still pressing the MS1 and de-energizing the relay RLB during the twenty two minutes of cool-down period.
- d) At the end of the 22 minutes, the cam releases the pressure on the MS1, the "NO" contact changes over to "NC" and energizes the relay RLB, which causes the shut down relay to energize and switch off the whole system.
- e) To restart the next cycle, the timer-cam-MS1 arrangement follows the above steps (a to d) without any re-adjustment.

Thus, in this chapter, the details of the operation and the design of the automatic system have been explained. In the next chapter, the selection of major hardware used in this system will be described.

CHAPTER IV

MAJOR HARDWARE SELECTION

## CHAPTER IV

### MAJOR HARDWARE SELECTION

Details of various major components used in this automatic pumping system are described below:

#### 4.1 ROTARY PUMP:

A rotary pump was used basically to provide backing to the diffusion pump and to rough the chamber.

A single stage gas ballast rotary pump, model, ES35, was used. The pump is specified to give an ultimate vacuum better than 0.01 torr without using the gas ballast.

Figures (4.1) and (4.2) show the basic and the detailed features of the 'Speedivac' model ES35 pump respectively. During the operation, the air from the diffusion pump side enters the vacuum pump inlet. The two blades in the rotor sweep this volume of air and compress the air to just higher than one atmospheric pressure. The pressure causes the discharge valve to open and thus the compressed air is expelled to the atmosphere. This cycle repeats and more and more air is evacuated, thus creating a vacuum in the diffusion pump side.

A gas ballast device built-into the pump enables the

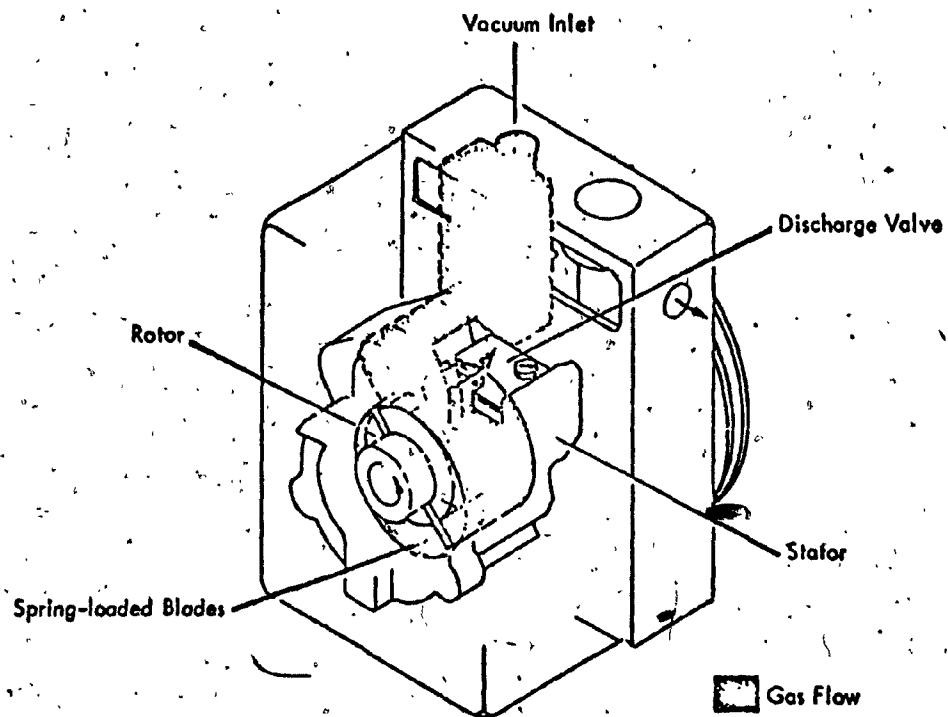

FIG. 4.1 BASIC FEATURES OF A ROTARY PUMP

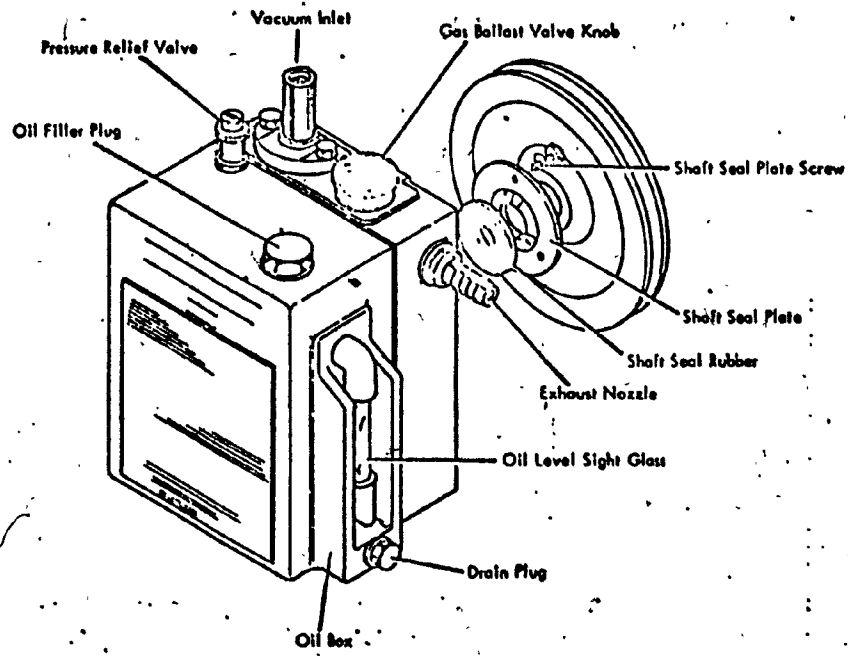

FIG. 4.2 DETAILED FEATURES OF A ROTARY PUMP



condensable vapours, if any, in the diffusion pump side to be pumped directly to the atmosphere in the vapour state, thus avoiding contamination of the interior of the pump due to condensation. By opening the gas ballast device whenever required, a quantity of air is introduced at atmospheric pressure through a one-way valve into the discharge side to increase the air to vapour ratio to prevent condensation within the pump. Thus, the gas ballast device is used at the start-up only to remove the vapour in the diffusion pump side. During the normal vacuum pumping, the gas ballast device is closed.

The pump is normally supplied with a half-an-inch coupling and a flange. 'O' rings provide metal-to-metal vacuum sealing.

#### 4.2. MAGNETICALLY OPERATED ½" ISOLATION/AIR ADMITTANCE VALVE:

A 'Speedivac' model D 2140 valve was used in this system for mounting it in the half an inch vacuum pipe line.

The valve's specifications are as follows:

Coil resistance ..... 4000 ohms.

Current (approx)..... 0.05 Amp.

Power (approx) ..... 10 Watts.

Voltage range ..... 110V to 127V a.c.

### GENERAL DESCRIPTION:

FIG. 4.3 shows the details of the valve construction.

The valve is designed for use in vacuum pumping systems for automatic isolation and air admittance to rotary pumps when it is switched off.

When the valve is switched off, the isolation valve is spring-loaded to close and the air admittance valve is designed to open. The valve is constructed such that no air can enter the system from the air admittance device during the isolation valve opening. The pressure differential against which the valve will open is dependent on the voltage applied to the valve coil. The valve is intended to open only when the differential pressure across the isolation seating is very much less than one atmosphere. This is to avoid exposing the system to a large surge of air contained in the rotary pump pipe line when the pump is switched on. The valve is mounted vertically.

### 4.3 BACKING AND ROUGHING VALVES:

Two Speedivac half-an-inch magnetic valves, model D2120 were used. One valve was used as a backing valve and the other as a roughing valve. This type of valve is intended for use as an isolation valve. Fig. 4.4 shows

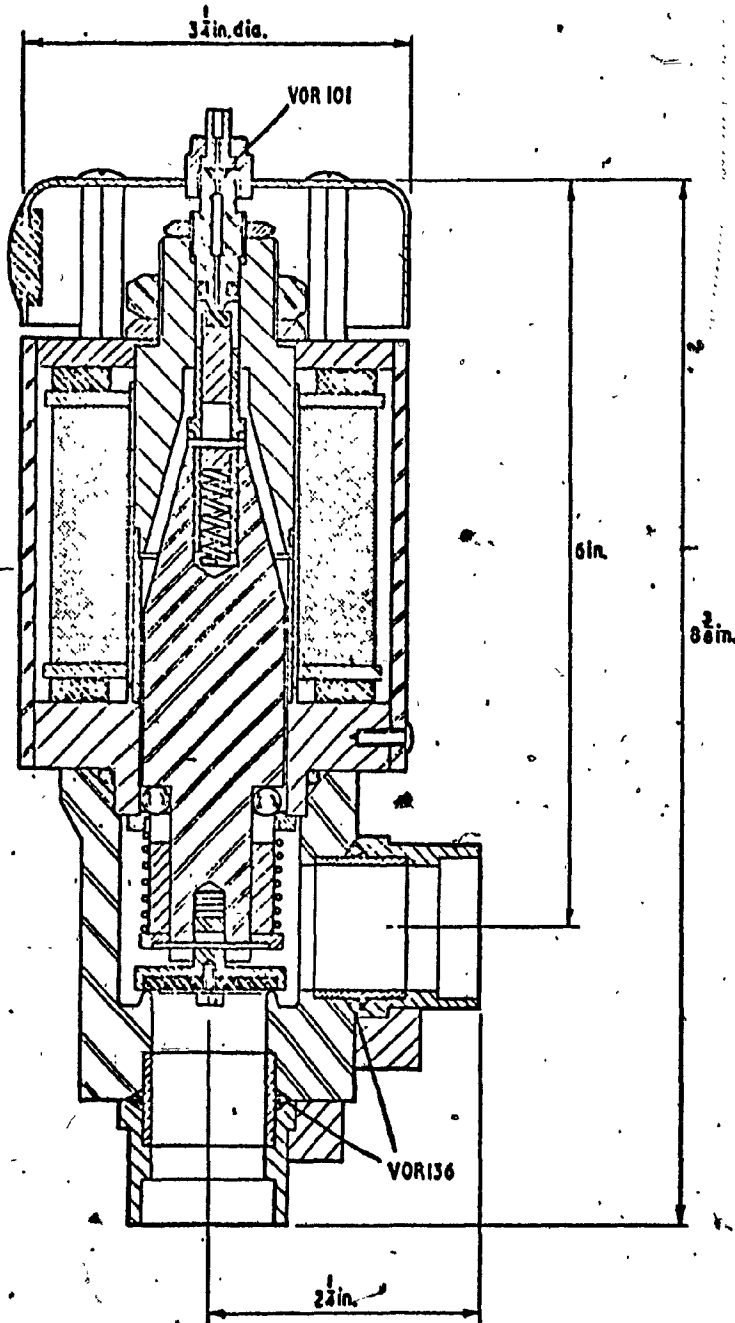

FIG. 4.3 DETAILS OF VALVE CONSTRUCTION

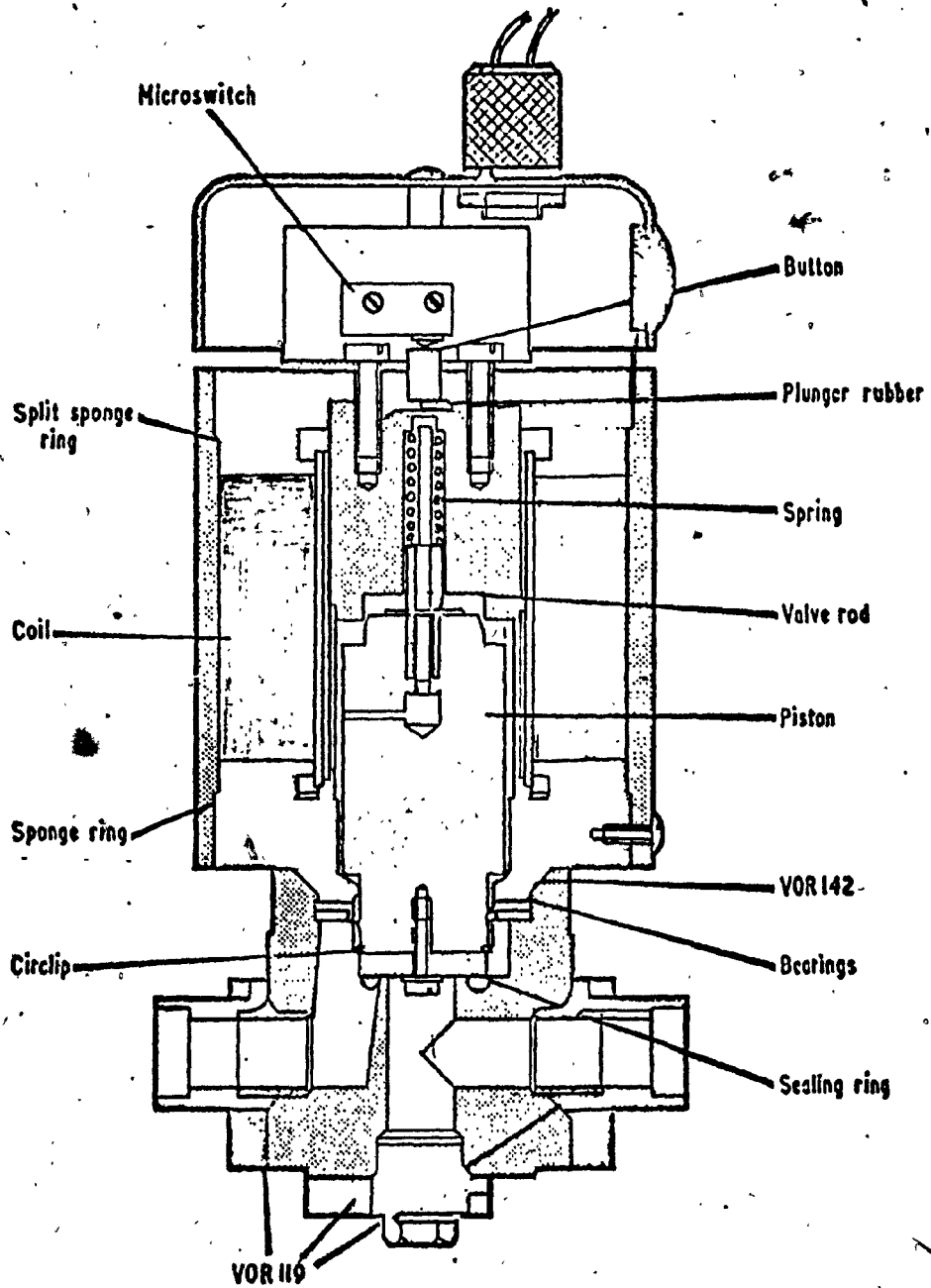

FIG. 4.4  $\frac{1}{2}$  in. MAGNETIC ISOLATION VALVE  
 [Code No D2120]

the details of the valve. Its specifications are given below:

Voltage range : 100 V to 127 V ac.

Coil resistance : Approx 800 ohms.

Current : 120 to 150 mA

Although this valve will seal against atmospheric pressure in either direction, it is connected in the system in such a manner that the pressure differential across it, when closed, assists sealing. The low pressure side of the valve has a mark B on its aluminum casting and this side is connected to the low pressure side of the vacuum system. The valve has a built-in rectifier for use on a.c. supplies. The rectifier is situated under the top cover of the valve. If a d.c. supply is used, it will be necessary to disconnect the integral rectifier.

A limit microswitch is provided at the top of the valve for external switching. The limit switch is operated by an extension on the valve plunger which strikes a rubber diaphragm. This, in turn, presses a button which operates the limit switch. The microswitch contacts are clearly marked "NO" ("Normally Open"), "NC" ("Normally Closed") and C ("Common"). When the valve is energized (open), the "NO" contact closes and the "NC" contact opens.

#### 4.4 PIRANI VACUUM GAUGE:

A Speedivac model B5 gauge was used in this system.

Its specifications are as given below:

Pressure range : 0.5 to 0.001 torr  
Electrical supply : 100 to 120 V a.c. 50 to 60Hz  
Output impedance : Better than 0.5 ohms(typical)

The working principle of a Pirani gauge is described as follows:

Pressure change in a vacuum system brings about a rise or fall in the number of gas molecules and in the thermal conductivity of the gas. When the thermal conductivity of the gas varies, the heat loss of an electrically heated constant voltage filament in the system also varies. The Pirani gauge head filament, normally made of tungsten, has a high resistance temperature co-efficient so that even a small change in system pressure brings about a measureable change in the filament resistance. The filament forms one arm of a Wheatstone bridge and the change in resistance results in an out of balance current which can be read as pressure on a meter.

#### 4.5 PIRANI GAUGE HEADS:

Two metallic gauge heads, model M6A, shown in Fig. 4.5, were used. One head was used to measure the backing pressure and the other to measure the roughing pressure.

As explained in section 3.15, the model B5 Pirani gauge has two push buttons to select the respective gauge heads.

#### 4.6 VACUUM SWITCHES:

Two vacuum switches, Speedivac model VS9, were used in association with the B5 Pirani gauge to control certain sequences of operation of the system. One switch was operated by the backing pressure and the other by the chamber pressure.

The switch does not require any head or any connection to the vacuum system and has adjustable low and high switching levels. The switch covers the full range of the Pirani gauge to which it is connected.

As explained in section 4.4, changes in the system vacuum cause voltage variations in the Pirani gauge and these same voltage operate the vacuum switch. The switch

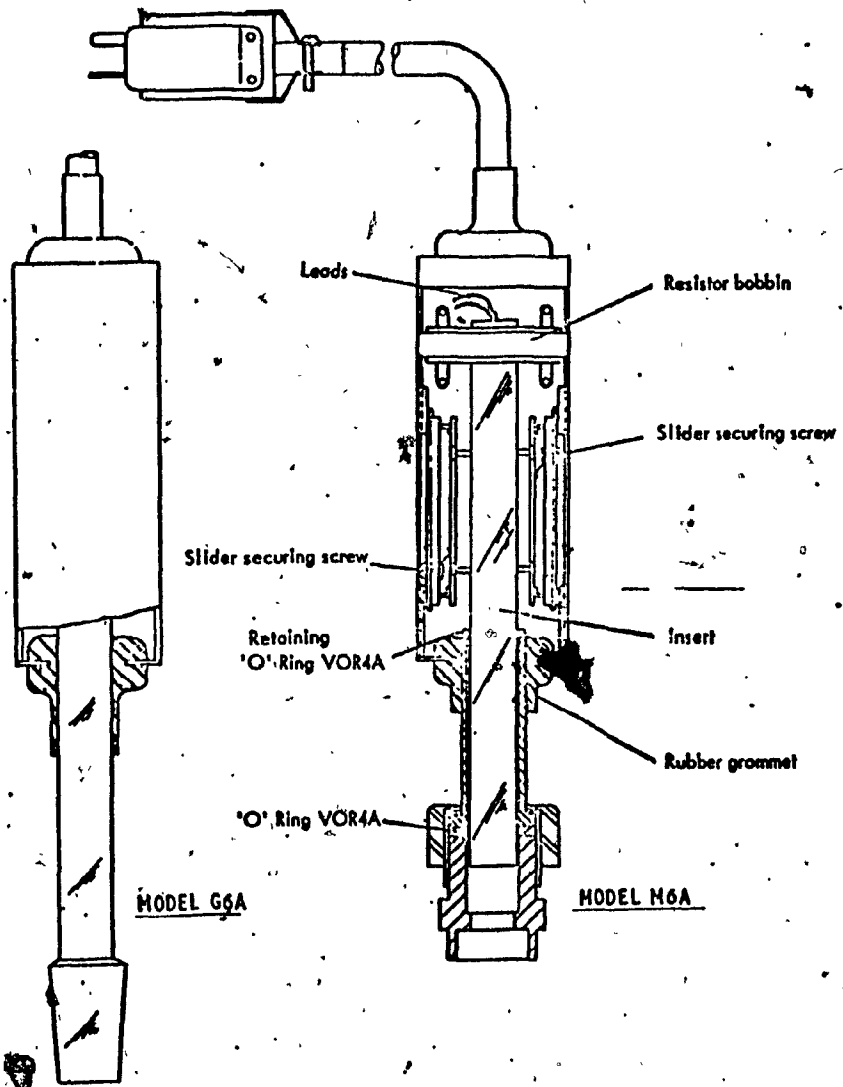

FIG. 4.5 MODELS G6A AND M6A PIRANI GAUGE HEADS



has two uncalibrated controls, LP(Low Pressure) and HP (High Pressure), on the front panel, as shown in Fig. 4.6 to select the lower and higher pressure levels, each covering the full pressure range of the Pirani gauge. The controls "LP" and "HP" can be set against the Pirani gauge readings. The input connections to the switch and the external relay contacts are shown in Fig. 4.7.

#### 4.7 DIFFUSION PUMP:

An oil diffusion pump, Speedivac model 203, was used in this system.

The specifications are:

Number of stages	: Three
Speed, at baffled value inlet	: 55litres/sec.
Ultimate vacuum using NO.702 fluid	: $5 \times 10^{-6}$ torr
Maximum backing pressure for specified ultimate at standard heater input	: 0.5 torr
Recommended speedivac pump	: ES35 or ISC50B
Fluid charge	: 50 ml
Heater loading	: 250 watts.
Water connections	: $\frac{1}{2}$ " water union
Max water flow at 15° C	: 0.4litres/min.
Baffle valve type	: 5L2

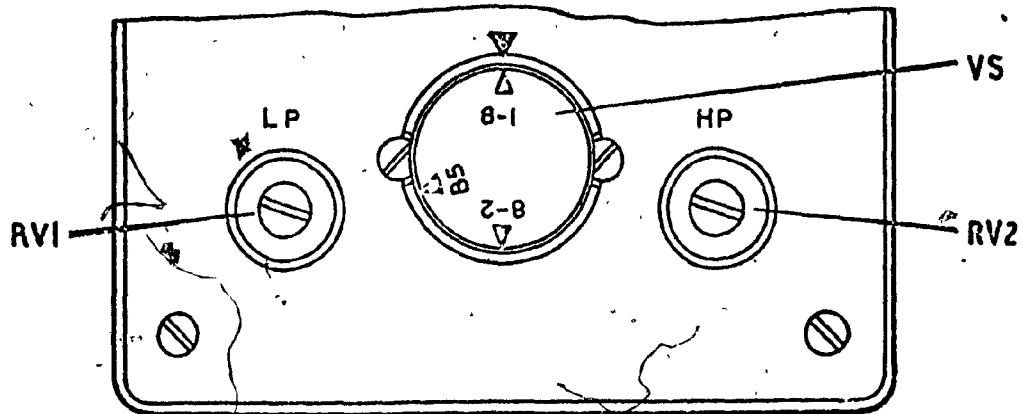

8-1, 8-2, B5 gauge selector (VS)  
 LP potentiometer (RV1)  
 HP potentiometer (RV2)

Set to match associated Pirani gauge  
 Adjusts low pressure switching point  
 Adjusts high pressure switching point

FIG. 4.6 VACUUM SWITCH VS9 FRONT PANEL.

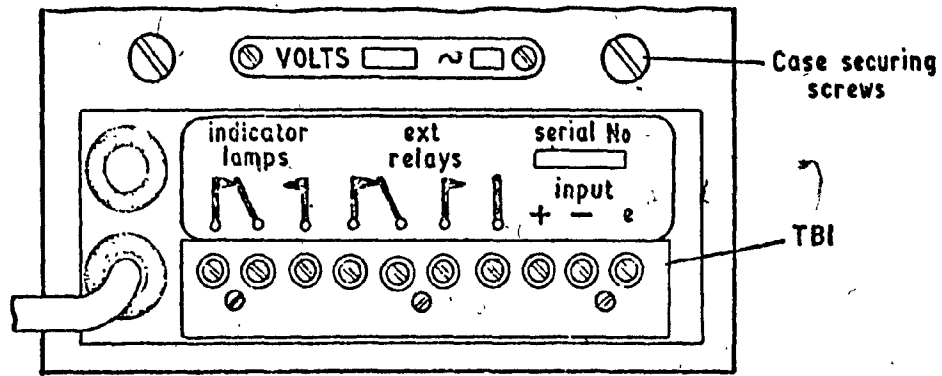

EXT. RELAYS	External use N.C. and N.O.) contacts for heavy duty apparatus	) External power supplies required
INDICATOR LAMPS	Change-over contacts for external indicator	)

The label shows the de-energized position of the relay contacts.

INPUT	+ ) - ) e )	For connection to Pirani gauge Earth connection for cable screen
-------	-------------------	---

FIG. 4.7 VACUUM SWITCH VS9 REAR PANEL.

A sketch of the diffusion pump is shown in Fig. 4.8. The basic principle of operation of an oil (or mercury) diffusion pump is given below:

The oil is boiled at backing pressure in the reservoir A and vapourises into the tube. At a suitable rate of heating, this stream impinges on the reflecting "umbrella" - shaped cone C and streams down the annular tube D. The pump is surrounded by a water jacket E so that the downward stream of oil finally condenses against the walls near the bottom of the tube D and returns to the reservoir by tube F. This tube F is U shaped so that oil collecting in it prevents direct contact between the backing pressure and the high pressure in the boiler A. The gas molecules in the space J, which is directly connected to the vessel being exhausted, diffuse into the oil stream at D and are forced to the backing pump.

#### 4.8 HIGH VACUUM VALVE(BAFFLE VALVE):

A two inch baffle valve, Speedivac model 5L2, was used. It was found at first that the valve did not make proper sealing with its base because of improper seating. Therefore, the base plate was chamfered at its end to make a proper seating which reduced the leak to a negligible amount.

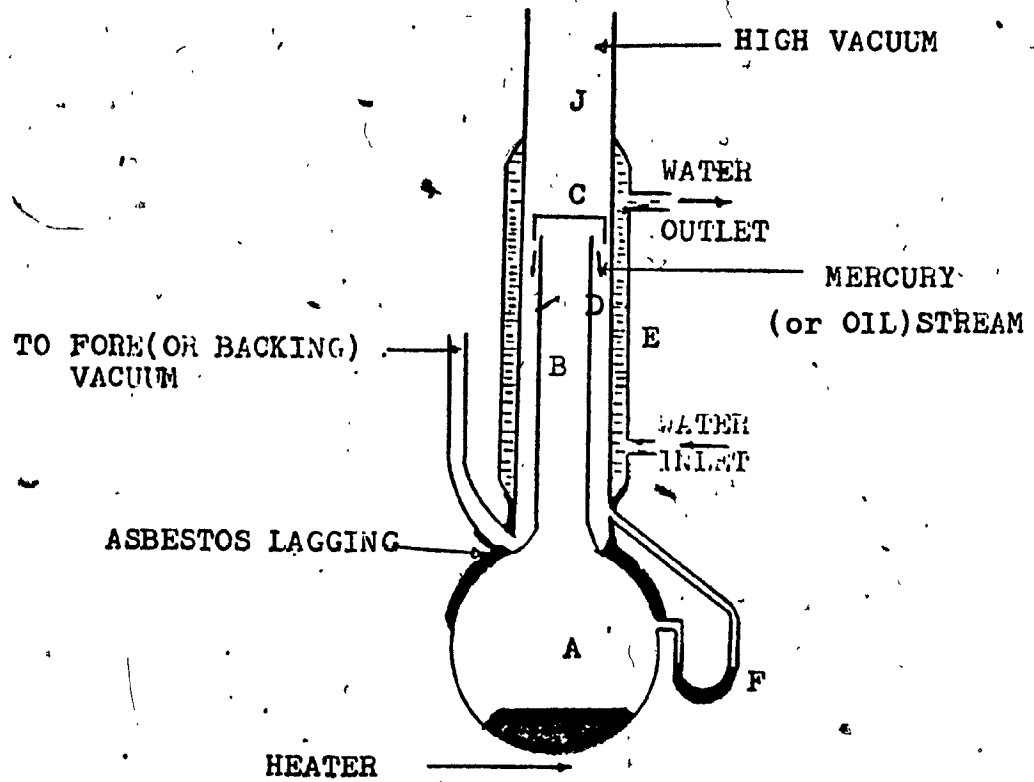

FIG. 4.8 A SKETCH OF A DIFFUSION PUMP

#### 4.9 CHAMBER AIR ADMITTANCE VALVE:

A Speedivac model OSC 1 air admittance valve was used to admit air into the work chamber.

#### 4.10 VACUUM CONNECTIONS:

Maximum exhaust speed of the pump at high vacuum can only be obtained by using the shortest length of wide bore vacuum pipe connection practicable. Long lengths of narrow bore pipes affect both pumping speed and ultimate vacuum.

Short and wide bore pipes and demountable couplings were used during the construction of the system. In order to minimize leaks, the joints were brazed and proper 'O' rings and greases were used.

#### 4.11 TIMER:

A half an hour per one revolution synchronous motor timer, made by General Control Switches and Timers & Co., was used.

4.12 RELAYS:

Potter & Brumfield telephone type d.c. relays, model BS 17D, having the following specifications, were used:

Coil voltage	:	110 V, D.C.
Coil resistance in ohms	:	6,500.
Nominal Power	:	1.8 watts.
Contact arrangement	:	4 Double pole, double throw contacts.
Continuous Current Rating	:	4 Amps

4.13 MICROSWITCHES:

Microswitch industries, Honeywell, microswitch models BZ-2RD, BZ-2RW80-A2 were used. The specifications are as follows:

BZ-2RD:

General purpose. Momentary contact action.

Compact over-travel plunger.

Ratings:  $\frac{1}{2}$  Amps, 120 V DC;

15Amps, 125 Volts a.c.

BZ-2RW80-A2:

Rigid lever. General purpose. Momentary contact action.

Ratings:  $\frac{1}{2}$  Amp, 120 V DC  
15 Amp, 125 V a.c.

An automatic vacuum pumping system was built from the major components described in this chapter. Leaks in the vacuum system were eliminated. The system was tested for the automatic operation. In the next chapter, the experience with the automatic system will be described.



CHAPTER V

EXPERIENCE WITH THE AUTOMATIC SYSTEM

CHAPTER VEXPERIENCE WITH THE AUTOMATIC SYSTEM

The experience with the automatic system is described below:

5.1 TO DELAY THE OPENING OF THE BACKING VALVE:

The reason to delay the opening of the backing valve with respect to the rotary pump starting was mentioned in section 3.6. In order to achieve this delay, a built-in rectifier in the backing valve was disconnected and a bridge rectifier and thermistors were connected in series with the backing valve. When the supply was on, only about 70 volts d.c. was applied across the valve so that it remained closed initially. Against no pressure differential across the valve, the valve opened at about 80 volts d.c. in about 8 seconds. Against atmospheric pressure differential, which is normally the case, the valve opened at about 110 V d.c. after about 38 seconds.

5.2 TO DELAY THE OPENING OF THE ROUGHING VALVE:

The importance of opening the roughing valve only after closing the backing valve was discussed in

### Section 3.8.

In actual experience, it was found that as soon as the supply was switched on to the roughing valve through the thermistors, the voltage supplied to the valve was enough to lift the piston from its seat and, therefore, there was a pressure link between the roughing and the backing lines for a short time, which caused the pressure in the backing line to rise to almost atmospheric pressure.

Therefore, in order to establish the opening and the closing times of a half-an-inch magnetic roughing valve against the input voltage, the following experiment was done:

### 5.3 EXPERIMENT TO FIND OPENING AND CLOSING TIMES AGAINST APPLIED VOLTAGE FOR A ½ INCH MAGNETIC VALVE:

#### 5.3.1 AIM:

To find out the time taken for the piston to

- a) open fully from the time the input voltage is off.
- b) lift from its seat (opening action) from the time the input voltage is applied.

- c) close from the time the input voltage is off, and
- d) close from the time the d.c input voltage is switched off.

### 5.3.2 EXPERIMENTAL CONDITIONS:

- a) The valve was held vertically and
- b) The valve was tested with atmospheric pressures at both sides so that there was no pressure differential across the valve.

### 5.3.3 EQUIPMENT USED:

- a) A  $\frac{1}{2}$  inch magnetic isolation valve, Model D2120. Input voltage range 220-240V AC, 60 Hz.
- b) A variac to vary the input voltage to the valve.
- c) One external heavy duty microswitch to indicate the movement of the piston at the bottom.
- d) A screw,  $2\frac{1}{4}$  inches long, fixed at the bottom of the piston to indicate the piston movements.
- e) A cathode ray oscilloscope to measure the time intervals.

- f) An a.c. voltmeter to measure the a.c. input voltage to the valve.
- g) A 3 volt battery, and
- h) A double pole and a wafer switches to connect or disconnect the input voltage and the 3 volt battery voltage.

#### 5.3.4 EXPERIMENTAL SET-UP:

Fig. 5. shows the experimental set up.

- a) One external microswitch, MS1, was placed at the bottom of the piston. This microswitch indicated the fully closed position of the piston and also the act of opening.
- b) A microswitch, MS2, built-in the valve, indicated the fully open position of the piston.
- c) By means of a double-pole switch, the supply and the trigger were on at the same time.
- d) A wafer switch was used to switch off the d.c. input voltage to the valve and also to connect the battery voltage at the same time.

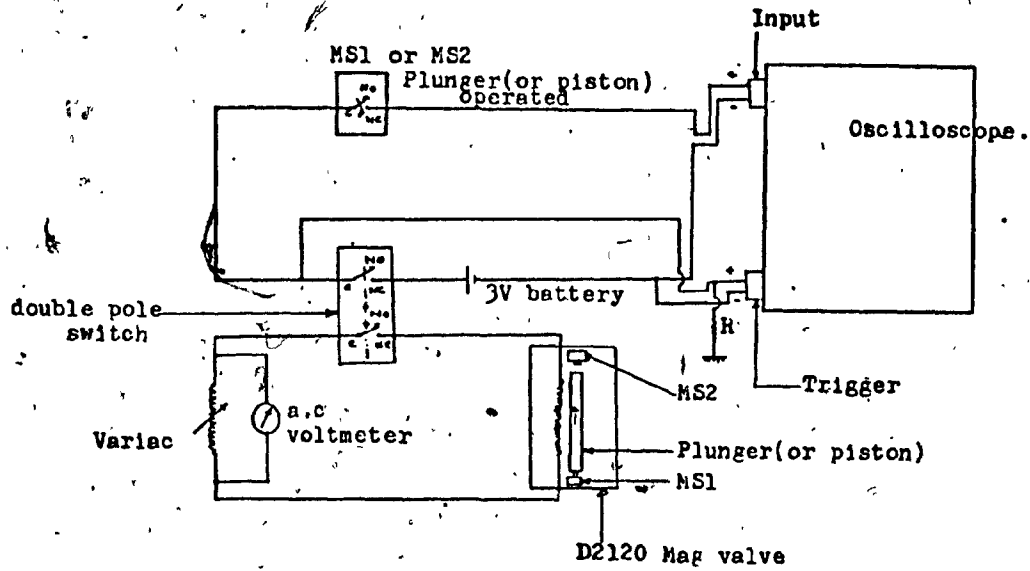

FIG. 5 SET-UP FOR A.C. SWITCHING.

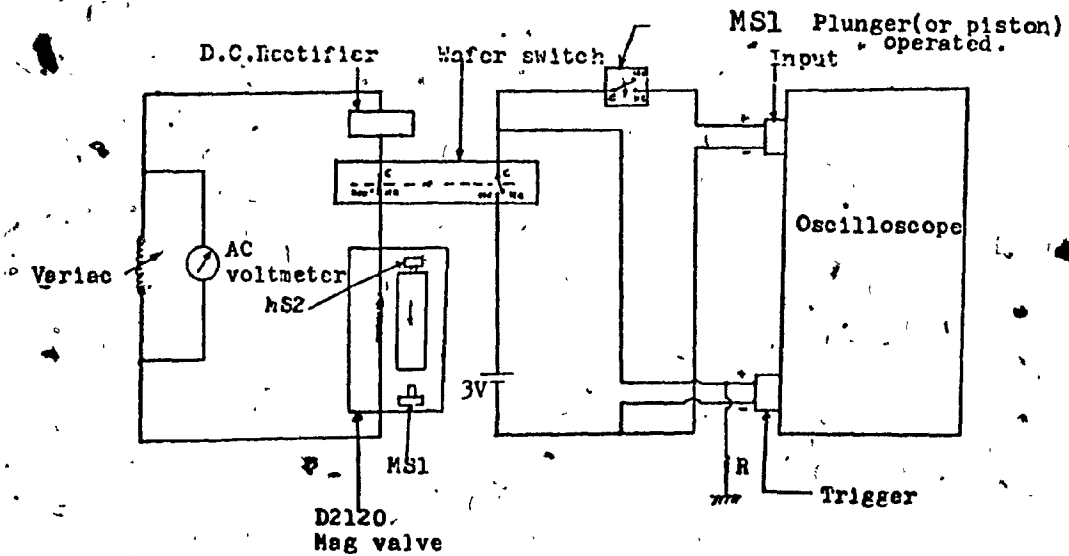

FIG. 5 SET-UP FOR D.C. SWITCHING

### 5.3.5 INTERPRETATION OF THE RESULTS:

Results were plotted in a graph as shown..

From these results, the following findings are made:..

- a) The time taken for the piston to fully open decreases as the field increases, which is logical to expect. The time taken to fully open can be divided basically into two parts: 1) time for the piston to lift from the seat (ie., the magnetic field to overcome the inertia of the piston) and 2) time for the piston to travel between the lifted position and the fully open position (ie., the field to overcome mainly the constant of the spring).
- b) The time taken for the valve to lift also decreases as the voltage increases ie., the piston travels faster as the voltage-current, in fact, increases.
- c) The piston begins to lift from the seat at about 140 volt a.c.
- d) The piston can be stopped in the middle of its travel at a suitably low voltage.
- e) The piston closes faster than it opens because the spring pushes it away.

VOLTAGE vs TIME CHARACTERISTICS OF A MAG. VALVE

(1", D7170)

SCALE: X axis: 1cm=10V a.c.

Y axis: a) 1cm=50ms

b) 1cm=10ms

- I. TIME TAKEN FOR THE PLUNGER TO OPEN FULLY FROM THE TIME SUPPLY IS ON (Scale A)
- II. TIME TAKEN FOR THE PLUNGER TO LIFT FROM THE SEAT (Opening / Closing) - SCALE A
- III. TIME TAKEN FOR THE PLUNGER TO CLOSE FROM THE TIME SUPPLY IS OFF. (Scale b)
- IV. TIME TAKEN FOR THE PLUNGER TO CLOSE WHEN D.C. IS SWITCHED OFF (Scale B).

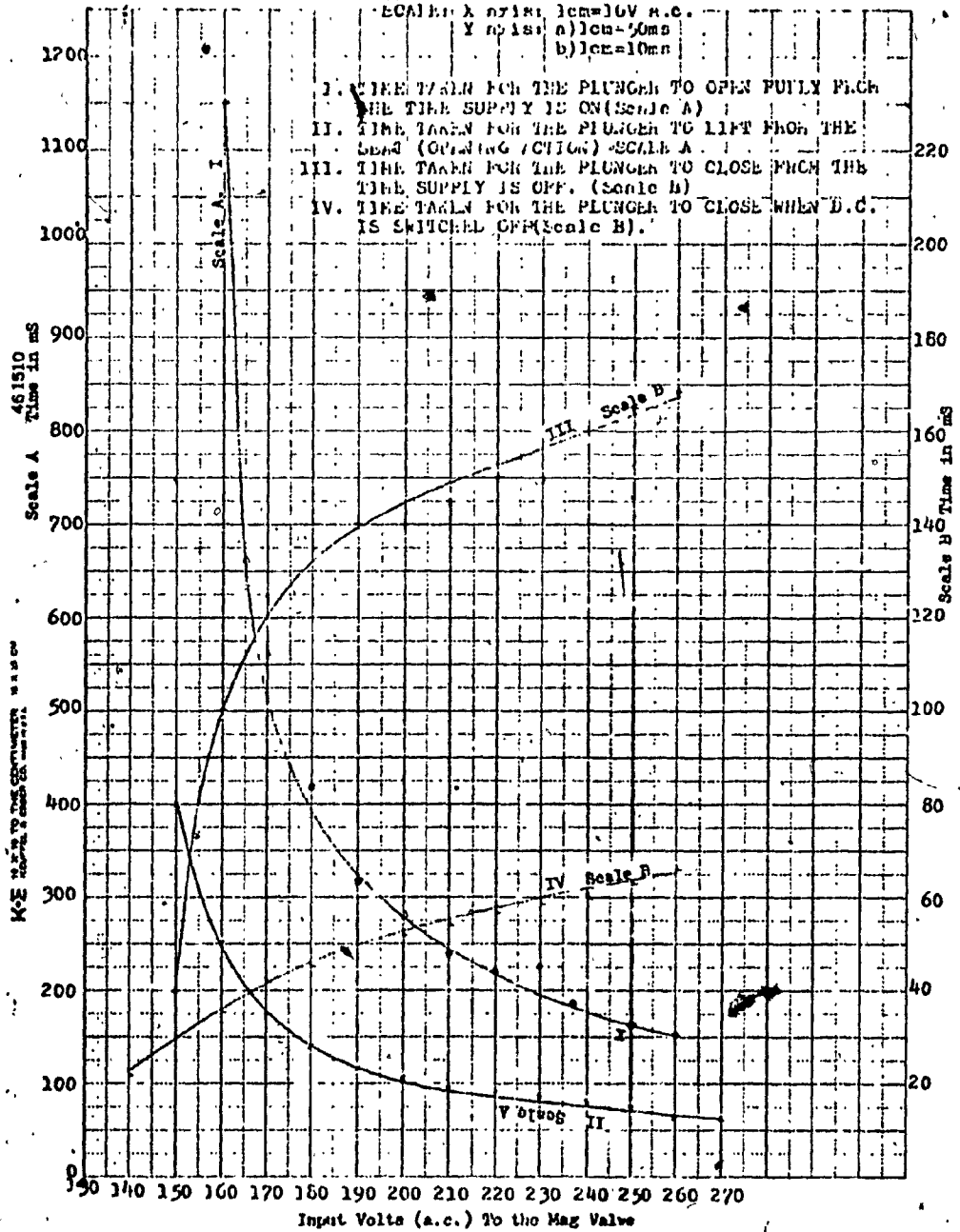



- f) The piston closes even faster when the d.c. is switched off because the field dies away almost instantaneously, and
- g) The piston will remain open until the voltage is down to 110 V a.c.

#### 5.4 TESTING THE SEQUENCES OF OPERATION:

##### 5.4.1 STARTING OPERATION:

- a) The rotary pump was switched on.
- b) The water and the isolation valves opened.
- c) The air admittance valve closed.
- d) The B5 Pirani gauge switched on.
- e) The backing valve opened after eight seconds at 85 V d.c. with no pressure differential across the backing valve.
- f) The VS9B1 switch closed after one minute and 20 seconds when the backing pressure was about 0.12 torr.
- g) The diffusion pump heater switched ON.
- h) The backing valve closed.
- i) The roughing valve opened with about 30 seconds delay.
- j) The VS9R1 switch opened after three minutes and twenty seconds when the chamber vacuum

was about 0.08 torr.

- k) The roughing valve closed.
- l) The backing valve opened with a delay of about twenty seconds at 110 V d.c.

#### 5.4.2 INTERMEDIATE OPERATION:

- a) The VS9R1 closed when the vacuum in the chamber was about 0.5 torr. It took about 5 minutes and 10 seconds to rise to this pressure.
- b) The backing valve closed.
- c) Then, the roughing valve opened.
- d) The VS9R1 opened when the pressure in the chamber was about 0.08 torr. It took about 6 minutes and 50 seconds (from the time the rotary pump was switched on) to reach this pressure.
- e) The roughing valve closed.
- f) Then, the backing valve opened. The time delay in opening the backing valve was less than four seconds at 110 V d.c. This was, perhaps, because the backing valve thermistors were still warm.

#### 5.4.3 WORK COMPLETION:

- a) The alarm bell was tested successfully by attempting to open the high vacuum valve deliberately before the timer stopped. The bell rang to warn the operator about the untimely attempt to open the valve.
- b) The timer switched off after about eight minutes.
- c) The "Ready" light came on.
- d) The high vacuum valve was opened without any alarm signal.
- e) Then, the high vacuum valve was closed.

#### 5.4.4 COOL-DOWN AND SHUT-DOWN OPERATIONS:

When the cool-down switch was pressed,

- a) The timer started.
- b) The warning light came on.
- c) The diffusion pump heater switched off.
- d) After about twenty two minutes, the rotary pump stopped.
- e) The backing and the water valves closed.
- f) The isolation valve closed and the air admittance valve opened with a delay of

about 5 seconds to admit air into the rotary pump side.

- g) All the indicator lights worked correctly during the whole operation.

The whole test was repeated twice. The sequences of operation and the timings agreed with one another.

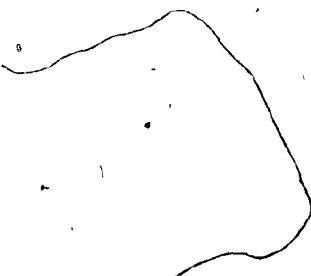

CHAPTER VI

CONCLUSION

CHAPTER VICONCLUSION

An automatic vacuum pumping system was designed, built and tested. Problem due to vacuum leaks was eliminated. The results of the tests agreed with the design and were repeatable. The automatic system was found to have trouble-free performance, required very little attention during operation and was superior in performance to a similar manual system.

REFERENCES

- 1) S. Lushman, Scientific Foundations of Vacuum Technique, London, Chapman & Hall, 1949.
- 2) I. Holland, The Vacuum Deposition of Thin Films, London, Chapman & Hall, 1956.
- 3) J. Yarwood, High Vacuum Technique, London, Chapman & Hall, 1961.
- 4) Digital Equipment Corporation, The Digital Logic Handbook, 1966-67 Edition.
- 5) General Electric Company, Transistor Manual, Seventh Edition, 1964.
- 6) Edwards High Vacuum Ltd., Crawley, Sussex, England, Manufacturer's "Speedivac" Working Instructions.
- 7) W. Steckelmacher, J. M. Parisot, I. Holland and T. Putner, "Apparatus for the controlled Deposition of Optical Film Systems", Vacuum, Volume 9, No 3/4, Pages 171-185, 1959.
- 8) A. S. Barrett and M. E. Harper, "Equipment used for Vacuum melting and casting in the Iron and Steel Industry", Journal of the Iron and Steel Institute, Volume 191, April, 1959.

- 9) W. Steckelmacher, "The Measurement of Pressure in Industrial High Vacuum Systems", Instrument Practice, May, 1960.
- 10) D. J. Crawley, "Ultra High Vacuum by means of Diffusion Pumps", The Proceedings of the Institution of Electronics, Volume 4, No. 2, 1960.
- 11) A. S. D. Barrett and M. E. Harper, "Selection of Pumping Systems for Vacuum Metallurgical Processes", Journal of the Institute of Metals, Volume 87, pp 227-234, March, 1959.
- 12) R. Murry Jr., Editor; Silicon Controlled Rectifier Designers' Handbook. Westinghouse Electric Corporation, Semiconductor Division, 1963.
- 13) A. B. Marcovitz and J.H. Pugsley, An Introduction to Switching System Design, John Willey & Sons Inc, 1971.
- 14) G.A. Maley and J. Earle, The Logic Design of Transistor-Digital Computers, Prentice Hall Inc., 1963.
- 15) J.M. Pettit and M.M. McWhorter, Electronic Switching, Timing, and Pulse Circuits, Second Edition, McGraw-Hill Book Co., 1970.



- 16) R.B. Hurley, Transistor Logic Circuits, John Wiley & Sons Inc., 1963.
- 17) I. Flores, Computer Logic : The Functional Design of Digital Computers, Pretice - Hall Inc., 1962.
- 18) D.L. Dietmeyer, Logic Design of Digital Systems, Allyn and Bacon Inc., 1971.

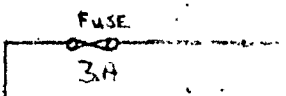

BS  
SELECTING  
SWITCH

SECTION 1

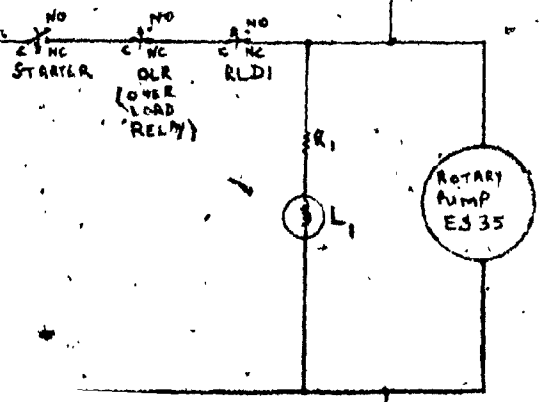

L MAINS

L ROTARY PUMP

B5  
SELECTOR  
SWITCH NO.

RLCQ  
C  
NC NO

VS9B1  
C  
NC NO

VS9R1  
C  
NC NO

MS4  
C  
NC NO  
(14)

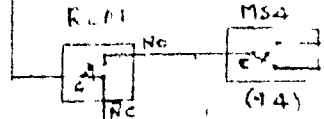
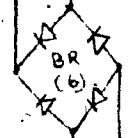
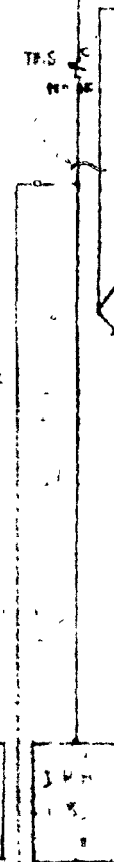
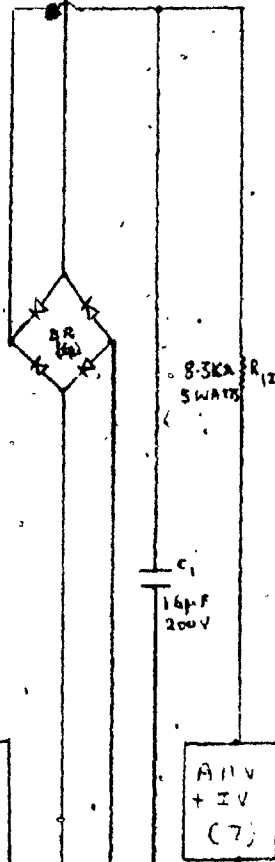
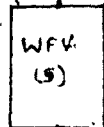
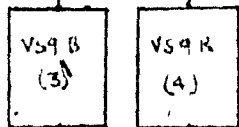
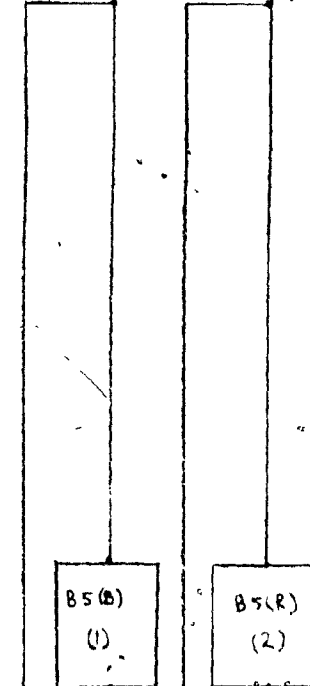

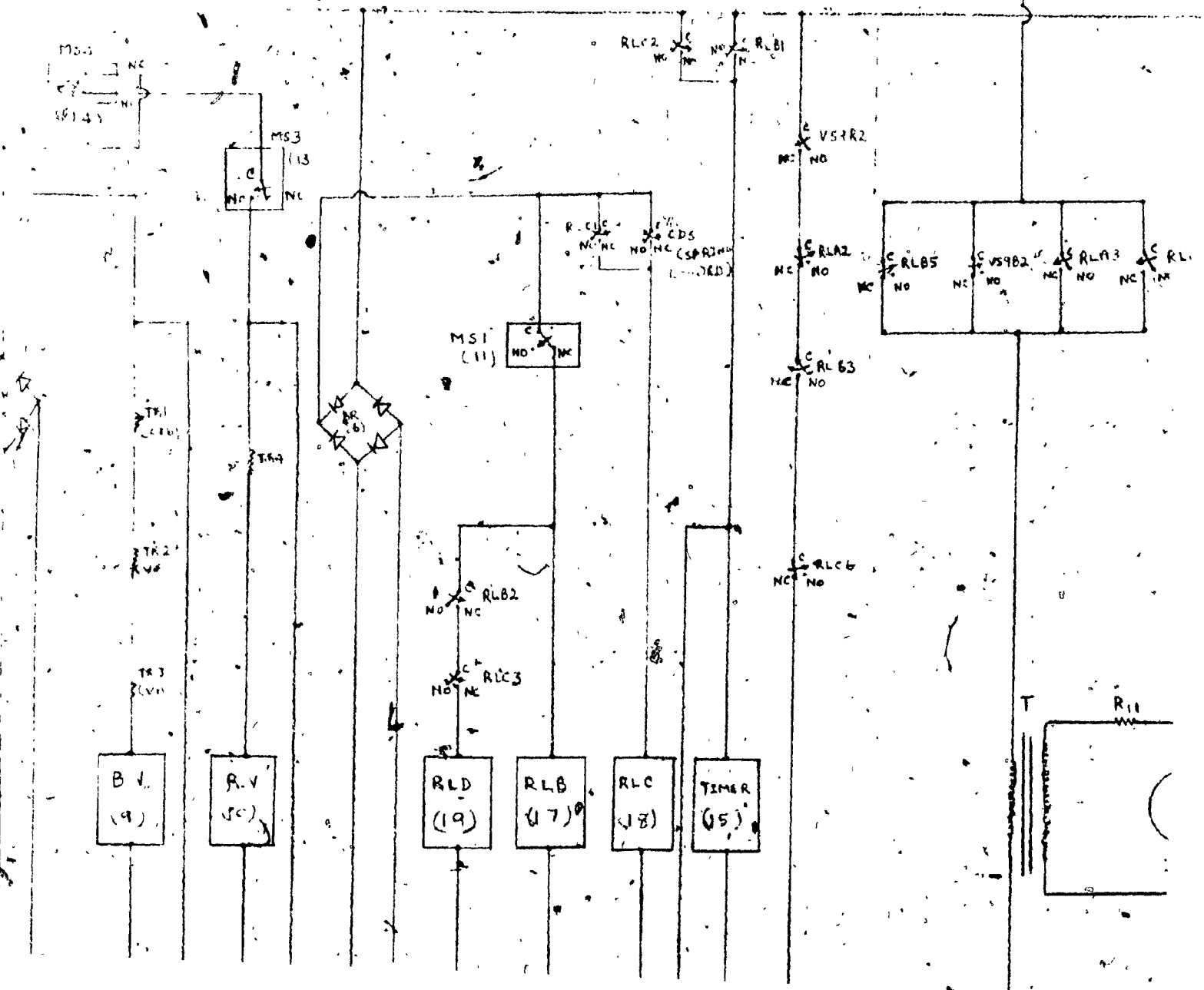

SECTION 7 - SECTION 8

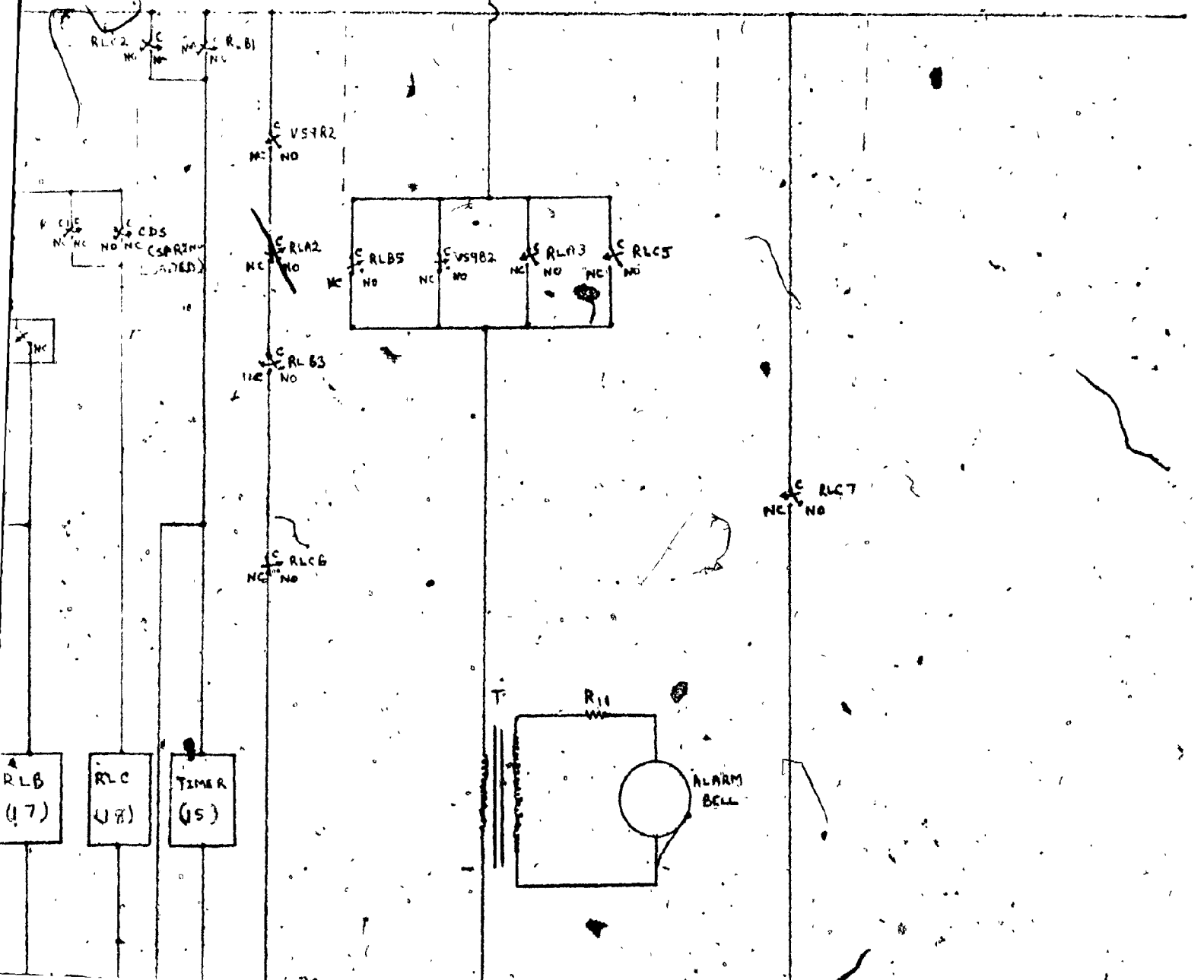

MAINS  
N

MAINS  
E.

DETAILS OF INDEXED COMPONENTS:

1	B5(B)	PIRANI GAUGE. BACKING SIDE
2	B5(R)	PIRANI GAUGE. ROUGHING SIDE.
3	VS9 B.	VACUUM SWITCH. BACKING SIDE.
4	VS9 R	VACUUM SWITCH. ROUGHING SID

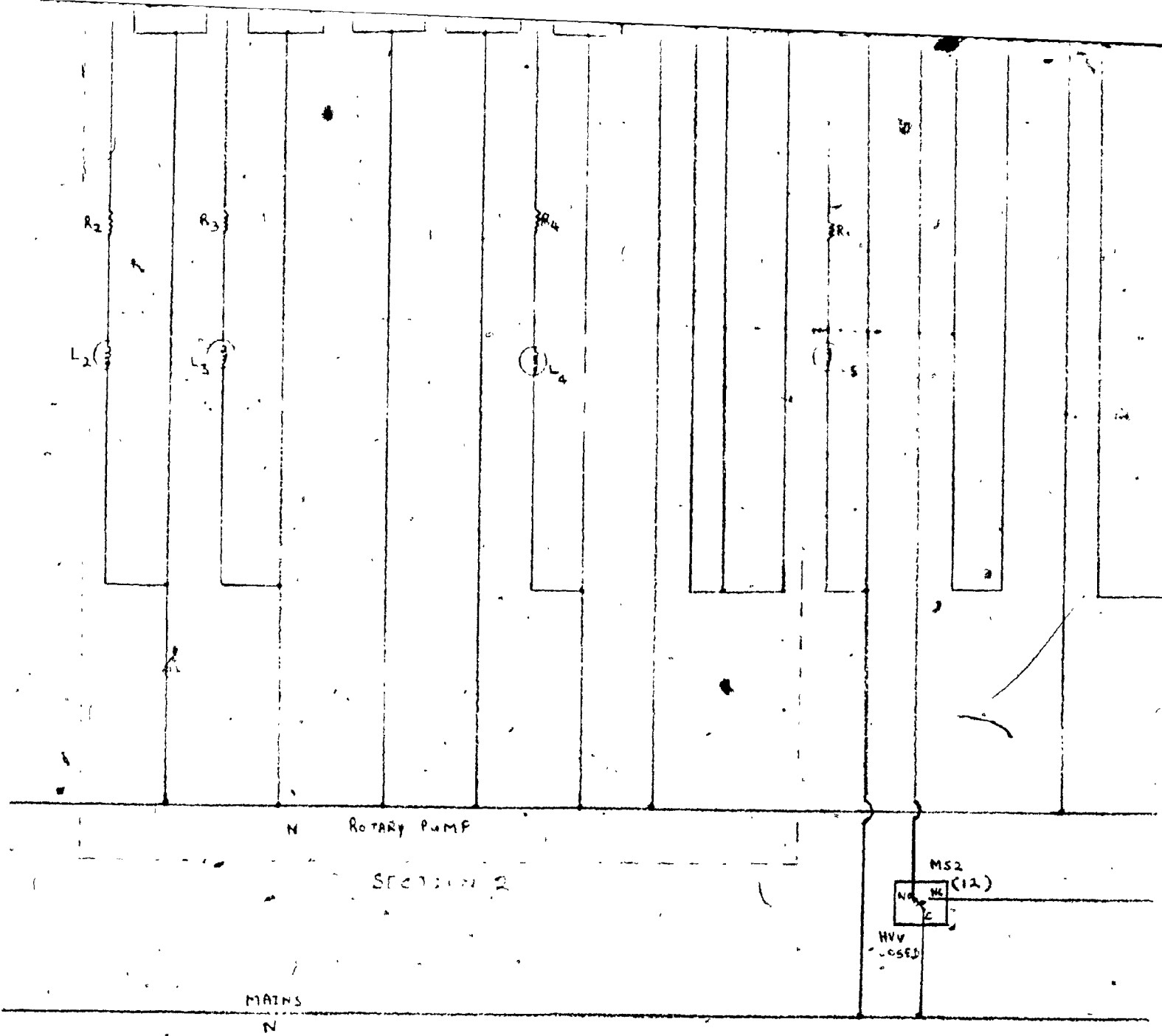
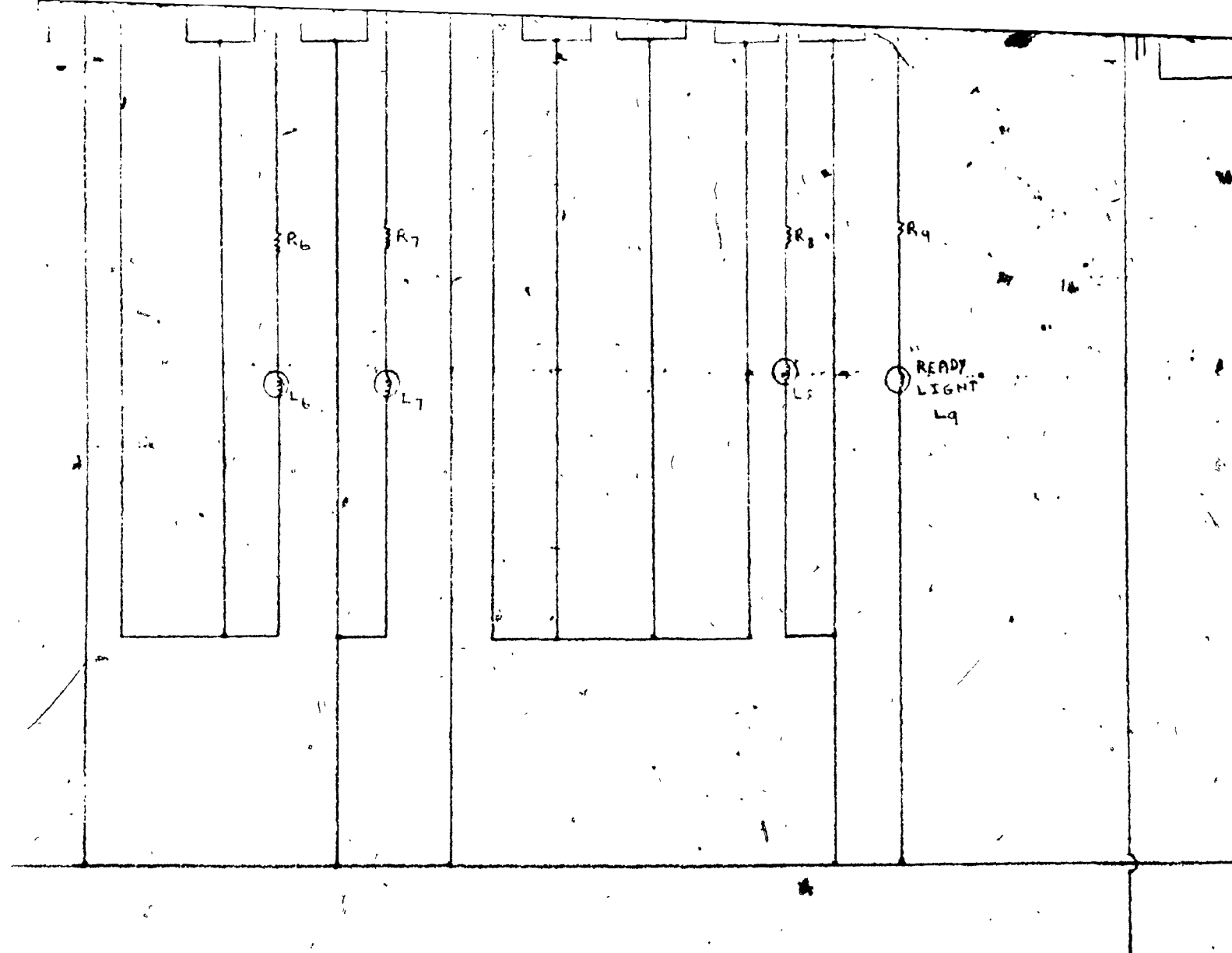

FIG 3.1. CIRCUIT DIAGRAM FOR AN AUTOMA

SIDE
SIDE.
G SIDE.
ING SIDE.

12	MS2	MICROSWITCH. HIGH VACUUM VALVE OPERATED
13	MS3	MICROSWITCH. BUILT-IN THE PUCKING VALVE.
14	MS4	MICROSWITCH. AIR ADMITTANCE
15	TIMER	1/2 HOUR / REVOLUTION
8		ORV. CHANGE-OVER RELAY



AN AUTOMATIC VACUUM PUMPING SYSTEM.

RATED VALVE



17)

J...

05

3R<sub>2</sub>

3R<sub>4</sub>

R<sub>10</sub>



READY  
LIGHT  
L<sub>9</sub>



WARNING  
LIGHT

STEM

MAINS

N

MAINS

E

DETAILS OF INDEXED COMPONENTS :

1	B5(B)	PIRANI GAUGE. BACKING SIDE
2	B5(R)	PIRANI GAUGE. ROUGHING SIDE.
3	VS9 B	VACUUM SWITCH. BACKING SIDE.
4	VS9R	VACUUM SWITCH. ROUGHING SIDE
5	WFV	WATER FLOW VALVE.
6	BR	BRIDGE RECTIFIERS.
7	AAV+IV	AIR ADMITTANCE VALVE + ISOLA VA
8	DP.H	DIFFUSION PUMP HEATER
9	B.V.	BACKING VALVE.
10	R.V	ROUGHING VALVE
11	MSI	MICROSWITCH. TIMER-CAM OPERA

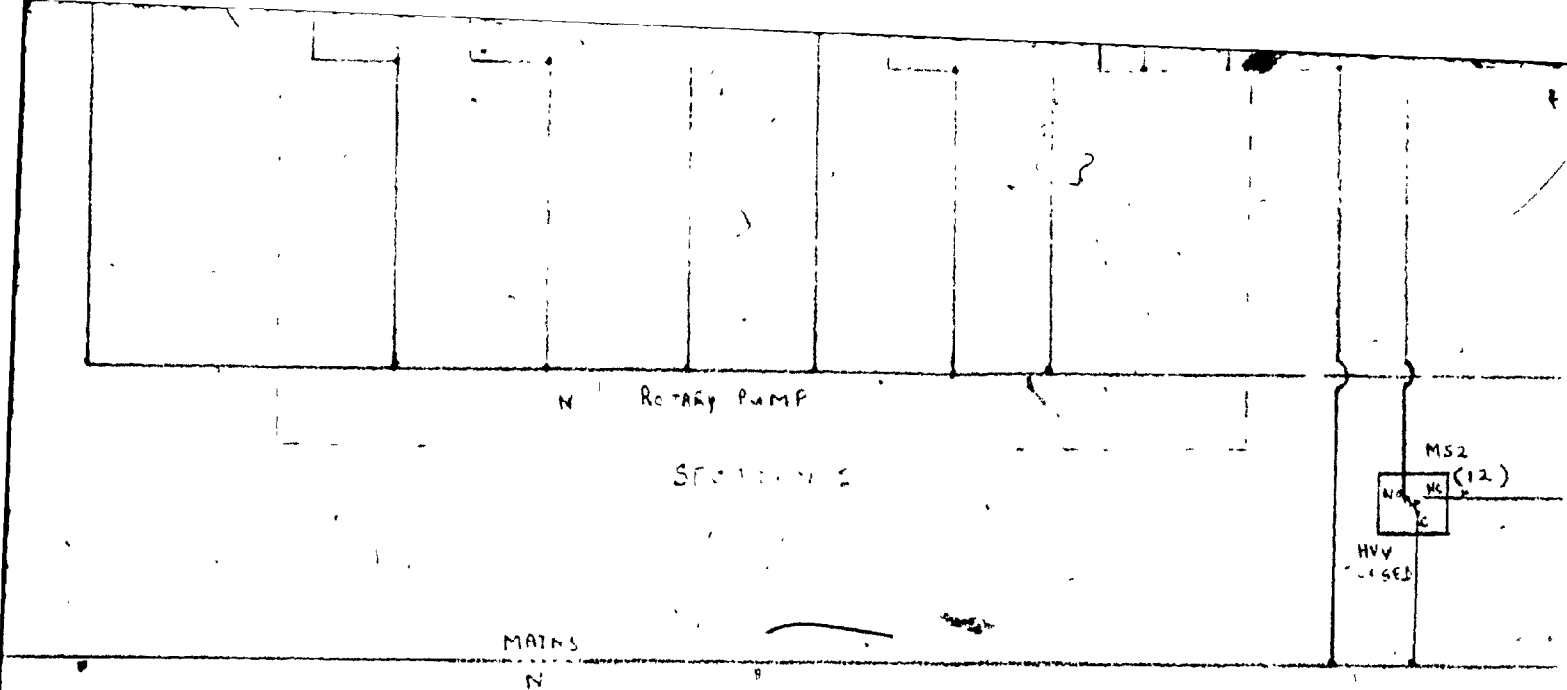
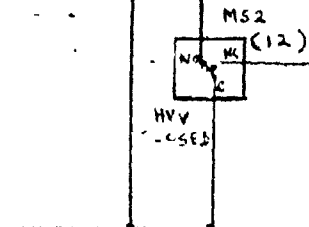

FIG 3.1. CIRCUIT DIAGRAM FOR AN

BACKING SIDE
ROUGHING SIDE.
BACKING SIDE.
H. ROUGHING SIDE.
VALVE.
FIERS.
ANCE VALVE + ISBLATION VALVE
MP HEATER
VE.
VE
TIMER-CAM OPERATED

12	MS2	MICROSWITCH. HIGH VACUUM VALVE OPERATE
13	MS3	MICROSWITCH. BUILT-IN THE BACKING VALVE
14	MS4	MICROSWITCH. AIR ADMITTANCE
15	TIMER	$\frac{1}{2}$ HOUR / REVOLUTION
16	RLA	B.V. & R.V. CHANGE-OVER RELAY
17	RLB	TIMER-CAM OPERATED RELAY
18	RLC	COOL-DOWN RELAY
19	RLD	SHUT DOWN RELAY
	R	RESISTORS
	L	RED INDICATION LIGHTS
	TR	THERMISTOR



# DIAGRAM FOR AN AUTOMATIC VACUUM PUMPING SYSTEM.

VACUUM VALVE OPERATED
-IN THE BACKING VALVE
DIFFERENCE
LIGHTS



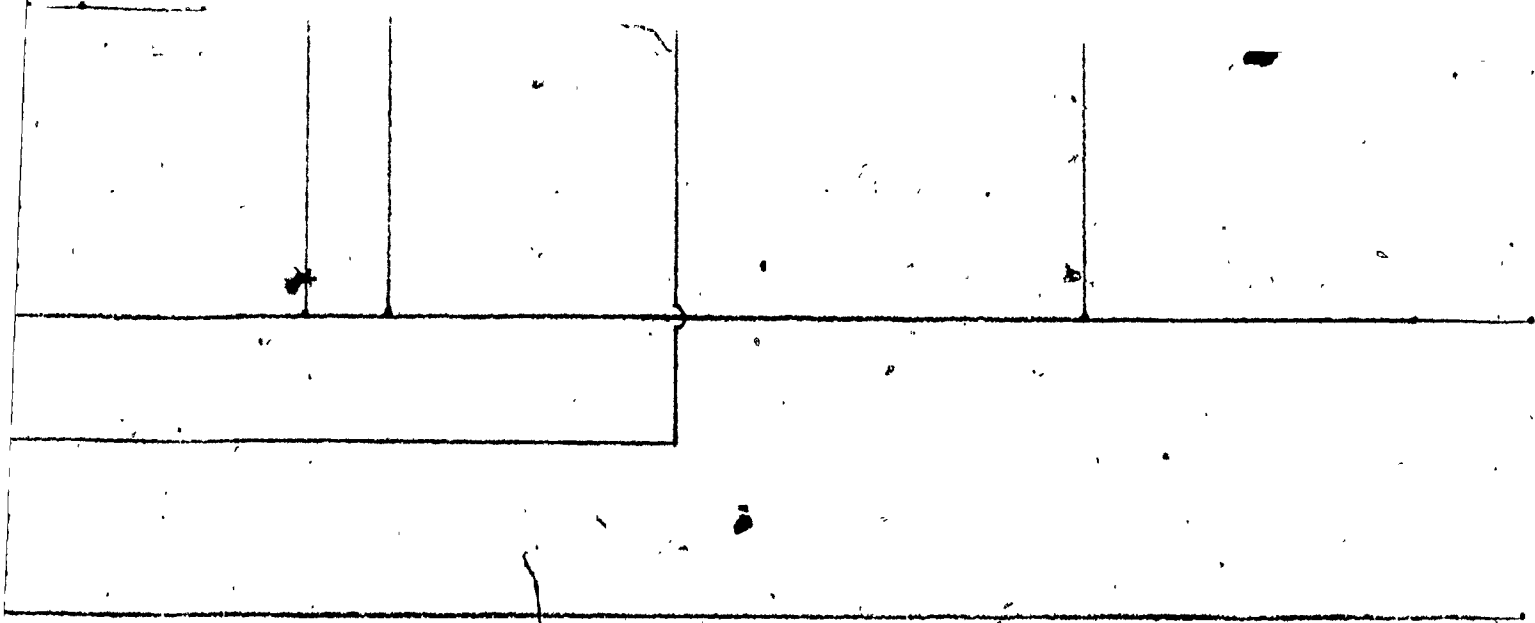

STEM

