

BACKGROUND

What has created an opportunity for recycled plastics to be used in construction?

- Continuing population explosion
- Increased price of construction materials and decreased availability of quality wood
- Municipal Solid Waste (MSW) crisis
 - 38% of MSW in Australia is from construction and demolition waste
 - Queensland alone is disposing more than 314,000 tonnes of plastics waste in landfill



GMP in civil engineering applications:



Fencing in South Australia



Seating at Xavier College, South Australia



Fort Bragg, North Carolina in 2009



Pueblo, CA in 1996

Although several commercial products on GMP have appeared in recent years, there is lack of published academic work on GMP.

Recycled mixed plastics products:

Advantages:

- Relieve pressure on landfill and forest
- Lightweight for ease of handling and installation
- Natural resistance to rot and insect attack

Disadvantages:

- Low strength
- Even lower stiffness
- Low thermal resistance
- Low UV resistance

Solution

Improve the quality and explore structural applications of recycled plastics wastes by reinforcing with short glass fibres

Comparison with other products

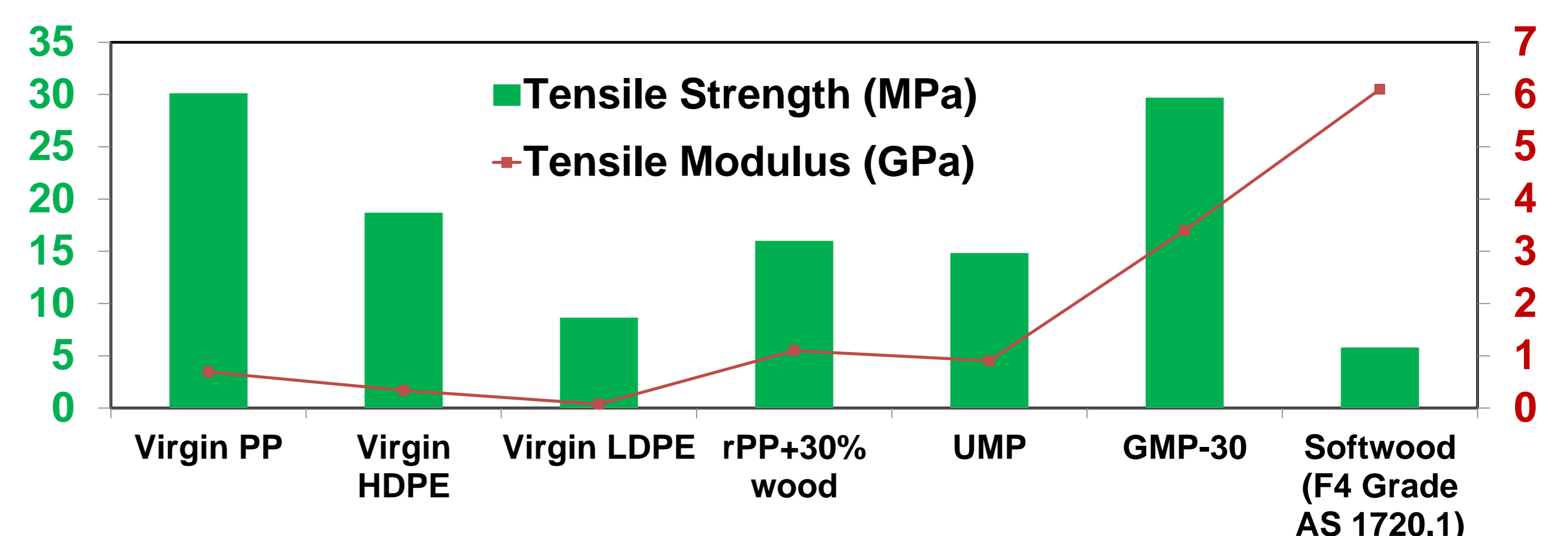

Set-up for tensile test

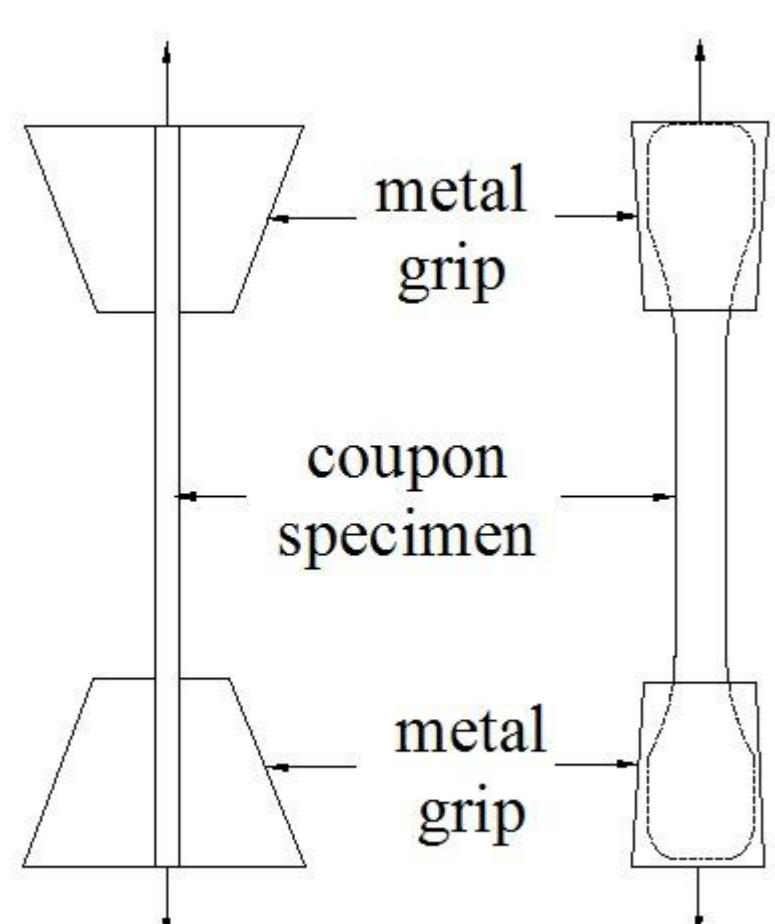

Schematic illustration



Actual test set-up

Tensile properties of GMP composites

Glass fibre content	Tensile		
	σ_t , MPa	MOE, GPa	Strain, %
0% (UMP)	14.8	0.9	12.8
10% (GMP-10)	24.71	1.8	4.4
20% (GMP-20)	24.74	2.2	3.59
30% (GMP-30)	29.7	3.4	2.48

Conclusion

Preliminary results showed that reinforcing mixed plastics waste with glass fibre results in better tensile properties than virgin and unreinforced plastics. This suggests that this new generation composite material has the high potential for construction and building applications.