

August 1963

CONTRIBUTIONS TO THE THEORY OF RANK ORDER STATISTICS

THE TWO SAMPLE CASE: FINE STRUCTURE OF THE  
ORDERING OF PROBABILITIES OF RANK ORDERS\*

I. Richard Savage and Milton Sobel

Technical Report No. 29

University of Minnesota

Minneapolis, Minnesota

\*Work done in part under contract Nonr-710(31), NR 042 003 of  
the Office of Naval Research and under Grant Number G-19126 of the  
National Science Foundation.

CONTRIBUTIONS TO THE THEORY OF RANK ORDER STATISTICS--THE TWO SAMPLE CASE:

FINE STRUCTURE OF THE ORDERING OF PROBABILITIES OF RANK ORDERS

I. Richard Savage and Milton Sobel

1. Introduction.

In constructing admissible two sample rank order tests one needs information on the ordering of probabilities of rank orders. Specifically, if, under some restriction of the class of alternatives, the rejection region of a test contains the rank order  $z$  then it should contain all rank orders more probable than  $z$ .

This paper contains several theorems on such orderings under various alternatives, especially the location parameter case for symmetric distributions.

2. Notation and Assumptions.

$X = (X_1, \dots, X_m)$  and  $Y = (Y_1, \dots, Y_n)$  are samples drawn from absolutely continuous populations with densities  $f(\cdot)$  and  $g(\cdot)$ , respectively.  $F(\cdot)$  and  $G(\cdot)$  denote the corresponding distributions.

$W = (W_1, \dots, W_{m+n})$  denotes the order statistics of the combined sample,  $(X, Y) = (X_1, \dots, X_m, Y_1, \dots, Y_n)$ , and  $Z = (Z_1, \dots, Z_{m+n})$  is a random vector of zeros and ones whose  $i$ -th component,  $Z_i$ , is 0 if  $W_i$  comes from  $f(\cdot)$  and 1 if  $W_i$  comes from  $g(\cdot)$ .

Let  $z = (z_1, \dots, z_{m+n})$  be a fixed vector of zeros and ones; we define the complement of  $z$ ,  $z^c = (z_1^c, \dots, z_{m+n}^c)$  and the transpose of  $z$ ,  $z^t = (z_1^t, \dots, z_{m+n}^t)$ , to be the vectors whose  $i$ -th components are  $1-z_i$  and  $z_{m+n+1-i}$ , respectively.  $P(z) = \Pr\{Z=z\}$  denotes the probability of the rank order  $z$ .

Since the following restrictions of  $f$  and  $g$  are assumed in several results below, we list them now along with a shorthand notation.

Restrictions:

ST:  $f(x) = f(-x)$  and  $g(x) = f(x-\theta)$ , where  $\theta$  is a non-negative constant.

U:  $f(x) \geq f(x')$  if  $0 \leq x < x'$  or  $x' < x \leq 0$ .

MLR:  $g(y)/f(y) \geq g(x)/f(x)$  if  $x \leq y$ .

N:  $f(\cdot)$  and  $g(\cdot)$  are normal densities with common variance 1 and means 0 and  $\theta$ , respectively, where  $\theta \geq 0$ .

Note: ST stands for Symmetry and Translation and U implies that  $f(\cdot)$  is Unimodal. It is assumed, without loss of generality, that the mode of  $f(\cdot)$  is the origin. MLR stands for Monotone Likelihood Ratio and N stands for Normality. Of course N is the strongest and implies the other three. Under ST and/or N we use the notations  $P(z)$  and  $P(z|\theta)$  interchangeably.

3. Theorems on the Ordering of Rank Order Probabilities.

The general expression for  $P(z)$  is

$$(3.1) \quad P(z) = m!n! \int \dots \int \prod_{i=1}^{m+n} h_{z_i}(t_i) dt_i,$$

where  $h_{z_i}(t_i) = \begin{cases} f(t_i) & z_i=0 \\ g(t_i) & z_i=1 \end{cases}$ , and the region of integration is

$-\infty < t_1 \leq \dots \leq t_{m+n} < \infty$ . In particular, under ST

$$(3.2) \quad h_{z_i}(t_i) = f(t_i - \theta z_i).$$

Theorem 1:

If ST holds, then for all  $\theta$

i)  $P(z|\theta) = P(z^t | -\theta)$  and

ii)  $P(z|\theta) = P(z^c | -\theta)$ .

Proof:

Recall the definition of  $z^t$  and  $z^c$  and note that  $f(x) = f(-x)$ . In the integral (3.1) (using (3.2)) make the transformation

$$i') \quad t_i = -t'_{m+n+1-i} \quad (i=1,2,\dots,m+n)$$

or

$$ii') \quad t_i = \theta + t'_i \quad (i=1,2,\dots,m+n)$$

and i) or ii) follows at once.

Theorem 2:

If ST holds, then for all  $\theta$

$$P(z|\theta) = P(z^{tc}|\theta). \quad (\text{See Savage (1957) p. 975.})$$

Proof:

Note that  $z^{tc} = (z^t)^c$ . Thus, by Theorem 1,

$$P(z^{tc}|\theta) = P(z^t|-\theta) = P(z|\theta).$$

Remark

If a result of the form  $P(z|\theta) \geq P(z'|\theta)$  for  $\theta \in \Gamma$  is true under ST, then, by Theorem 2, the following are also true when  $\theta \in \Gamma$ :

$$P(z^{tc}|\theta) \geq P(z'|\theta)$$

$$P(z^{tc}|\theta) \geq P((z')^{tc}|\theta)$$

$$\therefore P(z|\theta) \geq P((z')^{tc}|\theta) .$$

Theorem 3:

If MLR holds and  $z$  and  $z'$  differ only in their  $i^{\text{th}}$  and  $j^{\text{th}}$  components ( $i < j$ ) with  $(z_i, z_j) = (0, 1)$  while  $(z'_i, z'_j) = (1, 0)$ , then  $P(z) \geq P(z')$ .  
(See Savage (1956) p. 594.)

### Remark

If  $z$  and  $z'$  have a common number of zeros and ones and are such that

$\sum_{j=1}^i (z'_j - z_j) \geq 0$ , for  $i=1, \dots, m+n$ , then there exist  $z^1, z^2, \dots, z^p$ , where  
 $z^k = (z_1^k, z_2^k, \dots, z_{m+n}^k)$  for  $k=1, \dots, p$  and  $z^1 = z'$ ,  $z^p = z$ , such that for  $k=2, \dots, p$ ,  
 $z^{k-1}$  and  $z^k$  differ in exactly two components,  $i_k$  and  $j_k$  ( $i_k < j_k$ ) with  
 $(z_{i_k}^k, z_{j_k}^k) = (0, 1)$  and  $(z_{i_k}^{k-1}, z_{j_k}^{k-1}) = (1, 0)$ .

For example:

$$\begin{aligned} z &= z^4 = (0, 0, 1, 0, 1, 0, 1) \\ z^3 &= (0, 0, 1, 0, 1, 1, 0) \\ z^2 &= (0, 0, 1, 1, 0, 1, 0) \\ z' &= z^1 = (0, 1, 0, 1, 0, 1, 0) . \end{aligned}$$

Therefore we have the following result.

### Corollary:

If MLR holds and  $z$  and  $z'$  have the same number of zeros and ones and are such that  $\sum_{j=1}^i (z'_j - z_j) \geq 0$ , for  $i=1, \dots, m+n$ , then  $P(z) \geq P(z')$ . The properties of the orderings implied by Theorem 3 are discussed in detail in Savage (1962).

In succeeding pages we employ the notation  $(z, w)$ , where  $w = (w_1, \dots, w_{p+q})$  and  $z = (z_1, \dots, z_{m+n})$ , to denote the combined vector  $(z_1, \dots, z_{m+n}, w_1, \dots, w_{p+q})$ .

### Theorem 4:

If ST and U hold,  $\theta \geq 0$ , and  $z$  contains the same number,  $r$ , of zeros and ones, then

i)  $P(0, 0, 1, z^{tc}) \geq P(z, 0, 0, 1)$

and

ii)  $P(1, 0, 0, z^{tc}) \geq P(z, 1, 0, 0)$  .

Proof:

i) By Theorem 1, a necessary and sufficient condition for the conclusion is that

$$P(z,0,1,1) \geq P(z,0,0,1) ,$$

which, by (3.1) and (3.2) is equivalent to the inequality

$$(3.3) \quad I = \int_{-\infty}^{\infty} H(x) F(\theta-x)[f(x-\theta)-f(x)]dx \geq 0, \quad \text{for all } \theta \geq 0,$$

$$\text{where } H(x) = (r+2)!(r+1)! \int_{-\infty}^{\cdot} \cdot \cdot \cdot \int_{-\infty}^{\cdot} \prod_{i=1}^{2r} f(t_i - z_i \theta) dt_i f(t_{2r+1}) dt_{2r+1} .$$

We note here for future use that

$$(3.4) \quad \begin{aligned} H'(x) &= \frac{d}{dx} H(x) \\ &= f(x)(r+1)!(r+2)! \int_{-\infty}^{\cdot} \cdot \cdot \cdot \int_{-\infty}^{\cdot} \prod_{i=1}^{2r} f(t_i - \theta z_i) dt_i \\ &= f(x) G(x), \text{ say.} \end{aligned}$$

Let  $i(x)$  denote the integrand in (3.3) and let

$$I_1 = \int_{\theta/2}^{\infty} i(x)dx , \quad I_2 = \int_{-\infty}^{\theta/2} i(x)dx .$$

In  $I_2$  make the change of variable  $x = \theta - x'$ . This yields, after replacing  $x'$  by  $x$  in the transformed  $I_2$  and adding  $I_1$  and  $I_2$ ,

$$I = \int_{\theta/2}^{\infty} \left[ \frac{H(x)}{F(x)} - \frac{H(\theta-x)}{F(\theta-x)} \right] F(x) F(\theta-x)[f(x-\theta)-f(x)]dx .$$

It is easily seen that STU implies  $[f(x-\theta)-f(x)] \geq 0$  for  $x \geq \theta/2$ .

Therefore, a sufficient condition for I to be non-negative is that

$$\frac{H(x)}{F(x)} \geq \frac{H(\theta-x)}{F(\theta-x)} \quad \text{for } x \geq \theta/2.$$

Since  $x \geq \theta/2$  implies  $x \geq \theta-x$  it suffices to show that  $\frac{H(x)}{F(x)}$  is non-decreasing for all  $x$ . And for this to be true it is sufficient that  $\frac{H(x)}{F(x)}$  has a non-negative derivative, i.e., that

$$H'(x)F(x) - H(x)f(x) \geq 0$$

or, by (3.4), that

$$G(x)F(x) - H(x) \geq 0.$$

Since  $G(x)F(x) - H(x) = 0$  at  $x = -\infty$  it suffices to show that  $G(x)F(x) - H(x)$  is non-decreasing for all  $x$ , or that

$$G'(x)F(x) + f(x)G(x) - H'(x) \geq 0$$

or, by (3.4), that

$$G'(x) \geq 0,$$

which is clearly so.

ii) The proof is identical with that of i) with the following trivial modification: (3.3) is replaced by

$$I = \int_{-\infty}^{\infty} H_1(x)F(-x)[f(x-\theta)-f(x)]dx \geq 0, \quad \text{for all } \theta \geq 0,$$

where  $H(x) = (r+2)!(r+1)! \int_{-\infty < t_1 \leq \dots \leq t_{2r+1} \leq x} \prod_{i=1}^{2r} f(t_i - z_i \theta) dt_i f(t_{2r+1} - \theta) dt_{2r+1}$ .

The proofs of the next three theorems have several features in common which

we note here. They all state that if  $N$  holds then  $P(z) \geq P(z')$ . Equivalent conclusions are  $P(z^{tc}) \geq P(z')$  and  $P(z) \geq P(z'^{tc})$ ; one or the other is noted in each theorem and is in fact what is proved.

The first step is to replace each  $P(\cdot)$  with its equivalent under (3.1) and (3.2) and to change the order of integration so that a particular pair of variables is integrated last. For the convenience of the reader this pair of variables will be indicated by adding primes (') to the corresponding entries in the  $z$ -vectors the first time they appear.

At this point we have an inequality of the form

$$\int_{-\infty}^{\infty} \int_x^{\infty} S(x, y) dy dx \geq 0$$

as a necessary and sufficient condition for the inequality  $P(z) \geq P(z')$ . By making the transformation  $y-x' = w$ ,  $x = x'$  we obtain the equivalent inequality (omitting primes)

$$\int_0^{\infty} \int_{-\infty}^{\infty} S(x, x+w) dx dw \geq 0.$$

A sufficient condition for this inequality is that the inner integral is non-negative for  $w \geq 0$ , i.e., that

$$I(w) = \int_{-\infty}^{\infty} S(x, x+w) dx \geq 0,$$

for  $w \geq 0$ .

$$\text{Let } I_1(w) = \int_{-\infty}^{(\theta-w)/2} S(x, x+w) dx \text{ and } I_2(w) = I(w) - I_1(w). \text{ In } I_1(w)$$

make the transformation  $x' = \theta - x - w$ ; this makes the ranges of integration of



$I_1(w)$  and  $I_2(w)$  coincide.

By adding  $I_1(w)$  and  $I_2(w)$ , we obtain

$$I(w) = \int_{(\theta-w)/2}^{\infty} T(x, w) dx,$$

where  $T(x, w) = [S(x; x+w) + S(\theta-x-w; \theta-x)]$ .

In each case we show that  $T(x, w) \geq 0$  for  $x \geq (\theta-w)/2$  and  $w \geq 0$ , which, of course, implies  $I(w) \geq 0$  for  $w \geq 0$ .

In the proof of Theorem 5 we shall repeat in detail the argument just outlined. By Theorem 1.i it is necessary to consider only  $\theta > 0$  in proving Theorems 5 and 6.

Theorem 5:

If N holds and  $\theta \neq 0$ , then  $P(1, 0, 0^r, 0, 1) > P(0, 1, 0^r, 1, 0)$  or, equivalently,  $P(1, 0', 0^r, 0', 1) > P(1, 0', 1^r, 0', 1)$ . ( $x^r$  denotes a vector of  $r$   $x$ 's.)

Proof:

By (3.1) and (3.2), the inequality

$$P(1, 0, 0^r, 0, 1) - P(1, 0, 1^r, 0, 1) \geq 0$$

is equivalent to the inequality

$$\int_{-\infty < t_1 \leq \dots \leq t_{r+4} < \infty} f(t_1 - \theta) f(t_2) f(t_{r+3}) f(t_{r+4} - \theta) \left[ \prod_{i=3}^{r+3} f(t_i) - \prod_{i=3}^{r+2} f(t_i - \theta) \right] dt_1 \dots dt_{r+4} \geq 0.$$

Integration of the above with respect to all the variables but  $t_2$  and  $t_{r+3}$  (call them  $x$  and  $y$ , respectively), yields the equivalent inequality

$$\int_{-\infty}^{\infty} \int_x^{\infty} F(x - \theta) F(\theta - y) \{ [F(y) - F(x)]^r - [F(y - \theta) - F(x - \theta)]^r \} f(x) f(y) dy dx \geq 0.$$

If we transform the integral by letting  $x = x'$  and  $y = x'+w$  and drop the primes we get the inequality

$$(3.5) \quad \int_0^{\infty} \int_{-\infty}^{\infty} F(x-\theta)F(\theta-x-w) \{ [F(x+w)-F(x)]^F - [F(x+w-\theta)-F(x-\theta)]^F \} f(x+w)f(x) dx dw \geq 0.$$

Let  $I(w)$  denote the inner integral. If  $I(w) \geq 0$  for all  $w \geq 0$ , then it is clearly so that  $\int_0^{\infty} I(w) dw \geq 0$ , therefore a sufficient condition for (3.5)

(hence for the conclusion of the theorem) is that  $I(w) \geq 0$  for  $w \geq 0$ .

Let  $S(w, x)$  be the integrand in (3.5). Then

$$I(w) = \int_{(\theta-w)/2}^{\infty} S(w, x) dx + \int_{-\infty}^{(\theta-w)/2} S(w, x) dx.$$

In the second integral let  $x' = \theta-x-w$ ; the result, after omitting primes and combining the two integrals, is

$$I(w) = \int_{(\theta-w)/2}^{\infty} F(x)F(\theta-x-w)f(x+w)f(x-\theta) \{ [F(x+w-\theta)-F(x-\theta)]^F - [F(x+w)-F(x)]^F \} \left[ \frac{F(-x-w)f(x+w-\theta)}{f(x+w)F(\theta-x-w)} - \frac{F(x-\theta)f(x)}{f(x-\theta)F(x)} \right] dx.$$

Clearly, a sufficient condition for  $I(w)$  to be non-negative for  $w \geq 0$  is that the integrand above, call it  $T(x, w)$ , is non-negative for  $w \geq 0$  and  $x \geq (\theta-w)/2$ .

The expression in braces in  $T(x, w)$  is non-negative if and only if

$$[F(x+w-\theta)-F(x-\theta)] - [F(x+w)-F(x)] \geq 0,$$

for  $w \geq 0$  and  $x \geq (\theta-w)/2$ . This is clearly so since the left member of the

inequality is the difference of the probability contents of two intervals one of which is more central than the other.

By the corollary to Lemma 1 of Appendix I, the term in square brackets is non-negative for  $x \geq (\theta-w)/2$  and  $w \geq 0$ . Therefore  $T(x, w) \geq 0$ .

Theorem 6:

If N holds and  $\theta \neq 0$ , then  $P(0^r, 0, 1, 1, 0, 0^r) > P(0^r, 1, 0, 0, 1, 0^r)$  or, equivalently,  $P(1^r, 1', 0, 0, 1', 1^r) > P(0^r, 1', 0, 0, 1', 0^r)$ .

Proof:

Proceeding as was outlined above, one obtains, as a sufficient condition for the inequality  $P(1^r, 1', 0, 0, 1', 1^r) \geq P(0^r, 1', 0, 0, 1', 0^r)$ , the inequality

$$T(x, w) = \frac{(2r+2)!}{2(r!)^2} F(x-\theta)f(x+w-\theta)f(x)f(x+w)[G^2(x; w) - G^2(x-\theta; w)]\{[F(x-\theta)F(\theta-x-w)]^r - [F(x)F(-x-w)]^r\} \geq 0,$$

for  $\theta \geq 0$ ,  $w \geq 0$ , and  $x \geq (\theta-w)/2$ , where

$$(3.6) \quad G(x; w) = \frac{1}{\sqrt{2\pi}} \frac{F(x+w) - F(x)}{f\left(\frac{x+w}{\sqrt{2}}\right) f\left(\frac{x}{\sqrt{2}}\right)}.$$

By the corollary to Lemma 2 of Appendix I, with  $r = w/2$ ,  $y = x-r$ , the term in square brackets is non-negative for  $\theta \geq 0$ ,  $w \geq 0$ , and  $x \geq (\theta-w)/2$ .

Therefore  $T(x; w)$  is non-negative provided the term in braces is non-negative. This term is non-negative if and only if

$$[F(x-\theta)F(\theta-x-w) - F(x)F(-x-w)] \geq 0, \quad \text{for } x \geq (\theta-w)/2.$$

This inequality is proved in the corollary to Lemma 3 of Section 5.

Theorem 7:

If N holds and  $\theta \geq 0$ , then  $P(0, 1, 1, 0, z) \geq P(1, 0, 0, 1, z)$  for any  $z$  or,

equivalently,  $P(z, 1', 0, 0, 1') \geq P(z, 0', 1, 1, 0')$ .

Proof:

Proceeding as was outlined above, one obtains as a sufficient condition for the inequality  $P(z, 0, 1, 1, 0) \geq P(z, 1, 0, 0, 1)$ , the inequality

$$T(x, w) = [H(x) - H(\theta - w - x)] \{G^2(x; w) - G^2(x - \theta; w)\} f(x) f(x+w) f(x-\theta) f(x+w-\theta) \geq 0,$$

for  $w \geq 0$  and  $x \geq (\theta - w)/2$ , where  $G(x; w)$  is defined by (3.6) and

$$H(x) = \frac{(m+2)!(n+2)!}{2} \int_{-\infty < t_1 \leq \dots \leq t_{m+n} < x} \prod_{i=1}^{m+n} f(t_i - \theta z_i) dt_i,$$

$m$  and  $n$  being the number of zeros and ones in  $z$ .

It is shown by the Corollary to Lemma 2 of Appendix I that the term in braces in  $T(x; w)$  is non-negative for  $w \geq 0$  and  $x \geq (\theta - w)/2$ .

Clearly,  $H(x)$  is everywhere non-decreasing. Since  $x \geq (\theta - w)/2$  implies  $x \geq \theta - w - x$ , we have

$$H(x) \geq H(\theta - w - x),$$

for  $w \geq 0$ ,  $x \geq (\theta - w)/2$ . Thus, the term in square brackets is non-negative, and, therefore, so is  $T(x, w)$ .

4. Examples and Conjectures.

The following diagrams illustrate the theorems of Section 3. The symbol  $z \xrightarrow{abc} z'$  means  $P(z) \geq P(z')$  for  $\theta \geq 0$  (under ST, STU, or N) under conditions abc. C stands for Conjecture. The table accompanying some of the diagrams is extracted from an unpublished table of probabilities of rank orders under N computed by Jerome Klotz (1962). Note: MLR implies a simple ordering of the  $P(z)$  for  $n=1$ . Hence the first interesting case is  $m=n=2$ . All diagrams derived

are distributive lattices but the conjectured diagram for  $m=4$  and  $n=2$  is not distributive; in particular it does not satisfy the Jordan-Dedekind chain condition, i.e., not all chains from an arbitrary fixed  $z$  to (say) the least probable rank order are of the same length.

The notation, crossover  $\left\{ \begin{matrix} z \\ z' \end{matrix} \right.$ , denotes the fact that there exist two values of  $\theta$ ,  $\theta_1 > \theta_2 \geq 0$ , such that  $P(z|\theta_1) > P(z'|\theta_1)$  but  $P(z|\theta_2) < P(z'|\theta_2)$ .

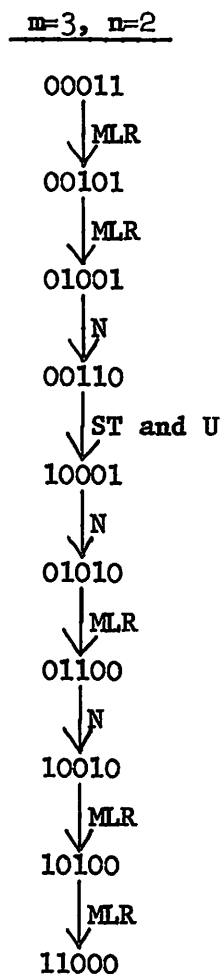
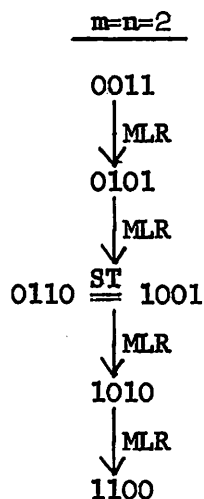

m=4, n=2

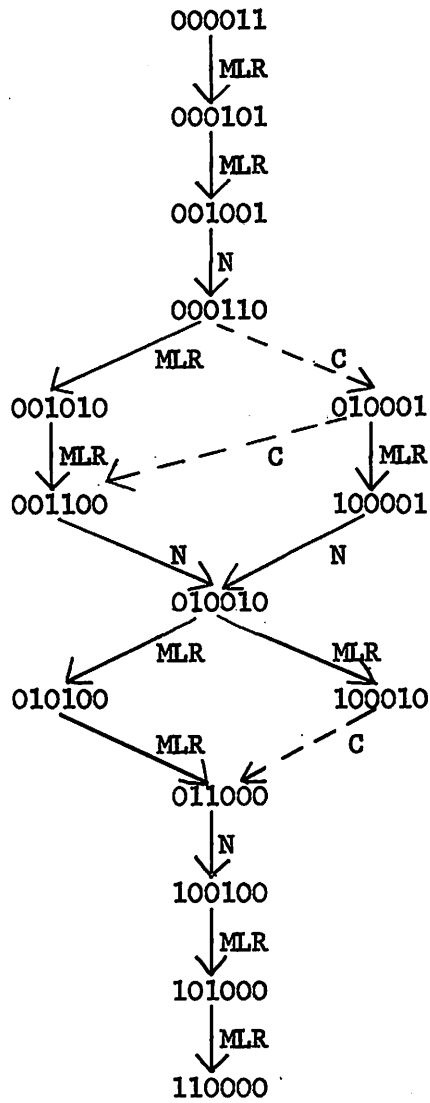

Ordering from Klotz Table

- 000011
- 000101
- 001001
- 000110
- 010001
- 001010
- 100001
- 001100
- 010010
- 010100
- 100010
- 011000
- 100100
- 101000
- 110000

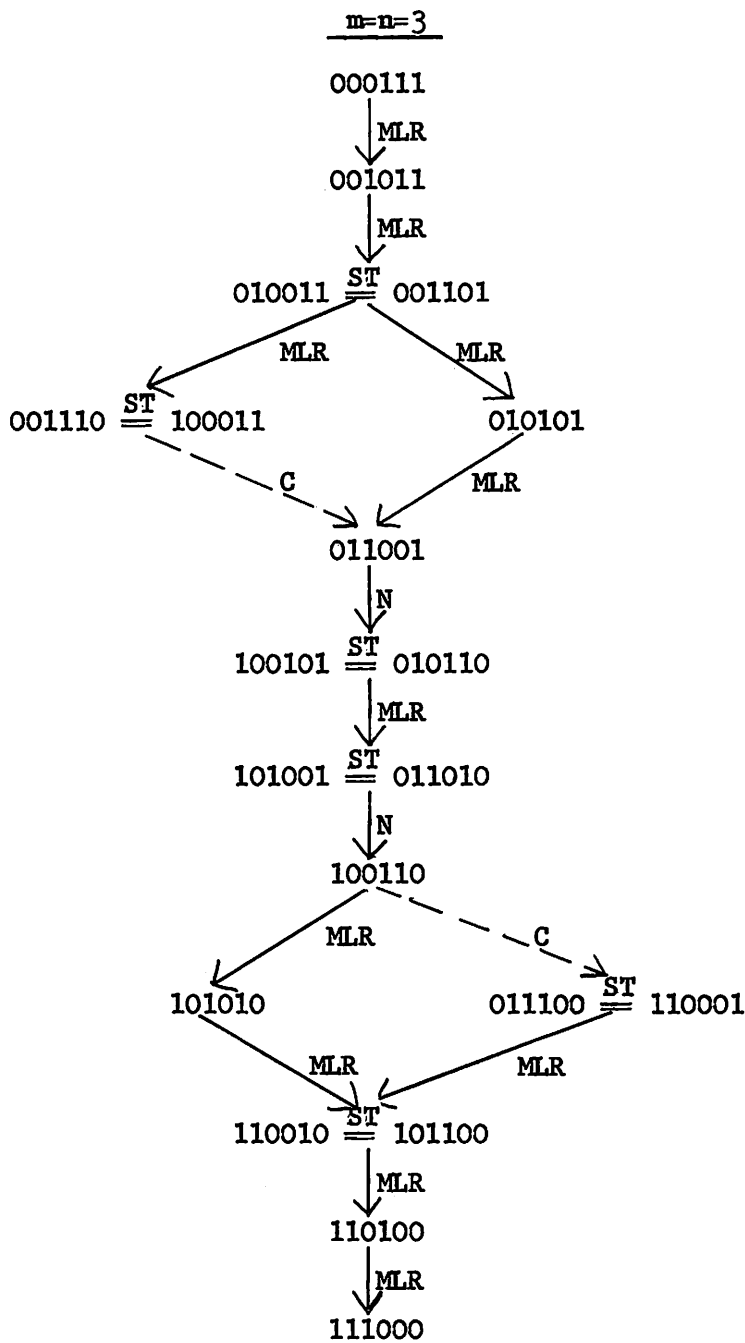

Ordering from Klotz Table

000111  
 001011  
 001101 = 010011  
 010101  
 100011 = 001110 } \*  
 011001  
 100101 = 010110  
 101001 = 011010  
 100110  
 110001 = 011100  
 101010  
 110010 = 101100  
 1101000  
 111000

\* crossover





Ordering from Klotz Table

m=4, n=3

|         |         |
|---------|---------|
| 0000111 | 0101010 |
| 0001011 | 1000110 |
| 0010011 | 1010001 |
| 0001101 | 0110010 |
| 0100011 | 0101100 |
| 0010101 | 1001010 |
| 0001110 | 1100001 |
| 0011001 | 0110100 |
| 0100101 | 1010010 |
| 1000011 | 1001100 |
| 0010110 | 0111000 |
| 0101001 | 1100010 |
| 0011010 | 1010100 |
| 1000101 | 1011000 |
| 0100110 | 1100100 |
| 0110001 | 1101000 |
| 0011100 | 1110000 |
| 1001001 |         |

\* crossover

For fixed  $m$  and  $n$  we define  $N(z)$  and  $N'(z)$  to be the number of rank orders less probable and more probable than  $z$ , respectively. The ideal situation for constructing tests of hypothesis is to have  $N(z)+N'(z) = \binom{m+n}{n}-1$ , i.e., the rank orders form a chain. The following table gives  $N(z)$ ,  $N'(z)$  and  $N(z)+N'(z)$  for  $m=4$ ,  $n=3$  for the ordering implied by Theorem 3 alone and for the ordering implied by Theorems 1 through 7. Note that the second ordering is an improvement over the first in the sense that  $N(z)+N'(z)$  for the second ordering is not smaller than that for the first. In particular there is considerable improvement in  $z = (1,0,0,0,0,1,1)$ ,  $(0,0,1,0,1,1,0)$ ,  $(0,1,1,0,0,0,1)$  and  $(0,0,1,1,1,0,0)$ .

| z       | MLR  |       |            | MLR or STU or N |       |            |
|---------|------|-------|------------|-----------------|-------|------------|
|         | N(z) | N'(z) | N(z)+N'(z) | N(z)            | N'(z) | N(z)+N'(z) |
| 0000111 | 34   | 0     | 34         | 34              | 0     | 34         |
| 0001011 | 33   | 1     | 34         | 33              | 1     | 34         |
| 0010011 | 30   | 2     | 32         | 30              | 2     | 32         |
| 0001101 | 29   | 2     | 31         | 29              | 2     | 31         |
| 0100011 | 24   | 3     | 27         | 25              | 3     | 28         |
| 0010101 | 27   | 4     | 31         | 28              | 4     | 32         |
| 0001110 | 19   | 3     | 22         | 22              | 3     | 25         |
| 0011001 | 21   | 5     | 26         | 24              | 5     | 29         |
| 0100101 | 22   | 6     | 28         | 22              | 6     | 28         |
| 1000011 | 14   | 4     | 18         | 19              | 5     | 24         |
| 0010110 | 18   | 6     | 24         | 21              | 7     | 28         |
| 0101001 | 20   | 8     | 28         | 20              | 8     | 28         |
| 0011010 | 15   | 8     | 23         | 17              | 8     | 25         |
| 1000101 | 13   | 8     | 21         | 16              | 8     | 24         |
| 0100110 | 15   | 9     | 24         | 15              | 11    | 26         |
| 0110001 | 12   | 9     | 21         | 16              | 9     | 25         |
| 0011100 | 9    | 9     | 18         | 11              | 11    | 22         |
| 1001001 | 11   | 11    | 22         | 12              | 12    | 24         |
| 0101010 | 13   | 13    | 26         | 13              | 13    | 26         |

To complete the table note that  $N(z^t) = N'(z)$ .

Appendix I.

Properties of Some Functions Related to the Normal Density Function

In the following  $f(\cdot)$  and  $F(\cdot)$  denote the standard normal density and distribution function, respectively.

Lemma 1:

If  $\theta$  is a positive constant, then  $G(x) = \frac{F(x-\theta)f(x)}{F(x)f(x-\theta)}$  is non-increasing for all  $x$ .

Proof:

A sufficient condition for the monotonicity of  $G(x)$  is that its first derivative is non-positive for all  $x$ , or, equivalently, that

$$G_1(x) = \theta F(x)F(x-\theta) + F(x-\theta)f(x) - F(x)f(x-\theta) \geq 0,$$

for all  $x$ .

Since  $G_1(-\infty) = 0$ , a sufficient condition for  $G_1(x) \geq 0$  is that  $G_1(x)$  is everywhere non-decreasing, which is so provided the first derivative of  $G_1(x)$  is non-negative.

Now,

$$\frac{d}{dx} G_1(x) = f(x)f(x-\theta) \left[ \frac{x f(x)}{f(x)} - \frac{(x-\theta) f(x-\theta)}{f(x-\theta)} \right].$$

Let  $G_2(x) = \frac{x f(x)}{f(x)}$ . Clearly, the term in square brackets is non-negative (hence  $\frac{d}{dx} G_1(x) \geq 0$ ) if  $G_2(x)$  is non-decreasing for all  $x$ , that is, if

$$f^{-1}(x) [x f(x) + F(x)(x^2 + 1)] \geq 0.$$

This is clearly so for  $x \geq 0$ . To see that it follows for  $x < 0$ , let  $G_3(x) = [x f(x) + F(x)(x^2 + 1)]$ . Since  $G_3(-\infty) = 0$  we need, as was noted above, show only that  $G_3(x)$  is non-decreasing for all  $x$ , or that

$$\frac{d}{dx} G_3(x) = 2[x f(x) + F(x)] \geq 0, \text{ which follows at once from the Feller-Laplace}$$

inequality:

$$F(x) \leq \frac{F(x)}{-x} \quad \text{for } x < 0.$$

Corollary:

If  $w$  and  $\theta$  are non-negative constants, then  $G(\theta - x - w) \geq G(x)$  for  $x \geq (\theta - w)/2$ .

Proof:

The conclusion follows at once from the fact that  $\theta - x - w \leq x$  whenever  $x \geq (\theta - w)/2$ .

Lemma 2:

If  $r$  is a positive constant, then  $H(y, r) = \frac{F(y+r)-F(y-r)}{f(\frac{y+r}{\sqrt{2}})f(\frac{y-r}{\sqrt{2}})}$  is

non-decreasing for  $y \geq 0$ .

Proof:

A sufficient condition for  $H(y, r)$  to be non-decreasing for  $y \geq 0$  is that its first derivative is non-negative, or, equivalently, that

$$H_1(y, r) = -f(y+r)-f(y-r)+y[F(y+r)-F(y-r)] \geq 0.$$

Since  $H_1(y, 0) = 0$  it is sufficient to show that  $H_1(y, r)$  is increasing in  $r$  for  $r \geq 0$  and fixed  $y \geq 0$ , or that

$$\frac{d}{dr} H_1(y, r) = r[f(y-r)-f(y+r)] \geq 0,$$

for  $y \geq 0$  and  $r \geq 0$ , which is clearly so.

Corollary:

Let  $\theta$  be a positive constant, then  $[H^2(y; r) - H^2(y-\theta; r)] \geq 0$  for all  $y \geq \theta/2$  and  $r \geq 0$ .

Proof:

It is evident that  $H(y; r)$  is symmetric about  $y=0$  (for fixed  $r \geq 0$ ), therefore  $H(y-\theta; r)$  is symmetric about  $\theta$ . In the interval  $[\theta/2, \theta]$ ,  $H(y-\theta; r)$  is decreasing while  $H(y; r)$  is increasing. Since the two are equal at  $y = \theta/2$ , clearly,  $H(y-\theta; r)$  is less than or equal to  $H(y; r)$  in this interval. Since  $H(y-\theta; r)$  is increasing to the right of this point and,  $y \geq y-\theta$ , one has  $H(y; r) \geq H(y-\theta; r)$ . Since  $H(\cdot)$  is non-negative, the result follows at once.

Lemma 3:

Let  $r$  be a positive constant, then  $F(y-r)F(-y-r)$  is non-increasing in  $y$  for  $y \geq 0$ .

Proof:

It is enough to show that the first derivative is non-positive, or, equivalently, that

$$\frac{f(y+r)}{F(y+r)} \leq \frac{f(r-y)}{F(r-y)},$$

for  $r \leq 0$ ,  $y \geq 0$ .

Since equality holds for  $y=0$  it is enough to show that  $\frac{f(t)}{F(t)}$  is non-increasing for all  $t$ , or that  $-tF(t)-f(t) \leq 0$ , for all  $t$ . If  $t \geq 0$  this is clear, if  $t < 0$  apply the Feller-Laplace inequality

$$F(t) \leq \frac{f(t)}{-t}.$$

Corollary:

If  $\theta$  and  $w$  are non-negative constants, then

$$F(x-\theta)F(\theta-x-w)-F(x)F(-x-w) \geq 0$$

for  $x \geq (\theta-w)/2$ .

Proof:

Let  $H(y; r) = -F(y-r)F(-y-r)$ , using this notation we are to show that

$$H(y; r) - H(y-\theta; r) \geq 0$$

for  $y \geq \theta/2$  and  $r \geq 0$  where  $H(y; r)$  is non-decreasing for  $y \geq 0$  and symmetric about  $y=0$ . This is proved as in the corollary to Lemma 2.

Appendix II.

Selected Numerical Results

The following tables give for several  $z$ 's, values of  $P(z)$  for different values of  $\theta$  under condition N. These tables were extracted from an unpublished

table of Klotz. Attention is directed towards  $z = (1,0,0,0,0,1,0,1)$  and  $z' = (0,0,1,0,1,0,1,0)$ . This was the first example of a pair of rank orders with common  $m$  and  $n$  values for which we have found the function  $P(z|\theta) - P(z'|\theta)$  to change sign on the positive  $\theta$  axis. The second example of such a "crossover"\* on the positive  $\theta$  axis that we found was with the vectors  $z = (0,1,0,1,0,1)$  and  $z' = (0,0,1,1,1,0)$  [or its equivalent by ST,  $z'' = (1,0,0,0,1,1)$ ], where  $m=n=3$ . An exhaustive search has not been made of the Klotz tables.

\*crossover defined on page 12.

$P(z)$  for selected values of  $\theta$  under condition N when  $m=3$  and  $n=2$  (from Klotz)

| $z \backslash \theta$ | .25    | .50    | 1.0    | 1.5    | 2.0    | 3.0               | 4.0                 | 5.0                 | 6.0                |
|-----------------------|--------|--------|--------|--------|--------|-------------------|---------------------|---------------------|--------------------|
| 00011                 | .14772 | .20814 | .36243 | .54014 | .70717 | .92051            | .98746              | .99883              | .99993             |
| 00101                 | .12978 | .15869 | .19948 | .20069 | .16348 | .06050            | .01115              | .00112              | .0 <sub>4</sub> 6  |
| 01001                 | .11445 | .12292 | .11764 | .08837 | .05260 | .00968            | .00080              | .0 <sub>4</sub> 3   | .0 <sub>6</sub> 64 |
| 00110                 | .10975 | .11333 | .10088 | .07097 | .03976 | .00655            | .00049              | .0 <sub>4</sub> 2   | .0 <sub>6</sub> 34 |
| 10001                 | .09706 | .08874 | .06209 | .03439 | .01517 | .00154            | .0 <sub>4</sub> 7   | .0 <sub>5</sub> 153 | .0 <sub>7</sub> 1  |
| 01010                 | .09669 | .08741 | .05838 | .02982 | .01166 | .00081            | .0 <sub>4</sub> 2   | .0 <sub>6</sub> 17  | 0                  |
| 01100                 | .08568 | .06899 | .03710 | .01552 | .00505 | .00025            | .0 <sub>5</sub> 463 | .0 <sub>7</sub> 3   | 0                  |
| 10010                 | .08193 | .06290 | .03041 | .01125 | .00317 | .00011            | .0 <sub>5</sub> 125 | 0                   | 0                  |
| 10100                 | .07253 | .04946 | .01905 | .00567 | .00130 | .0 <sub>4</sub> 3 | .0 <sub>6</sub> 23  | 0                   | 0                  |
| 11000                 | .06443 | .03942 | .01255 | .00318 | .00064 | .0 <sub>4</sub> 1 | .0 <sub>7</sub> 7   | 0                   | 0                  |

Subscripts on the first zero after the decimal indicate the number of zeros to be entered; for example, .0<sub>4</sub>6 stands for .00006.

P(z) for selected values of  $\theta$  under condition N when  $m=4$  and  $n=2$  (from Klotz)

| $z \backslash \theta$ | .25    | .50    | 1.0    | 1.5    | 2.0    | 3.0                | 4.0                 | 5.0                 | 6.0                 |
|-----------------------|--------|--------|--------|--------|--------|--------------------|---------------------|---------------------|---------------------|
| 000011                | .10454 | .15548 | .29662 | .47430 | .65377 | .90079             | .98380              | .99847              | .999914             |
| 000101                | .09313 | .12192 | .17290 | .19240 | .17020 | .07084             | .01398              | .00145              | .0 <sub>4</sub> 85  |
| 001001                | .08400 | .09871 | .11104 | .09580 | .06412 | .01411             | .00132              | .0 <sub>4</sub> 57  | .0 <sub>5</sub> 121 |
| 000110                | .07955 | .08871 | .09032 | .07094 | .04340 | .00804             | .00064              | .0 <sub>4</sub> 24  | .0 <sub>6</sub> 46  |
| 010001                | .07521 | .07903 | .07080 | .04837 | .02547 | .00341             | .00019              | .0 <sub>5</sub> 47  | 0                   |
| 001010                | .07170 | .07158 | .05712 | .03397 | .01510 | .00127             | .0 <sub>4</sub> 35* | .0 <sub>6</sub> 32* | 0                   |
| 100001                | .06450 | .05843 | .03941 | .02055 | .00835 | .00068             | .0 <sub>4</sub> 23* | .0 <sub>6</sub> 37* | 0                   |
| 001100                | .06433 | .05781 | .03771 | .01853 | .00688 | .00041             | .0 <sub>5</sub> 8   | .0 <sub>7</sub> 6   | 0                   |
| 010010                | .06415 | .05717 | .03607 | .01674 | .00572 | .00027             | .0 <sub>5</sub> 4   | .0 <sub>7</sub> 1   | 0                   |
| 010100                | .05753 | .04606 | .02357 | .00892 | .00250 | .0 <sub>4</sub> 79 | .0 <sub>6</sub> 75  | 0                   | 0                   |
| 100010                | .05500 | .04219 | .01992 | .00698 | .00181 | .0 <sub>4</sub> 48 | .0 <sub>6</sub> 38  | 0                   | 0                   |
| 011000                | .05317 | .03810 | .01647 | .00537 | .00131 | .0 <sub>4</sub> 33 | .0 <sub>6</sub> 26  | 0                   | 0                   |
| 100100                | .04929 | .03392 | .01291 | .00366 | .00077 | .0 <sub>4</sub> 13 | .0 <sub>7</sub> 7   | 0                   | 0                   |
| 101000                | .04467 | .02798 | .00893 | .00215 | .00039 | .0 <sub>5</sub> 53 | .0 <sub>7</sub> 1   | 0                   | 0                   |
| 110000                | .04022 | .02290 | .00620 | .00130 | .00021 | .0 <sub>5</sub> 23 | .0 <sub>7</sub> 1   | 0                   | 0                   |

Subscripts on the first zero after the decimal indicate the number of zeros to be entered; for example, .0<sub>4</sub>85 stands for .000085.

\*This appears to be another crossover but it is not clear that the eighth decimal should be trusted in this calculation.

P(z) for selected values of  $\theta$  under condition N when  $m=n=3$  (from Klotz)

| z \ $\theta$ | .25       | .50    | 1.0    | 1.5    | 2.0                | 3.0                  | 4.0                  | 5.0                | 6.0                |
|--------------|-----------|--------|--------|--------|--------------------|----------------------|----------------------|--------------------|--------------------|
| 000111       | .08222    | .12748 | .26025 | .43721 | .62357             | .88989               | .98186               | .99827             | .99990             |
| 001011       | .07392    | .10181 | .15726 | .18692 | .17369             | .07673               | .01554               | .00162             | .00010             |
| 001101       | .06603841 | .08081 | .09679 | .08695 | .05941             | .01301               | .00116               | .0 <sub>4</sub> 5  | .0 <sub>6</sub> 97 |
| 010011       | same as   | 001101 |        |        |                    |                      |                      |                    |                    |
| 010101       | .05896    | .06396 | .05878 | .03906 | .01889*            | .00176*              | .0 <sub>4</sub> 5    | .0 <sub>6</sub> 48 | 0                  |
| 001110       | .05654021 | .05935 | .05249 | .03492 | .01768*            | .00212*              | .00010               | .0 <sub>5</sub> 23 | .0 <sub>7</sub> 2  |
| 100011       | same as   | 001110 |        |        |                    |                      |                      |                    |                    |
| 011001       | .05335    | .05244 | .03974 | .02190 | .00884             | .00059               | .0 <sub>4</sub> 1255 | .0 <sub>7</sub> 9  | 0                  |
| 010110       | .05045053 | .04686 | .03156 | .01530 | .00535             | .00025               | .0 <sub>5</sub> 334  | .0 <sub>7</sub> 1  | 0                  |
| 100101       | same as   | 010110 |        |        |                    |                      |                      |                    |                    |
| 011010       | .04561    | .03830 | .02108 | .00835 | .00238             | .0 <sub>4</sub> 7425 | .0 <sub>6</sub> 66   | 0                  | 0                  |
| 101001       | same as   | 011010 |        |        |                    |                      |                      |                    |                    |
| 100110       | .04315    | .03427 | .01682 | .00589 | .00147             | .0 <sub>4</sub> 3305 | .0 <sub>6</sub> 19** | 0                  | 0                  |
| 011100       | .04101    | .03118 | .01433 | .00485 | .00120             | .0 <sub>4</sub> 3    | .0 <sub>6</sub> 22** | 0                  | 0                  |
| 110001       | same as   | 011100 |        |        |                    |                      |                      |                    |                    |
| 101010       | .03898    | .02792 | .01109 | .00312 | .00062             | .0 <sub>5</sub> 842  | .0 <sub>7</sub> 2    | 0                  | 0                  |
| 101100       | .03503    | .02268 | .00748 | .00178 | .00030             | .0 <sub>5</sub> 317  | .0 <sub>7</sub> 1    | 0                  | 0                  |
| 110010       | same as   | 101100 |        |        |                    |                      |                      |                    |                    |
| 110100       | .03146    | .01839 | .00501 | .00100 | .00015             | .0 <sub>5</sub> 115  | 0                    | 0                  | 0                  |
| 111000       | .02859    | .01534 | .00361 | .00064 | .0 <sub>4</sub> 84 | .0 <sub>6</sub> 57   | 0                    | 0                  | 0                  |

Subscripts on the first zero after the decimal indicate the number of zeros to be entered; for example, .0<sub>4</sub>5 stands for .00005.

\* This appears to be a bona-fide crossover.

\*\* This crossover may have resulted from a computational error.



P(z) for selected values of  $\theta$  illustrating a "crossover" and  
"symmetrical displacements" (from Klotz)

| z \ $\theta$                               | .25    | .50    | 1.0       | 1.5    | 2.0    | 3.0                  | 4.0                 | 5.0               | 6.0 |
|--|--------|--------|-----------|--------|--------|----------------------|---------------------|-------------------|-----|
| <b>Example of a crossing over.</b>         |        |        |           |        |        |                      |                     |                   |     |
| 10000101                                   | .01911 | .01851 | .01285461 | .00601 | .00190 | .0 <sub>4</sub> 6    | .0 <sub>6</sub> 44  | 0                 | 0   |
| 00101010                                   | .01933 | .01878 | .01285266 | .00574 | .00168 | .0 <sub>4</sub> 4    | .0 <sub>6</sub> 19  | 0                 | 0   |
| <b>Effect of moving in from both ends.</b> |        |        |           |        |        |                      |                     |                   |     |
| 10000001                                   | .03442 | .03082 | .01984    | .00958 | .00351 | .00022               | .0 <sub>5</sub> 516 | .0 <sub>7</sub> 5 | 0   |
| 01000010                                   | .03419 | .03000 | .01778    | .00744 | .00220 | .0 <sub>4</sub> 6815 | .0 <sub>6</sub> 53  | 0                 | 0   |
| 00100100                                   | .03418 | .02997 | .01771    | .00737 | .00216 | .0 <sub>4</sub> 6541 | .0 <sub>6</sub> 49  | 0                 | 0   |
| 00011000                                   | .03426 | .03025 | .01841    | .00804 | .00253 | .0 <sub>4</sub> 9    | .0 <sub>6</sub> 96  | 0                 | 0   |

Subscripts on the first zero after the decimal indicate the number of  
zeros to be entered; for example .0<sub>4</sub>6 stands for .00006.

Appendix III.

Approximations to P(z| $\theta$ ) under N

Theorem 8:

If N holds, then, for all  $\theta$ ,

$$P(z) = \binom{m+n}{n}^{-1} e^{-n\theta^2/2} E \exp\left\{ \theta \sum_{i=1}^{m+n} z_i W_i \right\},$$

where  $w_1, \dots, w_{m+n}$  are the order statistics of a sample of size  $m+n$  drawn from a standard normal population.

Proof:

We note that in this case

$$f(t_i - z_i \theta) = e^{-z_i^2 \theta^2 / 2} e^{z_i t_i \theta} f(t_i).$$

Thus

$$\begin{aligned}
 P(z) &= m!n! \int_{-\infty}^{\infty} \dots \int_{-\infty}^{\infty} \prod_{i=1}^{m+n} f(t_i - z_i \theta) dt_i \\
 &= \binom{m+n}{n}^{-1} e^{-n\theta^2/2} (m+n)! \int_{-\infty}^{\infty} \dots \int_{-\infty}^{\infty} \exp\left\{\theta \sum_{i=1}^{m+n} z_i t_i\right\} \prod_{i=1}^{m+n} f(t_i) dt_i.
 \end{aligned}$$

### Remarks

The first terms in the Maclaurin expansion of  $P(z|\theta)$  give approximations to  $P(z; \theta)$  for small  $\theta$ . For example

$$P(z|\theta) \doteq \binom{m+n}{n}^{-1} \left(1 + \theta \sum_{i=1}^{m+n} z_i EW_i\right).$$

Tables of the approximation got by including the next ( $\theta^2$ ) term in the Maclaurin expansion of  $P(z|\theta)$  are in preparation.

An interesting asymptotic result is given by Hodges and Lehmann (1962). This should give approximations to  $P(z|\theta)$  for large  $\theta$ ; this point has not been investigated, however.

### Appendix IV.

#### Some Nonlinear Relationships Between Rank Order Probabilities

In Savage (1960)p. 520, linear relationships like the following have been obtained:

$$P(0,1,1) = [P(0,1,1,0) + P(0,1,0,1) + 2P(0,0,1,1)]/2.$$

A pair of non-linear relationships is obtained below. Note that no restriction is made of the densities  $f(\cdot)$  and  $g(\cdot)$ .

Theorem 9:

$$A: P(0,1,1,0) = 2P(0,1,1) - 2P^2(0,1)$$

$$B: P(0,1,0,1) = 2P^2(0,1) - 2P(0,0,1,1) .$$

Proof:

We note first that

$$\begin{aligned} P^2(0,1) &= \left[ \int_{-\infty}^{\infty} F(x)g(x)dx \right]^2 \\ &= \int_{-\infty}^{\infty} \int_{-\infty}^{\infty} F(x)g(x)F(y)g(y)dxdy \\ &= 2 \int_{-\infty}^{\infty} \int_x^{\infty} F(x)F(y)g(x)g(y)dydx . \end{aligned}$$

Then to prove A, one has

$$\begin{aligned} P(0,1,1,0) &= 4 \int_{-\infty}^{\infty} \int_x^{\infty} F(x)[1-F(y)]g(x)g(y)dydx \\ &= 4 \int_{-\infty}^{\infty} \int_x^{\infty} F(x)g(x)g(y)dydx - 2P^2(0,1) \\ &= 2P(0,1,1) - 2P^2(0,1) . \end{aligned}$$

And to prove B, one has

$$\begin{aligned} P(0,1,0,1) &= 4 \int_{-\infty}^{\infty} \int_x^{\infty} F(x)[F(y)-F(x)]g(x)g(y)dydx \\ &= 2P^2(0,1) - 4 \int_{-\infty}^{\infty} \int_x^{\infty} F^2(x)g(x)g(y)dydx = 2P^2(0,1) - 2P(0,0,1,1) . \end{aligned}$$

Corollary 1:

$$A': P(1,0,0,1) = 2P(1,0,0) - 2P^2(1,0)$$

$$B': P(1,0,1,0) = 2P^2(1,0) - 2P(1,1,0,0)$$

Proof:

Simply interchange F and G (f and g) in the proofs of A and B.

Corollary 2:

$$P(0,0,1,1) + P(1,1,0,0) = 2[P(0,1,1) + P(1,0,0)] - 1 .$$

Proof:

The set of all possible rank orders for  $m=n=2$  is an exhaustive set of mutually exclusive events. Therefore

$$P(0,0,1,1) + P(1,1,0,0) + P(0,1,0,1) + P(1,0,1,0) + P(1,0,0,1) + P(0,1,1,0) = 1 .$$

Substituting the right members of A, B, A' and B' for  $P(0,1,1,0)$ ,  $P(0,1,0,1)$ ,  $P(1,0,0,1)$  and  $P(1,0,1,0)$ , we obtain

$$P(0,0,1,1) + P(1,1,0,0) = 2[P(0,1,1) + P(1,0,0)] - 1 .$$

Note that probabilities for all of the rank orders with  $m=n=2$  can be evaluated in terms of the probabilities for smaller sample sizes and  $P(0,0,1,1)$  or  $P(1,1,0,0)$ . More generally, for  $n=2$  and arbitrary fixed  $m=M$  let

$$z = (\underbrace{0, \dots, 0}_{r_1}, 1, \underbrace{0, \dots, 0}_{r_2}, 1, \underbrace{0, \dots, 0}_{r_3}) ,$$

where  $r_1 + r_2 + r_3 = M$ . Then

$$P(z) = \frac{M! 2!}{r_1! r_2! r_3!} \int_{-\infty}^{\infty} \int_{-\infty}^{\infty} \dots \int_{-\infty}^{\infty} F^{r_1}(x) [F(y) - F(x)]^{r_2} [1 - F(y)]^{r_3} g(x) g(y) dx dy$$

$$= \frac{M! 2!}{r_1! r_2! r_3!} \sum_{\substack{1 \leq i_1 \leq r_2 \\ 1 \leq i_2 \leq r_3}} \binom{r_2}{i_1} \binom{r_3}{i_2} (-1)^{r_2 + r_3 - (i_1 + i_2)} \int_{-\infty}^{\infty} \dots \int_{-\infty}^{\infty} F^{r_1 + r_2 - i_1}(x) \cdot F^{r_3 + i_1 - i_2}(y) g(x) g(y) dx dy .$$

For  $a+b < M$ , the integral

$$\int_{-\infty < x \leq y < \infty} \cdot \cdot \cdot \int F^a(x) F^b(y) g(x) g(y) dx dy$$

can be expressed as a linear combination of probabilities of rank orders for  $m < M$  and  $n=1$  or  $2$ . Therefore if all rank order probabilities for  $m < M$  and  $n=1$  and  $2$  have been computed, the only new integrals required are of the form

$$A_i = \int_{-\infty < x \leq y < \infty} \cdot \cdot \cdot \int F^i(x) F^{M-i}(y) g(x) g(y) dx dy, \quad i=0, \dots, M.$$

Since

$$\begin{aligned} A_i + A_{M-i} &= \int_{-\infty < x \leq y < \infty} \cdot \cdot \cdot \int [F^i(x) F^{M-i}(y) + F^{M-i}(x) F^i(y)] g(x) g(y) dx dy \\ &= \int_{-\infty}^{\infty} \int_{-\infty}^{\infty} F^i(x) F^{M-i}(y) g(x) g(y) dx dy \\ &= \left[ \int_{-\infty}^{\infty} F^i(x) g(x) dx \right] \left[ \int_{-\infty}^{\infty} F^{M-i}(y) g(y) dy \right] \end{aligned}$$

one needs to compute only one of the pair  $(A_i, A_{M-i})$ .

For  $n > 2$  we must consider  $n$ -fold integrals of the form

$$A(i_1, \dots, i_n) = \int_{-\infty < x_1 \leq \dots \leq x_n < \infty} \cdot \cdot \cdot \int \prod_{j=1}^n F^{i_j}(x_j) g(x_j) dx_j,$$

as above only those integrals for which  $\sum_{j=1}^n i_j = M$  need be evaluated. Then if

any of the  $i_j=0$  the dimensionality of the integral is easily decreased.

Generally,

$$\sum A(i_1, \dots, i_n) = \prod_{j=1}^n P(\underbrace{0, \dots, 0}_{i_j}, 1)$$

where the summation is over all permutations of  $(1, 2, \dots, n)$ .

#### Acknowledgment

Mr. George Woodworth and Mr. Desu M. Mahammulu have prepared this manuscript from the rough notes of the authors. The final form of Theorem 4.i and the discovery of Theorem 4.ii were made by Mr. Woodworth. He also prepared the diagram for  $m=4, n=3$ .

#### References

- [1] Hodges, J. L. and Lehmann, E. L. (1962), "Probabilities of Rankings for Two widely Separated Normal Distributions," Studies in Mathematical Analysis and Related Topics, edited by Gilbary, Solomon, and others, Stanford University Press.
- [2] Klotz, Jerome (1962), private communication.
- [3] Savage, I. Richard (1956), Contributions to the theory of rank order statistics: the two sample case, Ann. Math. Statist., 24, 590-615.
- [4] Savage, I. Richard (1957), Contributions to the theory of rank order statistics: the "trend" case, Ann. Math. Statist., 28, 968-977.
- [5] Savage, I. Richard (1960), Contributions to the theory of rank order statistics: computation rules for probabilities of rank orders, Ann. Math. Statist. 31, 519-520.
- [6] Savage, I. Richard (1962), Contributions to the theory of rank order statistics: applications of lattice theory, University of Minnesota, Department of Statistics Technical Report No. 15.