

Copyright
by
Kyle Joseph Jerro
2016

The Dissertation Committee for Kyle Joseph Jerro
certifies that this is the approved version of the following dissertation:

The Syntax and Semantics of Applicative Morphology in Bantu

**APPROVED BY
SUPERVISING COMMITTEE:**

Supervisor: _____

John Beavers

Michael Diercks

Patience Epps

Scott Myers

Stephen Wechsler

The Syntax and Semantics of Applicative Morphology in Bantu

by

Kyle Joseph Jerro, B.A. ; M.A.

Dissertation

Presented to the Faculty of the Graduate School

of the University of Texas at Austin

in Partial Fulfillment

of the Requirements

for the Degree of

Doctor of Philosophy

The University of Texas at Austin

May 2016

For Shanta

Acknowledgements

First and foremost I want to thank my advisor, John Beavers; without his persistent investment, constructive criticism, and encouragement, this dissertation would never have been possible. The same level of gratitude extends to the other members of my committee: Mike, for helping me make sense of the data and for being an encouraging voice. Pattie, for her input on the historical and typological issues and her thoughtful questions throughout. Scott, for his shared enthusiasm in Africa and African languages; I've always valued our chats at the copier about our beloved trips to Africa. Finally, Steve, for being a role model and pioneer in work on the syntax-semantics interface and for originally introducing me to the topic of applicative morphology.

Thank you to several friends who have supported me throughout my graduate career: Jim and Anne, Derya, Tammi, Danny, Kris, Michelle, Ellie, Eliana, Niamh, Evan, Michael and, of course, Joel for his support and encouragement. This dissertation would have never happened without the constant encouragement from Dr. Blanco and Dr. Geer. Also thank you to my sisters, Mickey and Scout, and to my parents and the rest of my family. I love you all.

Thanks also to all my students over the years for letting me share my fascination with language, especially the students in my Field Methods in Linguistics class at Princeton in Spring 2016 for bearing with me during the home stretch of writing. Thanks also to Adele Goldberg and Christiane Fellbaum for their feedback on many of the ideas here and for helping me feel at home during my stay in Princeton.

Of the utmost importance, I extend my profoundest gratitude, veneration, and love to the people in Rwanda, Kenya, and Malawi who have helped me throughout this dissertation, taking me in as a guest in their homes and sharing their languages and cultures with me. Their warmth, generosity, and hospitality have impacted every aspect of my life —

academically and personally — for the better, and I am forever grateful for having had the honor of making such generous and caring friends. I would also like to acknowledge my sponsors. This material is based upon work supported by the National Science Foundation under Grant No. 1451566. I also received assistance from the Carlota Smith Foundation and the LDMT-MURI Project (thanks especially to Jason Baldrige for all his support over the years).

In Malawi, I would like to thank Abambo Alex and Amayi Grace, as well as Japhet, Thokozani, and Yankho, for taking me in during my time in Gowa. Without the logistical help and friendly guidance of Joe Lanning, my trip to Malawi would have been much less productive and enjoyable. Thanks especially to Geoff Mlongoti, Nafe Mlongoti, Theo Dolozi, and Mwalimu Mackwell as well as Besta, Reyfus Hampton, Namayenda, Mike, Innocent, and Happy George for their judgments of Chicheŵa as well as for showing me a great time during my stay in Malawi. *Zikomo kwambiri.*

I am grateful to Sikuku and Hellen for not only their hospitality during my first stay in Kenya, but also for their personal guidance, advice, and for buying me a Tusker when I needed a break. Michael Marlo's help in getting set up in Kenya was indispensable. I am grateful to Moses Egesa, Benson Sindani, Krispinas Wafula, Tetas Wekesa, Rogers Wanjala, Benson Masai, Matthews Wekesa, Wekesa Wafula, Joseph Barasa, Sikuku Barasa, Obadiah Wafula, Antony Makokha, Christine Watoka, and especially Hesborn Sumba Wandabwa, for invaluable input and discussion of Lubukusu. Thanks as well to the entire Sifuna family, especially Maurice and Alfred, for not only helping me find a place to live, but making me feel at home in Bungoma. *Nasimile and asante sana.*

No place has been more important to my life or my research than the Urukundo Children's Home in Rwanda, and I want to thank Mama Arlene as well as Julliete, Jean Marie, Olive, Betty, Francoise, Florida, Delphine, Chantal, Josephine, Vestine, Clarise, Rahab, Cecilia, Theresa, Benjamin, Libby, and Habimana for creating this beautiful home and letting

me be a part of it. *Urukundo* means “love” in Kinyarwanda, and the kids at Urukundo have given me the most profound gift of love since my first visit there several years ago; to Livine, Honorine, Jenett, Kavine, Diane, Claudine, Rebecca, Sarah, Kenilla, Aline, Benita, Nelly, Jason, Soso, Isiah, Kaboss, Johnny, David, Agide, Claude, Claude, Luki, Kenny, Cedric, Emmanuel, Jacob, Prince, Ives, Kevin, Abis, Bosco, Emmanuel, John Paul, Di-escor, Tresor, Anita, Anett, Lilliane, Alexander, Fabrice, Esperance, Giselle, Cecelia, Paci-fique, Serephine, Deborah, Esperance, Belise, Lucie, Solange, Divine, and Olivier, I love you all from the bottom of my heart. *Ndamukunda mwese*. Without Gilbert and Félicité Habarurema, this dissertation would never have been possible. For their help and patience while teaching me Kinyarwanda as well as their friendship, I am deeply grateful. *Murakoze cyane*.

Finally, thank you to Shanta, whose presence all these years has made my life indelibly more colorful and meaningful.

The Syntax and Semantics of Applicative Morphology in Bantu

by

Kyle Joseph Jerro, Ph.D.

The University of Texas at Austin, 2016

Supervisor: John Beavers

This dissertation concerns itself with the applicative morpheme, often analyzed as a valency-increasing morpheme which licenses an additional object to the argument structure of a verb. To date, applicativization has been analyzed as an operation that monotonically adds a new object to the argument structure, with little significant interaction with the verb to which the applicative attaches. However, there are two broad empirical issues with this view. First, there are instances in several languages where the applied variant of a particular verb licenses no additional object, contingent on the choice of verb. Second, the semantic role of the applied object is often conditioned by the meaning of the verb. In this dissertation I propose that applicativization serves fundamentally only to restrict the truth-conditional content of an internal argument of the verb, but that this constraint can be satisfied in various constrained ways on a verb class-by-verb class basis of which canonical object addition is just an option. I present evidence from locative applicatives in Kinyarwanda that the semantic role of the locative applied object, and whether it is even present, is conditioned by the meaning of the verb to which the applicative attaches. Furthermore, I show that the semantics of both verb class and the applicative are important in capturing instrumental applicative-causative syncretism and constraints on what thematic role the applied object of such an applicative will have contingent on the particular verb. Finally, I

revisit the question of object symmetry, where I argue that contra the dominant perspective in the literature, there is no universal correlation between a particular syntactic structure or thematic role and any particular symmetry pattern. Instead, I propose that symmetry facts follow on a language by language basis from a variety of factors, such as verb meaning, thematic role, cast of the relevant nouns, and information structure. This semantically-driven framework in which a *mélange* of other factors conspire to determine symmetry provides a more comprehensive empirical account of the syntactic and semantic nature of applicative morphology in Bantu.

Table of Contents

Chapter 1: Introduction	1
Chapter 2: Background	8
Section 1: Languages of the Study	8
1.1 Kinyarwanda	9
1.2 Chicheŵa	13
1.3 Lubukusu	16
Section 2: Lexical Semantics and Argument Realization	20
2.1 Empirical Basis	20
2.2 Thematic Roles	23
2.3 Event Structures	25
2.4 Lexical Entailments	30
2.5 Summary	32
Section 3: Elicitation Methodology	33
Chapter 3: The Locative Applicative and the Semantics of Verb Class	35
Section 1: Introduction	35
Section 2: Locatives and Locative Applicatives	37
2.1 Locative Applicatives	38
2.2 The Status of Locative Prefixes	43
2.3 Post-Verbal Locative Clitics	48
2.4 Interim Summary	49
Section 3: Verb Classes and Locative Applicatives	50
3.1 The Typology of Locative Applicatives in Kinyarwanda	53
Section 4: Analyzing the Kinyarwanda Locative Applicative	57
4.1 Applicativization as a Semantic Constraint	57
4.2 Possible Paradigms	58

4.3 Productivity and Lexicalization	60
4.4 The Framework of Analysis	63
4.5 The General Case	66
4.6 Motion Verbs	68
4.7 Manner of Motion Verbs	79
4.8 Modifying the Semantic Role of an Extant Argument	88
4.9 Summary	97
Section 5: Conclusion	98
Chapter 4: The Causative-Instrumental Syncretism	100
Section 1: Introduction	100
Section 2: The Morpheme <i>-ish</i>	103
Section 3: Applicative vs. Causative Structure	107
3.1 Event Structure and Two Types of Applicatives	107
3.2 Causative Structure	113
Section 4: Against Homophony	120
4.1 Semantic Vagueness	121
4.2 Causative and Applicative are Syntactically Identical	123
4.3 Diachronic Evidence	126
4.4 Further Evidence	127
4.5 Interim Summary	130
Section 5: Explaining the Syncretism	130
5.1 Theoretical Preliminaries	130
5.2 Caused Change-of-State Verbs	134
5.3 <i>-ish</i> and Intransitive Verbs	141
5.4 Implicit Instruments	145
Section 6: Conclusion	150

Chapter 5: The Syntax and Semantics of Object Symmetry	151
Section 1: Introduction	151
Section 2: The Syntax of Symmetry	153
2.1 Early Approaches to Symmetry	153
2.2 Thematic Role and Object Symmetry	157
2.3 Minimalist Approaches to Symmetry	163
2.4 The Semantics of High and Low Applicatives	168
Section 3: Variation Across Languages and Diagnostics	172
3.1 Benefactive Applicatives	174
3.2 Locative Applicatives	178
3.3 Instrumental Applicatives	182
3.4 Morphological Causatives	186
3.5 Results	190
3.6 On Oblique Marking and Resumptive Pronouns	192
3.7 Other Syntactic Tests for Object Relations	195
Section 4: The Effect of Verb Meaning on Symmetry	202
Section 5: Conclusion	215
Chapter 6: Conclusion	217
References	220

Chapter 1: Introduction

This dissertation investigates the relationship between lexical semantics and argument realization, looking specifically at the interaction of verbal meaning with two kinds of valency-increasing morphemes in Eastern African Bantu languages: the applicative and the causative. Generally, causatives and applicatives add a new subject and object, respectively, to the argument structure of a verb. The data in (1) from Kinyarwanda provides examples of a sentence with an applicative in (1b) and the morphological causative in (1c), in both cases derived from the base transitive verb *ku-mena* ‘break’ in (1a).¹

- (1) a. *Umw-ana y-a-menn-ye igi-kombe.*
1-child 1S-PST-break-PERF 7-cup
‘The child broke the cup.’
- b. *Umw-ana y-a-men-ey-e igi-kombe mama w-e.*
1-child 1S-PST-break-APPL-PERF 7-cup 1.mother 1-POSS
‘The child broke the cup for his/her mother.’
- c. *Umw-arimu y-a-men-esh-eje umw-ana igi-kombe.*
1-teacher 1S-PST-break-CAUS-PERF 1-child 7-cup
‘The teacher made the child break the cup.’

In (1a), the verb *ku-mena* ‘to break’ is syntactically transitive, with a subject and an object. In (1b), the presence of the applicative morpheme *-er* (realized here as *-ey*) licenses an additional object with the interpretation of being the beneficiary of the event; otherwise, the subject and object of the non-applied verb in (1a) are preserved. In (1c), the causative morpheme *-esh* licenses a new causer subject, demoting the previous subject to an object, while the underlying patient object is preserved.² Thus in cases in which either the applicative or the causative introduces an argument onto a transitive verb, the result is a derived ditransitive.

¹There are several allomorphs of the perfective morpheme, and it often affects the pronunciation of the stem. I give a description of the morphophonological nature of the morpheme in Chapter 2.

²In Kinyarwanda, the two objects can usually appear in either order for most speakers. See Chapter 5 for discussion of the order of objects in applied transitive sentences.

The traditional analysis of the applicative is that it adds a new object to the argument structure of the verb, and this object is furthermore assigned one of a specific set of broadly-defined thematic roles, such as *locative, beneficiary, instrument, etc.*³ Crucially, it has usually been assumed that regardless of the verb's meaning or its existing arguments, the additional object licensed by the applicative morpheme is added in a strictly monotonic fashion: the underlying argument structure of the verb and all of its lexical semantic content is otherwise preserved, albeit augmented with a wholly new object whose thematic role is determined entirely by the applicative in a consistent fashion across all base verbs. It has been noted in previous work that there are certain restrictions with respect to the transitivity of the base verb (e.g. Peterson 2007:60-63, Pylkkänen 2008:19-21), but the role of verb meaning has not been investigated much beyond transitivity (see also Machobane 1989 for discussion of the role of transitivity in Sesotho). In Bantu linguistics in particular the key focus of prior research has therefore mainly been the question of object symmetry, which investigates how the applied object (or the demoted causee) compares in its syntactic behavior to a thematic object of the verb (e.g. Gary & Keenan 1977, Kisseberth & Abasheikh 1977, Baker 1988, Bresnan & Moshi 1990, Alsina & Mchombo 1993, *inter alia*; see Chapter 5).

However, two broad empirical points problematize the traditional view of applicatives. One issue is that the range of thematic roles of applied objects is more diverse than acknowledged in the syntactic literature. Previous work has attended to the semantic role of the applied object primarily as a means of categorizing arguments in order to make generalizations about the syntactic structure of the sentence. Little has been said, however, about the various meanings that may be conveyed with each kind of applicative. For example, in (1b), the sentence actually has several possible interpretations. One is that the child broke the cup on her mother's behalf, while another is that the child broke the cup to her mother's

³In functionalist approaches, it is claimed that the applicative morpheme serves to place an argument in a more topical or discourse-salient position (Givón 1983, Rude 1986, Dixon & Aikhenvald 1997, Donohue 2001, Peterson 2007), though I set aside here, focusing instead on the contrast in meaning between applied and non-applied variants of a given verb.

dismay. It is also possible to get a possessive reading, where the child broke a cup that belonged to her mother. However, certain readings are ruled out for this verb. For example, it is not possible that the mother received the broken cup. Yet with other verbs in the language, such as *ku-jugunya* ‘to throw’, a recipient reading of the applied beneficiary object added by *-ir* is indeed possible, in addition to the various beneficiary readings discussed above. This is shown in (3), where the applied object of *ku-jugunya* ‘to throw’ can be a recipient or a (true) beneficiary (cp. the non-applied variant in (2) where there is no applied object).⁴

(2) *N-a-juguny-e* *umu-pira.*
 1SGS-PST-throw-PERF 3-ball
 ‘I threw the ball’

(3) *N-a-jugun-iy-e* *Mukamana umu-pira.*
 1SGS-PST-throw-APPL-PERF Mukamana 3-ball
 ‘I threw Mukamana the ball.’ OR ‘I threw the ball for Mukamana.’

The variation in the interpretation of the applicative touches on an additional point: the semantic role assigned to the applied object is often in part contingent upon the meaning of the verb, a fact that has gone almost completely unnoticed in previous work. For example, consider the following data from Kinyarwanda, where in (4b), the applied object of the verb *gu-teka* ‘to cook’ is the general location where the event took place, while in (5), the applied object of the verb *kw-ambuka* ‘to cross’ is the source of the motion event.

(4) a. *Mukamana y-a-tets-e.*
 Mukamana 1S-PST-cook-PERF
 ‘Mukamana cooked.’
 b. *Mukamana y-a-tek-ey-e* *mu gi-koni.*
 Mukamana 1S-PST-cook-APPL-PERF 18 7-kitchen
 ‘Mukamana cooked in the kitchen.’

⁴There is a literature on the typology of beneficiary meanings (e.g. Kittilä & Zúñiga 2010), but this has not been incorporated more broadly into work on applicative morphology in Bantu languages.

- (5) a. *Mukamana y-∅-ambuts-e (mu) n-yanja.*
 Mukamana 1S-PST-cross-PERF 18 9-ocean
 ‘Mukamana crossed the ocean.’
- b. *Mukamana y-∅-ambuk-iy-e (mu) n-yanja i Mombasa.*
 Mukamana 1S-PST-cross-APPL-PERF 18 9-ocean 23 Mombasa
 ‘Mukamana crossed the ocean from Mombasa.’

As I show in more detail below, for cases like those in (4) and (5), the semantic role of the applied locative depends upon the semantic class of the verb to which the applicative attaches (in this case, whether the verb is a motion verb of some type or not is crucial). This variation across verb classes is unexplainable on previous approaches which assume the semantic role of the applied object is transparently added without consideration of the meaning of the base verb.

The second issue with the traditional view is that the applicative does not always license a new argument; in some instances it instead restricts the interpretation of an object or other argument already licensed semantically or even syntactically by the verb. This has been noticed by various authors, such as Harford (1993), Marten & Kempson (2002), Marten (2003), Creissels (2004), Cann & Mabugu (2007) and Bond (2009), but it has not been incorporated into the theory of applicative morphology. For example, Marten (2003) notes that in Swahili the applicative sometimes indicates a pragmatically noteworthy or salient property of the base verbal object in lieu of adding a new argument, such as in (6b), where the specific kind of clothing is pragmatically highlighted by the applicative.

- (6) a. *Juma a-li-va-a kanzu*
 Juma 1S-PST-wear-FV kanzu
 ‘Juma was wearing a Kanzu.’
- b. *Juma a-li-val-i-a nguo rasmi.*
 Juma 1S-PST-wear-APPL-FV clothes official
 ‘Juma was dressed up in official/formal clothes.’

c. #*Juma a-li-val-i-a* *kanzu*.
Juma 1S-PST-wear-APPL-FV *kanzu*
Intended: ‘Juma was wearing a Kanzu.’ (Swahili, Marten 2003,9,(14))

In (6b), there is no additional object beyond what is present with the non-applied verb in (6a); the difference between the two is that in (6b) the object is associated with additional salient pragmatic information. The object in (6c) does not describe a pragmatically salient property of the dress, and this makes it incompatible with this use of the applicative.

In addition to applicatives, I also incorporate morphological causatives into the discussion, as many of the same points of variation arise in morphologically causativized sentences. Morphological causativization has been traditionally analyzed as an operation which adds a new subject to a base predicate, demoting the subject of the verb to an object or some other non-subject grammatical function. The morphological causative, then, parallels applicatives in that it attaches to a verb stem and derives a new argument structure. However, in many of the world’s languages (including Kinyarwanda) the morphological causative is syncretic with the applicative (Shibatani 2002, Tuggy 1988, Bostoen & Mundeke 2011, Hemmings 2013). The presence of a syncretism between the applicative and causative presents a puzzle for research on argument structure. Traditionally, the applicative is an operation which adds a new object, while the causative is an operation which adds a new subject, and thus the syncretism between the two is surprising. In this thesis I outline a semantically-driven analysis of the syncretic morpheme *-ish* in Kinyarwanda which can capture both of the putatively distinct uses of the morpheme as two outgrowths of a single functionality.

The central goal of this dissertation is thus to provide a frame of analysis for applicative and causative morphology that better captures the empirical variation found within and across languages for how the overall resulting verbal predicate is interpreted. Most centrally, I propose that to adequately analyze the nature of applicative morphology cross-linguistically, it is crucial to investigate the interaction of verb meaning with the semantics

of the valency-changing morpheme. Furthermore, while applicatives indeed add new lexical semantic content about some participant, it need not necessarily be a *new* participant. I propose instead an analysis of applicativization as a paradigmatic condition in which the applied variant of a verb encodes a monotonically stronger set of truth conditions than the non-applied variant. Verbs from distinct semantic classes interact differently with applicative morphology, satisfying the output condition in various constrained ways. In order to flesh out the interaction of verb meaning and applicative morphology, I focus on data from three Bantu languages: Chicheŵa (Malawi), Lubukusu (Kenya), and Kinyarwanda (Rwanda), with Kinyarwanda being the main focus of the dissertation.

The structure of the dissertation is as follows. I provide a descriptive overview of the three languages of focus in Chapter 2 as well as a summary of the relevant literature on the lexical semantics of argument realization. In Chapter 3, I flesh out the interaction between the locative applicative with verbs of motion, describing a rich pattern in Kinyarwanda where the interpretation of the applied object is crucially dependent on the motion semantics of the verb to which the applicative is attached. I present an analysis of applicativization as an output condition on the truth-conditional content of an argument of the applicativized verb in contrast with the non-applicativized version, and I exemplify three strategies in which this condition is satisfied.

I then turn to the causative-instrumental syncretism in Chapter 4. In Kinyarwanda the causative and instrumental applicative are both marked with the morpheme *-ish*, which historically arises from the causative morpheme in Proto-Bantu. I argue in that chapter that the two readings are outgrowths of the same operation of adding a new event to the causal chain of the verb, and the argument realization of the new causal participant derives from general constraints on lexical meaning and the idiosyncratic meaning of the verb to which the morpheme is attached that has as an outgrowth either an instrumental or causal reading, with some significant interactions with the meaning of the base verb.

Finally, I return to the question of how applied objects compare in grammatical function to the thematic objects of transitive verbs, arguing in Chapter 5 that the thematic type of applicative does not universally correlate with any specific syntactic structure, contra the mainstay of research on the syntax of applied objects. I instead show from previously published and newly collected comparative data that the object symmetry facts across languages vary greatly with different thematic roles. Furthermore, I show that within a language, diagnostics for objecthood are not consistent in their results, arguing that syntactic symmetry cannot be derived from a single point of variation. Instead, I propose that whether object symmetry or asymmetry arises in a particular language is contingent upon a variety of factors, including thematic role, inherent properties of the NPs, information structure, and the diagnostic under discussion. In keeping with the larger theme of the dissertation, I also show that there is tentative evidence that semantic verb class is an additional component in the determination of object symmetry.

I conclude the discussion in Chapter 6, pointing to future directions for the application of the framework developed in this dissertation.

Chapter 2: Background

In this chapter I provide the necessary background to set the stage for the discussion throughout the rest of the dissertation. In §1 I give a linguistic overview of the three languages that are at the center of this study. In §2 I outline some previous research on the interaction between the semantics of verb class and argument realization patterns in order to orient the theoretical discussion I present in the chapters that follow.

1 Languages of the Study

Before I begin the discussion of the argument structure and valency-changing morphology in Bantu, I first provide a general description of three Bantu languages that I primarily discuss in this study, namely Kinyarwanda, Lubukusu, and Chicheŵa, which are spoken in Rwanda, Kenya, and Malawi, respectively. As is typical of many Bantu languages, all three languages employ SVO word order in basic declarative clauses, and they have rich valency-changing and tense/aspect morphology.

One well-known feature of Bantu is its noun class marking, where each noun is marked with a specific class prefix. In Bantuist convention, odd class numbers indicate the singular, and even class numbers indicate the corresponding plural. For example, classes 1 and 2 indicate the singular and plural for nouns referring to humans. The verb agrees with the noun class of the subject noun, as shown in (1) from Kinyarwanda.

- (1) a. *Umu-gabo a-z-iruk-a* *ejo*.
1-man 1S-FUT-run-IMP tomorrow
'The man will run tomorrow.'
- b. *Aba-gabo ba-z-iruk-a* *ejo*.
2-man 2S-FUT-run-IMP tomorrow
'The men will run tomorrow.'

The subject differs in plurality between the (a) and (b) examples, and the class prefix on

the noun obligatorily triggers agreement on the verb. Following the subject marker, but preceding the verb root, is a tense morpheme. Bantu languages have rich tense-aspect systems (Nurse 2008), with some languages even having up to three distinctions for past and future tenses. Following the verb stem is an aspect suffix, almost always indicated by a vowel. In the Bantuist literature, this is often referred to as the “final vowel.” Most languages minimally distinguish between perfective and imperfective, though other languages may indicate subjunctive/indicative moods as well.

For each of the languages under discussion here, I give a brief description of certain crucial phonological and morphological features of the languages in order to aid in readability throughout the thesis, since some of the underlying morphological processes can be obscured on the surface by independent morphophonological processes. I provide also the consonant inventory of each language, and discuss relevant orthographical mismatches among languages that will be used in the data presented here. I do not give inventories of vowels, since all three languages have the same five phonemic vowels: /a e i o u/, with modulations for vowel length and tone that are not relevant here.¹

1.1 Kinyarwanda

Kinyarwanda (Guthrie classification: JD61) is spoken as the official language of Rwanda by roughly 12 million people. Another million also speak the language natively in parts of the Democratic Republic of Congo and Uganda. It is closely related to and mutually intelligible with Kirundi, the national language of Burundi, and Giha, spoken in Western Tanzania (Lewis et al. 2016).

Kinyarwanda has a rich consonant inventory, given in Table 1 (Kimenyi 1979). Kinyarwanda is notable for its many palatal consonants, which contrast with post-alveolar consonants. For example, consider the following minimal pair:

¹Phonetically, these vowels differ among the languages, but I leave a detailed description of the phonetics of vowels aside here. I point the reader to the cited works for the individual languages for further discussion.

- (2) *gu-ca* [gutʃa] ‘to cut/tear’
gu-cya [guca] ‘to be clean’

These two words differ in post-alveolar and palatal places of articulation. As is typical

	Bilabial	Labial	Alveolar	Post-alveolar	Palatal	Velar	Glottal
Plosive	p b		t d		c ɟ	k g	
Nasal	m		n		ɲ	ŋ	
Fricative	β	f v	s z	ʃ ʒ	ç		h
Affricate			ts	tʃ			
Glide					j	w	
Rhotic			r				

Table 1: Consonant Inventory in Kinyarwanda

of Bantu, Kinyarwanda also has an elaborate agreement system, where nouns are marked with one of sixteen semantically-categorized noun classes, which are given in Table 2 (Jerro 2013b, Jerro & Wechsler 2015). These classes indicate various features such as plurality

Class		Noun		SM		OM	
SG	PL	SG	PL	SG	PL	SG	PL
1	2	umu-	aba-	a-	ba-	mu-	ba-
3	4	umu-	imi-	u-	i-	wu-	yi-
5	6	i(ri)-	ama-	ri-	a-	ri-	ma-
7	8	iki-	ibi-	ki-	bi-	ki-	bi-
9	10	in-	in-	i-	zi-	yi-	zi-
11		uru-		ru-		ru-	
12	13	aka-	utu-	ka-	tu-	ka-	tu-
14		ubu-		bu-		bu-	
15		uku-		ku-		ku-	
16		aha-		ha-		ha-	
17		ku		ha-		ha-	
18		mu		ha-		ha-	
23		i		ha-		ha-	

Table 2: Noun classes in Kinyarwanda, (modified from Seymour 2016)

and animacy as well as conceptual categories like animals and abstract ideas. The table provides the corresponding singular and plurals of each of the classes (when relevant) as well as the corresponding subject agreement marker (SM) and object marker (OM).²

²Note that the classes 16, 17, 18, and 23 all share the same subject and object agreement morphology. This is because all of these classes are used for marking locative phrases, sharing the class 16 locative agreement morphology. See Chapter 3, §2.2 for discussion.

The Kinyarwanda perfective suffix (*-e*) has several allomorphs (*-eje*, *-ije*, *-eye*, *-iye*) and often causes palatalization of the final consonant of the stem. Most notably for the data presented through the dissertation, the consonant *r* [r] is palatalized to the glide [j] (orthographically *y*) when the perfective morpheme follows it. This is important to note because the applicative morpheme *-ir* immediately precedes any aspect morphology, and thus the concatenation of */-ir/* and */-e/* is pronounced [ije] (orthographically ‘*iyé*’).

Juxtaposed vowels result in vowel deletion. I leave the details aside here, but examples may often either have a selected vowel at the beginning of a word due to hiatus resolution between words or have a deleted past tense morpheme (which is underlyingly *a-*). In glosses, the initial vowel is deleted without marking. For cases where the tense morpheme is deleted, I indicate this deletion with the null morpheme (\emptyset).

Just like most of its sister languages, Kinyarwanda has several valency-changing morphemes which appear between the verb stem and the aspect suffix (Kimenyi 1980). These include the reciprocal (3a), benefactive applicative (3b), and the instrumental applicative/causative at the center of Chapter 4 in (3c).³

- (3) a. *Aba-gore ba-ra-reb-an-a.*
 2-woman 2S-PST-see-RECIP-IMP
 ‘The women are looking at each other.’
- b. *Karemera a-ra-tek-er-a umw-umbati umw-ana we.*
 Karemera 1S-PRES-cook-BEN-IMP 3-cassava 1-child 1.his
 ‘Karemera is cooking a cassava for his child.’
- c. *Karemera a-ra-kubit-ish-a uru-kuta in-koni.*
 Karemera 1-PRES-hit-ISH-IMP 10-wall 9-stick
 ‘Karemera is hitting the wall with a stick.’

The benefactive and instrumental/causative morphemes each have two allomorphs, with the vowel matching the height of the preceding vowel of the stem. When the vowel in the stem is mid (i.e. [o] or [e]), the allomorphs *-esh/-er* are used; otherwise, the allomorphs

³Here, I gloss the morpheme *-ish* as *-ISH* without committing to either the causative or instrumental applicative use — see the discussion in Chapter 4.

–*ish/–ir* are used (Kimenyi 1979). For applicative morphemes, the palatalization triggered by perfective morphology results in the /r/ being pronounced as a palatal glide [j], represented orthographically as “y.” For the duration of the paper, I will use the –*ish/–ir* forms as citation forms.

Object markers are optionally marked as a prefix before the stem, and they are in complementary distribution with a full object DP.⁴ The object prefix matches in class with the nominal to which it refers. For example, consider (4), which has an object marker that stands in for the full object.

- (4) *Umu-higi y-a-gi-tem-ey-e umw-ana.*
 1-hunter 1S-PST-7O-cut-APPL-PERF 1-child
 ‘The hunter cut it (e.g. the tree) for the child.’

In (4), the object marker *gi–* refers to an element from class 7, such as a tree (*igi-ti* ‘7-tree’). The phonological shape of the object marker is conditioned by the voicing of the consonant in the following syllable, and it must have the opposite voicing feature of that consonant. In (4), the object marker is the allomorph with the voiced palatal stop (*gi–* [ji]) because the consonant in the following syllable, namely [t], is voiceless. In a stem with a voiced consonant, such as *ku-mena* ‘to break’, the allomorph *ki–* is used:

- (5) *Umw-ana y-a-ki-men-ey-e mama w-e.*
 1-child 1S-PST-7O-break-APPL-PERF 1.mother 1-POSS
 ‘The child broke it (e.g. a cup) for his mother.’

Crucially, the voicing is contingent upon the voicing of the immediately following syllable. For example, rearranging the object markers changes the voicing of the class 7 object marker.⁵

⁴There is considerable variation in Bantu languages in whether the object marker is a referential object pronoun or whether it is an object agreement marker (see, among others, Bresnan & Mchombo 1987, von Heusinger 2002, Buell 2006, Henderson 2006, Adams 2010, Diercks & Sikuku 2011, Baker et al. 2012, Marlo 2014, 2015, although this distinction is not particularly relevant here). For the three languages under discussion here, it appears that the object marker is in complementary distribution with a full grammatical object.

⁵Recall that y orthographically represents [j], which is voiced. [k] in *–kubita* ‘to hit’ is voiceless.

- (6) a. *In-dwanyi y-a-ki-yi-kubit-ish-ije.*
 9-soldier 9S-PST-7O-9O-beat-CAUS-PERF
 ‘The soldier beat it with it.’
- b. *In-dwanyi y-a-yi-gi-kubit-ish-ije.*
 9-soldier 9S-PST-9O-7O-beat-CAUS-PERF
 ‘The soldier beat it with it.’

The class 7 object marker alternates between *gi-* and *ki-* depending on the voicing of the consonant in the following syllable. This process of voicing dissimilation is referred to as Dahl’s Law, and is present in several Northeastern Bantu languages (Myers 1974, Davy & Nurse 1982, Pulleyblank 1983). Infinitives in Kinyarwanda are also subject to Dahl’s law, marked with the prefix *ku-* or the allomorphs *gu-* (before a stem with an initial voiceless consonant) or *kw-* (before vowel-initial stems). When a verb is mentioned in prose, I include the infinitive marker with the verb as a citation form, but the infinitive prefix is obviously absent in tensed clauses. Note that many of the noun classes are also subject to Dahl’s law, with voicing being conditioned by the first consonant on the noun stem.

Although Kinyarwanda has a contrastive tone system (Myers 2003), standard Kinyarwanda orthography represents neither tone nor vowel length. I use Kinyarwanda orthographic conventions in all examples. The data collected for Kinyarwanda come from interviews conducted during seven months over three trips to Muhanga and Kigali, Rwanda as well as ongoing interviews with two expatriate speakers living in Austin, TX.

1.2 Chicheŵa

Chicheŵa (Guthrie classification: N31) is spoken in Southeastern Africa by approximately 10,000,000 people mostly in Malawi, but also in Mozambique, Zambia, and Zimbabwe — where it is often referred to as Nyanja or Chinyanja (Lewis et al. 2016).

Table 3 provides the consonant inventory of Chicheŵa. Unlike the other two languages

in the study, Chicheŵa has contrastive aspiration on voiceless plosives. For example, consider the minimal pairs in (7).

- (7) *-ponya* ‘hit’ *-phonya* ‘miss’
-kula ‘grow’ *-khula* ‘rub’

	Bilabial	Labial	Alveolar	Post-Alveolar	Velar
Asp. Plosives	p ^h		t ^h		k ^h
Plain Plosives	p b (β)		t d (d)		k g (g)
Nasals	m		n	ɲ	ŋ
Fricatives		f v	s z	ʃ ʒ	
Affricates			ts dz	tʃ dʒ	
Laterals			l		
Trill			r		
Glides	w			j	

Table 3: Consonant Inventory in Chicheŵa (adapted from Mchombo 2004:11)

It is important to note that the orthographic sequence “kh” in Chicheŵa represents an aspirated voiceless velar plosive; in Lubukusu, as discussed in the next section, this same orthographic sequence represents a voiceless velar fricative. Chicheŵa also stands out from the other two languages in that it has implosive voiced stops. Although these are not contrastive, it is worth noting that many speakers alternate between egressive and implosive articulations.

As in Kinyarwanda, there is not a phonemic contrast between [l] and [r] (or, per Mchombo 2004, [r]), and often speakers would not have a clear intuition on which sound was appropriate. In some instances, the two appear to be in free variation, with speakers using one or the other in different conversations.

Chicheŵa has a rich noun class system, provided in Table 4. A noteworthy fact is that in Chicheŵa, class 2 (the animate plural class in other Bantu languages) is used as to indicate respect on singular nouns. For example, the word *a-gogo* ‘2-grandparent’ can be used to refer to several grandparents or to respectfully refer to a single grandparent. With many words, such as *a-gogo* ‘2-grandparent’, *a-mfumu* ‘2-chief’, *a-bambo* ‘2-man/father’, and

Class		Noun		SM		OM	
SG	PL	SG	PL	SG	PL	SG	PL
1	2	m(u)-	a-	a-	a-	m(u)-	wa-
3	4	m(u)-	mi-	u-	i-	u-	i-
5	6	li-	ma-	li-	a-	li-	wa-
7	8	chi-	zi-	chi-	zi-	chi-	zi-
9	10	N-	N-	i-	zi-	i-	zi-
12	13	ka-	ti-	ka-	ti-	ka-	ti-
14	6	u-	ma-	u-	a-	u-	wa-
15		ku-		ku-		ku-	
16		pa-		pa-		pa-	
17		ku-		ku-		ku-	
18		m(u)-		m(u)-		m(u)-	

Table 4: Noun classes in Chicheŵa (Mchombo 2004:6)

a-mayi ‘2-mother’, the class 2 (singular) prefix is nearly always used due to the inherent respect afforded to these people in Malawian culture. Table 4 provides the noun class prefixes in Chicheŵa. Note that in classes 9/10 the prefix on the noun is a homorganic nasal, matching the place of articulation of the following consonant. Class 11 is not present in Chicheŵa.

The valency-changing morphemes in Chicheŵa that are under discussion in this dissertation are the applicative *-ir/-er* and the causative *-its/-ets*. Examples of these are given in (8) and (9), respectively. The applicative morpheme is used for benefactive, instrumental, and locative applicative sentences.

- (8) a. *A-mfumu a-na-mang-ir-a ny-umba mw-ana.*
2-chief 2S-PST-build-APPL-FV 9-house 1-child
‘The chief built the house for the child. (Benefactive)
- b. *A-mfumu a-na-mang-ir-a ny-umba fosholo.*
2-chief 2S-PST-build-APPL-FV 9-house shovel
‘The chief built the house using the shovel. (Instrumental)
- c. *A-mfumu a-na-mang-ir-a ny-umba pa-phili.*
2-chief 2S-PST-build-APPL-FV 9-house 16-hill
‘The chief built the house on the hill. (Locative)

- (9) *A-mfumu a-na-mang-its-a mw-ana ny-umba*
 2-chief 2S-PST-build-CAUS-FV 1-child 9-house
 ‘The chief made the child build the house.’

The vowel of the applicative and causative morpheme is conditioned by the height of the vowel in the preceding syllable, parallel to the pattern described for Kinyarwanda above.

Chicheŵa has contrastive tone, but as it is not marked in standard orthography, I do not indicate it here. The data collected for Chicheŵa come from interviews conducted during two months with speakers living in Lilongwe as well as in the villages of Gowa and Phonya in Ntcheu district.

1.3 Lubukusu

Lubukusu (Guthrie classification: JE31C) is a Luyia language spoken in Bungoma District in Western Kenya (Lewis et al. 2016). Luyia is a cluster of roughly 23 dialects spoken in Eastern Kenya and Western Uganda. Previous work on Lubukusu has focused on phonology (Mutonyi 2000) and the syntax of agreement (Carstens & Diercks 2013, Diercks 2013), with some work on the relationship between personal pronouns and symmetry in the morphological causative (Baker et al. 2012).

Table 5 provides the consonant inventory of Lubukusu.⁶ One notable difference in Lubukusu is the presence of the voiceless velar fricative [x]. In Lubukusu orthography, this is represented by “kh” (not to be confused with the Chicheŵa convention of using “kh” to indicate an aspirated velar stop). Unlike Kinyarwanda and Chicheŵa, [l] and [r] are contrastive in Lubukusu, as shown by the following minimal pairs.

- (10) *khu-luma* ‘to bite’ *khu-ruma* ‘to send’
 khu-leka ‘to despise’ *khu-reka* ‘to trap’

However, Mutonyi notes that for some speakers, [l] is an allophone of /r/, but the reverse is not true (p.170).

⁶Mutonyi includes prenasalized stops as a category in his description, but then suggests that perhaps that these are not phonemic. See his original work for more discussion (Mutonyi 2000:164-165).

	Bilabial	Labial	Alveolar	Post-alveolar	Palatal	Velar 9
Plosive	p		t			k
Nasal	m		n		ɲ	ŋ
Fricative	β	f	s			x
Affricate				tʃ dʒ		
Glide					j	w
Rhotic			r			
Liquid			l			

Table 5: Consonant Inventory of Lubukusu (Modified from Mutonyi 2000:164)

In Lubukusu, the system of noun classes is more complex than in Kinyarwanda and Chicheŵa in that the noun class marker is divided into a prefix and an augment (also referred to as a “preprefix”) that precedes the prefix. The semantic nature of augments varies greatly in different Bantu languages, with some losing them (e.g. Chicheŵa) and some incorporating them as part of the phonological shape of the noun class prefix (e.g. Kinyarwanda). For a more extensive discussion of augments and prefixes, I refer the reader to Mutonyi (2000:4-36) for Lubukusu and de Blois (1970), Katamba (2003), *inter alia* for Bantu generally.^{7,8}

Classes 16, 16a, 17, 18, and 23 are locative classes, indicating a specific kind of motion or location of the noun.

- (11) a. *a-mu-lyango*
16-3-door
‘at/near the door’
- b. *sya-mu-lyango*
16a-3-door
‘towards the door’
- c. *khu-mu-lyango*
17-3-door
‘on the door’

⁷For the class 1 subject marker, many speakers use the subject marker *ka-*. When asked, speakers said that it was equivalent to *a-*. My impression is that the use of one of these allomorphs depends on the tense of the verb, but I do not explore the constraints here. This is not discussed in Mutonyi’s grammar.

⁸Class 4 serves as the plural for class 20.

Class	Augment	Prefix	SM
1	o-	mu-	(k)a-
2	ba-	ba-	ba-
3	ku-	mu-	kw-
4	ki-	mi-	ky-
5	li-	li-	ly-
6	ka-	ma-	ka-
7	si-	si-	sy-
8	bi-	bi-	by-
9	e-	N-	ya-
10	chi-	N-	chi-
11	lu-	lu-	lw-
12	kha-	kha-	kha-
14	bu-	bu-	bw-
15	khu-	khu-	khu-
16	a-		a-
16a	sya-		sy-
17	khu-		khw-
18	mu-		mw-
20	ku-	ku-	kw-
23	e-		ya-

Table 6: Noun classes in Lubukusu (Mutonyi 2000:6, Wasike 2007:18)

d. *mu-mu-lyango*

18-3-door

‘in the door’

e. *e-naarobi*

23-Nairobi

‘at (in the vicinity of) Nairobi’

These morphemes replace the augment of other noun classes, deriving a locational meaning. In the examples in (11), the class 3 augment is removed from *ku-mu-lyango* ‘door’ and replaced with the desired locative.

As for valency-changing morphology, Lubukusu has one applicative that covers various thematic roles, such as beneficiary, instrumental, and locative. Examples of each of these applicatives, respectively, is given in (12). Note that the applicative morpheme is the same for each of the three thematic roles.

- (12) a. *O-mu-hayi k-a-rem-el-a o-mw-ana ku-mu-sala.*
 1-1-hunter 1S-PST-cut-APPL-FV 1-1-child 3-3-tree
 ‘The hunter cut the tree for the child.’ (Benefactive)
- b. *O-mu-hayi k-a-rem-el-a ku-mu-sala ku-mu-bano.*
 1-1-hunter 1S-PST-cut-APPL-FV 3-3-tree 3-3-machete
 ‘The hunter cut the tree with the machete.’ (Instrumental)
- c. *O-mu-hayi k-a-rem-el-a ku-mu-sala mu-mu-siru.*
 1-1-hunter 1S-PST-cut-APPL-FV 3-3-tree 18-3-forest
 ‘The hunter cut the tree in the forest.’ (Locative)

In addition to the applicative, Lubukusu has two causative morphemes: *-y* and *-esy*. Both have a direct causative meaning; the causer is directly acting on the causee to bring about the caused event. In both sentences in (13), the subject is holding the child’s hand, forcing him to hit the dog.

- (13) a. *A-li-kho ka-p-y-a o-mw-ana e-mbwa.*
 1S-COP-LOC 1S-hit-CAUS-IMP 1-1-child 9-dog
 ‘He is causing the child to hit the dog.’
- b. *A-li-kho ka-p-isy-a o-mw-ana e-mbwa.*
 1S-COP-LOC 1S-hit-CAUS-IMP 1-1-child 9-dog
 ‘He is causing the child to hit the dog.’

The difference between the two is that the *-esy* causative has a pluractional interpretation, where the event takes place many times. In (13b), the subject is making the child hit the dog repeatedly, while in (13a), the interpretation is that the subject hits the dog once.⁹

The data for Lubukusu come from elicitations from two trips to Western Kenya. One trip, for three months, was in Eldoret, Kenya, working with Lubukusu speakers living there.¹⁰ The second trip was a one-month stay in Bungoma, which is the largest town in the Lubukusu-speaking region of Kenya.

⁹To my knowledge, there is no work that has mentioned this difference between the two causatives in Lubukusu, and it may be a different pattern in different Lubukusu-speaking regions. For the speakers I consulted in Bungoma, this pattern was very robust.

¹⁰Eldoret is not in the Lubukusu-speaking region of Kenya, but it is the home of native speaker linguist Justine Sikuku, whose family was gracious enough to host me during my stay.

2 Lexical Semantics and Argument Realization

To date, a paucity of work has investigated how lexical semantics affects argument realization patterns in Bantu. This is surprising given that a large body of theoretical work on lexical semantics in other language families has been fruitful, having shown that the meaning of a particular verb class affects argument realization patterns. One fundamental question that has not been asked about Bantu is whether the realization of an applied object is affected by the meaning of the verb class. This is partly due to the fact that the traditional view analyzes applicativization as an operation that monotonically adds a wholesale new object to the argument structure of a verb without any interaction with verbal meaning. As such, applicativization has been primarily considered interesting only from a morphosyntactic perspective, leaving little discussion regarding the semantics of applicative morphology and how this integrates with verb meaning. This dissertation aims to specifically address this gap in the literature, showing that truth conditional content is crucial in understanding applicative morphology. In this section, I provide a brief overview of work on the interface between argument structure and lexical semantics.

2.1 Empirical Basis

A key finding in work on verbal lexical semantics is that verb meaning affects argument realization patterns, often by restricting which argument alternations a particular verb can participate in. For example, Rappaport Hovav & Levin (1998) outline in detail several grammatical differences between change of state verbs such as *break* and manner verbs such as *sweep*, which follow from the different meanings of the two classes. One difference is that transitive manner verbs often allow the omission of the object, while result verbs do not, as shown in (14), where the verb *sweep* can appear without its object, while the verb *break* cannot.

- (14) a. John swept.

b. *John broke.

Both verb classes permit resultative constructions that describe the result state of the verb's object, such as in (15).

- (15) a. John broke the vase to pieces.
b. Cinderella scrubbed the floor clean.

However, activity verbs can permit a range of arguments that are not subcategorized for by the verb, while the change of state verbs do not. In this context, a non-subcategorized object is an object that is not the participant being directly affected by the action described by the verb. In (16a), for example, the fingers are not the things being scrubbed, but rather they become raw as a result of scrubbing something (e.g. the floor). The crucial contrast is that a corresponding meaning is not possible with the change of state verb *break*: in a context where the child broke many things, and as a result his knuckles were hurt, the sentence in (16b) is not felicitous.

- (16) a. Cinderella scrubbed her fingers to the bone.
b. *The clumsy child broke his knuckles to the bone.

(Rappaport Hovav and Levin 1998:103,(6))

The examples in (14) – (16) show some of the similarities and differences in argument realization patterns with *break* and *sweep*, which are typical of the broader classes of caused change of state and activity verbs, respectively (Rappaport Hovav & Levin 1998). The crucial point here is that the meaning of a particular verb affects the kinds of syntactic configurations in which it may appear.

Another domain where argument structure is constrained by verb class is the realization of ditransitive verbs with either a double object or *to*-oblique frame (Green 1974, Pinker 1989, Goldberg 1995, Rappaport Hovav & Levin 2008, Beavers 2011a). Although participation in this alternation is common across ditransitive verbs, ditransitives from different

classes vary in the nature of the meanings that are available with the two frames. For some verbs, such as *give*, *hand*, *bequeath* and *tell*, there is a caused possession reading across both the double object and *to*-oblique frames, as in (17a-b), respectively.

- (17) a. John gave Mary the present. (DO Frame)
b. John gave the present to Mary. (*to*-oblique Frame)

Other verbs, such as *send*, *throw*, *bring*, and *take*, instead allow either a caused motion or a possession meaning, though the realization of the objects in the different frames are associated with different meanings. In the double object frame, the reading is restricted to caused possession, while in the *to*-oblique frame, the reading is either caused motion or caused possession. With the verb *send*, for example, the double object frame in (18b) is only felicitous if *London* is understood as an office in London, and thus a possible recipient of the package. In (18a), on the other hand, *London* can be interpreted as either the location or as an office in London.

- (18) a. John sent the package to London.
b. #John sent London the package.

However, with other verbs, the pattern changes. Recall that *give* requires that both frames have a caused possession reading, which means that, unlike *send*, both frames with *give* do exhibit the London Office Effect, where *London* in (19) must be interpreted as a recipient.

- (19) a. #John gave the package to London.
b. #John gave London the package.

In both frames in (19), the sentence is infelicitous unless *London* is interpreted as a recipient (e.g. John is donating the package to the city of London), crucially differing from the pattern with *send* in (18) where the *to*-oblique frame permits the caused motion reading (see Rappaport Hovav & Levin 2008 and Beavers 2011a for discussion of the relationship between verb class and different realization frames).

The key insight to be drawn from data such as that in (14) – (16) and (17) – (19) is that these patterns exemplify the kinds of argument structural variation that arises from verbs within particular classes. (See Levin 1993 for a broad overview of various other argument alternations in English and Levin & Rappaport Hovav 2005 on the role of verb meaning in the realization of arguments. See also Beavers 2010 for a discussion of this point with a range of argument alternations.)

Various perspectives have been proposed for modeling verb meaning and how it affects argument realization. I turn now to a broad summary of some of the major views in how to model verbal meaning in order to capture the variation across verb classes for the argument realization patterns they exhibit.

2.2 Thematic Roles

One early approach to explaining the importance of lexical semantics to argument realization was to relegate grammatically relevant generalizations to the thematic roles assigned by the verb to its arguments (Fillmore 1968, 1970). On this view, semantic roles are considered to be a small set of semantically unanalyzable role labels which exist independently of the meaning of the verb. Argument realization (such as mapping to subject or object) follows from the semantic roles associated with the verb class via some set of “linking rules”, such as Fillmore’s (1968) subject selection rule, which maps the highest ranked semantic role on a particular hierarchy (e.g. *ag>inst>patient*) to subject. Verbs that assign different thematic roles will thus exhibit different argument realization patterns.

For example, Fillmore (1970) describes various argument structural differences between the two classes of verbs in (20), typified by the verbs *hit* and *break*.

- (20) a. *Break* Verbs: bend, fold, shatter, crack
b. *Hit* Verbs: slap, strike, bump, stroke (Fillmore 1970:125,(15-16))

Despite some seeming similarities between the two classes, such as the fact that the verbs

in both the classes in (20) are transitive, *hit*-type and *break*-type verbs exhibit various argument structural differences. One similarity is that it is possible to have an instrument subject with both verbs, as in (21).

- (21) a. The stick broke the window.
b. The stick hit the window.

However, one difference between the two is that *hit* verbs cannot appear in the inchoative, while *break* verbs can, as shown in (22).

- (22) a. The window broke.
b. *The window hit.

Another difference between the two is that with *hit*, it is possible to have possessor ascension, while with *break* it is not, as shown in (24), where the possessor of the affected limb is the direct object of the verb.

- (23) a. I hit his leg.
b. I broke his leg.
- (24) a. I hit him on the leg.
b. *I broke him on the leg.

Fillmore argues that these differences follow from the semantic roles assigned to the arguments of the verbs in the two classes, proposing the thematic role lists for *hit* verbs and *break* verbs in (25). In Fillmore's notation, a noun in parentheses is optional, and the convention of putting the two parenthesis-enclosed nouns immediately adjacent in (25b) indicates that one of the two nouns must be present.

- (25) a. *break*: (agent) (instrument) object
b. *hit*: (agent)(instrument) place

The classes are similar in that they both have an agent and an instrument (though with *hit* either the agent or instrument must be present), while the two differ in that *break* verbs have an object role (a “patient” in subsequent terminology) while *hit* verbs have a place role (or “location”). The difference in thematic roles of the two classes captures the empirical variation between the two classes of verbs. For example, with both classes of verbs it is possible to have an instrument subject, captured by the fact that an instrument is an available role in argument structure of both *hit* and *break*. *Hit*-type verbs, however, require either an agent or an instrument, which captures the inability of these verbs to appear in the inchoative, as in (22b). Furthermore, the differences in the thematic roles of the two verbs captures their divergent behavior with possessor ascension; on the assumption that the place role is permitted to appear as a locative prepositional phrase, this allows *hit* to exhibit possessor ascension as in (23a) where the place appears as an oblique phrase. The object role, however, cannot appear in such an oblique, which in turn means that *break*, on the other hand, cannot appear in the possessor ascension construction, as shown above in (24b).

However, the use of semantic roles to drive argument structural generalizations has been largely abandoned in most work on argument realization for various reasons, such as the difficulty in defining the appropriate number of grammatically relevant roles as well as the difficulty in stating semantic constraints on possible verb classes based solely on semantic roles (see Dowty 1989, 1991a, Croft 1991, 1998, Levin & Rappaport Hovav 2005 for critical discussion). However, the convention of labeling the thematic role of an argument persists in the literature as a notational convenience.¹¹

2.3 Event Structures

A separate view subsumes thematic roles under a notion of so-called “event structures,” which deconstruct the meaning of a verb into causal or temporal subevents (depending on the theory). Generally, there are assumed to be two major components to the event struc-

¹¹Though see the discussion of Dowty in §2.4 for a different conception of thematic roles.

ture of a given verb. The first component is an event template, encoding general semantic notions about the kind of event that the verb describes. These general components are a small, limited set of event predicates such as CAUSE, BECOME, etc. The second component is a much larger set of idiosyncratic verb-specific meanings that distinguish each verb from similar verbs in the same class, now usually called the lexical semantic root (or just root for short). This basic division is accepted in almost all work on event structures, though perspectives differ as to whether the event structures are lexical (Dowty 1979, Jackendoff 1990, Levin & Rappaport Hovav 1995, Wunderlich 1997), syntactic (Lakoff 1965, Hale & Keyser 1993, Harley 2003, Ramchand 2008), or constructional (Goldberg 1995, Kay 2005).¹² Generally, it is only the template, and not the root, which is assumed to be grammatically significant to argument realization, an assumption persistent across all event structural approaches.

By means of illustration, consider externally caused change-of-state verbs in English such as *break*, *warm*, *cool*, *reddden*, *melt*, and *dissolve*. Each of these verbs (in its transitive use) is an event which describes an agent participant who acts in a way which results in a change of the state of the theme. All of these verbs, then, would have a similar event structure, such as that in (26), following the notation used in Rappaport Hovav & Levin (1998).

(26) [[*x* ACT] CAUSE [*y* BECOME ⟨ ROOT ⟩]]

The verb template in (26) describes what is arguably shared across all caused change-of-state verbs, with the root being what differentiates individual verbs within the class (i.e. that state that is described by the verb to occur as a result of the causing event). The event structures for the verbs *break* and *warm* would look like those in (27a) and (27b), where the only difference between the two is the meaning of the root.

¹²I do not engage with this debate here. Instead, I present an empirically-driven, ideally theory-neutral analysis of applicative morphology in Bantu within the context of a theory of event structures more broadly, which, in principle, could be implemented in a lexicalist, syntactic, or constructional conception of verb meanings.

- (27) a. $[[x \text{ ACT}] \text{ CAUSE } [y \text{ BECOME } \langle \textit{broken} \rangle]]$
 b. $[[x \text{ ACT}] \text{ CAUSE } [y \text{ BECOME } \langle \textit{warm} \rangle]]$

The core intuition of these approaches is thus that while verbs of a specific class share the same grammatical properties (such as an agent subject and a theme object that is changed as a result of the action), each verb has idiosyncratic information that distinguishes it from other verbs of the same broad class. By means of comparison, consider another class, such as activity verbs like *run*, *jog*, *creak*, *whistle* and *laugh*. These verbs, in contrast to the caused change of state verbs, have the event structure in (28).

- (28) $[x \text{ ACT}_{\langle \textit{root} \rangle}]$

In (28), there is a single participant and a single subevent of acting in a manner specified by the particular verbal root. Consider the event structures of *run* and *scream* in (29a) and (29b).

- (29) a. $[x \text{ ACT}_{\langle \textit{run} \rangle}]$
 b. $[x \text{ ACT}_{\langle \textit{scream} \rangle}]$

Argument realization in this approach arises via rules linking the event structures and the argument structure. These linking rules between event structure and syntax often rest on the key insight that semantic prominence of an argument in the event structure largely determines its syntactic prominence, a notion referred to as “prominence preservation” in Levin & Rappaport Hovav (2005:140-145). Specifically, the highest argument in an event structure is expressed as the subject (Wunderlich 1997). This ensures that the causer argument in the causative variant of *break* is the subject, while patient is the subject in the inchoative variant of *break*. The event structures in (30) correspond to the sentences in (31).

- (30) a. $[[x \text{ ACT}] \text{ CAUSE } [y \text{ BECOME } \langle \textit{broken} \rangle]]$
 b. $[y \text{ BECOME } \langle \textit{broken} \rangle]$

- (31) a. John broke the vase.

b. The vase broke.

The causer argument in (30a) is the subject in (31a), while the patient argument in (30b) is the subject in (31b). In both cases, the highest argument in the event structure is the subject, i.e. the highest argument in the clause, thus maintaining prominence preservation.

While in lexicalist approaches prominence preservation is maintained through linking rules, with syntactic models of event structures, a key goal has been to derive prominence preservation without linking rules (Hale & Keyser 1993, 1997, 1998, 2002, Pesetsky 1995, Harley 2003, Folli & Ramchand 2005, Ramchand 2008, *inter alia*). On these views, prominence preservation is instead maintained by treating event structures as syntactic objects, with functional heads paralleling the sub-lexical operators in the lexicalist event structures. In one version of this analysis, a functional head v^0 is either CAUSE or BECOME and selects a \sqrt{P} (root phrase) which contains the root meaning of the verb (Harley 1995, Marantz 1997, Harley 2008). In this particular style of analysis, the lower $\sqrt{}$ moves to the higher v^0 head, head-adjointing to v^0 .

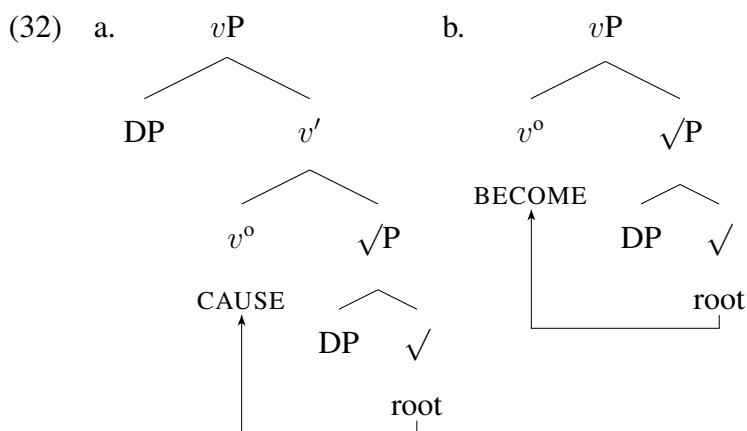

(Harley 2008:47,(30))

In (32a), the head v corresponds to CAUSE in (26), present in a verb like *break*; in (32b), on the other hand, v corresponds to BECOME, which would correspond to an intransitive unaccusative verb, such as *open*. Here there is no need for linking rules to maintain prominence preservation; the highest argument in the event structure is also the highest argument

in the syntactic structure by virtue of the fact that the event structure *is* the syntactic structure.¹³ Despite the fact that the predicate is splayed out in the syntax in the configurational view instead of lexically specified, the core insight from both views is that verbal meaning can be deconstructed into a template (in (32), the template is the syntactic structure) with idiosyncratic roots that indicate the meaning of a particular verb.

Returning to the analysis of applicatives, it has been tacitly assumed that an applicative morpheme adds a new object and associated thematic role into the argument structure, analyzable in an event structural analysis as an operation that adds a new event structural chunk that introduces a new argument. For example, many syntactic approaches to event structure analyze the applicative as an Appl head that is merged either above or below the VP.¹⁴ Note that the V head in (33) corresponds to \sqrt{P} in the structures in (32), essentially differing only in formal notational convention.

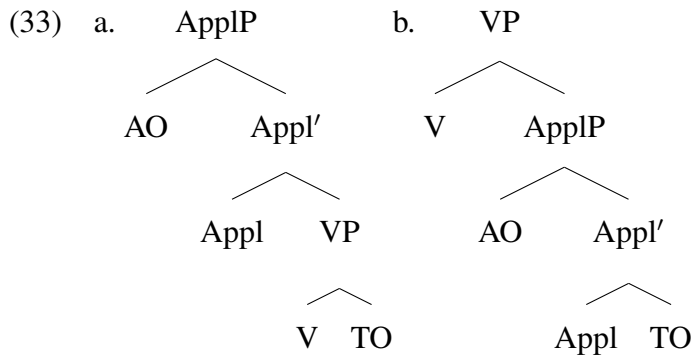

(Pylkkänen 2008:14,(6))

In this theory, the so-called “High” applicative in (33a) relates the applied object (AO) to the VP (and thus to an event), putatively giving a beneficiary reading. In the so-called “Low” applicative in (33b), however, the applicative head instead relates the applied object to the thematic object (TO), giving a recipient reading. This is one area in which event

¹³However, it could be argued that the movement of arguments at different stages of the derivation parallel the linking rules of lexicalist approaches. What is unique about syntactified approaches to argument structure is that all generalizations of prominence are coded syntactically at some level of the derivation.

¹⁴To the best of my knowledge, there has been no comparable lexicalist approach to applicatives in the event structural literature that I am aware of, though the presumed function of applicatives would be analyzed in a similar fashion. Another body of work in Lexical Functional Grammar (LFG) has also provided an account of applicatives based on how the thematic role of the applied object figures into the syntactic facts of the applied object (Bresnan & Moshi 1990, Alsina & Mchombo 1993, Harford 1993). I discuss this view in detail in Chapter 5.

structural representation supposedly matters for interpreting applicatives since the position of the applicative in the template and the type of its arguments is crucial, though I show in Chapters 4 and 5 that there are various empirical points that this framework fails to capture, including the interaction with the rest of the verb's meaning. Furthermore, this high-low distinction has been claimed to figure into syntactic facts such as object symmetry. I discuss this in Chapter 5 where I present various issues with tying object symmetry facts to syntactic structure. However, the key point here is that by treating applicatives as introducing new structure into event templates, it is predicted at least in principle that there should be syntactic and semantic facts that correlate with this typology.

2.4 Lexical Entailments

An emergent fact about event structural approaches to verb meaning is that proponents of this view aim to derive argument structure facts at least partly from representational issues of event structures, and in many cases, facts about argument realization are indeed tied to the structure of the representation (such as subject/object selection). For example, the position of an argument within an event structure figures into whether it is the subject or not, something that holds regardless of what kind of event, semantically speaking, that the event structure describes. Thus argument realization is linked at least in part to the structure of the representation, regardless of the semantics. Implicitly or explicitly, this reliance on event structural representation for deriving argument realization is assumed in most work on argument realization (see Beavers 2010, Beavers & Francez 2012 for discussion of these points). However, certain other argument structural generalizations have been claimed to be tied directly to the truth-conditional content regardless of the event structural representation.

Work in this tradition captures grammatically relevant information in terms of broad lexical entailments regarding the events and participants described by the verb and how

different syntactic realizations of arguments correlates with the entailments associated with those arguments (Ladusaw & Dowty 1988, Dowty 1989, 1991a, Primus 1999, Ackerman & Moore 2001, Beavers 2010). Consider, as a point of illustration, Dowty (1991a), whose approach derives subject and object selection from the entailments associated with the arguments of a particular verb. The key insight here is that every verb has a predicate argument structure, and its meaning is an association of its arguments with a set of lexical entailments, namely, the set of things that must be true of a particular argument in order for it have have that particular role in the event. Each verb has its specific “individual thematic roles” (a term from Dowty 1989:76) that it assigns to its own arguments, and the intersection of individual thematic roles provides “thematic role types” (Dowty 1989:77). Of these roles, Dowty (1989) distinguishes “L-thematic role types,” which are those thematic role types which are relevant to linguistic generalizations across a range of verbs. However, certain grammatical functions (arguably, subject and object) are not associated with necessary or sufficient lexical entailments. Instead, the entailments which figure into subject and object selection form prototypes or “Proto-Roles.” Dowty (1991a) provides the roles of Proto-Agent and Proto-Patient in (34) and (35), respectively.

(34) Proto-Agent Lexical Entailments (Dowty 1991:572,(27))

- i. volitional involvement in the event or state
- ii. sentience and/or perception
- iii. causing an event or change of state in another participant
- iv. movement relative to the position of another participant
- v. exists independently of the event named by the verb

(35) Proto-Patient Lexical Entailments (Dowty 1991:572,(28))

- i. Undergoes change of state
- ii. incremental theme

- iii. causally affected by another participant
- iv. stationary relative to movement of another participant
- v. does not exist independently of the event, or not at all

On Dowty's approach, the argument with the most Proto-Agent entailments maps to subject, while the argument with the most Proto-Patient entailments maps to object. Consider the transitive verb *break* in (36).

(36) The child broke the cup.

In this sentence, *the child* maps to subject as it has the most Proto-Agent entailments (the argument is volitional, sentient, and causes a change of state in another participant), while *the cup* maps to object as it has the most Proto-Patient entailments (the argument undergoes a change of state, and it is causally affected by another participant). Note that an argument need not have *all* of the Proto-entailments of a given role, but crucially it must have more than the other argument.

The intuition behind this style of analysis is that at least some argument realization facts (e.g. of the subject and object in the case of Dowty 1991a) follow from the sets of entailments related to the participant and not from the semantic representation from which these entailments are derived. In other words, constraints on argument realization are stated directly on truth conditional content. However, it is worth pointing out that Dowty's approach and those that follow it are not incompatible with assuming event structures, and in fact, the two views most likely complement each other in understanding how lexical semantics influences argument realization (see Beavers 2010:857-858 for discussion).

2.5 Summary

Various methods have been proposed for analyzing the relationship between the lexical semantics of verb meaning and the argument structure of a given verb. One method is to

derive syntactic facts from the thematic roles of the arguments, while another view drives syntactic facts from event structural representations. Finally, the truth-conditional content also plays a role in argument structure, dovetailing with event structural representations of the event structure. In the discussion over the next two chapters I show that both event structural information as well as truth-conditional content related to the arguments of applied and non-applied predicates conspire to derive the syntactic and semantic uses of applicative morphology.

3 Elicitation Methodology

Before I begin the analysis, I briefly comment on the sources of the data used. Much of the data presented in this dissertation were collected by the author from native speakers of the three languages. The data were collected over three separate trips to Eastern Africa, with approximately 10 to 20 total speakers consulted for each of the languages. Three months were spent in Rwanda in the summer of 2012; three months in Kenya and three months in Rwanda in the fall of 2013; and two months in Malawi, two weeks in Rwanda, and one month in Kenya in the summer of 2015.

In Malawi, three primary consultants were interviewed with various other speakers participating in group settings or via translation. Similarly in Kenya, three speakers of Lubukusu participated as primary consultants for the symmetry data, and three different key consultants were interviewed for the data on caused ingestive verbs in Chapter 5. Finally, for Kinyarwanda, four participants provided judgments for the symmetry data.

For the chapter on locative applicatives, two Rwandese expatriates living in Austin were the main consultants for the project, though many of the same speakers from the object symmetry portion were also consulted. The judgments from the chapter on causative-instrumental syncretism come mostly from one primary consultant in Rwanda as well as various other supplementary judgments from the four consultants who provided judgments

for the symmetry data.

For the comparative study on the symmetry properties of each of the languages, the project began by asking consultants for each language for a translation of the non-applied use of the relevant verbs (see Chapter 5 for discussion of the verbs used in this study). Then, the applied variant was elicited with the benefactive, instrumental, and locative applied object, generally by using knowledge of previous work to construct appropriate examples; in addition, the morphological causative was elicited for each verb. Once a base applied sentence was elicited for each verb, I proceed to construct sentences for judgments from speakers on whether a particular argument can undergo a particular diagnostic. To the degree possible, contexts were created to make the sentences sound natural. Generally, sentences were elicited once, but confirmed by other speakers as much as possible. Often elicitations were conducted in small groups, with several speakers providing their judgments simultaneously.

For the topics covered in the other chapters, both translation was used as well as constructed examples which were judged as felicitous/grammatical by speakers. Throughout the dissertation, any data presented without a citation is data that is taken from the author's notes. Any data taken from prior published literature is cited as such.

Chapter 3: The Locative Applicative and the Semantics of Verb Class

1 Introduction

As discussed in Chapter 1, the traditional analysis of applicatives assumes that a new applied object is monotonically added to the argument structure of the verb and one of a specific set of thematic roles is assigned to that object. Consider the example in (1) from Kinyarwanda, where the beneficiary object *umwana* ‘child’ is licensed by the applicative *-ir*.

- (1) a. *Umu-gabo a-r-andik-a in-kuru.*
1-man 1S-PRES-write-IMP 9-story
‘The man is writing the story.’
- b. *Umu-gabo a-r-andik-ir-a umw-ana in-kuru.*
1-man 1S-PRES-write-APPL-IMP 1-child 9-story
‘The man is writing the story for the child.’

While the transitive verb *kwa-ndika* ‘write’ in (1a) licenses a single thematic object, the applied variant in (1b) has two post-verbal DPs: the thematic object and the applied object.

The syntactic literature has focused predominantly on the syntactic nature of the applied object. Research into so-called “object symmetry” compares the grammatical status of the applied object to the status of the thematic object. While there has been considerable theoretical debate on how to model the difference between objects (e.g. Gary & Keenan 1977, Kimenyi 1980, Baker 1988, Bresnan & Moshi 1990, Alsina & Mchombo 1993, Jeong 2007, Pyllkkänen 2008, Jerro 2015, and see also Chapter 5), a question that has received considerably less attention is the range of thematic roles that are possible with the applied object, and, in particular, whether the lexical semantics of the verbal root matters in determining this.

As mentioned in Chapter 2, research in lexical semantics has shown that the semantics of particular verb classes can have a crucial effect on argument realization patterns, includ-

ing which argument alternations verbs may occur in and what interpretation the alternating frames have (Fillmore 1970, Levin 1993, Rappaport Hovav & Levin 2008, Beavers 2011a, *inter alia*). As valency-changing morphemes, applicatives (canonically) add a new argument to the argument structure of the verb, and as such, it is reasonable to hypothesize that the argument-adding behavior of applicatives might be sensitive to the semantic class of the verb, in a similar way to argument alterations in other languages.

In this chapter, I show that this hypothesis is in fact borne out: semantic verb class indeed figures into the semantic effect of the applicative morpheme, with the thematic role of the applied object being at least partly conditioned by the verb. Specifically, there is a rich interaction of locative applicatives with different verbs of motion, first noted in Jerro (In Press) where the semantic role of the applied object differs depending on whether and what kind of motion is already encoded by the base verb. To date, no approach has described nor analyzed the variation in interpretation of the semantic role of the locative applicative with verbs from different classes, and the tools that have been traditionally used to analyze the semantics of applicatives are insufficient to explain such facts.

Furthermore, it was also noted in Chapter 1 that the applicative does not always license a new syntactic object, but instead, in some cases it modifies the thematic role of the existing object of the verb. For example, in Kinyarwanda the ditransitive verb *gu-tera* ‘to throw’ does not gain a new syntactic object when the applicative is used. Rather, the existing goal argument is reinterpreted as a recipient under applicativization. Cases like *gu-tera* ‘to throw’ further problematize the traditional view that applicatives add a new object, as there are clear instances where this addition does not occur.

In order to explain these facts, I analyze applicativization more broadly as subject to paradigmatic semantic constraint on the semantics of an internal argument of the applied verb, where the relevant semantic contrast is in the strength of the truth conditions. Specifically, the applied variant encodes a stronger set of truth conditions associated with an

internal argument of the verb than the corresponding non-applied verb. Verbs from different classes satisfy this paradigmatic constraint in various constrained ways, though in all cases there is addition of some participant-related information (either semantically, syntactically, or both) that is not present with the non-applied variant. This analysis captures not only the cases that have been the focus of generative work where there is a new object and a new associated semantic role, but it also provides a frame of analysis for cases where there is no new object, and for a class of cases I propose involve giving objecthood status to an otherwise semantically implicit participant already part of the meaning of the verb that is otherwise left unexpressed. Finally, on this approach, it is naturally captured that verbs from different classes can show different behavior under applicativization, as the applicative is not necessarily analyzed as a fully productive morphosyntactic operator, but rather as part of a lexicalized morphological process subject to semantic constraints that are satisfied in different ways with particular verb classes.

In the next section, I describe the locative applicative and other kinds of locative morphology in Kinyarwanda. In Section 3, I show that verb class is crucial in determining the semantic role that is assigned to the applied object, and in Section 4, I provide a formal semantic analysis that accounts for the diversity of meanings and uses discussed, capturing the traditional syntactic uses of the applicative as well as instances where no argument is added. Section 5 concludes.

2 Locatives and Locative Applicatives

In this section I describe the various grammatical components of describing locational information in Kinyarwanda, focusing on the locative applicative *-er*, the class of locative pronominal clitics *-ho*, *-yo*, and *-mo*, and the locative class prefixes *ku*, *mu*, and *i*. I fold in data from several other Bantu languages with the goal of situating Kinyarwanda into the considerable variation in the function of different locative forms across Bantu. It is also

important to note that very little of the variation that is described and cited in this section has been incorporated into broader generative work on applicatives, and in many cases, the semantics of these forms has been almost completely unanalyzed.

2.1 Locative Applicatives

Two locative applicatives have been described for Kinyarwanda. One is a class of morphemes that attach at the end of the verbal complex. Depending on the semantics of location (e.g. ‘at’ or ‘inside’), either *-ho*, *-yo*, or *-mo* is used (Kimenyi 1980, Zeller 2006, Zeller & Ngoboka 2006).¹ Consider the data in (2) from the influential grammar by Alexandre Kimenyi.

- (2) a. *Umugóre y-oohere-jé umubooyi kw’ iisóko.*
 woman 1S-send-ASP cook to market
 ‘The woman sent the cook to the market.’
- b. *Umugóre y-oohere-jé-ho isóko umubooyi.*
 woman 1S-send-ASP-LOC market cook
 ‘The woman sent the cook to the market. (Kimenyi 1980:89,(1))

In Kimenyi’s dialect, the applicative *-ho* is in complementary distribution with what he assumes is the locative prepositions *ku* (or *kw’* preceding vowel-initial words) ‘to’,² and the applied locative object is bare in (2b). Furthermore, for Kimenyi, the locative object must precede the thematic object in the applicative sentence in (2b).

Kimenyi (1980) also notes a locative applicative use of the morpheme *-er* (pp. 36–38), which is used for licensing several other thematic types of applicative, such as benefactives and so-called “reason applicatives.” The applicative morpheme *-er* is cognate to the form used in the majority of other Bantu languages.

¹Note that *-ho* and *-mo* correspond to the locative class prefixes *ku-* and *mu-*, which are classes 17 and 18, respectively. As for *-yo*, it is not as clear phonologically, but I assume that it relates to the class 23 locative prefix *i*.

²See §2.2 for a different analysis of these forms.

- (3) a. *Abáana ba-ra-kin-a amákáráta kú mééza.*
 children 2S-PRES-play-ASP cards on table
 ‘The children are playing cards on the table.’
- b. *Abáana ba-ra-kin-ir-a amákáráta kú mééza.*
 children 2S-PRES-play-APPL-ASP cards on table
 ‘The children are playing cards on the table.’ (Kimenyi 1980:36,(24))

In (3b), the applicative *-er* licenses a locative argument, though note that the applied locative is still marked with a locative prefix, despite the presence of the applicative morpheme (see §2.2). Kimenyi indicates that there is a semantic difference between the two sentences in (3), with the applied predicate ‘putting emphasis on the locative’ (p. 36).³ This applicative, however, was not the focus of his discussion of locative applicatives, and all subsequent work citing his data have only cited the *-ho* type applicative in (2).

It is crucial to note, however, that there is dialectal variation with respect to the grammatical status of the *-ho* morpheme. While for Kimenyi and others (e.g. Paul Ngoboka, cf. Zeller & Ngoboka 2006, 2014) this morpheme behaves as an applicative, for the roughly two-dozen Kinyarwanda speakers consulted for this dissertation, none has accepted the applicative use of the *-ho*, *-yo*, and *-mo* morphemes. Instead, these morphemes are anaphoric in nature and refer to a location that is understood from discourse.⁴ For example, the sentence in (4a) would be used in a context where two speakers are discussing a specific location, such as a house, e.g. as a response to a question regarding whether someone is currently entering the house. Similarly, the sentence in (4b) could be used as a response to a question about whether someone is entering a specific country.

³Several consultants have also shared this intuition when asked about the difference between sentences with and without the applicative, as in (3).

⁴The exact point of sociolinguistic variation that underlies this difference is not clear. The speakers consulted for this project have lived in either Muhanga or Kigali, Rwanda, the two largest cities in the country. They have ranged from 18 to their late 40s. I leave the sociolinguistic situation aside here, focusing on the dialect of the speakers that I have consulted. Additionally, it has been pointed out to me by other researchers of Bantu languages that they have also questioned the status of these different applicatives in different dialects.

- (4) a. *N-di kw-injir-a=mwo.*
 1SG-BE INF-enter-IMP=LOC
 ‘I am entering inside there (e.g. the house).’
- b. *N-di kw-injir-a=yo.*
 1SG-BE INF-enter-IMP=LOC
 ‘I am entering there (e.g. a country).’

Here, the locative morphemes describe a location that has been previously mentioned in the discourse, behaving similarly to pronouns. Crucially, there is no applied object licensed by the morpheme, and this morpheme is in complementary distribution with a full locative phrase.⁵ The data cited throughout the rest of this dissertation come from judgments given by speakers for whom *-er* is a locative applicative, such as in (3), and *-ho*, *-yo* and *-mo* are pronominal locative clitics, which I return to in §2.3.

2.1.1 Uses of the Applicative

The most widely discussed use of the locative applicative is to convey that an event takes place in a general location described by the applied object. Consider the following cited example from Chicheŵa in (6).

- (6) *Alēnje a-ku-lúk-ír-a pa-mchēnga mikêka.*
 2-hunter 2S-PRES-weave-APPL-FV 16-3-sand 4-mats
 ‘The hunters are weaving mats on the beach.’

(Chicheŵa; Alsina & Mchombo 1993:41,(44a))

In this example, the locative object is licensed by the applicative, and the interpretation is that the event taking place is related to some general location, such as a beach in (6).⁶

⁵As an aside, there is also a use of these morphemes as adverbial intensifiers:

- (5) *Mw-ara-muts-e-ho*
 1PL-PST-spend.night-PERF-LOC
 ‘Very good morning’.

Mwaramutse is the standard greeting for “good morning” in Kinyarwanda, and the addition of the *-ho* intensifies the greeting. I do not provide an account of this use here, but this use of *-ho* in addition to its use as a locative clitic is a promising area for future research.

⁶The order of objects in (6) is not grammatical for the speakers of Chicheŵa I consulted. See Chapter 5 for discussion of word order with locative applicatives.

The “on” interpretation arises from the locative prefix *pa-* on the locative object. Here, the applicative adds to the meaning of the verb a location that describes where the event took place. Consider also the Kinyarwanda example in (7), where the locative phrase is added via applicativization in (7b).

- (7) a. *Habimana a-ri ku-vug-a (*mu nzu).*
 Habimana 1S-BE INF-talk-IMP 18 house
 ‘Habimana is talking.’
- b. *Habimana a-ri ku-vug-ir-a mu nzu.*
 Habimana 1S-BE INF-talk-APPL-IMP 18 house
 ‘Habimana is talking in the house.’ (Kinyarwanda)

In this example, the applicative provides the location at which the event took place. Crucially, a locative phrase is not grammatical with the non-applied variant of the verb in (7a), and the locative prefix *mu* is obligatory in (7b). I return to the grammatical nature of locative prefixes in Kinyarwanda in §2.2. The important point here is that for nearly all of the generative literature on applicatives, the only use of the locative that has been considered is the kind of use described in (6) and (7), where the applicative adds a new locative object to the verb with a general location reading.

However, it has been noted in the literature on directed motion that the applicative in some languages can encode a goal argument, with the general locative reading being reserved for the non-applied predicate (Schaefer 1985, Sioe 1996). For example, consider the data in (8) from Setswana (S31; Botswana). In (8a), the locational NP describes a general location when the verb does not have an applicative, while in (8b), the applicative *èl* indicates that the locational NP represents the goal of the motion event.

- (8) a. *mò-símàné ó-kíbítl-à fá-tlàsé gá-dì-tlhàrè.*
 1-boy 1S-run.heavily-IMP NEARBY-under LOC-8-TREE
 ‘the boy is running with heavy footfall under the trees.’

- b. *mò-símàné ó-kíbítl-èl-à kwá-tlàsé gá-thàbà.*
 1-boy 1S-run.heavily-to-IMP DISTANT-under LOC-mountain
 ‘The boy is running with heavy footfall to under the mountain.’

(Setswana, Schaefer 1985, Tables VI-VII)

In this example, the applied object is crucially interpreted as the goal of motion, and not as a general location at which the event occurred, such as was the case with the data in (6) and (7). An unresolved question in these studies, however, is the syntactic difference between the locative phrase in (8a) and the locative phrase in (8b). Presumably, via applicativization, the locative in (8b) is an argument of the verb, though in (8a) its status is less clear. Below in §2.2, I provide an argument for these properties in Kinyarwanda, though these properties vary considerably from language to language. Regardless of the syntactic difference in (8a) and (8b), semantically, the locative phrase is a general location in the non-applied predicate, while it is a goal in the applied predicate.

While in the Setswana example the locative in the non-applied predicate is a general location, there is also a related pattern in other languages where the locative in the non-applied predicate is interpreted as a source, and the applied locative is interpreted as a goal. Consider the following examples from Luganda (JE15; Uganda) and Chishona (S10; Zimbabwe) in (9) and (10).

- (9) a. *Abaana badduka mu nnyumba.*
 children run in house
 ‘The children are running out of the house.’
- b. *Abaana badduk-ir-a mu nnyumba.*
 children run.APPL-ASP in house
 ‘The children are running into the house.’ (Luganda, Ashton et al. 1954)
- (10) a. *Grace a-ka-tsair-a ma-ra (ku-bv-a) mu-mba.*
 1a.name 1S-PST-sweep-FV 6-dirt INF-COME-FV 18-room
 ‘Grace swept dirt from the room.’

- b. *Grace a-ka-tsvair-ir-a ma-ra mu-mba.*
 1a-name 1S-PST-sweep-APPL-FV 6-dirt 18-room
 ‘Grace swept dirt into the room. (Chishona; Cann and Mabugu 2007:237,19)

In the (a) sentences in (9) and (10), the non-applied locative specifies the source of motion. In the (b) sentences, the applied object is instead interpreted as a goal. As with (8), it is again not clear what the syntactic nature of the locative is in sentences without the applicative.

In several languages, then, it has been pointed out that the role of the locative applied object is not always just a general location; in certain cases the applied object is a goal. I return to this in §3, where I show that in Kinyarwanda there is a more elaborate pattern where locative applied objects may be a source, route, goal, or general location, and which of these roles is assigned to the applied object is conditioned by the meaning of the verb.

2.2 The Status of Locative Prefixes

Unlike other applied objects, which are generally unmarked nouns, the applied object that is licensed via the locative applicative is often (though not always) marked with locative morphology (such as *ku*, *mu* and *i* in Kinyarwanda) which precedes the located noun. These forms are traceable to Proto-Bantu (Maho 1999), though there is considerable variation with respect to the status of these prefixes in the modern languages. The largest point of variation is the degree to which the locative-marked phrases are treated as arguments or adjuncts (Bresnan & Kanerva 1989, Bresnan 1994, Rugemalira 2004). For example, in some languages, a locative phrase is possible if it is selected as a core argument of the verb, such as in Kerewe (E24; Tanzania) in (11) and Nyakyusa (M31; Tanzania) in (12).

- (11) a. *ta mu-mufuko*
 put 18-bag
 ‘put in bag’
- b. *sanga mu-chumba*
 find 18-room
 ‘find in the room’ (Kerewe; Rugemalira 2004:286,(15-16))

- (12) a. *bika mu-nyambe*
 put 18-bag
 ‘put in bag’
- b. *mwaga ku-kaya*
 find 17-home
 ‘find at home’ (Nyakyusa; Rugemalira 2004:286,(21-22))

In other languages, the locative may also be licensed by a locative applicative, as in the examples from Bondei (G24; Tanzania) in (13) and from Sukuma (F21; Tanzania) in (14).

- (13) *vund-i-a mwe-mnda*
 rot-APPL-FV 18-farm
 ‘rot in the farm’ (Bondei; Rugemalira 2004:287,(35))

- (14) *ful-il-a mu-mongo*
 wash-APPL-FV 18-river
 ‘wash (clothes) in the river’ (Sukuma; Rugemalira 2004:287,(33))

In the examples in (11) to (14), the locatives are complements either of an applicativized or non-applicativized verb. In other languages, however, it is claimed that the locative prefixes function more like prepositions (Welmers 1973). For the current discussion, the crucial question is the synchronic status of locative-marked phrases in Kinyarwanda.

I argue that locative-marked phrases in Kinyarwanda are arguments of the verbs with which they appear, though they are often optional. The following diagnostics suggest an analysis of locative phrases as arguments: locative phrases are permitted in argument positions such as the subject of a passive, and, like arguments, they may trigger agreement (both subject agreement or as an object marker). Furthermore, locatives cannot be productively used with all non-applicativized verbs, with many verbs instead requiring an applicative to license the locative.

The first piece of evidence that locative-marked phrases are arguments is that locative-marked phrases can appear in argument positions, such as the subject of a passive verb. In addition, when they appear in this position, they trigger subject agreement with the main

verb. Consider the example in (15), where the locative phrase is the subject of a passive and triggers subject agreement. Note that in Kinyarwanda, all locative classes (i.e. classes 16, 17, 18, and 23) trigger class 16 agreement morphology.⁷ Crucially, note that the subject marker does not agree with the class 5 head noun *mw'ishyamba* 'forest', but rather the class 18 locative prefix *mu*.⁸

- (15) *Mw' i-shyamba h-a-tem-e-w-e* *igi-ti n' umu-higi.*
 18 5-forest 16S-PST-cut-APPL-PASS-PERF 7-tree by 1-hunter
 'In the forest was cut the tree by the hunter.'

In this example, the applied locative object is in subject position and triggers subject agreement on the verb.

Further evidence for the analysis of locatives as arguments is that a locative object may be object marked on the verbal stem. For example, in (16) a previously mentioned locative phrase, such as *mu nzu* 'in the house', may be replaced with the class 16 object marker *-ha*.

- (16) *N-a-ha-bon-ey-e* *umw-ana.*
 1sS-PST-16O-see-APPL-PERF 1-child
 'I saw the child there.'

In the examples in (15) and (16), the applicative morpheme is used to license the locative, though it is not in fact always necessary for the applicative to license locative objects. Unlike languages like Bondei in (13) and Sukuma in (14) above, it is possible in Kinyarwanda to have locative phrase in situations where there is no applicative. At a first glance, the fact that the locative is permitted without licensing via the applicative, as in (17), suggests that locative phrases can also be adjuncts.

- (17) *N-a-bon-ye* *umw-ana mw' i-shyamba.*
 1SGS-PST-see-PERF 1-child 18 5-forest
 'I saw the child in the forest.'

⁷The use of the class 16 subject agreement marker is in fact a frequent pattern in various Bantu languages, especially among languages in East Africa (Maho 1999, Batibo 1985).

⁸In standard Kinyarwanda orthography, the locatives are written separately. I retain this convention here, but assume grammatically the locative is affixed to the noun.

However, I argue that these are in fact arguments of verbs that occur with them, and specifically pattern essentially like objects. First, consider the data in (18) and (19), which present parallel data to that in (15) and (16) but without the locative applicative.⁹

(18) *Mw' i-shyamba h-a-bon-w-e-mo umw-ana.*
 18 5-forest 16S-PST-see-PASS-PERF-18O 1-child
 'In the forest was found/seen a child.'

(19) *N-a-ha-bon-ye umw-ana.*
 1SGS-PST-16O-see-PERF 1-child
 'I saw the child there.'

Furthermore, it is not the case that a locative phrase can productively appear with any verb. For example, in (20) it is not possible to combine a locative with the verb *ku-vuga* 'to talk' without the use of an applicative.

(20) *Habimana a-ri ku-vug-*(ir)-a mu n-zu.*
 Habimana 1S-BE INF-talk-APPL-IMP 18 9-house
 'Habimana is talking in the house.'

In (20), the use of the applicative is obligatory in order to license the locative *mu nzu* 'in the house' with the verb *ku-vuga* 'to talk'. I take the fact that the locative is only permitted without the applicative with certain verbs, as well as the fact that when it does occur, it behaves like a direct object, to be evidence that the locative is an optional argument of those verbs which allow a locative phrase in their non-applied form.¹⁰

Finally, the last piece of evidence for the analysis of locatives as arguments is that the number of locatives permitted within a single clause is restricted. Consider the following examples, where there are two locative phrases. If locatives are able to pattern as adjuncts, it should be possible that the second locative can be added into the phrase; the data in (21)

⁹The use of a locative applicative with these examples affects the reading of the sentence. With the applicative, both the subject and the object are considered to be in the location described by the locative, while without the applicative only the object is located at the specified location. See Cann & Mabugu (2007) for a discussion of a similar effect in Chishona. I set this distinction aside in the present study.

¹⁰I leave the larger question of *why* particular verbs would have a locative argument and not others open for future research.

and (22), however, show that this is not the case. While one locative is permissible in the (a) sentences, an additional locative is ruled out in the (b) sentences.

- (21) a. *Nkusi a-ri kw-ambuka mu n-yanja*
 Nkusi 1S-COP INF-cross 18 9-ocean
 ‘Nkusi is crossing the ocean.’
- b. **Nkusi a-ri kw-ambuka mu n-yanja i Mombasa.*
 Nkusi 1S-COP INF-cross 18 9-ocean 23 Mombasa
 Intended: ‘Nkusi is crossing the ocean at Mombasa.’
- (22) a. *Nkusi a-ri kw-injira mu n-zu.*
 Nkusi 1S-COP INF-enter 18 9-house
 ‘Nkusi is entering the house.’
- b. **Nkusi a-ri kw-injira mu mu-ryango mu n-zu.*
 Nkusi 1S-COP INF-enter 18 3-door 18 9-house
 Intended: ‘Nkusi is entering the door at the house.’

In (21) and (22), the number of locative phrases is restricted, though note that this is not a semantic or pragmatic issue: there is nothing contradictory or pragmatically odd in increasing the number of locative phrases in this way, from which I conclude that the restriction on the number of locative phrases is a syntactic restriction on the number of arguments. This provides further evidence that locatives are not adjuncts in Kinyarwanda since adjuncts in principle are not syntactically limited.

While a fuller exposition of the grammatical nature of locative phrases in Kinyarwanda (and in Bantu more broadly) is left for future research, from the evidence presented above, I assume here that the applied locative phrases in Kinyarwanda are (optional) object DP arguments of the verb (either of the base verb or via the applicative) for the rest of this chapter.¹¹ In cases where a locative object is present as an argument of the non-applied verb, I propose that the applicative in fact has the effect of preserving an argument of the

¹¹I leave open the possibility that there could in principle exist PP arguments, and I make no claims for the behavior of these phrases in other languages. But for what follows, I assume any locative phrase is a DP in Kinyarwanda.

verb instead of licensing an additional one, though, as I show in detail below, there will be a change in the semantics with the applied variant.

2.3 Post-Verbal Locative Clitics

The last grammatical form I discuss in this section is the class of post-verbal locative clitics *-ho*, *-yo* and *-m(w)o*, which have cognates in various languages. As with the other locative forms, there is considerable variation in the behavior in these clitics across languages. As mentioned at the beginning of the section, in the dialect of Alexander Kimenyi, these are applicatives, while in Chicheŵa, the cognate morphemes have a semantic use and convey that the theme is permanently located at the location in question (Simango 2012). Consider the following data from Chicheŵa, where the sentence in (23a) is unspecified as to what is located by the locative *pa-mpando* ‘on the chair’; the example in (23b), however, unambiguously means that the letter was written into the chair, i.e. the message was inscribed on the chair.

- (23) a. *Thoko a-na-lembe-a kalata pa-mpando.*
Thoko 1S-PST-write-FV 9.letter 16-chair
‘Thoko wrote a letter on the chair.
- b. *Thoko a-na-lembe-a-po kalata pa-mpando.*
Thoko 1S-PST-write-FV-16.LOC 9.letter 16-chair
‘Thoko wrote a letter on the chair. (Chicheŵa; Simango 2012:145,(14a-b))

Simango analyzes the locative clitic in Chicheŵa as a means of indicating the location of the theme specifically, and the reading that arises is contingent upon the meaning of the verb.

In various other languages such as Runyambo, a locative clitic can only be used to replace a full locative phrase (Rugemalira 2004), as in (24).¹²

¹²In Lubukusu, locative clitics are used in a similar way, but with interesting effects on agreement and extraction which I do not discuss here (Diercks 2011).

- (24) a. *taaha-mu*
 enter-18.LOC
 ‘enter in there’
- b. *reeba-yo*
 look-LOC
 ‘look over there’ (Runyambo; Rugemalira 2004:289,(66-67))

In Kinyarwanda, like Runyambo, the locative clitics are in complementary distribution with the full locative phrase and, like pronouns, they are used to refer back to a previously discussed location. For example, with a locative licensed by the applicative, such as the applied variant of *ku-vuga* ‘to talk’ in (25), the locative clitic can replace the full locative phrase.

- (25) *Habimana a-ri ku-vug-ir-a(=mo/yo).*
 Habimana 1S-BE INF-talk-APPL-IMP=LOC
 ‘Habimana is talking there.’

The use of a particular locative clitic is contingent upon context; in the example in (25), the use of =*mo* indicates that the subject *Habimana* is speaking inside of the location (e.g. his house), while the use of =*yo* indicates that he is speaking at a more general location (e.g. a park).¹³ While the locative clitic does not figure prominently into the current discussion, it is important to reiterate that for the Kinyarwanda speakers who were interviewed for this project, these forms are not applicatives, but rather anaphoric locative clitics that replace a locative argument in the clause. Furthermore, these clitics are only possible when the verb selects a locative argument.

2.4 Interim Summary

In this section, I have outlined the variation in three different grammatical forms for indicating a location in Bantu languages, with the goal of situating Kinyarwanda into the typology

¹³The clitic =*ho* is also permissible with the applied variant of *ku-vuga* ‘to talk’, but it does not have a literal locational interpretation. Instead, the use of =*ho* indicates that the subject *Habimana* is using something to talk, such as his cellphone. Note that these three clitics correspond to the class 17, 19, and 23 locative class prefixes.

of locative forms. Specifically, I discussed the locative applicative, the locative clitic, and the locative class prefix. While the locative applicative may add a wholesale new locative DP object, data from languages like Setswana suggest that other locative roles may appear in certain cases, and I explore this point in Kinyarwanda in the next section. I also argued that locative DPs are object arguments in Kinyarwanda: they appear in argument positions like the subject of a passive or as an object-marker, they are restricted to specific verbs, and there is a limit to the number of locatives that may appear in a particular sentence. Kinyarwanda also has a class of locative clitics, which behave like pronouns (in the dialect under discussion), replacing previously discussed locative information.

In the next section I show that the semantic role of the locative applied object varies depending on the semantic class of the verb to which the applicative attaches. Then, in §4, I outline a formal analysis that captures the array of uses of the locative applicative in Kinyarwanda.

3 Verbs Classes and Locative Applicatives

In the previous section it was shown that there is cross-linguistic variation in the realization of locatives across the Bantu family. In addition to variation across languages, there is also variation within specific languages with respect to the syntactic realization of locative phrases as well as the semantic role that is assigned to the object. Crucially, this variation corresponds to the class of verb to which the applicative attaches, as shown in detail by Rugemalira (1993) for Runyambo (JE21; Tanzania). In this section I show that the semantics of verb class correlates with the semantic role of the applied object of locative applicatives in Kinyarwanda. The effect of verb class argument realization in Bantu has been almost completely ignored, and I make the case here and in the following section that in fact the semantics of the verb is crucial to capturing the behavior of applicatives.

Before addressing the effect of verb class in Kinyarwanda, I first discuss Rugemalira

(1993), who is perhaps the only work that has considered the importance of verb class in argument realization. Rugemalira describes a four-way typology of locative phrases in Runyambo, which is determined by the use of a locative applicative as well as whether the locative object requires a locative prefix: (i) verbs which require the applicative to license a locative DP, which must be marked with a locative prefix, (ii) verbs that disallow the applicative and require the locative prefix on the locative DP, (iii) verbs where the presence of the applicative changes the interpretation of the locative-marked DP object, and (iv) verbs which take a locative-marked DP without the applicative and an unmarked DP with the applicative. Examples of these patterns are given in (26) – (29), respectively. Note that in all cases, the locative prefix is obligatory on the DP except for the final case in (29) where the locative prefix is obligatorily absent when the applicative is used.

- (26) a. *gamb-ir-á omu-nju*
 speak-APPL-FV LOC-house
 ‘to speak in the house’
- b. **gamb-a omu-nju*
 speak-FV LOC-house
- (27) a. *a-ka-mu-sang-á omu-nju*
 1S-PST-1O-find-FV LOC-house
 ‘he found her in the house’
- b. **a-ka-mu-sanj-ir-á omu-nju.*
 1S-PST-1O-find-APPL-FV LOC-house
- (28) a. *biik-á omu-nju*
 store-FV LOC-house
 ‘store (something) in the house’
- b. *biic-ir-á omu-nju*
 store-APPL-FV LOC-house
 ‘store (something) while in the house’

- (29) a. *sitam-á aha-ntébe*
 sit-FV LOC-chair
 ‘sit on a chair’
- b. *sitam-ir-á entébe*
 sit-APPL-FV chair
 ‘sit on a chair’ (Runayambo; Rugemalira 1993:71-72,(331-334))

The classes differ as to whether the applicative morpheme or the locative prefix on the locative (or both) is needed to license a locative argument. The most common pattern among the 530 verbs he considers is the pattern in (26) in which both the applicative and locative prefix are present (378 verbs or 71% of the data). The next most common pattern is that where the applicative is optional and its use changes the meaning of the location (108 verbs; 20% of the data). Only 28 verbs have the third most common pattern in which the applicative is disallowed. The least common class is that where the applicative and locative prefix are in complementary distribution (16 verbs; 3% of the data).

It is important to highlight that Rugemalira’s fourth pattern — where the applicative and a locative prefix are in complementary distribution — is the use that has dominated research on applicatives; in other words, previous approaches have assumed that the function of an applicative is to license a full object of the verb, which, on many analyses, alternates with an oblique-marked adjunct role (e.g. Perlmutter & Postal 1983 treat applicativization as a promotion operation which promotes the oblique locative to a core locative object).¹⁴ However, this use of the locative applicative accounts for only 3% of the verbs in Rugemalira’s sample. This, in conjunction with the various uses of the locative described throughout the next section, suggests that the literature has not captured the full breadth of uses of applicative morphology.

Rugemalira’s finding is that the syntactic realization of locative expressions is conditioned by the verb, and whether the applicative is optional, obligatory, or disallowed is

¹⁴This proceeds on the assumption that the locative prefix is an oblique marker. It is not clear what the status of the locative prefix is in Runyambo.

also contingent on the verb, though exactly why is an open question. For Rugemalira, he groups verbs into four syntactic classes, assuming that the syntactic variation in the selection of locatives is idiosyncratic to verbs within this class. However, unlike the present study, Rugemalira rejects the notion that there are semantically-defined verb classes such as “motion verbs,” instead focusing on their syntactic behavior. For what follows, I take as central the perspective that argument realization patterns are constrained by verb meaning, and furthermore, I show that the semantic role of the applied object is conditioned by the semantic verb class of the verb to which the applicative attaches.

3.1 The Typology of Locative Applicatives in Kinyarwanda

In this section I outline a further empirical point that is unanalyzed on the traditional view: the thematic role of the applied object is often conditioned by the meaning of the verb to which it attaches. I describe four locative meanings that are added to different kinds of motion verbs via applicativization: general location, goal, route, and source. Specifically, manner of motion verbs have a goal applied object, traversal verbs have a source applied object, change-of-location verbs (i.e. path verbs) have a route applied object, and non-motion verbs take a general location applied object. Crucially, these four roles are particular to the class of verb, and these verb classes have been shown to be grammatically relevant classes in previous literature (Talmy 1975, Slobin 1996, Zlatev & Yangklang 2004, Beavers et al. 2010, Bassa Vanrell 2013).

In the following discussion, I assume an analysis of motion where a complete motion event involves a *figure* moving from a *source*, along a *route*, and ending at a *goal*, and the source, route, and goal collectively define the *path* of the motion. Of course, a motion predicate describing such an event need not overtly express all of these elements simultaneously, and — as I show below — different verbs in Kinyarwanda categorize syntactically and/or semantically for different parts of the motion event even if in principle all components

must exist as part of any specific motion event. Rather, each of the possible components of motion (source, route, or goal) is brought out by a specific verb type.

The first category of verbs under discussion are verbs where the applicative adds a general location, i.e. the specific location where the event took place.

- (30) a. *Mukamana a-ri ku-vug-a* (**mu n-zu*).
 Mukamana 1S-BE INF-talk-IMP 18 9-house
 ‘Mukamana is talking.’
- b. *Mukamana a-ri ku-vug-ir-a mu n-zu*.
 Mukamana 1S-BE INF-talk-APPL-IMP 18 9-house
 ‘Mukamana is talking in the house.’

In (30a), the verb *ku-vuga* ‘to talk’ is intransitive, while in (30b), there is a new locative phrase, licensed by the applicative morpheme, indicating the location of the talking event. This is the default case that applies to non-motion verbs in Kinyarwanda, such as *gu-shaka* ‘want/search’, *gu-teka* ‘to cook’, *ku-rya* ‘to eat’, and *ku-nywa* ‘to drink’. Crucially, none of these verbs licenses a locative argument in their non-applied uses, and the applicative is obligatory to license the locative phrase.

The second type is a verb where the applicative adds a goal to the event described by the verb, as occurs with manner-of-motion verbs, i.e. verbs which describe a particular kind of physical motion of the figure without specifying the exact goal of the motion, such as *kw-iruka* ‘run’, *gu-tembera* ‘to go about’, and *gu-simbuka* ‘to jump’.

- (31) a. *Mukamana a-ri kw-iruk-a*.
 Mukamana 1S-BE INF-run-IMP
 ‘Mukamana is running.’
- b. *Mukamana a-ri kw-iruk-ir-a kw’ isoko*.
 Mukamana 1S-BE INF-run-APPL-IMP 17 market
 ‘Mukamana is running to the market.’

In (31b), the new location licensed by the applicative is not a general description of where the event took place (i.e. it cannot be interpreted as “Mukamana ran inside the market”),

but rather the goal of the running event. For many of these verbs, it is also possible to have a locative object without the applicative (something which I return to below). For a subgroup of this class, namely positional verbs, such as *kw-icara* ‘to sit’ and *ku-ryama* ‘lie down’, the applied object describes what I informally refer to as a “sub-location” — some small item that is positioned beneath the subject, much like a goal.

- (32) a. *N-icay-e mu bitaro.*
 1SG-sit-PERF 18 hospital
 ‘I sat in the hospital.’
- b. *N-icar-iy-e terefoni.*
 1SG-sit-APPL-PERF telephone
 ‘I sat on the telephone.’

In (32b), the applied predicate describes not a general location, but rather some small object that is being sat upon.¹⁵ I assume that these cases are similar to the case of manner of motion verbs such as *kw-iruka* ‘to run’, but with *ku-ryama* ‘to lie down’ and *kw-icara* ‘to sit’, the goal is highly specific to be the place that is sat or laid upon. Additionally, speakers comment that in these cases, the item that is sat upon is often accidental; the subject in (32) did not intend to sit down on the telephone.

Third, the applied object may encode the route of the event, as in (33), with so-called path verbs, i.e. verbs which describe a change of location via movement along a route without specifying the manner of motion. This class includes verbs such as *kw-injira* ‘to enter’, *gu-sohoka* ‘exit’, *ku-manuka* ‘descend’, *kuzamoka* ‘ascend’, and *ku-rira* ‘to climb’.

- (33) a. *N-di kw-injir-a mu n-zu.*
 1SG-BE INF-enter-IMP 18 9-house
 ‘I am entering the house.’
- b. *N-di kw-injir-ir-a mu mu-ryango (mu n-zu).*
 1SG-BE INF-enter-APPL-IMP 18 3-door 18 9-house
 ‘I am entering the house through the door.’

¹⁵Recall that perfective morphology in Kinyarwanda often has phonological ramifications for the verb stem. Here, the root for *kw-icara* ‘sit’ changes to *-caye* in the perfective.

Verb Type	Applied Object Meaning	Example
manner of motion	goal	<i>kw-iruka</i> ‘to run’
path	route	<i>kw-injira</i> ‘to enter’
traversal object	source	<i>kw-ambuka</i> ‘to cross’
non-motion	general location	<i>ku-vuga</i> ‘to talk’

Table 7: Verb classes and corresponding applied object meaning

Here, the applied object describes the route via which the motion event occurs. Note that the applicative is obligatory to license any additional arguments beyond the goal in (33), cf. (22) in §2.2. Note that the goal argument can be omitted; I return to this below in §4.3.

Finally, there are verbs where the locative applied object is the source of the event, as with the traversal object verb *kw-ambuka* ‘to cross’, which describes motion across some route. For these verbs, the applied object in (34b) is the source of the crossing event.¹⁶

- (34) a. *Y-∅-ambuts-e* (mu) *n-yanja*.
1S-PST-CROSS-PERF 18 9-ocean
‘He crossed the ocean.’
- b. *Y-∅-ambuk-iy-e* (mu) *n-yanja i Mombasa*.
1S-PST-CROSS-APPL-PERF 18 9-ocean 23 Mombasa
‘He crossed the ocean from Mombasa.’

The example of the non-applied verb *kw-ambuka* ‘to cross’ in (34a) shows that the thematic object of the verb is the route through which the event took place, such as an ocean. In (34b), the applied object is interpreted as a source of the crossing event. In this example, the subject is crossing the ocean (e.g. by boat) and started the voyage in Mombasa. As with path verbs, the applicative is obligatory in licensing any objects in addition to the route, cp. (21). Table 7 summarizes the various semantic roles that appear on the applied object of the different verbs that were discussed in this section.

¹⁶The verb *kw-ambuka* ‘to cross’ is the only example to date that I have encountered which describes this kind of motion.

4 Analyzing the Kinyarwanda Locative Applicative

The previous two sections have argued that the meaning of a locative applied object is contingent upon the meaning of the verb and its internal arguments. The traditional analysis of applicatives assumes that an applicative morpheme adds a new object to the argument structure of the verb, and this object is assigned one of a limited set of thematic roles. It was shown in Chapter 1 and at points in the previous two sections that two broad empirical points problematize this view: (1) the range of roles available for assignment to the applied object is contingent upon the class of the verb to which the applicative attaches, and (2) the applicative does not always add a new object.

4.1 Applicativization as a Semantic Constraint

In order to capture these facts, I instead analyze applicativization in terms of satisfying a paradigmatic semantic constraint on the kind of meaning that an applied and non-applied variant of a single verb form can have relative to one another. This is comparable to earlier work which has proposed paradigmatic constraints of this sort with argument alternations (Ackerman & Moore 2001, Beavers 2010). Specifically, I propose an output condition on applied verb meanings where the applied predicate has a monotonically stronger set of truth conditions pertaining to an internal argument than the corresponding non-applied variant.¹⁷ This constraint is stated as the Applicativization Output Condition (AOC) in (35):

- (35) **Applicativization Output Condition:** In alternations between applied and non-applied forms of a verb, the applied variant has at least one internal argument, and the truth conditions associated with that internal argument by the predicate projected by the applied verb are a strict superset of those associated with it by the predicate projected by the non-applied variant.

¹⁷By “monotonic” I mean that a new meaning is added without removing any prior meaning in the base predicate (Koontz-Garboden 2007, 2012).

The AOC is an intentionally vague constraint, but it makes predictions about possible analyses, namely it predicts that there will always have more meaning in the applied variant than in the non-applied variant of a given verb. This rules out any non-applied variant having a stronger meaning than an applied variant. Otherwise it encompasses a range of possible actual types of applicativization, which I suggests vary along two dimensions: first is what the syntactic and semantic relationship is between the applied and non-applied variants, and the second is what kind of operation relates the two variants together. I discuss each in turn in the following two subsections.

4.2 Possible Paradigms

I turn first to showing how the AOC captures paradigmatic relations between applied/non-applied verb pairs in Kinyarwanda, with the focus mostly on the locative applicative. Note that one benefit of the AOC is that it does not technically require that applicativization categorically adds a new internal argument (though this is certainly a possibility). In what follows, I show in fact that there are three additional ways to satisfy the AOC which exhaust the logical possibilities that arise given what arguments are syntactically and/or semantically selected for by the non-applied verb.

The first two types are the kinds that have already been suggested in the literature, either in Bantu directly or for other languages. The first case is the traditional view, where there is addition of a wholesale new participant in the event both syntactically and semantically, as with non-motion verbs like *ku-vuga* ‘to talk’. Here, the AOC is satisfied in that there is a wholesale new participant in the meaning of the verb and a new internal argument, resulting in the applied variant having a stronger set of truth conditions associated with some internal argument not present in the non-applied variant due to its lack of that argument altogether. The second case is where there is no addition of a syntactic argument but instead the applied variant increases the content associated with an already extant internal argument, a

perspective that has been taken in analyzing certain classes of argument alternations in English (Beavers 2010, Ackerman & Moore 2001). This is the use with *gu-tera* ‘to throw’, as mentioned in Chapter 1.

However, there are two other logical possibilities for satisfying the AOC. In particular, it could be that the argument constrained by the applicative is not in the verb’s predicate argument structure, but is nonetheless an implicit semantic argument of the verb qua being a participant the verb entails to be part of the event, despite not being taken as an argument syntactically. In this case, the applicative could give syntactic license to an otherwise semantically implicit participant thus contributing additional information about this participant — either in terms of new thematic information or at least minimally, as will be the case below, new information about the referent of the participant that otherwise is not there if it is left implicit. This again results in the predicate projected by the applied variant making a stronger claim about an internal argument than the one projected by the non-applied variant. This is the use I claim is found with most motion verbs, as discussed in §3.

On the same token, the opposite case could hold: the applied variant could give semantic content to an existent internal argument of the non-applied variant that entirely lacks any thematic role but is nonetheless syntactically present, i.e. the applicative adds meaning to a syntactic argument that is not a semantic argument of the base verb. However, this fourth option is ruled out since I assume it is not possible for a verb to have a syntactic argument without any corresponding semantic argument (save perhaps for expletives or raising constructions, but these are not relevant here). Thus there are three available ways of satisfying the AOC, and I show that all three are borne out in Kinyarwanda. Table 8 outlines the typology of possible base verbs and the different effect the applicative has in each case. The first two columns indicate whether the relevant internal argument is licensed as a syntactic (Column 1) or semantic (Column 2) argument of the non-applied variant. The corresponding effect of the applicative is listed, with the presence/absence of an argument

Relation of AO to Non-Applied Verb		Effect of Applicative	Example
<i>Syntactic Arg.</i>	<i>Semantic Arg.</i>		
no	no	new argument and role	non-motion verbs
no	yes	license sem participant	motion verbs
yes	yes	modify thematic role	<i>gu-tera</i> ‘to throw’
yes	no	not possible	n/a

Table 8: Contribution of Applicative with Different Non-Applied Base Verbs

in the syntactic or semantics affecting how a given applied verb satisfies the AOC.

This analysis takes as inspiration an idea put forth by Beavers (2010), who, building on work by Dowty (1989, 1991a) and Ackerman & Moore (2001), shows that in direct/oblique alternations in English, the direct object realization of the alternating argument has as strong or stronger truth conditions than the oblique realization. For example, by adopting the analysis of affectedness in Beavers (2011b), he shows that various classes of verbs indicate different minimal contrasts in a hierarchy of affectedness in which the direct object realization has a stronger set of lexical entailments in the hierarchy than the oblique realization. Different predicates’ alternants lie at different points on this hierarchy, which provides a unified analysis of otherwise distinct types of alterations. With other alternating verbs, however, different scales may also be relevant for different grammatical functions. Here I adopt a related conception of this idea, extending Beavers’s analysis beyond argument alternations to encompass also putatively argument-adding operations, rather than just to alternations in how an already present argument is overtly realized.¹⁸

4.3 Productivity and Lexicalization

While verbs from different classes satisfy the AOC in different ways, there does appear to be cases of productivity within particular verb classes (comparable to the criteria-governed productivity in Pinker 1989; see also Dowty 1979, Chapter 6 for discussion of rule-governed

¹⁸Another difference is that in English, the two variants may have the same entailments; the restriction is just that if there is an alternant with stronger truth conditions, it is the direct-object realization. In the analysis I outline here, I assume that the truth conditions of the applied variant are always stronger than the non-applied variant.

lexicalization). There appear to be three degrees of productivity present with applicativization in Kinyarwanda: lexicalized cases (e.g. the verb *gu-tera* ‘to throw’), productivity within specific verb classes (e.g. manner of motion verbs), and generalized cases (e.g. non-motion verbs with locative applicatives). Furthermore, there appears to be a blocking relationship between applicativization at these three degrees of productivity, where the presence of a lexicalized use blocks the application of a more productive rule, and the possibility of a verb-class specific applicative blocks the more general applicativization process.¹⁹

Thus, there is a continuum of productivity between completely lexicalized paradigms and cases where the new meaning is productive (albeit perhaps productive within a particular class of verbs). It is probably not controversial to say that applicativization is productive, but it might be more so to say that some applicativization is lexicalized or restricted to just some verb classes. Thus before outlining my analysis, I provide two pieces of evidence in support of the view that lexicalization does in fact exist for particular applied/non-applied verb pairings: (1) the grammaticalization of presumed applicatives and (2) the non-productive use of unergative verbs with the benefactive applicative. First, there are many cases where the base verb appears to have a historical remnant of an applicative morpheme, despite now being analyzed as part of the stem synchronically. For example, verbs like *kw-injira* ‘to enter,’ *k-ohereza* ‘to send’, and *ku-rira* ‘to climb’ all have remnants of historical applicative morphemes, i.e. either *-ir* or *-er*, at the end of the stem, but before the final vowel.²⁰ Crucially, seemingly “applicative-like” phonological material in these cases is not productively added as an applicative in modern Kinyarwanda. For example, *kw-injira* is not derived from *kw-inja*, which instead means ‘to covertly gather information’. With *ku-*

¹⁹Another question which arises is *why* the constraint looks the way that it does. I assume that it relates to a question of iconicity; namely, the addition of morphological material (i.e. the applicative) corresponds to a greater number of lexical entailments.

²⁰Similar data is found in other Bantu languages. Consider for example the verb *ku-piga* ‘to hit’ in Swahili (G42; Kenya, Tanzania) which also has an idiomatic use to mean ‘to call’ with the applicative *i*.

(36) *Tom a-li-pig-i-a* *mama*.
 Tom 1S-PST-hit-APPL-FV mother
 ‘Tom called his mother.

rira ‘to climb’, there is no word *ku-ra* from which it is derived. Finally, with *k-ohezeza* ‘to send’, there is no related form *k-oheza*.²¹ Certain verbs, then, have a frozen meaning with some historically applicative morpheme, suggesting that the applicative is not productive.

Second, many verbs have idiosyncratic meanings when combined with an applicative. A noteworthy case is with unergative verbs with benefactive applicatives in Kinyarwanda, where the meaning of the applied verb is not predictable from the meaning of the base verb. While there is often distant conceptual relatedness between the forms, it is crucially not the case that the applied variant is transparently composed of the base verb plus a beneficiary meaning. For example, consider the unergative verbs *gu-seka* ‘to laugh’ and *kw-egura* ‘to resign’ in (37) and (38). When these verbs appear with the applicative the meaning is not predictable from the meaning of the base verb: *gu-sek-er-a* means to be fond or affectionate towards someone, while *kw-gur-ir-a* means to bequeath or donate something to someone.

- (37) a. *Karekezi a-ri gu-seka.*
 Karekezi 1S-COP INF-laughing
 ‘Karekezi is laughing.’
- b. *Karekezi a-ri gu-sek-er-a umw-ana.*
 Karekezi 1S-COP INF-laugh-APPL-IMP 1-child
 ‘Karekezi is fond of the child.’
- (38) a. *Ejo n-ar-eguy-e.*
 yesterday 1SGS-pst-RESIGN-PERF
 ‘I resigned yesterday.’
- b. *Ingabire y-a-bi-mw-egur-iy-e by-ose.*
 Ingabire 1S-PST-8O-1O-resign-APPL-PERF 8-all
 ‘Ingabire bequeathed everything to him.’

The data in (37) and (38) suggest that the applicative is not a productive operation that transparently derives an applied variant in all cases. In (37b), there is no literal laughing

²¹The verb *k-ohezeza* ‘to send’ is unique in the (productive) applicative is attached before the consonant ‘z’: *k-oh-er-er-eza* ‘send to/for’. This suggests that despite the fact that the frozen applicative on the verb was irregular in its place of attachment, given the placement of the frozen *-er* in the stem. Note also that there is a verb *gu-hera* ‘to hand’, which may originate from a similar stem to *k-ohezeza* ‘to send. I leave a full diachronic account of the origins of these verbs to future work.

taking place, and similarly, in (38b) there is no resignation; in both cases, the meaning of the applied variant is not predictable from the base verb. Instead, the meaning of the applied variant of a verb is lexicalized, though as I show below, there are often generalizations in the kinds of meanings that apply across verb classes even in cases where a given use of a given applicative is not fully productive.²²

It is worth noting that it is possible that languages vary with respect to how they satisfy the AOC. For example, it is permitted that a language does exist where the applicative morpheme always adds a new argument to the argument structure in the ways discussed in previous work (cf. the first line of Table 8). Similarly, while I do not pursue such facts here, this analysis can also be naturally extended to cases like the example in Chapter 1 from Swahili where the use of the applied variant indicates an addition in information structural content not present in the non-applied variant. In the next section, I show how the AOC captures the variation of the uses of applicatives in Kinyarwanda with respect to the meaning of the predicate by fleshing out the complete typology of possible ways of satisfying the AOC.

4.4 The Framework of Analysis

Formally, I implement the analysis notationally in terms of a typed lambda calculus. I assume a domain of discourse U that consists of two major sorts: the subset U_I of individuals and U_E of eventualities. In this chapter I do not discuss subevents, and all arguments here will be linked to a single event variable e .²³ I take a neo-Davidsonian approach in which thematic roles are binary relations relating individuals to events (Parsons 1990, Rothstein 2004). However, contra Kratzer (1996), I do not assume that subjects are licensed separately from the verb. I assume that a motion event is composed of a moving entity, or ‘figure’ that

²²In fact, to date, all unergatives I have elicited share this pattern of highly idiosyncratic meanings when the benefactive applicative is used. Perhaps there is something about the nature of unergativity that lends itself in particular to this idiosyncrasy. I leave this question for future research.

²³I do make use of causing events and changes of state in the next chapter.

travels along a series of locations, $l_1 \dots l_n$. The initial and final points in the sequence are defined as the *source* and *goal*, respectively. The *route* is the sequence of locations between the source and goal, but which includes neither the source nor goal.²⁴ *Source*, *goal*, and *route* are all thematic roles subsumed under a general thematic role *location*, abbreviated with *loc*.

The arguments of a given verb are listed in the verb's Predicate Argument Structure (PAS), which lists the syntactically realized arguments of a specific verb and, for expository purposes, subscripts the thematic role label of the argument. This notation does not conform to any specific formalism, but is easily translated into notions such as the θ -grid of a standard Principles-and-Parameters type approach, the ARG-ST of HPSG, or the a-structure of LFG. While most current Minimalist approaches license arguments with functional heads, I assume that the syntactic generalizations made here could be translated into argument-licensing heads.²⁵

The mapping between the denotation and the PAS is constrained by the order of composition. The final participant (i.e. the innermost lambda-abstracted individual) to be picked up is (as is generally assumed) mapped to subject, which is indicated with underlining in the PAS. In Chapter 4 I propose an argument reordering operation, but it does not apply in the cases discussed in this chapter. I assume that all other arguments are objects and are picked up in the order they appear after the verb on the PAS.²⁶ By means of example, consider the arguments for a lexically ditransitive verb. Such a verb would have three lambda-abstracted arguments in the semantic denotation and three corresponding arguments in the PAS, such

²⁴Asher & Sablayrolles (1995) distinguish between a *path* and a *strict internal path*, the latter being the path that contains no locations that overlap with the source or goal. For the present discussion, I use the term *route* to refer to what they define as *strict internal path*. In other vein of literature, it has been argued that a path prepositions selects for locative head in a layered PP van Riemsdijk (1990), Rooryck (1996), Koopman (2000), Svenonius (2007), van Riemsdijk & Huijbregts (2008). Similar to the present analysis, these works decompose complex motion events (see also Jackendoff 1990), though these analyses discuss languages with prepositions which contribute rich semantic meaning. In Kinyarwanda, and Bantu more generally, there is not this rich inventory of semantically-specific propositions.

²⁵In principle, this could be done by having a functional head which introduces each argument of the predicate and also introduces the meaning associated with that argument into the verb meaning compositionally.

²⁶Admittedly, this assumption is problematic for other Bantu languages, cf. the variation in objecthood in Chapter 5. However, for Kinyarwanda, the locative applied objects share the same properties as the thematic object, and so for the sake of argument I assume that all internal arguments in the PAS's discussed in this chapter are mapped to object.

as in (39) which shows the correspondences between the arguments in the PAS as the argument in the semantic denotation.

$$(39) \quad \begin{array}{ccc} \lambda x & \lambda y & \lambda z \quad [\quad . \quad . \quad . \quad] \\ & \diagdown & / \\ & \diagup & \diagdown \\ & & \end{array}$$

$$\langle \underline{DP}_{ag} \quad DP_{\alpha} \quad DP_{\beta} \rangle$$

In (39), the final argument z is the subject, as notated by the underlining of the first argument in the PAS. The other two arguments are mapped to object, with the first argument that is saturated in the semantics being the object immediately adjacent to the verb. Note that throughout, the subscripted thematic role labels in the PAS are purely expository. The arguments in (39) correspond to the ditransitive verb *gu-ha* ‘to give’ in (40).

$$(40) \quad \begin{array}{l} \textit{Karemera y-a-ha-ye} \quad \quad \quad \textit{Habimana igi-tabo.} \\ \textit{Karemera 1S-PST-give-PERF Habimana 7-book} \\ \text{‘Karemera gave Habimana the book.’} \end{array}$$

Consider now the denotations of the individual lexical items in (40) as defined in (41). The derivation in (42) explicitly shows how each of the arguments combines with the verb *gu-ha* ‘to give’.²⁷

$$(41) \quad \begin{array}{l} \text{a. } \llbracket \textit{guha} \rrbracket := \lambda x \lambda y \lambda z \lambda e [giving'(e) \wedge ag'(e, z) \wedge rec'(e, x) \wedge th'(e, y)] \\ \text{b. } \llbracket \textit{Karemera} \rrbracket := karemera' \\ \text{c. } \llbracket \textit{Habimana} \rrbracket := habimana' \\ \text{d. } \llbracket \textit{igitabo} \rrbracket := book' \end{array}$$

$$(42) \quad \begin{array}{l} \text{a. } \lambda x \lambda y \lambda z \lambda e [giving'(e) \wedge ag'(e, z) \wedge rec'(e, x) \wedge th'(e, y)] (\llbracket \textit{Habimana} \rrbracket) \\ \text{b. } \lambda z \lambda e [giving'(e) \wedge ag'(e, z) \wedge rec'(e, habimana') \wedge th'(e, y)] (\llbracket \textit{igitabo} \rrbracket) \\ \text{c. } \lambda z \lambda e [giving'(e) \wedge ag'(e, z) \wedge rec'(e, habimana') \wedge th'(e, book')] (\llbracket \textit{Karemera} \rrbracket) \\ \text{d. } \lambda e [giving'(e) \wedge ag'(e, karemera') \wedge rec'(e, habimana') \wedge th'(e, book')] \end{array}$$

²⁷I assume that the event variable is existentially bound at a higher node in the derivation.

$$e. \exists e[giving'(e) \wedge ag'(e, karemera') \wedge rec'(e, habimana') \wedge th'(e, book')]$$

In (42), the first argument to be composed with the meaning of the verb is *Habimana*, then *igitabo* ‘book’, and finally *Karemera*. By virtue of being the final participant picked up by the verb, it is this argument which is mapped to subject. With intransitive and transitive verbs, the mapping works in the same way, but with fewer arguments.

4.5 The General Case

The first example of applicativization I discuss is what I refer to as the general case: an applicative adds a new syntactic argument and corresponding semantic participant. This is the kind of applicative that is assumed on the traditional view of applicatives, where the function of the applicative is to monotonically add a locative object to the argument structure. Semantically, the applicative adds a locative participant to the meaning of the verb, which I represent formally in (43a) as a function that takes a predicate as an argument in addition to all the arguments and events associated with that predicate. In (43b), I show that there is an increase in the valency of the PAS when the applicative is used.²⁸

$$(43) \quad \text{a. } \llbracket -ir_{loc} \rrbracket = \lambda P \lambda l \lambda x_1 \dots \lambda x_n \lambda e [P(x_1 \dots x_n, e) \wedge loc'(e, l)]$$

$$\text{b. } \langle \underline{DP}_{ag} \dots \rangle \Rightarrow \langle \underline{DP}_{ag} \underline{DP}_{loc} \dots \rangle$$

The notation of $x_1 \dots x_n$ indicates that all of the arguments of the predicate to which the applicative attaches are preserved as well as, crucially, their ordering with respect to one another. The argument licensed by the locative in this case is the first argument to be saturated. I take this particular use of *-ir* to be relatively productive, though blocked in certain cases, such as the classes of verbs I discuss below.

I assume that the verbs which compose with the meaning in (43) are those which do not have any locative participant in their non-applied meaning. Such verbs include *gu-shaka*

²⁸Again, I technically leave open how the additional argument is licensed into the PAS, e.g. via a morpholexical operation or a functional head. The crucial point here is that the valence of the verb increases by one, and that the new argument is an internal argument.

‘want, search’ *gu-teka* ‘to cook’, *ku-rya* ‘to eat’, and *ku-nywa* ‘to drink’. Take, for example, the verb *ku-vuga* ‘to talk’, which has the denotation in (45).

(44) *Uwase a-ri ku-vug-a.*
 Uwase 1-BE INF-talk-IMP
 ‘Uwase is talking.’

(45) a. $\llbracket ku-vuga \rrbracket := \lambda x \lambda e. [talking'(e) \wedge ag'(e, x)]$
 b. $\langle \underline{DP}_{ag} \rangle$

In (45), there is one participant in the semantics which maps to the single syntactic argument of the verb as subject. In (46a), the meaning of the applicative in (43) composes with the meaning of the verb *ku-vuga* ‘to talk’ in (45), the result is the denotation in (46c). The new PAS is given in (46d). Here *n* in (43) is resolved to 1 since the input verb takes one individual argument.

(46) a. $\lambda P \lambda l \lambda x \lambda e [P(x, e) \wedge loc'(e, l)] (\lambda x \lambda e. [talking'(e) \wedge ag'(e, x)])$
 b. $\lambda l \lambda x \lambda e [\lambda x \lambda e [talking'(e) \wedge ag'(e, x)] (x, e) \wedge loc'(e, l)]$
 c. $\lambda l \lambda x \lambda e [talking'(e) \wedge ag'(e, x) \wedge loc'(e, l)]$
 d. $\langle \underline{DP}_{ag} DP_{loc} \rangle$

The composition of the verb and the applicative in (46a) reduces to the denotation in (46c), where in addition to the single argument of the verb (i.e. *x*), there is also the locative argument added by the locative applicative (i.e. *l*). There is also an additional locative phrase in the PAS, corresponding to the argument that is added by the applicative. The agent is mapped to subject, as it is the last argument to be picked up. Notationally, I mark the locative with DP_{loc} in the PAS for clarity, though recall that it is the order of composition which determines the mapping of arguments. Consider the derivation in (49) of the sentence in (47). The meaning of the applied verb is that in (46b), while the meanings of the NPs in the sentence are provided in (48).

(47) *Uwase a-ri ku-vug-ir-a mu n-zu.*
 Uwase 1S-BE INF-talk-APPL-IMP 18 9-house
 ‘Uwase is talking in the house.’

(48) a. $\llbracket Uwase \rrbracket := uwase'$

b. $\llbracket munzu \rrbracket := house'$

(49) a. $\lambda l \lambda x \lambda e [talking'(e) \wedge ag'(e, x) \wedge loc'(e, l)](\llbracket munzu \rrbracket)$

b. $\lambda x \lambda e [talking'(e) \wedge ag'(e, x) \wedge loc'(e, house')](\llbracket Uwase \rrbracket)$

c. $\lambda e [talking'(e) \wedge ag'(e, uwase') \wedge loc'(e, house')]$

d. $\exists e [talking'(e) \wedge ag'(e, uwase') \wedge loc'(e, house')]$

The denotation in (49d) states that there is a talking event with an agent and a location participants. The agent is mapped to subject, while the locative is mapped to object. This verbal paradigm satisfies the AOC in (35) in that there is a locative participant that is absent in the non-applied alternant of the verb, which is an increase in the truth-conditional content of the overall predicate.

4.6 Motion Verbs

Recall from §3 that there is variation among motion verbs with respect to the semantic role of the applied object, and depending on the verb, the applied object is either a source, a route, or a goal. Specifically, these three semantic roles are found with traversal verbs, change-of-location verbs (or “path verbs”), and manner-of-motion verbs, respectively, as repeated for convenience from §3 in (50), (51), and (52).

(50) a. *Karemera y-∅-ambuts-e in-yanja.*
 Karemera 1S-PST-cross-PERF 9-ocean
 ‘Karemera crossed the ocean.’

b. *Karemera y-∅-ambuk-iy-e i Mombasa (mu) n-yanja.*
 Karemera 1S-PST-cross-APPL-PERF 23 Mombasa 18 9-ocean
 ‘Karemera crossed the ocean from Mombasa.’

- (51) a. *Uwase a-ri kw-injir-a mu n-zu.*
 Uwase 1-BE INF-enter-IMP 18 9-house
 ‘Uwase is entering the house.’
- b. *Uwase a-ri kw-injir-ir-a mu muryango (?mu n-zu).*
 Uwase 1-BE INF-enter-APPL-IMP 18 door 18 house
 ‘Uwase entered (the house) through the door.’
- (52) a. *Habimana y-a-simbutse mu ma-zi.*
 Habimana 1-PST-jump-PERF 18 6-water
 ‘Habimana jumped into the water’ or ‘Habimana jumped while in the water.’
- b. *Habimana y-a-simbuk-iy-e mu ma-zi.*
 Habimana 1-PST-jump-APPL-PERF 18 6-water
 ‘Habimana jumped into the water.’

Before I continue, an important preliminary point I want to make is that the fact that these three verb classes behave differently in their argument realization properties is not surprising: exactly these three classes of verb meanings are cross-linguistically attested in prior literature to have distinct syntactic behavior both from each other and from non-motion verbs. In particular, manner of motion verbs and path verbs are known from work in the Talmy-typology to differ in whether and how they occur with dependents that explicitly encode the goal of motion. While path verbs (when they occur in a given language at all) consistently allow such dependents, manner of motion verbs only allow them in some languages and not others.

For example, in both English and French, path verbs permit a goal DP, such as the verb *enter* in English in (53) and *entrer* ‘to enter’ in French in (54).

(53) I entered the house.

(54) *Je suis entré dans la maison.*

I am entered in the house

‘I entered the house.’

(French; Beavers et al 2010:3,(1b))

The languages differ, however, in whether they permit a goal phrase with a manner of motion verb such as *limp* in English and *boiter* ‘to limp’ in French.’

(55) I limped to the store.

(56)??*J' ai boité à la librairie.*

I have limped to the bookstore

'I limped to the bookstore.'

(French; Beavers et al 2010:11,(17b))

The pattern is that in languages like English, goal phrases are permitted with both path verbs and manner of motion verbs, while in languages like French, goal phrases are not permitted with manner of motion verbs, (cf. Talmy 1975, Slobin 1996, Zlatev & Yangklang 2004, Beavers et al. 2010, Bassa Vanrell 2013, *inter alia*) (note that this broad description is slightly oversimplified, and there is variation in whether manner of motion verbs permit goal phrases, even in a language like French; I return to this in §4.4.). Traversal object verbs are unique from either of the other two in that they pick out the whole path as an argument, which is a property unique to this class of verbs. Thus, given the cross-linguistic variation in how these different classes behave, it is not surprising that there is variation between the three classes in Kinyarwanda.

Nonetheless, what unites these verbs as a class distinct from non-motion verbs is that they all describe motion. As motion verbs, this means they have a path participant as part of their meaning, and of course having a path participant means that as part of their meaning there must therefore also be a goal, source, and route, i.e. all of the implicit participants that may ultimately be realized as an applied object under applicativization. I formalize this generalization via the meaning postulate in (57).

(57) $\forall e[\exists p[\textit{path}'(e, p)] \leftrightarrow \exists x\exists y\exists z[\textit{source}'(e, x) \wedge \textit{route}'(e, y) \wedge \textit{goal}'(e, z)]]$

The meaning postulate in (57) states that there is also a goal, source, and route of an event e iff there is a path in the event e . Not only are each of these participants entitled to exist in a directed motion event, but each of these semantic roles is a subtype of location (evidence grammatically by the fact that all four thematic roles share the same morphological marking in Kinyarwanda; see §2.2 for discussion), another meaning postulate I formalize in (58).

$$(58) \quad \forall x \forall e [[source'(e, x) \vee route'(e, x) \vee goal'(e, x)] \rightarrow loc'(e, x)]$$

What unifies the applicativization in each case in (50) – (52) is that the applied object is giving syntactic license to one of these implicit participants in the motion event, i.e. the function here is not so much to introduce a wholesale new participant but rather to realize one that is already part of the meaning of the verb. This therefore justifies that this use of the applicative is distinct from the one discussed in the previous section, but it is also not arbitrary why it occurs with these verbs and not others. Since the locative applicative licenses a locative participant, it is expected that this particular use would only occur with verbs which have locative arguments already part of their meanings.

However, why the verbs here should differ in the exact way that they do — goals for manner verbs, source for route verbs, and route for path verbs — is unfortunately something more of a mystery (though see §4.4 on some special properties of manner verbs), and at present I do not have a deeper explanation for why this should be the case. While I leave this question to future work, I do assume that it is a lexical fact about the different verb classes, supported by the fact that these classes are independently motivated cross-linguistically to have unique properties, and each verb class specifies which of its implicit arguments is the one to be realized by the use of the applicative.

In order to capture the variation in which semantic role is selected by different verbs, I assume that each verb class takes its “chosen” argument as a semantic argument in its non-applied meaning, but this argument has no syntactic realization in the PAS (see (62) below).²⁹ In the default case, there is a lexical rule that existentially binds off that argument prior to insertion into the syntax. This rule is formalized in (59), where the input has a series of individual participants and a series of subevents,³⁰ and the output existentially binds the first argument to be picked up. In the corresponding PAS in (59b), there is no difference

²⁹A parallel idea has been proposed in a different framework. For example, Pylkkänen (2008) proposes so-called non-voice bundling languages, where the head that licenses the causal argument and the head that introduces causal meaning are separate (see Chapter 4, §3 for a brief overview of this approach). See also Alexiadou et al. (2006), who also separate the semantic contribution of causation and the licensing of a causer argument to separate heads.

³⁰I discuss the need for various subevents in the next chapter, but these are not relevant here.

in the number of arguments. Recall that the final argument to be picked up (i.e. x_n) is the subject of the sentence.³¹

- (59) a. $\lambda x_1 \lambda x_2 \dots \lambda x_n \lambda e_1 \dots \lambda e_m [P(x_1 \dots x_n, e_1 \dots e_m)] \Rightarrow$
 $\lambda x_2 \dots \lambda x_n \lambda e_1 \dots \lambda e_m \exists x_1 [P(x_1 \dots x_n, e_1 \dots e_m)]$
 b. $\langle \underline{DP}_n DP_1 \dots DP_{n-1} \rangle \Rightarrow \langle \underline{DP}_n DP_1 \dots DP_{n-1} \rangle$

I take this to be a formal instantiation of a broader typological feature of Niger-Congo languages that verbs are restricted to only allowing one locative argument in the absence of other licensing operations, such as applicatives or serial verb constructions (Creissels 2006). I turn now to outlining how this analysis captures the data with traversal and path verbs (I leave aside manner-of-motion verbs for now, since they have additional unique properties. I return to these in the next subsection.)

Consider, for example, the denotation of the verb *kw-ambuka* ‘to cross’ in (60) in which it is stated that the verb has an agent, a source, and a route.

- (60) $[[kwambuka]] := \lambda z \lambda y \lambda x \lambda e \exists p [crossing'(e) \wedge ag'(e, x) \wedge$
 $route'(e, y) \wedge source'(e, z) \wedge path'(e, p)]$

- (61) $\langle \underline{DP}_{ag} DP_{loc} \rangle$

Here we have three open participants: the agent, route, and source. (However, given (57) the existence of all three components of the path are entailed to be present in the meaning though I do not represent the goal, as it is not relevant to this discussion.) Despite the number of semantic participants, there are only two argument DPs in the PAS. Thus this is a case where the existential binding rule must apply. The existential binding of the syntactically unlicensed argument results in the denotation in (62) via the rule in (59a), where the argument z associated with the source is existentially bound.

³¹Crucially, it is not the case that any one individual argument can be existentially bound, but rather it is specifically the *first* argument to be picked up that is existentially bound.

(62) $\lambda y \lambda x \lambda e \exists z \exists p [crossing'(e) \wedge ag'(e, x) \wedge route'(e, y) \wedge source'(e, z) \wedge path'(e, p)]$

(63) PAS: $\langle \underline{DP}_{ag} DP_{loc} \rangle$

The mapping then results in the agent being the subject and the route being the object, as in the standard non-applied use of the verb *kw-ambuka* ‘to cross’ in (64).

(64) *Karemera y-∅-ambuts-e in-yanja.*
 Karemera 1S-PST-cross-PERF 9-ocean
 ‘Karemera crossed the ocean.’

After the existential binding of the argument z , there are only two overtly realized syntactic arguments of the non-applied verb *kw-ambuka* ‘to cross’: the agent and the route.

However, I propose that in addition to the “canonical” use of the applicative in (43) there is an additional use instantiating another possible resolution of the AOC, as in (65), which is the meaning of the applicative that specifically composes with motion verbs.

(65) a. $[-ir_{loc}] := \lambda P \lambda x_1 \dots \lambda x_n \lambda e [P(x_1 \dots x_n, e) \wedge loc'(e, x_1)]$
 b. $\langle \underline{DP}_{ag} \dots \rangle \Rightarrow \langle \underline{DP}_{ag}, DP_{loc}, \dots \rangle$

The denotation in (65) is nearly identical to that in (43) except for one crucial difference: here, there is no additional semantic argument added by the locative. Instead, it states that the first argument of the predicate (i.e. x_1) is associated with the *loc* thematic role, which has a corresponding argument in the PAS. Thus the denotation in (65) will associate a participant that already has a source, route, or goal, depending on the verb, with a locative role. Because these more specific roles are subtypes of the locative role, by virtue of the meaning postulate in (58), no contradiction arises. Note that in this case, the denotation in (65) is productive, but restricted to the class of motion verbs.

With this framework in mind, consider cases in which the applicative in (65) combines with the meaning of a verb like *kw-ambuka* ‘to cross’. The result is the meaning in (66).

(66) $\lambda z \lambda y \lambda x \lambda e \exists p [crossing'(e) \wedge ag'(e, x) \wedge route'(e, y) \wedge source'(e, z) \wedge loc'(e, z) \wedge path'(e, p)]$

(67) PAS: $\langle \underline{DP}_{ag} DP_{loc} DP_{loc} \rangle$

This denotation has three arguments: an agent, a route, and a source. The participant linked to the source is also linked to the general location, which is licit, given (58). Correspondingly, there is also an additional locative argument in the PAS than with the base predicate above in (62b), where the limitation on the number of locative arguments made the source unrealizable with the non-applied verb. Consider, then, the applied use of the verb *kw-ambuka* ‘to cross’ in (68a).

(68) a. *Karemera y-∅-ambuk-iy-e i Mombasa (mu) n-yanja.*
 Karemera 1S-PST-cross-APPL-PERF 23 Mombasa 18 9-ocean
 ‘Karemera crossed the ocean from Mombasa.’

b. $\exists e \exists p [crossing'(e) \wedge ag'(e, karemera') \wedge route'(e, ocean') \wedge source'(e, mombasa') \wedge loc'(e, mombasa') \wedge path'(e, p)]$

In this case the applicative is used to bring out a participant of the verb that cannot be licensed by the non-applied verb due to independent syntactic constraints on the number of locative arguments that the verb can license. Note that the truth conditions associated with the sentence in (68a) are narrower than those in the sentence in (64). In (68a) there is an explicit source argument, whereas the source of the motion event is existentially bound in (64). By virtue of being explicitly licensed in the applied case in (68a), the truth conditions of the predicate projected by the applied variant of *kw-ambuka* ‘to cross’ are stricter than those of the non-applied variant, thus satisfying the AOC.

A possible counter to this analysis is that perhaps existential binding can be achieved by the use of certain overt quantifiers, and the presence of such quantifiers in the applied object position would result in the participant brought out by the applicative being interpreted as simply existentially bound in both the applied and non-applied variants, violating the AOC.

However, Kinyarwanda differs from a language like English in that there is no comparable form for what in English would be used to existentially quantify a location (i.e. *somewhere*). The closest equivalent in Kinyarwanda is to use the word *aha-ntu* ‘place’ to describe an unnamed place, as in (69), where *aha-ntu* ‘place’ is used in the position licensed by the locative applicative.

- (69) *Karekezi y-a-ambuk-iy-e* *in-yanja aha-ntu (n-zi).*
 Karekezi 1S-PST-cross-APPL-PERF 9-ocean 16-place 1SGS-know
 ‘Karekezi crossed the ocean from a place (that I know).’

While this is the closest equivalent to English *somewhere*, consultants described that there is still a notion of specificity to the place being named, in fact preferring to say instead *aha-ntu n-zi* ‘a place that I know’ or some other phrase that qualifies the specific location of the event. I take this as evidence that with the locative applicative on a verb like *kw-ambuka* ‘to cross’, the locative introduces some specified location, even if that location is not named. I assume that this is a narrower claim than that made in the non-applied variant, which does not specify any particular source, but rather only that one exists, and thus this use of the applicative satisfies the AOC.

A related issue comes from the use of locative pronouns (or, in the case of Kinyarwanda, the locative clitic). Here, too, it could be argued that the use of a pronoun for the location licensed by the locative applicative may also be comparable to the non-applied predicate where the source is existentially bound. Consider, for example, the sentence in (70), where the source locative licensed by the applicative is marked by the locative clitic *-yo*.

- (70) *Karekezi y-∅-ambuk-iy-e=yo* *in-yanja.*
 Karekezi 1S-PST-cross-APPL-PERF=LOC.23 9-ocean
 ‘Karekezi crossed the ocean from there (e.g. Mombasa).’

Crucially, the use of the pronominal locative clitic is only permissible in a context where the referent of the pronoun is established from context, e.g. in a situation where two people have been talking about Mombasa, someone could use the sentence in (70). This means

that even in a case where the applied locative is a pronoun, there is a specified location that is referred to, which means that a pronominal locative of an applied object in fact has stronger truth conditions than the existentially bound source in the non-applied verb.

In addition to the *kw-ambuka* ‘to cross’ case, consider examples from another class of motion predicates, such as verbs that convey a change of location, such as *kw-injira* ‘to enter’, *gu-sohoka* ‘to exit’, *ku-rira* ‘to climb’, *ku-manuka* ‘to descend’, and *kuzamoka* ‘to ascend’. These verbs convey a motion along a route to a specified goal (though whether arrival at the goal is entailed depends on the verb). For example, consider the denotation of the verbs *kw-injira* ‘to enter’ in (71) and *gu-sohoka* ‘to exit’ in (72).

(71) a. $[[kwinjira]] := \lambda z \lambda y \lambda x \lambda e \exists p [entering'(e) \wedge ag'(e, x) \wedge goal'(e, y) \wedge route'(e, z) \wedge path'(e, p)]$

b. PAS: $\langle \underline{DP}_{ag} DP_{loc} \rangle$

(72) a. $[[gusohoka]] := \lambda z \lambda y \lambda x \lambda e \exists p [exiting'(e) \wedge ag'(e, x) \wedge source'(e, y) \wedge route'(e, z) \wedge path'(e, p)]$

b. PAS: $\langle \underline{DP}_{ag} DP_{loc} \rangle$

As with *kw-ambuka* ‘to cross’ above in (60), there are three participants with both *kw-injira* ‘to enter’ and *gu-sohoka* ‘to exit’. However, the specified individuals are different with different verbs; *kw-injira* ‘to enter’ specifies an agent, goal, and route, while *gu-sohoka* ‘to exit’ specifies an agent, source, and route. As with *kw-ambuka* ‘to cross’, the restriction on the number of locative arguments applies to these verbs as well, which means that the supernumerary argument must be existentially bound. In (73) and (74), I provide the denotations where the outermost argument has been existentially bound with *kw-injira* ‘to enter’ and *gu-sohoka* ‘to exit’, respectively.

(73) a. $\lambda y \lambda x \lambda e \exists z \exists p [entering'(e) \wedge ag'(e, x) \wedge goal'(e, y) \wedge route'(e, z) \wedge path'(e, p)]$

b. PAS: $\langle \underline{DP}_{ag} DP_{goal} \rangle$

- (74) a. $\lambda y \lambda x \lambda e \exists z \exists p [exiting'(e) \wedge ag'(e, x) \wedge source'(e, y) \wedge route'(e, z) \wedge path'(e, p)]$
 b. PAS: $\langle \underline{DP}_{ag} DP_{source} \rangle$

Note that in both (73) and (74), the individual linked to the route is the participant that is existentially bound, which means that the locative object of the non-applied variants of these verbs is the goal for *kw-injira* ‘to enter’ and the source for *gu-sohoka* ‘to exit’, as in (75) and (76).

- (75) a. *Uwase a-ri kw-injir-a mu n-zu.*
 Uwase 1-BE INF-enter-IMP 18 9-house
 ‘Uwase is entering the house.’
 b. $\exists e \exists z \exists p [entering'(e) \wedge ag'(e, uwase') \wedge goal'(e, house') \wedge route'(e, z) \wedge path'(e, p)]$
- (76) a. *Uwase y-a-sohots-e mu n-zu.*
 Uwase 1S-PST-exit-PERF 18 9-house
 ‘Uwase exited the house.’
 b. $\exists e \exists z \exists p [exiting'(e) \wedge ag'(e, uwase') \wedge source'(e, house') \wedge route'(e, z) \wedge path'(e, p)]$

In these examples, the locative object is either the goal or the source, depending on the meaning of the specific verb. In both cases, there is an unrealized route in the meaning of the verb that is existentially bound. Consider the composition of these two verbs with the meaning of the applicative in (65), which results in (77) for *kw-injira* ‘to enter’ and (78) for *gu-sohoka* ‘to exit’.

- (77) a. $\lambda z \lambda y \lambda x \lambda e \exists p [entering'(e) \wedge ag'(e, x) \wedge goal'(e, y) \wedge route'(e, z) \wedge loc'(e, z) \wedge path'(e, p)]$
 b. PAS: $\langle \underline{DP}_{ag} DP_{loc} DP_{loc} \rangle$

- (78) a. $\lambda z \lambda y \lambda x \lambda e \exists p [exiting'(e) \wedge ag'(e, x) \wedge source'(e, y) \wedge route'(e, z) \wedge loc'(e, z) \wedge path'(e, p)]$
 b. PAS: $\langle \underline{DP}_{ag} DP_{loc} DP_{loc} \rangle$

The result of applicativization in these cases is that the argument which is not licensed in the non-applied verb is linked to the locative participant introduced by the applicative. Thus the applied object for both *kw-injira* ‘to enter’ and *gu-sohoka* ‘to exit’ is a route.

- (79) a. *Uwase a-ri kw-injir-ir-a mu muryango (?mu n-zu).*
 Uwase 1-BE INF-enter-APPL-IMP 18 door 18 house
 ‘Uwase entered (the house) through the door.’
 b. $\exists e \exists p [entering'(e) \wedge ag'(e, uwase') \wedge goal'(e, house') \wedge route'(e, door') \wedge loc'(e, door') \wedge path'(e, p)]$
- (80) a. *Habimana y-a-sohok-ey-e mw' i-dirishya (?mu n-zu).*
 Habimana 1S-PST-exit-APPL-PERF 18 5-window 18 9-house
 ‘Habimana exited (the house) through the window’
 b. $\exists e \exists p [exiting'(e) \wedge ag'(e, habimana') \wedge source'(e, house') \wedge route'(e, window') \wedge loc'(e, window') \wedge path'(e, p)]$

In these cases, the applicative syntactically realizes the semantic participant that cannot be licensed by the non-applied verb for independent syntactic reasons. Note in these examples that the verbal object is dispreferred in the presence of the applied object. Speakers note that for the verbs *kw-injira* ‘to enter’ and *gu-sohoka* ‘to exit’, the presence of the goal or source, respectively, feels redundant, especially when the goal is *inzu* ‘house’. I assume that perhaps these verbs conventionally describe motion in/out of a house, and so it is not necessary to repeat the goal and thus it is often dropped.

In this section I have shown that in certain cases, the applicative gives syntactic license to a participant that is semantically present in the meaning of the verb (but syntactically unrealized). This was exemplified with various directed motion verbs from different classes, where — depending on the lexical specifications of the verb — the applied object is either

a source or route. In the next section I address another class of motion verbs that are subject to this analysis, namely manner of motion verbs. With this class of verbs, the applied object is a goal of motion, and I propose that the goal arises via a coercion in the semantics with verbs which implicate directed motion towards a goal.

4.7 Manner of Motion Verbs

In this section, I extend the analysis of locative applicatives to the (prospective) goal interpretation that is found when the applicative is used with certain manner of motion verbs. I argue that manner of motion verbs which independently show orientation towards a goal can be pragmatically coerced into having a prospective goal reading, and when the applicative is used, the applied object brings out this semantically coerced goal. The verbs in this class also allow an optional locative DP argument, further defining the grammatical properties of the class.

Certain manner of motion verbs which occur with a locative DP in their non-applied form are often construable as having a located motion reading as well as a directed motion reading.

- (81) *Uwase y-a-simbuts-e mu mazi.*
Uwase 1S-PST-jump-PERF 18 water
'Uwase jumped while in the water.' or 'Uwase jumped into the water.'

This pattern has been noted in several languages (Folli & Ramchand 2005, Nikitina 2008, Tham et al. 2012, Bassa Vanrell 2013). In English, for example, the preposition *in* in (82) is ambiguous in a similar way as the Kinyarwanda sentence in (81).

- (82) a. Pat jumped in the water.
b. Pat ran in the store.

In (82), both sentences are ambiguous between a located motion reading and a directed motion reading. A similar pattern is found in Romance, where the *in* is verb-specific variation

in whether locative prepositions may appear with directed-motion sentences.

- (83) a. *Gianni é corso in spiaggia.*
John is run.PST.PRT in beach
'John ran to the beach.' (Italian; Folli & Ramchand 2005:96,31a)
- b. **Gianni é camminato in spiaggia.*
John is walk.PST.PRT in beach
'John walked to the beach.' (Italian; Folli & Ramchand 2005:97,32a)
- (84) a. *Jean a jeté le livre sur la table.*
John has throw.PST.PRT the book on the table
'John threw the book onto the table (translation mine)'
(French; Jones 1996:394,59b)
- b. **Paul a marché à la gare.*
Paul has walk.PST.PRT to the station
'Paul walked to the station.' (French; Jones 1996:395,64a)
- (85) a. *Juan corrió al sótano.*
John ran.3RD.PST at.the cellar
'John ran to the cellar.' (Spanish; Bassa Vanrell 2013:10,10a)
- b. **La botella flotó a la cueva.*
the bottle floated.3rd.pst at the cave
'The bottle floated to the cave.' (Spanish; Bassa Vanrell 2013:11,10b)

The data in (83) – (85) from Italian, French, and Spanish show that motion prepositions do not universally license directional meaning, but rather, the directional reading is optionally brought out by specific verbs.

Analyses of these facts vary. One approach argues that the locative PPs such as *in*, *under*, and *on* in English are polysemous, with an optional feature specifying directionality (Folli & Ramchand 2005). However, as pointed out in Tham et al. (2012), a polysemy account fails to capture the fact that directed motion readings with these kinds of prepositions cannot be found across the same number of scenarios as clearly directional prepositions such as *into*, *onto*, etc. Following their example, the sentence in (86a) should be acceptable on a

directed motion reading in any context if it is truly polysemous.

- (86) a. John walked in the study.
b. John walked into the study.

However, the acceptability of (86a) is contingent upon context, preferring situations describing short, punctual types of motion. For example, in a situation where the subject is just outside of the study and walks into it, (86a) is more acceptable than in a situation where the subject must walk down the hallway into the study. This contrasts with *into* in (86b) which is categorically acceptable in any context on a directed motion reading. Tham et al. (2012) therefore propose instead that prepositions like ‘in’ are location-encoding, but the event description can be coerced into taking a location argument and assigning it a goal semantic role in particular contexts (see also Bassa Vanrell 2013 for a similar analysis where the meaning of the verb may be coerced).

An empirical reason to favor the location-encoding analysis for Kinyarwanda is that prepositions in Niger-Congo languages are generally semantically bleached, and rarely code goal or source (Creissels 2006). There are no prepositions in Kinyarwanda (and, to wit, all the languages under discussion in this dissertation) that mean ‘to’, ‘from’, ‘towards’, etc. As mentioned above, the three locative prefixes on DPs in Kinyarwanda mean ‘at’ or ‘in’, and there is no evidence that locative prefixes optionally include directional meaning.

The only way of creating an unambiguously directional phrase in Kinyarwanda is with what I refer to as a “coverb construction,” such as in (87) where the verbs *ku-jya* ‘to go to’ and *ku-va* ‘to come from’ introduce a new argument that is interpreted as a goal or source, respectively.³²

³²The coverb constructions in (87) have not been adequately described for Kinyarwanda, though they are frequently used in natural speech. A similar construction, referred to as Compound Tense Constructions (CTCs), are found in other languages such as Swahili, cf. Carstens (2001). However, in Swahili, CTCs carry tense information much in the way as Indo-European auxiliaries; in Kinyarwanda, the coverb constructions license directional information in complex motion events. I leave an analysis of these constructions for future research.

- (87) a. *Aba-na b-∅-iruts-e ba-jy-a kw' isoko.*
 2-child 2S-PST-run-PERF 2S-go-IMP 17 5-market
 'The children ran to the market.
- b. *Aba-na b-∅-iruts-e ba-v-a kw' isoko.*
 2-child 2S-PST-run-PERF 2S-come-FV 17 5-market
 'The children ran from the store.'

In (87), the verbs *ku-jya* 'to go to' and *ku-va* 'to come from' appear with the main verb to license a source or goal, respectively. Note that the locative class prefix *ku* 'at' is used in addition to the directional coverb, regardless of whether it expresses a source or a goal, further supporting the claim that locative class prefixes in Kinyarwanda do not themselves contribute goal or source information.

Given that the locative prefix in Kinyarwanda does not introduce motion, the question remains as to where the directed motion arises in sentences like (81). As mentioned above, some approaches have claimed that spatial prepositions are uniformly location-encoding, with no directional sense (Tham et al. 2012, Bassa Vanrell 2013). The directional reading in cases like (82), then, arises via coercion in certain contexts, generally when the event is displacement with a short, punctual transition of location into a location with a well-defined boundary (Thomas 2004, Nikitina 2008, Tham et al. 2012, Bassa Vanrell 2013). For example, consider Bassa Vanrell's analysis of Spanish verbs of directed motion such as *correr* 'to run', where displacement is "overwhelmingly" implicated by the verb and there is typically directed motion towards a goal. Her analysis is that the directional reading arises from coercion of the meaning of the verb, as shown in (88).

$$(88) \quad \llbracket \textit{correr} \rrbracket := \lambda e \exists p [\textit{run}'(e) \wedge \textit{path}'(e, p)] \rightarrow \\ \lambda g \lambda e \exists p [\textit{run}'(e) \wedge \textit{path}'(e, p) \wedge \textit{goal}'(e, p, g)]$$

(Bassa Vanrell 2013:50,(52b))

Her claim is that motion verbs such as *correr* 'to run' denote a path participant, but in certain pragmatic contexts where motion is implicated to be directed towards a goal, the

meaning is coerced, adding a new goal participant, effectively converting the manner of motion verb into a path verb. This allows the locative *a* DP to saturate the goal, resulting in goal readings of *a*-locatives:

- (89) *Juan corrió a la casa*
 John ran at the house
 ‘John ran to the house.’

In (89), the verb is coerced to license a goal argument, having the meaning that John ran to the house.

I adopt a similar analysis of coercion in manner of motion verbs for Kinyarwanda, although the meaning that is brought about by this coercion differs in one important respect: in Kinyarwanda, unlike English or Spanish, the arrival at the goal of a motion event is not entailed. For example, it is not a contradiction to say the following:

- (90) *Y-a-simbuk-iy-e ku meza, ariko biranga.*
 1S-PST-jump-APPL-PERF on table but fail
 ‘He jumped onto the table, but he failed (i.e. he did not get to the top of the table).’
- (91) *Y-∅-iruk-iy-e mu mu-jyi, ariko nt-ara-ger-a.*
 1S-PST-run-APPL-PERF in 3-town but NEG-PST-arrive-IMP
 ‘He ran to town, but he has not arrived.’

The data in (90) and (91) show that it is not a contradiction to say that someone did not reach the coerced goal of a motion event. Further evidence of the prospective nature of the arrival at the goal is that the applied predicates are also used in situations where there is no intention of conveying arrival, as in (92) in which the applied object has a ‘towards’ interpretation.

- (92) *Karekezi y-∅-iruk-iy-e kw’ i-duka.*
 Karekezi 1S-PST-ran-APPL-PERF at 5-store
 ‘Karekezi ran towards the store.’

I take these data to mean that in Kinyarwanda, the coercion provides a *prospective* goal of the motion event. Namely, the motion is directed *toward* a goal, but it is not entailed to arrive at it. I use the operator \diamond to indicate that the goal is not required to be reached, but rather that motion is directed towards it. Thus I propose a parallel coercion operation for Kinyarwanda to that in Bassa Vanrell (2013), which I provide in (93). I also provide the corresponding change in the PAS in (94), where there is no change in the argument structure.

$$(93) \quad \llbracket \textit{gusimbuka} \rrbracket := \lambda x \lambda e \exists p [\textit{jumping}'(e) \wedge \textit{ag}'(e, x) \wedge \textit{path}'(e, p)] \Rightarrow \\ \lambda z \lambda x \lambda e \exists p [\textit{jumping}'(e) \wedge \textit{ag}'(e, x) \wedge \textit{path}'(e, p) \wedge \diamond \textit{goal}'(e, z)]$$

$$(94) \quad \langle \underline{\text{DP}}_{ag} \rangle \Rightarrow \langle \underline{\text{DP}}_{ag} \rangle$$

In (93), the verb *gu-simbuka* ‘to jump’ is pragmatically coerced to have a prospective goal argument. Note that there are some crucial notational differences from Bassa Vanrell’s proposal in (88). First, in the formalism I use here, thematic relations are binary, linking an individual to an event, whereas Bassa Vanrell’s formalism allows relations among multiple participants. Furthermore, because arrival at the goal is prospective in Kinyarwanda, the formalism in (93) reflects prospectiveness of arrival at the goal.

The meaning of the applicative in (65) combines with the coerced meaning in (93), which results in the denotation and the associated PAS in (95).

$$(95) \quad \text{a. } \lambda z \lambda x \lambda e \exists p [\textit{jumping}'(e) \wedge \textit{ag}'(e, x) \wedge \textit{path}'(e, p) \wedge \diamond \textit{goal}'(e, z) \wedge \textit{loc}'(e, z)] \\ \text{b. } \langle \underline{\text{DP}}_{ag} \text{ DP}_{loc} \rangle$$

The denotation here states that there is an event of jumping which has an agent, a prospective goal, and a locative as participants. As with other motion verbs discussed above, such as *kw-ambuka* ‘to cross’ and *kw-injira* ‘to enter’, the locative role and the goal are semantically compatible, and so there is no contradiction with z being related to both. The prediction of this analysis is that a manner of motion verb which permits coercion will have

the coerced meaning with the applicative, as in the sentence in (96).

- (96) a. *Habimana y-a-simbuk-iy-e mu ma-zi.*
 Habimana 1-PST-jump-APPL-PERF 18 6-water
 ‘Habimana jumped into the water.’
 NOT: ‘Habimana jumped while in the water.’
- b. $\exists e \exists p [jumping'(e) \wedge ag'(e, habimana') \wedge route'(e, p)$
 $\wedge \diamond goal'(e, water') \wedge loc'(e, water')]$

The applied predicate in (96) has the interpretation that the subject jumped into a body of water, and crucially, it is not a general location.

Recall that this class of verbs also optionally allows a DP object in the non-applied variant. The verb *gu-simbuka* ‘to jump’ would thus have the alternative denotation in (97a) and the associated PAS with two arguments in (97b) in such a case. It is also possible that the non-applied verb may be coerced to add a prospective goal. In this case, I assume that there is no additional participant added to the semantics, but rather that the location here is reinterpreted to be a goal via a separate pragmatic process, effectively deriving a reading like the applicativized version. Thus in (98) is the coerced denotation in which the meaning of the verb has a prospective goal participant and the participant *y* is linked to both the general location and the prospective goal.

- (97) a. $\lambda y \lambda x \lambda e \exists p [jumping'(e) \wedge ag'(e, x) \wedge path'(e, p) \wedge loc'(e, y)]$
 b. $\langle \underline{DP}_{ag} DP_{loc} \rangle$
- (98) a. $\lambda y \lambda x \lambda e \exists p [jumping'(e) \wedge ag'(e, x) \wedge path'(e, p) \wedge loc'(e, y) \wedge \diamond goal'(e, y)]$
 b. $\langle \underline{DP}_{ag} DP_{loc} \rangle$

Thus the non-applied variant of *gu-simbuka* ‘to jump’ that occurs with a locative object is ambiguous between two readings. One is where the jumping occurred in a general location, while the other is that the location is a prospective goal of the motion event. The sentence in (99) exhibits this ambiguity.

(99) *Habimana y-a-simbutse mu ma-zi.*
Habimana 1-PST-jump-PERF 18 6-water

‘Habimana jumped into the water’ or ‘Habimana jumped while in the water.’

Depending on context, the sentence in (99) can describe a situation in which Habimana is jumping into the water (where the water is the goal of motion) or a situation in which Habimana is jumping up and down while already in the water (where the water is the general location).

Returning to the analysis of manner of motion verbs, it is crucial to note that not all manner of motion verbs in fact permit the coerced goal interpretation, both in Kinyarwanda and in the other languages which permit pragmatically conditioned coercion. For Spanish, Bassa Vanrell (2013) proposes three degrees of grammatically-relevant levels of displacement. Verbs like *temblar* ‘to shiver’ and *flotar* ‘to float’ are “low displacement” verbs, verbs like *saltar* ‘to jump’ and *correr* ‘to run’ are “overwhelming displacement” verbs, and verbs like *deslizarse* ‘to slide’ and *manejar* ‘to drive’ are “categorical displacement” verbs. The diagnostic she uses to probe whether a particular verb indicates displacement is the adjunct *sin desplazarse* ‘without displacement’, akin to English ‘in place’, which is felicitous when used with verbs which do not describe displacement.

The typology of manner of motion verbs in Kinyarwanda does not seem sensitive to displacement in the same way; most notably the verbs *k-oga* ‘to swim’, *ku-nyerera* ‘to slip’, and *gu-serebeka* ‘to slide’ do not permit goal coercion, which is not expected if displacement were the necessary condition for coercion; inherently, both *ku-nyerera* ‘to slip’ and *gu-serebeka* ‘to slide’ both require displacement, and *k-oga* ‘to swim’ often involves it (on the intended use of this verb).³³ However, a separate but related notion to displacement discussed in Bassa Vanrell (2013) is goal-resistance or “aimlessness.” In other words, does the predicate implicate an intention of movement towards a goal? Bassa Vanrell cites ex-

³³To date, it has not been possible to construct a suitable cognate diagnostic for displacement in Kinyarwanda, such as *sin desplazarse* ‘without displacement’ in Spanish used by Bassa Vanrell (2013) or *in place* in English. The closest test is *ahantu hamwe* ‘at the same place’, but this phrase is also used to mean something akin to ‘at the same place the event happened at some earlier time’, rather than ‘in the whole place for the duration of the action’.

amples in Spanish such as *deambular* ‘to wander’ and *corretear* ‘to run around’, as well as various verbs which describe activities related to pleasure or particular sports, such as *patinar* ‘to skate’, *esquiar* ‘to ski’ and *pasear* ‘to stroll’ (Bassa Vanrell 2013:33-35). These verbs are shown to resist a goal DP. The classification by degree of goal-resistance permits a more predictive typology for manner-of-motion verbs in Kinyarwanda than displacement; predicates which implicate the intention of going to a particular goal are those which are coercible, as in (100), while those which do not implicate such an intention are not, as in (101).

(100) Predicates of Goal-Orientedness: *kw-iruka* ‘to run’, *gu-tembera* ‘to stroll’,
gu-simbuka ‘to jump’

(101) Goal-Resistant Predicates: *ku-byina* ‘to dance’, *gu-titira* ‘to shiver’, *k-oga* ‘to swim’,
gu-serebeka ‘to slide’, *ku-nyerera* ‘to slip’, *gu-kambakamba* ‘to crawl’

The two categories in (100) and (101) are based on intuitions from native speakers regarding whether these specific predicates describe an intention to go anywhere. For example, a sentence like that in (102) describes a situation in which the children have thrown water on a concrete floor and are sliding around on the wet floor, and crucially, not with the intention of going to a place.

(102) *Aba-na ba-ri gu-serebeka.*
2-child 2S-COP INF-slide
‘The children are sliding.’

(103) a. $\llbracket gu-serebeka \rrbracket := \lambda x \lambda e [sliding'(e) \wedge ag'(e, x)]$
b. $\langle \underline{DP}_{ag} \rangle$

Here, the meaning of *gu-serebeka* ‘to slide’ is an event with an agent and no other participants or components of motion in its denotation. This means that the verb *gu-serebeka* ‘to slide’ does not pattern with directed motion verbs but is instead is expected to pattern

with non-motion verbs. This means that with the locative applicative, *gu-serebeka* ‘to slide’ combines with the meaning in (43), where the applicative adds a new locative participant to the meaning of the verb and a corresponding locative object to the syntax, as in the denotation and corresponding PAS in (104b).

- (104) a. $\lambda l \lambda x \lambda e [sliding'(e) \wedge ag'(e, x) \wedge loc'(e, l)]$
 b. $\langle \underline{DP}_{ag} DP_{loc} \rangle$

This predicts that the applied object of the verb *gu-serebeka* ‘to slide’ has a general locative applicative reading, which is borne out in (105), where the children’s sliding takes place in the room.

- (105) *Aba-ana ba-ri gu-serebek-*(er)-a mu cy-umba.*
 2-child 2S-COP INF-slide-APPL-IMP in 7-room
 ‘The children slid (around) in the room.’

- (106) a. $\exists e [sliding'(e) \wedge ag'(e, children') \wedge loc(e, room')]$
 b. $\langle \underline{DP}_{ag} DP_{loc} \rangle$

The verb *gu-serebeka* ‘to slide’, patterns with non-motion verbs, adding a general locative in the applied variant. Furthermore, as with other non-motion verbs, note that the applicative is obligatory for the licensing of the locative argument in (105).

4.8 Modifying the Semantic Role of an Extant Syntactic Argument

So far, I have discussed two methods for satisfying the Applicativization Output Condition with a locative applicative: one is where the addition of a new locative participant in the semantics (and corresponding object in the syntax) restricts the truth conditions by specifying where the event occurred. This was the case with verbs like *ku-vuga* ‘to talk’, where the applied object is a general location. The second case was that the applicative syntactically realizes an entailed participant of the event described by the verb that cannot be realized

by the non-applied verb. In this case, the AOC is satisfied by the location described by the verb being specified by overt linguistic material instead of being implicit and interpreted purely existentially.

In the section, I present a third strategy for satisfying the AOC, which is where there is no additional argument added to the syntax, but instead, the applied variant of the verb adds semantic information to the thematic role of an already extant internal argument of the verb. Specifically, with the ditransitive verb *gu-tera* ‘to throw,’ the goal argument of the non-applied verb is a recipient with the applied verb, with no addition of a new object in the applied case. Below I analyze recipients as “upgraded” goals, with additional entailments of prospective receiving in addition to the arrival described by a goal. This satisfies the AOC by narrowing the truth conditions of an internal object in the applied variant.

Consider the verb *gu-tera* ‘to throw’ in (107), which describes the throwing of some theme at a goal in its non-applied use.

- (107) *Habimana y-a-tey-e Karekezi i-buye .*
Habimana 1-PST-throw-PERF Karekezi 5-rock
‘Habimana threw the rock at Karekezi.’

The sentence in (107) specifically means that Habimana is pelting a rock at Karekezi, possibly trying to harm him and — crucially — without the intention of giving Karekezi possession of the rock. In fact, a better gloss of the verb may be something to the effect of *pelt* in English. This meaning contrasts with the meaning of the applied use, where Karekezi is instead an intended recipient of the throwing, as in (108).

- (108) *Habimana y-a-ter-ey-e Karekezi i-buye.*
Habimana 1-PST-throw-APPL-PERF Karekezi 5-rock
‘Habimana threw the rock to Karekezi.’

The contrast between (107) and (108) is whether Karekezi is interpreted as the goal (in the former) or as a recipient (in the latter), and, crucially, there is no difference in the number of arguments between the two sentences.

I propose the denotation in (109) for the non-applied use of the verb *gu-tera* ‘to throw’.

- (109) a. $\llbracket \textit{guter}a \rrbracket := \lambda z \lambda y \lambda x \lambda e [\textit{throwing}'(e) \wedge \textit{ag}'(e, x) \wedge \textit{th}'(e, y) \wedge \diamond \textit{goal}'(e, z)]$
 b. $\langle \underline{\text{DP}}_{ag} \text{DP}_{loc} \text{DP}_{th} \rangle$

This denotation states that there are three individuals, and describes a situation where an agent acts to throw some theme at a goal. Even in cases where the goal is animate, as in (107), there is no implication of intended transfer of possession.

I adopt a similar semantics for the benefactive applicative as the locative applicative associated with motion predicates in (65), where the applicative introduces a relation for an argument present in the denotation of the verb and crucially not adding a new semantic participant. Unlike the case with motion verbs, in (110) there is no addition of a syntactic argument in the PAS. I assume that the applicative is associated with a beneficiary role (notated as *ben'*) which is an animate entity that benefits from the event.³⁴ In this case, there is no additional argument added in the PAS, as shown in (110b), where any arguments in the non-applied variant are the same arguments found in the applied variant.

- (110) a. $\llbracket -\textit{ir}_{ben} \rrbracket := \lambda P \lambda x_1 \dots \lambda x_n \lambda e [P(x_1 \dots x_n, e) \wedge \textit{ben}'(e, x_1)]$
 b. $\langle \dots \rangle \Rightarrow \langle \dots \rangle$

The denotation of the benefactive applicative in (110) takes a predicate *P*, and states that the first argument of the verb is the beneficiary of the event. It is worth noting that the meaning of beneficiaries differs across languages (Kittilä 2005, Kittilä & Zúñiga 2010), and I leave future work to tease apart the formal analysis of the various kinds of meanings found with benefactives in Bantu languages. For the present purposes, the most relevant meaning that frequently overlaps with the meaning of a beneficiary is that of a recipient, i.e. one who comes into possession of an item and benefits by virtue of possessing it (cf.

³⁴There are also cases with other verbs where the benefactive applicative adds a wholesale new beneficiary object to the argument structure, paralleling the semantics in (43). I focus here just on the case in (110) as it is illustrative of a use of the applicative to restrict the semantic role of an already present syntactic argument.

Kittilä’s 2005 notion of recipient-beneficiary, or “Rb”). This case, unlike the cases above, appears to be truly lexicalized to this specific verb.³⁵ I represent the applicative in (110) in order to discuss the relationships formally, but I do not assume that this meaning is productive.

The interrelationship between goals and recipients has been observed in several languages, such as in English, where ballistic motion verbs (e.g. *throw*, *toss*) encode caused motion in both the double object and *to*-oblique marked variants, as in (111), though prospective possession is encoded in the double object realization.

- (111) a. John threw Mary the ball.
 b. John threw the ball to Mary.

Often these two variants are analyzed as separate event structures, such as those in (112a) and (112b) for the direct object and oblique realizations, respectively, though analyses differ in whether the frames are lexical, constructional, or syntactic (Pinker 1989, Goldberg 1995, Harley 2003, Rappaport Hovav & Levin 2008), a point which I leave aside here (cf. Chapter 2, §2).

- (112) a. [[x ACT] CAUSE [y HAVE z]]
 b. [[x ACT] CAUSE [z GO-TO y]]

Beavers (2011a) subsumes these frames under a broader analysis of scales of change, by extending a scalar analysis of change of state in Beavers (2011b) to these ditransitive predicates, which (depending on the particular verb) encode a scale of caused motion and/or a potentially associated scale of caused possession. For the class of ballistic motion verbs (relevant here) he analyzes the different variants via a “caused possession interpretation rule” for this class of verbs, which states that with a predicate which entails arrival, it can

³⁵There is in fact another verb for throwing: *ku-jugunya* ‘to throw’. However, the two differ in that *ku-jungunya* is transitive in its non-applied form, i.e. there is no goal participant. With a benefactive applicative, the applied object is a recipient or (true) beneficiary, depending on context. I leave a detailed comparison of *gu-tera* ‘to throw’ and *ku-jugunya* ‘to throw’ to future research, assuming for now that the key difference is in the difference in number of arguments the two verbs allow in their non-applied variants.

also be inferred that the predicate encodes prospective receiving. Note that Beavers provides a more comprehensive analysis of ditransitive verbs than the present chapter, as my goal in this section is to make a more preliminary point, centered around the fact that the caused motion verb *gu-tera* ‘to throw’ does not add a new argument under applicativization, but instead there is a change of the goal argument of the non-applied verb to a recipient. The fact that it is a goal that is “upgraded” to a recipient intersects with a more general literature on ditransitive verbs, and I leave future work to extend the current discussion with ditransitive verbs more generally.

Following Beavers (2011), I assume that the recipient reading of a ballistic motion verb has the same lexical entailments as the goal-oriented reading with the addition of prospective receiving of the theme.³⁶ In the formal analysis I use here, I analyze a recipient as a role that is the union of the entailments of the roles of *goal* and *beneficiary*.³⁷ The goal meaning is contributed by the verb, and the beneficiary is contributed by the applicative, essentially analyzing the combination of the implications of arrival and a benefactivity as a type of possession.

Consider the composition of the meaning of the verb *gu-tera* ‘to throw’ (109) with the meaning of the applicative in (110), which gives the denotation and corresponding PAS in (113).³⁸

- (113) a. $\lambda z \lambda y \lambda x \lambda e [throwing'(e) \wedge ag'(e, x) \wedge th'(e, y) \wedge goal'(e, z) \wedge ben'(e, z)]$
 b. $\langle \underline{DP}_{ag} DP_{loc} DP_{th} \rangle$

In this case, the argument z is a participant linked to both the goal and the beneficiary, which means that it must satisfy the entailments of both roles, resulting in a recipient reading. Thus the applied variant of *gu-tera* ‘to throw’ means that the subject threw the theme to a recipient, as in the example in (114a), with the meaning in (114b).

³⁶Note that this is limited to ballistic motion verbs, which always encode caused motion.

³⁷I assume that it is a beneficiary that is added since beneficiaries are a role often added by applicatives. The crucial point here is that with the applied variant of *gu-tera* ‘to throw’, there is an animate individual capable of reception.

³⁸Recall that there is no syntactic object added in this case, and so the PAS is unchanged.

- (114) a. *Habimana y-a-ter-ey-e Karekezi i-buye.*
 Habimana 1-PST-throw-APPL-PERF Karekezi 5-rock
 ‘Habimana threw the rock to Karekezi.’
- b. $\exists e[\textit{throwing}'(e) \wedge \textit{ag}'(e, \textit{habimana}') \wedge \textit{th}'(e, \textit{rock}') \wedge$
 $\textit{goal}'(e, \textit{karekezi}') \wedge \textit{ben}'(e, \textit{karekezi}')]]$

Crucially, the reading in (114a) is one in which Habimana is attempting to give Karekezi possession of the rock, and not that Habimana is pelting Karekezi with a rock, as was the case with the non-applied variant in (107).

Consider the contrast in meaning between the applied and non-applied variants of *gu-tera* ‘to throw’. With the non-applied predicate in (115a), the only interpretation is that the ball is being thrown to the other side of the court, such as in a game of basketball. With the applied variant in (115b), on the other hand, the only possible interpretation is that the ball is being thrown to a person who is on the other side of the court.³⁹

- (115) a. *N-a-tey-e umu-pira hirya.*
 1S-PST-throw-PERF 3-ball beyond
 ‘I threw the ball to the other side.’
- b. *N-a-ter-ey-e umu-pira hirya.*
 1S-PST-throw-APPL-PERF 3-ball beyond
 ‘I threw the rock to the person on the other side.’

Additionally, consider the contrast in the sentences in (116), which are equivalent except for the presence of the applicative in (116b) and the absence of the applicative in (116a). In both cases the agent subject is throwing a ball, and the intended endpoint of the throwing event is Uwase. With the non-applied variant, Uwase is not the recipient, and this sentence could be used to describe the throwing involved in a game of dodgeball. With the applied variant, on the other hand, Uwase is the recipient of a pass, such as in a game of basketball.

³⁹This is comparable to the so-called ‘London Office’ effect in English (Green 1974, Rappaport Hovav & Levin 2008, Beavers 2011a), where a location (such as London) in the indirect object frame of a ditransitive verb is only felicitous if interpreted as a possible recipient (such as an office in London). See Chapter 2, §2.

- (116) a. *N-a-tey-e* *umu-pira Uwase.*
 1SGS-PST-throw-PERF 3-ball Uwase
 ‘I threw the ball at Uwase.’
- b. *N-a-ter-ey-e* *umu-pira Uwase.*
 1SGS-PST-throw-APPL-PERF 3-ball Uwase
 ‘I threw the ball to Uwase.’

The contrast in meaning between (115) and (116) exemplifies the difference between the non-applied and applied variants of the verb *gu-tera* ‘to throw’. There are the same number of participants in both, but the nature of the throwing differs as to whether the indirect object is just the goal or also the recipient.

Furthermore, it is pragmatically odd to modify the non-applied variant with a phrase that contrastingly denies the catching of the ball, since in this case, there is no implication of the goal having caught the ball in the first place. For example, in (117b), saying that Karekezi did not catch the rock violates a conventional implicature of *ariko* ‘but’ by which one expects the two clauses to contrast in their expectations. Because there is no notion of receiving in the non-applied case, it is not possible to contrast the expectation that Karekezi caught the ball. In the applied predicate, on the other hand, the two clauses do in fact contrast in their expectations, since there is crucially a notion of receiving in the applied variant of *gu-tera* ‘to throw’.

- (117) a. *Habimana y-a-ter-ey-e* *i-buye Karekezi, ariko Karekezi*
 Habimana 1S-PST-throw-APPL-PERF 5-rock Karekezi, but Karekezi
nti-y-a-ri-fash-e.
 NEG-1S-PST-5O-catch-PERF
 ‘Habimana threw the rock to Karekezi, but Karekezi didn’t catch it.’
- b. *#Habimana y-a-tey-e* *i-buye Karekezi, ariko Karekezi*
 Habimana 1SG-PST-throw-PERF 5-rock Karekezi but Karekezi
nti-y-a-ri-fash-e.
 NEG-1S-PST-5O-catch-PERF
 ‘Habimana threw the rock at Karekezi, but Karekezi didn’t catch it.’

The contrast in the expectation of Karekezi’s catching of the rock is possible in (117a)

because Karekezi is a prospective recipient of the throwing event. In the non-applied variant in (117b), however, Karekezi is the goal and is not intended to catch the rock.

Finally, in both the applied and non-applied predicates, the corresponding goal or recipient has the same objecthood properties in both cases, supporting the claim that there is no change in the argument structure of the two variants. The non-applied ditransitive verb *gu-tera* ‘to throw’ is symmetrical with respect to word order, ability to be the subject of a passive verb, and ability to be marked as an object marker on the verb, as shown in (118) to (120).

- (118) a. *Uwase a-ri gu-tera Karemera i-buye.*
 Uwase 1S-COP INF-throw Karemera 5-rock
 ‘Uwase threw the rock at Karemera.’
- b. *Uwase a-ri gu-tera i-buye Karemera.*
 Uwase 1S-COP INF-throw 5-rock Karemera
 ‘Uwase threw the rock at Karemera.’
- (119) a. *I-buye ry-ari gu-ter-w-a Karemera.*
 5-rock 5S-COP COP-throw-PASS-IMP Karemera
 ‘The rock is being thrown at Karemera.’
- b. *Karemera a-ri gu-ter-w-a i-buye.*
 Karemera 1S-COP INF-throw-PASS-IMP 5-rock
 ‘Karemera is being thrown rocks at.’
- (120) a. *Uwase y-a-ri-tey-e Karemera.*
 Uwase 1S-PST-5O-throw-PERF Karemera
 ‘Uwase threw it at Karemera.’
- b. *Uwase y-a-mu-tey-e i-buye.*
 Uwase 1S-PST-1O-throw-PERF 5-rock
 ‘Uwase threw the rock to him.’

Similarly, the applied variant of the verb shows the same symmetry across all three diagnostics, as shown in (121) to (123).

- (121) a. *Uwase a-ri gu-ter-er-a Karemera i-buye.*
 Uwase 1S-COP INF-throw-APPL-IMP Karemera 5-rock
 ‘Uwase is throwing the rock to Karemera.’
- b. *Uwase a-ri gu-ter-er-a i-buye Karemera.*
 Uwase 1S-COP INF-throw-APPL-IMP 5-rock Karemera
 ‘Uwase is throwing the rock to Karemera.’
- (122) a. *I-buye ry-a-ter-e-w-e Karemera.*
 5-rock 5S-PST-throw-APPL-PASS-PERF Karemera
 ‘The rock was thrown to Karemera.’
- b. *Karemera y-a-ter-e-w-e i-buye.*
 Karemera 1S-PST-throw-APPL-PASS-PERF 5-rock
 ‘Karemera was thrown the rock.’
- (123) a. *Uwase y-a-mu-ter-ey-e i-buye.*
 Uwase 1S-PST-1O-throw-APPL-PERF 5-rock
 ‘Uwase threw the rock to him.’
- b. *Uwase y-a-ri-ter-ey-e Karemera.*
 Uwase 1S-PST-5O-throw-APPL-PERF Karemera
 ‘Uwase threw it to Karemera.’

The comparable symmetry data for both applied and non-applied predicates further shows that in both cases, the goal/recipient DP is a core argument. This supports the analysis that the relevant difference indicated by the applicative is solely in the semantics of the thematic role, and not in any syntactic argument structural shift.

To date, *gu-tera* ‘to throw’ is the only example from Kinyarwanda where a verb shows the pattern of the applicative augmenting the thematic role of an already overt goal argument of the verb. Other semantic ditransitive verbs show patterns parallel to those discussed earlier in this section with motion verbs and non-location-encoding verbs. For example, with *gu-ha* ‘to give’, a wholesale benefactive object is added to the predicate, as shown in (124), where *Nkusi* is a (true) beneficiary of the giving event in (124b).

- (124) a. *Uwase y-a-ha-ye Mukamana igi-tabo.*
 Uwase 1SGS-PST-give-PERF Mukamana 7-book
 ‘Uwase gave the book to Mukamana.’
- b. *Uwase y-a-h-er-eye Nkusi igi-tabo Mukamana.*
 Uwase 1SGS-PST-give-APPL-PERF Nkusi 7-book Mukamana
 ‘Uwase gave the book to Mukamana for Nkusi.’

With *k-ohereza* ‘to send’, the applicative licenses a recipient object that is not licensed in the non-applied variant of the verb, as in (125).⁴⁰

- (125) a. *Uwase y-∅-oher-eje i-barwa.*
 Uwase 1S-PST-send-PERF 9-letter
 ‘Uwase sent a letter.’
- b. *Uwase y-∅-oher-er-eje Nkusi i-barwa.*
 Uwase 1S-PST-send-PERF Nkusi 9-letter
 ‘Uwase sent the letter to Nkusi.’

I assume that these two cases are parallel to the analyses provided above. For *gu-ha* ‘to give’, the applicative adds a wholesale new argument, as in the general case discussed in §4.1. With *k-ohereza* ‘to send’ on the other hand, the benefactive applicative overtly licenses an argument semantically implied in the meaning of the verb, comparable to the case in §4.2 with verbs of motion. I leave a detailed analysis of ditransitive verbs for future research, but I am optimistic that the analysis presented here can provide insight into the uses of the applicative with these verbs.

4.9 Summary

I have proposed an analysis of applicativization that extends beyond the canonical use of adding a new syntactic argument and associated semantic role, capturing two additional patterns: (1) verbs which encode motion in their meaning that the locative applicative can

⁴⁰I have not yet collected judgments regarding whether a recipient is entailed in the non-applied variant of *k-ohereza* ‘to send’, such as in (125). There are two possibilities given the analysis here: first, there is a recipient entailed in the meaning of the verb, and this participant is brought syntactically out by applicativization; alternatively, there is a goal selected by the meaning of the base verb, and the reading with the benefactive applicative is that the argument is narrowed to be a recipient.

bring out syntactically, and (2) verbs where the applicative gives new meaning to an extant syntactic argument of the base verb. Verb classes differ in the output of applicativization, though exactly why particular verbs should behave as they do remains a question for future inquiry. The larger point is that all patterns of applicativization satisfy the Applicativization Output Condition, which restricts the applied variant to have stronger lexical entailments associated with some internal argument than the non-applied variant. In addition to the three types of syntactic and semantic relations just discussed, there are also three types of productivity in the data discussed above: generally operative (where there is a general location added), operative within a narrow verb class (such as with motion verbs), and fully lexicalized (such as with the verb *gu-tera* ‘to throw’). However, blocking seems to apply in that the more narrowly constrained uses of the applicative seem to block the more general ones, with the common thread across all uses being that the applied variant of a given verb always has stricter lexical entailments than the non-applied variant.

5 Conclusion

In this chapter I have argued for an analysis of applicativization via a paradigmatic condition on the verb’s arguments, where the lexical entailments of the predicate of the applied variant are a strict superset of the entailments of the non-applied predicate. Focusing mostly on locative applicatives, I showed that there are three ways in which this condition can be satisfied. In the first case, the applied variant has a wholesale new argument and corresponding semantic participant, capturing the kind of applicativization operation assumed on the traditional view of applicativization. In the second case, the applied verb brings out a participant semantically present (though syntactically unrealized) in the non-applied verb. With the third case, the applied variant has narrower truth conditions with respect to the semantic role assigned to a particular already present syntactic argument of the verb.

This has not meant to be an exhaustive discussion of all applied verb meanings in Kin-

yarwanda, but rather the presentation of the typology of ways in which the applied variant satisfies the AOC. The framework presented here provides a unified analysis for uses of the applicative which do not conform to the traditional analysis of adding a wholesale new object to the argument structure, i.e. cases where there is no new argument or the semantic role is determined by the verb. As mentioned in Chapter 1 and in §2 of the present chapter, there have been cases cited in various other Bantu languages where the applied object either modifies the meaning of an extant role or brings out a specific thematic role type contingent upon the meaning of the verb. While I do not provide the details of how the present analysis captures these facts in other languages, the approach can presumably extend naturally to cases in other languages.

Chapter 4: The Causative-Instrumental Syncretism

1 Introduction

In this chapter, I investigate another domain where semantics plays a crucial role in the argument realization of valency-changing morphology — namely, the syncretism between the morphological causative and instrumental applicative in Kinyarwanda.¹ This syncretism is interesting from the point of view of argument structure because the two putatively distinct uses are traditionally analyzed as adding different grammatical functions: causatives add a new subject (demoting the subject of the base verb to object or some other internal grammatical function), while applicatives add a new object.

In many languages, the two functions are marked with distinct morphology, such as Chicheŵa, which has the morphological causative *-its* and the applicative suffix *-ir*, which licenses an instrumental object, among other roles.² Consider (2a) and (2b), which give examples of the applicative and causative morphemes, respectively.

- (1) *Mw-ana a-na-phwany-a kapu.*
1-child 1S-PST-break-FV 5.cup
'The child broke the cup.'
- (2) a. *Mw-ana a-na-phwany-ir-a kapu n-dodo.*
1-child 1S-PST-break-APPL-FV 5.cup 9-stick
'The child broke the cup with a stick.'
- b. *A-mayi a-na-phwany-its-a mw-ana kapu.*
2-mother 2S-PST-break-CAUS-FV 1-child 5.cup
'The mother made the child break the cup.'

Both (2a) and (2b) are derived from the base verb *ku-phwanya* 'to break' in (1), and while

¹Traditionally, the term "syncretism" refers to the merging of different inflectional varieties of a morpheme during the development of a language. Here, I use the term synchronically, discussing a morphological form with two distinct (though related) uses. See Section 4 for discussion of the historical situation that gave rise to their merge between these two uses.

²Following the claims made in the previous chapter, I expect there to be variation in the function of applicatives in other Bantu languages, including Chicheŵa. The data in (2b) and (2a) show that the causative and applicative are formally distinct in Chicheŵa, though an in-depth discussion of the influence of semantics on the possible uses of these morphemes remains for future research. See §5.4 for a discussion of the interaction of these two morphemes as well as Chapter 5 for data pertaining to the syntax of both morphemes.

both have the same result of creating a ditransitive, the two are usually analyzed as separate operations (cf. Baker 1988, Alsina & Mchombo 1993 on applicatives; Li 1990, Alsina 1992 on causatives; and Mchombo 2004 on Chicheŵa morphosyntax more broadly), where the applicative in (2a) adds a new object and the causative adds a new causer subject in (2b). Crucially, the form and presumed function of the two morphemes are distinct in this case.

However, several genetically unrelated and areally non-contiguous languages have morphological forms which subsume both causative and applicative uses, such as Hualapai (Ichihashi-Nakayama 1996), Francisco Leon Zoque (Engel & Allhiser de Engel 1987), Náhuatl (Tuggy 1988), Wolof (Comrie 1989:183), Caquinte (Swift 1988), Yidiny (Dixon 1977), Malay (Hemmings 2013), Indonesian (Son & Cole 2008), Mbu- un (Bostoen & Mundeke 2011), and several Great Lakes Bantu languages, such as Runyambo (Rugemalira 1993) and Haya (Byarushengo et al. 1977). In this chapter, I investigate the semantic and argument structural underpinnings of the syncretic morpheme *-ish* in Kinyarwanda, which has been often pointed to as a quintessential example of causative-instrumental applicative syncretism (see, for example, Croft 1991, Ichihashi-Nakayama 1996, Shibatani & Pardeshi 2002).³ In this language, the morpheme *-ish* is used as both a causative and an instrumental applicative, as in (4a) and (4b), respectively.⁴

- (3) *Habimana y-a-men-a igi-kombe.*
 Habimana 1S-PST-break-IMP 7-stick
 ‘Habimana broke the cup.’

- (4) a. *Habimana y-a-men-esh-eje umw-ana igi-kombe.*
 Habimana 1S-PST-break-ISH-IMP 1-child 7-cup
 ‘Habimana made the child break the cup.’

³Not all languages with a causative-applicative syncretism necessarily have an overlap with the causative and instrumental *per se*. Other roles that may share marking with morphological causatives include benefactive and comitative (Peterson 2007:64-65). I leave the analysis of these systems to future work, though many of the features of the analysis for Kinyarwanda may bear on the question of syncretism with other semantic roles.

⁴Throughout this chapter, I remain agnostic to in labeling the *-ish* morpheme as a causative or instrumental applicative; instead, I gloss it as *-ISH*.

- b. *Habimana y-a-men-esh-eje igi-kombe in-koni.*
 Habimana 1S-PST-break-ISH-IMP 7-cup 9-stick.
 ‘Habimana broke the cup with a stick.’

The sentence in (3) has two participants, mapped to subject and object. The *-ish*-marked sentences in (4a) and (4b) both have three, with two objects and a single subject. The interpretation differs slightly between the two: in (4a), Habimana acts on the child, causing the child to break the cup. In (4b), Habimana acts directly on the cup via a stick in order to bring about the change of state of the cup becoming broken. In other words, the child is the one doing the breaking in (4a), while it is Habimana who does it in (4b).

The question that arises for sentences with *-ish* like those in (4) is what the argument structure that is contributed by the *-ish* morpheme is. On the traditional view, *-ish* in (4a) adds a new subject, while in (4b), *-ish* adds an instrumental object, but how could one valency-changing operation cover both of these seemingly distinct uses? One possible solution is to propose accidental homophony, analyzing the use in (4a) as a separate operation from that in (4b). On this view, the homophony of the two is accidental and there no semantic relationship between the two. While this may be a tenable analysis for certain languages, in §4 I argue against a homophony analysis for Kinyarwanda, providing semantic, grammatical, and diachronic evidence that the two putatively distinct uses are better analyzed as outgrowths of the same operation.

Instead of homophony, I propose that *-ish* is an operation in which a new causal link and associated participant is added into the causal chain of the event, subsuming causees and instruments under the same semantic role. Constraints on possible event types (i.e. event structures) in conjunction with idiosyncratic verb meanings conspire to constrain how the new causal link is integrated into the event as described by the base verb, which in turn determines whether this new link’s associated participant is interpreted as an instrument or a causer. On this analysis, the shared grammatical function and semantic contribution of the two uses of the morpheme follow naturally without having to posit unmotivated separate

structures for the two. Furthermore, it is possible to derive the similar syntactic behavior of the two distinct uses, such as the fact that in either use both objects can appear as the subject of a passive or be object-marked on the verb. Additionally, this analysis fits with diachronic evidence that the causative morpheme spread to the instrumental applicative functionality in Kinyarwanda, as well as the overlap of causative and instrumental readings in related languages with distinct morphology for the two (e.g. in Chicheŵa). Finally, the analysis I propose is sensitive to verb meaning, capturing the fact that certain readings are ruled out with certain semantic verb classes.

The structure of the remainder of this chapter is as follows. In the next section, I give a descriptive summary of the uses of *-ish*. In section 3, I survey previous approaches to the structure of applicative and causative morphology in order to explicate the incompatibility of unifying previous analyses of causatives and applicatives to capture the syntax and semantics of *-ish*. Section 4 argues against a homophony analysis of the *-ish* morpheme, and Section 5 provides an analysis of the syncretism based around the shared semantics of causees and instruments. Section 6 concludes the discussion.

2 The morpheme *-ish*

In this section, I provide a description of the various uses of the *-ish* morpheme. With many verbs, both causative and instrumental uses are available, though there are restrictions on particular readings with specific verb classes. Consider the data in (6) where the causative and instrumental readings are used with the verb *kw-andika* ‘to write’.⁵

- (5) *Umw-arimu y-a-ndits-e in-kuru.*
 1-teacher 1S-PST-write-PERF 9-story
 ‘The teacher wrote the story.’

⁵The verb *kw-andika* ‘to write’ has the allomorph *andits* when used with the perfective morpheme *-e*.

- (6) a. *Umw-arimu y-a-ndik-ish-ije in-kuru i-karamu.*
 1-teacher 1S-PST-write-ISH-PERF 9-story 5-pen
 ‘The teacher wrote the story with a pen.’
- b. *Umw-arimu y-a-ndik-ish-ije umw-ana in-kuru.*
 1-teacher 1S-PST-write-ISH-PERF 1-child 9-story
 ‘The teacher made the child write the story.’

In this example, the verb marked with *-ish* has an additional argument compared to the bare verb in (5). In (6a) one of the objects is an instrument that is used to bring about the event; in (6b), there is a causee who is made to perform a writing event. Many transitive verbs from a variety of verb classes allow both interpretations, e.g. creation verbs, such as *ku-baka* ‘to build’, ingestive verbs such as *ku-rya* ‘to eat’ and *ku-nywa* ‘to drink’, and caused change-of-state verbs such as *ku-mena* ‘to break’, *ku-vuna* ‘to break/snap’ and *kw-ica* ‘to kill’.

Both readings can also be found with unergative verbs. Consider, for example, the verb *gu-kora* ‘to work’ in (8), which has both a causative and instrumental reading.

- (7) *Umu-gabo y-a-koz-e.*
 1-man 1S-PST-work-PERF
 ‘The man worked.’
- (8) a. *Umu-gabo y-a-kor-esh-eje i-suka.*
 1-man 1S-PST-work-ISH-PERF 5-hoe
 ‘The man is working with the hoe.’ (Overdulse 1975:209)
- b. *Umw-arimu y-a-kor-esh-eje umw-ana.*
 1-teacher 1S-PST-work-ISH-PERF 1-child
 ‘The teacher made the child work.’

Unaccusative verbs, such as *ku-rumbura* ‘bloom’, on the other hand, do not allow the instrumental reading, such as in (10a).

- (9) *In-dabyo z-a-rumbuy-e.*
 CL10-flowers CL11S-PST-bloom-PERF
 ‘The flowers bloomed.’

- (10) a. #*In-dabyo zi-ra-rumbur-ish-ije ibi-babi bya-zo.*
 10-flowers 10S-pst-bloom-ISH-PERF 8-petals 8-theirs
 Intended: ‘The flowers used their petals to bloom.’
- b. *I-mana y-a-rumbur-ish-ije ibi-babi.*
 9-god 9S-PST-bloom-ISH-PERF 8-petals
 ‘God made the flowers bloom.’

While unaccusative verbs do not permit the instrumental use, other verbs instead do not allow the causative reading; specifically, verbs which entail the use of an instrument — such as *gu-kata* ‘to cut’ and *gu-kubita* ‘to hit’. In (12b), the causative reading does not obtain with the verb *gu-kata* ‘to cut’, while the instrumental reading in (12a) is permitted.

- (11) *Umu-silikari y-a-tem-ye igi-ti.*
 1-hunter 1S-PST-cut-PERF 7-tree
 ‘The hunter cut the tree.’
- (12) a. *Umu-silikari y-a-kat-ish-ije igi-ti umu-horo.*
 1-soldier 1S-PST-cut-ISH-PERF 7-tree 3-machete
 ‘The soldier cut the tree with a machete.’
- b. #*Umu-silikari y-a-kat-ish-ije umw-ana igi-ti.*
 1-soldier 1S-PST-cut-ISH-PERF 1-child 7-tree
 Intended: ‘The soldier made the child cut the tree.’

It is also important to note that causative readings of *-ish* pattern with the reading of lexical causatives, i.e. verbs that lexically entail causation no explicit marking of it. Consider for example the contrast between the English causative verb *break* and the periphrastic causative *cause to break*.

- (13) a. John broke the vase.
 b. John caused the vase to break.

Lexical and periphrastic causatives differ in various properties, including the degree of directness between the causing event and the result state (Shibatani 1973, Cooper 1976, Comrie 1985, Dowty 1991a, Harley 2008, Jerro 2013a). In (13a), John’s causing and

the vase's breaking are construed as members of the same event, i.e. John's action directly leads to the breaking of the vase with no significant temporal gaps or intervening events. In (13b), on the other hand, it is possible that several intervening events may occur between John's causal action and the vase's result state of becoming broken. For example, suppose John left a banana peel near the vase so that someone would trip, fall into the vase, and break it. In this scenario, John's causing and the vase's breaking are conceptualized as clearly separate events. This reading is crucially unavailable with the lexical causative in (13a).

In Kinyarwanda, causative readings with the morpheme *-ish* have a direct causative reading, as in (14), compared to the periphrastic causative *tuma* in (15), which indicates indirect causation.

(14) *Umw-arimu y-a-ndik-ish-ije umw-ana in-kuru*
 1-teacher 1S-PST-write-ISH-PERF 1-child 9-story
 'The teacher made the child write the story.'

(15) *Umw-arimu ya-tum-ye umw-ana y-a-ndik-a inkuru.*
 1-teacher 1S-make-PERF 1-child 1S-PST-write-IMP 9-story
 'The teacher made the child write the story.'

Both sentences have the same general meaning of the teacher causing the child to write a story. They differ however in the degree of involvement of the teacher. In (14), the causation is direct, and the teacher is working with the child to write the story, e.g. the teacher is dictating the story or he and the child are sitting together writing the story. Temporally, the teacher's causing and the child's writing are simultaneous. This contrasts with (15), where the teacher does something (perhaps, for example, he has some kind of embarrassing accident) which inspires the child to write the story. Crucially, with the periphrastic causative the causing event and result state are not necessarily simultaneous; the causing event of the teacher behaving embarrassingly can happen on a separate day from the student's writing of the story. Other periphrastic causative verbs in the language include *gu-tegeka* 'to com-

mand/order' and *gu-saba* 'to request'. I discuss further related properties of *-ish* causatives in §3.2.

3 Applicative vs. Causative Structure

As mentioned in the introduction, one possible approach to analyzing the syncretism in Kinyarwanda is to assume that the causative and instrumental uses have separate structures, and the overlap of the two uses arises from accidental phonological merger. In this section, I entertain this view, looking at previous approaches of morphological causatives and instrumental applicatives. I show in this section that previous analyses of causatives and applicatives are not suited to the facts of the morpheme *-ish* in Kinyarwanda, even on the assumption that there are two distinct functions of the homophonous morpheme. I focus here specifically on work within the Minimalist program, as it has been the most influential in recent analyses of both applicatives and causatives. Furthermore, the core ideas I outline (and the criticisms of them) are generalizable to almost any previous approaches from a variety of frameworks. I discuss Minimalist approaches specifically with the goal of being able to explicitly outline broader problems in work on applicative and causative morphology by discussing the details of a particular framework. In §4, I then argue that not only are previous approaches not predictive of either the causative or the applicatives uses separately, but that the uses of *-ish* are in fact better suited to an analysis which treats all uses of *-ish* as outgrowths of a single operation.

3.1 Event structure and two types of applicatives

Most recent work on argument structure from a Minimalist perspective has taken a syntactified view of event structures, investigating how event structure affects where an argument gets introduced into the verb's argument structure. Work on applicatives often relies on a particular distinction between so-called 'high' and 'low' applicatives. Originally introduced

between the two structures corresponds to a semantic difference. High applicatives denote a relation between an event and an individual; low applicatives relate two individuals. This predicts that low applicatives should be unable to combine with unergative verbs since there is no thematic object to which the applied object can be related. Furthermore, because low applicatives imply a change in possession (and thereby an event of transfer), it is predicted that low applicatives should not appear with a static event nor with unaccusative verbs. Both of these predictions are borne out in English, which Pylkkänen argues has a low structure for benefactives. In (18a), the benefactive cannot be used with the unergative verb *run*, nor with the stative verb *hold* in (18b).

- (18) a. *I am running him.
 b. *I held him the bag.

Because a high applicative structure relates an individual to an eventuality, high applicatives are predicted to appear with unergative and stative verbs, such as in Luganda (Bantu, Uganda).

- (19) a. *Mukasa ya-tambu-le-dde Katonga.*
 Mukasa 3SG.PST-walk-APPL-PST Katonga
 ‘Mukasa walked for Katonga.’
 b. *Katonga ya-kwaant-i-dde Mukasa ensawo.*
 Katonga 3SG.PST-hold-APPL-PST Mukasa bag
 ‘Katonga held the bag for Mukasa.’ (Pylkkänen 2008:20,(23))

Here, the benefactive applicative appears with an unergative and a stative verb, which Pylkkänen attributes to the fact that Luganda has a high applicative structure.

One broad issue for this analysis, however, is that it does not take into consideration how particular verb meanings interact with argument realization patterns. On Pylkkänen’s account, English has low applicatives in benefactive sentences (as in (17b) above), which means that a benefactive direct object should be possible with transitive verbs. This borne

out with verbs like *buy* and *draw*, as shown in (20) and (21), where the direct object realization alternates with the oblique variant in the (a) sentences.

- (20) a. I bought the ticket for my sister.
b. I bought my sister the ticket.

- (21) a. I drew the map for Leah.
b. I drew Leah the map.

This pattern, however, is not generalizable across all transitive verbs; the direct object realization is in fact restricted to a certain set of verbs, often those denoting a specific kind of semantics, such as verbs of obtaining and some verbs of creation (Levin 1993:48-49).⁶ Many verbs, then, do not allow the direct object realization, despite allowing the indirect realization of the beneficiary; as shown in (22) – (24), the verbs *compose*, *architect*, and *liberate*, for example, do not allow the beneficiary direct object.

- (22) a. I composed a symphony for Cindy.
b. ?I composed Cindy a symphony.
- (23) a. The architect selected a house for the young couple.
b. *The architect selected the young couple a house.
- (24) a. The colonel liberated the people for the president.
b. *The colonel liberated the president the people.

While I do not pursue an analysis of these facts here, these cases are problematic for Pylkkänen's account, which incorrectly predicts that each of the (b) sentences in (22) – (24) should be grammatical given that the English low applicative is assumed to naturally appear on transitive verbs, which puts into question the generalizability of the high-low typology.⁷

⁶The grammaticality judgments of the data here are based on my ear as a native speaker of American English.

⁷A further issue is that the verbs in (22) – (24) do not in fact indicate transfer-of-possession reading, which, following Pylkkänen, is expected if they are in fact low applicatives. A solution for this would be to propose that high applicatives are present in (22) – (24), but this would still falsely predict grammaticality for the (b) sentences, since high applicatives can also appear with transitive verbs.

A more particular unresolved issue for the high-low typology is that there has been little consensus on the appropriate analysis of whether instrumental applicatives should be high or low, as instrumental applicatives have not been central to the discussion in previous works on the high-low typology. On Pylkkänen's part, she mentions briefly that she assumes that instruments pattern like high applicatives (2008:13), proposing that in a situation where someone is using an instrument to bring about an action, the instrument is in a relationship to the main event (related to the verb) but not the theme itself (another individual). Marantz (1993) makes the opposite argument: he claims that instruments are internal to the event while benefactives are external. He uses the example that when a hammer is used to drive in a nail, both the hammer and the nail are affected simultaneously (p.144). When translated into Pylkkänen's structures, this means that instrumental applicatives should be semantically low, since with low applicatives, the applied object is an argument inside the same VP as the thematic object.

McGinnis & Gerdtz (2003) also note that instruments pattern differently from beneficiaries and locational objects, and they propose a third structure in the high-low typology in order to capture the apparent mismatch between structural and semantic behavior of instrumental applicative. According to the asymmetric c-command between the instrument and applied object in Kinyarwanda, the instrumental applicative should be low; however, according to the ability to appear with intransitives like *gu-kora* 'to work' in (8), it should be high.⁸ Specifically, they propose a high applicative structure for the instrumental applicative, but one that is merged below the vP phase, as in (25).

⁸See their paper for more discussion on the c-command effects. They note that there may be transcription issues with the data they provide, so I do not reproduce the data here.

(25)

(McGinnis & Gerdts 2003:159,(14))

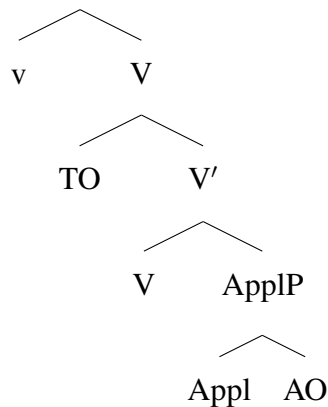

However, they only discuss one example of an intransitive verb, and the acceptability they find with the verb *gu-kora* ‘to work’ is not indicative of the larger pattern of intransitives in the language. Consider, for example, the unaccusative verbs *ku-gua* ‘to fall’ and *ku-gera* ‘to arrive’ in (26) and (27).

(26) **Karemera a-ri ku-g-ush-a i-buye.*
Karemera 1S-COP INF-fall-ISH-IMP 5-rock
‘Karemera is falling with the rock.’ (on intended reading)

(27) **Karemera ari ku-ger-esh-a i-modoka.*
Karemera 1S-COP INF-arrive-ISH-IMP 9-car
‘Karemera is arriving using the car.’

The data in (26) and (27) show that unaccusative verbs cannot appear with the instrumental use of *-ish*, which contrasts with other verbs such as unergative *gu-kora* ‘to work’ which can appear with the instrumental use of *-ish* (though note that the forms in (26) and (27) do have a causative use). Not only is this an issue for categorizing whether instrumental applicatives should be high or low, it is a problem for the theory more broadly that it cannot account for verb class variation (cf. the data in (20) – (24) in English).

To summarize, these approaches treat applicative morphemes as object-licensing structures that are merged below VoiceP and alternate in their relationship with VP depending on the semantic nature of the applicative. However, there are two issues with this analysis

in its current form: instrumental applicatives do not clearly fit into the typology, making it unclear how to situate the instrumental use of *-ish* into this typology. Furthermore, it is not obvious how to incorporate the variation of applicatives with different verb classes, which is crucial to accurately capturing the uses of *-ish*, which does not always have the full range of possible meanings with all verbs.

3.2 Causative Structure

Causatives have a long tradition in research on semantics (Fodor 1970, Smith 1970, Lewis 1973, Shibatani 1973, 1976, McCawley 1978, Dowty 1979, Ginet 1990, Bittner 1999), as well as a rich literature dedicated to the syntactic structure of morphological causatives, especially in Japanese (Kuroda 1965, Shibatani 1973, Miyagawa 1984, Kuroda 1993, Harley 1995, Manning et al. 1999, *inter alia*). Pykkänen (2008) again sets the stage for many recent discussions of causatives. For Pykkänen, *cause* is a universal head that combines with a non-causative predicate and introduces a causing event to the causal chain, with the denotation in (28).⁹

$$(28) \quad \llbracket \textit{cause} \rrbracket := \lambda P. \lambda e. (\exists e') P(e') \ \& \ \textit{cause}(e, e') \quad (\text{Pykkänen 2008:84,(9)})$$

The denotation in (28) is considered universal, combining with non-causative predicates to introduce a causing event to their semantics. In this system, variation in causative structures across languages arises from two options in the configuration of the syntax: (i) the kind of predicate selected by the cause head — i.e. a root, a VP, or a phase — as shown in (29) and (ii) whether the cause head can “bundle” with the voice head that dominates it, as in (30) where the voice and causative heads are bundled.

$$(29) \quad \text{a.} \quad \begin{array}{c} \nu_{\textit{Cause}} \mathbf{P} \\ \diagup \quad \diagdown \\ \text{Cause} \quad \sqrt{\text{Root}} \end{array} \quad \text{Root-Selecting}$$

⁹It is not clear why the existential binding of e' is enclosed in parentheses, but I reproduce it here for faithfulness to her formulation.



The different kinds of cause heads in (29) can correspond to morphological causatives (such as *-sase* in Japanese) or to so-called “zero-marked” causatives (such as with causative verbs like *close* and *fill* in English). By bundling cause to the voice head for some languages, she is able to capture that in some languages causation must introduce a new causer, while in other languages, such as in Japanese, it is possible to have causation added without a new causer, or, “non-bundled”. The differences of selection capture variation in whether the causative combines with a constituent containing an external argument (phase-selecting), VPs which lack an external argument (verb-selecting), or a sub-lexical root (root-selecting).

Despite the large amount of cross-linguistic variation that this system can in principle capture, what is not addressed is double causatives, such as the use of a morphological causative in a language like Kinyarwanda (or other Bantu languages, which she cites in her study) with lexical causative verbs. Another, related approach outlined in Harley (2008) deals with two causative heads quite directly. Harley proposes to analyze causatives as a ‘flavor’ of little-*v* head (Harley 1995, Folli & Harley 2004, 2007), which can furthermore stack in ways that derive different sorts of causatives. For example, Harley argues that for

the morphological causative *-sase* in Japanese, the matrix CAUS v_o will be separated from the root by another empty v_o head. For the Japanese causative sentence in (31a), Harley proposes the structure in (31b).

- (31) a. *Taroo-wa Hanako-ni hanasi-o tutae-sase-ta.*
 Taro-TOP Hanako-DAT story-ACC convey-CAUS-PST
 ‘Taro made Hanako convey the story.’ (Harley 2008:42,(35b))

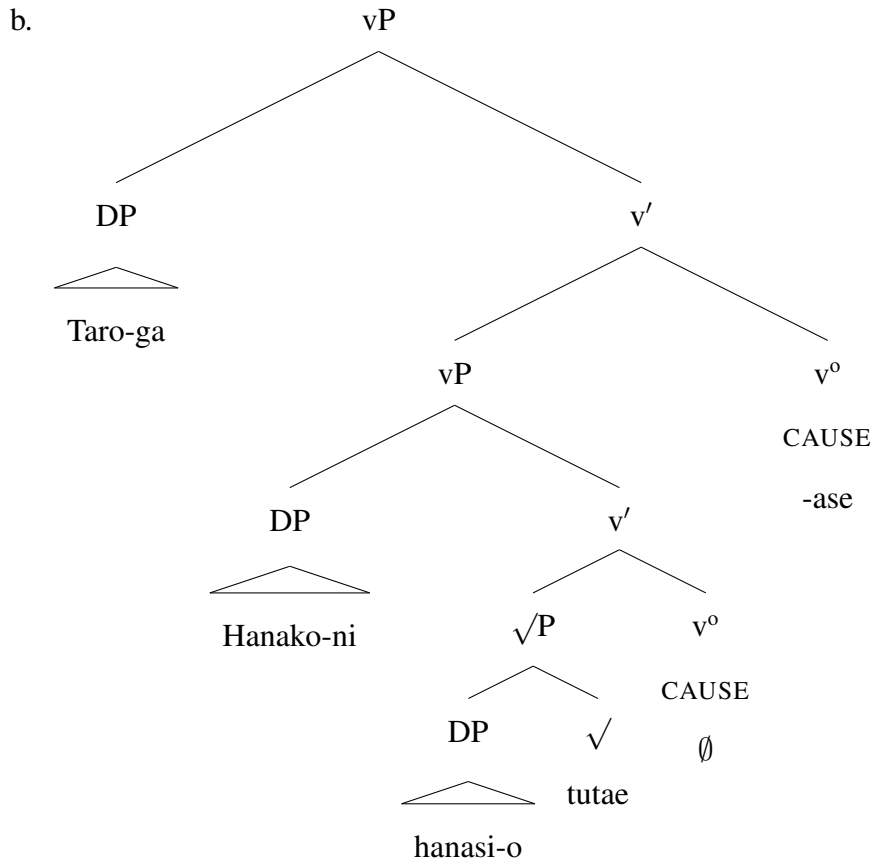

In this structure, the root *tutae* ‘convey’ moves cyclically to the two v_o heads, merging with \emptyset and *-sase*. This contrasts with the derivation of the lexical causative, where the lexical variant of *-sase* is within the same vP as the root.

- (32) a. *Taro-ga tenoura-o kae-s...*
 Taro-NOM palm-ACC return-CAUS
 ‘Taro changed his attitude suddenly’. (Harley 2008:42,(35a))

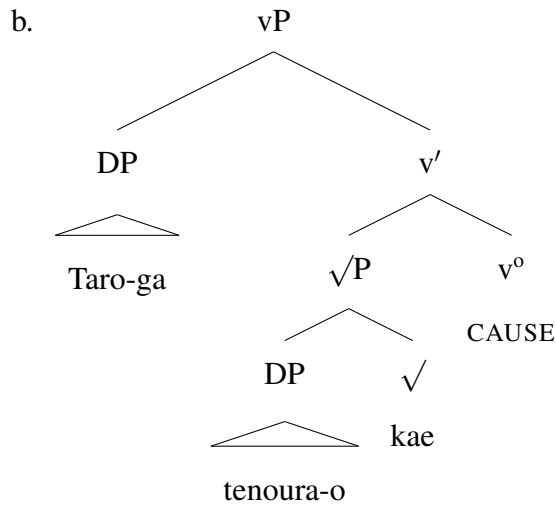

The extra structure between the root and the higher CAUS v_o in (31b) results in a periphrastic causative; the lower v_o always accompanies the root, and is interpreted as a lexical causative.¹⁰

This analysis actually predicts that all causativized transitives must pattern like periphrastic causatives. In order to causativize a transitive, there must be two CAUSE heads: the null head that is the complement to the \sqrt{P} and the higher morphological cause head that is the complement to vP . In this theory, the presence of two causative heads is correlated with periphrastic, and thus indirect, causation. The analysis for a transitive causativized verb, such as in the sentence in (33), would be the kind of structure provided in (34), where two vP shells introduce the two internal arguments.

- (33) *Umu-gabo y-ic-ish-ije umu-hungu in-zovu.*
 CL1-man CL1S-kill-ISH-PERF CL1-boy CL9-elephant
 ‘The man made the boy kill the elephant.’

¹⁰Although these analyses are not clear on how this theory would handle causativized unergatives or statives, the analysis predicts that when causativized, these verbs would have to behave as lexical causatives; these verbs presumably do not come with a causative v^o head, which means that the *-sase* morpheme will apply and be the closest head, which is predicted to be the trigger for lexical causation. Whether this prediction is borne out in Japanese is left for future research.

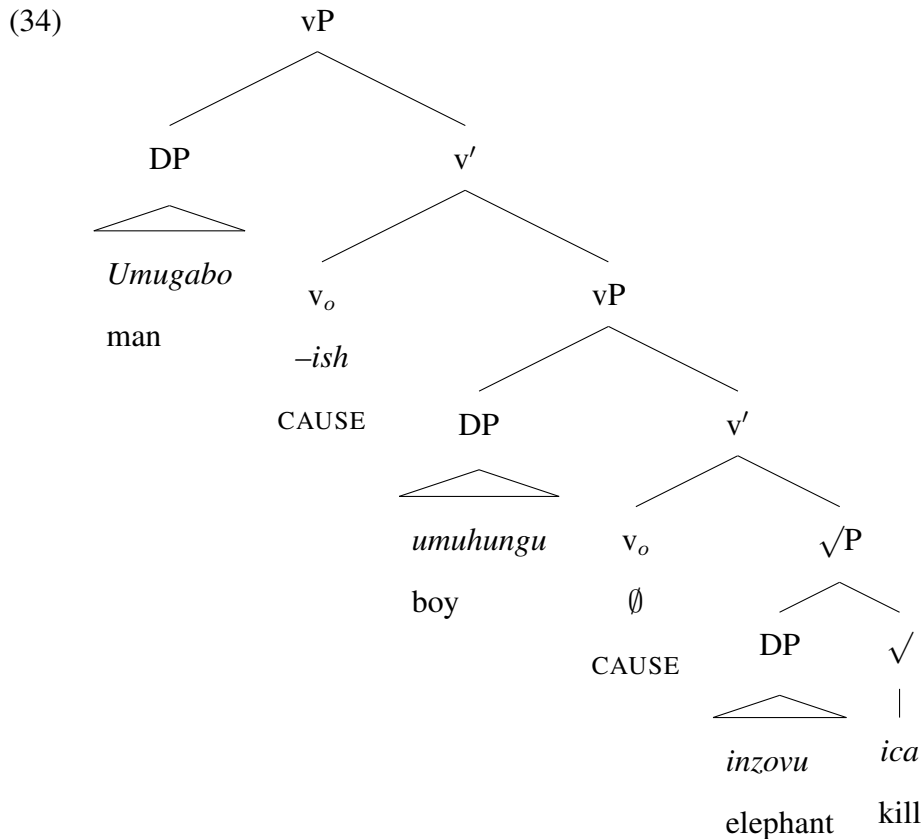

In order to capture the ditransitive structure of the sentence, it is required in this analysis that two functional heads introduce the DPs *umugabo* ‘man’ and *umuhungu* ‘boy’. The verb root *-ica* ‘kill’ would raise cyclically to the v_o heads and merge with \emptyset and *-ish*. This predicts that the morphological causative in Kinyarwanda will pattern like a periphrastic causative since there would be two vP shells over the \sqrt{P} . This is, in fact, the wrong prediction for Kinyarwanda, where the *-ish* causative patterns with lexical causatives, even when it is used with a transitive verb. Lexical causatives are known to have various properties distinct from periphrastic causatives: they generally indicate direct causation, the causing event and result state of lexical causatives are temporally indistinguishable, and they are not productive with idioms (Shibatani 1973, Cooper 1976, Dowty 1991a, Harley 2008, Jerro 2013a). Periphrastic causatives, on the other hand, are distinct in that they allow indirect causation, there can be a temporal separation of the causing event and result state, and they

are productive with idioms. Harley’s analysis predicts that *-ish* should have properties of a periphrastic causative, but I show here that causative readings of *-ish* in fact pattern with lexical causatives.

First, as noted in §2, the reading of *-ish* is necessarily one of direct causation. Second, when the morphological causative appears with temporal modifiers like *ejo hashize* ‘yesterday,’ the causing event and the result state cannot occur at separate times, as in (35).

- (35) #*Ejo hashize, umw-arimu y-a-ndik-ish-ije umw-ana in-kuru, ariko*
 Yesterday 1-teacher 1S-PST-write-ISH-PERF 1-child 9-story, but
umw-ana a-ya-ndik-a uyu mu-nsi.
 1-child 1S-9O-write-IMP 3.this 3-day
 ‘Yesterday, the teacher made the child write the story, but the child wrote it today.’

The inability for the causing event and result state to be temporally separated is a property of lexical causatives; the infelicity of (35) contrasts this with (36), where the separation of the causing event and result state is possible with the periphrastic causative *tuma*.

- (36) *Ejo hashize, umw-arimu ya-tum-ye umw-ana ya-ndik-a in-kuru, ariko*
 Yesterday 1-teacher 1S-make-PERF 1-child 1-write-IMP 9-story, but
umw-ana a-ya-ndik-a uyu mu-nsi.
 1-child 1S- 9O-write-IMP 3.this 3-day
 ‘Yesterday, the teacher made the child write the story, but the child wrote it today.’

Another test showing that the causative interpretation of *-ish* patterns with lexical causatives comes from the inability of adverbial modifiers like *incuro nyinshi* ‘many times’ to scope over just the causing event, as shown in (37).

- (37) *Umw-arimu y-a-simbuk-ish-ije umw-ana in-curo ny-inshi.*
 1-teacher 1S-PST-jump-ISH-PERF 1-child 9-time 9-many
 ‘The teacher made the child jump many times.’

#‘The teacher made, many times, the child jump.’

This contrasts with the periphrastic causative *gu-tegeka* ‘to command’, where the adverbial modifier can modify either the causing event or the result state, as in (38).

- (38) a. *Umw-arimu y-a-tegets-e umw-ana gu-simbuka in-curo ny-inshi.*
 1-teacher 1-PST-order-PERF 1-child INF-jump 9-times 9-many
 ‘The teacher ordered the child to jump many times.’
- b. *Umw-arimu y-a-tegest-e in-curo ny-inshi umw-ana gu-simbuka.*
 1-child 1S-PST-order-PERF 9-times 9-many 1-child INF-jump
 ‘The teacher ordered several times the child to jump.’

With the periphrastic causative *gu-tegeka* ‘to command’, the adverbial modifier can scope over both the causing event and the result state separately, which is not possible with the causative reading of *-ish*.

Finally, another commonly cited diagnostic for lexical causatives is whether the causative is productive with idioms. Take, for example, the idiom in (39), which literally means ‘hang the coat, but has the idiomatic meaning of ‘to die’.

- (39) *Umu-gabo y-a-zinz-e i-koti.*
 1-man 1S-PST-fold-PERF 9-coat
 ‘The man died. (lit. The man folded the coat.)’

If *-ish* were a periphrastic causative, the prediction is that the idiomatic reading should persist under causativization. This, however, is not the case: as shown in (40), the only available reading with *-ish* is the literal interpretation of the base predicate.

- (40) *Umu-gabo y-a-mu-zing-ish-ije i-koti.*
 1-man 1S-PST-1O-fold-ISH-PERF 9-coat
 ‘The man made him/her fold the coat.’ (literal)

*‘The man made him/her die.’ (idiomatic)

The idiomatic meaning is retained, however, when the verb is causativized with the periphrastic causative *tuma* ‘make’ in (41).

- (41) *Umu-gabo y-a-tum-ye umu-gore a-zing-a i-koti.*
 1-man 1S-PST-make-PERF 1-woman 1S-fold-IMP 9-coat
 ‘The man made the woman fold the coat.’ OR ‘The man made the woman die.’

In sum, the diagnostics from the directness causation, temporal overlap between the causing event and the result state, and productivity with idioms suggest that the morphological causative in Kinyarwanda patterns with lexical causatives. This is at odds with Harley's account, which predicts that causative morphology on transitives should pattern with periphrastic causatives (suited to the data she presents from Japanese).

In this section, I have considered the hypothesis that the two putatively distinct uses of *-ish* correspond to homophonous forms, and I have considered how previous analyses of causatives and applicatives could be implemented to capture the empirical nature of *-ish*. However, several issues problematized adopting any of these accounts. First, there is no transparent treatment for instrumentals in the high-low typology, as instrumental applicatives seem to show properties of both high and low structures. Furthermore, it is not clear how verb class interacts with either causative or applicative structures to rule in or out certain readings with certain verb classes. Finally, directness of causation is not naturally captured on previous accounts which would generally predict that *-ish* causatives on verbs that are lexically already causative should have a more indirect causative reading like a periphrastic causative. In the next section, I show that in addition to these independent issues related to the causative and the instrumental applicative, there is semantic, grammatical, and diachronic evidence which suggest that the uses of *-ish* are outgrowths of a single valency-changing operation.

4 Against Homophony

In the previous section, I considered previous approaches to both causative morphology and instrumental applicatives. In this section, I make a case against a homophony analysis of *-ish*. It should be noted that such a proposal has been claimed for the distantly related Bantu language Mbuun (B87; Democratic Republic of Congo), where, synchronically, both causative and (benefactive) applicative are marked by gemination of the final consonant of

the verbal root, as shown in (42).

(42) a. *Applicatives Uses*

ka-ból ‘to beat’ → *ka-bólle* ‘to beat for’

ka-kón ‘to plan’ → *ka-kóne* ‘to plant for’

b. *Causative Uses*

ka-bel ‘to boil (intr.)’ → *ka-belle* ‘to boil (tr.)’

ka-kóon ‘to lose weight’ → *ka-kóonne* ‘to make lose weight’

(Bostoen & Mundeke 2011:180,(3))

In the examples in (42), the form on the right of the arrow is derived from the root on the left, and specific lexical items idiosyncratically take causative and applicative readings (among others, such as reversive and separative). Bostoen & Mundeke (2011) provide a diachronic account that the reversive suffix **-ud* in Proto-Bantu (which has a lexically causative use in other closely related languages) and the applicative **-Id* in Proto-Bantu merged phonologically to become synchronically marked by gemination in Mbuun, concluding that the syncretism in Mbuun arises from morphophonological merger.

The diachronic and synchronic facts for Kinyarwanda, however, differ from Mbuun, and I argue that the syncretism with *-ish* is instead the result in a shift in meaning of the morphological causative **-ici* in Proto-Bantu to cover both causative and instrumental readings.

4.1 Semantic Vagueness

A homophony analysis assumes that there are two (or more) distinct senses that share phonological shape. On such a view, it is expected that the two uses are distinctly categorizable as causative and instrumental. In Kinyarwanda there are readings associated with *-ish* that are not easily distinguishable between instrumental and causative interpretations.

One such example is a dictation reading, where an animate object is manipulated to bring about an event.

- (43) *Umw-arimu y-a-ndik-ish-ije umw-ana in-kuru.*
1-teacher 1S-PST-write-ISH-PERF 1-child 9-story
'The teacher made the child write the story.'

In the sentence in (43), there are several possible interpretations, one of which is a typical causative reading where the teacher is commanding the student to write a story, and the student is creating the story on his or her own accord. Another available interpretation, however, is that the teacher is dictating a story to the child, and the child is writing down verbatim the story orated by the teacher. In this scenario, the child is being acted upon in a way that shows properties of both instruments and causees: although animate, the child is not acting volitionally in this example, functioning more in line with a prototypical instrument.

Another reading that is difficult to categorize is where the intermediary causee is a machine or robot, such as the sentence in (44). In this case, a robot is used to bring out the writing of the story, and the ambiguous level of volitionality of the robot results in neither a clear causative nor instrumental reading.

- (44) *Umu-gabo y-andik-ish-ije i-mashini in-kuru.*
1-man 1S-write-ISH-PERF 9-robot 9-story
'The man made the machine write the story.'

While in (43) there is an animate causee that is being acted on, in (44) there is an inanimate entity that is acting autonomously. In neither case is the intermediary caused entity a prototypical causee or instrument (contra e.g. Peterson 2007, who assumes that the difference between a causee and an instrument is the animacy of the caused entity). While in principle these facts are compatible with a homophony analysis, the lack of a sharp distinction puts into question the need to posit two separate forms. With a generality account, on the other hand, there is no expectation that there should be categorically distinct uses, and it

is natural that there are cases where the morpheme has readings that are not categorically causative or instrumental.¹¹ To put it another way, the semantics of the notions of causee and instrument are not very distinct and there are blurred boundaries between the two (see also Schlesinger 1989), and thus there is no clear semantic reason for treating them as two distinct but homophonous markers here.

4.2 Causative and Applicative are Syntactically Identical

Another related expectation of a homophony account is that there might be grammatical differences between the causative and instrumental uses. For example, in several languages, demoted causees of transitives are marked with oblique morphology, while applied objects are marked similarly to direct objects. As is typical of Bantu, Kinyarwanda does not have case marking on DPs (Diercks 2012), but one way to probe the grammatical properties of the two forms is the syntactic behavior of the causee and applied instrument, looking at whether the objects in applicative and causative sentences can appear in positions traditionally restricted to objects.¹² Several diagnostics used in the Bantuist literature to observe the syntax of objects include pronominal object marking on the verb (Diercks 2010, Diercks & Sikuku 2013) and passivization (Gary & Keenan 1977, Kimenyi 1980, Bresnan & Moshi 1990, Alsina & Mchombo 1993, Marten et al. 2007).¹³

First, consider the passive, which is marked morphologically after the verb stem as the suffix *-w*. The data in (45) show that the causee object and the thematic object licensed by the verb are both equally viable candidates for being subjects of a passive.

¹¹See Wechsler (2015), Chapter 2 for discussion regarding homophony and generality.

¹²It is also important to note that there is no apparent marking on the putatively demoted causee of the causative use of *-ish*. Often, the demoted causee in causative constructions is marked with some kind of distinct oblique morphology (Comrie 1989). With *-ish*, however, there is no such marking on the demoted causee.

¹³In Chapter 5 I point out several problems for these diagnostics and the assumption that putative diagnostics should follow a single point of variation. Crucially, the point here, however, is that there is no clear difference between causative and instrumental uses with respect to these diagnostics. What factors drive object symmetry is a question I address in Chapter 5.

(45) Causative Passives

- a. *Umw-ana y-a-men-esh-ej-we* *igi-kombe na mw-arimu.*
1-child 1S-PST-break-ISH-PERF-PASS 7-cup by 1-teacher
'The child was made to break the cup by the teacher.'
- b. *Igi-kombe cy-a-men-esh-ej-we* *umw-ana na mw-arimu.*
7-cup 7S-PST-break-ISH-PERF-PASS 1-child by 1-teacher
'The cup was made to be broken by the child by the teacher.'

The data in (46) show that the same situation holds for the instrumental reading; both the instrumental object and the thematic object can be subjects of a passive.

(46) Instrumental Passives

- a. *Igi-kombe cy-a-men-esh-ej-we* *in-koni na mw-ana.*
7-cup 7S-PST-break-ISH-PERF-PASS 9-stick by 1-child
'The cup was broken with a stick by the child.'
- b. *In-koni y-a-men-esh-ej-we* *igi-kombe na mw-ana.*
9-stick 9S-PST-break-ISH-PERF-PASS 7-cup by 1-child
'The stick was used to break the cup by the child.'

Another test for object status in Bantu languages is the ability for the object pronoun to incorporate onto the verb. Bantu languages vary with respect to the exact behavior of the object marker (Bresnan & Mchombo 1987, Baker 1988, Alsina & Mchombo 1993, Bax & Diercks 2012, Reidel 2007), but for many languages (including Kinyarwanda), the ability for a DP to appear as a morpheme on the verb is a sign of object status (as opposed to an oblique or secondary object which cannot, cf. Gary & Keenan 1977, Kimenyi 1980, Dryer 1983). In the causatives in (47), both the causee and the patient can be marked on the verb; similarly, both the instrument and the patient can be marked in (48).

- (47) a. *Umw-arimu y-a-mu-men-esh-eje* *igi-kombe.*
1-teacher 1S-PST-1O-break-ISH-PERF 7-cup
'The teacher made her (i.e. the child) break the cup.'

- b. *Umw-arimu y-a-ki-men-esh-eje umw-ana.*
 1-teacher 1S-PST-7O-break-ISH-PERF 1-child
 ‘The teacher made the child break it (i.e. the cup).’
- (48) a. *Umw-ana y-a-ki-men-esh-eje in-koni.*
 1-child 1S-PST-7O-break-ISH-PERF 9-stick
 ‘The child broke it (i.e. the cup) with a stick.’
- b. *Umw-ana y-a-yi-men-esh-eje igi-kombe.*
 1-child 1S-PST-9O-break-ISH-PERF 7-cup
 ‘The child broke the cup with it (i.e. the stick).’

The data from passivization and object marking are the same for both causative and instrumental uses of the morpheme, suggesting that there is no distinction in the grammatical status of the two. For some speakers, one difference between the two is the default word order (cf. Kimenyi 1980). For these speakers, the causee must come before the patient, while the instrumental object must follow it, as shown in (49) and (50).¹⁴

- (49) *Umw-arimu y-a-men-esh-eje umw-ana igi-kombe.*
 1-teacher 1S-PST-break-ISH-PERF 1-child 7-cup
 ‘The teacher made the child break the cup.’
- (50) *Umw-ana y-a-men-esh-eje igi-kombe in-koni.*
 1-child 1S-PST-break-ISH-PERF 7-cup 9-stick
 ‘The child broke the cup with a stick.’

For many Bantu languages, the animacy of the two objects has been cited as the crucial factor for determining word order (Morolong & Hyman 1972, Hyman & Duranti 1982, Aranovich 2009). The preference for the animate object to precede the inanimate object suggests that the word order differences in (49) and (50) are not due to a grammatical distinction between causative and instrumental structures, but a separate restriction on the prominence of specific arguments. In the cases just mentioned, this means that the causee will precede the theme because the causee is an animate noun.

¹⁴Though other speakers readily accept either word order with both causative and instrumental sentences.

As with semantic vagueness, the absence of any clear grammatical differences of the causative and instrumental uses is expected on an account where the two putatively distinct uses are in fact outgrowths of the same grammatical operation. While the syntactic facts are also technically compatible with the homophony approach, there is no obvious case where the causative and instrumental uses are distinct in their grammatical behavior. Furthermore, the morphological causative shows no evidence (morphologically or syntactically) of being a demoted or oblique argument, patterning exactly with the object of a monotransitive verb.

4.3 Diachronic Evidence

In this section I outline an analysis of the diachronic origins of *-ish*, which provides further evidence against a homophony account. Shibatani & Pardeshi (2002) argue from a typological perspective that causatives often extend to include applicative readings; with instrumental readings, reanalysis occurs via a ‘sociative causative’ meaning. Sociative causation is a causal relation in which the agent causes the patient to perform an action and performs the action alongside the patient. To cite their example, the Japanese lexical causative form *asoba-seru* ‘to make someone play’ describes a situation where the causer is playing with the causee, such as a caregiver and child. Semantically, the use of an instrument is parallel for Shibatani & Pardeshi (2002); an agent acting on a knife to cut bread is acting with the knife to bring about the change on the bread. Although the sociative meaning is not obligatory for causative interpretations of *-ish* synchronically, this analysis accounts for the direction of change — namely, that the causative morpheme extended to be used as the instrumental applicative, potentially via a sociative causative interpretation which served as a bridging context.

By means of comparison, many closely related Bantu languages have an applicative morpheme cognate to *-ir* which licenses several thematic object types, such as benefactive, locative, reason, and, crucially, instrumental (Wald 1998:97, Bostoen & Mundeke 2011),

and this general applicative is traceable to the Proto-Bantu applicative **-Id* (Meeussen 1967, Schadeberg 2003). The morphological causative in many languages is cognate to *-ish*, traceable to the Proto-Bantu causative morpheme **-ici* (Bastin 1986, Schadeberg 2003). The most natural analysis of the synchronic uses of the morpheme is therefore that the morphological causative extended to the instrumental applicative in Kinyarwanda, fitting with the proposal of Shibatani & Pardeshi (2002) that causative (via a sociative causative meaning) extends to cover instrumental readings.¹⁵

The use of the *-ish* as both the causative and an instrumental applicative in Kinyarwanda follows the proposed cline of grammaticalization proposed by Shibatani & Pardeshi (2002). On an account that analyzes *-ish* as an instance of accidental homophony, there is no explanation for the historical extension of the causative to the instrumental applicative.

4.4 Further Evidence

On the analysis that the causative spread to cover the instrumental applicative, it is expected that there are related languages where causees and instruments block each other — even when the two are encoded by separate morphemes. In this section, I show that this is borne out in the related language Chicheŵa (Bantu; Malawi), where the doubling of a morphological causative and instrumental applicative is prohibited.

In Chicheŵa, the instrumental applicative and morphological causative are distinct in form, being indicated by *-ir* and *-its*, respectively (Baker 1988, Alsina 1992, Alsina & Mchombo 1993, Mchombo 2004), with the instrumental applicative being the same form used for benefactive and locative applicatives. Simango (1999) observes that a causative and instrumental applicative cannot co-occur:

¹⁵This historical account does not technically rule out the possibility that in the modern language, the instrumental and causative are different morphological operations. However, the simpler analysis is that the diachronic extension of the causative to the instrumental applicative remains as a single operation in the modern language.

- (51) a. **Ulemu a-na-gw-ets-er-a mtsikana chibakera.*
 Ulemu 1S-PST-fall-CAUS-APPL-FV girl punch
 ‘Ulemu floored the girl with a punch.’
- b. **Chimwemwe a-na-d-ets-er-a mwana matope.*
 Chimwemwe 1S-PST-dirty-CAUS-APPL-FV child mud
 ‘Chimwemwe made the child dirty with mud.’ (Simango 1999:78,(14)-(15))

In both examples in (51), the simultaneous uses of a causative and instrumental morpheme is disallowed. The data in (52) show that there is also a restriction against the doubling of causatives in Chicheŵa, paralleling the restriction on doubling a causative and instrumental in (51).¹⁶

- (52) **Chikondi a-na-ndi-dy-ets-ets-a mwana chakudya chozizila.*
 Chikondi 1S-PRES-O-eat-CAUS-CAUS-FV child food cold
 ‘Chikondi made me make the child eat cold food.’ (Simango 1999:82,(22))

Simango (1999) takes this as evidence that the causative and instrumental overlap in meaning. The fact that an instrument and a causative cannot be used together suggests that causatives and instruments are treated as similar in the semantics of the language, and the restriction that prevents the doubling of causatives extends as well to the combination of instruments and causatives. The crucial point here is that despite difference in morphological form, the instrumental applicative and morphological causative in Chicheŵa overlap in their meaning, and the combination of the two is infelicitous in the same ways that the doubling of causatives is infelicitous. This supports the generalized analysis of causees and instruments having a general semantics in Kinyarwanda, which is language that is further along the path of semantic shift of the overlap of instruments and causees in that the two are synchronically marked with the same form.

A possible counter to this generalization is to argue that the doubling of all valency-adding morphology is blocked in Chicheŵa. On this view, the ungrammaticality in (51) is

¹⁶Other speakers of Chicheŵa have indicated that sentences like that in (52) are only marginally unacceptable, such as data presented in Bresnan et al. (2016:433,(14)) from judgments given by Sam Mchombo. For both speakers, however, the doubling of causatives is, to some degree, dispreferred.

not due to the semantics of instruments and causees, but rather a syntactic blocking of two valency-increasing operations. The data in (53), however, show that doubling of valency-adding morphology is in fact possible; benefactive and locative applicatives may co-occur with causative morphology.

- (53) a. *Chimwemwe a-na-phik-its-ir-a mwana dzungu.*
 Chimwemwe 1S-PST-cook-CAUS-APPL-FV child pumpkin
 ‘Chimwemwe made (someone) cook pumpkin for the child.’
- b. *Chikondi a-na-gw-ets-er-a mwana pa mchenga.*
 Chikondi 1S-PST-fall-CAUS-APPL-FV child on sand
 ‘Chikondi made the child fall on(to) the sand.’ (Simango 1999:78,(12)-(13))

The parallel ungrammaticality of causative-instrumental and causative-causative doubling in a language like Chicheŵa is independent evidence that causatives and instrumental applicatives share an overlapping semantics, even in cases where they are formally distinct.

In Kinyarwanda, we find the same inability to double causatives and instruments, as in (54), where it is not possible to have two *-ish* morphemes.

- (54) **N-a-ndik-ish-ish-ije umw-ana i-karamu in-kuru.*
 1SG-PST-write-ISH-ISH-PERF 1-child 6-pen 9-story
 ‘I made the child write the story with a pen.’

It is, however, possible to have both an *-ir* applicative and the morpheme *-ish*, as shown in (55) with the locative applicative and *-ish*.

- (55) *N-a-ndik-ish-ir-ije in-kuru mw-ana mu n-zu.*
 1SG-PST-write-ISH-APPL-PERF 9-story 1-child 18 9-house
 ‘I made the child write the story in the house.’

Thus, the incipient semantic overlap of instruments and causees in a language like Chicheŵa where the causative and instrumental applicative are formally distinct supports the analysis of Kinyarwanda as a case of historical merger between the causative and instrumental applicative.

4.5 Interim Summary

In this section I have shown that while a homophony analysis is technically compatible with the behavior of the *-ish* morpheme, a vagueness account naturally captures the overlap of the two putatively distinct uses. There is no categorical syntactic difference between the two, and there are cases where it is difficult to categorize a clear “causative” and “instrumental” reading. Furthermore, the inability to use both causative and instrumental applicative morphemes in other Bantu languages where the two are formally distinct suggests that causees and instruments overlap in their assigned thematic role, which is further evidence that the two are semantically related. Finally, the diachronic direction of change of the causative morpheme **-ici* in Proto-Bantu to cover both uses in Kinyarwanda makes accidental homophony an unlikely explanation. From this evidence, I conclude that *-ish* in Kinyarwanda has a single function that captures the variety of causative and instrumental readings.

5 Explaining the Syncretism

5.1 Theoretical Preliminaries

I propose a general semantics of causees and instruments in Kinyarwanda, analyzing the two putatively distinct functions as a single operation that introduces a novel link into the causal chain of the event structure denoted by the verb associated with the new applied object. The key insight is that this new causal link can be interpreted either as initial in the overall causal structure, deriving a causative reading, or intermediary, deriving an instrumental reading. The idea that causatives introduce a new initial causal event is of course the standard analysis, and the idea that instruments are intermediary causees has been claimed in several previous works, such as Talmy (1976), Comrie (1989), Croft (1991), Ichihashi-Nakayama (1996), Goldberg (2002), Peterson (2007), and Koenig et al. (2008). The two

different readings arise in turn from how the new causal subevent interacts with the existing events of the verb, restricted by general constraints on possible event types — and the link between lexical semantics and argument realization — that ultimately conspire to rule out one reading or another in certain cases with certain verbs.

I build on the formal analysis from Chapter 3, though in this chapter I also discuss different types of entities within the domain of eventualities U_E . I will utilize the variables v , r , s , and e' to represent subevents that are causing events and caused change of states.¹⁷ The event variable e will represent the complex event that is the summation of all subevents of the predicate, which I notate in the denotations of verbs with the subset operator (e.g. $v \subset e$ means that v is a subevent in e). In cases where a derivational morpheme adds a new subevent to a verbal predicate (such as with a causative), the subevent added by the derivational morphology will also be a subevent of the larger event e . Subevents within e are causally ordered with respect to one another. Note that causal precedence is not the same as temporal precedence, and even if one subevent causally precedes another, it is possible that the two subevents temporally overlap (even completely).

The framework outlined here is comparable to the event structural representations of the sort discussed in Chapter 2, i.e. that there is sub- event structure related to causation (and temporality). In most theories, this is represented through hierarchical organization of the event representation; I instead encode relations between causal events as constraints on the truth conditional content. While hierarchical structures are useful for capturing things like sublexical scope (see e.g. Dowty 1979), the choice of notation here is not central to the generalizations I discuss. The benefit of the framework I implement is that it provides a way of stating that causal structure is underspecified in certain verb meanings — something more difficult to state using hierarchical event structures.

Specifically, I propose that the argument introduced by *-ish* may be either the initial causer or an intermediary participant in the causal chain. Before discussing this, I first

¹⁷This means that caused changes of state are treated as events. I do not deal directly with states here.

outline one key background assumption that will be important here, namely by assuming that arguments may be reordered after the *-ish* morpheme combines with the verb. The insight for this approach comes from Zwicky (1986) and Dowty (1991b), who challenge the dominant assumption in syntactic theory that constituent structure is rigid in all languages. Dowty, for example, uses a categorial grammar with a compositional semantics in which syntactic operations are built up from words into a set of larger expressions. Crucially, the set of words is unordered, unless evidence for a specific ordering constraint is present in the language. In these cases, he adopts linear precedence principles which limit the relative ordering of specific expressions (Pollard 1984, Gazdar et al. 1985). Using this framework, he can explain several syntactic phenomena, such as the relatively free word order of Finnish and extraposition in English, without having to appeal to hierarchical syntactic structures.

As noted above in §4.2, Kinyarwanda is parallel to the Finnish data presented by Dowty in that Kinyarwanda allows scrambling in certain domains, specifically with the flexibility of ordering with multiple objects. However, rather than using a categorial grammar with linear precedence conditions, I adopt a typed lambda calculus and assume that arguments can be reordered lexically (subject to a few constraints which I discuss below), preserving the insight that arguments can in principle combine freely with the verb.¹⁸ Instead of linear precedence conditions, I assume that there are general and lexical constraints on the order of causal subevents, and these constraints in turn rule out specific orderings of arguments.

One general constraint on the possible ordering of causal elements is that the last argument to be picked up by the verb will be mapped to subject as well as assigned the role of being the initial causer in the event structure of the verb. Wunderlich (1997) proposes a similar method for subject-selection in his Lexical Decomposition Grammar, where there is a level of semantic form in which arguments are related semantically to the verb. In his

¹⁸There are in fact (at least) two ways to capture the freedom of argument order in this style of framework. One is to assume a default ordering of arguments associated with a lexical entry, and then to propose a lexical reordering operation that freely rearranges the arguments. An alternative is to assume that there is no default ordering and that arguments are lambda-abstracted in any order before the verb is handed off to the syntax. There is no empirical reason in the data presented here to favor either analysis, but for clarity of the analysis, I assume the former.

theory, argument structure relations are determined by the hierarchical position of the argument in the verb's event structure, where the highest argument in the event structure is the subject (i.e. the last to be saturated). In his event structural geometry, the initial causer is always the highest argument semantically, thus deriving the link between subjecthood and initial causers with causative verbs through prominence preservation. Adopting the notion that argument realization is tied to order of composition in the semantics, I likewise assume that the final argument to be saturated (i.e. the subject) will be the initial causer of the event (i.e. the causer participant in a causal subevent which has no preceding causal subevent), as stated in (56).

(56) **Initial Causer Realization Principle:** The subject of a caus-ative verb (in the active voice) is the initial causer of the event

One crucial difference, however, between Wunderlich's approach and the one I outline here is that Wunderlich requires that causativization always adds a higher argument. However, in order to incorporate the instrumental uses of *-ish* (i.e. those where there is an intermediary causal link), I allow that the argument introduced by *-ish* is, in principle, unrestricted in its order of composition, though verb-specific constraints on the ordering of subevents will restrict its placement. In short, the final argument to be picked up will be the initial causer, regardless of whether that argument is linked to the causal event of the verb or the causal event introduced by *-ish*.

For clarity, in the denotations below I notate the argument that is assigned to initial causer and the subevent to which it is linked with underlining. Any other arguments are mapped to objects. There has been considerable debate on the status of applied and causative object in Bantu languages, especially Kinyarwanda (Gary & Keenan 1977, Kimenyi 1980, Dryer 1983, Jerro 2015). Recall from §4.2 that both the instrumental and causative uses of the *-ish* morpheme behave like objects of monotonatives with respect to several objecthood diagnostics (such as the ability to be the subject of a passive and object-marked

on the verb). I take these diagnostics here as evidence that both of the post-verbal nouns are objects in sentences where *-ish* is used with a transitive verb. As a result, there is no difference in the grammatical status of any post-verbal DPs in the constructions discussed here.

5.2 Caused Change-of-State Verbs

Specific verb classes may enforce additional restrictions on the possible orders of causal subevents. With caused change-of-state verbs such as *write*, which include a causing subevent and a caused change of state subevent, it is required that the causing event precede the caused change of state (Dowty 1979, Rappaport Hovav & Levin 1998, Beavers & Koontz-Garboden 2013). To capture this fact, I assume a lexical constraint which states that the caused change of state s must be the final subevent in the causal chain.¹⁹ Formally, I represent this with the relation $fin'(\alpha, \beta)$ which takes two event arguments α and β and says that α is the final subevent in β .²⁰ Consider the denotation of the transitive verb *kw-andika* ‘to write’ in (57), where a writing event results in the state of some item becoming written.²¹

- (57) a. $\llbracket -andika \rrbracket := \lambda z \lambda x \lambda s \lambda v \lambda e [ag'(v, x) \wedge th'(s, z) \wedge v \subset e \wedge s \subset e \wedge writing'(v) \wedge written'(s) \wedge fin'(s, e)]$
- b. $\langle \underline{DP}_{ag} DP_{th} \rangle$

The meaning of *kw-andika* ‘write’ in (57) states that there is an event e that contains two subevents: the causing event v of writing and caused change of state s of being written. The writing event is linked to the agent participant, while the caused state is linked to the theme. The sentence in (58) provides an example of a typical use of the verb *kw-andika* ‘to

¹⁹The analysis outlined so far mirrors a standard event structural analysis as discussed in Chapter 2.

²⁰Furthermore, α may be equivalent to β in the absence of any other subevents, as discussed below.

²¹An alternative approach to restrict the ordering of causal subevents is to assume that the instrument must precede the theme by conventional implicature, as done in Rissman (2011). She argues that by introducing a new argument into the sentence (here, via the morpheme *-ish*), it is presupposed that this new argument is relevant to the description of the event (via the maxim of quantity). In the case of the *-ish* morpheme, it is implicated that the argument licensed by *-ish* is a necessary instrument for the bringing about of the caused change of state. This achieves a similar effect to the finality constraint on the caused change of state s in that both approaches derive the desired ordering of causal subevents.

write’.

- (58) *Umw-ana y-a-ndits-e in-kuru.*
1-child 1S-PST-write-PERF 9-story
‘The child wrote a story.’

The verb combines with the noun *inkuru* ‘story’ and the noun *umwana* ‘child’, which provides the denotation in (59).²²

- (59) $\exists s \exists v \exists e [\underline{ag'(v, child')} \wedge th'(s, story') \wedge v \subset e \wedge s \subset e \wedge writing'(v) \wedge written'(s) \wedge fin'(s, e)]$

The finality constraint on *s* derives the fact that *v* must causally precede *s*. For a sentence with the verb *kw-andika* ‘to write’ in (58), this means that the writing event must precede the caused state of something being written. Given the lexical restriction that the caused change of state must be final in *e*, the only available meaning is one where there is a child who is the agent of a writing event and a story that becomes written as a result, consistent also with the Initial Causer Realization Principle, which requires the subject to be the initial causer.

Recall that this analysis assumes that individual arguments can be picked up in any order, in principle allowing scrambling. This should allow the alternative ordering of arguments in (60), where the individual arguments apply in the opposite order to (57).

- (60) $\lambda x \lambda z \lambda s \lambda v \lambda e [ag'(v, x) \wedge th'(s, z) \wedge v \subset e \wedge s \subset e \wedge writing'(v) \wedge written'(s) \wedge fin'(s, e)]$

However, (60) is ruled out. With the ordering in (60), the theme is the final element to be picked up, which would map the theme to initial causer (following the Initial Causer Realization Principle in (56) which makes the argument in subject position the initial causer).

²²Recall that the underlining of a participant in the denotation indicates that that particular individual is mapped to the initial causer of the event, a purely expository device.

This is not possible due to the condition that the subject must be the participant of the initial causing event, which cannot be a theme because the theme is restricted lexically to be a participant of the final subevent of e . Thus the principle in (56) and the lexical semantics are in contradiction, making (60) an impossible denotation.

Turning to the analysis of *-ish*, I argue that the meaning of *-ish* is an operation that takes a verbal predicate as input and introduces a new argument and causal subevent e' . Recall from §3.2 that *-ish* in Kinyarwanda licenses a direct causative meaning. This fact arises naturally from the semantic categorization outlined here, where all the subevents (including the event licensed by *-ish*) are summed as part of the larger event described by the verb. The argument linked to the e' subevent introduced by *-ish* is assigned a general thematic role that subsumes both causees and instruments (Schlesinger 1989, Van Valin & Wilkins 1996, Croft 1991, Rissman 2011). I use the generalized agent thematic role (notationally: ag') as the label that subsumes agents, causers, and instruments. With these components in mind, I provide the definition of *-ish* in (61), developed from the definition of *with* in Rissman (2011). The corresponding effect of the PAS is given in (62), where the *-ish* morpheme takes some ordered set of arguments and adds a new DP.

$$(61) \quad \llbracket -ish \rrbracket := \lambda P \lambda y \lambda x_1 \dots \lambda x_n \lambda e_1 \dots \lambda e_m [P(x_1 \dots x_n, e_1 \dots e_m) \wedge \exists e' [e' \subset e_m \wedge ag'(e', y)]]$$

$$(62) \quad \langle \dots \rangle \Rightarrow \langle \dots DP_{ag_{e'}} \dots \rangle$$

The morpheme *-ish* takes an argument y and a predicate P , which may have n participants and m subevents. It introduces a new non-final subevent e' in e existentially, which is linked to a participant that has the semantic role of agent. The denotation of *-ish* in (61) composes with the denotation of the verb *kw-andika* ‘to write’ in (57) via functional application, as shown in (63), to give the denotation in (64), deriving (65) by further functional application. The resulting predicate has the PAS in (66).²³ Here the verb determines that there are two individual arguments and three event arguments; I use z , x , s , v , and e for these for

²³The subevent to which each agent argument is linked is subscripted on the thematic role label.

perspicuity.

- (63) $\lambda P \lambda y \lambda z \lambda x \lambda s \lambda v \lambda e [P(z, x, s, v, e) \wedge \exists e' [e' \subset e_m \wedge ag'(e', y)]] (\lambda z \lambda x \lambda s \lambda v \lambda e [ag'(v, x) \wedge th'(s, z) \wedge v \subset e \wedge s \subset e \wedge writing'(v) \wedge written'(s) \wedge fin'(s, e)])$
- (64) $\lambda y \lambda z \lambda x \lambda s \lambda v \lambda e [\lambda z \lambda x \lambda s \lambda v \lambda e [ag'(v, x) \wedge th'(s, z) \wedge v \subset e \wedge s \subset e \wedge writing'(v) \wedge written'(s) \wedge fin'(s, e)]] (z, x, s, v, e) \wedge \exists e' [e' \subset e_m \wedge ag'(e', y)]$
- (65) $\lambda y \lambda z \lambda x \lambda s \lambda v \lambda e [ag'(v, x) \wedge th'(s, z) \wedge v \subset e \wedge s \subset e \wedge writing'(v) \wedge written'(s) \wedge fin'(s, e) \wedge [\exists e' [e' \subset e \wedge ag'(e', y)]]]$
- (66) $\langle \underline{DP}_{ag_v}, DP_{ag_{e'}}, DP_{th} \rangle$

The meaning in (65) is the combination of *-ish* with the predicate *kw-andika* ‘to write’. Here, there are three subevents: *v*, *e'*, and *s*. *s* is the causally final subevent in *e*, but crucially *v* and *e'* are unordered causally relative to one another. Thus the actual ordering of the two can be resolved in one of two ways: *v* before *e'* or *e'* before *v*. However, constraints on argument realization — in particular the Initial Causer Realization Principle in (56), plus the possibility of reordering — ultimately determine which order arises in a given context, which I suggest captures the two readings. I discuss the instrumental reading first.

Consider the sentence in (67), where the teacher uses a pen to write a story.

- (67) *Umw-arimu y-a-ndik-ish-ije i-karamu i-karamu.*
 1-teacher 1S-PST-write-ISH-PERF 5-pen 9-story
 ‘The teacher wrote the story with a pen.’

The derivation of the sentence in (67) proceeds as in (69), with the meanings of the nouns defined in (68). The denotation in (65) first composes with *ikaramu* ‘pen’, which is the argument licensed by the *-ish* morpheme, shown in (69a). Next, the argument *inkuru* ‘story’ is composed in (69b), and finally *umwarimu* ‘teacher’ is the last argument to be picked up in (69c). The result is the denotation in (69e).²⁴

²⁴I assume that the events *s*, *v*, and *e* are existentially bound at a higher node.

- (68) a. $\llbracket ikaramu \rrbracket := pen'$
 b. $\llbracket inkuru \rrbracket := story'$
 c. $\llbracket umwarimu \rrbracket := teacher'$
- (69) a. $\lambda y \lambda z \lambda x \lambda s \lambda v \lambda e [ag'(v, x) \wedge th'(s, z) \wedge v \subset e \wedge s \subset e \wedge writing'(v) \wedge written'(s) \wedge fin'(s, e) \wedge [\exists e' [e' \subset e \wedge ag'(e', y)]]] (\llbracket ikaramu \rrbracket)$
 b. $\lambda z \lambda x \lambda s \lambda v \lambda e [ag'(v, x) \wedge th'(s, z) \wedge v \subset e \wedge s \subset e \wedge writing'(v) \wedge written'(s) \wedge fin'(s, e) \wedge [\exists e' [e' \subset e \wedge ag'(e', pen')]]] (\llbracket inkuru \rrbracket)$
 c. $\lambda x \lambda s \lambda v \lambda e [ag'(v, x) \wedge th'(s, story') \wedge v \subset e \wedge s \subset e \wedge writing'(v) \wedge written'(s) \wedge fin'(s, e) \wedge [\exists e' [e' \subset e \wedge ag'(e', pen')]]] (\llbracket umwarimu \rrbracket)$
 d. $\lambda s \lambda v \lambda e [ag'(v, teacher') \wedge th'(s, story') \wedge v \subset e \wedge s \subset e \wedge writing'(v) \wedge written'(s) \wedge fin'(s, e) \wedge [\exists e' [e' \subset e \wedge ag'(e', pen')]]]$
 e. $\exists s \exists v \exists e [ag'(v, teacher') \wedge th'(s, story') \wedge v \subset e \wedge s \subset e \wedge writing'(v) \wedge written'(s) \wedge fin'(s, e) \wedge [\exists e' [e' \subset e \wedge ag'(e', pen')]]]$

The agent linked to the writing event v is the last argument to be picked up and thus is the subject; therefore, by virtue of the Initial Causer Realization Principle, the event v associated with that argument must be the first in the causal chain of e . This ensures that the subevent e' licensed by the *-ish* morpheme (here, associated with the argument *ikaramu* ‘pen’) is causally intermediate. The reading, then, is that the teacher acts on the pen to bring about the writing event, i.e. an instrumental reading.

However, the flexibility of argument order permits an alternative, where the entity linked with the event introduced by *-ish* and the agent selected by the base verb are reordered (and with the theme now picked up first).

- (70) $\lambda z \lambda x \lambda y \lambda s \lambda v \lambda e [ag'(v, x) \wedge th'(s, z) \wedge v \subset e \wedge s \subset e \wedge writing'(v) \wedge written'(s) \wedge fin'(s, e) \wedge [\exists e' [e' \subset e \wedge ag'(e', y)]]]$

- (71) $\langle \underline{DP}_{ag_{e'}} DP_{ag_v} DP_{th} \rangle$

Here, the argument linked to e' is picked up last, and thus it must be the initial causer. This results in e' causally preceding v , both of which causally precede s . This gives rise to a classic causative interpretation, such as that in (72a), where the teacher is causing the student to write the story.

- (72) a. *Umw-arimu y-a-ndik-ish-ije in-kuru umw-ana.*
 1-teacher 1S-PST-write-ISH-PERF 9-story 1-child
 ‘The teacher caused the child to write the story.’
- b. $\exists s \exists v \exists e [ag'(v, child') \wedge th'(s, story') \wedge v \subset e \wedge s \subset e \wedge writing'(v) \wedge written'(s) \wedge fin'(s, e) \wedge [\exists e' [e' \subset e \wedge ag'(e', teacher')]]]$

In (72b), the teacher is the initial causer, meaning that he or she is the agent of a subevent which precedes the event of the student who writes the story. The finality constraint that the caused change of state s is the final subevent is satisfied; there is no event that follows s .

For clarity, let us compare the denotations in (65) and (72b). In (65), the agent of the writing event is the initial causer, meaning that the event added by the *-ish* morpheme is an intermediate event. In (72b), on the other hand, the initial causer is the argument linked to the event licensed by the *-ish* morpheme, and the agent of this event acts on the agent of the verbal causing event. The crucial difference between the two readings is whether the initial causer is the agent of the causing event denoted by the verb (i.e. the ‘writer’) or the agent of the event introduced by *-ish*.

An additional prediction of this analysis is that due to the flexibility in the ordering of participants, object word order should be free, i.e. scrambling of the two objects should be possible. Consider the order of the arguments in (73), which is nearly identical to the denotation in (70), except for the order of the x and z arguments.²⁵

²⁵For the rest of the chapter, I leave out the PAS for most derivations, as there is generally not a mismatch between the number of arguments in the syntax and the number of participants in the semantic denotations, except for in §5.1, where I discuss how implicit instrumental arguments are brought out by *-ish*.

(73) $\lambda x \lambda z \lambda y \lambda s \lambda v \lambda e [ag'(v, x) \wedge th'(s, z) \wedge v \subset e \wedge s \subset e \wedge writing'(v) \wedge written'(s) \wedge fin'(s, e) \wedge [\exists e' [e' \subset e \wedge ag'(e', y)]]]$

This ordering has the same meaning as the causative sentence in (72a), but predicts that the two objects are picked up in the opposite order, resulting in a reversal in the linear order of the objects, which is present in (74).²⁶

(74) *Umw-arimu y-a-ndik-ish-ije umw-ana in-kuru.*
 1-teacher 1S-PST-write-ISH-PERF 1-child 9-story
 ‘The teacher caused the child to write the story.’

This allows the flexibility of the order of the two objects, which is empirically borne out in Kinyarwanda.²⁷ It should be noted that due to the freedom of argument order assumed in the theory, it is technically possible for the sentence in (74) to have a derivation in which *umwana* ‘the child’ is the participant of the *s* subevent and *inkuru* ‘the story’ is linked to the *e'* subvent. This would mean something akin to ‘The teacher wrote the child with a story’. I assume that this is ruled out on pragmatic grounds as this is a highly implausible reading, though given the correct context it is technically a possible interpretation of the sentence.²⁸

There are two reorderings of participants that are always ruled out by the theory. The lexical specification *fin'* of the verb requires that the caused change of state *s* must be the final event in *e*, and thus it must be causally preceded by both *v* and *e'* (though the causal order of *v* and *e'* can vary). This rules out two possible orders: namely, those in which thematic argument *z* is the innermost participant qua the subject, i.e the denotations in (75).

(75) a. $\lambda y \lambda x \lambda z \lambda s \lambda v \lambda e [ag'(v, x) \wedge th'(s, z) \wedge v \subset e \wedge s \subset e \wedge writing'(v) \wedge written'(s) \wedge fin'(s, e) \wedge [\exists e' [e' \subset e \wedge ag'(e', y)]]]$
 b. $\lambda x \lambda y \lambda z \lambda s \lambda v \lambda e [ag'(v, x) \wedge th'(s, z) \wedge v \subset e \wedge s \subset e \wedge writing'(v) \wedge written'(s) \wedge fin'(s, e) \wedge [\exists e' [e' \subset e \wedge ag'(e', y)]]]$

²⁶Scrambling of the objects is also possible with the denotation in (65).

²⁷Though recall from above that some speakers have a weak preference for animate arguments to precede inanimate arguments.

²⁸In fact, in cases like these, speakers have joked at the risibly implausible nature of the alternative readings of sentences like (74).

The final argument to be saturated is mapped to subject and initial causer, which means that this argument cannot be the participant linked to the caused change of state s , which cannot be the initial causing event, as specified by the meaning of the verb. Any other ordering of arguments is in principle generated by the framework.

To summarize the different available orders with causative verbs, instances in which the agent participant of e' is the final argument to be picked up have e' as the initial causing event, meaning that e' causes v which in turn causes s , which must be final. This order corresponds to a causative reading. The alternative ordering is that v is the initial causer and e' is intermediary. In this ordering, the agent of e' is an instrument acted upon by the argument linked to v to bring about the caused change of state s .

5.3 *-ish* and Intransitive Verbs

I now turn to *-ish* with intransitive verbs. Recall from §2 that unergative verbs allow both the causative and instrumental readings, while unaccusative verbs do not permit the instrumental reading. I show that this follows from the causal structure of the two types of intransitive verbs. Because intransitives only have a single subevent associated in their non-applied form, I assume that in the absence of other subevents, a single subeventuality of an intransitive verb may be considered equal to the main event e by pragmatic default. , i.e. for predicates which have a single subevent (either s or v), in the absence of other subevents (e.g. when there is no valency-adding morphology used to add additional subevents to the predicate), the pragmatic default is that the single subevent of the intransitive is equivalent to the entire event e . This relation is notated formally with the symbol \subseteq (e.g. $s \subseteq e$ means that s is a subevent or equivalent to the event e). In the presence of an additional subevent (i.e. when introduced with valency-changing morphology such as *-ish*), the subevent is not equal to e .

I assume that unaccusative verbs have a single caused change of state s and unergative

verbs have a single acting event v . Furthermore, I argue that with unaccusative verbs there is a constraint that in the presence of other (derived) subevents, the caused change of state s must be final in the series of causal events as with causative verbs. With unergatives, on the other hand, there is no such restriction. These constraints I suggest conspire with the analysis of *-ish* above to produce the relevant readings. I discuss each verb class in turn, first discussing unergative verbs and then turning to unaccusatives.

Take, for example, the unergative verb *gu-kora* ‘to work’ in (76) in which the only subevent in its denotation in (77) is v , which, by default is equivalent to the main event e in the absence of another subevent.

(76) *Umu-gabo a-ri gu-kora.*
 1-man 1S-BE INF-work
 ‘The man is working.’

(77) $\llbracket -kora \rrbracket := \lambda x \lambda v \lambda e. [working'(v) \wedge ag'(v, x) \wedge v \subseteq e]$

The meaning conveyed in (77) is that there is an event of working, which has an agent participant. There is no restriction on the ordering of any subevents that are present in addition to v . Given that there is no restriction on the order of a causing event v in relation to other subevents, it is predicted that there should be both causative and instrumental readings with unergative verbs.

Consider the combination of *gu-kora* ‘to work’ with *-ish* in (78).

(78) $\lambda y \lambda x \lambda v \lambda e [working'(v) \wedge ag'(v, x) \wedge v \subseteq e \wedge \exists e' [e' \subset e \wedge ag'(e', y)]]$

With this ordering of arguments (the default), the participant of the causing event v is the final argument to be picked up, which means that this subevent is interpreted as the initial causing event. This results in an instrumental reading, with v causing e' . This is the reading of the sentence in (79), associated with the denotation in (80).

(79) *Umu-gabo y-a-kor-esh-eje i-suka.*
 1-man 1S-PST-work-ISH-PERF 5-hoe
 ‘The man is working with the hoe.’ (Overdulve 1975:(209))

$$(80) \quad \exists v \exists e [working'(v) \wedge \underline{ag'(v, man')} \wedge v \subseteq e \wedge \exists e' [e' \subset e \wedge ag'(e', hoe')]]$$

The instrumental reading arises because the agent of the working event v causally precedes the agent of the event licensed by e' . In this situation, the two subevents temporally overlap as they move forward, though the event v is what crucially causes e' . By implicature, the agent of the event licensed by e' is assumed to be involved in the action of the event v (here, working). The reading for (79), then, is that the man acts on the hoe, and the hoe is used to do the work. Note that temporally, v and e' may overlap or even be (effectively) simultaneous, though the causality is still initiated by the agent of v .

Consider now the alternative argument ordering in (81), where the y participant linked to e' is the final argument to be picked up.

$$(81) \quad \lambda x \lambda y \lambda v \lambda e [working'(v) \wedge ag'(v, x) \wedge v \subseteq e \wedge \exists e' [e' \subset e \wedge ag'(e', y)]]$$

This order corresponds to a causative reading, since the participant of e' is the final argument to be picked up, which makes the argument introduced by *-ish* the causer subject. This is the interpretation that is found with a sentence like that in (82), which has the denotation in (83).

$$(82) \quad \text{Umw-arimu } y\text{-a-kor-esh-eje} \quad \text{umw-ana.}$$

1-teacher 1S-PST-work-ISH-PERF 1-child
 ‘The teacher made the child work.’

$$(83) \quad \exists v \exists e [working'(v) \wedge ag'(v, child') \wedge v \subseteq e \wedge \exists e' [e' \subset e \wedge \underline{ag'(e', teacher')}]]$$

In (83), the subevent e' introduced by *-ish* causally precedes the subevent v of the verb *-kora*, resulting in a causative reading in (82).

With unaccusative verbs, on the other hand, I assume that in the presence of other subevents (added by morphology such as *-ish*), the caused change of state s must be the final event in the causal chain, which is formalized with the same finality condition used

with caused change of state verbs above (i.e. $fin'(s, e)$).²⁹ The intuition behind this constraint comes from restrictions on lexical verbs; it does appear to be the case that lexical verbs encode a chain of causal events where a change of state causes an action.³⁰ In fact, it is difficult to imagine what meaning such a change of state causing an action would be.

The constraint on the order of subevents predicts that the only available reading with verbs which denote a single change of state should be the causative reading. The instrumental reading is ruled out because the event e' licensed by *-ish* cannot be causally preceded by s , since s must be the final subevent in the causal chain. Consider, for example, the meaning of the verb *ku-rumbura* ‘to blossom’ in (84), which is change of state of becoming bloomed. Here, as with *gu-kora* ‘to work’, s is a subevent of e unless there are no other subevents, in which case it is interpreted as equivalent to e .

$$(84) \quad \llbracket -rumbura \rrbracket := \lambda x \lambda s \lambda e [bloomed'(s) \wedge th'(s, x) \wedge s \subseteq e \wedge fin'(s, e)]$$

The composition of the denotation of *ku-rumbura* ‘to bloom’ (84) with the *-ish* morpheme gives the denotation in (85).

$$(85) \quad \lambda y \lambda x \lambda s \lambda e [bloomed'(s) \wedge th'(s, x) \wedge s \subseteq e \wedge fin'(s, e) \wedge \exists e' [e' \subset e \wedge ag'(e', y)]]$$

The denotation in (85) corresponds to the instrumental reading, where the participant of the subevent s is the initial causer. However, this results in a violation of the finality constraint which states that s cannot causally precede any other subevent, which rules out the instrumental reading, as in (86).

$$(86) \quad \#In-dabyo \quad zi-ra-rumbur-ish-ije \quad ibi-babi \quad bya-zo.$$

10-flowers 10S-pst-bloom-ISH-PERF 8-petals 8-theirs

Intended: ‘The flowers used their petals to bloom.’

$$(87) \quad \exists s \exists e [bloom'(s) \wedge th'(s, \underline{flowers'}) \wedge s \subseteq e \wedge fin'(s, e) \wedge \exists e' [e' \subset e \wedge ag'(e', \underline{petals'})]]$$

²⁹In the absence of any other subevents, s is the only subevent, and the finality constraint is satisfied by default.

³⁰I adopt this from Rappaport Hovav & Levin (1998), who do not include changes of state causing actions in their apparently universal inventory of possible event templates.

The alternative ordering is that in (88), where *y* is instead the final argument to be saturated.

$$(88) \quad \lambda x \lambda y \lambda s \lambda e [bloomed'(s) \wedge th'(s, x) \wedge s \subseteq e \wedge fin'(s, e) \wedge \exists e' [e' \subset e \wedge ag'(e', y)]]$$

The denotation in (88) corresponds to the causative reading; because *y* is the final argument picked up, it is the initial causer and thus *e'* precedes *s*. This satisfies the finality constraint on *s* since *s* is the final subevent in the causal chain. It follows from the analysis that unaccusatives allow causative readings with *-ish*, as shown in (89), where an initial causer acts to cause the flowers to bloom.

$$(89) \quad I\text{-mana } y\text{-a-rumbur-ish-ije} \quad ibi\text{-babi.}$$

9-god 9S-PST-bloom-ISH-PERF 8-petals

‘God made the flowers bloom.’

$$(90) \quad \exists s \exists e [bloomed'(s) \wedge th'(s, flowers') \wedge s \subseteq e \wedge fin'(s, e) \wedge \exists e' [e' \subset e \wedge \underline{ag'(e', god')}]]$$

On the analysis presented here, caused changes of state are final in the causal chain, which predicts that when unaccusative verbs combine with the *-ish* morpheme the *e'* subevent must causally precede the event described on the verb. This is borne out, capturing the data in (86) and (89), where the instrumental reading is ruled out with unaccusative verbs.

5.4 Implicit Instruments

So far, these cases of *-ish* have involved wholesale addition of a new participant into a verb’s argument structure both syntactically and semantically, where the interaction with verb meaning has served to rule in or out certain readings. However, in chapter 3 I argued that with certain verbs, participants that are already part of the meaning of the verb but which are not realized syntactically are brought out via the locative applicative. This was shown with various verbs of directed motion, such as *kw-ambuka* ‘to cross’ and *kw-injira* ‘to enter’, where the locative applicative licenses a compatible (i.e. subtype of locative) argument, such as a source, goal, or route.

So far, the current chapter has provided an analysis of the syncretic morpheme *-ish*, and from the case presented in the last chapter with respect to the applicatives licensing syntactically unrealized participants of the verb, we might hypothesize that in the right context, *-ish* may interact in a similar way as *-ir* does with the directed motion verbs discussed in Chapter 3. However, the interaction in this case would be between the subevent of the *-ish* morpheme and an unrealized causal event in the meaning of a particular verb. I propose in this section that this possibility is attested: when *-ish* is composed with verbs which entail the use of an instrument, an unrealized instrument participant is licensed overtly via the *-ish* morpheme.

There is a specific class of verbs which obligatorily requires the use of an instrument, such as the English verbs *cut*, *amputate*, *dissect*, *guillotine*, *cleave*, and *sever* (Koenig et al. 2008). Consider the meaning of the verb *cut* in English, where a successful cutting event is entailed to be mediated by the use of some kind of instrument, such as a knife or scissors. These verbs are distinct from verbs like *break* or *eat*, where use of an instrument is possible but not required. With obligatory instrument verbs, the instrument is entailed to exist even if that participant is not realized as a syntactic dependent. For example, it is felicitous to say either sentence in (91), though the use of an instrument is assumed even when it is absent from the syntax, as in (91b).

- (91) a. Joel cut the bread with a knife.
b. Joel cut the bread.

For cases where *-ish* is used with an obligatory instrument verb like *cut*, I propose that the participant of the intermediary subevent and the subevent introduced by *-ish* is the same, which has the effect of *-ish* licensing an implicit instrumental argument that is not licensed by the base verb.

Take, for example, the denotation of the verb *gu-kata* ‘to cut’ in (92). As above for motion verbs such as *kw-ambuka* ‘to cross’, I assume that there are three semantic partici-

pants: an agent, an intermediary instrument, and a theme. Furthermore, I assume that there is an additional subevent r which is linked to the instrumental participant. As with other caused change of state verbs (such as *kw-andika* ‘to cut’ above), the caused change of state s must be final in the causal chain. Additionally, the verb *gu-kata* ‘to cut’ idiosyncratically requires that the causing event v must precede the (instrumental) subevent r , which in turn — given the finality constraint on caused changes of state — must precede s . The intuition is that since these verbs are inherently instrumental, they must encode a more elaborated causal structure than verbs that take instruments and causees only due to *-ish* marking. This captures the fact that this verb implicates a causer acting on an instrument to bring about some change of state of the theme. I formally represent the causal precedence of v before r with the relation *init'*, which parallels the relation *fin'* above; namely, *init'*(α, β) takes two event arguments α and β and says that α is the initial subevent in β . With these components in mind, consider the meaning of the verb *gu-kata* ‘to cut’, with the PAS in (93).

$$(92) \quad \llbracket -kata \rrbracket := \lambda z \lambda y \lambda x \lambda s \lambda r \lambda v \lambda e [ag'(v, x) \wedge ag'(r, z) \wedge th'(s, y) \wedge v \subset e \wedge s \subset e \wedge r \subset e \wedge cutting'(v) \wedge cut'(s) \wedge init'(v, e) \wedge fin'(s, e)]$$

$$(93) \quad \langle \underline{DP}_{ag} DP_{th} \rangle$$

As with the motion verbs in Chapter 3, note that there are only two syntactic arguments in the PAS of the verb, indicating that a mismatch between the number of syntactic argument positions and the number of semantic participants. Following the analysis presented in Chapter 3, I propose that the outermost argument is existentially bound prior to insertion in the syntax in cases where there are more semantic participants than syntactic argument positions.

Consider a sentence with the non-applied variant of the verb *gu-kata* ‘to cut’, such as that in (94), where the participant z in (92) is existentially bound.

(94) *Umu-gabo y-a-kas-e igi-ti.*
 1-man 1S-PST-cut-PERF 7-tree
 ‘The man cut the tree.’

(95) $\exists s \exists r \exists v \exists e \exists z [ag'(v, man') \wedge ag'(r, z) \wedge th'(s, tree') \wedge v \subset e \wedge s \subset e \wedge r \subset e \wedge$
 $cutting'(v) \wedge cut'(s) \wedge init'(v, e) \wedge fin'(s, e)]$

In (95a), the intermediary participant is existentially bound in order to resolve the mismatch between the argument structure and the number of participants in the semantics.³¹

I propose a nuanced meaning of *-ish* for this particular class of verbs where there is no new participant added by the use of *-ish* equivalent to the non-semantic argument adding use of *-ir* in Chapter 3. Instead, the argument linked to e' is the outermost participant of the base verb (formally represented as x_1).

(96) $\llbracket -ish \rrbracket := \lambda P \lambda x_1 \dots \lambda x_n \lambda e_1 \dots \lambda e_m [P(x_1 \dots x_n, e_1 \dots e_m) \wedge \exists e' [e' \subset e_m \wedge ag'(e', x_1)]]$

In (96), a new subevent e' is introduced into the causal chain of the verb, but the participant linked to e' is the first argument of the verb to which *-ish* attaches instead of a new participant licensed by *-ish*.

When the meaning in (92) composes with the meaning of *-ish* in (96), the result is the denotation in (97), where there are three syntactic arguments that are mapped to four subevents: the causing event, the caused change of state, and the event e' introduced by *-ish*. The intermediary argument z is linked to the subevent r as well as e' .

(97) $\lambda z \lambda y \lambda x \lambda s \lambda r \lambda v \lambda e [ag'(v, x) \wedge ag'(r, z) \wedge th'(s, y) \wedge v \subset e \wedge s \subset e \wedge r \subset e \wedge$
 $cutting'(v) \wedge cut'(s) \wedge init'(v, e) \wedge fin'(s, e) \wedge \exists e' [e' \subset e \wedge ag'(e', z)]]$

In (97), the outermost argument z is both the agent of the intermediary event r as well as the participant linked to the subevent e' . I take the linking of the same participant to two separate subevents to indicate that the two subevents are treated as the same subevent in the causal chain. This has the effect of e' always being interpreted as the intermediary subevent

³¹The variable r is existentially bound in a higher node in the derivation, as I have assumed for all event variables.

r with instrument verbs. Thus, it is predicted that with these verbs, *-ish* has an obligatorily instrumental reading, which is borne out in (98) with the verb *gu-kata* ‘to cut’.

- (98) *Umu-silikari y-a-kat-ish-ije umu-horo igi-ti.*
 1-soldier 1S-PST-cut-ISH-PERF 3-machete 7-tree
 ‘The soldier cut the tree with a machete.’

- (99) $\exists s \exists r \exists v \exists e [ag'(v, soldier') \wedge ag'(r, machete') \wedge th'(s, tree') \wedge v \subset e \wedge s \subset e \wedge r \subset e \wedge cutting'(v) \wedge cut'(s) \wedge init'(v, e) \wedge fin'(s, e) \wedge \exists e' [e' \subset e \wedge ag'(e', machete')]]$

In (98), the initial causer is the soldier, which is the last participant to be picked up. The restriction on v to precede r is satisfied, as the participant *umuhoro* ‘machete’ (linked to both r and e') is not the initial causer, and therefore, it is intermediary in the causal chain.

Consider an alternative ordering of the arguments, where z is the last argument to be picked up and thus interpreted as the initial causer.

- (100) $\lambda x \lambda y \lambda z \lambda s \lambda r \lambda v \lambda e [ag'(v, x) \wedge ag'(r, z) \wedge th'(s, y) \wedge v \subset e \wedge s \subset e \wedge r \subset e \wedge cutting'(v) \wedge cut'(s) \wedge init'(v, e) \wedge fin'(s, e) \wedge \exists e' [e' \subset e \wedge ag'(e', z)]]$

Such a denotation, however, is ruled out: given the constraint that v causally precedes r , it is not permissible for z to be the initial causer; z cannot simultaneously be the initial causer as well as the participant linked to an intermediary causal event. This means that the causative reading of *-ish* with the verb *gu-kata* ‘to cut’ should be ruled out, which is borne out in (101).

- (101) #*Umu-silikari y-a-kat-ish-ije umw-ana igi-ti.*
 1-soldier 1S-PST-cut-ISH-PERF 1-child 7-tree
 Intended: ‘The soldier made the child cut the tree.’

- (102) $\exists s \exists r \exists v \exists e [ag'(v, child') \wedge ag'(r, soldier') \wedge th'(s, tree') \wedge v \subset e \wedge s \subset e \wedge r \subset e \wedge cutting'(v) \wedge cut'(s) \wedge init'(v, e) \wedge fin'(s, e) \wedge \exists e' [e' \subset e \wedge ag'(e', soldier')]]$

Given the restriction on the order of events specified by the verb *gu-kata* ‘cut’, the causative

reading is ruled out for these verbs.³²

6 Conclusion

In this chapter, I have shown that syncretic morphology between morphological causatives and instrumental applicatives, such as *-ish* in Kinyarwanda, poses a theoretical puzzle for traditional analyses of causatives and applicatives. Arguing against homophony, I propose that the two putatively distinct uses of the morpheme in fact derive from a single operation in which a new causal subevent and argument are added to the argument structure of a verb. The different readings derive from general constraints on possible event types as well as verb-specific constraints on the ordering of subevents.

This analysis not only provides an explanation for the presence of syncretic causative-applicative morphology (and, ideally, in other syncretic systems), but also highlights the import of underlying verbal meaning in argument realization, enriching the generalizations of morphemes previously thought to be restricted to the domain of syntax.

³²Similar to the case above in (73) – (74), it is also possible to scramble the order of the objects with the verbs which entail an instrument.

Chapter 5: The Syntax and Semantics of Object Symmetry

1 Introduction

The literature on applied objects in Bantu languages has focused almost exclusively on the syntactic behavior of the applied object in relation to the object licensed by the transitive verb. Several differing — and at times contradictory — conclusions have been drawn regarding the nature of object symmetry due in part to different authors positing generalizations derived from different areas of object symmetry syntax. Furthermore, certain semantic effects have not been taken into account with the investigation of object symmetry, leaving empirical gaps and confounds within previous generalizations.

A recurring claim in the literature has been that the thematic role of the applied object (e.g. locative, benefactive, instrumental) determines specific patterns of symmetry or asymmetry. In this chapter I argue that there is no universal connection between thematic role and any specific syntactic structure, and, therefore, no universal correlation between thematic role and a specific symmetry pattern. As I elaborate in more detail below, this position is essentially the null hypothesis: since any syntactic configuration could in principle be associated with any semantics, there is no particular reason to assume that semantic role should universally determine object symmetry. On this perspective, it is expected that languages should vary in the kinds of symmetry found with different thematic roles. I show here that this is indeed the case, and from the previously published and original data presented here, it emerges that the degree to which thematic role affects symmetry properties, it does not universally capture the variation across languages. Furthermore, from the relevant data I also suggest that a mixture of other factors might be implicated in determining object symmetry, including animacy of the relevant NPs, information structure, and possibly even verb class, among others. As with thematic role type, these factors also do not have a universal effect on symmetry, but are relevant in different ways in different

languages, and often interact with one another.

Furthermore, previous approaches have tacitly assumed or explicitly claimed that various objecthood traits (e.g. being the subject of a passive, pronominal object marking on the verb, etc.) should follow uniformly from the syntactic structure of the applicative, attempting to reduce the variation to as few parameters as possible (and, ideally, just one). However, there is no necessary reason that there must exist a universal structure of putative symmetric and asymmetric applicatives. In fact, empirically, specific object diagnostics vary across languages and thematic object type, making it unlikely that there is a single uniform source of object symmetry diagnostics, which further suggests a lack of overall universality. In what follows, I do not attempt a detailed analysis of all components of symmetry in each of the languages under discussion, but rather, I intend to make a case against the pervasive assumption that object symmetry follows from some universal structure.

This chapter proceeds as follows. In the next section I give a critical overview of previous approaches to object symmetry, which have nearly all proceeded on the assumption that thematic role correlates with a specific pattern of object symmetry. In this section it is already clear from previously published data that it is problematic to make generalizations about symmetry across languages or thematic roles, as contradictory patterns are cited in different places in the literature. In section 3 I provide original comparative data from three languages collected specifically with the goal of holding potentially confounding factors constant in comparing the symmetry properties across languages. I show in this section that symmetry patterns differ across thematic roles in different languages as well as with different diagnostics. I also point to other grammatical markers (such as resumptive pronouns and oblique marking) which are often obligatory when an applicative is used in a particular syntactic structure, which further complicates the picture of what it means for a language to be symmetrical. Section 4 provides tentative evidence from Lubukusu caused ingestive verbs that the semantic class of the base verb may be one of the factors relevant

for determining the symmetry of objects, building on the larger point of the thesis that semantic verb class affects the syntax of argument realization. I conclude the discussion in Section 5.

2 The syntax of symmetry

In this section, I provide a review of the literature on object symmetry, starting with early work from Relational Grammar and Government-Binding theories to the current trend of using high and low applicative structures to derive symmetry. I group the discussion into three sections: first, I discuss the earliest approaches to object symmetry within the generative tradition, where the focus was on making generalizations about how particular languages treated symmetry, often assuming homogeneity of different applied objects' symmetry properties. I then move to analyses that focus on how different thematic roles correlate with distinct symmetry patterns, deriving symmetry from universal properties of either syntax or thematic role type. In the final section, I discuss recent approaches from the Minimalist program, which explains symmetry in terms of where a specific head is merged into the syntax. As I discuss these different approaches, I offer critical discussion, hinting at issues that I address with the cross-linguistic study I present in §3.

2.1 Early Approaches to Symmetry

The first wave of generative work on object symmetry started in the late 1970s, analyzing applicativization as an operation which promotes an oblique to a full object (Gary & Keenan 1977, Kisseberth & Abasheikh 1977, Dryer 1983, Perlmutter & Postal 1983, Kinyenyi 1980).¹ For example, consider the following data from Kinyarwanda, where both objects of the applied verb in (1) can be subjects of the passive, as in (2a-b).

¹The perspective that applicatives are incorporated pronouns perseveres in works like Baker (1988) and Jeong (2007).

- (1) *Umu-gabo a-ra-ndik-ir-a umw-ana in-kuru.*
 1-man 1S-PRES-write-APPL-IMP 1-child 9-story
 ‘The man is writing the story for the child.’
- (2) a. *Umw-ana a-ra-ndik-ir-w-a in-kuru (n’ umu-gabo).*
 1-child 1S-PRES-write-APPL-PASS-IMP 9-story by 1-man
 ‘The child is being written the story (by the man).’
- b. *In-kuru i-ra-ndik-ir-w-a umw-ana (n’ umu-gabo).*
 9-story 9S-PRES-write-APPL-PASS-IMP 1-child by 1-man
 ‘The story is being written for the child (by the man).’ (Kinyarwanda)

From data such as that in (2), it has been claimed that there is no grammatical distinction between the applied and thematic objects (Gary & Keenan 1977).

Already in early work, however, it was argued that languages varied in the behavior of applicatives. Other languages differ from Kinyarwanda in that the two objects do not share the same syntactic behavior, and it was claimed that there is indeed a distinction between applied and thematic objects.² It was proposed that in these cases applicativization put the thematic object *en chômeage*, a special grammatical relation proposed in Relational Grammar for objects that have been demoted from full object status (Kisseberth & Abasheikh 1977). The *chômeur* is no longer able to undergo objecthood operations such as raising in passivization, which results in object asymmetry. Chimwi:ni is such a language; in (4b), the thematic object is unable to be the subject of a passive, while in (4a), the beneficiary is.³

- (3) *Hamadi ∅-wa-pik-il-ile wa:ana cha:kuja.*
 Hamadi sm-om-cook-APPL-FV children food
 ‘Hamadi cooked food.’ (Chimwi:ni: Kisseberth & Abasheikh 1977:188,(27b))
- (4) a. *Wa:na wa-pik-il-ila cha:kuja na Hamadi.*
 children SM-cook-APPL-FV food by Hamadi
 ‘The children had food cooked for them by Hamadi.’

²In fact, it was later argued that there are in fact instances in Kinyarwanda that necessitate a distinction between grammatical functions of applied and thematic objects (Dryer 1983).

³The glosses in the original data leave out much desired information about the verbal morphology. In particular, there is no glossing of passive morphology.

- b. **Cha:kuja sh-pik-il-ila wa:na na Hamadi.*
 food SM-cook-APPL-FV children by Hamadi
 ‘The food was cooked for the children by Hamadi.’

(Chimwi:ni; Kisseberth & Abasheikh 1977:189,(31-32))

The data in (4) indicate an asymmetry between the thematic object and the beneficiary applied object in the (in)ability to be the subject of a passive. Crucially, the thematic object *can* be raised in passivization in a non-applied predicate, as in (5), where the thematic object is the subject of the passivized transitive verb *pika* ‘cook’.

- (5) a. *Hamadi ∅-sh-pishile cha:kuja.*
 Hamadi SM-OM-cook food
 ‘Hamadi cooked the food.’
- b. *Cha:kuja sh-pishila na Hamadi*
 food SM-cook by Hamadi
 ‘The food was cooked by Hamadi.’

(Chimwi:ni; Kisseberth & Abasheikh 1977:188,(28-29))

The data in (2) – (5) indicate cross-linguistic variation in the objecthood of the thematic object. In Kinyarwanda, the thematic object can be the subject of a passive sentence even in the presence of the applied object; in Chimwi:ni, the thematic object in an applied predicate cannot, losing the object status that it has in a monotransitive sentence.⁴

Bresnan & Moshi (1990), in an attempt to tackle variation of applicative behavior across languages, propose the Asymmetric Object Parameter, a parameter of variation in which certain languages have a constraint which prohibits two arguments from having the object grammatical function. In the terminology of the Lexical Mapping Theory which they use, the constraint is that only one theta role can be intrinsically classified with the feature [–*r*], a feature in the theory reserved for arguments which are unrestricted (i.e. arguments which can appear as a subject or object). This has the result of an asymmetry between

⁴Other diagnostics for object status include whether each object can be pronominalized on the verb, be relativized out of object position, or be reflexively linked to the subject. I return to the different symmetry diagnostics below.

the applied and thematic objects since only the applied object is unrestricted (e.g. able to be the subject of a passive). Other languages lack the restriction on the number of roles that may be assigned the $[-r]$ feature, permitting that two roles may simultaneously be intrinsically classified with the $[-r]$ feature. These latter languages are those where there is object symmetry and both the thematic and applied objects can be subjects of passives, extracted in relative clause formation, etc.⁵

However, there is considerably more variation in symmetry patterns among different thematic types of applicative within a single language than can be captured by a single parameter, as shown in detail in §3. For example, Baker (1988) and Alsina & Mchombo (1990) show that there is a difference in object marking between the benefactive applicative and instrumental applicative in Chicheŵa.⁶ In (7a), the applied object of the benefactive applicative⁷ can appear as an object marker, while in (7b), the thematic object cannot.⁸

- (6) *M-lenji a-na-dul-ir-a mw-ana m-tengo.*
 1-hunter 1S-PST-cut-APPL-IMP 1-child 3-tree
 ‘The hunter cut the child’s tree.’
- (7) a. *M-lenji a-na-mu-dul-ir-a m-tengo.*
 1-hunter 1S-PST-1O-cut-APPL-IMP 3-tree
 ‘The hunter cut someone’s tree.’
- b. **M-lenji a-na-u-dul-ir-a mw-ana.*
 1-hunter 1S-PST-3O-cut-APPL-IMP 1-child
 ‘The hunter cut something belonging to the child.’

In (8a-b), however, both the thematic object and the instrumental applied object may each appear as object markers on the verb with the instrumental applicative.

⁵To their credit, Bresnan and Moshi focus solely on the nature of the benefactive applicative between their two types of languages; in effect, what their study shows is that languages differ in whether the benefactive applicative is symmetrical or asymmetrical, which does fit with the data I present below. See Jerro (2015) for a proposal on how to extend their claim to capture language-internal variation.

⁶The data I present here come from my own interviews with speakers of Chicheŵa. I discuss Baker’s and Alsina and Mchombo’s analyses in turn in the next section. Bresnan and Moshi do acknowledge this variation, citing Alsina and Mchombo’s analysis of Chicheŵa.

⁷In many instances, the benefactive applicative takes a possessive reading, where the theme is interpreted as belonging to the beneficiary (or maleficiary, as the case may be).

⁸There is extensive work on the morphosyntax of object markers in Bantu in their own right (Bresnan & Mchombo 1987, von Heusinger 2002, Buell 2006, Henderson 2006, Adams 2010, Diercks & Sikuku 2011, Baker et al. 2012, Marlo 2014, 2015), but regardless of the exact analysis, the ability to appear as an object marker is often used as a canonical diagnostic of object status (Gary & Keenan 1977, Baker 1988, Bresnan & Moshi 1990, Alsina & Mchombo 1993, *inter alia*).

- (8) a. *A-mayi a-na-u-phwany-ir-a ndodo.*
 2-mother 2S-PST-3O-break-APPL-FV stick
 ‘Mother broke it with a stick.’
- b. *A-mayi a-na-i-phwany-ir-a m-phika.*
 2-mother 2S-PST-7O-break-APPL-IMP 3-pot
 ‘Mother broke the pot with it.’

In (7), there is an asymmetry between the beneficiary applied object and the thematic object, while in (8), the instrumental applied object and the thematic object are symmetrical. This variation in symmetry behavior with benefactive and instrumental applicatives is evidence that symmetry is not broadly parameterizable from language to language, but rather whether the thematic object is an object in each language must be considered in its own right (this was in fact noted previously by Baker 1988 and Alsina & Mchombo 1993; see the next subsection).

2.2 Thematic Role and Object Symmetry

Since Bresnan & Moshi (1990), the focus of research on applicatives has moved away from the cross-linguistic patterns of symmetry, and most work instead has focused on the behavior of specific thematic roles of applied objects within an individual language. Two questions have been at the center of the mainstay of research on applicatives: (i) what are applied object roles in a language that correlate with symmetrical or asymmetrical behavior, and (ii) how can the observed patterns be derived from general syntactic principles?

Various explanations have been used to derive the empirical facts of different languages, going back to Baker (1988), who argues that the differences in the symmetry patterns of different thematic roles corresponds to configurational differences in the assignment of Case. Comparing instrumental and benefactive applicatives, Baker argues that instrumental applied objects are directly assigned inherent Case by the verb, while benefactive applied objects receive structural Case from a null preposition. Due to being assigned structural

Case, there are two predictions about beneficiary applied objects. First, arguments which receive structural Case must precede those which receive inherent Case. Furthermore, on the assumption that object-marked objects on the verb are only permitted to arguments checked for structural Case, it is predicted that the beneficiary can be object marked, while the thematic object (which gets inherent Case) remains as a post-verbal object. The reverse, however, is not possible since the beneficiary object does not get inherent Case. With instrumental applicatives, either the instrumental object or the thematic object may receive inherent Case, so word order is predicted to be free, and either (but not both) is permitted to be object-marked on the verb.

However, there are various issues with this approach, and many of these issues persist in other accounts of object symmetry. I mention three of these issues here, not necessarily with the intent of belaboring the empirical inaccuracies of Baker's account, but rather to illustrate two flawed assumptions that broadly problematize nearly every other account on the market: first, that object symmetry diagnostics should all follow from the same point of variation, and second, that thematic roles are linked to syntactic structure, which means that the meaning of an applicative is tied to whether it will be symmetric or asymmetric. Baker's analysis remains one of the most clearly articulated accounts of object symmetry in a specific language, which makes it the clearest case for outlining problems that have underlain most previous work on symmetry.

The first issue is mentioned by Baker himself: on his analysis it is predicted that instrumental applicatives should be symmetrical under passivization. Baker assumes that the passive morpheme absorbs the verb's ability to assign structural Case, which predicts that one of the two objects must raise to get nominative Case, and the other object is assigned inherent Case and left *in situ*. With the benefactive, the theme has inherent Case, thus only the benefactive is predicted to raise to subject; with instrumental applicatives, on the other hand, either object can be assigned inherent Case, predicting that either should be able to

raise to subject of a passive. This, however, is not borne out; only the instrumental object can be the subject of a passive verb, as shown in (9b).

- (9) a. **Kapu li-na-phwany-ir-idw-a ndodo.*
 cup S-PST-break-APPL-PASS-FV stick
 ‘The cup was broken with a stick.’
- b. *Ndodo u-na-phwany-ir-idw-a kapu.*
 stick 3S-PST-break-APPL-PASS-FV cup
 ‘The stick was used to break the cup.’

Baker acknowledges that his theory incorrectly predicts symmetry with passivization of instrumental applicatives.

A second issue was raised by Alsina & Mchombo (1990), who show that Baker’s account incorrectly predicts that beneficiary applicatives should not be formed on intransitives. Baker originally showed that with pairs of verbs with intransitive and transitive counterparts, the benefactive can only appear with the transitive use, while the instrumental can appear with either.

- (10) *mlēnje a-ku-lémb-ér-a mfúmú *(chimangirīzo).*
 1-hunter 1S-PRES-write-APPL-FV 9-chief 7-essay
 ‘The hunter is writing for the chief.’ (Alsina & Mchombo 1990:500,(12a))

- (11) *mlēnje a-ku-lémb-ér-a nthēnga (chimangirīzo).*
 1-hunter 1S-PST-write-APPL-FV 2-children 7-essay
 ‘The hunter is writing (an essay) with a feather.’

(Alsina & Mchombo 1990:500,(13a))

In (10), the beneficiary object can only appear when the thematic object is also present; in (11), the instrumental applicative can appear with either the transitive or intransitive uses. This is predicted by Baker’s analysis on the assumption that intransitive verbs do not assign structural Case. Because the beneficiary object can only receive structural Case, it follows that benefactive applicatives should not be permitted with intransitive verbs. Alsina

& Mchombo (1990), however, show that Baker erroneously conflates intransitive verbs and verbs that permit object deletion, and they present data — repeated in (12) and (13) — that show that beneficiaries can in fact appear on intransitives.

(12) *Yêsu a-ná-wá-f-er-a (anthu).*
 1-Jesus 1S-PST-2O-die-APPL-FV 2-people
 ‘Jesus died for them (the people).’

(13) *Ānthu a-ná-f-ér-ědw-a (ndí Yêsu).*
 2-people 2S-PST-die-APPL-PASS-FV by 1-Jesus
 ‘The people were died for (by Jesus).’ (Alsina & Mchombo 1990:502,(17))

The data in (12) and (13) are unaccounted for on Baker’s analysis.⁹ Furthermore, given that Baker’s approach assumes that intransitive verbs can only assign inherent Case, it is predicted that instrumental applicatives on intransitive verbs should not take object makers nor should the instrumental object be the subject of a passive, since object marking and passivization are assumed to be sensitive to structural Case. This, however, is incorrectly ruled out, as shown in (15a-b), where the instrumental applied object of an intransitive can be the subject of a passive and object-marked on the verb.

(14) *Anyăni a-na-yénd-ér-a ndōdo.*
 2-baboons 2S-PST-walk-APPL-FV 9-stick
 ‘The baboons are walking with a stick.’

(15) a. *Anyăni a-na-í-yénd-ěr-a (ndōdo).*
 2-baboons 2S-PST-9O-walk-APPL-FV 9-stick
 ‘The baboons are walking with it (the stick).’

b. *Ndōdo i-na-yénd-ér-ědw-a (ndí anyăni).*
 9-stick 9S-PST-walk-APPL-PASS-FV by 2-baboons
 ‘The stick was walked with (by the baboons).’

(Alsina & Mchombo 1990:503,(18))

⁹Baker does note that sentences of the type in (12) and (13) exist, but he analyzes them as “reason” applicatives, which he assumes have a distinct syntax from beneficiaries. Alsina & Mchombo (1990) provide evidence that these data are in fact cases of a benefactive applicative.

The data in (15) show that the instrumental applied object can be the subject of a passive as well as object-marked on the verb, which is incorrectly ruled out on Baker’s analysis.

Finally, Baker assumes on conceptual grounds that locatives will pattern like benefactives, and, thus, it is expected that his account would predict that syntactically locative and benefactive applicatives should pattern alike. Alsina & Mchombo (1990) show that locatives in fact pattern mostly with instrumental applicatives, in that there is flexible word order (16).

- (16) a. *A-lēnje a-ku-lúk-ír-a pa-m-chēnga mi-kêka.*
 2-hunters 2S-PRES-weave-APPL-FV 16-3-sand 4-mats
 ‘The hunters are weaving mats on the beach.’
- b. *A-lēnje a-ku-lúk-ír-a mi-kêka pa-m-chēnga.*
 2-hunters 2S-PRES-weave-APPL-FV 4-mats 16-3-sand
 ‘The hunters are weaving mats on the beach.’

(Chicheŵa; Alsina & Mchombo 1990:504,(19))

However, it is not the case that locative applicatives always pattern like instruments; in passivization, locative applicatives are unlike benefactive and instrumental applicatives in that both objects can be the subject of a passive.

- (17) a. *Pa-m-chēnga pa-ku-lúk-ír-idw-á mí-kêka.*
 16-3-sand 16S-PRES-weave-APPL-PASS-FV 4-mats
 ‘The beach is being woven mats on.’
- b. *Mi-kêka i-ku-lúk-ír-idw-á pá-mchēnga.*
 4-mats 4S-PRES-weave-APPL-PASS-FV 16-3-sand
 ‘The mats are being woven on the beach.’

(Chicheŵa; Alsina & Mchombo 1990:504,(21))

These data shown that locatives do not pattern like instrumental or benefactive applicatives in object properties. The issue is that he assumes that because of a putative parallel semantics with benefactives and locatives that the two should share syntactic structure, though

this is clearly not an appropriate assumption given the radically distinct behavior of the two applicatives. This assumption, however, has persisted through to recent work, which I discuss in the next subsection.

In a later paper, Alsina & Mchombo (1993) argue instead that the distinction arises from the position of an applied object on the thematic role hierarchy in (18), adopted from Bresnan & Kanerva (1989), though their analysis suffers from many of the same assumptions that ultimately problematize Baker's approach, despite the significant difference in theoretical perspective. Their analysis is that any internal role hierarchically lower than goal/experiencer are able to have the intrinsic classification of [+o] (for objective); any internal argument can receive the [-r] feature which means they are unrestricted (i.e. the thematic role is not restricted to a specific grammatical function). Furthermore, there is a default that requires the theme to be assigned [+o] when there is another object argument with a higher role in the hierarchy.¹⁰

(18) ag > ben > go/exp > ins > pt/th > loc (Alsina & Mchombo 1993:24,(9))

The applied beneficiary role can only have the intrinsic classification of [-r], while the instrumental object can be assigned [-r] or [+o]. In an applied predicate, the beneficiary is unrestricted (namely, it is the "core" object) while the theme is the restricted object, meaning the beneficiary must precede the thematic object, and the beneficiary may be object marked. With instrumental applicatives, on the other hand, either the instrumental object or the thematic object can receive either classification, meaning that word order is free and both can be object-marked on the verb. It is never clearly stated why being the unrestricted object should necessarily correlate with these grammatical facts, leaving it unclear what predictions actually follow from the analysis. Furthermore, it is unintuitive to me that the theme is the restricted object in benefactive sentences, since being a restricted object in the theory is supposed to be reserved for thematically restricted objects.

¹⁰See Levin & Rappaport Hovav (2005:154-183) for a critical discussion of the use of thematic role hierarchies in making grammatical generalizations.

Granting these unexplained points in the theory, the theory still crucially relies on the notion that the thematic role of the applicative will correlate with the syntactic behavior of object symmetry. As I show in §3, the generalizations they propose for Chicheŵa cannot be extended to either Kinyarwanda or Lubukusu, in the same ways that Baker’s analysis will also fail to extend since both of these analyses have made the thematic role the cornerstone of the analysis. Cross-linguistic data simply does not support a universal link between thematic role and syntax.

2.3 Minimalist Approaches to Symmetry

The key assumption that thematic role universally correlates with a specific syntax which in turn derives object symmetry persists through most recent work on object symmetry from a Minimalist perspective, which has tied thematic role to where the applicative head is merged into the syntax, often by use of the typology of high/low applicatives discussed in §3 of Chapter 4. One approach to object symmetry ties symmetry to phases, a notion first proposed by Chomsky (2000, 2001). Phases are syntactic domains that are arguably chunks of syntax “sent off” to given phonetic form and to be interpreted in the semantics. Phases are generally assumed to be impenetrable to movement (except for a constituent at the edge of the phase), with the idea being that they are already chunked as complete syntactic units. McGinnis (2001) ties phases to applicatives, arguing that the sister of VP heads a phase if it assigns a theta-role to a syntactic argument.¹¹ Given the difference in syntactic structure of high and low applicatives (first introduced in Chapter 4, §3.1.2 and repeated in (19)), this makes specific predictions about how the two applicative types are chunked into phases. With the high applicative, the applied and direct objects are in separate phases, while with the low applicative, both objects are in the same phase. Given that A-movement respects locality, a lower argument can raise to the subject position with the high applicative because

¹¹Related — though formally distinct — proposals appear in McGinnis (2004), McGinnis & Gerds (2003), and McGinnis (2008), but the core intuition that phases drive object asymmetries is the same across all of these.

a phase-EPP feature can be added to the High Applicative in the passive, allowing the lower argument to leapfrog over the higher one. Once the DO occupies a higher specifier of High Appl head, it is the closest DP to T, and it can move to spec-T. With the low applicative, on the other hand, the ApplP is not a phase, and no phase-EPP feature can be added. Hence, the lower object cannot raise higher than the applied object.

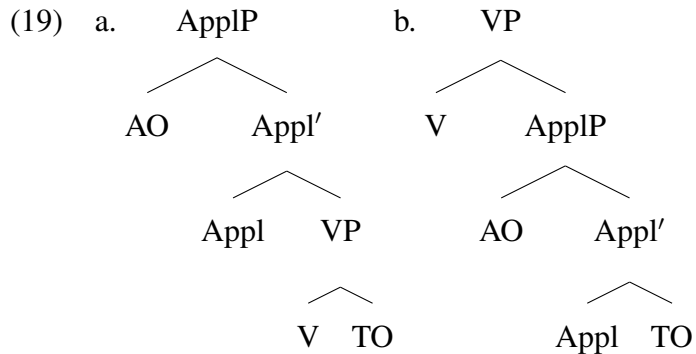

In sum, due to the configurational structure of the two different applicative phrases, the phase boundaries differ, which makes different predictions about the symmetry properties of high and low applicative types.¹² In short, when the two are in separate phases, there is symmetry, but when they are in the same phase, there is asymmetry.

Jeong (2007) argues against the phase-based analysis of McGinnis (2001), noting that there are languages with asymmetric high applicatives and symmetric low applicatives (see the following section for considerable elaboration on this point), which are unexpected in McGinnis's system. However, Jeong retains the distinction between high and low applicatives from Pylkkänen (2008), but argues that whether two objects are symmetrical derives instead from an anti-locality constraint which states that when two similar elements are in same type of projection, the lower element cannot move across the higher one. The result is similar to McGinnis's phase-based approach in that High applicatives are predicted to be symmetrical while low applicatives are predicted to be asymmetrical. Jeong's system differs from McGinnis's in that other factors, such as how inherent Case assignment and

¹²Baker et al. (2012) also use phase theory to distinguish the symmetry properties of applicatives and morphological causatives in Lubukusu, arguing that the latter contains an extra phase boundary. The focus of their paper is on the asymmetries that arise when different personal pronouns are used as objects. I do not engage with this set of empirical facts here.

“scrambling” can modify the default symmetry properties of the high or low applicative. However, Jeong does not actually concern herself directly with showing how her analysis captures the range of facts found in actual (morphological) applicatives in Bantu languages; instead, the rest of her book addresses high and low applicatives in other language families, eschewing the original question of symmetry. While the details are not made clear for Bantu, the general system seems to be that there is a default that high applicatives are symmetrical and low applicatives are asymmetrical (due to the locality condition), unless other factors intervene. But while this framework could in principle capture variation in symmetry, there is no empirical reason presented for associating symmetry with either a high or low structure even by default, making it difficult to see the explanatory value in such a system. A further issue is that Bantu languages (or at least Eastern African Bantu languages) have been claimed to not have Case (Diercks 2012), which means that any Case-based explanations need considerable language-internal motivation for the presence of structural Case.

Zeller (2006) and Zeller & Ngoboka (2006) also argue that locality is the crucial component to capturing symmetry. They argue that with locative applicatives in Kinyarwanda, the locative object is higher than the theme. Per the Minimal Link Condition (cf. Chomsky 1995, 2001, 2000), it is predicted that the only argument accessible to raise to the subject of a passive as well as be object-marked (or incorporated, in their theory) is the applied object. Note, however, that the paper only discusses the *-ho* applicative, which, as they show, is asymmetrical with respect to passive, object marking, and word order diagnostics.¹³

However, in a different dialect of Kinyarwanda (i.e. the dialect of the speakers who contributed the data at the center of the discussion in Chapter 3) where the applicative *-ir* marks locative applicatives, both the applied and thematic objects can be subjects of a passive and be object-marked with the locative applicative. Examples (21a-b) show that both can be the subject of a passive, while (22a-b) shows that both can be object-marked

¹³See also Kimenyi (1980).

on the verb.

- (20) *Umu-higi y-a-tem-ey-e igi-ti mw' i-shyamba.*
1-hunter 1S-PST-cut-APPL-PERF 7-tree 16.LOC 5-forest
'The hunter cut the tree in the forest.'
- (21) a. *Mw' i-shyamba h-a-tem-e-w-e igi-ti n' umu-higi.*
16.LOC 5-forest 16S-PST-cut-APPL-PASS-PERF 7-tree by 1-hunter
'In the forest was cut the tree by the hunter.'
- b. *Igi-ti cy-a-tem-e-w-e mw' i-shyamba n' umu-higi.*
7-tree 7S-PST-cut-APPL-PASS-PERF 16.LOC 5-forest by 1-hunter
'The tree was cut in the forest by the hunter.'
- (22) a. *Umu-higi y-a-ha-tem-ey-e igi-ti.*
1-hunter 1S-PST-16O-cut-APPL-PERF 7-tree
'The hunter cut the tree there.'
- b. *Umu-higi y-a-gi-tem-ey-e mw' i-shyamba.*
1-hunter 1S-PST-7O-cut-APPL-PERF in 5-forest
'The hunter cut it in the forest.'

The data in (21) and (22) show that both locative and thematic objects can be subjects of a passive and object-marked with the *-ir* locative applicative in Kinyarwanda, which indicates that this locative applicative is symmetrical. While these data do not negate the analysis of Zeller (2006) and Zeller & Ngoboka (2006), the fact that a single thematic role within a single language should pattern differently with respect to symmetry diagnostics strongly casts doubt on the assumption in the literature that a given thematic role is correlated to specific syntactic structures even in one language.

A broader issue for any analysis that relies on high and low applicative structures, however, is that there exist certain cases in which it is not even clear whether the applicative is high or low (cf. the related discussion in Chapter 4, Section 3). In Kinyarwanda, for example, the benefactive applicative has properties that are attributed to both high and low applicative structure. First, the ability of the benefactive to appear with unergatives and statives, as in (23) and (24), suggests the applicative is high.

(23) *N-d-iruk-ir-a* *Karemera.*
 1SGS-PRES-run-BEN-IMP Karemera
 ‘I am running for Karemera.’

(24) *M-fat-iy-e* *umu-fuka Karemera.*
 1SGS-hold-BEN-IMP 3-bag Karemera
 ‘I am holding the bag for Karemera.’

On the other hand, the benefactive morpheme may also encode change-of-possession, suggesting that the Appl head is low (on the prevailing assumption in the literature that semantics must correlate with syntactic structure). In (25), the subject is sending money to his or her parents, who are benefitting from the prospective receiving of the money and also (crucially) receiving the money.

(25) *A-z-oher-er-eza* *ama-faranga aba-byeyi ba-njye.*
 1S-FUT-send-BEN-IMP 6-money 2-parent 2-my
 ‘S/he will send my parents money.’

Appearing with intransitives in (23) and (24) suggests that the Appl head is high in Kinyarwanda benefactives, while the change-of-possession reading in (25) is a classic property of low applicatives. Not only do the different properties suggest different heights of the applicative, the fact that some verbs may allow a transfer-of-possession reading and others do not parallels the critique posed in Chapter 4, which pointed out based on English data that the possibility of having a benefactive direct object is contingent upon verb meaning. With the case in (25), this extends to high applicatives with certain verbs which require change-of-possession.

Returning to the question of symmetry, these data in fact derive contradictory predictions about what the symmetry properties of applicatives are. From the intransitive data in (23) and (24), the applicative should be high, and therefore, symmetrical; however, due to the transfer-of-possession reading in (25), the applicative should be low, predicting asymmetry. The benefactive applicative is almost always symmetrical in Kinyarwanda

with nearly any diagnostic (see §3), which is unexpected if the sentence in (25) is semantically low. This issue is not limited to the empirical variation of the benefactive applicative in Kinyarwanda; as I show in the next subsection, the use of high and low applicatives is also problematic on theoretical grounds.

2.4 The Semantics of High and Low Applicatives

My fundamental claim is that there is no reason to assume a tight correlation between semantics and syntactic structure, yet most previous work assumes exactly this. This assumption is perhaps clearest in the high-low applicative typology, where the semantics of transfer of possession is a core property of the low applicative head. The denotation that Pylkkänen provides for a high applicative is given in (26a) and the denotation for a low applicative in (26b), cf. Pylkkänen (2008:16-19,26-27). The corresponding syntactic structures are repeated in (27a-b) for clarity.

- (26) a. $\llbracket \text{ApplH} \rrbracket := \lambda x \lambda e [benefactive(e, x)]$
 b. $\llbracket \text{ApplL} \rrbracket := \lambda x \lambda y \lambda f_{\langle e, \langle s, t \rangle \rangle} \lambda e [f(e, x) \wedge theme(e, x) \wedge to.the.possession(x, y)]$

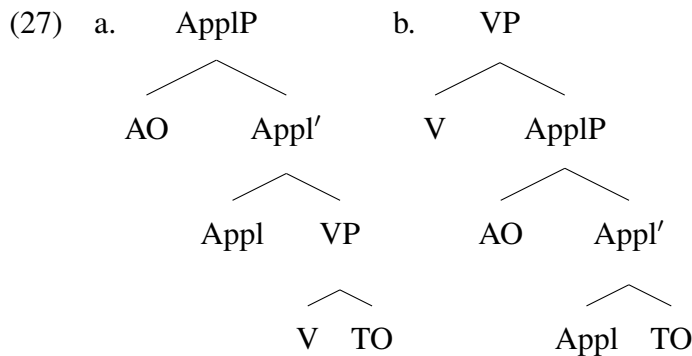

The high applicative head straightforwardly takes a beneficiary argument and event variable, and corresponds to the structure in (27a). The low applicative corresponds to the structure in (27b), with the semantics in (26b), which — unlike the high applicative — has two semantic participants in addition to an event variable. With high applicatives, the

applicative head is treated as a functional head introducing an argument that is external to the verb, paralleling Kratzer's (1996) treatment of external arguments.

In order to tease apart the assumptions of the applicative analysis, it is fruitful to first consider the details of the analysis outlined by Kratzer (1996). She argues that external arguments are licensed by a separate head from the main verb (now often referred to as the "little-*v* hypothesis," though she originally called the head "Voice"). One of the main arguments for the little-*v* hypothesis, building on Marantz (1984), is that external arguments are not true arguments of the verb, with the main piece of evidence being that internal arguments are more likely to form idioms with verb than external arguments (cf. Kratzer 2006:114, Marantz:1984).¹⁴ Kratzer argues that if the external argument is specified in the meaning of the verb, then there is no technical obstacle to having a verb meaning which specifies information about the external argument, which is undesired given the putative restriction that external arguments are not chunked as parts of idioms.¹⁵ The claim goes that if external arguments are arguments of the verb, there is nothing preventing conditions such as those in (28) on external arguments, where f is a function which yields an output for the individuals b (the referent of the subject) and a (the referent of the object).

- (28) a. If b is a time interval, then $f(a, b) = \text{truth}$ iff a exists during b
b. If b is a place, then $f(a, b) = \text{truth}$ iff a is located at b
c. if b is a person, then $f(a, b) = \text{truth}$ iff b is the legal owner of a

(Kratzer 1996:114,(10))

For Kratzer, these kinds of conditions are not desired if Marantz's generalization is to be maintained; if the external argument is an argument of the verb, there is nothing preventing the verb from specifying narrow restrictions on the external object. However, she claims

¹⁴There has also been work showing that Marantz's original generalization about external objects is in fact touching on a separate tendency for *animate* arguments to occupy open positions of idioms as opposed to being incorporated as idiom chunks, not necessarily that subjects *per se* are less likely to be part of idioms (Nunberg et al. 1994).

¹⁵Because Pyllkänen's analysis of high applicatives treats them as external arguments, it is predicted that — to the degree to which Marantz's (1984) claim is valid — high applicatives cannot form idioms with the verb, while low applicatives (which are within the VP) can in principle form idioms with the verb. I am not aware of any work that fleshes out this prediction.

that if the external argument is not an argument of the verb, then no such conditions constraining verb meaning by the subject are possible.

Wechsler (2005), however, shows convincingly that there is in fact no technical obstacle to reformulating the conditions in (28) in terms of the external argument Kratzer proposes. He gives the revised conditions in (29), which specify the Agent of e , which refers to the external argument that — on Kratzer’s approach — is licensed externally to the verb. Crucially, the conditions in (29) can be stated at the level of “big V;” i.e. before little- v is merged and picks up the agent.

- (29) a. If the Agent of e is a time interval, then $f(a, e) = \text{truth}$ iff a exists during the Agent of e
- b. If the Agent of e is a place, then $f(a, e) = \text{truth}$ iff a is located at the Agent of e
- c. If the Agent of e is a person, the $f(a, e) = \text{truth}$ iff the Agent of e is the legal owner of a (Wechsler 2005:183,(8))

In (29), the conditions on the external argument are revised to restrict the Agent of e , which would — on Kratzer’s little- v proposal — be able to specify conditions on the external argument. Having the selectional restriction mediated through the event argument has the same effect in (29) as Kratzer’s undesired restrictions in (28), in effect showing that Kratzer’s little- v hypothesis does not solve the problem it sets out to solve. More broadly, it shows that semantic stipulations can be made about arguments that have not yet combined with the predicate.

Returning to Pylkkänen’s high-low typology, the semantics she proposes in (26a) relies on the same assumption as Kratzer’s analysis; namely, that by virtue of the syntactic position of a functional head, it is not possible to specify semantic information regarding particular arguments. However, there is again no technical reason that the transfer reading cannot be indicated on the high applicative, despite the widespread assumption that this is the case. Following Wechsler (2005), one could propose the condition in (30) on the mean-

ing of a high applicative, where a is the argument licensed by the applicative and f is a relation contributed by the applicative.

(30) If the Theme of e is an individual, then $f(a, e) = \text{truth}$ iff a receives the Theme

Here, the interpretation of the beneficiary role of high applicative is contingent upon the a receiving the theme of the verb with which applicative head attaches; in other words, there is no technical obstacle to specifying a transfer of possession reading on a high applicative. Formally, the correct way to capture this generalization might be to define a *recipient* role that must receive some entity. While it would not be explicit which entity is transferred in possession, a constraint could specify that any item received is the theme of the verb. On this analysis, the denotation of a high applicative with a transfer-of-possession reading would be the following:

(31) $\llbracket \text{ApplH} \rrbracket := \lambda x \lambda e [recipient'(e, x) \wedge \forall y [th'(e, y) \rightarrow receive(e, x, y)]]$

The composition of the head in (31) would proceed exactly as the high applicative in Pylkkänen's model, but with the crucial difference that this high applicative specifies transfer of possession.

Similarly, there is nothing which prevents the low applicative from having a general beneficiary reading, as in the denotation in (32) for a low applicative head with a general beneficiary.

(32) $\lambda x \lambda y \lambda f_{\langle e, \langle s, t \rangle \rangle} \lambda e [f(e, x) \wedge theme(e, x) \wedge beneficiary(e, y)]$

The formula in (32) provides the denotation of a low applicative with a general beneficiary reading which can be combined in a low applicative structure in (27b) just like the denotation Pylkkänen gives in (26b).¹⁶ In short, the problem with the high/low applicative analysis is that there is no obvious reason to connect syntactic structure with semantics.¹⁷

¹⁶It seems highly improbable to me that the low applicative in any case should be licensing the theme object, which intuitively is more naturally a participant of the verb. However, for sake of argument, I include it in (32) for parallelism with Pylkkänen's analysis of low applicatives.

¹⁷Moreover, as mentioned in Chapter 1, there are several kinds of related benefactive meanings across languages which are not captured by the binary opposition between whether a direct object codes transfer of possession (Kitilä 2005, Kitilä & Zúñiga 2010).

Given that any syntactic structure could in principle be associated with any semantics, the null hypothesis is that there should *not* be a correlation between symmetry and thematic role, thus the mismatch between syntax and semantics is expected from the null hypothesis. In the next section, I offer a more thorough argument that it is empirically inaccurate to rely on a tight correlation between syntax and semantics, as no analysis that links semantic role to syntactic structure can accurately capture the diversity of symmetry facts in Bantu languages.

3 Variation Across Languages and Diagnostics

In the previous section I gave a critical summary of work on object symmetry to date. While there have been several proposals made since object symmetry in applicatives was first discussed in the 1970's, most previous analyses rely (implicitly or explicitly) on two broad assumptions: (i) thematic role correlates with a particular pattern of symmetry, and (ii) all objecthood diagnostics hinge on a single parameter of variation. Just from cited data in the previous section it is clear that these assumptions are problematic on theoretical and empirical grounds. However, prior works are also often non-comparable as they do not always hold complicating factors constant. In this section, I push the point further, providing cognate data from three languages that exemplify the extent of the variation found in symmetry diagnostics for different thematic role types across languages as well as the variation in the behavior of diagnostics within even a single language.

In particular, previous analyses did not intentionally hold verb, thematic role, diagnostic, and noun cast constant in comparing applicative types across languages. The data collected for this section were collected in order to do exactly that: compare cognate sentences across three languages in order to tease apart the degree to which particular symmetry properties are universal. Given the fact that these languages vary in the known symmetry properties of different applicatives provides strong evidence against any universality. The data come

from Kinyarwanda, Chicheŵa, and Lubukusu for three thematic role types of applicatives (benefactive, instrumental, and locative) as well as for morphological causatives. Four objecthood tests — word order, pronominalization, promotion to subject in passivization, and relativization — were chosen for being the most common used in prior literature.

Furthermore, animacy of the applied and thematic object is known to have an effect on symmetry (Morolong & Hyman 1972, Hyman & Duranti 1982, Aranovich 2009). While I did not contrast animate and inanimate applied and thematic objects in each language, I ensured that the animacy of the nouns were held constant in the cognate sentences in each of the languages. An immediate next step for future research is to compare varying animate/inanimate objects with each applicative type in each of the languages. Person is also known to be relevant, where the presence of first- and second-person pronouns in object position result in preference for the applied object/causee to be treated as the core object (Baker et al. 2012), though I did not pursue the full range of this in the present study. In order to maintain consistency, however, all object DPs here are third person, minimally keeping the noun cast the same across the three languages.

Finally, the previous two chapters show that verb class is important in the argument realization of applied objects, and from this it is natural to assume that verb class may also figure into the syntax of argument structure. In order to test this, seven verbs from six (di)transitive verb classes were chosen representing major types independently known to have distinct argument realization properties across languages: ditransitive verbs ('send'; Rappaport Hovav & Levin 2008, Beavers 2011a), transitive manner/surface contact verbs ('hit'; Rappaport Hovav & Levin 2010), cutting and slicing verbs ('cut'; Koenig et al. 2008, Beavers 2010), externally caused change-of-state verbs ('break'; Levin & Rappaport Hovav 1995), creation verbs ('build'; Hopper 1985), and consumption verbs ('drink' and 'eat'; Amberber 2002) (see also Levin 1993 more broadly).

In each of the following subsections I outline the symmetry facts for benefactive, loca-

tive, and instrumental applicatives, followed by morphological causatives, respectively. After summarizing the attested variation across the different types of applicative, I discuss the use of resumptive pronouns and oblique marking with certain diagnostics, tentatively proposing that these serve as a strategy for disambiguating arguments in particular cases in each of the languages. Finally, I turn to a brief discussion of other kinds of asymmetries that have been discussed with respect to applied objects, arguing that the results of these diagnostics provide further evidence for disassociating semantic role from syntactic structure. However, verb class had less of an effect than hypothesized, except for the case of caused ingestive verbs in Lubukusu — see §4 of this chapter. For this reason, I do not present the data from each verb from the study since the data are parallel across the different verbs.

3.1 Benefactive Applicatives

Let us first consider three cognate sentences in Chicheŵa, Kinyarwanda, and Lubukusu, which use a benefactive applicative on the equivalent of the verb *to build*:¹⁸

- (33) *A-mfumu a-na-mang-ir-a mw-ana nyumba.*
 2-chief 2S-PST-build-APPL-IMP 1-child 9.house
 ‘The chief built the house for the child.’ CHW
- (34) *Umu-yobozi y-∅-ubak-iy-e umw-ana in-zu.*
 1-chief 1S-PST-build-APPL-IMP 1-child 9-house
 ‘The chief built the house for the child.’ KR
- (35) *Omw-ami ku-∅-mbakh-il-a omw-ana en-ju.*
 1-chief 1S-PST-build-APPL-FV 1-child 9-house
 ‘The chief built the house for the child.’ LBK

Crucially, the animacy of the nouns was kept constant in the comparison across the three languages (i.e. animate applied object and inanimate thematic object). By keeping the animacy of the two nouns consistent in the cognate sentences, it is possible to compare the

¹⁸On the right margin of all the data are given an abbreviation for each of the languages: CHW for Chicheŵa, KR for Kinyarwanda, and LBK for Lubukusu. I chose not to use their ISO codes (NYA, KIN, and BXK, respectively) because they were not as iconic.

other grammatical factors of objecthood for the objects in each of the languages.

One difference is that Kinyarwanda and Lubukusu are flexible with the order of the two objects, while Chicheŵa is restricted; speakers prefer that the beneficiary precede the theme. Crucially here, for speakers in Chicheŵa who allow the order in (36), it does not mean the same thing as (33).

(36) *A-mfumu a-na-mang-ir-a nyumba mw-ana .*
 2-chief 2S-PST-build-APPL-IMP 9.house 1-child
 ‘The chief built the child the house.’ CHW

(37) *Umu-yobozi y-∅-ubak-iy-e in-zu umw-ana.*
 1-chief 1S-PST-build-APPL-IMP 1-child 9-house
 ‘The chief built the child the house.’ KR

(38) *Omwa-ami ku-∅-mbakh-il-a en-ju omwa-ana*
 1-chief 1S-PST-build-APPL-FV 9-house 1-child
 ‘The chief built the house for the child.’ LBK

A further difference among the languages is whether the thematic object can appear as an object marker on the verb. In Chicheŵa, the theme cannot be an object marker on the verb, as shown in (39), while in Kinyarwanda and Lubukusu, both objects can appear as object markers, as in (40) and (41), respectively.

(39) a. *A-mfumu a-na-mu-mang-ir-a nyumba.*
 2-chief 2S-PST-1O-build-APPL-IMP 9.house
 ‘The chief built the house for him/her.’

b. **A-mfumu a-na-i-mang-ir-a mw-ana.*
 2-chief 2S-PST-9O-build-APPL-IMP 1-child
 ‘The chief built it for the child.’ CHW

(40) a. *Umu-yobozi y-a-mw-ubak-iy-e in-zu.*
 1-chief 1S-PST-1O-build-APPL-PERF 9-house
 ‘The chief built the house for him/her.’

b. *Umu-yobozi y-a-y-ubak-iy-e umw-ana.*
 1-chief 1S-PST-9O-build-APPL-PERF 1-child
 ‘The chief built it for the child.’ KR

- (41) a. *Omw-ami k-a-mw-ombakh-il-a en-ju.*
 1-chief 1S-PST-1O-build-APPL-FV 9-house
 ‘The chief built the house for him/her.’
- b. *Omw-ami k-a-ki-ombakh-il-a omw-ana*
 1-chief 1S-PST-7O-build-APPL-FV 1-child
 ‘The chief built it for the child.’ LBK

Another difference is whether the theme can be the subject of a passive. In (42b), the theme is ungrammatical as the subject of a passive in Chicheŵa, while in (42a) the beneficiary is grammatical as the subject of a passive. In the Kinyarwanda and Lubukusu examples in (43) and (44), both the theme and the beneficiary can be subjects of the passive.

- (42) a. *Mw-ana a-na-mang-ir-idw-a nyumba ndi a-mfumu.*
 1-child 1S-PST-build-APPL-PASS-IMP 9.house by 2-chief
 ‘The child was built the house by the chief.’
- b. **Nyumba i-na-mang-ir-idw-a mw-ana ndi a-mfumu.*
 9.house 9S-PST-build-APPL-PASS-IMP 1-child by 2-chief
 ‘The house was built for the child by the chief.’ CHW
- (43) a. *Umw-ana y-∅-ubak-i-w-e in-zu n’ umu-yobozi.*
 1-child 1S-PST-build-APPL-PASS-PERF 9-house by 1-chief
 ‘The child was built the house by the chief.’
- b. *In-zu y-∅-ubak-i-w-e umw-ana n’ umu-yobozi.*
 9-house 9S-PST-build-APPL-PASS-PERF 1-child by 1-chief
 ‘The house was built for the child by the chief.’ KR
- (44) a. *Omw-ana k-∅-ombakh-il-w-a en-ju ne omw-ami.*
 1-child 1S-PST-built-APPL-PASS-FV 9-house by 1-chief
 ‘The child was built the house by the chief.’
- b. *En-ju y-∅-ombakh-il-w-a omw-ana ne omw-ami.*
 9-house 1S-PST-build-APPL-PASS-FV 1-child by 1-chief
 ‘The house was built for the child by the chief.’ LBK

The final diagnostic is whether an object can be extracted in a relative clause. For Chicheŵa, the theme can be extracted without issue; the beneficiary, however, can be ex-

tracted, but only if the embedded verb has a resumptive object marker for the extracted beneficiary, shown in (45). Without this resumptive pronoun, the sentence is interpreted as if the child is used as a material in order to build the house, i.e. the interpretation is that of an instrumental applicative. For now, I take this to mean that extraction of beneficiaries is thus ungrammatical, but I resume the discussion of resumptive pronouns below in §3.6.

- (45) a. *Iyi ndi nyumba i-mene a-mfumu a-na-mang-ir-a mw-ana.*
 3.this is 3.house 3S-that 2-chief 2S-PST-build-APPL-FV 1-child
 ‘This is the house that the chief built for the child.’
- b. *Uyu ndi mw-ana a-mene a-mfumu a-na-*(m’)-mang-ir-a nyumba.*
 1.this is 1-child 1S-THAT 2-chief 2S-PST-1O-APPL-FV 3.house
 ‘This is the child that the chief built the house for.’ CHW
- (46) a. *Iyi ni-yo n-zu umu-yobozi y-∅-ubak-iy-e umw-ana.*
 9.this COP-9 9-house 1-chief 1S-PST-build-APPL-PERF 1-child
 ‘This is the house that the chief built for the child.’
- b. *Uyu ni-we mw-ana umu-yobozi y-∅-ubak-iy-e in-zu.*
 1-this COP-1 1-child 1-chief 1S-PST-build-APPL-PERF 9-house
 ‘This is the child for whom the chief built the house.’ KR
- (47) a. *Eyino (e-li) en-ju niyo omw-ami (k-)∅-ombakh-il-a omw-ana.*
 9.this 9-COP 9-house that 1-chief 1S-PST-build-APPL-FV 1-child
 ‘This is the house that the chief built for the child.’
- b. *Oyuno (a-li) omw-ana niye omw-ami ∅-∅-ombakh-il-a en-ju.*
 1.this (1.-COP) 1-child that 1-chief 1S-PST-build-APPL-FV 9-house
 ‘This is the house that the chief built for the child.’ LBK

Table 9 summarizes the symmetry patterns for the cognate sentences in the three sample languages. The four diagnostics, moving left-to-right, are word order, object-marking, ability to be the subject of a passive, and relative clause formation. The check (✓) indicates that the object under discussion permits a specific pattern, while the star (*) indicates that the object is ungrammatical in the specific diagnostic. Question marks (??) indicate that there is speaker variation in the judgment. Finally, the tilde (~) indicates that the form is

ungrammatical in the absence of some other grammatical marker (such as the resumptive pronoun in (45b), which is obligatory to have a felicitous reading of the sentence).

<i>Language</i>	<i>Obj</i>	<i>WO</i>	<i>OM</i>	<i>Pass</i>	<i>Rel</i>
Chicheŵa	Ben	✓	✓	✓	~
	Th	??	*	*	✓
Kinyarwanda	Ben	✓	✓	✓	✓
	Th	✓	✓	✓	✓
Lubukusu	Ben	✓	✓	✓	✓
	Th	✓	✓	✓	✓

Table 9: Objecthood diagnostics for the benefactive applicative

The table in 9 shows that the benefactive is symmetrical with all diagnostics in Kinyarwanda and Lubukusu. In Chicheŵa, however, the benefactive is asymmetrical, with the beneficiary object obligatorily preceding the theme and the only object that can be an object marker on the verb or the subject of a passive. Unlike the other diagnostics in the language, the beneficiary object cannot be extracted in a relative clause (without additional grammatical structures). The theme is restricted in Chicheŵa across all diagnostics except for relativization, where it can be extracted.

3.2 Locative Applicatives

In this section, I turn to the locative applicative. I use an inanimate theme and a pragmatically appropriate location for that theme to be located. The first diagnostic is word order, which is fixed for Chicheŵa, but flexible for the other two languages. Note that the restriction is different from the assumption of word order restrictions in previous literature; in general, if there is an asymmetry, previous work has assumed that the applied object will precede the thematic object. In the case of word order with locative applicatives in Chicheŵa, the locative applied object must follow the theme, as shown in (48). In both Kinyarwanda and Lubukusu the word order is symmetrical, as shown in (49) and (50).

- (48) a. *M-lenji a-na-dul-ir-a m-kate m-nyumba.*
 1-hunter 1S-PST-cut-APPL-FV 3-bread 18-3.house
 ‘The hunter cut the bread in the house.’
- b. **M-lenji a-na-dul-ir-a m-nyumba m-kate*
 1-hunter 1S-PST-cut-APPL-FV 19-3.house 3-bread
 ‘The hunter cut the bread in the house. CHW
- (49) a. *Umu-higi y-a-tem-ey-e igi-ti mw’ i-shyamba.*
 1-hunter 1S-PST-cut-APPL-PERF 7-tree LOC 5-forest
 ‘The hunter cut the tree in the forest.’
- b. *Umu-higi y-a-tem-ey-e mw’ i-shyamba igi-ti.*
 1-hunter 1S-PST-cut-APPL-PERF in 5-forest 7-tree
 ‘The hunter cut the tree in the forest.’ KR
- (50) a. *Omu-hayi a-∅-khal-il-a ku-mu-kati mu-n-ju.*
 1-hunter 1S-PST-cut-APPL-FV 3-3-bread 18-9-house
 ‘The hunter cut the bread in the house.’
- b. *Omu-hayi a-∅-khal-il-a mu-n-ju ku-mu-kati.*
 1-hunter 1S-PST-cut-APPL-FV 18-9-house 3-3-bread
 ‘The hunter cut the bread in the house.’ LBK

Turning to object marking, for the speakers consulted regarding the Chicheŵa data, the locative object marker is not acceptable, as shown in (51b-c).¹⁹ The theme, on the other hand, was acceptable as an object marker, as shown in (51a). Note that object markers both for the locative class and the class of the noun itself were used (shown in (51b-c)), but neither was judged grammatical. In Kinyarwanda, both objects can be marked on the verb in (52), while Lubukusu does not allow the locative to be marked on the verb in (53).

¹⁹Though see Alsina & Mchombo (1993), who do cite a locative object marker in the dialect of Sam Mchombo.

- (51) a. *M-lenji a-na-u-dul-ir-a m-nyumba.*
 1-hunter 1S-PST-3O-cut-APPL-FV 18-9.house
 ‘The hunter cut it in the house.’
- b. **M-lenji a-na-mu-dul-ir-a m-kate.*
 1-hunter 1S-PST-18O-cut-APPL-FV 3-bread
 Intended: ‘The hunter cut the bread there.’
- c. **M-lenji a-na-i-dul-ir-a m-kate.*
 1-hunter 1S-PST-9O-APPL-FV 3-bread
 Intended: ‘The hunter cut the bread there.’ CHW
- (52) a. *Umu-higi y-a-ha-tem-ey-e igi-ti.*
 1-hunter 1S-PST-16O-cut-APPL-PERF 7-tree
 ‘The hunter cut the tree there.’
- b. *Umu-higi y-a-gi-tem-ey-e mw’ i-shyamba.*
 1-hunter 1S-PST-7O-cut-APPL-PERF in 5-forest
 ‘The hunter cut it in the forest.’ KR
- (53) a. *Omu-hayi a-∅-ku-khal-il-a mu-n-ju.*
 1-hunter 1S-PST-3O-cut-APPL-FV 18-9-house
 ‘The hunter cut it in the house.’
- b. **O-mu-hayi a-∅-mu-khal-il-a ku-mu-kati.*
 1-1-hunter 1S-PST-18O-cut-APPL-FV 3-3-bread
 ‘The hunter cut the bread there.’ LBK

The passive diagnostic is symmetrical for all three languages. Note however that the locative clitic is obligatory with the Lubukusu passive. I return to this in §3.6.

- (54) a. *M-nyumba mu-na-dul-ir-idw-a m-kate.*
 18-9.house 18-PST-cut-APPL-PASS-FV 3-bread
 ‘In the house was cut the bread.’
- b. *M-kate u-na-dul-ir-idw-a m-nyumba.*
 3-bread 3S-PST-cut-APPL-PASS-FV 18-9.house
 ‘The bread was cut in the house.’ CHW

- (55) a. *Igi-ti cy-a-tem-e-w-e mw' i'shyamba na umu-higi.*
 7-tree 7S-PST-cut-APPL-PASS-PERF LOC 5-forest by 1-hunter
 'The tree was cut in the forest by the hunter.'
- b. *Mw' i-shyamba h-a-tem-e-w-e igi-ti na umu-higi.*
 18 5-forest 16-PST-cut-APPL-PASS-FV 7-tree by 1-hunter
 'In the forest was cut a tree by the hunter.' KR
- (56) a. *Ku-mu-kati kw-a-khal-il-w-a-*(mo) mu-n-ju ne omu-hayi.*
 3-3-bread 3S-PST-cut-APPL-PASS-FV 18-9-house by 1-hunter
 'The bread was cut in the house by the hunter.'
- b. *Mu-n-ju mw-a-khal-il-w-a-*(mo) ku-mu-kati ne omu-hayi.*
 18-9-house 18-PST-cut-APPL-PASS-FV-18O 3-3-bread by 1-hunter
 'In the house was cut the bread by the hunter.' LBK

The relative clause in all three languages is also symmetrical, though note that in Kinyarwanda the locative clitic is obligatory when the locative phrase is extracted. I return to this below in §3.6.

- (57) a. *Uwu ndi m-kate u-mene m-lenji a-na-dul-ir-a m-nyumba.*
 3.this COP 3-bread 3-that 1-hunter 1S-PST-cut-APPL-FV 18-9.house
 'This is the bread that the hunter cut in the house.'
- b. *Iyi ndi nyumba i-mene m-lenji a-na-dul-ir-a m-kate.*
 9.this COP 9.house 9-that 1-hunter 1S-PST-cut-APPL-FV 3-bread
 'This is the house in which the hunter cut the bread.' CHW
- (58) a. *Iri ni-ryo i-shyamba umu-higi y-a-tem-ey-e-*(mo) igi-ti.*
 5.this is-5 5-forest 1-hunter 1S-PST-cut-APPL-PERF-LOC 7-tree
 'This is the forest in which the hunter cut the tree.'
- b. *Iki ni-cyo gi-ti umu-higi y-a-tem-ey-e mw' i-shymaba.*
 7.this is-7 7-tree 1-hunter 1S-PST-cut-APPL-FV LOC 5-forest
 'This is the tree that the hunter cut in the forest.' KR
- (59) a. *Kuno (ku-li) ku-mu-kati ni-kwo omu-hayi a-∅-khal-il-a mu-n-ju.*
 3.this 3-COP 3-3-bread that-3 1-hunter 1S-PST-cut-APPL-FV 18-9-house
 'This is the bread that the hunter cut in the house.'

- b. *Eyino (e-li) e-n-ju ni-yo omu-hayi a-∅-khal-il-a-mo*
 9.this 9-COP 9-9-house that-9 1-hunter 1S-PST-cut-APPL-FV-18O
ku-mu-kati
 3-3-bread

‘This is the house in which the hunter cut the bread.’

LBK

Table 10 summarizes the data for the locative applicative in the three languages. Most

<i>Language</i>	<i>Obj</i>	<i>WO</i>	<i>OM</i>	<i>Pass</i>	<i>Rel</i>
Chicheŵa	Loc	*	*	✓	✓
	Th	✓	✓	✓	✓
Kinyarwanda	Loc	✓	✓	✓	~
	Th	✓	✓	✓	✓
Lubukusu	Loc	✓	*	~	✓
	Th	✓	✓	~	✓

Table 10: Object Diagnostics for the locative applicative

notably, the object symmetry pattern for all three languages for the locative applicative differs from the benefactive applicative in Table 9. In Chicheŵa, interestingly, the locative object is restricted in word order and, in the dialect of the speakers consulted, it cannot be object-marked on the verb. With passivization and relativization, however, both the locative and thematic objects are unrestricted. Kinyarwanda is mostly symmetrical with both the locative and thematic objects being free in word order, object marking, and passivization. With relativization, however, the locative can only be extracted if a locative clitic appears on the verb. For Lubukusu, there is variation in the behavior of the different diagnostics. Word order and relativization are free, but object marking is not, as the locative object cannot be marked on the verb. Furthermore, in order to have either object as the subject of a passive, the locative clitic is obligatory.

3.3 Instrumental Applicatives

I turn now to the instrumental applicative. For Chicheŵa and Lubukusu, the word order is flexible. With Kinyarwanda, however, some speakers have indicated that they prefer the

theme to precede the instrumental applied object; for other speakers, both orders are acceptable. I notate this with a single question mark (?) in (61b).

- (60) a. *M-silikari a-na-phwany-ir-a kapu ndodo.*
 soldier 1S-PST-break-APPL-FV cup stick
 ‘The soldier broke the cup with a stick.’
- b. *M-silikari a-na-phwany-ir-a ndodo kapu.*
 soldier 1S-PST-break-APPL-FV stick cup
 ‘The soldier broke the cup with a stick.’ CHW
- (61) a. *Umw-ana y-a-men-esh-eje igi-kombe in-koni.*
 1-child 1S-PST-break-ISH-PERF 7-cup 9-stick
 ‘The child broke the cup with a stick.’
- b. ?*Umw-ana y-a-men-esh-eje in-koni igi-kombe.*
 1-child 1S-PST-break-ISH-PERF 9-stick 7-cup
 ‘The child broke the cup with a stick.’ KR
- (62) a. *Omw-ana k-a-tis-il-a si-kombe lu-sala.*
 1-child 1S-PST-break-APPL-FV 7-cup 11-stick
 ‘The child broke the cup with a stick.’
- b. *Omw-ana k-a-tis-il-a lu-sala si-kombe.*
 1-child 1S-PST-break-APPL-FV 11-stick 7-cup
 ‘The child broke the cup with a stick.’ LBK

For object-marking, Chicheŵa and Kinyarwanda permit both objects to be object-marked on the verb, provided in (63) and (64). In Lubukusu, on the other hand, the instrumental object cannot be object marked in (65). This is surprising as previous analyses predict that if there is an object that is blocked, it is the theme; in (65b), however, the instrumental object is the one that cannot be object marked.

- (63) a. *A-mayi a-na-u-phwany-ir-a ndodo.*
 2-mother 2S-PST-3O-break-APPL-FV stick
 ‘Mother broke it with a stick.’

- b. *A-mayi a-na-i-phwany-ir-a m-phika.*
 2-mother 2S-PST-7O-break-APPL-IMP 3-pot
 ‘Mother broke the pot with it.’ CHW
- (64) a. *Umw-ana y-a-ki-men-esh-eje in-koni.*
 1-child 1S-PST-7O-break-ISH-PERF 9-stick
 ‘The child broke it with the stick.’
- b. *Umw-ana y-a-yi-men-esh-eje igi-kombe.*
 1-child 1S-PST-9O-break-ISH-PERF 7-cup
 ‘The child broke the cup with it.’ KR
- (65) a. *Omw-ana a-∅-si-fun-il-a lu-sala.*
 1-child 1S-PST-7O-break-APPL-FV 11-stick
 ‘The child broke it with a stick.’
- b? *Omw-ana a-∅-lu-fun-il-a si-kombe.*
 1-child 1S-PST-11O-break-APPL-FV 7-cup
 ‘The child broke the cup with it.’ LBK

As for being the subject of a passive, Kinyarwanda is the only language where both objects are acceptable. In Chicheŵa, speakers’ default interpretation is that the subject of the sentence is the instrument. Namely, in (66a), there is a possible reading where the cup was used to break the stick. I return to this in §3.6, where I suggest that the insertion of the instrumental preposition *ndi* ‘with’ is used to disambiguate the reading, as shown in (66c). Lubukusu is asymmetrical here: the theme cannot be the subject of the passive.

- (66) a? *Kapu li-na-phwany-ir-idw-a ndodo.*
 cup S-PST-break-APPL-PASS-FV stick
 ‘The cup was broken with a stick.’
- b. *Ndodo u-na-phwany-ir-idw-a kapu.*
 stick 3S-PST-break-APPL-PASS-FV cup
 ‘The stick was used to break the cup.’
- c. *Kapu li-na-phwany-ir-idw-a *(ndi) ndodo.*
 cup S-PST-break-APPL-PASS-FV with stick
 ‘The cup was broken with a stick.’ CHW

- (67) a. *Igi-kombe cy-a-men-esh-ej-w-e* *in-koni na mw-ana.*
 7-cup 7S-PST-break-ISH-PERF-PASS-PERF 9-stick by 1-child
 ‘The cup was broken with a stick by the child.’
- b. *In-koni y-a-men-esh-ej-w-e* *igi-kombe na mw-ana.*
 9-stick 9S-PST-break-ISH-PERF-PASS-PERF 7-cup by 1-child
 ‘The stick was used to break the cup by the child.’ KR
- (68) a. *Si-kombe sj-a-fun-il-w-a* *lu-sala ne omw-ana.*
 7-cup 7S-PST-break-APPL-PASS-FV 11-stick by 1-child
 ‘The cup was broke with a stick by the child.’
- b. **Lu-sala lw-a-fun-il-w-a* *si-kombe ne omw-ana.*
 11-stick 11S-PST-break-APPL-PASS-FV 7-cup by 1-child
 ‘The stick was used to break the cup by the child.’ LBK

With relativization, all three languages are asymmetrical as in (69) to (71); in all cases, the theme is not permitted in an extracted position.

- (69) a. *Iyi ndi ndodo imene mwana a-na-phwany-ir-a kapu.*
 this is stick that child 1S-PST-break-APPL-FV cup
 ‘This is the stick that the child used to break the cup.’
- b. **Iyi ndi kapu imene mwana a-na-phwany-ir-a ndodo.*
 this is cup that child 1S-PST-break-APPL-FV stick
 Intended ‘This is the cup that the child broke with a stick.’ CHW
- (70) a. *Iyi ni-yo nk-oni mama y-a-men-esh-eje igi-kombe.*
 9.this COP-9 9-stick 1.mom 1S-PST-break-ISH-PERF 7-stick
 ‘This is the stick mom used to break the cup.’
- b. **Iki ni-cyo gi-kombe mama y-a-men-esh-eje in-koni.*
 7.this COP-7 7-cup 1.mom 1S-PST-break-ISH-PERF 9-stick
 Intended: ‘This is the cup that mom broke with the stick.’ KR
- (71) a. **Sino (si-li) si-kombe ni-syo omw-ana k-a-fun-il-a lu-sala.*
 7.this 7-is 7-cup COP-7 1-child 1S-PST-break-APPL-FV 11-stick
 Intended: ‘This is the cup that the child broke with the stick.’

- b. *Luno (lu-li) lu-sala ni-lwo omw-ana a-∅-fun-il-a si-kombe.*
 11.this 11-is 11-stick COP-11 1-child 1S-PST-break-APPL-FV 7-cup
 ‘This is the stick the child used to break the cup.’

<i>Language</i>	<i>Obj</i>	<i>WO</i>	<i>OM</i>	<i>Pass</i>	<i>Rel</i>
Chicheŵa	Inst	✓	✓	✓	✓
	Th	✓	✓	~	*
Kinyarwanda	Inst	✓	✓	✓	✓
	Th	?	✓	✓	*
Lubukusu	Inst	✓	??	*	✓
	Th	✓	✓	✓	*

Table 11: Objecthood diagnostics for the instrumental applicative

Table 11 summarizes the patterns of symmetry for the instrumental applicative. For Chicheŵa, word order and object marking are both symmetrical. With the passive, the default interpretation is that the subject is an instrument. Relativization is restricted, with only the instrumental object being able to be extracted, and this restriction with relative clauses, in fact, is shared across the three languages. For some speakers of Kinyarwanda, the instrumental object must follow the theme, but all speakers accept flexibility with the object marking and passivization. In Lubukusu, the theme cannot be the subject of a passive, while the instrument cannot appear as an object marker on the verb.

3.4 Morphological Causatives

Finally, I discuss the symmetry properties of morphological causatives, which, like applicatives, result in a ditransitive structure when used with transitive verbs. Note that Kinyarwanda is the only language with the causative-instrumental syncretism (cf. Chapter 4); Chicheŵa and Lubukusu have separate causative morphemes.

Starting with word order, Chicheŵa and Lubukusu are both symmetrical with respect to causatives, as in (72) and (74). In Kinyarwanda, however, speakers vary in the degree to which they prefer the objects to appear in a fixed order. Some prefer the causee to precede

the theme, while others accept either order. I indicate this variation as marginally grammatical in (73b).²⁰

- (72) a. *M-silikari a-na-meny-ets-a mw-ana khoma.*
 1-soldier 1S-PST-hit-CAUS-FV 1-child wall
 ‘The soldier made the child hit the wall.’
- b. *M-silikari a-na-meny-ets-a khoma mw-ana.*
 1-soldier 1S-PST-hit-CAUS-FV wall 1-child
 ‘The soldier made the child hit the wall.’ CHW
- (73) a. *Umw-arimu y-a-kubit-ish-ije in-dwanyi igi-kuta.*
 1-teacher 1S-PST-hit-ISH-PERF 9-soldier 7-wall
 ‘The teacher made the soldier hit the wall.’
- b. *?Umw-arimu y-a-kubit-ish-ije igi-kuta in-dwanyi.*
 1-teacher 1S-PST-hit-CAUS-PERF 7-wall 9-soldier
 ‘The teacher made the warrior hit the wall.’ KR
- (74) a. *Omw-ekesi a-∅-p-isy-a omu-khangarani li-sisi.*
 1-teacher 1S-PST-hit-CAUS-FV 1-warrior 5-wall
 ‘The teacher made the warrior hit the wall.’
- b. *Omw-ekesi a-∅-p-isy-a li-sisi omu-khangarani.*
 1-teacher 1S-PST-hit-CAUS-FV 5-wall 1-warrior
 ‘The teacher made the warrior hit the wall.’ LBK

In Chicheŵa and Lubukusu, only the causee object can appear as an object marker, as in (75) and (77) while in Kinyarwanda both objects can be object marked on the verb, as in (76).

- (75) a. *M-silikari a-na-mu-meny-ets-a khoma.*
 1-soldier 1S-PST-1O-hit-CAUS-FV wall
 ‘The soldier made him/her hit it.’

²⁰For the morphological causatives in Lubukusu, ungrammatical responses were sometimes mentioned as being awkward or dispreferred, but not categorically out; in other cases speakers outright rejected the sentences. A crucial difference was found with ingestive verbs, where the different objecthood diagnostics were unequivocally accepted (and an explanation for this is proposed in the next section). For future work, a controlled quantitative study with a Likert scale of acceptability, needs to be done to confirm the degree to which different verbs are (un)grammatical with different objecthood diagnostics with respect to causativization.

- b. **M-silikari a-na-li-meny-ets-a mw-ana.*
 1-soldier 1S-PST-5O-hit-CAUS-FV 1-child
 ‘The soldier made the child hit it.’ CHW
- (76) a. *Umw-arimu y-a-mu-kubit-ish-ije igi-kuta.*
 1-teacher 1S-PST-1O-hit-ISH-PERF 7-wall
 ‘The teacher made him/her hit the wall.’
- b. *Umw-arimu y-a-gi-kubit-ish-ije in-dwanyi.*
 1-teacher 1S-PST-7O-hit-CAUS-PERF 9-warrior
 ‘The teacher made the warrior hit it.’ KR
- (77) a. *Omw-ekesi a-∅-mu-p-isy-a li-sisi.*
 1-teacher 1S-PST-1O-hit-CAUS-FV 5-wall
 ‘The teacher made him/her hit the wall.’
- b. **Omw-ekesi a-∅-li-p-isy-a omu-khangarani.*
 1-teacher 1S-PST-5O-hit-CAUS-FV 1-warrior
 ‘The teacher made the warrior hit it.’ LBK

The passivization data parallel the object-marking data. In both Chicheŵa and Lubukusu in (78) and (80), only the causee can be the subject of a passive. In the Kinyarwanda example in (79), however, either object can be the subject.²¹

- (78) a. *Mw-ana a-na-mang-its-idw-a nyumba ndi a-mfumu.*
 1-child 1S-PST-build-CAUSE-PASS-FV house by 2-chief
 ‘The child was made to build the house by the chief.’
- b. **Nyumba i-na-mang-its-idw-a mw-ana ndi a-mfumu.*
 3.house 3S-PST-build-CAUSE-PASS-FV 1-child by 2-chief
 ‘The house was made to be built by the child by the chief.’ CHW
- (79) a. *In-dwanyi y-a-kubit-ish-ij-w-e igi-kuta na mw-arimu.*
 9-soldier 9S-PST-hit-ISH-PERF-PASS-PERF 7-wall by 1-teacher
 ‘The soldier was made to hit the wall by the teacher.’

²¹The verb *ku-menya* ‘to hit’ in Chicheŵa was found to be odd in this construction for speakers, and neither object was sensible as the subject on the intended reading. I use *khu-manga* ‘to build’ to demonstrate the grammaticality of passives.

- b. *Igi-kuta cy-a-kubit-ish-ij-w-e* *in-dwanyi na mw-arimu.*
 7-wall 7S-PST-hit-ISH-PERF-PASS-PERF 9-warrior by 1-teacher
 ‘The wall was made to be hit by the warrior by the teacher.’ KR
- (80) a. *Omu-khangarani a-∅-p-isy-ibw-a* *li-sisi ne omw-ekesi.*
 1-warrior 1S-PST-hit-CAUS-PASS-FV 5-wall by 1-teacher
 ‘The warrior was made to hit the wall by the teacher.’
- b. **Li-sisi ly-a-p-isy-ibw-a* *en-ju ne omw-ekesi.*
 5-wall 5S-PST-hit-APPL-PASS-FV 9-house by 1-teacher
 ‘The wall was made to be hit by warrior by the teacher.’ LBK

With relativization, all three languages are symmetrical, as in (81) to (83).²²

- (81) a. *Uyu ndi mw-ana a-mene m-silikari a-na-meny-ets-a khoma.*
 1.this COP 1-child 1S-that 1-soldier 1S-PST-hit-CAUS-FV 5.wall
 ‘This is the child that the soldier used to hit the wall.’
- b. *Ili ndi khoma li-mene m-silikari a-na-meny-ets-a mw-ana.*
 5.this COP 5.wall 5-that 1-soldier 1S-PST-hit-CAUS-FV 1-child
 ‘This is the wall that the soldier made the child hit.’ CHW
- (82) a. *Uyu ni-we mw-ana umu-yobozi y-∅-ubak-ish-ije in-zu.*
 1.this COP-1 1-child 1-chief 1S-PST-build-ISH-PERF 9-house
 ‘This is the child that the chief made build the house.’
- b. *Iyi ni-yo n-zu umu-yobozi y-∅-ubak-ish-ije mw-ana.*
 9.this COP-9 9-house 1-chief 1S-PST-build-CAUS-PERF 1-child
 ‘This is the house that the chief made the child build.’ KR
- (83) a. *Elino (li-li) li-sisi ni-lyo omw-alimu a-∅-p-isy-a omw-ana.*
 5.this 5-COP 5-wall that-5 1-child 1S-PST-hit-CAUS-FV 1-child
 ‘This is the wall that the teacher made the child hit.’

²²The Kinyarwanda data in (82) are replaced with the verb *k-ubaka* ‘to build’ because the causative of *gu-kata* ‘cut’ does not have a causative reading (cf. Chapter 4).

- b. *Oyuno (a-li) omw-ana ni-ye omw-alimu a-∅-p-isy-a li-sisi*
 1.this 1-COP 1-child that-1 1-teacher 1S-PST-hit-CAUS-FV 5-wall

‘This is the child that the teacher made hit the wall.’

LBK

<i>Language</i>	<i>Obj</i>	<i>WO</i>	<i>OM</i>	<i>Pass</i>	<i>Rel</i>
Chicheŵa	Causee	✓	✓	✓	✓
	Theme	✓	*	*	✓
Kinyarwanda	Causee	✓	✓	✓	✓
	Theme	?	✓	✓	✓
Lubukusu	Causee	✓	✓	✓	✓
	Theme	✓	*	*	✓

Table 12: Object diagnostics for the morphological causative

Table 12 summarizes symmetry with the morphological causative. Chicheŵa and Lubukusu pattern the same: word order is free and extraction in relative clause formation is available to both objects; the theme in both languages, however, is restricted in object marking and passivization. In Kinyarwanda, all diagnostics are symmetrical except for word order, where the causee is preferred to precede the theme.

3.5 Results

The data from the controlled comparative study show that there is considerable variation in object symmetry both across languages, thematic roles, and even diagnostics within a single language. For example, it is ungrammatical to object-mark the theme or have it as the subject of a passive in a benefactive sentence in Chicheŵa, while this acceptable in both Kinyarwanda and Lubukusu. Conversely, in Lubukusu, the theme cannot be the subject of a passive in instrumental applicative sentences, while this is fine in Chicheŵa, which very clearly shows that for any of the analyses discussed in §2 that tie generalizations regarding symmetry to specific thematic roles will be incapable of generalizing that pattern to a different language. At times, the data are paradoxical: while benefactives are symmetrical in Lubukusu and Kinyarwanda, they are asymmetrical in Chicheŵa; while instrumental applicatives are mostly symmetrical in Chicheŵa and Kinyarwanda, they are asymmetri-

cal in Lubukusu. This variation is profoundly problematic for the generalizations made in previous work.

However a more fundamental problem emerges from the data discussed in previous sections. While it has been tempting to tie the different diagnostics to a single parameter of variation, a more complete comparison of the languages shows that thematic role is not the only factor in determining symmetry. In other words, objecthood diagnostics do not all point to the same diagnoses for all objects. However, it is worth noting that certain generalizations emerge. The most salient generalization is that with the benefactive and morphological causatives in Tables 9 and 12, the beneficiary and causee objects consistently behave as true objects, while the thematic object varies among the languages. Because beneficiaries and causees are also both prototypically animate, this could suggest that the animacy of the object noun is relevant in determining its objecthood status at least with applied objects. While I do not pursue an in-depth discussion of these facts here, I do propose that future work must move away from exclusively syntactic explanations of object symmetry, especially in a framework which attempts to derive variation from a single parameter.

Instead, I conjecture that multiple factors conspire to derive the status of specific objects in a given applicative sentence with respect to a particular diagnostic, as is widely assumed to be the case for other language families. For example, in English, it has been argued that argument realization patterns of the dative alternation are affected by various factors such as verb class (Rappaport Hovav & Levin 2008, Beavers 2011a), information structure (Goldberg 2014), or a mix of various factors such as noun animacy, NP weight, pragmatics, etc. (Bresnan et al. 2007). For Bantu languages, I pose that similarly, components such as verb class, information structure, discourse, thematic role, and animacy of the object argument conspire to determine whether an argument may appear in a particular position (e.g. the subject of a passive verb) in a particular objecthood diagnostic in a given language. Crucially, I doubt that any of these factors universally determine all diagnostics across all

languages (as shown in detail in this section). Instead, a better approach is to analyze the nature of particular diagnostics within a particular language in their own right. This has been successful for other language families, and my hope is that future work on applicative morphology in Bantu can pursue the broader scope of the relevant components that affect the syntactic status of applied object across different languages.

3.6 On Oblique Marking and Resumptive Pronouns

In addition to the issues discussed in the previous section, another assumption in research on object symmetry is that the applicative is the only grammatical means at play in licensing the applied object and its objecthood properties, and as such, the grammatical properties of this putative object can be compared to the thematic object of the verb. The data, however, are not quite so categorical, and the use of other grammatical tools muddies this idealized picture. Two such grammatical features are the instrumental oblique in Chicheŵa and the locative clitics in Kinyarwanda and Lubukusu.

It was noted above in (66) that the theme in Chicheŵa *can* be the subject of a passive if the *in situ* instrumental object is marked with the instrumental preposition *ndi* ‘with’. An example is given in (84), where the instrumental preposition *ndi* ‘with’ *and* the applicative together license the instrumental object *ndodo* ‘stick’ when the theme has been promoted to subject position of a passive.

- (84) *Kapu li-na-phwany-ir-idw-a* **(ndi) ndodo.*
 cup S-PST-break-APPL-PASS-FV with stick
 ‘The cup was broken with a stick.’

Data of this type are crucial for the discussion of object symmetry; the data in (84) show that there is not an issue of the theme being the subject of the passive, but rather that the ungrammaticality of the sentence in (66) above arises because of the lack of the oblique marker.

Several explanations are possible for these facts, but I only hint at them here. One explanation is that sentences of the type in (84) are derived from separate argument structures than from ones where there is just an applicative and an applied object, and in some way, this alternative structure results in the theme being blocked in the structure where the instrument is a full object (namely, not licensed with an oblique). However, such a view fails to capture the fact that the applicative is present in sentences like (84) as well as cases where there is not an oblique.

Another possible approach is to analyze the oblique *ndi* ‘with’ in Chicheŵa as in the beginning stages of grammaticalization to becoming an instrumental class marker, similarly to the locative prefixes discussed for Kinyarwanda in Chapter 3. While it is not yet a fully grammaticalized class marker (evidenced by the fact that it does not show any kind of agreement), the ability to co-occur with the applicative in (84) suggests that does not have its fully object-licensing function. Thus in cases like (84), perhaps the subject of the passive is interpreted by default as the instrument (for whatever reason), and given the fact that in instrumental applicatives both the thematic and applied objects are inanimate, both are potentially the instrument. In order to disambiguate, the preposition (or grammaticalized class marker) *ndi* ‘with’ is required when the subject of the passive is not the instrument.

This fits with the various functionalist analyses of applicatives, which assume that the function of an applicative is to place an argument in a more topical or more discourse-salient position (Givón 1983, Rude 1986, Donohue 2001, Peterson 2007). If the function of an applicative is to place a non-core argument in a position of more discourse salience, it is unexpected for the thematic object to be the subject of a passive (namely, in a more discourse-salient position) when there is an applied object. In order to overcome this mismatch, Chicheŵa redundantly marks the applied object with an oblique (or potential instrument class marker, as the case may be).²³

²³A related question is the function of the applicative in Chicheŵa. As shown in Chapter 3, applicatives do not always have the function of licensing new objects, and thus in theory the putative instrumental applicative may not be licensing an instrumental object at all in cases like (84), but rather performing some other function. If this were the case, the oblique would be obligatory in order to

A related question arises with the locative object markers in Lubukusu and Kinyarwanda. When the locative applied object is extracted (through relative clause formation or a passive), the locative clitic is required. Recall, for example, data such as that discussed above in (56b) and (58a), repeated in (85) and (86), respectively.

- (85) *Mu-n-ju mw-a-khal-il-w-a-mo ku-mu-kati ne omu-hayi.*
 18-9-house 18-PST-cut-APPL-PASS-FV-18O 3-3-bread by 1-hunter
 ‘In the house was cut the bread by the hunter.’ LBK
- (86) *Iri ni-ryo i-shyamba umu-higi y-a-tem-ey-e-*(mo) igi-ti.*
 5.this is-5 5-forest 1-hunter 1S-PST-cut-APPL-PERF-LOC 7-tree
 ‘This is the forest in which the hunter cut the tree.’ KR

The use of the resumptive locative clitic parallels the question of use of the oblique *ndi* ‘with’ in Chicheŵa. While it is not grammatical to have the locative as a passive subject as in (85) or extracted as in (86) without the locative, the use of the locative clitic permits this construction. From the perspective of object symmetry, this is evidence against the dominant methodology of tying thematic role to specific symmetry patterns; there is nothing wrong with the locative arguments being extracted, but to do so they require a locative clitic on the verb.

Note that in the Kinyarwanda sentence in (86), the locative preposition is not present in the extracted DP. In this case, I assume that the locative clitic is obligatory to disambiguate that the extracted argument is a location. With the Lubukusu case in (85), it is less clear what the appropriate analysis is. Of particular interest is the fact that not only is the locative clitic obligatory, but that the locative subject also shows subject agreement with the verb. While I leave the explanation of this fact for future research, it is crucial to note that from the perspective of object symmetry, these nuances in the data have been largely ignored, allowing the literature to discuss a highly idealized set of facts that do not reflect the true complexity of the data.

license an instrument. However, the object-adding function is clearly present in the cases where the instrumental object is the subject of the passive, which problematizes this view. I leave the resolution of this issue to future research.

3.7 Other Syntactic Tests for Object Relations

So far, this chapter has argued against the claim that there is a universal link between the syntax and semantics of applicatives, showing that thematic role does not universally determine the symmetry facts across languages nor across objecthood diagnostics. In this subsection I set aside the issue of semantic role, arguing that there are purely syntactic reasons to discount the claim that symmetry derives from a single point of variation in the syntax, showing specifically that there is uniformity in the asymmetry of structural diagnostics such as c-command relations and ellipsis facts that are orthogonal to the symmetry question of the diagnostics discussed above. This is strong evidence that the object symmetry facts cannot reduce to a single point of syntactic variation, since syntactic diagnostics fail to pattern uniformly with the objecthood diagnostics in the previous section.

First, I review data from Ngonyani & Githinji (2006), who show that while Kikuyu (E.51; Kenya) and Chingoni (N.12; Tanzania and Mozambique) differ in several objecthood diagnostics, VP-ellipsis facts suggest they have a similar syntactic structure in applicatives. I then make a similar point from Kinyarwanda, where despite almost categorical symmetry in benefactive applicatives with respect to the four diagnostics presented above, c-command is restricted and asymmetric.

Ngonyani & Githinji (2006) use verb ellipsis to diagnose syntactic structure, showing that the VP for applied benefactive sentences are the same regardless of the symmetry patterns with other objecthood diagnostics — i.e. passivization, object marking, and word order.²⁴ Specifically, verb ellipsis facts in Kikuyu (a “symmetrical” language spoken in Central Kenya) are the same as the verb ellipsis facts in Chingoni (an “asymmetrical” language spoken in Tanzania). Consider the data in (87) and (88), which provides passivization diagnostics for Chingoni and Kikuyu, respectively.

²⁴In the discussion that follows, Ngonyani and Githinji assume that ellipsis follows from configurational structure. If one does not make this assumption, the data presented from Chingoni and Kikuyu still indicate a difference in patterns of symmetry between ellipsis and other symmetry diagnostics.

- (87) a. *Kuku a-m-kamul-i m-geni mene.*
 1grandfather 1S-1O-hold-APPL 1-guest 9-goat
 ‘Grandpa held/gave a goat for grandpa.’
- b. *M-geni a-kamul-i-w-i mene.*
 1-guest 1S-hold-APPL-PASS-PF 9-goat
 ‘The guest had a goat held/given to him’.
- c. **Mene ya-kamul-i-w-i m-geni.*
 9-goat 9S-hold-APPL-PASS-PF 1-guest
 ‘The goat was held/given to the guest.’ (Ngonyani & Githinji 2006:38,(12))
- (88) a. *Mũ-geni a-ra-gũr-ĩ-ire ci-ana mũ-bira.*
 1-guest 1S-PRG-buy-APPL-PRF 8-child 3-ball
 ‘The guest bought children a ball’.
- b. *Ci-ana ci-ra-gũr-ĩ-ir-w-o mũ-bira nĩ mũ-geni.*
 8-child 8S-PRG-buy-APPL-PF-PASS-FV 3-ball by 1-guest
 ‘The children were bought ball by the guest’.
- c. *Mũ-bira ũ-ra-gũr-ĩ-ir-w-o ci-ana nĩ mũ-geni.*
 3-ball 8-PRG-buy-APPL-PF-PASS-FV 8-child by 1-guest
 ‘The ball was bought for the children by the guest.’
- (Ngonyani & Githinji 2006:38,(11))

The data in (87) and (88) show that passives differ between the two languages: in Chin-goni, the theme cannot appear as the subject of a passive, while in Kikuyu, both objects can appear as subjects of a passive (and the same symmetry patterns are found for object marking and word order diagnostics). Using a different diagnostic, developed by Ngonyani (1996), they show that both languages behave the same with respect to VP ellipsis, which suggests the same underlying configurational structure in both. Using several diagnostics for VP ellipsis (such as adverbial ellipsis, appearance in syntactic islands, and the deletion of idiom chunks), they propose the following analysis of VP deletion.

- (89) a. *Amina i-gul-a nyumba mewa.*
 Amina PR-buyFV 9.house also
 ‘Amina is buying a house too.’

(Ngonyani & Githinji 2006:44,(28))

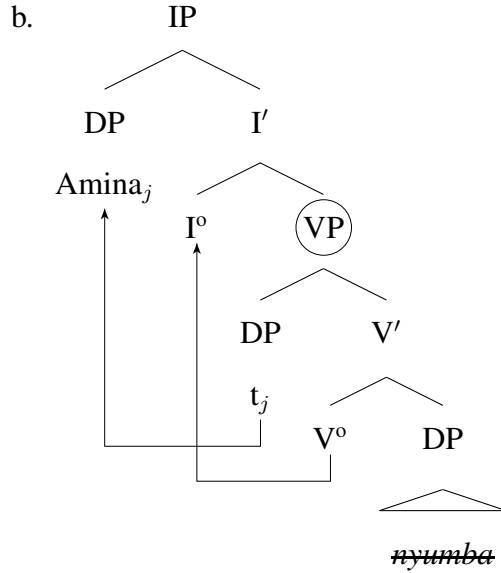

In this analysis, the verb moves out of the VP before deletion, while the object remains *in situ* and is deleted. For clarity in trees, the VP nodes eligible for deletion are circled. With applicative sentences, they point out that in principle there are two possible structures — one for symmetrical object languages and one for asymmetrical object languages, provided in (90).

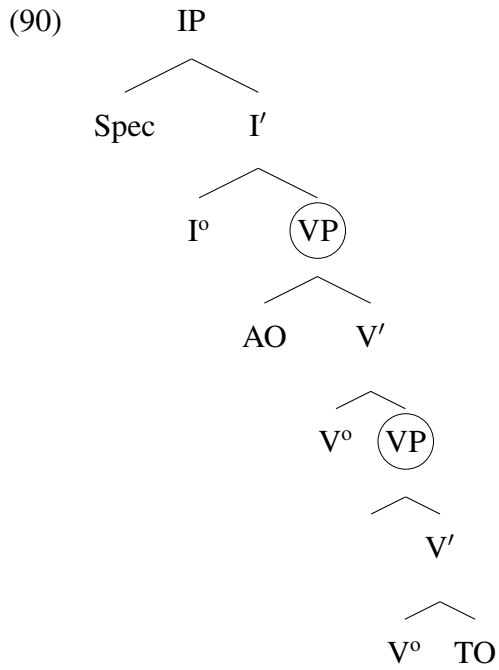

In this structure, the applied object c-commands the thematic object, capturing the asymmetric word order such as in the data from Chingoni in (87), where the applied object must precede the direct object in word order and is the only object accessible to A-movement. A symmetrical language would, in principle, have another available structure, where the direct object c-commands the applied object.

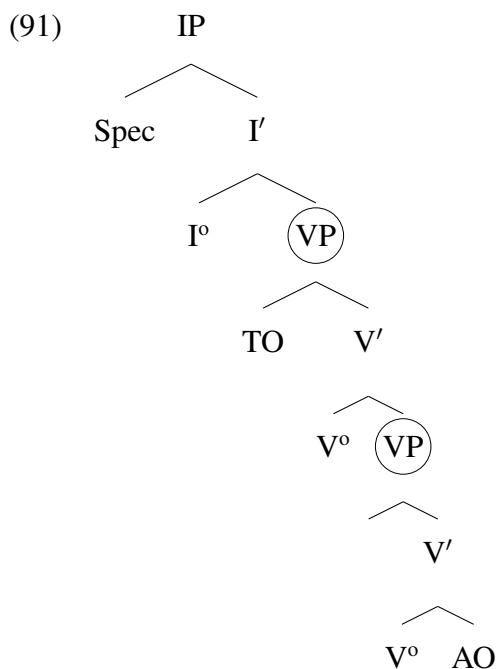

The trees in (90) and (91) make different predictions about the possible kinds of ellipsis that are possible. On their analysis, both VPs are possible targets of ellipsis. For a symmetrical language, both structures in (90) and (91) are possible, and several different ellipsis facts should be observed: deleting the lower VP in either tree would provide a sentence where only the lower object (applied or thematic) is elided. When the higher VP is targeted for ellipsis, both objects are be elided. In an asymmetric language, only the tree in (90) is possible, and therefore, there should never be ellipsis that only deletes the applied object. What they find, however, is that both languages have the same facts with respect to VP ellipsis: either both objects can be deleted or just the thematic object can be deleted by itself.

- (92) a. *Mū-geŋi nĩ-a-ra-gũr-ĩr-a* *ci-ana kĩ-heo ona nyina*
 1-guest FOC-1S-PRG-buy-APPL-FV 8-child 7-gift and 9-mother
nĩ-a-ra-ci-gũr-ĩr-a ~~*kĩ-heo*~~.
 FOC-1S-PRG-8O-buy-APPL-FV 7-gift
 ‘The guest is buying presents for the children, and the mother is, too.’ (Kikuyu)

- b. *M-~~geni~~ a-ka-gul-i va-ndu vi-dengu na mawu a-ka-gul-i*
 1-guest 1S-RP-buy-APPL 2-person 8-basket and 1-mother 1S-RP-buy-APPL
v-ana ~~vi-dengu~~ mewa.
 2-child 8-basket also
 ‘The guest bought baskets for the people, and the mother did, too.’ (Chingoni)
 (Ngonyani & Githinji 2006:46,(32))

- (93) a. *Mū-~~geni~~ nĩ-a-ra-gūr-ĩr-a ci-ana kĩ-heo, ona nyina ~~ei-ana~~*
 1-guest FOC-1S-PRG-buy-APPL-FV 8-child 7-gift and 9-mother 8-child
kĩ-heo onake.
 7-gift also
 ‘The guest is buying the children a gift, and the mother is doing so, too.’
 (Kikuyu)

- b. *M-~~geni~~ a-ka-gul-i va-ndu vi-dengu na mawu a-ka-gul-i*
 1-guest 1S-RP-buy-APPL 2-person 8-basket and 1-mother 1S-RP-buy-APPL
~~va-ndu~~ vi-dengu mewa.
 2-person 8-basket also
 ‘The guest bought baskets for the people, and the mother did, too.’ (Chingoni)
 (Ngonyani & Githinji 2006:49,(36))

Crucially, the applied object cannot be elided by itself in either language.

- (94) a. **Mū-~~geni~~ nĩ-a-ra-gūr-ĩr-a ci-ana ma-buku na nyina*
 1-guest FOC-1S-PRG-buy-APPL-FV 8-child 6-book and 9-mother
nĩ-a-ra-gūr-ĩr-a ~~ei-ana~~ ma-buku.
 FOC-1S-PRG-buy-APPL-FV 8-children 6-book
 ‘The guest is buying children books, and the mother is buying (them) books,
 too’. (Kikuyu)

- b. **M-~~geni~~ a-ka-gul-i va-ndu vi-dengu na mawu a-ka-gul-i*
 1-guest 1S-RP-buy-APPL 2-person 8-basket and 1-mother 1S-RP-buy-APPL
~~va-ndu~~ vi-dengu mewa.
 2-person 8-basket also
 ‘The guest bought baskets for the people, and the mother did too’. (Chingoni)
 (Ngonyani & Githinji 2006:47-48,(34a),(35a))

The data in (92) – (94) show that ellipsis in both Chingoni and Kikuyu behaves the same:

either the thematic object can be deleted by itself or both objects can be deleted together. What is not permitted in either language is elision of just the applied object to the exclusion of the thematic object. Assuming that the thematic object c-commands the applied object, the tree in (91) makes false predictions for the ellipsis facts. Assuming that objecthood diagnostics are tied to configurational structure, the symmetry found in Kikuyu suggests that the structure in (91) is possible. However, this structure also predicts that elision of the lower VP should allow the applied object to be elided in isolation, which is not borne out. These facts are problematic for theories that rely on configurational asymmetries between the objects to capture the objecthood asymmetries (e.g. Marantz 1993, Pylkkänen 2008, McGinnis 2001, Jeong 2007).

In addition to the ellipsis facts, a similar line of reasoning can be drawn from Kinyarwanda, where despite the fact that applied and thematic objects which are generally symmetrical for all of the traditional diagnostics, c-command relations, which are configurational in nature, are uniformly asymmetrical. For example, in (95a), the applied object can bind into the thematic object, but the opposite is not possible, as in (95c).²⁵

- (95) a. *N-a-juguny-iy-e* *huri mu-gabo uru-funguzo rwe.*
 1SG-PST-throw-APPL-PERF every 1-man 11-key 11-his
 ‘I threw each man his key.’
- b. **N-a-juguny-iy-e* *im-funguzo ze huri mu-gabo.*
 1SG-PST-throw-APPL-PERF 10-key 10.his every 1-man
 ‘I threw his keys to each man.’
- c. **N-a-juguny-iy-e* *huri ru-funguzo umu-gabo wayo.*
 1SG-PSTthrow-APPL-PERF every 11-key 1-man 1-its
 ‘I threw each key to its man.’
- d. **N-a-jugun-iy-e* *umu-gabo w-ayo huri rufunguzo.*
 1SG-PSTthrow-APPL-PERF 1-man 1-its every key
 ‘I threw every key to its man.’

²⁵The plural of the class 11 noun *urufunguzo* ‘key’ is the class 10 *imfunguzo* ‘keys’.

In (96a), a similar situation is found with question words, where only the applied object can be fronted in a double question.

- (96) a. *Ni nde w-a-juguny-iy-e uru-he ru-funguzo?*
 is who 2SGS-PST-throw-APPL-IMP 11-which 11-key
 ‘Who did you throw which key?’
- b. **Ni uru-he ru-funguzo w-a-juguny-iy-e nde?*
 is 10-which 10-key 2SGS-PST-throw-APPL-PERF who
 ‘Which key did you throw to who?’

Given the assumptions in standard GB/Minimalist frameworks, these data indicate that the applied object asymmetrically c-commands the theme. Other diagnostics in Kinyarwanda — such as passivization, object marking, and word order — are generally symmetrical (cf. the discussion above). Similar to the situation in the data from Ngonyani & Githinji (2006), the c-command facts require asymmetrical c-command, while the object status diagnostics suggests symmetrical or variable c-command.

This section has shown that ellipsis facts from Gikuyu and Chingoni as well as the c-command diagnostics from Kinyarwanda are orthogonal to other traditional objecthood diagnostics in the literature. I take this as further evidence against analyzing symmetry facts as deriving from a single point of syntactic variation. Specifically, this section showed that despite symmetry in other diagnostics such as being the subject of the passive, etc., c-command and VP ellipsis require the applied object to c-command the thematic object. This means that symmetry cannot be reduced to a single point of syntactic variation in the same way that it cannot be reduced to variation in thematic role, as the syntactic diagnostics show further variegation in their behavior with object symmetry.

4 The Effect of Verb Meaning on Symmetry

I have argued that syntactic structure is not universally correlated with semantics and that the thematic role of an applicative cannot derive the symmetry properties for a specific lan-

guage, and I proposed that several interrelated factors determine symmetry on a language-by-language basis. In this section, I suggest that verb meaning is another point of variation that has not been discussed in previous literature. By and large in the data I collected, verb class was not relevant in determining object symmetry, except for in the case of caused ingestive verbs in Lubukusu. Specifically, while the general pattern tends towards asymmetry with morphological causative in Lubukusu (summarized in Table 12 above), ingestive verbs show symmetry.

It is important to point out that the data for the symmetry facts with these examples need a special qualification. Many speakers conveyed in elicitations that the dispreference for certain symmetry diagnostics with morphological causatives relates to a cognitive difficulty in processing the diagnostic, and were often unconvinced of their judgments for other verbs although the trends suggested asymmetry. Crucially, however, ingestive verbs were always judged acceptable without pause or deliberation. To the degree to which caused ingestives are clearly symmetrical while other verbs are not, this is suggestive evidence that verb meaning is a component of what determines symmetry. In this section, I lay out a tentative analysis of why ingestive verbs show this seeming preference for symmetry, building on the fact that from a typological standpoint, ingestive verbs often behave distinctly from other verbs under causativization in several languages (Masica 1976, Amberber 2002, Næss 2007, 2009, Krejci 2012). I propose that the symmetry that is found with these verbs in Lubukusu arises from the same properties that underlie the distinctive behavior in other languages; namely, following Krejci (2012), I analyze ingestive verbs as inherent reflexives wherein a causer causes himself or herself to ingest something, and causation of ingestive verbs as a delinking of the causer from the ingester. This has the effect of making caused ingestives into lexical ditransitive verbs, unlike other causativized verbs where causativization adds a wholesale new causer subject. This distinction provides a starting point for understanding the difference in behavior of ingestive verbs with respect to certain object

symmetry diagnostics.

As was discussed in the §3.4, the morphological causative is asymmetrical with respect to object marking and passivization. For example, the verb *khu-pa* in (97) is asymmetrical with respect to passivization; only the causee can be the subject of the passive, as in (98a).

- (97) *Omw-ekesi* \emptyset -*a-p-isy-a* *omu-khangarani li-sisi*.
 1-teacher 1S-PST-hit-CAUS-FV 1-warrior 5-wall
 ‘The teacher made the warrior hit the wall.’

- (98) a. *Omu-khangarani* \emptyset -*a-p-isi-bw-a* *li-sisi ne omw-ekesi*.
 1-warrior 1S-PST-hit-CAUS-PASS-FV 5-wall by 1-teacher
 ‘The warrior was made to hit the wall by the teacher.’

- b? *Li-sisi ly-a-p-isi-bw-a* *omu-khangarani ne omw-ekesi*.
 5-wall 5S-PST-hit-CAUS-PASS-FV 1-warrior by 1-teacher
 ‘The wall was made to be hit by the warrior by the teacher.’

The data in (98) suggest asymmetry in passivization with the verb *khu-pa* ‘to hit’. With ingestive verbs as in (99), on the other hand, the pattern in passivization is symmetrical; both objects can appear as the subject of the passive, as shown in (100).

- (99) *Mama Leo* \emptyset -*a-nyw-esy-a* *Kyle kamalwa*.
 Mama Leo 1S-PST-drink-CAUS-FV Kyle beer
 ‘Mama Leo made Kyle drink the beer.’

- (100) a. *Kyle* \emptyset -*a-nyw-esy-ebw-a* *kamalwa ne Mama Leo*.
 Kyle 1S-PST-drink-CAUS-PASS-IMP beer by Mama Leo
 ‘Kyle was made to drink the beer by Mama Leo.’

- b. *Kamalwa k-a-nyw-esy-ebw-a* *Kyle ne Mama Leo*.
 beer 6S-PST-drink-CAUS-PASS-IMP Kyle by Mama Leo
 ‘The beer was made to be drunk by Kyle by Mama Leo.’

The difference in behavior of the two verbs in (98) and (100) suggest that there is verb-specific variation in the ability to have the theme as the subject of a passive; while the theme object of *khu-nywa* ‘to drink’ can be the subject of the passive, the theme of the verb *khu-pa* ‘to hit’ cannot. The pattern for *khu-pa* ‘to hit’ in (98) is the observed pattern with most

verbs, while the pattern found with *khu-nywa* ‘to drink’ in (100) is the exception, occurring only with other ingestive verbs, such as *khu-lia* ‘to eat’. It is worth noting that other works have claimed that the Lubukusu causative is symmetrical, based on data only using the verb *khu-lia* ‘to eat’, as in Baker et al. (2012). In their paper, they are concerned with how personal pronouns affects symmetry, and there is no intention to make a larger claim about the origins of symmetry. However, from a broader perspective, these data suggest that semantic verbs classes behave differently with respect to object symmetry diagnostics.

Cross-linguistically, the class of ingestive verbs has been noted in several languages to have exceptional properties under causativization. For example, in Hindi there are two morphological causatives, and both can be used with any verb. However, transitivity affects the reading that comes with the different morphemes. With intransitive verbs, the suffix *-aa* has a direct causative reading, while the suffix *-waa* has an indirect causative reading. With (di)transitive verbs, however, there is no meaning difference between the two. Consider, for example, the intransitive verb *uth* ‘to rise, get up’ and the transitive *kar* ‘to do’ (Masica 1976:46).

(101) Intransitive Verb : *uth* ‘to rise, get up’

- a. *uth* ‘*x* rise, get up’
- b. *uthaa* ‘*x* raise *y*, *x* pick up *y*’
- c. *uthwaa* ‘*x* have *y* rise’

(102) Transitive Verb : *kar* ‘to do’

- a. *kar* ‘*x* do *y*’
- b. *karaa* ‘*w* have *x* do *y*’
- c. *karwaa* ‘*w* have *x* do *y*’

(Hindi)

In (101), the directness of causation *uth* ‘rise, get up’ differs depending on which morpheme is used; in (102), however, both causative suffixes have the same indirect reading. Despite

their syntactic transitivity, ingestive verbs therefore pattern with intransitive verbs (Masica 1976:46).

- (103) a. *khaa* ‘*x* eat *y*’
 b. *khilaa* ‘*x* feed *y* to *z*’
 c. *kilwaa* ‘*w* have *x* feed *y* to *z*’
- (104) a. *pīi* ‘*x* drink *y*’
 b. *pīlāa* ‘*x* give a drink (*y*) to *z*’
 c. *pīlwāa* ‘*w* have *x* give a drink (*y*) to *z*’ (Hindi)

For the verbs *khaa* ‘to eat’ and *pīi* ‘to drink’, the use of the different causatives corresponds to direct and indirect readings in the same way that intransitive verbs distinguish between the two.²⁶

Another example comes from Amharic, which also has two distinct causatives *a-* and *as-*. The causative *a-* is reserved for intransitives, while *as-* can attach to both intransitive and transitive verbs. Consider for example the data below, which show that while the intransitive verbs in (105) permit causativization with the prefix *a-* in the corresponding data in (106), the transitive verb *k’wərrət’ə* ‘cut’ cannot.

- (105) a. *k’omə* ‘stand (intr)’
 b. *k’əllət’ə* ‘melt (intr)’
 c. *k’wərrət’ə* ‘cut’
- (106) a. *a-k’omə* ‘stand (tr)’
 b. *a-k’əllət’ə* ‘melt (tr)’
 c. **a-k’wərrət’ə* ‘cut’ (Amharic; Amberber 2002:2,(2))

The prefix *as-* on the other hand, can appear with both transitives and intransitives:

²⁶Other verbs that follow this pattern are “metaphorical” ingestives, such as *sun* ‘hear’, *samajh* ‘understand’, *siikh* ‘learn’, *paṭh* ‘read’ and *deekh* ‘see’ (Masica 1976:46-49).

- (107) a. *mət't'a* ‘come’
 b. *kʷərrət'ə* ‘cut’
- (108) a. *as-mət't'a* ‘make *x* come’
 b. *as-kʷərrət'ə* ‘make *x* cut *y*’ (Amharic; Amberber 2002,2,(3))

The intransitive verb *mət't'a* ‘come’ as well as the transitive verb *kʷərrət'ə* ‘cut’ are both able to appear with the causative *as-* in (108).

Given that the verb *bəlla* ‘eat’ is transitive, it is expected that it should permit the causative prefix *as-*, which is borne out in (109).

- (109) *Aster ləmma-n dabbo as-bəlla-čč-iw.*
 Aster Lemma-ACC bread CAUS-eat-PF-3F-3MO
 ‘Aster made Lemma eat some bread.’ (Amharic; Amberber 2002:3,(4))

What is not predicted based on the transitivity of the verb is that it may also appear with the prefix *a-*, but this morpheme can, in fact, be used with *bəlla* ‘to eat’, as in (110).

- (110) *Aster ləmma-n dabbo a-bəlla-čč-iw.*
 Aster Lemma-ACC bread CAUS-eat-PF-3F-3MO
 ‘Aster fed Lemma some bread.’ (Amharic; Amberber 2002:3,(5))

In Amharic, as with Hindi, ingestive verbs pattern with intransitive verbs, despite their syntactic transitivity.²⁷

In both Hindi and Amharic, ingestive verbs exceptionally causativize with a grammatical means that is generally reserved for a less-transitive class of verbs, and in fact, several genetically unrelated languages show comparable patterns, such as Malayalam (Mohan 1983:105-106), Berber (Guerssel 1986:36ff), Tariana (Aikhenvald 2000), Jarawara (Dixon 2000), Cora (Vasquez Soto 2002), among others.²⁸ It appears that something about the self-directed nature of eating events affects the categorization of transitivity of ingestive verbs

²⁷A limited set of other verbs pattern with *bəlla* ‘to eat’: *t'ət't'a* ‘drink’, *lasə* ‘lick’, *t'əba* ‘suck’, *k'əmməsə* ‘taste’, *lək'k'əmə* ‘pick up’, *t'wərrəsə* ‘take a mouthful’, *wat'ə* ‘eat large mouthfuls of grain’, and *gat'ə* ‘graze’ (Amberber 2002:3). All involve some sort of reflexive action of the subject acting on its own body.

²⁸See Nedjalkov & Silnitsky (1973), Shibatani (2002), Shibatani & Pardeshi (2002), Dixon (2000) and Krejci (2012) for typological discussions of causative morphology with different transitivity classes.

under causativization, and I posit that for the Lubukusu case, this is what underlies the difference in the symmetry patterns of ingestive verbs.

Previous work on ingestive verbs has argued that ingestives are reflexive, bieventive causatives in their simple form (Jackendoff 1990, Amberber 2002, Krejci 2012). The treatment of these verbs as bieventive arises from the fact that there are two subevents of eating: the manipulation of food and the potential digestion of food, indicated by several diagnostics which I outline below for Lubukusu. The reflexivity arises from the fact that the agent who manipulates the food causes him or herself to engage in the event of digestion. Krejci (2012) represents these facts in an event template in the style of Rappaport Hovav & Levin (1998), provided in (111).

(111) [[ACT_(manipulate food)(x)] CAUSE [BECOME_(potentially digest)(x,y)]]

(Krejci 2012:80,(96))

In this template, there is an action of manipulating food which causes that food to become potentially digested. The prospective nature of the digestion is crucial due to the truth conditions of eating: it is possible that the person vomited or spit out the food and did not in fact digest it. The reflexivity is indicated by the fact that the same participant, namely *x*, is both the manipulator of the food and the digester.

The (lexically) caused variant of *eat* in English, i.e. *feed*, has the same event structure as *eat* in (111), but with an additional participant, as in (112), where there is the additional argument *z*.

(112) [[ACT_(manipulate food)(x)] CAUSE [BECOME_(potentially digest)(z,y)]]

(Krejci 2012:80,(96))

In (112), the event structure is the same as that of *eat* in (111), but the reflexivity is undone, so to speak; the participant who manipulates the food and the participant who potentially digests it are distinct. This analysis argues for the same event structure analysis for both *eat*

and *feed* in English, treating *feed* differently from *make eat*, which would have the distinct event structure in (113), where the entire meaning of *eat* is caused by some external causing event.

(113) [z CAUSE [[ACT_(man.food)(x)] CAUSE [BECOME_(pot.digest)(x,y)]]]

In this case, instead of delinking the causer from the ingester by introducing a new participant, the event structure adds an external CAUSE to the entire event structure.

I adopt this analysis for caused ingestives in Lubukusu, translating the details into the formalism used in Chapters 3 and 4. I propose the denotation of *khu-lia* ‘to eat’ in (114), paralleling the event structural analysis proposed by Krejci in (111).

(114) a. $[[khu\textit{lia}]] := \lambda x \lambda y \lambda s \lambda v \lambda e [ag'(v, y) \wedge th'(s, x) \wedge s \subset e \wedge v \subset e \wedge$
manipulating.food'(v) \wedge fin'(s, e) \diamond digesting'(s) \wedge ag'(s, y)]
 b. $\langle \underline{DP}_{ag} DP_{th} \rangle$

Like Krejci’s analysis, there are two subevents: a causing event *v* and a resulting event *s* (as is the case with other causative verbs, cf. Chapter 4). The causing event *v* is one of manipulating food, while the resulting event is that of prospective digestion. As is the case in English, the truth conditions of *khu-lia* ‘to eat’ in Lubukusu do not entail that the food was eaten. For example, in (115), it is felicitous that the food is eaten, but then thrown up (and, hence, not digested).

(115) *Wafula a-∅-l-ile biyakhulia, mala k-a-rusi-a.*
 Wafula 1S-PST-eat-PERF food but 1S-PST-vomit-FV
 ‘Wafula ate the food, but he threw it up.’

I notate the prospective digestion with the symbol \diamond . The prospective digestion has three participants: the digester *y*, the element being eaten *x*, and the event *s* which they are linked to. For clarity, consider the sentence in (116a) with the verb *khu-lia* ‘to eat’.

- (116) a. *Wafula a-∅-li-le kumuchele.*
 Wafula 1S-PST-eat-PERF rice
 ‘Wafula ate the rice.’
- b. $\exists s \exists v \exists e [ag'(v, wafula') \wedge th'(s, rice') \wedge s \subset e \wedge v \subset e \wedge manipulating.food'(v) \wedge$
 $fin'(s, e) \wedge \diamond digesting'(s)$
 $\wedge ag'(s, wafula')]$

This sentence means that Wafula acted to manipulate the food, and as a result of this action, he potentially digests the food.

This analysis makes various predictions about the nature of eating events in Lubukusu, paralleling those for the analysis of ingestives in English (and other languages) in Krejci (2012). The analysis of *khu-lia* ‘eat’ as a bieventive causative verb predicts that it should be possible to separate the causing event from the result state. One diagnostic for this is the scope of “again” modification, which should have a narrow reading that only has scope over the second subevent of the causal chain. Consider a context where someone is eating rice, and the rice is cursed so that it regenerates after you have eaten it.

- (117) *Wekesa alile kumuchele lundi.*
 Wekesa ate rice again
 ‘Wekesa ate the rice again.’
- (118) *Wekesa alile kumuchele kwachona lundi.*
 Wekesa ate rice same again
 ‘Wekesa ate the same rice again.’

Crucially, the data in (117) is available where someone else ate the rice the first time; it is conceivable in this magic rice situation that the first person instructs the second to “eat the rice again.” Another possible interpretation is where *lundi* ‘again’ takes scope over the entire event, in which case the sentence in (117) is interpreted as Wekesa eating the rice the first time as well as subsequent times. The ambiguity in scope supports the analysis of *khu-lia* ‘to eat’ as having a bieventive causal structure. Consider another event such as *khu-chekha* ‘to laugh’.

- (119) *Wekesa a-∅-chekhel-e lundi.*
 Wekesa 1S-PST-laugh-PERF again
 ‘Wekesa laughed again.’

In this example, there is only one interpretation: Wekesa laughed earlier and then laughed again. *khu-chekha* ‘to laugh’ is an event which has only one event, unlike *khu-lia* ‘to eat’, which has two.

Another diagnostic for probing causation was proposed by Chierchia (2004), who argues that *da sé* ‘by itself’ in Italian is licensed when cause is in the meaning of the verb (see also Koontz-Garboden 2009 and Krejci 2012). In Lubukusu, the phrase *omwene* ‘by oneself’ has the same properties as *da sé* in Italian, suggested by the inability of *omwene* to appear with *laugh*. For clarity, there is a separate word for ‘alone’, *yeng’ene*, which is not the intended sense of ‘by himself’ here.

- (120) *Wekesa alile omwene.*
 Wekesa ate by.himself
 ‘Wekesa ate by himself.’
- (121) **Wekesa achekhele omwene.*
 Wekesa laughed by.himself
 ‘Wekesa laughed by himself.’
- (122) *Wekesa achekhele yeng’ene.*
 Wekesa laughed alone
 ‘Wekesa laughed alone.’

This is evidence that *omwene* is the appropriate modifier for ‘by oneself’.

Having outlined the meaning of *khu-lia* ‘to eat’, let us consider the causative *khu-l-isy-a*, which means ‘to feed’ (and not, crucially, ‘make-eat’). I argue that these have a lexicalized meaning of that in (123), which has the same meaning as *khu-lia* ‘to eat’ in (114), with the addition of one participant.

- (123) a. $[[khumisya]] := \lambda y \lambda x \lambda z \lambda s \lambda v \lambda e [ag'(v, z) \wedge th'(s, x) \wedge \wedge s \subset e \wedge v \subset e \wedge manipulating.food'(v) \wedge fin'(s, e) \wedge \diamond digesting'(s) \wedge ag'(s, y)]$

- b. $\langle \underline{DP}_{ag_v} DP_{ag_s} DP_{th} \rangle$

In (123), the denotation is the same as (114) above, with addition of a new participant z which is the argument that is linked to the causing subevent v .²⁹ Syntactically, there is an additional DP object (the “demoted” subject of the verb). There are three participants linked to the meaning of the verb, and crucially, the agent of the event of manipulating food is not the same as the participant that prospectively digests it. This is exactly the reading of the caused variant of the verb *khu-lia* ‘to eat’ in (124).

- (124) a. *Wafula a-∅-lis-isy-e omw-ana ku-mu-chele.*
 Wafula 1S-PST-eat-CAUS-PERF 1-child 3-3-rice
 ‘Wafula fed the child rice.’
- b. $\exists s \exists v \exists e [ag'(v, wafula') \wedge th'(s, rice') \wedge s \subset e \wedge v \subset e \wedge$
manipulating.food'(v) \wedge fin'(s, e) \wedge \diamond digesting'(s) \wedge
ag'(s, child')]

In the example in (124), the reading is that Wafula is feeding the rice to the child, such as by taking the rice by hand and putting in the child’s mouth.

Turning to causation of other verbs, I assume a classic causation analysis of the morpheme *-esy* in Lubukusu, modifying the analysis of *-ish* in Kinyarwanda in Chapter 4 due to the fact that the causative and instrumental applicative are not syncretic in Lubukusu. Consider the semantics of the causative morpheme in (125a), which parallels the definition of *-ish* in Kinyarwanda in Chapter 4 in that it takes an individual and predicate as arguments. However, unlike the morpheme in Kinyarwanda, the causal subevent introduced by the causative morpheme must be the initial subevent, indicated here with the relation *init'*, which states that the first argument is the initial subevent of the second subevent (cf. the relation *fin'* proposed in Chapter 4.)³⁰

²⁹It is in fact not clear if the additional argument in the caused ingestive case is an object or a subject. In a parallel fashion to causation on other verbs in Chicheŵa, I assume that the new argument is a subject.

³⁰As is the case with the morpheme *-ish* in Kinyarwanda, the denotation here predicts (correctly) that the causative morpheme *-esy* in Lubukusu has a direct causative meaning.

- (125) a. $\llbracket -esy \rrbracket := \lambda P \lambda x_1 \dots \lambda x_n \lambda z \lambda e_1 \dots \lambda e_m [P(x_1 \dots x_n, e_1 \dots e_m) \wedge \exists e' [e' \subset e_m \wedge ag'(e', z) \wedge init'(e', e)]]$
 b. $\langle \dots \rangle \Rightarrow \langle \underline{DP}_{ag} \dots \rangle$

Here, when the causative morpheme licenses a new causative subevent which precedes the subevents denoted by the verb. Furthermore, I assume that the causer subject adds a new agent subject to the PAS of the verb to which it attaches.³¹ In order to compare the effect of morphological causativization on a non-ingestive verb with the ingestive case above, let us assume the denotation in (126) for the verb *khu-funa* ‘to break’ with the PAS in (127).

- (126) $\llbracket khu-funa \rrbracket := \lambda x \lambda y \lambda s \lambda v \lambda e [ag'(v, y) \wedge th'(s, x) \wedge v \subset e \wedge s \subset e \wedge breaking'(v) \wedge broken'(s) \wedge fin'(s, e)]$
 (127) $\langle \underline{DP}_{ag} DP_{th} \rangle$

Composing the meaning of the verb *khu-funa* ‘to break’ with the causative morpheme yields the denotation in (128a) with the corresponding PAS in (128b).

- (128) a. $\lambda x \lambda y \lambda z \lambda s \lambda v \lambda e [ag'(v, y) \wedge th'(s, x) \wedge v \subset e \wedge s \subset e \wedge breaking'(v) \wedge broken'(s) \wedge fin'(s, e) \wedge \exists e' [e' \subset e_m \wedge ag'(e', z) \wedge init'(e', e)]]$
 b. $\langle \underline{DP}_{ag_{e'}} DP_{ag_v} DP_{th} \rangle$

Consider a sentence where the verb *khu-funa* ‘to break’ is marked with the causative, such as in (129).

- (129) a. *Wafula a-kha-fun-isy-a bi-kombe omw-ana.*
 Wafula 1S-TNS-break-CAUS-FV 8-cup 1-child
 ‘Wafula is causing the child to break the cups.’
 b. $\exists s \exists v \exists e [ag'(v, child') \wedge th'(s, cups') \wedge v \subset e \wedge s \subset e \wedge breaking'(v) \wedge broken'(s) \wedge fin'(s, e) \wedge \exists e' [e' \subset e_m \wedge ag'(e', wafula') \wedge init'(e', e)]]$

³¹In the denotation of *-esy* in Lubukusu, the argument *z* follows the arguments of the verb, since it is this argument which will be mapped to subject.

Here, the meaning is that there is a causing event that precedes the subevents denoted by the verb *khu-funa* ‘to break’, and furthermore, there is a new causer subject of the PAS. Note that this denotation differs from that of *-ish* in Chapter 4 in that the participant that is linked to *e'* in (125a) is always the last individual to be picked up. On the theory outlined in Chapter 4, this means that this argument will always be the initial causer, as desired in the cause of morphological causatives in Lubukusu, where there is no syncretism and no lambda reordering.

Comparing the causation of the two verbs, it is clear that there is a difference between *khu-l-isy-a* ‘to feed’ and *khu-fun-isy-a* ‘to cause to break’ in the nature of the arguments. In the former, there is an agent, an experiencer, and a theme; in the latter, there is a causer, a demoted agent, and a theme. Crucially, there are no additional components of the meaning of the event in (123), while the causative of *khu-funa* ‘to break’ involves the addition of a new causer. I speculate that the difference in symmetry facts between the transitive verb *khu-funa* ‘to break’ and the ingestive verb *khu-lia* ‘to eat’ follows from the distinct nature of causation of the two verbs. With standard transitives, a new causer argument is added, demoting the agent. With ingestive verbs, the two objects are both direct object arguments of the underlying verb itself. While more work is needed to verify the extent to which verbs from different classes show divergent symmetry behavior in Lubukusu, the data from ingestive verbs suggest that the way in which an object is derived may affect if this object is treated as a core verb in the language.

The intuition behind this analysis, then, is that caused ingestive verbs are lexically ditransitive, which contrasts with other morphologically caused verbs, which are derived ditransitives. This analysis relies on the assumption that in general lexically ditransitive verbs are symmetrical. Evidence for comes from the verb *khu-wa* ‘to give’, which is symmetrical with respect to word order in (130), the passive diagnostic in (131), and with object marking in (132).³²

³²The verbal root is deleted in the passive in (131).

- (130) a. *Wafula a-∅-w-a Wekesa si-tabu.*
 Wafula 1S-PST-give-FV Wekesa 7-book
 ‘Wafula gave Wekesa the book.’
- b. *Wafula a-∅-w-a si-tabu Wekesa.*
 Wafula 1S-PST-give-FV 7-book Wekesa
 ‘Wafula gave the book to Wekesa.’
- (131) a. *Si-tabu sy-a-∅-ebw-a Wekesa (ne Wafula).*
 7-book 7S-PST-give-PASS-FV Wekesa by Wafula
 ‘The book was given to Wekesa by Wafula.’
- b. *Wekesa a-a-∅-ebw-a si-tabu (ne Wafula).*
 Wekesa 1S-PST-give-PASS-FV 7-book by Wafula
 ‘Wekesa was given a book by Wafula.’
- (132) a. *Wekesa a-∅-si-w-a Wafula.*
 Wekesa 1S-st-7O-give-FV Wafula
 ‘Wekesa gave it to Wafula.’
- b. *Wekesa a-∅-mu-w-a si-tabu.*
 Wekesa 1S-PST-1O-give-FV
 ‘Wekesa gave the book to him.’

These data indicate that the lexically ditransitive verb *khu-wa* ‘to give’ is symmetrical with respect to word order, passivization, object marking diagnostics, which parallels the symmetry of the caused ingestive verbs. This supports the analysis of caused ingestives as lexicalized ditransitive verbs, as they pattern the same in object symmetry as other lexically ditransitive verbs in language. While I do not have an explanation for why lexical ditransitives should matter for symmetry, on the analysis of ingestives I have proposed here, any analysis of this fact will extend directly to ingestives.

5 Conclusion

In this chapter, I have shown that there is no universal correlation between object symmetry properties and thematic type of the applicative, contra the main assumption in the litera-

ture on the syntax of applicatives. The view that semantics does not universally correlate with structure is more compatible with the variation that is found across the Bantu languages: there is no universal tendency across languages to have symmetry or asymmetry with specific thematic role types and there is no single point of variation that determines the behavior thematic object types. Furthermore, I presented suggestive evidence that there is a relationship between object symmetry and the semantics of specific verb types, relating to how the arguments are brought out (i.e. by the verb or by the causative morpheme).

Chapter 6: Conclusion

What emerges from this dissertation is the complex nature of a seemingly straightforward valency-increasing morpheme, captured in the following quote from Bresnan and Moshi (1990): “the familiar dative object construction of English can be likened to that of the game of chess to checkers” (Bresnan & Moshi 1990:148). In this dissertation, I have focused on an area that has received little attention in previous work: the interplay between applicative morphology and verb meaning.

Chapter 3 proposed a new analysis of applicative morphology where an applied variant of a verb is paradigmatically constrained to have a monotonically stronger set of truth conditions pertaining to an internal argument than the non-applied variant. Specifically, I proposed the Applicativization Output Condition in (1).

- (1) **Applicativization Output Condition:** In alternations between applied and non-applied forms of a verb, the applied variant has at least one internal argument, and the truth conditions associated with that internal argument by the predicate projected by the applied verb are a strict superset of those associated with it by the predicate projected by the non-applied variant.

The AOC restricts the kinds of paradigms that are possible between applied and non-applied variants of a given verb, and verb classes differ in how they satisfy the constraint. In addition to capturing the traditionally-discussed use of applicative as adding a new object argument, the AOC also permits other uses of the applicative where the applied variant modifies a thematic role of an argument of the verb as well as cases where the applied variant gives syntactic license to a participant present semantically in the non-applied variant. I outlined a typology of these uses in Kinyarwanda by focusing on the combination of locative applicatives with verbs of directed motion. These different uses of the applicative also vary in the degree of productivity, with certain uses being lexicalized with certain applied/non-applied, while other uses are productive.

Chapter 4 presented an analysis of the syncretic morpheme *-ish* in Kinyarwanda, which has been described as having uses as both an instrumental applicative and a morphological causative. I propose that the two uses are outgrowths of the same operation of adding an additional causal link in the causal chain described by the predicate. The position of the new causal link introduced by *-ish* is flexible, but constraints of particular verbs on the ordering of causal subevents restricts where the new subevent may appear, thus capturing the fact that certain verbs favor or rule out causative or instrumental readings.

Perhaps the most fascinating puzzle with respect to applicative morphology is surprising amount of the cross-linguistic variation. While almost every Bantu language has some kind of applicative morpheme, there is considerable inter-language variation in the possible semantic contributions of the morpheme as well as the syntactic properties of the applied object (when present). This latter question has been a widely discussed topic in Bantu linguistics, which much of the focus on deriving symmetry patterns from universal correlations between thematic role and syntactic facts of the applicative. In Chapter 5 I argued that there is no such correlation between thematic role and symmetry, and I proposed that a variety factors — such as the animacy of the NP and information structure — conspire to capture the symmetry properties in a given language with a given applicative sentence. Finally, I provided a case study with caused ingestive verbs in Lubukusu which suggests that verb class also plays a role in determining symmetry.

However, there are a number of unanswered questions here that have been left for future work. First, Chapter 3 discusses the verb *gu-tera* ‘to throw’ which has a goal object in the non-applied variant and a recipient object in the applied variant. Future work can investigate the use of benefactive applicatives with verbs which denote goals and recipients in a parallel fashion to the discussion of locative applicatives and motion verbs provided in Chapter 3.

Another question for future work is the application of the AOC in other languages. While the AOC predicts that an applied variant always encodes more information than the

corresponding non-applied variant, how the AOC is satisfied may differ across languages. One place for fruitful work is fitting the AOC with the pattern discussed in Marten (2003) where the applied variant has a stronger pragmatic contribution than the non-applied variant, as in (2c), repeated from Chapter 1.

- (2) a. *Juma a-li-va-a kanzu*
 Juma 1S-PST-wear-FV kanzu
 ‘Juma was wearing a Kanzu.’
- b. *Juma a-li-val-i-a nguo rasmi.*
 Juma 1S-PST-wear-APPL-FV clothes official
 ‘Juma was dressed up in official/formal clothes.’
- c. #*Juma a-li-val-i-a kanzu.*
 Juma 1S-PST-wear-APPL-FV kanzu
 Intended: ‘Juma was wearing a Kanzu.’ (Swahili, Marten 2003,9,(14))

The use of the applicative in (2) parallels the uses discussed in Chapter 3, though Kinyarwanda — to my knowledge — only implements the AOC at the level of the lexical entailments of the predicate. Marten’s analysis of Swahili for data like that in (2) and the analysis proposed here for Kinyarwanda are similar in many ways, and future work can address the possible unity in the variation across languages in how applied variants indicate stronger semantic and pragmatic information than non-applied variants.

Finally, Chapter 5 makes the claim that object symmetry should be investigated on a language-by-language basis, addressing how animacy, thematic role, verb meaning, and information structure all converge in a given language to determine whether the thematic object in a particular sentence is able to appear in various positions generally reserved for objects. My hope is that this dissertation will provide a framework for fruitful future work on these topics.

References

- Ackerman, F. & Moore, J. (2001). *Proto-properties and grammatical encoding: A correspondence theory of argument selection*. Stanford: CSLI Publications.
- Adams, N. (2010). *The Zulu ditransitive verb phrase*. PhD Dissertation, University of Chicago.
- Aikhenvald, A. (2000). Transitivity in Tariana. In Dixon, R. M. W. & Aikhenvald, A. (eds.), *Changing valency: Case studies in transitivity*, Cambridge: Cambridge University Press. 312–331.
- Alexiadou, A., Anagnostopoulou, E. & Schäfer, F. (2006). The properties of anti-causatives crosslinguistically. In Frascarelli, M. (ed.), *Phases of interpretation*, Berlin: Mouton de Gruyter. 187–211.
- Alsina, A. (1992). On the argument structure of causatives. *Linguistic Inquiry* **23**. 517–555.
- Alsina, A. & Mchombo, S. (1990). The syntax of applicatives in Chicheŵa: Problems for a theta-theoretic asymmetry. *Natural Language and Linguistic Theory* **8**. 493–506.
- Alsina, A. & Mchombo, S. (1993). Object asymmetries and the Chicheŵa applicative construction. In Mchombo, S. (ed.), *Theoretical aspects of Bantu grammar*, Stanford: CSLI Publications. 17–45.
- Amberber, M. (2002). Quirky alternations of transitivity: The case of ingestive predicates. In Amberber, M. & Collins, P. (eds.), *Language universals and variation*, Westport, CT: Praeger. 1–19.
- Aranovich, R. (2009). Animacy effects and locative marking in Shona applicatives. In Butt, M. & King, T. (eds.), *Proceedings of the LFG09 conference*, Stanford: CSLI Publications. 65–84.

- Asher, N. & Sablayrolles, P. (1995). A typology of discourse semantics for motion verbs and spatial PPs in French. *Journal of Semantics* **12**. 163–209.
- Ashton, E., Mulira, E., Ndawula, E. & Tucker, A. (1954). *A Luganda grammar*. Longmans, Green and Co.
- Baker, M. (1988). Theta theory and the syntax of applicatives in Chicheŵa. *Natural Language and Linguistic Theory* **6**. 353–389.
- Baker, M., Safir, K. & Sikuku, J. (2012). Sources of (a)symmetry in Bantu double object constructions. In Arnett, N. & Bennett, R. (eds.), *Proceedings of the 30th west coast conference on formal linguistics*, Somerville, MA: Cascadilla Proceedings Project. 54–64.
- Bassa Vanrell, M. (2013). Preposition typology with manner of motion verbs in spanish. Master's thesis, University of Texas at Austin.
- Bastin, Y. (1986). Les suffixes causatifs dans les langue bantoues. *Africana Linguistica* **10**. 56–145.
- Batibo, H. (1985). *Le kesukuma (langue bantu de Tanzania): phonologie, morphologie*. Paris: Centre de Recherches, d'Échanges et de Documentation Universitaire, Kenya.
- Bax, A. & Diercks, M. (2012). Information structure constraints on object marking in Manyika. *Southern African Linguistics and Applied Language Studies* **30**. 185–202.
- Beavers, J. (2010). The structure of lexical meaning: Why semantics really matters. *Language* **86**. 821–864.
- Beavers, J. (2011a). An aspectual analysis of ditransitive verbs of caused possession in English. *Journal of Semantics* **28**. 1–54.
- Beavers, J. (2011b). On affectedness. *Natural Language and Linguistic Theory* **29**. 335–370.

- Beavers, J. & Francez, I. (2012). Several problems for predicate decompositions. In Anti, Z., Chang, C. B., Hong, J., Houser, M., Sandy, C., Toosarvandani, M. & Yao, Y. (eds.), *Proceedings of Berkeley linguistics society 32*, Berkeley: University of California at Berkeley. 37–48.
- Beavers, J. & Koontz-Garboden, A. (2013). Manner and result in verbal meaning. *Linguistic Inquiry* **43**.
- Beavers, J., Levin, B. & Tham, S. W. (2010). The typology of motion expressions revisited. *Journal of Linguistics* **46**. 331–377.
- Bittner, M. (1999). Concealed causatives. *Natural Language Semantics* **7**. 1–78.
- Bond, O. (2009). The locative applicative in Eleme. *Transactions of the Philological Society* **107**. 1–30.
- Bostoen, K. & Mundeke, L. (2011). The causative/applicative syncretism in Mbuun (Bantu B87, DRC): Semantic split or phonemic merger? *Journal of African Languages and Linguistics* **32**. 179–218.
- Bresnan, J. (1994). Locative inversion and the architecture of universal grammar. *Language* **70**. 72–131.
- Bresnan, J., Asudeh, A., Toivonen, I. & Wechsler, S. (2016). *Lexical functional syntax, second edition*. Wiley Blackwell.
- Bresnan, J., Cueni, A., Tatiana & Baayen, R. H. (2007). Predicting the dative alternation. In Bouma, G., Kraemer, I. & Zwarts, J. (eds.), *Cognitive foundations of interpretation*, Amsterdam: Royal Netherlands Academy of Science. 69–94.
- Bresnan, J. & Kanerva, J. (1989). Locative inversion in Chicheŵa: A case study of factorization in grammar. *Linguistic Inquiry* **20**. 1–50.

- Bresnan, J. & Mchombo, S. (1987). Topic, pronoun, and agreement in Chichewa. *Language* **63**. 741–782.
- Bresnan, J. & Moshi, L. (1990). Object asymmetries in comparative Bantu syntax. *Linguistic Inquiry* **21**. 147–185.
- Buell, L. (2006). *Issues in zulu verbal morphosyntax*. PhD Dissertation, UCLA.
- Byarushengo, E., Duranti, A. & Hyman, L. (1977). *Haya grammatical structure*. University of Southern California Press.
- Cann, R. & Mabugu, P. (2007). Constructional polysemy: The applicative construction in chiShona. *Metalinguistica* **19**. 221–245.
- Carstens, V. (2001). Multiple agreement and case deletion: Against ϕ -incompleteness. *Syntax* **4**. 147–163.
- Carstens, V. & Diercks, M. (2013). Agreeing how? Implications for theories of agreement and locality. *Linguistic Inquiry* **44**. 179–237.
- Chierchia, G. (2004). A semantics of unaccusatives and its syntactic consequences. In Alexiadou, A., Anagnostopoulou, E. & Everaert, M. (eds.), *The unaccusativity puzzle: Explorations of the syntax-lexicon interface*, Oxford: Oxford University Press. 288–331.
- Chomsky, N. (1995). *The minimalist program*. Cambridge, MA: MIT Press.
- Chomsky, N. (2000). Minimalist enquiries: The framework. In Martin, R., Michaels, D. & Uriagereka, J. (eds.), *Step by step: Essays on minimalist syntax in honor of Howard Lasnik*, Cambridge, MA: MIT Press. 89–115.
- Chomsky, N. (2001). Derivation by phase. In Kenstowicz, M. (ed.), *Ken hale: A life in language*, Cambridge, MA: MIT Press. 1–52.

- Comrie, B. (1985). Causative verb formation and other verb-deriving morphology. In Shopen, T. (ed.), *Language typology and linguistic description III*, Cambridge: Cambridge University Press. 309–348.
- Comrie, B. (1989). *Language universals and linguistic typology*. Chicago: Chicago University Press.
- Cooper, R. (1976). Lexical and non-lexical causatives in Bantu. In Shibatani, M. (ed.), *Syntax and semantics vol. 6*, New York: Academic Press. 312–24.
- Creissels, D. (2004). Non-canonical applicatives and focalization in Tswana. Paper presented at the symposium ‘Syntax of the World’s Languages’, Leipzig.
- Creissels, D. (2006). Encoding the distinction between location and destination: A typological study. In Hickmann, M. & Robert, S. (eds.), *Space in languages: Linguistic systems and cognitive categories*, Amsterdam: John Benjamins. 19–28.
- Croft, W. (1991). *Syntactic categories and grammatical relations: The cognitive organization of information*. Chicago: University of Chicago Press.
- Croft, W. (1998). Event structure in argument linking. In Butt, M. & Geuder, W. (eds.), *The projection of arguments: Lexical and syntactic constraints*, Stanford: CSLI Publications. 21–63.
- Davy, J. & Nurse, D. (1982). Synchronic versions of Dahl’s Law: The multiple applications of a phonological dissimilation rule. *Journal of African Languages and Linguistics* 157–195.
- de Blois, K. (1970). The augment in Bantu languages. *Africana Linguistica* 4. 85–165.
- Diercks, M. (2010). *Agreement with subjects in Lubukusu*. Ph.D. dissertation, Georgetown University.

- Diercks, M. (2011). Incorporating location in argument structure: The Lubukusu locative clitic. In Bokamba, E., Shosted, R. & Ayalew, B. (eds.), *Selected proceedings of the 40th annual conference on african linguistics: African languages and linguistics today*, Somerville, MA: Cascadilla Proceedings Project. 65–79.
- Diercks, M. (2012). Parameterizing Case: Evidence from Bantu. *Syntax* **15**. 253–286.
- Diercks, M. (2013). Indirect agree in Lubukusu complementizer agreement. *Natural Language and Linguistic Theory* **31**. 357–407.
- Diercks, M. & Sikuku, J. (2011). The alternative agreement affect in Lubukusu. Unpublished ms., Pomona College and Moi University.
- Diercks, M. & Sikuku, J. (2013). Object clitics in a Bantu language: Deriving pronominal incorporation in Lubukusu. Unpublished ms., Pomona College and Moi University.
- Dixon, R. & Aikhenvald, A. (1997). A typology of argument-determined constructions. In Bybee, J., Haiman, J. & Thompson, S. (eds.), *Essays on language function and language type: Dedicated to T. Givón*, Amsterdam: John Benjamins. 71–113.
- Dixon, R. M. W. (1977). *A grammar of Yidj*. Cambridge: Cambridge University Press.
- Dixon, R. M. W. (2000). A typology of causatives: Form, syntax, and meaning. In Dixon, R. M. W. & Aikhenvald, A. (eds.), *Changing valency: Case studies in transitivity*, Cambridge: Cambridge University Press. 30–83.
- Donohue, M. (2001). Coding choices in argument structure: Austronesian applicatives in texts. *Studies in Language* **25**. 217–254.
- Dowty, D. (1979). *Word meaning and montague grammar*. Dordrecht: Kluwer.
- Dowty, D. (1989). On the semantic content of the notion ‘thematic role’. In Chierchia, G., Partee, B. H. & Turner, R. (eds.), *Properties, types, and meaning*, Dordrecht: Kluwer. 69–130.

- Dowty, D. (1991a). Thematic proto-roles and argument selection. *Language* **67**. 547–619.
- Dowty, D. (1991b). Towards a minimalist theory of syntactic structure. In Sijtsma, W. & van Horck, A. (eds.), *Discontinuous constituency*, Berlin: De Gruyter. 11–62.
- Dryer, M. (1983). Indirect objects in Kinyarwanda revisited. In Perlmutter, D. (ed.), *Studies in relational grammar vol. 1*, Chicago: Chicago University Press. 129–140.
- Engel, R. & Allhisser de Engel, M. (1987). *Diccionario Zoque de Francisco Leon*. México: Instituto Lingüístico de Verano.
- Fillmore, C. J. (1968). The case for case. In Bach, E. & Harms, R. T. (eds.), *Universals in linguistic theory*, New York: Holt. 1–90.
- Fillmore, C. J. (1970). The grammar of *Hitting* and *Breaking*. In Jacobs, R. & Rosenbaum, P. S. (eds.), *Readings in English transformational grammar*, Waltham: Ginn. 120–133.
- Fodor, J. (1970). Three reasons for not deriving ‘kill’ from ‘cause to die’. *Linguistic Inquiry* **1**. 429–38.
- Folli, R. & Harley, H. (2004). Consuming results in Italian and English: Flavors of *v*. In Slabakova, R. & Kempchinsky, P. (eds.), *Aspectual inquiries*, Dordrecht: Kluwer. 95–120.
- Folli, R. & Harley, H. (2007). Causation, obligation, and argument structure: On the nature of little *v*. *Linguistic Inquiry* **38**. 197–238.
- Folli, R. & Ramchand, G. (2005). Prepositions and results in Italian and English: an analysis from event decomposition. In Verkuyl, H. J., de Swart, H. & van Hout, A. (eds.), *Perspectives on aspect*, Netherlands: Springer. 81–105.
- Gary, J. & Keenan, E. (1977). On collapsing grammatical relations in universal grammar. In Cole, P. & Sadock, J. (eds.), *Syntax and semantics: Grammatical relations*, New York: Academic Press. 83–120.

- Gazdar, G., Klein, E., Pullum, G. & Sag, I. (1985). *Generalized phrase structure grammar*. Harvard University Press.
- Ginet, C. (1990). *On action*. Cambridge: Cambridge University Press.
- Givón, T. (1983). Topic continuity in discourse: An introduction. In Givón, T. (ed.), *Topic continuity in discourse: A quantitative cross-linguistic study*, Amsterdam: John Benjamins. 1–41.
- Goldberg, A. E. (1995). *Constructions: A construction grammar approach to argument structure*. Chicago: University of Chicago Press.
- Goldberg, A. E. (2002). Surface generalizations: An alternative to alternations. *Cognitive Linguistics* **13**. 327–356.
- Goldberg, A. E. (2014). The information structure of the ditransitive informs its scope properties and long-distance dependency constraints. In Bourns, S. K. & Myers, L. L. (eds.), *Perspectives on linguistic structure and context: Studies in honor of Knud Lambrecht*, Amsterdam: John Benjamins. 3–16.
- Green, G. (1974). *Semantic and syntactic regularity*. Bloomington, IN: Indiana University Press.
- Guerssel, M. (1986). *On Berber verbs of change: A study of transitivity alternations*. Cambridge, MA: MIT Press, Lexicon Project, Center for Cognitive Science.
- Hale, K. & Keyser, S. (1993). On argument structure and the lexical expression of syntactic relations. In Hale, K. & Keyser, S. (eds.), *The view from building 20: Essays in linguistics in honor of sylvain bromberger*, Cambridge, MA: MIT Press. 53–109.
- Hale, K. & Keyser, S. (1997). The limits of argument structure. In Mendikoetxea, A. & Uribe-Etxebarria, M. (eds.), *Theoretical issues at the morphology-syntax interface*, Bilbao: Universida de País Vasco, Euskal Herriko Univertsitatca. 203–230.

- Hale, K. & Keyser, S. (1998). The basic elements of argument structure. In *Mit working papers in linguistics* 32. Cambridge, MA: MIT Press. 73–118.
- Hale, K. & Keyser, S. (2002). *Prolegomenon to a theory of argument structure*. Cambridge, MA: MIT Press.
- Harford, C. (1993). The applicative in ChiShona and Lexical Mapping Theory. In Mchombo, S. (ed.), *Theoretical aspects of bantu grammar*, Stanford: CSLI Publications. 93–111.
- Harley, H. (1995). Sase bizarre: The structure of Japanese causatives. In Koskinen, P. (ed.), *Proceedings of the canadian linguistic society meeting*.
- Harley, H. (2003). Possession in the double object construction. In Pica, P. & Rooryck, J. (eds.), *Linguistic variation yearbook 2*, Amsterdam: John Benjamins. 31–70.
- Harley, H. (2008). On the causative construction. In *Handbook of japanese linguistics*, Oxford: Oxford University Press. 20–53.
- Hemmings, C. (2013). Causatives and applicatives: The case for polysemy in Javanese. *SOAS Working Papers in Linguistics* 16. 167–194.
- Henderson, B. (2006). *The syntax and typology of Bantu relative clauses*. PhD Dissertation, University of Illinois Urbana Champaign.
- Hopper, P. J. (1985). Causes and affects. In *Chicago Linguistic Society* 21. 67–88.
- Hyman, L. & Duranti, A. (1982). The object relation in Bantu. In Hopper, P. & Thompson, S. (eds.), *Syntax and semantics 15: Studies in transitivity*, New York: Academic Press. 217–239.
- Ichihashi-Nakayama, K. (1996). The “applicative” in Hualapai: its functions and meanings. *Cognitive Linguistics* 7. 227–239.

- Jackendoff, R. (1990). *Semantic structures*. Cambridge, MA: MIT Press.
- Jeong, Y. (2007). *Applicatives: Structure and interpretation from a minimalist perspective*. Amsterdam: John Benjamins.
- Jerro, K. (2013a). *Argument structure and the typology of causatives in Kinyarwanda: Explaining the causative-instrumental syncretism*. MA Report: University of Texas at Austin.
- Jerro, K. (2013b). When quantifiers agree in person: Anomalous agreement in Bantu. In *Studies in the linguistic: Illinois working papers*. 21–36.
- Jerro, K. (2015). Revisiting object symmetry in Bantu. In Ruth Kramer, O. T. B., Elizabeth Zsiga (ed.), *The selected proceedings of the 44th Annual Conference on African Linguistics*, Somerville, MA: Cascadilla Proceedings Project. 130–145.
- Jerro, K. (In Press). Locative applicatives and the semantics of verb class. In *The selected proceedings of the 46th Annual Conference on African Linguistics*.
- Jerro, K. & Wechsler, S. (2015). Quantifiers and person morphology: The case study of Bantu. In *Agreement from a diachronic perspective*. Berlin: Mouton de Gruyter. 147–164.
- Jones, M. (1996). *Foundations of French syntax*. Cambridge: Cambridge University Press.
- Katamba, F. (2003). Bantu nominal morphology. In *The Bantu languages*, New York: Routledge. 103–120.
- Kay, P. (2005). Argument structure constructions and the argument-adjunct distinction. In Fried, M. & Boas, H. C. (eds.), *Grammatical constructions: Back to the roots*, Amsterdam: John Benjamins. 71–98.
- Kimenyi, A. (1979). *Studies in Kinyarwanda and Bantu phonology*. Carbondale: Linguistic Research Inc.

- Kimenyi, A. (1980). *A relational grammar of Kinyarwanda*. University of California Press.
- Kisseberth, C. & Abasheikh, M. I. (1977). The object relationship in Chi-mwi:ni, a Bantu language. In Cole, P. & Sadock, J. (eds.), *Syntax and semantics: Grammatical relations*, New York: Academic Press. 179–218.
- Kittilä, S. (2005). Recipient-prominence vs. beneficiary-prominence. *Linguistic Typology* **9**. 269–297.
- Kittilä, S. & Zúñiga, F. (2010). *Benefactives and malefactives: Typological perspectives and case studies*. Amsterdam: John Benjamins.
- Koenig, J.-P., Mauner, G., Bienvenue, G. & Conklin, K. (2008). What with? the anatomy of a (proto)-role. *Journal of Semantics* **25**. 175–220.
- Koontz-Garboden, A. (2007). *States, changes of state, and the monotonicity hypothesis*. PhD Dissertation, Stanford University.
- Koontz-Garboden, A. (2009). Anticausativization. *Natural Language and Linguistic Theory* **27**. 77–138.
- Koontz-Garboden, A. (2012). The monotonicity hypothesis. In McNally, L. & Demonte, V. (eds.), *Telicity change and state: A cross-categorial view of event structure*, Oxford: Oxford University Press. 139–161.
- Koopman, H. (2000). Prepositions, postpositions, circumpositions and particles: The structure of Dutch PPs. In Koopman, H. (ed.), *The syntax of specifiers and heads*, London: Routledge. 204–260.
- Kratzer, A. (1996). Severing the external argument from its verb. In *Phrase structure and the lexicon*, Netherlands: Springer. 109–137.
- Krejci, B. (2012). Causativization as antireflexivization: A study of middle and ingestive verbs. M.A. Report: University of Texas at Austin.

- Kuroda, S.-Y. (1965). Causative forms in Japanese. *Foundations of Language* 30–50.
- Kuroda, S.-Y. (1993). Lexical and productive causatives in Japanese: an examination of the theory of paradigmatic structure. *Journal of Japanese Linguistics* 15. 1–83.
- Ladusaw, W. & Dowty, D. (1988). Toward a non-grammatical account of thematic roles. In Wilkins, W. (ed.), *Thematic relations*, San Diego: Academic Press. 62–72.
- Lakoff, G. (1965). *On the nature of syntactic irregularity*. Ph.D. dissertation, Indiana University Bloomington.
- Levin, B. (1993). *English verb classes and alternations: A preliminary investigation*. Chicago: University of Chicago Press.
- Levin, B. & Rappaport Hovav, M. (1995). *Unaccusativity: At the syntax-lexical semantics interface*. Cambridge, MA: MIT Press.
- Levin, B. & Rappaport Hovav, M. (2005). *Argument realization*. Cambridge: Cambridge University Press.
- Lewis, D. (1973). Causation. *Journal of Philosophy* 70. 556–567.
- Lewis, M. P., Simons, G. F. & Fennig, C. D. (2016). *Ethnologue: Languages of the world, nineteenth edition*. Dallas, TX: SIL International. <http://www.ethnologue.com>.
- Li, Y. (1990). X⁰-binding and verb incorporation. *Linguistic Inquiry* 21. 399–426.
- Machobane, M. (1989). *Some restrictions on the Sesotho transitivity morphemes*. Ph.D. dissertation, McGill University.
- Maho, J. F. (1999). *A comparative study of Bantu noun classes*. Göteborg: Acta Universitatis Gothoburgensis.
- Manning, C., Sag, I. & Iida, M. (1999). The lexical integrity principle of Japanese causatives. *Studies in contemporary phrase structure grammar* 39–79.

- Marantz, A. (1984). *On the nature of grammatical relations*. Cambridge, MA: MIT Press.
- Marantz, A. (1993). Implications of asymmetries in double object constructions. In Mchombo, S. (ed.), *Theoretical aspects of Bantu grammar*, Stanford: CSLI Publications. 113–148.
- Marantz, A. (1997). No escape from syntax: Don't try morphological analysis in the privacy of your own lexicon. In *U. Penn working papers in linguistics*. vol. 4, 201–225.
- Marlo, M. (2014). Exceptional patterns of object marking in Bantu. *Studies in African Linguistics* **43**. 85–123.
- Marlo, M. (2015). On the number of object markers in Bantu languages. *Journal of African Languages and Linguistics* **36**. 1–65.
- Marten, L. (2003). The dynamics of Bantu applied verbs: An analysis at the syntax-pragmatics interface. In Lévikaza, K. K. (ed.), *Acts du 3e congrès mondial de linguistique africaine lomé 2000*, Köln: Köppe. 207–221.
- Marten, L. & Kempson, R. (2002). Pronouns, agreement, and the dynamic construction of verb phrase interpretation: A dynamic syntax approach to Bantu clause structure. *Linguistic Analysis* **32**. 471–504.
- Marten, L., Kula, N. & Thwhala, N. (2007). Parameters of morphosyntactic variation in Bantu. *Transactions of the Philological Society* **105**. 253–338.
- Masica, C. (1976). *Defining a linguistic area: South Asia*. Chicago: University of Chicago Press.
- McCawley, J. (1978). Conversational implicature and the lexicon. In Cole, P. (ed.), *Syntax and semantics vol. 9*, New York: Academic Press. 245–59.
- McGinnis, M. (2001). Variation in the phase structure of applicatives. *Linguistic Variation Yearbook* **1**. 105–146.

- McGinnis, M. (2004). UTAH at merge: Evidence from multiple applicatives. In *Mit working papers in linguistics 49: Perspectives on phases*, Cambridge, MA: MIT Press. 183–200.
- McGinnis, M. (2008). Applicatives. *Language and Linguistic Compass* **2**. 1225–1245.
- McGinnis, M. & Gerds, D. (2003). A phase-theoretic analysis of Kinyarwanda multiple applicatives. In *Proceedings of the 2003 canadian linguistic association annual conference department of linguistics*, Université du Québec à Montréal. 154–165.
- Mchombo, S. (2004). *The syntax of Chichewa*. Cambridge: Cambridge University Press.
- Meeussen, A. E. (1967). Bantu grammatical reconstructions. *Africana Linguistica* **3**. 79–121.
- Miyagawa, S. (1984). Blocking and Japanese causatives. *Lingua* **64**. 177–207.
- Mohanan, K. (1983). Move NP or lexical rules?: Evidence from Malayalam causativization. In Levin, L., Rappaport Hovav, M. & Zaenen, A. (eds.), *Papers in Lexical-Functional Grammar*, Bloomington, IN: Indiana University Linguistics Club. 47–111.
- Morolong, M. & Hyman, L. (1972). Animacy, objects, and clitics in Sesotho. *Studies in African Linguistics* **8**. 199–218.
- Mutonyi, N. (2000). *Aspects of Bukusu morphology and phonology*. PhD Dissertation, Ohio State University.
- Myers, A. (1974). Phonology of Kikuyu. Unpublished ms., MIT.
- Myers, S. (2003). F0 timing in Kinyarwanda. *Phonetica* **60**. 71–97.
- Nedjalkov, V. & Silnitsky, G. (1973). The typology of morphological and lexical causatives. In Kiefer, F. (ed.), *Trends in soviet linguistics*, Boston: D. Reidel. 1–32.
- Ngonyani, D. (1996). *The morphosyntax of applicatives*. PhD Dissertation, UCLA.

- Ngonyani, D. & Githinji, P. (2006). The asymmetric nature of Bantu applicative constructions. *Lingua* **116**. 31–63.
- Nikitina, T. (2008). Pragmatic factors and variation in the expression of spatial goals: The case of *in* vs. *into*. In *Syntax and semantics of spatial P*. Amsterdam: John Benjamins.
- Næss, Å. (2007). *Prototypical transitivity*. Amsterdam: John Benjamins.
- Næss, Å. (2009). How transitive are EAT and DRINK verbs? In Newman, J. (ed.), *The linguistics of eating and drinking*, Amsterdam: John Benjamins. 27–43.
- Nunberg, G., Sag, I. A. & Wasow, T. (1994). Idioms. *Language* **76**. 833–858.
- Nurse, D. (2008). *Tense and aspect in Bantu*. Oxford: Oxford University Press.
- Overdulse, C. (1975). *Apprendre la langue rwanda*. The Hague: Mouton.
- Parsons, T. (1990). *Events in the semantics of English*. Cambridge, MA: MIT Press.
- Perlmutter, D. & Postal, P. (1983). Some proposed laws of basic clause structure. In Perlmutter, D. (ed.), *Studies in relational grammar, vol 1.*, Chicago: Chicago University Press. 81–128.
- Pesetsky, D. (1995). *Zero syntax: Experiences and cascades*. Cambridge, MA: MIT Press.
- Peterson, D. (2007). *Applicative constructions*. Oxford: Oxford University Press.
- Pinker, S. (1989). *Learnability and cognition*. Cambridge, MA: MIT Press.
- Pollard, C. (1984). *Generalized phrase structure grammars*. Ph.D. dissertation, Stanford University.
- Primus, B. (1999). *Case and thematic roles: Ergative, accusative and active*. Tübingen: Max Niewmeyer Verlag.
- Pulleyblank, D. (1983). *Tone in lexical phonology*. Ph.D. dissertation, MIT.

- Pylkkänen, L. (2000). What applicative heads apply to. In *University of Pennsylvania working papers in linguistics 7.1*.
- Pylkkänen, L. (2008). *Introducing arguments*. Cambridge: MIT Press.
- Ramchand, G. (2008). *Verb meaning and the lexicon: A first phase syntax*. Cambridge: Cambridge University Press.
- Rappaport Hovav, M. & Levin, B. (1998). Building verb meanings. In Butt, M. & Geuder, W. (eds.), *The projection of arguments: Lexical and compositional factors*, Stanford: CSLI Publications. 97–134.
- Rappaport Hovav, M. & Levin, B. (2008). The English dative alternation: A case for verb sensitivity. *Journal of Linguistics* **44**. 129–167.
- Rappaport Hovav, M. & Levin, B. (2010). Reflections on manner/result complementarity. In Doron, E., Rappaport Hovav, M. & Sichel, I. (eds.), *Syntax, lexical semantics, and event structure*, Oxford: Oxford University Press. 21–38.
- Reidel, K. (2007). Object marking in Sambiaa. *Linguistics in the Netherlands* **24**. 199–210.
- Rissman, L. (2011). Instrumental *with* and *use*: modality and implicature. *Proceedings of SALT 21*. 532–551.
- Rooryck, J. (1996). Prepositions and minimalist case-marking. In Thráinsson, H., Epstien, S. & Peter, S. (eds.), *Studies in comparative Germanic syntax, vol. ii*, Dordrecht: Kluwer. 226–256.
- Rothstein, S. (2004). *Structuring events*. Blackwell Publishing.
- Rude, N. (1986). Topicality, transitivity, and the direct object in Nez Perce objects. *International Journal of American Linguistics* **52**. 124–153.

- Rugemalira, J. M. (1993). *Runyambo verb extension and constraints on predicate structure*. Ph.D. dissertation, University of California, Berkeley.
- Rugemalira, J. M. (2004). Locative arguments in Bantu. In *Proceedings of the 4th World Congress of African Linguistics*, Cologne: Rüdiger Köppe Verlag. 285–296.
- Schadeberg, T. (2003). Derivation. In Nurse, D. & Philippson, G. (eds.), *The Bantu languages*, New York: Routledge. 71–89.
- Schaefer, R. (1985). Motion in Tswana and its characteristic lexicalization. *Studies in African Linguistics* **16**. 57–87.
- Schlesinger, I. (1989). Instruments as agents: On the nature of semantics relations. *Journal of Linguistics* **25**. 189–210.
- Seymour, R. (2016). Kinyarwanda Dictionary. kinyarwanda.net.
- Shibatani, M. (1973). Semantics of Japanese causativization. *Foundations of Language* **9**. 327–373.
- Shibatani, M. (1976). The grammar of causative constructions: A conspectus. In Shibatani, M. (ed.), *Syntax and semantics vol. 6*, New York: Academic Press. 1–40.
- Shibatani, M. (2002). Introduction: Some basic issues in the grammar of causation. In Shibatani, M. (ed.), *The grammar of causation and interpersonal manipulation*, Amsterdam: John Benjamins. 1–22.
- Shibatani, M. & Pardeshi, P. (2002). The causative continuum. In Shibatani, M. (ed.), *The grammar of causation and interpersonal manipulation*, Amsterdam: John Benjamins. 85–126.
- Simango, S. R. (1999). Lexical and syntactic casuatives in Bantu. *Linguistic Analysis* **29**. 69–86.

- Simango, S. R. (2012). The semantics of locative clitics and locative applicatives in ciCewa. In Connell, B. & Rolle, N. (eds.), *Selected proceedings of the 41st annual conference on african linguistics: African languages and linguistics today*. Somerville, MA: Cascadilla Proceedings Project. 141–149.
- Sitoe, B. (1996). The semantics and syntax of the Tsonga verbs *kuwà* ‘fall’ and *kuntlúlá* ‘jump’, and their relatives. *South African Journal of African Languages* **16**. 144–148.
- Slobin, D. I. (1996). Two ways to travel: Verbs of motion in English and Spanish. In Shibatani, M. & Thompson, S. (eds.), *Grammatical constructions: Their form and meaning*, Oxford: Oxford University Press. 195–219.
- Smith, C. (1970). Jespersens ‘move’ and ‘change’ class and causative verbs in English. In Jazayery, M. A., Polomé, E. C. & Winter, W. (eds.), *Linguistic and literary studies in honor of Archibald Hill vol. 2*, The Hague: Mouton. 101–109.
- Son, M.-J. & Cole, P. (2008). An Event-Based Account of *-kan* Constructions in Standard Indonesian. *Language* **84**. 120–160.
- Svenonius, P. (2007). Adpositions, particles, and the arguments they introduce. In Reuland, E., Bhattacharya, T. & Spathas, G. (eds.), *Argument structure*, Amsterdam: John Benjamins. 63–103.
- Swift, K. E. (1988). *Morfología del Caquinte (arawak preandino)*. Yarinacocha: Perú: Instituto Lingüístico de Verano.
- Talmy, L. (1975). Semantics and syntax of motion. In Kimball, J. P. (ed.), *Syntax and semantics vol. 4*, New York: Academic Press. 181–238.
- Talmy, L. (1976). Semantic causative types. In Shibatani, M. (ed.), *Syntax and semantics vol. 6*, New York: Academic Press.

- Tham, S.-W., Beavers, J. & Levin, B. (2012). Directional interpretations with locative prepositions. Paper presented at “The Meaning of P” in Bochum, Germany.
- Thomas, E. (2004). On ‘syntactic’ versus ‘semantic’ telicity: Evidence from *in* and *on*. *Belgian Journal of Linguistics* **18**. 145–166.
- Tuggy, D. (1988). Náhuatl causative/applicatives in cognitive grammar. In *Topics in cognitive linguistics*, Amsterdam: John Benjamins. 587–618.
- van Riemsdijk, H. (1990). Functional prepositions. In Pinkster, H. & Genee, I. (eds.), *Unity in diversity: Papers presented to Simon C. Dik on his 60th birthday*, Dordrecht: Foris. 229–241.
- van Riemsdijk, H. & Huijbregts, R. (2008). Locations and locality. In Karimi, S., Samiiian, V. & Wilkins, W. K. (eds.), *Phrasal and clausal architecture: Syntactic derivation and interpretation. in honor of Joseph E. Edmonds*, Amsterdam: John Benjamins. 339–364.
- Van Valin, R. D. & Wilkins, D. P. (1996). The case for ‘effector’: Case roles, agents, agency revisited. In Shibatani, M. & Thompson, S. (eds.), *Grammatical constructions: Their form and meaning*, Oxford: Oxford University Press. 289–322.
- Vasquez Soto, V. (2002). Some constraints on Cora causative constructions. In Shibatani, M. (ed.), *The grammar of causation and interpersonal manipulation*, Amsterdam: John Benjamins. 197–244.
- von Heusinger, K. (2002). Specificity and definiteness in sentence and discourse structure. *Journal of Semantics* **19**. 245–274.
- Wald, B. (1998). Issues in the North/South syntactic split of East Bantu. In Maddieson, I. & Hinnebusch, T. J. (eds.), *Language history and linguistic description in Africa*, Trenton: AfricaWorld Press. 95–106.

- Wasike, A. (2007). *The left-periphery, wh-in-situ and A-bar movement in LuLubukusu and other Bantu languages*. Ph.D. dissertation, Cornell University.
- Wechsler, S. (2005). What is right and wrong about little *v*. In Vulchanova, M. & Afarli, T. A. (eds.), *Grammar and beyond — essays in honour of Lars Hellan*, Oslo: Novus Press. 179–195.
- Wechsler, S. (2015). *Word meaning and syntax: Approaches to the interface*. Oxford: Oxford University Press.
- Welmers, W. E. (1973). *African language structures*. Berkeley, Los Angeles, and London: University of California Press.
- Wunderlich, D. (1997). Cause and the structure of verbs. *Linguistic Inquiry* **28**. 27–68.
- Zeller, J. (2006). Agreement and the EPP in Kinyarwanda applicatives. In Brandt, P. & Fuß, E. (eds.), *Form, structure, and grammar*, Berlin: Akademie-Verlag. 275–295.
- Zeller, J. & Ngoboka, J. P. (2006). Kinyarwanda locative applicatives and the Minimal Link Condition. *Southern African Linguistics and Applied Language Studies* **24**. 101–124.
- Zeller, J. & Ngoboka, J. P. (2014). On parametric variation in Bantu, with particular reference to Kinyarwanda. *Transactions of the Philological Society* 1–26.
- Zlatev, J. & Yangklang, P. (2004). A third way to travel: The place of Thai in motion-event typology. In Strömquist, S. & Verhoeven, L. (eds.), *Relating events in narrative, vol 2: Typological and contextual perspectives*, Mahwah: Lawrence Erlbaum. 159–190.
- Zwicky, A. (1986). Concatenation and liberation. In Farley, A. M. (ed.), *Proceedings of the twenty-second regional meeting (general session) of the Chicago Linguistics Society*. 65–74.