



Research

Enhancements of the Kronos
Simulation Package and Database
for Geometric Design Planning,
Operations and Traffic Management
in Freeway Networks/Corridors
(Phase II)

The funding for this project was provided by Metro Traffic Management.

Technical Report Documentation Page

1. Report No. MN/RC - 95/17	2.	3. Recipient's Accession No.	
4. Title and Subtitle ENHANCEMENTS OF THE KRONOS SIMULATION PACKAGE AND DATABASE FOR GEOMETRIC DESIGN PLANNING, OPERATIONS AND TRAFFIC MANAGEMENT IN FREEWAY NETWORKS/CORRIDORS (PHASE II)		5. Report Date December 1994	
		6.	
7. Author(s) Eil Kwon, Panos Michalopoulos, Hui Xie, Sai Tong		8. Performing Organization Report No.	
9. Performing Organization Name and Address University of Minnesota 500 Pillsbury Drive SE Minneapolis, MN 55455		10. Project/Task/Work Unit No.	
		11. Contract (C) or Grant (G) No. (C) 70284 TOC #98	
12. Sponsoring Organization Name and Address Minnesota Department of Transportation 395 John Ireland Boulevard St. Paul Minnesota, 55155		13. Type of Report and Period Covered Final Report 1993-1994	
		14. Sponsoring Agency Code	
15. Supplementary Notes			
16. Abstract (Limit: 200 words) <p>This report summarizes the enhancement results of the KRONOS freeway traffic simulation package. KRONOS is a personal computer-based, dynamic freeway simulation software, which is based on the continuum flow modeling approach. Unlike other macroscopic simulation programs, KRONOS explicitly models interrupted flow behavior such as merging, diverging, and weaving.</p> <p>The resulting KRONOS version, v8.0, which operates under the MS-DOS® environment, can simulate two freeways merging/diverging with a common section for a total length up to 20 miles with eight lanes. The new multi-stage incident module can handle up to six capacity-variant stages, which allows evaluation of various management strategies. A spread-sheet formatted output file stores the simulated results of traffic parameters, such as flow, speed, and density. Separate output files also store the measures of effectiveness, such as delay and total travel time. The current version takes approximately three minutes to simulate a 20-mile section for one hour on an IBM-PC compatible with the Pentium-90 MHZ processor.</p>			
17. Document Analysis/Descriptors Traffic modeling Macroscopic simulation Freeway merging/diverging		18. Availability Statement No restrictions. Document available from: National Technical Information Services, Springfield, Virginia 22161	
19. Security Class (this report) Unclassified	20. Security Class (this page) Unclassified	21. No. of Pages 134	22. Price

1
2
3
4
5
6
7
8
9
10
11
12
13
14
15
16
17
18
19
20
21
22
23
24
25
26
27
28
29
30
31
32
33
34
35
36
37
38
39
40
41
42
43
44
45
46
47
48
49
50
51
52
53
54
55
56
57
58
59
60
61
62
63
64
65
66
67
68
69
70
71
72
73
74
75
76
77
78
79
80
81
82
83
84
85
86
87
88
89
90
91
92
93
94
95
96
97
98
99
100

**Enhancements of the KRONOS Simulation Package and
Database for Geometric Design Planning, Operations and
Traffic Management in Freeway Networks/Corridors
(Phase II)**

Final Report

Prepared by

Eil Kwon
ITS Institute, Center for Transportation Studies
University of Minnesota
Minneapolis, MN 55455

Panos Michalopoulos
Hui Xie
Sai Tong
Department of Civil Engineering
University of Minnesota
Minneapolis, MN 55455

December 1994

Published by

Minnesota Department of Transportation
Office of Research Administration
200 Ford Building Mail Stop 330
117 University Avenue
St Paul Minnesota 55155

This report represents the results of research conducted by the authors and does not necessarily represent the views or policy of the Minnesota Department of Transportation. This report does not contain a standard or specified technique.



ACKNOWLEDGMENT

This research was supported by the Minnesota Department of Transportation and the ITS Institute, Center for Transportation Studies, University of Minnesota.

The financial support of oil overcharge funds distributed through the Minnesota Department of Administration is acknowledged, but the authors assume complete responsibility for the contents herein.



EXECUTIVE SUMMARY

KRONOS is a personal computer-based, dynamic freeway simulation software, which is based on continuum flow modeling approach. Unlike other macroscopic simulation programs, KRONOS explicitly models interrupted flow behavior such as merging, diverging and weaving. The coupling effects of ramps on the main freeway are considered in determining actual amount of flows entering/exiting freeways, which makes it possible to follow the simultaneous development of queues and propagation of congestion on both the freeway and the ramps. KRONOS employs the simple continuum modeling approach with a numerical scheme specifically designed to solve time-dependent, compressible flows containing strong shocks. With this scheme, the space domain is discretized in short increment, i.e., 100 ft, and the macroscopic parameters such as speed, flow and density are calculated every 1 second for each 100 ft segment in a given freeway.

This report summarizes the final results of the current project to enhance the KRONOS program. The resulting version, V8.0, being operated under the MS-DOS environment, can handle two freeways merging/diverging with a common section with total length up to 20 miles and eight lanes wide. The input data preparation is performed interactively using pop-up menu screen with a mouse. For instance, the geometrics are entered by selecting the configuration of each segment from the available alternatives presented on the screen. The current version has a total of 26 available segment types, which can treat most of the freeways in the U.S. Further, a new incident simulation module that can handle up to six stages in terms of time-varient capacities is also added to the new version. Following definition of the geometrics of each segment, the entire freeway can be plotted for verification. The other input requirements include the arrival/departure demand pattern at the freeway boundaries and ramps in user specified time intervals (minimum 1 minute). The demand patterns are also plotted for verification and can be as complex as desired. The program allows employment of user-specified flow-density models which are entered interactively. The change to input already entered can be made at any stage during the data entry.

The simulated results of flow parameters, i.e., speed, flow and density, are stored in a spreadsheet formatted output file and the measures of effectiveness such as total travel, total travel time and delay are derived. These Measures of Effectiveness (MOE) values are summarized by zone, defined as

a section between ramps, and presented on the monitor screen. Two and three dimensional plots of density, speed and flow are also produced for showing the evolution of these basic variables in space and time. With these plots, user can visualize the propagation and dissipation of shock waves and congestion on both the freeway and ramps. The spread-sheet file can be directly imported by the Lotus 1-2-3 package for more flexible analysis of the simulation results using the Lotus functions. For a faster and easier presentation of the propagation of disturbances along the freeway as well as a quick review of its operation, the segmentized form of the freeway is presented on the screen and the density variation of each segment is plotted continuously through time with different colors according to its level.

TABLE OF CONTENTS

EXECUTIVE SUMMARY

I. INTRODUCTION

1.1 Background	1
1.2 Research objectives	2
1.3 Report organization	2

II. ENHANCEMENTS OF THE KRONOS SIMULATION PACKAGE

II .1 Introduction	3
II .2 Basic modeling and simulation procedure of KRONOS	3
II .3 Development of new traffic models for special freeway segments	
II .3.1 Modeling of special weaving segment	7
II .3.2 Modeling of merging/diverging of two freeways with a common section	16
II .4 Development of multi-stage incident module	
II .4.1 Identification of incident and traffic diversion process	27
II .4.2 Development of multi-stage incident module	30
II .5 Development of diversion treatment module at exit ramps	35
II .6 Enhancements of user interface	39
II .7 Development of a dynamic memory allocation module	40
II .8 Summary	41

III. DEVELOPMENT OF A STANDARD PROCEDURE FOR TESTING AND VALIDATION OF TRAFFIC MODELS IN KRONOS

III.1 Introduction	43
III.2 Development of a framework for standard testing procedure	43
III.3 Development of test cases for qualitative testing	47
III.4 Development of test cases for quantitative testing	49
III.5 Manual calibration procedure for flow-density relationship	55
III.6 Summary	58

IV. TESTING AND VALIDATION OF KRONOS WITH PROPOSED TESTING PROCEDURE

IV.1 Introduction	59
IV.2 Qualitative testing	59
IV.3 Quantitative testing	63
IV.4 Summary	73

V. CONCLUSION AND FURTHER RESEARCH NEEDS

75

BIBLIOGRAPHY

APPENDIX

- A. Source code for dynamic memory allocation module
- B. Alternative object-oriented programming framework for future KRONOS
- C. Test cases in KRONOS V8.0 input file format
- D. KRONOS V8.0 User manual

LIST OF FIGURES

Figure 2-1	Simulation procedure flow chart (I)	5
Figure 2-2	Simulation procedure flow chart (II)	6
Figure 2-3	Space discretization of a special weaving section	8
Figure 2-4	Geometrics for special weaving test section	13
Figure 2-5	Demand pattern for testing special weaving section	13
Figure 2-6	Density plot of first six minutes of mainline under congested condition	14
Figure 2-7	Density plot of first five minutes of auxiliary lane under congested condition	14
Figure 2-8	Freeway merging segment types	16
Figure 2-9	Freeway diverging segment types	17
Figure 2-10	Example of a freeway section merging into main freeway	18
Figure 2-11	Geometrics of two freeways merging into one freeway test section	21
Figure 2-12	Demand pattern of merging freeway test section	21
Figure 2-13	Example of a diverging freeway segment	23
Figure 2-14	Geometrics of two freeways diverging test section	26
Figure 2-15	Demand pattern of diverging freeway test section	26
Figure 2-16	Multi-stage incident process	28
Figure 2-17	An example multi-stage incident process	29
Figure 2-18	Relationship between Q_{in} and upstream segment density	32
Figure 2-19	Relationship between Q_{out} and downstream segment density	33
Figure 2-20	Case for increase in capacity	33
Figure 2-21	Cases for capacity decrease	34
Figure 2-22	Space discretization for off-ramp area	35
Figure 3-1	Geometric segment types in KRONOS	45
Figure 3-2	Framework of the test procedure	46
Figure 3-3	Geometrics of a hypothetical integrated freeway system	48
Figure 3-4	Freeway geometrics for case 1	49
Figure 3-5	Freeway geometrics of case 494W	51
Figure 3-6	Geometrics of case 35WN	53
Figure 3-7	Geometrics of case 35W62E	54
Figure 3-8	Manual procedure for flow-density curve	57
Figure 4-1	Three dimensional mainline density plot for hypothetical case 1	61
Figure 4-2	Density plot of first six minutes for test case 2	61
Figure 4-3	Geometrics of merging/diverging freeway test section	62
Figure 4-4	Demand pattern of merging/diverging freeway test section	62
Figure 4-5	Demand pattern on Nov. 14, 1989, for 35WPIPE case	64
Figure 4-6	Demand patten on Nov.20, 1989, for 35WPIPE case	64
Figure 4-7	Comparison between simulation and real data on Nov. 14, 1989	65
Figure 4-8	Comparison between simulation and real data on Nov. 20, 1989	65
Figure 4-9	Comparison between simulation and real data for detector station 186	68
Figure 4-10	Comparison between simulation and real volume data for detector station 53N	71
Figure 4-11	Comparison between simulation and real speed data for detector station 53N	71
Figure 4-12	Comparison between simulation and real data for 35W62E case	73

LIST OF TABLES

Table 4-1	Field vs Simulated results for 494W case	67
Table 4-2	Field vs Simulated results for 35WN case	70
Table 4-3	Field vs Simulated results for 35W62E case	72

I. INTRODUCTION

I.1 Background

Improving freeway operations, performing effective traffic management and evaluating design plans requires the ability to assess the effectiveness of various alternatives prior to implementation. Responding to the need for an efficient freeway traffic analysis tool, a personal computer-based freeway simulation software, called KRONOS, has been developed by the University of Minnesota. Although the prototype version had been completed and tested with the I-35W freeway data, there still existed problems to be resolved before it could be fully operational in an integrated traffic management environment. Those problems include the limitation to one-directional freeways, lack of automatic calibration of simulation parameters and testing procedures, time-consuming manual process in preparing input data files, and lack of modules that can treat special segment types, such as HOV-lanes.

The ultimate goal of this research is to enhance KRONOS as an on-line freeway traffic analysis tool that can support traffic management decisions by providing the evaluation results of various operational alternatives in real time. Phase I of this research has substantially enhanced the performance of traffic models in KRONOS including the propagation of congestion at internal boundaries with different capacities. Further, a prototype graphical freeway database management system was also developed to demonstrate the feasibility of integrating database with simulation. The current research, Phase III, continues the enhancements of KRONOS by extending the simulation module to treat two-freeways merging/diverging with a common section, multi-stage incident process and by developing a new mouse-driven, user interface with pop-up menu.

I.2 Research objectives

The specific objectives of the current research, Phase II, are as follows:

- Development of new traffic models that can treat two freeways merging/diverging with a common section and special weaving segment with two auxiliary lanes,
- Enhancement of the incident/construction module, so that it can handle time-dependent capacity variations in the incident/construction zone,
- Development of dynamic memory allocation procedure,
- Development of a standard test procedure for traffic models in KRONOS and testing,
- Development of a new mouse-driven, window-type user interface that can support new features in the simulation module.

Further, a new simulation function is developed to reflect time-variant traffic diversion at exit ramps when there exists severe congestion downstream. Using this function, the effects of various diversion strategies on the traffic performance on a given freeway can be evaluated.

I.3 Report organization

This report documents the final results from the current phase of the KRONOS enhancement effort in the following order:

Chapter II : The detailed description of the enhancements of the simulation module and user interface.

Chapter III: The new procedure for testing and manual-calibration of KRONOS.

Chapter IV: Test results of enhanced KRONOS using the test procedure developed in Chapter III.

Chapter V : Conclusions and further research needs.

II. ENHANCEMENTS OF THE KRONOS SIMULATION PACKAGE

II.1 Introduction

This chapter summarizes the enhancements made to the KRONOS simulation package in this research. The enhancements regarding the traffic simulation module includes;

- Development and incorporation of new traffic models to treat special weaving section and two-directional freeways with a common section.
- Enhancement of the incident/construction module to handle the time-variant capacity in the incident/construction zone.
- Development of a dynamic memory allocation module.
- Enhancement of exit ramp module to handle traffic diversion.

Further, a new user interface has been developed to use the mouse with pop-up menu screens. The rest of this chapter summarizes the new simulation modules and enhancements made to the user interface.

II.2 Basic modeling and simulation procedure of KRONOS

KRONOS is a macroscopic simulation program. It employs the simple continuum modeling approach which is based on the conservation equation and an equilibrium speed density (or flow-density) relationship. The model can be described by:

$$\begin{aligned} \frac{\partial k}{\partial t} + \frac{\partial q}{\partial x} &= g(x, t) \\ q &= ku = ku_e(k) \end{aligned} \quad (\text{Eq. 2-1})$$

where k , q , u , t , x , represent density, flow, speed, time, distance respectively, and g is the generation term. Further, $u_e(k)$ represents the equilibrium speed-density relationship. For implementation of the above model, KRONOS uses a finite difference scheme specifically designed to solve one-dimensional, time-dependent, compressible flows containing strong shocks. With this scheme the time and space domains are discretized in short increments, dt and dx

respectively, such that $\frac{dt}{dx} > u_f$, where u_f is the free flow speed. This condition assures that

vehicles entering dx are stored within dx during dt period. The relevant formulas are as follows:

$$\begin{aligned} k_i^{n+1} &= \frac{1}{2}(k_{i+1}^n + k_{i-1}^n) - \frac{dt}{2dx}(q_{i+1}^n - q_{i-1}^n) - \frac{dt}{2}(g_{i+1}^n + g_{i-1}^n) \\ u_i^{n+1} &= u_e(k_i^{n+1}) \\ q_i^{n+1} &= k_i^{n+1} \cdot u_i^{n+1} \end{aligned} \quad (\text{Eq. 2-2})$$

where k_i^n , u_i^n , q_i^n , g_i^n denote traffic density, speed, flow and generation at node i at the n time step ($dx = 100\text{ft}$ and $dt = 1$ second); $u_e(k_i^{n+1})$ is the equilibrium speed density relationship which is location specific.

Figures 2-1 and 2-2 illustrate the overall simulation procedure of KRONOS. After determining the initial density of each dx in a given freeway with user-specified initial flow conditions, it calculates q , k and u for every dx and dt , i.e., 100 feet and 1 second. For each time slice, new traffic demand entering/departing freeway at upstream/downstream boundaries as well as entrance/exit ramps are used as boundary conditions. The calculation of q , k and u for each dx is implemented from the upstream boundary to the downstream end dx for each freeway section, i.e., main, merging and diverging freeway sections. With estimated q , k and u for each dx , the Measure of Effectiveness, such as Total Travel Time and Delay, are calculated for each zone and stored in the output file at user-specified output time intervals. This procedure is repeated until the current time reaches the user-specified simulation period. The rest of this chapter summarizes the step-by-step algorithms for treating new segment types.

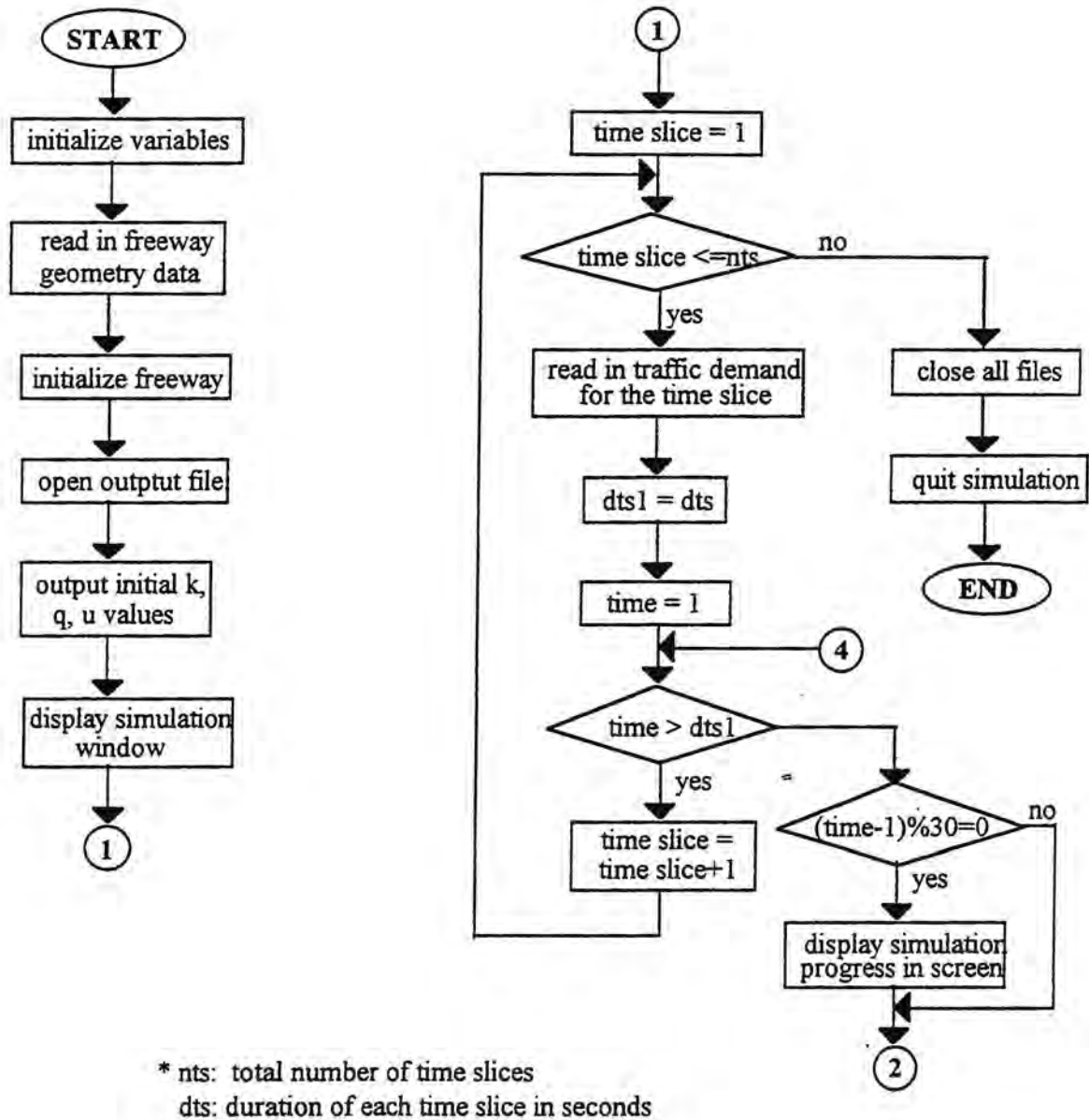

Figure 2-1 Simulation Procedure Flow Chart (I)

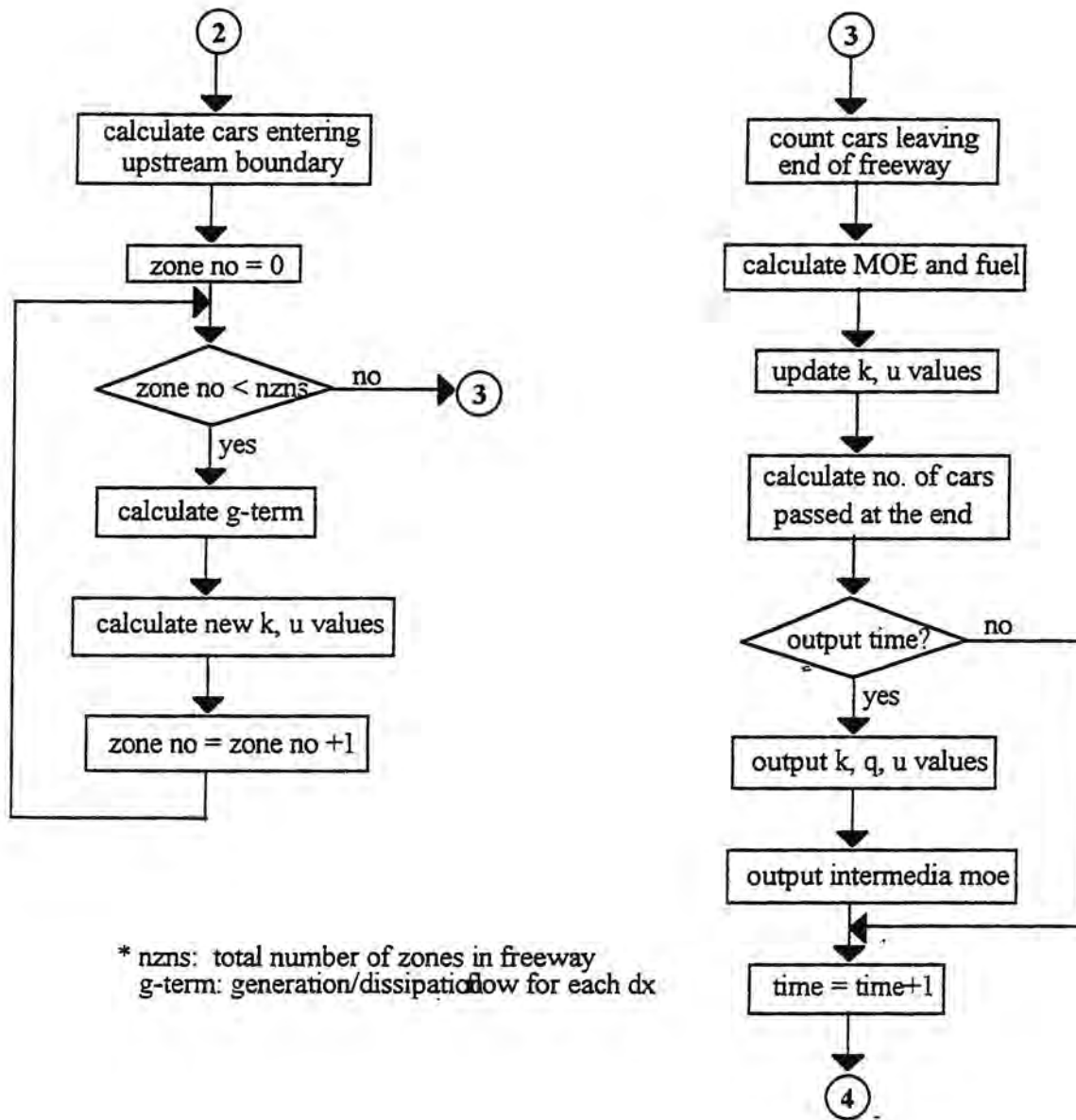

Figure 2-2 Simulation Procedure Flow Chart (II)

II.3 Development of new traffic models for special freeway segments

II.3.1 Modeling of special weaving segment

This section discusses the modeling of the special weaving section, which has two auxiliary lanes as shown in Figure 2-3. By adding one auxiliary lane to the conventional weaving segment type, the new weaving section tries to separate the weaving conflict from the main flow, thereby decreasing traffic turbulence in the mainline.

In Figure 2-3, link A and B are pipelines attached before and after the special weaving section. Link E and F constitute the on and off ramps of the special weaving section. Link C is the mainline section of the freeway, and link D is the actual weaving section. Link D consists of two auxiliary lanes: in addition to the normal auxiliary lane it also includes the deceleration lane for exiting demand and the acceleration lane for the merging demand. The nodes starting with O are the starting nodes of each link, and the nodes starting with J are the ending nodes of each link.

The modeling methodology of this special weaving section is similar to the weaving model with one auxiliary lane except the internal boundary among link A, C and D. In link A, there is only one flow. Once the flow reaches node J_a , it is divided into two flows: the flow using link D is the exiting volume, and the other flow using link C is the through volume. No matter how light the exiting demand is, there is no through demand in link D. In node M_d , merging flow and exiting flow become one flow and divide again at node N_d .

The step by step algorithm for the special weaving section is as follows:

- (1) Initialize all nodes of links A, B, C, D, E and F to the density equivalent to the user specified condition.
- (2) Determine the density k_j^{n+1} for the next time step for the each node in link A, B, C, D, E and F.

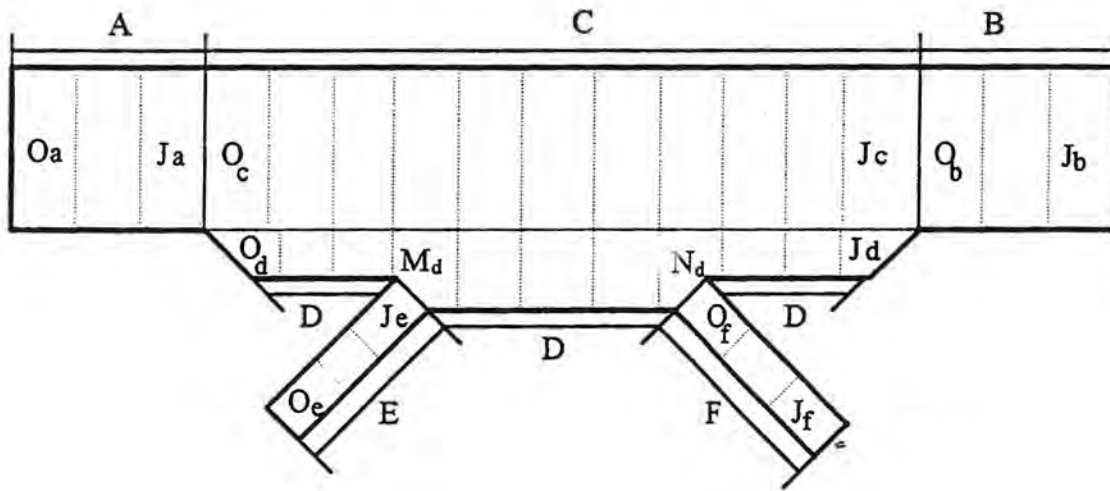

Figure 2-3 Discretization in space of a special weaving section

I. Link A, C, and D:

All nodes, except internal boundaries in these links, correspond to uninterrupted flow without generation or dissipation terms, therefore the computations are proceeded according to equations for pipeline segments.

One flow is divided into two flows at node J_a .

Step 1: determine the maximum output flow of the last node J_a of link A-- $q_{\max out J_a}$.

Step 2: only exiting volume uses link D no matter how low the exiting volume is. Except the exiting flow, all other flow must go through link C. It's easy to determine the output flow which uses the deceleration lane:

$$q_{\max out d} = q_{off}$$

$$q_{\max out c} = q_{\max out J_a} - q_{off}$$

where,

q_{off} : the exit demand of the special weaving section;

$q_{\max out J_a}$: the maximum output flow of node J_a ;

$q_{\max out d}$: the output flow of node J_a using link D;

$q_{\max out c}$: the output flow of node J_a using link C.

Step 3: determine the maximum input flow to the first node O_d of the link D and the O_c of link C-- $q_{\max in O_d}$ and $q_{\max in O_c}$.

Step 4: determine the flow which moves into node O_c and O_d : it is equal to the lesser of the input flow and output flow.

$$q_{out r} = \min(q_{\max in O_d}, q_{\max out d})$$

$$q_{out m} = \min(q_{\max in O_c}, q_{\max out c})$$

where,

$q_{out r}$: the flow from link A to link D;

$q_{out m}$: the flow from link A to link C;

$q_{\max in O_c}$: the maximum input flow to node O_c ;

$q_{\max out O_d}$: the maximum input flow to node O_d .

Step 5: the formula to calculate the density of node J_a is as follows:

$$k_{J_a}^{n+1} = \frac{1}{2}(k_{J_a-1}^n + k_{J_a}^n) + \frac{\Delta t}{\Delta x}(q_{in} - q_{out})$$

where;

$$q_{out} = q_{out_r} + q_{out_m}$$

$$q_{in} = \frac{1}{2}(q_{J_a-1}^n + q_{J_a}^n)$$

II. Link D and E:

In node M_d , the merging flow from on-ramp link E and diverging flow from link D merge. The treatment of this internal boundary is almost the same as the treatment of the internal boundary ED in weaving model case. There is a parameter α which governs the input flows from both link D and E.

III. Link D and F:

In node N_d , the entire weaving flow will be divided into two flows: one part is the exiting demand, and the other part is the on-ramp demand which merges into the mainline at the last node of link D. The treatment of this internal boundary is the same as the one used in the internal boundary DF in weaving model case.

IV. Link B, C and D:

In the last node of link D, the on-ramp demand merges into the mainline link B. Because the flow from link C will also moves into the same node with higher speed, it usually has

higher priority than the flow from link D. A step by step new algorithm without generation term is proposed below:

Step 1: determine the maximum input flow to the first node O_b in link B-- $q_{\max in O_b}$.

Step 2: determine the maximum output flow of the last node J_d of link D and the last node J_c of link C-- $q_{\max out J_d}$ and $q_{\max out J_c}$.

Step 3: the input flow to node O_b is a combination of the flow from link C and the flow from link D. The mainline input flow from link C has the priority. It is assumed that β percent of all the input space of node O_b is occupied by the $q_{\max out J_c}$ and $(1-\beta)$ percent is occupied by the merging flow from link D. The determination of β is the same as the simple on-ramp model. But if the mainline flow cannot use all this β percent space, the space left over is allocated to the merging flow.

$$q_{\max incb} = \beta \cdot q_{\max in O_b}$$

$$q_{out J_c} = \min(q_{\max out J_c}, q_{\max incb})$$

$$q_{\max indb} = q_{\max in O_b} - q_{out J_c}$$

$$q_{out J_d} = \min(q_{\max indb}, q_{\max out J_d})$$

where,

$q_{out J_c}$: the flow from link C to link B;

$q_{out J_d}$: the flow from link D to link B.

Step 4: the formula to calculate the density of node O_b is as follows:

$$k_{o_b}^{n+1} = \frac{1}{2}(k_{o_b}^n + k_{o_b+1}^n) + \frac{\Delta t}{\Delta x}(q_{in} - q_{out})$$

where,

$$q_{in} = q_{out J_c} + q_{out J_d}$$

$$q_{out} = \frac{1}{2}(q_{o_b}^n + q_{o_b+1}^n)$$

- (3) Determine the density of each dx in links E and F for the next time step using Equations 2-2 (page 4) with generation or dissipation term equal to zero.
- (4) From the density obtained in (2) and (3) above, determine the speed u_j^{n+1} and the flow q_j^{n+1} for the next time step .

- Qualitative testing

The new model is first tested using the hypothetical test cases. Figure 2-4 shows the hypothetical geometrics used for qualitative testing..

Case 1: uncongested situation. Figure 2-5 shows the demand pattern for this case. The arrival volume at the upstream boundary is kept constant at 1000 veh/hr for the 30-minute simulation period, and the volume entering through the on-ramp is 500 veh/hr for the whole simulation period. But the off ramp demand is 100 veh/hr in the first 15 minutes and increases to 200 veh/hr in the next 15 minutes. The vehicle conservation is mainly examined with this case and the estimated flow rate in the last zone was compared with the expected flow rate at the same segment. The simulation results show 0.1% error in terms of vehicle conservation with the test case.

Case 2: congested case. When there is a restriction on the exiting volume at the downstream boundary of the mainline freeway, the spillback propagates to both upstream and on-ramp. A hypothetical case is created for this testing and stored in Appendix C under the file name of swea-d.kr8, where the exit volume at the downstream boundary is restricted at 2000 vehicle/hr. The simulation results are shown in Figures 2-6 and 2-7. Figure 2-6 shows the density plot of right-most lane which is adjacent to the auxiliary lane. At time zero, this lane is uncongested. After six minutes, the higher density reaches the upstream boundary. Figure 2-7 shows the density plot of the auxiliary lane including both on-ramp and off-ramp. The first 500 ft is on-ramp, and last 500 ft

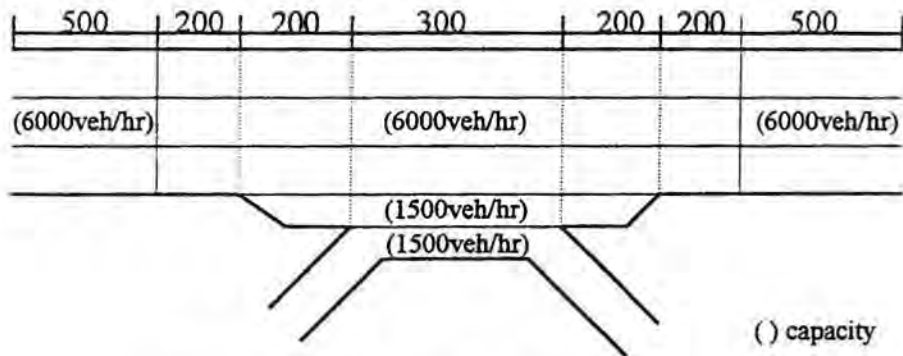

Figure 2-4 Geometrics for special weaving test section

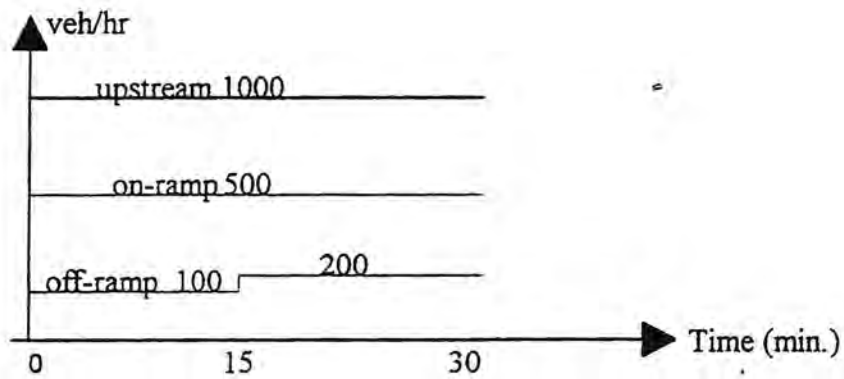

Figure 2-5 Demand pattern for testing special weaving section (uncongested case)

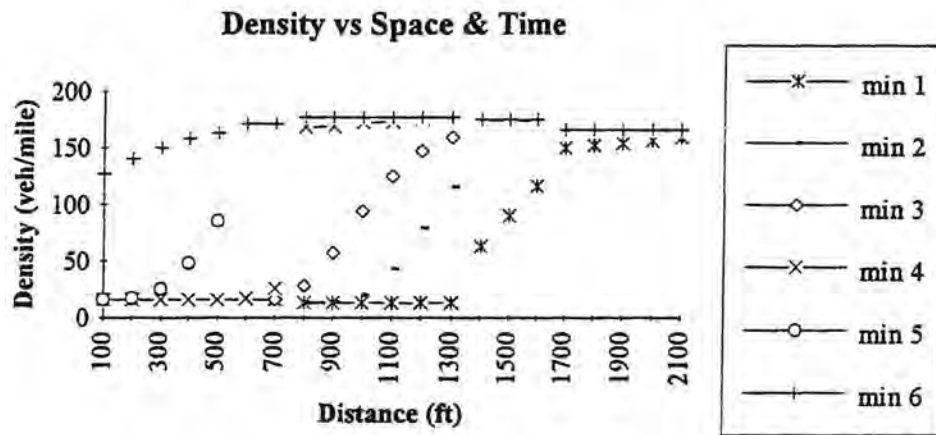

Figure 2-6 Density plot of first six minutes of mainline under congested condition

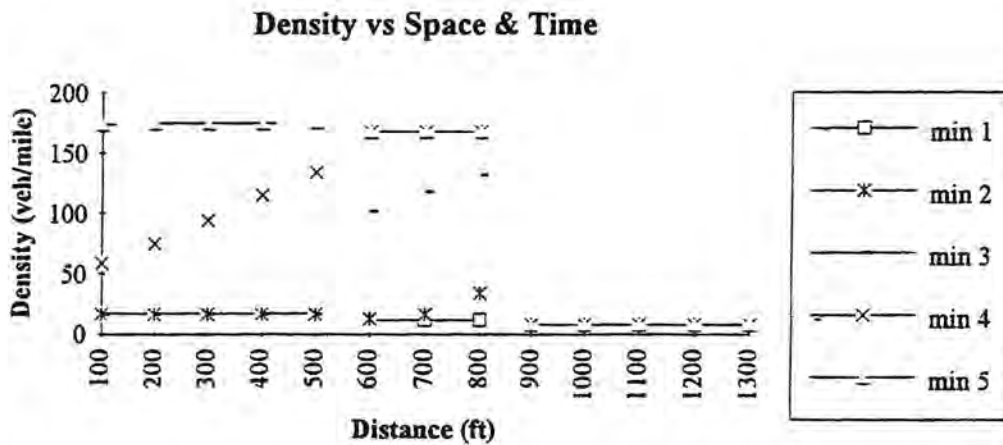

Figure 2-7 Density plot of first five minutes of auxiliary under congested condition

is off-ramp and the remaining 300 ft is auxiliary lane. The off-ramp is kept at an uncongested level but the on-ramp section becomes congested after five minutes. The propagation of congestion, represented with higher density, from downstream to upstream is clearly indicated in this Figure.

- Limitation

Because of the special treatment of the internal boundary, there are limitations on the length of this weaving segment. Link A and link B must be longer than 200 ft, and link C must be longer than 700 ft.

II.3.2 Modeling of two freeways merging/diverging

In this project, a new procedure to simulate two freeways merging/diverging with a common section is developed using existing individual merging/diverging segment models. Special attention was given to the treatment of the joint segment between main freeway and merging/diverging freeways. There are two cases involving two freeways merging/diverging with a common section in the current version of KRONOS: one-lane ramp connector and two-lane ramp connector. However, for the two-lane ramp connector there are two different situations for both merging and diverging. First case is that the number of lanes in the common section equals to the sum of the number of lanes of the two freeways upstream or downstream of the common section. The other case is that the number of lanes in the common section is one less than the sum of the number of lanes of the two freeways upstream or downstream of the common section. The second scenario involves segment types 21, 22, 23 and 24, shown in Figures 2-8 and 2-9.

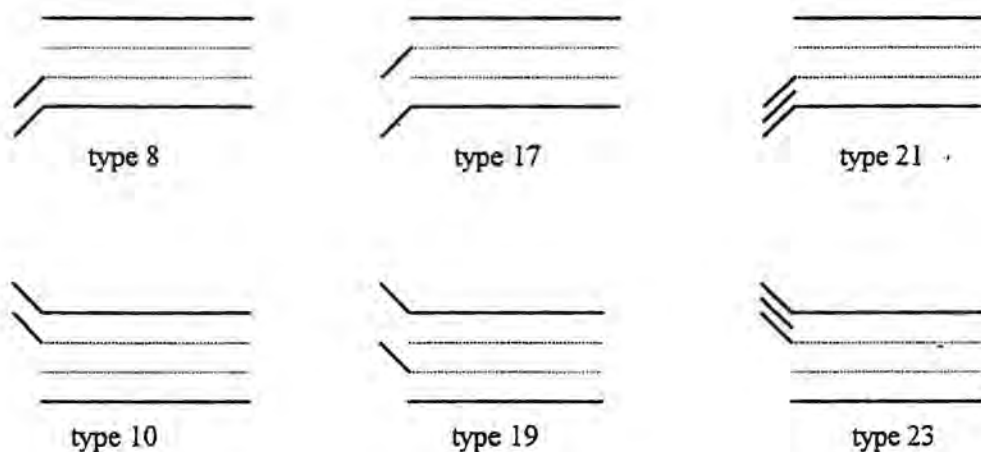

Figure 2-8 Freeway merging segment types

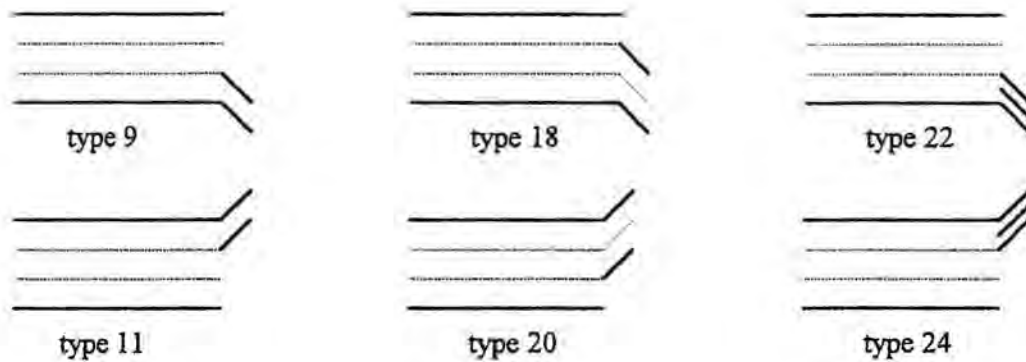

Figure 2-9 Freeway diverging segment types

II.3.2.1 Development of freeway merging module

This section discusses the modeling of two-freeways merging with a common section. Figure 2-10 shows an example of merging freeway with common section. Freeway A and B are connected together through pipeline section F of the freeway B and on-ramp section E of the freeway A. Link C is the common area between freeway A and freeway B.

The computation of simulating the merging freeway is the same as main freeway. For the merging freeway, the upstream input is also an external boundary condition specified by the users. There are two options for specifying the external boundary conditions: one is to only specify the upstream flow rate, and the second one is to specify both the upstream flow rate and the flow conditions. The second option is used to test the program with real data.

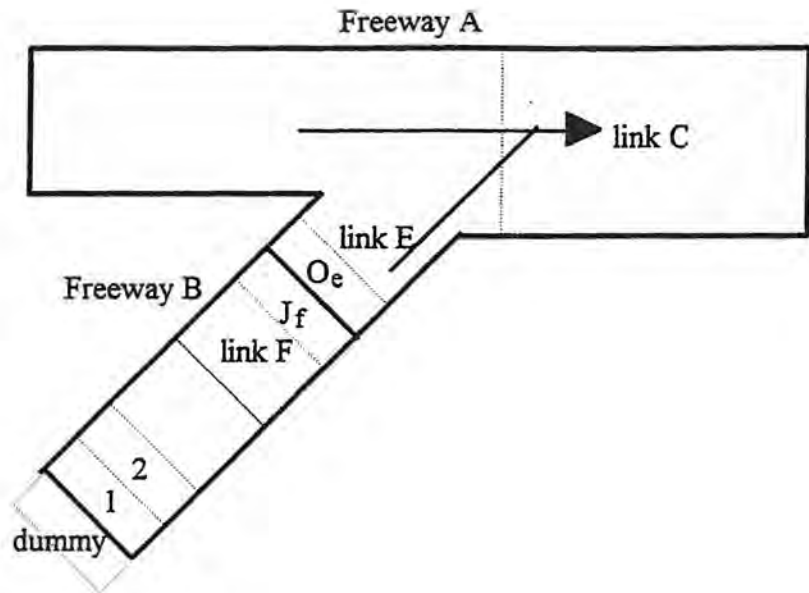

Figure 2-10 Example of a freeway section merging into main freeway

For the purposes of storing and dissipating excessive vehicles that can not get into the merging freeway in case of congestion, there is a dummy dx sitting before the starting dx of the merging freeway. A step by step algorithm for the first dx of the merging freeway is as follows:

- Option 1: when user specifies arrival flow value only:

- (1) determine the flows in the first and second dx's of the merging freeway: q_1^n and q_2^n for the time step n;
- (2) determine the available flow of the dummy dx and allowable flow of the first dx;
- (3) determine the density of the dummy dx using Euler's equation:

$$k_{dummy}^{n+1} = k_{dummy}^n + \frac{\Delta t}{\Delta x} (q_{in} - q_{out})$$

$$q_{out} = \min(q_{maxin1}, q_{maxoutd})$$

where,

q_{in} : the upstream demand given by the users;

q_{maxin1} : the maximum input flow to the first dx;

$q_{maxoutd}$: the maximum output flow of the dummy dx.

- (4) determine the density of the first dx from the following equation:

$$k_1^{n+1} = \frac{1}{2}(k_1^n + k_2^n) + \frac{\Delta t}{\Delta x} (q_{out} - \frac{1}{2}(q_1^n + q_2^n))$$

- (5) determine the flow and speed for the first dx from the flow-density relationship.

- Option 2: both flow value and condition are specified by user:

- (1) initialize the dummy dx at the upstream boundary to a density corresponding to the flow and flow condition specified by the user for the first zone at the freeway;
- (2) determine the density of the first dx of the freeway using the following equation:

$$k_1^{n+1} = \frac{1}{2}(k_{dummy}^n + k_2^n) - \frac{\Delta t}{2\Delta x} (q_2^n - q_{dummy}^n)$$

- (3) determine the flow and speed from the flow-density relationship of the first zone.

The actual connector between two freeways is node J_f and O_e . The estimation of flow across boundary FE is very important to the model performance. A step by step algorithm for the these two nodes is as follow:

- (1) determine the flows in the first and second dx's of link E: q_{oe}^n and q_{oe+1}^n for the time step n;
- (2) determine the flows in the last and second to the last dx's of link F: q_{Jf}^n and q_{Jf-1}^n for the time step n;
- (3) determine the maximum output flow of the node J_f and input flow to the node O_e
- (4) determine the density of these two nodes using following equation:

$$k_{J_f}^{n+1} = \frac{1}{2}(k_{J_f-1}^n + k_{J_f}^n) + \frac{\Delta t}{\Delta x}(\frac{1}{2}(q_{J_f-1}^n + q_{J_f}^n) - q_{out})$$

$$k_{O_e}^{n+1} = \frac{1}{2}(k_{O_e}^n + k_{O_e+1}^n) + \frac{\Delta t}{\Delta x}(q_{out} - \frac{1}{2}(q_{O_e}^n + q_{O_e+1}^n))$$

$$q_{out} = \min(q_{maxinO_e}, q_{maxoutJ_f})$$

where,

q_{maxinO_e} : the maximum input flow to the node O_e ;

$q_{maxoutJ_f}$: the maximum output flow of the node J_f .

- Qualitative testing

Hypothetical geometrics and demand pattern were created for the qualitative testing. Figures 2-11 and 2-12 show the hypothetical geometrics and the demand pattern.

For the demand pattern, the mainline upstream volume is 4000 veh/hr in the first 15 minutes and decreases to 3000 veh/hr in the next 15 minutes, and for the merging freeway the upstream and off-ramp demand are kept constant at 1000 and 500 veh/hr respectively for the entire simulation period. The simulation results indicate satisfactory model performance in terms of flow conservation.

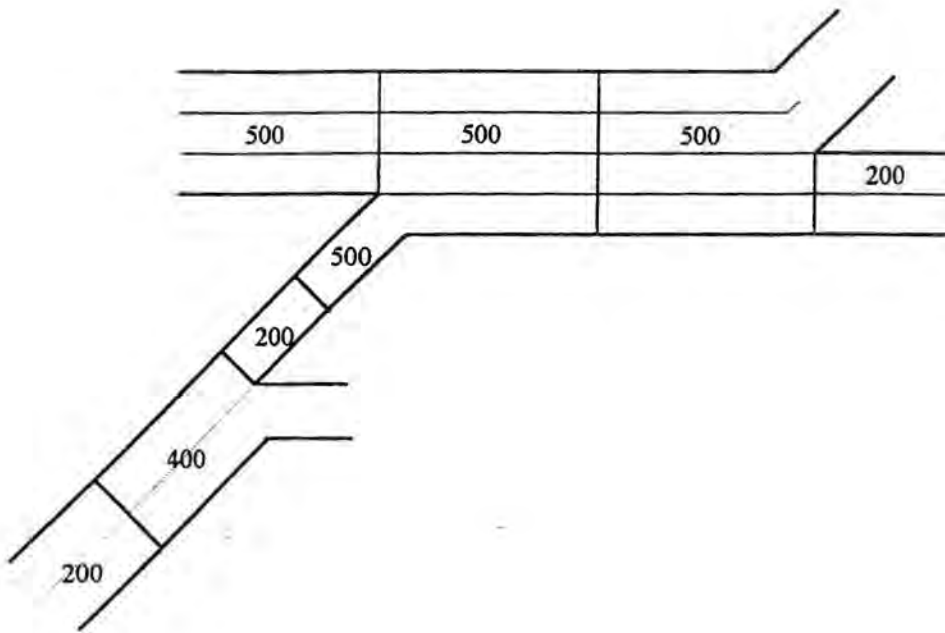

Figure 2-11 Geometrics of two freeways merging into one freeway testing section

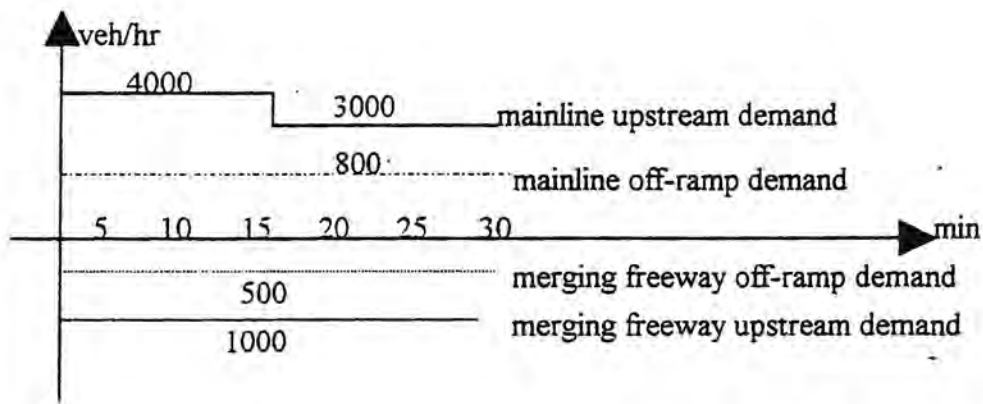

Figure 2-12 Demand pattern of merging freeway testing section

II.3.2.2 Development of freeway diverging module

This section discusses the modeling of two-freeways diverging with a common section. Figure 2-13 shows an example of diverging freeway with common section. Common section link C is split into two freeways: freeway A and freeway B. The two freeways are connected with each other through pipeline section E of freeway B and off-ramp F of freeway A.

The simulation computation of diverging freeway is the same as main freeway. For diverging freeway, the downstream output is an external boundary condition specified by the user. There are three options for specifying the external boundary conditions: the first is no downstream demand, the second is to specify only the downstream output flow rate, and the last is to specify both downstream output flow and flow conditions. The last option is used while testing the program with real data.

For the modeling purposes, there is a dummy dx sitting after the ending dx of main freeway and diverging freeway. A step by step algorithm for the last dx of the diverging freeway is presented as follows:

Option 1: no downstream boundary condition. The Lax method is used to estimate the density of the last dx.

Option 2: specify flow only:

(1) determine the flows on last two dx's of the freeway, q_{last}^n and q_{last-1}^n for the time step n.

(2) determine the density of the last dx as follows:

$$k_{last}^{n+1} = k_{last}^n + \frac{\Delta t}{\Delta x} \left(\frac{1}{2} (q_{last}^n + q_{last-1}^n) - q_{out} \right)$$

where, q_{out} : the downstream output flow specified by user.

(3) determine the flow and speed for the last dx from the flow-density relationship of the last zone of the freeway.

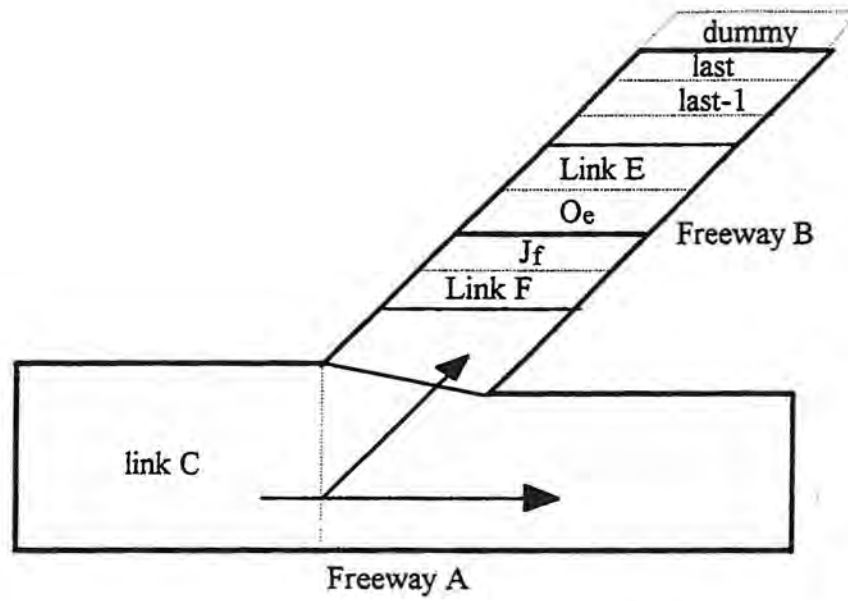

Figure 2-13 Example of a diverging freeway segment

Option 3: specify both flow and flow condition:

(1) initialize the dummy dx at the downstream boundary to the density corresponding to the flow and flow condition specified by the user for the last zone at the freeway.

(2) determine the density of the last dx of the freeway using the following equation:

$$k_{last}^{n+1} = \frac{1}{2}(k_{dummy}^n + k_{last-1}^n) - \frac{\Delta t}{2\Delta x}(q_{dummy}^n - q_{last-1}^n)$$

(3) determine the flow and speed from the flow-density relationship of the last zone.

The actual connector between these two freeways is node J_f and O_e . The estimation of flow across the boundary FE is very important to the model performance. The step by step algorithm for the these two nodes is as the follows:

(1) determine the flows in the first and second dx's of link E: q_{oe}^n and q_{oe+1}^n for the time step n;

(2) determine the flows in the last and second to the last dx's of link F: q_{jf}^n and q_{jf-1}^n for the time step n;

(3) determine the maximum output flow of the node J_f and input flow to the node O_e

(4) determine the density of these two nodes using following equation:

$$k_{j_f}^{n+1} = \frac{1}{2}(k_{j_f-1}^n + k_{j_f}^n) + \frac{\Delta t}{\Delta x}(\frac{1}{2}(q_{j_f-1}^n + q_{j_f}^n) - q_{out})$$

$$k_{o_e}^{n+1} = \frac{1}{2}(k_{o_e}^n + k_{o_e+1}^n) + \frac{\Delta t}{\Delta x}(q_{out} - \frac{1}{2}(q_{o_e}^n + q_{o_e+1}^n))$$

$$q_{out} = \min(q_{maxinO_e}, q_{maxoutJ_f})$$

where,

q_{maxinO_e} : the maximum input flow to the node O_e ;

$q_{maxoutJ_f}$: the maximum output flow of the node J_f .

- Qualitative testing

Hypothetical geometrics and demand pattern were created for testing flow conservation with the new geometric type. Figures 2-14 and 2-15 show the hypothetical geometric and the demand pattern. For the demand pattern, the mainline upstream volume is 4000 veh/hr in the first 15 minutes and decreases to 3000 veh/hr in the next 15 minutes. The diverging demand from the main freeway into the diverging freeway is kept constant at 800 veh/hr for entire 30-minute period. The simulation results indicated that flow conservation was achieved in the entire test section including the diverging segment.

II.3.2.3 Limitations

Due to the memory limitation of the DOS operating system, the current freeway merging/diverging with common section module can handle three sections of freeway including main freeway, one merging freeway and one diverging freeway. The total length of these three freeway sections cannot exceed 20 miles. Each one of these three freeway sections must be started and ended with a pipeline section due to the special treatment of the internal boundaries.

Only segment types listed in Figures 2-8 and 2-9 (pages 16 and 17) can be used as freeway merging/diverging connectors. New types of connectors will be introduced into the program in the future.

Currently the program cannot simulate a diverging freeway with downstream boundary flow restriction. Downstream flow rate and flow condition options can only be used for the case with real data.

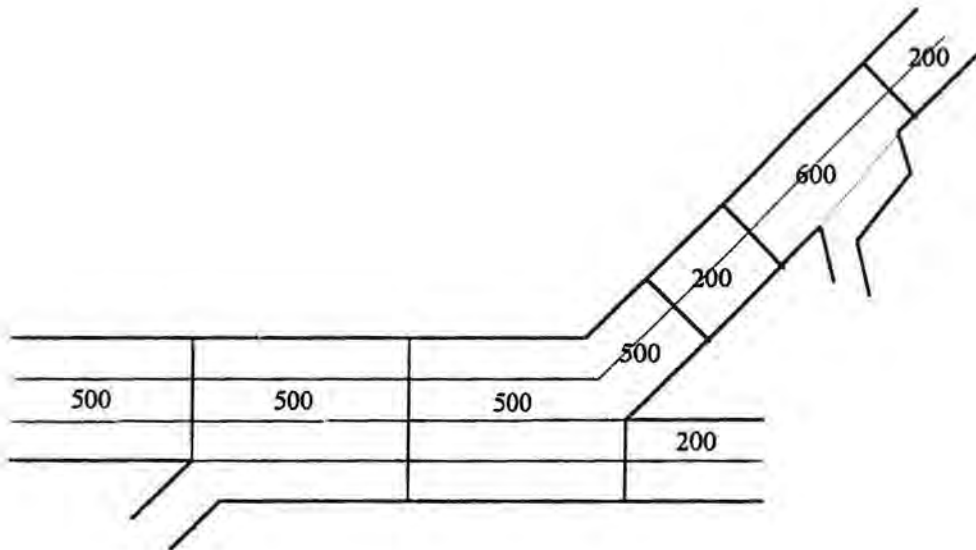

Figure 2-14 Geometrics of two freeways diverging test section

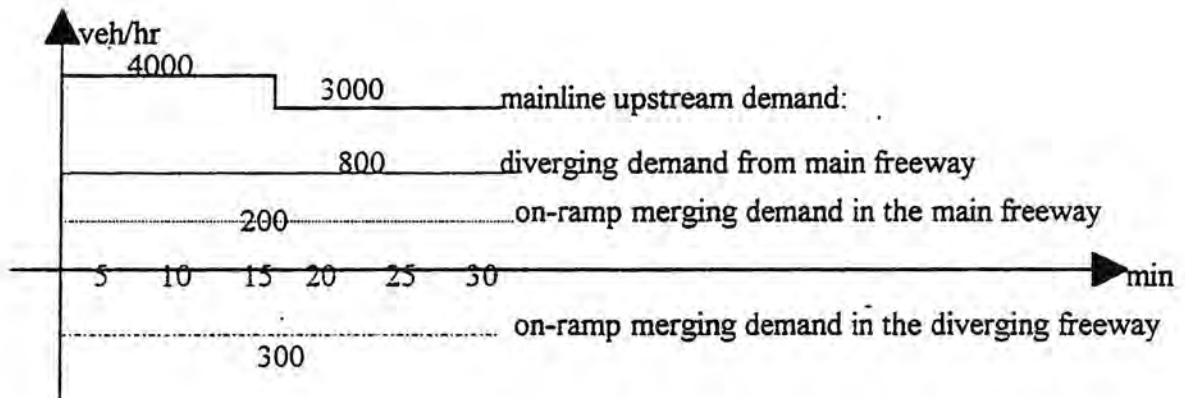

Figure 2-15 Demand pattern of diverging freeway test section

II.4 Development of multi-stage incident module

II.4.1 Identification of incident and traffic diversion process

Freeway incident process can be divided into multi-stages according to the incident management process, which can be represented as the changes in the capacity of the incident zone. There are few simulation software with the multi-stage incident simulation capability. The previous version of KRONOS, V7.0, deals with only single stage incident. Therefore, it could not evaluate the effects of different incident management strategies on the traffic performance in the mainline. This section describes the new enhanced incident module that can handle time-variant capacities in the incident zone. The new module can simulate up to six-stage incidents on the pipe-line sections.

When an incident occurs, a portion of the freeway is closed and capacity of the incident/construction area is reduced. When the through demand is greater than the reduced capacity of the incident area, congestion develops and propagates upstream resulting in spillback. Depending on the incident management strategy, the capacity of the incident area can vary through time with different stages. While the number of stages can vary depending on the management schemes, in general, the following stages can represent the incident process:

- 1) Detection/response stage
- 2) Initial management stage
- 3) Mainline clearance stage
- 4) Shoulder management stage
- 5) Capacity recovering stage

Figure 2-16 graphically illustrates each stage and Figure 2-17 shows an example capacity variation process through time.

(i) detection stage

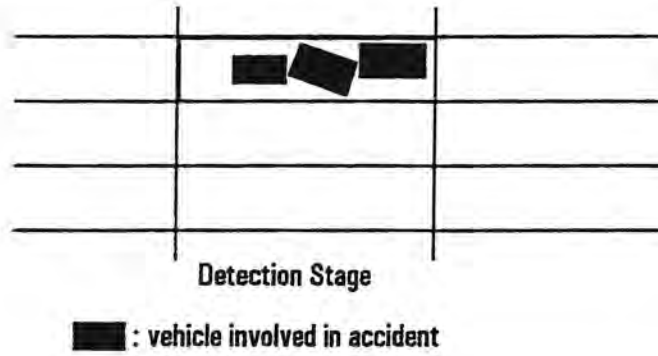

(ii) Initial management stage

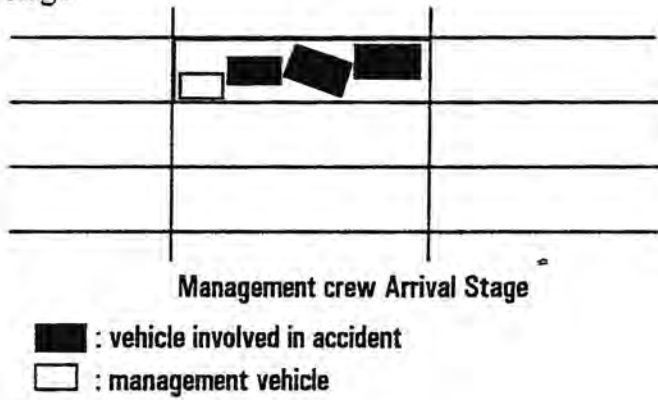

(II) mainline managing stage

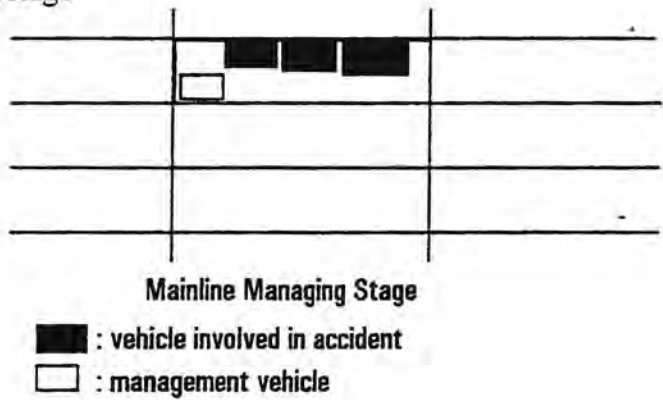

Figure 2-16. Multi-stage incident process (continued)

(iv) shoulder managing stage

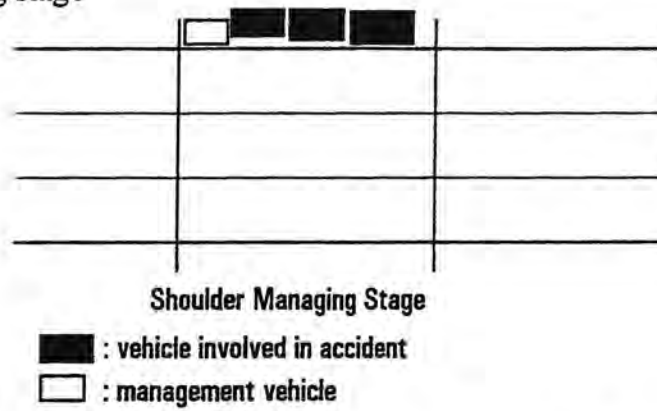

Figure 2-16 Multi-stage incident process (continued)

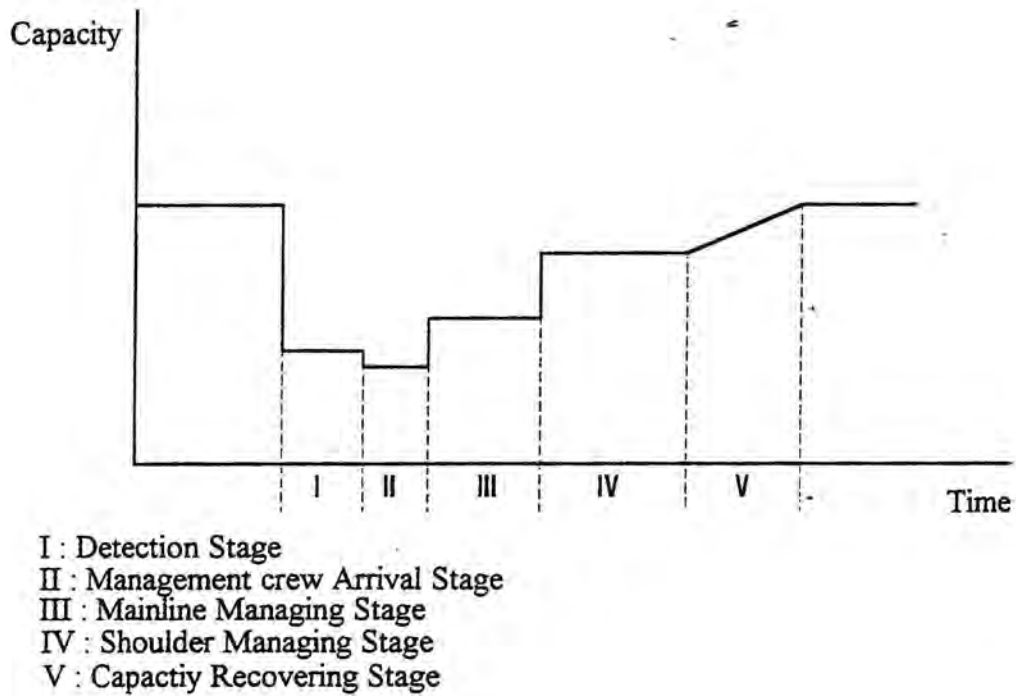

Figure 2-17 An example multi-stage incident process

II.4.2 Development of multi-stage incident module

The new model treats the incident area consisting of internal boundaries and uses a new normalization scheme to calculate the density of next time step. In this research, a modified boundary condition approach is used. The general equation used to find the density of Dx "i" at next time step "n+1" is as follow

$$k_i^{n+1} = \frac{1}{2}(k_{i+1}^n + k_{i-1}^n) - \frac{dt}{2dx}(q_{i+1}^n - q_{i-1}^n) + \frac{dt}{2}(g_{i+1}^n + g_{i-1}^n)$$

For the pipeline, the generation is zero so that the equation is simplified as

$$k_i^{n+1} = \frac{1}{2}(k_{i+1}^n + k_{i-1}^n) + \frac{dt}{2dx}(q_{i-1}^n - q_{i+1}^n)$$

The equation can also be modified as

$$k_i^{n+1} = \frac{1}{2}(k_{i+1}^n + k_{i-1}^n) + \frac{dt}{dx} \left(\frac{q_{i-1}^n + q_i^n}{2} - \frac{q_i^n + q_{i+1}^n}{2} \right)$$

$$k_j^{n+1} = \frac{1}{2}(k_{i+1}^n + k_{i-1}^n) + \frac{dt}{dx}(Q_{i-1}^n - Q_i^n)$$

where $Q_{i-1}^n = \frac{q_{i-1}^n + q_i^n}{2}$

$$Q_i^n = \frac{q_i^n + q_{i+1}^n}{2}$$

It can be represented graphically as

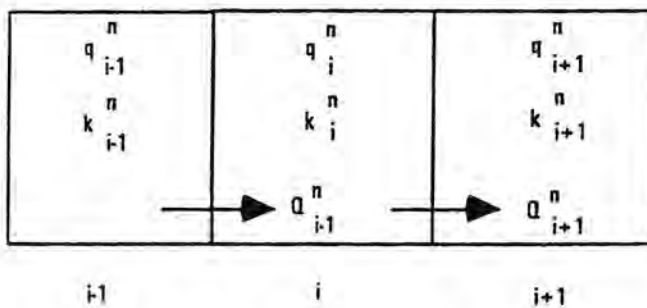

This equation is applied directly to each Δx where there is no internal boundary. However, there is an internal boundary if capacities of two consecutive Δx 's are different as in the case of incident

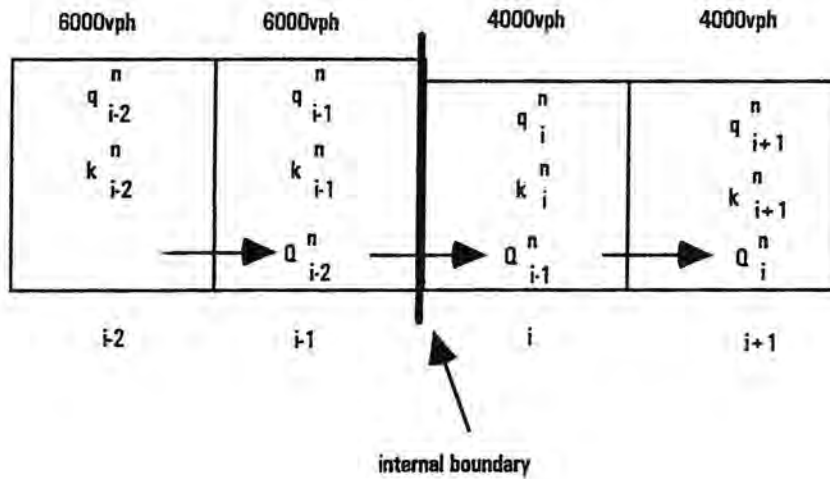

The densities of Δx 's "i-1" and "i" at next time step "n+1" is then calculated as

$$k_{i-1}^{n+1} = \frac{1}{2}(k_{i-2}^n + k_{i-1}^n) + \frac{dt}{\Delta x}(Q_{i-2}^n - Q_{i-1}^n)$$

$$k_i^{n+1} = \frac{1}{2}(k_i^n + k_{i+1}^n) + \frac{dt}{\Delta x}(Q_{i-1}^n - Q_i^n)$$

where $Q_{i-2}^n = \frac{q_{i-2}^n + q_{i-1}^n}{2}$

$$Q_i^n = \frac{q_i^n + q_{i+1}^n}{2}$$

The flow across the boundary is determined as follows:

$$Q_{i-1}^n = \min(Q_{in}, Q_{out})$$

$$Q_{in} = q_{i-1}^n (k_{i-1}^n \leq kcr_{i-1})$$

$$Q_{in} = q \max_{i-1} (k_{i-1}^n > kcr_{i-1})$$

$$Q_{out} = q \max_i (k_i^n \leq kcr_i)$$

$$Q_{out} = q_i^n (k_i^n > kcr_i)$$

where Q_{in} is the upstream input flow determined from Figure 2-18.

Q_{out} is the downstream output flow determined from Figure 2-19.

$q \max_i$ is the capacity flow of Dx "i"

kcr_i is the critical density of Dx "i"

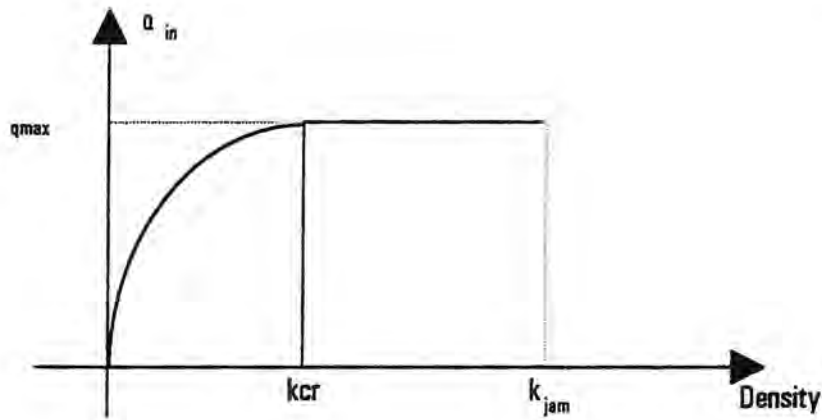

Figure 2-18 Relationship between Q_{in} and upstream segment density

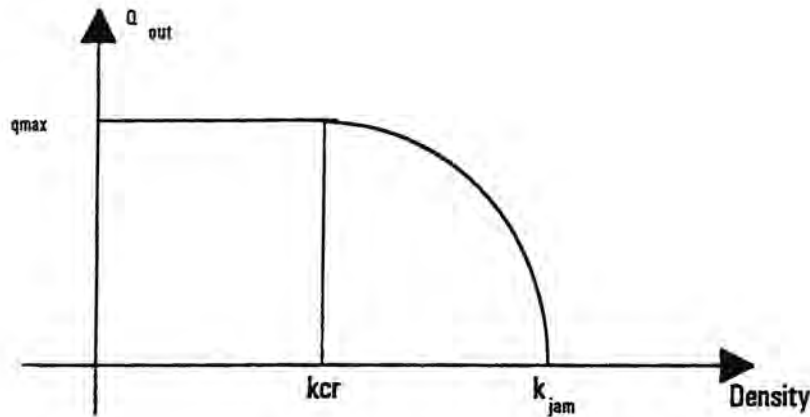

Figure 2-19 Relationship between Q_{out} and downstream segment density

The step-by-step algorithm of multi-stage incident model is as follows:

For each time step of the incident time period before recovering time period,

Step 1: check whether it is the stage transaction time, if yes go to step 2, else go to step 3:

Step 2: determine the q-k curve of the incident area with the new capacity of that stage and determine the density of each dx within the incident area as one of the following cases:

a) if new capacity is greater than the old one, use the current flow to determine the new density with the new q-k curve,

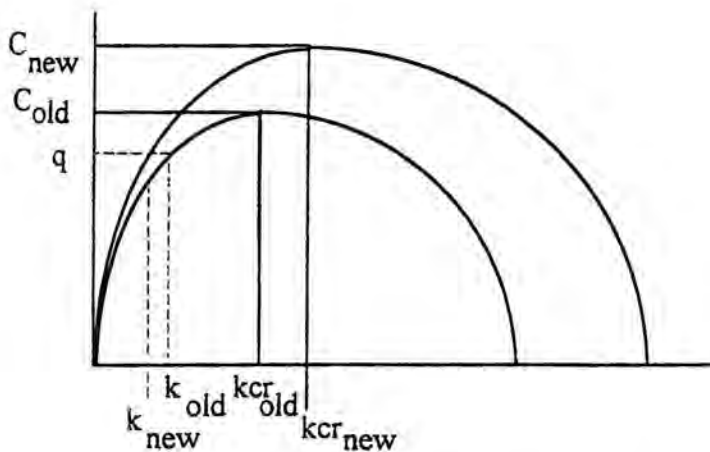

Figure 2-20 Case for increase in Capacity

b) if new capacity is less than the old one, and if current flow is less than the new capacity, use the current flow to determine the new density with the new q-k curve; otherwise use the current flow times the new capacity to old capacity ratio to determine the new density with the new q-k curve.

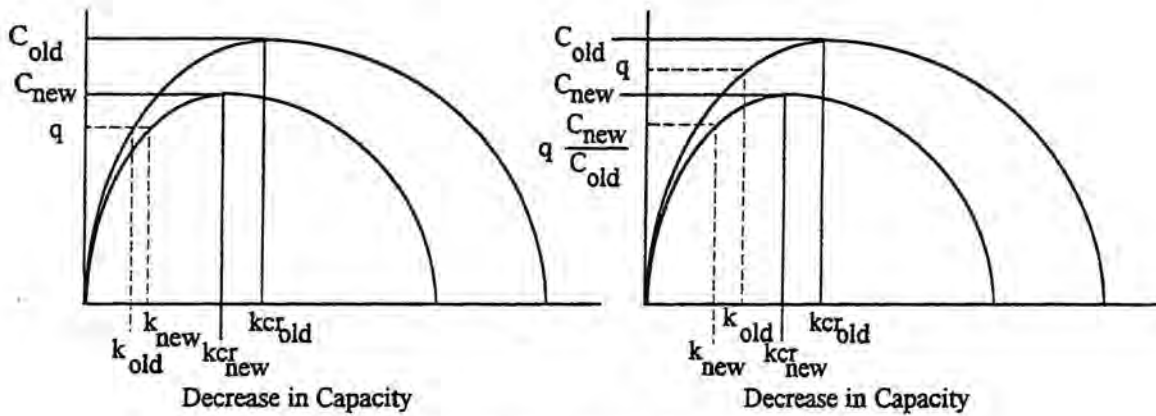

Figure 2-21 Cases for capacity decrease

(If the current density is greater than the critical density of the old q-k curve, use the congested region of the new q-k curve, otherwise use uncongested region).

Step 3: calculate density of each dx at next time step "n+1" by using the original Lax equation for normal Dx 's and the modified one for the internal boundary Dx 's.

For the recovering time period, calculate the density of each dx as the steps described above.

Also increase the capacity linearly for each minute interval.

II.5 Development of diversion treatment module at exit ramps

The previous version of KRONOS did not have the capability to reflect traffic diversion at exit ramps when there is a severe congestion downstream. Further, in the case of the simple off-ramp, the spillback from the exit ramp was combined with the mainline flow, which made it difficult to evaluate the effects from the capacity restriction at exit ramp boundaries. In this research, the simple off-ramp modeling methodology is extensively enhanced to handle diversion and spillback from the exit ramp. The geometry of the simple off-ramp segment is shown as follows:

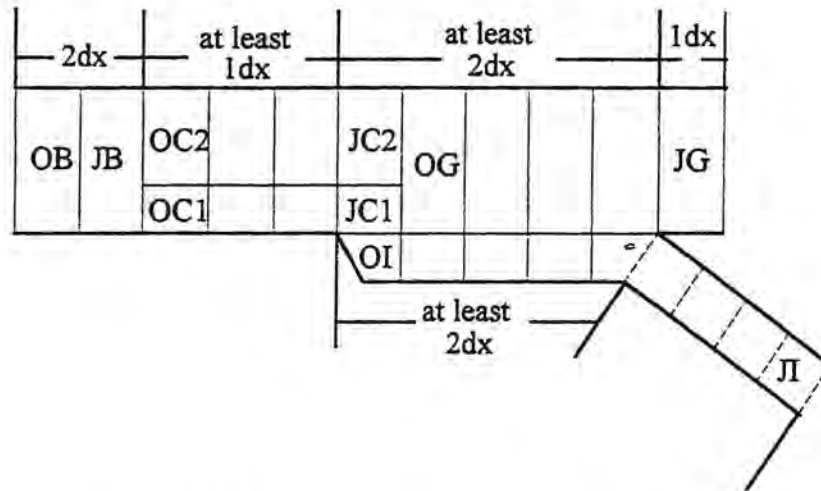

Figure 2-22 Space discretization for off-ramp area

The step-by-step algorithm of the new modeling methodology for the simple off-ramp with diversion is as follows:

- (a) Node OB and JG are treated as boundaries to deal with the capacity variations between different segments:

$$k_{OB}^{n+1} = \frac{1}{2}(k_{OB}^n + k_{JB}^n) + \frac{dt}{dx} (Q - \frac{q_{OB}^n + q_{JB}^n}{2})$$

where $Q = \min(Q_{in}, Q_{out})$

$$Q_{in} = q_{OB-1}^n (k_{OB-1}^n \leq kcr_{OB-1})$$

$$Q_{in} = q \max_{OB-1} (k_{OB-1}^n > kcr_{OB-1})$$

$$Q_{out} = q \max_{OB} (k_{OB}^n \leq kcr_{OB})$$

$$Q_{out} = q_{OB}^n (k_{OB}^n > kcr_{OB})$$

$$k_{JG}^{n+1} = \frac{1}{2} (k_{JG-1}^n + k_{JG}^n) + \frac{dt}{dx} \left(\frac{q_{JG-1}^n + q_{JG}^n}{2} - Q \right)$$

$$\text{where } Q = \min(Q_{in}, Q_{out})$$

$$Q_{in} = q_{JG}^n (k_{JG}^n \leq kcr_{JG})$$

$$Q_{in} = q \max_{JG} (k_{JG}^n > kcr_{JG})$$

$$Q_{out} = q \max_{JG+1} (k_{JG+1}^n \leq kcr_{JG+1})$$

$$Q_{out} = q_{JG+1}^n (k_{JG+1}^n > kcr_{JG+1})$$

(b) Node JB, OC1 and OC2 are treated as internal boundaries where one flow changes to two flows:

$$k_{JB}^{n+1} = \frac{1}{2} (k_{OB}^n + k_{JB}^n) + \frac{dt}{dx} \left[\frac{q_{OB}^n + q_{JB}^n}{2} - (Q_1 + Q_2) \right]$$

$$\text{where } Q_1 = \min(Q_{in1}, Q_{out1})$$

$$Q_{in1} = Q_{ramp} (Q_{ramp} \geq Q_{off})$$

$$Q_{in1} = \min(Q_{JB}, Q_{off}) (Q_{ramp} \geq Q_{off})$$

$$Q_{ramp} = \frac{Q_{JB}}{LN_{JB}}$$

LN_{JB} = number of lane at node JB

$$Q_{JB} = q_{JB}^n (k_{JB}^n \leq kcr_{JB})$$

$$Q_{JB} = q \max_{JB} (k_{JB}^n > kcr_{JB})$$

$$Q_{off} = q_{off} + q_{OB}^n \cdot q_{div}$$

q_{off} , = exit demand given by data input

q_{div} = diversion percentage given by data input

$$Q_{out1} = q \max_{OC1} (k_{OC1}^n \leq kcr_{OC1})$$

$$Q_{out1} = q_{OC1}^n (k_{OC1}^n > kcr_{OC1})$$

$$Q_2 = \min(Q_{in2}, Q_{out2})$$

$$Q_{in2} = Q_{JB} - Q_{in1} \text{ if no capacity restriction at exit ramp}$$

$$Q_{in2} = \min(Q_{JB} - Q_{in1}, Q_{TD}, q \max_{OC2}) \text{ if capacity restriction at exit ramp}$$

$$Q_{out2} = q \max_{OC2} (k_{OC2}^n \leq kcr_{OC2})$$

$$Q_{out2} = q_{OC2}^n (k_{OC2}^n > kcr_{OC2})$$

$$k_{OC1}^{n+1} = \frac{1}{2}(k_{OC1}^n + k_{OC1+1}^n) + \frac{dt}{dx} (Q_1 - \frac{q_{OC1}^n + q_{OC1+1}^n}{2})$$

$$k_{OC2}^{n+1} = \frac{1}{2}(k_{OC2}^n + k_{OC2+1}^n) + \frac{dt}{dx} (Q_2 - \frac{q_{OC2}^n + q_{OC2+1}^n}{2})$$

(c) Node JC1, JC2, OI and OG are the internal boundaries where one lane flow exits into the

deceleration lane and two flows change back to one flow:

$$k_{JC1}^{n+1} = \frac{1}{2}(k_{JC1-1}^n + k_{JC1}^n) + \frac{dt}{dx} [\frac{q_{JC1-1}^n + q_{JC1}^n}{2} - (Q_{OI} + Q_{OG1})]$$

$$\text{where } Q_{OI} = \min(Q_{in_{OI}}, Q_{out_{OI}})$$

$$Q_{in_{OI}} = \min(Q_{JC1}, Q_{off})$$

$$Q_{JC1} = q_{JC1}^n (k_{JC1}^n \leq kcr_{JC1})$$

$$Q_{JC1} = q \max_{JC1} (k_{JC1}^n > kcr_{JC1})$$

$$Q_{off} = q_{off} + q_{OB}^n \cdot q_{div}$$

$$q_{off}, = \text{exit demand given by data input}$$

$$q_{div} = \text{diversion percentage given by data input}$$

$$Q_{out_{OI}} = q \max_{OI} (k_{OI}^n \leq kcr_{OI})$$

$$Q_{out_{OI}} = q_{OI}^n (k_{OI}^n > kcr_{OI})$$

$$Q_{OG1} = \min(Q_{in_{OG1}}, Q_{out_{OG1}})$$

$$Q_{in_{OG1}} = 0 (Q_{in_{OI}} > Q_{out_{OI}})$$

$$Q_{in_{OG1}} = Q_{JC1} - Q_{in_{OI}} (Q_{in_{OI}} \leq Q_{out_{OI}})$$

$$Q_{out_{OG1}} = \frac{q \max_{OG}}{LN_{OG}} (k_{OG}^n \leq kcr_{OG})$$

$$Q_{out_{OG1}} = \frac{q_{OG}^n}{LN_{OG}} (k_{OG}^n > kcr_{OG})$$

$$k_{JC2}^{n+1} = \frac{1}{2} (k_{JC2-1}^n + k_{JC2}^n) + \frac{dt}{dx} \left(\frac{q_{JC2-1}^n + q_{JC2}^n}{2} - Q_{OG2} \right)$$

where $Q_{OG2} = \min(Q_{in_{OG2}}, Q_{out_{OG2}})$

$$Q_{in_{OG2}} = q_{JC2}^n (k_{JC2}^n \leq kcr_{JC2})$$

$$Q_{in_{OG2}} = q \max_{JC2} (k_{JC2}^n > kcr_{JC2})$$

$$Q_{out_{OG2}} = q \max_{OG} \frac{LN_{OG} - 1}{LN_{OG}} (k_{OG}^n \leq kcr_{OG})$$

$$Q_{out_{OG2}} = q_{OG}^n \frac{LN_{OG} - 1}{LN_{OG}} (k_{OG}^n > kcr_{OG})$$

$$k_{OG}^{n+1} = \frac{1}{2} (k_{OG}^n + k_{OG+1}^n) + \frac{dt}{dx} \left[(Q_{OG1} + Q_{OG2}) - \frac{q_{OG}^n + q_{OG+1}^n}{2} \right]$$

$$k_{OI}^{n+1} = \frac{1}{2} (k_{OI}^n + k_{OI+1}^n) + \frac{dt}{dx} \left(Q_{OI} - \frac{q_{OI}^n + q_{OI+1}^n}{2} \right)$$

(d) Node II is treated as internal boundaries if capacity restriction is applied on exit ramp, otherwise, it is treated as normal node and the density, speed and flow are calculated by normal Lax equation. For capacity restriction, density of node II is calculated as:

$$k_{II}^{n+1} = \frac{1}{2} (k_{II-1}^n + k_{II}^n) + \frac{dt}{dx} \left(\frac{q_{II-1}^n + q_{II}^n}{2} - Q_{exit} \right)$$

where $Q_{exit} = \min(CAP_{exit}, Q_{II})$

CAP_{exit} = restricted capacity of the exit ramp given by data input

$$Q_{II} = q_{II}^n (k_{II}^n \leq kcr_{II})$$

$$Q_{II} = q \max_{II} (k_{II}^n > kcr_{II})$$

II.6 Enhancement of the user interface

The input/output modules of KRONOS have also been enhanced to support the new simulation features added in this research. Further, the enhanced input/output modules are based on the mouse-driven, window-type screen structure, which is the major enhancement over the previous version. Using the mouse, the user can enter data and navigate the system much more quickly and efficiently. It also makes the user interface much more intuitive. The new enhanced version runs under the DOS environment.

Another major advancement is the addition of the capability to simulate a merging and a diverging freeway. The input module allows the user to create both merging and diverging freeways in the same way that the main freeway is created. Data like capacity, initial flow, and demand can be created for each freeway section. Buttons are located in each screen to allow the user to select which freeway section to work on. All off ramps now have an additional page in the demand data section to input the time-dependent diversion rates, which are the percentage of the additional traffic volume that exits the freeway at that off ramp in addition to the original demand. These diversion rates can be specified at all off ramps including weaving sections and CD-Road sections. The default value for the diversion rate is 0%. Integers in the range 0 to 100 can be entered for each diversion rate input box.

The output module also takes advantage of the mouse with the buttons for mainline, merging, and diverging sections. For each freeway section, user can create 2-/3-dimensional graphics and the spread-sheet type output files for Lotus. The simulation module provides separate information for each section, and the output module can then display the data separately. The new user interface developed in this research is designed to handle up to 20-mile freeway including main, merging and diverging freeway sections.

II.7 Development of a dynamic memory allocation module

The current version of KRONOS is limited by the 640 KB maximum RAM of DOS. This limits the maximum freeway size that could be simulated to 20 miles. In this research, an initial step was taken to convert KRONOS from the DOS environment to Windows-environment that is not restricted by 640 kb limitation. A prototype version of the dynamic memory allocation module to improve the current static memory allocation configuration is developed and its feasibility for full scale implementation was studied. Further, the enhanced simulation module was compiled with the Microsoft C++7.0 Windows version to be run under the Windows environment. The resulting temporary window-version runs the input and output modules as DOS applications, and the simulation module as an window application. The development of Windows-based user interface has not been performed in this research, since it requires a substantial amount of work beyond the scope of the current phase.

Temporary windows version

The input module and the simulation program are run as two separate programs under Windows. Icons are set up to run both programs by double clicking on the icon. The input module runs as a DOS program under windows. The input module is used to select a freeway configuration to be simulated and to save the input file needed for the simulation. Choosing "run simulation" sets up the files needed for the simulation and exits the input program. A file is written out which contains the input information needed for dynamic memory allocation by the simulation program. The simulation program is then run by clicking on the simulation icon. Information on the progress of the simulation is displayed in the window in which the simulation program is running. The simulation can be paused and restarted using the available menu items.

Dynamic memory allocation module

To increase the available memory, and thus the maximum freeway simulation length, the memory allocation scheme of KRONOS was changed from static to dynamic so that the amount

of available memory is allocated when the simulation starts rather than when the program is compiled. The maximum freeway length can be determined by the size of the memory available on the machine when the simulation is run. This will vary with the individual machine configuration, i.e., the size of RAM installed and other programs running concurrently under Windows. In this research, the declarations of the data structure in the simulation module were changed from static variables to pointers, and the new code was added to allocate memory for the needed arrays. The source code for the dynamic memory allocation is attached in Appendix A. It has been identified that the current data structure in the simulation module is not very efficient for dynamic memory allocation. It is recommended that, in order to take full advantage of the dynamic memory management and for the future addition of new simulation functions, the source code of the simulation module needs to be reorganized under object-oriented programming environment. A preliminary study to develop an object-oriented simulation structure was performed and the resulting skeleton object definition of the simulation module source code is attached in Appendix B.

II.8 Summary

This chapter summarized the enhancements of KRONOS performed in this research. In particular, new traffic modules to treat special weaving segment and two-freeways with a common section were developed and incorporated into the simulation module. The incident module was enhanced to reflect time-dependent capacity variations in the incident zone. Further, the new user interface developed in this research is based on the mouse-driven, pop-up menu screen structure, which is much more efficient than the previous version. A prototype dynamic memory allocation module was also developed for more efficient use of the memory and the enhanced source code of the simulation module was compiled with Microsoft C7.0 under the Windows-environment. The limited application of the dynamic memory allocation scheme indicated the possibility of handling long freeway sections in terms of simulation. However, to

take full advantage of the dynamic memory management, it is recognized that the source code of the simulation module needs to be reorganized under the object-oriented programming environment and the input/output modules also need to be converted to the windows applications.

III. DEVELOPMENT OF A STANDARD PROCEDURE FOR TESTING AND VALIDATION OF TRAFFIC MODELS

III.1 Introduction

A traffic model should be tested and validated under various traffic conditions prior to its application. Validation is to see whether there is an adequate agreement between the model and the traffic system being modeled. It involves a quantitative comparison between the behavior of a model and the real traffic flow process that the model tries to represent. While testing and validation is of critical importance for traffic models, it is very difficult, if not impossible, to perform an exhaustive testing for a given model with all possible traffic conditions. In this chapter, a systematic procedure to test the traffic models in KRONOS is developed. First, a set of representative traffic conditions is identified, i.e., uncongested and congested cases. Secondly, specific test cases for each condition are developed and stored in a database for future comparison. The test cases developed in this research include both hypothetical and real cases when the data is available.

III.2 Development of A Framework For Standard Testing Procedure

The current version of KRONOS can simulate 25 different types of geometrics (Figure 3-1). These different types of geometrics are basic elements building the real freeway system. If one of these elements does not function as expected, the whole freeway system consisting of various segment types can not be simulated. In this research, two procedures were developed to test the performance of traffic models: qualitative testing with hypothetical cases and quantitative testing with real data sets. First, hypothetical cases for testing individual segments were developed with different flow conditions. For each segment type, the qualitative traffic performance in terms of flow conservation and congestion spillback are examined with hypothetical data sets. After all the segment types are tested individually, a hypothetical freeway system consisting of all the

segment types is created and the overall performance of the combined system are tested in terms of flow conservation and flow transition at each internal boundaries.

After testing models with the hypothetical cases, the quantitative testing with real data set can be performed and the difference between observed data and estimated values by the models can be measured. Before applying the models with real data, the simulation parameters, such as flow-density relationship, need to be calibrated. To facilitate the manual calibration process, a computer software is written to automatically calculate the difference between measured traffic volume by detectors and estimated volume at the detector locations. Using this procedure, the iterative process to calibrate flow-density relationships can be performed more systematically. Figure 3-2 illustrates the framework of the test procedure developed in this research .

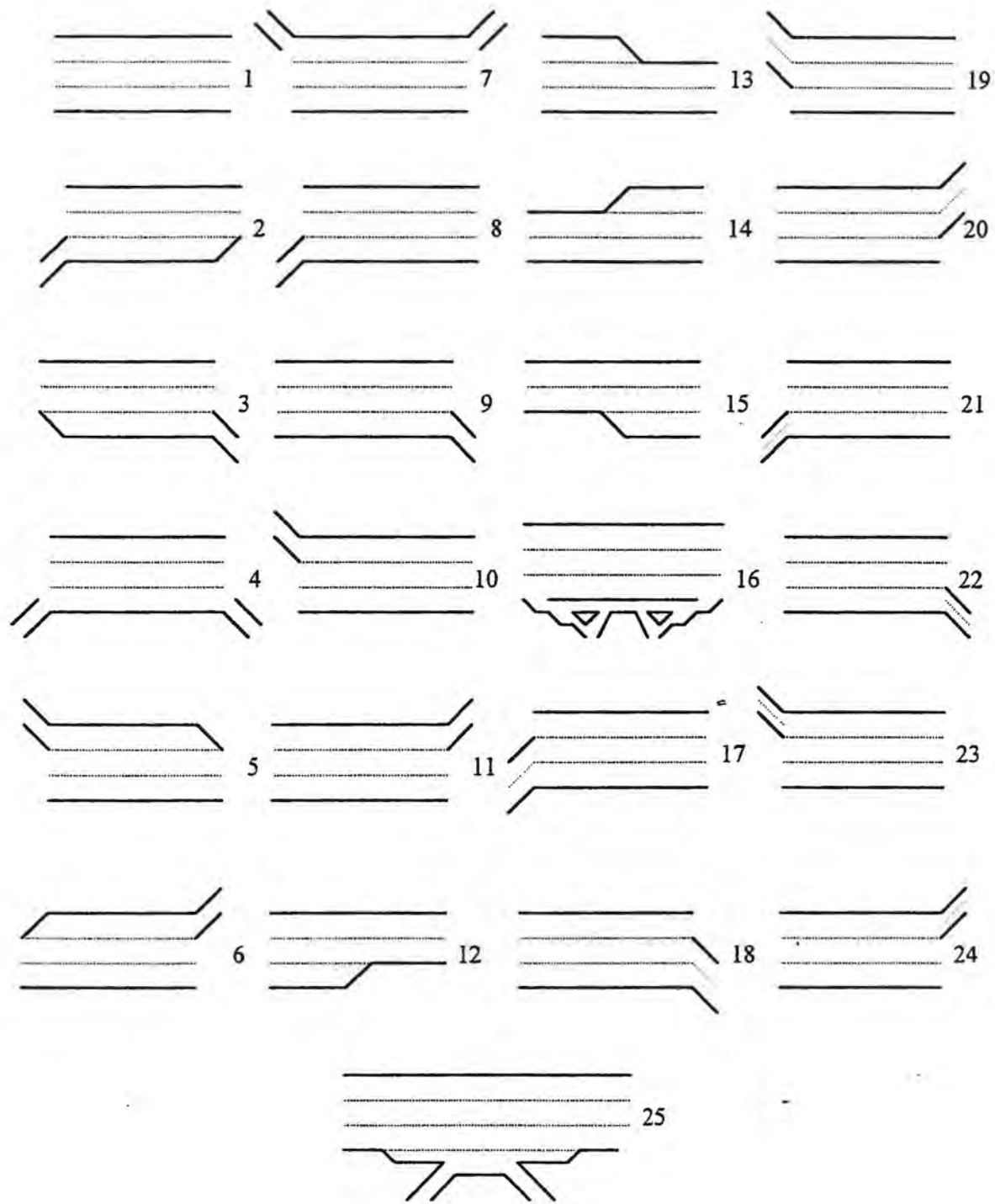

* Number indicates the type number.

Figure 3-1 Geometric segment types in KRONOS

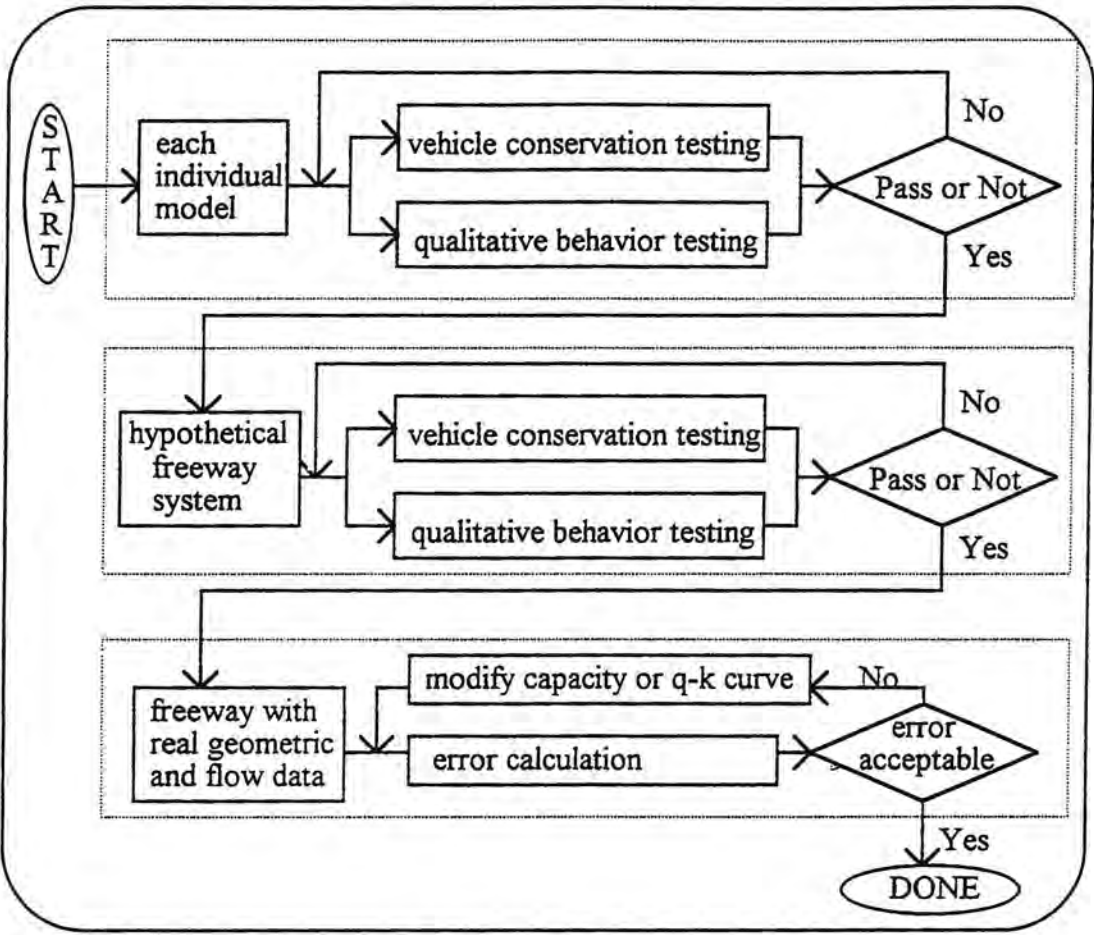

Figure 3-2 Framework of the test procedure

III.3 Development of Test Cases For Qualitative Testing

Two hypothetical situations are created for each segment type to examine the qualitative behavior of the model performance: uncongested and congested cases. To create congestion, the exit volume at the downstream boundary of the mainline freeway is restricted to be less than the arrival volume at upstream boundary. If a segment type includes ramps, the on-ramp metering and off-ramp capacity restriction options are also tested. The testing criterion for hypothetical case is flow conservation under various conditions for individual segment. The input flow, which is the sum of the upstream input flow and on-ramp input flow, must equal the output flow when the freeway reaches equilibrium. The later is the sum of the downstream output flow and off-ramp output flow. The model's behavior such as spillback propagation under congested conditions will be evaluated qualitatively. Appendix C includes the test cases for each segment type.

After the testing of individual segments is finished, the testing of a freeway system with all possible segment types can be performed. Figure 3-3 shows the hypothetical test section combining most segment types available in the current version. Appendix C also includes the detailed data for this section including the traffic demand pattern in the format of the KRONOS input file. Using this section, the transition of traffic volume and density at each internal boundaries between segments can be examined.

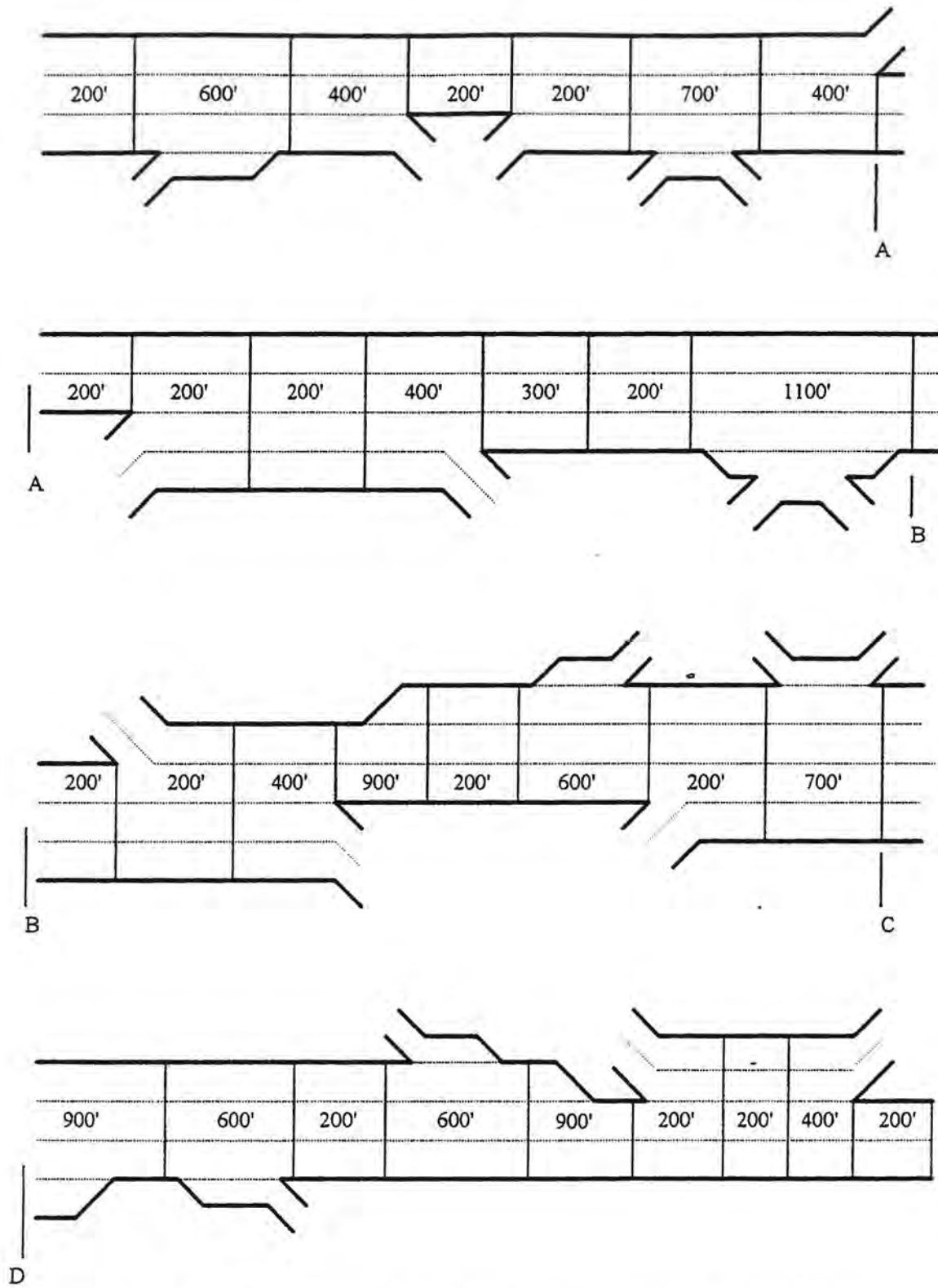

Figure 3-3 Geometrics of a hypothetical integrated freeway system

III.4 Development of test cases for quantitative testing

In this section, the test cases with real data are developed for quantitative testing of the traffic models. Based on the available freeway geometrics and demand data, four cases have been developed:

- Case 1 (named as 35WPIPE): The test section is taken from southbound I-35W freeway close to downtown Minneapolis. It starts at 26th street and ends at 31st street, and carries heavy traffic from downtown Minneapolis during the afternoon peak hour. Figure 3-4 shows the geometrics. There are three detector stations located along this long pipeline section: the first one is located at 26th street (26S), the second one is located at 28th street (28S), and the third and the last is located at 31st street (31S). The data from 26S is used as the upstream boundary, and that from 31S is used as downstream boundary. Detector station 28S is used as a check station. The field data used was obtained between 4:00pm and 6:30pm with 5 minutes interval on November 14 and November 20, 1989.

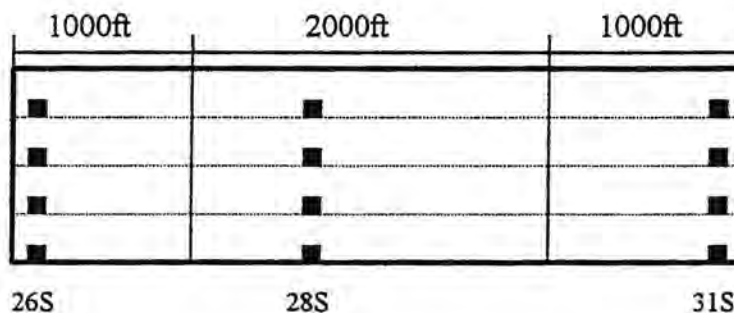

Figure 3-4 Freeway geometrics for case 1 (35WPIPE)

- Case 2 (named as 494W): This case represents I-494 westbound section from Nicollet Avenue to I394. The freeway section has a total length of 12 miles with 18 entrance ramps and 18 exit ramps. The whole section is divided into 60 segments. Figure 3-5 shows the length and the geometrics of the freeway and the location of the detector stations. Volume data was

collected by the Traffic Management Center on May 25, 1993 from 4:45am to 11:45am . It includes morning peak hours starting from 7:00 to 9:00am. From the occupancy data, a very small congestion from station 182 to station 119 was detected: the volume and occupancy began to increase at 7:30am, and began to decrease at 8:30am. The simulation uses 15-minute volume data. The speed data was not available at the time of testing.

- Case 3 (named as 35WN): This case represents I-35w northbound from 86th street to 28th street on November 7, 1989. The freeway section has a total length of 8.14 miles with 12 entrance and 10 exit ramps. There are total 37 segments. Figure 3-6) show the geometrics used in this case. The data was collected on a 5 minutes interval basis, starting from 6:00am to 9:00am which included the morning peak hour. It contained both the transitions from free-flow into congestion and from congestion back into a free-flow condition. At most stations, the peak flow was observed from 7:15am to 8:00am. Based on the occupancy data, congestion was detected from station 63n to 53n from 7:00am to 8:00am.
- Case 4 (named as 35W62E): This case represents I-35w northbound at the crosstown area in Minneapolis, Minnesota, where interstate freeway 35W northbound and highway 62 eastbound merges, then diverges. Due to the detector failure on the merging section, only diverging section is included here. This section has a total length of 2 miles with 11 segments in this freeway section. Figure 3-7 shows the geometrics and the detector locations. The data was collected on a 5 minutes interval basis starting from 6:00pm to 7:00pm on December 16, 1993.

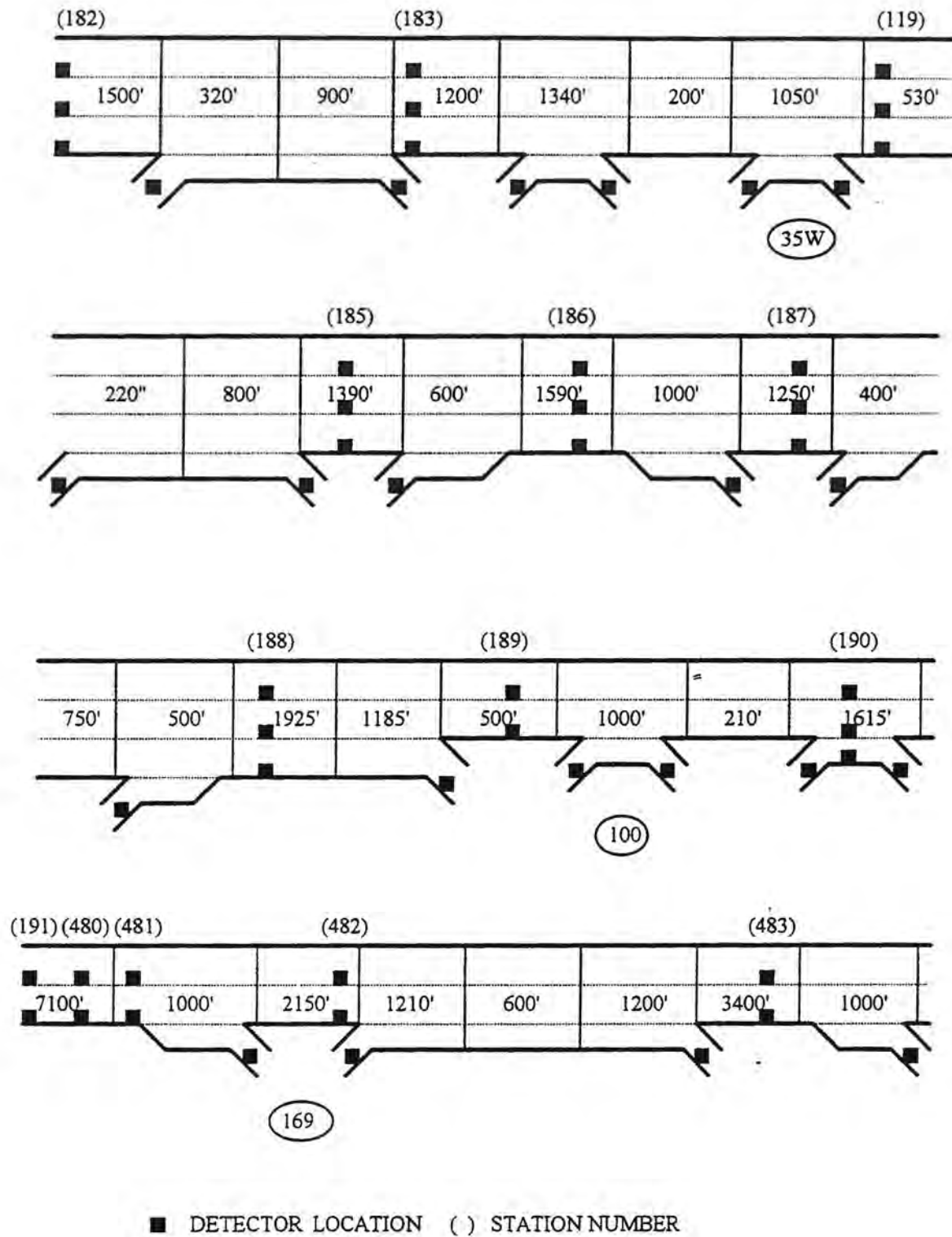
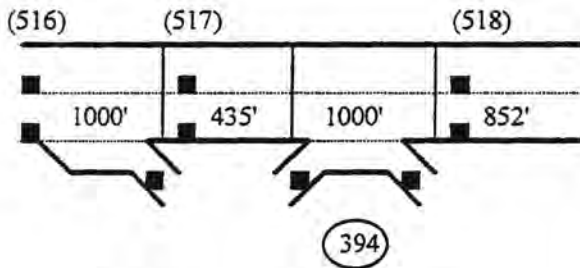
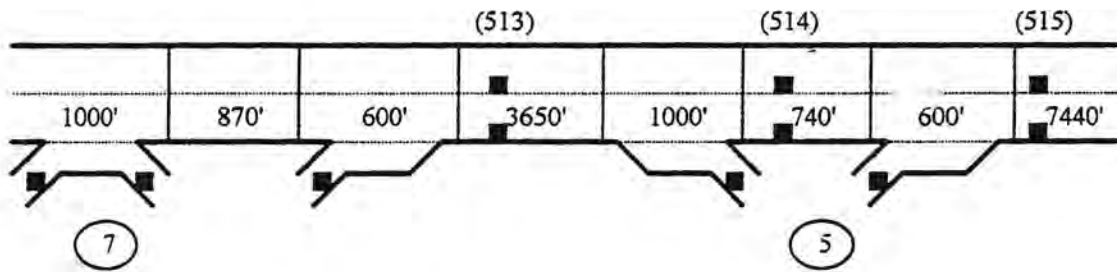
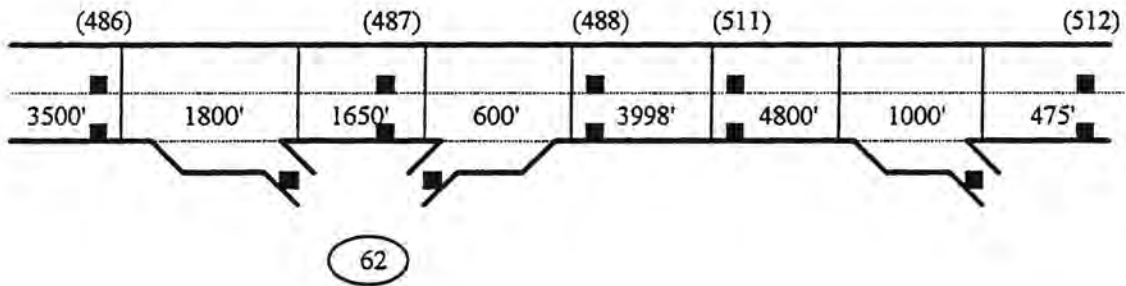
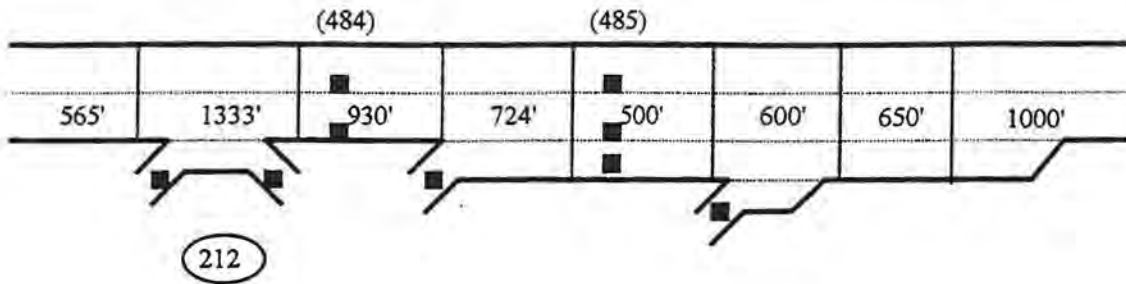

Figure 3-5 Freeway Geometrics of Case 494W (I494 Westbound) -- continued on next page



■ DETECTOR LOCATION () STATION NUMBER ○ CROSSING HIGHWAY NUMBER

Figure 3-5 Freeway Geometrics of Case 494W (continued) (distance in feet)

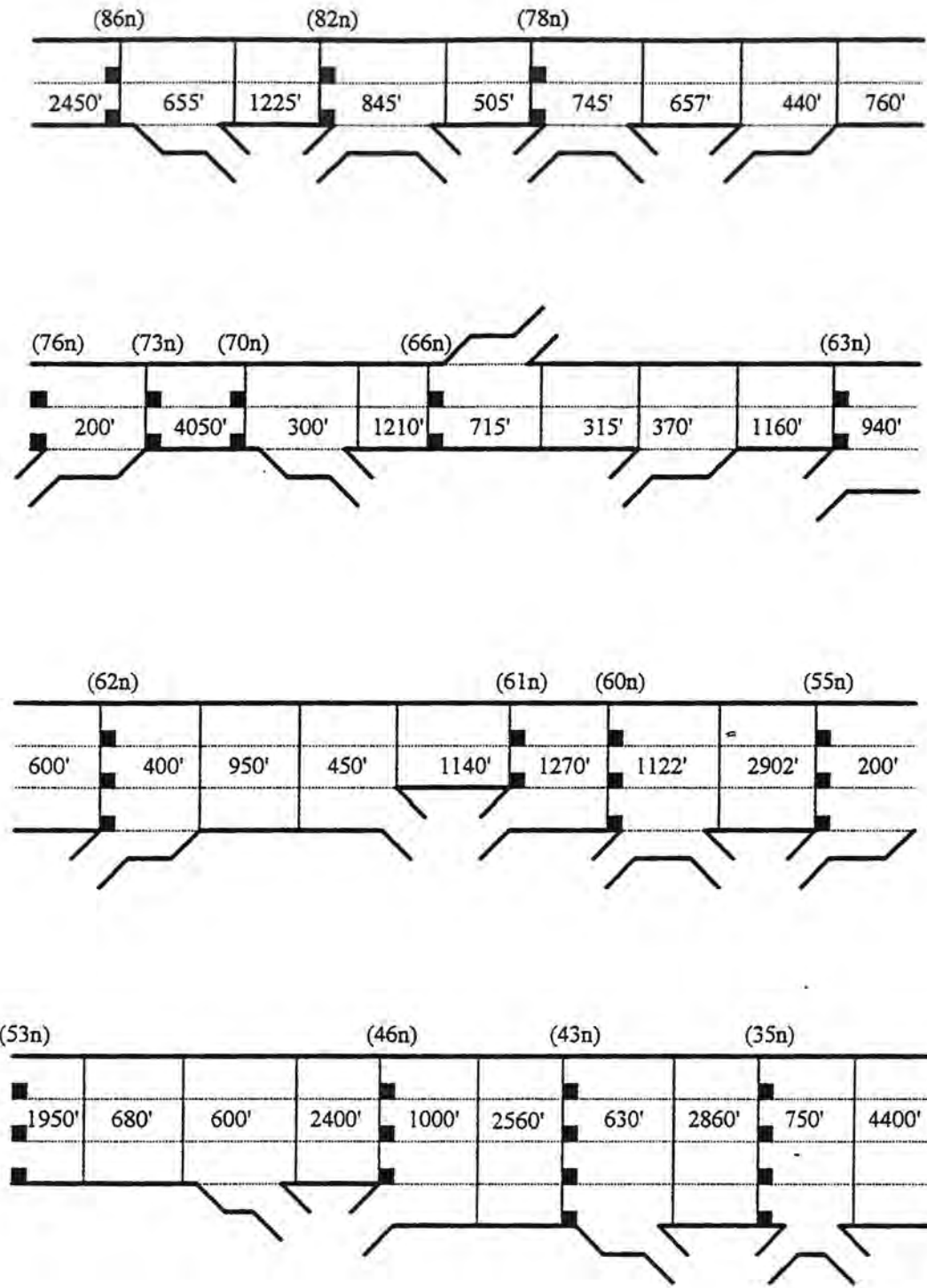

Figure 3-6 Geometrics of Case 35WN (distance in feet)

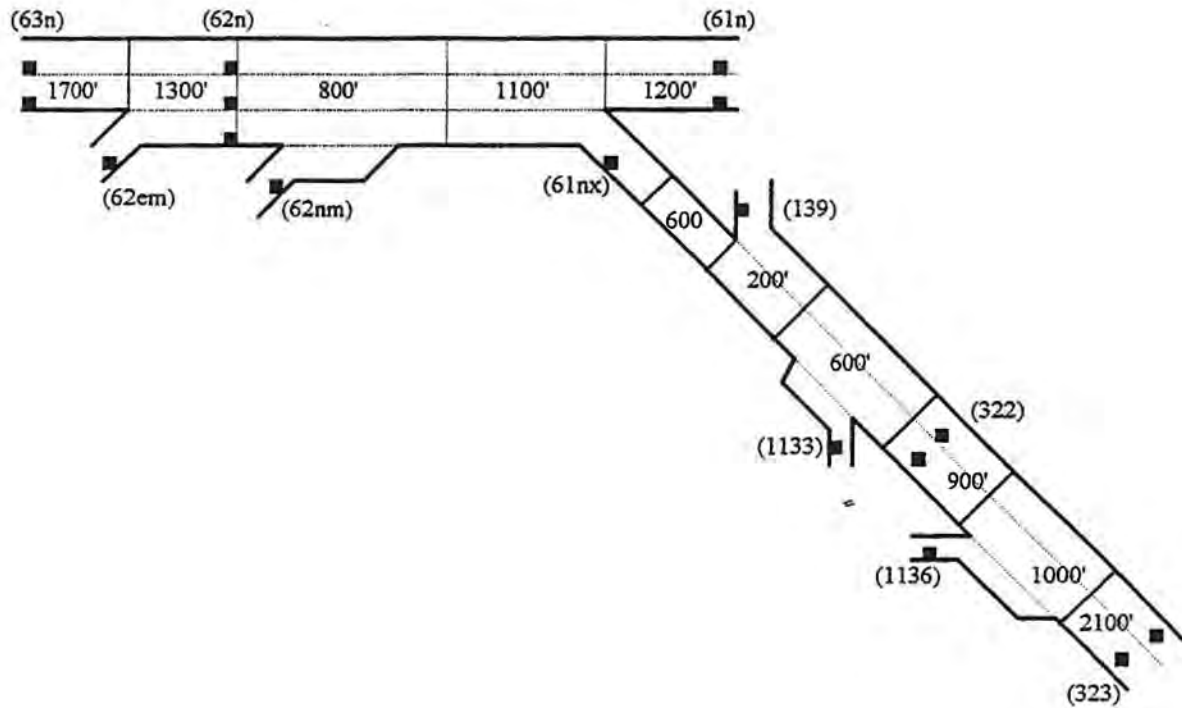

Figure 3-7 Geometrics of Case 35W62E (distance in feet)

III.5 Manual calibration procedure for flow-density relationship

KRONOS adopts the simple continuum modeling approach, where the flow-density (q-k curve) or speed-density (u-k curve) relationship is one of the major parameters affecting the simulation results. The program requires a basic q-k relationship in terms of three coordinates in the q-k plane. The program automatically scales up or down the basic q-k relationship according to the given values of capacities for each segment. It is the adjusted q-k relationship that the program uses to estimate flow and speed during the simulation. Therefore, it is very important to have correct capacity values for each segment and an appropriate q-k relationship.

Currently, there is no procedure which can automatically calibrate the q-k relationship for a given freeway section. The calibration has to be done manually on a trial-and-error basis by iteratively adjusting those values based on the difference between real data and simulation results. A computer program called **ETABLE** was specifically developed for comparing detector data with simulation results. The program creates an error table for all checking points along the given section. The procedure of using **ETABLE** is as follows: (Figure 3-8 shows the flow chart of this procedure)

- Step 1: prepare an input data file with one complete set of real detailed geometrics data for a given freeway section. The data, in terms of demand pattern, should include all external boundary condition, i.e., upstream/downstream boundary volume and flow condition, on-ramp and off-ramp volumes. All these volume and occupancy data should come from on-line detectors.
- Step 2: run KRONOS simulation module with initial capacity and q-k relationship.
- Step 3: use "create output file for Lotus" option to create output data file from running KRONOS display module individually:
 - a) if you want to compare volume with real data, use the option "total flow vs. distance & time" and then rename lotus1.dat to **result.vol**.

b) if you want to compare speed with real data, use the option "speed vs. distance & time" to create lotus1.dat file and then rename it to **result.spd**.

Because the display module only makes one lotus1.dat file at a time, please first rename lotus1.dat before you run display module the second time.

- Step 4: create comparison data files using detector data: **condata.vol** (for volume) and **condata.spd** (for speed) using the following format:

segment #	detector station #	accumulated distance	volume of 1st time slice	volume of 2nd time slice	volume of last time slice
3	183	3350 ft	3300 veh/hr	4500 veh/hr		5000 veh/hr
10

Make sure there is no blank line at the end of the data file and the maximum number of time slices cannot exceed 30.

- Step 5: create **index.tab** file for the first run with the following format:
 1 (index of error table, it will be updated automatically every time)
 25 (total number of time slices)

- Step 6: run **ETABLE** program:

>**ETABLE**

Have you put simulation data to files named result.vol or result.spd? (y/n) **Y**

Make table for 1: volume, 2: speed, 3: both (1..3) **2**

Making error table for speed

MAE = 123.0 MPD = 12.0

The name of the error table created under the first run is err.v1 and/or err.s1, and the second run is err.v2/err.s2 and so on.

- Step 7: examine the discrepancy between real data and simulation result, then adjust q-k relationship and/or capacity of each segment accordingly.

Repeat Step 2 to Step 6 again and again until the error reaches an acceptable range.

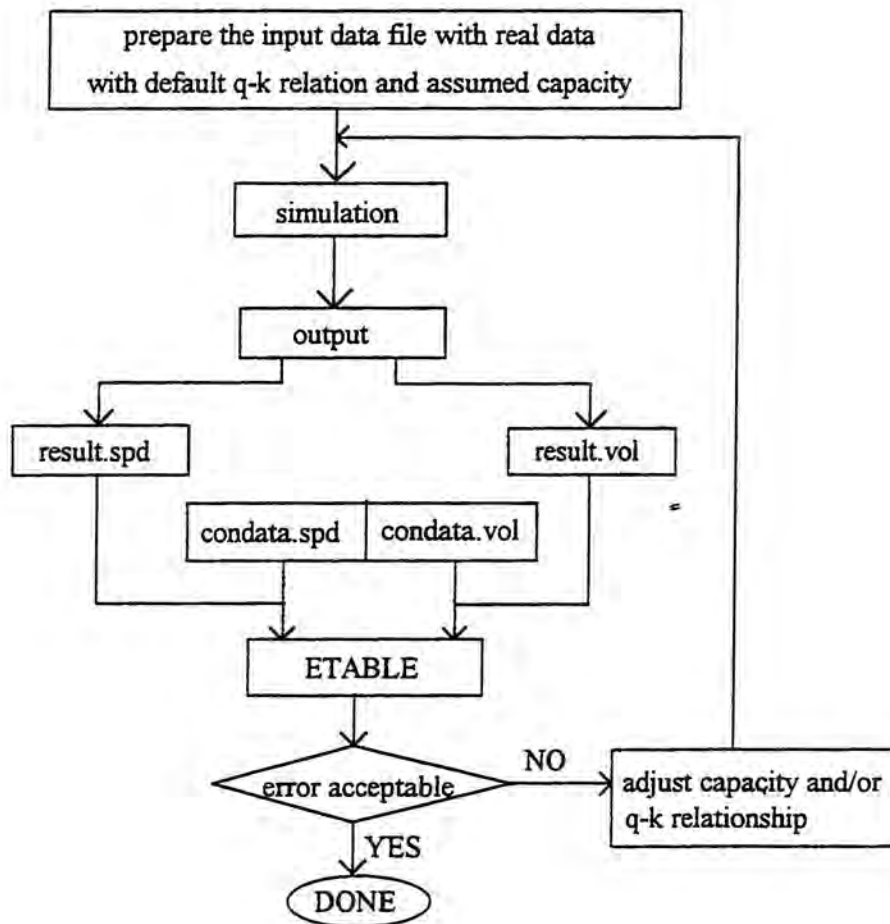

Figure 3-8 Manual calibration procedure flow-density curve

III.6 Summary

This chapter summarized a new procedure to test the traffic models in KRONOS. Both hypothetical and real traffic cases are developed and stored for future testing. Further, a manual calibration procedure for the flow-density relationship, the key parameter in simulation, is also developed. The testing procedure is applied in Chapter IV for example testing of KRONOS.

IV. TESTING AND VALIDATION OF KRONOS WITH PROPOSED TESTING PROCEDURE

IV.1 Introduction

This chapter includes the test results of the new enhanced KRONOS using the procedure developed in Chapter III. In the previous chapter, qualitative testing to examine the model performance in terms of flow conservation and congestion propagation has been performed on each new individual segment. Having determined that the model yielded reasonable results for individual elements of freeway in the qualitative testing, the next step is to integrate all the individual segments into one freeway system and test the model performance in the integrated freeway. The first hypothetical case developed in Chapter III, and a new hypothetical freeway system consisting of merging/diverging freeways are used in this testing. Further, four real test cases developed in Chapter III are also used to evaluate the accuracy of the traffic models quantitatively. For the quantitative evaluation of the model performance with the field data, the following error measurements are calculated (N is the number of measured points):

$$\text{Mean Absolute Error (MAE): } \frac{\sum |Measured - Estimated|_k}{N}$$

$$\text{Percentage Difference (PD: 100%): } \frac{(Measured - Estimated)_k}{Measured_k} \cdot 100\%$$

$$\text{Mean Percentage Difference (MPD: 100%): } \frac{\sum \frac{|Measured - Estimated|_k}{Measured_k} \cdot 100\%}{N}$$

IV.2 Qualitative Testing

The first hypothetical test case for overall qualitative testing was developed in chapter two. It is a combination of all possible different geometrics (Figure 3-3). Test case 1 is an uncongested case with very light volume. Appendix C includes the input file for this test case (allseg.kr8). Figure

4-1 represents the three dimensional mainline density plot where all densities along the freeway are lower than 20 veh/mile. The small variation in density is caused by vehicle-merging at the entrance ramp and vehicle-diverging at the exit ramp. The simulation results indicate the conservation of flow in the last zone. Test case two is a congested case. The demand pattern is shown in the appendix with file name "allseg-d.kr8". Indeed, the flow condition for this case is almost the same as case one except the downstream exit flow is restricted to show spillback propagation. As shown in the density plot of Figure 4-2, the high density is propagated to upstream as the time goes on. The system behaves as expected.

The second sample system is a new hypothetical freeway for testing merging/diverging of two freeways with a common section. The freeway merging module and diverging module were tested separately in chapter five. In order to examine the connection nodes, The two modules need to be combined together and tested again. A test case with hypothetical geometrics and demand pattern is created as shown in Figures 4-3 and 4-4. The simulation was performed for a 30 minute period with 5-minute demand.

As for the demand pattern of the main freeway, the upstream volume is 4000 veh/hr in the first 15 minutes and decreases to 3000 veh/hr in the next 15 minutes. The diverging demand from the main freeway to the diverging section is 800 veh/hr. For the demand pattern of the merging freeway, the upstream volume is 1000 veh/hr and the off-ramp volume is kept at 500 veh/hr for the entire simulation period. The on ramp volume in the diverging freeway is 200 veh/hr. The simulation results showed the expected flow values at the last dx's of the main and diverging freeway sections, i.e., in the mainline, 2,700 veh/hr after 15 minutes and 1000 veh/hr in the diverging section.

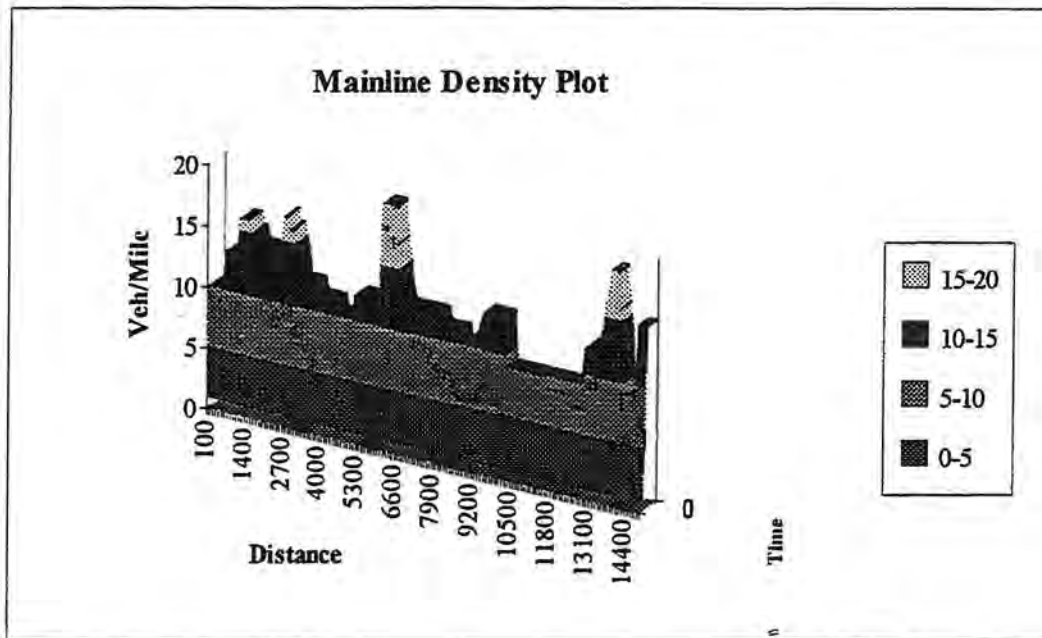

Figure 4-1 Three dimensional mainline density plot for hypothetical case 1

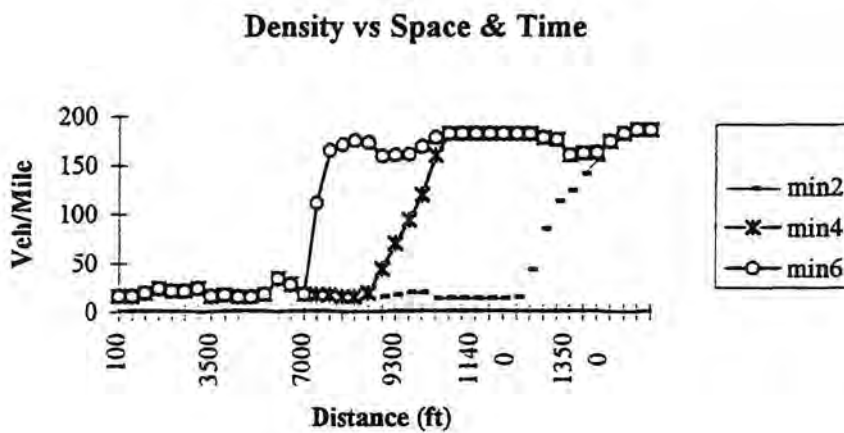

Figure 4-2 Density plot of first six minutes for test case 2

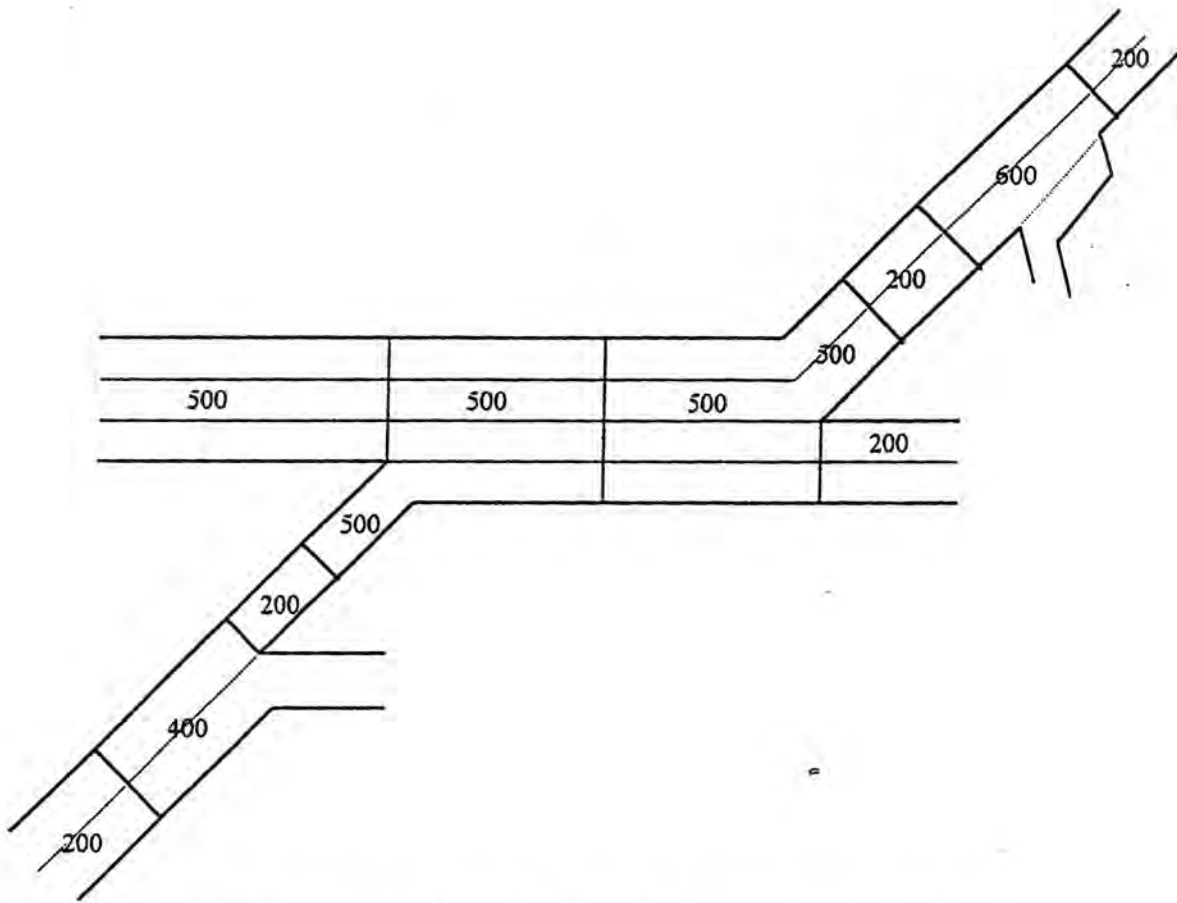

Figure 4-3 Geometrics of merging/diverging freeway testing section

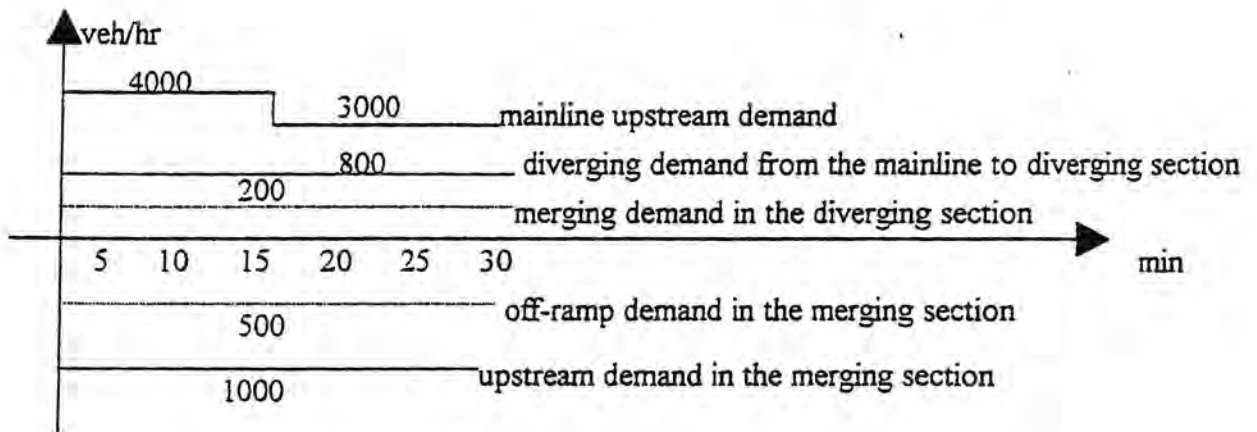

Figure 4-4 Demand pattern of merging/diverging testing section

IV.3 Quantitative Testing

In this section, the four test cases with the field data developed in Chapter III are used to test and validate the new version of KRONOS, which has incorporated the new modeling developed in this research. Each test case was first simulated with the default density-flow relationship and capacity values. The density-flow relationship and capacity values for each segment were adjusted using the trial-and-error method to minimize the difference between the field data and the estimated values from the simulation. The rest of this section presents the testing results of these four cases performed with the new version of KRONOS program.

- Case 1: 35WPIPE case

This case was developed based on the real data measured along I-35w southbound close to the downtown Minneapolis area. It involves a 4000 ft four-lane pipeline freeway section (see Figure 3-4 for reference). It carries heavy traffic coming out of downtown Minneapolis during the afternoon peak hour. The actual traffic data are collected on November 14 and November 20, 1989. Figures 4-5 and 4-6 show the upstream and downstream demand pattern of November 14, 1989 and November 20, 1989. Figures 4-7 and 4-8 show the comparisons between field data and simulation results for station #28S. The closeness between the two sets of values shows that the simulation results match the real data quite well. On November 14, 1989, the absolute percentage differences range from 0.3% to 17.0%. Only one percentage of the error exceeds 10%, and three percentage of the errors exceed 5%. The error for the rest points are lower than 5%. On November 20, the absolute percentage differences range from 0.11% to 8.2%.

Boundary Flow Conditions

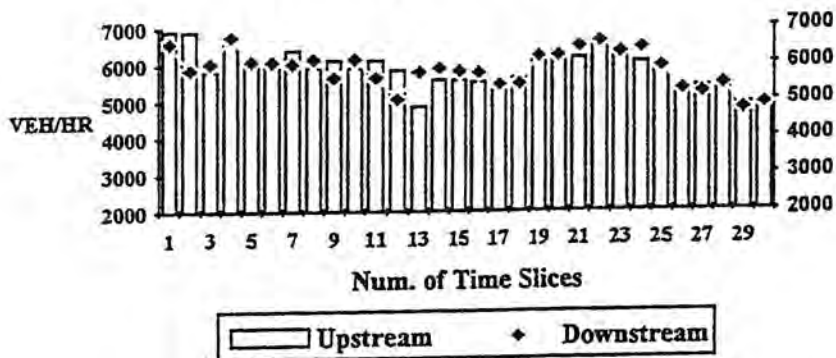

Figure 4-5 Demand pattern on Nov 14, 1989 for 35WPIPE case

Boundary Flow Conditions

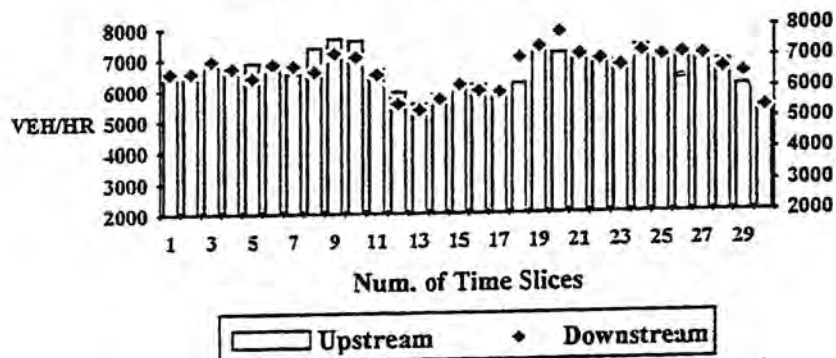
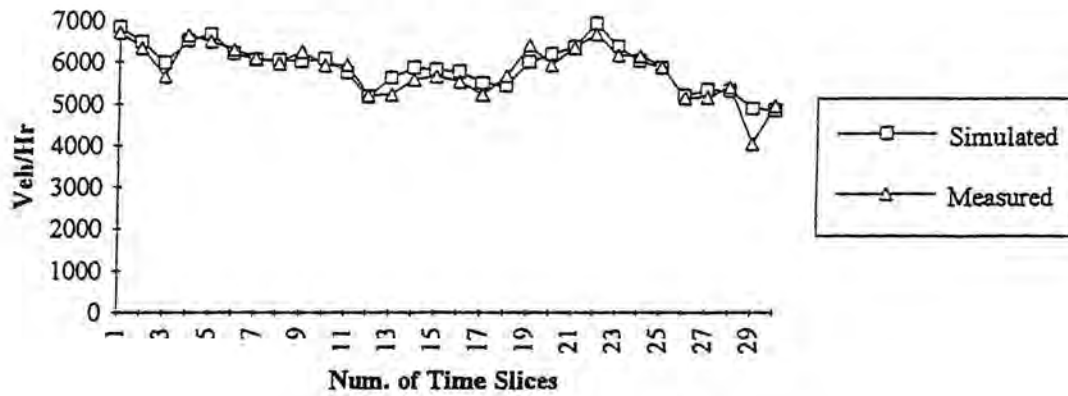

Figure 4-6 Demand pattern on Nov 20, 1989 for 35WPIPE case

Nov. 14, 1989, Detector 28S



MAE = 16.6 veh/hr

MPD = 1.61%

Figure 4-7 Comparison between simulation and real data on Nov. 14, 1989

Nov. 20, 1989, Detector 28S

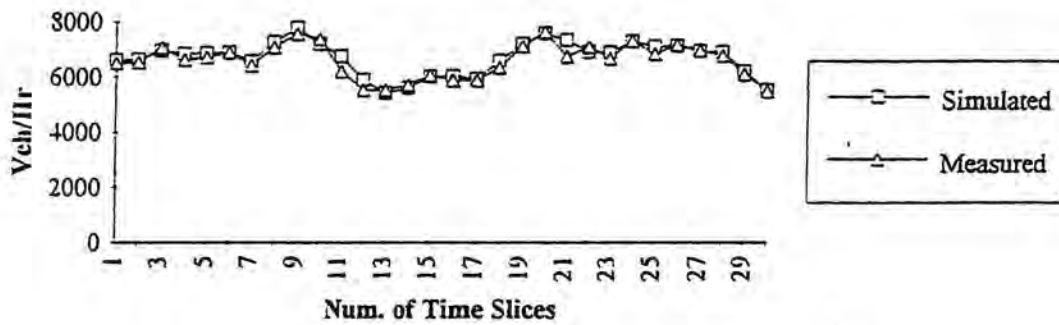

MAE = 13.1 veh/hr

MPD = 1.43%

Figure 4-8 Comparison between simulation and real data on Nov. 20, 1989

- Case 2: 494W case

This case represents a 20-mile-long freeway section: I-494 westbound from Nicollet Avenue to Minnetonka Blvd (see Figure 3-5 for reference). The traffic data was collected by Traffic Management Center from 4:45 a.m. to 11:45 a.m., including morning peak hour from 7:00 a.m. to 9:00 a.m., on May 25, 1993. A very small congestion area from station 182 to station 119 was detected from 7:30 a.m. to 8:30 a.m. The simulation uses 15-minute volume data, speed data is not available at the time of testing. In order to evaluate the performance of the new models, the mean percentage difference between measured volumes and simulated volumes are shown in Table 4-1. Figure 4-9 shows the comparison between simulation results and real data from stations 186. The volume estimation error ranges from 0.7% (zone 1) to 16.7% (zone 60). On a zone-by-zone basis, there is only one zone where the percentage error exceeded 15% percent, while the rest of the percentage errors are lower than 15%. The overall MPD is 8.2%.

- Case 3: 35WN case

This case simulates I-35w northbound from 86th street to 28th street on November 7, 1989. The freeway section has a total length of 8.14 miles with 12 entrance and 10 exit ramps (see Figure 3-6 for reference). The simulation uses 5-minute data starting from 6:00 a.m. to 9:00 a.m. The data contained both the transition from free-flow into congestion and from congestion back into a free-flow condition. Based on the occupancy data, serious congestion was detected from station 63n to 53n from 7:00 a.m. to 8:00 a.m.

Table 4-1 Field vs. simulated results for 494W case

Zone Number	Detector Number	Volume		Zone Number	Detector Number	Volume	
		MAE	MPD			MAE	MPD
1	182	34.7	0.7	31	483	157.0	12.6
4	183	130.8	3.5	41	486	133.4	10.6
8	119	192.1	4.9	43	487	132.6	12.7
11	185	186.9	4.2	45	488	142.4	11.2
13	186	164.7	3.3	46	511	136.2	11.6
17	187	251.7	10.8	48	512	133.4	10.6
19	188	229.2	6.3	52	513	134.0	7.9
22	189	194.6	7.2	54	514	127.6	8.7
24	190	177.1	7.0	56	515	132.8	7.9
25	191	188.9	8.3	56	516	121.9	7.0
25	480	174.5	6.8	58	517	126.0	10.6
25	481	189.7	7.5	60	518	190.8	16.7
27	482	169.0	10.5				

Total number of data points: 567 Overall MAE = 158.6 veh/hr Overall MPD = 8.2%

where,

Mean Absolute Error (MAE):
$$\frac{\sum |Measured - Estimated|_k}{N}$$

Percentage Difference (PD: 100%):
$$\frac{(Measured - Estimated)_k}{Measured_k} \cdot 100\%$$

Mean Percentage Difference (MPD: 100%):
$$\frac{\sum \frac{|Measured - Estimated|_k}{Measured_k} \cdot 100\%}{N}$$

MAY 25, 1993 Detector 186

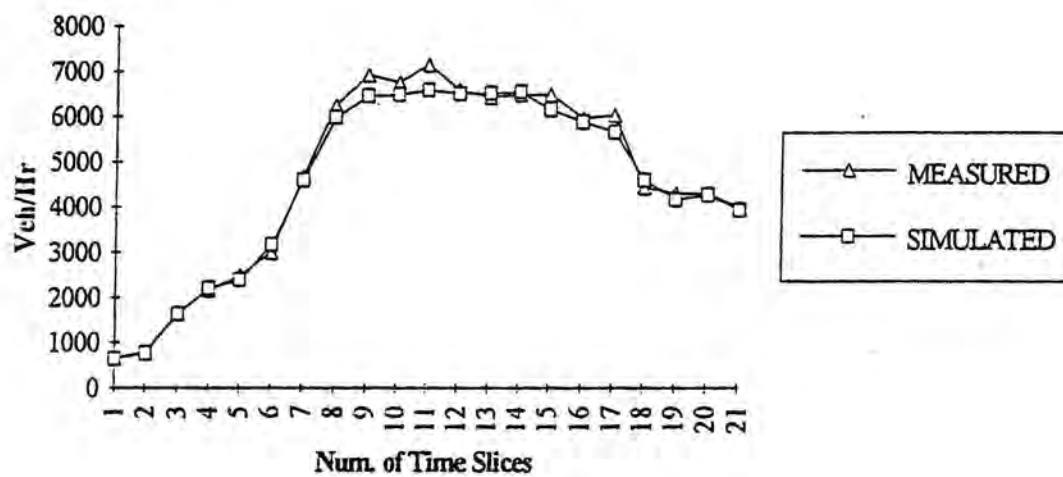

MAE = 164.7 veh/hr

MPD = 3.3%

Figure 4-9 Comparison between simulation and real data for detector 186 (I494W)

To evaluate the model's accuracy in comparison with field observation, the mean percentage differences for both volume and speed are calculated and shown in Table 4-2. Figures 4-10 and 4-11 show the comparison between simulation and observed data for both volume and speed from station 53N. From Table 4-2, the percentage difference for volume ranges from 0.3% (zone 1) to 14.4% (zone 20). There are two zones with difference greater than 10%, and 62.5% of all the differences are lower than 5%. For speed, the percentage difference ranges from 3.1% (zone 4) to 46.0% (zone 8). On a zone-by-zone basis, three zones exhibited percentage greater than 20%. The overall mean percentage difference for volume estimation is 5.4% and 12.5% in speed.

Table 4-2 Field vs. simulated results for 35WN case

Zone Number	Detector Number	Volume		Speed	
		MAE	MPD	MAE	MPD
1	86n	6.4	0.3	2.7	5.5
4	82n	37.1	2.0	1.6	3.1
6	78n	120.4	7.3	3.3	7.1
10	76n	64.8	4.6	1.9	3.6
12	70n	51.4	3.2	NA	NA
12	73n	56.8	3.9	2.5	4.6
14	66n	69.6	4.9	3.2	6.0
18	63n	164.2	11.3	12.9	46.0
20	62n	256.2	14.4	NA	NA
24	61n	79.9	3.8	2.1	4.0
25	60n	63.1	3.7	2.3	4.8
27	55n	66.9	3.3	14.4	26.2
28	53n	178.5	9.2	7.0	15.4
32	46n	93.6	5.1	8.3	14.8
34	42n	71.8	4.5	8.0	13.5
36	35n	81.3	5.5	9.4	21.2

Overall MPD (Volume) = 5.4%

Overall MPD (Speed) = 12.5%

Nov. 7, 1989, Detector 53N Volume

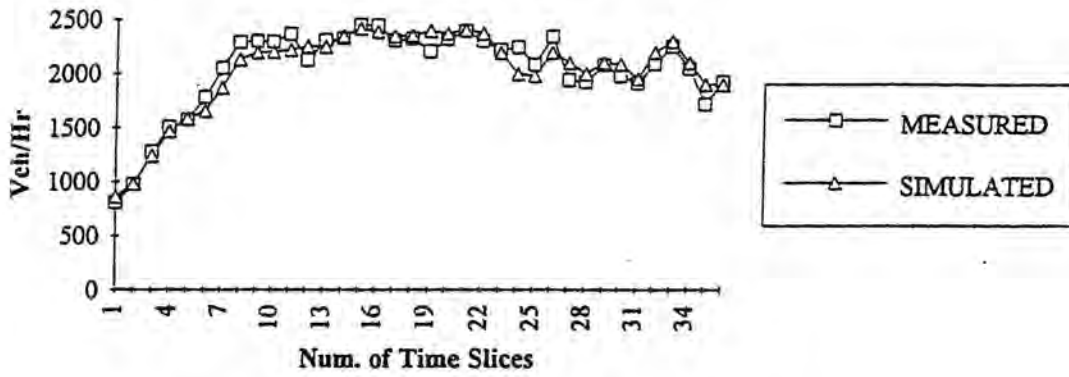

MAE = 178.5 veh/hr

MPD = 9.2%

Figure 4-10 Comparison between simulation and real volume data for detector 53N

Nov. 7, 1989, Detector 53N Speed

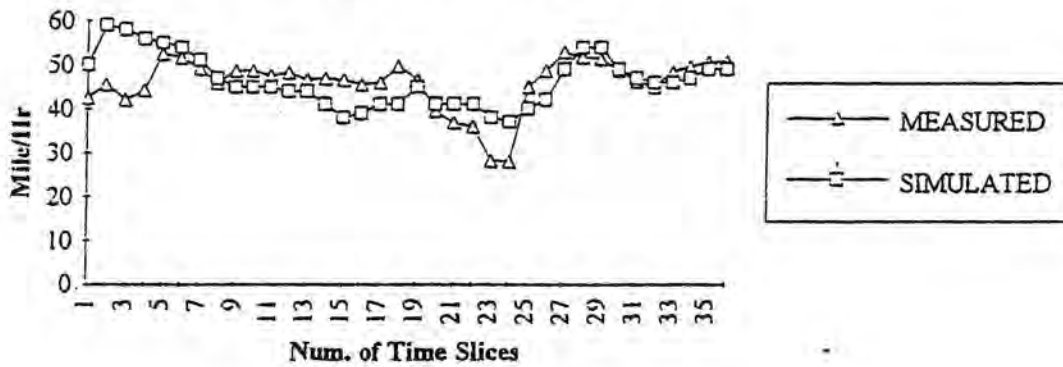

MAE = 7.0 mile/hr

MPD = 15.4%

Figure 4-11 Comparison between simulation and real speed data for detector 53N

- Case 4: 35W62E case

This case involves merging/diverging of two freeways with a common section: interstate freeway 35W northbound and highway 62 eastbound merge, then diverge in the Cross-town area. Due to the problems in the detectors on the merging section, only diverging section is simulated here (see Figure 3-7 for reference). The data was collected on a 5-minute basis starting from 6:00 p.m. to 7:00 p.m. on December 16, 1993. In order to evaluate the performance of the new module, the percentage differences between measured volumes and simulated volumes at station number 322 were calculated and shown in Table 4-3. The error ranges from 0.45% to 4.6. Figure 4-12 shows the observed data and the simulation results.

Table 4-3 Field data vs. Simulated Results For 35W62E case

Time	Volume			Time	Volume		
	Measured	Simulated	Error(%)		Measured	Simulated	Error(%)
7:00	2916	2916	0.0	7:35	2688	2675	0.48
7:05	2136	2148	-0.5	7:40	2568	2592	-0.9
7:10	2172	2160	0.5	7:45	2436	2340	3.9
7:15	2604	2483	4.6	7:50	2568	2627	-2.2
7:20	2028	2076	-2.3	7:55	2352	2256	4.1
7:25	2436	2447	-0.4	8:00	2052	2124	-3.5
7:30	2364	2315	2.0				

$$\text{Error} = (\text{Measured} - \text{Simulated}) / \text{Measured} * 100\%$$

$$\text{MAE} = 51.3 \text{ veh/hr}$$

$$\text{MPD} = 1.95\%$$

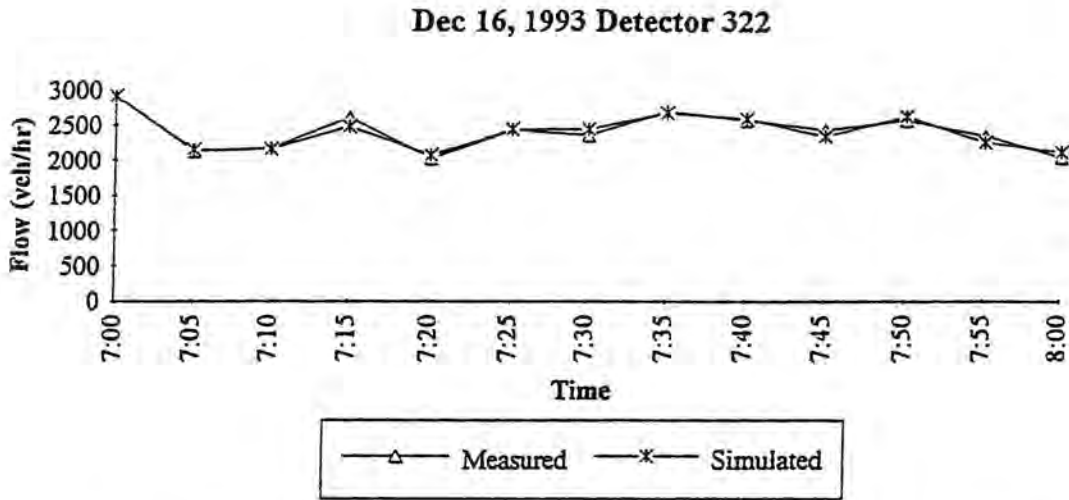

Figure 4-12 Comparison between simulation and real data for 35W62E case

IV.4 Summary

This chapter summarized the test results of the enhanced KRONOS using the procedure and test cases developed in Chapter III. The test results with both hypothetical and real cases indicate good and consistent performance of KRONOS in various situations. The testing procedure and test cases developed in Chapter III should be considered as a first step towards the development a comprehensive guideline for the testing and validation of traffic models. New test cases with real data need to be developed in the future to reflect various real traffic conditions as much as possible.

1
2
3
4
5
6
7
8
9
10
11
12
13
14
15
16
17
18
19
20
21
22
23
24
25
26
27
28
29
30
31
32
33
34
35
36
37
38
39
40
41
42
43
44
45
46
47
48
49
50
51
52
53
54
55
56
57
58
59
60
61
62
63
64
65
66
67
68
69
70
71
72
73
74
75
76
77
78
79
80
81
82
83
84
85
86
87
88
89
90
91
92
93
94
95
96
97
98
99
100

V. CONCLUSION AND FURTHER RESEARCH NEEDS

This report summarized the final results of the current project, which is the Phase II of the KRONOS enhancements effort. First, a procedure and test cases were developed for systematic testing and manual calibration of the simulation parameters. Both hypothetical and real traffic data were used to develop the test cases that could be used for future testing and comparison of model performance. The major enhancements in the simulation module include the incorporation of the new traffic models that can treat two freeways merging/diverging with a common section and the special weaving segment with two auxiliary lanes. Further, the incident module was enhanced to reflect time-variant capacity changes in the incident zone. Traffic diversion at exit ramps when there is a severe congestion at the location downstream from an exit ramp can now be simulated with the enhanced KRONOS. The user interface has also been substantially improved and has the mouse-driven, pop-up menu screen structure. The new interface allows user to input data for main, merging and diverging freeway sections and analyze the output of each section with 2-/3-D graphics. Finally, a dynamic memory allocation module was developed with the declarations of the data structure in the simulation module, which enables KRONOS to utilize the available memory in a computer. While a temporary window-version for the simulation module that uses the memory manager of the Windows and the dynamic memory allocation scheme, it is recognized that the source code of the simulation module needs to be reorganized to take full advantage of the dynamic memory management. Further, the current DOS-based input/output modules also need to be converted to Windows applications, so that an input data file with a long freeway section can be handled without memory limitations.

Future work to enhance KRONOS as a freeway operational tool includes the automatic download of detector data into an input file, automatic calibration of simulation parameters with real data, modeling of HOV lanes and reorganization of the source code to efficiently handle a freeway section longer than 20 miles.

1
2
3
4
5
6
7
8
9
10
11
12
13
14
15
16
17
18
19
20
21
22
23
24
25
26
27
28
29
30
31
32
33
34
35
36
37
38
39
40
41
42
43
44
45
46
47
48
49
50
51
52
53
54
55
56
57
58
59
60
61
62
63
64
65
66
67
68
69
70
71
72
73
74
75
76
77
78
79
80
81
82
83
84
85
86
87
88
89
90
91
92
93
94
95
96
97
98
99
100

BIBLIOGRAPHY

Kwon, E. and Michalopoulos, P.G., et. al. Development of integrated simulation package for freeway design, operations and adaptive traffic management. Final Report for Center for Transportation Studies, University of Minnesota, 1992.

May, Adolf. Traffic flow fundamentals, Prentice Hall (1990)

Michalopoulos, Panos and Kwon, Eil et. al. Enhancements of the KRONOS simulation package for geometric design, planning, operations and traffic management in freeway networks/corridors, Phase I, Final Report prepared for Minnesota Department of Transportation, University of Minnesota, March 1993.

Michalopoulos, Panos and Kwon, Eil and Kang, J. Enhancements and field testing of a dynamic freeway simulation program. Transportation Research Record 1320, National Research Council, pp. 203-215, 1991.

Lax, P. Weak solution of non-linear hyperbolic equation and their numerical computations, Comm. Pure. Appl. Math. 7, pp. 159-193, 1954.

Payne, H. FREFLO: A macroscopic simulation model of freeway traffic. Transportation Research Record, 772, pp. 68-75, 1979.



APPENDIX A

SOURCE CODE FOR DYNAMIC MEMORY ALLOCATION MODULE



APPENDIX A

SOURCE CODE FOR DYNAMIC MEMORY ALLOCATION MODULE

Code and Data Structures Modified For Dynamic Memory Allocation

I. Method of Dynamic Memory Allocation

Most of the data structures used in kronos consist of one, two, and three dimensional static arrays. (A listing of the data structures modified is included is given at the end.) The dynamic memory allocation was implemented by defining the static arrays variables as pointers to dynamically allocated blocks of memory of the appropriate type. Multi dimensional arrays are declared as pointers to pointers. The three cases of transformation to dynamic memory allocation for 1-3 dimensional arrays are illustrated below:

CASE 1 A one dimensional array previously defined as:

```
float ncrar [MXRMP]; /* no of cars arrived at each ramp during each dt */ is declared as a pointer (to an array of floats):
```

```
float *ncrar;
```

and allocated dynamically during initialization as

```
ncrar = (float *)malloc(gMXRMP * sizeof(float))
```

The value of gMXRMP is provided from the KRONOS.mem config file written by the input module.

CASE 2 A two dimensional array previously defined as:

```
float gr [MXRMP][MXRS+1]; /* generation term at merging segments */ is defined as a pointer to pointer to a float:
```

```
float **gr;
```

and allocated dynamically during initialization as:

```
if ( (gr = (void *)malloc(gMXRMP * sizeof(float *))) == 0 ) return(0);
for(i=0;i<gMXRMP;i++) {
    if ( (gr[i] = (void *)malloc( (MXRS+1) * sizeof(float)) ) == 0 ) return(0); } }
```

CASE 3 A three dimensional static array previously defined as:

```
float rd [2][MXRMP][MXRS+1], /* density on each dx for 2 dt on entrance */ is declared as:
```

```
***float rd;
```

and allocated dynamically during initialization as

```
if ( (rd = (void *)malloc(2 * sizeof(float **))) == 0 ) return(0);
for(i=0;i<2;i++) {
    if ( (rd[i] = (void *)malloc(MXRS * sizeof(float *))) == 0 ) return(0);
    for(j=0;j<gMXRMP;j++) {
        if ( (rd[i][j] = (float *)malloc((MXRS+1) * sizeof(float))) == 0 )
            return(0); } } }
```

Program Flow: Dynamic Memory allocation is performed prior to initialization of the data structures. If there is insufficient memory the programs reportys the error and exits. A call graph of the memory allocation functions is shown below:

Memory Allocation Call Graph

main

```
|_allocate_memory_for_globals
|_read_memory_config_file
|_fopen?
|_printf[2]?
|_fscanf[5]?
|_fclose?
|_allocate_memory_for_ramps
|_malloc[111]?
```

```

|_calloc[4]?
|_allocate_memory_for_sections
|_malloc[22]?
|_allocate_memory_for_zones
|_malloc[4]?
|_calloc[34]?
|_allocate_memory_for_qkcurves
|_malloc[8]?
|_allocate_memory_for_other
|_calloc[43]?
|_init_consts()
|_prezero()
|_open_inf()
|_...

```

2. Global Data Structures Modified for Dynamic Memory Allocation

```

QKCURVE **qkcurves,
**lad_qkcurves,
*rmp_qkcurves,
**inc_qkcurves,
*cd_qkcurves;

/* the real inc_qkcurves 2*MXICTRN+2 */
float /* dimensions = [2][MXRMP][MXRS+1] */
***rd,
***ru,
***rx,
***rxu,
***rwd,
***rwu,
/* dimensions = [MXRMP][MXRS+1] */
**gr,
**gx,
**gw,
**ard,
**aru,
**arq,
**arxd,
**arxu,
**arxq,
**arwd,
**arwu,
**arwq,
/* dimensions = [MXRMP] */
*ncrar,
*ncrde,
*ncin,
*ncout,
*mqs,
*mqlr,
*mqsx,
*mqlx,
*aqs,
*aqlr,

```



```

*aqsx,
*aqlx,
*semi_two_out,
    /* dimensions = [MXLN+1][MXSC+1] */
**g,
**akd,
**aus,
**aq,
    /* dimensions = [MXLN+1][2][MXSC+1] */
***kd,
***us,
    /* dimensions = [2][MXSC+1] */
**tkd1,
**tus1,
**tkd2,
**tus2,

*min_euler_flow1, /* [MXLAD+1], */
*min_euler_flow2, /* [MXINC], */

char    **zon_nam,          /* [MXZN][TEXT_LEN] */
        **zon_name;       /* [MXZN][TEXT_LEN] */

int     /* mainline freeway geometrics specific data items */
cd_off,
nzns;  /* no. of zones on freeway */
nmz,   /* no of merging zones */
ndz,   /* no of diverging zones */
nwz,   /* no of weaving zones */
nsc,   /* total no of dx sections on freeway proper */
nlns,  /* max no of lanes */

*lane,      /* no of lanes on mainline for each zone */
*zlength,  /* length of each zone in feet */
*zbgm,     /* (cumulative) no. of 1st dx of each zone */
*zend,     /* (cumulative) no. of last dx of each zone */
*ztyp,     /* type of zone, 1..16; refer manual *** */
*zlensec1,
*zlensec2,
*zsec1,
*zsec2,

    /* ramp geometrics specific data */
    /* dimensions = [MXRMP] */

*rlane,
*onlane,
*lenon,
*lenoff,
*lendec,
*mloc,
*nr,
*nx,
*nma,
*nda,

```

*nwa,

/* lad zone specific geometric data */

strz, / [MXLAD], start of transition in lad segments; cum feet */
ltrz, / [MXLAD], length of transition in lad segments; cum feet */
nbtz, / [MXLAD], (cum) dx at which transition begins */
netz, / [MXLAD], (cum) dx at which transition ends */

/* incident zone specific geometric data */

inln, / [MXINC] no of lanes blocked during an incident */
sinc, / [MXINC] start of incident; cum in feet */
linc, / [MXINC] length of incident; cum in feet */
nbbn, / [MXINC] (cum) dx at which incident begins */
nebn, / [MXINC] (cum) dx at which incident ends */
ibgn, / [MXINC] starting time in cum minutes of incident */
iend, / [MXINC] end time in cum minutes of incident */
capa, / [MXINC] */
rend, / [MXINC] */
step, / [MXINC] */
stepime, / [MXINC] */

/* cd road geometrics specific data */

cd1, / [MXCD], cum dx at which each sub section of cdroad begins */
cd2, / [MXCD] */
cd3, / [MXCD] */
cd4, / [MXCD] */
cd5, / [MXCD] */
cd6, / [MXCD] */
cd7, / [MXCD] */
cd8, / [MXCD] */
cdl1, / [MXCD], length of each sub section of cdroad */
cdl2, / [MXCD] */
cdl3, / [MXCD] */
cdl4, / [MXCD] */
cdl5, / [MXCD] */
cdl6, / [MXCD] */
cdl7, / [MXCD] */
cdl8, / [MXCD] */
cdl9; / [MXCD] */

float

usk, / [MXUSUK], user specified density values for uk curve */
usu, / [MXUSUK], user specified speed values for uk curve */
kuslop, / [MXUSUK-1], slope of uk curve */
kuslop2, / [MXUSUK-1], 2 * slope of uk curve */
kuslop4, / [MXUSUK-1], 4 * slope of uk curve */

/* volumes and capacities: mainline and ramps */

*zoneq,
*zoneq1,
*zoneq2,
*cap,
*volume,

```

/* dimensions = [MXRMP] */
*capon,
*qon,
*mrates,
*qrem,
*capoff,
*qoff,
*qx,
*q_th,
*capwv,
*qwv,
*asfcg,
*dvp,
*lxq,

*cap2, /* [MXLAD], */
*capi, /* [MXINC], */
*capcd, /* [MXCD], */
*qcd, /* [MXCD], */

/* cumulative and intermediate moes and emissions */
/* for mainline freeway */
*tt, /* [MXZN], inter total travel, vehmiles,for each time slice */
*ttti, /* [MXZN], inter total travel time,vehmins,for each time slice */
*tttu, /* [MXZN], inter average speed, mph, for each time slice */
*att, /* [MXZN], cum total travel, veh-miles, for each time slice */
*attti, /* [MXZN], cum total travel time,vehmins, for each time slice */
*atttu, /* [MXZN], cum average speed, mph, for each time slice */
*delay, /* [MXZN], inter delay, mins */
*fuel, /* [MXZN], inter fuel consumed */
*hc, /* [MXZN], inter hc emissions */
*co, /* [MXZN], inter co emissionc */
*nox, /* [MXZN], inter nox emissions */
*adelay, /* [MXZN], cum delay, mins */
*afuel, /* [MXZN], cum fuel consumed */
*ahc, /* [MXZN], cum hc emissions */
*aco, /* [MXZN], cum co emissionc */
*anox, /* [MXZN], cum nox emissions */

/* for all entrance ramps */
/* dimensions = [MXRMP] */
*rtt,
*rtti,
*rttu,
*ratt,
*rattti,
*ratttu,
*rdelay,
*rfuel,
*rhc,
*rco,
*rnox,
*radelay,
*rafuel,

```

*rahc,
*raco,
*ranox ,

/* for all exit ramps */

*xtt,
*xtti,
*xttu,
*xatt ,
*xatti,
*xatttu,
*xdelay,
*xfuel,
*xhc,
*xco,
*xnox ,
*xadelay,
*xafuel,
*xahc,
*xaco,
*xanax ;

BOOLEAN

inc, / [MXZN], if there is an incident in the zone */
initc, / [MXZN], if initial congestion is considered */
*initc1,
*initc2,
mtr, / mtr [MXRMP], if entrance ramp is metered */
mcng, / mcng[MXRMP], if metering causes spillback on onramp */
dr, / dr [MXRMP], if there is capacity restriction at each ramp */
*qoffc;

□

APPENDIX B

ALTERNATIVE OBJECT-ORIENTED PROGRAMMING FRAMEWORK FOR FUTURE KRONOS



APPENDIX B

ALTERNATIVE OBJECT-ORIENTED PROGRAMMING FRAMEWORK FOR FUTURE KRONOS

```
//
//          Globals.h : Basic object definition for freeway
//

#ifndef globals.h
#define globals.h

#include <fstream.h>
#include "datadef.h"

class Freeway ;
class Segment ;
class Incident_detail ;

class QK_CURVE {
private :
    int density[MAX_QK_POINT] ;
    int flow[MAX_QK_POINT] ;
public :
    QK_CURVE(){} ;
    // define the function here related to get the value
    // from QK curve. Don't make the separate function.
};

struct Fraction{
    float psg_v ; // passenger car
    float lght_cm_v ; // light commercial vehicle
    float hvy_cm_v ; // fraction of heavy commercial vehicle
};

//
// Output option : T/F flag
//
struct Out_Op{
    int inst_dst, inst_spd, inst_flow ;
    int avg_dst, avg_spd, avg_flow ;
};

//
//input file.
//
class Input_Data{
private :
    int ver ; // private data
    char Desc[MAX_DESC] ; // version of data file
    char simul_data[MAX_DESC] ; // files description
    // date of simulation
};
```

```

int delta_x ;
int sim_time ; // simulation time
int dur_time_slice ; // length of time slice
int num_time_slice ; // number of time slice
int init_option ; // initialization option
int min_spd ; // minimum speed
int jam_dst ; // jam density
int simul_incident ; // TRUE or FALSE
Fraction frac;
QK_CURVE qk_curve ;
int num_mrg_frwy ;
int num_dvg_frwy ;
ifstream MRG[MAX_MRG_FRWY] ;
ifstream DVG[MAX_DVG_FRWY] ;
ifstream BLT[MAX_BLT_FRWY] ;
Freeway *main_frwy ;
Freeway *mrg_frwy[MAX_MRG_FRWY] ;
Freeway *dvg_frwy[MAX_DVG_FRWY] ;
Freeway *blt_frwy[MAX_BLT_FRWY] ;
public :
Input_data() ; // initialize the private field before
// execute the next step
read_data(){
// read_global data
// read_freeway_data() ; ==> repeat this functio for each freeway
}

// public function
// read data
// simulation
// output
};

//
// Freeway object : same for main/ merging/ diverging
//
class Freeway{
private:
int total_num_seg ; // total number of segment
void *Seg_List ; // array of segment, will be allocated later
int down_demand ; // flag
int up_congest ; // flag
int down_congest ; // flag
int fuel_pol ; // flag
int output_moe ; // flag
char file_name[MAX_DESC] ; // input file name for freeway
char date_of_cr[MAX_DESC] ; // date of creation
Out_Op output_option ; // Output Option ,
// each freeway might have different
// output options

int plot_time ;
int num_time_slice ;
int total_freeway_len ;
int incident ; // Flag : incident analysis?

```



```

public :
    // read data
    // simulation
    // save result
};

//
// Segment class contains the common data for all segment
// This will be inherited to every newly defined segment
// objects
//
// Each segment has its own calculation model and will be
// implemented in public field.
// And, it will be called from the freeway class
//
// For some field, memory has to be allocated depending on the
// number of time slice.
//
class Segment {
protected :
    void *next_Seg ; // pointer to next segment
    int seg_type;    // segment type (refer to segment table)
    char frwy_mark; // 'M' for mrg, 'D' for dvg, and 'B' for belt
                    // and none for NULL
    Freeway *frwy_from_this ;
    float length;   // segment length in ft
    float sec1, sec2, sec3;
    int num_lane;  // num of lanes in this segment
//
// Different from the 8.0 each segment can have 3 different cap.
//
    int cap_init, cap_mid, cap_final;
                    // vph : there will be three different cap.
                    // in segment. They might be the same.
    int init_flow; // flow rate at t0
    int congestion; // if init. condition is under congestion
    int incident;  // incident condition BOOLEAN
    Incident_detail *incd_ptr ;
                    // idx to incident detail if any (NULL else)
    char zone_name[ZONE_NAME_LENGTH];
                    // zone name
    int num_time_slice ;
public :
    // segment initialization function
    // read in data
};

//
// Typical data for on ramps
//
struct On_ramp{

```

```

int capacity;          /* vph */
int init_flow;        /* vph */
int length;           /* ft */
int *arrival;         /* arrival rate (vph) */
int metering;         /* TRUE/FALSE */
int meter_distn;      /* meter distance from beginning of ramp */
int *meter_rate;      /* metering rate (vph) */
};

//
// Typical Data for off ramps
//
struct Off_ramp{
int capacity;
int init_flow;
int init_congest;     /* initial down stream congestion ? */
int length;
int metering;         /* TRUE/FALSE */
int meter_distn;      /* meter distance from beginning of ramp */
int *exit_rate;       /* exit rate from main lane freeway */
int restrict;        /* capacity restriction on exit ramp */
int *rest_cap;        /* restrict capacity at end of ramp */
int *thro_dem;
int *congest;         /* down stream congestion ? */
int *diversion;
};

class Weaving_seg : public Segment{
private :
    On_ramp ramp1;
    Off_ramp ramp2;
    int aux_capacity;
    int init_flow;
    int *en_perct;     /* percent of entrance ramp traffic entering */
                        /* freeway */
public :
    // constructor for initializing each field
    // simulation module to calculate everything
};

//
// Followings are the list of object currently supported by Kronos 9.0
// The programmer can add new type of segment.
//
class New_weaving_seg : public Segment {
private :
    Weaving_seg weaving;
    int aux_length1, aux_length2; //length of aux. lane before and after weaving
    int capacity;          //capacity of first aux. lane
public :
    //
};

```

```

class Ln_add_drop : public Segment {
private :
    float dis_tran;          /* distance to transition section */
    float tran_len;        /* length of transition section */
    int capacity;          /* capacity after transition */
public :
};

class Cd_road_seg : public Segment {
private :
    float length[9];       /* length of section A.. I */
    int capacity;
    int init_flow;
    Off_ramp ramp1;        /* ramp at C */
    Weaving_seg ramp2_3;   /* ramps at E */
    On_ramp ramp4;        /* ramp at G */
    int *exit_rate ; /* exit rate from main lane freeway */
    int *arrival; /* arrival rate to main lane (vph) */
    int *meter_rate; /* metering rate (vph) */
public :
};

class Incident_detail {
private :
    int seg_num;          /* index to segment has incident */
    int lane_block;      /* number of lanes blocked */
    float distance_to;    /* distance from starting of segment to it */
    float length;        /* length affected by incident (ft) */
    int capacity[MAX_INC_STAGE]; /* capacity of freeway along incident */
    int start_time;      /* starting and ending time of incidents */
    int time[MAX_INC_STAGE];
    int stage;
    int recover_time;
public :
    // read in the incident data
    // function for incident calculation
};

#endif

```

```

//          datadef.h : file for constant definitions
//
//

#ifndef datadef.h
#define datadef.h

// max length of file desc.
#define MAX_DESC      80

//
// simulation parameters
//
#define MAX_SIMUL_TIME  6000 // max simulation time
#define MAX_TIME_SLICE  200  // max simulation time slice
#define MAX_QK_POINT   3    // max num. of point in uk curve

//
// Number of Freeway limits
// There is no restriction about changing the number
// of frwy. Just changing the constants will be effective
//
#define MAX_DVG_FRWY   3 // Max num. of mrg frwy
#define MAX_MRG_FRWY   3 // Max num. of dvg. frwy
#define MAX_BLT_FRWY   1 // Max num. of belfway

//
// Max incident simulation stage
//
#define MAX_INC_STAGE  6

/** segment limits */
#define ZONE_NAME_LENGTH 31 // length of zone name */
#define MIN_FW_LENGTH  200 // ft. min can be accepted */
#define MAX_NUM_LANE    8  // max number of lanes in one segment */
#define MAX_LANE_CAP    3000 // max capacity (vph) one lane can have */
#define MIN_LANE_CAP    1  // min for on section */

/** ramp limits */
#define MAX_RAMP_LENGTH 3000 // ft */
#define MIN_RAMP_LENGTH 200  // ft */
#define MIN_RAMP_CAP    100  // vph */
#define MAX_RAMP_CAP    3000 // vph */
#define MAX_WEAVE_LEN   2000 // max weaving segment length */
#define MAX_AUX_LEN     4000 // max length of aux. lane */

/** other segment types */

#define MAX_WEAVING     20 // max weaving section acceptable */
#define MAX_LN_ADD_DROP 10 // max lane add / drop section acceptable */
#define MAX_CD_ROAD     5  // max CD_ROAD acceptable */
#define MAX_INCIDENT    5  // max num of incident segment */
#define MAX_NEW_WEAVING 10 // max two lanes weaving section */

```

```
/****** segment types *****/
```

```
#define STRICT_LN      1    /* strict lane */  
#define RIGHT_ACC_MERGE 2    /* right merging with acceleration lane */  
#define LEFT_ACC_MERGE 5    /* left merging with acc. lane */  
#define RIGHT_MERGE    8    /* right merge with lane add */  
#define LEFT_MERGE     10   /* left ..... */  
#define RH_DEC_DIVER   3    /* right diverging with deceleration lane */  
#define LT_DEC_DIVER   6    /* left ..... */  
#define RH_DIVERGE     9    /* right diverging */  
#define LT_DIVERGE     11   /* left .... */  
#define RH_WEAVE       4    /* right weaving segment */  
#define LT_WEAVE       7    /* left .... */  
#define RH_LANE_DROP   12   /* right most lane drop */  
#define LT_LANE_DROP   13   /* left .... */  
#define RH_LANE_ADD    15   /* right most lane addition */  
#define LT_LANE_ADD    14   /* left .... */  
#define CD_ROAD        16   /* C-D road */  
#define RH_FW_MERGE    17   /* two lanes right entrance freeway */  
#define RH_FW_DIVER    18   /* two lanes right exit freeway */  
#define LT_FW_MERGE    19   /* ..... left entrance freeway */  
#define LT_FW_DIVER    20   /* ..... left exit freeway */  
#define RH_2_MERGE     21   /* two lanes right entrance ramp */  
#define RH_2_DIVER     22   /* two lanes right exit ramp */  
#define LT_2_MERGE     23   /* two lanes left entrance ramp */  
#define LT_2_DIVER     24   /* two lanes left exit ramp */  
#define RH_PIPE        25   /* semi disagg pipe (right most lane separated */  
#define LT_PIPE        26   /* semi disagg pipe (left most lane separated */  
#define NEW_WEAVING    27   /* weaving with second aux. lane */
```

```
#endif
```



APPENDIX C
DATABASE OF TEST CASES



APPENDIX C

DATABASE OF TEST CASES

- ON-RAMP TYPE

1. Simple on-ramp with auxiliary lane section (segment type 2 and 5)

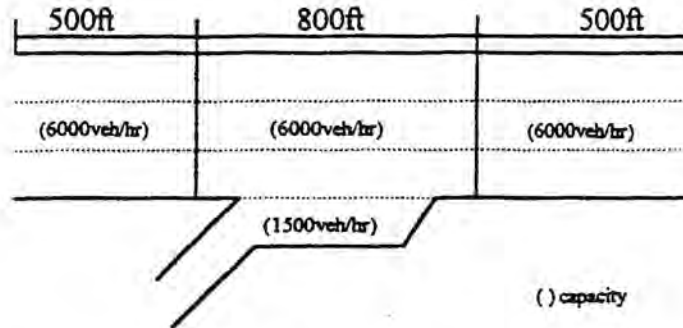

Figure 1 Geometric of simple on-ramp testing section

Case 1: normal uncongested case with file name *merg-r.kr8*

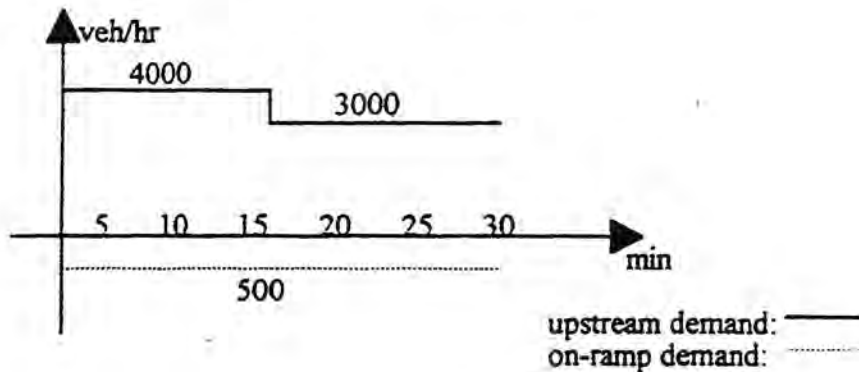

Figure 2 Demand pattern of simple on-ramp test case 1

Case 2: downstream restriction case with file name *merg-d.kr8*

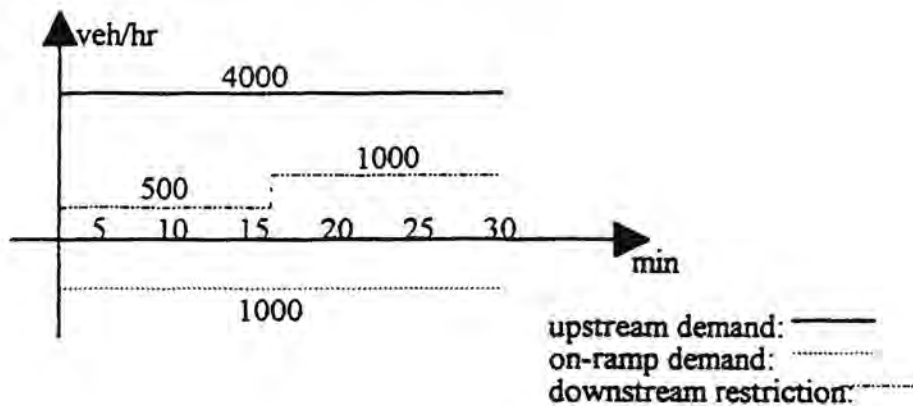

Figure 3 Demand pattern of simple on-ramp test case 2

Case 3: on-ramp metering case with file name *merg-m.kr8*

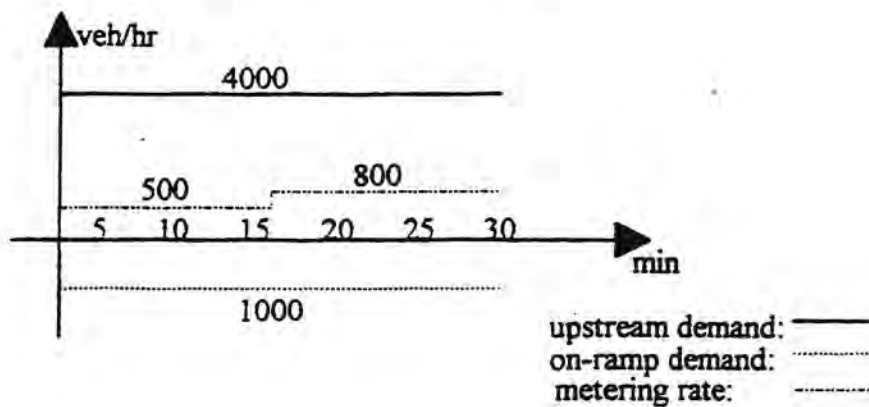

Figure 4 Demand pattern of simple on-ramp test case 3

2. on-ramp with an exclusive lane section (segment type 8 and 10)

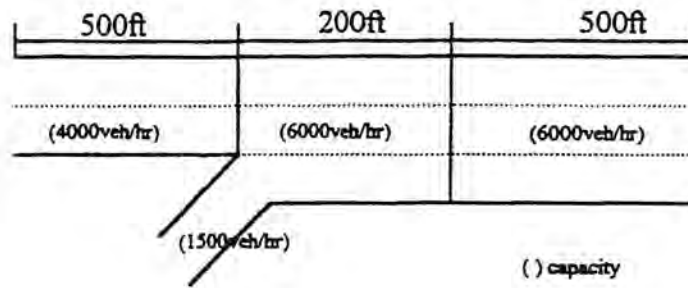

Figure 5 Geometric of on-ramp with an exclusive lane testing section

Case 1: normal uncongested case with file name *e1on-n.kr8*

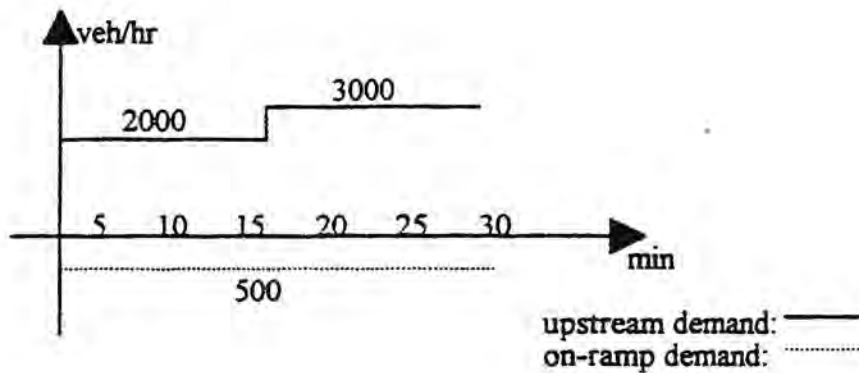

Figure 6 Demand pattern of on-ramp with an exclusive lane test case 1

Case 2: downstream restriction case with file name *e1on-d.kr8*

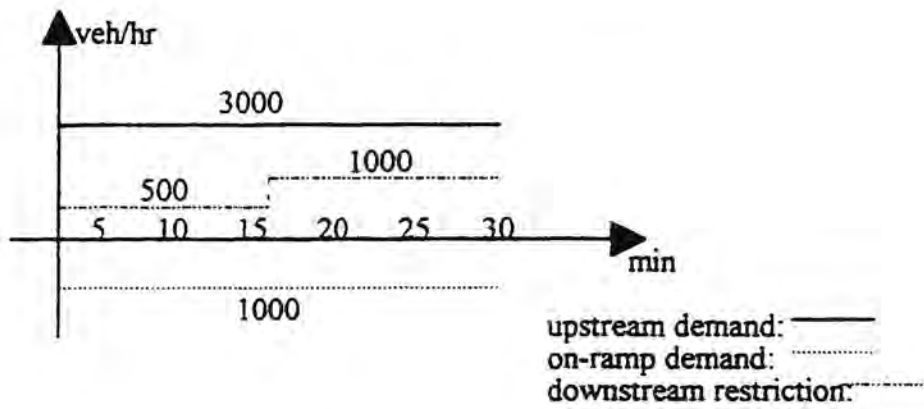

Figure 7 Demand pattern of on-ramp with an exclusive lane test case 2

Case 3: on-ramp metering case with file name *e1on-m.kr8*

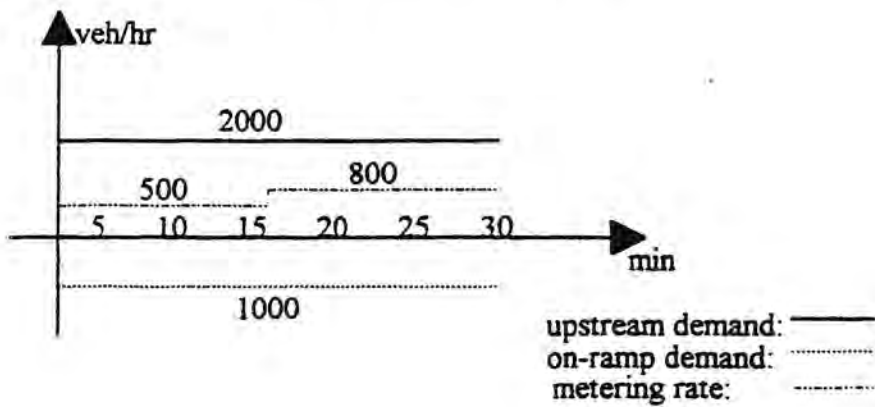

Figure 8 Demand pattern of on-ramp with an exclusive lane test case 3

3. on-ramp with two exclusive lanes section (segment type 17 and 19)

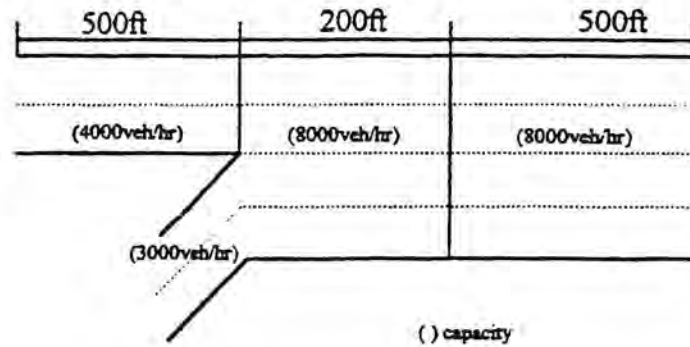

Figure 9 Geometric of on-ramp with two exclusive lanes testing section

Case 1: normal uncongested case with file name *e2on-r.kr8*

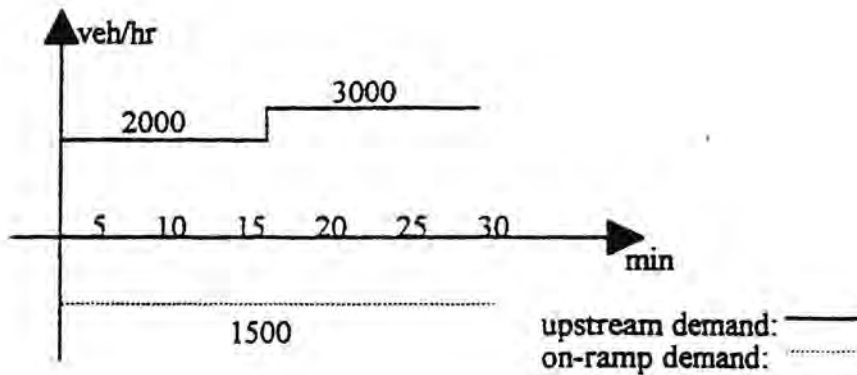

Figure 10 Demand pattern of on-ramp with two exclusive lanes test case 1

Case 2: downstream restriction case with file name *e2on-d.kr8*

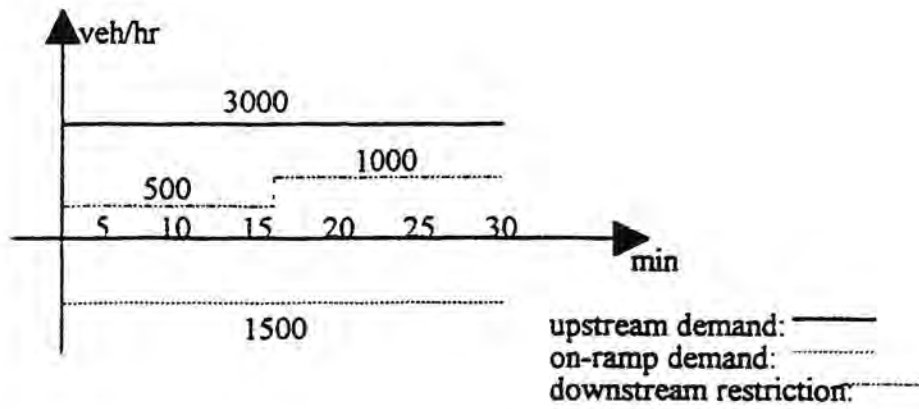

Figure 11 Demand pattern of on-ramp with two exclusive lanes test case 2

Case 3: on-ramp metering case with file name *e2on-m.kr8*

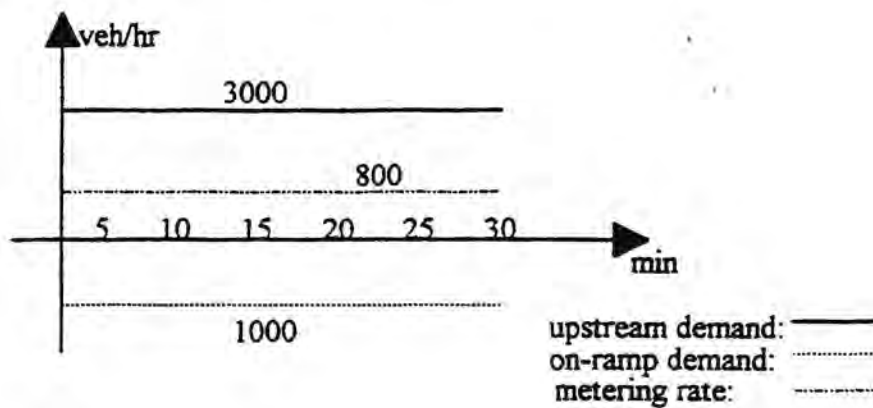

Figure 12 Demand pattern of on-ramp with two exclusive lanes test case 3

4. two-lane on-ramp section (segment type 21 and 23)

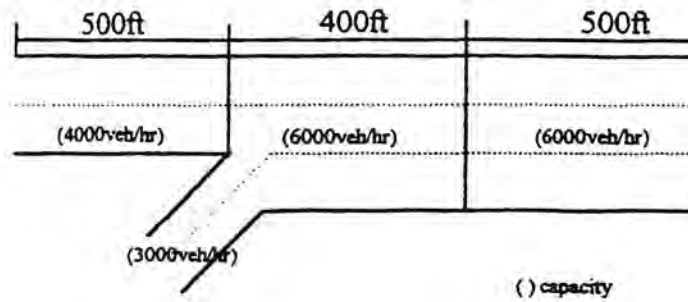

Figure 13 Geometric of two-lane on-ramp testing section

Case 1: normal uncongested case with file name 21on-n.kr8

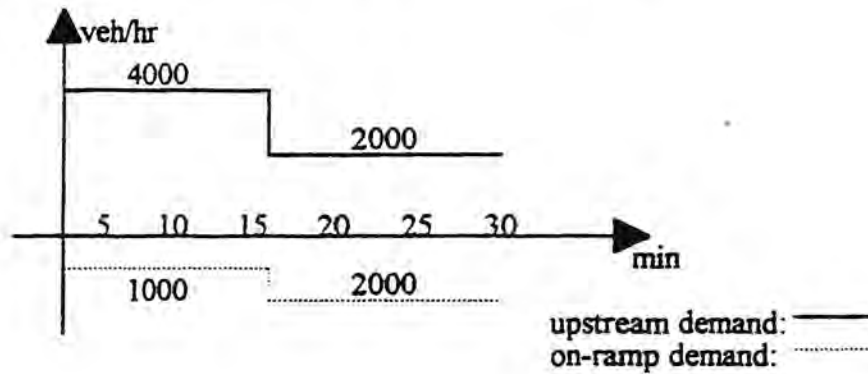

Figure 14 Demand pattern of two-lane on-ramp test case 1

Case 2: downstream restriction case with file name *21on-d.kr8*

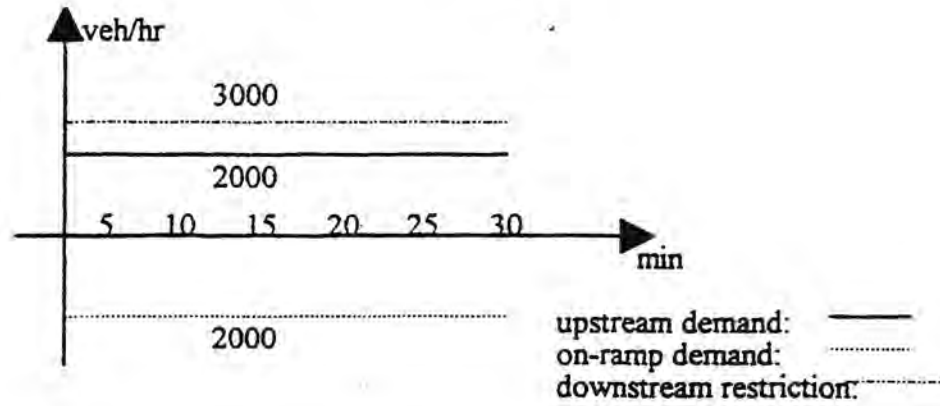

Figure 15 Demand pattern of two-lane on-ramp test case 2

Case 3: on-ramp metering case with file name *21on-m.kr8*

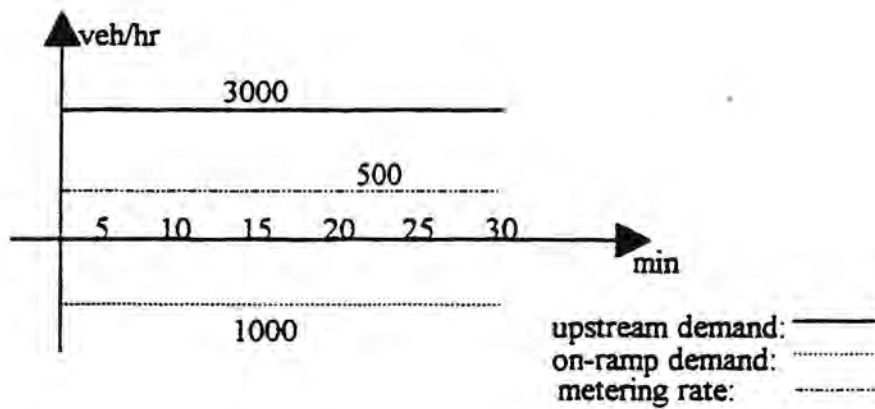

Figure 16 Demand pattern of two-lane on-ramp test case 3

- OFF-RAMP TYPE

1. Simple off-ramp with deceleration lane section (segment type 3 and 6)

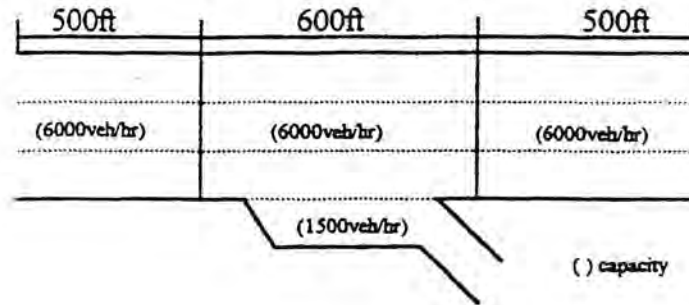

Figure 17 Geometric of simple off-ramp testing section

Case 1: normal uncongested case with file name *divg-n.kr8*

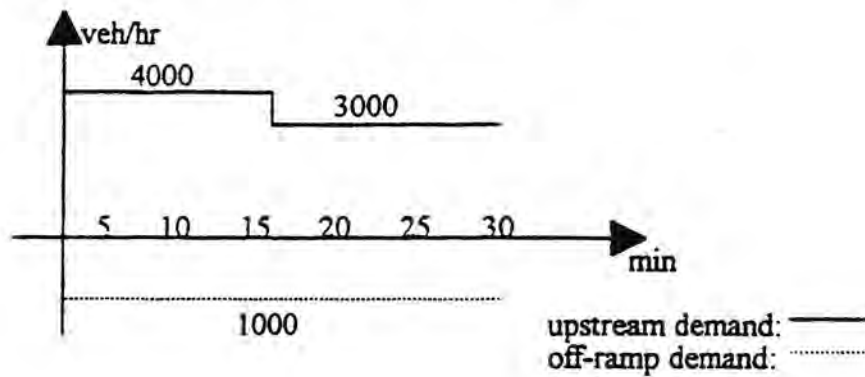

Figure 18 Demand pattern of simple off-ramp test case 1

Case 2: downstream restriction case with file name *divg-d.kr8*

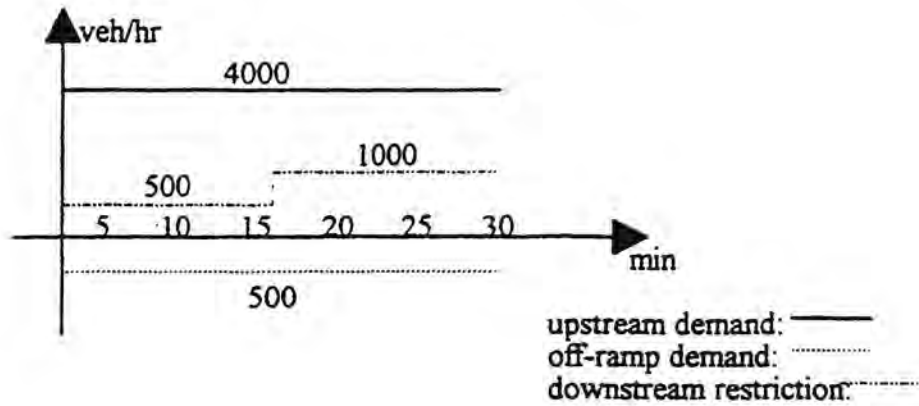

Figure 19 Demand pattern of simple off-ramp test case 2

Case 3: off-ramp capacity restriction case with file name *divg-r.kr8*

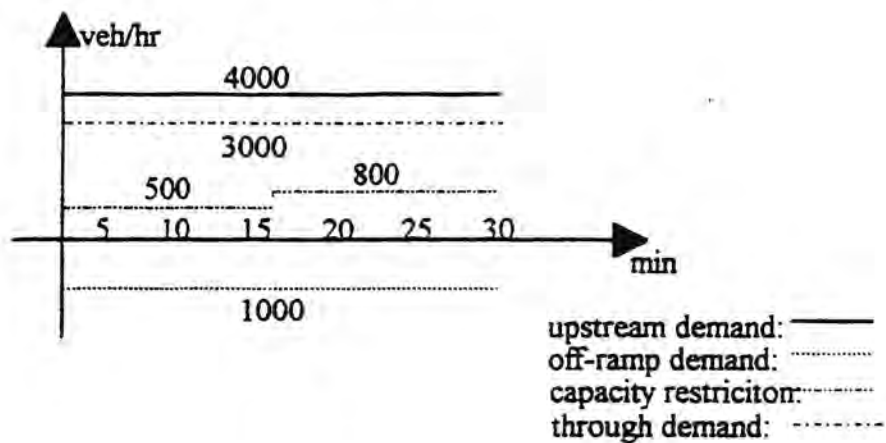

Figure 20 Demand pattern of simple off-ramp test case 3

2. one lane exclusive off-ramp section (segment type 9 and 11)

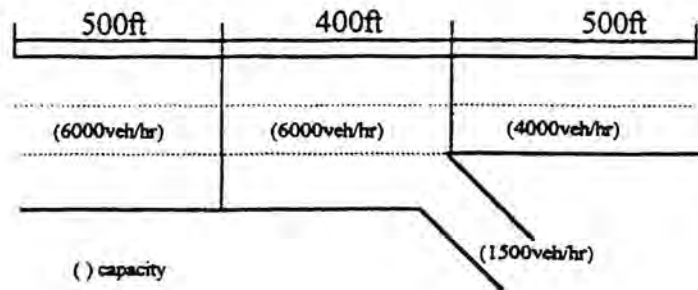

Figure 21 Geometric of one lane exclusive off-ramp testing section

Case 1: normal uncongested case with file name *e1off-n.kr8*

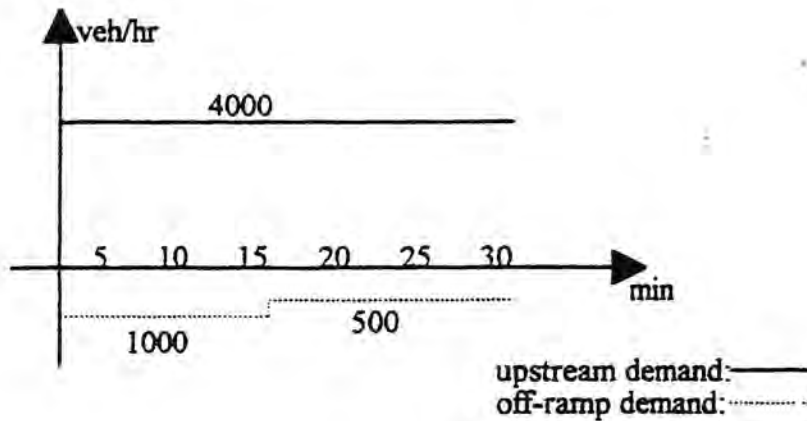

Figure 22 Demand pattern of one lane exclusive off-ramp test case 1

Case 2: downstream restriction case with file name *e1off-d.kr8*

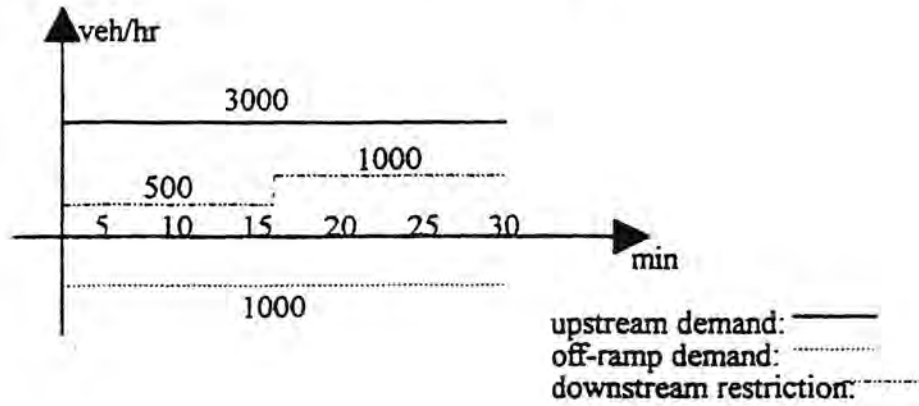

Figure 23 Demand pattern of one lane exclusive off-ramp test case 2

Case 3: off-ramp capacity restriction case with file name *e1off-r.kr8*

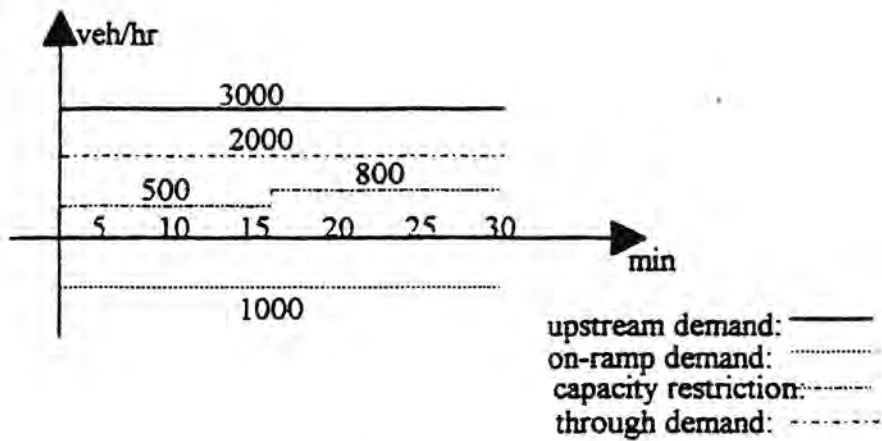

Figure 24 Demand pattern of one lane exclusive off-ramp test case 3

3. two-lane exclusive off-ramp section (segment type 18 and 20)

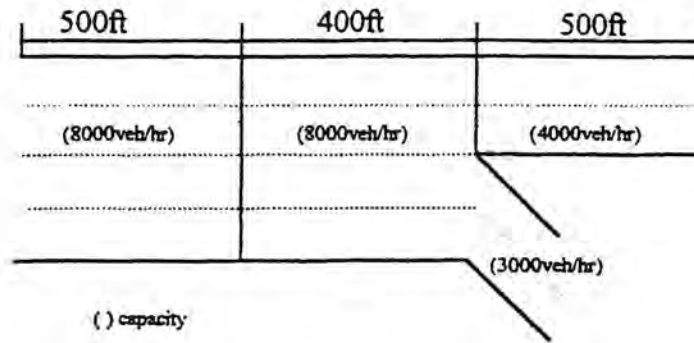

Figure 25 Geometric of two-lane exclusive off-ramp testing section

Case 1: normal uncongested case with file name *e2off-n.kr8*

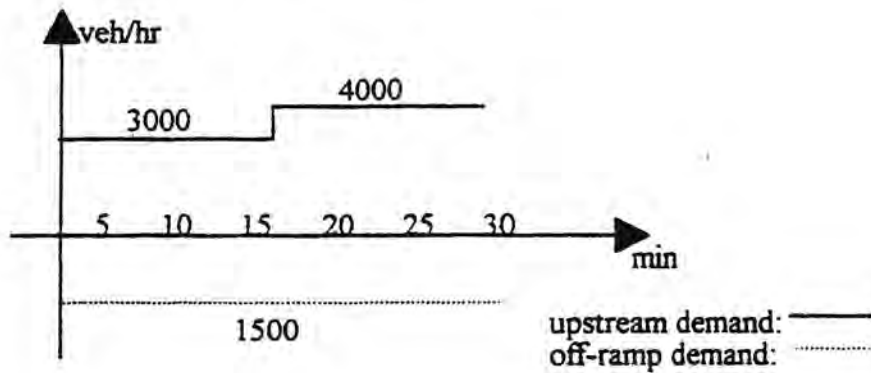

Figure 26 Demand pattern of two-lane exclusive off-ramp test case 1

Case 2: downstream restriction case with file name *e2off-d.kr8*

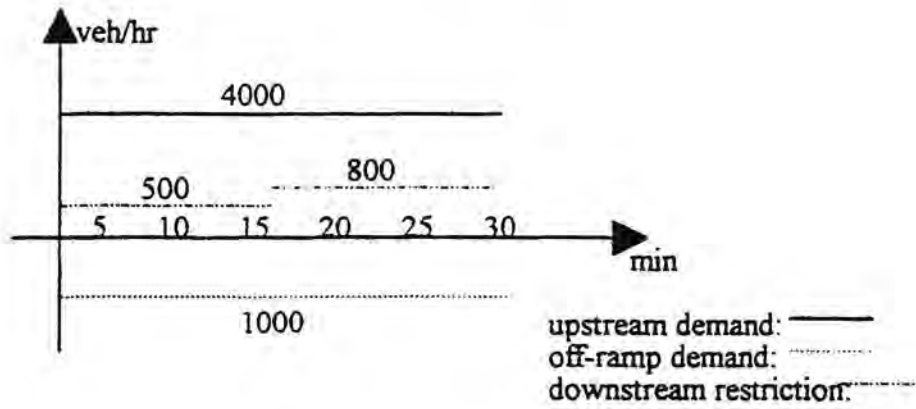

Figure 27 Demand pattern of two-lane exclusive off ramp test case 2

Case 3: capacity restriction case with file name *e2off-r.kr8*

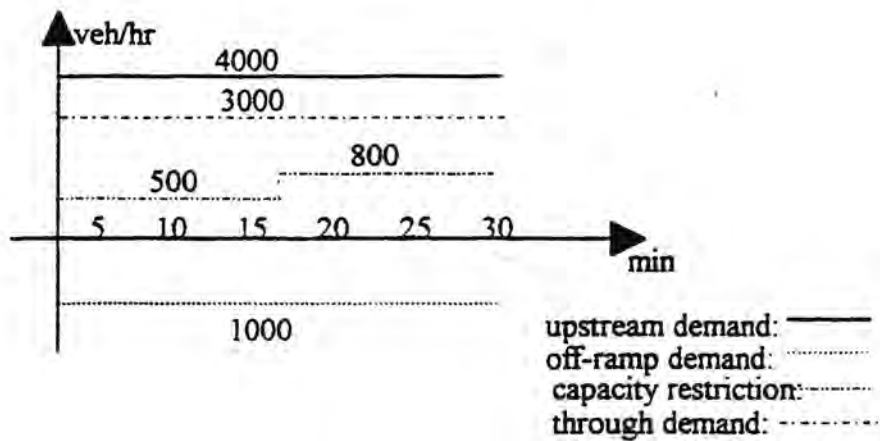

Figure 28 Demand pattern of two-lane exclusive off-ramp test case 3

4. two-lane off-ramp section (segment type 22 and 24)

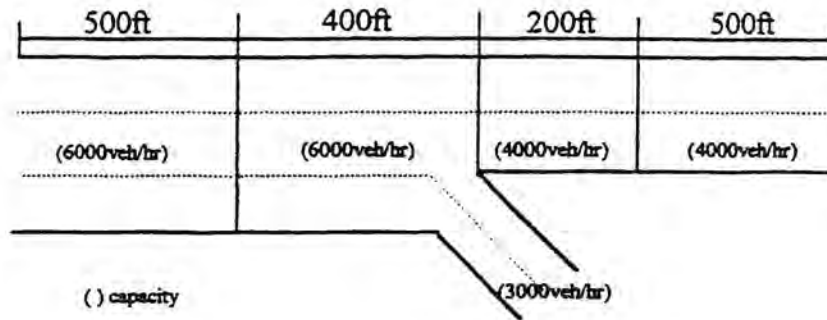

Figure 29 Geometric of two-lane off-ramp testing section

Case 1: normal uncongested case with file name *2off-r.kr8*

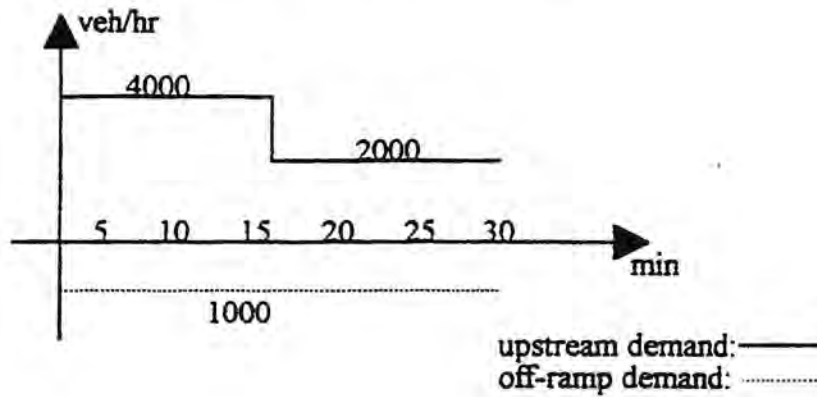

Figure 30 Demand pattern of two-lane off-ramp test case 1

Case 2: downstream restriction case with file name *2off-d.kr8*

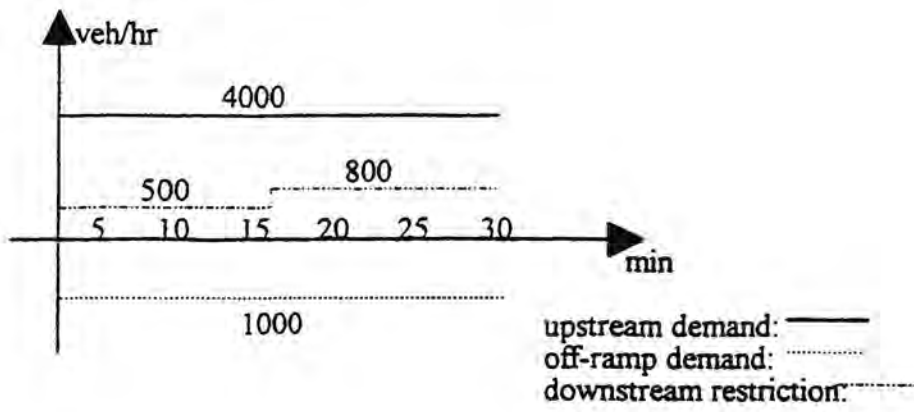

Figure 31 Demand pattern of two-lane off ramp test case 2

Case 3: capacity restriction case with file name *2off-r.kr8*

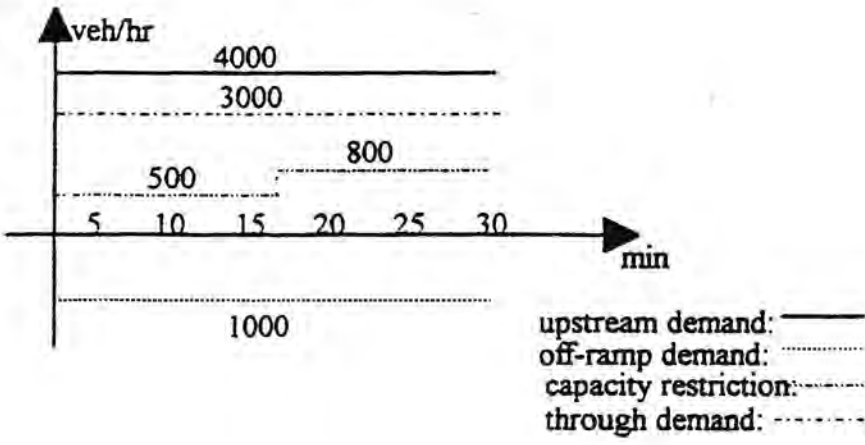

Figure 32 Demand pattern of two-lane off-ramp test case 3

- WEAVING TYPE

- Weaving section (segment type 4 and 7)

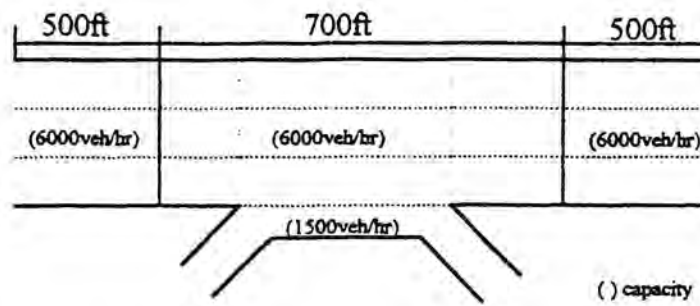

Figure 33 Geometric for weaving testing section

Case 1: normal uncongested case with file name *wea-n.kr8*

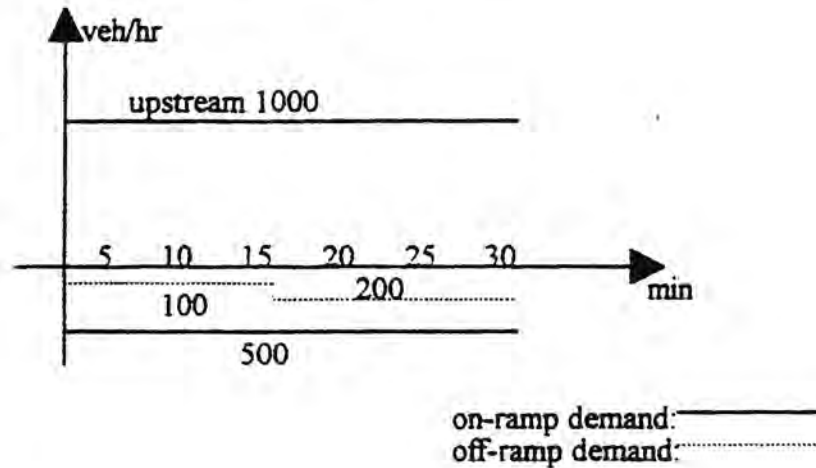

Figure 34 Demand pattern for weaving test case 1

Case 2: downstream restriction case with file name *wea-d.kr8*

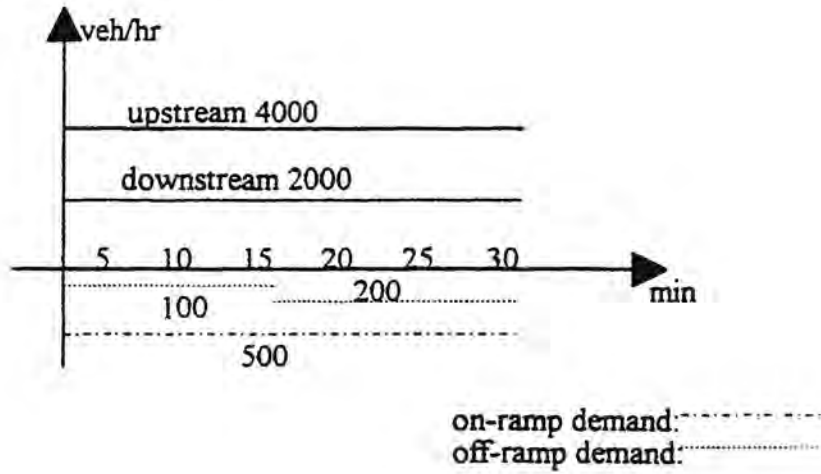

Figure 35 Demand pattern of weaving test case 2

Case 3: capacity restriction case with file name *wea-r.kr8*

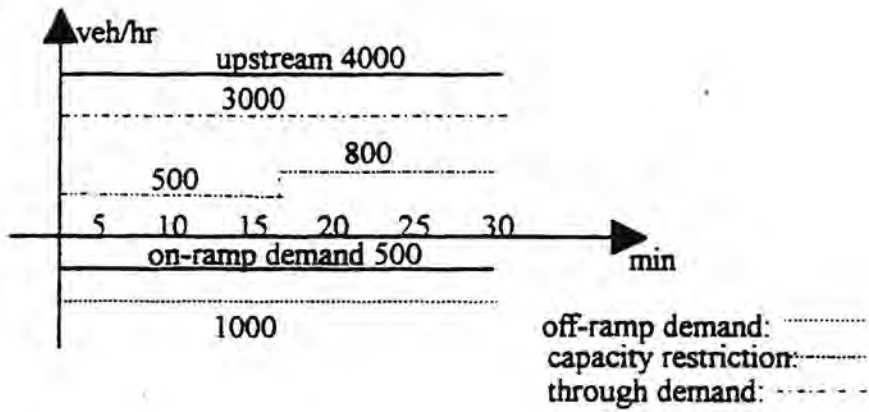

Figure 36 Demand pattern of weaving test case 3

Case 4: on-ramp metering case with file name *wea-m.kr8*

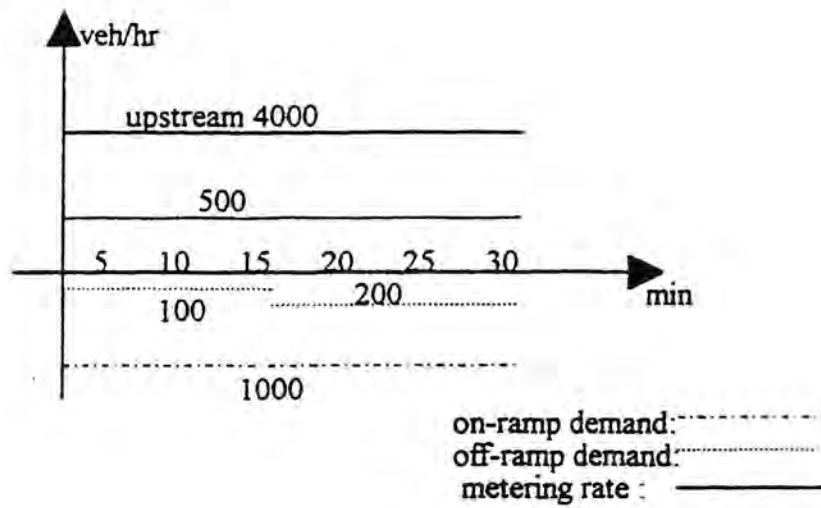

Figure 37 Demand pattern of weaving test case 4

2. Special weaving section (segment type 25)

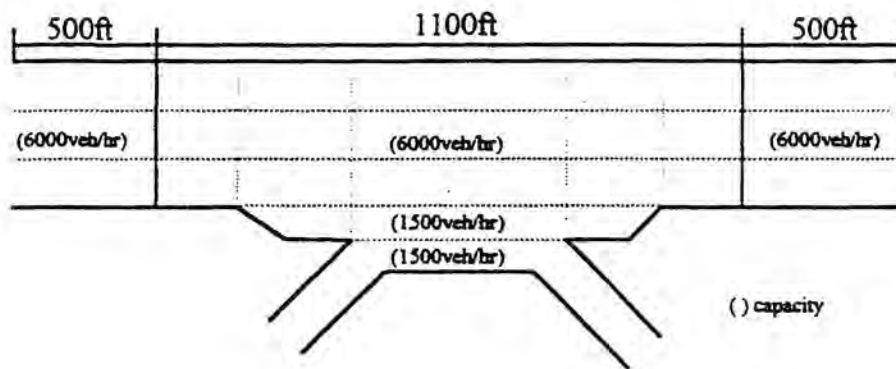

Figure 38 Geometric for special weaving testing section

Case 1: normal uncongested case with file name *swea-n.kr8*

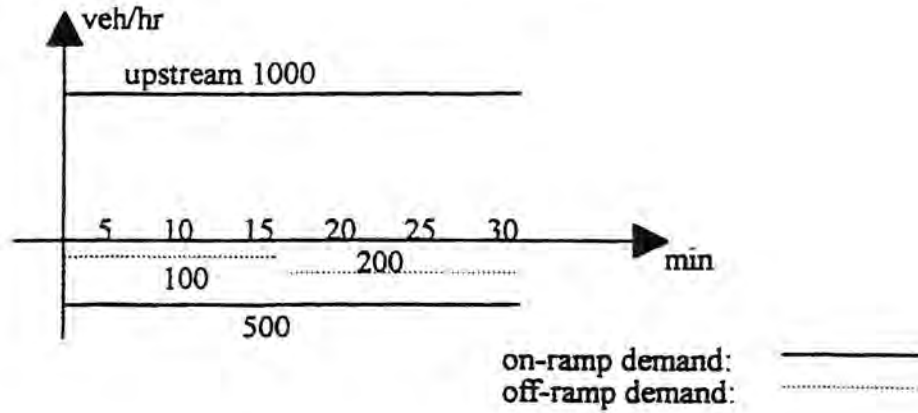

Figure 39 Demand pattern for special weaving test case 1

Case 2: downstream restriction case with file name *swea-d.kr8*

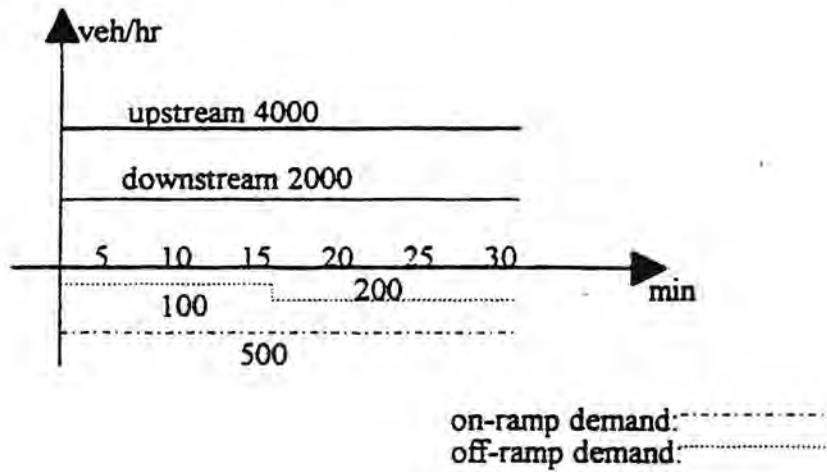

Figure 40 Demand pattern of special weaving test case 2

- COLLECT-DISTRIBUTE ROAD SECTION

1. Collect-distribute road section (segment type 16)

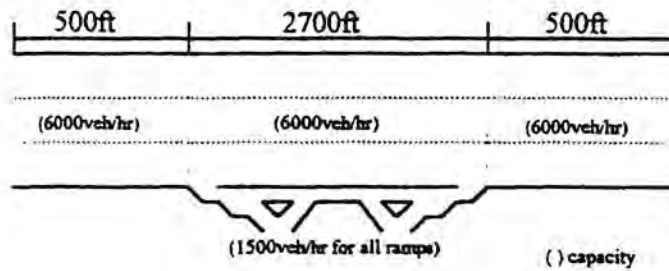

Figure 43 Geometric for collect-distribute testing section

Case 1: normal uncongested case with file name *cd-n.kr8*

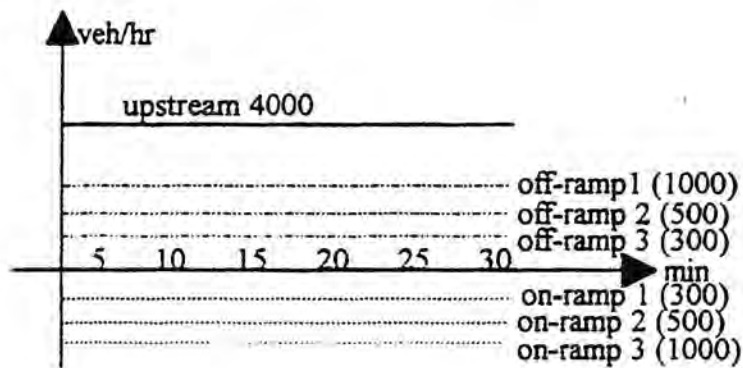

Figure 44 Demand pattern for collect-distribute test case 1

Case 2: downstream restriction case with file name *cd-d.kr8*

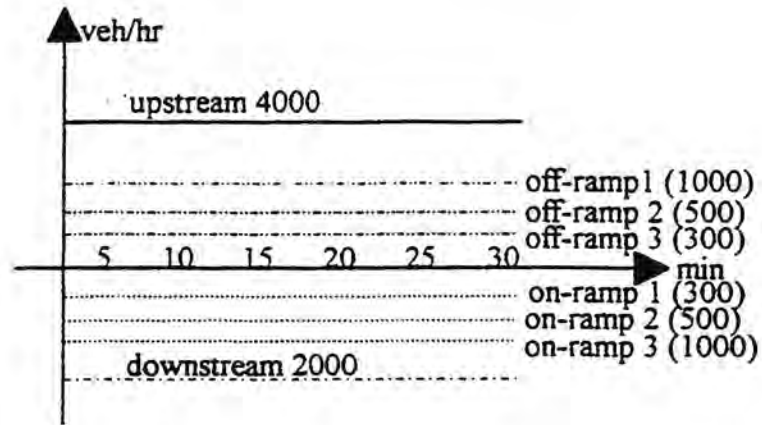

Figure 45 Demand pattern of collect-distribute test case 2

- LAND ADD/DROP TYPE

1. Land add section (segment type 14 and 15)

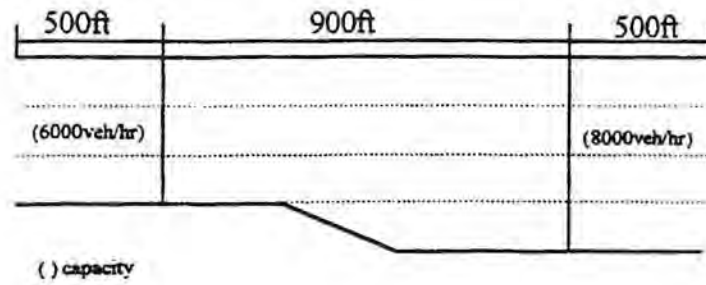

Figure 46 Geometric for land add testing section

Case 1: normal uncongested case with file name *landa-n.kr8*

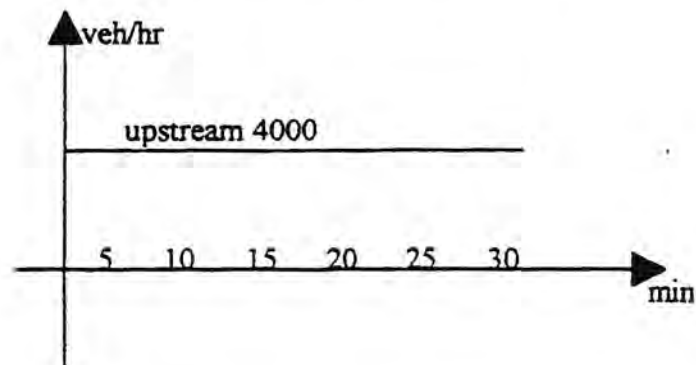

Figure 47 Demand pattern for land-add test case 1

Case 2: downstream constriction case with file name *landa-d.kr8*

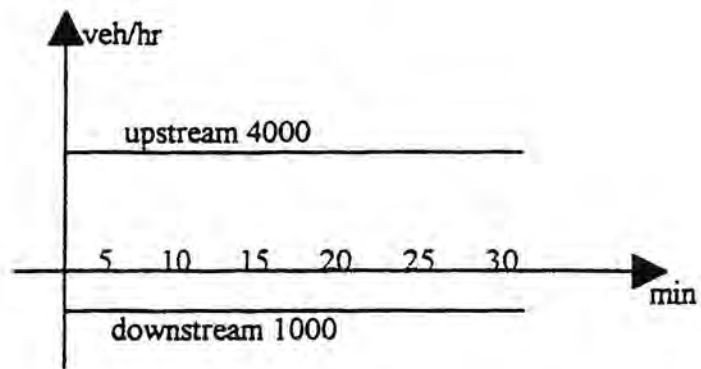

Figure 48 Demand pattern for land-add test case 2

2. Land drop section (segment type 12 and 13)

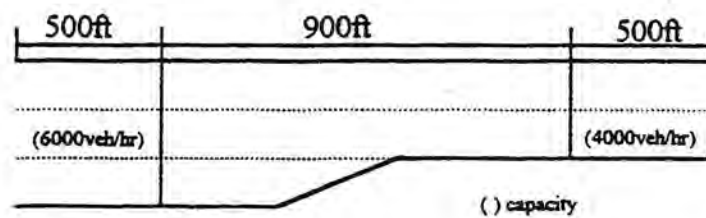

Figure 49 Geometric for land drop testing section

Case 1: normal uncongested case with file name *landp-n.kr8*

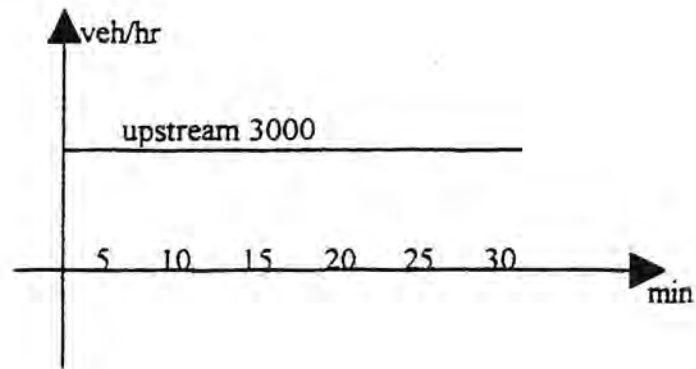

Figure 50 Demand pattern for land-drop test case 1

Case 2: downstream constriction case with file name *landp-d.kr8*

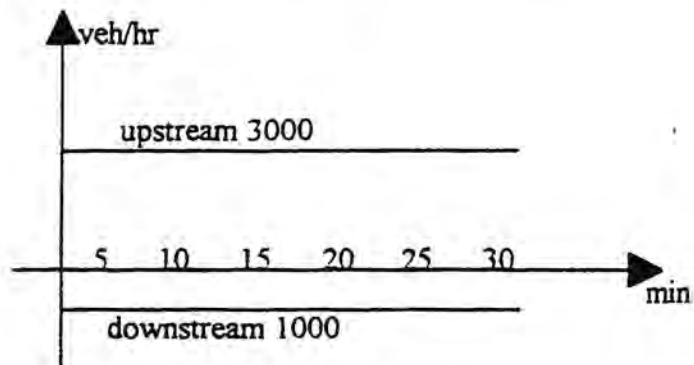
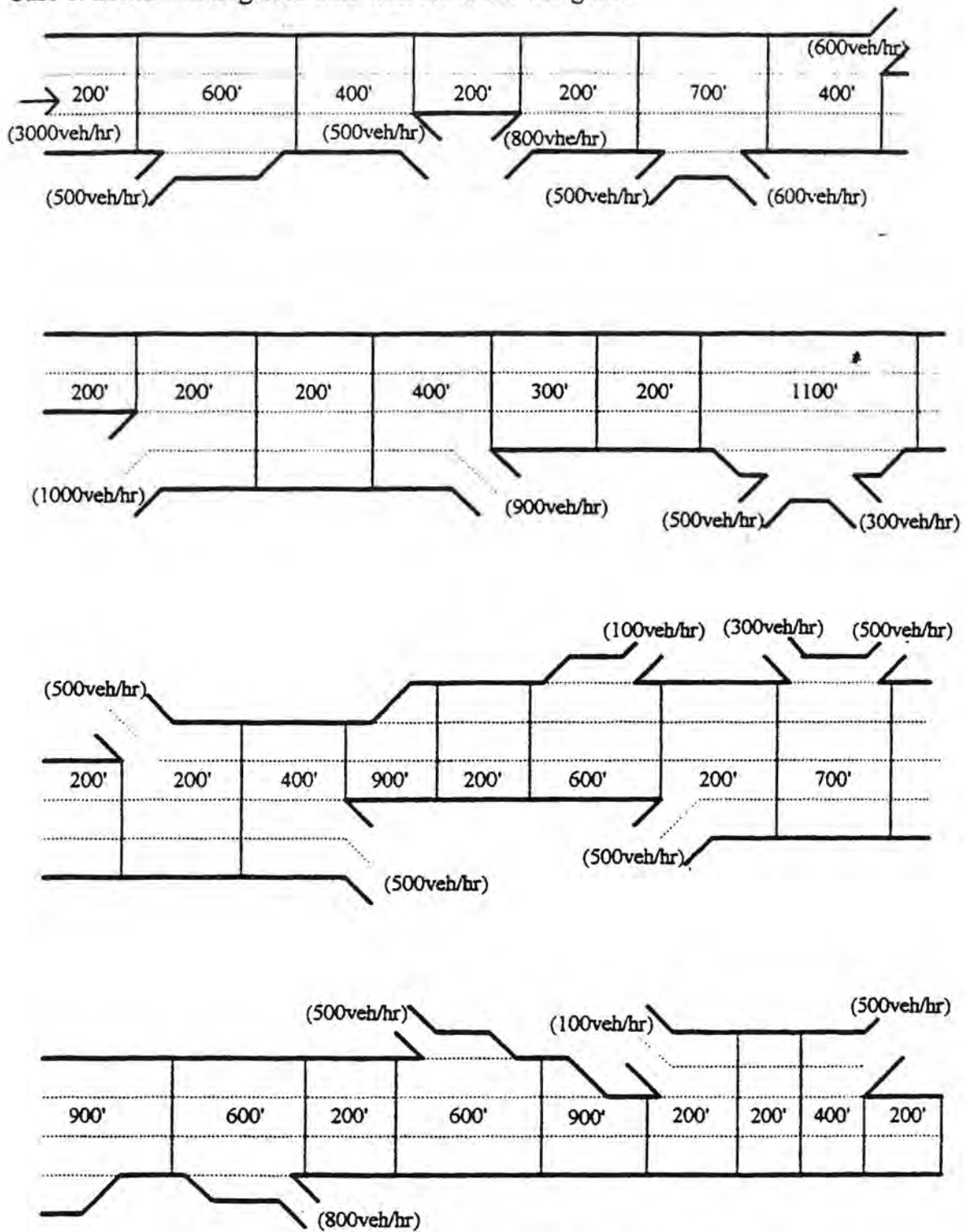

Figure 48 Demand pattern for land-drop test case 2

- HYPOTHETICAL FREEWAY SYSTEM

Case 1: normal uncongested case with file name *allseg.kr8*



() demand pattern

capacity is 2000veh/hr/lane

Case 2: downstream constriction case with file name *allseg-d.kr8*

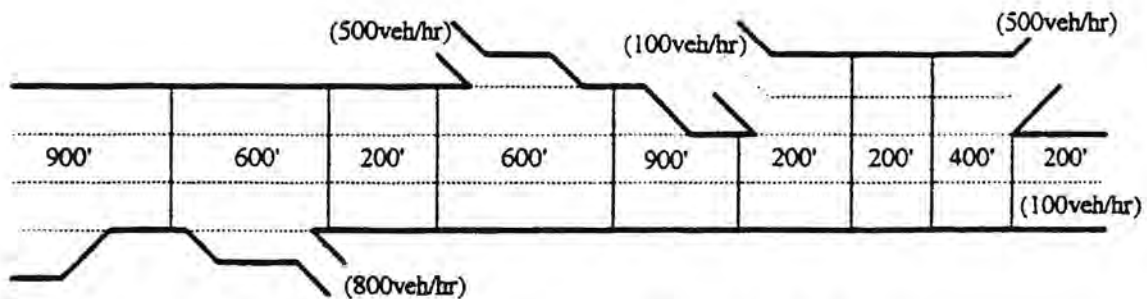
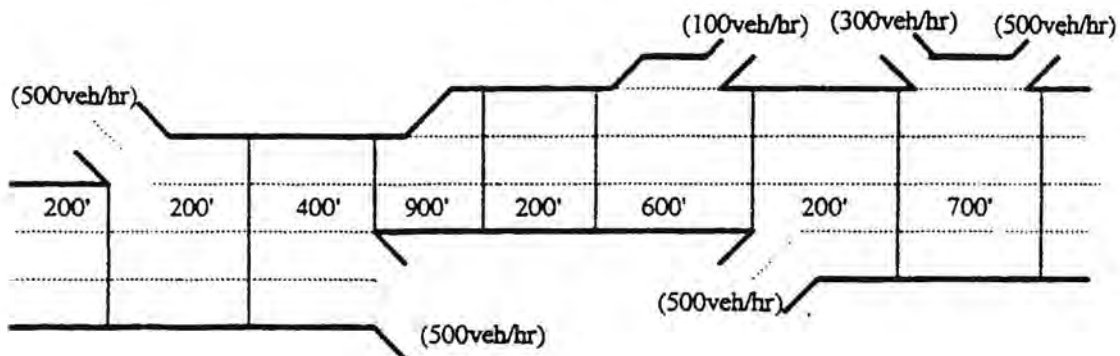
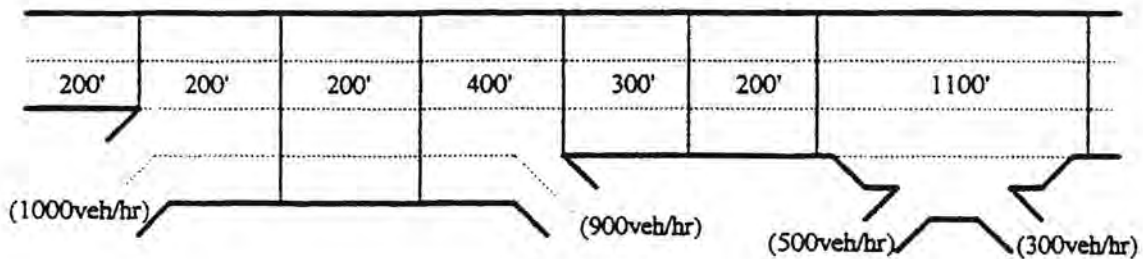
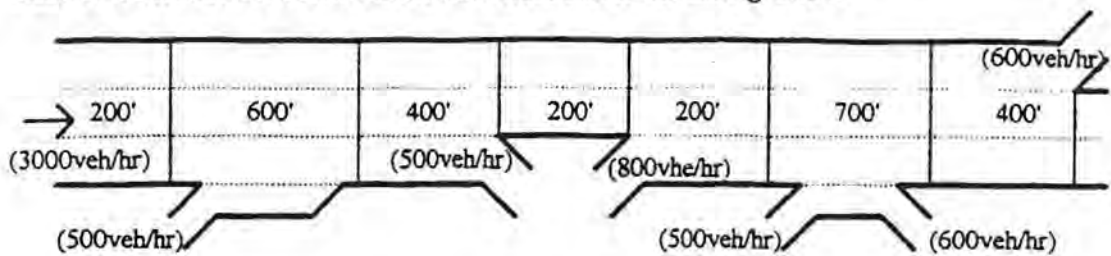

() demand pattern

capacity is 2000veh/hr/lane



APPENDIX D

KRONOS V8.0 USER'S MANUAL
(Separate document available from the author.)





Office of Research Administration
200 Ford Building, 117 University Avenue, Mail Stop 330
Saint Paul, Minnesota 55155



(612) 282-2272