

A REEXAMINATION OF THE PHILIPPINE-TYPE VOICE SYSTEM
AND ITS IMPLICATIONS FOR AUSTRONESIAN PRIMARY-LEVEL
SUBGROUPING

A DISSERTATION SUBMITTED TO THE GRADUATE DIVISION OF THE
UNIVERSITY OF HAWAI‘I AT MĀNOA IN PARTIAL FULFILLMENT OF THE
REQUIREMENTS FOR THE DEGREE OF

DOCTOR OF PHILOSOPHY

IN

LINGUISTICS

DECEMBER 2017

By

Victoria (Yen-hsin) Chen

Dissertation Committee:

Robert Blust, Co-chair

Shin Fukuda, Co-chair

Lyle Campbell

William O’Grady

Yuko Otsuka

Barry Rolett

Keywords: Philippine-type voice system, Austronesian-type voice system, comparative syntax,
Austronesian primary-level subgrouping, Formosan languages

*To Bob Blust,
who guided me through Austronesian comparative linguistics*

*To Atrung Kagi, Dakis Pawan, Lisin Kalitang, and Ivan Bondoc,
whose time and patience made this study possible*

Acknowledgements

This dissertation is a compilation of some questions that have intrigued me over the past several years and my attempt to answer these questions. I wish to first thank a few people without whom I could not have started thinking about these questions in the first place.

I am grateful to Dr. Robert Blust, who has guided me throughout my graduate study. His passion for Austronesian comparative linguistics and interest in looking at big-picture questions, as well as his honesty about data, have all had great influence on me. I cannot thank him enough for his guidance, encouragement, generous help with my writing, and firm support in pushing me to publish. I am delighted that the syntactic analyses presented in this dissertation have ended up nearly reflecting Bob's intuition from the first time we talked about these questions in 2014.

Dr. Shin Fukuda played an important role in the second half of my graduate study. Starting with a project on Puyuma RTO, he taught me how to think critically about syntactic data and how to approach a question step-by-step, and from this, I eventually became a syntactician. I am grateful to him for always being willing to spend time on my preliminary analyses, for his prompt email responses when I got stuck on a data question while in the field, and for critically critiquing my analyses and encouraging me when I was on to something. His insistence on clarity and deductive reasoning has greatly shaped this dissertation. Without him I would not like syntax so much.

I am grateful to my first linguistics professor, Dr. Ying-chin Lin at Academia Sinica for introducing me to historical linguistics and syntax and mentoring me through my graduate study. I am also grateful to Dr. William O'Grady for serving as a mentor on many topics, especially regarding this study and my professional career. I also want to thank him for always reminding me to think theory neutrally about syntactic data beyond the generative framework.

I also want to thank my other committee members, Drs. Lyle Campbell, Yuko Otsuka, and Barry Rolett, for their generous help and comments in the development of this study. I also thank Profs. Kamil Deen, Bley-Vroman, and Bradley McDonnell for their advice of different kinds.

- *Outside UHM*

I am deeply thankful to Dr. Elizabeth Zeitoun for being my host and sponsor during my fieldwork year in Taiwan, and to Academia Sinica for the pre-dissertation fellowship, which made this study possible.

I am very grateful to Drs. Malcolm Ross and Dan Kaufman for generously sharing their knowledge about Austronesian linguistics and kindly commenting on my papers and analyses. Both of them inspired the directions of this dissertation. I also thank Dan for the fun, productive fieldtrip in summer 2016.

I'd also like to thank the following people who I have had different degrees of contact with as I analyzed data and wrote this dissertation. Their comments and questions have helped improved this study in different ways: Edith Aldridge, Henry Chang, T.-C. Chen, Sandy Chung, Mitcho Erlewine, Hao-wen

Jiang, Dong-yi Lin, Diane Massam, Matt Pearson, Masha Polinsky, Omer Preminger, Norvin Richards, Yosuke Sato, Stacy Teng, Shigeo Tonoike, Lisa Travis, and Ilka Wild.

I'd also like to thank Maya Yeh and Dai-yu Chou for being wonderful officemates during my fieldwork year in Taiwan, and to Hong-rui Lin and Yen-zhuang Chen for generously introducing me to Kaxabu Pazeh.

- *Language teachers*

I am truly grateful to my language consultants: Atrung Kagi, Sawagu Kagi, Sunay Paelavang, Lisin Kalitang, Ofad Kacaw, Dakis Pawan, Yu-ru Chu, Chiu-kuei & Hana Dai, Yong-li Pan, Sharon Estioca, and Ana Bondoc. Their time, patience, and willingness to share their language have made this study possible. I am especially grateful to *sense* Atrung, Lisin, and Dakis for being such wonderful teachers. I am honored to be a learner of Puyuma, Amis, and Seediq!

I owe a great debt to my good friend and Tagalog consultant, Ivan Bondoc, with whom I was able to include Tagalog as a target language in this study. I am sincerely grateful to him for teaching me about his language and for always correcting my Formosan-style grammar and morphology patiently.

- *Friends*

Thank you to the following persons who have made life at UHM so happy: Ivan Bondoc, Amber Camp, Sunju Kim, Daniel Lin, Kirsten Helgeson, Ryan Henke, Mayumi Oiwa-Bungard, Andrew Pick, Nozomi Tanaka, Xuan Guan, and Sejung Yang. Thank you to Katie and Matt Gao for being my “life agents” in Hawai‘i. Thank you to Jonathan Kuo for being a great colleague, research buddy, and good friend, and for generously tutoring me in LING 422 when I just started, when case, agreement, and voice really confused me.

I would also like to thank Sharon Estioca, Raina Heaton, Tyler Heston, Nala Lee, Christian Mortensen, Colleen O’Brien, Eve Okura-Koller, Sam Rarrick, Brad Rentz, Melody Ann Ross, Hiroko Sato, Peter Schuelke, and John Van Way for chats/suggestions/help and the happy times we spent together.

I also want to thank the following persons who have kindly proofread my papers and given useful suggestions on writing: Andrew Pick, Amber Camp, Christian Mortensen, Daniel Lin, Katie Gao, Ryan Henke, and Tyler Heston.

Finally, I am extremely thankful to my parents for their love and care throughout the years of my graduate study, and to my partner, for his incredible support, patience, and unfailing love. I love you very much.

* * * * *

This dissertation was funded by the Academia Sinica Research Fellowship for Doctoral Candidates in the Humanities and Social Sciences, the UHM Linguistics Department Endowment Fund, and an Excellence in Doctoral Dissertation Research Award from the College of LLL at UHM. I also benefited from support from the Chiang Ching-Kuo Foundation Research Grant through the collaborative project with Dr. Daniel Kaufman at Queen’s College, CUNY.

Abstract

This dissertation investigates the nature of the Philippine-type voice system and two associated diachronic questions: (i) what is the nature of *noun-verb (nominalizer-voice affix) homophony*, a common trait of Philippine-type languages?, and (ii) does the synchronic variation of this voice system among higher-order Austronesian languages constitute valid evidence for Austronesian primary-level subgrouping? Using novel comparative data from Puyuma, Amis, Seediq, and Tagalog as the empirical starting point, I explore the shared syntax of Philippine-type languages and its implications for these two questions.

In the first half of the study, I argue that Philippine-type languages are best analyzed as exhibiting a nominative-accusative case system with prominent topic-marking that overrides morphological case. I then provide a novel account for the nature of the four-way division of the Philippine-type voice morphology: the four affixes are best analyzed as the spell-out of four different bundles of Agree relations that agree with the topic of a clause. Under this analysis, Philippine-type “voice” is fundamentally different from Indo-European “voice”. The latter is valency-rearranging morphology, while the former is topic-indicating morphology. Building on this analysis, I argue that Philippine-type languages are best characterized as *discourse configurational languages* (Li & Thompson 1976; Kiss 1995; Miyagawa 2010, 2017), whose topic-prominent nature is manifested both in prominent topic-marking and in articulated verbal morphology that indicates the Agree relations of the topic in a clause. I conclude that Philippine-type languages are best analyzed as hosting a topic-feature on C and the ϕ -feature on T, with topic-agreement spelled-out as verbal morphology.

In the second half of the study, I demonstrate how this synchronic syntactic analysis enables a simpler solution to two central issues in Austronesian diachronic linguistics (i)-(ii). Building on the conclusions outlined above, I argue that the presence of either (a) *nominalizer-voice affix homophony*, or (b) *Philippine-type voice distinctions in root-clause environments* does not constitute valid evidence for Austronesian primary-level subgrouping, as the absence of both features reflects independent morphological erosions in innovative languages. I conclude that phonological innovations are better evidence for Austronesian primary-level subgrouping than the morphosyntactic variation among higher-order Philippine-type languages, as the latter is best viewed as a product of independent drifts, rather than shared innovations.

Table of contents

Acknowledgement	iv
Abstract	vi
List of tables	xii
List of figures	xv
Abbreviations	xvi
§ 1 Introduction	1
1.1 Introduction	1
1.2 Outline of the study	4
1.3 What is a Philippine-type voice system?	7
1.4 Methodology and a note on the target languages	10
1.4.1 Methodology	11
1.4.2 A note on Formosan languages	12
1.4.3 Backgrounds of the target languages: Puyuma, Amis, Seediq, and Tagalog	13
1.4.4 Other languages surveyed in this study	18
1.5 Theoretical assumptions	19
1.5.1 Agree and Merge	19
1.5.2 The division of Voice and <i>v</i>	19
1.5.3 Case and Case-licensing	20
1.5.4 Distributed Morphology	21
§ 2 Reconsidering Philippine-type Actor voice	23
2.1 Introduction	23
2.2 Philippine-type Actor voice basics	27
2.2.1 Philippine-type Actor voice: Overview	27
2.2.2 The AV/PV asymmetry	31
2.3 Issues in the intransitive approach to Philippine-type Actor voice clauses	32
2.3.1 Basic assumptions of the intransitive analysis of Actor voice	33
2.3.2 Previous formal approaches to the intransitive analysis of Actor voice	34
2.3.3 Issues in the antipassive analysis of Philippine-type AV clauses	36
2.4 The competing analyses	43
2.5 Types of accusative Case behaviors of Y-marking	45
2.5.1 Productive causatives: The ECM-behavior of Y-marking	45
2.5.2 Raising-to-object: The presence of Y in nonthematic position	53
2.5.3 Restructuring: The absence of Y in embedded infinitives	56
2.6 The compatibility of “antipassives” with detransitivization	60
2.6.1 The detransitivizing analysis of the MU-construction	62

2.6.2	Seediq MU-construction and its implications	65
2.6.3	MU- = AV affix <i>m-</i> + detransitivizer <i>u-</i>	67
2.6.4	The nature of Philippine-type Actor voice: Evidence from the MU-clauses	70
2.7	Conclusion and implication	71
§ 3	The nature of the argument marker X	73
3.1	Introduction	73
3.2	The competing analyses	75
3.2.1	The inherent ergative Case analysis of X	75
3.2.2	Claim: X marks structural nominative Case	77
3.2.3	The competing analyses and their predictions of the distribution of X	78
3.3	Observation 1: The distribution of X is insensitive to transitivity, and appears outside the external argument position	79
3.3.1	The presence of X in unaccusative-like constructions	79
3.3.2	Unaccusativity in Puyuma, Amis, Seediq, and Tagalog	81
3.3.3	X marks nominative Case	87
3.4	Observation 2: X is unique per CP and subject to locality	88
3.4.1	The structure and argument-marking pattern in AV- and CV-causatives	89
3.4.2	The distributional restriction of X in productive causatives	91
3.4.2	X marks structural nominative Case	92
3.5	Implications: Against a split-ergative analysis for the Philippine-type voice system	93
3.6	Conclusion	94
§ 4	Pivot ≠ Absolutive/nominative	95
4.1	Introduction	95
4.2	Previous analyses of Philippine-type “Pivot”-marking	96
4.2.1	“Pivot” as the realization of absolutive/nominative Case	97
4.2.2	“Pivot” as a topic marker	97
4.2.3	The Pivot as bearing both subject and topic status	98
4.3	Issues in the absolutive Case analysis of Philippine-type “Pivot”-marking	98
4.3.1	The absolutive/nominative Case analysis of “Pivot”-marking	98
4.3.2	The Minimalist approach to the absolutive/nominative Case analysis of “Pivot” marking	100
4.3.3	Issues in the high applicative analysis of the LV/CV clauses	103
4.4	Pivot ≠ Absolutive/nominative	108
4.4.1	The predicted distribution of “Pivot”-marking under the absolutive/nominative Case analysis	109
4.4.2	Productive causatives	111
4.4.3	Ditransitives	119
4.4.4	Simple clauses with a non-core phrase as the Pivot	126
4.4.5	A note on Malagasy and Subanon	130
4.5	The argument-marking mechanism of the Philippine-type voice system	132
4.6	Philippine-type voice system ≠ split ergativity between AV and non-AV clauses	133
4.7	Conclusion	134

§ 5	The nature of the Philippine-type voice system	135
5.1	Introduction	135
5.2	Claim: “Pivot” is a topic marker	136
5.2.1	Proposal: “Pivot” marks topic	136
5.2.2	Argument 1: “Pivot” marks discourse topics	138
5.2.3	Argument 2: Pivot phrases share argument marking with hanging topics	144
5.2.4	Argument 3: “Pivot” marks presupposed information in pseudo clefts	145
5.2.5	Proposal: “Pivot”-marking overrides morphological case	148
5.3	The nature of the Philippine-type voice affixes	150
5.3.1	Main traits of the Philippine-type voice affixes	150
5.3.2	Previous analyses of Philippine-type voice affixes	155
5.3.3	Proposal: Philippine-type voice affixes are the spell-out of four different bundles of Agree relations	159
5.4	Evidence for voice affixes as agreement morphology	173
5.4.1	Evidence from Pivot placement in productive causatives with multiple embedded VoicePs	173
5.4.2	Evidence from the voice-marking restriction on non-main verb within a CP	176
5.5	Conclusion: What makes a Philippine-type voice system?	177
5.5.1	The design of the Philippine-type voice system	178
5.5.2	Philippine-type languages as discourse-configurational languages	179
5.5.3	Conclusion	180
§ 6	Austronesian primary-level subgrouping: Current issues	181
6.1	Introduction	181
6.1.1	The puzzle	181
6.1.2	Austronesian primary-level subgrouping: Overview	184
6.2	Reconsidering Approach A: The phonological evidence	185
6.2.1	What constitutes reliable phonological evidence for linguistic subgrouping?	185
6.2.2	Phonological evidence for Austronesian primary-level subgrouping: Overview	186
6.2.3	Reconsidering three divergences between Ho (1998) and Blust (1999)	191
6.2.4	Interim conclusion	196
6.3	Reconsidering Approach B: N/V homophony	196
6.3.1	Synchronic observation	197
6.3.2	Approach B and the Nuclear Austronesian Hypothesis revisited	200
6.3.3	Interim summary	204
6.4	Reconsidering Approach C: Ergativity (/Philippine-type voice distinctions)	204
6.4.1	The synchronic facts	204
6.4.2	Approach C and the Ergative Austronesian hypothesis revisited	205
6.4.3	Interim summary	206
6.5	Conflicts among Approaches A, B, and C	207
6.5.1	Conflict 1: The validity of Tsouic	207
6.5.2	Conflict 2: “Nom-into-V”: The phonological non-evidence	209
6.5.3	Conflict 3: The status of Rukai and Tsou	210
6.5.4	Conflict 4: Divergences in homeland inferences	211
6.5.5	Summary of the conflicts	212

6.6	Evaluations	212
6.6.1	Methodological soundness	212
6.6.2	Compatibility with the proposed analyses for synchronic Austronesian syntax	213
6.6.3	Compatibility with two types of nonlinguistic inferences for subgrouping	214
6.7	Conclusions and implications	217
§ 7	The nature of Austronesian “nominalizer-voice affix homophony” and its synchronic variation	219
7.1	Introduction	219
7.2	Three common issues in morphosyntactic reconstruction	221
7.2.1	The directionality problem	221
7.2.2	The pitfalls of negative evidence	222
7.2.3	Issues in proposing replacement reanalysis at treetop	223
7.2.4	What constitutes a reliable morphosyntactic reconstruction?	224
7.3	Austronesian N/V homophony: An alternative account and why Nominalization-into-verb is not a sound proposal	225
7.3.1	The Nominalization-into-verb hypothesis: Overview	225
7.3.2	Austronesian N/V homophony: An alternative account	232
7.3.3	Issues in the Nominalization-into-verb hypothesis	235
7.3.4	Final remark: Against an insubordination analysis	238
7.3.5	Interim conclusion	238
7.4	The nature of the absence of “N-V” homophony and the directionality issues in the NAn hypothesis	239
7.4.1	The Nuclear Austronesian hypothesis revisited	240
7.4.2	The synchronic facts revisited	241
7.4.3	Evidence for a unitary directionality of loss	245
7.4.4	A note on possessor-X homophony	249
7.5	Where’s the old morphology? In relative clauses.	249
7.5.1	Root clauses are innovative, subordinate clauses are conservative	250
7.5.2	Extra-Formosan parallels	250
7.5.3	Support from the Economy Principle	251
7.6	Conclusion	253
§ 8	Conclusion	254
8.1	A recap of the main claims of this study	254
8.2	Implications	258
	Appendix I: The locus of the Pivot and the word order variation in Philippine-type languages	259
	Appendix II: The “Pivot-only” constraint revisited	268
	Appendix III: The nature of Austronesian “nominalzier/voice affix” homophony	275
	Appendix IV: The prototypical argument-marking pattern of Philippine-type languages	277
	References	281

List of tables

Table 1.1. Basic argument-marking pattern in Philippine-type languages	9
Table 1.2. Prototypical Philippine-type voice morphology	9
Table 1.3. The shared pattern in Pivot-selection in Philippine-type languages	9
Table 1.4. The shared argument-marking pattern in productive causatives	11
Table 1.5. Backgrounds of Puyuma, Amis, Seediq, Tagalog	13
Table 1.6. Indicative voice morphology of Puyuma, Amis, Seediq, and Tagalog	14
Table 1.7. The argument-marking patterns of the target languages	15
Table 2.1. Argument-marking alternation in Philippine-type 2-place AV and PV clauses	25
Table 2.2. AV variants in Puyuma, Amis, Seediq, and Tagalog	27
Table 2.3. Argument-marking pattern in Philippine-type AV clauses	29
Table 2.4. The ergative approach to AV/PV asymmetry	33
Table 2.5. Default aspectual interpretation in six Philippine-type languages	43
Table 2.6. Shared argument-marking between Causee and AV objects	46
Table 2.7. Shared argument-marking between Causee and AV objects	56
Table 2.8. 2-place verbs compatible with a MU-construction in Puyuma, Thao, and Bunun	63
Table 2.9. Instances of initial vowel deletion in Seediq	66
Table 2.10. Argument-marking pattern in Philippine-type AV and PV clauses	72
Table 2.11. Evidence for a transitive analysis of Philippine-type 2-place AV clauses	72
Table 3.1. The argument-marking alternation between Philippine-type AV and PV clauses	73
Table 3.2. The shared argument-marking pattern across Philippine-type languages	75
Table 3.3. Predictions of the competing analyses (X=ERG vs. X=NOM)	78
Table 3.4. Morphological distinction in the AV voice affixes in Puyuma, Amis, and Seediq	82
Table 3.5. The shared argument-marking pattern in productive causatives	89
Table 3.6. The argument-marking pattern under the split ergative analysis	93
Table 4.1. The argument-marking alternation between Philippine-type AV and PV clauses	85
Table 4.2. Shared argument-marking pattern across Philippine-type languages	99

Table 4.3. Possible candidates of Pivot phrases in LV/CV clauses	104
Table 4.4. Prototypical Philippine-type voice morphology	107
Table 4.5. The shared argument-marking pattern in productive causatives	111
Table 4.6. The shared argument-marking pattern in productive causatives	116
Table 4.7. The shared argument-marking pattern in productive causatives	120
Table 4.8. The argument-marking pattern in Subanon ditransitives	131
Table 4.9. The shared argument-marking pattern in ditransitives under the current analysis	133
Table 4.10. The argument-marking pattern in ditransitives under the current analysis	133
Table 4.11. Argument-marking patterns according to the split-ergative analysis	133
Table 5.1. The argument-marking alternation between Philippine-type AV and PV clauses	135
Table 5.2. The shared morphological form between Pivot-marking and the linker in pseudo-clefts	146
Table 5.3. Proposal: the nature of the shared argument-marking pattern in Philippine-type languages	149
Table 5.4. The thematic role and structural position of the Pivot in types of basic constructions	151
Table 5.5. Mood inflections in Proto-Austronesian voice morphology	152
Table 5.6. Previous approaches to Philippine-type voice affixes	158
Table 5.7. The structural position of the Pivot in different constructions	159
Table 5.8. The mapping between argument-marking and voice-marking in Philippine-type languages	177
Table 5.9. Proposal: the nature of the shared argument-marking pattern in Philippine-type languages	178
Table 6.1. Shared innovations that define the Malayo-Polynesian (MP) branch	184
Table 6.2. Proto-Austronesian consonant systems adopted in Ho (1998) and Blust (1999)	188
Table 6.3. Sound correspondences among higher-order Austronesian languages	189
Table 6.4. Phonological innovations used in Ho (1998) and Blust (1999)	189
Table 6.5. The treatment of Bunun and East Formosan languages: Ho (1998) vs. Blust (1999)	192
Table 6.6. The correspondences of PAn *s and *S in different PAn reconstruction systems	193
Table 6.7. The correspondences of Rukai and Tsouic sibilants	194
Table 6.8. Morphological paradigms in Rukai, Tsou, Puyuma, and prototypical languages	200
Table 6.9. Proto-Rukai morphology	205
Table 6.10. Shared sociocultural features among Tsou, Saaroa, and Kanakanavu	209
Table 6.11. The phoneme inventories of higher-order branches under the NAn hypothesis	209

Table 6.12. Summary of the conflicts among Approaches A, B, and C	212
Table 6.13. Main cultures of Formosan aborigines (Ferrell 1969)	216
Table 7.1. Mood distinctions in conservative Philippine-type languages	226
Table 7.2. Argument-marking pattern in the Philippine-type voice system	230
Table 7.3. The Nominalization-into-verb hypothesis	231
Table 7.4. The mapping between Pivot-selection and voice-marking in (prototypical) Philippine-type languages	237
Table 7.5. The variation in N-V homophony among higher-order Austronesian languages	239
Table 7.6. Seediq voice morphology	242
Table 7.7. Proto-Rukai voice morphology	242
Table 7.8. Tsou voice morphology	243
Table 7.9. (Proto-)Puyuma voice morphology	243
Table 7.10. Saaroa voice morphology	244
Table 7.11. Kanakanavu voice morphology	244
Table 7.12. Possessor-genitive (X) homophony in Puyuma	245
Table 7.13. Possessor-genitive (X) homophony in Tsou	245
Table 7.14. Pre-P-”Nom-into-V” morphology under Ross (2012) and Aldridge (2016)	248
Table 7.15. The Proto-Austronesian voice system under the present analysis	249
Table 7.16. Required innovations under the current analysis	252
Table 7.17. Required innovations under the Nuclear Austronesian hypothesis (Approach B)	252
Table 8.1. The basic argument-marking pattern in Philippine-type AV and PV clauses	254
Table 8.2. Proposal: the argument-marking mechanism of the Philippine-type voice system	255
Table 8.3. The shared argument-marking pattern among Philippine-type languages	255
Table 9.1. The prototypical argument-marking pattern in Philippine-type languages	277
Table 9.2. The argument-marking system of PAn, PMP, and PPh	278
Table 9.3. The argument-marking pattern and pronominal paradigm of Paiwan, Amis, and Botolan Sambal	279
Table 9.4. The lack of X/Y distinction in Tagalog’s common noun marking system	279
Table 9.5. The argument-marking paradigm of two Puyuma dialects	280

List of figures

Figure 1.1. Austronesian primary-level subgrouping based on phonological evidence	4
Figure 1.2. The positions of Formosan languages in the Austronesian language family	12
Figure 1.3. The geographical location of Puyuma, Amis, Seediq, and Tagalog	13
Figure 6.1. Subgrouping Approach A: Exclusively shared phonological innovations	182
Figure 6.2. Subgrouping Approach B: Presence or absence of N-V homophony	182
Figure 6.3. Subgrouping Approach C: Presence or absence of ergativity (/Philippine-type voice)	183
Figure 6.4. Austronesian primary-level subgrouping: the current issue	185
Figure 6.5. Ho's (1998) subgrouping	187
Figure 6.6. Blust's (1999) subgrouping	187
Figure 6.7. The position of Bunun: Ho (1998)	191
Figure 6.8. The position of Bunun: Blust (1999)	192
Figure 6.9. Two interpretations of the discrepancy in N-V homophony	201
Figure 6.10. The purported evolutionary pathway of N-V homophony	201
Figure 6.11. Austronesian primary-level subgrouping under the NAn hypothesis	202
Figure 6.12. The purported ordering of the Nominalization-into-verb innovation	203
Figure 6.13. Revised Austronesian primary-level subgrouping under Approach B	203
Figure 6.14. Two interpretations of the discrepancy in N-V homophony	205
Figure 6.15. Subgrouping proposal under (29a)	206
Figure 6.16. Subgrouping proposal under Approach C	206
Figure 6.17. The validity of Tsouic	207
Figure 6.18. Homeland inferences under Hypotheses A, B, and C	211
Figure 6.19. Approach A: The phonology-based subgrouping	217
Figure 7.1. The Nuclear Austronesian hypothesis	220
Figure 7.2. Revised Nuclear Austronesian hypothesis under Zeitoun & Teng (2016)	241
Figure 7.3. The presence or absence of a reflex of *-en	248
Figure 8.1. Austronesian primary-level subgrouping evidenced by sound changes (Blust 1999)	257

List of abbreviations

1	first person	LK	linker
2	second person	LOC	locative
3	third person	LV	locative voice
ABS	absolutive	NEG	negative
ACC	accusative	NMZ	nominalizer
AFF	affirmative	NOM	nominative
AOR	aorist	NONFUT	nonfuture
AP	antipassive	NVOL	nonvolitional
AUX	auxiliary	OBL	oblique
AV	actor voice	OBLV	oblique voice
C	complementizer	OPT	optative
CAU	causative	OV	object voice
CL	classifier	P	preposition
CM	case marker	PART	particle
CN	common noun	PASS	passive
CONJ	conjunction	PL	plural
CONT	contemplated aspect	PN	personal name marker
COP	copula	POSS	possessive
CV	circumstantial voice	PRET	preterite
DAT	dative	PRF	perfect
DEM	demonstrative	PROG	progressive
DET	determiner	PST	past
DETR	detransitive	PT	patient
DF	definite	PV	patient voice
DOM	differential object marker	RC	relative clause
EMD	embedded	RED	reduplication
EMPH	emphatic	RFL	reflexive
EXCL	exclusive	RLS	realis
EXI	existential	SF	singular.feminine
ERG	ergative	SG	singular
F	feminine	SM	stem marker
GEN	genitive	STAT	stative
ID	indefinite	SUBJ	subject
IMP	imperative	SV	subject voice
IMPF	imperfective	TOP	topic
IND	indicative	TR	transitive
INF	infinitival		
INS.M	instrument marker		
INTR	intransitive		
IRR	irrealis		

Chapter 1

Introduction

A central question in Austronesian syntax concerns the nature of the *Philippine-type voice system*, a typologically unique grammatical system found in nine of the ten Austronesian primary branches. Over the past several decades, much debate has revolved around the alignment pattern, argument-marking mechanism, and the nature of a special A'-extraction constraint found in languages that possess this voice system. Despite existing work on individual languages, the core syntax of this voice system remains unclear due to a lack of both interlanguage comparisons and in-depth investigations of basic constructions in these languages.

This dissertation fills this gap by looking into the shared syntax of Philippine-type languages. Drawing on novel comparative data from four languages (Puyuma, Amis, Seediq, Tagalog) representing four different Austronesian primary branches, I argue that a prototypical Philippine-type language exhibits a nominative-accusative case system with prominent topic-marking that overrides morphological case. Building on this analysis, I provide a novel account for the nature of the four-way division of the Philippine-type voice morphology, and argue that Philippine-type languages are best analyzed as *discourse configurational languages* (Li & Thompson 1976; Kiss 1995; Miyagawa 2010, 2017), whose topic-prominent nature is manifested in both (i) prominent topic-marking and (ii) articulated verbal morphology that indexes the role of the topic in a clause. Building on this conclusion, I reconsider several diachronic issues in Austronesian linguistics. I argue that certain morphosyntactic traits of this voice system that were previously considered innovative are in fact prototypical (retentive) of the voice system, and therefore do not constitute evidence for linguistic subgrouping. These include the well-known phenomenon of *nominalizer-voice affix homophony*, as well as a four-way voice distinction in root clauses. I conclude that phonological innovations are better evidence for Austronesian primary-level subgrouping than these two types of morphosyntactic variations among higher-order Philippine-type languages, as the changes that gave rise to the latter reflect independent drifts, rather than shared innovations.

1.1 Introduction

This dissertation investigates the core syntax of the *Philippine-type voice system*, a typologically peculiar grammatical system found in higher-order Austronesian languages that has triggered much debate in theoretical syntax. As is well known, in Philippine-type languages, a change in verbal morphology correlates with an alternation in argument-marking and A'-extraction restriction in a

clause. As seen in the Paiwan examples (1), the presence of a different affix on the verb rearranges the argument-marking pattern in the clause. The label “Pivot” indicates that the phrase is eligible to undergo A’-extraction (relativization or pseudo-clefting); the label X stands for the marking on non-Pivot external arguments; the label Y stands for the marking on non-Pivot internal arguments and obliques.

(1) *Paiwan*

- a. q<m>alup a caucau tua vavuy i gadu tua vuluq.
 <AV>hunt PIVOT man Y pig LOC mountain Y spear
 ‘The man hunts wild pigs in the mountains with a spear.’
- b. qalup-en nua caucau a vavuy i gadu tua vuluq.
 hunt-PV X man PIVOT pig LOC mountain Y spear
 ‘The man hunts *wild pigs* in the mountains with a spear.’
- c. qalup-an nua caucau tua vavuy a gadu tua vuluq.
 hunt-LV X man Y pig PIVOT mountain Y spear
 ‘The man hunts wild pigs *in the mountains* with a spear.’
- d. si-qalup nua caucau tua vavuy i gadu a vuluq.
 CV-hunt X man Y pig LOC mountain PIVOT spear
 ‘The man hunts wild pigs in the mountains *with a spear*.’ (Ferrell 1979:202)

Much previous work has disagreed on whether the alternation in verbal morphology in (1a)-(d) reflects a *valency-rearranging operation* that promotes different phrases to subject status (e.g., De Guzman 1976; Payne 1982; Guilfoyle, Hung, & Travis 1992; Mithun 1994; Aldridge 2004, 2008, 2011, 2017), or a change in the *information structure* of the clause (e.g., Schachter 1976; Shibatani 1988; Richards 2000; Pearson 2001, 2005; Rackowski 2002; Rackowski & Richards 2005). Drawing on new data from four Philippine-type languages under different Austronesian primary branches, this dissertation presents an improved analysis of the latter, and argues that the “Pivot”-marked phrases in (1a)-(d) are best analyzed as the internal topic of the clause.

In the first half of this dissertation, I investigate the nature of the Philippine-type voice system. Drawing on novel comparative data centered on a number of understudied constructions in Puyuma, Amis, Seediq, and Tagalog, I argue that a prototypical Philippine-type voice system exhibits an accusative case system with prominent topic-marking that overrides morphological case. In approaching this analysis, I demonstrate that the labels X and Y in (1) show the hallmarks of nominative and accusative Case, respectively, and that of the marker ‘Pivot’ is best analyzed as a topic marker that overrides X, Y, and the locative marker *i*. Building on this analysis, I demonstrate that the four-way division of Philippine-type voice morphology is best analyzed as the spell-out of four different bundles of Agree relations that agree with the topic (i.e., Pivot) in the clause. Under this analysis, I propose that Philippine-type voice affixes are best characterized as *Subject agreement* (“AV”) (1a), *Object agreement* (“PV”) (1b), *Locative/temporal agreement* (“LV”) (1c), and *Simple topic agreement* (“CV”) (1d).

In the second half of this dissertation, I discuss how the current analysis of the synchronic syntax enables a simpler solution to two major issues in Austronesian diachronic linguistics. Starosta, Pawley, & Reid (1981) have argued that the phenomenon of “*nominalizer-voice affix homophony*” (2a)-(b) observed in many Philippine-type languages arose from an archaic innovation of “*Nominalization-into-verb*,” according to which the historical sources of the synchronic Philippine-type indicative voice affixes PV, LV, and CV (e.g. (2a)) were their functionally corresponding “*nominalizers*”, i.e., Philippine-type voice affixes present in relative clauses (e.g., (2b)):

(2) *Paiwan: Nominalizer-voice affix homophony*

- a. kan-**en** ni kama a vasa. [“voice affix”: -en]
 eat-**PV** GEN father PIVOT taro
 ‘Father ate the taro.’
- b. talagalj aken tua tja kan-**en**. [“nominalizer” -en]
 cook<AV> 1SG.PIVOT ACC 1PL.EXL.POSS eat-“**PT.NMZ**”
 ‘I cooked our {thing to be eaten/food}.’ (ODFL)

According to Ross (2009, 2012) and subsequent work, several higher-order Austronesian languages that synchronically do not show this homophony are the primary-level offshoots of the Austronesian family, which split off from Proto-Austronesian prior to the purported morphosyntactic innovation of “*nominalization-into-verb*”. Kaufman (2009, 2017), on the other hand, has maintained that the homophony between “*nominalizers*” and “*voice affixes*” in Tagalog is the outcome of the languages’ lack of morphological distinction between nouns and verbs. To date, the nature and historical derivation of this homophony remain a point of disagreement.

I argue that the apparent homophony between “*voice affix*” (2a) and “*nominalizer*” (2b) essentially reflects Philippine-type voice morphology present in root clauses and finite relative clauses, respectively, both of which realize topic-agreement within finite CPs. I conclude accordingly that the purported derivational relation between “*nominalizer*” and “*voice affix*” is unmotivated, and that in Philippine-type languages voice-marking affixation is a typical trait of *verbs*.

Building on this analysis, I revisit the recent debate on Austronesian primary-level subgrouping. I show that Philippine-type languages are moving in a common direction of morphological simplification, affecting *root clause morphology* prior to the morphology of subordinate clauses. I argue accordingly that neither the presence of *nominalizer-voice affix homophony* (Ross 2009, 2012; Zeitoun & Teng 2016) nor that of *Philippine-type voice distinctions in root clauses* (Starosta 1995; Aldridge 2016) constitutes a valid criterion for Austronesian primary-level subgrouping, as the presence of both features is a *retention*, rather than a *shared innovation*. I conclude that phonological innovations constitute better criteria for Austronesian primary-level subgrouping than morphological variation. In this view, the Austronesian language family comprises no fewer than ten primary branches, as argued in Blust (1999) (3):

(3) FIGURE 1.1. Austronesian primary-level subgrouping based on phonological evidence

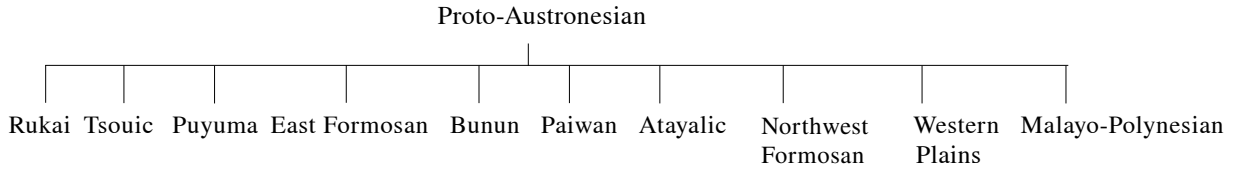

1.2 Outline of the study

This dissertation is made up of six main chapters (Chapters 2–7), each of which investigates a specific aspect of the Philippine-type voice system. In Chapters 2–5, I investigate the synchronic syntax of Philippine-type languages. In Chapters 6–7, I discuss how the analysis of the synchronic syntax developed in Chapters 2–5 motivates a simpler account for two ongoing debates in the literature on Austronesian primary-level subgrouping and on the nature of *nominalizer-voice affix homophony* found in many Philippine-type languages. Below I summarize the main claims of each chapter.

I. Chapter 2: Philippine-type AV clauses ≠ antipassives

In Chapter 2, I examine a longstanding assumption in previous research on Austronesian syntax, that 2-place Actor voice (AV) clauses (4a) in Philippine-type languages are syntactically intransitive, which form a transitivity distinction from Patient voice clauses (4b):

- (4) a. h<um>abol si ivan kay ryan. [Tagalog]
 <AV>chase PN.PIVOT Ivan PN.Y Ryan
 ‘Ivan chased Ryan.’
- b. h<in>abol ni ivan si ryan.
 chase<PV.PRF> PN.X Ivan PN.PIVOT Ryan
 ‘Ivan chased Ryan.’

Drawing on novel comparative evidence from four constructions shared among Philippine-type languages (*productive causatives, raising-to-object constructions, restructuring constructions, and detransitives*), I argue against this assumption from both the perspectives of Case and valency. I first show that the Case assigned to the object of AV clauses (i.e., Y in (4a)) shows the hallmarks of structural accusative Case. I then demonstrate that 2-place AV clauses, which were previously claimed to be antipassive constructions, are compatible with a detransitivizing operation, suggesting that they cannot be syntactically intransitive. I conclude that Philippine-type languages do not exhibit ergativity, as the transitive subject (A) in (4a) patterns with the object (O) in (4b) in both morphological marking and A’-extraction eligibility, suggesting a non-ergative pattern.

II. Chapter 3: “Ergative” = Nominative

In Chapter 3, I investigate the nature of the basic argument-marking X in the Philippine-type voice system, conventionally labeled as ergative/genitive, which falls on the external argument in non-AV clauses (5):

- (5) h<in>abol ni ivan si ryan.
 chase<PV.PRF> PN.X Ivan PN.PIVOT Ryan
 ‘Ivan chased Ryan.’

By scrutinizing the distributional restrictions of X in several basic constructions shared by Philippine-type languages, I demonstrate that X shows typical traits of structural nominative Case, and is incompatible with an inherent ergative Case analysis. I conclude that the basic argument-marking X realizes nominative Case. This analysis, along with the conclusion from Chapter 2, suggests that Philippine-type languages exhibit a nominative-accusative case system.

III. Chapter 4: Pivot ≠ Absolutive/nominative

In Chapter 4, I demonstrate that the morphological marking “Pivot”, whose presence on a phrase suggests that the phrase is eligible to undergo A'-extraction, does not mark structural nominative/ absolutive Case. I first show that the selection of the Pivot in types of constructions in Puyuma, Amis, Seediq, and Tagalog invariably has no effect on the binding relations among arguments in a clause. This suggests that the licensing of “Pivot”-marking does not respect locality, contradicting the prediction of the nominative Case analysis of “Pivot”-marking. I then specify evidence against a high applicative analysis of the Locative and Circumstantial voice affixes, showing that a Pivot in LV/CV clauses may either be a core argument that is structurally low or an adjunct that adjoins to the verb phrase. I conclude that “Pivot”-marking is best analyzed as a marker independent of Case.

IV. Chapter 5: The nature of the Philippine-type voice system

In Chapter 5, I investigate the nature of “Pivot”-marking and Philippine-type voice morphology, and explore their implications for the analysis of the Philippine-type voice system. I first show that “Pivot”-marking is best analyzed as a topic marker that overrides case. I then present a novel account for the four-way division of Philippine-type voice morphology, arguing that it is best analyzed as the morphological realization of four different bundles of Agree relations that agree with the topic (Pivot) of a clause. Under this analysis, the Philippine-type voice affixes AV, PV, LV, and CV are the spell-out of the convergence of topic-agreement with (i) ϕ -agreement (“AV”), (ii) Object-agreement (“PV”), (iii) locative/temporal-agreement (“LV”), and (iv) no agreement (“CV”), respectively. Building on this analysis, I argue that the Philippine-type “Pivot-only” constraint in A'-extraction is in fact not an extraction restriction, but the spell-out of Agree relations that agree with the relativized phrase in a clause, analogous to that with the topic phrase in non-relative clauses. In this view, Philippine-type languages exhibit few constraints in A'-extraction. Following this analysis, I argue that the conventional term “nominalizer” used in the Austronesian literature essentially refers to

Philippine-type voice affixes presented in finite relative clauses, whose nature is the same with those in root clauses. I conclude that Philippine-type languages are best analyzed as hosting a topic-feature at C and a \varnothing -feature at T, with topic-agreement spelled out as verbal morphology.

VI. *Chapter 6: Does morphosyntactic variation among languages constitute reliable evidence for linguistic subgrouping?*

In Chapter 6, I revisit current debates on Austronesian primary-level subgrouping, in particular the question whether phonological innovations or the morphosyntactic variations among higher-order Austronesian languages constitute better evidence for linguistic subgrouping. I first point out that recent proposals using either the presence of *nominalizer-voice affix homophony* (Ross 2009, 2012; Zeitoun & Teng 2016) or that of *Philippine-type voice distinction in root clauses* (Starosta 1995; Aldridge 2016) are built on certain assumptions of the synchronic syntax that have been shown untenable in Chapters 2–5. I then demonstrate that these proposals assume a directionality of change that is essentially arbitrary. Finally, I show that subgroupings derived from these assumptions are in conflict with phonological and lexical evidence for subgrouping, as well as inferences from the archeological record and the sociocultural features of Formosan tribes. I conclude that phonological innovations are more reliable for linguistic subgrouping, given both their internal consistency, and their external compatibility with lexical evidence and inferences from other fields.

VII. *Chapter 7: The nature of Austronesian “nominalizer-voice affix homophony” and its synchronic variations: A new account*

In Chapter 7, I revisit the diachronic origin of “*nominalizer-voice affix homophony*” observed in many Philippine-type languages, which has been used as evidence for subgrouping. I show that the conventional understanding that Philippine-type languages lack a distinction between “nominalizers” and their functionally corresponding indicative “voice affixes” is in fact an illusion created by the terminological distinction between voice affixes in root clauses and those in finite relative clauses. Both realize topic-agreement within finite CPs. Building on this analysis, I conclude that the alleged innovation that gave rise to the apparent homophony is unmotivated. Finally, I argue that the absence of certain features of Philippine-type voice morphology in root clauses in Rukai is better analyzed as a result of independent morphological erosion. I conclude accordingly that the presence of either (i) “nominalizer-voice affix homophony or (ii) Philippine-type voice morphology in root clauses does not constitute evidence for Austronesian primary-level subgrouping.

VIII. *Chapter 8: Conclusion*

In Chapter 8, I summarize the main claims of Chapters 2-7, and discuss remaining questions and future directions of the study of the Philippine-type voice system.

1.3 What is a Philippine-type voice system?

In this section, I provide a brief background of Philippine-type languages, and outline basic traits of the Philippine-type voice system.

The term *Philippine-type voice (focus) system*, also known as the *Austronesian-type voice (focus) system*, refers to a typologically unusual grammatical system found primarily in Austronesian languages that are geographically closer to the homeland, Taiwan. This includes the majority of indigenous languages spoken in Taiwan, the Philippines, northern Borneo, and northern Sulawesi, as well as Malagasy and Chamorro. Given its presence in nine of the ten Austronesian primary branches, this grammatical system is uncontroversially reconstructable to Proto-Austronesian (see, e.g., Wolff 1973; Ross 2006, 2009, 2012; Blust 2015; Blust & Chen 2017).

A Philippine-type voice system is characterized by four sets of affixal morphology on the verb that correlate with the argument-marking pattern and A'-extraction restriction in a clause. These affixes are conventionally called *voice/focus affixes*.¹ The core traits of this system are summarized in (6):

(6) *Typical traits of the Philippine-type voice system*

- a. In every clause, there is one and only one phrase that can be A'-extracted, conventionally called the *Pivot*. This syntactically pivotal phrase bears a specific morphological marking (henceforth "Pivot"-marking) regardless of its thematic role and grammatical relation.
- b. The selection of the Pivot is indicated by affixal morphology on the main verb within a CP, conventionally called *voice morphology*. In morphologically conservative languages, Philippine-type voice morphology inflects for both the selection of the Pivot and mood.
- c. When a phrase is non-Pivot-marked, it carries a fixed argument marking.

The four sets of voice morphology are conventionally called *Actor voice (AV)*, *Patient voice (PV)*, *Locative voice (LV)*, and *Circumstantial voice (CV)*, with names which indicate the best known function of the affix.² The argument-marking pattern in clauses for each voice is illustrated with the Paiwan and Tagalog data (7)-(8). As seen below, when the same sentence is marked in AV, PV, LV, and CV, Pivot-marking falls on the *external argument* 'man'/'the child' ((7a), (8a), the *internal argument* 'boar'/'cloth' ((7b), (8b)), the *locative/source phrase* 'the mountains'/'the shopkeeper' ((7c), (8c)), and the *instrumental phrase* 'a spear' (7d) or the *benefactive phrase* 'mother' (8d), respectively:

¹ A number of Philippine-type languages employ a word order restriction that correlates with the verbal morphology, such as Malagasy, Atayal, and Seediq. The word order variation among Philippine-type languages is discussed in Chapter 4.

² The Circumstantial voice is also referred to as the Conveyance voice or the Instrumental voice.

(7) *Paiwan*

- a. q<m>alup a caucau tua vavuy i gadu tua vuluq. [AV]
 <AV>hunt PIVOT man Y pig LOC mountain Y spear
 ‘The man hunts wild pigs in the mountains with a spear.’
- b. qalup-en nua caucau a vavuy i gadu tua vuluq. [PV]
 hunt-PV X man PIVOT pig LOC mountain Y spear
 ‘The man hunts *wild pigs* in the mountains with a spear.’
- c. qalup-an nua caucau tua vavuy a gadu tua vuluq. [LV]
 hunt-LV X man Y pig PIVOT mountain Y spear
 ‘The man hunts wild pigs *in the mountains* with a spear.’
- d. si-qalup nua caucau tua vavuy i gadu a vuluq. [CV]
 CV-hunt X man Y pig LOC mountain PIVOT spear
 ‘The man hunts wild pigs in the mountains *with a spear.*’ (Ferrell 1979:202)

(8) *Tagalog*

- a. b<um>ili si ivan ng keyk mula kay viktoría para kay amber. [AV]
 <AV>buy PN.PIVOT Ivan ID.Y cake from PN.Y Victoria P DF.Y Amber
 ‘Ivan bought cake from Victoria for Amber.’
- b. bi-bilih-in ni ivan ang keyk mula kay viktoría para kay amber. [PV]
 CONT-buy-PV PN.X Ivan PIVOT cake from PN.Y Victoria P PN.Y Amber
 ‘Ivan will buy *the cake* from Victoria for Amber.’
- c. bi-bilh-an ni ivan ng keyk si viktoría para kay amber. [LV]
 CONT-buy-LV PN.X Ivan ID.Y cake PN.PIVOT Victoria P PN.Y Amber
 ‘Ivan will buy cake *from Victoria* for Amber.’
- d. i³-bi-bili ni ivan ng keyk mula kay viktoría si amber. [CV]
 CV-CONT-buy PN.X Ivan ID.Y cake from PN.Y Victoria PN.PIVOT Amber
 ‘Ivan will buy cake from Victoria *for Amber.*’

As can also be seen above, when an external argument is non-Pivot-marked, it carries a fixed morphological marking, X. When an internal argument is non-Pivot-marked, it carries a fixed morphological marking, Y. When a locative phrase is non-Pivot-marked, it receives a specific type of preposition conventionally labeled as a locative marker. When an Instrument or Benefactor is non-Pivot-marked, it is either accompanied by Y alone (7a-c) or by a specific type of preposition that precedes Y (8a-c).⁴ This basic argument-marking mechanism is shared across Philippine-type languages, summarized in (9). The parentheses in the table indicate that the presence of the corresponding phrase is optional:

³ Tagalog *i-* < Proto-Austronesian CV affix *Si-.

⁴ The labels Pivot, X, and Y correspond to the conventional labels Nominative/Absolutive, Genitive/Ergative, and Oblique, respectively.

(9) TABLE 1.1. Basic argument-marking pattern in Philippine-type languages⁵

	Actor voice	Patient voice	Locative voice	Circumstantial voice
External argument	Pivot	X	X	X
Internal argument	(Y)	Pivot	(Y)	(Y)
Location	(Loc)	(Loc)	Pivot	(Loc)
Instrument/benefactor	(Y/P-Y)	(Y/P-Y)	(Y/P-Y)	Pivot

In morphosyntactically conservative languages, the Philippine-type voice morphology inflects for at least three types of mood (10a)-(c). This three-way distinction can be traced back to Proto-Austronesian. The indicative sentences presented in (7)-(8) contain reflexes of the indicative affixes: AV *<um> (10a), PV *-en (10b), LV *-an (10c), and CV *Si-/Sa- (10d).

(10) TABLE 1.2. Prototypical Philippine-type voice morphology

	Actor voice	Patient voice	Locative voice	Circumstantial voice
a. indicative	*<um>	*-en	*-an	*Si-/Sa-
b. optative, hortative	*-a	*-aw	*-ay	*-anay
c. imperative, negative	*-Ø	*-u	*-i	*-an

Across Philippine-type languages, the mapping between the selection of the Pivot and the corresponding voice-marking in various types of basic constructions is highly stable. This mapping is summarized in (11):

(11) TABLE 1.3. The shared pattern in Pivot-selection in Philippine-type languages

a. AV	<i>Agent (in unergatives or 2-place clauses), Theme (in unaccusatives), Causer (in causatives), Experiencer (in statives)</i>
b. PV	<i>Theme (in transitives), Causee (in causatives), Recipient (in ditransitives)</i>
c. LV	<i>Location, Source, Goal, Temporal expression, Event (gerundives)</i>
d. CV	<i>Instrument, Benefactor, Theme of the caused event (in causatives), Theme (in ditransitives), Reason, Causee, Stimulus, Arouser, Manner, Degree, Purpose</i>

This mapping between Pivot-selection and voice-marking is consistently observed in both root clauses and relative clauses. The latter includes the presupposed clause in pseudo-clefts and nominals formed by a headless relative clause. As the voice morphology present in relative clauses is conventionally called “nominalizers”, the apparent homophony between root-clause and relative-

⁵ See Appendix IV for a more detailed discussion of the prototypical argument-marking pattern of Philippine-type languages.

clause morphology is commonly called *nominalizer-voice affix homophony* (Starosta, Pawley, & Reid 1981; Ross 2009, 2012), as in (12a)-(b):

(12) *Seediq: Nominalizer-voice affix homophony*

- | | |
|--|--|
| <p>a. wada puq-un na robo ka rodux di.
 PRF eat-PV X Robo PIVOT chicken PART
 ‘Robo already ate chicken.’</p> | <p>[verbal environment]</p> |
| <p>b. rodux [RC wada puq-un na robo]
 chicken [RC PRF eat-PT.NMZ X Robo]
 ‘chicken that Robo already ate’</p> | <p>[relative clause]</p> |
| <p>c. maanu ka [wada puq-un na robo]?
 what PIVOT [PRF eat-PT.NMZ X Robo]
 ‘What was the thing that Robo already ate?’</p> | <p>[presupposed clause of cleft]</p> |
| <p>d. puq-un
 eat-PT.NMZ
 ‘thing that will be eaten; food’</p> | <p>[nominal formed by
 a headless relative clause]</p> |

This study investigates the following questions (13a)-(d) that revolve around the nature of the Philippine-type voice system:

(13) *Core questions to be explored in this dissertation*

- a. What is the nature of Pivot, X, and Y?
- b. What is the nature of the mechanism involved in the argument-marking alternation in (9)?
- c. What is the nature of the four-way division of the Philippine-type voice morphology?
- d. What is the nature and the historical origin of the homophony between “voice affixes” and “nominalizers” (12a)-(d)?

1.4 Methodology and a note on the target languages

In this section, I discuss the core methodology adopted in this dissertation. In 1.4.1, I outline the Comparative Method, which will be adopted throughout this study. In 1.4.2, I discuss the motivation of the choice of the four target languages, Puyuma, Amis, Seediq, and Tagalog. In 1.4.3, I provide an introduction of these four languages.

1.4.1 Methodology

In this study, I apply the Comparative Method to identify the core syntactic traits of the Philippine-type voice system. The Comparative Method is a standard methodology in historical comparative linguistics. Its principle is introduced below:

If a feature X is present in the majority of primary branches of a language family, as in (14), it is more parsimonious to assume that X was also present in the immediate ancestor of these languages, namely Proto-ABCDEFGHIJ, rather than to assume that it emerged independently in each of the eight branches, A, B, C, D, E, F, G, and H. This treatment is known as the *Majority Rule*, which follows Occam’s Razor. The logic behind this treatment goes as follows: assuming the presence of X at Proto-ABCDEFGHIJ requires only two innovations to derive the synchronic absence of the feature X in Branches I and J; alternatively, assuming X to have not existed in Proto-ABCDEFGHIJ requires eight independent innovations to derive the presence of X in each of the eight branches A, B, C, D, E, G, G, and H. The former assumption is optimal, as it is more parsimonious.

(14) *The Comparative Method and the Economy Principle*

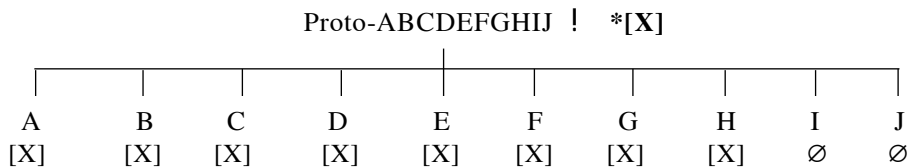

This dissertation applies this principle to identify the core syntactic traits of the Philippine-type languages. Specifically, if a morphosyntactic pattern X is consistently observed in Philippine-type languages under multiple Austronesian primary branches, I assume it to be prototypical feature of the Philippine-type voice system. For instance, in languages under nine of the ten Austronesian primary branches, productive causative constructions share the following argument-marking pattern (15), with little variation attested:

(15) *TABLE 1.4. The shared argument-marking pattern in productive causatives*

	a. Actor voice	b. Patient voice	c. Circumstantial voice
Causer	Pivot	X	X
Causee	Y	Pivot	Y
Causand	Y	Y	Pivot

As shown above, when a causative sentence is marked in AV, PV, and CV, the morphological marking “Pivot” falls on the Causer, Causee, and Causand, respectively. Since this pattern is observed across nine of the ten Austronesian primary branches (and its absence in Rukai is due to the language’s lack of a Philippine-type voice system), I consider this argument-marking pattern as

morphologically encoding the core syntax of the Philippine-type voice system. As will be seen in Chapters 2–5, Philippine-type languages in fact show very little variation in their argument-marking pattern in types of basic constructions. The core characteristics of this voice system are therefore straightforward to identify.

1.4.2 A note on Formosan languages

The core data used in this dissertation comes from primary fieldwork on four Philippine-type Austronesian languages: Puyuma, Amis, Seediq, and Tagalog. Although three of these four languages are situated in Taiwan, each of the four languages belongs to a different Austronesian primary branch. Given the *Economy Principle* introduced in 1.4.1, the shared syntactic traits of these four languages can be identified as prototypical of the Philippine-type voice system. In this subsection, I provide an overview of the internal classification of the Austronesian language family and discuss why Formosan languages, i.e., Austronesian languages spoken in Taiwan, are particularly informative for the study of the Philippine-type voice system.

There has been a consensus in the literature that Austronesian languages spoken in the homeland, Taiwan, constitute the majority of Austronesian primary branches (see, e.g., Tsuchida 1976; Blust 1977, 1999; Ho 1998; Sagart 2004, 2008; Ross 2009, 2012).⁶ Under the standard subgrouping based on phonological innovations (Blust 1999), the Austronesian family comprises ten primary branches, nine of which are situated in Taiwan (16). The four target languages investigated in this study are marked with an asterisk.

(16) FIGURE 1.2. The positions of Formosan languages in the Austronesian language family

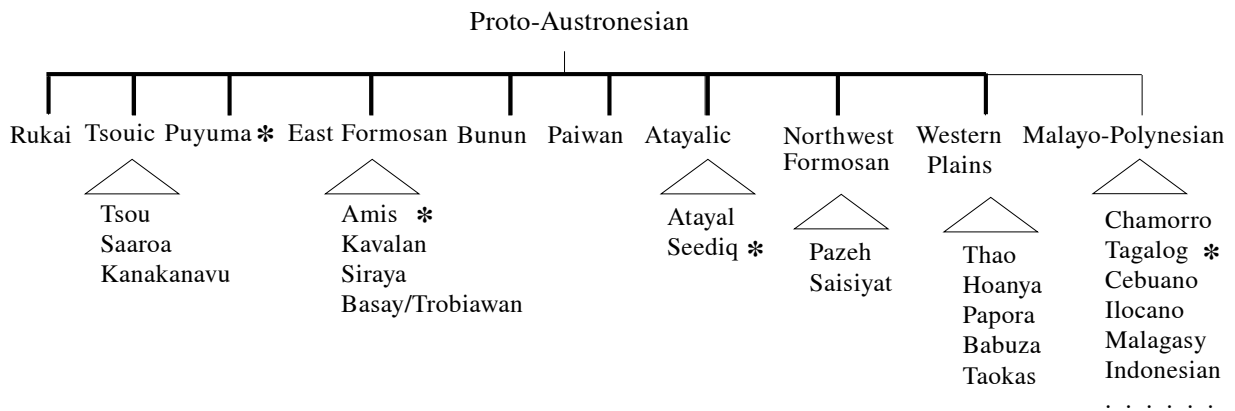

The Philippine-type languages spoken in Taiwan are morphosyntactically highly conservative, as noted by Dahl (1981): “the Formosan languages are so archaic both in phoneme inventory and grammatical forms that they to a certain degree constitute a ‘museum’ preserving old Austronesian

⁶ See Chapter 6 for further details.

material.” As these understudied languages preserve rich grammatical features unattested in most Philippine-type languages spoken outside Taiwan, this study relies much on the comparative evidence from data from the three Formosan languages Puyuma, Amis, Seediq, and their consistency with the Malayo-Polynesian language Tagalog.

1.4.3 Background of the target languages: Puyuma, Amis, Seediq, and Tagalog

In this subsection, I provide a brief background of the four target languages in this study.

1.4.3.1 Language backgrounds

Puyuma, Amis, and Seediq are three Formosan languages spoken in central and southeastern parts of Taiwan. Tagalog is the official language of the Philippines. The speaker populations and basic information about the four languages are summarized in (17). The geographical distribution of the four languages is illustrated in (18):

(17) TABLE 1.5. Backgrounds of Puyuma, Amis, Seediq, Tagalog⁷

	Puyuma	Amis	Seediq	Tagalog
a. Ethnic population	8,490	30,000	20,000	28,000,000 (L1)
b. Number of speakers	1,500	13,800	4,750	35,000,000 (L1/2)
c. Endangerment level	Severe	Definitive	Definitive	No

(18) FIGURE 1.3. The geographical location of Puyuma, Amis, Seediq, and Tagalog

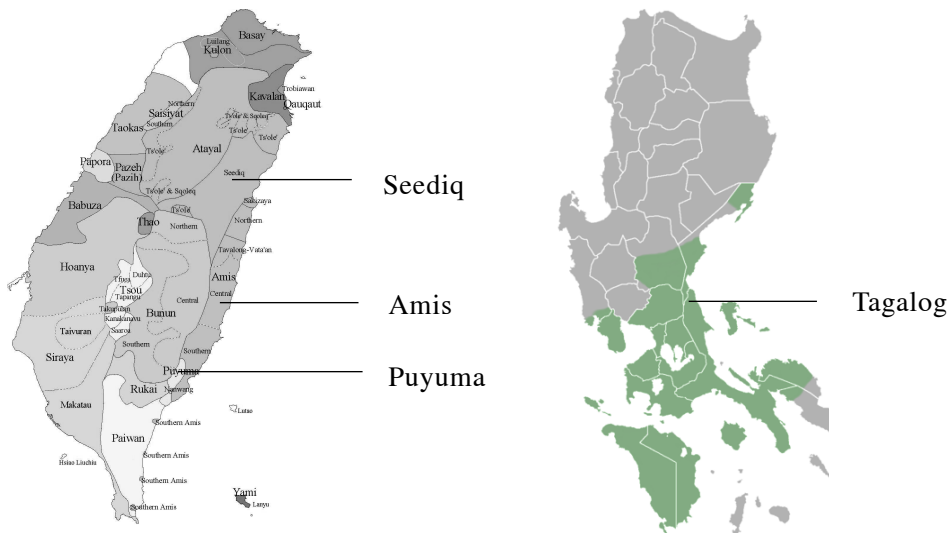

⁷ Sources: Ethnologue (www.ethnologue.com), the UNESCO Atlas of the World’s Languages in Danger (www.unesco.org/culture/language-atlas), and the Endangered Languages Project (www.endangeredlanguages.com).

Below I provide a brief introduction of the four languages.

Puyuma. Puyuma is a severely endangered language spoken in southeastern Taiwan (Taitung County), and is commonly considered a single-member primary branch of the Austronesian family (Blust 1999; Ross 2009). The data used in this study were collected from the Nanwang and Pinaski dialects (Taitung City, Taitung) during 2013–2017 with four speakers over age 65.

Amis. Amis is spoken in the east coast of Taiwan across Hualien and Taitung Counties. It is a member of the East Formosan primary branch of the Austronesian language family. The data used in this study were collected during 2014–2017 from the Central dialect of Amis spoken in Ningpu, Changpin Township, Taitung, with three native speakers over age 65.

Seediq. Seediq is spoken in central Taiwan across Nantou and Hualien Counties. This study includes data collected from both Tgdaya (Puli, Nantou) and Truku (Fusji, Hualien) dialects during 2012–2017 with five speakers over age 60. As the Tgdaya dialect is morphologically more conservative and preserves an X/Y distinction in its argument-marking system, it is the main source of the Seediq data used in this study.

Tagalog. Tagalog is spoken as a first language by a quarter of the population of the Philippines and as a second language by the majority. The data presented in this study were collected from two speakers from Manila during 2016–2017, who speak the Metro Manila dialect of Tagalog.

1.4.3.2 Basic morphosyntax of Puyuma, Amis, Seediq, and Tagalog

Puyuma, Amis, Seediq, and Tagalog all exhibit a typical Philippine-type voice system. Each of the four languages exhibits a four-way voice distinction in verbal morphology and the “Pivot-only” constraint in A’-extraction. Below I outline the basic morphosyntax of the four languages in terms of voice morphology, argument-marking system, and word order.

Voice morphology. Table (19) summarizes the common voice affixes in Puyuma, Amis, Seediq, and Tagalog:

(19) TABLE 1.6: Indicative voice morphology of Puyuma, Amis, Seediq, and Tagalog

	a. Actor voice	b. Patient voice	c. Locative voice	d. Circumstantial voice
a. Puyuma ⁸	, ma-, me-, m-	-aw	-ay	-anay
b. Amis	<um>, ma-, mi-	-en	-an	sa-
c. Seediq	<m>, m-	-un	-an	s-
d. Tagalog	<um>, mag, ma-, mang-	-in	-an	i-
Proto-form	*-um-	*-en	*-an	*Si-/Sa-

⁸ See Chapters 6–7 for a discussion of the peculiar voice morphology of Puyuma.

Argument-marking system. All four languages exhibit a three-way argument marking system that distinguish among Pivot, X, Y, summarized in (20a)-(d). Note that in the Nanwang dialect of Puyuma (20a) and Tagalog (20d), the morphological distinction between X and Y has been lost in part of their argument-marking paradigm (i.e., the common noun-marking):⁹

(20) TABLE 1.7: Some argument-marking patterns of the target languages¹⁰

a.	Common noun	Personal name	1st singular	2nd singular	3rd singular	[N. Puyuma]
Pivot	<i>a</i> _(ID) , <i>na</i> _(DF)	<i>i</i> (sg.)	= <i>ku</i>	= <i>yu</i>	—	
X	<i>dra</i> _(ID) , <i>kana</i> _(DF)	<i>kan</i> (sg.)	<i>ku</i> =	<i>nu</i> =	<i>tu</i> =	
Y	<i>dra</i> _(ID) , <i>kana</i> _(DF)	<i>kan</i> (sg.)	<i>kanku</i>	<i>kanu</i>	<i>kantu</i>	
b.	Common noun	Personal name	1st singular	2nd singular	3rd singular	[C. Amis]
Pivot	<i>ku</i>	<i>ci</i> (sg.)	<i>kaku</i>	<i>kisu</i>	<i>cingra</i>	
X	<i>nu</i>	<i>ni</i> (sg.)	<i>aku</i>	<i>isu</i>	<i>nira</i>	
Y	<i>tu</i>	<i>ci</i> -...- <i>an</i> (sg.)	<i>takuwanan</i>	<i>tisuwanan</i>	<i>cingranan</i>	
c.	Common noun	Personal name	1st singular	2nd singular	3rd singular	[D. Seediq]
Pivot	<i>ka</i>	<i>ka</i>	= <i>ku</i>	= <i>su</i>	—	
X	<i>na</i>	<i>na</i>	= <i>mu</i>	= <i>su</i>	= <i>na</i>	
Y	∅	∅	<i>yaku</i>	<i>isu</i>	<i>heya</i>	
d.	Common noun	Personal name	1st singular	2nd singular	3rd singular	[Tagalog]
Pivot	<i>ang</i>	<i>si</i>	= <i>ako</i>	= <i>ikaw</i>	= <i>siya</i>	
X	<i>ng</i>	<i>ni</i>	= <i>ko</i>	= <i>mo</i>	= <i>niya</i>	
Y	<i>ng</i> _(ID) , <i>sa</i> _(DF)	<i>kay</i>	<i>sa akin</i>	<i>sa iyo</i>	<i>sa kanya</i>	

Nevertheless, a distinction between X and Y is still manifested in Nanwang Puyuma, evidenced by the presence or absence of the proclitic. As seen in the data below in (21a)-(b), the external argument (i.e., X-marked phrases) is obligatorily expressed as a proclitic *ku*= (1st person), *nu*= (2nd person), or *tu*= (3rd person), which cross-references the *kan/kana*-marked phrase in the sentence; when *kan/kana* marks a Y-phrase, the phrase is not (and cannot be) cross-referenced by a proclitic. Therefore, in Puyuma, an X/Y distinction is still present.

(21) The presence of an X/Y distinction in Puyuma argument-marking pattern

- a. tu_i=trima-aw **kan** senten_i na aputr.
3.X_i=buy-PV **SG.X** Senten_i DF.PIVOT flower
 ‘Senten bought the flowers.’

⁹ Note that in more conservative Puyuma dialects, an X/Y distinction is still present in common noun and personal name marking. See Teng (2009) for details.

¹⁰ Sources: Nanwang Puyuma: Teng (2008); Central Amis (Wu 2006); Tgdaya Seediq (primary data); Tagalog (McFarland 1976). More details of the prototypical argument-marking pattern of Philippine-type languages can be found in Appendix IV.

- b. $\langle \text{AV} \rangle$ aletra' i siber **kan** senten.
 slap $\langle \text{AV} \rangle$ SG.PIVOT Siber **SG.Y** Senten
 'Siber slapped Senten.'

In Tagalog, on the other hand, the argument-marking for non-Pivot external arguments and non-Pivot internal arguments is distinguished only in personal name or pronominal marking, but not in common noun marking. This is seen in (22a)-(b), where the common-noun internal argument 'adobo' in (22a) shares the same marker *ng* with the common-noun external argument 'the child' in (22b). See Appendix IV for a detailed discussion of the prototypical argument-marking pattern of Philippine-type languages.

(22) *The presence of an X/Y distinction in Tagalog*

- a. nag-luto {si ivan/ang bata/siya} **ng** adobo.
 AV.PRF-cook {PN.PIVOT Ivan/PIVOT child/3SG.PIVOT} **ID.Y** adobo
 '{Ivan/the child/he/she} cooked adobo.'
- b. ni-luto {**ni** ivan/**ng** bata/**niya**} ang adobo.
 PRF.PV-cook {**PN.X** Ivan/(CN.)**X** child/3SG.**X**} PIVOT adobo
 '{Ivan/the child/he/she} cooked the adobo.'

To make the X/Y distinction explicit, the Tagalog data presented in this study all contain a personal name as the external argument.

Finally, it is noteworthy that both Tagalog and Puyuma exhibit definiteness distinction in object marking. This is illustrated with the data in (23a)-(b):

(23) *Definiteness distinction in object-marking in Tagalog and Puyuma*

- a. sagar i atrung {**dra/kana** aputr}. [Puyuma]
 like.AV PN.PIVOT Atrung {**ID.Y/DF.Y** flower}
 'Atrung likes {flowers/the flowers}.'
- b. $\langle \text{AV} \rangle$ abol si ivan {**ng/sa** tao}. [Tagalog]
 chase $\langle \text{AV} \rangle$ PN.PIVOT Ivan {**ID.Y/DF.Y** person}
 'Ivan chased {a/the person}.'

Word order. Most Philippine-type Austronesian languages are predicate-initial. These languages exhibit three major types of word order in terms of the ordering among nominals (24a)-(c):¹¹

¹¹ Here, I have excluded the cases of SVO languages, which is generally agreed to be a secondary innovation either by language contact or independent changes.

(24) *Three types of (predicate-initial) word order variation in Philippine-type languages*

- a. *Pivot-final* (V- non-Pivots - Pivot), e.g., Malagasy, Seediq, Atayal, Tsou, Pazeh
- b. *Thematic hierarchy* (V - Agent - Theme - X), e.g., Amis, Tagalog
- c. *Flexible* (V - flexible), e.g., Puyuma, Paiwan

The first language type requires the Pivot phrase to appear in the sentence-final position regardless of its thematic role. This includes Seediq, Malagasy, Atayal, Tsou, and Pazeh. See the Seediq examples (25):

(25) *Pivot-final word order in Seediq*

- a. s<m><n>eeliq Ø babuy **ka** **dakis.** [Actor voice]
 <AV><PRF>butcher Y boar **PIVOT** **Dakis**
 ‘Dakis butchered a/the boar.’
- b. s-seeliq-un na dakis **ka** **babuy.** [Patient voice]
 RED-butcher-PV X Dakis **PIVOT** **boar**
 ‘Dakis will butcher the boar.’

The second language type requires its nominal phrases to follow the thematic hierarchy *Agent-Theme-the rest*, regardless of the voice type of the sentence. The word order of Amis strictly follows this hierarchy (Wu 2006; primary data), as seen in (26):

(26) *Word order in Amis*

- a. mi-qaca’ [kaku] [tu pawli] [i lumaq ni sawmah]. [Actor voice]
 AV-buy [1SG.PIVOT] [Y banana] [LOC house POSS Sawmah]
 ‘I bought bananas at Sawmah’s house.’
- b. pi-qaca-an¹² [aku] [tu pawli] [ku lumaq ni sawmah]. [Locative voice]
 buy-LV [1SG.X] [Y banana] [PIVOT house POSS Sawmah]
 ‘I bought bananas at Sawmah’s house.’

The Tagalog data presented in this study also exhibits this word order. See examples (27a)-(b):

(27) *The preferred word order in Tagalog*

- a. k<um>anta **si** **ivan** ng kanta sa parke. [Actor voice]
 <AV>sing **PN.PIVOT** **Ivan** ID.Y song LOC park
 ‘Ivan sang a song at the park.’
- b. k<in>anta ni ivan **ang** **kanta** sa parke. [Patient voice]
 sing<PV.PRF> PN.X Ivan **PIVOT** **song** LOC park
 ‘Ivan sang a song at the park.’

¹² In Amis, the Locative voice affix has the form *pi-* ... *-an* for 2-place verbs. See Wu (2006) for details.

A third language type allows flexible word order between nominals, as in Puyuma (Teng 2009) and Paiwan (H. Chang 2006). In the following Puyuma sentences, the order between the nominals is freely interchangeable:

(28) *Flexible word order in Puyuma*

- a. senay {kana senay} {i **senten**}. [Actor voice]
 <AV>sing {ID.Y song} {PN.PIVOT **Senten**}
 ‘Senten sang a song.’
- b. tu=senay-aw {na **senay**} {kan senten}. [Patient voice]
 3.X=sing-PV {DF.PIVOT **song**} {PN.Y Senten}
 ‘Senten sang a song.’

As such, the three target languages of this dissertation, Puyuma, Amis, and Seediq, each belong to a different type.

1.4.4 Other languages surveyed in this study

Besides primary data from Puyuma, Amis, Seediq, Tagalog, in identifying the shared argument-marking pattern in types of basic constructions among Philippine-type languages I also survey a number of Philippine-type languages. A list of sample languages and their subgrouping affiliations is given in (29):

(29) *Philippine-type languages (under each of the 10 primary branches) surveyed in this study*

1. Atayalic: Atayal, Seediq
2. Bunun: Bunun
3. East Formosan: Amis, Kavalan, Basay, Siraya
4. Northwestern Formosan: Pazeh, Saisiyat
5. Paiwan: Paiwan
6. Rukai: Rukai
7. Puyuma: Puyuma
8. Western Plain: Thao
9. Tsouic: Tsou, Saaroa, Kanakanavu
10. Malayo-Polynesian: Yami, Ilocano, Blaan, Bikol, Cebuano, Botolan Sambal, Malagasy, Subanon, Kimaragang Dusun, Toba Batak, Tagalog, Chamorro

1.5 Theoretical assumptions

This dissertation adopts the framework of the Minimalist Program (Chomsky 1995, 2000, 2001 and thereafter) in the analyses of types of basic constructions of Philippine-type Austronesian languages. Below I outline the core assumptions adopted in this study.

1.5.1 Agree and Merge

Following Chomsky (1995, 2001a), I assume that all instances of movement are the output of *Merge*, accompanied by a relation of feature checking/valuation, i.e., *Agree*. Under this assumption, a feature F must find the (closest) phrase bearing the same feature F. Once the Agree relation is established between F and the phrase that bears the same feature, the phrase would merge to the specifier of the head that hosts F, as in (30):

(30) *Agree and Merge*

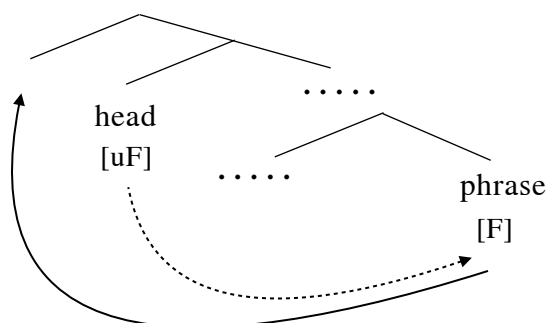

1. *Agree* (dotted line): the feature F targets the closest phrase that bears an [F]-feature
2. *Merge* (solid line): the phrase moves to the specifier of the head that hosts F

1.5.2 The division of Voice and ν

In this study, I adopt a recent proposal within the Minimalist Program, that the functional projection of verb phrase divides into at least two layers, *Voice* and ν , as in (31) (e.g., Kratzer 1996; Pylkkänen 2002; Alexiadou et al. 2006; Schäfer 2008; Harley 2013; Legate 2014). Following these works, I assume that *Voice* is the higher projection of the two, responsible for introducing an external argument, as well as the licensing of structural accusative Case or inherent ergative Case. It is also the locus of *voice* (e.g., active versus passive). ν is the lower projection of the two, which verbalizes the root and introduces causative semantics. In the diagrams below, the abbreviations “EA” and “IA” stand for external argument and internal argument, respectively.

(31) *The division of Voice and v*

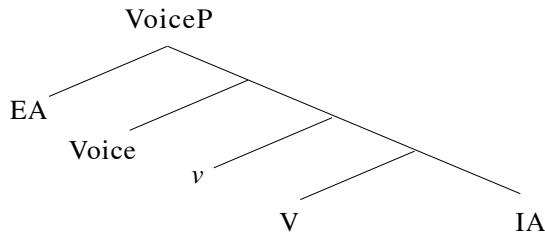

In earlier work that does not adopt this division, the functional divisions of Voice and *v* were not assumed, and all these functions were expressed by *v*. Therefore, the use of “Voice” in this dissertation corresponds to the notion “*v*” used in several important works on Philippine-type languages, including Richards (2000), Pearson (2001, 2005), and Aldridge (2004, 2008, 2012), which do not adopt the division of Voice and *v*.

1.5.3 Case and Case-licensing

This study adopts the standard assumption of case theory within the Minimalist Program (e.g., Marantz 1993; Bobaljik 1998; Woolford 2006). I assume that abstract Case divides into structural Case and nonstructural Case. Structural Cases are licensed in a purely structural way, whereas non-structural Cases are licensed in connection with theta-licensing.

Nonstructural Case further subdivides into inherent Case and lexical Case. Inherent Case involves predictability, whereas lexical Case involves the θ -positions with which each can be associated. This is illustrated in (32):

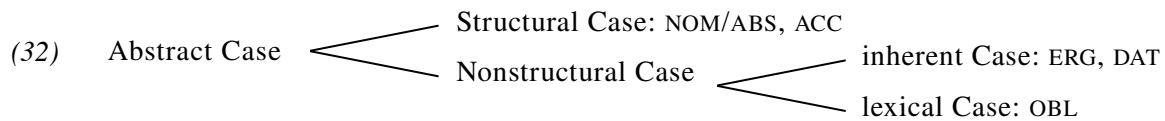

Under this division, nominative/absolute Case and accusative Case are structural Cases licensed by C/T and Voice⁰, respectively, as in (33)-(34):

(33) *Nominative/absolute Case-licensing*

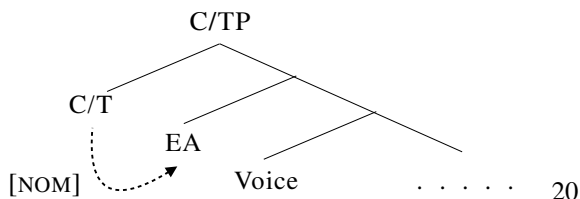

(34) *Accusative Case-licensing*

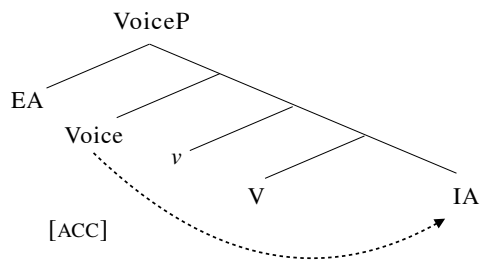

Ergative Case is a type of inherent Case assigned by Voice to the external argument in Head-Spec relation, as in (35):

(35) *Ergative Case-licensing*

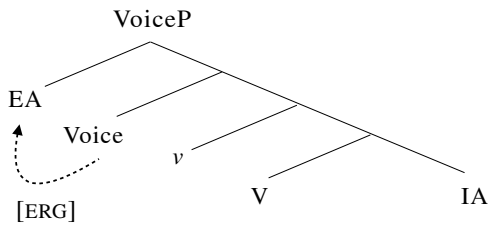

Oblique Case is a lexical Case assigned by the lexical verb (V) in Head-Comp relation to the internal argument. Following the standard assumption (Chomsky 1981, 1986; Maling 2002; Woolford 2006), I assume that the licensing of oblique Case is accompanied by theta-role assignment, as in (36):

(36) *Oblique Case-licensing*

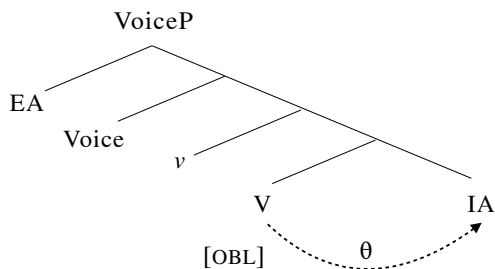

1.5.4 Distributed morphology

In this dissertation, I also assume the framework of *Distributed Morphology* (Halle & Marantz 1993, 1994). The central notion of this hypothesis is that morphology is a part of the mapping from the output of a syntactic derivation to the input of the phonology, as in (37):

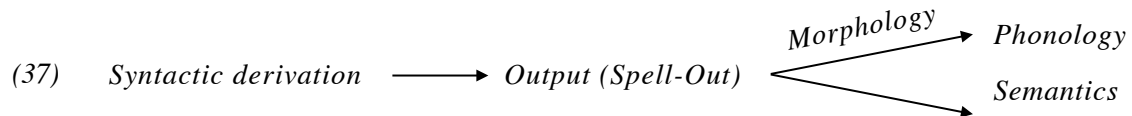

The most important aspect of Distributed Morphology adopted in this study is *Late Insertion* (Halle & Marantz 1993, 1994; Halle 1990; Noyer 1997), which refers to the assumption that the phonological expression of syntactic terminals is in all cases provided in the mapping to Phonological Form. Following this notion, I assume that only after syntax are phonological expressions inserted. This process is called *spell-out*.

Chapter 2

Reconsidering Philippine-type Actor voice

Previous research in Austronesian syntax commonly assumes that Actor voice (AV) and Patient voice (PV) clauses in Philippine-type languages are distinguished by transitivity. Under this assumption, Philippine-type languages manifest syntactic ergativity, as the alleged intransitive subjects in AV clauses pattern with transitive objects in PV clauses in both argument marking and A'-extraction accessibility.

In this chapter, I lay out two arguments against this assumption by demonstrating that 2-place AV clauses are true transitives from the perspective of both Case and valency. I first show that the distribution of the marker on the objects of AV clauses (Y) shows the hallmarks of structural accusative Case. I then demonstrate that 2-place AV clauses in four distantly related languages are compatible with essentially the same detransitivizing operation, suggesting that 2-place AV constructions cannot be syntactically intransitive. I conclude that Philippine-type AV and PV clauses are not distinguished by transitivity, as 2-place AV clauses are transitives, rather than antipassives. This conclusion undermines a syntactic ergative approach to Philippine-type languages, and calls for a reconsideration of the nature of Philippine-type “voices”.

2.1 Introduction

I begin this study by investigating a question fundamental to understanding the nature of the Philippine-type voice system:

- (1) What is the nature of the distinction between Philippine-type Actor voice (AV) and Patient voice (PV) clauses?

The pair of Tagalog sentences below exemplifies typical AV (2a) and PV (2b) patterns:

- (2) a. **nang**-kurot si amber kay viktoría. [Tagalog]
AV.PRF-pinch PN.PIVOT Amber PN.Y Victoria
'Amber pinched Victoria.'
- b. k<in>urot ni amber si viktoría.
<PV.PRF>pinch PN.X Amber PN.PIVOT Victoria
'Amber pinched Victoria.'

Specifically, I examine a common assumption in the Austronesian literature that has major implications for the analysis of the Philippine-type voice system:

- (3) In Philippine-type languages, AV clauses are syntactically intransitive, as opposed to PV clauses, which are basic transitives.

To approach the empirical facts behind this assumption, I will first introduce the basic argument-marking pattern in Philippine-type languages.

Consider the data below from two typical Philippine-type languages, Seediq and Tagalog. To remain theory-neutral, the data are glossed with the abstract labels Pivot, X, and Y. The label Pivot indicates that a phrase is accessible to A'-extraction. The labels X and Y are conventionally labeled as "Ergative/Genitive" and "Oblique", respectively.

(4) Seediq

- a. wada k<m>eeki ka pawan di. [Actor voice: 1-place]
 PRF <AV>dance PIVOT Pawan PART
 'Pawan danced.'
- b. wada m-huqil/*-un ka pawan di. [Actor voice: 1-place]
 PRF AV-die/*-PV PIVOT Pawan PART
 'Pawan passed away.'
- c. wada h<m>anguc ∅ wawa ka pawan. [Actor voice: 2-place]
 PRF <AV>cook Y meat PIVOT Pawan
 'Pawan cooked the meat.'
- d. wada hanguc-un na pawan ka wawa. [Patient voice: 2-place]
 PRF cook-PV X Pawan PIVOT meat
 'Pawan cooked the meat.'

(5) Tagalog

- a. k<um>anta si ivan. [Actor voice: 1-place]
 <AV>sing PN.PIVOT Ivan
 'Ivan sang.'
- b. l<um>ubog/*<in> si ivan. [Actor voice: 1-place]
 <AV>sink/*PV.PRF PN.PIVOT Ivan
 'Ivan sank.'
- c. b<um>asa si ivan ng diyaryo. [Actor voice: 2-place]
 <AV>read PN.PIVOT Ivan ID.Y newspaper
 'Ivan read a newspaper.'
- d. b<in>asa ni ivan ang diyaryo. [Patient voice: 2-place]
 read<PV.PRF> PN.X Ivan PIVOT newspaper
 'Ivan read the newspaper.'

In both languages, an Actor voice (AV) affix can combine with either 1-place or 2-place verbs ((4a)-(c), (5a)-(c)). However, a Patient voice (PV) affix can only combine with 2-place verbs ((4d), (5d)). Even if the sole argument of a 1-place verb is Patient-like ((4b), (5b)), the verb cannot take a PV affix.

In terms of argument-marking, in 1-place AV clauses ((4a)-(b), (5a)-(b)), the sole argument invariably bears “Pivot”-marking, regardless of whether it is Agent-like or Theme-like. In 2-place AV clauses ((4c), (5c)), “Pivot”-marking falls on the external argument, with the internal argument carrying a distinct marker, Y. In 2-place PV clauses ((4d), (5d)), “Pivot”-marking falls on the internal argument, with the external argument carrying a third marker, X.¹ This argument-marking pattern is summarized in (6):

(6) TABLE 2.1. Argument-marking alternation in Philippine-type 2-place AV and PV clauses

	a. Actor voice	b. Patient voice
External argument	Pivot	X
Internal argument	Y	Pivot

While the morphological forms of Pivot, X, and Y vary from one language to another, these markers consistently have the function and distribution in (6). Given these consistent observations across languages under different Austronesian primary branches, this argument-marking pattern (6) can be uncontroversially reconstructed to Proto-Austronesian and identified as the prototypical pattern of Philippine-type AV and PV clauses (see also Reid 1979; Ross 2006; Blust 2015):

In this chapter, I revisit a longstanding question in Austronesian syntax that revolves around the nature of the AV/PV distinction as morphologically encoded in (6). Under the conventional analysis, the difference between (6a) and (6b) reflects a transitivity distinction between AV and PV clauses. In this analysis, the PV affix is a transitive marker and the AV affixes an intransitive marker. A controversial assumption embedded in this analysis is that an AV-marked 2-place clause as in (7a)-(b) is syntactically intransitive. Under this assumption, the phrase ‘Ivan’ in (7) is an intransitive subject (S), and the phrase ‘Ryan’ is a non-core object. The morphological marking Y that marks the non-core objects is an oblique case marker.

- (7) h<um>abol si ivan kay ryan. [Tagalog]
 <AV>chase PN.PIVOT Ivan PN.Y Ryan
 ‘Ivan chased Ryan.’

¹ However, an X/Y distinction has been lost in the majority of Philippine-type languages spoken outside Taiwan, including two of the most well-studied languages, Chamorro and Malagasy. Some other languages preserve the distinction only in part of their argument-marking system. For example, in Tagalog, the X/Y distinction is shown in the case markers for personal names (ni vs. kay), but has been partially lost in the markers for common nouns (ng vs. ng/sa).

Building on this assumption, much previous work has maintained that Philippine-type languages exhibit syntactic ergativity, whereby the alleged intransitive subjects (S) in (6a) patterns with the transitive objects (O) in (6b) in both morphological marking (i.e., Pivot) and A'-extraction eligibility (e.g., De Guzman 1976; Payne 1982; Mithun 1994; Aldridge 2004, 2008, 2011, 2016b, 2017).

As this line of analysis relies critically on the purported transitivity distinction between (6a) and (6b), if 2-place AV clauses (6a) are transitive, this transitivity-based approach is invalidated.

In this chapter, I put forward a transitive analysis of Philippine-type 2-place AV clauses. Building on this, I argue against the proposal that Philippine-type languages exhibit syntactic ergativity. Support for my analysis comes from two independent observations of Philippine-type 2-place AV clauses: First, the distribution of the argument marker (Y) on the internal argument of AV-marked verbs shows characteristics typical of structural accusative Case; second, in four languages from different primary branches of Austronesian, AV-marked 2-place verbs are compatible with an understudied detransitivizing operation, reinforcing the transitive analysis for the AV clauses. Building on these observations, I argue for the analysis in (8):

(8) Main claims of the chapter

- a. Philippine-type AV clauses can be either transitive (e.g., (9a)) or intransitive (e.g., (9b)), depending on the semantic skeleton of the verb. An AV-marked verb is capable of licensing structural accusative Case to its internal argument (if it has one).

- (9) a. h<um>abol si ivan kay ryan. [transitive]
 <AV>chase PIVOT Ivan Y=ACC Ryan
 'Ivan chased Ryan.'
- b. k<um>anta si ivan. [intransitive]
 <AV>sing PIVOT Ivan
 'Ivan sang.'

- b. The AV affix is NOT an intransitive marker (reflex of intransitive Voice⁰).
- c. Philippine-type languages do not exhibit ergativity at either the syntactic or morphological level, as both S and A share Pivot-marking with O, and are both accessible to A'-extraction.

This chapter is organized as follows. I begin by outlining the basic traits of Philippine-type Actor voice in 2.2. I then review and critique the intransitive approach to Philippine-type AV clauses in 2.3. In 2.4, I put forward a transitive analysis for Philippine-type 2-place AV clauses. In 2.5, I present three independent pieces of evidence from productive causatives (2.5.1), raising-to-object constructions (2.5.2), and restructuring infinitives (2.5.3), demonstrating that the distribution of Y-marking shows the hallmarks of structural accusative Case. In 2.6, I turn to a heretofore unanalyzed detransitivized construction found in four Philippine-type languages (Puyuma, Thao, Seediq, and Bunun), which lends further support for the transitive analysis of 2-place AV constructions. Section 2.7 summarizes and concludes.

2.2 Philippine-type Actor voice basics

In this section, I summarize the basic characteristics of Philippine-type Actor voice in 2.2.1, then discuss an important asymmetry between Philippine-type AV and PV clauses in 2.2.2.

2.2.1 Philippine-type Actor voice: Overview

Actor voice clauses in Philippine-type languages are characterized by the presence of a reflex of the Proto-Austronesian (PAN) AV affix *<um> on the verb. Common reflexes of PAN AV *<um> include <um>, , <om>, <un>, <en>, <on>, <m>, m-, and zero.²

Many Philippine-type languages also employ a reflex of the Proto-Austronesian stative affix *ma-, which can be viewed as a variant of the AV affix for stative verbs and/or verbs of knowledge/perception.³ For the purpose of this dissertation—which focuses on the argument-marking mechanism of the voice system—I gloss reflexes of both *<um> and *ma- as “AV”.

In Philippine-type languages under the Malayo-Polynesian branch of Austronesian, an AV clause may contain either a reflex of Proto-Austronesian *<um>, or one of two other AV affixes innovative at the Proto-Malayo-Polynesian level: *mag- and *maR-.⁴ In Tagalog, the reflex of the AV affix *maR- and the stative affix *ma- often appear in the form nag- and na-, respectively, as a result of truncation (AV affix + perfective infix <in>: *m<in>aR- > Tagalog nag-; AV affix + perfective stative *m<in>a- > Tagalog na-).

Common AV affixes in Puyuma, Amis, Seediq, and Tagalog are summarized in (10):

(10) TABLE 2.2. AV variants in Puyuma, Amis, Seediq, and Tagalog

a. Puyuma	, <en>, m-, mi-, me-, ma-, Ø
b. Amis	<um>, mi-, ma-, Ø
c. Seediq	<m>, m-, Ø
d. Tagalog	<um>, mag-/nag-, ma-/na-

Below, I outline the basic traits of Philippine-type Actor voice clauses in terms of (i) valency, (ii) argument-marking pattern, (iii) A'-extraction restriction, and (iv) object-marking.

² In some languages, the AV affixes employed are not a regular reflex of *<um> from the perspective of sound correspondence (e.g., mi- (Amis), ma- (Bunun, Amis), mu- (Pazeh)). As such affixes function like a typical AV affixes, they are also glossed as “AV” in the literature.

³ See Chapter 5.4 for my account of the nature of the AV affix, which provides an explanation of why stative verbs share the same AV component (m-) and argument-marking structure with other intransitive verbs.

⁴ For detailed discussion of the allomorphy of the AV affixes, see Blust (1977, 2009), Starosta (2002), Liao (2004, 2011), and Kaufman (2009). Whether or not the lexical stems in Philippine-type language are acategorial is a question under debate. Following the conclusions of this dissertation I refer to them as “verbs” rather than “roots”.

I. Valency

Across Philippine-type languages, AV affixes productively combine with both 1-place verbs and 2-/3-place verbs, with very few lexical constraints.⁵ Importantly, in AV-sentences formed with 2-/3-place verbs, the internal argument(s) are obligatorily present. This is exemplified with the data below from Puyuma and Tagalog, two typical Philippine-type languages:

(11) Puyuma

- a. ka-kawang na bulraybulrayan. [1-place]
 <AV>RED-walk DF.PIVOT young.lady
 ‘The young lady is walking.’
- b. salam na bulraybulrayan *(dra pangudral). [2-place]
 <AV>grow DF.PIVOT young.lady (ID.Y pineapple)
 ‘The young lady grew pineapples.’
- c. em-atelr na bulraybulrayan *(kana maidrang) *(dra tigami). [3-place]
 AV-send DF.PIVOT young.lady (DF.Y old.person) (ID.Y letter)
 ‘The young lady sent the old person a letter.’

(12) Tagalog

- a. ng<um>iti ang babae. [1-place]
 <AV>smile PIVOT woman
 ‘The woman smiled.’
- b. k<um>ain ang babae *(ng kandi). [2-place]
 <AV>buy PIVOT woman (ID.Y candy)
 ‘The woman ate candy.’
- c. nag-bigay ang babae *(ng polvoron) *(kay ivan). [3-place]
 AV.PRF-give PIVOT woman (ID.Y shortbread) (PN.Y Ivan)
 ‘The woman gave Ivan shortbread.’

5 This generalization is supported by comparative evidence below, which shows that both 1-place and 2-place verbs are reconstructable to Proto-Austronesian with an AV form:

a. AV-marked Proto-Austronesian 1-place verbs (source: ACD)

- (1) *q<um>ajaw ‘to shine (sun)’ (2) *q<um>uzaN ‘to rain’ (3) *S<um>eyup ‘to blow’
 (4) *N<um>ajuy ‘to swim’ (5) *C<um>ajis ‘to cry’ (6) *s<um>akay ‘to walk’
 (7) *q<um>etut ‘to fart’ (8) *C<um>ubuq ‘to sprout, to grow’
 (9) *q<um>anjaj ‘to bark (dog)’ (10) *S<um>uni ‘to chirp (bird)’

b. AV-marked Proto-Austronesian 2-place verbs (source: ACD)

- (1) *k<um>aRaC ‘to bite’ (2) *k<um>ali ‘to dig’ (3) *d<um>ilaq ‘to lick’ (4) *k<um>eRet ‘to cut’
 (5) *q<um>aNup ‘to hunt’ (6) *t<um>enun ‘to weave’ (7) *g<um>aruC ‘to comb’
 (8) *k<um>aCu ‘to carry’ (9) *s<um>usu ‘to suckle’ (10) *p<um>anaq ‘to shoot with a bow’

II. Argument-marking pattern

The basic argument-marking pattern of Philippine-type AV clauses is summarized in (13) and illustrated with the data below from Puyuma and Tagalog:

(13) TABLE 2.3. Argument-marking pattern in Philippine-type AV clauses

	Transitives	Unergative	Unaccusative ⁶
External argument	Pivot	Pivot	—
Internal argument	Y	—	Pivot
(Internal argument 2)	(Y)	—	—

(14) Tagalog

- a. t<um>awa si ryan. [unergative verb]
 <AV>laugh PN.PIVOT Ryan
 ‘Ryan laughed.’
- b. b<um>ati si ryan kay ivan. [2-place verb]
 <AV>greet PN.PIVOT Ryan PN.Y Ivan
 ‘Ryan greeted Ivan.’
- c. d<um>ating si ryan. [unaccusative verb]
 <AV>arrive PN.PIVOT Ryan
 ‘Ryan arrived.’

(15) Paiwan

- a. djava-djavac ti kui. [unergative verb]
 <AV>RED-walk SG.PIVOT Kui
 ‘Kui is walking.’ (Chang 2006:426)
- b. talagalj aken tua tja=kanen. [2-place verb]
 <AV>cook 1SG.PIVOT Y 1PL.POSS=food
 ‘I cook what we are going to eat.’ (ODFL)
- c. djaljun a vuaq ti kama kemasi amirika. [unaccusative verb]
 <AV>arrive DEM today SG.PIVOT father from Amerika
 ‘My father will arrive from America today.’ (ODFL)

As seen above, in AV-clauses that contain an unergative verb or 2-place verb, “Pivot”-marking appears on the external argument. In clauses that contain an unaccusative verb, “Pivot”-marking falls on the undergoer. This distribution can be generalized as in (15):

- (16) In Philippine-type AV clauses, Pivot-marking always falls on what is typically defined as the “subject” in nominative-accusative languages.

⁶ See Chapter 3 for discussion of split intransitivity in these languages.

III. A'-extraction restriction

Finally, as is well-known, Philippine-type languages impose a typologically unique constraint in A'-extraction, known as "Pivot-only" (17):

(17) A'-extraction restriction in Philippine-type languages

Only the Pivot-marked phrase in a clause may undergo A'-extraction (i.e., relativization and pseudo-clefting).

Under (17), in AV-clauses that involve an intransitive verb, the Pivot-marked sole argument can always undergo A'-extraction, regardless of its thematic role. This is exemplified in (18)-(19):

(18) A'-extraction in 1-place AV clauses: Seediq

- a. k<m><n>eeki /m-<n>huqil/m-bserux ka robo.
 <AV><PRF>**dance**/ AV-<PRF>**die**/AV-**lazy** PIVOT Robo
 'Robo danced/died/is lazy.'
- b. ima ka [k<m><n>eeki /m-<n>huqil /m-bserux]?
 who PIVOT [<AV><PRF>**dance**/ AV<PRF>**die**/ AV-**lazy**]
 'Who danced?'/ 'Who passed away?'/ 'Who is lazy?'

(19) A'-extraction in 1-place AV clauses: Puyuma

- a. senay/m<in>atray/ma-tuka i senten.
 <AV>**sing**/AV<PRF>**die**/AV-**lazy** SG.PIVOT Senten
 'Senten sang/died/is lazy.'
- b. imanay na [senay/m<in>atray/ma-tuka]?
 who PIVOT [<AV>**sing**/AV<PRF>**die**/AV-**lazy**]
 'Who sang?'/ 'Who passed away?'/ 'Who is lazy?'

In AV-clauses that contain a 2-place verb, only the external argument, i.e., the Pivot, can undergo A'-extraction. This is seen in (20b)-(c) and (21b)-(c):

(20) A'-extraction restriction in 2-place AV clauses: Seediq

- a. q<m><n>iyuc Ø ngiyo ka huling nii.
 bite<AV><PRF> Y cat PIVOT dog this
 'This dog bit the cat.'
- b. maanu ka [q<m><n>iyuc Ø ngiyo]?
 what PIVOT [<AV><PRF>bite Y cat]
 'What bit the cat?'
- c. *maanu ka [q<m><n>iyuc ka huling]?
 what PIVOT [<AV><PRF>bite PIVOT dog]
 (Intended: 'What did the dog bite?')

(21) A'-extraction restriction in 2-place AV clauses: Puyuma

- a. trakaw i sawagu kantu=paliding.
 <AV>steal SG.PIVOT Sawagu 3.POSS.X=car
 'Sawagu stole his/her car.'
- b. imanay na [trakaw kantu=paliding]?
 who PIVOT [<AV>steal 3.POSS.Y=car]
 'who stole his/her car?'
- c. *amanay ka [trakaw i sawagu]?
 what PIVOT [<AV>steal SG.PIVOT Sawagu]
 (Intended: 'What did Sawagu steal?')

IV. Object marking

In some Philippine-type languages, the objects of AV-marked verbs tend to bear indefinite or non-specific argument-marking. This observation has been used as an argument for the intransitive analysis of 2-place AV clauses (see Section 2.3.3 for details). This characteristic, however, cannot be viewed as a prototypical trait of Philippine-type Actor voice for several reasons. To the best of my knowledge, the languages known to show this constraint all belong to a single Austronesian primary branch, Malayo-Polynesian, whereas the Philippine-type voice system is found across nine of the ten Austronesian primary branches. This suggests that the indefinite/non-specific interpretation of AV objects may be an innovation below the Proto-Malayo-Polynesian-level. Moreover, this constraint is not found in all Malayo-Polynesian languages. For instance, while two Central Philippine languages, Tagalog and Kapampangan, exhibit this constraint (Aldridge 2004, Bäscher p.c.), two other Malayo-Polynesian languages, Malagasy and Subanon, do not (Paul & Travis 2006; O'Brien 2016). This suggests that the tendency of AV objects to be indefinite/nonspecific is a later development at a lower level(s) within Malayo-Polynesian.

2.2.2 The AV/PV asymmetry

As previewed in Section 2.1, an important asymmetry between Philippine-type AV and PV clauses lies in their compatibility with 1-place verbs: while the AV affixes are free to combine with both 1-place and 2-place verbs (22a)-(b) and (23a)-(b), the PV affixes cannot combine with 1-place verbs. This restriction has nothing to do with the thematic role of the sole argument selected by the verb. As seen in (22c) and (23c), even if the 1-place verb selects a Patient/Theme-like argument, it cannot be PV-marked.

(22) Amis

- a. mi-dangoy ku wacu. [✓ Actor voice, 1-place]
 AV-swim PIVOT dog
 'The dog swam.'

- b. mi-kalat ku wacu tu pusi. [✓ Actor voice, 2-place]
AV-bite PIVOT dog Y cat
 ‘The dog bit the cat.’
- c. *patay-en ku wacu. [× Patient voice, 1-place]
die-PV PIVOT dog
 (‘The dog will die.’)
- d. kalat-en nu wacu ku pusi. [✓ Patient voice, 2-place]
bite-PV X dog PIVOT cat
 ‘The dog will bite the cat.’⁷

(23) Tagalog

- a. l<um>angoy si ivan. [✓ Actor voice, 1-place]
 <AV>**swim** PN.PIVOT Ivan
 ‘Ivan swam.’
- b. p<um>atay si ivan ng aso. [✓ Actor voice, 2-place]
 <AV>**kill** PN.PIVOT Ivan ID.Y dog
 ‘Ivan killed a dog.’
- c. *ma-matay-in si juan. [× Patient voice, 1-place]
 CONT-**die-PV** PN.PIVOT Juan
 (‘Juan will die.’)
- d. pa-patay-in ni ivan ang aso. [✓ Patient voice, 2-place]
 CONT-**kill-PV** X Ivan PIVOT dog
 ‘Ivan will kill the dog.’

Two observations can be made about the data above. First, the distribution of the PV affix is strictly tied to 2-place verbs, whereas that of the AV affixes is not. Second, there is an obvious mismatch between the conventional labels “Actor” voice and “Patient” voice and the actual distributions of these two affixes.⁸ The “AV” and “PV” affixes do not select a Pivot phrase based on its thematic role.

With these background observations in mind, I revisit the intransitive analysis of Philippine-type AV clauses in 2.3.

2.3 Issues in the intransitive approach to Philippine-type Actor voice clauses

In this section, I summarize and critique the intransitive approach to Philippine-type 2-place Actor voice. I first provide a summary of previous intransitive analyses (2.3.1), and discuss how this

⁷ In Amis, the PV affix -en commonly denotes future interpretation.

⁸ See also Rackowski (2002) for a similar claim.

approach has been articulated under the framework of generative syntax (2.3.2). Finally, I outline problems with this approach (2.3.3).

2.3.1 Basic assumptions of the intransitive analysis of Actor voice

As introduced in 2.1, much previous work has attributed the argument-marking alternation between Philippine-type AV and PV clauses to an alleged transitivity distinction between the two clause types (e.g., De Guzman 1988; Gerdts 1988; Payne 1982; Mithun 1994; Aldridge 2004 et seq.; Ross 2002; Liao 2004; Chang 2011). Under this line of analysis, PV clauses are the basic transitives, and 2-place AV clauses are antipassive constructions that contain a non-core oblique object.

This analysis serves as the basis of an ergative approach to Philippine-type languages, according to which the argument marker “Pivot,” which falls on the internal argument in PV clauses and the external argument in AV clauses, realizes absolutive Case. The argument markers X and Y are claimed to realize ergative and oblique case, respectively. This is illustrated in the table in (24) and the Puyuma data in (25).

(24) TABLE 2.4. The ergative approach to AV/PV asymmetry

	a. Actor voice	b. Patient voice
External argument	Pivot = absolutive	X = ergative
Internal argument	(Y = oblique)	Pivot = absolutive

(25) Puyuma

- a. deru=ku dra bunga. [Actor voice (“intransitive”)]
 <INTR>cook=1SG.ABS ID.OBL **yam**
 ‘I cooked yam.’
- b. ku=deru-aw na bunga. [Patient voice (“transitive”)]
 1SG.ERG=cook-TR DF.ABS **yam**
 ‘I cooked yam.’

Under this analysis, the Philippine-type “Pivot-only” constraint in A’-extraction (17) has been considered a manifestation of syntactic ergativity: As the A’-extractable phrases in these languages are restricted to the purported absolutives (e.g., De Guzman 1988; Gerdts 1988; Payne 1982; Mithun 1994; Aldridge 2004 et seq.; Liao 2004; Chang 2011, 2013, 2015), Philippine-type Austronesian languages have been claimed to be typologically similar to Dyirbal, Yup’ik, Greenlandic, Chukchi, and the majority of Mayan languages (Payne 1982; Aldridge 2004, 2008; 2011).

In what follows, I summarize this approach under the framework of the Minimalist Program.

2.3.2 Previous formal approaches to the intransitive analysis of Actor voice

Since Aldridge (2004), the ergative approach to Philippine-type voice systems has been adopted in a number of subsequent works (e.g., Aldridge 2008, 2011, 2014, 2015, 2016a, b, 2017; Chang 2009, 2011, 2013; Wu 2013; Legate 2014; Kuo 2015). In this subsection, I summarize the core assumptions of this proposal:

I. Transitivity distinction between AV and non-AV clauses

Under the ergative approach to Philippine-type languages, both the AV and PV affixes are transitivity marking. The former is the morphological reflex of intransitive v^0 (equivalent to Voice^0 under the framework used in this dissertation) (26a) and the latter transitive v (henceforth Voice^0) (26b). Under Aldridge's analysis, intransitive Voice^0 is incapable of licensing inherent ergative Case to its specifier, and lacks an EPP feature, as opposed to transitive Voice^0 (26b), which is capable of assigning ergative Case to its external argument, and employs an EPP feature that attracts the highest internal argument to the outer specifier of VoiceP .⁹

According to this analysis, the external argument of a PV clause is inherently Case-licensed with ergative Case, while that in an AV clause is not. Furthermore, it is only in PV clauses that the internal argument undergoes Object Shift (e.g., Holmberg 1986; Neeleman 1994; Bobaljik 1995) and raises to the outer specifier of Voice^0 due to the presence of an EPP feature on Voice^0 . In AV clauses, the internal argument is assumed to stay in its base-generated position, i.e., the complement of VP, and receives lexical oblique case from the lexical verb (V^0). This is illustrated with the tree diagrams in (26a)-(b):

⁹ The notion of the Extended Projection Principle (EPP) is primarily motivated by the observation that most, if not all, human languages employ a subject position that must be filled by a NP/DP (Chomsky 1981, 1982, 1995). This assumption is later applied to other functional heads such as C and Voice. The basic idea of EPP is that it will trigger a phrase that is base-generated below a functional head to move to the specifier position of the head. For instance, external arguments base-generated at [Spec VoiceP] will raise to the subject position, [Spec TP], due to EPP on T.

(26) a. AV clauses

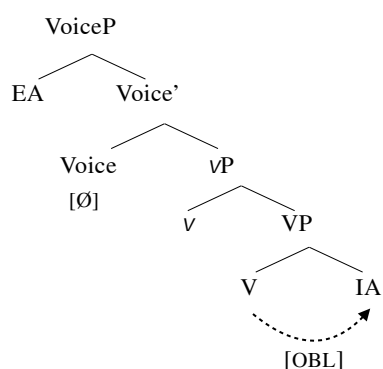

- absence of an EPP on Voice⁰
- presence of intransitive Voice⁰
- no inherent ergative Case

b. PV clauses

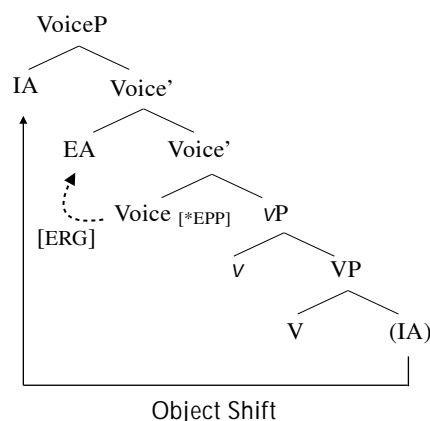

- presence of an EPP on Voice⁰
- presence of transitive Voice⁰
- inherent ergative Case assigned upward to EA

II. Pivot marks structural absolutive (/nominative) Case¹⁰

Another important assumption under this approach is that “Pivot”-marking realizes absolutive/nominative Case, which probes the highest Caseless argument in a clause. Under this proposal, Pivot-marking is assigned to the internal argument in PV clauses, as the external argument in PV clauses is inherently Case-licensed with ergative Case. Under the standard assumption that nonstructural Cases are licensed prior to structural Case (Marantz 1993; Woolford 2006; Bobaljik 2008), ergative Case is licensed prior to absolutive Case. This proposed Case-licensing mechanism is illustrated in (27) below.

(27) a. Case-licensing in AV clauses

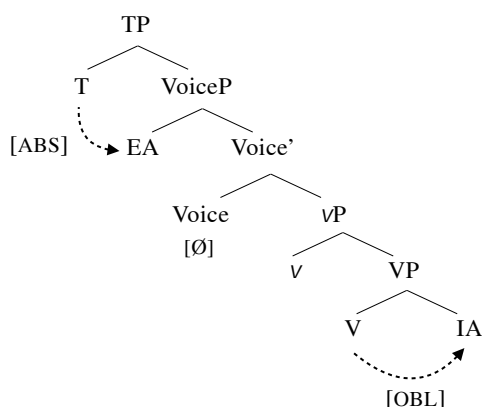

b. Case-licensing in PV clauses

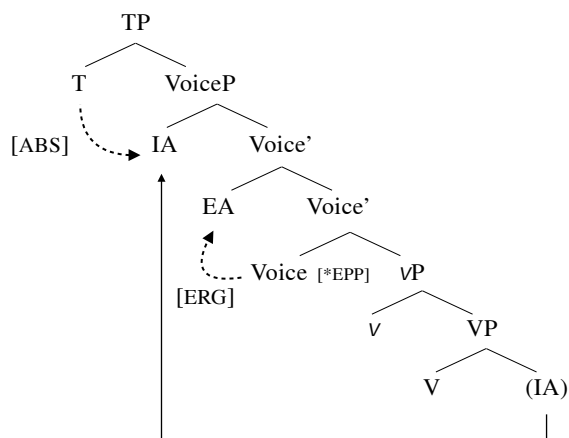

¹⁰ Aldridge (2004) proposes that Philippine-type languages manifest two subtypes of ergativity, T-type (i.e., high-absolutive) and v-type (i.e., low-absolutive). As this distinction has been eliminated in her later works (2015, 2016a, b), which assume the source of Pivot-marking to be unitarily from finite C/T, I will stick to her latest analysis.

I do not discuss the proposed Case-licensing mechanism in Locative voice (LV) and Circumstantial voice (CV) in this chapter. See a relevant discussion in Chapter 4.

III. The “Pivot-only” constraint as a hallmark of syntactic ergativity

A third important assumption under Aldridge’s approach is that the Philippine-type “Pivot-only” constraint in A’-extraction is essentially an “Absolute-only” constraint parallel to that observed in syntactically ergative languages. Under her analysis, the “Pivot”-only constraint is an outcome of Philippine-type languages’ employing the Attract Closest constraint (Bittner & Hale 1996) in A’-extraction:

(28) The Attract Closest constraint

Only the structurally highest argument in a clause may undergo A’-extraction.

Under (28), whether or not an external argument in Philippine-type languages can be A’-extracted is tied to the alleged presence or absence of an EPP feature on Voice⁰. Whenever an EPP feature is assumed to be present (e.g., in PV clauses), it is the internal argument and not the external argument that is accessible to A’-extraction—as the internal argument is assumed to be the structurally highest argument in the clause. Whenever an EPP feature is proposed to be absent (i.e., in AV clauses), it is the external argument that is eligible to A’-extraction, as the internal argument is assumed to stay within the VP domain.

To sum up, the validity of the ergative approach to Philippine-type languages relies crucially on a transitivity distinction between AV and non-AV clauses. This assumption enables the alleged asymmetry in the presence or absence of (i) an EPP feature and (ii) ergative Case between AV and PV clauses. Whether or not 2-place AV clauses are indeed syntactically intransitive thus plays a crucial role in evaluating the validity of this analysis.

2.3.3 Issues in the antipassive analysis of Philippine-type AV clauses

In what follows, I outline problems with the intransitive approach to Philippine-type AV clauses.

As outlined in Section 2.1, Philippine-type 2-place AV clauses are conventionally viewed as antipassive constructions that contain an intransitive subject and a non-core object. The term *antipassive* refers to a cline of detransitivized constructions characterized by having the logical direct object of a transitive verb either appear as a non-core phrase or else left unexpressed. Under the standard analysis, canonical antipassive constructions are defined by the following traits (Baker 1988; Campbell 2000; Cooreman 1994; Dixon 1979, 1994; Dryer 1990; England 1988; Anderson 1976; Polinsky 2016; Heaton 2017):

- (29) Typical traits of antipassive constructions
- Explicit morphology on the semantically transitive verb that indicates antipassivization.
 - The underlying transitive object is marked by a non-core case or adposition.
 - The object can be optionally omitted.
 - The object is often indefinite/non-specific and bears narrow scope.
 - The object often bears partitive reading and is interpreted as less affected.
 - The denoted event tends to be interpreted as less completed (imperfective).

The traits in (29a)-(c) are illustrated below with data below from Chukchi (Chukotko-Kamchatkan) and Dyirbal (Pama–Nyungan). As seen in (30)-(31), in both languages, an antipassive construction is morphologically distinct from an intransitive clause. The former carries an antipassive marker on the verb ((30b), (31b)), whereas the latter does not ((30c), (31c)):

(30) Chukchi (Chukotko-Kamchatkan)

- | | | |
|----|--|----------------|
| a. | tumg-e ŋinqey rəyegtetew-nin.
friend-ERG boy.ABS save-AOR.3SG:3SG
'The friend saved the boy.' | [transitive] |
| b. | tumgətum (ŋinqey-ək) ine -nyegtele-gʔi.
friend.ABS (boy-LOC) AP-save-AOR.3SG
'The friend saved the boy.' | [antipassive] |
| c. | ŋinqey pəkir-gʔi.
boy.ABS arrive-AOR.3SG
'The boy arrived.' (Polinsky to appear:14) | [intransitive] |

(31) Dyirbal (Pama–Nyungan)

- | | | |
|----|---|----------------|
| a. | yabu ŋuma-ŋgu bura-n.
mother.ABS father-ERG see-NONFUT
'Father saw mother.' | [transitive] |
| b. | ŋuma bural-!a-n ^y u (yabu-gu).
father.ABS see-AP-NONFUT (mother-DAT)
'Father saw mother.' | [antipassive] |
| c. | ŋuma banaga-n ^y u.
father.ABS return-NONFUT
'Father returned.' (Dixon 1994:10,13) | [intransitive] |

Moreover, the demoted object in the antipassive constructions above can be omitted without semantic consequences, as seen in (30b) and (31b).

Canonical antipassives differ from Philippine-type 2-place AV-clauses in two substantial ways. First, antipassive objects are typically omissible, whereas omission of the object of Philippine-

type 2-place AV results in ungrammaticality. See the following data from three typical Philippine-type languages, Tagalog, Puyuma, and Amis:¹¹

(32) Ungrammaticality of object omission in AV clauses

- a. b<um>ili ang babae *(ng kendi). [Tagalog]
 <AV>buy PIVOT woman *(ID.Y candy)
 ‘The woman bought candy.’
- b. trima na babayan *(dra patraka). [Puyuma]
 <AV>buy PIVOT woman *(ID.Y meat)
 ‘The woman bought meat.’
- c. mi-‘aca k-una fafahi *(to nanges). [Amis]
 AV-buy PIVOT-that woman *(Y fruit)
 ‘That woman bought fruit.’

Second, unlike canonical antipassives, Philippine-type 2-place AV clauses do not employ an explicit antipassive marker. As seen in the Tagalog data below, the alleged antipassives in (33b) share the same verbal morphology, i.e., the AV affix, with the intransitive verbs in (33a).

(33) Tagalog

- a. s<um>ayaw ang babae. [AV-clause with an intransitive verb]
 <AV=INTR>dance PIVOT woman
 ‘The woman danced.’
- b. s<um>ulat-Ø ang babae ng liham. [2-place AV clause (“antipassive”)]
 <AV=INTR>write-AP PIVOT woman ID.Y letter
 ‘The woman wrote a letter.’
- c. s<in>ulat ng babae ang liham. [2-place AV clauses]
 <PV.PRF=TR> X woman PIVOT letter
 ‘The woman wrote the letter.’

Therefore, under Aldridge’s analysis that an AV affix is an intransitive marker (i.e., reflex of intransitive Voice⁰), the argument-marking patterns in (33a)-(b) will force a typologically rare generalization in (34):

(34) Antipassivization in Philippine-type languages is not morphologically marked, while basic transitive clauses in these languages carry an overt transitive marker (i.e., the PV affix).

¹¹ Aldridge (2012:196) reports that Philippine-type AV clauses allow the object to be optionally omitted, drawing on an example from the verb k<um>ain ‘eat’ in Tagalog. According to three Tagalog speakers I consulted, such flexibility is bound to this specific verb’s valency ambiguity and does not apply to canonical 2-place verbs.

The assumption that antipassivization is not morphologically marked in Philippine-type voice systems raises serious issues for Aldridge’s analysis of the voice-marking mechanism in these languages. As the purported antipassiving operation must be analyzed as phonologically null, it implies that *Philippine-type languages employ an overt marker for transitive clauses while not for antipassives*—a marking strategy that is otherwise unattested.

Alternatively, if one argues that the purported antipassive (e.g., (33b)) is the default structure selected by the semantically transitive verb ‘buy’, it entails the analysis of the PV affix in the transitive clause (33c) as an applicative marker, which increases the valency of the clause from intransitive to transitive. The theoretical shortcomings in either approach call for a reconsideration of the validity of the antipassive analysis of 2-place AV clauses.

In addition to these two major theoretical issues, Philippine-type 2-place AV clauses also differ from canonical antipassives in their compatibility with definite/specific objects. As already pointed out by different authors, many Philippine-type languages are free to employ definite/specific objects (e.g., (35a)-(c)), with only a few languages (e.g., Tagalog, Kapampangan) reported to prefer indefinite/nonspecific objects in AV clauses. Typical antipassive constructions, on the other hand, are known to employ indefinite objects (see (29d)). In this aspect as well, Philippine-type AV constructions differ from canonical antipassives.

(35) Compatibility of definite/specific objects in Philippine-type AV clauses

- a. nanapahan’i sahondra **ity** hazo ity nu antsy. [Malagasy]
 PAST.AV.cut Sahondra **this** tree this DET knife
 ‘Sahondra cut this tree with the knife.’ (Paul & Travis 2006:316)
- b. k<um>an si juan nog saging **koyon**. [Subanon]
 <AV.IRR>eat PIVOT Juan Y banana DET
 ‘Juan will eat that banana.’ (O’Brien 2016:11)
- c. mi-takaw cira **tu payso nu ina nira**. [Amis]
 AV-steal 3SG.PIVOT Y money POSS mother 3SG.POSS
 ‘He stole his mother’s money.’ (ODFL)

Finally, across Philippine-type languages, an AV-marked verb may select a finite clausal complement, as in (36a)-(c). Under the antipassive analysis of 2-place verbs, the finite clausal complements in (36) are necessarily analyzed as an antipassive object. The theoretical soundness of this treatment is questionable, raising further doubts for the antipassive analysis.

(36) Complex sentences marked with a matrix AV verb

- a. me-na’u=ku [dra nu=trakaw-aw ku=paysu adaman]. [Puyuma]
 AV-see=1SG.PIVOT [C 2SG.X=steal-PV 1SG.PIVOT.POSS=money yesterday]
 ‘I saw that you stole my money yesterday.’
- b. nanaginip si ivan [na nag-alaga ng lobo si viktorija]. [Tagalog]
 AV.PRF.dream PN.PIVOT Ivan [C AV.PRF-raise ID.Y wolf PN.PIVOT Victoria]

'Ivan dreamt that Victoria raised a wolf.'

- c. mihevitra rabe [fa didian' ny vehivavy amin'-ny antsy ny mofo]. [Malagasy]
AV.think Rabe [C PV.cut DET woman with-DET knife DET bread]¹²
'Rabe thinks that the woman is cutting the bread with the knife.' (Pearson 2005:432)

Below, I revisit previous arguments for the antipassive analysis of 2-place AV clauses, and discuss why these arguments are not valid.

I. A'-extraction restriction on AV objects

That AV objects cannot be A'-extracted has been used as an argument for the oblique analysis (Aldridge 2004, 2011). However, an A'-extraction restriction applies not only to AV objects, but to all non-Pivot marked phrases in Philippine-type languages. Therefore, I consider these arguments indecisive for the antipassive analysis.

II. Indefinite/nonspecific interpretation of AV objects

A second argument for the antipassive analysis is the claim that AV objects tend to be indefinite/non-specific (Aldridge 2004, 2008, 2011, Liao 2004). However, the presence or absence of this constraint and the strength of the preference varies from one Philippine-type language to another. Below I summarize the observations from several Philippine-type languages.

(a) Tagalog and Kapampangan: Indefinite/non-specific AV objects

AV objects in Tagalog are generally agreed to be overwhelmingly indefinite and non-specific (Aldridge 2004, Kaufman 2009, pc.); a Tagalog native speaker I consulted also reported that definite/specific nominals including 1) personal pronouns, 2) personal names, and 3) nominals marked with demonstrative are less preferred to be used as AV objects. However, two recent studies have shown that the definite/specific restriction on AV objects might be conditioned by multiple factors. Tanaka (2016) report that in spontaneously produced sentences by 44 Tagalog-speaking adults describing events with a definite agent and a definite inanimate patient, the percentage of AV vs. PV production is 52.78% : 47.22%. This suggests that definiteness constraint of AV objects may not be highly restricted in natural speech, and the reported indefiniteness tendency may be subject to factors such as animacy. Collins (2016) has also shown that depending on the pragmatics, an AV clause may be preferred with definite objects in some situations.

In Kapampangan, a Central Luzon language, AV objects are also reported to show a general tendency to be indefinite/non-specific, manifested by the fact that proper names and personal pronouns are preferably placed as PV objects (Kevin Bäscher p.c.).

¹² For the sake of consistency, the original glosses AT "Actor trigger" and TT "Theme trigger" in Pearson (2005) are changed to AV and PV, respectively.

- (b) Subanon, Malagasy, and Formosan languages: The absence of an indefinite/non-specific constraint on AV objects

Unlike Tagalog and Kapampangan, two other Malayo-Polynesian languages Subanon and Malagasy are reported to show no indefinite/non-specific tendency on AV objects (O'Brien 2016; Paul & Travis 2006), as illustrated previously in (20a)-(b). In the eight Formosan languages I surveyed (Puyuma, Amis, Kavalan, Atayal, Seediq, Paiwan, Pazeh, and Bunun), an indefinite/specific restriction on AV objects is absent as well, as exemplified with the following data (37)-(38):

(37) Definite/specific objects in AV clauses

- a. keLem ti palang tjay kalalu. [Paiwan]
 <AV>hit SG.PIVOT Palang SG.Y Kalalu
 'Palang hit Kalalu.' (Chang 2006:71)
- b. ima ka k<m><n>eruc qulic [p<n>hma-an=mu] nii? [Seediq]
 who PIVOT <AV><PRF>cut cedar [grow<PRF>-LV=1SG.X] this
 'Who cut this cedar I grew?' (ODFL)

(38) Puyuma

- a. Ø-sagar=ku √dra/√kana/√kan-drini aputr. [AV]
 AV-like=1SG.PIVOT ID.Y/ DF.Y/ Y-this flower
 'I like flowers (generic)/the flower (definite)/this flower.'
- b. saletra' na sinsi kanku/kan senten. [AV]
 <AV>slap DF.PIVOT teacher 1SG.Y/SG.Y Senten
 'The teacher slapped me/Senten.'

As the majority of highest-order Philippine-type languages do not show a restriction or dispreference to employ definite/specific AV objects, I consider this constraint a secondary innovation in some Philippine-type languages.

III. Difference in scopal interpretation between 2-place AV clauses and PV clauses

Aldridge (2004, 2011) has reported that PV objects in Tagalog may take scope over the external argument (39a), while AV objects cannot (39b), supporting an antipassive analysis:

(39) Tagalog

- a. Pivot 'all' > Y 'many': interpreted as one set of books
 nag-basa ang [lahat-ng bata] ng [marami-ng libro]. [AV]
 AV.PRF-read PIVOT [all-LK child] ID.Y [many-LK book]
 'All children read many books.'

- b. Pivot ‘many’ > X ‘all’: interpreted as different sets of books

b<in>basa ng [lahat-ng bata] ang [marami-ng libro]. [PV]
 <PV.PRF>read X [all-LK child] PIVOT [many-LK book]
 ‘All children read many books.’ (Aldridge 2004:119, 2011:195)

However, two Tagalog speakers I consulted rejected the reported scope difference and judged both as allowing either interpretation. Due to the limited amount of data provided in Aldridge (2004, 2011), it is difficult to further evaluate the potential inter-speaker variations on scopal interpretation.

Across Malagasy, Puyuma, Amis, and Seediq, AV objects are reported to be able take wide scope over the external argument, exemplified in (40)-(41):

- (40) Malagasy

namaky [ny boky roa] [ny mpianatra tsirairay].
 PST.AV.read [DET book two] [DET student each]
 ‘Each student read two books.’ [“Obl” ‘two’ > Pivot ‘each’] (Paul & Travis 2006:323)

- (41) Puyuma

senay [na lalak driya] [kana saya a senay].
 AV-sing [DF.PIVOT children every] [DF.Y one LK song]
 ‘Every child sang one song.’ [“Obl” ‘one’ > Pivot ‘every’]

I conclude that the properties of AV objects may exhibit a certain degree of crosslinguistic variation among Philippine-type language. Furthermore, inter-speaker variation is difficult to exclude in scopal diagnostics. Thus, scope interpretation may not be a sound argument for the antipassive analysis for 2-place Philippine-type AV clauses.

IV. Telicity and affectedness as an argument for the antipassive analysis

Several previous works have argued for an antipassive analysis for AV clauses based on the observation that AV objects are interpreted as less affected or less telic than PV objects (e.g., Huang 1994; Liao 2004; Nolasco 2009).

However, with more data available the default aspectual reading of each voice type has been shown to vary from one language to another. The table below summarizes the reported default aspectual interpretation of AV, PV, and LV in six Philippine-type languages:

(42) TABLE 2.5. Default aspectual interpretation in six Philippine-type languages

	AV	PV	LV	Sources
a. Atayal/Seediq	imperfective	future	perfective	Huang (2005); primary data
b. Puyuma (Nanwang)	perfective	perfective	perfective	primary data; Teng (2008)
c. Paiwan (Northern)	perfective	perfective	perfective	Chang (2006); ODFL
d. Amis (Central)	(varies)	future	perfective	primary data; ODFL
e. Tagalog	(must be inflected with an aspect marker)			primary data; Schachter & Otnes (1972)
f. Malagasy	future	perfective	perfective	Pearson (2016)

As seen in (114), there appears to be no obvious consensus on the default aspectual interpretation of AV clauses among Philippine-type languages, not to mention idiosyncratic differences among different verbs. Given the observed variation, I conclude that affectedness and telicity interpretation may not constitute sound evidence for the transitivity of AV clauses.

2.4 The competing hypothesis

Contra the conventional analysis, I argue that Philippine-type 2-place AV clauses are true transitives, rather than antipassives. Under this proposal, AV-marked verbs in Philippine-type languages are capable of licensing structural accusative Case to their internal argument. They can either be intransitive or transitive, depending on the semantic skeleton of the verb. This proposal is illustrated with Tagalog data (42a)-(b):

(43) Tagalog

- a. t<um>alon ang babae. [intransitive]
 <AV>jump PIVOT woman
 'The woman jumped.'
- b. t<um>ili ang babae ng kendi. [transitive]
 <AV>buy PIVOT woman Y=ACC candy
 'The woman bought candy.'

Support for this analysis comes from two independent observations: First, the distribution of the argument marker Y shows characteristics typical of structural accusative Case. Second, across four Philippine-type languages, the alleged antipassive constructions are compatible with a detransitivizing operation.

In Section 2.5, I will discuss three constructions that provide novel evidence for the accusative Case analysis of Y-marking. Before entering into the discussion, I outline the assumptions I adopt regarding Case.

Under the standard analysis of Case in the Minimalist Program, accusative Case and oblique Case differ in their distribution (Bobaljik 1998; Woolford 2006). Lexical oblique Case is strictly licensed in Head-complement relation along with θ -assignment, as in (44):

(44) Oblique Case: Head-Comp-licensing

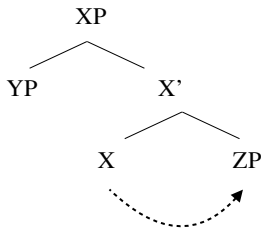

Structural accusative Case, on the other hand, can be licensed either in Head-complement relation (45a) or across a clausal boundary to an embedded external argument. The latter phenomenon is known as the ECM configuration, illustrated in (45b).

(45) a. Accusative Case: Head-Comp-licensing b. Accusative Case: ECM-licensing

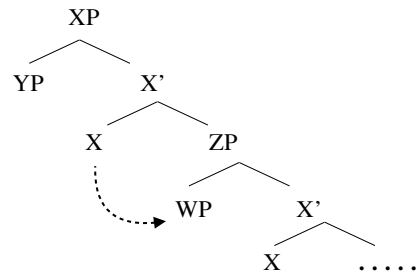
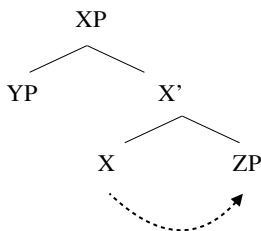

Given the different distributional properties of oblique Case and accusative Case, we can clarify the nature of Y-marking based on its distribution in specific environments: If Y realizes lexical oblique Case, it should be restricted to the internal argument position. If it realizes accusative Case, it is predicted to be available to both the internal argument position (45a) and embedded external argument position (45b).

In the following section, I will show that the distribution of Y shows the hallmarks of structural accusative Case in productive causatives (2.5.1), raising-to-object (2.5.2), and restructuring constructions (2.5.3).

2.5 The accusative Case behaviors of Y-marking

2.5.1 Productive causatives: The ECM-behavior of Y-marking

The first argument for the transitive analysis of 2-place AV clauses comes from the ECM-behavior of Y-marking in productive causative constructions.

As introduced in 2.4, Exceptional Case marking (ECM) (Chomsky 1981, 1986) is standardly considered a typical characteristic of structural accusative Case, whereby the external argument of a nonfinite embedded clause is Case-licensed by the higher Voice⁰. This results in the phenomenon of the subject of a nonfinite embedded clause sharing the same case-marking (accusative) with normal direct objects in transitive clauses, as illustrated in (46a)-(b):

(46) Exceptional Case-marking configuration

a. ECM Case-licensing

b. Accusative Case-licensing in simple transitives

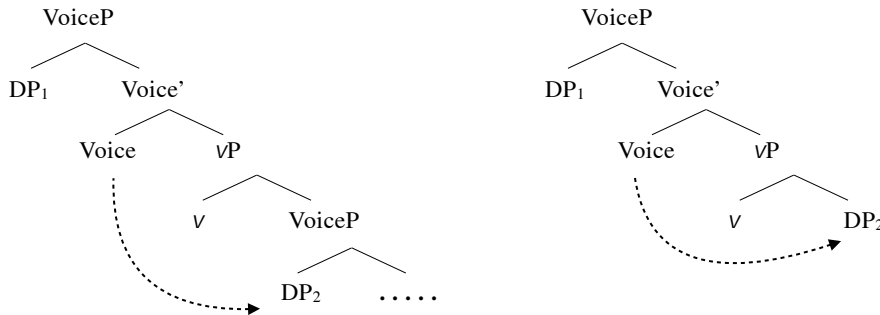

Importantly, this Case-licensing configurations (46a) does not apply to lexical oblique Case. As the source of oblique Case is V, oblique Case cannot be assigned an embedded external argument— as there is no lexical Case licenser in the matrix verbal phrase in configuration like (46a). Therefore, if Y-marking in Philippine-type languages shows ECM-phenomena, this will lend direct support to an accusative Case analysis of Y.

ECM-configurations are commonly observed in productive causative constructions across languages. As seen in (47)-(48), in English and Spanish causatives, the Causee shares accusative case with the direct object in simple clauses, as if it is a direct object of the causing event:

(47) English

- a. John asked [**her** to eat chocolate].
- b. John kissed **her**.

(48) Spanish

- a. Juan **la** hizo [rechazar el premio].
 Juan **3SF.ACC** made [reject-INF the prize]

‘Juan made her reject the prize.’ (Sheehan & Cyrino 2016:280)

- b. Juan **la** ama.
 Juan **3SF.ACC** love
 ‘Juan loves her.’

A similar phenomenon is attested in productive causatives across Philippine-type Austronesian languages. According to primary fieldwork and secondary data, the argument marker Y shows ECM-behavior across at least 16 Philippine-type languages: Amis, Atayal, Ida’an Begak, Bikol, Bunun, Cebuano, Ilocano, Kavalan, Muna, Paiwan, Puyuma, Saisiyat, Seediq, Tagalog, Thao, and Tsou.¹³ Together, these languages represent nine of the ten Austronesian primary branches, and each shares the same argument-marking pattern in productive causatives.

In most Philippine-type languages, productive causativization is marked by a reflex of the Proto-Austronesian causative prefix *pa- on the verb. Across these languages, when a productive causative is AV-marked (henceforth AV-causatives), Pivot-marking falls on the Causer, with the Causee obligatorily Y-marked (49a). Therefore, the Causee in AV-causatives shares Y-marking with the object of simple AV-clauses (49b):

(49) Tagalog

- a. **nag-pa**-habol ako **ng** **aso** sa pusa.
 AV.PRF-CAU-chase 1SG.PIVOT ID.Y **dog** DF.Y cat
 ‘I made a/the dog chase the cat.’
- b. h<um>abol ang pusa **ng** **aso**.
 <AV>chase PIVOT cat ID.Y **dog**
 ‘The cat chased a/the dog.’

While the exact morphological form of Y varies from one language to another, Y-marking is obligatorily present on the Causee in AV-causatives across Philippine-type languages. As there has been no other type of argument-marking pattern observed in AV-causatives, this shared case pattern can be considered as reflecting the prototypical distribution of Y-marking (50):

(50) TABLE 2.6. Shared argument-marking between Causee and AV objects

	a. simple AV clause	b. AV-causative	
External argument	Pivot	Pivot	Causer (external argument)
Internal argument	Y	Y	Causee (external argument)
		Y	Causand (internal argument)

¹³ Sources: Atayal (Huang 2005), Puyuma (Kuo 2015, V. Chen 2017), Amis (Kuo 2015; V. Chen 2017), Kavalan (Don-yi Lin p.c.), Seediq (Holmer 1999), Tsou (G. Lin 2010, Chang 2015), Paiwan (Chang 2006), Bunun (Zeitoun 2000a), Saisiyat (Yeh 2000, Zeitoun et al. 2015), Tagalog (Maclachlan 1996, Travis 2001, Rackowski 2002), Ilocano (Silva-Corvalán 1978), Cebuano (Tanangkingsing 2009), Bikol (Mintz 1971).

This argument-marking pattern is illustrated with data below from Puyuma, Amis, and Seediq (51)-(53):¹⁴

(51) Puyuma

- a. p<en>ukepuk na sinsi **kan senten.** [simple AV-clause]
 <AV>hit DF.PIVOT teacher **SG.Y Senten**
 ‘The teacher hit Senten.’
- b. Ø-**pa**-sabsab=ku **kan senten** kana paliding. [AV-causative]
 AV-CAU-wash=1SG.PIVOT **SG.Y Senten** DF.Y car
 ‘I asked Senten to wash the car.’

(52) Amis

- a. mi-palu kaku **ci-sawmah-an.** [simple AV clause]
 AV-hit 1SG.PIVOT **PN-Sawmah-Y**
 ‘I hit Sawmah.’
- b. Ø-**pa**-pi-palu kaku **ci-sawmah-an** **ci-panay-an.** [AV-causative]
 AV-CAU-PI-hit 1SG.PIVOT **PN-Sawmah-Y** **PN-Panay-Y**
 ‘I asked Sawmah to hit Panay.’

(53) Seediq

- a. q<m><n>ita=ku Ø **iwan.** [simple AV clause]
 <AV><PRF>see=1SG.PIVOT **Y Iwan**
 ‘I saw Iwan.’
- b. Ø-**p**-huanguc=ku. Ø **iwan** Ø rodux nii. [AV-causative]
 AV-CAU-cook=1SG.PIVOT **Y Iwan** **Y** chicken this
 ‘I asked Iwan to cook this chicken.’

As seen above, across these four languages, Y-marking shows an ECM-behavior similar to English and Spanish causatives (47)-(48). In all cases, the Causee shares the same case-marking with transitive objects. This suggests that Y may realize structural Case, rather than lexical oblique Case, which is predicted to be available only to internal arguments. Therefore, unless the Y-marked Causee is licensed as an internal argument, an oblique Case analysis for Y is untenable. If the Causee is licensed as an embedded external argument, the availability of Y-marking on such arguments thus provides novel evidence for the accusative Case analysis of Y-marking. Whether the Y-marked Causee in AV-causatives is indeed licensed as an external argument is therefore key in determining the nature of Y-marking.

¹⁴ In Puyuma, Amis, and Seediq, the AV affix is null in productive causatives due to a phonotactic constraint that disfavors the bilabial sequence: *pa-* (causative prefix + AV infix) (Blust p.c.). In Tagalog (26a), the AV affix *nag-* is overt, as it does not have a bilabial onset. That the zero-marked causatives in (27)-(29) are indeed AV-causatives is shown by their shared argument-marking pattern with overtly-marked AV-sentences in Tagalog.

Existing work has shown that causative constructions across languages fall into three subtypes with regard to how the Causee is licensed. The first type exhibits a bi-clausal structure that contains an agentive Causee licensed as the embedded external argument (48), as attested in Japanese (Kuroda 1965; Shibatani 1976, Harley 2008), Hebrew (Cole 1976), Oromo (Owens 1985), Korean (Lee 1992), Tagalog (Maclachlan 1996; Travis 2000; Rackowski 2002), Eastern Armenian (Megerdooian 2005), Italian (Folli & Harley 2007), Hupa (Escamilla 2012), and Acehnese (Legate 2014). In this type of causative, the Causee is commonly analyzed as Case-licensed by the higher Voice⁰ through an ECM-configuration, as illustrated in (54). For the accusative analysis of Y to go through, we expect AV-causatives to bear this type of structure.

(54) Type I causatives: Bi-clausal with an agentive Causee

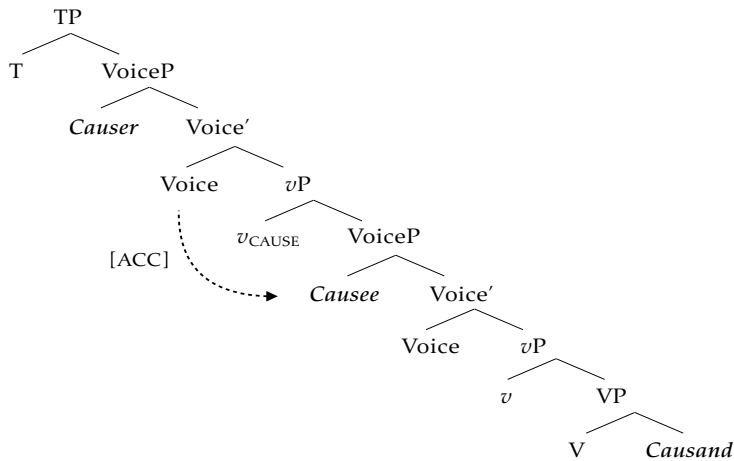

A second type of causative has been analyzed as employing a Causee licensed by an applicative phrase (55). As seen below, such causatives occur in mono-clausal constructions akin to ditransitive constructions, where the Causee is licensed as an applicative object structurally parallel to a Recipient in ditransitives. According to previous descriptions, the Causee in this type of causative shows non-agentive behaviors (e.g., Italian: Ippolito 2000; Folli & Harley 2007; Spanish: Tubino Blanco 2010; Acehnese: Legate 2014).

(55) Type II causatives

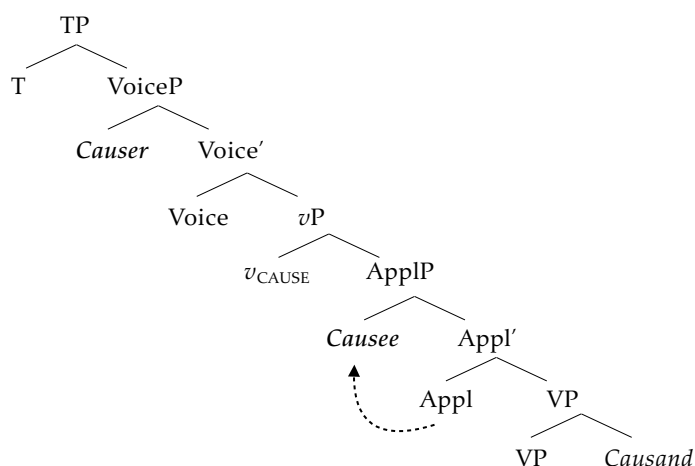

Yet a third type of causative has been shown to exhibit a Causee licensed as a by-phrase adjoined to the embedded verb phrase (56). As seen below, this type of causative construction exhibits a bi-clausal structure with a passivized embedded complement. As the Causee is licensed as a by-phrase, it does not behave like an external argument (e.g., French: Kayne 1975; Achenese: Legate 2014), similar to that in Type II causatives.

(56) Type III causatives

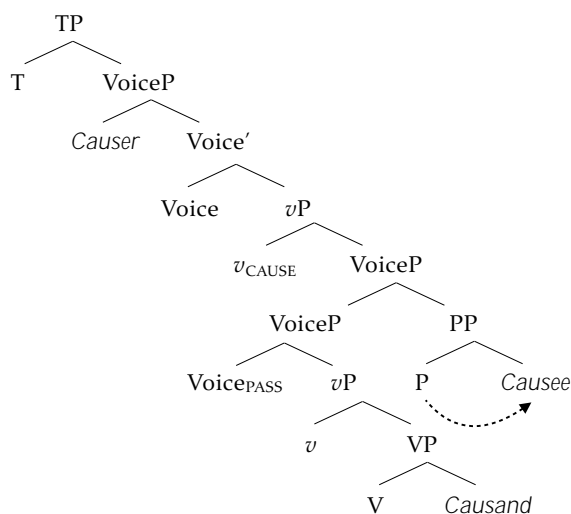

Crucially, none of these three types of causative (54)-(56) is compatible with a lexical Case analysis of the Causee. As all three constructions do not employ a lexical verb in the higher clause, it is untenable to assume that the Y-marking present on Causee realizes lexical oblique Case. It can thus be concluded that the presence of Y-marking on the Causee falsifies a lexical oblique Case analysis of Y.

However, to confirm an accusative Case analysis of Y, it is necessary to clarify the structure of AV-causatives. If AV-causatives exhibit a Type II or Type III structure (55)-(56), one may argue that the argument marker Y can be the morphological realization of both an inherent Case and a preposition on the Causee. Only if AV-causatives reflect a Type I structure we can confirm an accusative Case analysis for Y.

The structure of AV-causatives is examined with four standard diagnostics. As only Type I causatives employ an independent and active VoiceP for the caused event, Type I causatives are predicted to be the only type among the three that is compatible with agent-oriented adverbs that modify the causing event. The observation that AV-causatives across Puyuma, Amis, Seediq, and Tagalog are compatible with such adverbs (57a)-(d) thus points to a Type I analysis of these constructions:

- (57) Compatibility of the caused event with agent-oriented adverbs
- a. Ø-pa-pukpuk=ku kan siber **pakirep** kana suwan. [Puyuma]
 AV-CAU-hit=1SG.PIVOT SG.Y Siber **severely** DF.Y dog
 ‘I asked Siber to hit the dog severely.’ (Siber did so severely)
- b. Ø-pa-pi-tangtang kaku ci-panay-an t-una futing **pina’un**. [Amis]
 AV-CAU-PI-cook 1SG.PIVOT PN-Panay-Y Y-that fish **carefully**
 ‘I asked Panay to cook the fish carefully.’ (Panay did so carefully)
- c. Ø-p-sais=ku Ø akin **murux** Ø lukus. [Seediq]
 AV-CAU-sew-1SG.PIVOT Y Akin **independently** Y clothes
 ‘I asked Akin to sew the clothes independently.’ (Akin did so independently)
- d. nag-pa-nakaw ako kay ivan **nang palihim** ng keyk. [Tagalog]
 AV.PRF-CAU-steal 1SG.PIVOT PN.Y Ivan **CONJ secretly** ID.Y cake
 ‘I asked Ivan to steal the cake secretly.’

This analysis is strengthened by several other diagnostics. As Type I causatives are bi-clausal in structure, AV-causatives are predicted to be compatible with both (i) temporal adverbs and (ii) adverbs of frequency that independently modify the caused event. Both predictions are borne out with data across the four languages, except that Tagalog speakers found the sentence under the diagnostics of (i) unnatural (58d). See the data below in (58)-(59):

- (58) Compatibility of the caused event with a temporal adverb distinct from matrix aspect
- a. Ø-pa-trima=ku kan akang dra padraka **andaman**. [Puyuma]
 AV-CAU-buy=1SG.PIVOT SG.Y Akang ID.Y meat tomorrow
 ‘I asked Akang to buy meat tomorrow.’
- b. Ø-pa-pi-tangtang kaku ci-panay-an t-una futing **anucila**. [Amis]
 AV-CAU-PI-cook 1SG.PIVOT PN-Panay-Y Y-that fish **tomorrow**
 ‘I asked Panay to cook the fish tomorrow.’
- c. Ø-p-hanguc=ku Ø iwan **kusun** Ø sari. [Seediq]

AV-CAU-cook-1SG.PIVOT Y Iwan **tomorrow** Y taro
 ‘I asked Iwan to cook taro tomorrow.’

- d. ??**nag-pa-bili**=ako kay ivan ng isda **bukas**.¹⁵ [Tagalog]
 AV.PRF-CAU-buy=1SG.PIVOT PN.Y Ivan DF.Y fish **tomorrow**
 ‘I asked Ivan to buy fish tomorrow.’

(59) Compatibility of the caused event with the adverb of frequency ‘again’

- a. Ø-pa-base=ku kan senten **masal** kana kiping. [Puyuma]
 AV-CAU-wash=1SG.PIVOT SG.Y Senten **again** ID.Y clothes
 ‘I asked Senten to wash the clothes again.’ (Senten did so again)
- b. Ø-pa-pi-tangtang kaku ci-afan-an **heca** t-una tali. [Amis]
 AV-CAU-PI-cook 1SG.PIVOT PN-Afan-Y **again** Y-that taro
 ‘I asked Afan to cook the taro again.’ (Afan did so again)
- c. Ø-p-hanguc=ku Ø temi **dungan** Ø rodux. [Seediq]
 AV-CAU-cook-1SG.PIVOT Y Temi **again** Y chicken
 ‘I asked Temi to cook the chicken again.’ (Temi did so again)
- d. nag-pa-kanta=ako kay ivan ng kanta **ulit**. [Tagalog]
 AV.PRF-CAU-sing=1SG.PIVOT PN.Y Ivan DF.Y song **again**
 ‘I asked Ivan to sing the song again.’ (Ivan did so again)

If the current analysis is on the right track, the Y-marked Causee is licensed as an external argument that c-commands the Causand. Therefore, the Causee should be able to bind into the Causand. This prediction is borne out with both reflexivization and quantifier-variable binding tests, as in (60)-(61):

(60) Reflexivization between Causee and Causand in AV-causatives¹⁶

- a. Ø-pa-salretra’=ku kan sawagu **kantaaw**. [Puyuma]
 AV-CAU-cook=1SG.PIVOT DF.Y Sawagu **3SG.RFL.Y**
 ‘I asked Sawagu_{<i>} to slap himself_{<i>}.’
- b. Ø-pa-pi-nengneng kaku ci-sawmah-an **cingran-an tu**. [Amis]
 AV-CAU-PI-see 1SG.PIVOT PN-Sawmah-Y **3SG-Y RFL**
 ‘I asked Sawmah_{<i>} to look at herself_{<i>}.’
- c. Ø-p-tabak=ku Ø robo Ø **heya nanaq**. [Seediq]
 AV-CAU-slap=1SG.PIVOT Y Robo Y **3SG RFL**
 ‘I asked Robo_{<i>} to slap herself_{<i>}.’

¹⁵ I remain agnostic as to the asymmetry here between Tagalog and the other three languages. As the Tagalog speakers I consulted invariably approved the placement of an adverb of frequency that modifies the caused event (e.g., (53d)), I still analyze the construction as bi-clausal.

¹⁶ According to my Tagalog consultants, reflexivization is dispreferred in Tagalog AV-causatives. Nevertheless, AV-causatives in Tagalog are compatible with the other four diagnostics.

(61) Quantifier-variable binding between Causee and Causand in AV-causatives

- a. Ø-pa-deru=ku **kana taynaynayan driya** kantu=kuraw. [Puyuma]
 AV-CAU-cook=1SG.PIVOT **DF.Y mothers every** 3.POSS.Y=fish
 ‘I asked every mother_{<i><j>} to cook her_{<i><j>} fish.’
- b. Ø-pa-pi-tangtang kaku **tu cimacima a ina** tu titi nangra. [Amis]
 AV-CAU-PI-cook 1SG.PIVOT **Y every LK mother** Y pork 3PL.POSS
 ‘I asked every mother_{<i><j>} to cook her_{<i><j>} pork.’
- c. Ø-p-hanguc=ku Ø **knkingal bubu** Ø sari=daha. [Seediq]
 AV-CAU-cook=1SG.PIVOTY **every mother** Y taro=3PL.POSS
 ‘I asked every mother_{<i><j>} to cook her_{<i><j>} taros.’
- d. nag-pa-basa ako **sa bawat estudyante** ng kanyang=libro. [Tagalog]
 AV.PRF-CAU-read 1SG.PIVOT **DF.Y every student** ID.Y 3PL.POSS=book
 ‘I asked every student_{<i><j>} to read his/her_{<i><j>} book.’

Given the observations above, I conclude that AV-causatives in Puyuma, Amis, Seediq, and Tagalog invariably employ a Type I structure.¹⁷ Under this analysis, the Y-marked Causee is licensed at the embedded external argument position, where only structural accusative Case and not lexical oblique Case is available, as in (62). I conclude accordingly that the argument marker Y cannot realize lexical oblique Case. The facts outlined above are compatible only with an accusative Case analysis for Y.

(62) Case-licensing in Philippine-type AV-causatives

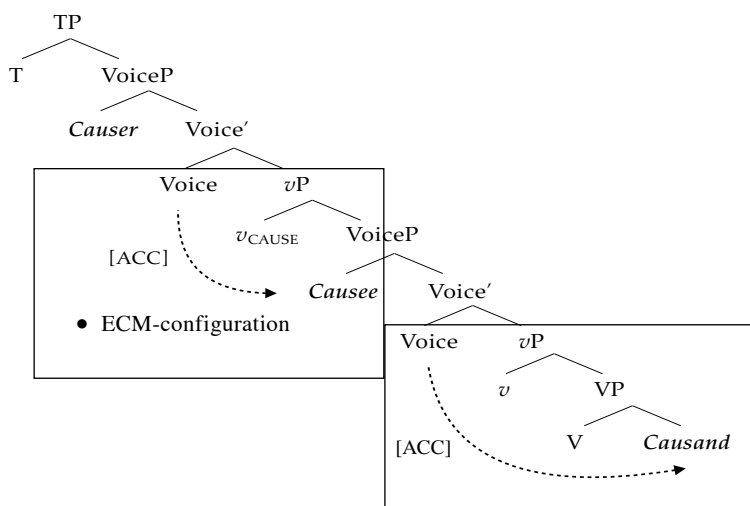

¹⁷ A bi-clausal analysis for Tagalog AV-causatives has also been proposed in Maclachlan (1996), Travis (2000), and Rackowski (2002). A similar analysis has been proposed for Tsou (Chang 2015), a Philippine-type language under a different Austronesian primary branch.

To summarize, the bi-clausal structure of AV-causatives suggests that Y can be licensed in both Head-Comp relation and ECM-configuration, as illustrated in (62). This behavior follows straightforwardly from a structural accusative Case analysis of Y-marking. Given the consistent argument-pattern of Y in productive causatives across Philippine-type languages, an oblique analysis of Y is difficult to maintain.¹⁸

2.5.2 Raising-to-object: The presence of Y in nonthematic position

I now turn to a second argument for the accusative analysis of Y-marking. Here, I will show that Y can appear in a specific environment where lexical Case is standardly analyzed as unavailable.

Raising-to-object (RTO) refers to a cline of constructions observed in typologically diverse languages. In theory-neutral terms, these constructions are characterized by allowing a phrase that is thematically linked to the embedded verb to optionally surface in the matrix object position (e.g., Japanese: Kuno 1976; Tanaka 2002; Moroccan Arabic: Massam 1985; Niuean: Massam 1985; Korean: Hong 1990, Yoon 2007; Passamaquoddy: Bruening 2001; Tsez: Polinsky & Potsdam 2001; Madurese: Davies 2005; Romanian: Alboiu & Hill 2013; Sundanese: Kurniawan 2012; Zulu: Halpert & Zeller 2015). As exemplified with data in (63), in Romanian, the subject of a finite embedded clause may optionally surface in the matrix object position without semantic consequences. In such constructions, the matrix verb ‘figure out’ shows accusative agreement with the “raised” phrase ‘Maria’ (63a), as if ‘Maria’ is a direct object of the matrix clause (63b).

(63) Romanian

- a. Am mirosit-**o** pe Maria [că voia să ne ntraga plasa].
 AUX.1 smell-CL.3SG.F.ACC DOM Maria [C want.PST SUBJ to.us draw net.the]
 ‘I figured out that Maria intended to con us.’ (Alboiu & Hill 2013:2)
- b. John-a văzut-**o** pe Maria.
 John-NOM see.PST-CL.3SG.F.ACC DOM Maria
 ‘John saw Maria.’

Previous work has revealed that RTO constructions vary across languages in terms of whether or not the “raised” phrase (henceforth the XP) undergoes an actual movement from the embedded clause. In constructions that involve an actual movement of the XP (64a), the XP is standardly analyzed as structurally Case-licensed by the matrix verb (e.g., Japanese: Kuno 1976; Tanaka 2002; Korean: Yoon 2007; Romanian: Alboiu & Hill 2013; Zulu: Halpert & Zeller 2015). In constructions that contain a base-generated XP at the “raised” position (64b), the XP is standardly analyzed as nonthematic, and its relation with the embedded clause is established through coindexation with an embedded pro (eg., Zacapoaxtla Nahuat: Higgins 1981; Madurese: Davies 2005; Sundanese: Kurniawan 2012; Cebuano: Davies 2005).

¹⁸ Note that it is untenable to assume the availability of structural accusative Case to the Causee in AV-marked causatives but not to the object in AV-marked simple clauses.

(64) Two types of RTO constructions

- a. Type I: XP underwent movement from the embedded clause

Voice⁰ ... V_{knowledge/perception} **XP_i** [CP/IP (C) V <**t_i**>]
↑_____↓

- b. Type II: XP being base-generated at the “raised” position

Voice⁰ ... V_{knowledge/perception} **XP_i** [CP/IP (C) V **pro_i**]

Crucially, neither type of RTO is compatible with the assumption that the XP is lexically Case-licensed by the matrix verb. In Type I constructions (64a), the XP is base-generated in the embedded clause. Therefore, it is obligatorily analyzed as θ -licensed by the embedded verb. In Type II constructions, the XP is standardly analyzed as lacking thematic identity with the matrix verb (see, e.g., Higgins 1981; Potsdam & Runner 2001; Davies 2005), for the reason that assuming the XP to receive a theta-role from the matrix verb will yield an infelicitous theta-grid (65):

(65) V_{knowledge/perception} <X_{Agent}, Y_{Theme}, Z_{XP}>

The theoretical issues surrounding the analysis in (65) are as follows. First, it requires an independently motivated lexical entry that licenses three θ -roles. Second, the alleged thematic role on the XP is difficult to classify. To avoid this undesirable θ -grid, previous studies have argued that XPs in Type II RTO are non-thematic (e.g. Higgins 1981; Potsdam & Runner 2001; Davies 2005).

As both types of RTO constructions are incompatible with a lexical oblique Case analysis for the case present on the XP, if the objects of AV clauses in Philippine-type languages share the same case-marking with the XP in RTO, we can conclude that Y does not realize oblique Case—as Y occurs in a position where lexical oblique Case is unavailable.

RTO constructions are attested in Philippine-type languages across all ten Austronesian primary branches, including Puyuma, Paiwan, Amis, Atayal, Seediq, Tsou, Kavalan, Saisiyat, Pazeh, Bunun, Rukai, Tagalog, Cebuano, and Malagasy.¹⁹ Across these languages, knowledge and perception verbs that select a finite clausal complement allow the embedded Pivot to optionally surface at the matrix object position, as in (66a)-(b):

(66) Puyuma RTO

- a. ma-tiya=ku [dra tu=trakaw-aw kan senten **ku=paysu**].
AV-dream=1SG.PIVOT [C 3.X=steal-PV SG.X Senten **1SG.POSS.PIVOT=money**]

¹⁹ Sources of RTO in specific languages are as follows: Paiwan (Wu 2013), Kavalan (Chang 2000); Bunun (Zeitoun 2000a), Saisiyat (M. Yeh 2000), Atayal (D. Liu 2011), Tsou (D. Liu 2011), Tagalog (Law 2010), Cebuano (Davies 2005), Malagasy (Paul & Rabaovolo 1998; Pearson 2001). More details about RTO in Puyuma, Amis, and Seediq can be found in V. Chen & Fukuda (2016b).

'I dreamt that Senten stole my money.'

- b. ma-tiya=ku **kanku=paysu** [dra tu=trakaw-aw kan senten ec_i(PIVOT)].
 AV-dream=1SG.PIVOT **1SG.POSS.Y=money** [C 3.X=steal-PV SG.X Senten ec_i(PIVOT)]
 'I dreamt that Senten stole my money.'

When the matrix verb is AV-marked, the XP in RTO obligatorily bears Y-marking. In other words, the XP lacks case-connectivity with the embedded clause. This is seen in (67)-(70):

(67) Puyuma

- a. ma-ladram=ku **kana bangsaran.**
 AV-know=1SG.PIVOT **DF.Y young.man**
 'I know that young man.'
- b. ma-ladram=ku **kana/*na** **ngiyaw_i** [dra karatr ec_i(PIVOT) kana suwan].
 AV-know=1SG.PIVOT **DF.Y/*DF.PIVOT** **cat** [C <AV>bite ec_i(PIVOT) DF.Y dog]
 'I know that the cat bit the dog.'

(68) Amis

- a. ma-fana' kaku **ci-sawmah-an.**
 AV-know 1SG.PIVOT **PN-Sawmah-Y**
 'I know Sawmah.'
- b. ma-fana' kaku **ci-sawmah-*(an)_i** [∅ mi-sakilif ec_i(PIVOT) ci-kulas-an].
 AV-know 1SG.PIVOT **PN-Sawmah-Y/*PIVOT** [C AV-lie ec_i(PIVOT) PN-Kulas-Y]
 'I know that Sawumah lied to Kulas.'

(69) Seediq (Truku)

- a. me-'isug=ku **∅ sinsi=mu.**
 AV-fear=1SG.PIVOT **Y teacher=1SG.POSS**
 'I am afraid of my teacher.'
- b. me-'isug=ku **ka imin-∅** [∅ s<m>ipaq huling=mu ec_i(PIVOT)].
 AV-fear=1SG.PIVOT **PIVOT Imin-Y** [C <AV>beat dog=1SG.POSS.Y ec_i(PIVOT)]
 'I fear that Imin will beat my dog.'

(70) Atayal: Shared Y-marking between AV object and XP in AV-marked RTO

- a. ma-'icuy **cu'** **'ulaqi'**_i ku' naβakis.
 AV-fear **Y child_i** PIVOT old.man
 'The old man is afraid of the child.'
- b. ma-'icuy **cu'** **'ulaqi'**_i ku' naβakis [CP 'i' r<um>akaap cu' βawak ec_i(PIVOT)].
 AV-fear **Y child_i** PIVOT old.man [CP C <AV>catch Y pig ec_i(PIVOT)]
 'The old man fears that the child may catch a pig.' (D. Liu 2011; glosses mine)

The case-marking pattern in (66)-(70) is summarized in (71). The XP is case-marked like an object of the AV clause. The fact that XP in AV-marked RTO constructions must bear Y-marking

(73) German long passives

... dass **die** **traktoren** zu reparieren versuch-t wurden.
... that **DET.NOM.PL tractor.PL** INF repair.INF try-PART AUX.PASS.PAST.PL
'... that they tried to repair the tractors.' (Wurmbrand 2001:19)

The “long-distance” Case-licensing phenomenon shown in (73) is known as a long passive, which is standardly analyzed as an outcome of a lack of a local structural Case-licensor within the embedded infinitival clause—either due to the deficient size of the embedded infinitive being smaller than a VoiceP (hence the lack of Voice⁰) or due to the functional deficiency of the embedded Voice⁰. Under the standard analysis, this lack of local Case-licensor forces the embedded internal argument to receive Case from the appropriate matrix Case-licensor, as illustrated in (74):

(74) Long-distance Case-licensing in German long passives

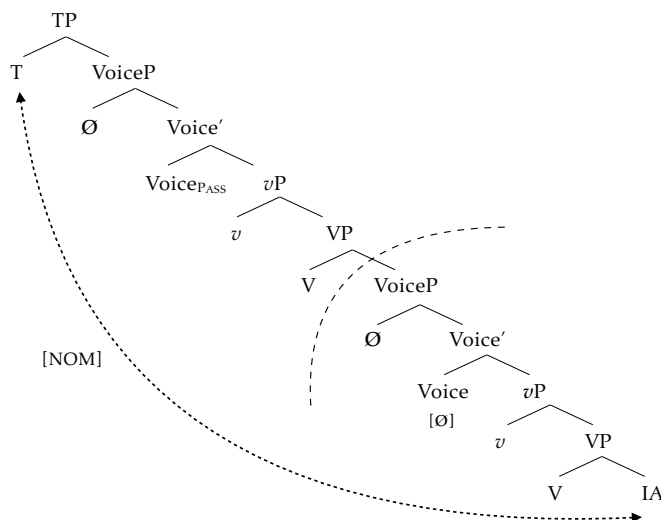

As seen in (74), inside a restructuring infinitive, a structural accusative Case licensor is supposed to be unavailable, whereas a lexical oblique licensor is predicted to present—given that the source of the latter is the lexical verb (V⁰). Whether or not Y-marking is available within restructuring infinitives therefore serves as a testing ground for the property of Y-marking.

According to available descriptions, restructuring phenomenon is attested in the majority Philippine-type Formosan languages (Puyuma, Amis, Kavalan, Atayal, Seediq, Paiwan, Takibakah Bunun, Saaroa, Pazeh) as well as in the Malayo-Polynesian language Kimaragang Dusun. In these languages, the complement embedded under an aspectual verb or try-type verb is obligatorily AV-marked, a morphological constraint known as “AV-only” (T. Chen 2010; Wurmbrand 2014). These embedded complements show characteristics typical of infinitival clauses, including (i) clitic climbing, (ii) inability to host aspect markers, and in some languages, (iii) the absence of a

complementizer, which is obligatorily present in finite embedded CPs. These traits are exemplified with the Puyuma data in (75)-(77) below :

(75) Obligatory AV-marking in Puyuma infinitives

tu=talam-ay=yu i senten [sapana'/*tu=sapana'-aw i sawagu].
 3.X=try-LV[PV] SG.PIVOT Senten [<AV>cheat/*3.X=cheat-PV SG.PIVOT Sawagu]
 'Senten tried to cheat Sawagu.'

(76) Clitic climbing in Puyuma infinitives

tu=talam-ay=*(yu) kan senten [sapana'(*=yu)].
 3.X=try-LV[PV]=*(2SG.PIVOT) SG.X Senten [<AV>cook/(**2SG.PIVOT)]
 'Senten tried to cheat you.'

(77) Aspect-deficiency and the obligatory absence of C in Puyuma infinitives

- a. ma-tiya i senten [(dra) da-deru dra patraka i sawagu].
 AV-dream SG.PIVOT Senten [(C) <AV>RED-cook ID.Y meat SG.PIVOT Sawagu]
 'Senten dreamt that Sawagu was cooking meat.'
- b. talam i senten [(**dra) deru/*da-deru dra patraka].
 try<AV> SG.PIVOT Senten [(**C) <AV>cook/*<AV>RED ID.Y meat]
 'Senten tried to cook/*was cooking the meat.'

Other than (i)-(iii), the internal argument inside the AV-marked embedded verb in these languages shows argument-marking in concord with the matrix voice marking. When the matrix verb is in AV, the internal argument must bear Y-marking; when the matrix verb is in PV, the internal argument must be Pivot-marked. This is seen in (78a)-(b). In all four examples, the matrix verb is PV-marked. The internal argument inside the AV-marked infinitive is obligatorily Pivot-marked, as if it is a direct object of the matrix PV-verb.

(78) The unavailability of Y-marking inside restructuring infinitives

- a. ku=talam-ay²⁰ [salem na/*dra ladru]. [Puyuma]
 1SG.X=try-LV[PV] [<AV>grow DF.PIVOT/ID.Y mango]
 'I tried to grow the mango.'
- b. talam-en aku [mi-tangtang kuna/*tuna titi]. [Amis]
 try-PV 1SG.X [AV-cook that.PIVOT/*Y pork]
 'I will try to cook that pork.'
- c. ququ-un=mu [m-imah ka/*∅ sino]. [Seediq]
 try-PV=1SG.X [AV-drink PIVOT/*Y alcohol]
 'I will try to drink the alcohol.'
- d. n-a-aw-i do kara [mangakan it togilay]. [Kimaragang]

²⁰ In Puyuma, some PV verbs are marked with a LV form, but select an internal argument (rather than a locative phrase) as the Pivot, including the verb 'try'.

PST-NVOL-finish-PV GEN monkey [AV.eat/*NAVPIVOT maize]
 ‘Monkeys finished off the maize eating.’ (Kroeger 2014:11)²¹

Given the presence of a lexical verb licenser (V) inside the embedded infinitives in (78a)-(d), the fact that the internal argument selected by the AV-marked embedded verb cannot bear Y-marking undermines a lexical oblique Case analysis of Y. Moreover, the absence of Y in these restructuring infinitives lends novel support for the structural accusative Case analysis of Y-marking, according to which the lack of the local structural accusative Case licenser forces the internal argument to receive appropriate argument-marking depending on matrix voice. As the matrix verbs in (79a)-(d) are in PV, the internal arguments are predicted to bear Pivot-marking, as normal PV objects do, parallel to German long passives (74).

This analysis is supported by the observation that the internal argument of AV-marked restructuring infinitive may undergo A'-extraction, just like a typical Pivot phrase:

- (79) A'-extraction of the Pivot-marked embedded Theme in PV-restructuring
- a. **amanay** [nu=t<in>alam **salem**?] [Puyuma]
stuff [2SG.X=<PV.PRF>try <AV>grow]
 ‘What did you try to grow?’ (What is the thing that you tried to grow?)
- b. **u maan** ku **mi-tanem-an** isu **mi-tangtang**? [Amis]
DET stuff PIVOT try-LV 2SG.X AV-cook]
 ‘What will you try to cook?’ (What is the thing that you will try to cook?)
- c. **maanu** ka **ququ-un=su** **m-imah**? [Seediq]
what PIVOT **try-PV=2SG.X** AV-drink
 ‘What will you try to drink?’ (What is the thing that you will try to drink?)

As languages that show this “exceptional case-marking” phenomenon in embedded infinitives represent nine of the ten Austronesian primary branches, a unitary accusative Case analysis of Y is well-supported.

To conclude, the obligatory absence of Y-marking in embedded infinitives reinforces a structural accusative Case analysis of Y. At the same time, it undermines a lexical Case analysis. Along with evidence from productive causatives and raising-to-object constructions, this leads to the conclusion that Y is better analyzed as structural accusative Case.

²¹ For the sake of consistency, I change the author’s gloss of ‘nominative’ into ‘Pivot’.

2.6 Detransitives: The compatibility of 2-place AV clauses with a detransitivizer

I have shown in the preceding section that the distribution of Y is compatible with an accusative Case analysis. In this section, I turn to a different piece of evidence that reinforces this analysis.

Since Burzio (1986), the availability of structural accusative Case in a clause has been standardly considered to be correlated with the presence of an external argument (see, e.g., Kratzer 1996; Pytkänen 2002; Harley 1995, 2013; Merchant 2008; Legate 2014).²² In this section, I demonstrate that there is an obvious correlation between the introduction of an external-argument and the availability of Y-marking in Philippine-type languages.

As discussed in Section 2.2, in Philippine-type languages, when a 2-place verb combines with an AV affix, both the external and internal arguments must be syntactically present. The external argument bears Pivot-marking and the internal argument is obligatorily Y-marked. Even if the external argument is occasionally omitted in natural speech, the internal argument cannot bear Pivot-marking. This is exemplified with the Puyuma and Tagalog data (80)-(81). For the purpose of the analysis presented in this subsection, I use the IPA symbols /t/, /d/, and /l/ for the Puyuma consonants that are otherwise presented as <tr>, <dr>, and <lr> throughout this dissertation. Here, IPA conventions make it easier to avoid mistaking <tr>, <dr>, and <lr> as representing consonant clusters.

(80) Puyuma
 {akaw *(i Senten) kana/*na={aʈuri. [2-place AV clause]
 <AV>steal (SG.PIVOT Senten) DF.Y/*DF.PIVOT=pen
 ‘Senten stole the pen.’

(81) Tagalog
 l<um>agda *(si Ivan) ng/*ang kontrata. [2-place AV clause]
 <AV>sign (SG.PIVOT Ivan) ID.Y/*PIVOT contract
 ‘Ivan signed a/the contract.’

The phenomenon to be investigated here concerns an underexplored construction found in three Philippine-type Formosan languages, Puyuma, Thao, and Bunun, each of which belongs to a different primary branch of Austronesian. In all three languages, when an AV-marked 2-place verb bears an additional prefix *u-*, the external argument is obligatorily absent, leaving the internal argument the sole argument in the clause ((82b), (83b), (84b)). In the following discussion, I call this construction the MU-construction.

²² Note, however, that this generalization has received some objections (see, e.g., Cuervo 2003; Hasegawa 2004). Nevertheless, as this generalization is still widely adopted in the mainstream theories and fits well into the argument-marking pattern of Philippine-type languages, I adopt this notion (as well as the notion of the division of Voice⁰ and v, which was built on top of this generalization) in this dissertation.

- (82) Puyuma
- a. **m-ekan** na walak kana kuraw. [AV clause, 2-place]
 AV-eat DF.PIVOT child DF.Y fish
 ‘The child ate the fish.’
- b. **m-u-ekan** la na/*kana kuraw. [MU-clause, 1-place]
 AV-U-eat PRF DF.PIVOT/*DF.Y fish
 ‘The fish is already eaten up.’
- (83) Thao
- a. *(caycuy) **m-rubuz** nak a taun. [AV-clause, 2-place]
 *(3PL.PIVOT) AV-demolish 1SG.POSS LK house.Y
 ‘They demolished my house.’
- b. *(caycuy) **m-u-rubuz** na ruza. [MU-clause, 1-place]
 *(3PL.PIVOT) AV-U-demolish DET boat.PIVOT
 ‘The boat broke down.’ (Blust 2003:843)
- (84) Bunun
- a. **ma-buhas** tama sibus. [AV-clause, 2-place]
 AV-snap.off father.PIVOT sugarcane.Y
 ‘Father snapped off a/the sugarcane.’
- b. **m-u-buhas** a sihi. [MU-clause, 1-place]
 AV-U-snap.off PIVOT branch
 ‘The tree branch (was) snapped off.’ (ODFL)

As seen above, with the presence of the affix *u-* on the verb, the external argument is obligatorily eliminated. The originally Y-marked internal argument in 2-place AV clauses (76a), (85a), and (86a) bears obligatory Pivot-marking, similar to the intransitive subject in an AV clause. This suggests that the internal argument in a MU-construction is the sole argument.

Consistent with its Pivot-marking, the internal argument in a MU-clause may undergo A'-extraction (85a), as opposed to the Y-marked internal argument in a 2-place AV clause (85b):

- (85) Puyuma
- a. barasa [RC na m-u-aḡas] [relativization from MU-clause]
 stone [RC LK AV-U-move]
 ‘the stone that has been moved’
- b. *barasa [RC na m-aḡas na bangsaran] [relativization of AV object]
 *stone [RC LK AV-move DF.PIVOT young.man]
 (Intended: ‘the stone which the young man moved’)

In this section, I will argue that the prefix *u-* is a detransitiver that realizes a deficient Voice⁰, which is independent from the AV affix *m-*. Following the standard assumption in recent work

(Kratzer 1996; Pylkkänen 2002; Harley 1995, 2013; Merchant 2008; Legate 2014), I assume that the deficient Voice⁰ (realized as *u-*) is incapable of licensing an external argument and assigning structural accusative Case. Therefore, both the external argument and Y-marking are absent in MU-constructions—as opposed to 2-place AV clauses, where both are present.

Building on this analysis, I argue that 2-place AV clauses must be true transitives that contain an accusative Case-licensed internal argument. The logic of this argument is simple: if 2-place AV clauses (e.g., (82a), repeated in (86a)) are antipassive constructions that contain only a core external argument, the MU-construction (e.g., (86b)) must be analyzed as having zero-valency, as the purported sole argument is eliminated with the presence of the affix *u-*. As this assumption is untenable, 2-place AV constructions (e.g., (86a)) must be true transitives.

(86) Puyuma

- a. **m-ekan** na walak kana kuraw. [AV clause, 2-place]
 AV-eat DF.PIVOT child DF.Y fish
 ‘The child ate the fish.’
- b. **m-u-ekan** la na/*kana kuraw. [MU-clause, 1-place]
 AV-U-eat PRF DF.PIVOT/*DF.Y fish
 ‘The fish is already eaten up.’

I will first present a detransitivizing analysis for MU-clauses (Section 2.6.1–2), and provide evidence that the sequence *mu-* is bi-morphemic, containing an AV affix *m-* and a detransitivizer *u-* (Section 2.6.3). In 2.6.4, I discuss how evidence from this construction reinforces a transitive analysis of 2-place AV clauses.

2.6.1 The detransitivizing analysis of the MU-construction

Across Puyuma, Thao, and Bunun, the sequence *mu-* is compatible with a large number of 2-place verbs, including both agent-oriented and canonical causative/inchoative verbs. See the examples in (87) and a sample list of verbs in (88):

(87) Puyuma

- a. **m-u-đimut** la na suwan. [agent-oriented verb]
 AV-U-catch PRF DF.PIVOT dog
 ‘The dog is caught.’
- b. **m-u-disdis** na kiping. [causative/inchoative verb]
 AV-U-tear DF.PIVOT clothes
 ‘The clothes tore.’

(88) TABLE 2.8. 2-place verbs compatible with a MU-construction in Puyuma, Thao, and Bunun²³

	Agent-oriented verbs	Causative/inchoative verbs
a. Puyuma	bury, carve, catch, cheat, cleave, comb, cook, cut, drink, eat, lock, pack, push, sell, open, squeeze, wash, weed	break, break down, burst open, burn, close, collapse, crack, extinguish, knot, loosen, sink, snap off, soak, tear
b. Thao	catch, catch in a trap, gash, gather, peel, scratch, surround, untie	break ₁ , break ₂ , break down, demolish, extinguish, fall into pieces, fall off, loosen, split wide open
c. Bunun	snap off, flip, spin, collect/gather, mash, pull up, scatter, untie	spray, loosen, demolish, fall off, break ₁ , break ₂

At first glimpse, the MU-construction resembles a passive both semantically and syntactically. However, further diagnostics suggest that it cannot be analyzed as a passive. Under the standard assumption, passives differ from detransitives in allowing an adjunct embedding a DP that bears the external theta role (Marantz 1984; Levin & Rappaport Hovav 1995; Reinhart 2000; Alexiadou et al. 2006). For the purposes of this chapter, I further assume that anticausatives are distinct from detransitives in that the former are restricted to causative/inchoative verbs (Haspelmeth 1993), whereas the latter apply to 2-place verbs in general. Under these assumptions, the MU-construction exhibits the typical traits of a detransitive.

This conclusion is built on the following diagnostics (e.g. Roeper 1987, Levin & Rappaport Hovav 1995, Alexiadou et al. 2006). First, crosslinguistically, passives allow an optional by-phrase that embeds a DP interpreted as the agent/initiator of the event, whereas detransitives and anticausatives do not. Second, detransitives and anticausatives occasionally allow the presence of an adjunct that embeds a cause, whereas passives do not. See the English and German examples in (89)-(90):

(89) English passives and detransitives

- a. The meat is cooked (by John). [passive]
 b. The meat cooked (*by John/from the sun). [detransitive]

(90) German passives and detransitives

- a. Die Vase wurde (✓von Peter) zerbrochen. [passive]
 the vase was (✓by Peter) broken
 'The vase was broken (by Peter).'
- b. Die Vase zerbrach (*von Peter/✓ durch ein Erdbeben). [detransitive]
 the vase broke (*by Peter/✓ through an earthquake)
 'The vase broke (*by Peter/through the earthquake).' (Alexiadou et al. 2006:184-5)

²³ Sources: Puyuma: Cauquelin (2015); primary data; Thao: Blust (2003b); Bunun: T. Lin (2001); ODFL.

A detransitive analysis of the MU-construction therefore follows from (i) its incompatibility with a by-phrase-like adjunct that embeds an animate complement, and (ii) the compatibility of a subclass of MU-constructions with an adjunct that embeds an inanimate cause. See the data in (91):

(91) Puyuma

- a. m-u-deru na paʔaka (*kana walak/*kan apeng/√ɔa kadaw).
 AV-U-cook DF.PIVOT meat (*DF.Y child /*SG.Y Apeng/√ID.Y sun)
 ‘The meat was cooked (*by the child/*by Apeng/from the sun).
- b. m-u-ʔual na aleban (*kana sinsi /*dra traw /√ɔa ba[i].
 AV-U-open DF.PIVOT door (*DF.Y teacher/*ID.Y person/√ID.Y wind)
 ‘The door opened (*by the teacher/*by someone/from the wind).
- c. m-u-sabesab na paʔiding (*kana walak/*kan sayki/√ɔa udal).
 AV-U-wash DF.PIVOT car (*DF.Y child /*SG.Y Sayki/√ID.Y rain)
 ‘The car was washed (*by the child/*by Sayki/from the rain).

A second argument for the detransitive analysis comes from the MU-construction’s incompatibility with agent-oriented adverbs. As observed crosslinguistically, passives but not detransitives can be modified by agent-oriented adverbs. See the English example in (92):

(92) English

- a. The boat was sunk deliberately [passive]
 b. *The boat sank deliberately. [detransitive]

Consistent with its incompatibility with by-phrases, the MU-construction cannot be modified by agent-oriented adverbs (93)-(94), as predicted by the detransitivization analysis:

(93) Puyuma

- a. ʔemakaw m-ekan na ngiyaw kana kuraw. [AV-construction]
 secretly AV-eat DF.PIVOT cat DF.Y fish
 ‘The cat ate the fish secretly.’
- b. (*ʔemakaw) m-u-ekan na kuraw. [MU-construction]
 (*secretly) AV-U-eat DF.PIVOT fish
 (Intended: ‘The fish was eaten secretly.’)

(94) Puyuma

- a. paleteng disdis na walak kantu=kaʔakaʔ. [AV-construction]
 deliberately <AV>tear DF.PIVOT child 3.POSS.Y=pants
 ‘The child tore his pants deliberately.’
- b. (*paleteng) m-u-disdis na kaʔakaʔ. [MU-construction]
 (*deliberately) AV-U-tear DF.PIVOT letter
 (intended: ‘The pants tore deliberately.’)

Finally, the current detransitive analysis makes a testable prediction, that intransitive verbs should not be able to form a MU-construction. This prediction is borne out by data from Puyuma. As seen in (95a)-(b), canonical unergative and unaccusative verbs are incompatible with the affix *mu-*:²⁴

(95) Incompatibility of the affix *mu-* with intransitive verbs

- a. *m-u-*{*kawang/*senay/*unkun} na [aw. [unergative-like verb]
 AV-DETR-{*walk/*sing/*jump} DF.PIVOT person
 (Intended: 'The person was walked/sang/jumped'.)
- b. *m-u-*{*redek/*ladu/*adalu} na [aw. [unaccusative-like verb]
 AV-DETR-{*arrive/*tumble/*slip} DF.PIVOT person
 (Intended: 'The person was arrived/tumbled/slipped'.)

The results from these three diagnostics thus indicate that the MU-construction exhibits the hallmarks of a detransitive.

2.6.2 The Seediq MU-construction and its implications

Our current analysis of the MU-construction has important implications for an understudied phenomenon in Seediq. According to primary data and Tsukida (2009:654), Seediq exhibits a perplexing argument structure alternation superficially formed by affixing either of two AV allomorphs, an infix *<m>* or a prefix *m-*, to the same 2-place verb. As seen in (96), when a 2-place verb is indexed with the infix *<m>*, it denotes a 2-place structure (96a); when the same verb is indexed with a prefix *m-*, it denotes a 1-place construction, with the external argument obligatorily absent (96b):

(96) Seediq

- a. wada h<m>urah ∅ pawan ka harac nii. [2-place clause]
 PRF <AV>collapse Y Pawan PIVOT stone.wall this
 'Pawan made this stone wall collapse.' (lit. 'Pawan collapsed this stone wall.')
- b. wada m-hurah ka sapah=mu. [1-place clause]
 PRF AV-collapse PIVOT house=1SG.POSS
 'My house collapsed.'

I argue that the *m*-marked 1-place construction in (96b) is a reflex of the MU-construction. Due to a vowel deletion process that has taken place in the Atayalic branch of Austronesian (Li 1980; Tsukida 2009; ACD), CV-initial words in Proto-Austronesian appear as C- in Seediq, with the vowel obligatorily eliminated. This rule applies consistently to prefixes, as illustrated in (97):

²⁴ Based on available materials on Thao (Blust 2003, ODFL), all attested cases of MU-constructions in the language are formed with 2-place verbs.

(97) TABLE 2.9. Instances of initial vowel deletion in Seediq

	Proto-Austronesian	reflex in Seediq	function
1	*Si-/Sa-	s-	circumstantial voice affix
2	*k<in>a-	k-n-	perfective prefix + stative prefix
3	*pa-	p-	causative prefix
4	*ni-	n-	perfective prefix
5	*Ca-reduplication	C-reduplication	reduplication for plurality

Given (97), the reflex of the detransitivizing sequence *mu-* in Seediq is predicted to be *m-*, with the vowel *u-* phonologically deleted, as observed exactly in (96b). That the *m*-marked 1-place clauses are indeed MU-constructions is evidenced by their consistent behavior as detransitive constructions, which allow the presence of an adjunct that embeds an inanimate cause but not an animate *by*-phrase, as seen in (98)-(99):

(98) Seediq

- a. wada s<m>etuq negul nii ka watan. [AV-construction]
 PRF break<AV> string this PIVOT Watan
 ‘Watan broke this string.’
- b. wada m-setuq (∅ bohu /*pais) ka hako=ta. [m- < PAn *mu-]
 PRF MU-break (Y typhoon/*enemy) PIVOT bridge=1PL.POSS
 ‘Our bridge broke (from a typhoon/*by the enemy).’

(99) Seediq

- a. wada d<m>engu qhuni ka dakis. [AV-construction]
 PRF roast<AV> wood PIVOT Dakis
 ‘Dakis heated the wood.’
- b. wada m-dengu (∅ [✓]bgihur mttilux/*dakis) ka qhuni. [m- < PAn *mu-]
 PRF MU-roast (Y [✓]hot wind /*Dakis) PIVOT wood
 ‘The wood was heated (from hot wind/*by Dakis).’

The finding in Seediq strengthens the proposal that the MU-construction is not likely to be a language-specific innovation, given its presence in languages across four different Austronesian primary branches (Puyuma, Western Plains, Bunun, Atayalic). Crucially, the Seediq data further suggests that the MU-construction can be traced back to Proto-Austronesian, prior to independent sound changes applied to specific languages.

2.6.3 MU- = AV affix *m-* + detransitivizer *u-*

Having confirmed the detransitive analysis of MU-constructions, I will demonstrate that the sequence *mu-* is bi-morphemic, containing an AV allomorph *m-* and a detransitivizer *u-*.

2.6.4.1 The bi-morphemic analysis of MU-

That *m-* and *u-* are independent from each other is first evident by the fact that the *m-* component in MU-constructions shares the same aspect-conditioned morphological alternation with canonical AV affixes. In Puyuma, the AV prefix *m-* is overt in the perfective and phonologically null in the future imperfective, as seen in (100a)-(b):

(100) Aspect-conditioned alternation of AV in Puyuma

- a. *m-ekan=ku* *la* *dra* *kuyan* *adaman.* [AV, perfective]
 AV.PRF-eat=1SG.PIVOT PRF ID.Y shrimp yesterday
 ‘I already ate shrimp yesterday.’
- b. \emptyset <*a*>*ekan=ku* *dra* *kuyan* *andaman.* [AV, future imperfective]
 AV<IMPF>eat=1SG.PIVOT ID.Y shrimp tomorrow
 ‘I will eat shrimp tomorrow.’

The same alternation is observed with the *m-* component in MU-constructions. In the perfective, the MU-construction presents the affixation *m-u-* ((101a), (102a)); in the future imperfective ((101b), (102b)), only the affix *u-* is morphologically present. Crucially, the external argument in the U-marked imperfective clause ((101b), (102b)) remains obligatorily absent, as is that in the MU-marked perfective clause (101a). This indicates that the affix *u-* is independent from the AV affix *m-*, and is responsible for the elimination of the external argument.

(101) Aspect-conditioned morphological alternation of *m-* in Puyuma MU-constructions

- a. *m-u-sapana'* *la* *i* *akang.* [perfective]
 AV-DETR-cheat PRF SG.PIVOT Akang
 ‘Akang was cheated.’
- b. \emptyset -*u*-<*a*>*sapana'*=*yu.* [future imperfective]
 AV-DETR<IMPF>cheat=2SG.PIVOT
 ‘You will be cheated.’

(102) Aspect-conditioned morphological alternation of *m-* in Puyuma MU-constructions

- a. *m-u-ʔekel* *na* *eraw.* [perfective]
 AV-DETR-drink DF.PIVOT alcohol
 ‘The alcohol was drunk up.’
- b. \emptyset -*u*-*a-ʔekel* *na* *eraw.* [future imperfective]
 AV.-DETR<IMPF>drink DF.PIVOT alcohol
 ‘The alcohol will be drunk up.’

A second argument for the AV-affix analysis of *m-* comes from a well-known fact of Philippine-type languages, that every clause must employ a voice affix. Therefore, if the sequence *mu-* is analyzed as a mono-morphemic detransitivizer that contains no voice-indicating affix, the MU-clauses would be an exception to an otherwise well-motivated generalization. Furthermore, the fact that the MU-construction obligatorily employs a Pivot-marked subject additionally suggests that the *m-* component must be an AV affix, given the generalization that only with the presence of an AV affix will the morphological marking ‘Pivot’ fall on the subject of a clause (e.g., Rackowski 2002, Blust 2013).

Finally, it is important to note that the *m-* component in MU-clauses follows directly from the predicted distribution of the allomorphs of a canonical AV affix. As illustrated in (103), an AV affix appears in prefix form when preceding a vocalic base. Therefore, it is expected to surface in the form *m-* when combining with the detransitivizer *u-*. This analysis is confirmed with data from Puyuma and Thao. As seen in (104a) and (105a), when an AV affix is attached to consonant-initial verbs, it appears in infix form in canonical AV clauses ((104b), (105b)). When the AV affix occurs in the MU-construction, it surfaces as the *m-* allomorph, consistent with the allomorphic rule in (103):

(103) AV * <um> → *m- / ___V

(104) Puyuma: 2-place verb with consonant-initial base

- a. {}ima i siber dra kiping. [AV-construction]
 <AV>sell SG.PIVOT Siber ID.Y clothes
 ‘Siber sold clothes.’
- b. m-**u**-tjima la na kiping. [MU-construction]
 AV-DETR-sell PRF DF.PIVOT clothes
 ‘The clothes were sold out.’

(105) Thao: 2-place verb with consonant-initial base

- a. yaku t<m>uqris takic. [AV-construction]
 1SG.PIVOT <AV>catch.with.a.nose.trap barking.deer.Y
 ‘I caught a barking deer with a snare trap.’
- b. m-**u**-tuqris Ø iza na lhizashan. [MU-construction]
 AV-DETR-catch.with.a.nose.trap PIVOT this LK pheasant
 ‘The pheasant is caught with a snare trap.’ (Blust 2003:1020)

On the other hand, when an AV affix combines with vowel-initial or liquid-initial verbs in Thao (79)-(80), it consistently surfaces as a prefix in both canonical AV-clauses and MU-clauses, since both constructions fall under the allomorphic condition in (103).²⁵ Therefore, in such cases, the AV affix *m-* in AV-constructions ((106a), (1017)) and the sequence *m-u-* in MU-clauses ((106b), (107b))

²⁵ Besides the rule in (8), Thao employs a language-specific allomorphic rule that the AV infix <*m*> will appear in prefix form when preceding liquid-initial bases (Blust 2003:44), as seen in (37a).

form a minimal pair and denote a 2-place and 1-place structure, respectively, lending further support to the analysis that the affix *u-* is independent from *m-* and responsible for the detransitivization operation.

(106) Puyuma: 2-place verb with vowel-initial base

a. **m-a-aleb** i kuadur kana aleban . [AV-construction]
 AV<IMPF>close SG.PIVOT Kuadur DF.Y door
 ‘Kuadur is closing the door.’

b. **m-u-aleb** na aleban. [MU-construction]
 AV-DETR-close DF.PIVOT door
 ‘The door is closed.’

(107) Thao: 2-place verb with liquid-initial base

a. yaku a ma-kan fizfiz, **m-ruqit** shapa. [AV-construction]
 1SG.PIVOT LK AV-eat banana, AV-peel skin
 ‘I will eat a banana, peel its skin.’ (Blust 2003:848)

b. nak a kuskus **m-u-ruqit**. [MU-construction]
 1SG.POSS LK leg AV-DETR-scratch
 ‘My leg is scratched.’ (Blust 2003:848)

2.6.4.2 The structure and Case-licensing in MU-clauses

I argue that the detransitivizing affix *u-* in MU-constructions realizes a defective Voice⁰, which is capable of licensing neither an external argument nor structural Case to its internal argument (e.g., Chomsky 2000, 2001a, b; Legate 2003, 2014; Wurmbrand 2001). Since the defective Voice⁰ is not a Case licenser, the internal argument in MU-clauses checks nominative Case with T (108):

(108) Proposed structure and Case-licensing in the MU-construction

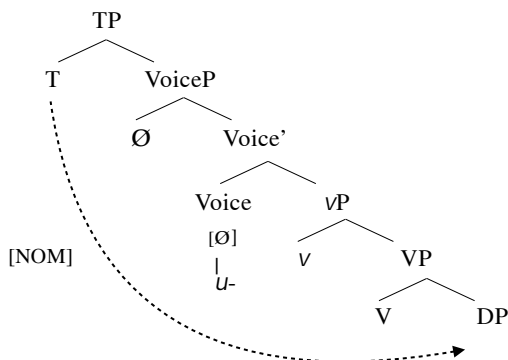

The present proposal correctly captures the characteristics of the MU-construction, including its lack of an external argument and inability to license a *by*-phrase, as well as the affix *u*’s incompatibility with both canonical unergative and unaccusative verbs. Crucially, if this analysis is on the right track, it presents a direct argument against the intransitive Voice⁰ analysis of the AV affix. Given that the detransitivizing affix *u*- is the reflex of Voice⁰, we can conclude that the AV affix *m*-, which co-exists with *u*- in MU-constructions, cannot be analyzed as realizing Voice⁰.

2.6.4 The nature of Philippine-type Actor voice: Evidence from the MU-construction

To sum up, evidence from the MU-construction has shown that Philippine-type AV affixes may appear in 2-place clauses as well as in detransitives and intransitives, as seen in (109a)-(c):

- (109) The distribution of the AV affix in Puyuma
- a. *m*-a-abel | i | aʔung | ɖa | ku[ang]. [transitive]
 AV<PROG>cook SG.PIVOT Atrung ID.Y vegetable
 ‘Atrung is cooking vegetables.’
 - b. *m*-u-ʔeke | la | na | eraw. [detransitive (MU-clauses)]
 AV-DETR-drink PRF DF.PIVOT alcohol
 ‘The alcohol was drunk up.’
 - c. *m*-u-arak | i | aʔung | i | arasip. [intransitive]
 AV-dance SG.PIVOT Atrung LOC Arasip
 ‘Atrung danced in Arasip.’

Given that 2-place AV-clauses are compatible with the detransitivizer *u*-, I argue that they must be analyzed as true transitives with a core object. Under this analysis, a 2-place AV clause employs a transitive Voice⁰ that assigns both an external argument and structural accusative Case to its internal argument (e.g. Kratzer 1996, Pylkkänen 2002, Cuervo 2003, Harley 1995, 2013, Merchant 2008, Legate 2014), as in (110):

- (110) Case-licensing in 2-place AV-clause

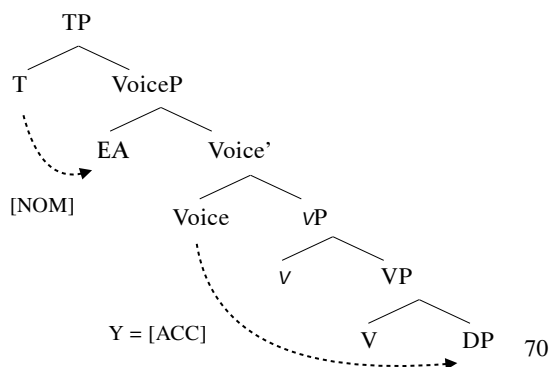

This analysis follows consistently from an important trait of Philippine-type 2-place AV clauses, that the internal argument in 2-place AV clauses cannot be omitted, unlike antipassive objects. Furthermore, it accounts for a shared constraint observed across Philippine-type languages, that the marker Y is not available to the internal argument of canonical unaccusative verbs, as in (111b). Under the accusative Case analysis of Y, this observation is straightforwardly accounted for, as accusative is a dependent Case.

(111) Puyuma: Argument-marking in unaccusative clauses

- a. [akaw i sawagu *(da paysu).
steal<AV> SG.PIVOT Sawagu *(ID.Y money)
'Sawagu stole money.'
- b. ma-[adu na/*kana walak. [unaccusative]
AV-slip DF.PIVOT/*DF.Y child
'The child slipped.'

A final question in the present analysis lies in the nature of the AV affix *m-*, whose distribution has been shown to be insensitive to the transitivity of a clause. At this stage, I conclude that the AV affix is not a marker of intransitivity (reflex of intransitive Voice⁰), and is best viewed as a verbal affix that correlates with the Pivot status on the first argument of a clause. The nature of the affix will be discussed in Chapter 5.

2.7 Conclusion and implications

Given the evidence from the four constructions discussed in 2.5–6, I conclude that 2-place AV clauses are true transitives, rather than antipassives. Under this analysis, the internal argument of AV clauses is licensed with structural accusative Case from Voice, as in (112):

(112) Case-licensing in 2-place AV-clause

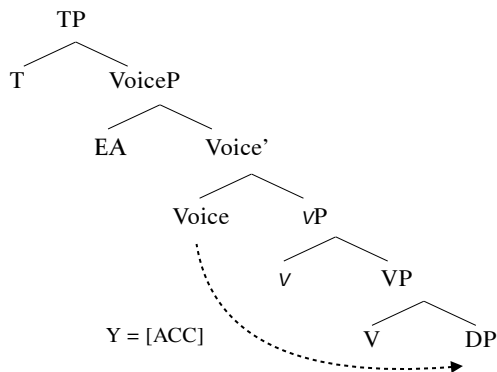

This analysis provides a straightforward account for two observations discussed in the preceding sections: First, AV objects cannot be omitted, and second, AV clauses lack an antipassive marking for the purported valency decreasing operation.

Under the new picture obtained from the present analysis, Philippine-type languages do not manifest ergativity at either the morphological or syntactic level, as S, A, and O may all access Pivot-marking and undergo A'-extraction (113):

(113) TABLE 2.10. Argument-marking pattern in Philippine-type AV and PV clauses

	1-place AV clauses	2-place AV clauses	(2-place) PV clauses
External argument	Pivot (S)	Pivot (A)	X (A)
Internal argument	—	Y (O)	Pivot (O)

I argue accordingly that Y cannot be analyzed as lexical oblique Case, but is better analyzed as marking structural accusative Case. The comparative evidence for the four constructions is summarized in (114):

(114) TABLE 2.11. Evidence for a transitive analysis of Philippine-type 2-place AV clauses

	a. Causatives	b. RTO	c. Restructuring	d. Detransitives
1. Atayalic	✓	✓	✓	✓
2. Bunun	✓	✓	✓	✓
3. East Formosan	✓	✓	✓	
4. Tsouic	✓	✓	✓	
5. Western Plains	✓	✓	✓	✓
6. Northwest Formosan	✓	✓	✓	
7. Paiwan	✓	✓	✓	
8. Puyuma	✓	✓	✓	✓
9. Rukai	✓	✓	—	✓
10. Malayo-Polynesian	✓	✓	✓	

Given the transitivity of 2-place AV clauses, I conclude that Philippine-type AV clauses can either be transitive or intransitive, depending on the semantic properties of the verb. This conclusion has two important implications. First, Philippine-type languages do not exhibit ergativity at either the syntactic or morphological level. Second, Philippine-type “voice” alternation differs from the notion of “voice” in Indo-European languages—which is associated with valency rearranging. Both implications will be revisited in Chapter 3 for further investigation of the nature of the Philippine-type voice system.

Chapter 3

The nature of the argument marker X

Previous analyses of Philippine-type languages commonly assume that the argument marker X, which appears on the external argument in non-Actor voice clauses, is a marker of agentivity present only in transitive clauses. Under this assumption, X has been analyzed as inherent ergative case assigned by transitive verbs. Its absence in 2-place AV clauses relies crucially on the assumption that AV constructions are syntactically intransitive. Now, given the transitive analysis of 2-place AV clauses presented in Chapter 2, the function and distribution of X in AV and PV clauses is an issue that warrants reexamination.

In this chapter, I demonstrate that the distribution of X is incompatible with an ergative Case analysis, but follows directly from a nominative Case analysis. Support for this claim comes from two observations: First, the distribution of X is neither tied to the external argument position nor to transitive clauses; second, it is subject to locality condition and limited to one occurrence per CP. I conclude that X shows the hallmarks of structural Case from C/T. This analysis, along with the accusative Case analysis of Y in Chapter 2, suggests that Philippine-type languages exhibit a nominative-accusative case system. Finally, it calls for a reexamination of the nature of “Pivot”-marking, which is conventionally analyzed as nominative/absolute Case.

3.1 Introduction

I have argued in Chapter 2 that Philippine-type 2-place AV clauses are true transitives that contain an accusative Case-licensed internal argument. This conclusion brings us to the argument-marking pattern in (1), which calls for a reexamination of the nature of the argument marker X.

(1) TABLE 3.1. The argument-marking alternation between Philippine-type AV and PV clauses

	a. Actor voice	b. Patient voice
External argument	<i>Pivot</i>	X
Internal argument	Y = Accusative	<i>Pivot</i>

The distribution of X illustrated in (1) is exemplified with the Paiwan and Tagalog examples.¹ As seen below, X-marking is obligatorily present on the external argument in PV clauses ((2b), (3b)). However, it cannot mark the external argument in AV clauses ((2a), (3a)):

(2) *Paiwan*²

- a. kac a/***nua** 'atjuvi tua watu. [AV]
 bite<AV> PIVOT/***x** snake Y dog
 'The snake bit a dog.'
- b. kac-in a watu **nua**/*a 'atjuvi. [PV]
 bite-PV PIVOT dog **x**/*PIVOT snake
 'The snake bit the dog.' (Chang 2006:113–4)

(3) *Tagalog*

- a. p<um>atay si/***ni** ivan kay viktoría. [AV]
 kill<AV> PN.PIVOT/***PN.X** Ivan PN.Y Victoria
 'Ivan killed Victoria.'
- b. pa-patay-in **ni**/*si **ivan** si viktoría. [PV]
 CONT-kill-PV **PN.X**/*PN.PIVOT **Ivan** PN.PIVOT Victoria
 'Ivan will kill Victoria.'

Much previous work has attributed the distribution of X to an alleged transitivity distinction between AV and PV clauses. Under this analysis, X realizes ergative Case available only in transitive clauses, hence its absence in purportedly intransitive AV clauses (e.g., Payne 1982; Mithun 1994; Ross 2002; Aldridge 2004, 2008, 2011; Liao 2004; Chang 2011). Now, given the conclusion from Chapter 2 that 2-place AV clauses are true transitives as are PV clauses, the asymmetrical distribution of X-

¹ As briefly discussed in Chapter 2, many Philippine-type languages have lost the morphological distinction between X and Y in common noun marking, but preserve it in pronominal paradigm and personal name marking. One typical example is Tagalog (a) (McFarland 1976). Nevertheless, an X/Y distinction (see the Paiwan paradigm in (b)) is attested in conservative languages under different Austronesian primary branches and is reconstructable to Proto-Austronesian together with the Philippine-type voice system (Ross 2006; Blust 2015).

a.	Common noun	Personal name	1st singular	2nd singular	3rd singular	[Tagalog]
Pivot	<i>ang</i>	<i>si</i>	<i>ako</i>	<i>ikaw</i>	<i>siya</i>	
X	ng	<i>ni</i>	<i>ko</i>	<i>mo</i>	<i>niya</i>	
Y	ng	<i>kay</i>	<i>akin</i>	<i>iyo</i>	<i>kaniya</i>	

b.	Common noun	Personal name	1st singular	2nd singular	3rd singular	[Paiwan]
Pivot	<i>a</i>	<i>ti</i> (sg.)	<i>tiaken</i>	<i>tisun</i>	<i>tiamadju</i>	
X	nua	<i>ni</i> (sg.)	<i>niaken</i>	<i>nisun</i>	<i>nimadju</i>	
Y	tua	<i>tjay</i> (sg.)	<i>tjanuaken</i>	<i>tjanusun</i>	<i>tj(a)iamadju</i>	

More details of the prototypical argument-marking pattern of Philippine-type languages can be found in Appendix IV.

² Similar to Puyuma, Paiwan allows flexible word order among nominals (Chang 2006). In Chang's original data, (2a) and (2b) happen to show different word orders.

marking between AV and PV clauses in (1) requires a new account. In this chapter, I reexamine the nature of X-marking, and argue for the analysis in (4):

- (4) X marks structural nominative Case, rather than inherent ergative Case. It occurs once per CP and is assigned to the highest Caseless phrase in finite clauses.

This chapter is organized as follows. In Section 3.2, I outline the predictions of the competing analyses regarding the distribution of X in Philippine-type languages. In Sections 3.3 and 3.4, I discuss the distribution of X in two specific constructions, lending new support to a nominative Case analysis of X. In Section 3.3, I show that the distribution of X can be dissociated from both the external argument position and transitive clauses, an observation that goes against the ergative Case analysis of X. In Section 3.4, I further show that the distribution of X is subject to locality and finiteness, and is unique per clause, traits which follow directly from a nominative Case analysis. I conclude accordingly that X marks structural nominative Case, and is difficult to fit into a conventional ergative Case analysis. In Section 3.5, I discuss the implications of the current analysis for a recent proposal that Philippine-type languages exhibit split ergativity. Section 3.6 concludes.

3.2 The competing analyses

In this section, I outline the competing analyses, and discuss their prediction of the distribution of X in Philippine-type languages. In 3.2.1, I summarize the core assumptions of the ergative Case analysis of X as proposed by previous works. In 3.2.2, I put forward an alternative nominative Case analysis of X. In 3.2.3, I discuss the the predicted distribution of X under the two analyses.

3.2.1 The inherent ergative Case analysis of X

As introduced in Chapter 1, Philippine-type Austronesian languages share the basic argument-marking pattern in (5). As seen below, X is obligatorily absent on the external argument of AV clauses, and it is obligatorily present on that of non-AV clauses.

- (5) *TABLE 3.2. The shared argument-marking pattern across Philippine-type languages*

	(a) AV	(b) PV	(c) LV	(d) CV
External argument	Pivot/*X	X	X	X
Internal argument	(Y)	Pivot	(Y)	(Y)
Location	(Loc)	(Loc)	Pivot	(Loc)
Instrument/benefactor	(Y)	(Y)	(Y)	Pivot

The distribution of X in (5a)-(d) is conventionally attributed to the assumption in (6):

(6) *A transitivity-based account for the distribution of X-marking*

In Philippine-type languages, all non-AV-marked clauses are *transitive*, whereas all AV clauses are *intransitive*. (Payne 1982; Mithun 1994; Aldridge 2004 et seq.)

This assumption is widely adopted in a family of ergative analyses of Philippine-type languages (e.g., De Guzman 1976; Payne 1982; Mithun 1994; Huang 2001; Aldridge 2004, 2008, 2011, 2016a, b; Liao 2004; Chang 2011, 2013, 2015; Wu 2013) and in a number of descriptive works (see, e.g., Ross 2002; Teng 2008; Wu 2015). Under this assumption, a well-received proposal by Aldridge (2004 et seq.) has maintained that the source of X is transitive v (equivalent to Voice⁰ in the framework adopted in this study).

Under this analysis, X realizes inherent ergative Case assigned by transitive v (henceforth Voice⁰) to the external argument in transitive clauses, as in (7). For the sake of consistency, I indicate the source of X as transitive Voice⁰, which is equivalent to transitive v in Aldridge (2004 et seq.). Note that this difference does not affect the analysis discussed here.

(7) *The nature of X-marking under the ergative approach to Philippine-type languages*

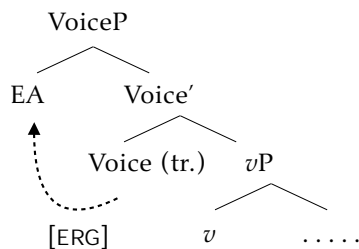

Under (7), the Case-licensing mechanism in PV clauses is as follows: first, the external argument receives ergative Case from transitive Voice⁰, following the standard assumption that nonstructural Cases are licensed prior to structural Cases (e.g. Marantz 1993; Bobaljik 1998; Woolford 2006; Preminger 2011). Due to the proposed EPP feature on transitive Voice⁰, the internal argument then undergoes Object Shift, raising to the outer specifier of VoiceP, where it checks structural absolutive Case with C/T (Aldridge 2004, 2008, 2011, 2017)³. This is diagrammed in (8):

³ In Aldridge's earlier work (2004, 2008, 2011), the source of absolutive Case is Asp⁰. In her more recent work (2016a, b, 2017), Aldridge puts forward a revised proposal that Philippine-type languages lack Feature Inheritance (Richards 2008; Chomsky 2008; Miyagawa 2010), whereby the source of absolutive Case is C.

(8) *The ergative approach to Case-licensing in PV clauses*

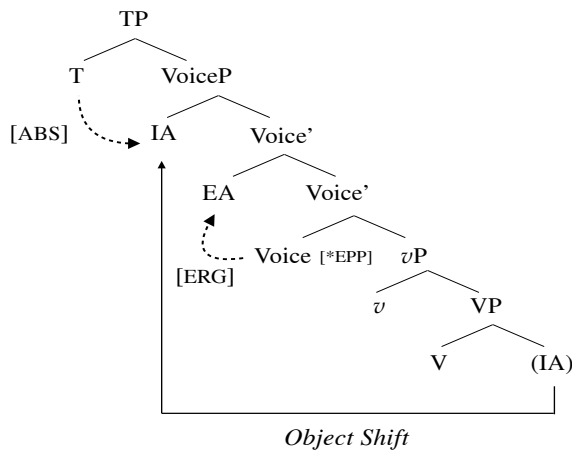

Under this proposal, X-marking is not licensed in AV clauses, as AV clauses are assumed to employ intransitive Voice⁰, which is incapable of licensing inherent ergative Case to its specifier. Thus, the external argument checks structural absolutive Case from C/T, and the internal argument is Case-licensed with oblique Case from the lexical verb (V), as in (9):

(9) *The ergative approach to Case-licensing in PV clauses*

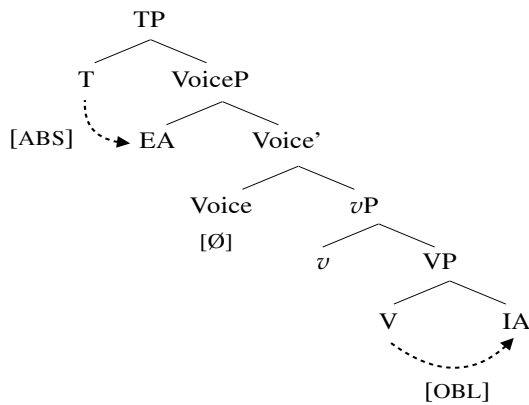

3.2.2 Claim: X marks structural nominative Case

Contra the conventional analysis summarized in 3.2.1, I argue that X marks nominative Case. Under this analysis, the source of X is finite T, which licenses structural Case to the highest Caseless DP in a finite clause.

If this analysis is on the right track, in clauses that contain a transitive or unaccusative verb, X is predicted to mark the external argument (10a); in those that contains an unaccusative verb, it is predicted to mark the internal argument (10b):

(10) *Case-licensing of structural nominative Case*

- a. *In transitive/unergative clauses* b. *In unaccusative clauses*

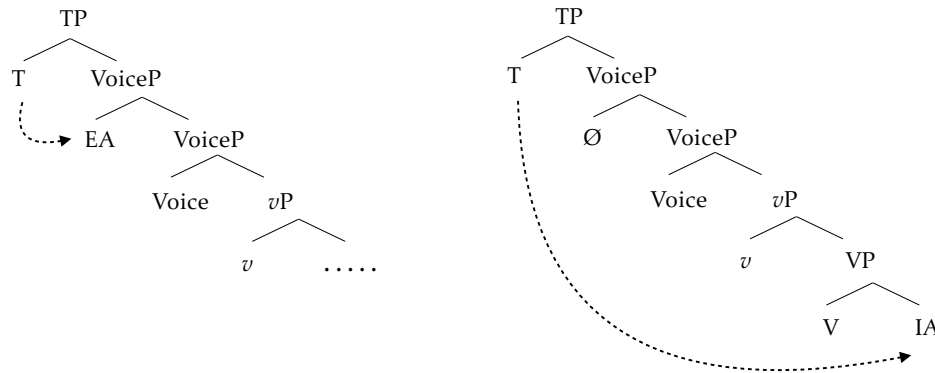

In what follows, I outline how the two competing analyses make different predictions about the distribution of X-marking.

3.2.3 The competing analyses and their predictions for the distribution of X

Under the ergative Case analysis, X is assigned by transitive Voice⁰ to the specifier of VoiceP. This analysis predicts that the distribution of X is restricted to (i) *external argument position* and (ii) clauses that contain a *transitive verb*. As a single clause may contain multiple VoicePs, multiple X-marking is predicted to be possible within a CP.

Alternatively, if X marks nominative Case, the source of X is finite T. Therefore, X-marking is predicted to be unique per CP and available only to the structurally highest Caseless phrase in finite clauses. Therefore, multiple X-marking is predicted to be impossible within a single finite clause. On the other hand, as illustrated previously in (10), the distribution of X should not be tied to a specific structural position, but is available to both external and internal argument positions.

The predictions of these two competing analyses are summarized in (11). In the following sections, I present two independent arguments in favor of the nominative Case analysis of X. In Section 3.3, I show that the distribution of X is neither restricted to the external argument position nor conditioned by transitivity (11a)-(b). In Section 3.4, I show that X-marking is unique per CP, regardless of the number of VoiceP available in a clause (11c)-(d).

(11) *TABLE 3.3. Predictions of the competing analyses*

	X = ergative Case	X = nominative Case
a. X is restricted to external arguments	✓	—
b. X is restricted to transitive clauses	✓	—
c. X can appear once per CP	—	✓
d. X must appear on the highest Caseless phrase	—	✓

3.3 Observation 1: The distribution of X is insensitive to transitivity, and applies outside the external argument position

As discussed in 3.2, under the ergative Case analysis, X is predicted to appear only in transitive clauses and the external argument position. In this section, I demonstrate that the distribution of X in fact departs from these predictions.

3.3.1 The presence of X in unaccusative-like constructions

In Puyuma, Amis, Seediq, and Tagalog, typical unaccusative verbs can be marked with Locative or Circumstantial voice affixes when the sentence contains a Locative or Reason phrase, as in (12)-(13). In such cases, the Locative or Reason phrase will bear “Pivot”-marking, and the Theme-like argument selected by the verb is obligatorily X-marked:

(12) *X-marking on undergoer in LV-marked unaccusative sentences*

- a. **tu_i=atel-ay kandri na barasa_i na ruma’.** [Puyuma]
3.X_i=fall-LV X.this LK stone_i DF.PIVOT house
 ‘This stone fell on the house.’
- b. **ka-tulu’-an aku/*takuwanan kuna lalan.** [Amis]
slip-LV 1SG.X/*Y PIVOT.that road
 ‘I slipped on that road.’
- c. **h-huqil-an na/*Ø riso nii ka Paran.** [Seediq]
RED-die-LV X/*Y young.man this PIVOT Paran
 ‘This young man will die in Paran.’
- d. **h<in>ulug-an niya/*kanya ang balon.** [Tagalog]
fall<PRF>-LV 3SG.X/3SG.Y PIVOT well
 ‘He/she fell in the well.’⁴

(13) *X-marking on undergoer in CV-marked unaccusative sentences*

- a. **tu_i=i-kualeng na tr<in>ekel-an draeraw.** [Puyuma]
3.X_i=CV-be.sick PIVOT <PRF>drink-LV ID.Y alcohol

⁴ It is noteworthy that a potential asymmetry seems to exist among native speakers’ interpretation of LV-marked unaccusative verbs between Puyuma/Amis/Seediq and Tagalog. In the former three languages, LV-marked unaccusative verbs do not bear intentional reading. The Tagalog example (12d) comes from an online entry of Tagalog literature <https://ibongadarnanowna.wordpress.com/ang-pagkahari-ng-reyno-de-los-cristales/>. According to my Tagalog consultant, the context of the sentence indicates that the falling event is accidental. However, one of my consultants reported that (12d) has an intentional meaning. Therefore, there seems to be inter-speaker variation with regard to the interpretation of these LV-marked constructions.

'He got sick from drinking alcohol.'

- b. **sa-pi-patay ni kulas/*-an** ku pitamaku. [Amis]
CV-TR-die X Kulas/*-Y PIVOT smoking
 'Kulas died from smoking.'
- c. **s-k<n>-narux na/*Ø temi** ka knrudan=na. [Seediq]
CV-STAT<PRF>sick X/*Y Temi PIVOT age=3SG.POSS
 'Temi got sick because of her age.'
- d. **i-k<in>a-matay niya/*kanya** ang sakit. [Tagalog]
CV-STAT<PRF>die 3SG.X/3SG.Y PIVOT sickness
 'He/she died of illness.'

In order for the ergative Case analysis of X to go through, two assumptions are necessary for the constructions in (12)-(13). First, the unaccusative-like verbs 'die', 'fell', and 'be tired' must be transitive. Second, the Theme-like arguments selected by 'die', 'fell', and 'be tired' must be licensed as external arguments. Both assumptions contradict the standard analysis of unaccusative constructions, according to which the sole argument selected by the intransitive verb is licensed in the internal argument position, as in (14):

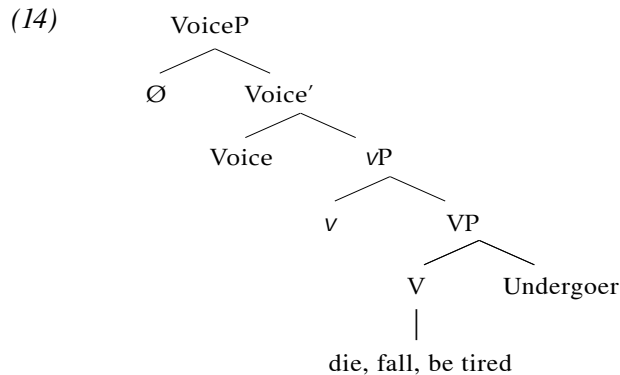

If the constructions in (12)-(13) indeed possess a structure like (14), these constructions raise two theoretical issues problematic for the conventional analysis of X-marking. First, as inherent ergative Case is assumed to be licensed in Head-Spec relation to the external argument position, the availability of X on the internal argument suggests that X cannot mark inherent ergative Case.

Second, as the unaccusative constructions (12)-(13) are untenable to be analyzed as transitive, the presence of X-marking in such constructions suggests that the source of X cannot be transitive Voice⁰. It is important to note here that the validity of this argument has no direct correlation with which specific analysis is assumed for the structural position of the Pivot phrases in these constructions. Whether one analyzes the Pivot-marked Locative/Reason phrases in (12)-(13) as applied objects (15a) or adjuncts (15b) (which I will argue to be the case in Chapter 4), the lexical

verb invariably selects only one argument and not two, as applied objects are standardly analyzed as licensed by the applicative phrase (15a), rather than by the lexical verb.

(15) *Two analyses of the structure of the unaccusative clauses with a Locative/Reason phrase*

a. *The high applicative analysis*

b. *The adjunct analysis*

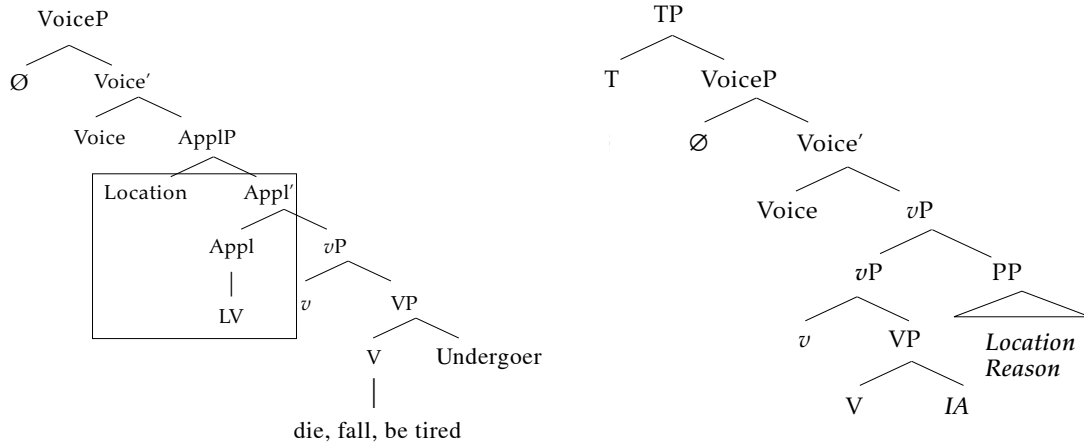

Therefore, under either an applicative or adjunct analysis of the Pivot, a transitive analysis of the unaccusative verbs in (12)-(13) is difficult to maintain.

3.3.2 Unaccusativity in Puyuma, Amis, Seediq, and Tagalog

Given the discussion above, the key question in clarifying the nature of X-marking thus boils down to whether the X-marked Theme-like arguments in (12)-(13) are indeed licensed as internal arguments.

Since Perlmutter (1978) and Burzio (1986), it has been widely assumed that intransitive subjects in many languages fall into two subtypes with regard to their base-generated position. This is known as the *Unaccusativity hypothesis* (16):

(16) *The Unaccusativity Hypothesis*

Unergative and unaccusative verbs are syntactically differentiated. The former have nonderived subjects, whereas the surface subjects of the latter originate as direct objects.

Working under the hypothesis in (16), it is standardly assumed in the framework of the Minimalist Program that unergative verbs license their sole argument at the external argument position (17a), whereas unaccusative verbs introduce the argument at the internal argument position (17b):

(17) *The structural position of unergative and unaccusative subjects*

a. *Unergative*

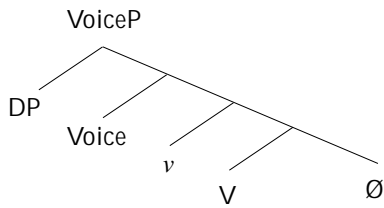

b. *Unaccusative*

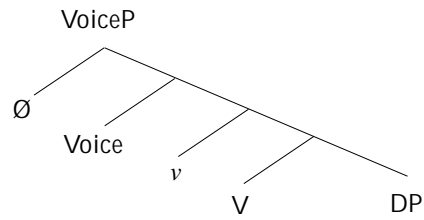

Therefore, if unaccusativity is manifested in Puyuma, Amis, Seediq, and Tagalog, the Theme-like arguments in the unaccusative-like constructions in (12)-(13) are licensed as internal arguments. The availability of X-marking on such arguments will thus argue against the inherent ergative Case analysis of X, which predicts that X is available only to the external argument position.

In the following subsections (3.4.1.1–3), I present three independent lines of evidence for the presence of unaccusativity in Puyuma, Amis, Seediq, and Tagalog.

3.3.2.1 *Evidence from the morphological distinction of AV affixes*

Puyuma, Amis, and Seediq all show a rough division in their AV morphology which distinguishes between unergative and unaccusative verbs (18):

(18) *TABLE 3.4. Morphological distinction in the AV affix in Puyuma, Amis, and Seediq*

	Unaccusative verbs	Unergative/transitive verbs
a. Puyuma	<i>m-u</i> ⁵	
b. Amis	<i>ma-</i>	<um> (unergative), <i>mi-</i> (transitive)
c. Seediq	<i>m-</i>	<m>

Despite some sporadic irregularities, the pattern in (29) is general enough to posit an unergative/unaccusative distinction in these three languages. A similar morphological distinction is less clear in Tagalog, despite previous claims that the AV infix <um> in Tagalog is associated with unergatives and the prefix *ma-* with unaccusatives (Foley 2005:425; Kaufman 2009:32).

⁵ In Puyuma, many instances of causative/inchoative alternation are formed with the affixation vs. *m-u*- (detransitivizing operation). When a causative/inchoative verb is affixed with , the sentence is 2-place, with the Causer and the Theme licensed as external and internal arguments, respectively, as in (a). When the same verb is affixed with *m-u*-, only the Theme is present, as in (b). See also Chapter 2.6 for a discussion of the *MU*-construction.

(a) disdis na walak dra tigami. (b) m-u-disdis na tigami.
 tear<AV> DF.PIVOT ID.Y letter AV-DETR-tear DF.PIVOT letter
 'The child tore the letter.' 'The letter (was) torn.'

3.3.2.2 Asymmetry in compatibility from cognate object constructions

The second argument for the presence of unaccusativity in these four languages comes from the asymmetry between unergative- and unaccusative-like verbs in forming cognate object constructions.

Cognate object, or *cognate accusative* (see Levin 1993; Jones 1988; Massam 1990; Hale & Keyser 1997) refers to a phenomenon in which a number of intransitive verbs allow the optional presence of an object that is lexically related to the verb. This phenomenon has been attested in typologically diverse languages including Arabic, Chinese, English, French, Hebrew, Icelandic, Korean, Spanish, Russian, and Vietnamese. See the following examples from English (18), Icelandic (19), and Vietnamese (20):

- (19) a. John *smiled* (a bitter *smile*). [English]
b. Mary *dreamt* (a sweet *dream*).
c. Sally *danced* (a joyful *dance*).

- (20) Hann *dreymd* hálfan *drawm*. [Icelandic]
he dream.PST half dream.ACC
'He *dreamt* a half *dream*.' (Svenonius 2001:16)

- (21) no *cuoi* [nu *cuoi* *khieukhich*]. [Vietnamese]
he smile [CLF smile provocative]
'He *smiles* a provocative *smile*.' (Pham 1999:227)

Most cognate object constructions are known to be associated with unergative verbs, and are incompatible with unaccusative verbs (e.g., Massam 1990; Levin & Rappaport Hovav 1995; Macfarland 1995; Mittwoch 1998, Felser & Wanner 2001). This is known as the *Unergative Restriction* (Kuno & Takami 2004:107), and can be observed in the grammaticality contrast between the English examples (18) and (21):

- (22) a. *The glass *broke* a crooked *break*. (Levin & Rappaport Hovav 1995)
b. *The apples *fell* a smooth *fall*. (Levin & Rappaport Hovav 1995)
c. *The snow *melted* a slow *melt*. (Macfarland 1995)

Macfarland (1995) and subsequent work has argued that the Unergative Restriction is a direct outcome of the hypothesized structural difference between unergative and unaccusative subjects (22): as cognate objects are licensed at the internal argument position (22a), they are incompatible with unaccusative constructions, since the the sole argument selected by unaccusative verbs occupies the

same position, as seen in (22b). The asymmetry in licensing a cognate object between unergative- and unaccusative-like verbs can thus serve as a diagnostic for unaccusativity.⁶

(23) *Account of the Unergative Restriction in cognate object constructions*

a. *Unergatives*

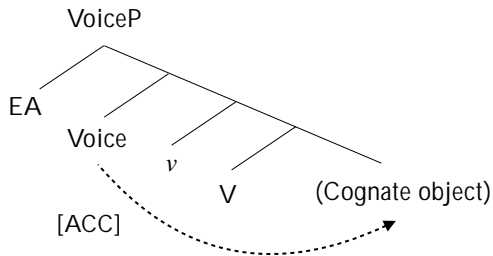

b. *Unaccusatives*

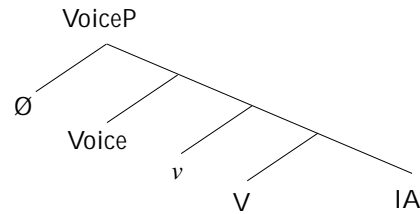

According to primary fieldwork, cognate object constructions are attested across Puyuma, Amis, Seediq, and Tagalog. In all four languages, a number of canonical unergative verbs allow the presence of a Y-marked object that is lexically affiliated with the verb stem (e.g., ‘sing’, ‘dance’, ‘dream’). This is exemplified in (23)-(24):

(24) *Cognate object construction with the verb ‘dream’*

- a. ma-**tiya** i senten (dra tulruwa na **tiya**). [Puyuma]
 AV-**dream** SG.PIVOT Senten (ID.Y three LK **dream**)
 ‘Senten *dreamt* three *dreams*.’
- b. ma-**lemed** ci-sawmah (tu lima a **lemed**). [Amis]
 AV-**dream** PN.PIVOT-Sawmah (Y five LK **dream**)
 ‘Sawmah *dreamt* (five *dreams*).’
- c. m<n>-**sepi** (Ø **sepi** teru) ka robo. [Seediq]
 AV<PRF>-**dream** (Y **dream** three) PIVOT Robo
 ‘Robo *dreamt* (three *dreams*).’
- d. na-**naginip** si ivan (ng **panaginip**). [Tagalog]
 AV.PRF-**dream** PN.PIVOT Ivan (ID.Y dream)
 ‘Ivan *dreamt* a *dream*.’

(25) *Cognate object construction with the verb ‘dance’*

- a. m-**uarak** i sayki (kana **uakaran** i drekalr.). [Puyuma]
 AV-**dance** SG.PIVOT Sayki (DF.Y **dance** LK tribe)
 ‘Sayki *danced* (the *dance* of the tribe).’

⁶ Note that recent work (e.g. Kuno & Takami 2004) has showed that some unaccusative verbs are able to license cognate objects. This observation, however, is not necessarily damaging for the Unergative Restriction. See Nakajima (2006) and subsequent work for evidence that the cognate objects present in unaccusative constructions are licensed as adjuncts.

- b. ma-sakeru ci-lisin (tu lima a keru). [Amis]
 AV-dance PN.PIVOT-Lisin (Y five LK dance)
 'Lisin danced (five dances).'
- c. k<m><n>eeki (Ø keeki teru) ka iwan. [Seediq]
 <AV><PRF>dance (Y dance three) PIVOT Iwan
 'Iwan dance (three dances).'
- d. nag-sayaw si ivan (ng sayaw). [Tagalog]
 AV.PRF-dance PN.PIVOT Ivan (ID.Y dance)
 'Ivan danced a dance.'

Based on primary data, all attested cases of cognate object constructions are formed with typical unergative verbs. Similar constructions formed with canonical unaccusative verbs were not attested. Further, such constructions were rejected by speakers of all the four languages in grammaticality judgement tests, exemplified with the examples in (26):

(26) *Unavailability of a cognate object construction with unaccusative verbs*

- a. ma-ladu i sawagu (*dra saya dra ladu). [Puyuma]
 AV-fall SG.PIVOT Sawagu (*ID.Y one LK fall)
 'Sawagu fell (*a fall).'
- b. ma-patay cingra (*tu fangcal a patay). [Amis]
 AV-die 3SG.PIVOT (*Y good LK death)
 'He died (*a peaceful death).'
- c. m<n>takur (*Ø takur) ka walis. [Seediq]
 <AV><PRF>slip (*Y slip) PIVOT Walis
 'Walis slipped (*a slip).'
- d. na-buwal ang puno (*ng biglang buwal). [Tagalog]
 AV.PRF-fall PIVOT tree (*ID.Y sudden fall)
 'The tree fell (*a sudden fall).'

The asymmetry in compatibility with a cognate object between canonical unergative and unaccusative verbs thus suggests the presence of an unergative/unaccusative distinction across Puyuma, Amis, Seediq, and Tagalog.

3.3.2.3 *Evidence from the asymmetry in licensing adjuncts that embed a Cause*

The third argument for unaccusativity in the four languages comes from an asymmetry between typical unergative and unaccusative verbs in their compatibility with adjuncts that embed a cause.

It is widely observed that unaccusative verbs across languages are compatible with adjuncts that embed a cause, as seen in (27a)-(b). Unergative verbs cannot combine with this type of adjunct,

- b. t<um>angitc (*nu lunen) ku wawa. [Amis]
 cry<AV> (Y earthquake) PIVOT child
 'The child cried (*from the earthquake).
- c. l<m><n>ingis (*Ø bruwa) ka laqi. [Seediq]
 cry<AV><PRF> (Y thunder) PIVOT child
 'The child cried (*from the thunder).
- d. um-iyak ang bata (*sa kulog). [Tagalog]
 AV-cry PIVOT child (DF.Y thunder)
 'The child cried (*from the thunder).

Along with the observations on cognate object constructions, the above asymmetry reinforces the presence of an unergative/unaccusative distinction in the four languages.

3.3.3 X marks nominative Case

Given the evidence discussed in 3.3.2.1–3, I conclude that unaccusativity is manifested in Puyuma, Amis, Seediq, and Tagalog. This suggests that the sole argument selected by unaccusative verbs such as those presented in (12)-(13) (partially repeated in (30)) is indeed licensed as an internal argument, as illustrated in (30).

(30) *X-marking on undergoer in LV-marked unaccusative sentences*

- a. **tu_i=atel-ay kandri na barasa_i** na ruma'. [Puyuma]
3.X_i=fall-LV X.this LK stone_i DF.PIVOT house
 'This stone fell on the house.'
- b. ka-**tulu'-an aku/*takuwanan** kuna lalan. [Amis]
slip-LV 1SG.X/*Y PIVOT.that road
 'I slipped on that road.'
- c. h-**huqil-an na/*Ø** riso nii ka Paran. [Seediq]
 RED-**die-LV X/*Y** young.man this PIVOT Paran
 'This young man will die in Paran.'
- d. h<in>**ulug-an ni/*kay** ivan ang swimming pool. [Tagalog]
fall<PRF>-LV PN.X/PN.Y Ivan PIVOT swimming.pool
 'Ivan fell into the swimming pool.'⁹

⁹ My Tagalog consultant commented that (30d) has an intentional reading. However, this interpretation is not found in corresponding sentences in Puyuma, Amis, and Seediq.

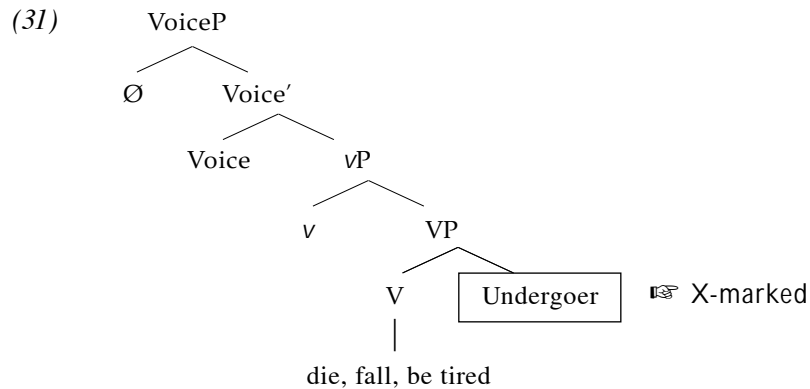

The fact that the internal arguments illustrated in (31) are accessible to X-marking thus lends to two important implications: First, X cannot be analyzed as inherent ergative Case, as inherent ergative Case is assigned in Spec-Head relation to the external argument position. Second, the source of X is not transitive Voice⁰, as the unaccusative verbs in (30)-(31) cannot be analyzed as transitive. Both observations argue against the proposed properties of X-marking that are necessarily assumed under the ergative approach to Philippine-type languages.

The two generalizations above, on the other hand, are compatible with a nominative Case analysis of X. First, as the distribution of nominative Case is not tied to a specific structural relation, the internal argument in (30) is predicted to be accessible to nominative Case as long as it is the structurally highest argument in the clause (see Chapter 4 for further discussion).¹⁰ Second, as nominative Case is not sensitive to the transitivity of a clause, it is predicted to be available in both transitive and intransitive clauses, including the unaccusative constructions in (30).

Finally, the fact that the internal argument in (30) cannot be Y-marked reinforces the accusative Case analysis of Y-marking as argued in Chapter 2. As accusative is a dependent Case, which is available only in transitive clauses, it is predicted to be unavailable in the unaccusative construction in (30). The ergative approach to Philippine-type languages, on the other hand, wrongly predicts that the internal argument in (30) will receive lexical oblique Case (i.e., Y-marking) from the verb. The observation that the internal argument in (30) can only be X-marked and not Y-marked thus lends support to our current analysis of X and Y.

3.4 Observation 2: X is unique per CP and subject to locality

I now turn to the second argument for the nominative Case analysis of X. As discussed in Section 3.2, if X marks nominative Case, it is predicted to occur once per CP and be available only to the highest Caseless phrase in a finite clause. Alternatively, if X marks inherent ergative Case, it is not necessarily limited to one occurrence per CP whenever multiple VoicePs are present in a single

¹⁰ Briefly, if the nominative Case analysis of X is on the right track, we expect that the Pivot-marked locative phrases in (30) are not structurally higher than the X-marked internal argument. This prediction will be verified in Chapter 4.

clause. In this section, I show that the distribution of X follows directly from a nominative Case analysis.

3.4.1 The structure and argument-marking pattern in AV- and CV-causatives

According to primary fieldwork and available descriptions, Philippine-type languages share the following argument-marking pattern in productive causatives:

(32) TABLE 3.5. *The shared argument-marking pattern in productive causatives*

	a. AV	b. PV/LV	c. CV
Causer	Pivot	X	X
Causee	Y/* X	Pivot/* X	Y/* X
Causand	Y	Y	Pivot

Two observations can be made about Table 3.5. First, when a productive causative construction is not AV-marked, X-marking falls on the Causer. Second, X-marking is not available to a Causee, regardless of voice-marking. To investigate the nature of X, I will focus on the structure of AV- and CV-causatives, whose Causees are obligatorily Y-marked and cannot be X-marked.

I will first clarify the structure of AV- and CV-causatives. As a bi-clausal analysis of AV-causatives in Puyuma, Amis, Seediq, and Tagalog has been presented in Section 3.2.5.1, I do not repeat it here. Below I present evidence that CV-marked causatives (32c) share the same structure with AV-causatives.

As discussed in Chapter 2, in a bi-clausal causative construction, the caused event is licensed as an independent VoiceP. The caused event in such constructions is therefore compatible with (i) agent-oriented adverbs, and (ii) adverbs of frequency.

Both predictions are borne out with CV-causatives across the four languages. As shown by examples in (33)-(34), the caused event in CV-causatives is compatible with both (i) and (ii):

(33) *Compatibility of agent-oriented adverbs with the caused event in CV-causatives*

- a. ku=pa-pukpuk-**anay** kan sawagu **pakirep** na suwan. [Puyuma]
 1SG.X=CAU-hit-CV SG.Y Sawagu **severely** DF.PIVOT dog
 'I asked Sawagu to hit the dog severely.'
- b. **sa**-pa-pi-tangtang aku cingranan t-una futing **pina'un**. [Amis]
 CV-CAU-PI-cook 1SG.X 3SG.Y Y-that fish **carefully**
 'I asked her to cook the fish carefully.'
- c. **s**-p-sais=mu Ø temi **murux** ka lukus. [Seediq]
 CV-CAU-sew=1SG.X Y Temi **alone** PIVOT clothes
 'I asked Temi to sew the clothes independently.' (Temi did so without help)

- d. *i-p<in>a-ayos=ko kay ivan ang kotse nang palihim.* [Tagalog]
 CV-CAU<PRF>-repair=1SG.X PN.Y Ivan pivot car CONJ secretly
 'I asked Ivan to repair the car secretly.' (Ivan did so secretly)

(34) *Compatibility of adverbs of frequency with the caused event in CV-causatives*

- a. *ku=pa-pukpuk-anay kan senten masal na suwan.* [Puyuma]
 1SG.X=CAU-hit-CV SG.Y Senten again DF.PIVOT dog
 'I asked Senten to hit the dog again.' (Senten did so again)
- b. *una maeded-ay a wacu, sa-pa-pi-palu heca aku ci-kulas-an.* [Amis]
 that bad-NMZ LK dog CV-CAU-PI-hit again 1SG.X PN-Kulas-Y
 'That bad dog, I asked Kulas to hit (it) again.' (Kulas did so again)
- c. *s-p-pahu=mu Ø dakis dungan ka lukus nii.* [Seediq]
 CV-CAU-wash=1SG.X Y Dakis again PIVOT clothes this
 'I asked Dakis to wash the clothes again.' (Dakis did so again)
- d. *i-p<in>a-sulat=ko ulit ang liham kay viktoría.* [Tagalog]
 CV-CAU<PRF>-write=1SG.X again PIVOT letter Y Victoria
 'I asked Victoria to write the letter again.' (Victoria did so again)

Given the observations above, I conclude that CV-causatives across these four languages employ a bi-clausal structure, just as AV-causatives do. In both constructions, the Causee is licensed as an embedded external argument, as in (35):

(35) *The bi-clausal structure of AV- and CV-causatives in the four sample languages*

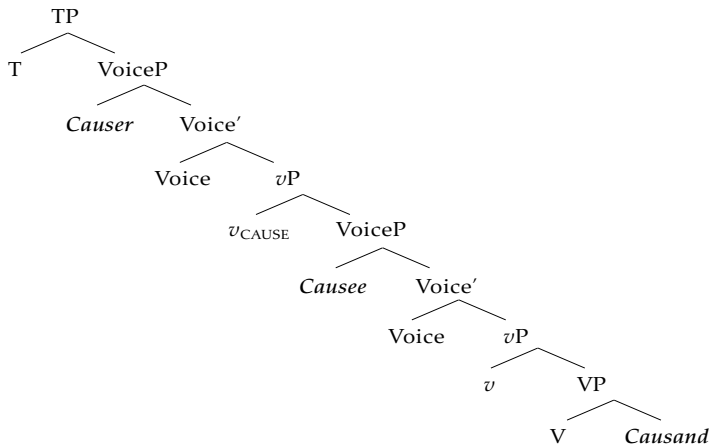

In the following subsection, I discuss how the distributional restriction of X in these causative constructions presents novel evidence for the nominative Case analysis of X.

3.4.2 The distributional restriction of X in productive causatives

Under the inherent ergative Case analysis of X, X-marking is predicted to be available to all external argument positions where *transitive Voice*⁰ is present. Therefore, in bi-clausal causatives, X-marking should be available to both the *Causer* and the *Causee*—given that both arguments are licensed as an external argument.

This prediction is supported by observations from a number of genetically diverse ergative languages, including Macushi (Carib), Trumai (isolate), Kabardian (Caucasian), Qiang (Tibeto-Burman), and Agul (Caucasian). Each of these languages allows ergative-marking on both the *Causer* and the *Causee* (Abbott 1991; Abitov et al. 1957, Guirardello 1999; LaPolla & Huang 1996). See the data below from Trumai (isolate), Kabardian (Caucasian) and Macushi (Carib):

(36) *Ergative-marked Causee in Trumai productive causatives*

alaweru-k **hai-ts** axos disi-ka.
 Alaweru-ERG **1sg-ERG** child.ABS hit-CAU
 'Alaweru made me hit the child.' (Guirardello 1999)

(37) *Ergative-marked Causee in Kabardian productive causatives*

l'əžə-m !'"**la-m** χəd`abzə-r yə-r-yə-ğa-h-ā-ś.
 old.man-ERG **boy-ERG** girl-ABS 3SG-3SG-3SG-CAU-carry-PRET-AFF
 'The old man made the boy carry the girl.' (Matasovic 2010:50)

(38) *Ergative-marked Causee in Macushi productive causatives*

imakiupi kupi **jesus-ya** emaputi yonpa-pi makiu-ya teuren.
 bad do **Jesus-ERG** CAU try-PST Satan-ERG frust
 'Satan unsuccessfully tried to make Jesus do bad.' (Abbott 1991:40)

Given the data in (36)-(38), we expect to see the same pattern in Philippine-type Austronesian languages, whereby the *Causee* in both AV- and CV-causatives is predicted to be accessible to X-marking—if X marks inherent ergative Case. This hypothesis is illustrated in (39):

(39) *Predicted argument-marking pattern in causatives under an ergative analysis of X*

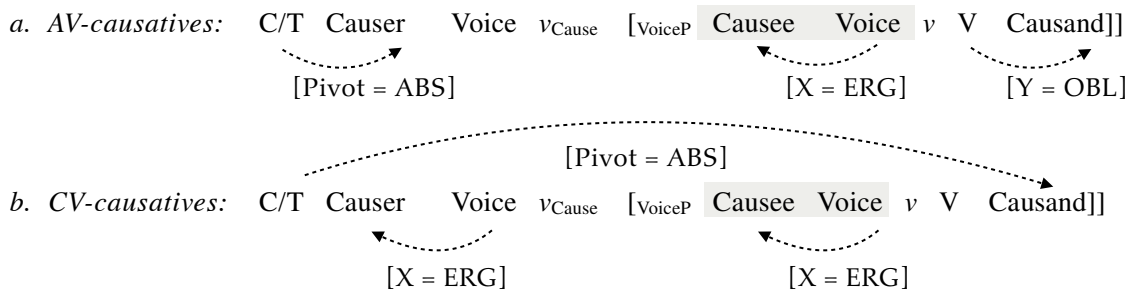

As (39) indicates, if X realizes ergative Case, it is predicted that it will be available to the embedded external argument. Therefore, in both AV-causatives (39a) and CV-causatives (39b), the Causee is expected to be accessible to X-marking.

Contra the prediction in (39), novel data from Puyuma, Amis, Seediq, and Tagalog suggests that X-marking is unavailable to the Causee in either AV- or CV-causatives. This is seen in (40)-(41):

(40) *Unavailability of X-marking to the Causee in AV-causatives*

- a. (***tu**=)Ø-pa-kalat=ku kana suwan kan senten. [Puyuma]
 (***3.X**=)AV-CAU-bite=1SG.PIVOT SG.X dog SG.PIVOT Senten
 'I made the dog bite Senten.'
- b. Ø-pa-pi-kalat kaku **tu/*nu** wacu ci-afan-an. [Amis]
 AV-CAU-PI-bite 1SG.PIVOT **Y/*X** dog PN-Afan-Y
 'I made the dog bite Afan.'
- c. Ø-p-tinun=ku **Ø/*na** robo Ø lukus. [Seediq]
 AV-CAU-weave=1SG.PIVOT **Y/*X** Robo Y clothes
 'I asked Robo to sew the clothes.'
- d. **nag**-pa-nakaw=ako **kay/*ni** juan ng kotse. [Tagalog]
 AV.PRF-CAU-steal=1SG.PIVOT **Y/*X** Juan DF.Y car
 'I asked Juan to steal the car.'

(41) *Unavailability of X-marking to the Causee in CV-causatives*

- a. (***tu**=)ku=pa-saletra'-**anay** kan sawagu i senten. [Puyuma]
 (***3.X**=)1SG.X=CAU-slap-CV SG.Y Sawagu SG.PIVOT Senten
 'I asked Sawagu to slap Senten.'
- b. **sa**-pa-pi-nengneng aku **tu/*nu** wawa k-una pusi. [Amis]
 CV-CAU-PI-see 1SG.X **Y/*X** child PIVOT-that cat
 'I asked the child to look at the cat.'
- c. **s**-p-tinun=mu **Ø/*na** robo ka lukus. [Seediq]
 CV-CAU-weave=1SG.X **Y/*X** Robo PIVOT clothes
 'I asked Robo to sew the clothes.'
- d. **i**-p<in>a-nakaw=ko **kay/*ni juan** ang kotse. [Tagalog]
 CV-CAU<PRF>-steal=1SG.X **Y/*X Juan** PIVOT car
 'I asked Juan to steal the car.'

3.4.3 X marks structural nominative Case

As shown above, the distribution of X-marking in productive causatives is restricted to the Causer. Although the Causee is licensed as an external argument, X can never appear on the Causee. This observation contradicts an inherent ergative Case analysis of X, and follows directly from a

nominative Case analysis, as nominative Case is unique per CP and restricted to the highest Caseless phrase per clause.

To the best of my knowledge, the same argument-marking restriction of X is attested across Philippine-type languages: X-marking is available only to the highest argument within a CP. Given the consistent argument-marking patterns shared between the four target languages and other Philippine-type languages, I argue that the same analysis applies to X-marking in other languages.

3.5 Implications: Against a split ergativity analysis for the Philippine-type voice system

I have concluded based on the observations in 3.3–4 that X shows the hallmarks of structural nominative Case, and is incompatible with an ergative Case analysis. This conclusion is in line with previous claims for Chamorro, Tagalog, and Malagasy, which assume a nominative Case analysis of X but do not provide specific empirical evidence (Chung 1994, 1998; Richards 2000; Rackowski 2002; Pearson 2001, 2005; Rackowski & Richards 2005). This analysis, along with the analysis presented in Chapter 2, suggests that the basic argument markers X and Y in the Philippine-type voice system realize nominative and accusative Case, respectively.

Before concluding, I discuss an important implication of the present analysis for a recent proposal put forward by Aldridge (2014, 2016), Teng (2016), and Kaufman (2017):

(42) Philippine-type languages exhibit split ergativity between AV and non-AV clauses. AV clauses exhibit a nominative-accusative alignment, whereas the three non-AV clause types exhibit an ergative-absolutive alignment, as illustrated in (43):

(43) *TABLE 3.6. The argument-marking pattern under the split ergative analysis*

	a. AV	b. PV	c. LV/CV clauses
External argument	[Pivot = NOM]	[X = ERG]	[X = ERG]
Internal argument	[Y = ACC]	[Pivot = ABS]	[Y = OBL]
Loc./Inst./Ben.	[Y = OBL]	[Y = OBL]	[Pivot = ABS]

As illustrated in (40), under the split ergative analysis, Philippine-type AV clauses exhibit a nominative-accusative system, whereas all three types of non-AV clauses are ergative-aligned, with the argument marker X and Pivot realizing ergative and absolutive Case, respectively.

Given the evidence presented in this chapter that X does not mark ergative Case, the split ergative analysis in (42) is difficult to maintain, as is the alleged ergative-absolutive pattern in non-AV clauses (43b)-(c).

3.6 Conclusion

In this chapter, I have argued that the argument marker X, conventionally analyzed as marking inherent ergative Case assigned by transitive verbs (e.g., Mithun 1994; Aldridge 2004 et seq., Wu 2013; Chang 2011, 2015), is better analyzed as marking structural nominative Case. This analysis, along with the accusative Case analysis of Y presented in Chapter 2, suggests that Philippine-type languages exhibit a nominative-accusative case system.

In Section 3.3, I showed that the distribution of X-marking is not restricted to transitive clauses and is available to the internal argument position. I argue accordingly that X cannot mark inherent ergative Case, which is argued to be licensed in Head-Spec relation and restricted to transitive clauses.

In Section 3.4, I further demonstrated that X-marking is unavailable to embedded external argument positions, where inherent ergative Case is predicted to be available. I conclude accordingly that X shows the hallmarks of structural Case, which is limited to one occurrence per CP and restricted to the highest Caseless phrase per clause. The main claims of the chapter are summarized in (44):

(44) *Conclusions of Chapter 3*

- a. X marks structural nominative Case.
- b. Philippine-type languages cannot be analyzed as exhibiting syntactic ergativity or a split ergative system between AV and non-AV clauses.

Chapter 4

Pivot ≠ Absolutive/nominative

The “Pivot” marker in Philippine-type languages is conventionally analyzed as realizing absolutive/nominative Case. Under this analysis, the Philippine-type “Pivot-only” extraction constraint manifests an “absolutive-only” restriction, whereby these languages exhibit syntactic ergativity. Now, given the conclusion from Chapter 3 that the argument marker X realizes nominative Case, the nature of “Pivot”-marking requires a reexamination.

In this chapter, I demonstrate that a nominative/absolutive Case analysis of “Pivot”-marking is difficult to maintain. Support for this claim comes from novel binding diagnostics on five Philippine-type languages (Puyuma, Amis, Seediq, Tagalog, Subanon). Across these languages, voice alternation and Pivot-selection invariably do not trigger an argument structure alternation (i.e., object shift and/or applicativization), suggesting that the licensing of “Pivot” does not respect the locality condition on nominative Case-licensing. I argue accordingly that a nominative/absolutive Case analysis of “Pivot”-marking is untenable. Given that these five languages represent four different Austronesian primary branches, I argue that “Pivot”-marking in a Philippine-type voice system is best analyzed as independent of Case. In approaching this conclusion, I present evidence against a high applicative analysis of Philippine-type Locative voice (LV) and Circumstantial voice (CV) clauses, and argue that a Pivot in LV/CV clauses (e.g., Locative, Instrument, Benefactor) is an adjunct that adjoins to the verb phrase. If this analysis is on the right track, a Pivot is inappropriately viewed as the subject of a clause, despite its prominence in A'-extraction accessibility.

4.1 Introduction

I have shown in Chapters 2 and 3 that the basic argument markers X and Y in the Philippine-type voice system are best analyzed as nominative and accusative Case, respectively. This conclusion brings us to an important subsequent question: what is the nature of “Pivot”-marking, which falls on the external argument in AV clauses (1a) and the internal argument in PV clauses (1b)?

(1) TABLE 4.1. *The argument-marking alternation between Philippine-type AV and PV clauses*

	a. Actor voice	b. Patient voice
External argument	<i>Pivot</i>	X = Nominative
Internal argument	Y = Accusative	<i>Pivot</i>

Much previous work on Austronesian syntax has maintained that “Pivot” marks absolutive/nominative Case. Along the lines of these analyses, a Pivot phrase is commonly viewed as the *subject* of a clause, given its purported case status and prominence in A'-extraction accessibility. However, if the nominative Case analysis of X presented in Chapter 3 is on the right track, “Pivot” should not mark nominative/absolutive Case.

In this chapter, I demonstrate that the distribution of “Pivot”-marking across Puyuma, Amis, Seediq, and Tagalog is indeed incompatible with a nominative Case analysis. This observation, along with the current analysis of X and Y, reinforces the conclusion from the preceding chapters that Philippine-type languages do not exhibit ergativity.

Support for this claim comes from novel binding data on (i) productive causatives, (ii) ditransitives, and (iii) LV/CV-clauses with a “non-core” Pivot from the four target languages, which reveals that the licensing of “Pivot” is not subject to locality. Given the consistent results obtained from the four different Austronesian primary branches, I argue for the analysis in (2):

(2) *Main claims of this chapter*

- a. The morphological marker “Pivot” is independent of Case.
- b. Voice alternation in a prototypical Philippine-type voice system does not correlate with argument structure alternation. Therefore, Philippine-type voice affixes are inappropriately analyzed as *valency-indicating (transitivity/applicative) morphemes*.
- c. A Pivot-marked “non-core” phrase (e.g., Locative, Benefactor, Instrument) in LV/CV clauses is better analyzed as an adjunct, rather than an applied object.

This chapter is structured as follows. In Section 4.2, I summarize previous approaches to Philippine-type “Pivot”-marking. In Section 4.3, I point out problems with the absolutive/nominative Case analysis of “Pivot”-marking, focusing on issues in the high applicative analysis of Philippine-type LV and CV affixes. In Section 4.4, I present novel binding data on productive causatives (4.4.1), ditransitives (4.4.2), and LV/CV-clauses with a “non-core” Pivot (4.4.3) from Puyuma, Amis, Seediq, and Tagalog. Building on the results of binding diagnostics, I argue against the nominative/absolutive Case analysis of “Pivot”-marking. In Section 4.5, I reconsider the nature of the Philippine-type argument-marking mechanism, and propose that “Pivot”-marking is independent of Case. There, I also briefly discuss data from two other Philippine-type languages, Subanon (Estioca forthcoming) and Malagasy (Pearson 2001, 2005), lending further support to the current analysis. In Section 4.6, I revisit a recent proposal discussed in Chapter 3, that Philippine-type languages exhibit split ergativity between AV and non-AV clauses. Given the new observations about Philippine-type LV/CV clauses, I reinforce my arguments against this proposal. Section 4.7 concludes.

4.2 Previous analyses of Philippine-type “Pivot”-marking

Previous analyses of “Pivot”-marking fall into three families: one that analyzes “Pivot” as the morphological realization of absolutive/nominative Case, another that treats it as a topic marker, and

a third that argues that a Pivot phrase bears the status of both subject (recipient of absolutive/nominative Case) and topic. In this section, I provide a brief overview of these three approaches.

4.2.1 “Pivot” as the realization of absolutive/nominative Case

The notion that a Pivot phrase in Philippine-type languages is the recipient of absolutive/nominative Case is widely adopted in previous theoretical literature (e.g., Payne 1982; De Guzman 1988; Gerdtz 1998; Maclachlan & Nakamura 1993, 1997; Kroeger 1993; Mithun 1994; Paul 1999; Aldridge 2004, 2008, 2011, 2017; Liao 2004). Among these works, Guilfoyle, Hung, & Travis (1992) makes an influential proposal that the Pivot in Malagasy occupies the subject position of a clause, i.e., [Spec TP], and checks nominative Case with T. This proposal is further developed in Aldridge (2004) and subsequent work as a core assumption of the ergative approach to Philippine-type languages. See also Keenan (1976) and Liao (2004) for a similar treatment.

A similar assumption has also been adopted in a number of reference grammars and descriptive works on Formosan and Philippine languages. In these works, a Pivot is commonly glossed as “nominative” or “absolutive” and viewed as the subject of the clause, given its prominence in accessing A'-extraction (see, e.g., Tagalog: Payne 1982; Mckaughan 1973; Gerdtz 1988; Starosta, Pawley, Reid 1982; De Wolf 1988; Malagasy: Keenan 1976; Seediq: Chang 1997; Amis: Wu 2006; Puyuma: Teng 2008; Paiwan: Chang 2006; Wu 2013; Rukai: Zeitoun 2007; Philippine-type languages in general: Ross 2002a; Aldridge 2004, 2008, 2016, 2017; Liao 2004).

In this chapter, I argue against this proposal based on new data from Puyuma, Amis, Seediq, and Tagalog. The main discussion will start in Section 4.3.

4.2.2 “Pivot” as a topic marker

A second family of analyses holds that a Pivot phrase in Philippine-type languages is a topic, rather than a subject (see, e.g., Tagalog: Schachter & Otnes 1972; Schachter 1976, 1977; Carrier-Duncan 1985; Shibatani: 1988; Richards 2000; Foley & Van Valin 1984; Naylor 1995; Katagiri 2006; Cebuano: Shibatani 1988; Malagasy: Pearson 2001, 2005; Atayal: Erlewine to appear).

The notion that Pivot status is associated with topichood is not new. Keenan (1976), for instance, has pointed out that Pivot phrases in Malagasy are consistently associated with more “referential prominence” than subjects in other languages. As he notes, unlike subjects in English, a Pivot in Malagasy obligatorily carries an existential presupposition, and is systematically identified by native speakers as denoting the participant whom the sentence is about. Pearson (2001) makes a similar observation, reporting that Pivot phrases in Malagasy function as topics in the topic-comment structure of the clause.

A similar proposal has also been made for Tagalog. In line with Schachter & Otnes's (1972) account of Tagalog Pivots, Richards (2000) and Rackowski (2002) have explicitly argued that Pivots in Tagalog occupy an A'-position, parallel to topics in Icelandic and German.

A similar analysis has also been proposed in Erlewine (to appear), which argues for an A'-topic analysis of Pivots in Atayal, drawing on a language-particular A'-phenomenon. A more detailed review of this line of analyses will be presented in Chapter 5.

4.2.3 The Pivot as bearing both subject and topic status

Other than the two families of analyses introduced above, a recent work by Erlewine, Levin, & van Urk (2017) (henceforth ELV) has proposed that a Pivot in the Philippine-type voice system bears both the status of subject and topic. Under this proposal, Philippine-type languages lack Feature Inheritance (Richards 2007; Chomsky 2008; Miyagawa 2010), whereby both the ϕ -feature and the A'-features (e.g., [uRel], [uTop]) are hosted on C. Therefore, [Spec CP] in these languages is simultaneously an A'- and A-position, similar to that proposed for the Nilotic language Dinka (van Urk 2015). Under ELV's analysis, then, a Pivot in Philippine-type languages is simultaneously both an A- (subject) and A'-element. A more detailed discussion of this proposal will be presented in Chapter 5.

In what follows, I evaluate the absolutive/nominative Case analysis of "Pivot"-marking with novel comparative data from Puyuma, Amis, Seediq, and Tagalog, and show that this approach faces a number of theoretical and empirical issues.

4.3 Issues in the absolutive/nominative Case analysis of Philippine-type "Pivot"-marking

In this section, I introduce the core assumptions of the absolutive/nominative Case analysis of "Pivot"-marking (4.3.1), and outline problems with this analysis (4.3.2).

4.3.1 The absolutive/nominative Case analysis of "Pivot"-marking

A major problem with the absolutive/nominative Case analysis of "Pivot"-marking lies in the high applicative analysis of LV/CV clauses. Before discussing issues with this analysis, I will first revisit the argument-marking pattern in Philippine-type LV/CV clauses, and summarize how it has been analyzed under the absolutive/nominative Case analysis of "Pivot"-marking.

As introduced in Chapter 1, Philippine-type languages exhibit a four-way alternation in argument-marking that correlates with the voice-marking alternation (3):

(3) *Voice alternation in Philippine-type languages (exemplified with Seediq data)*

- a. s<m>ebuc Ø ricah ka heya. [AV]
 <AV>hit Y plum PIVOT 3SG
 'He/she knocked down plums (from the trees).'

- b. sebec-**un**=na **ka ricah.** [PV]
hit-PV=3SG.X **PIVOT plum**
‘He/she will knock down *plums* (from the trees).’
- c. sebec-**an**=na Ø **ricah ka ricah neepah na watan.** [LV]
hit-LV=3SG.X Y plum **PIVOT plum field** **POSS Watan**
‘He/she knocked down plums (from the trees) *in Watan’s plum field.*’
- d. **s**-sebec=na Ø **ricah ka qreti.** [CV]
CV-hit=3SG.X Y plum **PIVOT stick**
‘He/she knocked down plums (from the trees) *with a stick.*’

This voice-conditioned argument-marking alternation represents a shared pattern among Philippine-type languages, summarized in (4). Parentheses in the table indicate that the presence of the phrase is optional.

(4) TABLE 4.2. Shared argument-marking pattern across Philippine-type languages¹

	(a) AV	(b) PV	(c) LV	(d) CV
External argument	<i>Pivot</i>	X	X	X
Internal argument	(Y)	<i>Pivot</i>	(Y)	(Y)
Location	(Loc)	(Loc)	<i>Pivot</i>	(Loc)
Instrument/benefactor	(Y)	(Y)	(Y)	<i>Pivot</i>

As seen in (4), with the appropriate voice morphology, “Pivot”-marking can appear on phrases ranging from core arguments, i.e., Theme in (4b), to what are typically non-core obliques, i.e., Location in (4c) and Instrument in (4d). A fundamental question in examining the validity of the previous accounts of this pattern thus boils down to the mechanism that allows the purported absolutive/nominative Case to fall on seemingly “non-core” phrases in LV/CV clauses.

Under the conventional analysis, these apparent oblique phrases can access “Pivot”-marking (“absolutive case”) because they are assumed to be licensed as a *core object* in LV/CV clauses. This proposal has led to a well-received assumption in (5) (Mithun 1994; Aldridge 2004; Liao 2004; S. Huang 2005; Rackowski & Richards 2005):

- (5) Philippine-type languages exhibit *argument structure alternation* among PV, LV, and CV clauses. In LV/CV clauses, what are typically obliques are licensed as arguments (DPs).

¹ This table does not reflect language-specific innovations. This includes the loss of certain voice distinctions (e.g., Kavalan, Subanon, Malagasy) and that of certain functions in individual voices (e.g., in Amis, a CV affix cannot select a benefactive as the Pivot).

In what follows, I will introduce how this assumption has been articulated under the framework of the Minimalist Program.

4.3.2 The Minimalist approach to the absolutive/nominative Case analysis of “Pivot”-marking

As discussed in Chapter 3, the standard assumption under the Minimalist Program is that structural absolutive/nominative Case is assigned to the highest Caseless argument in a clause. Therefore, an absolutive/nominative Case analysis of “Pivot”-marking entails the assumption in (6):

- (6) A Pivot phrase must be a DP, and it must occupy the highest Caseless position in a clause.

Under (6), the fact that an apparent oblique phrase in Philippine-type LV/CV clauses (e.g., (7)-(8)) can bear “Pivot”-marking has motivated the analysis in (9) (Aldridge 2004, 2008, 2011, 2016, 2017; H. Chang 2011, 2013, 2015):

(7) *The argument-marking pattern in LV clauses*

- a. ku=pubini’-ay² dra dawa **na** **uma**. [Puyuma]
 1SG.X=sow-LV ID.Y millet **PIVOT** **field**
 ‘I sowed millet *in the field*.’
- b. pi-alup-an³ ni ofad **k-una** **lutuk** tu fafuy. [Amis]
 PI-cook-LV X Ofad **PIVOT-that** **mountain** Y boar
 ‘Ofad hunted boars *in that mountain*.’
- c. wada=mu hanguc-an Ø wawa **ka** **pprayan**. [Seediq]
 PRF=1SG.X cook-LV Y meat **pivot** **kitchen**
 ‘I cooked meat *in the kitchen*.’
- d. ni-lutu-an ni ivan ng isda **ang kawali**. [Tagalog]
 PRF-cook-LV X Ivan DF.Y fish **PIVOT** **sauce.pan**
 ‘Ivan cooked fish *in the sauce pan*.’

(8) *The argument-marking pattern in CV clauses*

- a. ku=pangasip-anay⁴ dra kuraw **na** **urtati/walak**. [Puyuma]

² The LV affix *-ay* in Puyuma is a reflex of the Proto-Austronesian optative/hortative LV affix **-ay*, rather than of the indicative LV affix **-an*. The diachronic derivation of this change can be found in Chapter 6.

³ In Amis, the LV and CV affixes are obligatorily accompanied by a valency-indicating prefix *ka-/pi-*. When combining with 1-place verbs, an LV or CV affix appears with the prefix *ka-*, in the form of *ka- ...-an* (8a) and *sa-ka-* (7a). When combining with 2-place verbs, they appear with the prefix *pi-*, in the form of *pi-...-an* and *sa-pi-*. See Wu (2006) for details.

⁴ The CV affix *-anay* in Puyuma is a reflex of the Proto-Austronesian optative/hortative CV affix **-anay*, rather than of the indicative CV affix **Si-/Sa-*. The diachronic derivation of this change can be found in Chapter 6.

1SG.X=fish-CV ID.Y fish PIVOT earthworm/child
 ‘I fished fish *with earthworms/for the child.*’

b. sa-pi-alup ni mama tu fafuy **k-una iduc.** [Amis]
 CV-TR-hunt X father Y boar PIVOT-that spear
 ‘Father hunted boars *with that spear.*’

c. wada=mu s-hanguc Ø wawa **ka libo/robo.** [Seediq]
 PRF=1SG.X CV-cook Y meat PIVOT pot/Robo
 ‘I cooked meat *with the pot/for Robo.*’

d. i-p<in>ang-luto ni ivan ng karne **ang palayok/babae.** [Tagalog]
 CV-<PRF>-PANG-cook X Ivan ID.Y meat PIVOT pot/woman
 ‘Ivan cooked the meat *with a pot/for the woman.*’

(9) Philippine-type LV/CV clauses are *applicative constructions* that encode an oblique as a core object. This object has higher accessibility to A'-extraction than the direct object.

This assumption has been framed as the analysis in (10):

(10) The Philippine-type LV/CV affix is the reflex of a high applicative head, which licenses a specific “non-core” phrase as an applied object (Aldridge 2004, 2008, 2011, 2017)

Under this analysis, the Pivot in LV/CV clauses is base-generated at [Spec High ApplicativeP], which c-commands the internal argument. This is illustrated in (11a)-(b):

(11) *The high applicative analysis of LV/CV clauses under the ergative analysis*

a. *LV clauses*

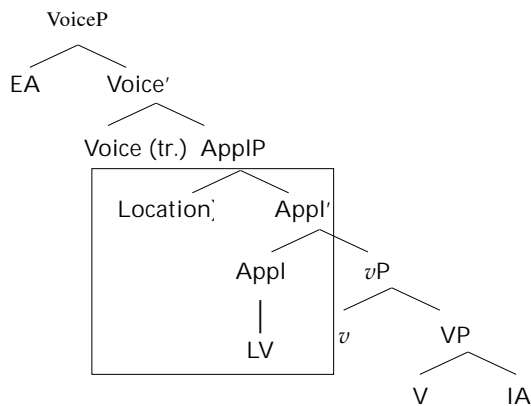

b. *CV clauses*

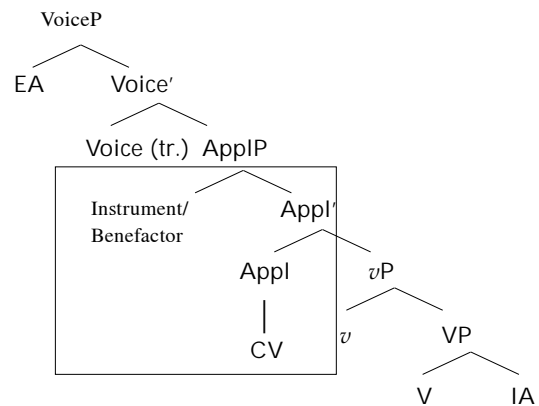

Under (11), the Case-licensing mechanism in LV/CV clauses is as follows: First, the external argument receives inherent ergative Case from transitive Voice⁰, realized as X-marking.⁵ The applied object, which is structurally higher than the internal argument, is then attracted by the EPP feature on transitive Voice⁰ and raises to the outer specifier of VoiceP. There, it enters into agreement with the ϕ -feature and checks absolutive/nominative Case, morphologically realized as “Pivot”-marking.⁶ This is illustrated in (12a)-(b):⁷

(12) Proposed Case-licensing mechanism in LV/CV clauses under the ergative analysis

a. LV clauses

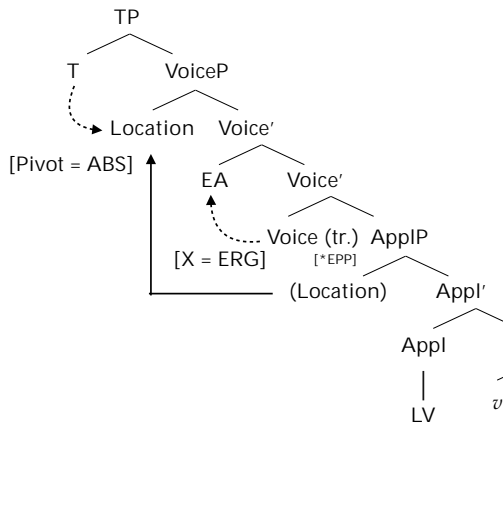

b. CV clauses

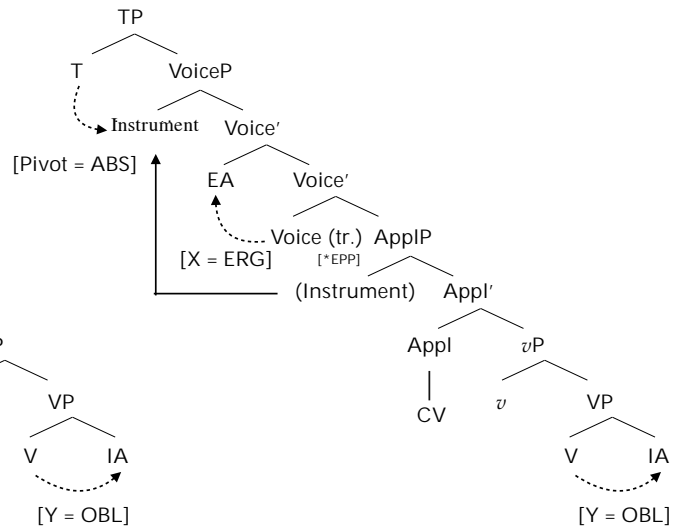

Under this analysis, Philippine-type voice affixes are *valency-rearranging (transitivity/applicative) morphemes* that promote different phrases to subject status. This analysis is illustrated with the Seediq data (13):

⁵ Note that this analysis has been shown to be untenable in Chapter 3.

⁶ This summary follows Aldridge’s (2017) analysis, which assumes that absolutive/nominative Case-checking is an outcome of ϕ -agreement.

⁷ In brief, under this analysis, “Pivot”-marking (absolutive case) is available to a “non-core” phrase in LV/CV clauses under the assumptions that (i) the external argument is inherently Case-licensed with inherent ergative Case, and (ii) the “non-core” phrase is base-generated as a DP higher than the internal argument. This proposed Case-licensing mechanism is illustrated in (a)-(c):

- a. In AV clauses: External argument > Internal argument > Adjunct_{Loc/Inst/Ben}
! [ABS]
- b. In PV clauses: ~~External argument~~ > Internal argument > (Adjunct_{Loc/Inst/Ben})
licensed with [ERG] ! [ABS]
- c. In LV/CV clauses: ~~External argument~~ > Applied object_{Loc/Inst/Ben} > (Internal argument)
licensed with [ERG] ! [ABS]

(14) Table 4.3. Possible candidates for Pivot phrases in LV/CV clauses

a. LV	Location (Source & Goal), Temporal expression, Event, Degree
b. CV	Instrument, Benefactor, Theme of the caused event (in productive causatives), Theme (in ditransitives), Reason, Cause, Manner, Result, Purpose, Stimulus

For instance, in many Philippine-type Formosan languages, an LV affix may select a temporal phrase as the Pivot (15a)-(b):⁸

(15) LV clauses with a temporal phrase as the Pivot

- a. h<n>uqil-**an** na walis **ka** **kusun.** [Seediq]
 die<PRF>-LV X Walis **PIVOT** **yesterday**
 ‘Walis passed away *yesterday*.’
- b. ka-hufut-**an** ni kulas **ku** **inacila.** [Amis]
 KA-born-LV X Kulas **PIVOT** **yesterday**
 ‘Kulas was born *yesterday*.’

A Philippine-type CV affix can also select a Manner phrase as the Pivot, as in (16a)-(b):

(16) CV clauses with a manner phrase as the Pivot⁹

- a. **fangcal** ku **sa-ka-rumadiw** ni lisin. [Amis]
good PIVOT CV-INTR-sing SG.X Lisin
 ‘The way Lisin sang was good.’
- b. **inaba** na(n) tu=**i**-sa-senay. [Puyuma]
good PIVOT 3.X=CV-CA.RED-sing
 ‘The way he/she sang was good.’

To maintain the absolute Case analysis of “Pivot”-marking, the temporal and manner phrases in (15)-(16) are necessarily analyzed as applied objects. However, to the best of my knowledge, such phrases are crosslinguistically unknown to allow applicativization.

II. The unexpected absence of a transitivity-marker co-occurring with the LV/CV affix

Second, according to the analysis summarized in 4.3.2, Philippine-type LV/CV affixes are valency-increasing morphemes (applicative affixes) that appear in clauses that host a transitive Voice (see

⁸ A Seediq speaker I consulted commented that in his perception the Locative voice affix *-an* is associated with space and time.

⁹ Proto-Austronesian CV affix *Si-/Sa- > Amis *sa-*, Puyuma *i-*.

(12)). This predicts that an LV or CV affix should co-occur with the alleged basic transitivity marker, i.e., a PV affix.

However, across Philippine-type languages, both LV/CV clauses disallow a co-occurring PV affix. This is exemplified with the Seediq data (17):

(17) *The unacceptability of the co-occurrence of a PV affix and LV/CV affix*

- a. *wada=mu hanguc-**en-an** Ø wawa ka pprayan. [LV]
 PRF=1SG.X cook-**PV-LV** Y meat PIVOT kitchen
 (intended: 'I cooked meat *in the kitchen*.)
- b. *wada=mu **s-hanguc-en** Ø wawa ka ribo. [CV]
 PRF=1SG.X **CV-cook-PV** Y meat PIVOT pot
 (Intended: 'I cooked meat *with the pot*.)

Importantly, this restriction can be traced back to Proto-Austronesian (Wolff 1973; Starosta, Pawley, & Reid 1982; Ross 2009, 2012). As seen in (18), under the consensus reconstruction, each of the four voice affixes appears as a single morpheme. In other word, an LV/ CV clause cannot host a PV affix.

(18) *Proto-Austronesian indicative voice morphology*

- a. Actor voice *<um>
 b. Patient voice *-en
 c. Locative voice *-an
 d. Circumstantial voice *Si-/Sa-

For the supporters of the ergative analysis, then, Philippine-type Austronesian languages are necessarily assumed to impose a special constraint that requires their transitivity marking to be null

(19) *Pivot placement in CV-marked causatives*

- a. ku=pa-karatr-**anay** kanku=suwan **i** **sawagu**. [Puyuma]
 1SG.X=CAU-chase-CV 1SG.POSS.Y=dog SG.PIVOT **Sawagu**
 ‘I made my dog bite *Sawagu*.’
- b. s-p-seeliq=mu Ø robo **ka** **rodux** **nii**. [Seediq]
 CV-CAU-butcher=1SG.X Y Robo **PIVOT chicken** **this**
 ‘I asked Robo to butcher *this chicken*.’
- c. i-p<in>a-luto=ko kay viktoria **ang** **isda**. [Tagalog]
 CV-CAU<PRF>buy=1SG.X PN.Y Victoria **PIVOT fish**
 ‘I asked Victoria to cook *fish*.’

To maintain the absolutive Case analysis of “Pivot”-marking, then, the Pivot-marked Causand in (19) is necessarily analyzed an applied object base-generated higher than the Causee. However, setting aside the fact that there has been no existing proposal that analyzes a Causand as an applied object in productive causatives, such a treatment is theoretically infelicitous, as it implies that 2-place verbs such as ‘bite’, ‘butcher’, and ‘buy’ (19a)-(c) do not select an internal argument when they combine with a CV affix.

IV. *Lack of functional distinction between the LV and CV affixes*

Fourth, under the absolutive Case analysis of “Pivot”-marking, the LV or CV affixes have been assumed to lack a functional distinction, as both are analyzed as the reflex of a high applicative head (Aldridge 2004, 2011, 2016, 2017). This raises the question of why the same functional head is realized in two distinct morphological forms.¹¹

V. *Issues in accounting for mood-inflections in LV/CV affix*

Fifth, the high-applicative analysis of the LV/CV affix is difficult to reconcile with an often overlooked fact that both affixes inflect for mood.

As seen below, Proto-Austronesian voice morphology shows a three-way mood inflection with all four voice affixes:

(20) *TABLE 4.4. Prototypical Philippine-type voice morphology*

	Actor voice	Patient voice	Locative voice	Circumstantial voice
a. indicative	*<um>	*-en	*-an	*Si-/Sa-
b. optative, hortative	*-a	*-aw	*-ay	*-anay
c. imperative, negative	*-Ø	*-u	*-i	*-an

¹¹ Rackowski (2002) proposes that an LV affix in Tagalog is the reflex of a low applicative head, and a CV affix is that of a high applicative head. The low applicative analysis of the LV affix was based primarily on its function in LV-ditransitives, wherein a Recipient is marked as the Pivot. However, whether the same low applicative analysis applies to other LV-clauses that contain a Locative or temporal Pivot (see the previous examples (8) and (18)) remains an issue for this analysis.

These mood distinctions are preserved in conservative Philippine-type languages. See the following data from Paiwan (21) and Atayal (22):

(21) *Mood inflection in Paiwan's LV affix*

- a. aku su-vaik-**an** **timadju?** [LV: indicative]
 why 2SG.X=leave-LV.INDF 3SG.PIVOT
 'Why are you leaving *him* there?'
- b. ku=vaik-**ay**=**mun**. [LV: optative]
 1SG.X=leave-LV.OPT=2PL.PIVOT
 'I am going to leave (you).' (lit. 'I shall leave *from you*.')
- c. vecik-**i** **aicu** **a qadupu** ta su=ngadan! [LV: imperative]
 write-CV.IMP PIVOT.this LK paper Y 2SG.POSS=name
 'Write your name *on this paper!*' (A. Chang 2006:188)

(22) *Mood inflection in Atayal's CV affix*

- a. si-tuting=mu cu' ma-bka' cu' buiqa' **ku' tatuting.** [CV: indicative]
 CV.INDF-hit=1SG.X LK AV-broken Y bamboo PIVOT hammer
 'I hit the bamboo broken *with the hammer*.' (Jiang 2016:165; glosses mine)
- b. tuting-**anay**=mu cu' 'ulaqi' **ku' kahuniq.** [CV: optative]
 hit-CV.OPT=1SG.X Y child PIVOT wood
 'I would hit the child *with the stick*.' (Huang 1995; glosses mine)
- c. tuting-**ani ku'** **kahuniq!** [CV: imperative]
 hit-CV.IMP PIVOT wood
 'Hit *with the stick!*' (Huang 1995; glosses mine)

These observations thus force a typologically unusual assumption that applicative morphemes in Philippine-type Austronesian languages inflect for mood.¹² To the best of my knowledge, there has been no parallel case attested in another language.

Given the issues outlined above, the validity of the absolutive/nominative analysis of "Pivot"-marking requires a reexamination.

4.4 Pivot ≠ Absolutive/nominative

In this section, I show that an absolutive/nominative Case analysis of "Pivot"-marking is indeed difficult to maintain. I will first discuss the prediction of this analysis in terms of the distribution of the Pivot in LV/CV clauses in 4.4.1. In 4.4.2–4, I present novel evidence from productive causatives (4.4.2), ditransitives (4.4.3), and LV/CV-clauses with a "non-core" Pivot (4.4.4) against this analysis.

¹² See Chapter 7 for a detailed discussion of the mood inflections in Philippine-type voice morphology.

4.4.1 The predicted distribution of Pivot-marking under the absolutive/nominative Case analysis

I begin by outlining the predictions of the absolutive Case analysis of “Pivot”-marking (4.4.1.1), and providing some background information on how binding works in the four target languages (4.4.1.2).

4.4.1.1 Predictions for the distribution of the Pivot phrase under the absolutive Case analysis

As discussed in 4.3, a core prediction of the absolutive Case analysis of “Pivot”-marking is that a Pivot must occupy the highest Caseless position in a clause to enter into an Agree relation with ϕ -feature and check absolutive Case. Therefore, for this analysis to be tenable, there must be *argument structure alternation* between a PV clause and an LV/CV clause. This is illustrated in (23):

(23) *The expected voice-conditioned argument structure alternation under the absolutive Case analysis of “Pivot”-marking*

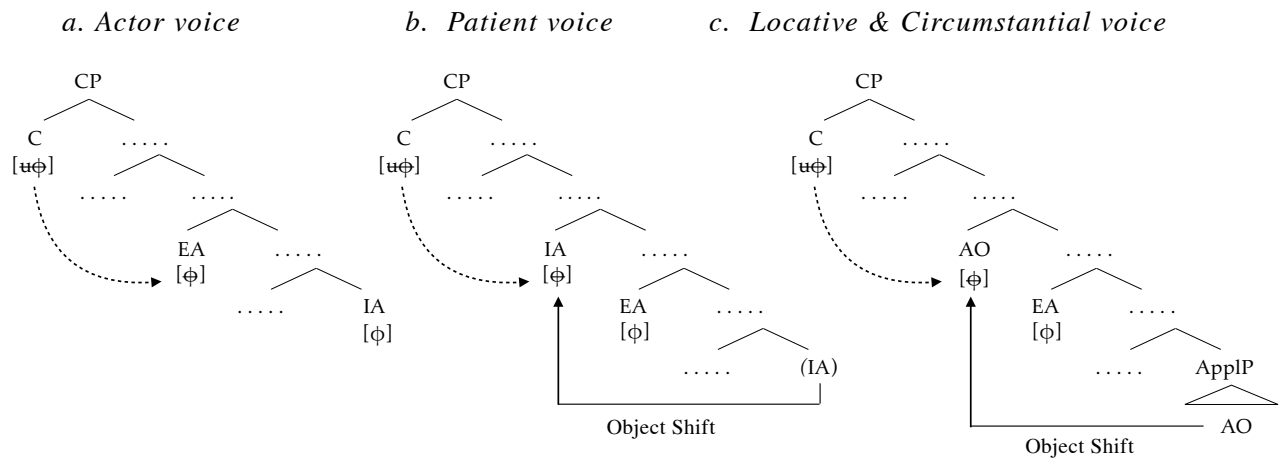

If, however, voice alternation in Philippine-type languages is *not* accompanied by argument structure alternation, illustrated in (24), the absolutive/nominative Case analysis for “Pivot” cannot be maintained, as this scenario indicates that the licensing of “Pivot”-marking does not respect locality:

(24) *Locality violation in “Pivot”-licensing under the scenario where voice alternation triggers no argument structure alternation*

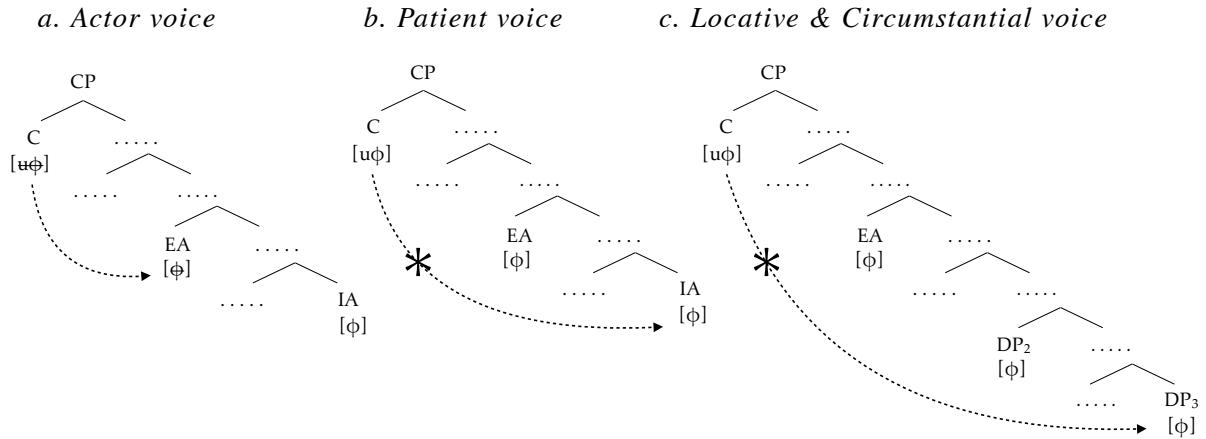

In this section, I will demonstrate that voice alternation in productive causatives, ditransitives, and 3-place LV/CV clauses invariably fails to trigger an argument structure alternation (i.e., applicativization).

4.4.1.2 *The distribution of “Pivot”-marked phrase under the absolutive Case analysis*

I will first clarify my assumptions of binding and present background information of how binding works in the four target languages, Puyuma, Amis, Seediq, and Tagalog.

In examining the structures of the three target constructions, I adopt the standard assumption of c-command and binding in (25):

(25) A binds into B iff A c-commands B, and A and B are coreferential.

According to primary fieldwork, in both Puyuma and Seediq, linear word order has no effect on the binding relations between arguments. In Puyuma, which allows flexible word order among nominals, either a reflexive pronoun or a pronominal variable may precede its antecedent in linear order without affecting the binding judgement. This is seen in (26a)-(b):

(26) *Possible word orders between antecedent and anaphor/variable in Puyuma*

- a. adri Ø-sagar **kanta’aw** i senten. [reflexivization]
 NEG AV-like **3SG.REFL.Y** SG.PIVOT Senten
 ‘Senten dislikes herself.’
- b. p<en>ukepuk **kantu=walak** na taynaynayan driya. [variable binding]
 <AV>hit **3.POSS.Y=child** DF.PIVOT mothers every
 ‘Every mother<i> hit her<j> child.’ (✓ bound variable reading)

morphological marker. A non-Pivot Causer always bears X-marking (i.e., nominative), and a non-Pivot Causee or Causand always bears Y-marking (i.e., accusative).¹⁴

Below I present data from five languages from four different subgroups of Austronesian, Puyuma, Amis, Seediq, Tagalog, and Cebuano, to illustrate this fixed argument-marking pattern.

(29) *Puyuma (Puyuma)*

- a. Ø-pa-trekel=**ku** kana bangsaran kana eraw. [AV]
 AV-CAU-drink=**1SG.PIVOT** DF.Y young.man DF.Y alcohol
 ‘I asked the young man to drink the alcohol.’
- b. ku=pa-trekel-**aw na bangsaran** kana eraw. [PV]
 1SG.X=CAU-grow-PV **DF.PIVOT young.man** DF.Y alcohol
 ‘I asked *the young man* to drink the alcohol.’
- c. ku=pa-trekel-**anay** kana bangsaran **na eraw.** [CV]
 1SG.X=CAU-drink-CV DF.Y young.man **DF.PIVOT alcohol**
 ‘I asked the young man to drink *the alcohol.*’

(30) *Amis (East Formosan)*

- a. Ø-pa-pi-takaw **kaku** t-una wawa t-una paysu. [AV]
 AV-CAU-TR-steal **1SG.PIVOT** Y-that child Y-that money
 ‘I asked that child to steal that money.’
- b. pa-pi-takaw-**en** aku **k-una wawa** t-una paysu [PV]
 CAU-TR-steal-PV 1SG.X **PIVOT-that child** Y-that money
 ‘I asked *that child* to steal that money.’
- c. **sa-pa-pi-takaw** aku t-una wawa **k-una paysu.** [CV]
 CV-CAU-TR-steal 1SG.X Y-that child **PIVOT-that money**
 ‘I asked that child to steal *that money.*’

(31) *Seediq (Atayalic)*

- a. Ø-p-trima=**ku** Ø laqi gaga Ø papak=na. [AV]
 AV-CAU-wash=**1SG.PIVOT** Y child that Y leg=3SG.POSS
 ‘I asked that child to wash his legs.’
- b. p-trima-un=**mu** Ø papak=na **ka laqi gaga.** [PV]
 CAU-wash-PV=1SG.X Y leg=3SG.POSS **PIVOT child that**
 ‘I asked *the child* to wash his legs.’

¹⁴ In some Philippine-type languages, productive causatives can be marked in PV and share the same argument-marking pattern with PV-causatives. This phenomenon is likely to be a product of a common functional merger between Patient voice and Locative voice in many Philippine-type languages, in which LV-marked clauses take the argument structure of PV-clauses. This proposal is evidenced by distinctive use of LV-causatives in Paiwan (Ferrell 1971:3) and Ifugao (SIL 2014:49), whereby LV-causatives mark the location or time of the caused event as the Pivot. More discussion of this diachronic change can be found in Chapter 7.

- c. s-p-trima=mu Ø laqi gaga **ka** **papak=na.** [CV]
 CV-CAU-wash=1SG.X Y child that **PIVOT leg=3SG.POSS**
 ‘I asked that child to wash *his legs*.’

(32) *Tagalog (Central Philippine, Malayo-Polynesian)*

- a. nag-pa-kanta **ako** kay ivan ng kanta. [AV]
 AV-CAU-sing **1SG.PIVOT** PN.Y Ivan ID.Y song
 ‘I asked Ivan to sing a song.’
- b. p<in>a-kanta=ko **si** **ivan** ng kanta. [PV]
 CAU<PV.PRF>-sing=1SG.X **PN.PIVOT Ivan** ID.Y song
 ‘I asked *Ivan* to sing a song.’
- c. i-p<in>a-kanta=ko kay ivan **ang kanta.** [CV]
 CV-CAU<PRF>-sing=1SG.X PN.Y Ivan **PIVOT song**
 ‘I asked Ivan to sing *a song*.’

(33) *Cebuano (Visayan, Central Philippine, Malayo-Polynesian)*

- a. **nag**-pa-basa **si** **juan** kang maria ug libro sa kusina. [AV]
 AV.PRF-CAU-read **PN.PIVOT Juan** PN.Y Maria Y book LOC kitchen
 ‘*Juan* made Maria read a book in the kitchen.’
- b. **gi**-pa-basa ni juan **si** **maria** ug libro sa kusina. [PV]
 PV.PRF-CAU-read PN.X Juan **PN.PIVOT Maria** Y book LOC kitchen
 ‘Juan made *Maria* read a book in the kitchen.’
- c. i-pa-basa ni juan kang maria **ang libro** sa kusina. [CV]
 CV-CAU-read PN.X Juan PN.Y Maria **PIVOT book** LOC kitchen
 ‘Juan made Maria read *a book* in the kitchen.’ (Lin 2010:349; Tanangkingsing 2009:468)

As seen in (29)-(33), across the five languages, “Pivot”-marking invariably falls on the *Causand* when the causative sentence is CV-marked. Given the consistency of this pattern, I consider it to reflect the core grammar of the Philippine-type voice system. In the following, I investigate the structure of CV causatives and explore whether a high applicative analysis of the CV affix is compatible with its structure as evidenced by binding diagnostics.

4.4.2.1 *Binding relations in CV-causatives*

If the absolutive Case analysis of “Pivot”-marking is on the right track, the “Pivot”-marked *Causand* in CV-causatives must be licensed as an applied object. Given the bi-clausal analysis of CV-causatives in Puyuma, Amis, Seediq, and Tagalog presented in Chapter 3, the expected structure of the construction is illustrated in (34). As seen below, the “Pivot”-marked *Causand* is predicted to be base-generated higher than the *Causee*, whereby it may undergo Object Shift to the highest specifier of the matrix VoiceP, where it checks absolutive/nominative Case:

(34) *The structure of CV-causatives under the ergative analysis*

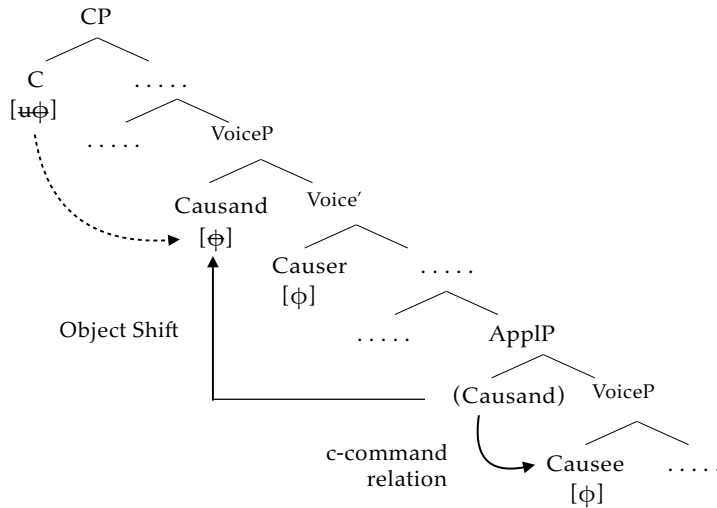

If this proposal is on the right track, we expect the Causee in CV-causatives to be unable to bind into the “Pivot”-marked Causand—since the Causand is hypothesized to be licensed at [Spec High ApplicativeP], which c-commands the Causee.

Contra this prediction, novel comparative data suggests that a Y-marked Causee can bind into a Pivot-marked Causand in CV-causatives in Puyuma, Amis, Seediq, and Tagalog (35a)-(d). This result indicates that the Pivot in CV-causatives is in fact c-commanded by the Y-marked Causee.

(35) *Binding relations in CV-causatives: quantifier-variable binding*

- a. ku=pa-saletra'-**anay** kan sawagu **tayta'aw**. [Puyuma]
 1SG.X=CAU-slap-CV SG.Y Sawagu 3SG.REFL.PIVOT
 'I asked Sawagu to slap himself.' (✓ reflexivization)
- b. sa-pa-pi-nengneng aku ci-afan-an **cingra** *(tu) i dadingu. [Amis]
 CV-CAU-PI-see 1SG.X PN-Afan-Y 3SG.PIVOT *(REFL) LOC mirror
 'I asked Afan to look at herself in the mirror.' (✓ reflexivization)
- c. s-p-tabak=mu Ø heya **ka heya** *(nanaq). [Seediq]
 CV-CAU-slap=1SG.X Y 3SG PIVOT 3SG *(REFL)
 'I asked him/her to slap himself/herself.' (✓ reflexivization)
- d. i-p<in>a-li-linis=ko kay juan **ang kanyang sarili**. [Tagalog]
 CV-CAU<PRF>RED-clean=1SG.X PN.Y Juan PIVOT 3SG REFL
 'I asked Juan to clean himself.'

Importantly, these results are consistent with observations from previous work. Rackowski (2002), for example, has reported that a Causee in Tagalog PV and CV causatives can invariably bind into a Causand. See the following data (36a)-(b):

(38) *The structure of CV-causatives as evidenced by binding diagnostics*

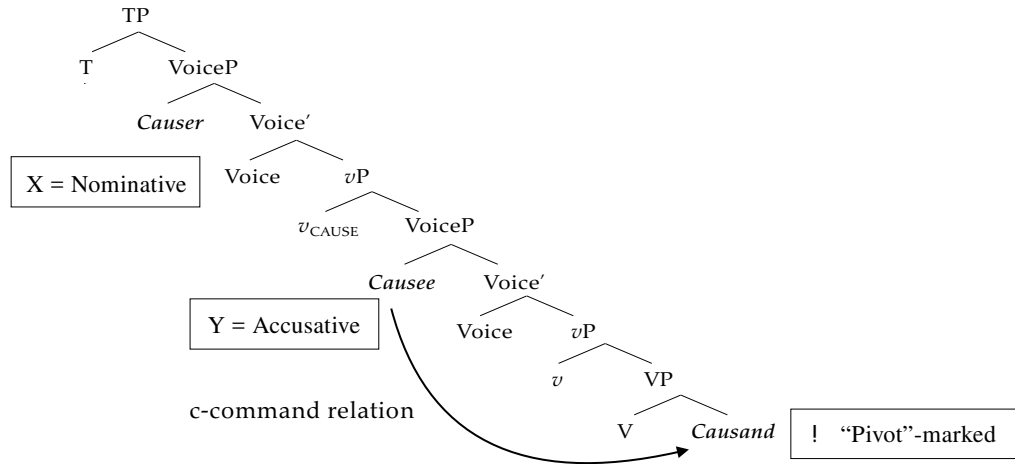

The structure in (38) yields an important implication, that the licensing of “Pivot” does not respect the locality condition on nominative Case-licensing. Especially given that both arguments are not licensed with inherent Case, the fact that “Pivot”-marking can “skip” both the Causer and the Causee and fall on the Causand suggests that its cannot be analyzed as the reflex of structural nominative/absolute Case.

4.4.2.2 *The structure of PV-causatives*

This observation about CV-causatives brings us to a subsequent question: what is the structure of PV-causatives (39b)? Under the absolute/nominative Case of “Pivot”-marking, PV-causatives must employ an argument structure different from that of CV-causatives, whereby the “Pivot”-marked Causee is the highest Caseless argument in the clause:

(39) *TABLE 4.6. The shared argument-marking pattern in productive causatives*

	a. AV	b. PV	c. CV	
Causer	<i>Pivot</i>	X	X	X = Nominative
Causee	Y	<i>Pivot</i>	Y	Y = Accusative
Causand	Y	Y	<i>Pivot</i>	

Binding diagnostics on PV-causatives in the four target languages suggests that the purported argument structure alternation between (39b) and (39c) is unmotivated. As seen in (40)-(43), both the reflexivization and quantifier-variable binding tests suggest that PV-causative share the same binding relations with CV-causatives. In both constructions, the Causee c-commands the Causand, regardless of their argument-marking:

(40) *Binding relations in PV-causatives: reflexivization*

- a. ku=pa-saletra'-aw i sawagu kanta'aw. [Puyuma]
 1SG.X=CAU-slap-PV SG.Y Sawagu 3SG.REFL.Y
 'I asked Sawagu to slap himself.' (✓ reflexivization)
- b. pa-pi-nengneng-en aku ci-afan cingran-an tu i dadingu. [Amis]
 CAU-PI-see-PV 1SG.X PN.PIVOT-Afan 3SG.Y REFL LOC mirror
 'I made Afan look at herself in the mirror.' (✓ reflexivization)
- c. wada=mu p-tabak-un Ø heya nanaq ka heya. [Seediq]
 PRF=1SG.X CAU-slap-PV Y 3SG REFL PIVOT 3SG
 'I made him/her slap himself/herself.' (✓ reflexivization)
- d. p<in>a-pa-ligo=ko si ivan ng sarili niya. [Tagalog]
 CAU<PV.PRF>-RED-bathe=1SG.X PN.PIVOT Ivan Y REFL 3SG
 'I am making Ivan bathe himself.' (✓ reflexivization)

(41) *Binding relations in PV-causatives: quantifier-variable binding*

- a. ku=pa-sabsab-aw na bangsaran driya kantu=paliding. [Puyuma]
 1SG.X=CAU-wash-PV SG.PIVOT young.man every 3.POSS.Y=car
 'I asked every young man<_i> to wash his<_{i/j}> car.' (✓ bound variable reading)
- b. pa-pi-nengneng-en aku ku cimacima a wawa cingran-an tu i dadingu. [Amis]
 CAU-PI-see-PV 1SG.X PIVOT every LK child 3SG-Y REF LOC mirror
 'I will ask every child<_i> to look at himself in the mirror<_{i/j}>.' (✓ reflexivization)
- c. wada=mu p-trima-un Ø бага=daha ka knkingal laqi. [Seediq]
 PRF=1SG.X CAU-wash-PV Y hand=3PL.POSS PIVOT every child
 'I made every child<_i> wash his<_{i/j}> hands.' (✓ bound variable reading)
- d. p<in>a-pag-hugas=ko ang bawat bata ng kanyang kamay. [Tagalog]
 CAU<PV.PRF>-PAG-wash=1SG.X PIVOT every child Y 3PL.POSS hand
 'I made every child<_i> wash his<_{i/j}> hands.' (✓ reflexivization)

The diagnostics below further suggest that the Causee in PV-causatives behaves like a normal external argument, as does that in AV- and CV-causatives (see Chapters 2 and 3). As seen in (42)-(43), PV-causatives across the four languages allow (i) agent-oriented adverbs and (ii) adverbs of frequency to modify the caused event.

(42) *PV-causatives modified by the adverb of frequency 'again'*

- a. ku=pa-base-aw ku=walak masal kana kiping. [Puyuma]
 1SG.X=CAU-wash-PV 1SG.POSS.PIVOT=child again DF.Y clothes
 'I asked my child to wash the clothes again.' (My child did so again)
- b. pa-pi-tangtang-en ni lisin heca ci-sawmah t-una titi. [Amis]
 CAU-PI-cook-PV X Lisin again PN.PIVOT-Sawmah Y-that pork
 'Lisin will ask Sawmah to cook that pork again.' (Sawmah will do so again)
- c. wada=mu p-hanguc-un Ø sari nii dungan ka iwan. [Seediq]

PRF=1SG.X CAU-cook-PV Y taro this **again** PIVOT Iwan
 ‘I asked Iwan to cook this taro again.’ (Iwan did so again)

- d. p<in>a-pag-kanta=ko si maria **ulit** sa kanta. [Tagalog]
 CAU<PRF.PV>-PAG-sing=1SG.X PN.PIVOT Maria **again** DF.Y song
 ‘I asked Maria to sing the song again.’

(43) *PV-causatives with agent-oriented adverbs that modify the caused event*

- a. ku=pa-base-**aw** i sawagu **pakirep** na kiping. [Puyuma]
 1SG.X=CAU-wash-PV SG.PIVOT Sawagu **vigorously** DF.PIVOT clothes
 ‘I asked Sawagu to give the clothes a good washing.’ (lit. ‘wash it vigorously’)
- b. pa-pi-tangtang-**en** ni panay ci-afan t-una futing **pina’un**. [Amis]
 CAU-PI-cook-PV X Panay PN.PIVOT-Afan Y-that fish **carefully**
 ‘Panay will ask Afan to cook that fish carefully.’ (Afan did so carefully)
- c. wada=mu p-sais-**un** Ø lukus **murux** ka robo. [Seediq]
 PRF=1SG.X CAU-sew-PV Y clothes **independently** PIVOT clothes
 ‘I asked Robo to sew the clothes independently.’ (Robo did so independently)
- d. i-p<in>a-luto=ko kay ivan ang babuy **nang maayos**. [Tagalog]
 CV-CAU<PRF>-cook=1SG.X PN.Y Ivan PIVOT pork **CONJ carefully**
 ‘I asked Ivan to cook the pork carefully.’ (Ivan did so carefully)

The data above thus suggests that PV-causatives across the four languages employ a bi-clausal structure, as do AV- and CV-causatives.

4.4.2.3 *The absence of voice-conditioned argument structure alternation in causatives*

The observations above point to a simple analysis of the structure of productive causatives in Puyuma, Amis, Seediq, and Tagalog: a Causee invariably c-commands a Causand, regardless of the voice-marking of the clause and the argument-marking of the two arguments.

Given this generalization, we expect the binding relation between the Causer and the Causee to also be invariable. This prediction is borne out with novel data from the four languages, which suggests an invariable binding relation between the Causer and the Causee regardless of voice type. This is exemplified with Puyuma data in (44):

(44) *Binding relation between the Causer and the Causee: Puyuma*

- a. Ø-pa-dirus [na **taynaynayan driya**] [kantu=walak] [kantu arebu]. [AV]
 AV-CAU-wash [DF.PIVOT **mothers every**] [3.POSS.Y=child] [3.poss.Y hair]
 ‘Every mother_{<i>} asked her_{<i/j>} child_{<k>} to wash his/her_{<i/k>} hair.’ (✓ bound variable reading)
- b. tu_i=pa-dirus-**aw** [kana taynaynayan driya]_i [tu=**walak**] [kantu=arebu]. [PV]
 3.X=CAU-wash-PV [DF.X **mothers every**] [3.POSS.PIVOT=**child**] [3.poss.Y=hair]
 ‘Every mother_{<i>} asked her_{<i/j>} child to wash his/her_{<i/k>} hair.’ (✓ bound variable reading)
- c. tu_i=pa-dirus-**anay** [kana taynaynayan driya]_i [kantu=walak] [tu=**arebu**]. [CV]

3.X=CAU-wash-CV [DF.X mothers every] [3.POSS.Y=child] [3.POSS.PIVOT=hair]
 ‘Every mother_{<i>} asked her_{<j>} child_{<k>} to wash his/her_{<i/k>} hair.’ (√ bound variable reading)

I conclude accordingly that productive causative constructions across the four target languages show the invariable argument structure in (45) unaffected by voice alternations:

(45) *The structure of productive causatives in Puyuma, Amis, Seediq, and Tagalog*

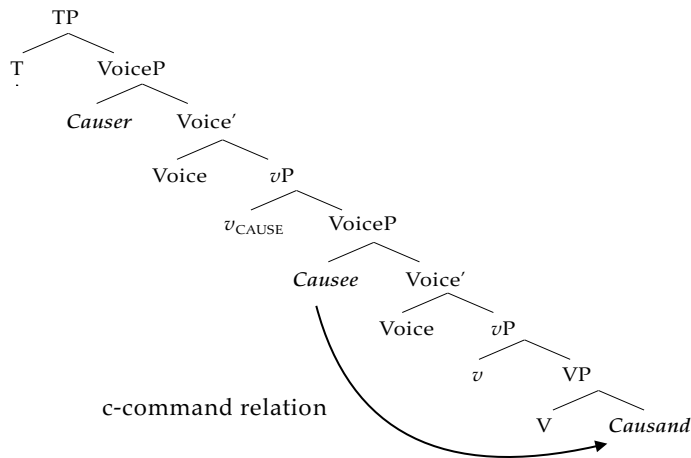

This observation has two important implications: First, the high applicative analysis of the CV affix is in conflict with the binding facts observed in LV/CV clauses. Second, given the conclusion above, the distribution of “Pivot”-marking does not behave like the reflex of structural Case, as this marker is free to fall on an argument that is structurally low when the clause is CV-marked. The main findings of this subsection are summarized in (46):

(46) *Summary of the observations from productive causatives*

- a. Productive causatives in Puyuma, Amis, Seediq, and Tagalog share an invariable binding relation regardless of voice type: *Causer* > *Causee* > *Causand*.
- b. The licensing of “Pivot”-marking in these causative constructions does not obey locality. Therefore, Pivot-marking cannot be analyzed as absolutive/nominative Case.

4.4.3 Ditransitives

I now turn to ditransitive constructions, which provide another ideal testing ground for examining the interaction between voice-marking and the structural relations between arguments. I will demonstrate that the observations from ditransitive constructions are consistent with the conclusions from the analysis of productive causatives, reinforcing the claim that Philippine-type voice alternation is not accompanied by argument structure alternation.

Ditransitive constructions in Philippine-type languages share the argument-marking pattern in (47). According to available descriptions, this pattern is found across languages in seven of the ten Austronesian primary branches: Puyuma (Puyuma), Amis (East Formosan), Kavalan (East Formosan), Seediq (Atayalic), Atayal (Atayalic), Paiwan (Paiwan), Tsou (Tsouic), Saisiyat (Northeast Formosan), Tagalog (Malayo-Polynesian), Bikol (Malayo-Polynesian), Muna (Malayo-Polynesian), Ida’an Begak (Malayo-Polynesian), Yami (Malayo-Polynesian), Ilocano (Malayo-Polynesian), Cebuano (Malayo-Polynesian), and Botolan Sambal (Malayo-Polynesian).¹⁶

(47) TABLE 4.7. *The shared argument-marking pattern in productive causatives*

	a. AV	b. PV/LV	c. CV	
Agent	<i>Pivot</i>	X	X	X = Nominative
Recipient	Y	<i>Pivot</i>	Y	Y = Accusative
Theme	Y	Y	<i>Pivot</i>	

The argument-marking mechanism in (47) can be generalized as follows. First, when a ditransitive is marked in AV, PV/LV, and CV, “Pivot”-marking falls on the *Agent*, *Recipient*, and *Theme*, respectively. Second, when an Agent is non-Pivot-marked, it bears a fixed marking, X (nominative); when a Recipient or a Theme is non-Pivot-marked, it bears a fixed marking, Y (accusative).¹⁷ Below I present data from five Philippine-type languages from different subgroups to illustrate this pattern:

(48) *Puyuma (Puyuma)*

- a. Ø-beray=**ku** kana walak kana tilin. [AV]
 AV-give=**1SG.PIVOT** DF.Y child DF.Y book
 ‘I gave the child the book.’
- b. ku=beray-**ay**¹⁸ **na** **walak** kana tilin. [PV/(LV)]
 1SG.X=give-LV **DF.PIVOT** child DF.Y book
 ‘I gave *the child* the book.’
- c. ku=beray-**anay** kana walak **na** **tilin.** [CV]
 1SG.X=give-CV DF.Y child **DF.PIVOT** **book**
 ‘I gave the child *the book*.’

¹⁶ Sources: Puyuma (primary data, Teng 2008); Amis (primary data); Seediq (primary data; Tsukida 2015; Kuo 2015); Kavalan (Lin, p.c.), Bikol (Mintz 1971:165–188); Tagalog (primary data; Rackowski 2002).

¹⁷ The pattern in (48b) deserves a note. In some Philippine-type languages, some ditransitive verbs cannot combine with a PV affix, and can only be marked in AV, LV, and CV (e.g., Tagalog ‘give’ *bigay*, Puyuma ‘give’ *beray*). In other languages (e.g., Amis, Seediq), a ditransitive verb can be marked in both PV and LV, and both select the Recipient as the Pivot. This phenomenon can be viewed as an outcome of the fact that many of these languages exhibit sporadic lexical gaps between a PV and LV form, which allows an LV-marked verb to take a PV argument structure. For the purpose of this dissertation, I set this phenomenon aside and focus on the argument-marking distinction between the PV/LV pattern (48b) and the CV pattern (48c).

¹⁸ As noted above, in Puyuma, the verb *beray* ‘give’ does not take a PV-form, as opposed to ditransitive verbs in Amis and Seediq (51)-(52), which allow either an PV or LV affix to mark the Recipient as the Pivot.

(49) *Amis (East Formosan)*

- a. Ø-pafeli **kaku** t-una wawa t-una paysu. [AV]
AV-give **1SG.PIVOT** Y-that child Y-that money
'I gave the child that money.'
- b. pafeli-en/-an aku **k-una** wawa t-una paysu. [PV/LV]
give-PV/-LV 1SG.X **PIVOT-that** child Y money
'I gave the child that money.'
- c. sa-pi-pafeli aku t-una wawa **k-una** **paysu** [CV]
CV-PI-give 1SG.X Y-that child **PIVOT-that** money
'I gave the child that money.'

(50) *Seediq (Atayalic)*

- a. wada=ku Ø-paadis Ø dakis Ø tigami. [AV]
prf=**1SG.PIVOT** AV-send Y Dakis Y letter
'I sent Dakis a/the letter.'
- b. wada=mu pdes-un/-an Ø tigami **ka** **dakis.** [PV/LV]
PRF=1SG.X send-PV/-LV Y letter **PIVOT** **Dakis**
'I sent *Dakis* a/the letter.'
- c. wada=mu s-paadis Ø dakis ka tigami. [CV]
PRF=1SG.X CV-send Y Dakis PIVOT letter
'I sent Dakis a/the letter.'

(51) *Tagalog (Central Philippine, Malayo-Polynesian)*¹⁹

- a. nag-bigay **si** **ivan** kay viktoría ng pera. [AV]
AV.PRF-give **PN.PIVOT** **Ivan** PN.Y Victoria ID.Y money
'Ivan gave Victoria money.'
- b. b<in>igay-an ni ivan **si** **viktoría** ng pera. [LV]
<PRF>give-LV PN.X Ivan **PN.PIVOT** **Victoria** ID.Y money
'Ivan gave *Victoria* money.'
- c. i-b<in>igay ni ivan **ang** **pera** kay viktoría. [CV]
CV-<PRF>give PN.X Ivan **DF.PIVOT** **money** PN.Y Victoria
'Ivan gave Victoria the *money*.'

¹⁹ Rackowski (2002) analyzes the Recipient in Tagalog ditransitives as a dative phrase. For instance, she glosses the following *kay*-marked phrases as "dative":

- (a) i-ni-hagis=ko **kay karmen** ang bola.
CV-PRF-throw=1SG.X "DAT" **Carmen** PIVOT ball
'I threw the ball to Carmen.' (Rackowski 2002:29)

However, as introduced in Chapter 1 of this dissertation, *kay* is the Y-form for personal names in Tagalog, as shown in (b). Therefore, there seems to be no obvious reason to analyze the *kay*-marked phrase 'Carmen' in (a) as a dative phrase rather than an object-like phrase:

- (b) p<um>atay/na-nampal si maria **kay** **juan.**
<AV>kill/AV.PRF-slap PN.PIVOT Maria PN.Y **Juan**
'Maria killed/slapped Juan.'

(52) *Botolan Sambal (Central Luzon, Malayo-Polynesian)*

- a. **nang-ipakit hi** **juan** nin litrato kangko. [AV]
 AV.PRF-show PN.PIVOT **Juan** Y picture 1SG.Y
 ‘Juan showed me a picture.’
- b. p<in>akit-**an=ako** ni juan nin litrato. [PV]
 <PRF>show-LV=1SG.PIVOT PN.X Juan Y picture
 ‘Juan showed *me* the picture.’
- c. **i-pakit** ni juan **ya** **litrabo** kangko. [CV]
 CV-show PN.X Juan **PIVOT** **picture** 1SG.Y
 ‘Juan showed me *the picture*.’ (Antworth 1979:41-42)

If the absolutive/nominative Case analysis of “Pivot”-marking is on the right track, the fact that “Pivot”-marking falls on different arguments in PV- and CV-ditransitives entails that there must be an argument structure alternation between the two clause types (i.e., the presence or absence of an applicativizing operation). Furthermore, under the high-applicative analysis of the CV affix, the “Pivot”-marked Theme in CV-causatives is predicted to be licensed as an applied object that is base-generated higher than the Recipient. In what follows, I examine these predictions based on primary data.

4.4.3.1 *Invariable binding relations between PV-ditransitives and CV-ditransitives*

Novel comparative data suggests that ditransitives in Puyuma, Amis, and Seediq show the same binding relations regardless of voice type. Across the four languages (53)-(58), a Recipient can bind into a Theme regardless of voice type, but not vice versa. This suggests that a Recipient always asymmetrically c-commands a Theme regardless of argument-marking and voice alternation:

(53) *Amis: a Recipient always c-commands a Theme regardless of voice*

- a. Ø-paefer **kaku** [ci-ina-an nu cimacima a wawa] [tu wuhung nira]. [AV]
 AV-send 1SG.PIVOT [PN-mother-Y POSS every LK child] [Y book 3PL.POSS]
 ‘I sent every child’s_{<i>} mother his/her_{<i/*j>} book.’ (✓ bound variable reading)
- b. paefer-en aku [**ci-ina** **nu cimacima a wawa**] [tu wuhung nira]. [PV]
 send-PV 1SG.X [PN.PIVOT-mother POSS every LK child] [Y book 3SG.POSS]
 ‘I will send *every child’s mother*_{<i>} his/her_{<i/j>} book.’ (✓ bound variable reading)
- c. sa-paefer aku [ci-ina-an nu cimacima a wawa] [**ku wuhung nira**]. [CV]
 CV-send 1SG.X [PN-mother-Y POSS every LK child] [**PIVOT book 3SG.POSS**]
 ‘I sent every child’s mother_{<i>} *his/her*_{<i/j>} book.’ (✓ bound variable reading)

(54) *Amis: a Theme does not c-command a Recipient regardless of voice*

- a. Ø-pafeli **kaku** [tu wawa nira] [tu paysu nu cimacima a tamdaw]. [AV]
 AV-give 1SG.PIVOT [Y child 3SG.POSS] [Y money POSS every LK person]
 ‘I gave his_{<i>} child every person’s_{<j/*i>} money.’ (“ bound variable reading)

b. **pafeli-en** aku [**ku wawa nira**] [tu paysu nu cimacima a tamdaw]. [PV]
 give-PV 1SG.X [**PIVOT child 3SG.POSS**] [Y money POSS every LK person]
 ‘I will give *his/her*_{<i>} *child* every person’s_{<j/*i>} money.’ (“ bound variable reading)

c. **sa-pafeli** aku [tu wawa nira] [**ku paysu nu cimacima a tamdaw**]. [CV]
 CV-give 1SG.X [Y child 3SG.POSS] [**PIVOT money POSS every LK person**]
 ‘I gave *his/her*_{<i>} *child* *every person*’s_{<j/*i>} *money*.’ (“ bound variable reading)

(55) *Seediq: a Recipient always c-commands a Theme regardless of voice*

a. wada=**ku** Ø-paadis [Ø bubu=na knkingal laqi] [Ø patis=daha]. [AV]
 PRF=**1SG.PIVOT** AV-send [Y mother=3SG.POSS every child][Y book=3PL.POSS]
 ‘I sent every child’s mother_{<i>} *his/her*_{<i/j>} book.’ (✓ bound variable reading)

b. wada=mu pdes=**un** [Ø patis=daha] [**ka bubu=na knkingal laqi**]. [PV]
 PRF=1SG.X send-PV [Y book=3PL.POSS] [**PIVOT mother=3SG.POSS every child**]
 ‘I sent *every child*’s_{<i>} *mother* *his/her*_{<i/j>} book.’ (✓ bound variable reading)

c. wada=mu s-paadis [Ø bubu=na knkingal laqi] [**ka patis=daha**]. [CV]
 PRF=1SG.X CV-send [Y mother=3SG.POSS every child] [**PIVOT book=3PL.POSS**]
 ‘I sent every child’s mother_{<i>} *his/her*_{<i/j>} book.’ (✓ bound variable reading)

(56) *Seediq: a Theme does not c-command a Recipient regardless of voice*

a. wada=**ku** Ø-paadis [Ø bubu=daha] [Ø patis knkingal laqi]. [AV]
 PRF=**1SG.PIVOT** AV-send [Y mother=3PL.POSS] [Y book every child]
 ‘I sent *his/her*_{<i>} mother every person’s_{<j/*i>} book.’ (“ bound variable reading)

b. wada=mu pdes=**un** [Ø patis knkingal laqi] [**ka bubu=daha**]. [PV]
 PRF=1SG.X send-PV [Y book every child] [**PIVOT mother=3PL.POSS**]
 ‘I sent *his/her*_{<i>} *mother* every child’s_{<j/*i>} book.’ (“ bound variable reading)

c. wada=mu s-paadis [Ø bubu=daha] [**ka patis knkingal laqi**]. [CV]
 PRF=1SG.X CV-send [Y mother=3PL.POSS] [**PIVOT book every child**]
 ‘I sent *his/her*_{<i>} mother *every child*’s_{<j/*i>} *book*.’ (? bound variable reading)²⁰

The Puyuma data below deserves a special note. As Puyuma allows flexible word order among nominals, it is possible to avoid linear order as a potential factor for binding interpretation. In (57)-(58), all six ditransitive sentences contain a quantifier phrase that follows the pronominal phrase in linear order. Nevertheless, a bound variable reading invariably obtains when the pronominal is embedded under the Theme phrase (57a)-(c), showing a clear asymmetry with the reverse scenario (58a)-(c). This suggests that Puyuma speakers’ interpretation of binding is not affected by the linear ordering between the quantifier and the pronoun. These ditransitive data thus present a particularly strong case against the hypothesized argument structure alternation between PV- and CV-marked clauses.

²⁰ According to my language consultant, a bound variable interpretation is marginal in this sentence. I propose that this phenomenon is an instance of Weakest Crossover (Lasnik & Stowell 1991), driven by A’-movement of the Pivot-phrase. See Chapter 5 and Appendix III for further discussion.

(57) *Puyuma: a Recipient always c-commands a Theme regardless of voice*

- a. Ø-beray=**ku** [kantu=lribun] [kan tinataw kana kiakarun driya]. [AV]
 AV-give=**1SG.PIVOT** [3.POSS.Y=wages] [SG.Y 3S.POSS.mother LK laborer every]
 ‘I gave every laborer’s_{<i>} mother his_{<i/*j>} wages.’ (✓ bound variable reading)
- b. ku=beray-**ay** [kantu=lribun] [**i tinataw kana kiakarun driya**]. [LV]
 1SG.X=give-LV [3.POSS.Y=wages] [**SG.PIVOT 3S.POSS.mother LK laborer every**]
 ‘I gave *every laborer’s*_{<i>} *mother* his_{<i/*j>} wages.’ (✓ bound variable reading)
- c. ku=beray-**anay [tu=lribun]** [kan tinataw kana kiakarun driya]. [CV]
 1SG.X=give-CV [**3.POSS.PIVOT=wages**] [SG.Y 3S.POSS.mother LK laborer every]
 ‘I gave every laborer’s_{<i>} mother *his*_{<i/*j>} wages.’ (✓ bound variable reading)

(58) *Puyuma: a Theme does not c-command a Recipient regardless of voice*

- a. Ø-beray=ku [kantu=walak] [kantu=lribun kana kiakarun driya]. [AV]
 AV-give=1SG.PIVOT [3.POSS.Y=child] [3.POSS.Y=wages LK laborer every]
 ‘I gave his_{<i>} child every laborer’s_{<j/*i>} wages.’ (“ bound variable reading)
- b. ku=beray-ay [tu=walak] [kantu=lribun kana kiakarun driya]. [LV]
 1SG.X=give-LV [3.POSS.PIVOT=child] [3.POSS.Y=wages LK laborer every]
 ‘I gave *his*_{<i>} *child* every laborer’s_{<j/*i>} wages.’ (“ bound variable reading)
- c. ku=beray-**anay** [kantu=walak] [tu=lribun kana kiakarun driya]. [CV]
 1SG.X=give-CV [3.POSS.Y=child] [3.POSS.PIVOT=wages LK laborer every]
 ‘I gave his_{<i>} child *every laborer’s*_{<j/*i>} wages.’ (“ bound variable reading)

Preliminary data collected from Tagalog points to the same conclusion. As seen below, voice alternation has no effect on the binding relations between the arguments, as evidenced by the invariable binding relation between the Recipient and the Theme in ditransitives:

(59) *Tagalog: a Recipient always c-commands a Theme regardless of voice*

- a. **nag-bigay=ako** [sa nanay ng bawat manggagawa] [ng kanilang sweldo]. [AV]
 AV.PRF-give=**1SG.PIVOT** [DF.Y mother LK every laborer] [ID.Y 3PL.POSS wages]
 ‘I gave every laborer’s_{<i>} mother his_{<i/*j>} wages.’ (✓ bound variable reading)
- b. b<in>igay-**an=ko** [**ang nanay ng bawat manggagawa**] [ng kanilang sweldo]. [PV]
 give<PRF>-LV=1SG.X [**PIVOT mother LK every laborer**] [ID.Y 3PL.POSS wages]
 ‘I gave *every laborer’s*_{<i>} *mother* his_{<i/*j>} wages.’ (✓ bound variable reading)
- c. **i-b<in>igay=ko** [sa nanay ng bawat manggagawa] [**ang kanilang sweldo**]. [CV]
 CV-give<PRF>=1SG.X [DF.Y mother LK every laborer] [**PIVOT 3PL.POSS wages**]
 ‘I gave every laborer’s_{<i>} mother *his*_{<i/*j>} wages.’ (✓ bound variable reading)

4.4.3.2 Invariable binding relations between PV-ditransitives and CV-ditransitives

Given the data presented in 4.4.3.1, we can conclude that ditransitives across different Philippine-type languages invariably employ a Recipient that asymmetrically c-commands the Theme regardless of voice type. Consistent with this observation, the Agent and the Recipient show an invariable binding relation unaffected by voice-marking. This is exemplified with the Amis data (60a)-(c):

(60) *The invariable binding relation between the Agent and the Recipient in ditransitives*

- a. Ø-paefer **ci** **lisin** cingran-an tu tu tikami. [AV]
 AV-send **PN.PIVOT** **Lisin** 3SG.Y REFF Y letter
 ‘Lisin sent herself a/the letter.’ (✓ reflexivization)
- b. paefer-en ni lisin **cingra** **tu** tu tikami. [PV]
 send-PV PN.X Lisin **3SG.PIVOT** **REFL** Y letter
 ‘Lisin sent *herself* a/the letter.’ (✓ reflexivization)
- c. sa-paefer ni lisin cingran-an tu **ku** **tikami**. [CV]
 CV-send PN.X Lisin 3SG-Y REFL **PIVOT** letter
 ‘Lisin sent herself a/the letter.’ (✓ reflexivization)

Following the standard assumption, I consider a double-object construction (DOC) to involve a Recipient that asymmetrically c-commands the Theme, whereas prepositional dative constructions involve a Recipient and a Theme that c-command each other (see, e.g., Bruening 2001, 2010; Pykkänen 2002; Harley 2008). The binding data from the four target languages thus points to a unitary DOC analysis (61):

(61) *The invariable structure of ditransitives across the target languages²¹*

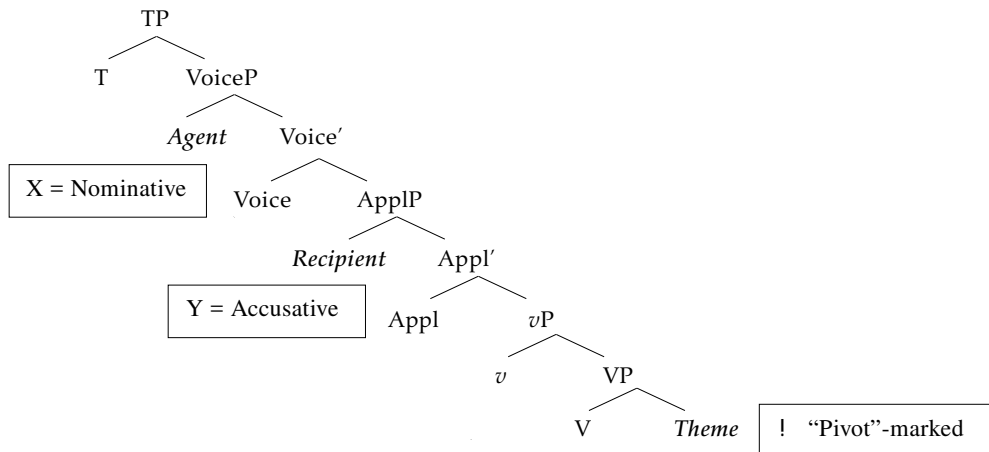

²¹ In (61), I adopt the analysis from Bruening (2001) and Pykkänen (2002) for DOC and assume that the Recipient is introduced by an applicative phrase. Note that this assumption is not in conflict with the current argument against a high applicative analysis for the LV/CV affix, as it is the proposed structure in all three types of voice-marking (with the applicative head assumed to be morphologically null). I remain agnostic with regard to whether the Recipient in (61) receives Case from the applicative head or from the Voice⁰.

This invariable structure indicates that an applicative analysis of the Causand in CV-causatives is difficult to maintain. Furthermore, the fact that “Pivot”-marking can “skip” the Agent and the Recipient and fall on the Theme in CV-ditransitives, as indicated with the case labels in (62), suggests that the licensing of “Pivot”-marking does not respect locality.

The main observations from ditransitives are summarized in (62):

(62) *Summary of this subsection*

- a. Ditransitive constructions in Puyuma, Amis, and Seediq show the following invariable binding relations between arguments regardless of voice-marking: *Agent* > *Recipient* > *Theme*.
- b. The licensing of Pivot-marking does not obey locality. Therefore, Pivot-marking does not mark absolutive/nominative Case.

4.4.4 Simple clauses with a non-core phrase as the Pivot

We have seen in the preceding discussion that productive causatives (4.4.2) and ditransitives (4.4.3) across the four target languages show no voice-conditioned argument structure alternation. I have argued accordingly that the high-applicative analysis for the LV/CV affix is untenable. In this subsection, I present a third piece of evidence for this claim, and argue that a “Pivot”-marked oblique phrase in LV/CV clauses is an adjunct.

4.4.4.1 Claim: LV/CV Pivots are adjuncts

Under the absolutive Case analysis of “Pivot”-marking, a Pivot in LV/CV clauses is claimed to be an applied object that c-commands the internal argument, as in (63a). Now, given the conclusion that the absolutive Case analysis for “Pivot”-marking is difficult to maintain, an applied-object analysis for the Pivot is no longer necessary. This points to the proposal in (63b), whereby a Pivot phrase in LV/CV clauses remains as an adjunct that adjoins to the verb phrase:

(63) *Two different binding scenarios under the competing analyses*

- a. *The high applicative analysis*
- b. *The current analysis*

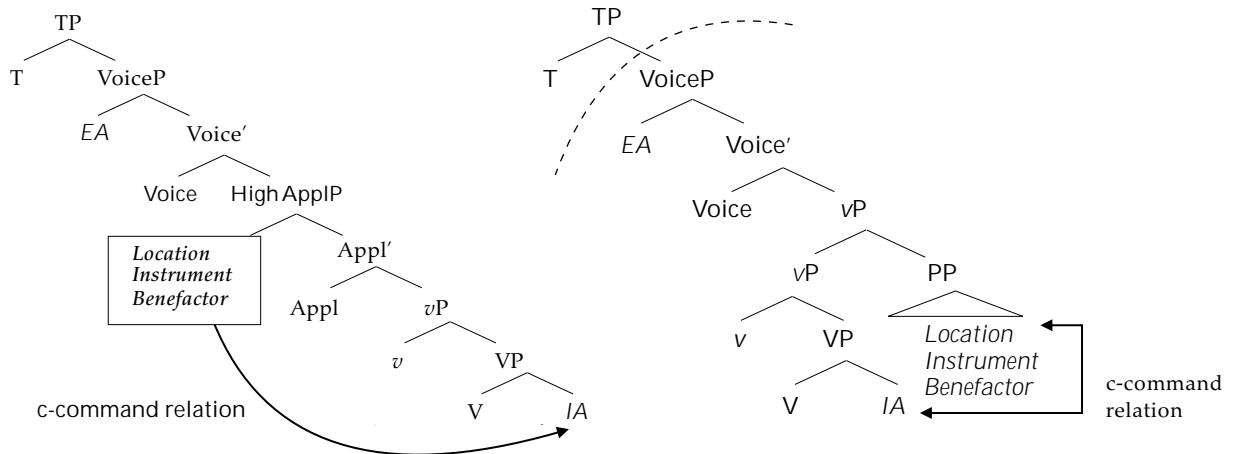

These two analyses make different predictions for the binding relation between the Pivot and the internal argument. If the applicative analysis in (63a) is on the right track, an internal argument in LV/CV clauses should not be able to bind into the Pivot—as it is c-commanded by the alleged applied object. Alternatively, if the structure in (63b) is correct, a quantifier internal argument in LV/CV clauses should be able to bind into the Pivot, as the two phrases are under sisterhood.

Binding diagnostics on LV/CV clauses across Puyuma, Amis, and Seediq point to the structure in (63b). As seen in (64)-(65), a quantifier embedded under the internal argument may bind into a pronominal embedded under a “Pivot”-marked Locative/Instrument/Benefactive phrase in all three languages, suggesting that the structure in (63a) is untenable:

(64) *LV clauses with a Locative Pivot*

- a. ku=retra-ay [tu=etu] [kantu=paysu kana trawtrawtraw driya]. [Puyuma]
 1SG.X=put-LV [3.POSS.PIVOT=desk] [3.poss=money LK persons every]
 ‘I put every person’s_{<i>} money on his_{<j>} desk.’ (✓ bound variable reading)
- b. pi-teli-an aku [tu syasing nu cimacima a wawa] [i cukuwi nangra]. [Amis]
 PI-put-LV 1SG.X [Y picture POSS every LK child] [PIVOT desk 3PL.POSS]
 ‘I put every child’s_{<i>} picture on his_{<j>} desk.’ (✓ bound variable reading)
- c. wada=mu phuma-an [∅ sari na knkingal rodan] [ka neepah=daha]. [Seediq]
 PRF=1SG.X grow-LV [Y taro POSS every old.man] [PIVOT field=3PL.POSS]
 ‘I grew every old man’s_{<i>} taro on his_{<j>} field.’ (✓ bound variable reading)
- b. ni-lutu-an=ko [ng isda ng bawat babae] [ang kanyang kawali]. [Tagalog]
 PRF-cook-LV=1SG.X [ID.Y fish LK woman every] [PIVOT 3PL.POSS pot]
 ‘I cook every woman’s_{<i>} fish in her_{<j>} pot.’ (✓ bound variable reading)

(65) *CV clauses with an Instrument Pivot*

- a. ku=deru-anay [tu=si’uy] [kantu=buir kana taynaynayan driya]. [Puyuma]
 1SG.X=cook-CV [3.POSS.PIVOT=pot] [3.POSS=taro LK mothers every]
 ‘I cooked every mother’s taro with her pot.’ (✓ bound variable reading)
- b. sa-pi-tangtang aku [tu futing nu cimacima a tamdaw] [ku si’uy nangra]. [Amis]
 CV-PI-cook 1SG.X [Y fish POSS every LK person] [PIVOT pot 3PL.POSS]
 ‘I cooked every mother’s fish with her pot.’ (✓ bound variable reading)
- c. s-beebu=mu [∅ knkingal laqi] [ka qreti=daha]. [Seediq]
 CV-hit=1SG.X [Y every child] [PIVOT stick=3PL.POSS]
 ‘I hit every child with his stick.’ (✓ bound variable reading)
- d. i-p<in>ampalo=ko [ang kanyang pamalo] [ng bawat bata]. [Tagalog]
 CV-hit=1SG.X [PIVOT 3SG.POSS hitting.stick] [ID.Y every child]
 ‘I hit every child with his stick.’ (✓ bound variable reading)

The proposal in (64b) is additionally supported by the data below. Under this proposal, the internal argument is under the same maximal projection, i.e., VoiceP, as the “Pivot”-marked adjunct.

Therefore, we expect a quantifier embedded under the adjunct to be able to bind into the internal argument. This prediction is borne out by the data in (66)-(69):

(66) *Binding relation between the Pivot and the internal argument in CV clauses: Puyuma*

- a. ku=tilrili-**anay** [tu=**tratruri**] [kantu=tegami kana maydrang driya].
 1SG.X=write-CV [3.POSS.PIVOT=**pen**] [3.POSS=letter LK old.person every]
 ‘I write every old person’s_{<i>} letter with his/her_{<i/j>} pen.’ (✓ bound variable reading)
- b. ku=tilrili-**anay** [**kantu=tegami**] [kantu=tratruri kana maydrang driya].
 1SG.X=write-CV [3.POSS.Y=**letter**] [3.POSS=pen LK old.person every]
 ‘I write his/her_{<i>} letter with every old person’s_{<i/j>}.’ (✓ bound variable reading)

(67) *Binding relation between the Pivot and the internal argument in LV clauses: Amis*

- a. pi-cukin-**an** aku [tu paysu nu cimacima a wawa] [**ku ticiw nangra**].
 PI-save-LV 1SG.X [Y money POSS every LK child] [**PIVOT passbook 3PL.POSS**]
 ‘I deposited every child’s_{<i>} money into his/her_{<i/j>} passbook.’ (✓ bound variable reading)
- b. pi-cukin-**an** aku [tu paysu nangra] [**ku ticiw nu cimacima a wawa**].
 PI-save-LV 1SG.X [Y money 3PL.POSS] [**PIVOT passbook POSS every LK child**]
 ‘I deposited his/her_{<i>} money into every child’s_{<i/j>} passbook.’ (✓ bound variable reading)

(68) *Binding relation between the Pivot and the internal argument in CV clauses: Seediq*

- a. s-beebu=mu [Ø hulingknkingal laqi] [**ka qreti=daha**].
 CV-hit=1SG.X [Y dog every child] [**PIVOT stick=3PL.POSS**]
 ‘I hit every child’s_{<i>} dog with his/her_{<i/j>} stick.’ (✓ bound variable reading)
- b. s-beebu=mu [Ø huling=daha] [**ka qreti knkingal laqi**].
 CV-hit=1SG.X [Y dog=3PL.POSS] [**PIVOT stick every child**]
 ‘I hit his/her_{<i>} dog with every child’s_{<i/j>} stick.’ (✓ bound variable reading)

(69) *Binding relation between the Pivot and the internal argument in CV clauses: Tagalog*

- a. i-p<in>ampalo=ko [ang kanyang pamalo] [ng aso ng bawat bata].
 CV<PRF>hit=1SG.X [**PIVOT 3SG.POSS hitting.stick**] [ID.Y dog LK every child]
 ‘I hit every child’s_{<i>} dog with his_{<i/j>} stick.’ (✓ bound variable reading)
- b. i-p<in>ampalo=ko [ang pamalo ng bawat bata] [ng kanyang aso].
 CV<PRF>hit=1SG.X [**PIVOT hitting.stick LK every child**] [ID.Y 3SG.POSS dog]
 ‘I hit his/her_{<i>} dog with every child’s_{<i/j>} stick.’ (✓ bound variable reading)

I conclude accordingly that a Pivot in LV/CV clauses is best analyzed as an adjunct that adjoins to the verb phrase.²² Following this analysis, I revisit the LV/CV-marked unaccusative constructions discussed in Chapter 3, and discuss how the argument-marking pattern observed in those constructions follows directly from the current analysis.

4.4.4.2 *The argument-marking pattern in LV/CV-marked unaccusatives revisited*

Recall that in Chapter 3, we discussed the following constructions in Puyuma, Amis, Seediq, and Tagalog (70a)-(b), whereby an unaccusative verb may select a Pivot-marked locative or reason phrase in LV/CV clauses:

(70) *LV/CV-marked unaccusative constructions (exemplified with Seediq data)*

- a. **h-huqil-an** **na riso** *nii ka Paran.* [LV]
 CA.RED-die-LV X **young.man** this PIVOT Paran
 ‘This young man will die in Paran.’
- b. **s-k<n>-narux** **na** **temi** ka knrudan=na. [CV]
 CV-STAT<PRF>sick X **Temi** PIVOT age=3SG.POSS
 ‘Temi got sick because of her age.’

We concluded in Chapter 3 that the marker X on the Theme in (70a)-(b) is best analyzed as structural nominative Case. However, I had set aside the issue that the nominative Case analysis of X is in fact incongruent with a conventional applied-object analysis of the Pivot phrase.

As seen in (71a), under the high applicative analysis of LV/CV clauses, a locative and reason Pivot in (70a)-(b) will intervene between the nominative/absolute Case licenser (C/T) and the X-marked internal argument. This proposed structure thus predicts that X-marking would not be assigned to the internal argument position—wrongly ruling out such sentences. Alternatively, the adjunct analysis of the Pivot in (71b) correctly predicts that the adjunct Pivot is not an intervener for nominative Case-licensing. Therefore, the argument-marking pattern in these constructions can be correctly derived:

²² Drawing on examples (a) and (b), Rackowski & Richards (2005) argue that a Pivot-marked Benefactor in Tagalog CV-clauses is licensed as an applied object at [Spec High ApplP]:

- (a) *b<um>antay=ako* *ng* *bawat anak* [para sa *kayang magulang*].
 <AV>watch=1SG.PIVOT ID.Y every child [P DF.ACC 3SG.POSS parent]
 ‘I watched every child<i> for his<i> parent.’
- (b) **i-b<in>antay=ko* *ng* *bawat anak* *ang* *kayang magulang*.
 CV<PRF>watch=1SG.X ID.Y every child PIVOT 3SG.POSS parent
 (‘I watched every child<i> for his<i> parents.’) (Rackowski & Richards 2005:578)

They also report that changing *i-b<in>antay* to the more acceptable form *i-p<in>ag-bantay* still does not sound natural with a benefactive Pivot. This tentatively suggests that the unacceptability of (a) may be due to multiple factors. I leave this controversy open for future investigation.

(71) *Binding scenario in LV/CV-marked unaccusatives under the competing analyses*

a. *The applicative analysis*

b. *The current analysis*

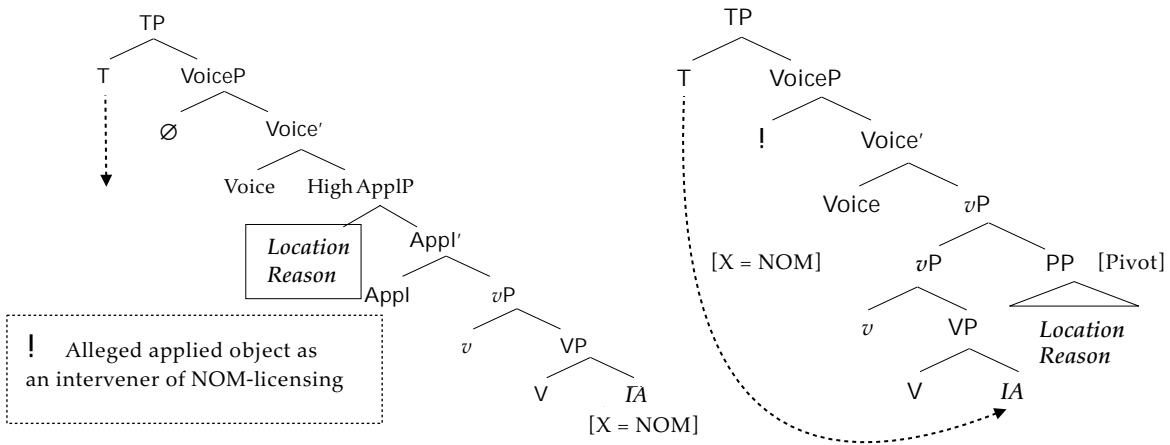

The observations above thus reinforce the adjunct analysis of the Pivot in LV/CV clauses.²³

4.4.5 A note on Malagasy and Subanon

I have argued in the preceding subsections that “Pivot”-marking in Puyuma, Amis, Seediq, and Tagalog does not realize absolutive/nominative Case. In this subsection, I discuss evidence from two other Philippine-type languages, Malagasy and Subanon, that lends further support to this analysis.

4.4.5.1 Malagasy

Pearson (2001, 2005) has reported that in the Philippine-type language Malagasy, a Pivot phrase is obligatorily interpreted in its theta-position, regardless of the voice-marking of the clause. This is seen in the data below in (72a)-(b) (Pearson 2005:424; glosses mine).

(72) *Binding relations in Malagasy AV and PV clauses*

- a. namangy ny rainy **ny mpianatra tsirairay** omaly. [AV]
 PST.AV.visit DET father-3 DET student each yesterday
 ‘Each student_{<i>} visited his_{<i>} father yesterday.’ (✓ bound variable reading)
- b. novangian’ ny mpianatra tsirairay **ny rainy** omaly. [PV]
 PST.PV.visit DET student each DET father-3 yesterday
 ‘His_{<i>} father, each student_{<i>} visited yesterday.’ (✓ bound variable reading)

²³ See footnote 21 for a discussion of why Rackowski & Richards’ applicative analysis (2005) of Tagalog CV clauses might require reconsideration.

As seen above, in Malagasy, a quantifier external argument can bind into the internal argument in both AV and PV clauses. As argued by Pearson (2001, 2005), if promotion-to-Pivot is driven by (nominative/absolute) Case-checking, the internal argument in (72b) should not be able to be bound by the external argument, as promotion-to-subject operations across languages are known to rearrange the binding relations in a clause. This is illustrated with the English examples below. As seen in (73a)-(b), the phrase ‘her child’, which occupies the subject position in (73b), can no longer be interpreted as a variable of the quantifier embedded under the phrase ‘every mother’:

(73) *Promotion-to-subject operation and the binding relation in a clause*

- a. It seems to **every mother**_{<i>} that her_{<i>} child is smart. [non-raising]
 b. Her_{<j/*i>} child seems to **every mother**_{<i>} _____ to be smart. [raising]

The absence of such an effect in the Malagasy data (73b) suggests that promotion-to-Pivot is fundamentally different from [ϕ]-driven A-operations.

The observation from Malagasy thus provides a parallel case in line with the current observations from Puyuma, Amis, Seediq, and Tagalog, that Philippine-type voice alternation does not trigger argument structure alternation. This reinforces our conclusion that a Pivot phrase in these languages is inappropriately analyzed as the recipient of absolute/nominative Case.

4.4.5.2 *Subanon*

Ditransitive constructions in Subanon (Central Philippine, Malayo-Polynesian) provides further support for the current analysis.

According to novel data from Estioca (forthcoming), Subanon has lost the use of the CV affix. To place the Theme in ditransitives as the Pivot, a PV affix is employed. This is seen in the argument-marking pattern (74) observed in Subanon ditransitives:

(74) *TABLE 4.8. The argument-marking pattern in Subanon ditransitives*

	a. AV	b. PV	c. LV
Agent	Pivot	X	X
Recipient	Y	Y	Pivot
Theme	Y	Pivot	Y

Regardless of the functional replacement of the CV affix by the PV affix, ditransitives in Subanon show the same mechanism as other Philippine-type languages—Pivot-selection and voice alternation have no effect on the argument structure of the clause. This is evidenced by the binding data below, which shows that a Recipient always asymmetrically c-commands a Theme in Subanon, regardless of the voice type of the ditransitives (Estioca forthcoming):

(75) *Subanon ditransitives: a Recipient always c-commands a Theme regardless of voice*

- a. **mig-bogoy=u** [nog sweldu nilan] [sog monala-kotow gina'-anan nog gotow]. [AV]
 AV-give=**1SG.PIVOT** [Y wages 3PL.POSS] [Y every-CL mother-PL LK man]
 'I gave every man's_{<i>} mother his_{<i/*j>} wages.' (✓ bound variable reading)
- b. **b<in>ogoy=u** [**og sweldu nilan**] [sog monala-kotow gina'-anan nog gotow]. [PV]
 give<**PRF.PV**>=**1SG.X** [**PIVOT wages 3PL.POSS**] [Y every-CL mother-PL LK man]
 'I gave every man's_{<i>} mother his_{<i/*j>} wages.' (✓ bound variable reading)
- c. **b<in>ogoy-an=ku**²⁴ [nog sweldu nilan] [**og monala-kotow gina'-anan nog gotow**]. [LV]
 give<**PRF**>-**an**=**1SG.X** [Y wages 3PL.POSS] [**PIVOT every-CL mother-PL LK man**]
 'I gave every man's_{<i>} mother his_{<i/*j>} wages.' (✓ bound variable reading)

(76) *Subanon ditransitives: a Theme can never bind into a Recipient regardless of voice*

- a. **mig-bogoy=u** [sog bata' nilan] [nog sweldu nog monala-kotow gotow]. [AV]
 AV-give=**1SG.PIVOT** [Y child 3PL.POSS] [Y wages LK every-CL man]
 'I gave his child_{<i>} every man's_{<i/*j>} wages.' (" bound variable reading)
- b. **b<in>ogoy=u** [sog bata' nilan] [**og sweldu nog monala-kotow gotow**]. [PV]
 give<**PRF.PV**>=**1SG.X** [Y child 3PL.POSS] [**PIVOT wages LK every-CL man**]
 'I gave his child_{<i>} every man's_{<i/*j>} wages.' (" bound variable reading)
- c. **b<in>ogoy-an=ku** [**og bata' nilan**] [nog sweldu nog monala-kotow gotow]. [LV]
 give<**PRF**>-**LV**=**1SG.X** [**PIVOT child 3PL.POSS**] [Y wages LK every-CL man]
 'I gave his child_{<i>} every man's_{<i/*j>} wages.' (" bound variable reading)

The observation from Subanon thus lends additional support against the absolutive/nominative Case of "Pivot"-marking.

4.5 The argument-marking mechanism of the Philippine-type voice system

In this study so far, I have shown that the argument markers X and Y are best analyzed as structural nominative and accusative Case, respectively. I have also shown that "Pivot"-marking across the target languages does not behave like morphological realization of Case. In this section, I reconsider the argument-marking mechanism in the Philippine-type voice system as evidenced by the binding facts in causatives and ditransitives.

Given the observations from causatives and ditransitives, we can conclude that the argument-marking pattern and the structural relations among arguments show a hierarchical mapping:

(77) AV > PV > CV

²⁴ In Subanon, the first person clitic =u changes to its allomorph =ku when attached to a base ending with an alveolar nasal (Estioca p.c).

Namely, when a clause is marked in AV, Pivot-marking falls on the structurally highest argument in a clause (i.e., the nominative), as in (78a). When a clause is marked in PV, Pivot-marking falls on the second highest argument in a clause, i.e., the Recipient in ditransitives or the Causee in causatives, as in (78b). When a clause is marked in CV, Pivot-marking falls on a structurally low argument in a clause, i.e., the Theme in ditransitives or the Causand in causatives, as in (78c):

(78) TABLE 4.9. *The shared argument-marking pattern in ditransitives*

	a. AV	b. PV/LV	c. CV
Agent/Causer	Pivot	Nominative	Nominative
Recipient/Causee	Accusative	Pivot	Accusative
Theme/Causand	Accusative	Accusative	Pivot

Given the pattern in (78), along with the invariable binding relations between arguments across the constructions in (78a)-(c), I propose that the morphological marker “Pivot” is best analyzed as overriding morphological case. The Philippine-type argument-marking mechanism under this analysis is illustrated in (79):

(79) TABLE 4.10. *The argument-marking pattern in ditransitives under the current analysis*

	a. AV	b. PV/LV	c. CV
Agent/Causer	Nominative Pivot	Nominative	Nominative
Recipient/Causee	Accusative	Accusative Pivot	Accusative
Theme/Causand	Accusative	Accusative	Accusative Pivot

A further analysis of the nature of “Pivot”-marking will be presented in Chapter 5.

4.6 Philippine-type voice system ≠ split ergativity between AV and non-AV clauses

Before concluding, I revisit a recent proposal discussed in Chapter 3, that Philippine-type languages exhibit split ergativity between AV and non-AV clauses (Aldridge 2014, 2016; Kaufman 2017; Teng 2016). As introduced in Chapter 3, under this proposal, PV, LV, and CV clauses exhibit an ergative pattern, whereby PV clauses are the basic transitives, and LV/CV clauses are applicative constructions. This proposal is illustrated in (80):

(80) TABLE 4.11. *Argument-marking patterns according to the split-ergative analysis*

	a. AV	b. PV	c. LV/CV clauses
External argument	Pivot = NOM	X = ERG	X = ERG
Internal argument	Y = ACC	Pivot = ABS	Y = OBL
Loc./Inst./Ben.	Y = OBL	Y = OBL	Pivot = ABS

As a high applicative analysis for LV/CV clauses has been shown to be untenable, we can further conclude that the split-ergative proposal is difficult to maintain.

Finally, it is important to note that an ergative analysis of Philippine-type non-AV clauses is theoretically problematic. An ergative pattern is defined by the patterning of subjects of intransitives (S) and the objects of transitives (O). However, under the ergative analysis proposed by Aldridge (2004) and subsequent work, all non-AV clauses are obligatorily analyzed as transitives. This suggests the absence of intransitive subjects (S) in Philippine-type non-AV clauses, thus the absence of a patterning of O with S.

I conclude accordingly that the Philippine-type voice system does not manifest ergativity.

4.7 Conclusion

In this chapter, I have demonstrated that the morphological markers “Pivot” in Philippine-type languages is independent of Case. This conclusion is built on the observation that voice alternation and Pivot-selection across Puyuma, Amis, Seediq, and Tagalog have no effect on the binding relations between arguments, which suggests that the licensing of “Pivot”-marking does not behave like structural nominative/absolutive Case. The main claim of the chapter are summarized in (81)-(82).

(81) *The invariable structure in causatives, ditransitives, and 3-place simple clauses*

- a. Productive causatives: *Causer* > *Causee* > *Causand* (i.e., bi-clausal causatives)
- b. Ditransitives: *Agent* > *Recipient* > *Theme* (i.e., double-object construction)
- c. 3-place simple clauses: *Agent* > *Theme* <> *Location/Instrument/Benefactor*

(82) *Conclusions of the chapter*

- a. Pivot-marking is independent of Case.
- b. The Philippine-type LV and CV affixes are not the reflex of a high applicative head.

This conclusion has important implications. Along with the arguments against a transitivity marking analysis of Philippine-type AV/PV affixes, the evidence against the high applicative analysis of the LV/CV affixes suggests that Philippine-type voice affixes are not *valency-rearranging morphemes* that promote different phrases to subject status. This indicates that Philippine-type “voice” is fundamentally different from voice in Indo-European languages. The nature of these affixes will be further investigated in Chapter 5.

Chapter 5

The nature of the Philippine-type voice system

In this chapter, I argue that Philippine-type Austronesian languages are best analyzed as topic-prominent languages (Li & Thompson 1976) with an accusative case system. I first propose that the morphological marker “Pivot” is a topic marker that overrides morphological case. In other words, when a constituent is marked with a case marker and the topic marker, only the topic marker is morphologically realized. I then provide a novel account for the nature of the four-way division of Philippine-type voice morphology, arguing that the four sets of voice affixes are best analyzed as the morphological reflexes of four different bundles of Agree relations that target the topic (i.e. Pivot) of a clause.

I conclude the chapter with a discussion of how Philippine-type Austronesian languages fit into a syntactic typology of languages. I argue that a Philippine-type voice system is best characterized as hosting a topic (δ)-feature on C and a ϕ -feature on T, with topic-agreement realized as verbal morphology. In this view, Philippine-type languages fit into the definition of *discourse configurational languages* (Kiss 1995; Miyagawa 2010, 2017), which employ overt morphology to spell out the Agree relation with the discourse-configurational feature, [uTop].

5.1 Introduction

I have argued in Chapters 2 and 3 that the basic argument markers X and Y in a Philippine-type voice system realize nominative and accusative Case, respectively. I have also shown in Chapter 4 that the marker “Pivot”, which indicates A'-extraction eligibility of a phrase, is independent of Case. These analyses bring us to the picture in (1), whereby a change in voice morphology correlates with a change in what “Pivot” marks:

(1) TABLE 5.1. *The argument-marking alternation between Philippine-type AV and PV clauses*

	a. Actor voice	b. Patient voice
External argument	Pivot	Nominative
Internal argument	Accusative	Pivot

In this chapter, I investigate three interrelated questions (2a)-(c), concluding my analysis of the Philippine-type voice system.

- (2) a. What is the nature of “Pivot”-marking?
- b. What is the nature of the four-way distinction made by Philippine-type voice morphology?
- c. What is the nature of the Philippine-type voice system?

I argue that “Pivot”-marking is best analyzed as a topic marker, according to which a Pivot phrase is the internal topic of a clause. I then propose that the four-way division of Philippine-type voice affixes morphologically encodes different bundles of Agree relations established with the topic (Pivot) of the clause. Building on these analyses, I argue that Philippine-type languages are topic-prominent languages, as topics play an important role in the morphosyntactic design of these languages.

This chapter is structured as follows. I begin with an investigation of the nature of “Pivot”-marking in Section 5.2, and argue that it is best analyzed as a topic marker. I then propose a new account of the nature of the Philippine-type voice affixes in Section 5.3, showing that they are best characterized as *Subject agreement* (“AV”), *Object agreement* (“PV”), *Locative/temporal agreement* (“LV”), and *Simple topic agreement* (“CV”). In Section 5.4, I present evidence for the agreement analysis of Philippine-type voice morphology. In Section 5.5, I conclude the analyses presented so far in Chapters 2–5.4, and argue that Philippine-type languages show the hallmarks of *discourse-configurational languages* (Li & Thompson 1976; Kiss 1995; Öhl 2010; Miyagawa 2010, 2017).¹

5.2 Claim: “Pivot” is a topic marker

This section has two goals. The first is to show that new data from Puyuma, Amis, Seediq, and Tagalog lends support to the topic analysis of “Pivot”-marking proposed in previous works (e.g., Richards 2000; Rackowski 2002; Pearson 2001, 2005). The second is to demonstrate how the topic analysis of Pivot accounts for the basic argument-marking pattern of Philippine-type languages.

I first lay out my proposal in 5.2.1, and present three independent arguments for this analysis in 5.2.2–4. In 5.2.5, I argue that Pivots are best analyzed as internal topics. In 5.2.6, I put forward the proposal that “Pivot”-marking overrides morphological cases, and demonstrate how this analysis accounts for the Philippine-type argument-marking mechanism discussed in the preceding chapters.

5.2.1 Proposal: “Pivot” marks topic

There are three crosslinguistically common ways to express topics:

- (i) via morphological marking (e.g., Japanese, Korean, Ainu, Burmese),

¹ I address three remaining questions in the chapter-final appendices: (i) the Philippine-type “Pivot-only” constraint in A'-extraction (Appendix I), (ii) the nature of “nominalizer-voice affix homophony” observed in many Philippine-type Austronesian languages (Appendix II), and (iii) the question how the current analysis explains the word order variation among Philippine-type languages (Appendix III).

- (ii) via word order (e.g., by placing topic in the sentence-initial position) (e.g., Chinese, Bantu languages),
- (iii) via intonation or pausing after a topic (e.g., English, Spanish, Russian)

I argue that prototypical Philippine-type languages employ the morphological means (a), whereby “Pivot” is a topic marker that marks both internal topics and hanging (external) topics.²

The notion that Pivot status in Philippine-type languages is associated with topichood is not new. Since Bowen (1965), a number of works have reported that Pivots in Tagalog show topic properties in being obligatorily definite/specific and “old information” (see, e.g., Schachter & Otnes 1972; Shibatani 1988; Richards 2000).

For Malagasy, Keenan (1976) has also noted that the selection of Pivots is consistently associated with “referential prominence”. Pearson (2001, 2005) holds a similar view, reporting that Pivots in Malagasy obligatorily carry an existential presupposition, and are systematically identified by native speakers as denoting the referent whom the sentence is about. For instance, he notes that Malagasy speakers generally judge the following sentences (3a)-(c) as paraphrases of each other. When called upon to explain how the sentences differ, they respond that (5a) *is about the farmer*, (3b) *is about the chicken*, and (3c) *is about the knife* (Pearson 2005:390). As he concludes, these sentences differ in terms of *how they present the event*, specifically with regard to which participant is treated as the topic of the sentence.

(3) *Malagasy*³

- | | | | | | | | | |
|----|---|----------|--------------|--------------|-------|---------|-----------|------|
| a. | namono | ny | akoho | tamin'ny | antsy | ny | mpanboly. | [AV] |
| | PST-AV.kill | DET | chicken | PST-with-DET | knife | DET | farmer | |
| | 'The farmer killed the chicken with the knife.' | | | | | | | |
| | | | | | | | | |
| b. | novonoin'ny | mpamboly | tamin'ny | antsy | ny | akoho. | [PV] | |
| | PST-PV.kill-DET | farmer | PST-with-DET | knife | DET | chicken | | |
| | 'The farmer killed <i>the chicken</i> with the knife' | | | | | | | |
| | | | | | | | | |
| c. | namonoan'ny | mpamboly | ny | akoho | ny | antsy. | [CV] | |
| | PST-CV.kill-DET | farmer | DET | chicken | DET | knife | | |
| | 'The farmer killed the chicken <i>with the knife</i> .' | | | | | | | |

Although Malagasy synchronically lacks morphological marking for the Pivot and the pivotal status of a phrase is indicated solely by word order, Pearson’s report is strikingly similar to native speakers’ judgements of similar sentences in Puyuma, Amis, Seediq, and Tagalog, that the Pivot is

² Here, I use the term ‘prototypical’ in referring to the shared traits of Philippine-type languages that can be identified as prototypical characteristics of the Philippine-type voice system. It excludes language-specific facts such as a Pivot-final word order, which has no sufficient evidence to be a prototypical trait of the voice system, or the independent loss of the morphological marking “Pivot” in innovative languages such as Malagasy. See Appendix III for further details on the word order variation among Philippine-type languages.

³ For the sake of consistency, I change the original glosses “Nominative trigger”, “Accusative trigger”, and “Circumstantial trigger” in Pearson (2001:54) to “AV”, “PV”, and “CV”, respectively.

(5) *The discourse topic as the Theme of a response to a question: Amis*

Q: Discourse topic: Sawmah

na ma-maan ci sawmah?

PST PV-what PN.PIVOT Sawmah

‘What happened to *Sawmah*?’ (context: seeing *Sawmah* crying)

A1: (✓) *The discourse topic is Pivot-marked*

ma-palu ni kulas **cingra**.

PV-hit x Kulas **3SG.PIVOT**

‘Kulas hit *her*.’ [PV]

A2: (✗) *The new information is Pivot-marked*

mi-palu=tu **ci-kulas** cangran-an.

AV-hit=PRF **PN-Kulas.PIVOT** 3SG-Y

(‘*Kulas* hit *her*.’) [AV]

That the unacceptability of A2 is due to the mismatch between Pivot selection and the discourse topic is confirmed by the observation in (6). Here, the discourse topic *Sawmah*, indicated by the question “*What is Sawmah doing?*”, is the Agent in the response “*She is cooking pork*”. The response sentence must be AV-marked to be felicitous, as the agent *Sawmah* is the topic of the discourse and must be marked as the Pivot (6-A1). The PV sentence (6-A2), which marks the Theme as the Pivot, is considered unnatural by speakers.

(6) *The discourse topic as the Agent of a response to a question: Amis*

Q: Discourse topic: Sawmah

mi-maan ci sawmah?

AV-whatPN.PIVOT Sawmah

‘What is *Sawmah* doing?’ [Context: asking in phone]

A1: (✓) *The discourse topic is Pivot-marked*

mi-tangtang **cingra** tu titi.

AV-cook **3SG.PIVOT** Y pork

‘*She* is cooking pork.’

A2: (✗) *The discourse topic is not Pivot-marked*

mi-tangtang-**an** nira **ku** **titi**.

PV⁵.hit=PFV 3SG.X **PIVOT** **pork**

(‘*She* is cooking *pork*.’)

⁵ The verb *mi-tangtang-an* in (9) is morphologically in LV, but takes a PV argument structure and marks the Theme as the Pivot. For the purpose of this data set, I gloss it as “PV”.

Question-answer sequences from Seediq (7)-(8), Puyuma (9)-(10), and Tagalog (11)-(12) show the same pattern. In all three languages, the discourse topic indicated by the context must be “Pivot”-marked, with the sentence in the appropriate voice type:

(7) *The discourse topic as the Theme of a response to a question: Seediq*

Q: Discourse topic: Robo

h<m>uwa ka robo di?
 what.happen<AV> PIVOT Robo PART
 ‘What happened to *Robo*?’ [Context: seeing *Robo* crying]

A1: (✓) *The discourse topic bears Pivot-marking*

s<n>ebuc na temi ka heya.
 <PRF.PV>hit X Temi PIVOT 3SG
 ‘Temi hit *her*.’

A2: (✗) *The discourse topic is not Pivot-marked*

s<m><n>ebuc Ø heya ka temi.
 <AV><PRF>hit Y 3SG PIVOT Temi
 (‘Temi hit *her*.’)

(8) *The discourse topic as the Agent of a response to a question: Seediq*

Q: Discourse topic: Robo

h<m>uwa ka robo?
 <AV>do.what PIVOT Robo
 ‘What did *Robo* do today?’ [Context: asking in phone]

A1: (✓) *The discourse topic bears Pivot-marking*

t<m><n>inun Ø lukus ka heya.
 weave<AV><PRF> Y clothes PIVOT 3SG
 ‘She wove clothes.’

A2: (✗) *The discourse topic is not Pivot-marked*

wada tinun-un na heya ka lukus.
 PRF weave-PV X 3SG PIVOT clothes
 (‘She wove clothes.’)

(9) *The discourse topic as the Theme of a response to a question: Puyuma*

Q: Discourse topic: Senten

makakuta i senten?
 AV.what.happen SG.PIVOT Senten
 ‘What happened to *Senten*?’ [Context: seeing *Senten* crying]

A1: (✓) *The discourse topic bears Pivot-marking*

tu_i=pukpuk-aw pro kan pilay_i.

3.X_i=hit-PV (3SG.PIVOT) SG.X Pilay_i
 ‘Pilay hit (*her*).’

A2: (✗) *The discourse topic is not Pivot-marked*

p<en>ukepuk i pilay (kantaw).
 hit<AV> SG.PIVOT Pilay (3SG.Y)
 (‘Pilay hit her.’)

(10) *The discourse topic as the Agent of a response to a question: Puyuma*⁶

Q: *Discourse topic: Senten*

ma-tra-trangis i senten dra manay?
 AV.RED-cry SG.PIVOT Senten ID.Y what
 ‘What is *Senten* crying about?’ [Context: *seeing Senten crying*]

A1: (✓) *The discourse topic is Pivot-marked*

me-na’u (taytaw) dra lalaib.
 AV-see (3SG.PIVOT) ID.Y cockroach
 (‘*She* saw cockroaches.’)

A2: (✗) *The discourse topic is not Pivot-marked*

tu=na’u-ay na lalaib.
 3.X=see-LV DF.PIVOT cockroach
 (‘She saw *the cockroaches*.’)

⁶ In Puyuma, the question “What happened to X?” is not an ideal diagnostic for the current purpose, as progressive aspect can only be expressed in AV-clauses (A1). Therefore, the unacceptability of the PV sentence A2 can be attributed to its incompatibility with the progressive aspect.

Q: *Discourse topic: Senten*

makakuta i senten?
 AV.what.happen SG.PIVOT Senten
 ‘What is *Senten* doing?’ [Context: *asking in phone*]

A1: (✓) *The discourse topic is Pivot-marked*

da-deru pro dra abay.
 <AV>RED-cook 3SG.PIVOT ID.Y rice.ball
 (‘*She* is cooking sticky rice balls.’)

A2: (✗) *The discourse topic is not Pivot-marked*

tu=deru-aw na abay.
 3.X=cook-PV DF.PIVOT rice.ball
 (‘*She* is cooking the *sticky rice balls*.’)

(11) *The discourse topic as the Theme of a response to a question: Tagalog*⁷

Q: *Discourse topic: Ivan*

ano-ng nang-yari kay ivan?
what-LK AV-happen P Ivan
'What happened to *Ivan*?' [Context: seeing *Ivan* sigh]

A1: (✓) *The discourse topic bears Pivot-marking*

s<in>isi siya ni wiliam.
scold<PV.PRF> 3SG.PIVOT PN.X William
'William scolded *him*.'

A2: (✗) *The discourse topic is not Pivot-marked*

s<um>isi si wiliam sa kanya.
scold<AV> PN.PIVOT William DF.Y 3SG.Y
(*'William* scolded *him*.)

(12) *The discourse topic as the Agent of a response to a question: Tagalog*

Q: *The discourse topic: apple*

ano-ng nang-yari sa mansanas?
what-LK AV-happen P apple
'What happened to *the apple*?'
[Context: returned to the office and saw the apple on the desk had a bite taken out of it]

A1: (✓) *The discourse topic bears Pivot-marking*

k<in>ain ni sejung (ang mansanas).
blame<PV.PRF> PN.X Sejung (PIVOT apple)
'Sejung ate *the apple*.'

A2: (??) *The discourse topic is not Pivot-marked (acceptable, but A1 is preferred)*

k<um>ain si sejung ng mansanas.
eat<AV> PN.PIVOT Sejung ID.Y apple

⁷ Richards (2000) discusses results from a similar diagnostic in Tagalog with the following data, and notes that a discourse topic in Tagalog is not necessarily Pivot-marked. As seen in A1, the Agent Juan, which is the presumed discourse topic, is marked with X, the nominative, with Pivot-marking shown on the object 'dishes'.

Q: *Discourse topic: Juan*
na saan si juan?
NA where PN.PIVOT Juan
'Where is *Juan*?'

A1: *The discourse topic is not put as the Pivot*
h<in>u-hugas-an niya ang mga pinggan.
<PRF>wash-an 3SG.X PIVOT PL dish
'He is washing *the dishes*.'

However, two Tagalog speakers I consulted both commented that the sentence in (A1) is not well-formed as the answer to the question "Where is Juan?", and they provided the sentence in (A2), in which the discourse topic 'Juan' bears Pivot status:

A2: nag-hu-hugas-an siya ng mga pinggan.
<PRF.PV>RED-wash 3SG.PIVOT ID.Y PL dish
'*He* is washing the dishes.'

The potential variation in speakers' judgement of (A1) could be due to the fact that the question "Where is Juan" does not indicate a discourse topic as clearly as that in the question used in previous tests "What happened to Juan?".

(‘*Sejung* ate the apple.’)

The data above suggests a connection between topichood and the placement of “Pivot”-marking. This generalization is further supported by the Tagalog data in (13) below. In response to the question “*Where is Ivan’s spoon?*”, my Tagalog consultant provided four possible answers (A1)-(A4), all of which place the discourse topic ‘*Ivan’s spoon*’ as the Pivot. In A1 “*Victoria is using it*”, the topic is the Theme and can be optionally realized as a silent pronoun. The sentence must be marked in PV, with the topic bearing Pivot status. In A2 “*Ryan is eating with it*”, the topic is the Instrument of the clause. The sentence must be marked in CV, with the topic Pivot-marked. A similar observation obtains with A3 “*I saw that Amber stole it*”, where the topic is the Pivot of the embedded PV clause. Finally, in A4 “*The spoon is with Kirsten*”, the sentence identifies the location of the topic, with the topic *spoon* marked as the Pivot.

(13) *Pivot placement in question-answer sequence: Tagalog*

Q: Discourse topic: Ivan’s spoon

na	saan	ang	kutsara	ni	ivan?
NA	where	PIVOT	spoon	PN.POSS	Ivan

‘Where is *Ivan’s spoon*?’

A1: The discourse topic is put as the Pivot in a PV clause

gamit	ni	viktoria	(ang	kutsara).
use.PV	PN.X	Victoria	(PIVOT	spoon)

‘Victoria is using *it (/the spoon)*.’

A2: The discourse topic is put as the Pivot in a CV clause

i-p<in>	ang-ka-kain	ni	ryan	(ang	kutsara).
CV-<PRF>	PANG-RED-eat	PN.X	Ryan	(PIVOT	spoon)

‘Ryan is eating with *it (/the spoon)*.’

A3: The discourse topic is put as the embedded Pivot in a complex sentence

na-kita=ko=[ng	k<in>uha	ni	amber	(ang	kutsara)].
PRF.PV ⁸ -see=1SG.X=[LK	steal<PV.PRF>	PN.X	Amber	(PIVOT	spoon)]

‘I saw that Amber stole *it (/the spoon)*.’

A4: The discourse topic is put as the Pivot in a non-verbal predicate

na	kay	kirsten	ang	kutsara.
NA	with	Kirsten	PIVOT	spoon

‘*The spoon* is with Kirsten.’

⁸ Experiencer verbs such as *na-kita* ‘see’ in Tagalog obligatorily take a Genitive (X)-marked experiencer. For the sake of clarity, I gloss the sentence as PV accordingly, as it takes a PV-like argument-marking structure.

The observations above consistently suggest a close correlation between topichood and Pivot-selection, which strongly suggests that Pivots are topics.

5.2.3 Argument 2: Pivots share the same marker with hanging topics

The second argument for the current analysis comes from the shared morphological marking between Pivots and hanging topics.

Philippine-type languages commonly employ a sentence-initial position that shows the hallmarks of a hanging topic position. Three types of phrases that carry old information or a topic are commonly observed in this slot: (i) specific/definite DPs, (ii) generic DPs, or (iii) adjuncts. These sentence-initial topics consistently share morphological marking with Pivot phrases.⁹ See the data below from Puyuma (14), Paiwan (15), and Cebuano (16), languages from three different primary branches of Austronesian:

(14) *Shared morphological marking between hanging topics and Pivots: Puyuma*

- a. adei sagar i siber kan akang.
 NEG like.AV SG.PIVOT Siber SG.Y Akang
 ‘Siber dislikes Akang.’
- b. **i/*kan akang i adri sagar i siber.**
 “SG.PIVOT”/*SG.Y Akang PART NEG like.AV SG.PIVOT Siber
 ‘Akang, Siber dislikes (her).’

(15) *Shared morphological marking between hanging topics and Pivots: Paiwan*

- a. d<in>ukuL ti kui ni zepul.
 hit<PV.PRF> SG.PIVOT Kui X Zepul
 ‘Zepul has hit Kui.’
- b. **ti/*ni zepul d<in>ukuL ti kui.**
 “SG.PIVOT”/*SG.X Zepul hit<PV.PRF> SG.PIVOT Kui
 ‘Zepul, (she) has hit Kui.’ (Chang 2006:417–18)

(16) *Shared morphological marking between hanging topics and Pivots: Cebuano*

- a. gi-higugma ni juan si maria.
 PV-love PN.X Juan PN.PIVOT Maria
 ‘Juan loves Maria.’
- b. **si/*ni juan gi-higugma (niya) si maria.**
 PN.PIVOT/*PN.X Juan PV-love (3SG.X) PN.PIVOT Maria
 ‘Juan, (he) loves Maria.’ (Shibatani 1988:131)

⁹ To the best of my knowledge, all Philippine-type languages that employ overt marking for hanging topics employ the same marker (i.e., “Pivot”) for the Pivot phrase.

The base-generated status of the sentence-initial topics (14b), (15b), and (16b) is evidenced by their lack of case connectivity effect, suggesting that these phrases are *hanging (external) topics* (see, e.g., Aissen 1992; Anagnostopoulou 1997; Legate 2002; Zeller 2009; Miyagawa to appear) base-generated in the left periphery.¹⁰ The fact that the “Pivot” phrases share morphological marking with hanging topics thus provides additional evidence for the topic analysis of these phrases.

5.2.4 Argument 3: “Pivot” marks presupposed information in pseudo-clefts

The third piece of evidence for the current analysis comes from the argument-marking pattern in pseudo-cleft constructions.

Pseudo-clefts in Philippine-type languages are formed by a sentence-initial predicate and a following presupposed clause. New information (focus) is usually introduced as the predicate, with given information placed in the presupposed clause. The predicate and the presupposed clause are connected by a marker, conventionally labeled as a copula or a linker in the Austronesian literature.¹¹ This is illustrated in (17) and the following data (18a)-(d):

- (17) Focus linker {Presupposed clause}
 └──────────┘ └──────────────────────────┘
 new information old information

(18) *Pseudo-cleft constructions in Puyuma, Amis, Seediq, and Tagalog*

- a. (amaw) i senten **na** [trima dra ruma], ameli i sayki. [Puyuma]
 (COP) PN.PIVOT Senten **LK** [buy<AV> ID.Y house], NEG.COP PN.PIVOT Sayki
 ‘It is Senten *who bought a house*, not Sayki.’

¹⁰ The base-generated status of such sentence-initial topics is additionally informed with observations from Puyuma, that such topics are immune to islands (e.g., (a)) and lack reconstruction effects (e.g., (b)-(c)):

- (a) **na** **walak** i ma-ladram=ku [kana ngay [dra tu=pukpuk-aw na suwan]].
DF.PIVOT **child** PART AV-know=1SG.PIVOT [DF.Y rumor [C 3.X=hit-PV SG.PIVOT dog]]
 ‘(As for) the child, I know the rumor that (he/she) hit the dog.’
- (b) sagar na taynaynayan driya kantu=walak.
 like.AV DF.PIVOT mothers every 3.POSS.Y=child
 ‘Every mother<i> likes her</i> child.’ (✓ bound variable reading)
- (c) **tu=walak** i sagar na taynaynayan driya.
3.POSS.PIVOT=child PART like.AV DF.PIVOT mothers every
 ‘Her child<i>, every mother</i> likes.’ (X bound variable reading)

¹¹ Drawing on evidence from Puyuma and Tsou for the presence of a sentence-initial copula in pseudo-clefts, I argue that the linker is not a copula.

- (amaw) imanay **na** [sagar m-ekan dra bu’ir]?
 (COP) who **PIVOT** [like.AV AV-eat ID.Y taro]
 ‘Who is the one that likes to eat taro?’

- b. ci kulas **ku** [mi-palu-ay tisuwanan], anu ci panay? [Amis]
 PN.PIVOT Kulas **LK** [AV-hit-AY 2SG.Y], or PN.PIVOT Panay
 ‘Is it Kulas *who hit you*, or is it Panay?’
- c. ye walis **ka** [b<n>eebu Ø isu], ye watan? [Seediq]
 Q Walis **LK** [<PV.PRF>hit Y 2SG], Q Watan?
 ‘Is it Walis *who hit you*, or is it Watan?’
- d. si Ivan **ang** [b<um>ili ng kendi], hindi si viktoría. [Tagalog]
 PN ivan **LK** [buy<AV> ID.Y candy], NEG PN.PIVOT Victoria
 ‘It is Ivan *who bought candy*, not Victoria.’

Importantly, while the form of “Pivot” varies across languages, the linker that introduces the presupposed clause consistently shares a form with “Pivot”-marking. This is seen in the table in (19) and exemplified with Tagalog data in (20):

(19) TABLE 5.2. *The shared morphological form between Pivot-marking and the linker in pseudo-clefts*¹²

	Pivot-marking	Linker form in pseudo-clefts
a. Puyuma	<i>na/i</i>	<i>na/i</i>
b. Amis	<i>ku</i>	<i>ku</i>
c. Seediq	<i>ka</i>	<i>ka</i>
d. Kavalan	<i>ya</i>	<i>ya</i>
e. Paiwan	<i>a</i>	<i>a</i>
f. Ilocano	<i>ti</i>	<i>ti</i>
g. Tagalog	<i>ang</i>	<i>ang</i>
h. Botolan Sambal	<i>ya</i>	<i>ya</i>
i. Malagasy	Ø	Ø

(20) *The shared marking of the presupposed clause in pseudo-clefts and the Pivots*

- a. [pusa ni ivan] **ang** [k<um>agat sa aso ni peter]. [Tagalog]
 [cat PN.POSS Ivan] **PIVOT** [<AV> DF.Y dog PN.POSS Peter]
 ‘It is Ivan’s cat *that bit Peter’s dog*.’ [Context: seeing Peter’s dog wounded]
- b. ma-tabá **ang** [aso ni juan].
 AV.STAT-fat **PIVOT** [dog PN.POSS Juan]
 ‘Juan’s dog is fat.’

Given the observations above, I argue that pseudo-clefts in Philippine-type languages can be analyzed as a topic-comment structure. Under this analysis, the presupposed clause is the *topic* of the construction, marked with “Pivot”-marking, with the predicate denoting the *focus* of the construction:

¹² Source: Puyuma (Teng 2008, primary data); Amis (D. Lin 2013, primary data); Seediq (Tsukida 2009, primary data); Kavalan (D. Lin 2013); Paiwan (Chang 2006); Malagasy (Pearson 2001); Ilocano (Rafal 2009); Botolan Sambal (Antworth 1979).

- (21) $\underbrace{\text{Focus}}_{\text{Comment}}$ Pivot $\underbrace{\{\text{Presupposed clause}\}}_{\text{Topic}}$

This analysis is supported by the data below from Puyuma, Amis, Seediq, and Tagalog. All data were elicited with a context provided by me. As seen in (22)-(25), across the four languages, the focus (i.e., new information) is consistently placed in the predicate of the cleft. The given information is always placed in the presupposed clause, marked with “Pivot”-marking:¹³

(22) *The placement of foci and topics in pseudo-clefts: Puyuma*

Q: Context: asking a family member about the family dog

[isuwa] na [suwan]?
[where] PIVOT [dog]
'Where is the dog?'

A: [ulaya i sawka] (na suwan).
[EXI LOC kitchen] (PIVOT dog)
'(The dog) is in the kitchen.'

(23) *The placement of foci and topics in pseudo-clefts: Amis*

Q: Context: overheard Panay and Sawmah talking about a person named Kulas

[cima] ci [Kulas]?
[who] PN.PIVOT [Kulas]
'Who is Kulas?'

A: [u mitililday aku] ci [Kulas].
[DET student 1SG.POSS] PN.PIVOT [Kulas]
'Kulas is my student.'

¹³ It is noteworthy that Kroeger (1993) raises doubts about the topic analysis of the Pivot by showing that putative 'topics' in Tagalog can bear pragmatic focus. For instance, he notes that in answering the *wh*-question below, both A1 and A2 are acceptable, suggesting both both topic and focus can be “Pivot”-marked.

Q: ano ba ang b<in>ili=mo sa pamilihan?
what Q PIVOT <PV.PRF>=2SG.X DF.Y market
'What did you buy at the market?'

A1: b<in>ilih=ko itong damit.
<PV.PRF>buy=1SG.X this.PIVOT dress
'I bought this dress.'

A2: b<um>ilih=ako ng gatas.
<AV>buy=1SG.PIVOT ID.Y milk
'I bought some milk.' (Kroeger 1993:63)

However, two Tagalog speakers I consulted commented that the best answer to this question is a pseudo-cleft (A3), with the focus put as the predicate and the old information placed within the presupposed clause marked by “Pivot”:

A3: ito=ng damit ang b<in>ilih=ko.
this=LK dress PIVOT <PV.PRF>buy=1SG.X
'This dress is what I bought.'

I remain agnostic about this potential issue raised by Kroeger, and tentatively assume that the most accurate answer to this question does not constitute a counterexample to the distribution of “Pivot”-marking.

(24) *The placement of foci and topics in pseudo-clefts: Seediq*

Q: Context: seeing my son playing with a boy

[ima] ka [heya]?
[who] PIVOT [3SG]
'Who is he?'

A: [tangi=mu] ka [heya].
[friend=1SG.POSS] PIVOT [3SG]
'He is my friend.'

(25) *The placement of foci and topics in pseudo-clefts: Tagalog*

Q: Context: saw Ivan walking with a woman

sino ang [babae=[ng naglakad kasama ni ivan]]?
[who] PIVOT [woman=[LK AV.PRF-walk with PN.X Ivan]]
'Who is the woman who walked with Ivan?'

A: [nanay niya] ang [babae=ng iyon].
[mother 3SG.POSS] PIVOT [woman=LK that]
'That woman is his mother.'

Given the observations above, I conclude that “Pivot”-marking is best analyzed as a general topic marker, which marks both hanging topics and internal topics, as well as the presupposed clause of pseudo-clefts (i.e., the topic in a topic-comment construction).¹⁴

5.2.5 Claim: “Pivot”-marking overrides morphological case

In this subsection, I discuss two questions arising from the current analysis: (i) the relationship between Pivots and hanging topics, and (ii) how “Pivot”-marking interacts with morphological case.

I argue that Pivots in Philippine-type languages are the internal topics of the clause, as opposed to sentence-initial hanging topics, which are *external topics* base-generated extra-sententially.¹⁵

I further propose that both types of topic carry the morphological marker “Pivot”, because “Pivot” is the morphological reflex of the [topic]-feature. This analysis is illustrated in (26):

(26) (External topic_[Top]) [C T Internal topic_[Top]] *[TOP] spelled out as “Pivot”*

¹⁴ A similar claim was made by Pearson (2001:133), that Malagasy pseudo-clefts function as a topic-comment construction.

¹⁵ See Section 5.2.3 for evidence for the base-generated status of sentence-initial hanging topics in languages like Puyuma, Paiwan, and Cebuano.

I also argue that when a phrase is case-marked as well as topic-marked, only the marking for topic is morphologically realized.

(27) In Philippine-type languages, topic-marking (“Pivot”) overrides morphological case.

The argument-marking mechanism of Philippine-type languages under the current analysis is illustrated in (28): in AV-clauses, the external argument bears topic status. Therefore, it carries the topic marker “Pivot”, which morphologically overrides nominative case, X (28a). In PV-clauses, the internal argument bears topic status. Thus, its accusative case is overridden by “Pivot”-marking (28b). In LV-/CV-marked clauses, a Locative or Instrument/Benefactive phrase bears Pivot status. Therefore, their preposition or oblique Case is overridden by “Pivot”-marking (28c)-(d), with the external and internal arguments bearing their morphological case, nominative and accusative, respectively.

(28) *TABLE 5.3. Proposal: the nature of the shared argument-marking pattern in Philippine-type languages*

	(a) AV	(b) PV	(c) LV	(d) CV
External argument	Nominative Topic	Nominative	Nominative	Nominative
Internal argument	(Accusative)	Accusative Topic	(Accusative)	(Accusative)
Location	(Locative)	(Locative)	Locative Topic	(Locative)
Instrument/benefactor	(Oblique)	(Oblique)	(Oblique)	Oblique Topic

Under the current analysis, then, all the differences in argument-marking between AV and non-AV clauses boils down to *the selection of the internal topic of a clause*.¹⁶

5.2.6 Interim conclusion

I have argued that “Pivot”-marking in Philippine-type languages is best analyzed as a topic marker. Empirical support for this analysis comes from the observation that across Puyuma, Amis, Seediq, and Tagalog, that the discourse topic of a clause must bear “Pivot”-marking (5.2.2), as well as the fact that unambiguous cases of topics in Philippine-type languages—including sentence-initial hanging topics and the presupposed clause of pseudo-clefts—share the same morphological marking with Pivot phrases (5.2.3–4).

¹⁶ Namely, there is no asymmetry between AV and non-AV clauses in terms of transitivity, Case-licensing, or the presence or absence of an EPP feature on Voice. This analysis is consistently with two conclusions from Chapter 4: (i) Philippine-type LV and CV clauses do not involve an applicativizing operation of the Pivot phrase, and (ii) a Pivot is an adjunct in LV/CV clauses. Note, however, that Tagalog exhibits potential evidence for Object Shift, which, under Rackowski & Richards (2005), is accounted for by assuming an EPP on v (Voice). See specific details in Rackowski & Richards (2005:568). These characteristics, however, are not found in most Philippine-type languages.

I then argued in 5.2.5 that Pivots are best analyzed as internal topics, as opposed to hanging topics, which are base-generated as extra-sentential topics. I showed that the argument-marking pattern of Philippine-type languages can be accounted for by the simple explanation that “Pivot”-marking overrides morphological case.

5.3 The nature of the Philippine-type voice affixes

I now turn to an important question that has so far remained unaddressed, namely the nature of the Philippine-type voice affixes. As seen in the preceding discussions, in Philippine-type languages, there is a fixed correspondence between Pivot-selection and the voice-marking in a clause. In this section, I investigate the following three questions:

- (29) a. What do Philippine-type voice affixes morphologically encode?
b. What is the nature of the four-way division of Philippine-type voice morphology?

If the topic analysis of the Pivot presented in Section 5.2 is on the right track, Philippine-type voice affixes can be descriptively viewed as *topic-indicating morphemes* that cross-reference the selection of the internal topic of a clause. Building on this, I argue that these affixes are best analyzed as *topic-indicating agreement morphology* obligatorily present in each clause. In approaching this analysis, I put forward the proposal in (30):

- (30) Philippine-type languages are *topic-prominent* languages (Li & Thompson 1976; Sasse 1995). They employ both *morphological marking* for topics and *articulated verbal morphology* to index the topic in a clause.

This section is structured as follows. I first summarize the main traits of Philippine-type voice affixes in 5.3.1. I then review previous analyses of these affixes in 5.3.2 and point out some of their problematic issues. In 5.3.3, I lay out my analysis of the voice affixes, and present evidence for the proposed analysis in 5.3.4.

5.3.1 Main traits of the Philippine-type voice affixes

I begin by introducing three important traits of the Philippine-type voice affixes (31a)-(c):¹⁷

- (31) *Typical traits of Philippine-type voice affixes*
a. Philippine-type voice affixes inflect for both the selection of topic and mood.

¹⁷ Here, I am concerned with only the prototypical traits of these affixes that are observed across the majority of Austronesian primary branches. Therefore, I exclude some facts in innovative languages where some of these traits have been lost.

- b. Every lexical verb must carry one and only one voice affix. The voice affix on all non-highest lexical verbs in a sentence shows morphological restrictions.¹⁸
- c. In A'-extraction, the voice affix must indicate the extracted phrase as the Pivot, known as the "Pivot-only" constraint in A'-extraction.

5.3.1.1 Two types of inflection in Philippine-type voice morphology

It is well-known that Philippine-type voice morphology shows a four-way distinction conditioned by the selection of the Pivot in a clause, conventionally called *Actor voice (AV)*, *Patient voice (PV)*, *Locative voice (LV)*, and *Circumstantial voice (CV)*. The table below summarizes the mapping between voice-marking and Pivot selection in six basic constructions. The structural position of the Pivot in each construction is indicated by the subscript.

(32) TABLE 5.4. The thematic role and structural position of the Pivot in types of basic constructions

	(a) AV	(b) PV	(c) LV	(d) CV
1. Transitives	Agent _[Spec VoiceP]	Theme _[V Comp]	Tem/Loc _[PP]	Ben/Inst/Reason ... _[PP]
2. Unergatives	Agent _[Spec VoiceP]	—	Tem/Loc _[PP]	Ben/Inst/Reason ... _[PP]
3. Unaccusatives	Theme _[V Comp]	—	Tem/Loc _[PP]	Ben/Inst/Reason ... _[PP]
4. Statives	Experiencer _[V Comp]	—	—	—
5. Causatives	Causer _[Spec VoiceP]	Causee _{2nd [Spec VoiceP]}	Tem/Loc	Causand _{2nd [V Comp]}
6. Ditransitives	Agent _[Spec VoiceP]	Recipient _[Spec AppIP]	Goal/Source	Theme _[V Comp]

As seen above, in clauses with the same voice-marking, phrases that are eligible to serve as the Pivot vary both in their base-generated position and case status. In a PV-clause, for instance, a possible Pivot could be an internal argument (in a simple transitive clause), an embedded external argument (in a productive causative), or an applied object (in a ditransitive) (32b). Similarly, in a CV clause, either a DP that is structurally low (e.g., the Causand in a productive causative or the Theme in a ditransitive) or a PP (e.g., an Instrument or Benefactor) may serve as the Pivot (32c)-(d). The nature of this seemingly irregular mapping will be further discussed in Section 5.3.3.

Given comparative evidence from languages under seven of the ten Austronesian primary branches, there has been a consensus that prototypical Philippine-type voice morphology also inflects for at least three moods: (a) indicative, (b) optative/hortative, and (c) imperative/negative. This is

¹⁸ This generalization excludes sporadic cases where a voice affix is morphologically null. For instance, in many Philippine-type languages, a small number of AV-verbs do not carry an overt AV affix. The voice status of such verbs is indicated by the argument-marking pattern they take, i.e., the selection of the Pivot in the clause. For instance, the zero-marked verb in (a) is standardly analyzed as in AV, as "Pivot"-marking falls on the external argument; the zero-marked verb in (b) is commonly analyzed as in PV, as "Pivot"-marking falls on the internal argument:

- a. *sagar i senten dra aputr.* [Puyuma] b. *gusto ni ivan ang pusa.* [Tagalog]
 "AV".like SG.PIVOT Senten ID.Y flower like."AV" PN.X Ivan PIVOT cat
 'Senten likes flowers.' 'Ivan likes cats.'

illustrated with the Proto-Austronesian reconstructions in (35) (see Wolff 1973; Ross 2009, 2012, and Chapter 7):

(33) TABLE 5.5. *Mood inflections in Proto-Austronesian voice morphology*

	Actor voice	Patient voice	Locative voice	Circumstantial voice
a. indicative	*<um>	*-en	*-an	*Si-/Sa-
b. optative, hortative	*-a	*-aw	*-ay	*-anay
c. imperative, negative	*-Ø	*-u	*-i	*-an

Evidence for these reconstructions is illustrated with the Atayal data (34). As seen below, when a PV-sentence in Paiwan is in indicative, optative, or imperative mood, the PV morphology appears in three different forms: *-un* (34a), *-aw* (34b), and *-i* (34c). In negative indicative clauses, the voice morphology patterns with that in the imperative, as seen in (34c)-(d):¹⁹

(34) *Mood inflections in Atayal Patient voice*

- a. na-niq-**un**=mu ku siyam. [PV indicative: -un]
 CA.RED-eat-PV.IND=1SG.X PIVOT pork
 'I will eat the pork.' (Huang 2001:64)
- b. niq-**aw**=mu ku siyam!
 eat-PV.OPT=1SG.X PIVOT pork
 'If only I could eat the pork!'
- c. niq-**i** ku sehuy!
 eat-PV.IMP PIVOT taro
 'Eat the taro!' (Huang 2001:64) [PV imperative: -i]²⁰
- c' **ini**=nya niq-**i** ku sehuy.
 NEG=3SG.X eat-PV.NEG PIVOT taro [PV negative: -i]

¹⁹ In less conservative Philippine-type languages such as Tagalog, indicative and imperative clauses show no morphological distinction, as seen below in (a)-(b). In addition, to the best of my knowledge Tagalog does not exhibit an optative/hortative construction equivalent to (40b).

- a. ka-kain-**in** ni ivan ang gabi.
 CONT-eat-PV PN.X Ivan PIVOT taro
 'Ivan will eat the taro.' [PV indicative: -in]
- b. kain-**in**=mo ang gabi!
 eat-PV=2SG.X PIVOT taro
 'Eat the taro!' [PV imperative: -in]

This generalization also excludes observations from more innovative Philippine-type languages, which possess relatively high amounts of verbs that are zero-affixed. In such cases, the voice status of a clause is indicated by the argument-marking pattern it takes. See, for example, the data below from Blaan (Bondoc 2015):

- a. dj!h ʔa'gu 'fagu_di j'"#l #u'l\$n.
 (AV).bathe 1SG.PIVOT INS.M water rain
 'I take a bath using rain water.'
- b. dj!h gu ʔi jε'ʔel ʔu'lən.
 (CV).bathe 1SG.X PIVOT water rain
 'I take a bath using rain water.' (Bondoc 2015:52)

As the loss of an overt voice affixes in such cases is clearly a product of secondary innovations, I do not consider it a core trait of the Philippine-type voice system.

²⁰ As will be discussed in Chapter 9, many languages have lost the distinction between PV imperative *-u* and LV imperative *-i*, including Atayal. It can nevertheless be seen that Atayal exhibits a three-way distinction in mood inflection.

‘He didn’t eat the taro.’

5.3.1.2 Voice-marking restrictions on non-highest lexical verbs

In a prototypical Philippine-type voice system, every lexical verb must carry one and only one voice affix, whereas the voice-marking of any non-highest verb within a CP shows two types of morphological restrictions.²¹ In languages under five of the ten Austronesian primary branches (Paiwan, Puyuma, Atayalic, East Formosan, Western Plains), Actor voice is the only available voice-marking on all non-main verbs in a sentence. This constraint is known as “*AV-only*”, and is illustrated in (35):²²

(35) *The voice-marking restriction on non-highest lexical verb within a CP in Amis*

- a. mi-aca’ kaku t-una haha Ø-pafeli ci Lisin-an. [AV-AV]
 AV-buy 1SG.PIVOT Y-that flower AV-give PN Lisin-Y
 ‘I bought that flower (and) gave it to Lisin.’
- b. **mi**-aca’-**an**²³ ako k-una hana Ø-beray ci lisin-an. [PV-AV]
 buy-LV[PV] 1SG.X PIVOT-that flower AV-give PN Lisin-Y
 ‘I bought that flower (and) gave it to Lisin.’
- c. **mi**-dukduk ci putun a **mi**-sanga’ tu ‘cucul i luma’. [AV-AV]
 AV-secretly PN.PIVOT Putun LK AV-make Y whipping.top LOC house
 ‘Putun secretly made whipping tops at home.’ (ODFL)
- d. dukduk-(h)**an** nira a **mi**-ala ku paysu ni ina nira. [PV-AV]
 secretly-LV[PV] 3SG.X LK AV-take PIVOT money PN.X mother 3SG.POSS
 ‘He secretly took his mother’s money.’ (ODFL)

Another group of languages employs a different constraint known as “*Voice-concord*”, whereby the voice-marking of the non-main verbs must pattern with that of the main verb. This constraint is found in Tsou, Saisiyat, and Isbukun Bunun, as well as the Malayo-Polynesian languages Kimarakang Dusun and Chamorro. See the data below from Saisiyat:²⁴

²¹ These restrictions are found in all Philippine-type Formosan languages (Puyuma, Paiwan, Tsou, Saaroa, Atayal, Seediq, Paiwan, Bunun, Amis, Kavalan, Saisiyat), as well as the Malayo-Polynesian languages Chamorro. Such a constraint, however, is not observed in many Philippine languages like Tagalog and Cebuano. The absence of this phenomenon in Tagalog could be attributed to the analysis that infinitives in Tagalog are as large as a CP (Wurmbrand 2014), as they can host different voice affixes.

²² Sources: Atayal (T.-C. Chen 2010), Seediq, Amis, Seediq (Chen & Fukuda 2016), Kavalan (D. Lin 2013), Paiwan (Wu 2013), Kimarakang Dusun (Kroeger 2008, 2014), and Takibakha Bunun (Shi 2014).

²³ In Amis, a number of verbs take an LV-form, while others take a PV argument structure. See Wu (2006) for details. For the purpose of the current discussion, I gloss them as *LV[PV]*.

²⁴ Sources: Chamorro (Chung 2004), Tsou (G. Lin 2010), Bunun (Wu 2011); Saisiyat (Yeh 2016); Kimaragang Dusun (Kroeger 2014).

(36) *Voice-marking restriction on non-highest lexical verb within a CP in Saisiyat*

- a. yako rengreng **m-wa:i'** k<**om**>ita' hi koko'. [AV-AV]
 1SG.PIVOT often AV-come see<AV> PN.Y grandmother
 'I often come see grandma.'
- b. kayba:en ni 'oya' mari'-**en** 'araS-**en** baehi'-**en** ila. [PV-PV-PV]
 clothes PN.X mother take-PV bring-PV wash-PV PRF
 'The clothes, mother has taken (them) and brought them to wash.'
- c. yako t<**om**>owa'is '**<om>**itol, siya 'isa:a' min'itol ila.²⁵ [AV-AV]
 1SG.PIVOT constantly<AV> call<AV>, 3SG.PIVOT then wake.up.AV PRF
 'I constantly called (him), and then he got up.'
- d. nisiya koSa'-en towa'is-**en** singozaw-**en** ni towanay. [PV-PV]
 3SG.X say-PV constntly-PV ask-PV PN.X sister.in.low
 'He did not say (it) until his sister-in-law constantly asked about (it).' (Yeh 2016:174–6)

As the data above indicates, regardless of the exact strategy employed by individual languages (i.e., AV-only or Voice-concord), these morphological restrictions on the non-main verbs in a sentence are manifested in both serial verb constructions and adverbial-verb constructions above, as both constructions contain multiple verbs within a CP.²⁶

5.3.1.3 *Voice-marking restriction in A'-extraction*

Finally, Philippine-type voice affixes show a special morphological constraint in A'-extraction known as "Pivot-only", whereby the voice morphology in relative clauses must identify the extracted phrase as the Pivot. This is illustrated with the Tagalog and Seediq data (37)-(38):

(37) *The "Pivot-only" constraint in A'-extraction: Tagalog*

- a. sino ang [b<**um**>ili/*-in/*-an/*i- ng gulay]? [Extraction of the external argument]
 who PIVOT [<AV>Bnuy/*PV/*LV/*CV ID.Y vegetable]
 'Who is the one that bought vegetables?'
- b. ano ang [bi-bilih-**in**/*<um>/*-an/*i- ni ivan]? [Extraction of the internal argument]
 what PIVOT [CONT-buy-PV/*AV/*LV/*CV PN.X Ivan]
 'What is the thing that Ivan will buy?'
- c. nasaan ang [bi-bilih-**an**/*<um>/*-an/*i- ni ivan ng gulay]? [Extraction of location]
 where PIVOT [CONT-buy-LV/*AV/*PV/*CV PN.X Ivan ID.Y vegetable]
 'Where will Ivan buy vegetables?'
- d. sino ang [i-bi-bili/*<um>/*-**in**/*-**an** ni ivan ng gulay]? [Extraction of benefactor]
 who PIVOT [CV-CONT-buy/*AV/*PV/*LV PN.X Ivan ID.Y vegetable]

²⁵ Due to a lack of data from Isbukun Bunun, (43c)-(d) are not structurally identical to the Puyuma SVC data in (42c)-(d).

²⁶ In most Philippine-type Formosan languages, the majority of manner adverbs behave like typical verbs and carry voice-marking. See Starosta (1988/2009) for details.

‘Who will Ivan buy vegetables for?’

(38) *The “Pivot-only” constraint in A’-extraction: Seediq*

- a. ima ka [s<m><n>eeliq/*-un/*-an/*s- Ø rodux]? [Extraction of the external argument]
who PIVOT [<AV><PRF>butcher/*PV/*LV/*CV Y chicken]
‘Who is the one that butchered the/a chicken?’
- b. maanu ka [s<n>eeliq/*<m>/*-an/*s- na robo]? [Extraction of the internal argument]
what PIVOT [butcher<PV.PRF>/*AV/*LV/*CV X Robo]
‘What is the thing that Robo butchered?’
- c. inu ka [s<n>eeliq-**an**/*<m>/*-un/*s- na robo Ø rodux]? [Extraction of location]
where PIVOT [butcher<PRF>-LV/*AV/*PV/*CV X Robo Y chicken]
‘Where did Robo butcher the/a chicken?’
- d. ima ka [s-seeliq/*<m>/*-un/*-an na robo Ø rodux]? [Extraction of benefactor]
who PIVOT [CV-butcher/*AV/*PV/*LV X Robo Y chicken]
‘Who did Robo butcher the/a chicken for?’

Having summarized the core traits of Philippine-type voice affixes, I review previous accounts of these affixes in Section 5.3.2.

5.3.2 Previous analyses of Philippine-type voice affixes

The existing accounts of the nature of Philippine-type voice morphology vary in the treatment of (a) *the nature of the voice affixes* and (b) *the functional projection where the affixes are hosted*. In what follows, I summarize and evaluate these analyses.

Existing analyses of the nature of the voice affixes (a) fall into three families. One group of analyses has maintained that voice affixes are the reflexes of *functional heads* (e.g., Guilfoyle, Hung, & Travis 1992; Pearson 2001, 2005; Aldridge 2004 et seq.). The identity of functional heads differs from one analysis to another, which I discuss below. In the following discussion, I refer to this approach as the “functional head” approach.

A second group of proposals has argued that Philippine-type voice affixes are the morphological reflex of an *A’-agree relation* that inflects for the Case status of the goal of the Agree relation (Richards 2000; Rackowski 2002; Rackowski & Richards 2005). I refer to this approach as the “Case agreement” approach.

Yet a third analysis treats these affixes as *extraction morphology*, under the assumption that a Pivot in all Philippine-type languages undergoes A’-movement to [Spec CP] (Erlewine, Levin, & van Urk 2017). I refer to this analysis as the “extraction morphology” approach.

The question in (b) has also received various treatments. Guilfoyle, Hung, & Travis (1992) and Pearson (2001, 2005) have argued that a voice affix is the spell-out of a *Case-licensing head*, ranging from T⁰, to Voice⁰ and Appl⁰. Aldridge (2004 et seq.), however, maintains that voice affixes

are hosted at or below Voice⁰ and function as *transitivity/applicative markers*. Under a series of analyses by Richards (2000), Rackowski (2002), and Rackowski & Richards (2005), these voice affixes are hosted at C, which realizes an A'-agree relation. Finally, according to Erlewine, Levin, and van Urk (2017), Philippine-type voice affixes are *extraction morphology* that track the A'-movement of the Pivot from different structural positions. In this view, then, Philippine-type voice affixes are associated with the presence of C, similar to that assumed in Richards (2000), Rackowski (2002), and Rackowski & Richards (2005).

I provide a brief summary of each of these analyses below.

5.3.2.1 *Guilfoyle, Hung, & Travis (1992)*

In their analysis of Malagasy voice morphology, Guilfoyle, Hung, & Travis (henceforth GHT) (1992) propose that each voice affix is *the spell-out of a specific Case-licensing head*, which forces a corresponding Caseless DP to raise to [Spec IP] to check nominative Case. Under this analysis, in AV clauses, the AV affix *an-* is the reflex of V (i.e., Voice⁰ in the framework of this study), which Case-licenses the Theme in its theta-position. As the Agent remains Caseless, it raises to [Spec IP] to check nominative Case. In a PV clause, the PV affix *-na* is hosted at Infl⁰ and Case-licenses the external argument at [Spec VP] (i.e., [Spec VoiceP] under the Minimalist Program). As the internal argument remains Caseless, it is forced to raise to [Spec IP] for Case-checking. Finally, in CV clauses, the CV circumfix *an- ... -na* is the spell-out of both the Case-licensing heads V⁰ and Infl⁰. As both the external and internal arguments are Case-licensed in-situ, the instrumental DP raises to [Spec IP] to check nominative Case. This analysis is summarized in (39):

(39) *Philippine-type voice morphology: GHT*

- a. “AV”: reflex of V⁰ (Voice⁰)
- b. “PV”: reflex of Infl⁰
- c. “CV”: reflex of V⁰ (Voice⁰) and Infl⁰

As seen above, the composition of Malagasy voices differs from prototypical Philippine-type voice affixes. Therefore, the analysis for Malagasy voice morphology is incompatible with prototypical Philippine-type languages. Further, one of the assumptions of this analysis, that a Pivot occupies the subject position of a clause, is incompatible with more recent observations of Malagasy, which show that Malagasy Pivots behave like A'-elements. See Pearson (2001, 2005) for details.

5.3.2.2 *Pearson (2001, 2005)*

Pearson (2001, 2005) share a core assumption with the analysis in GHT, that Malagasy voice affixes are *the spell-out of functional heads*, while he departs from GHT in proposing that a voice affix realizes the functional head that licenses the A'-trace of an Operator coindexed with the Pivot. This analysis is built on Sportiche's (1992) *Doubly-filled comp filter*, which maintains that a particular

head is spelled out in a clause only if its specifiers contain an A'-trace left by the A'-moved element. For Pearson, then, the nature of the voice affixes is as follows:

(40) *Philippine-type voice morphology: Pearson (2001, 2005)*²⁷

- a. "AV": reflex of Asp_e⁰
- b. "PV": reflex of Asp_r⁰
- c. "CV": reflex of an Appl⁰

5.3.2.3 *Aldridge (2004, 2008, 2011, 2017)*

As discussed in Chapters 2 and 3, Aldridge (2004, 2008, 2011, 2017) has argued that Philippine-type voice affixes are transitivity/applicative markers. Under this analysis, voice affixes are hosted at or below Voice⁰, which indicates the valency of a clause. Aldridge's view of the nature of the voice affixes is summarized in (41):

(41) *Philippine-type voice morphology: Aldridge (2004) et seq.*

- a. "AV": reflex of intransitive Voice⁰
- b. "PV": reflex of transitive Voice⁰
- c. "LV": reflex of High applicative⁰
- d. "CV": reflex of High applicative⁰

It is noteworthy that a similar assumption has also been adopted in a number of descriptive works of Formosan and Philippine languages. A basic assumption shared by these works maintains that the AV affix is an intransitive marker present in intransitive clauses, whereas the PV, LV, and CV affixes are three types of transitive marker used in different types of transitive clauses. See also relevant discussion in Starosta (1995), Ross (2002), Liao (2004), and Teng (2008).

5.3.2.4 *Richards (2000), Rackowski (2002), and Rackowski & Richards (2005)*

While GHT, Pearson (2001, 2005), and Aldridge (2004 et seq.) have all assumed Philippine-type voice affixes to be the spell-out of individual functional heads, Richards (2000), Rackowski (2002) and Rackowski & Richards (2005) argue that Philippine-type voice affixes are the reflex of an A'-agree relation between an A'-head (Topic⁰) and a specific DP in a clause. Specifically, they propose that voice affixes are the morphological reflex of the Agree relation between the topic-probe and that the Pivot specifies *the Case status or the structural position of the Pivot*. Under this analysis, the four

²⁷ Note that Pearson (2001, 2005) assumes that the AV prefix *m-* and the PV affixes *-Vn* and *a-* are realizations of Case-licensing functional heads within TP. When the Op which raises to [Spec WhP] has a nominative case feature to check, the head which checks it is spelled out on the verb as *m-*, and when the Op has an accusative case feature, the head which checks that feature is spelled out as *-Vn* or *a-*. See Pearson (2005:401–5) for details.

voice affixes are the morphological realization of nominative agreement, accusative agreement, dative agreement, and oblique agreement, as in (42a)-(d):

- (42) *Philippine-type voice morphology: Rackowski (2002) and Rackowski & Richards (2005)*
- a. “AV”: reflex of A'-agreement between Topic and the nominative DP
 - b. “PV”: reflex of A'-agreement between Topic and the accusative DP
 - c. “LV”: reflex of A'-agreement between Topic and the dative DP (*licensed by a low Appl head*)
 - d. “CV”: reflex of A'-agreement between Topic and the oblique DP (*licensed by a high Appl head*)

5.3.2.5 Erlewine, Levin, & van Urk (2017)

Erlewine, Levin, & van Urk (henceforth ELV), in their analysis of the Philippine-type voice system, propose that Philippine-type voice affixes are *extraction morphology* that tracks the extraction process of the Pivot. Under this analysis, the extraction morphology is sensitive to the Case status of the Pivot, similar to proposals in Richards (2000), Rackowski (2002), and Rackowski & Richards (2005).²⁸

5.3.2.6 Evaluations

In this subsection, I evaluate the previous analyses of the Philippine-type voice affixes introduced above, and show that none of them can fully account for the empirical mapping between voice-marking and Pivot-selection. Below, I summarize the main claims of these proposals in (43). The basic argument-marking patterns found in six basic constructions shared by Philippine-type languages is summarized in (44).

(43) *TABLE 5.6. Previous approaches to Philippine-type voice affixes*

	GHT (1992)	Pearson (2001)	Aldridge (2004)	Rackowski (2002)	ELV (2017)
a. AV	(tr.) Voice ⁰	Asp _e ⁰	intr. Voice ⁰	Nom-agreement	extraction of DP _{NOM}
b. PV	T ⁰	Asp _r ⁰	tr. Voice ⁰	Acc-agreement	extraction of DP _{ACC}
c. LV	—	—	high Appl ⁰	Dat-agreement	extraction of DP _{DAT}
d. CV	(tr.) Voice ⁰ + T ⁰	Appl ⁰	high Appl ⁰	Obl-agreement	extraction of DP _{OBL}
<i>voice= language</i>	functional head Malagasy	functional head Malagasy	functional head (general)	Agree relation Tagalog	extraction marking (general)

²⁸ Others have proposed that Philippine-type languages are *symmetrical voice languages* (e.g., Foley 2008; Himmelmem 2002, Riesberg 2014; Kuo 2015). These approaches noted that there are four types of transitive patterns, and voice affixes encode the syntactically prominent phrase in each pattern. As these analyses are not articulated under the framework of generative syntax, I do not include them in this section.

(44) TABLE 5.7. *The structural position of the Pivot in some basic constructions*

	AV	PV	LV	CV
a. Transitives	Agent _[Spec VoiceP]	Theme _[V Comp]	Tem/Loc _[PP]	Ben/Inst/Reason ... _[PP]
b. Unergatives	Agent _[Spec VoiceP]	—	Tem/Loc _[PP]	Ben/Inst/Reason ... _[PP]
c. Unaccusatives	Theme _[V Comp]	—	Tem/Loc _[PP]	Ben/Inst/Reason ... _[PP]
d. Statives	Experiencer _[V Comp]	—	—	—
e. Causatives	Causer _[Spec VoiceP]	Causee _{2nd [Spec VoiceP]}	Tem/Loc	Causand _{2nd [V Comp]}
f. Ditransitives	Agent _[Spec VoiceP]	Recipient _[V Comp]	Goal/Source	Theme _[V Comp]

As shown in (44), possible Pivots in both PV- and CV-clauses do not form a homogeneous group both in terms of either their Case status or structural position. In other words, what can serve as the Pivot in PV- and CV-clauses cannot be predicted simply by the Case status or structural position of a phrase. For instance, in productive causatives (44e), both the Causee and the Causand receive accusative Case. However, a Causee can only bear Pivot status when the clause is PV-marked, and a Causand can only bear Pivot status when the clause is CV-marked, despite their shared Case status. This suggests that either a Case-agreement or an Extraction-morphology approach will have difficulties to accounting for the selection of the Pivot in productive causative constructions—as both approaches assume that the morphological distinction of the voice affixes realizes the different Case statuses of the Pivot.

The criterion of Pivot-selection in PV- and CV-clauses is also an issue for the functional-head approach to voice affixes, as possible Pivots in different PV-clauses (44b) and CV-clauses (44d) are licensed by different functional heads and introduced in different structural positions. For instance, possible Pivots in PV clauses include a Theme (in simple transitives), a Causee (in productive causatives), or a Recipient (in ditransitives), whereby the base-generated position of these phrases varies from the internal argument position, the embedded external position, and the specifier of an applicative phrase, respectively.²⁹

I conclude therefore that none of the analyses in (43) is capable of accounting for the selection of the Pivot in PV- and CV-clauses.

5.3.3 Proposal: Philippine-type voice affixes are the spell-out of four different bundles of Agree relations

As concluded in 5.3.2, Pivot-selection in Philippine-type languages does not simply pattern with the Case status or the structural position of the Pivot. Rather, the mapping between voice-marking and the selection of the Pivot in PV- and CV-clauses appears to be sensitive to a number of factors,

²⁹ I have argued in Chapter 4 based on data from Puyuma, Amis, Seediq, and Tagalog that a high applicative analysis of the Locative/Instrument/Benefactor Pivot in LV/CV clauses is difficult to maintain. However, one might argue that these phrases could be licensed as an applied object lower than the internal argument in LV/CV clauses. I remain agnostic about this possibility. Here, my main concern is that it is implausible to assume that the Pivots in CV clauses form a homogeneous group according to either their Case status or structural position.

including (i) Case status of the Pivot, (ii) its grammatical relation, and (iii) the relative structural height of the Pivot with that of other phrases of the same Case status. This is a major challenge to all previous analyses.

I now propose my analysis of the Philippine-type voice morphology. I argue that this seemingly irregular pattern can in fact be captured under a simple analysis if Philippine-type voice affixes are analyzed as four different bundles of Agree relations established with the goal of the topic (δ)-probe, i.e., the Pivot (internal topic). This proposal is illustrated in (45):

- (45) Philippine-type voice affixes are the morphological realization of *four different bundles of the Agree relation(s)* that agree with the topic (the Pivot):
- a. “AV”: the spell-out of the bundle of topic-agreement and φ -agreement
 - b. “PV”: the spell-out of the bundle of topic-agreement and Object-agreement
 - c. “LV”: the spell-out of the bundle of topic-agreement and locative/temporal-agreement
 - d. “CV”: the spell-out of δ -agreement

If this analysis is on the right track, the four sets of voice affixes can be descriptively viewed as *Subject agreement* (“AV”), *Object agreement* (“PV”), *Temporal/locative agreement* (“LV”), and *Simple topic agreement* (“CV”). I discuss the details of this analysis below.

5.3.3.1 Theoretical assumptions

I first outline the theoretical assumptions adopted in the following discussion.

I. Agree and agreement morphology

Following the standard assumption of *Agree* (Chomsky 2000, 2001; Rizzi 1990; Starke 2001) (46), I propose that Philippine-type Austronesian languages employ a topic-feature at C (henceforth the δ -feature). In all finite clauses, the δ -feature will probe down and target the closest phrase in the clause that bears a [topic]-feature—which is morphologically realized as “Pivot”-marking. I will refer to this specific Agree relation between the δ -probe and its goal (i.e., the internal topic) *δ -agreement*. This analysis is illustrated in (47):

- (46) *Agree α can agree with β iff:*
- a. α carries at least one unvalued and uninterpretable feature and β carries a matching interpretable and valued feature.
 - b. α c-commands β .
 - c. β is the closest goal to α , such that β is the closest phrase that bears a matching feature.

- (47) $[C_{[u\delta]} \quad T \quad \dots \quad \text{Internal topic}_{[\delta]}]$ “Pivot”-marking as the reflex of the $[\delta]$ -feature
-

I further propose that Philippine-type voice affixes are the morphological reflex of Agree relation(s) that target the internal topic. Under this analysis, once δ -agreement is established between the probe and the topic, this Agree relation is spelled out as verbal morphology (50):

- (48) *Proposal: Philippine-type voice morphology as the spell-out of topic-agreement*

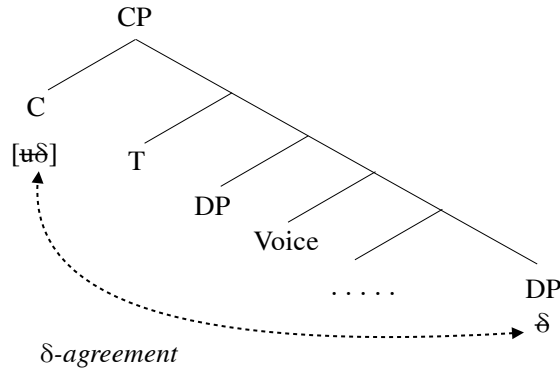

II. Subject-agreement

Following the Uniformity Principle (51) (Chomsky 2001) and the notion of *Strong Uniformity* (52) (Miyagawa 2010, 2017), I assume that abstract ϕ -agreement is present in all human languages—regardless of whether it is morphologically encoded (Chomsky 2000, 2005, 2007, 2008; Pesetsky & Torrego 2006; Preminger 2011).

- (49) *Uniformity Principle*

In the absence of compelling evidence to the contrary, languages are uniform, with variety restricted to easily detectable properties of utterances.

- (50) *Strong Uniformity*

Every language shares the same set of grammatical features, and every language overtly manifests these features.

I assume a particular manifestation of (49)-(50), that all human languages host a ϕ -feature at C/T, and the structurally highest DP will enter into Agree relation with the ϕ -probe, as in (51):³⁰

³⁰ Here and in the diagram in (52), I indicate the locus of the ϕ -probe neutrally as C/T, in the sense of Feature-Inheritance (Chomsky 2007, 2008; Richards 2007).

(51) Assumption: φ -agreement is present in Philippine-type languages

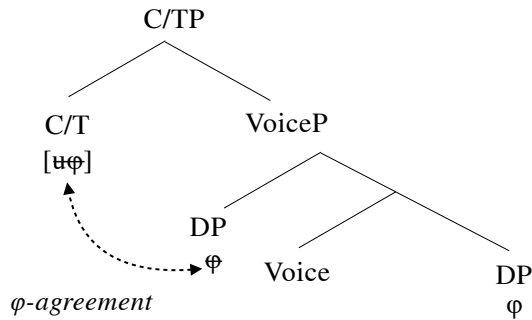

Given the nominative Case analysis of X presented in Chapter 3, I assume that the φ -probe always agrees with the X-marked (nominative) DP in a clause. I will refer to this Agree relation as φ -agreement.

III. Object-agreement

I further assume that abstract *Object-agreement* is present in all human languages, as is φ -agreement with C/T (Chomsky 2000, 2001b; Pesetsky & Torrego 2006; Baker 2012). Under this assumption, transitive Voice⁰ hosts φ -features (henceforth [uF]), as does C/T, which probes the structurally highest DP within VoiceP. This Agree relation is morphologically manifested in some languages as *Object-agreement*, as in (52):³¹

(52) Assumption: *Object-agreement* is present in Philippine-type languages

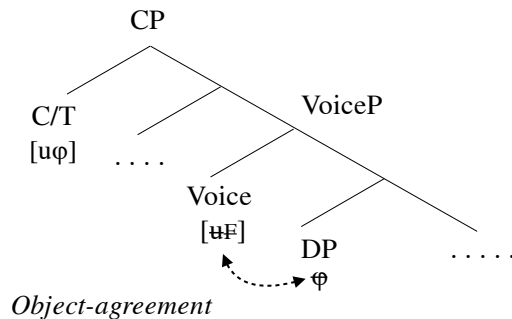

Recent observations from Amharic provide novel empirical support for this assumption. Amharic is a Semitic language that employs both accusative Case and Object-agreement. According to Baker (2012), Object-agreement in the language is (i) subject to locality (restricted to the highest DP in the matrix VoiceP), (ii) unique per clause, (iii) insensitive to case, and (iv) sensitive to phase-

³¹ Here, “Voice” corresponds to *v* in Chomsky (2001, 2002).

like conditions and cannot agree with PPs. As Baker concludes, Amharic Object-agreement is the realization of an abstract Agree relation with [uF] at transitive v (Voice).

Evidence for this claim is summarized as follows. First, in Amharic, a definite direct object in transitive clauses shows obligatorily agreement with the verb, as in (53):

(53) *Object agreement in Amharic transitives*

l\$mma w&&a-w-ŋn j-aj-əw-al.
 Lemma dog-DF-ACC 3MASC.S-see-3MASC.O-AUX
 ‘Lemma sees the dog.’ (Baker 2012:257)

Importantly, when it comes to double-object ditransitives, Object-agreement can only target the *Recipient* and not the Theme, although both arguments bear accusative case. This is seen in the sentence in (54) below, in which the verb shows Object-agreement with the third-person feminine Recipient ‘Aster’, and cannot agree with the masculine Theme ‘the baby’:

(54) *Object agreement with the Recipient in Amharic double-object constructions*

l\$mma aster-in h's'an-u-n asaj-at/*asaj-\$-w.
 Lemma Aster-ACC baby-DF-ACC show-(3MASC.S)-3FEM.O/*show-3MASC.S-3MASC.O
 ‘Lemma showed Aster the baby.’ (Baker 2012:258)

A similar observation obtains with Amharic causatives (Amberber 2002:46-47; Duncan & Aberra 2009). As seen below, only the Causee and not the Causand can trigger Object-agreement with the verb:

(55) *Object agreement with the Causee in Amharic productive causatives*

aster was-a-n as-meta-ŋ(-ññ.
 Aster ball-DF-ACC CAU-hit-3FEM.S-1SG.O
 ‘Aster made me kick the ball.’ (Duncan & Aberra 2009)

As the data above indicates, Amharic Object-agreement does not simply target accusative DPs, but is sensitive to locality. This is confirmed with the data in (56), which shows that in prepositional dative constructions, Object-agreement with the Theme becomes available, since the Recipient is introduced as a PP and is no longer an intervener between the feature F on Voice⁰ and the internal argument. Therefore, Object-agreement targets the Theme:

(56) *Object agreement with the Theme in Amharic prepositional datives*

ŋd)-u-n w\$d\$almaz lak-hw-ət.
 child-DF-ACC to Almaz send-1SG.S-3MASC.O
 ‘I sent the child to Almaz.’ (Baker 2012:262)

Finally, the example in (57) shows that Object-agreement in Amharic is insensitive to the case status of a DP, as it can target a dative-marked DP within the VoiceP:

(57) *Object agreement with the Theme in Amharic prepositional datives*

l\$mma **l-aster** tarik-u-n n\$gg\$r-at/*n\$gg\$r-\$-w.
 Lemma **DAT-Aster** story-DF-ACC tell-(3MASC.S)-**3FEM.O**/*show-3MASC.S-**3MASC.O**
 ‘Lemma told *Aster* the story/his story.’ (Baker 2012:261)

Given the observations above, Baker concludes that Amharic Object-agreement is the reflex of an Agree relation between *v* (Voice) and the highest DP within *v*P (VoiceP), which follows from Chomsky’s (2000, 2001) proposal. In Section 5.3.3.3, I will argue that the selection of the Pivot in Philippine-type PV-clauses shows a pattern strikingly similar to Amharic Object-agreement.

IV. *Agree relations may bundle in their morphological output*

Finally, I assume that different Agree relations may bundle in their morphological output when more than one Agree relation targets the same goal (see, e.g., Bejar 2003; Coon & Bale 2014; van Urk 2015; Baier 2017). A well-known example of this is the *Anti-Agreement Effect* (Ouhalla 1993, 2005; Ouali 2008; Baker 2008; Gerds 1980; Chung 1998; Richards 1997), whereby the morphological output of ϕ -agreement is deficient when the goal is also in Agree relation with an A’-probe.

Building on these assumptions, I present my account for each of the four Philippine-type voice affixes in 5.3.3.2–5.

5.3.3.2 *The nature of “AV”-morphology*

Recall that in Chapter 2, I concluded that the presence of the AV affix correlates with the placement of Pivot status on phrases that can be characterized as *subjects* in nominative-accusative languages. This is summarized in (58):

(58) *The mapping between AV-morphology and Pivot-selection*

- | | |
|--|--|
| a. Transitives/unergatives: the external argument | } regardless of the presence or absence of a
locative/temporal/benefactive phrase |
| b. Unaccusatives: the internal argument | |
| c. Productive causatives: the Causer (highest external argument) | |
| d. Ditransitives: the Agent (highest external argument) | |

Given (58), I argue for the following analysis of “AV”-morphology:

- b. m<n>huqil **ka pawan.** [unaccusative]
 av-<PRF>die **PIVOT Pawan**
 ‘Pawan passed away.’
- c. m-bserux **ka pawan.** [stative]
 av-lazy **PIVOT Pawan**
 ‘Pawan is lazy.’
- d. m<n>ekan Ø sari **ka pawan.** [transitive]
 av<PRF>eat Y taro **PIVOT Pawan**
 ‘Pawan ate taro.’

5.3.3.3 *The nature of “PV”-morphology*

I now turn to the analysis of “PV”-morphology, whose mapping with Pivot-selection is summarized in (62):

(62) *Pivot-selection in types of PV clauses*

- a. Transitive clauses: internal argument
- b. Productive causatives: Causer (the highest DP within VoiceP)
- c. Ditransitives: Recipient (the highest DP within VoiceP)

Given (62), I argue for the following analysis of “PV”-morphology:

(63) A Philippine-type PV affix is the spell-out of the bundle of *topic-agreement* (δ -*agreement*) and *Object-agreement*.

Pivot-selection in Philippine-type PV-clauses shares a number of similarities with the selection of the trigger of Amharic Object-agreement (see Section 5.3.3.1). First, in both cases, the selection of the Pivot/trigger is not simply tied to the Case status (accusative) or the structural position of a DP, but is sensitive to the relative structural height of the Pivot/trigger compared to other DPs in the clause.

Several important observations motivating this statement come from productive causatives and ditransitives in both languages. First, only the structurally highest accusative DP can trigger the agreement. Second, similar to Amharic Object-agreement, PPs in Philippine-type languages do not trigger “PV”-agreement. While an accusative-marked Recipient or Causee can block “PV”-agreement with the internal argument, the presence of a locative, instrumental, or benefactive phrase does not prevent an internal argument from being a Pivot in a PV-clause. This is seen in the data below from Puyuma and Tagalog:

(64) *The absence of intervening effects in PV-clauses with an adjunct*

- a. ku=deru-aw **na** **patraka** (i sawka/kana daderuwan). [Puyuma]
 1SG.X=cook-PV **DF.PIVOT meat** (LOC kitchen/DF.Y pot)
 ‘I cooked meat (in the kitchen/with the pot).
- b. ni-luto ni ivan **ang adobo** (sa kawali/sa pamamagitan ng kaldero). [Tagalog]
 PV.PRF-cook PN.X Ivan **PIVOT adobo** (DF.Y pan /DF.Y P LK metal.pot)
 ‘Ivan cooked adobo (in the pan/with a metal pot).

Given its distributional parallelism with Amharic Object-agreement, I argue that “PV”-morphology in Philippine-type languages is best analyzed as the spell-out of the bundle of topic-agreement (δ -agreement) and *Object-agreement*. Under this analysis, when the structurally highest DP within the highest VoiceP in a CP bears a [topic]-feature, “PV”-agreement will appear on the verb, as in (65):³³

(65) *Proposal: the Agree relation in PV-marked simple clauses*

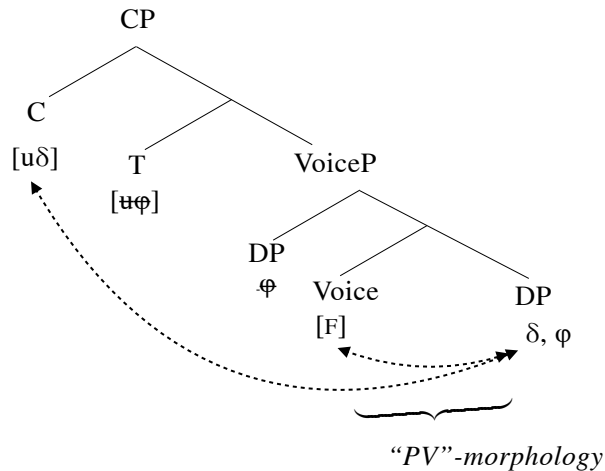

Under this analysis, when a Causee in productive causative bears a [topic]-feature, “PV”-agreement will appear on the verb, as it is the target of both δ -agreement and *Object-agreement*. This is illustrated in (66):

³³ A potential question for this analysis concerns how abstract Object-agreement and Subject-agreement are both ϕ -agreement in nature (Chomsky 2001b; Pesetsky & Torrego 2006; Baker 2012), and yet the two abstract Agree relations are necessarily assumed to be spelled out differently in their morphological output. Namely, the bundle of *Subject-agreement* (i.e., the Agree relation between [u ϕ] on C/T and its goal) and *topic-agreement* is spelled out as “AV”, and that of *Object-agreement* (i.e., the Agree relation between [u ϕ] on Voice⁰ and its goal) and *topic-agreement* is spelled out as “PV”. I argue that this assumption is not too far-fetched, as languages with both overt Subject- and Object-agreements are known to employ different morphological forms for each. See, for example, Baker (2012) for a description of Amharic (Semitic) and Payne & Dew 1970[2009] for that of Kamano.

(66) *Proposal: the Agree relation in PV-marked causatives*

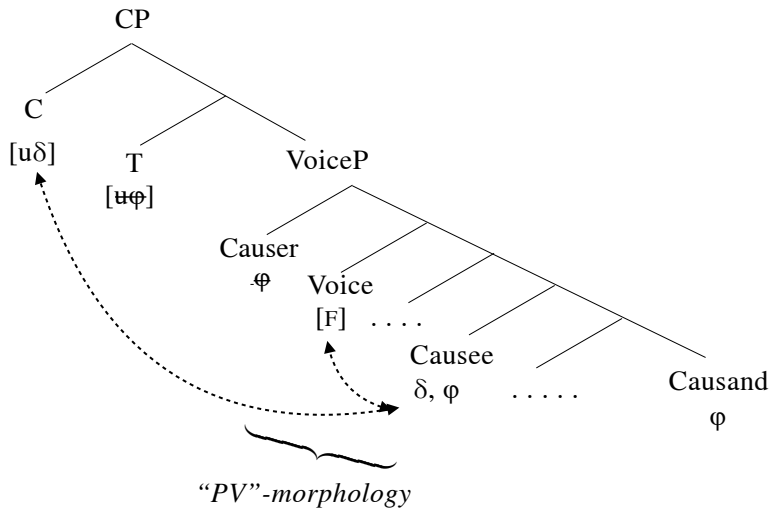

Similarly, in ditransitives, when the Recipient bears a [topic]-feature, “PV”-morphology will appear on the verb, as the Recipient is the structurally highest DP within the VoiceP, hence the trigger of Object-agreement. Therefore, the bundle of topic-agreement (δ -agreement) and Object-agreement is spelled out as “PV”-morphology (67):

(67) *Proposal: the Agree relation in PV-marked ditransitives*

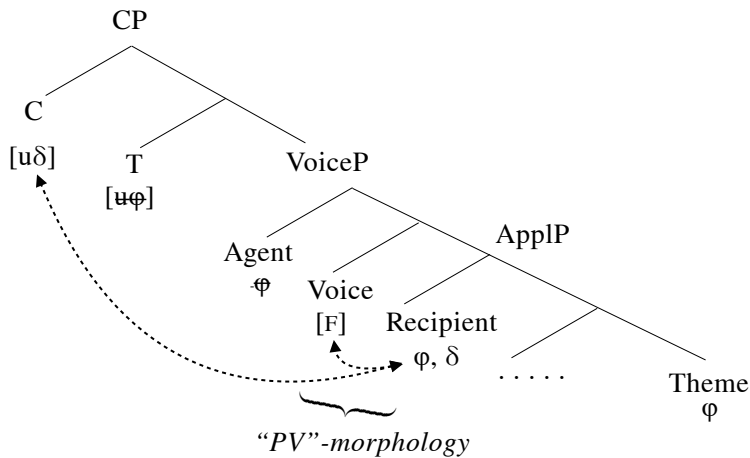

5.3.3.4 “LV”-morphology as temporal/locative agreement

I now turn to the analysis of “LV”-morphology, whose mapping with Pivot-selection is summarized in (68):

(68) *Pivot-selection in types of LV-clauses*

- a. Transitives/unergatives/unaccusatives: Temporal/locative phrases, Goal, Source
- b. Ditransitive: Goal/Source
- c. Productive causatives: Locative

I argue that LV-morphology is best analyzed as (69):

(69) A LV affix is the spell-out of the bundle of *topic-agreement* (δ -*agreement*) and *Temporal/locative-agreement*.

Support for this proposal comes from three characteristics of Philippine-type languages. First, the marker **i*, which marks the Pivot in LV-clauses across the majority of Austronesian primary branches, can be traced back to Proto-Austronesian as a generic preposition for location in space or time (Blust 2009, 2015; the Austronesian Comparative Dictionary).³⁴

This reconstruction is built on evidence from languages including Seediq, Puyuma, Amis, Ifugao (Malayo-Polynesian), Nggela, Lau, ‘*re’+re, Proto-Micronesian, Samoan, Rennellese, and Hawaiian. Across these languages, the preposition *i* consistently marks temporal/spatial phrases and not other types of adjuncts, such as instruments or benefactors. This suggests that temporal and locative phrases in Philippine-type languages are licensed by a specific type of preposition.

The Formosan language Paiwan provides additional empirical support for this proposal. In Paiwan, when a locative/temporal phrase is Pivot-marked, the Pivot-marker and the preposition *i* can optionally co-occur (Chang 2006), as seen in (70a). This optionality does not apply to any other case markers, which never co-occur with “Pivot”-marking, suggesting that the temporal/locative marker *i* is indeed different from what I analyzed as case markers. Additional support for this claim comes from Ferrell (1979), who reports that the marker *i* can optionally co-occur with the case marker Y in non-LV clauses, when a locative phrase is not Pivot-marked (70b). Importantly, this preposition is never observed with other types of “non-core” phrases such as instruments or benefactors.

(70) *Paiwan: “Pivot”-marker cooccurring with the locative preposition*

- a. p<in>a-pana’-an a icu a i maza ni palang tay kui ta zua venan.
CAU<PRF>-shoot.arrows-LV PIVOT this LK LOC here PN.X Palang OBL Kui Y that deer
‘Palang told Kui to shoot that deer (with arrow) here.’ (A. Chang 2006:195)
- b. q<m>alup a caucau tua vavuy {i /i tua} gadu tua vuluq.
hunt<AV> pivot man Y boar {LOC/LOC Y} mountain Y spear
‘The man hunts wild pigs in the mountains with a spear.’ (Ferrell 1979:202)

³⁴ As seen in (a)-(b), in many Philippine-type languages, both locative and temporal phrases can be selected as the Pivot in an LV clause:

- (a) h<n>uqil-an na walis ka kusun/paran. [Seediq]
die<PRF>-LV X Walis PIVOT yesterday/Paran
‘Walis passed away yesterday/at Paran.’
- (b) ka-hufut-an ni kulas ku inacila/kalingku. [Amis]
KA-born-LV X Kulas PIVOT yesterday/Kalingku
‘Kulas was born yesterday/at Kalingku.’

The observations above support the current proposal that *i* is a preposition that assigns inherent Case to its complement, with this inherent Case morphologically realized as Y-marking.³⁵

Given the observations above, I propose that the preposition *i* assigns a specific inherent Case to temporal locative phrases (henceforth temporal/locative-agreement (γ -agreement)). I argue accordingly that an LV affix is best analyzed as the bundle of topic-agreement (δ -agreement) and temporal/locative-agreement (γ -agreement).³⁶ Under this analysis, the Agree relations in an LV-clause are as indicated in (71):³⁷

(71) *LV clauses with a temporal/locative phrase as the Pivot*

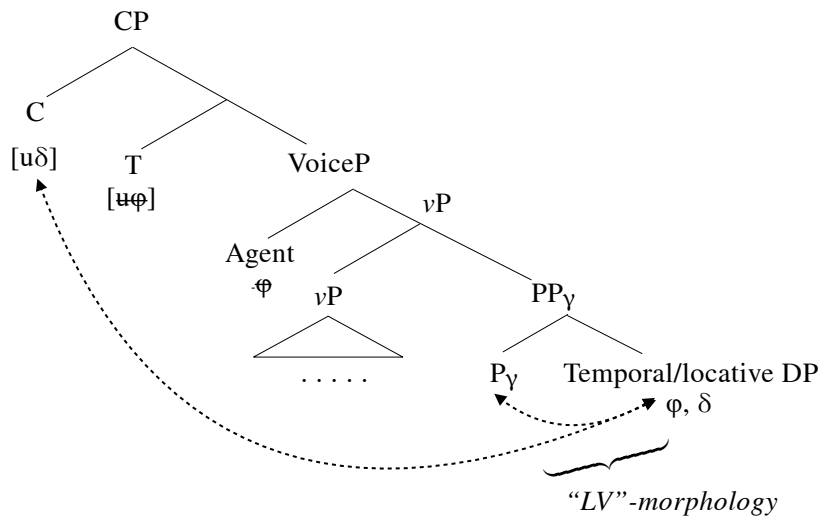

³⁵ In this case, Philippine-type languages are similar to English in employing the same morphological marking/inflection for structural accusative Case and an inherent Case assigned by a preposition head (i.e., ‘John loves *her* vs. John gave the letter to *her*.)’

³⁶ It is important to note that the analysis above excludes instances from innovative languages, where in some verbs of PV function take an LV affix. As PV/LV syncretism (see Blust & Chen 2017 for details) is a phenomenon commonly observed in Philippine-type languages and can be considered an innovation, I do not include such patterns in the present proposal of the prototypical function of Philippine-type voice affixes.

³⁷ A specific question about LV-marked ditransitives concerns an observation from a number of Philippine-type languages, that typical ditransitive verbs such as ‘give’, ‘send’, and ‘mail’ can take either a PV or LV affix, both of which have the Recipient Pivot-marked, as in (a)-(b):

- (a) pafeli-**en** aku **ku** wawa tu paysu. [Amis]
 give-PV 1SG.X **PIVOT child** Y money
 ‘I will give the child money.’
- (b) pafeli-**an** aku **ku** wawa tu paysu.
 give-LV 1SG.X **PIVOT child** Y money
 ‘I gave the child money.’

This phenomenon can be viewed in two different ways. The first is to assume it to be the outcome of the functional merger of PV- and LV-forms as an innovation. A second way to understand it is by assuming that an LV-marked ditransitive is structurally different from PV-ditransitives in that the Recipient/Goal is expressed via a PP. As the notion of Goal in many languages is similar to that of locative, we may assume that the Pivot-marked goal is structurally a locative phrase targeted by ϕ -agreement.

5.3.3.5 “CV”-morphology indicates a lack of an Agree relation other than δ -agreement

Finally, I turn to my analysis of the CV affix. As discussed in 5.3.2, possible Pivots in CV clauses vary in their structural position and case status. This is summarized in (72):

(72) Possible Pivots in types of CV-clauses

- a. Simple clauses: Instrument, Benefactor, Reason, Cause, Stimulus, Purpose, Manner, Degree
- b. Ditransitive: Theme
- c. Productive causatives: Causand

I argue that this seemingly unselective pattern can be captured under the analysis in (74):

(73) A Philippine-type CV affix is the spell-out of *topic-agreement* (δ -agreement).

Under this proposal, the CV-morphology is present when the goal of the δ -probe is not under Agree relation with any other probe. This explains (i) why possible Pivots in CV-clauses do not form a homogenous groups either in case status or structural position, as well as (ii) why these phrases are either adjuncts or DPs that are structurally low. This analysis is illustrated in the tree diagrams below, which present the Agree relation of the topic in simple transitive clauses (74), causatives (75), and ditransitives (76):

(74) Proposal: the Agree relation in CV-marked simple clauses

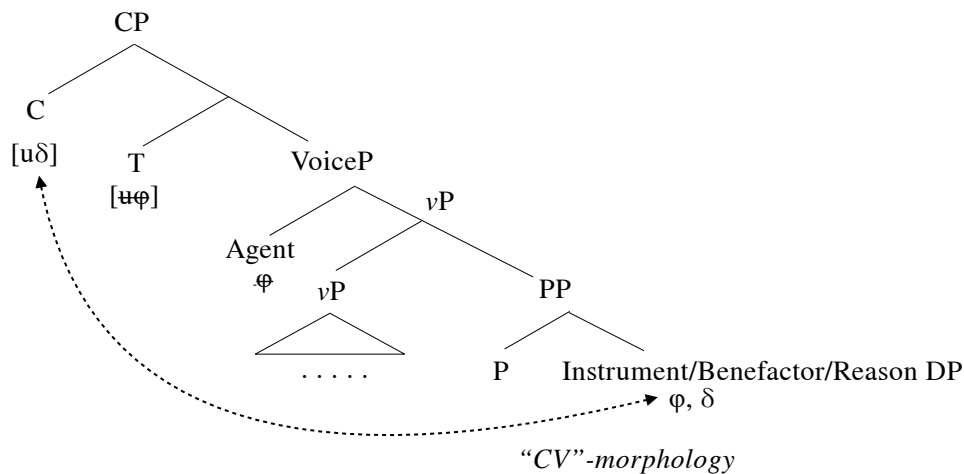

In productive causatives, a Causand does not trigger Object-agreement, as it is structurally lower than the Causee—which is the highest argument within the matrix VoiceP. Therefore, when the Causand bears a [topic]-feature, the simple δ -agreement is spelled out as “CV”-agreement (75):

(75) *Proposal: the Agree relation in CV-marked causatives*

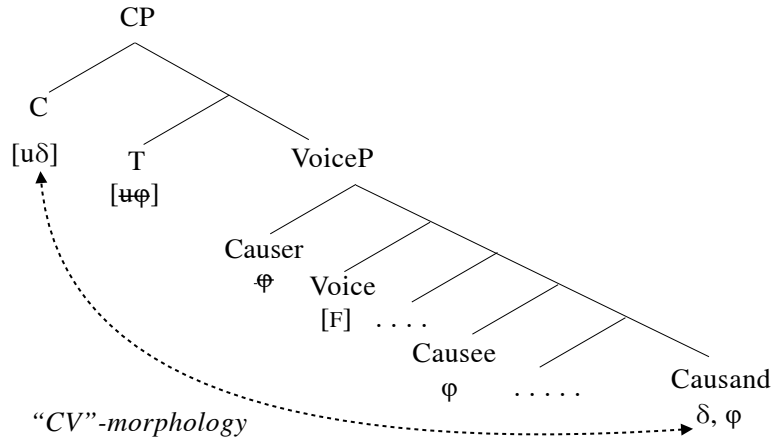

Similarly, in ditransitives (76), the Theme argument, which is structurally low, is not under Agree relation with the feature F on Voice. Therefore, when it bears a [topic]feature and enters into Agree relation with the δ -probe, δ -agreement is spelled out as “CV”-morphology (i.e., Simple topic-agreement):

(76) *Proposal: the Agree relation in CV-marked ditransitives*

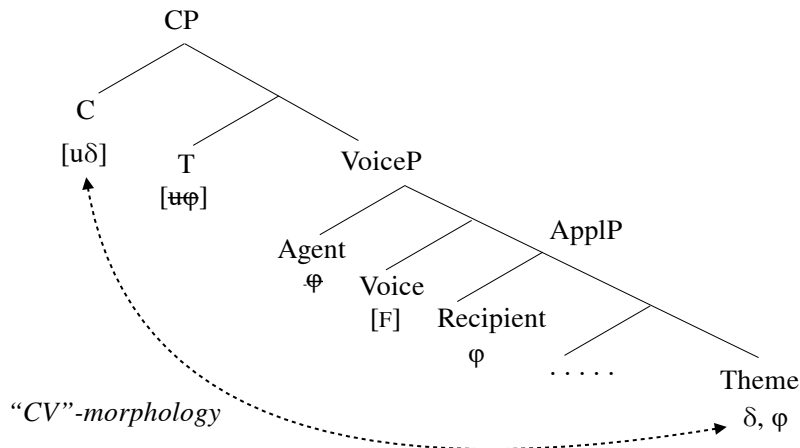

In brief, under the current analysis, the last-resort-like function of the CV affix in terms of Pivot-selection is accounted for by an analysis in which the goal in such clauses lacks an Agree relation other than topic-agreement (δ -agreement). In this view, the fact that possible Pivots in CV clauses vary from DPs that are structurally low to adjunct PPs is straightforwardly accounted for.

5.4 Evidence for voice affixes as agreement morphology

I have argued in Section 5.3 that Philippine-type voice affixes are best analyzed as the spell-out of different bundles of Agree relations with the topic in a clause. In this section, I discuss supporting evidence for this analysis.

5.4.1 Evidence from Pivot placement in productive causatives with multiple embedded VoicePs

A major difference between the current analysis and previous proposals lies in the treatment of the Philippine-type CV affix. All existing analyses assume it to be associated with the presence of an applicative head (see Section 5.3.2 and Chapter 4). Under the present analysis, however, a CV affix simply indicates the presence of simple topic-agreement (with a lack of another type of Agree relation associated with the topic of the clause). In this subsection, I discuss another construction that lends direct support for this analysis.

Recall that in Chapter 4, we concluded that productive causatives in Puyuma, Amis, Seediq, and Tagalog employ a bi-clausal structure regardless of voice type. Combining this conclusion with the analysis of “Pivot”-marking proposed in Section 5.2, the argument-marking mechanism in causative constructions is illustrated in (77), wherein “Pivot” is a topic-marker that overrides morphological case:

(77) *TABLE 5.8. The mapping between argument-marking and voice-marking in Philippine-type languages*

	a. AV		b. PV		c. CV
Causer	Nominative	Topic	Nominative		Nominative
Causee	Accusative		Accusative	Topic	Accusative
Causand	Accusative		Accusative		Accusative Topic

As seen above, in productive causative constructions, when Pivot-marking falls on the Causer, Causee, and Causand, the cooccurring voice marker on the verb is in AV, PV, or CV, respectively. This is illustrated in (78)-(80):

(78) *Pivot-placement in productive causatives: Puyuma*

- a. Ø-pa-tenun=**ku** kan kuatur dra katring. [AV]
 AV-CAU-weave=**ISG.PIVOT** SG.Y Kuatur ID.Y pants
 ‘I made Kuatur weave pants.’
- b. ku=pa-tenun-**aw** **i** **kuatur** dra katring. [PV]
 ISG.X=CAU-weave-PV **SG.PIVOT** **Kuatur** ID.Y pants
 ‘I made Kuatur weave pants.’

- c. ku=pa-tenun-**anay** kan kuatur **na** **katring**. [CV]
 1SG.X=CAU-weave-CV SG.Y Kuatur **DF.PIVOT pants**
 ‘I made Kuatur weaving *pants*.’

(79) *Pivot-placement in productive causatives: Amis*

- a. Ø-pa-pi-tenuwuy **kaku** ci-Panay-an mi-tenuy t-una liqu’. [AV]
 AV-CAU-PI-weave **1SG.PIVOT** PN-Panay-Y AV-weave Y-that clothes
 ‘I made Panay weave clothes.’
- b. pa-pi-tenuwuy-**en** aku **ci-panay** t-una liqu’. [PV]
 CAU-pi-try-**PV** 1SG.X **PN.PIVOT-Panay** Y-that clothes
 ‘I make *Panay* weave clothes.’
- c. **sa**-pa-pi-tenuwuy aku ci-Panay-an **k-una** **liqu’**. [CV]
 CV-CAU-PI-weave 1SG.X PN-Panay-Y **PIVOT-that clothes**
 ‘I made Panay weave *clothes*.’

(80) *Pivot-placement in productive causatives: Seediq*

- a. Ø-p-imah=**ku** Ø iwan Ø sino. [AV]
 AV-CAU-drink=**1SG.PIVOT** Y Iwan Y alcohol
 ‘I made Iwan drink alcohol.’
- b. p-imah-**un**=mu Ø sino **ka iwan**. [PV]
 CAU-drink-**PV**=1SG.X Y alcohol **PIVOT Iwan**
 ‘I will make *Iwan* drink alcohol.’
- c. s-p-imah=mu Ø iwan **ka sino**. [CV]
 CV-CAU-drink=1SG.X Y Iwan **PIVOT alcohol**
 ‘I made Iwan drink *alcohol*.’

Importantly, the mapping between voice-marking and Pivot-selection in these languages is unaffected by the presence of an additional embedded VoiceP. This is seen in (81)-(83):

(81) *Pivot-placement in multiple embedded clauses: Puyuma*

- a. Ø-pa-talam=**ku** [tenun kan kuatur dra katring]. [AV]
 AV-CAU-try=**1SG.PIVOT** [weave<AV> SG.Y Kuatur ID.Y pants]
 ‘I made Kuatur try weaving pants.’
- b. ku=pa-talam-**aw** [tenun **i** **kuatur** dra katring]. [PV]
 1SG.X=CAU-try-**PV** [weave<AV> **SG.PIVOT Kuatur** ID.Y pants]
 ‘I made *Kuatur* try weaving pants.’
- c. ku=pa-talam-**anay** [tenun kan kuatur **na** **katring**]. [CV]
 1SG.X=CAU-try-**CV** [weave<AV> SG.Y Kuatur **DF.PIVOT pants**]
 ‘I made *Kuatur* try weaving *pants*.’

(82) *Pivot-placement in multiple embedded clauses: Amis*

- a. Ø-pa-pi-tanam **kaku** [ci-Panay-an mi-tenuy t-una liqu’]. [AV]

AV-CAU-PI-try **1SG.PIVOT** [PN-Panay-Y AV-weave Y-that clothes]
 ‘I made Panay try weaving clothes.’

- b. pa-pi-tanam-**en** aku [**ci-Panay** mi-tenuy t-una liqu’]. [PV]
 CAU-pi-try-**PV** 1SG.X [**PN.PIVOT-Panay** AV-weave Y-that clothes]
 ‘I make *Panay* try weaving clothes.’
- c. sa-pa-pi-tanam aku [ci-Panay-an mi-tenuy **k-una liqu’**]. [CV]
 CV-CAU-pi-try 1SG.X [PN-Panay-Y AV-weave **PIVOT-that clothes**]
 ‘I made Panay try weaving *clothes*.’

(83) *Pivot-placement in multiple embedded clauses: Seediq*

- a. Ø-p-ququ=**ku** Ø iwan [p-imah Ø sino]. [AV]
 AV-CAU-try=**1SG.PIVOT** Y Iwan [AV.EMD-drink Y alcohol]
 ‘I made Iwan try drinking alcohol.’
- b. p-ququ-**un**=mu [p-imah Ø sino **ka iwan**]. [PV]
 CAU-try-**PV**=1SG.X [AV.EMD-drink Y alcohol **PIVOT Iwan**]
 ‘I will make *Iwan* try drinking alcohol.’
- c. s-p-ququ=mu [Ø iwan p-imah **ka sino**]. [CV]
 CV-CAU-try-**PV**=1SG.X [Y Iwan AV.EMD-drink **PIVOT alcohol**]
 ‘I made Iwan try drinking *alcohol*.’

In the data above (81)-(83), the causative constructions embed an additional layer of verb phrase introduced by the verb ‘try’. Importantly, the presence or absence of this additional level of embedding has no effect on Pivot-selection. When the sentence is marked in AV, PV, or CV, “Pivot”-marking falls on the *Causer*, *Causee*, or *Causand*, respectively, as it does in the constructions in (78)-(80). In other words, the presence of the additionally embedded verb phrase “try X” does not affect the licensing of the Pivots and their corresponding voice marker. When the causative sentence is CV-marked, “Pivot”-marking falls on the Causand ((81c), (82c), (83c)), regardless of how deeply embedded it is:

- (84) a. C T Causer Voice v_{cause} [Causee Voice v V Causand]
 [X = NOM] [Y = ACC] ⚡ “Pivot”-marked
- b. C T Causer Voice v_{cause} [Causee_i Voice v V_{try} [pro_i Voice v V Causand]]
 [X = NOM] [Y = ACC] ⚡ “Pivot”-marked

This invariable mapping pattern between Pivot-selection and voice-marking follows directly from the present account of the nature of the Philippine-type CV affix: as the topic phrase (*Causand*) in both (84a) and (84b) is neither the subject nor direct object of the clause nor a locative/temporal phrase, it is predicted to bear only topic-agreement (δ -agreement) with the topic-probe. According to the analysis presented in Section 5.3, bare topic-agreement (δ -agreement) is spelled out as “CV”-

morphology. This analysis correctly predicts that the structural depth of a Causand has no effect on Pivot-selection.

In contrast, the fact that “Pivot”-marking can fall on the Causand in (84b) is problematic for the high-applicative approach to the CV affix (Pearson 2001; Rackowski 2002; Aldridge 2004 et seq.) (see Section 5.3.2 for details), as it is implausible to assume the Causand to be licensed as an applied object of the matrix verb ‘try’.

5.4.2 Evidence from the voice-marking restriction on non-main verbs within a CP

Recall that in Section 5.3.1, we discussed the morphological constraint (85) observed in conservative Philippine-type languages:

- (85) Within a CP, all non-main verbs show a voice-marking restriction, as the “true” agreement is spelled out on the main verb.

Consider the following data from Puyuma (86) and Isbukun Bunun (87):

(86) *The “AV-only” constraint on non-highest lexical verb within a CP: Puyuma*

- a. talem i senten sabana/*-aw kan sawagu.
 <AV>try SG.PIVOT Senten <AV>cheat/*PV/*LV/*CV SG.Y Sawagu
 ‘Senten tried to cheat Sawagu.’
- b. tu=talam-aw kan senten sabana/*-aw i sawagu.
 3S.X=try-PV SG.X Senten <AV>cheat/*PV SG.PIVOT Sawagu
 ‘Senten tried to cheat Sawagu.’

(87) *The “voice concord” constraint on non-highest lexical verb within a CP: Isbukun Bunun*

- a. Ø-tanam dahu tu ma-pazikpik/*-un suu.
 AV-try Dahu.PIVOT Y AV-cheat/*PV 2SG.Y
 ‘Dahu tried to cheat you.’
- b. tanem-un=as dahu tu pazikpik-un/*ma-
 try-PV=2SG.PIVOT Dahu LK cheat-PV/*AV
 ‘Dahu tried to cheat you.’ (Wu 2013:76)

Both (86) and (87) contain an infinitive that involves the same transitive verb ‘cheat’ embedded under a matrix verb ‘try’. In Puyuma (86), the embedded verb ‘cheat’ is obligatorily AV-marked, regardless of the voice-marking of the matrix verb. In Isbukun Bunun, however, the voice-marking of the same verb ‘cheat’ must agree with that of the matrix verb ‘try’. According to previous analyses of these two languages (Wu 2013; Chen & Fukuda 2015), there is no evidence suggesting a difference in the size of the embedded infinitives between Puyuma and Isbukun Bunun. In both

languages, the infinitives are compatible with (i) embedded negators and (ii) agent-oriented adverbials. The same observation is obtained with similar constructions in Amis and Seediq, as seen in the following examples (88a)-(b):

(88) *The compatibility of agent-oriented adverbs and negation with embedded infinitives*

- a. ku=talam-ay [(adri) taranapaw salem/*-ay na ladru]. [Puyuma]
 1SG.X=try-LV[PV] [(NEG) carefully<AV> grow<AV>/*LV[PV] DF.PIVOT mango]
 ‘I tried (not) to grow the mango (carefully).’
- b. tanam-en aku [ca’ay padeteng pi-keter/*-en ku wawa aku]. [Amis]
 try-PV 1SG.X [NEG deliberately AV.EMD-scold/*-PV PIVOT child 1SG.POSS]
 ‘I tried not to scold my child deliberately.’
- c. spung-un=mu [adi qlahang m-qeriq/*-enka tederuy]. [Trk. Seediq]
 try-PV=1SG.X [NEG carefully<AV> AV-drive/*PV PIVOT car]
 ‘I will try not to drive the car carefully.’

I argue that these morphological constraints on the voice morphology of non-main verbs follow from the present analysis of Philippine-type voice affixes, while they remain a problem for previous analyses. Given that (i) δ -agreement is unique per CP and (ii) every lexical verb in these languages must carry a voice affix, we expect Philippine-type languages to employ certain strategies for the spell-out of the voice-marking on non-highest lexical verbs within a CP. Following Chung (2004), I assume that the choice between the “AV-only” constraint and the “voice-concord” constraint is postsyntactic, meaning it is a language-specific design to satisfy the rule in (ii). Interestingly, within three Austronesian primary branches (Tsouic, Bunun, and Malayo-Polynesian), both the “AV-only” and “voice-concord” strategies are attested in different languages. This tentatively supports my current proposal that these two constraints are two (postsyntactic) morphological manifestations of the same syntactic constraint.^{38,39}

5.5 Conclusion: What makes a Philippine-type voice system?

In this section, I sum up the analyses presented so far in Chapters 2–5.5, and discuss how Philippine-type Austronesian languages fit into a syntactic typology of languages under the current analysis.

³⁸ Note that in the Formosan literature, embedded infinitives selected by a *try*-type verb or aspectual verbs are commonly analyzed as restructuring infinitives (e.g., T. Chen 2010; Chang 2014; Wurmbrand 2014; V. Chen & Fukuda 2016). See Chapter 2 for a relevant discussion. Under this line of analysis, the AV-only or Voice-concord constraint is associated with the deficient size of a restructuring infinitive. However, given the analysis to be presented in this chapter, I will argue that the AV-only constraint is better viewed as default agreement.

³⁹ A remaining question is how the mood-sensitive nature of Philippine-type voice morphology can be incorporated into the present analysis. As both topic and mood are discourse-configurational features, the fact that the topic-indicating morphology inflects for mood is not surprising. I propose that mood inflection in Philippine-type voice affixes can be captured under the analysis that the δ -feature in Philippine-type languages is hosted at Mood. Therefore, the morphological output of the verbal morphology is also sensitive to mood.

5.5.1 The design of the Philippine-type voice system

Under the present analysis, Philippine-type languages exhibit a nominative-accusative case system. Nominative Case is realized by the morphological marker X, and accusative Case by the marker Y.⁴⁰ Given the analyses presented in Chapters 2–3, the source of nominative and accusative Case is (finite) T and Voice⁰, respectively. This proposal is illustrated in (89):

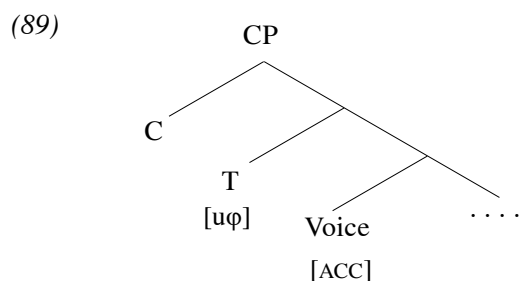

Under the analyses presented in Section 5.2, “Pivot”-marking in Philippine-type languages is a topic-marker that overrides morphological case. Namely, when a phrase is the topic, it carries “Pivot”-marking, and its morphological case is not visible. Under this analysis, the argument-marking pattern of Philippine-type languages is analyzed as in (90):

(90) TABLE 5.9. Proposal: the nature of the Philippine-type argument-marking pattern

	(a) AV	(b) PV	(c) LV	(d) CV
External argument	Nominative Topic	Nominative	Nominative	Nominative
Internal argument	(Accusative)	Accusative Topic	(Accusative)	(Accusative)
Location	(Locative)	(Locative)	Locative Topic	(Locative)
Instrument/benefactor	(Oblique)	(Oblique)	(Oblique)	Oblique Topic

The table above suggests that Philippine-type voice affixes are *topic-indicating* morphology that cross-reference the selection of the topic in a clause. I have proposed that a topic must enter into Agree relation with the topic (δ)-probe, and that Philippine-type voice morphology is the spell-out of the Agree relation(s) that target the topic of a clause.

Under this proposal, when the subject of the clause carries a [topic]-feature, the bundle of topic-agreement (δ -agreement) and subject-agreement (ϕ -agreement) is spelled out as “AV”-morphology. When the direct object of a clause carries a [topic]-feature, the bundle of δ -agreement and Object-agreement is spelled out as “PV”-morphology. When a temporal/locative DP embedded

⁴⁰ As mentioned in Chapters 2 and 4, the argument marker Y in some languages also marks adjuncts. I assume this to be similar to English, where inherent Case assigned within a PP shares the same marking with accusative Case (e.g., [to/ from *him/her/them*]).

under a prepositional phrase carries a [topic]-feature, the bundle of topic-agreement (δ -agreement) and a specific-agreement relation within the PP is spelled out as “LV”-morphology. Finally, when a phrase that is not under another Agree relation carries a [topic]-feature, bare topic-agreement (δ -agreement) is spelled out as “CV”-morphology. If this proposal is on the right track, Philippine-type “voice” affixes are essentially topic-indicating morphology.

Based on the observations in Chapters 4 and Section 5.5, I proposed that the δ -probe is hosted at a projection independent from that of the ϕ -probe (i.e., T). I tentatively assume this position to be (a layer of) C.⁴¹

The assumptions summarized so far come together to construct the design of the Philippine-type voice system illustrated in (91):

(91) *Proposal: What makes a Philippine-type voice system*

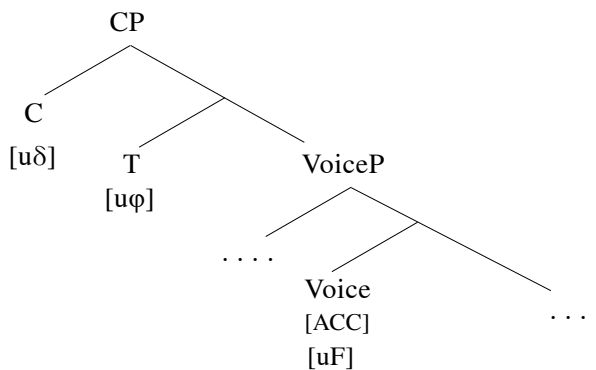

Under this analysis, Philippine-type languages employ two distinct positions for topics and subjects: the former is hosted at [Spec CP] and the latter at [Spec TP], similar to what has been argued for English (e.g., Richards 2007; Chomsky 2008; Miyagawa 2010, 2017). In what follows, I review the nature of Philippine-type languages under the current analysis from a crosslinguistic perspective.

5.5.2 Philippine-type languages as discourse-configurational languages

It is common practice in the typological and syntactic literature make a distinction between *subject prominent* and *topic prominent languages* (e.g., Li & Thomspon 1976; Givón 1983; Sasaki 1990; Miyagawa 2010, 2017). Topic-prominent languages use morphology or syntax to index the role of the topic (92), as opposed to subject prominent languages, which employ overt morphology for ϕ -agreement.

⁴¹ See Appendix I for a discussion of the empirical evidence for this assumption.

(92) *Topic-prominent languages (Li & Thompson 1976)*

A topic-prominent language is a language that employs morphology or syntax that highlights the distinction between the topic and the comment (what is said about the topic).

More recent work has broadened this view to a more general division between prominence of grammatical relations or prominence of discourse configurationality. Kiss (1995) has argued that the discourse-semantic function ‘topic’ or ‘focus’, serving to foreground a specific individual that something will be predicated about, is expressed through a particular structural relation.

In the view of the analysis presented in this chapter, Philippine-type Austronesian languages exhibit the hallmarks of topic-prominent languages and discourse-configurational languages, whereby topichood in these languages is manifested both in (i) topic-marking that overrides morphological case and (ii) articulated verbal morphology that spells out the Agree relation(s) associated with the internal topic of the clause. We can conclude that topics play an important role in the morphosyntax of Philippine-type languages.

5.5.3 Conclusion

In this chapter, I argued that Philippine-type languages are best characterized as topic-prominent languages (Li & Thompson 1976) with a nominative-accusative case system. I showed that in Philippine-type languages, the internal topic carries prominent morphological marking that overrides morphological case, and its grammatical relation (subject vs. direct object) is encoded in verbal morphology. This system can be characterized as employing a topic-probe on C and a ν -probe on T, which spells out types of Agree relations that target the topic of the clause. The spell-out of the different bundles of Agree relations is conventionally called the “voice affix”.

If this analysis is correct, Philippine-type “voice” is fundamentally different from the conventional notion of “voice”, which is valency-rearranging morphology hosted at or below Voice⁰.

Chapter 6

Austronesian primary-level subgrouping: Current issues

Recent work has defined Austronesian primary-level subgrouping based on one of two types of morphosyntactic variation among languages: (i) the presence or absence of *nominalizer-voice affix (noun-verb) homophony* (Ross 2009, 2012) and (ii) the presence or absence of *ergativity* (i.e., Philippine-type voice distinctions in root clauses) (Starosta 1995; Aldridge 2016). Both approaches rely on the assumption that the presence of the feature reflects a *single, shared innovation* that defines an innovative Austronesian primary branch. However, conclusions reached by this line of analysis are incompatible with the consensus built on phonological evidence (Blust 1999), leaving Austronesian primary-level subgrouping open to debate. In this chapter and the next, I investigate the conflicts among proposals reached by these three different approaches, and demonstrate that (i) and (ii) are both built on inaccurate understanding of the synchronic syntax of Philippine-type languages, which therefore do not constitute sound evidence for Austronesian primary-level subgrouping.

In this chapter, I first identify major conflicts among proposals built on these three different subgrouping approaches, and evaluate the three approaches in three ways: (a) compatibility with the analyses of the synchronic syntax presented in Chapters 2–5, (b) methodological soundness, and (c) compatibility of implied homelands with the archeological record and the sociocultural classifications of Formosan aborigines. Drawing on these evaluations, I conclude that exclusively shared phonological innovations provide a more reliable means of subgrouping than other alternatives. Building on this conclusion, I reconsider the evolutionary pathway of the variation in (i)–(ii) in Chapters 7.

6.1 Introduction

6.1.1 The puzzle

As languages evolve over time, observations of shared innovations inform linguistic genetic relations. In principle, types of innovations should point to compatible subgrouping scenarios. When proposals fail to agree, they should be treated with caution. In this chapter, I investigate a puzzle in Austronesian primary-level subgrouping, where different types of evidence yield conflicting results.

Austronesian primary-level subgrouping has remained controversial due to divergent claims reached by different criteria. Based on the type of evidence used, existing proposals fall into three classes: (i) phonological innovations (e.g. Tsuchida 1976; Li 1985; Ho 1998; Blust 1999) (henceforth Approach A), (ii) the presence or absence of N-V homophony (Ross 2009, 2012; Zeitoun & Teng 2016) (henceforth Approach B), and (iii) the presence or absence of ergativity (a Philippine-type voice system) (Starosta 1985, 1995; Aldridge 2016a) (Henceforth Approach C).¹

Approach A draws on the traditional practice of the Comparative Method on *phonological innovations*. Under this approach, Proto-Austronesian contains no fewer than 10 primary branches, nine of which are located in Taiwan (Blust 1999), as in (1):

(1) FIGURE 6.1. Approach A: Exclusively shared phonological innovations

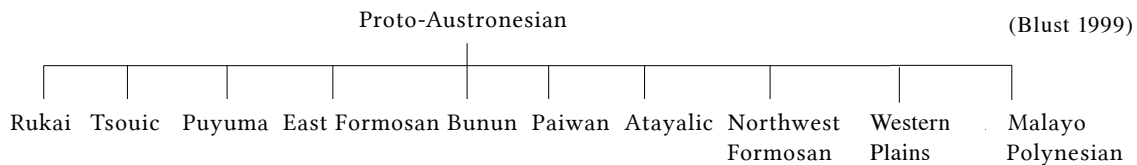

Under Approach B, Proto-Austronesian gave rise to three single-member primary branches, *Rukai*, *Tsou*, and *Puyuma*, and a fourth branch, *Nuclear Austronesian*, which consists of all other languages (2). This subgrouping approach draws on a diachronic proposal originated in Starosta, Pawley, & Reid (1982), that the phenomenon of *nominalizer-voice affix homophony* observed in many Philippine-type languages arose from a putative archaic morphosyntactic innovation called “*Nominalization-into-V*” (*Nom-into-V*), which gave rise to the synchronic homophony between Philippine-type voice affixes present in indicative clauses and their functionally corresponding nominalizers used in relative clauses. Adopting this hypothesis, Ross (2009) has attributed the lack of N-V homophony in Rukai, Tsou, and Puyuma to their being excluded from the purported innovation. Under this proposal, Proto-Austronesian underwent a four-way split, and the Nuclear Austronesian branch is defined by the putative emergence of N-V homophony.

(2) FIGURE 6.2. Approach B: Presence or absence of N-V homophony

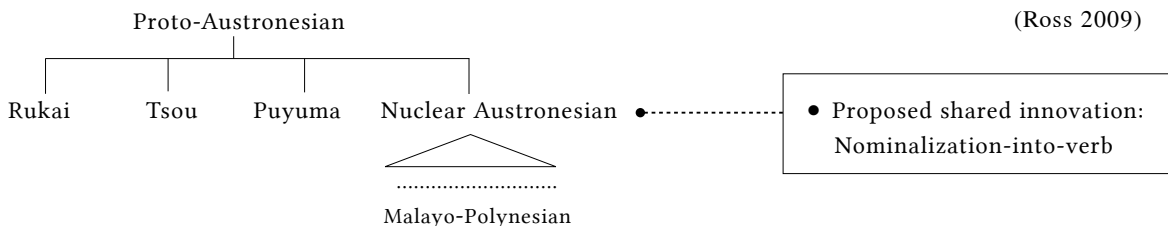

¹ Sagart (2004, 2008, 2014) has proposed another subgrouping based on proposed innovations in the numeral systems of higher-order Austronesian languages. As comprehensive critiques of this proposal have been made in Teng & Ross (2010) and Blust (2014), I do not discuss it further in this dissertation.

A third proposal holds that Proto-Austronesian split into Rukai vs. the rest, based on the observation that Rukai is the only higher-order Austronesian language that lacks Philippine-type voice distinctions in root-clause environments. On the assumption that Philippine-type voice systems are ergative (Aldridge 2004, 2008, 2011), this approach defines Austronesian primary-level subgrouping by the putative emergence of ergativity, which excluded Rukai, as in (3) (Aldridge 2014, 2016).

(3) *FIGURE 6.3. Approach C: Presence or absence of ergativity*

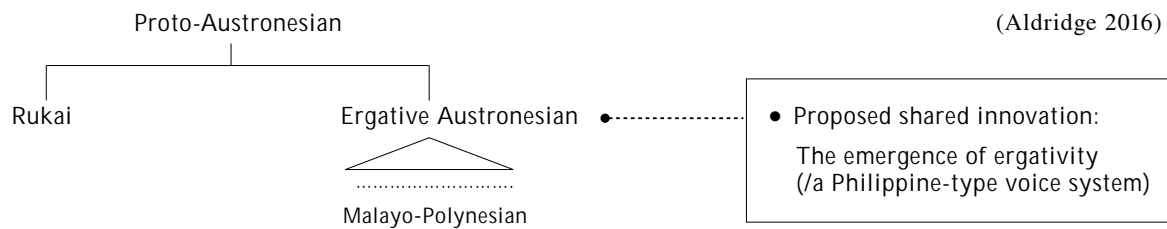

The conflict among (1)–(3) has produced an ongoing debate. As seen in (1), the phonology-based subgrouping recognizes Tsou, Saaroa, and Kanakanavu as members of the same primary branch, whereas Approach B separates them into two distinct branches. The three approaches also diverge in their inferences for the morphosyntax of Proto-Austronesian and the locus of the Austronesian homeland. These conflicts will be discussed in detail this chapter.

If all of these approaches are valid, they should be mutually compatible. In this chapter, I investigate the nature of their conflicts and argue for the analysis in (4).

(4) *Main claims of the chapter*

- a. *Exclusively shared phonological innovations* (Approach A) provide a more reliable means of subgrouping, as phonological innovations in general follow a more predictable direction of change than morphosyntactic innovations.
- b. Approaches B and C are not reliable means of subgrouping, as both are founded on a specific diachronic interpretation that allows other alternatives.

This chapter is organized as follows. I begin by reviewing the phonological innovations in higher-order Austronesian languages in Section 6.2, and turn to Approaches B and C in Sections 6.3–4. Section 6.5 identifies conflicts among the three approaches and outlines possible explanations for the conflicts. Section 6.6 evaluates the three approaches and concludes that Approach A is optimal. Section 6.7 concludes.

6.1.2 Austronesian primary-level subgrouping: Overview

There has been a consensus in the literature that Taiwan is the homeland of the Austronesian language family, known as the *Out-of-Taiwan Hypothesis* (Bellwood 1984–5, 2004; Blust 1984–5, 1999). This proposal is supported by comparative evidence summarized below:

(5) TABLE 6.1. Shared innovations that define the Malayo-Polynesian (MP) branch

a. phonological innovations	<ol style="list-style-type: none"> 1 PAn *N/n > PMP *n² 2 PAn *C/t > PMP *t³ 3 PAn *S/h > PMP *h⁴ 4 Irregular loss of PAn *S > zero⁵
b. morphological innovations	<ol style="list-style-type: none"> 1 PMP { *maN-, *paN- }, { *maR-, paR- }, { *maka-, *paka- }, { *maki-, *paki- }
c. other innovations	<ol style="list-style-type: none"> 1 PMP politeness shift: PAn *-mu ‘2Pl. Gen.’ > PMP *-mu ‘2Sg.Gen.’ 2 PAn *biRbiR > PMP *bibiR ‘lips’ 3 PAn *Siwa > PMP *siwa ‘nine’ 4 PAn *paŋudaN > PMP *paŋdan ‘pandanus’ 5 Metatheses: PAn *-CVS > variation between *-hVC and *-CVh in MP⁶

As seen in (5), Austronesian languages spoken outside Taiwan share a number of innovations that distinguish them from Formosan languages, ranging from phonemic mergers to morphosyntactic and lexical innovations (Mills 1975; Dahl 1973; Blust 1977, 1999, 2001, 2013; Kaufman 2009; Liao 2011a, b; Ross 2012). These innovations strongly suggest that all extra-Formosan Austronesian

-
- ² Sample vocabulary:
 - 1 PAn *qaNiCu > PMP *qanitu ‘ghost’
 - 2 PAn *NaCeŋ > PMP *nateŋ ‘vegetables’
 - 3 PAn *naNaq > PMP *nanaq ‘pus’
 - 4 PAn *ka-nu ‘interrogative’ > PMP *ka-nu ‘when?’
- ³ Sample vocabulary:
 - 1 PAn *Caliŋa > PMP *taliŋa ‘ear’
 - 2 PAn *Cakaw > PMP *takaw ‘steal’
 - 3 PAn *tabaN ‘head trophy’ > PMP *taban ‘booty’
 - 4 PAn *t-ina > PMP *t-ina ‘mother’
- ⁴ Sample vocabulary:
 - 1 PAn *SabaN > PMP *hahan ‘cloth used to carry a child on the back’
 - 2 PAn *SabaRat > PMP *habaRat ‘south wind’
 - 3 PAn *hukaq > Tausug *ma-huka?* ‘to loosen, open’
 - 4 PAn *hulhul > Cebuano *hulhúl* ‘to bark’
- ⁵ Sample vocabulary:
 - 1 PAn *Sipes > PMP *ipes ‘cockroach’
 - 2 PAn *Sepat > PMP *epat ‘four’
 - 3 PAn *Si- > PMP *-i- ‘circumstantial voice affix’
 - 4 PAn *Sepat ‘four’ > Tagalog *apat*, Kayan *pat*, Old Javanese *pat*
- ⁶ Sample vocabulary:
 - 1 PAn *CaqiS > PMP *tahiQ ‘sew’
 - 2 PAn *tuđuS > PMP *tuहुद ‘knee’
 - 3 PAn *bukeS > PMP *buhek ‘head hair’

languages were derived from a single ancestral language, conventionally referred to as *Proto-Malayo-Polynesian* (e.g. Mills 1975:581; Blust 1977, 2001).

While Malayo-Polynesian as a single higher-order branch of Austronesian is not controversial, the interrelationship among Formosan languages remains a central issue in Austronesian linguistics (e.g. Starosta 1985, 1995; Ho 1998; Blust 1999; Sagart 2004, 2008, 2014; Ross 2009, 2012, 2014; Kikusawa 2012; Teng & Ross 2010; Aldridge 2014, 2016; Zeitoun & Teng 2014, 2016; Chen 2015; Blust & Chen 2017). As these languages occupy the highest positions of the language family, Austronesian primary-level subgrouping remains unsettled, as illustrated in (6):

(6) *FIGURE 6.4. Austronesian primary-level subgrouping: the current issue*

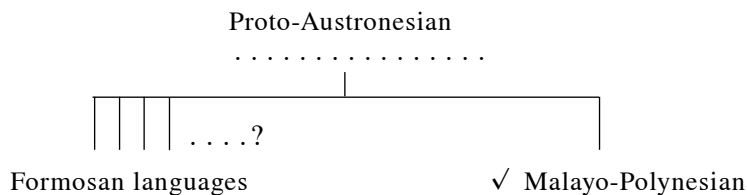

6.2 Reconsidering Approach A: The phonological evidence

In this section, I review the phonological evidence for Austronesian primary-level subgrouping. To keep the discussion concise, I focus on the major differences between two well-received proposals, Ho (1998) and Blust (1999), and acknowledge their consensus as valid subgroups. I show that Blust's treatment provides a more reliable means of classification, as it is based on *exclusively shared innovations*.⁷ Under this conclusion, the phonological evidence suggests that the Austronesian family comprises no fewer than 10 primary branches, nine of which are located in the Austronesian homeland, Taiwan.

6.2.1 What constitutes reliable phonological evidence for linguistic subgrouping?

Before starting the discussion, I outline several fundamental assumptions.

In evaluating the strength of phonological innovations as subgrouping criteria, I adopt the idea that *not all sound changes are of equal weight*. Two principles assumed under this view are summarized in (7):

⁷ See the Methodology section in Chapter 1 for a comprehensive discussion of the standard methods of linguistic subgrouping.

(7) *Principles in evaluating the weight of a phonological innovation*⁸

- a. Exclusively shared innovations have more weight for subgrouping than non-exclusively shared ones.
- b. Sound changes that are crosslinguistically rare have more weight for subgrouping than common changes.

The term *exclusively shared innovation* in (7a) requires some clarification. In actual practice, the supposition ‘X is an exclusively shared innovation of Languages A, B, and C’ subsumes two basic assumptions: First, X is an innovation, rather than a retention from a proto-language that is not an immediate ancestor of A, B, and C. Second, X is the result of a single historical change that took place in a language immediately ancestral to A, B, and C, rather than of borrowings or parallel changes (i.e. drifts). If the latter is the case, X has no subgrouping value, as it does not indicate a shared origin. With these principles in mind, I begin with an overview of the phonology-based subgroupings.

6.2.2 Phonological evidence for Austronesian primary-level subgrouping: Overview

Beginning with Dyen (1965) and Ferrell (1969), much previous work has defined Austronesian primary-level subgrouping based on sound correspondences (e.g. Dahl 1973; Tsuchida 1976; Blust 1977; Harvey 1982; Ho 1998; Reid 1982; Li 1985, 1990; Dyen 1990; Ho 1998, Blust 1999). Among these works, Ho (1998) and Blust (1999) are the most recent studies that strictly follow the Comparative Method and provide explicit discussion of the treatment of each subgroup. In this dissertation, I take them as representative of the phonology-based subgroupings.

6.2.2.1 Overview of Ho (1998) and Blust (1999)

Ho (1998) investigates the interrelationships among 19 Formosan languages, with an implicit assumption that all extra-Formosan languages belong to a single primary branch (Malayo-Polynesian). Under his analysis, the Austronesian family contains seven primary branches: *Rukai-Tsouic*, *Puyuma*, *Atypical Formosan*, *Paiwan*, *Pazeh-Saisiyat-Atayalic*, *Western Plains*, and *Malayo-Polynesian*, six of which are situated in Taiwan, as in (8):

⁸ These principles were originally discussed in Blust (1999) and are adopted in this dissertation.

(8) FIGURE 6.5. Ho's (1998) subgrouping

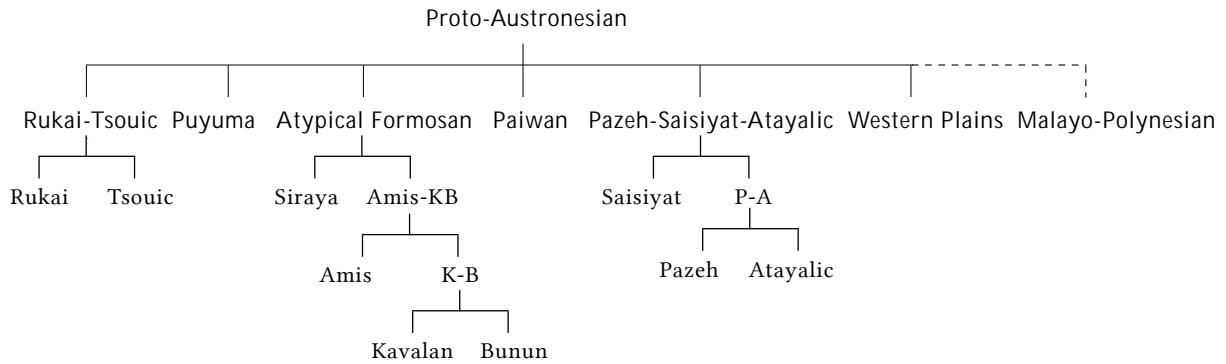

Blust (1999) addresses both the position of Malayo-Polynesian and the interrelations of Formosan languages. Besides the 19 languages discussed in Ho (1998), it includes two extinct Formosan languages, Basay-Trobiawan and Kulon, based on Tsuchida's (1985) study of early written records. Under this consensus subgrouping, the Austronesian language family contains 10 primary branches: *Rukai*, *Tsouic*, *Puyuma*, *East Formosan*, *Bunun*, *Paiwan*, *Atayalic*, *Northwest Formosan*, *Western Plains*, and *Malayo-Polynesian*, as in (9):

(9) FIGURE 6.6. Blust's (1999) subgrouping

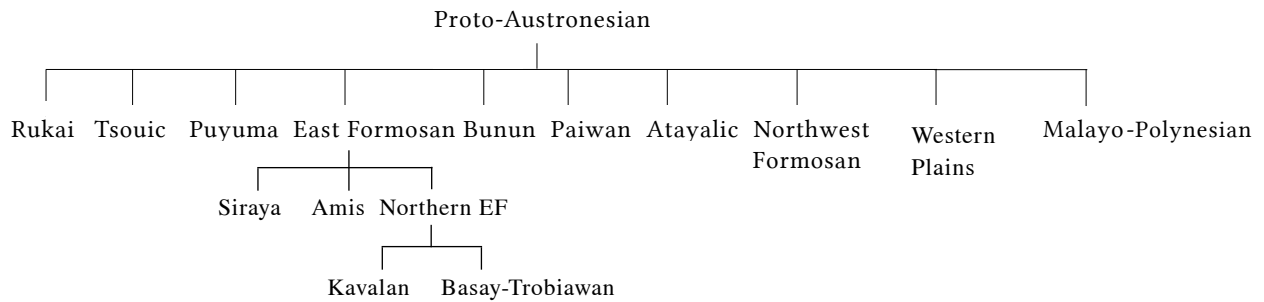

As seen above, Ho (1998) and Blust (1999) diverge in the treatment of Bunun, Tsouic, and Atayalic, even though both are based on phonological innovations. In Blust (1999), each of these is a primary branch of Austronesian, while in Ho (1998) they are part of larger primary branches. This treatment reduces the number of primary branches in Ho (1998) to seven. To investigate the factors responsible for these differences, I present a detailed review of the two works in the following subsection.

6.2.2.2 Three major differences between Ho (1998) and Blust (1999)

Table (10) is a comparison of the Proto-Austronesian (PAN) reconstruction used in Ho (1998) and Blust (1999).

(10) TABLE 6.2. Proto-Austronesian consonant systems adopted in Ho (1998) and Blust (1999)

Ho (1998)	*p	*t	*T	*C	*k	*q	*b	*d	*D	*d'	*g'	*g	*m	*n	*l	*ñ	*ŋ	*t'	*θ	*s	*f	*l	*r	*y	*h	*h̃
Blust (1999)	*p	*t	*C	*k	*q	*b	*d	*z	*j	*g	*m	*n	*N	*ñ	*ŋ	*s	*S	*l	*r	*R	*h					

As seen in (10), Ho recognizes five phonemic distinctions that are not acknowledged in Blust (1999): *t/T, *d/D, *t'/θ, *s/f, and *h/h̃. To be concise, I summarize the motivations of each distinction in footnote 9 and discuss them only where relevant.

Table 6.3 is a revised tabulation of sound correspondences among higher-order Austronesian languages, based primarily on Blust (1999:43, 2013:583) with modifications based on Ting (1976:342–88), Ho (1978:604–77; 1998:163–66), Li (1977), Ross (2012: 1274–5), and the Austronesian Comparative Dictionary (ACD) (Blust & Trussel ongoing).⁹ The lighter grey cells indicate important mergers that define major language groups.

⁹ The comparative evidence that motivates each distinction is summarized below:

- a. **Evidence for a *T/t distinction:** The reconstruction of PAN *T and *t was motivated by an unconditioned split of Proto-Austronesian *t in Javanese (Dempwolff 1934-38; adopted in Li 1985 and Ho 1998). As words with this split are not attested in higher-order Austronesian languages, a PAN *T/t distinction has been abandoned in recent works (cf. Blust 1999, 2009[2012]; Ross 2012).
- b. **Evidence for a *d/D distinction.** The motivation of reconstructing multiple subsets of *d to PAN comes from two distinct sources. The first is the unconditioned split of *d in two Formosan languages, Paiwan and Puyuma (see (9)), which has motivated a *d/D distinction in some work. The second is motivated by an unconditioned split of *d in word-final position in around ten Western Indonesian languages (Dahl 1976; Blust 2009[2012]). As the latter is attested only in these lower-level languages, it has been abandoned in the recent work (cf. Blust 1999; Ross 2012).
- c. **Evidence for the *θ/t' and *s/f distinctions.** See Section 6.2.5.2 for a discussion.
- d. **Evidence for an *h/h̃ distinction.** A PAN *h/h̃ distinction was motivated by an *h/∅* contrast in word-final position in Amis, Saisiyat, Pazeh, Atayal, and Seediq, as first proposed in Tsuchida (1976:132). Reflexes of these two proposed phonemes can be found in Ho (1998:165).

(11) TABLE 6.3. Sound correspondences among higher-order Austronesian languages

PAN	HO	*p	*t	*T	*C	*k	*q	*b	*d	*D	*d'	*g'	*g	*m	*n	*l	*ñ	*ŋ	*t'	*θ	*s	*ʃ	*l	*r	*y	*h	*fi
	BLUST	*p	*t	*C	*k	*q	*b	*d	*z	*j	*g	*m	*n	*N	*ñ	*ŋ	*s	*S	*l	*r	*R	*h					
Paiwan		p	tj	tj	ts	k	q	v	dj	dr,z	dj	d	g	m	n	L	L	ŋ	t	t	s	s	lr	--	r,∅	∅	?
P-Puyuma		p	t	t	tr	k	ʔ	b	d	dr	d	d	h	m	n	l	l	ŋ	s	s	∅	∅	lr	r	r	∅	?
P-Rukai		p	t	t	c	k	∅	b	dr	dr	d	g,∅	g	m	n	--	l	ŋ	s	θ,s	sh	s	lr	--	r,∅	∅	∅
Tsou		p	t	t	c	ʔ, k	∅	f	c	c	c	∅	k	m	n	h,k	n	ŋ	s	s	s	∅	r	r	r	∅	∅
Kanakanavu		p	t	t	c	k	ʔ	v	s-	c	c	l	k	m	n	ŋ	n	ŋ	s,∅	s	s,∅	∅	l	r	r	∅	∅
Saaroa		p	t	t	c	k	ʔ	v	s	s	s	L,∅	k	m	n	L	L	ŋ	∅	s	s,∅	∅	l	r	r	∅	?
Bunun		p	t	t	t	k	q	b	d	d	d	∅	k	m	n	n	n	ŋ	c	c	s	s,∅	∅	l	l	h	?
Amis		p	t	t	t	k	ʔ	f	r	r	r	n	--	m	n	d	d	ŋ	c	c	s	s	l	--	l	h	?
Kavalan		p	t	t	t	q	∅	b	z	z	z	n	--	m	n	n	n	ŋ	s	s	s	s	r	--	r,l	∅	--
Basay		p	t	t	t	k	∅	b	ts-	l	l	n	--	m	n	--	n	ŋ	ts	ts	s	ts	ts	--	l	?	?
Trobiawan		p	t	t	t	k	∅	v	z	ʔ	ts	n	--	m	n	--	n	ŋ	ts	ts	s	ts	ts	--	l	?	?
Siraya		p	t	t	t	k	∅	v	s	s	d	n	--	m	n	l	l	ŋ	s	s	x	∅	r	--	x	∅	--
Taokas		p,∅	t	t	s	k,∅	h	b	t	d?	t	t,∅	--	m	n	--	t	n	t	t	sh	∅	l,r	--	l	h	--
Hoanya		p	t	t	s	k	∅	b	d	d,∅	dz	dz	--	m	n	--	s	ŋ,n	t	t	s	∅	l	--	--	h	--
Babuza		p,∅	t	t	ch	∅	∅	b	t	d,r	t	d	--	m	n	--	s,l	n	t	t	s	∅	r	--	r	h	--
Papora		p,∅	t	t	s	∅	∅	b	t,d	--	d	d,∅	--	m	n	--	l	n	t	t	s	∅	r	--	l	h	y
Thao		p	t	t	c	k	q	f	s	s	s	z	--	m	n	z	z	n	t	t	sh	∅	r	--	lh	∅	?
P-Atayalic		p	t	t	c	k	q	b	d	d	d	g	--	m	n	l	l	ŋ	h	h	s	h	r	--	g	h	?
Pazih		p	t	t	s	k	∅	b	d	d	d	z,-t	--	m	n	--	l	ŋ	z	z	sh	h	r	--	x	h	h
Saisiyat		p	t	t	s	k	ʔ	b	r	r	r	z	--	m	n	l	l	ŋ	h	h	sh	h	L	--	L	h,∅	h,∅
Kulon		p	t	t	s	k	∅	b	z	ʔ	--	--	--	m	n	--	r	n	h	h	s	h	r	--	--	?	?
PMP		*p	*t	*t	*t	*k	*q	*b	*d	*d	*z	*j	*g	*m	*n	*n	*ñ	*ŋ	*s	*s	*h	*h	*l	*r	*R	*h,∅	?

Table 6.4 summarizes major phonological innovations that define each primary branch in Ho (1998) and Blust (1999). The abbreviation ESI in (12) stands for ‘exclusively shared innovation’.

(12) TABLE 6.4. Phonological innovations used in Ho (1998) and Blust (1999)

	Blust (1999)	Ho (1998)	Notes
Paiwan	No ESI with others	No ESI with others	Consensus
Puyuma	No ESI with others	No ESI with others	Consensus
Western Plains	1 Merger of *n and *ŋ 2 Merger of *s and *t 3 Truncation of -ay/-aw	1 Merger of *n and *ŋ 2 Merger of *t, *t', and *θ	Consensus

	Blust (1999)	Ho (1998)	Notes
Tsouic	1 Merger of * <i>k</i> and * <i>g</i> 2 Merger of * <i>j</i> and \emptyset 3 Merger of * <i>S</i> and * <i>s</i> 4 Merger of * <i>R</i> and * <i>r</i>	•Evidence for RUKAI-TSOUIC: 1 Merger of * <i>s</i> , * <i>t</i> , and * θ 2 Merger of * <i>r</i> and * <i>y</i> •Evidence for TSOUIC: 1 Merger of * <i>k</i> and * <i>g</i> 2 Merger of * <i>D</i> , * <i>d</i> , and * <i>d'</i>	B: Primary branch H: under RUKAI-TSOUIC
Rukai	No ESI with others		B: Primary branch H: under RUKAI-TSOUIC
Bunun	No ESI with others (* <i>C</i> /* <i>t</i> merger as drift)	•Evidence for ATYPICAL FORMOSAN (Bunun + EF): 1 Merger of * <i>C</i> and * <i>t</i>	B: Primary branch H: grouped with EF
East Formosan (EF)	1 Merger of * <i>j</i> and * <i>n</i> 2 Merger of * <i>C</i> and * <i>t</i> (occurred also in Bunun and PMP)	•Evidence for AMIS-BUN-KAV: 1 Merger of * <i>s</i> and * <i>f</i> •Evidence for BUNUN-KAVALAN: 1 Merger of * <i>n</i> and * <i>n̄</i>	B: Primary branch H: grouped with BUNUN
Atayalic	No ESI with others	• Evidence for PAZIH-SAISYAT-ATAYALIC: 1 Merger of * <i>D</i> and * <i>d</i>	B: Primary branch H: grouped with NP
Northwest Formosan (NF)	1 * <i>C</i> > <i>s</i> 2 * <i>q</i> > \int/\emptyset	• Evidence for SAISYAT as an independent subbranch: 1 Merger of * <i>l</i> and * <i>y</i> 2 Merger of * <i>h</i> and * <i>h̄</i>	B: Primary branch H: grouped with ATAYALIC
Malayo-Polynesian (MP)	1 Merger of * <i>C</i> and * <i>t</i> 2 Merger of * <i>h</i> and * <i>S</i> 3 Merger of * <i>N</i> and * <i>n</i> 4 PAn * <i>CVS</i> > PMP <i>hCV</i> 5 PAn * <i>Siwa</i> > PMP * <i>siwa</i> 'nine'	—	—

As seen above, the two proposals show a considerable amount of consensus. Both identify Paiwan and Puyuma as single-member primary branches and a Western Plains branch consisting of Thao, Babuza, Hoanya, Toakas, and Papora. Also, both proposals recognize an Atayalic language group comprised of Atayal and Seediq, and a Tsouic language group comprised of Tsou, Saaroa, and Kanakanavu, despite disagreement on their external relations. Finally, both consider Siraya, Amis, and Kavalan as members of the same language group, although they differ in whether Bunun should also be included.

The difference between the two subgroupings therefore boils down to the positions of Bunun, Rukai, and Atayalic. In what follows, I review the comparative evidence that motivates these differences.

6.2.3 Reconsidering three divergences between Ho (1998) and Blust (1999)

In this subsection, I revisit the positions of Bunun (6.2.3.1), Rukai (6.2.3.2), and Atayalic (6.2.3.3) and conclude that all three are best analyzed as independent primary branches.

6.2.3.1 The position of Bunun

A major difference between Ho (1998) and Blust (1999) concerns the position of Bunun and its potential relation with the East Formosan languages. In Ho (1998), Bunun is placed under an Atypical Formosan branch with Siraya, Amis, and Kavalan, defined by their shared merger of PAn *C/t. As this merger is also attested in all Austronesian languages spoken outside Taiwan (see (11)) and regarded as a non-Formosan feature, this branch is named *Atypical Formosan*.

Internal to this branch, two lower-level subgroups are defined by the mergers of PAn *S/s and *n/ñ/N, which place Bunun at the bottom of the branch, as illustrated in (13):

(13) FIGURE 6.7. The position of Bunun: Ho (1998)

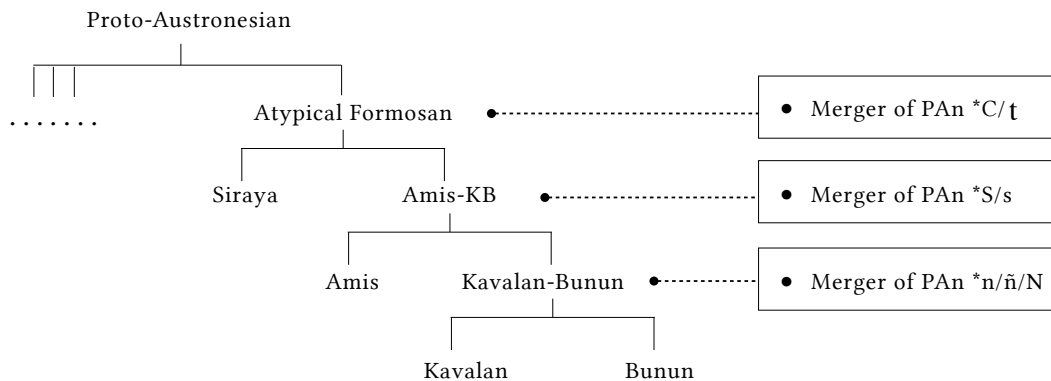

Blust (1999), on the other hand, does not acknowledge an Atypical Formosan branch. Members of this branch except Bunun are placed under an independent primary branch, *East Formosan*, defined by a unique merger of Proto-Austronesian *j/n that excludes Bunun. As Bunun does not show any exclusively shared innovation with others (cf. (11)), it is analyzed as a single-member primary branch, as in (14):

(14) FIGURE 6.8. The position of Bunun: Blust (1999)

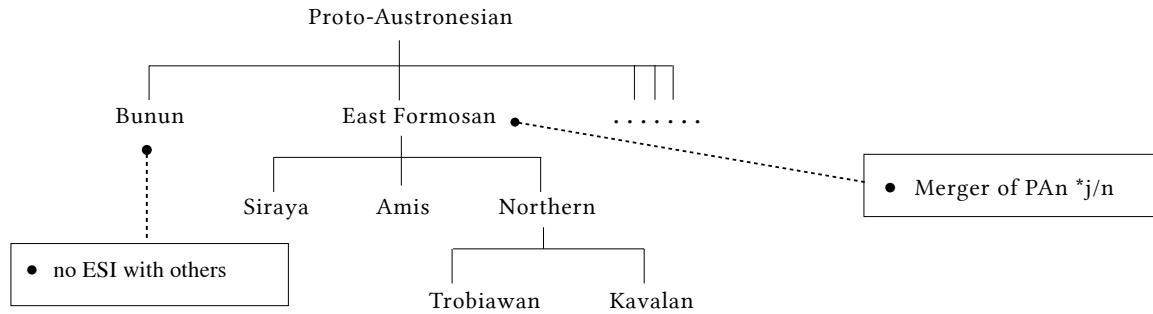

To summarize, the East Formosan branch crosscuts the Atypical Formosan branch, appealing to a merger that is not recognized in Ho (1998). The latter is defined by three mergers: 1) PAn *C/t, which identifies members of this subgroup, 2) PAn *s/f, which excludes Siraya from the rest, and 3) PAn *n/ñ/ɿ (*N), which places Bunun and Kavalan in sisterhood, as in (13). Therefore, under the East Formosan proposal, these three mergers are interpreted as drifts that occurred independently in Bunun and East Formosan.

(15) TABLE 6.5. The treatment of Bunun and East Formosan languages: Ho (1998) vs. Blust (1999)

a. Ho (1998)		b. Blust (1999)	
1. Merger of *C and *t (occurred in Bunun, East Formosan, and PMP)	Atypical Formosan	1. Merger of *j and *n (occurred only in EF languages)	East Formosan
2. Merger of *s and *f (both = Blust's *S) (occurred in Bunun, Amis, Kavalan, and Tsouic)	Amis-BK		
3. Merger of *n, *ñ, and *ɿ (Blust's *N) (occurred in Bunun and Kavalan)	Bunun-Kavalan (BK)	1. No ESI with others (only convergences)	Bunun

Under the principle outlined in Section 6.2.1, sound changes that are crosslinguistically rare and/or are exclusively shared by the target languages constitute stronger evidence for subgrouping, as they are less likely to be a consequence of independent parallel changes (drifts). The *j/n merger that defines East Formosan thus stands as solid subgrouping evidence. As it is not attested anywhere else across the entire Austronesian family (Blust 1999:49), its uniqueness lowers the probability of it being a product of drift in five geographically adjacent languages.

On the other hand, none of the three mergers for Atypical Formosan are exclusively shared innovations. A separate case of *C/t merger is attested in all extra-Formosan languages. The *s/f merger defining the first internal layer of Atypical Formosan occurs also in Paiwan, Puyuma, and

Proto-Malayo-Polynesian, and is based on a phonological distinction that is not universally accepted.¹⁰ The *n/ñ/ɺ (*N) merger that defines a Bunun-Kavalan subgroup under Atypical Formosan is widely attested in Malayo-Polynesian languages, including Yami, Cebuano, Tboli, and Ifugaw. As they are not exclusively shared, these innovations provide only weak support for Atypical Formosan, as opposed to the East Formosan branch, which is defined by a typologically rare sound change.¹¹

To conclude, given the uniqueness of the *j/n merger, treating Bunun and East Formosan as two independent primary branches has more strength than other alternatives.

6.2.3.2 *The validity of Rukai-Tsouic*

A second divergence between Ho (1998) and Blust (1999) concerns the positions of Rukai and Tsouic. Both proposals acknowledge a Tsouic language group consisting of Tsou, Saaroa, and Kanakanavu, but place it at different levels. Blust considers Tsouic as a primary branch, while Ho analyzes it as a sister of Rukai, defined by two shared mergers that are not acknowledged in Blust (1999): PAn *t̥/θ/s and *r/ɣ. The validity of this proposal therefore boils down to the reliability of these two mergers as subgrouping evidence.

The answer to this question goes back to a fundamental aspect of linguistic subgrouping: the phoneme system of the proto-language assumed in the subgrouping proposal. As seen in (10), the PAn system used in Ho (1998) and several other works adopts the distinctions of PAn *θ/t̥ and *s/ʃ, which are not adopted by Blust, who holds a conservative view toward reconstructing separate proto-phonemes based on limited etyma. The purported merger of PAn *t̥/θ/s that defines Ho's Rukai-Tsouic branch therefore does not apply to Blust's subgrouping, which does not acknowledge a distinction between PAn *t̥ and *θ.

(16) TABLE 6.6. *The correspondences of PAn *s and *S in different PAn reconstruction systems*

Blust (1999)	*s		*S	
Tsuchida (1976)	*s	*θ	*S ₁	*S ₂
Li (1985)	*t̥'	*θ	*s	*ʃ
Ross (2012)	*s	*θ	*x	*S

¹⁰ As seen in (10), a PAn *s/ʃ distinction is not acknowledged in Blust's reconstruction.

¹¹ A potential analysis that combines the treatments in the two proposals is to identify an Atypical Formosan branch supported by the *C/t merger, and to recognize Bunun and East Formosan as sisters based on the *j/n merger. This analysis, however, does not seem to have an advantage over the treatment in Blust (1999). To the best of my knowledge, there is no obvious evidence that suggests a common origin between Bunun and East Formosan. Bunun exhibits relatively simple morphosyntax with a less elaborate two-way case-marking system. Although such differences are not counterevidence for the current proposal—as Bunun is analyzed as an outlier under Atypical Formosan—there is no obvious reason to favor this treatment either.

No matter which reconstruction system is adopted, the proposed merger of PAn *t'/θ/s that defines the Rukai-Tsouic branch appears unmotivated. As the reconstruction of a PAn *θ is driven by the unconditioned split of PAn *s in Rukai dialects (Tsuchida 1976; Li 1985), there is essentially no *θ/s merger in Rukai, as opposed to Ho's report.¹² The distinctions between Rukai and Tsouic reflexes of the three phonemes is shown in (17):

(17) TABLE 6.7. The correspondences of Rukai and Tsouic sibilants¹³

Proto-Austronesian (Li 1985)	*t' (*s)	*θ	*s (*S ₁)	*ʃ (*S ₂)
Proto-Rukai	*s	*θ	*s	*S
Tsou	s	s	∅	s
Kanakanavu	∅-∅- <i>s</i> /∅	s	∅	s- <i>s</i> /∅- <i>s</i>
Saaroa	∅	s	∅	<i>s</i> /∅-∅- <i>s</i> /∅

Given (17), the purported merger of PAn *t'/θ/s in Ho (1998) appears unsupported, as Rukai and Tsouic show no evidence of a shared *θ/s merger.

The second piece of evidence for Rukai-Tsouic branch also seems untenable. Ho reports that Rukai and Tsouic share the merger of *r/ɣ, which contradicts Li's (1977) descriptions that (i) PAn *ɣ (= *R in Blust (1999)) underwent an unconditioned split into *r* and *ʔ* in Proto-Rukai, and (ii) PAn *r has no attested reflex in Rukai. According to (i)-(ii), Proto-Rukai did not undergo a *ɣ/r merger, although the merger is indeed attested in the three Tsouic languages, as seen in (17). The second argument for Rukai-Tsouic therefore does not constitute a valid criterion either.

It can thus be concluded that there is no sound evidence for a Rukai-Tsouic branch. As seen in (9), the three Tsouic languages share four phonological innovations from Proto-Austronesian,

¹² The following illustrates the unconditioned split of PAn *s (cf. ACD; Tsuchida 1976:129; Li 2004[1977]:588):

A. PAn *s > Proto-Rukai *θ:

1 PAn *sepsep 'to sip', Pazeh *zezeb*, Paiwan *teptep*, Rukai (Budai) *θepeθepe*, Bunun *supsup*

2 PAn *susu 'female breast', Thao *tutu*, Bunun *susu*, Proto-Rukai **θoθo*, Paiwan *tutu*

3 PAn *isa 'one', Kavalan *issa*, Rukai (Budai) *iθa*, Paiwan *ita*, Tagalog *isa*, Bikol *isa*

B. PAn *s > Proto-Rukai *s:

1 PAn *saleŋ 'pine tree', Atayal *hayuŋ*, Thao *tarin*, Bunun *saay*, Tsou *sroŋə*, Saaroa *alhəŋə*, Kanakanavu *a[əŋə*, Rukai (Maga) *ɣrəŋə*, Rukai (Mantauran) *a[əŋə*, Paiwan *taleŋ*.

2 PAn *liŋeqeS 'nit, egg of a hair louse', Saisiyat *biŋʃiŋ*, Kavalan *Risis*, Proto-Rukai **a[isəəsə*, Rukai (Budai) *a[isəəsə*, Paiwan *liŋeqes*.

¹³ See Ross (2012):1317.

whereas Proto-Rukai underwent only one major sound change, *q > zero. This clearly distinguishes Rukai from the former, and suggests separate treatments of these two language groups.¹⁴

6.2.3.3 *The position of Atayalic*

The third divergence between Ho (1998) and Blust (1999) lies in the position of the Atayalic language group, which unambiguously consists of Atayal and Seediq. In Blust (1999), Atayalic constitutes an individual primary branch, whereas in Ho (1998), it is placed under a Pazeh-Saisiyat-Atayalic branch, defined by the merger of PAn *d/D.

The validity of *d/D merger as a subgrouping criterion goes back to a longstanding question in Austronesian linguistics: whether subsets of *d should be reconstructed to Proto-Austronesian (see, e.g. Dahl 1976; Mahdi 1996; Blust 1999; Blust 2009[2012]; Ross 2012). The motivation of reconstructing multiple PAn *d comes from two distinct sources. The first is an otherwise unexplained split of *d in Paiwan and Puyuma (see (9)). The second is associated with a split of *d in word-final position in several Western Indonesian languages (Dempwolff 1937; Dahl 1976), which has generally been abandoned for PAn-level reconstruction.¹⁵

A PAn *d/D distinction is thus motivated only by evidence from Paiwan and Puyuma, where reflexes of *d unconditionally appear as *dr* (D)/*dj/z* and *dr/d*, respectively.¹⁶ This observation has received different treatments in the literature. As Paiwan and Puyuma are geographically adjacent Blust (1999:47) considers their splits of *d a product of borrowing. Tsuchida (1976), Ho (1998), and Ross (2012), on the other hand, assume these splits as reflecting to two distinct PAn phonemes.

Crucially, positing a PAn *d/D distinction entails a necessary assumption, that this distinction has been lost in all Austronesian primary branches except Paiwan and Puyuma. A Pazeh-Saisiyat-Atayalic branch based on this merger is therefore negatively defined, as it is found in all Austronesian

¹⁴ The weakness of the Rukai-Tsouic proposal lies not only in its lack of phonological evidence, but also the morphosyntactic discrepancies between Rukai and the Tsouic languages. A striking feature of Rukai is its lack of the Philippine-type syntax, which distinguishes it from all other higher-order Austronesian languages. Although this morphosyntactic difference between Rukai and Tsou does not necessarily undermine a Rukai-Tsouic branch, there is no reason to favor it.

¹⁵ According to Blust (2012:606), at least 26 comparisons support the reconstruction of word-final *-D. Several instances are presented below (cf. ACD; Blust 2009[2012]:606):

- 1 PMP *siDsiD ‘sail along the coast’, Cebuano *sidsid*, Maranao *sisid*, Malay *pe-sisir*, Bahasa Indonesia *sisir*.
- 2 PMP *bayaD ‘pay’, Ilokano *bayaḍ*, Ifugaw *bayaḍ*, Malay *bayar*, Javanese *bayar*, Sundanese *bayar*.
- 3 PWMP *sabeD ‘barrier’, Tagalog *sabid*, Cebuano *sabud*, Iban *sabar*, Malay *sawar*, Toba Batak *sabor*.

¹⁶ The unconditioned splits of PAn *d in Paiwan and Puyuma are exemplified below (cf. Ting 1976; Ho 1978):

- 1 PAn *d: Paiwan *dj* : Puyuma *d*: PAn *danaw ‘lake’, Paiwan *djanaw*, Puyuma *danaw*
- 2 PAn *d: Paiwan *dr* : Puyuma *dr*: PAn *duSa ‘two’, Paiwan *drusa*, Puyuma *drua*
- 3 PAn *d: Paiwan *z* : Puyuma *d*: PAn *deles ‘bowstring’, Paiwan *zelet*, Puyuma *ka-dares* (Cauquelin 2015:170)
- 4 PAn *d: Paiwan *z* : Puyuma *dr*: PAn *daya ‘toward the interior’, Paiwan *zaya*, Puyuma *draya*
- 5 PAn *d: Paiwan *d* : Puyuma *dr*: PAn *deRung ‘thunder’, Paiwan *derung*, Puyuma *drerung*

languages except Paiwan and Puyuma. With no other evidence for the grouping of Atayalic with Pazeh and Saisiyat, it can be concluded that the Pazeh-Saisiyat-Atayalic branch is unsupported.

6.2.4 Interim conclusion

In this section, I have reviewed the phonological evidence for Austronesian primary-level subgrouping. By revisiting the comparative evidence responsible for each difference between Ho (1998) and Blust (1999), I concluded that Bunun, Tsouic, and Atayalic are each best analyzed as a primary branch. This is because they lack any shared innovations that would justify placing them together into a larger subgroup.

The comparison of Ho (1998) and Blust (1999) has also revealed an important implication, that there is no direct conflict among different pieces of phonological evidence for subgrouping. Although the two proposals differ in the analyses of several language groups, they show no such conflict where a language is claimed to belong to Group A based on one innovation while it is linked to Group B under another. Rather, the divergences between the two lie primarily in whether a language group should stand as a primary branch or be grouped with another. This suggests that subgrouping inferences reached by phonological evidence are generally stable and consistent, despite judgmental differences among authors.

To conclude, there appears to be no sound phonological evidence for combining any of the ten primary branches into larger groups, as argued in Blust (1999). This ten-way split suggests a rapid expansion of the Proto-Austronesian community around the coast of Taiwan.

6.3 Reconsidering Approach B: N-V homophony

In this section, I turn to Approach B, which is known as the Nuclear Austronesian hypothesis (Ross 2009), motivated by a major morphosyntactic variation among higher-order Austronesian languages. By revisiting the synchronic observation behind this analysis, I show that Approach B relies crucially on a specific diachronic analysis of the synchronic facts, whose direction of change remains unjustified so far. The main claims of the section are summarized in (18):

(18) *Main claims*

- a. The absence of a feature X in a language always allows two diachronic accounts; it can either be a *retention* or an *innovation* (i.e., *loss*).
- b. Approach B assumes that the absence of X must be a retention (i.e., *X never existed*).
- c. If the assumption in (b) is false, Approach B cannot reach reliable subgrouping conclusions.

I first revisit the synchronic observation behind Approach B in 6.3.1, and review the methodology and core assumption of this proposal in 6.3.2—3.

6.3.1 Synchronic observation

6.3.1.1 Nominalizer-voice affix homophony

Higher-order Austronesian languages can be roughly divided into two types based on whether their voice affixes in indicative clauses share the same form with the corresponding nominalizers.¹⁷ Most languages belong to the first type (henceforth Type I), where the same affixes are used bi-functionally as indicative voice marker and nominalizer, as seen in (19).¹⁸ In this type of language, the perfective marker may appear in both verbal and nominalized environments, as in (19c)-(c'). To facilitate understanding for historical linguists, I use the conventional label 'Genitive' instead of 'X' to gloss the argument marker on the external argument of non-AV clauses, which were used in Chapters 2–5.

(19) N-V homophony in Seediq

- | | | |
|-----|---|--|
| a. | k<m><n>eeki ka Dakis.
dance<AV><PRF> PIVOT Dakis
'Dakis danced.' | <m> as actor voice affix (< PAn *<um>) |
| a'. | k<m><n>eeki nii
dance<AV><PRF> this
'the one who danced' | <m> as agent nominalizer (< PAn *<um>) |
| b. | puq- <i>un</i> na Dakis ka sari.
eat-PV GEN(X) Dakis PIVOT taro
'Dakis will eat the/a taro.' | - <i>un</i> as patient voice affix (< PAn *-en ¹⁹) |
| b'. | puq- <i>un</i>
eat-PV.NMZ
'thing to be eaten, lexicalized as 'food'' | - <i>un</i> as patient nominalizer (< PAn *-en) |
| c. | n-huqil- <i>an</i> na rodan nii ka Paran.
PRF-die-LV GEN(X) old.man this PIVOT Paran
This old man died in Paran.' | - <i>an</i> as locative voice affix
(< PAn *-an) |

¹⁷ The term 'nominalizer' is conventionally used in the Austronesian literature, referring to the affixal morphology on the predicate in nominalized environments, most commonly in relative clauses or the presupposed clause of pseudo clefts, which are standardly analyzed as headless relative clauses (Potsdam 2006). To keep the discussion concise, I follow this convention here and call the affixal morphology in relative clauses nominalizers. See Chapters 5 and 7 for further discussion.

¹⁸ As this statement implies, in conservative Philippine-type languages, voice affixes inflect for mood and distinguish among indicative and several non-indicative moods (imperative and optative). See Chapter 7 for more details.

¹⁹ Under the Nuclear Austronesian hypothesis, whether the Patient voice affix *-en can be reconstructed to Proto-Austronesian-level is controversial, as reflexes of *-en are attested only in one of the four primary branches. See Chapter 7 for a discussion.

- c'. *n-huqil-an* -an as locative nominalizer
PRF-die-LV.NMZ (< PAN *-an)
 'place of death'
- d. *s-uuyas na riso nii ka mayku.* s- as circumstantial voice affix
CV-sing GEN(X) young.man this PIVOT microphone (< PAN *Si-/Sa-)
 'This young man sang with a/the microphone.'
- d'. *s-uuyas* s- as circumstantial nominalizer
CV.NMZ-sing (< PAN *Si-/Sa-)
 'instrument used to sing'

As seen above, each of the four voice affixes in Seediq is homophonous with its corresponding nominalizer. For instance, the Patient voice verb *puq-un* 'eat' shares the form *-un* with the patient nominalizer in the nominal *puq-un* 'thing to be eaten, food' (19a)-(b').²⁰ This phenomenon is found across higher-order Austronesian languages and regarded as a core trait of the Philippine-type voice system, which I refer to as *nominalizer-voice affix (N-V) homophony*.

Importantly, these bi-functional affixes in different languages can be traced back to a common origin: AV **<um>*, PV **-en*, LV **-an*, CV **Si-/Sa-*, and the perfective marker **<in>*, suggesting that their form and function had already been fixed at a proto-stage.²¹ To remain analysis neutral, I refer to these primary affixes as *Set A affixes*, which is equivalent to the term *second generation affixes* used in previous work.

6.3.1.2 The absence of N-V homophony in Rukai, Tsou, and Puyuma

Exceptions to this observation were first recognized in Ross (2009), which identified three Formosan languages that do not show N-V homophony: Rukai, Tsou, and Puyuma (henceforth Type II).

The absence of N-V homophony in these languages is manifested in three ways. Rukai lacks N-V homophony simply because it employs no voice alternation in root clauses. On the other hand, it employs two nominalizers, locative nominalizer *-an* and circumstantial nominalizer *sa-*, which are reflexes of the Set A affix LV **-an* and CV **Sa-*. As both are used exclusively as nominalizers, Rukai shows no N-V homophony.

Tsou and Puyuma each exhibit a Philippine-type four-way voice system, yet employ a set of 'noncanonical' voice affixes that are etymologically distinct from the Set A affixes. As shown in

²⁰ Under the analysis presented in Chapter 5, these nominals are structurally a headless relative clause. Many of them have been lexicalized and used as common nouns, for instance:

- 1 Seediq *puq-un*/Puyuma *akan-en* 'food' ('eat' + patient nominalizer *-un/-en* = 'thing to be eaten'),
- 2 Pazih *sa-kita* 'glasses' (instrumental nominalizer *sa-* + 'see' = 'thing used to see'),
- 3 Puyuma *da-deru-an* 'cooking pot' (Ca-reduplication + 'cook' + locative nominalizer *-an* = 'location where cooking took place')

²¹ As existing proposals disagree in the chronology of N-V homophony, I remain open on this question at this point. Relevant discussion and analysis can be found in Chapter 7.

(20), the non-Actor voice affixes used in Puyuma's root clauses (PV *-aw*, LV *-ay*, CV *-anay*) are formally distinct from those in Seediq (PV *-un*, LV *-an*, CV *s-*) (19). On the other hand, Puyuma exhibits a set of nominalizers (PV *-en*, LV *-an*, CV *i-*) that are reflexes of the Set A affixes, as seen in (20a')-(d'):²²

(20) *The absence of N-V homophony in Puyuma*

- | | |
|--|--|
| <p>a. senay=ku (dra senay).
sing<AV>=1SG.PIVOT (ID.ACC(Y) song)
'I sang (a/the song).'</p> | <p>Actor voice affix (< PAn *-um-)</p> |
| <p>a'. na senay (dra senay)
DF.PIVOT sing<AV> (ID.ACC(Y) song)
'the one who sang (a/the song)'</p> | <p>Agent nominalizer (< PAn *-um-)</p> |
| <p>b. ku=ekan-aw na bu'ir.
1SG.GEN(X)=eat-PV PIVOT taro
'I ate taro.'</p> | <p>Patient voice affix <i>-aw</i> (< PAn *-aw)</p> |
| <p>b'. akan-en
eat-PV.NMZ
'food, things to be eaten'</p> | <p>Patient nominalizer <i>-en</i> (< PAn *-en)</p> |
| <p>c. ku=pubini-ay dra bini na uma'.
1sg.GEN(X)=sow-LV ID.ACC(Y) seed DF.PIVOT field
'I sow seeds in the field.'</p> | <p>Locative voice affix <i>-ay</i>
(< PAn *-ay)</p> |
| <p>c'. p<in>ubini-an
sow<PRF>LV.NMZ
'place that has been sowed (with seeds)'</p> | <p>Locative nominalizer <i>-an</i>
(< PAn *-ay)</p> |
| <p>d. tu=beray-anay kanku na aputr.
3.GEN(X)=give-CV 1SG.ACC(Y) DF.PIVOT flower
'He/she gave me flowers.'</p> | <p>Circumstantial voice affix <i>-anay</i>
(< PAn *-anay)</p> |
| <p>d'. i-ba-beray
CV.NMZ-CA.RED-give
'the one who was given something'</p> | <p>Circumstantial nominalizer <i>i-</i>
(< PAn *Si-/Sa-)</p> |

The correspondence of the primary affixes used in these languages is summarized in (21). As seen below, the non-Actor voice affixes in Puyuma (21c) and Tsou (21d) are etymologically distinct from those in Type I languages (18a). On the other hand, the nominalizers in Puyuma and Rukai

²² Tsou also employs a set of 'noncanonical affixes' (PV *-a*, LV *-i*, CV *-(n)eni*) cognate with those in Puyuma (PV *-aw*, LV *-ay*, CV *-anay*). This set of 'noncanonical' primary affixes are used in both verbal and nominalized environments in Tsou, which differ from those in Puyuma and Rukai. To keep the discussion simple, I skip details about Tsou at this point and will revisit them in Chapter 7.

(21b)-(c) are cognate with the bi-functional Set A affixes in Type I languages. Tsou is clearly aberrant, as it reflects no trace of the Set A affixes in non-Actor voices (21d).

(21) TABLE 6.8. Morphological paradigms in Rukai, Tsou, Puyuma, and prototypical languages

		Actor voice		Patient voice		Locative voice		Circumstantial voice	
		V	N	V	N	V	N	V	N
Type I	a. majority	*M-	*M-	*-en	*-en	*-an	*-an	*Si-/Sa-	*Si-/Sa-
Type II	b. Rukai	m-	m-/ta-	—	(-en)	—	-an	—	sa-(<*Sa-)
	c. Puyuma			-aw	-en	-ay	-an	-anay	i- (<*Si-)
	d. Tsou	m(o)-	ta-	-u	-a	-i	-i	-(n)eni	-(n)eni

As these languages are all genetically related, their variation must derive from a single, unitary proto-type.²³ In what follows, I outline several possible accounts for the derivational pathway of the variation, and discuss the approach taken by Approach B.

6.3.2 Approach B and the Nuclear Austronesian Hypothesis revisited

In principle, the variation in (21) allows two diachronic interpretations: (a) the lack of N-V homophony reflects the prototype, or (b) the presence of N-V homophony reflects the prototype. Under (a), the lack of N-V homophony in Rukai, Tsou, and Puyuma is a *retention*, and the presence of N-V homophony is an *innovation*, as in (22a). Under (b), the majority of higher-order languages (Type I languages) are *retentive*, and the absence of N-V homophony in Rukai, Tsou, and Puyuma is *innovative*, as in (22b). Both directions of change are logically possible and would yield the same synchronic variation.

²³ The Type I morphology shown in (18a) reflects Ross's (2012) reconstruction of Proto-Nuclear Austronesian, which represents the common morphological traits of conservative Philippine-type languages. Sources of the table are listed as follows: Puyuma: Tsuchida (1980); Teng (2008, 2009); Chen f.n.); Rukai (Zeitoun 2000b, 2007; Ross 2012); Tsou (Zeitoun 2000c; Ross 2012).

(22) FIGURE 6.9. Two interpretations of the discrepancy in N-V homophony

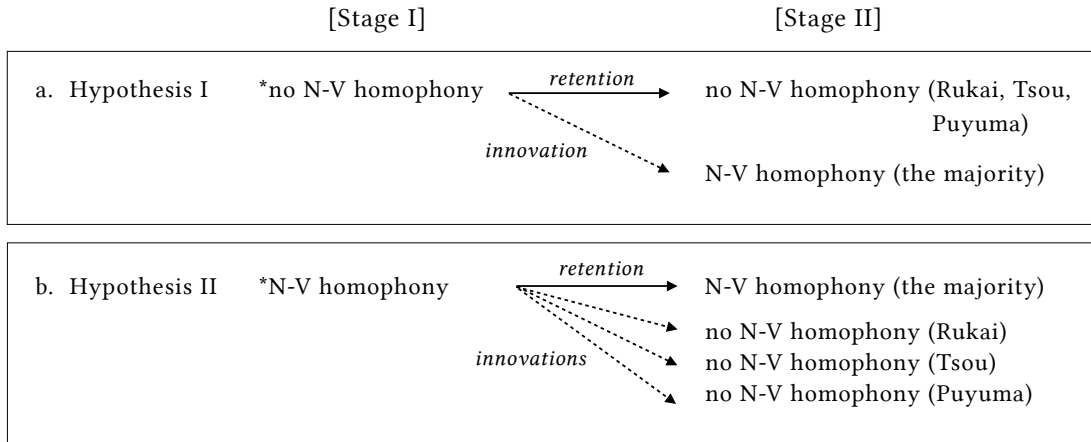

6.3.2.1 The four-branch subgrouping under Approach B

Ross (2009) and subsequent work has argued for the scenario in (22a) (Ross 2012; Aldridge 2014, 2016; Zeitoun & Teng 2014, 2016), assuming that the synchronic N-V homophony in Type I languages arose from an archaic innovation *Nominalization-into-verb* (*Nom-into-V*) (Starosta, Pawley, & Reid 1982), which reanalyzed a set of nominalizers into their functionally equivalent verbal affixes (i.e. voice affixes), as illustrated in (23):

(23) FIGURE 6.10. The purported evolutionary pathway of N-V homophony

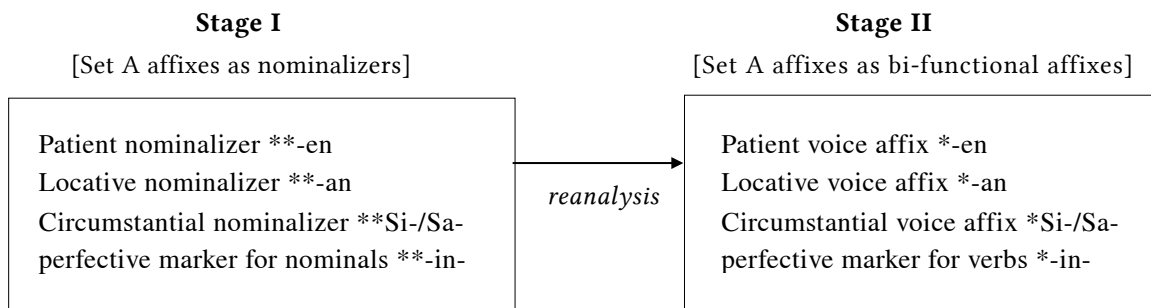

Following (23), Ross attributes the lack of N-V homophony in Rukai, Tsou, and Puyuma to their being excluded from the purported reanalysis of *Nom-into-V*, assuming that the exclusive nominalizer use of Set A affixes in Rukai and Puyuma (see (21b)-(c)) reflects the proto-system prior to reanalysis. As Rukai, Tsou, and Puyuma do not share any obvious innovation, each is considered a single-member primary branch. All other languages are placed under a fourth branch, *Nuclear Austronesian*, defined by the purported innovation of *Nom-into-V*, as in (24). This analysis is thus known as the *Nuclear Austronesian (NAN) hypothesis*.

(24) FIGURE 6.11. Austronesian primary-level subgrouping under the NAn hypothesis

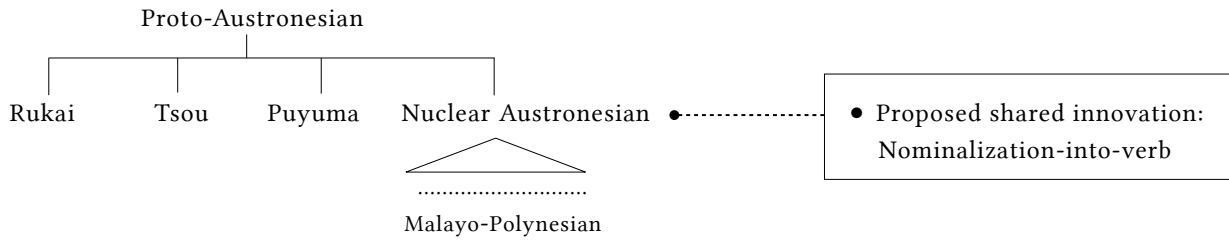

6.3.2.2 Recent refinements of the Nuclear Austronesian hypothesis

Recent findings in two Formosan languages have motivated further divisions within the Nuclear Austronesian branch. According to Zeitoun & Teng (2014, 2016), in Saaroa, only one of the Set A affixes, the perfective marker *lhi-* (reflex of PAN *<in>), is used bi-functionally as voice affix and nominalizer, while the rest of the Set A affixes are used exclusively as nominalizers. In Kanakanavu, only two of the Set A affixes, the perfective marker <*in*> (reflex of Pan *<in>) and the PV affix *-un* (reflex of PAN *-en), are used bi-functionally, with the other two Set A affixes (LV and CV) used exclusively as nominalizers.²⁴

To accommodate the Nom-into-V hypothesis with these two languages' partial realization of N-V homophony, Zeitoun & Teng (2016) propose that the reanalysis of Nom-into-V developed in a step-by-step manner, in the order *perfective marker* > *patient nominalizer* > *locative/circumstantial nominalizers*. It is claimed that Saaroa and Kanakanavu split off from the proto-language at different stages prior to the completion of the Nom-into-V reanalysis, as in (25):

²⁴ The morphological paradigms of the two languages are presented below. According to Teng & Zeitoun (2016), Saaroa lacks locative voice in root clauses, exhibiting only a three-way voice distinction in its root-clause morphology (a); Kanakanavu lacks both the Locative and Circumstantial voices with only a two-way voice distinction (b):

a. Saaroa					
	Agent nmz	Theme nmz	Locative nmz	Circumstantial nmz	
"Nominalizer"	?	√-a(na), <i>lhi</i> -√	ta-√-a(na)	si-√, √-ani	
Voice affix	Actor voice	Patient voice	Locative voice	Circumstantial voice	
... Indicative	<i>M</i> -√	√-a	—	√-ani	
... Imperative	<i>M</i> -√-a	√-u	—	√-ani	
... Dependent	<i>M</i> -√	√-i	—	√-i	
b. Kanakanavu					
	Agent nmz	Theme nmz	Locative nmz	Circumstantial nmz	
"Nominalizer"	ta-, <i>M</i> -	√-an, < <i>in</i> >√	ta-√-an	si-√	
Voice affix	Actor voice	Patient voice	Locative voice	Circumstantial voice	
... Indicative	<i>M</i> -√	√-un, < <i>in</i> >√	—	—	
... Imperative	<i>M</i> -√-a	√-(a)u	—	—	
... Dependent	<i>M</i> -√	√-(a)i	—	—	

(25) FIGURE 6.12. The purported ordering of the Nominalization-into-verb innovation

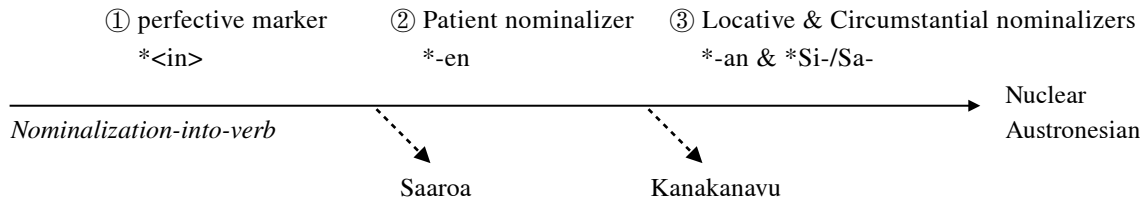

As shown above, it is proposed that Saaroa split off from the proto-language after the reanalysis of the perfective marker **<in>* into a verbal affix, and Kanakanavu split off after the reanalysis of the patient nominalizer **-en*. The last step of the Nom-into-V innovation is assumed to reanalyze the locative and circumstantial nominalizers into their corresponding voice affixes, which defines a Nuclear Austronesian subgroup, characterized by full N-V homophony. As the term *Nuclear Austronesian* now refers to the internal subgroup at the bottom of this primary branch, I refer to this as the “*Nom-into-V*” branch in the following discussion.

Under (25), Saaroa is analyzed as the first offshoot, defined by the purported reanalysis of the perfective marker *lhi-* (**<in>*) into a verbal affix; Kanakanavu is analyzed as the second off-shoot, defined by the innovation of the patient nominalizer **-en* into the patient voice affix. The rest of the languages are placed at the bottom, defined by the putative innovations of the locative and circumstantial nominalizers into voice affixes, as in (26):

(26) FIGURE 6.13. Revised Austronesian primary-level subgrouping under Approach B

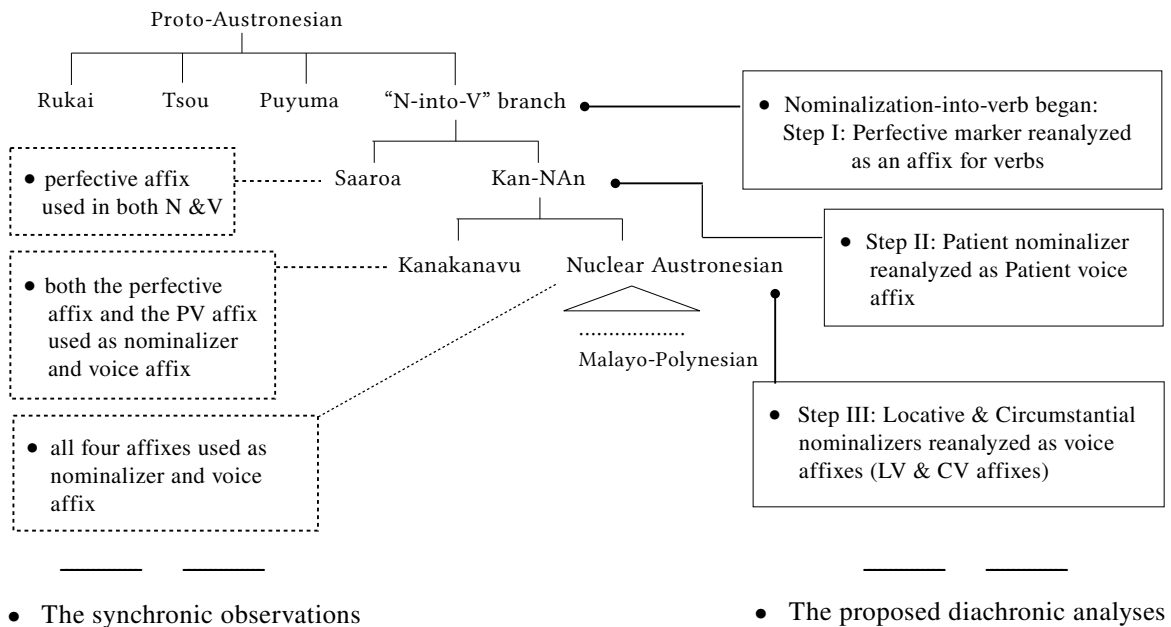

6.3.3 Interim summary

In sum, proposals following Approach B share a core assumption: *the synchronic absence of a feature indicates that it has never existed in the language*. However, as discussed in 6.3.2, this is not the only diachronic analysis that can account for the synchronic variation. The validity of this subgrouping therefore relies critically on the validity of this diachronic interpretation—which has remained unjustified in previous works. This approach will be further examined in Chapter 7.

6.4 Reconsidering Approach C: Ergativity

In this section, I turn to Approach C, which is motivated by another type of morphosyntactic variation among higher-order Austronesian languages. I start with a summary of relevant synchronic facts in 6.4.1, and review the methodology of this approach in 6.4.2–3.

6.4.1 The synchronic facts

The lack of Philippine-type syntax in Rukai has been of interest to many researchers, especially for those interested in the historical derivation of the Philippine-type voice system (e.g. Starosta 1985, 1995; Aldridge 2014, 2016). Rukai is conventionally regarded as exhibiting a simple active-passive system, as in (27):²⁵

(27) *Active-passive contrast in Rukai*

- | | | | | | | | |
|----|--|-----------|-------|-------|--------|-----------------|-----------------|
| a. | w-a-kane | ku | babuy | ka | cumay. | [Active voice] | |
| | ACT-IMPFV-eat | ACC | boar | NOM | bear | | |
| | 'The bear ate a boar.' | | | | | | |
| b. | ki-a-kane | ki | cumay | ka | babuy. | [Passive voice] | |
| | PASS-IMPFV-eat | OBL | bear | NOM | boar | | |
| | 'The boar was eaten by a bear.' | | | | | | |
| c. | ki-a-bay | (nakuane) | ki | cegaw | ka | Laimay. | [Passive voice] |
| | PASS-IMPFV-give | (1.OBL) | OBL | Cegaw | NOM | clothes | |
| | 'The clothes were given to Cegaw (by me).' (Chen C.-F. 2005:36,42) | | | | | | |

In active sentences in Rukai (27a), the agent bears the marker *ka*, which is commonly analyzed as nominative. In passives (27b)-(c), the 'demoted' agent receives a distinct marking *ki* and can be optionally omitted (27c), showing typical behavior of a *by*-phrase.

²⁵ However, I will argue in Chapters 8—9 that Rukai in fact exhibits a remnant Philippine-type voice system with an AV/PV distinction plus a passive voice, following a previous claim by Chen C.-F (2005).

Previous work has argued for (29a), assuming that the synchronic system of Rukai directly reflects Proto-Austronesian. Under this assumption, Starosta (1985, 1995) has analyzed Rukai as the first offshoot of Proto-Austronesian, which split off prior to the purported emergence of the Philippine-type voice system, as in (30):

(30) FIGURE 6.15. Subgrouping proposal under (29a)

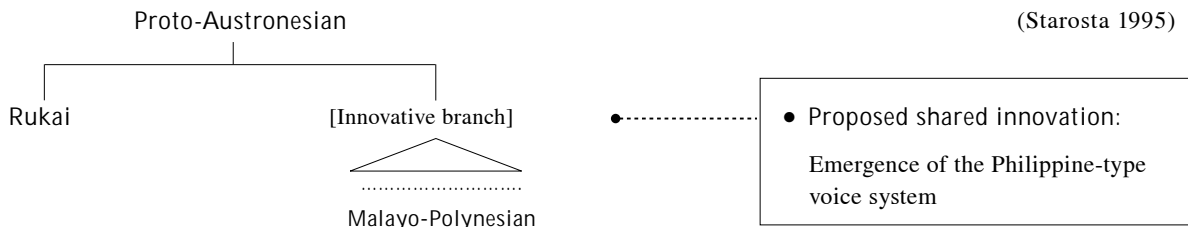

Based on the assumption that Philippine-type voice systems are ergative, recent work by Aldridge (2014, 2016) further argues that the Austronesian family underwent a binary split, defined by the emergence of ergativity. According to this analysis, the Philippine-type voice system arose from an archaic innovation, which reanalyzed irrealis clauses with low transitivity into root clauses, giving rise to ergativity. This putative reanalysis defines an innovative primary branch, *Ergative Austronesian*, which contains all Austronesian languages except Rukai, as in (31):

(31) FIGURE 6.16. Subgrouping proposal under Approach C

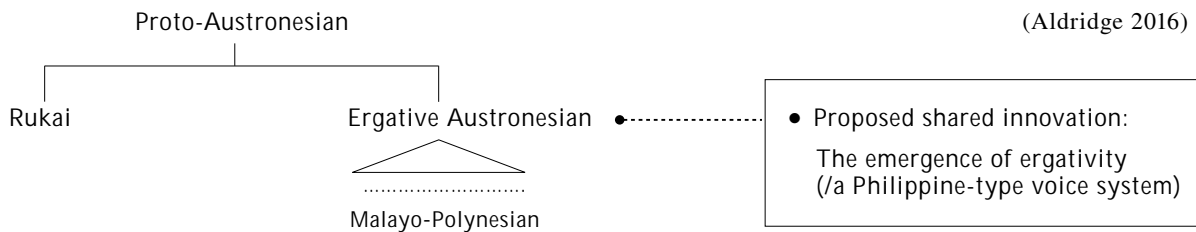

6.4.3 Interim summary

In brief, Approach C shares a similar diachronic interpretation with Approach B, that *the synchronic absence of a feature X entails that X never existed in the history of the language*. In addition, it is founded on a specific synchronic analysis that Philippine-type languages exhibit ergativity. The validity of this approach thus relies critically on the reliability of these two assumptions, which will be revisited in Chapter 7.

6.5 Conflicts among Approaches A, B, and C

I have argued in the preceding sections that the reliability of Approaches B and C awaits examination, as both are founded on specific diachronic analyses that allow other alternatives. In this section, I show that both are in conflict with other types of evidence for subgrouping. I begin by identifying four major conflicts among the three approaches, and outline possible accounts for them.

6.5.1 Conflict 1: The validity of Tsouic

A major issue in Approach B is its incompatibility with the Tsouic branch. As discussed in Section 6.2, based on phonological evidence, Tsou, Saaroa, and Kankananavu constitute a Tsouic branch, as in (32a). However, under Approach B, the three languages are separated into three different levels under two primary branches, as in (32b).

(32) FIGURE 6.17. The validity of Tsouic

a. Approach A

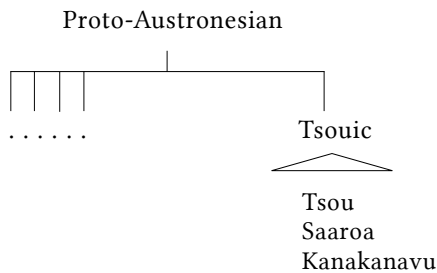

b. Approach B

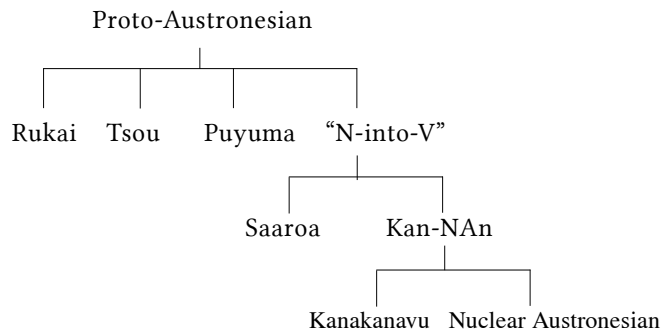

The conflict between Tsouic and the subgrouping defined by the Nom-into-V reanalysis is nontrivial, given the strength of the evidence that defines the former. In what follows, I discuss three types of evidence for Tsouic.

6.5.1.1 Tsouic: Phonological and lexical evidence

Phonologically, Tsou, Saaroa, and Kankananavu share four innovations: mergers of Proto-Austronesian *g/k, *j/Ø, *S/s, and *R/r (Tsuchida 1976). While the former three are not exclusively shared by the three languages, the merger of *R/r is a rare change among highest-order Austronesian languages (see (11)), and thus constitutes a solid subgrouping criterion.

Besides phonological evidence, the three languages exclusively share 57 apparent lexical innovations, some of which are replacements of their Proto-Austronesian equivalents (Tsuchida 1976). See a sample list in (33):²⁷

(33) *Sample of exclusively shared lexical innovations among Tsou, Saaroa, and Kanakanavu*

Proto-Austroneian	Proto-Tsouic	gloss	language
*esa/isa	*cáni	‘one’	T/S/K
*biCuka	*Civuka	‘belly’	T/S/K
*benan	*walúwálu	‘white-spotted deer (<i>Cervus taiouanus</i>)’	T/S/K
*biRaḡ	*cálúhu	‘inedible taro (<i>Alocasia macrorrhiza</i>)’	T/S/K
*kaka	*kałálúã	‘older sibling’	T/S/K
*qenay	*lavúku	‘sand’	T/S/K
*Canem	*ləməkə	‘to plant’	T/S/K
*sulaR	*vułáyí	‘snake’	T/S/K

This shared vocabulary is difficult to account for as loans, as basic words are unlikely to be borrowings, including the numeral ‘one’, body parts, and kinship terms (33). Especially because Saaroa and Kanakanavu are considered two distinct subgroups under the “Nom-into-V” branch (Zeitoun & Teng 2016, see Section 6.3.3), a borrowing analysis requires very complicated assumptions, as follows: (i) each shared item was a result of two independent borrowings between Tsou and Saaroa and Tsou and Kanakanavu, and (ii) each could reflect a borrowing between Tsou and Proto-“Nom-into-V”, which was inherited by both Saaroa and Kanakanavu and lost in Nuclear Austronesian. The former account is highly unlikely, and the latter appears untenable, as many Nuclear Austronesian languages have cognates of these vocabulary items, which disproves this proposal. These lexical innovations therefore stand as strong evidence for a Tsouic branch.

6.5.1.2 *Tsouic: Nonlinguistic evidence*

Besides linguistic evidence, Ferrell (1969) has identified Tsou, Saaroa, and Kanakanavu as belonging to the same culture group, based on the shared sociocultural features summarized in (34). Importantly, while Saaroa and Kanakanavu have been under extensive influence by the areally dominant Bunun (Tsuchida 1976; Pan 2013; Wild 2017), their sociocultural features share little similarity with Bunun but show a tight connection with Tsou, indicating a probable shared origin with the latter.

²⁷ See also a relevant discussion in Sagart (2014).

(34) TABLE 6.10. Shared sociocultural features among Tsou, Saaroa, and Kanakanavu

	Material culture	Religion and oral tradition	Communities
Tsou culture	<ul style="list-style-type: none"> • No stone-carving and decorative wood • Manufactured pottery; leather used for clothing; bark container • Unique Tsouic style house • Men’s meeting house 	<ul style="list-style-type: none"> • Particularized named gods and spirits (contra. Atayal and Bunun Cultures) • Originated in Yushan, and later split into Northern Tsou and Southern Tsou. Southern Tsou moved down along Laonung River and further split into Saaroa and Kanakanavu (Li 2001a:273) 	Tsou, Saaroa, Kanakanavu

To conclude, phonological, lexical, and sociocultural evidence favor a Tsouic branch. Any conflicting subgrouping proposal should therefore be treated with caution. This conclusion reveals an interesting fact, that the morphosyntactic difference between Tsou and the other two Tsouic languages contradicts their many similarities in other aspects. This calls for a reconsideration of the nature of Austronesian N-V homophony as well as its absence in Tsou.

6.5.2 Conflict 2: “Nom-into-V”: The phonological non-evidence

A second issue in Approach B concerns its lack of empirical support. While three of its four primary branches underwent phonological changes from Proto-Austronesian (35b)-(c), the purported Nom-into-V branch and its internal subgroup Nuclear Austronesian show no phonemic difference from Proto-Austronesian (35a)-(a’):

(35) TABLE 6.11. The phoneme inventories of higher-order branches under the NAn hypothesis

Proto-Austronesian	*p	*t	*C	*k	*q	*b	*d	*z	*j	*g	*m	*n	*N	*ñ	*ŋ	*s	*S	*l	*r	*R	*h
a. Proto-“N-into-V”	*p	*t	*C	*k	*q	*b	*d	*z	*j	*g	*m	*n	*N	*ñ	*ŋ	*s	*S	*l	*r	*R	*h
a’. Proto-NAn	*p	*t	*C	*k	*q	*b	*d	*z	*j	*g	*m	*n	*N	*ñ	*ŋ	*s	*S	*l	*r	*R	*h
b. Tsou	p	t	c	ʔ,k	∅	f	c	c	∅	k	m	n	n	h,k	ŋ	s	s	l	r	r	∅
c. Proto-Rukai	p	t	c	k	∅	b	dr	d	g,∅	g	m	n	--	l	ŋ	s	s	lr	lr	--	∅
d. Proto-Puyuma	p	t	tr	k	ʔ	b	d,dr	d	d	h	m	n	l	l	ŋ	s	s	∅	lr	r	ʔ

Besides the absence of phonological evidence, there is also no known lexical innovation or sociocultural feature that defines either a “Nom-into-V” or Nuclear Austronesian branch.²⁸ supporters of Approach B would therefore need to assume that Nom-into-V was the only innovation that occurred before the “Nom-into-V” branch split into further subgroups. A possible account for this is a

²⁸ See 6.6.3.2 for Ferrell’s (1969) sociocultural classifications of the Formosan aborigines.

scenario of rapid splits. This explanation, however, contradicts Zeitoun & Teng's (2016) proposal that the Nom-into-V reanalysis developed in several stages, long enough for two subgroups to split off. It can thus be concluded that the Nuclear Austronesian hypothesis is founded on a single, purported innovation.

6.5.3 Conflict 3: The status of Rukai and Tsou

A third controversy among the three approaches lies in their inferences of Rukai and Tsou. Two major questions are discussed as follows.

6.5.3.1 *Rukai: Innovative or retentive?*

Under Approaches A and B, a Philippine-type voice system can be reconstructed to Proto-Austronesian, as the majority of their primary branches contain Philippine-type languages.²⁹ The absence of such a voice system in Rukai is therefore inferred to be a result of loss under these two approaches. Approach C, however, analyzes the Philippine-type voice system as a secondary development, according to which Rukai reflects the archaic system of Proto-Austronesian. The outlier-like morphosyntax of Rukai thus receives two opposite interpretations.

6.5.3.2 *Rukai first or Tsou first?*

Further, Approaches B and C diverge in their implications for the derivational ordering of Tsou or Rukai (e.g., Starosta 1985, 1995; Chang 2006; Ross 2012).

From the perspective of N-V homophony (Approach B), Tsou is more primitive than Rukai, as none of the Set A affixes—which constitute the phenomenon of N-V homophony—is found in Tsou (see (18)). These primary affixes were therefore inferred as a secondary development after Tsou split off from Proto-Austronesian. In this view, Tsou is the first offshoot of the Austronesian family.³⁰ Under Approach C, however, Rukai is the most primitive, on the assumption that it split off before the emergence of the Philippine-type voice system.

This controversy reveals that subgroupings founded on specific diachronic analyses of different synchronic facts may be mutually incompatible, suggesting a need to reexamine their validity.

²⁹ This reconstruction is strongly favored by parsimony. If a Philippine-type system is not reconstructed to PAn, the presence of the voice system needs to be explained as an independent innovation in every primary branch.

³⁰ An alternative account is to assume that Tsou has lost these affixes independently. However, given the logic of the Nuclear Austronesian hypothesis, which assumes that the absence of X entails that X never existed, the chronology of these primary affixes must be analyzed in this way.

6.5.4 Conflict 4: Divergences in homeland inferences

Finally, Approaches A, B, and C diverge in their homeland inferences.

Ross (2012) has argued that the earliest reconstructable homeland of Austronesian was the southern highlands of Taiwan. This proposal is based on the *Linguistic Migration theory* (Sapir 1916; Dyen 1956; Diebold Jr. 1960; Nichols 1997), which argues that the geographic area with greatest linguistic diversity is the most likely linguistic homeland. As three of the four primary branches under Approach B (Rukai, Tsou, and Puyuma) are distributed around the southern highlands of Taiwan, this area is regarded as the Austronesian homeland (Ross 2012:1320). This hypothesis is additionally supported by Zeitoun & Teng’s revised proposal (31b), as the two internal subgroups of the “Nom-into-V” branch (Saaroa and Kanakanavu) are also located in this region, as in (32b).

Approach C points to a similar hypothesis, as Aldridge (2016) adopts the Nom-into-V hypothesis to define its internal subgroups, according to which Tsou and Puyuma as two secondary-level offshoots (see Chapter 7). As these two languages and Rukai are all situated in the southern highlands, Approach B shares a similar homeland inference with Approach B (36c).

On the other hand, the phonology-based subgrouping suggests no obvious center of dispersal of the Austronesian family, as nine of its ten primary branches are distributed in different regions of Taiwan, indicating a rake-like distribution of the Austronesian’s early settlement in Taiwan, as in (36a).

(36) FIGURE 6.18. Homeland inferences under Hypotheses A, B, and C

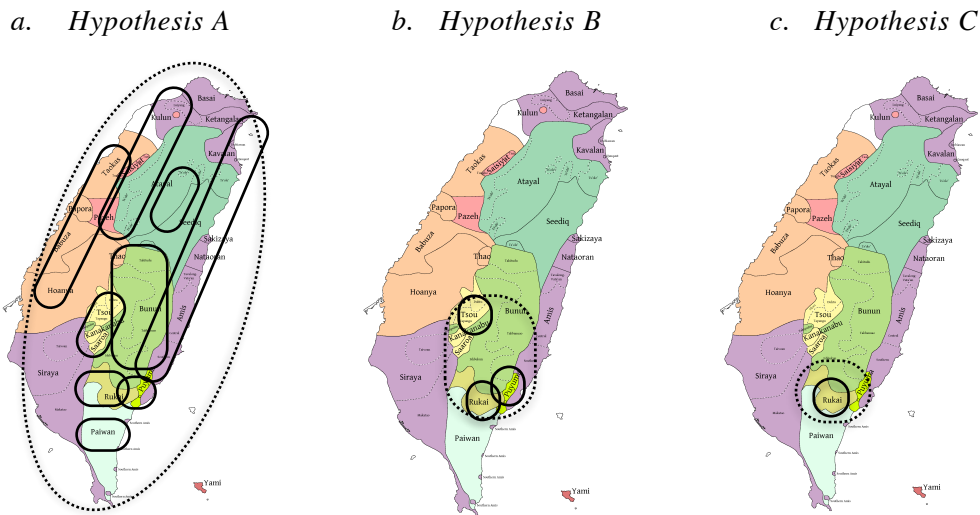

To summarize, the homeland implied by the phonology-based subgrouping, namely one in which the entire coast of Taiwan was settled before any movement to the interior, disagrees sharply with the homeland implications of the higher-level subgroupings based on proposed morphosyntactic innovations. Given these disagreements between arguments based on language, the

next thing we need to do is to compare the homelands implied by each of these subgrouping theories with the independent evidence of archeology to determine degrees of compatibility. This will be done in 6.6.3.1.

6.5.5 Summary of the conflicts

To summarize, Approaches A, B, and C show four major conflicts, as in (37):

(37) TABLE 6.12. Summary of the conflicts among Approaches A, B, and C

	Approach A	Approach B	Approach C
	phonological & lexical evidence	discrepancy in N-V homophony	discrepancy in the voice system
a. a Tsouic branch	✓	✗	—
b. the status of Rukai	<i>innovative</i>	<i>innovative</i>	<i>retentive</i>
c. a “Nom-into-V” branch	<i>no evidence</i>	✓	—
d. homeland inferences	<i>no obvious homeland</i>	<i>southern highlands</i>	<i>southern highlands</i>

As seen in (37), these three approaches are not mutually compatible. Approaches A and B agree regarding the morphosyntactic history of Rukai, but differ in their homeland inferences. On the other hand, Approach C disagrees with both in assuming a Proto-Austronesian system with no voice distinction. In the following section, I explore the strength of each approach.

6.6 Evaluations

In this section, I present an evaluation of the three approaches, and show that Approach A is optimal given its agreement with other types of evidence for subgrouping. Each approach is evaluated in three ways: 1) methodological soundness (6.6.1), 2) compatibility with the analyses from the first half of the dissertation (6.6.2), and 3) compatibility with two types of nonlinguistic inferences for subgrouping (6.6.3).

6.6.1 Methodological soundness

It has long been acknowledged that phonological changes in general follow more a predictable directionality than morphosyntactic innovations (see, e.g. Jeffers 1976; Winter 1984; Juge 2002; Lightfoot 2002). Phonological innovations therefore constitute a more reliable means for

subgrouping, as “there is less well-founded basis for claiming that grammars change in one direction but not in another” (Lightfoot 2002:126).

As pointed out in the preceding discussion, the reliability of Approaches B and C involves a number of unjustified assumptions, ranging from the validity of the diachronic analysis to the accuracy of the synchronic analysis on which the proposals are based. Without justifications for these assumptions, subgrouping proposals built on these approaches are indeterminate.

In addition, a potential shortcoming of subgroupings based on apparent morphosyntactic innovations lies in their methodological inconsistency. As acknowledged in Ross (2009, 2012), the internal subgrouping of the Nuclear Austronesian hypothesis relies on phonological innovations. This treatment reveals a nontrivial issue: while the Nuclear Austronesian proposal makes use of phonological evidence for lower-level subgrouping, where a phonological innovation contradicts the proposed morphosyntactic innovation (31a)-(b), it is disregarded.

It can thus be concluded that Approaches B and C suffer from several methodological shortcomings that compromise their usefulness.

6.6.2 Compatibility with the proposed analyses for synchronic Austronesian syntax

I have argued in the preceding chapters that (i) a prototypical Philippine-type voice system does not exhibit ergativity at either the syntactic or morphological level (Chapters 2–4), and (ii) Austronesian N-V homophony is essentially the realization of topic-indicating morphology in verbal and nominalized environments (Chapter 5). If this analysis is on the right track, Approaches B and C are each founded on an inaccurate synchronic analysis that undermines their validity for subgrouping.

As discussed in Aldridge (2014, 2016), the Nom-into-V hypothesis relies on a conventional assumption that the Philippine-type voice affixes are reflexes of functional heads (v^0/Appl^0), which were reanalyzed from corresponding nominal heads (n^0/Appl^0) (Aldridge 2014), as in (38):

(38) *Austronesian noun/verb homophony under the Nom-into-V hypothesis*

a. *before the reanalysis*

b. *after the reanalysis*

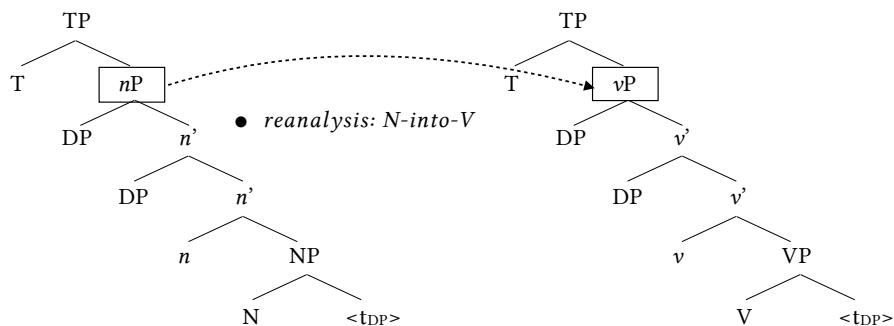

Since this conventional analysis has been shown to be untenable in Chapter 5, subgrouping approaches based on it are unreliable.

As argued in Chapter 5, the homophony between nominalizer and voice affix essentially reflects the same topic-indicating agreement in both verbal and nominalized environments—which is conventionally referred to as ‘*voice affix*’ and ‘*nominalizer*’, respectively, as illustrated in (39). Under this analysis, there is no motivation for assuming a derivational relation between nominalizers and voice affixes, as both manifest the same type of agreement hosted at C, despite their terminological difference.

(39) *The present analysis of Austronesian noun/verb homophony*

- a. ‘voice affix’: [CP TopP_[HΦP] ... C [TP V ... DP₁ DP₂_[HΦP] ...]]
- ↑-----↑
“voice affix”
- b. ‘nominalizer’: [DP D [CP TopP_[HΦP] ... C [TP V ... DP₁ DP₂_[HΦP] ...]]]
- ↑-----↑
“nominalizer”

Given the analysis in (39), N-V homophony can be seen as the prototype of the Philippine-type voice system. The purported innovation of Nominalization-into-verb is unnecessary, as there is no sound reason to assume that Proto-Austronesian was a system with only nominalized clauses. A more detailed discussion of this analysis will be presented in Chapter 7.

6.6.3 Compatibility with two types of nonlinguistic inferences for subgrouping

Finally, it is important to show that Approach A agrees with two types of nonlinguistic inferences for subgrouping, while Approaches B and C do not.

The notion that linguistics, archeology, and anthropology can be used cooperatively to recover linguistic genetic relations and migration history is not new. Where findings differ, there is a tendency to rely on a hierarchy of reliability in the sciences. In what follows, I discuss the compatibility of the three approaches with the archeological record (6.6.3.1) and the socio-cultural features of the Formosan aborigines (6.6.3.2).

6.6.3.1 *The Austronesian homeland: Inferences from the archeological record*

Under Hypotheses B and C, the earliest reconstructable homeland of Austronesian was located in the mountainous southern highlands of Taiwan, since three of the four primary branches in his subgrouping are distributed across this area (Ross 2012:1320). This hypothesis is extensively supported by Zeitoun & Teng's revised proposal (see Section 6.3.2.2), as the additional layers occupied by Saaroa and Kanakanavu within the fourth primary branch indicate the southern highlands as the region with greatest linguistic diversity. On the other hand, as has been discussed in Section 6.2, the phonological evidence from higher-level AN languages points to a rake-like distribution of the Austronesian people's early settlements, as the nine primary branches present a diverse distribution across the island without an obvious center of dispersal.

Which hypothesis is more plausible under the broad picture? The archeological evidence favors the latter. The mainstream view in archaeology suggests that the Austronesian settlement in Taiwan was a Neolithic dispersal from mainland southeast China around 5,000 years ago (C.-H. Tsang, personal communication). Specifically, K.-C. Chang (1989:95) has noted that: "if there were major radiations of Proto-Austronesians from the Southeast China homeland (including Taiwan), they probably began no later than the period of the Tapenkeng (TPK) culture." If this proposal is on the right track, Tsang's (2005:69) report of the TPK culture implies a diverse distribution of early AN people's settlements on both sides of the island and mostly in the coastal areas (M.-C. Yeh 2010):

In recent years, more and more TPK culture sites have been gradually recovered around the southern, north and eastern coasts of Taiwan. In the South, three sites including Fute-yie-miao, Liu-he and Kung-chai were discovered on the Fengshan tableland in Kaohsiung County (Tsang et al. 1994), and Nan-kuan-li and Nan-kuan-li East were found on the flood plain in Hsinshih Hsiang of Tainan County (Nanke Archeological team 2002). In the North, remains of the TPK culture were found in the site of Yuan-shan, Chih-san-yian, and Kuan-tu of the Taipei Basin (Liu et al. 1996; Liu 2002), as well as in a series of sites including Chuang-tsoo, Pei-tao-chiao, Teng-kung Kuo-hsiao, Si-chan-chiao and Kuo-hsi-tzu, etc. on the terraces along the northern coast (Liu 2002). TPK style potsherds have also been found in several sites on the east coast of Taiwan, [.....].

Although there is no direct evidence for the TPK culture sites being occupied by Austronesian speakers, there is no plausible alternative to this assumption. Importantly, there has been no archeological evidence that any interior part of the island was the primary center of dispersal, especially the southern highlands. The Austronesian settlement of the Pacific islands also shows a strong preference for primary settlement on the coasts. An archeological study of the environmental settings of 28 Lapita sites shows that all sites—even the few rock shelters and those that are some distance inland today—were originally on the coast at the time they were inhabited. And all sites were situated facing passages in the reef through which canoes could come and go, as the marine environment and its resources are crucial for the communities (Lepofsky 1988). A center

of dispersal situated in the highlands of southern Taiwan is not only incompatible with the archeological evidence, but also fails to agree with what is known about the Austronesian settlements throughout the Pacific islands, and elsewhere in the Austronesian world.

In sum, the phonological evidence implies an early settlement pattern that agrees with the archeological record, whereas the two proposals based on proposed morpho-syntactic innovations conflict with it. This, together with issues in Approaches B and C discussed previously, suggests that Approach A constitutes a more reliable means of subgrouping.

6.6.3.2 Sociocultural classification of Formosan aborigines

Finally, the phonological evidence for subgrouping is in accord with Ferrell's (1969) classification of major cultures of the Formosan aborigines. As seen in a comparison between (41) and the subgrouping reached by Approach A (40), both recognize Bunun, Atayalic, Tsouic, Western Plains, and East Formosan as independent groups. On the other hand, the two apparent morphosyntactic innovations fail to identify any of the culture groups acknowledged by Ferrell (1969:30–58):

(40) TABLE 6.13. Main cultures of Formosan aborigines (Ferrell 1969)

	Material culture	Religion and oral tradition	Language
Atayal culture	<ul style="list-style-type: none"> • No pottery, decorative stone, woodcarving, and painting • Semi-subterranean house • No men's houses or public buildings 	<ul style="list-style-type: none"> • No mention of the sea • Ancestors emerged from a giant stone or a mountain • Absence of cosmogony or deities • <i>Utux</i> signifies all kinds of supernatural spirits 	Atayal, Seediq
Tsou culture	<ul style="list-style-type: none"> • No stone-carving and decorative wood • Manufactured pottery; leather used for clothing; bark container • Unique Tsouic style house • Men's meeting house 	<ul style="list-style-type: none"> • Particularized named gods and spirits (contra. Atayal and Bunun Cultures) • Originated in Yushan, and later split into Northern Tsou and Southern Tsou. Southern Tsou moved down along Laonung River and further split into two (Li 2001a:273) 	Tsou, Saaroa, Kanakanavu
Bunun culture	<ul style="list-style-type: none"> • No woodcarving or painting • Manufactured pottery • House-style distinct from Atayal or Tsouic 	<ul style="list-style-type: none"> • Little cosmogony; no mention of the sea • Periodic offering to the moon • Rich animal and hunting stories 	Bunun
Paiwan culture	<ul style="list-style-type: none"> • Wood and stone carving with stylized human head, snake, and deer • Bronze heirloom • House style similar to Bunun 	<ul style="list-style-type: none"> • Little cosmogony • The belief that the chiefly families are descended from the sun • Ramage-type social structure 	Paiwan, Rukai

Lowland culture	<ul style="list-style-type: none"> • Rectangular, ground-level houses of bamboo/thatch • Bark cloth garment 	<ul style="list-style-type: none"> • ‘Story of the White Deer’ (Blust 1996:281-2) suggesting Thao was originally located in the Western Plains 	Western-Plain languages
Littoral culture	<ul style="list-style-type: none"> • Elevated bamboo and thatch houses on piles • Boats and canoes mentioned in early sources 	<ul style="list-style-type: none"> • Traditions of oversea origin: “Sanasay” • Matrilineal culture • Highly developed cosmogonic myths and vast pantheons, including powerful spirits of the sea 	East Formosan languages, Puyuma

(41) FIGURE 6.19. Approach A: The phonology-based subgrouping

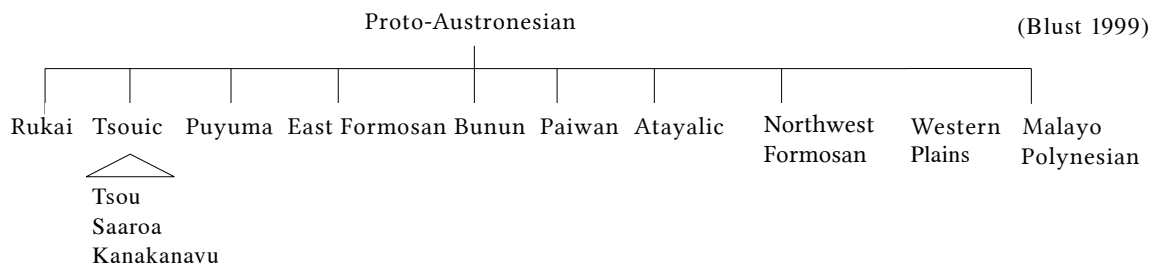

Along with its compatibility with lexical and archeological evidence, the phonology-based subgrouping is thus additionally supported by inferences from the sociocultural classifications in (40).

6.7 Conclusion and implications

In this chapter, I have evaluated recent approaches to the primary-level subgrouping of Austronesian, and demonstrated that exclusively shared phonological innovations provide a more reliable means for subgrouping.

I first showed that a subgrouping based on exclusively shared phonological innovations yields consistent results with inferences from (a) lexical innovations, (b) the archeological record, and (c) the sociocultural classifications of Formosan aborigines. I then argued that the two types of morphosyntactic variations discussed in this chapter (i.e., the presence or absence of N-V homophony and that of Philippine-type voice distinction in root clauses) are not a reliable means for subgrouping, as their directionality of change is less predictable than that of phonological innovations. Following this claim, I demonstrated that subgroupings based on the purported innovations of (i) ‘Nominalization-into-verb’ and of (ii) the emergence of ergativity are in conflict with (a)–(c), and therefore do not constitute reliable subgrouping criteria.

Finally, I pointed out that the diachronic analyses (i)–(ii) are founded on synchronic analyses that have been shown untenable in Chapters 2–5. Following this conclusion, I revisit the historical derivation of the variation in (i) and (ii) in Chapters 7.

Chapter 7

The nature of Austronesian “nominalizer-voice affix homophony” and its synchronic variation

In this chapter, I revisit the nature of Austronesian *nominalizer-voice affix (N-V) homophony*, and investigate the following two questions:

- (i) What is the best account for its absence in Rukai, Tsou, and Puyuma?
- (ii) Is the lack of Philippine-type voice distinctions in Rukai’s root clauses retentive or innovative?

I argue that the apparent phenomenon of “N-V homophony” essentially reflects Philippine-type voice morphology present in different syntactic environments: while those in root clauses are termed *voice affixes*, those in finite relative clauses are conventionally called *nominalizers*, despite their being voice affixes in nature. I argue accordingly that the alleged derivational relation between “nominalizer” and “voice affix” is unmotivated. Following this claim, I show that the lack of “N-V homophony” in Rukai, Tsou, and Puyuma is best analyzed as reflecting independent morphological reductions, where root-clause morphology has undergone extensive loss, with conservative morphology preserved under subordination. Under this analysis, the lack of voice distinctions in Rukai’s root clauses is an instance of extensive loss. I conclude therefore that the presence of N-V homophony does not constitute evidence for subgrouping, as it reflects a *retention*, rather than a *shared innovation*. The conflict between the Nuclear Austronesian Hypothesis (Approach B) and other types of subgrouping evidence can thus be resolved. This analysis shares a conclusion with Chapter 5, that “N-V homophony” is a prototypical feature of the Philippine-type voice system. I show that this analysis requires the smallest number of innovations to derive the synchronic facts.

7.1 Introduction

The nature and historical derivation of Austronesian *nominalizer-voice affix (N-V) homophony* (1a)-(b) has been a central interest in recent work. As discussed in Chapter 6, the Nuclear Austronesian hypothesis (Ross 2009, 2012) has argued that this homophony arose from a post-Proto-Austronesian innovation that excluded primary-level offshoots, as in (2).

(1) *Nominalizer-voice affix homophony in Paiwan*

- a. **kan-en** ni kama a vasa. [Patient voice affix: *-en*]
eat-PV GEN(X)¹ father PIVOT taro
 ‘Father ate the taro.’
- b. talagalj aken tua tja **kan-en.** [Patient nominalizer *-en*]
 cook<AV> 1SG.PIVOT ACC 1PL.EXL.POSS **eat-“PV.NMZ”**
 ‘I cooked our {thing to be eaten/food}.’ (ODFL)

(2) *FIGURE 7.1. The Nuclear Austronesian hypothesis*

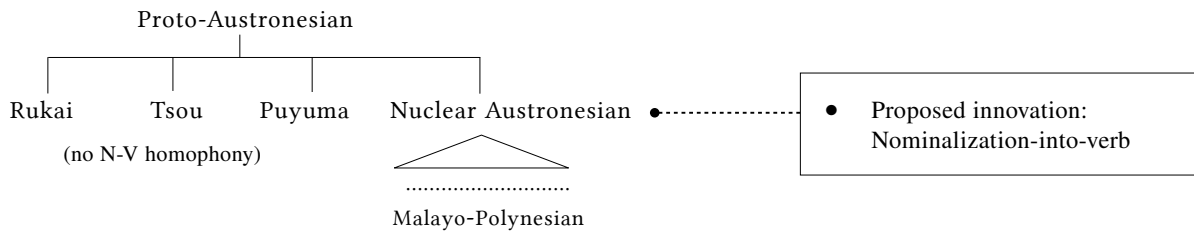

In this chapter, I present an alternative view to this proposal along two lines. I first show that the hypothesis of *Nominalization-into-verb* (Starosta, Pawley, & Reid 1982) is not a valid diachronic proposal for the origin of Austronesian N-V homophony. I then demonstrate that the subgrouping in (2) assumes a directionality that makes it difficult to account for the synchronic facts. Following these two claims, I argue for the analysis in (3).

(3) *Main claims of the chapter*

- N-V homophony is the prototypical pattern of the Philippine-type voice system. Its absence reflects pattern reductions in innovative languages. Therefore, the presence of the feature does not constitute evidence for subgrouping.
- The conventional term “*nominalizer*” essentially refers to Philippine-type voice affixes present in finite relative clauses. Assuming “*nominalizers*” to be the diachronic source of indicative voice affixes is unmotivated, as “*nominalizers*” are voice affixes in nature.
- It has been overlooked that voice affixes in relative clauses (i.e., “*nominalizers*”) inflect for non-indicative moods just as root-clause morphology does. This observation undermines the empirical starting point of the Nuclear Austronesian hypothesis, that *Philippine-type indicative voice affixes have a special connection with “nominalizers” while non-indicative affixes do not*. It also reinforces the claim that “*nominalizers*” are voice affixes in nature.

¹ To facilitate understanding for historical linguists, I use the conventional label ‘Genitive’ instead of ‘X’ to gloss the argument marker on the external argument of non-AV clauses, which was used in Chapters 2–5.

- d. Many Austronesian languages have undergone morphological simplifications in the direction of *root clause prior to subordinate clause*. The lack in of “N-V” homophony in root clauses reflects pattern reductions in root clauses that have not occurred to relative clauses.
- e. Rukai is one of the languages that have undergone this extensive loss. Its lack of voice distinctions in root clause reflects an innovation, rather than a retention.

This chapter is organized as follows. I begin with a brief methodological review of morphosyntactic reconstruction in Section 7.2. In Section 7.3, I critique the Nominalization-into-verb hypothesis and provide a novel account for Austronesian N-V homophony. Along the lines of this analysis, I present a pattern reduction account for the absence of N-V homophony in Section 7.4, and provide novel evidence to justify the proposed directionality. In Section 7.5, I revisit the synchronic variation in N-V homophony from the current position, and discuss parallel observations in extra-Formosan languages. Section 7.6 summarizes and concludes.

7.2 Three common issues in morphosyntactic reconstruction

It has been commonly acknowledged that several fundamental problems exist in applying the techniques of phonological reconstruction to morphosyntax. This is because morphosyntactic innovations do not always follow general tendencies of directionality in the same ways that sound changes usually do (see, e.g., Jeffers 1976; Lightfoot 2002; Barðdal & Eythórsson 2012; Walkden 2013). In this section, I discuss three issues relevant to this chapter.

7.2.1 The directionality problem

In phonological reconstruction, generalization about the predictable direction of sound change enables a confident determination of proto-sounds. For instance, $x > k$ and $tʃ > k$ are highly unlikely changes, whereas $k > x$ and $k > tʃ$ are crosslinguistically common. Determining the proto-form *k among the synchronic variants /k/, /tʃ/, and /x/ is thus uncontroversial (4a).

(4) *The directionality problem in morphological and syntactic reconstructions*

<i>a. phonological variants</i>	<i>b. morphological variants</i>	<i>c. syntactic variants</i>
Language A /k/	Language A ta- (causative)	Language A SOV
Language B /tʃ/	Language B b- (causative)	Language B SVO
Language C /k/	Language C ta- (causative)	Language C SOV
Language D /x/	Language D lina (causative)	Language D SVO
Proto-ABCD *k	Proto-ABCD ?	Proto-ABCD ?

Morphological and syntactic reconstructions, however, are less straightforward, as the evolution of morphology and syntax has been found less predictable. Determining the proto-form of synchronic morphosyntactic variation is thus often controversial, and requires intricate deductions—especially since morphological changes often involved lexical replacement of a function. (4b) illustrates a typical example. Let us assume that Languages A-D are genetically related, and that only A and C employ a causative prefix that appears to be cognate. Whether *ta-* can be reconstructed to Proto-ABCD requires careful argumentation, as the chronology of *ta-* and the two seemingly unrelated morphemes cannot be determined until the subgrouping relation of A, B, C, and D is made clear: If Proto-ABCD comprises two subgroups, A-B and C-D, it is plausible to assume *ta-* in A and C to be a direct inheritance from Proto-ABCD, with *b-* and *lina* being innovations (lexical replacements). If, however, Proto-ABCD comprises two subgroups, A-C and B-D, *ta-* cannot be traced back to Proto-ABCD without other evidence, as it can be a secondary innovation at Proto-AC. In brief, the directionality of morphological change is often not self-evident as that of phonological innovations is.

Another classic example is the reconstruction of word order (4c). As word order change does not follow a universal directionality, determining the prototype often remains controversial due to a lack of standard methodology.

Subgrouping proposals founded on a purported directionality of morphosyntactic changes should thus be treated with caution.

7.2.2 The pitfalls of negative evidence

There is a type of directionality problem that deserves a separate discussion, namely, cases where one (or more) of the comparisons is a zero, as in (5):

(5)	Language A	\emptyset
	Language B	<i>X</i>
	Language C	<i>X</i>
	Language D	<i>X'</i>

In principle, the synchronic absence of the feature *X* in Language A allows two diachronic interpretations: (a) *X* never existed, indicating that the absence is a *retention* (Scenario I), and (b) *X* was lost, indicating that the absence is an *innovation* (Scenario II). Both scenarios are a priori possible:

(6) *The pitfalls of negative evidence: why (a), not (b)?*

a. *Scenario I (X never existed)*

Proto-ABCD	* \emptyset
Language A	\emptyset (retention)
Language B	X
Language C	X
Language D	X'

- ☞ X could be a shared innovation
- ☞ X can be used for subgrouping

b. *Scenario II (X was lost)*

Proto-ABCD	*X
Language A	\emptyset (innovation)
Language B	X
Language C	X
Language D	X'

- ☞ X is a retention
- ☞ X cannot be used for subgrouping

Under Scenario I (6a), Language A retains the absence of X from Proto-ABCD. The presence of X in Languages B—D is thus a potential shared innovation that constitutes evidence for subgrouping.² Under Scenario II (6b), however, the absence of X reflects an independent loss. The presence of the feature in Languages B-D thus does not constitute evidence for subgrouping, as X is not a shared innovation that excluded Language A.

As both scenarios can derive the synchronic facts in (5), assuming one over the other without evidence is methodologically flawed. Proposals that do not consider a “loss” scenario (6b) thus risk making diachronic inferences based on negative evidence. I will revisit this issue in 7.4.

7.2.3 Issues in proposing replacement reanalysis in primary-level reconstruction

Finally, a specific issue in primary-level reconstruction deserves a note. Proposals of morphosyntactic reanalysis can be divided into two types: (i) reanalyses claimed to derive a previously non-existing grammatical item (e.g., the grammaticalization of a lexical verb into a functional verb, bound affix, or clitic), and (ii) reanalyses claimed to *replace* a previously existing morpheme and the function it carried. Proposing replacement-type reanalyses in primary-level reconstruction is disfavored, as it leaves the proto-form unreconstructable.

The Nominalization-into-verb hypothesis can be used to illustrate this problem. As discussed in Chapter 6, this analysis holds that the synchronic indicative voice affixes were derived from archaic nominalizers through a purported morphosyntactic reanalysis, as in (7). As it is implausible to assume a proto-system with no indicative clauses prior to this reanalysis, Nominalization-into-verb implies an entire elimination of the archaic verbal affixes by the

² Note that the presence of X in Languages B-D could also be a chance convergence, borrowing, or a product of parallel *drifts* (i.e., parallel changes).

innovative voice affixes.³ This proposed morphological replacement leaves a crucial question unanswered: what were the Proto-Austronesian verbal affixes prior to the reanalysis? Despite its obvious importance, there is little way to answer the question.

(7) *A vacancy issue in the replacement reanalysis under the Nom-into-verb hypothesis*

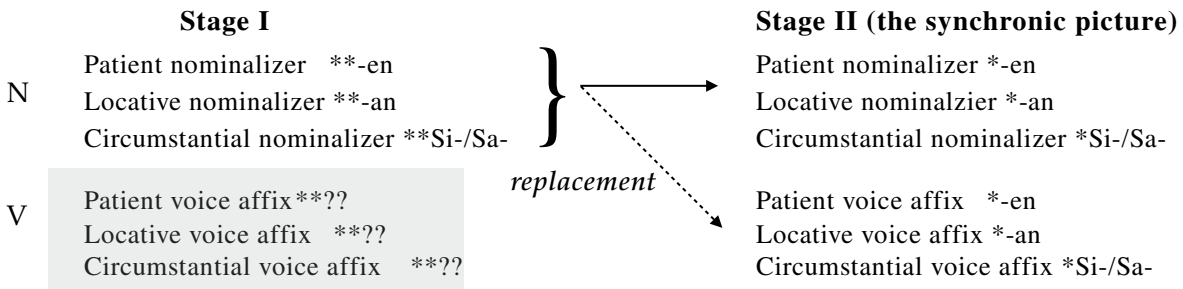

More details of this proposed replacement reanalysis are discussed in 7.3–4.

7.2.4 What constitutes a reliable morphosyntactic reconstruction?

To avoid the issues discussed above, I outline the following principles adopted in this chapter.

- 1 **Synchronic evidence for the proposed directionality.** As the directionality of morphosyntactic changes is often difficult to predict, a sound morphosyntactic reconstruction must be accompanied by concrete evidence justifying the proposed direction of change, and against the alternatives.
- 2 **Accountability for understudied constructions and phenomena.** A reliable reconstruction should not only account for the best-known phenomena or observations in simple clauses, but also for the synchronic morphosyntax as a whole. Thus, a good way to evaluate a proposal is to investigate its accountability for specific syntactic environments where two competing analyses make different predictions.
- 3 **The Economy Principle (Ockham’s Razor).** An optimal reconstruction requires the smallest number of innovations to derive the synchronic facts.
- 4 **Avoidance of replacement proposal at treetop.** With the availability of other alternatives, proposing replacement-type reanalysis in primary-level reconstruction should be avoided.

³ As a nominalism approach to Philippine-type languages (Kaufman 2009) has been critiqued by a number of recent works (see, e.g., Coon 2009; Gil 2009; Himmelmann 2009; Richards 2009; Hsieh 2016), I do not consider it a plausible account here. Further, under the Nuclear Austronesian hypothesis, it is disfavored to assume a Proto-Austronesian system with no voice distinction, given that two of its primary branches, Tsou and Puyuma, each exhibit a four-way system. Therefore, if a four-way system is not reconstructed, the system in Tsou and Puyuma needs to be explained as a product of drift, which is highly unlikely.

With these principles in mind, I revisit the Nuclear Austronesian hypothesis.

7.3 Austronesian N-V homophony: An alternative account and why *Nominalization-into-verb* is not a sound proposal

As discussed in Chapter 6, the Nominalization-into-verb hypothesis is founded on three core assumptions (8a)-(c). In this section, I begin with a reconsideration of the first assumption (8a).

- (8) a. Austronesian N-V homophony arose from an archaic innovation of *Nominalization-into-verb*, which reanalyzed nominalizers into indicative voice affixes.
- b. This reanalysis took place after Rukai, Tsou, and Puyuma split off from Proto-Austronesian, resulting in their lack of N-V homophony.
- c. This reanalysis took place in a step-by-step manner. Saaroa and Kanakanavu split off at different stages of this development, and so exhibit N-V homophony only in some of the primary affixes.

By revisiting the synchronic facts behind the Nominalization-into-verb hypothesis, I present an alternative account for Austronesian N-V homophony, summarized as follows:

Prototypical Philippine-type voice morphology inflects for three moods. The Nominalization-into-verb (Nom-into-V) hypothesis was a misinterpretation of the fact that relative clauses are seldom formed in non-indicative moods, and thus rarely contain non-indicative voice morphology. Since the voice affixes in relative clauses are conventionally called *nominalizers*, previously works have incorrectly assumed a diachronic relation between Philippine-type indicative voice affixes and “nominalizers”.

In this section, I demonstrate that there is essentially no empirical motivation to assume a derivational relation between the affixal morphology in relative clauses and the indicative voice affixes in root clauses. Under the present analysis, Austronesian N-V homophony is an apparent phenomenon created by the naming convention that distinguishes Philippine-type voice affixes in different syntactic environments.

7.3.1 The Nominalization-into-verb hypothesis: Overview

7.3.1.1 The synchronic facts

The Nom-into-V hypothesis is motivated by three common traits of Philippine-type languages: (i) *Mood distinctions in Philippine-type voice morphology*, (ii) *nominalizer-voice affix homophony*, and (iii) *possessor-genitive homophony*, summarized below:

- c. sa-salem-an
 Ca.red-grow-LV."NMZ"
 'place to be grown with X'
- c'. tu=uma' kan atrung na(n) [_{RC} ku=sa-salem-an].
 3.poss=field LK Atrung PIVOT [_{RC} 1SG.POSS=CA.RED-grow-LV."NMZ"]
 'Atrung's field is the place I will grow (something).'

As discussed in Chapter 5, these three types of constructions in fact share the same structure: a fully finite relative clause. Therefore, the conventional term *nominalizer* essentially refers to Philippine-type voice affixes present in relative clauses.¹⁰ The phenomena of “N-V” homophony is illustrated in (13), which shows that the primary affixes used in root clauses share the same form with those used in relative clauses (i.e., the “nominalizers”).

(13) *Nominalizer-voice affix homophony in Seediq*

- a. b-bariq-un na pawan kusun ka patis nii. [patient voice affix *-un*]
 RED-buy-PV GEN(X) Pawan tomorrow PIVOT book this
 'Pawan will buy this book tomorrow.'
- b. patis nii ka [_{RC} b-bariq-un na pawan]. [patient “nominalizer” *-un*]
 book this PIVOT [_{RC} RED-buy-PV."NMZ" GEN(X) Pawan]
 'This book is {what Pawan will buy}.'

If “nominalizers” are voice affixes present in finite relative clauses, we expect to observe “N-V” homophony with all the four Philippine-type voice affixes, not just with the three non-AV affixes assumed by the Nom-into-V hypothesis. This prediction is borne out with observations from at least nine Philippine-type languages. As seen below, across Puyuma, Seediq, and Kavalan, an AV affix may appear in both root clauses and pseudo-clefts, just as the three non-AV affixes do.¹¹

(14) *Bi-functional Actor voice affix in Puyuma*

- a. imanay na [_{RC} m-ekan kanu=bunga]?
 who PIVOT [_{RC} AV-eat 2SG.ACC(Y).POSS=yam]
 'Who is the one that ate your yam?'
- b. m-ekan i isaw kanu=bunga.
 AV-eat SG.PIVOT Isaw 2SG.ACC(Y).POSS=yam
 'Isaw ate your yam.'

¹⁰ As discussed in Chapter 5, the presupposed clauses of pseudo-clefts is standardly analyzed as a headless relative clause (see, e.g. Potsdam 2006, 2009; Aldridge 2004; Pearson 2009; D. Lin 2013). Also see Chapter 5 for an analysis in which the nominals in (11c) and (12c) exhibit the structure of a headless relative clause.

¹¹ Based on available data, languages that show N-V homophony with the AV affix include Puyuma, Atayal, Seediq, Pazeh, Paiwan, Kavalan, Bunun, Tsou, Tagalog, and Subanon. To the best of my knowledge, the same observation applies to other Philippine-type languages.

(15) *Bi-functional Actor voice affix in Seediq*

- a. ima ka [RC **m**<n>ekan Ø sari=su]?
who PIVOT [RC **AV**<PRF>eat ACC(Y) taro=2SG.POSS]
'Who is the one that ate your taro?'
- b. **m**<n>ekan Ø sari=mu ka temi.
AV<PRF>eat ACC(Y) taro=1SG.POSS PIVOT Temi
'Temi ate my taro.'

(16) *Bi-functional Actor voice affix in Kavalan*¹²

- a. ti tiana ya [RC s<**m**>ipit tu sunis]?
PN who PIVOT [RC <**AV**>pinch ACC child]
'Who is the one that pinched the child?'
- b. s<**m**>ipit tu sunis ya baqi.
<**AV**>pinch ACC(Y) child PIVOT old.man
'The old man pinched the child.'

To conclude, N-V homophony is manifested in all the four Philippine-type voice affixes. Thus, there is no sound evidence to assume a distributional asymmetry between the AV and non-AV affixes.

III. Possessor-Genitive (X) homophony

The phenomenon of possessor-genitive homophony is illustrated in (17), which shows that non-Pivot-marked agents in non-Actor voice clauses (17a) share the same marking with possessors (17b)-(c):

(17) *Nominalizer-voice affix homophony in Seediq*

- a. wada biq-un **na** iwan ka patis. [non-Pivot agent marker *na*]
PRF buy-PV **GEN(X)** Iwan PIVOT book
'Iwan bought the book.'
- b. huling **na** iwan [possessor marker *na*]
dog **POSS** Iwan
'Iwan's dog'

To connect the current discussion to the preceding chapters, I illustrate this phenomenon with the abstract labels used in Chapters 2–5. As seen in (18), in Philippine-type languages, the X-marking (labeled as Genitive in this chapter) present on the external argument of PV, LV, and CV clauses is homophonous with the possessive marker. While the exact form of X varies, this homophony is consistently observed across languages. To facilitate understanding for historical

¹² I thank Dong-yi Lin for the Kavalan data and helpful discussion. (31b) is taken from Jiang (2016:8).

linguists, I use the terms ‘agent’ and ‘patient’ instead of ‘external argument’ and ‘internal argument’, which were used in Chapters 2–5.

(18) TABLE 7.2. *Argument-marking pattern in the Philippine-type voice system*

	AV	PV	LV	CV	
Agent	Pivot	X	X	X	= Possessor marking: X (“GEN”)
Patient	Y	Pivot	Y	(Y)	
Location	LOC	LOC	Pivot	(LOC)	
Inst./Ben.	(Y)	(Y)	(Y)	Pivot	

7.3.1.2 The Nominalization-into-verb hypothesis revisited

In what follows, I discuss how the Nominalization-into-verb hypothesis (8a) approaches the synchronic facts discussed above.

Starosta, Pawley, & Reid (1982) have argued that Austronesian “N-V” homophony arose from an archaic innovation that reanalyzed pseudo-cleft constructions (19a) into synchronic non-AV indicative clauses (19b). This reanalysis is claimed to account for two synchronic facts: 1) the homophony of patient, locative, and circumstantial nominalizers with patient, locative, and circumstantial voice affixes, and 2) possessor-genitive (X) homophony in non-AV clauses.

(19) *The proposed reanalysis of Nom-into-V*¹³

a. *Stage I: before Nom-into-V*

[ka	qaLup- en	ni	aLak]	ka	babuy	[patient “nominalzier” -en]
[DET	hunt-“ PV .”	“ NMZ ”	GEN(X)	child]	PIVOT	boar
‘What the child hunted was the boar.’						

b. *Stage II: after Nom-into-V*

qaLup- en	ni	aLak	ka	babuy.	[patient voice affix -en]
hunt- PV	GEN(X)	child	PIVOT	boar	
‘The child hunts the boar.’					

The proposed derivation of this reanalysis is illustrated in (20). It is argued that the Grade I (indicative) affixes were derived from their corresponding “nominalizers”, while the Grade II and Grade III (non-indicative) affixes were verbal since the beginning. This purported reanalysis is claimed to be restricted to non-AV affixes (PV *-en, LV *-an, and CV *Si-/Sa-), as seen in (21). A discussion of why the AV affix is excluded will be presented in 7.3.3.2.

¹³ This example is taken from Ross (2014), which is similar to the pseudo-cleft data used in Starosta, Pawley, & Reid (1982).

(20) TABLE 7.3. *The Nominalization-into-verb hypothesis*

	AV	PV	LV	CV	
	—	*-en	*-an	*Si-/Sa-	“nominalizer”
a. Grade I	*<um>	*-en	*-an	*Si-/Sa-	indicative
b. Grade II	*-a	*-aw	*-ay	*-anay	optative, hortative
c. Grade III	*-∅	*-u	*-i	*-an	imperative, negative

← “Nom-into-V”

(21) *Proposed functional expansion of the primary affixes under the Nom-into-V hypothesis*

- a. *Patient nominalizer → Patient nominalizer/voice affix
- b. *Locative nominalizer → Locative nominalizer/voice affix
- c. *Circumstantial nominalizer → Circumstantial nominalizer/voice affix
- d. *perfective affix for nominals → perfective marker for nominals/verbs
- e. *possessor → possessor/the agent in non-AV clauses
- f. *possessor marker → possessor marker/marker for agent in non-AV clauses

In sum, the Nom-into-V hypothesis is founded on three assumptions. First, the Philippine-type voice morphology presented in pseudo-clefts differs from that in root clauses in nature. Second, synchronically, only the Grade I and not the Grades II/III affixes can appear in pseudo-clefts and be used as a “nominalizer”, hence, there is a special connection between “nominalizers” and synchronic Grade I (indicative) voice affixes. Third, only non-AV affixes participated in the reanalysis of Nom-into-V.

Following these assumptions, Aldridge (2014, 2016) has articulated the Nominalization-into-verb hypothesis under the Minimalist framework, according to which Nom-into-V was a relabeling process in which a nominal predicate (22a) changed to a verbal construction (22b) through the relabeling of *n* to *v*.

(22) *Austronesian noun/verb homophony under the Nom-into-V hypothesis*

a. *before the reanalysis*

b. *after the reanalysis*

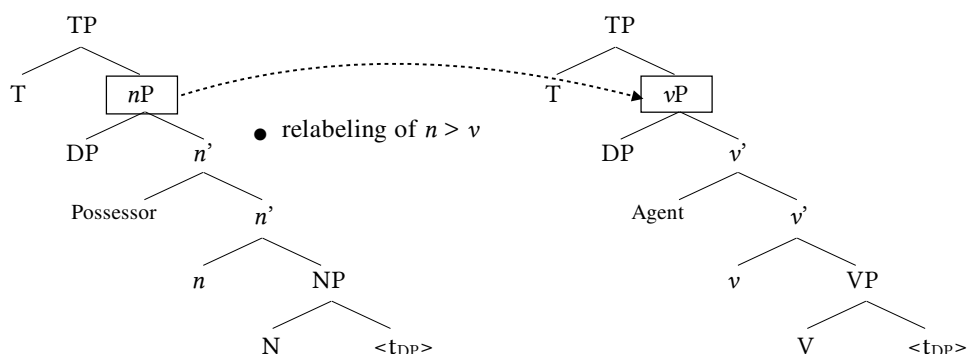

Under the analysis in (22), recent work (Kaufman 2009, 2017; Aldridge 2014) has further attributed the Philippine-type Pivot-only constraint in A'-extraction to a *by-product* of Nom-into-V, according to which the inability of non-Pivot agents to undergo A'-extraction is due to their origin as a possessor—which is inherently licensed by a preposition. Under this analysis, the Philippine-type extraction asymmetry arose from a ban on extracting inherently Case-licensed agents in non-AV clauses, as in (23):¹⁴

(23) *Recent development of the Nom-into-V hypothesis (Kaufman 2017)*

a. <i>n</i> properties:	b. synchronic <i>v</i> properties:
possessor is projected [Spec, <i>n</i>] genitive case to <i>nP</i> -internal phrases strong island properties	agent is projected in [Spec, <i>v</i>] accusative case to object islandhood dependent on <i>v</i> features

7.3.2 Austronesian N-V homophony: An alternative account

In this section, I present an alternative account for Austronesian N-V homophony, and point out how several synchronic facts have motivated the misanalysis of Nom-into-V.

Along the lines of the conclusion of Chapter 5, I argue that the Philippine-type voice morphology present in pseudo-clefts shares the same syntactic property with that in root clauses. Therefore, what were considered as “nominalizers” are in fact ordinary voice affixes used in relative clauses embedded under a nominal, as illustrated in (24a)-(b).¹⁵ As there is no sound reason to assume a derivational relation between the same grammatical item used in different environments, the Nominalization-into-verb hypothesis is unmotivated.¹⁶

This analysis is founded on the observation that the presupposed clauses of pseudo-clefts are finite full clauses in these languages. As a finite CP analysis for this construction has been

¹⁴ Note that this analysis assumes an applicative analysis for LV and CV clauses, which enables the proposal that the structurally highest internal argument in non-AV clauses is accessible to A'-extraction due to the immobile agent that is inherently Case-licensed. This analysis therefore relies critically on the assumption that the AV affix is excluded from the reanalysis of Nominalization-into-verb.

¹⁵ Namely, what was considered as “nominalized environment” is in fact CP-level nominalization similar to relative clauses in English, e.g., the car_i [_{CP} that I thought Bill will like ____i]. See Chapter 5 for a detailed analysis.

¹⁶ This claim precludes the probability that Proto-Austronesian had only relative clauses. See 7.3.4 for an argument against an insubordination (de-subordination) analysis for Austronesian N-V homophony.

presented in Chapter 5, which agrees with the standard analyses (see, e.g., Potsdam 2006, 2009; Aldridge 2004), I do not repeat it here.¹⁷

(24) *Proposal: “nominalizers” are voice affixes in finite RCs embedded under a nominal*

- a. “voice affix”: [CP TopP_[u6] ... C [TP V ... DP₁ DP_{2[6]} ...]]
↑-----↑
“voice affix”
- b. “nominalizer”: [DP D [CP TopP_[u6] ... C [TP V ... DP₁ DP_{2[6]} ...]]
↑-----↑
“voice affix”, conventionally called *nominalizer*

An important piece of evidence for the current analysis lies in the availability of mood inflections inside relative clauses: If what were conventionally called “nominalizers” are indeed voice affixes, they should inflect for three moods just as voice affixes in root clauses do.

This prediction is borne out with the data below. Examples (25)-(26) show that Grade II morphology is available in both root clauses and pseudo-clefts in Seediq and Siraya, two languages under different Austronesian primary branches.

(25) *Grade II CV affixes in both root clauses and clefts (“nominalization”): Seediq¹⁸*

- a. keret-**ani**=su Ø sagas ka yayu [root clause]
cut-CV.GRADE2 ACC(Y) watermelon PIVOT knife
‘You should cut the watermelon with knife.’ (primary data)
- b. yayu niyi ka [(RC) keret-**ani** Ø sagas] [pseudo cleft]
knife this PIVOT [(RC) cut-CV.GRADE2 ACC(Y) watermelon]
‘This knife is what one should cut the watermelon with.’ (Tsukida 2009:236,447)

¹⁷ As discussed in Chapter 5, there is no evidence for a deficient analysis for relative clauses/the presupposed clause of pseudo-clefts, as both show no restriction in hosting aspect markers, voice affixes, and case marking. The structure of pseudo-cleft is thus analyzed as follows: [PREDICATE] PIVOT [DP D [CP C ... [V...]]. It is similar to pseudo-cleft in English in the sense that the presupposed clause is a finite CP. For instance,

- a. Who was [DP the man_i [CP that ____i kissed Mary]]? (relativization of agent)
b. What was [DP the thing_i [CP that Mary gave ____i to you]]? (relativization of patient)
c. What was [DP the place_i [CP that Mary brought you to ____i]]? (relativization of location)
d. What was [DP the thing_i [CP that Mary cut the pork with ____i]]? (relativization of instrument)

¹⁸ The availability of the so-called ‘1st-generation affixes’ in nominalized environments was first pointed out in Jiang (2016). His observation was later confirmed with my Seediq informant. This observation constitutes strong supporting evidence for my analysis.

(26) *Grade II PV affixes in both root clauses and clefts (“nominalization”): Siraya¹⁹*

- a. pi-i-alak-**aw** lava tumang ta ti jesus?
 K-LOC-offspring-PV.GRADE2 perhaps where PIVOT PN Jesus
 ‘Where will this Jesus be born?’
- b. mang ta [(RC)kan-**aw**=mian]? mang ta [(RC)it-**aw**=mian]?
 what PIVOT [(RC)eat-PV.GRADE2=1PL.EXL.GEN(X)] what PIVOT[(RC)drink-PV.GRADE2=1PL.EXL.GEN(X)]
 ‘What are we going to eat? What are we going to drink?’ (Adelaar 2011:96,91)

The availability of Grade II affixes in the pseudo-clefts (“nominalized environment”) in (25b) and (26b) follows directly from the present analysis, as finite subordinate clauses are expected to be free for mood inflections. This observation, however, presents a serious issue for the Nominalization-into-verb hypothesis, according to which Grade II affixes originate as “verbal affixes”, and can never appear in pseudo-clefts and function as a “nominalizer”.

As expected from the current analysis, Grade III affixes are available in relative clauses/ pseudo-clefts as well. Although an imperative mood is presumably impossible in relative clauses, Grade III affixes are available in relative clauses that contain negation, as seen in the data below from Puyuma and Seediq (27)-(28):

(27) *Grade III LV affixes in both root clauses and relative clauses: Puyuma (Rikavung)*

- a. mau~mau i misak na [(RC) ‘azi ku=tengez-**i**]
 EMPH~COP SG.PIVOT Misak PIVOT [(RC) NEG 1SG.GEN(X)=beat-LV.GRADE3]
 ‘Misak is the one that I didn’t beat.’
- b. ‘azi ku=tengez-**i** i misak.
 NEG 1SG.GEN(X)=beat-GRADE3 SG.PIVOT Misak
 ‘I did not beat Misak.’ (Jiang 2016:189,188)

(28) *Grade III LV affixes in both root clauses and relative clauses: Atayal*

- a. buqoh nanak qu [(RC) ini=nya **niq-i**]
 banana only PIVOT [(RC) NEG=3SG.GEN(X) eat-LV.GRADE3]
 ‘Banana is the only thing that he/she didn’t eat.’ (Jiang 2016:204 (T.-C. Chen p.c.))
- b. ini=nya **niq-i** qu buqoh.
 NEG=3SG.GEN(X) **eat-GRADE3** PIVOT banana
 ‘He/she didn’t eat the banana.’ (Safulao Payas p.c.)

¹⁹ Additional examples from Siraya are listed below:

I. Nominalized environment with Grade I affix:

- a. ukukua-aw [PV -aw < *-aw]
 marry-PV.IRR
 ‘someone to be married, wife-to-be’
- b. pa-i-baba’-ey [LV -ey < *-ay]
 SM-LOC-rest-LV.IRR
 ‘place where one will rest’

II. Nominalized environment with Grade II affix:

- a. pa-titil-en [PV -en < *-en]
 SM-quarrel-PV
 ‘what is quarreled about; issue’
- b. pa-i-sasu-an [LV -an < *-an]
 SM-LOC-rule-LV
 ‘place that is ruled over, kingdom.’ (Adelaar 2011:151–6)

The data above undermines the empirical starting point of the Nom-into-V analysis, which assumes that only the Grade I affixes may appear in pseudo-clefts as a “nominalizer”. Having shown that “nominalizers” in fact inflect for three moods inside relative clauses, the purported nominalization origin of Grade I affixes can thus be eliminated.

Further, this observation lends additional support to the present analysis that what were considered as “nominalizers” are in fact voice affixes in nature, as nominalizers are crosslinguistically unknown to inflect for mood.

Finally, the availability of mood inflections inside relative clauses/pseudo-clefts further strengthens the finite CP analysis of these constructions, as Mood is standardly considered as associated with finiteness.

7.3.3 Issues in the Nominalization-into-verb hypothesis

Under the present analysis, Austronesian “N-V” homophony is an illusion created by the terminological differences for Philippine-type voice affixes used in different syntactic environments. Moreover, the Nom-into-V analysis was misled by the fact that non-indicative moods are rarely used in relative clauses—which created the impression that only Grade I affixes are available inside a “nominalized environment”.

To justify this claim, I outline issues in the Nom-into-V hypothesis in this section, and discuss how they are accounted for under the present analysis.

7.3.3.1 Issue 1: The availability of non-indicative affixes within “nominalizations”

As discussed above, a major argument against the Nom-into-V analysis is the observation that non-indicative voice affixes (Grades II & III) may appear in pseudo-clefts and serve as so-called “nominalizers”. This observation falsifies the purportedly exclusive connection between the Grade I affixes and “nominalizers”. Proposing a derivational relation between the two is thus unmotivated.

7.3.3.2 Issue 2: The forgotten Actor voice and the purported AV/non-AV asymmetry

Practitioners of the Nuclear Austronesian hypothesis have excluded the AV affix from the purported reanalysis of Nom-into-V, assuming that the synchronic AV clauses are a direct retention from Proto-Austronesian, whereas the three non-Actor voice clauses were derived from the reanalysis of Nom-into-V (Ross 2009, 2012, Kaufman 2009, 2017; Aldridge 2014, 2016).²⁰ This proposal is potentially due to two observations that are inconvenient for the Nuclear Austronesian hypothesis, that AV clauses exhibit neither the possessor-genitive homophony nor a ban on A'-extracting its agent.

²⁰ Aldridge (2014, 2016) has argued that AV relative clauses in AV are not nominalized, as opposed to non-AV ones. This claim is however unsupported, as AV relatives do not show any distributional difference from non-AV relatives. Both can be placed in argument position as a headless relative clause.

Further, the AV clauses show a ban on object extraction, which is unaccounted for under the Nom-into-V hypothesis.

However, under the logic of the Nom-into-V hypothesis it is untenable to exclude the AV affix from the purported reanalysis of Nom-into-V, as its manifestation of N-V homophony needs to be explained as a chance convergence, which undermines the hypothesis itself.

7.3.3.3 Issue 3: Incompatibility of unaccusative verbs with a “Patient nominalizer”

A third issue in the Nom-into-V hypothesis lies in its inability to account for a constraint shared across Philippine-type languages, that the undergoer of unaccusative verbs is incompatible with either a Patient voice affix or the so-called “Patient nominalizer” in pseudo-clefts. This is illustrated with the data below from Seediq and Tagalog.

(29) *Incompatibility of unaccusative verb under PV*

- a. *huqil-un/√mp-huqil kusun ka riso nii. [Seediq]
 die-PV /√AV.IRR-die tomorrow PIVOT young.man this
 ‘This young man will die tomorrow.’
- b. ima ka {*huqil-un /√mp-huqil kusun}?
 who PIVOT {*die-PV.“NMZ”/√AV.IRR.“NMZ”-die tomorrow}
 ‘Who is the one that will die tomorrow?’
- c. m<n>sepi=ku Ø (seediq) [*huqil-un /√mp-huqil kusun].
 AV<PRF>dream=1SG.PIVOT ACC(Y) (person) [*PRF-die-PV.“NMZ”/√AV.IRR.“NMZ”-die tomorrow]
 ‘I dreamt of the one [who will die tomorrow].’

(30) *Incompatibility of unaccusative verb under PV*

- a. *pa-patay-in/√ma-ma-matay ang lalaki bukas. [Tagalog]
 IRR-die-PV/√IRR-AV-die PIVOT man tomorrow
 ‘The man will die tomorrow.’
- b. sino ang {*pa-patay-en /√ma-ma-matay bukas}?
 who PIVOT {*IRR-die-PV.“NMZ”/√IRR-AV.“NMZ”-die tomorrow}
 ‘Who is the one that will die tomorrow?’
- c. na-panaginip-an=ko ang lalaki [ng *pa-patay-en /√ma-ma-matay
 PRF-dream-LV=1SG.GEN(X) PIVOT man [LK *IRR-die-PV.“NMZ”/√IRR-AV.“NMZ”-die
 bukas].
 tomorrow]
 ‘I dreamt about the man who will die tomorrow.’

Under the Nom-into-V hypothesis, this incompatibility is unexpected and difficult to account for, especially given the fact that the Undergoer in (29)-(30) must combine with an AV affix instead. This observation suggests that the distribution of the PV affix is sensitive to the

grammatical relation of an argument, rather than simply being connected to a certain thematic role. This undermines the assumption that Philippine-type voice affixes originated from nominalizers, which are supposed to be associated with thematic roles.

On the other hand, the observation in (30)-(31) follows directly from the current analysis (24), according to which a PV affix realizes Topic-agreement with the object of a clause (see Chapters 2–5). As unaccusative verbs employ no object, they are predicted to be incompatible with a PV affix/“nominalizer”.

7.3.3.4 Issue 4: The functional diversity of synchronic voice affixes/nominalizers

Another major issue that has been overlooked by the Nom-into-V proposal is the functional diversity of the Philippine-type voice affixes, which is difficult to account for if they were derived from nominalizers.

The Nom-into-V hypothesis assumes that the three non-AV indicative affixes were derived from a nominalizer associated with a specific thematic role: patient, location, and instrument, respectively. However, as has been discussed in Chapters 3–5, the functions of these affixes are in fact far more diverse. As seen in (31), across Philippine-type languages, each of these affixes can promote multiple types of phrases to the Pivot in both root clauses and relative clauses/pseudo-clefts.

(31) *TABLE 7.4. The mapping between Pivot-selection and voice-marking in (prototypical) Philippine-type languages*

a. AV	Agent (in unergatives or 2-place clauses), Theme (in unaccusatives), Causer (in causatives), Experiencer (in statives)
b. PV	Theme (in transitives), Causee (in causatives), Recipient (in ditransitives)
c. LV	Location, Source, Goal, Temporal expression, Event (gerundives)
d. CV	Instrument, Benefactor, Theme of the caused event (in causatives), Theme (in ditransitives), Reasons, Causee, Stimulus, Arouser, Manner, Degree, Purpose

As nominalizers are crosslinguistically connected to specific thematic roles, a nominalizer origin of the Philippine-type voice affixes leaves their synchronic functional diversity hard to explain.

Under the present analysis, the functions and distributions of these voice affixes follow from the analysis presented in Chapters 3–5.

7.3.3.5 Issue 5: A perfective marker exclusively used in nominalization?

A fifth issue in the Nom-into-V hypothesis lies in the assumption that the perfective marker *<in>, along with the three non-AV affixes, was used exclusively as a marker for nominal predicates prior to the reanalysis of Nom-into-V.

This analysis has two possible interpretations, both of which suggests a proto-system that is typologically highly unusual. First, Proto-Austronesian did not have a perfective marker for verbs prior to the reanalysis. Second, Proto-Austronesian had two separate perfective markers for nominalized and verbal environments, and the former was eliminated during the purported reanalysis of Nom-into-V.

These issues, however, are not present in the current analysis, as a perfective marker is expected to be available in finite relative clauses.

7.3.4 Final remark: Against an insubordination analysis

Finally, I discuss why an insubordination analysis is inappropriate for the case of Austronesian N-V homophony.

Insubordination, or *de-subordination*, refers to the phenomenon in which previous subordinate clause structures were reanalyzed into root-clause structures (e.g., Evans & Watanabe 2007; Mithun 2008; Givón 2015). Given the current position that “nominalizers” are in fact voice affixes in relative clauses, one might argue that Austronesian N-V homophony can be analyzed as an instance of insubordination, according to which Philippine-type voice morphology was used exclusively in relative clauses and later reanalyzed into root-clause morphology.

This analysis is disfavored due to several obvious disadvantages. Firstly, it suggests an entire morphological replacement in Proto-Austronesian root-clause morphology. Further, it forces the assumption that the Philippine-type voice morphology was used only in relative clauses and not in root clauses. As the Philippine-type voice affixes inflect for mood and voice (i.e., topic-selection), assuming such distinctions to have originated in relative clauses is difficult to maintain.

7.3.5 Interim conclusion

I have argued in this section that the Nom-into-V hypothesis is a misanalysis triggered by the low frequency of non-indicative morphology in relative clauses, which creates an apparent special relation between indicative voice affixes and the voice morphology in relative clauses.

Based on the finite CP analysis of relative clauses and their compatibility with non-indicative affixes, I argued that Austronesian “N-V” homophony essentially reflects the symmetrical distribution of Philippine-type voice affixes in both root clauses and finite relative clauses.

7.4 The nature of the absence of “N-V” homophony and the directionality issues in the NAn hypothesis

Following the current analysis, I revisit the second and third assumptions of the Nuclear Austronesian hypothesis (32a)-(b), which are motivated by the interlanguage variation in “N-V homophony” summarized in (33).

- (32) a. The absence of N-V homophony in Rukai, Tsou, Puyuma, Saaroa, and Kanakanavu reflects a *retention*, which is a result of their being excluded from an archaic innovation that gave rise to N-V homophony.
- b. This innovation took place in a step-by-step manner. Saaroa and Kanakanavu split off at different stages of this reanalysis, resulting in their partial N-V homophony.

The check marks in (33) indicate the presence of “N-V” homophony; the asterisks indicate the absence of “N-V” homophony (namely, for the corresponding voice type, Grade I morphology can only appear in relative clauses and not in root clauses); the dashes indicate the absence of a certain voice distinction in the language (namely, voice affixes of a certain voice type, regardless of Grade, cannot be used in root clauses, hence the lack of a certain voice distinction).

(33) TABLE 7.5. *The variation in N-V homophony among higher-order Austronesian languages*²¹

	Perfective	PV	LV	CV
a. Rukai	—	—	—	—
b. Tsou ²²	*	*	*	*
c. Puyuma	*	*	*	*
d. Saaroa	✓	*	—	*
e. Kanakanavu	✓	✓	—	—
f. Paiwan	✓	✓	✓	✓
g. Atayalic	✓	✓	✓	✓
h. [the majority]	✓	✓	✓	✓

Under the current analysis, N-V homophony is the prototypical pattern of a Philippine-type voice system, as there should be no restriction for the Grade I (indicative) voice affixes to be present in both root clauses and relative clauses. If so, the absence of N-V homophony in (33a)-(e) would be innovative, potentially due to morphological reductions. However, this directionality is rejected by the Nuclear Austronesian hypothesis, which interprets the absence of homophony in (33a)-(e) as a *retention*.

²¹ The voice paradigm of Rukai, Tsou, Puyuma, Saaroa, and Kanakanavu will be detailedly discussed in Section 7.4.2.

²² Note that the claimed absence of N-V homophony in Tsou is in fact inaccurate. See relevant discussion in Section 7.4.3.

In this section, I demonstrate that a retention analysis for Rukai, Tsou, Puyuma, Saaroa, and Kanakanavu is difficult to maintain, which lends further support to the current account for N-V homophony. The main claim of the section is summarized in (34):

(34) *Main claim of the section*

N-V homophony is the prototypical pattern of the Philippine-type voice system, which reflects the presence of voice morphology in both root clauses and finite relative clauses. The absence of homophony reflects an *innovation*, in which root-clause morphology has undergone pattern reduction, while the conservative morphology is still preserved in subordinate clauses.

Given this conclusion, N-V homophony has no subgrouping value, as its presence does not reflect a shared innovation, but a common retention. The conflicts between Approach B and other types of subgrouping evidence discussed in Chapter 6 can thus be resolved.

I begin in 7.4.1 with a brief review of the Nuclear Austronesian hypothesis. In 7.4.2, I revisit synchronic variation in the five languages, and present novel evidence for a directionality alternative to the Nuclear Austronesian hypothesis in 7.4.3.

7.4.1 The Nuclear Austronesian hypothesis revisited

In principle, the synchronic absence of N-V homophony in a language allows two diachronic interpretations:

- (35) a. Scenario I: N-V homophony never existed in the language.
b. Scenario II: N-V homophony was lost in the language.

As the absence in each of the five languages (33a)-(e) allows two possibilities, a total of 2^5 (=32) diachronic scenarios is logically possible. Ross (2009, 2012) and subsequent works has assumed a scenario in which the absence in all the five languages reflects a *retention*, as a result of their being excluded from the emergence of N-V homophony. This analysis gives rise to the subgrouping in (36):

(36) FIGURE 7.2. Revised Nuclear Austronesian hypothesis under Zeitoun & Teng (2016)

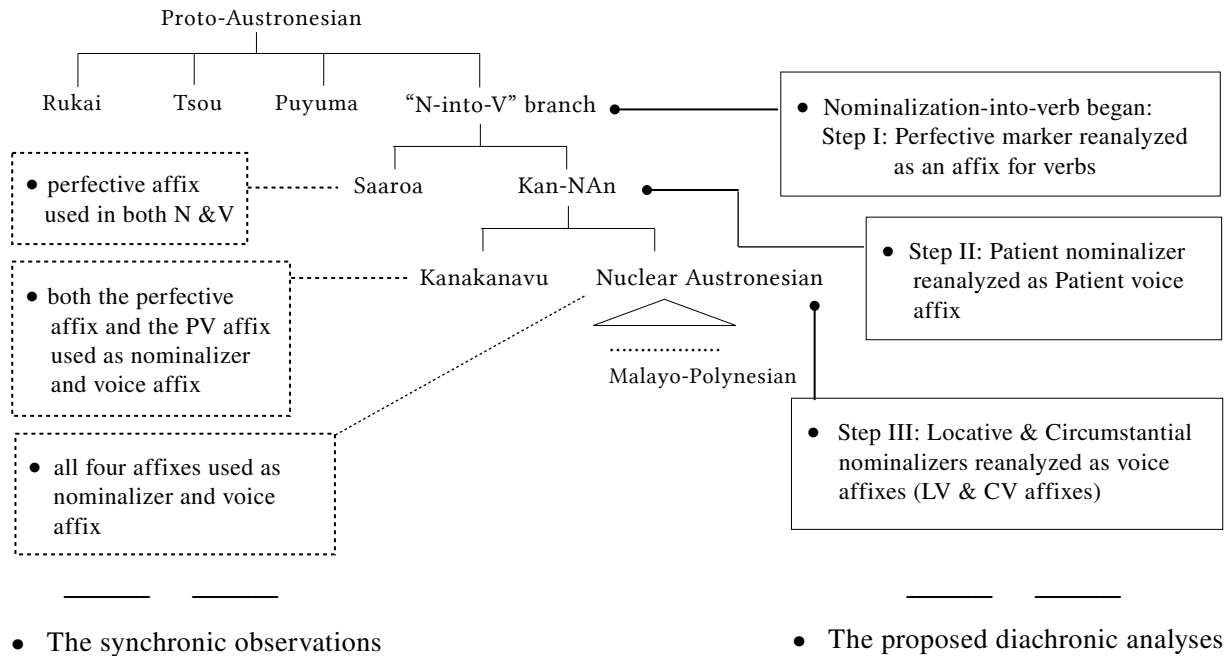

As shown above, Rukai, Tsou, and Puyuma are analyzed as three primary-level offshoots excluded from the innovation of N-V homophony. Saaroa is claimed to be the first offshoot of the innovative branch, under the assumption that it split off at the beginning stage of “Nom-into-V” with only the reflex of the perfective affix for nominals reanalyzed into a verbal affix.²³ Kananavu is placed at the second level, under the assumption that it split off after the patient nominalizer **-un* was reanalyzed as a Patient voice affix. The rest of the languages fall under the Nuclear Austronesian subgroup at the bottom, defined by the purported completion of the innovation of N-V homophony.

In sum, the Nuclear Austronesian hypothesis relies crucially on the assumption that *the presence of N-V homophony reflects a single innovation that excluded Rukai, Tsou, Puyuma, Saaroa, and Kananavu*. Therefore, if the absence of N-V homophony in any of these languages is not a retention, the presence of N-V homophony has no subgrouping value—as it reflects the Proto-Austronesian pattern.

7.4.2 The synchronic facts revisited

In what follows, I revisit the synchronic facts behind the Nuclear Austronesian hypothesis, and argue for an alternative directionality for the absence of N-V homophony.

²³ In other words, it is assumed that the perfective affix **<in>* was used exclusively in relative clauses prior to the purported reanalysis.

Descriptively, the absence of N-V homophony refers to the phenomenon in which *the Grade I (indicative) voice affixes are not present in both root clauses and relative clauses*—the latter includes headless relative clauses used in pseudo-clefts and lexicalized nominals, which are conventionally regarded as nominalizations.

What lies behind this generalization is a great variation in how the absence is manifested. In languages that present a prototypical Philippine-type voice system, all voice distinctions are available in both root clauses and relative clauses and with mood inflections, as in Seediq (37):

(37) TABLE 7.6. *Seediq voice morphology*²⁴

	AV	PV	LV	CV	Etyma
<i>“Nominalization”</i>					
... Indicative	<i>M-√</i>	<i>√-un</i>	<i>√-an</i>	<i>s-√</i>	Proto-Austronesian Grade I
... Negative	<i>√-∅</i>	<i>√-i</i>	<i>√-i</i>	<i>√-ani</i>	Proto-Austronesian Grade III
<i>Root clause</i>					
... Indicative	<i>M-√</i>	<i>√-un</i>	<i>√-an</i>	<i>s-√</i>	Proto-Austronesian Grade I
... Hortative	<i>√-∅</i>	<i>√-e/-o</i>	<i>√-e/-o</i>	?	Proto-Austronesian Grade II
... Imp./Neg.	<i>√-∅</i>	<i>√-i</i>	<i>√-i</i>	<i>√-ani</i>	Proto-Austronesian Grade III

In Rukai, however, Philippine-type voice morphology is observed only in relative clauses, except for fossilized AV morphology in the root clauses of conservative dialects, as in (38).²⁵ Therefore, Rukai is conventionally thought to lack Philippine-type morphosyntax.

(38) TABLE 7.7. *Proto-Rukai voice morphology*²⁶

	AV	PV	LV	CV	Etyma
<i>“Nominalization”</i> ²⁷					
... Indicative	<i>M-√</i>	<i>√-anə</i>	<i>ta-√-anə</i>	<i>sa-√</i>	Proto-Austronesian Grade I
<i>Root clause</i>					
... Indicative	<i>M-√</i>	—	—	—	
... Subjunctive	<i>M-√</i>	—	—	—	
... Imperative	<i>M-√-a</i>	—	—	—	

²⁴ Sources: primary data on Tgdaya Seediq, with reference to Tsukida (2009) on Truku Seediq. The absence of a hortative series in “nominalization” is due to the fact that a hortative mood is not possible in relative clauses.

²⁵ The AV affix *M-* is found in Tanan and Budai, but is almost unattested in Mantauran (Zeitoun 2000b, 2007, 2016).

²⁶ Source: P. Li (1977)

²⁷ The label ‘*nominalization*’ refers to voice morphology present in relative clauses.

In Tsou, both the Grade I and Grade III affixes are synchronically unattested. The system functions only with the Grade II affixes, which are used in both root clauses and relative clauses. Therefore, modern Tsou morphology lacks a mood distinction.

(39) TABLE 7.8. *Tsou voice morphology*²⁸

	AV	PV	LV	CV	Etyma
“Nominalization”	<i>M-√</i>	<i>√-a</i>	<i>√-i</i>	<i>√-(n)eni</i>	Proto-Austronesian Grade II
<i>Root clause</i>	<i>M-√</i>	<i>√-a</i>	<i>√-i</i>	<i>√-(n)eni</i>	Proto-Austronesian Grade II

In Puyuma, the Grade I affixes are restricted to relative clauses (except for the AV affix). In root clauses, the indicative mood is marked by the Grade II affixes—which are typically used in optative/hortative clauses in other languages. Therefore, Puyuma’s root clauses lack a morphological distinction between the indicative mood and hortative mood, as in (40):

(40) TABLE 7.9. *(Proto-)Puyuma voice morphology*²⁹

	AV	PV	LV	CV	Etyma
“Nominalization”					
... Indicative	<i>M-√</i>	<i>√-en</i>	<i>√-an</i>	<i>i-√</i>	Proto-Austronesian Grade I
... Negative	<i>√-∅</i>	<i>√-u</i>	<i>√-i</i>	<i>√-an</i>	Proto-Austronesian Grade III
<i>Root clause</i>					
... Indicative	<i>M-√</i>	<i>√-aw</i>	<i>√-ay</i>	<i>√-anay</i>	Proto-Austronesian Grade II
... Hortative	<i>M-√</i>	<i>√-aw</i>	<i>√-ay</i>	<i>√-anay</i>	Proto-Austronesian Grade II
... Imp./Neg.	<i>√-∅</i>	<i>√-u</i>	<i>√-i</i>	<i>√-an</i>	Proto-Austronesian Grade III

In Saaroa, the Grade I LV affix is used only in relative clauses (41). Since this affix is not attested in root clauses, Saaroa is described as a language with only a three-way voice distinction.

²⁸ Source: Tsuchida (1976)

²⁹ This reconstruction relies on the preservation of PV *-en* in Tamalakaw and Katripul Puyuma.

(41) TABLE 7.10. Saaroa voice morphology³⁰

	AV	PV	LV	CV	Etyma
<i>“Nominalization”</i>					
... Indicative realis	?	√-a(na)	ta-√-a(na)	si-√	Proto-Austronesian Grade I
... Indicative irrealis	?	a-√-a(na)	—	a-√-ani	Proto-Austronesian Grade II
<i>Root clause</i>					
... Indicative	M-√	√-a	—	√-ani	Proto-Austronesian Grade II
... Imperative	M-√-a	√-u	—	√-ani	Proto-Austronesian Grade III ^(?)
... Dependent	M-√	√-i	—	√-i	Proto-Austronesian Grade III ^(?)

In Kakanavu, the Grade I LV and CV affixes are used exclusively in relative clauses. Since these affixes cannot appear in root clauses, Kakanavu is described as exhibiting only a two-way voice distinction, as in (42):

(42) TABLE 7.11. Kakanavu voice morphology³¹

	AV	PV	LV	CV	Etyma
<i>“Nominalization”</i>					
	ta-, M-	√-an	ta-√-an	si-√	Proto-Austronesian Grade I
<i>Root clause</i>					
... Indicative	M-√	√-an,	—	—	Proto-Austronesian Grade I
... Imperative	M-√-a	√-(a)u	—	—	Proto-Austronesian Grade III
... Dependent	M-√	√-(a)i	—	—	Proto-Austronesian Grade III

To sum up, all five of these languages share a phenomenon in which *the voice morphology used in root clauses shows fewer distinctions than that in relative clauses*. The important question that concerns us here is whether this phenomenon reflects an innovation or a retention.

If it reflects a retention—as argued in the Nuclear Austronesian hypothesis—Proto-Austronesian had more mood distinctions in relative clauses than in root clauses, which is crosslinguistically rare. Alternatively, if this phenomenon is *not* a retention, it implies that the root clause morphology in these languages is more innovative than that in relative clauses—an implication that follows straightforwardly from the crosslinguistic generalizations that *main clauses are innovative, subordinate clauses are conservative* (e.g., Vennemann 1975; Matsuda 1993; 1998; Hock 1986; Aldai 2000; Bybee & Thompson 2000; Bybee 2001)—due to differential frequency.

In what follows, I present evidence for the second scenario, showing that it is favored not only for its compatibility with general theory, but also for its superior account of the synchronic facts.

³⁰ Source: Zeitoun & Teng (2016)

³¹ Source: Zeitoun & Teng (2016)

7.4.3 Evidence for a unitary directionality of loss

7.4.3.1 Possessor-genitive homophony and a Pivot-only constraint in Puyuma and Tsou

As discussed in 7.3.1, advocates of the Nuclear Austronesian hypothesis have associated two common traits of Philippine-type languages with the emergence of N-V homophony: (i) possessor-genitive homophony, and (ii) a Pivot-only constraint in A'-extraction, which is attributed to a ban on extracting genitive (i.e., X-marked) agents. If the absence of N-V homophony in Rukai, Tsou, and Puyuma indeed reflects their being excluded from the emergence of N-V homophony, none of these language should exhibit (i)-(ii).

However, both (i)-(ii) are observed in Puyuma and Tsou. As seen in (43)-(44), both exhibit homophony between possessor-marking and the marking for non-Pivot agents.

(43) TABLE 7.12. *Possessor-genitive (X) homophony in Puyuma*³²

	Personal name				Common noun			
	Singular		Plural		Definite		Indefinite	
	Poss	Gen (X)	Poss	Gen (X)	Poss	Gen (X)	Poss	Gen (X)
Nanwang	<i>kan</i>	<i>kan</i>	<i>kana</i>	<i>kana</i>	<i>kana</i>	<i>kana</i>	<i>dra</i>	<i>dra</i>
Katripul	<i>ni</i>	<i>ni</i>	—	—	<i>(ni)na</i>	<i>(ni)na</i>	<i>za</i>	<i>za</i>
Uvivelivek	<i>ni</i>	<i>ni</i>	—	—	<i>(ni)na</i>	<i>nina</i>	<i>za</i>	<i>za</i>

(44) TABLE 7.13. *Possessor-genitive (X) homophony in Tsou*³³

	+ identifiable, -referential			Common noun	
	visible, proximal	visible, medial	visible, distal	-visible, high certainty	-visible, low certainty
Nominative	<i>'e</i>	<i>si</i>	<i>ta</i>	<i>'o</i>	<i>na</i>
Oblique/possessive	<i>ta</i>	<i>ta</i>	<i>ta</i>	<i>to</i>	<i>no, ne</i>

Furthermore, both Tsou and Puyuma exhibit a Pivot-only constraint in A'-extraction. The same constraint is attested in relative clauses in Rukai (Li 1973) and the PV and CV clauses of Saaroa. All of these languages and the relevant constructions in Saaroa are excluded from the innovation of “Nom-into-V”, but the presence of these features in them clearly undermines the hypothesis.

³² Source: Teng (2009).

³³ Source: Lin 2010:99; Zeitoun 2005:274.

Alternatively, if the absence of N-V homophony in all five languages results from morphological reductions, the presence of these two traits can be explained as a retention of the prototypical pattern of the Philippine-type voice system.

7.4.3.2 The synchronic system of Kanakanavu and Rukai: Signs for a “loss” scenario

Further, a closer look at the synchronic morphology of Kanakanavu and Rukai points directly to a loss scenario.

Under the Nuclear Austronesian hypothesis, Kanakanavu is analyzed as the second offshoot of the “Nom-into-V” branch. As seen in (42), the language synchronically lacks the LV and CV affixes in root clauses. This two-way voice system is necessarily analyzed as a product of independent loss, since it is implausible that it was retained from Proto-“Nom-into-V”. As both Puyuma and Tsou as well as the “Nuclear Austronesian” languages at the bottom of the “Nom-into-V” branch exhibit a four-way voice system characterized by a Pivot-only constraint in A'-extraction, it is highly unlikely that Proto-“Nom-into-V” exhibited a two-way voice system, and later a four-way system reemerged in Proto-Nuclear Austronesian.

As the lack of the LV and CV distinction in Kanakanavu must be analyzed as a result of independent loss, it undermines the core assumption of the Nuclear Austronesian hypothesis, that the absence of N-V homophony is unitarily a result of *retention*. The position of Kanakanavu is thus indecisive under the Nuclear Austronesian hypothesis.

A similar issue applies to Rukai, which has Grade I LV and CV affixes only in relative clauses. If Proto-Austronesian had a four-way voice system, the absence of voice distinctions in Rukai's root clauses is necessarily analyzed as a consequence of loss. This creates a parallel with Kanakanavu, both pointing to an innovative analysis in losing N-V homophony. Given these two cases, the foundation of the Nuclear Austronesian hypothesis is difficult to maintain.

7.4.3.3 “N-V homophony” in Grade II/III affixes: Tsou, Puyuma, and Saaroa

Further, an important fact that has been overlooked in previous work is the presence of nominalizer-voice affix homophony in Tsou—although the homophony is manifested with Grade II affixes. This is seen in (45):

(45) *Nominalizer-voice affix homophony in Tsou*

- | | | | | | | | | | | |
|----|---|-----|-------|--------------------|--|---------------|--------|----------|----------------|---------------|
| a. | zou | sia | na | [i-si | | ait-i | ta | pasuya)? | [pseudo cleft] | |
| | EMPH | who | PIVOT | [NAV.LS-3SG.GEN(X) | | see-LV.GRADE2 | GEN(X) | Pasuya] | | |
| | 'Who is the one that Pasuya saw?' (Chang Y.-Y 2003:169) | | | | | | | | | |
| | | | | | | | | | | |
| b. | i-si | | | ait-i | | ta | pasuya | 'o | 'avai. | [root clause] |
| | NAV.LS-3SG.GEN(X) | | | see-LV.GRADE2 | | GEN(X) | Pasuya | PIVOT | 'Avay | |
| | 'Pasuya saw 'Avay.' | | | | | | | | | |

As seen above, Tsou uses Grade II affixes both in root clauses and relative clauses. In the conventional terminology, they function as both voice affixes and “nominalizers”. This observation raises a serious challenge to the Nuclear Austronesian hypothesis, since Tsou must have undergone “Nom-into-V”—but with a different set of affixes.

However, the presence of nominalizer-voice affix homophony in Tsou is not an issue for the present analysis, which assumes extensive loss of both Grade I and III affixes, with the remaining voice morphology used in all clausal environments.

Parallel to this observation in Tsou, both Puyuma and Saaroa exhibit “N-V” homophony with the non-indicative voice affixes (46)-(47), raising a similar issue for the Nuclear Austronesian hypothesis:

(46) *Grade III LV affixes in both root clauses and relative clauses: Puyuma*

- a. (amaw) i senten na [RC adri ku=pukpuk-i].
 (EMPH) SG.PIVOT Senten PIVOT [RC NEG 1SG.GEN(X)=beat-LV.GRADE3]
 ‘Senten is the one that I didn’t beat.’ (Jiang 2016:189)
- b. adri ku=pukpuk-i i senten.
 NEG 1SG.GEN(X)=beat-**GRADE3** SG.PIVOT Senten
 ‘I did not beat Senten.’ (Jiang 2016:188)

(47) *Nominalizer-voice affix homophony in Saaroa Grade II affix*

- a. vur-**ani**=cu=a=ailhaku a sulhatu uluku.
 give-CV.**GRADE2**=COS=1SG.GEN(X) PIVOT book Eleke
 ‘I gave the book to Eleke.’
- b. lhi-vur-**ani**
 PRF-give-CV.**GRADE2**, “NMZ”
 ‘what was given’ (Zeitoun & Teng 2016; glosses mine)

The presence of N-V homophony in all three languages excluded from the process of “Nominalization-into-verb” strongly suggests that the “nominalizer”/“voice affix” distinction is only terminological, and that both are voice affixes—which are free to occur in both root clauses and relative clauses.

7.4.3.4 Proto-Austronesian morphosyntax under the competing hypotheses

Finally, it is noteworthy that the Nuclear Austronesian hypothesis assumes a Proto-Austronesian system with several asymmetries that are difficult to explain.

Supporters of the Nuclear Austronesian hypothesis have proposed that Proto-Austronesian had only a three-way voice distinction in indicative clauses (Ross 2012, Aldridge 2016), due to the fact that none of the three primary branches under this hypothesis exhibit a reflex of the indicative

Patient voice affix *-en (Grade I). A reflex of PV *-en is also unattested in the first offshoot of the “Nom-into-V” branch, as illustrated below:

(48) FIGURE 7.3. The presence or absence of a reflex of *-en

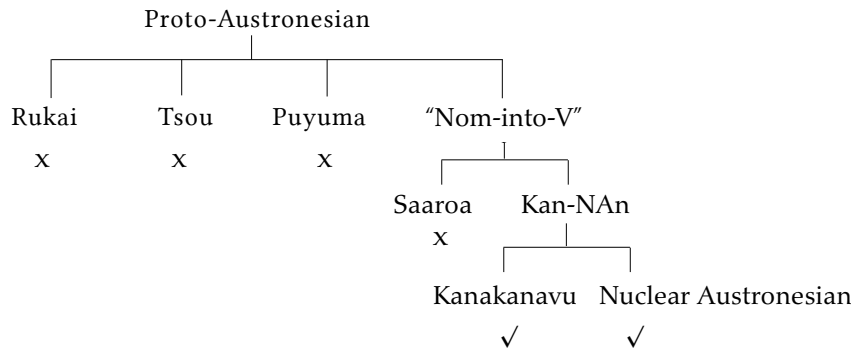

Following the logic of the Nuclear Austronesian hypothesis, which assumes that the synchronic absence of a feature must be a *retention*, it has been proposed that Proto-Austronesian was a system with only the AV, LV, and CV affixes in Grade I, as in (49). It is further assumed that the Locative voice affix functioned as a general undergoer nominalizer in Proto-Austronesian, and the indicative Patient voice affix *-en was innovated at the Proto-Nuclear Austronesian level, creating a new voice distinction in root clauses (Ross 2012:1264,1268–69; Aldridge 2016:36–37).

This proposal, however, creates an obvious asymmetry in voice distinction between the Grade I (indicative) affixes and Grades II/III affixes, as seen in (49). This asymmetry is especially disfavored as it implies a Proto-Austronesian system with more voice distinctions in non-indicative moods than indicative clauses, which is typologically anomalous.

(49) Table 7.14. Pre-P-“Nom-into-V” morphology under Ross (2012) and Aldridge (2016)

	AV	PV	LV	CV	
“Nominalization”	— ³⁴	√-an	√-an	Si-/Sa-√	(Grade I)
<i>Root clause (V)</i>					
... Indicative	M-√	(not reconstructable)			
... Opt./Hor.	M-√-a	√-aw	√-ay	√-anay	(Grade II)
... Imp./Neg.	√-∅	√-u	√-i	√-an	(Grade III)

Further, as discussed in Section 7.1.3, under the replacement-type reanalysis adopted in the Nuclear Austronesian hypothesis, the indicative voice morphology of Proto-Austronesian is not

³⁴ As discussed in Section 7.3, both Ross and Aldridge assume that the AV affix cannot serve as a nominalizer. This assumption is, however, inaccurate.

reconstructable—as none of the three primary branches can provide evidence for the form of the indicative affixes due to their lack of a Grade I/Grade II distinction.

By contrast, the present analysis suggests a Proto-Austronesian system with no gap or morphological asymmetry among the three grades, as in (50):

(50) TABLE 7.15. *The Proto-Austronesian voice system under the present analysis*

	AV	PV	LV	CV	(in both root clauses and relative clauses)
a. Grade I	*<um>	*-en	*-an	*Si-/Sa-	indicative
b. Grade II	*-a	*-aw	*-ay	*-anay	optative, hortative
c. Grade III	*-∅	*-u	*-i	*-an	imperative, negative

The economy of this proposal will be further discussed in Section 7.5.

7.4.4 A note on possessor-X homophony

Before concluding, the question how the present analysis accounts for the phenomenon of “possessor-genitive homophony” deserves a separate discussion.

Descriptively, “possessor-genitive homophony” refers to the phenomenon in which the marking of possessors is homophonous with that for non-Pivot agents in PV, LV, and CV clauses. As the Nominalization-into-verb hypothesis is seen to be untenable, this homophony cannot be attributed to a derivational relation, but needs to be considered as a fact of the Philippine-type voice system.

Given the analysis in Chapters 2–5, “possessor-genitive homophony” reflects homophony between nominative case and possessive marking. This phenomenon is not typologically unknown, as it is observed also in Latvian (Halle 1992), Nganasan (Nichols 2013; Helimski 1998) and Hungarian (Bielecki 2011), as well as in some specific environments in Finnish (Lyle Campbell, p.c.).

7.5 Where’s the old morphology? In relative clauses.

I have demonstrated in the preceding section that the absence of N-V homophony in several highest-order languages is difficult to account for under a retention account. In this section, I present additional evidence for the view that this absence is invariably due to innovation.

7.5.1 Root clauses are innovative, subordinate clauses are conservative.

It was noted in 7.4 that morphological changes in root clauses are not immediately duplicated in subordinate clauses, as seen in word order change in Old English (Hock 1986), German (Vennemann 1975; Givón 1979), and Kru (Givón 1979), as well as in grammaticalization (Klein-Andreu 1990; Bybee et al. 1994), morphological replacement (Aldai 2000), and morphophonemic change (Matsuda 1993, 1998).

This generalization is also well-attested in Malayo-Polynesian languages, where the Philippine-type voice affixes were lost in root-clause morphology, with fossilized affixes preserved in lexicalized nominals formed by a headless relative clause.³⁵ Under the present analysis, the variation in N-V homophony among Formosan languages provides another striking parallel, suggesting that Philippine-type languages are moving toward morphological simplification, starting with root clauses. In what follows, I discuss several parallel examples in extra-Formosan languages.

7.5.2 Extra-Formosan parallels

It is unambiguous that lower-level Austronesian languages have undergone extensive innovations and lost the Philippine-style voice system. While languages in Borneo, Indonesia, and Sulawesi preserve a remnant two-way voice distinction, the voice distinctions are gone without a trace in others (Blust & Chen 2017). Even within languages that still preserve Philippine-type syntax, the move toward eventual loss can be clearly observed.

Tukang Besi is a Malayo-Polynesian language spoken in southeast Sulawesi. Synchronically, the Philippine-type voice affix is no longer used productively in its root clauses (51a). However, in relative clauses, the Philippine-type voice affix is obligatorily present, as seen in the pseudo-cleft example (51b). This observation signals a loss in root-clause morphology that is still preserved in relative clauses.

(51) *Grade I morphology preserved in Tukang Besi pseudo-clefts*

- a. no-**balu** te loka na wawine.
3.RLS-**buy** CORE banana NOM woman
'The woman bought some bananas.'
- b. Te emai na [**b<um>alu** te loka]?
CORE who NOM [**<AV>buy** core banana]
'Who bought the bananas?' (Donohue 1999)

³⁵ For instance, the Malayo-Polynesian language Roviana presents no Philippine-type voice morphology in root clauses. However, voice affixes are still used as nominalizers in the language, including the reflex of the perfective affix *<in> and the locative affix *-an, as in *gani* 'eat' : *g<in>ani* (< PAn PV *<in>√-Ø) 'thing eaten, food', *huhuve* 'bathe' : *huhuve-ana* (< PAn *-an) 'bathing place'.

Similar to *Tukang Besi*, Chamorro has lost productive voice affixes in root clauses. However, reflexes of the Grade I affixes are obligatorily present in relative clauses and pseudo-clefts, which are analyzed synchronically as *wh*-agreement (Chung 1994, 1998). As seen in (52a), in ordinary complementation, the embedded clause does not carry a voice affix. However, a voice affix <um> is obligatory in the presupposed clause of pseudo-cleft in (52b), which is structurally a headless relative.

(52) *Grade I morphology preserved in Chamorro pseudo-clefts*

- a. h<um>ällum si Maria [na ha-**pänak** si Juan i pätgun].
 AGR.assume PN Maria [C AGR-**spank** PN Juan the child]
 ‘Maria assumes that Juan spanked the child.’
- b. Hayi h<in>aomña si Maria [p<um>änak ____ i pätgun]?
 who <PV>assume PN Maria [<AV>spank ____ the child]
 ‘Who does Maria assume spanked the child?’ (Chung 1994:1, glosses mine)

As both *Tukang Besi* and Chamorro are descendants of Proto-Malayo-Polynesian—which unambiguously exhibited Philippine-type voice morphology in root clauses, the absence of root-clause morphology in these two languages is uncontroversially a consequence of secondary innovations. This is parallel to *Rukai*, in which the Philippine-type voice affixes are used only in relative clauses.

Importantly, the fact that Chamorro and *Tukang Besi* are not closely related suggests that the observed directionality may be a common tendency of Philippine-type languages. Similar phenomena, are also attested in the Formosan languages *Kanakanavu*, *Kavalan*, and *Bunun*. See Blust & Chen (2017) for details.

7.5.3 Support from the Economy Principle

Finally, as noted in Section 7.2.4, a diachronic proposal that requires the smallest number of changes to derive the synchronic picture is optimal. Before closing this chapter, it is noteworthy that the present analysis indeed assumes fewer innovations than the conventional account.

In (53) and (54), I summarize the required changes under the current analysis and under the Nuclear Austronesian hypothesis. Changes marked with an asterisk indicate innovations that are highly unlikely.

(53) TABLE 7.16. Required innovations under the current analysis

	Required changes	Relevant discussion
Tsou	1 entire loss of Grades I and Grade III affixes in all environments (except Grade I AV)	Section 7.4.2
Rukai	1 loss of voice distinction in root-clause morphology except fossilized AV affixes in conservative dialects 2 loss of Grade I PV affix *-en in relative clauses	Section 7.4.2
Puyuma	1 loss of Grade I affixes in root clause morphology (except Grade I AV)	Section 7.4.2
Saaroa	1 loss of Grade I LV affix in root-clause morphology	Section 7.4.2
Kanakanavu	1 loss of Grade I LV/CV affixes in root-clause morphology	Section 7.4.2

(54) TABLE 7.17. Required innovations under the Nuclear Austronesian hypothesis (Approach B)

	Required changes	Relevant discussion
Tsou	1 independent innovation of possessor-genitive homophony* 2 independent innovation of the “Pivot-only” extraction constraint* 3 independent innovation of N/V homophony in all Grade II affixes* 4 loss of Grade I affixes in “nominalized” environment (except AV)	Section 7.4.3.1 Section 7.4.3.1 Section 7.4.3.3 Section 7.4.2
Rukai	1 loss of all voice distinctions in root-clause morphology	Section 7.4.2
Puyuma	1 independent innovation of possessor-genitive homophony* 2 independent innovation of the Pivot-only extraction constraint* 3 independent innovation of N/V homophony in Grade III affixes* 4 independent innovation of N/V homophony in Grade I AV affix* 5 reanalyze Grade II (hortative) affixes into indicative voice affixes	Section 7.4.3.1 Section 7.4.3.1 Section 7.4.3.3 Section 7.3.3.2
Saaroa	1 loss of Grade I LV affix in root-clause morphology 2 independent innovation of a Pivot-only extraction constraint in AV, PV, and CV clauses*	Section 7.4.2 Section 7.4.3.1
Kanakanavu	1 loss of Grade I LV/CV affix in root-clause morphology 2 independent innovation of a Pivot-only constraint in AV clauses*	Section 7.4.2 Section 7.4.3.1
“Nom-into-V” branch	1 innovation of a new “nominalizer”, i.e., the Patient nominalizer* 2 innovation of Nominalization-into-verb 3 independent innovation of N-V homophony in AV* 4 innovation of a Pivot-only constraint in AV clauses*, or 4’ loss of Possessor-genitive homophony in AV clauses*	Section 7.4.3.4 Section 7.3.2 Section 7.3.3.2 Section 7.3.3.2 Section 7.3.3.2

As seen above, the present analysis requires far fewer innovations than the Nuclear Austronesian hypothesis, lending further support to its superiority in accounting for Austronesian N-V homophony.

7.6 Conclusion

In this chapter, I have argued that Austronesian nominalizer-voice affix homophony reflects Philippine-type voice affixes present in both root clauses and finite relative clauses. Following this analysis, I have demonstrated that the synchronic absence of N-V homophony in several higher-order Austronesian languages is best analyzed as a consequence of independent pattern reductions. I conclude therefore that the presence of N-V homophony is not a valid approach to Austronesian primary-level subgrouping, as it reflects the prototypical pattern of the Proto-Austronesian voice system.

This analysis has also presented an alternative to the nominalism approach to Philippine-type voice morphology (Kaufman 2009, 2017). Under the present position, Philippine-type voice morphology has been “verbal” since the beginning, and so always appears on verbs and realizes topic-indicating agreement that inflects for voice (topic-selection) and mood.

Chapter 8

Conclusion

In this dissertation, I have investigated three central questions in Austronesian linguistics (1a)-(c) by reexamining the core syntax of four Philippine-type languages (Puyuma, Amis, Seediq, Tagalog) from different Austronesian primary branches:

- (1) a. What is the nature of the Philippine-type voice system, with regard to its argument-marking mechanism, case alignment, and four-way verbal morphology?
- b. What is the nature of the homophony between Philippine-type *voice affixes* and their functionally corresponding *nominalizers* used in relative clauses?
- c. Are the synchronic interlanguage variations in (i) *nominalizer-voice affix homophony* or (ii) *Philippine-type voice distinctions in root clauses* among higher-order Austronesian languages reliable means for subgrouping?

In this chapter, I summarize my account of these three questions presented in Chapters 2–7 (Section 8.1) and discuss their main implications (Section 8.2).

8.1 A recapitulation of the main claims of this study

Philippine-type Austronesian languages show apparent phenomena of syntactic ergativity, whereby the external argument in AV clauses patterns with the internal argument in PV clauses in both argument marking (i.e., “Pivot”) and A’-extraction eligibility, as in (2). Under the conventional analysis (e.g., Payne 1982; Mithun 1994; Aldridge 2004; Liao 2004), the marker X realizes ergative case, and the marker Y realizes oblique case that marks non-core objects. In this view, the subject of intransitives (S) (2a) shares the same morphological marking with the object of transitives (O) (2b):

(2) *TABLE 8.1. The basic argument-marking pattern in Philippine-type AV and PV clauses*

	a. Actor voice (AV)	b. Patient voice (PV)
External argument	Pivot	X
Internal argument	Y	Pivot

In this dissertation, I argued that this seemingly ergative pattern in (2) is an illusion created by the combination of prominent topic marking and an accusative case system. In Chapters 2 and 3, I demonstrated that the distributions of the markers X and Y show the hallmarks of nominative and accusative Case, respectively. I then showed in Chapter 4 that the marker “Pivot” cannot plausibly be analyzed as marking structural nominative/absolute Case, as it may appear on both (i) arguments that are structurally low in a clause and (ii) adjuncts. Applying binding diagnostics to Puyuma, Amis, Seediq, and Tagalog, I showed that the alternation in Pivot-selection among clauses of different voice types is not accompanied by a change in clause structure. This suggests that the licensing of “Pivot”-marking does not respect the locality condition of nominative/absolute Case-licensing. I concluded accordingly that Philippine-type Austronesian languages do not exhibit ergativity at either the morphological or syntactic level.

In Chapter 5, I demonstrated that “Pivot”-marking in Puyuma, Amis, Seediq, and Tagalog is best analyzed as a topic marker that overlays morphological case. The argument-marking mechanism of Philippine-type languages suggested by the current analysis of Pivot, X, and Y is illustrated in (3):

(3) *TABLE 8.2. Proposal: the argument-marking mechanism of the Philippine-type voice system*

	a. Actor voice	b. Patient voice	
External argument	Nominative “Topic”	Nominative	X = Nominative
Internal argument	Accusative	Accusative “Topic”	Y = Accusative

Building on the topic analysis of “Pivot”-marking in (3) (Section 5.2), I investigated the nature of the four-way distinction of Philippine-type voice morphology in Section 5.3. The empirical mapping between voice-marking and the distribution of the “Pivot” marker in basic transitive constructions in Philippine-type languages is illustrated in (4):

(4) *TABLE 8.3. The shared argument-marking pattern among Philippine-type languages*

	a. AV	b. PV	c. LV	d. CV
External argument	Pivot	X	X	X
Internal argument	(Y)	Pivot	(Y)	(Y)
Location	(Loc)	(Loc)	Pivot	(Loc)
Instrument/benefactor	(Y)	(Y)	(Y)	Pivot

I demonstrated that these four affixes are best analyzed as the spell-out of four different bundles of Agree relations with the topic of a clause:

- a. **“AV”-morphology** is the morphological reflex of the bundle of topic-agreement and Subject-agreement (ϕ -agreement).

“AV”-morphology appears when the nominative phrase in a clause is the topic (i.e., the Pivot).

This analysis correctly predicts that possible Pivots in AV-marked clauses include (i) the external argument in transitive or unergative clauses, as well as (ii) the internal argument in stative or unaccusative clauses.

- b. **“PV”-morphology** is the morphological reflex of the bundle of topic-agreement and Object-agreement (Chomsky 2000, 2001b; Pesetsky & Torrego 2006; Baker 2012). The latter is an abstract Agree relation between Voice⁰ and the highest argument within the matrix VoiceP in a clause.

“PV”-morphology appears when a direct object is the topic of a clause. This includes (i) the internal argument in simple transitive clauses, (ii) the Causee in productive causatives, and (iii) the Recipient in double-object ditransitives.

- c. **“LV”-morphology** is the morphological reflex of the bundle of topic-agreement and an Agree relation between a special type of preposition (i.e., Proto-Austronesian temporal/locative marker *i (Blust 2013)) and its complement, which must be a temporal or locative phrase.

“LV”-morphology appears when a temporal/locative phrase (licensed by this special preposition, which cannot select other types of phrases as its complement) is the topic of a clause.

- d. **“CV”-morphology** is the morphological reflex of simple topic-agreement.

“CV”-morphology appears when a phrase other than subject, direct object, or temporal/locative phrase is the topic of a clause. This includes arguments that are structurally low (e.g., a Causee in productive causatives and a Theme in double-object ditransitives) and adjuncts that are not temporal/locative phrases (e.g., Instrument, Benefactor, Reason, Stimulus).

Building on this analysis, I argued in Section 5.5 that Philippine-type languages are best characterized as *topic-prominent languages* (Li & Thompson 1976) or *discourse configurational languages* (Kiss 1995; Miyagawa 2010, 2017), whose topic-prominent nature is manifested both in (i) prominent topic-marking and (ii) articulated verbal morphology that indicates the Agree relations of the topic in a clause.

I concluded in Chapter 5 that Philippine-type languages are best analyzed as hosting a topic-feature on C and the ϕ -feature on T, with topic-agreement spelled-out as verbal morphology. The design of the Philippine-type voice system under this analysis is illustrated in (5):

(5) *Proposal: the design of the Philippine-type voice system*

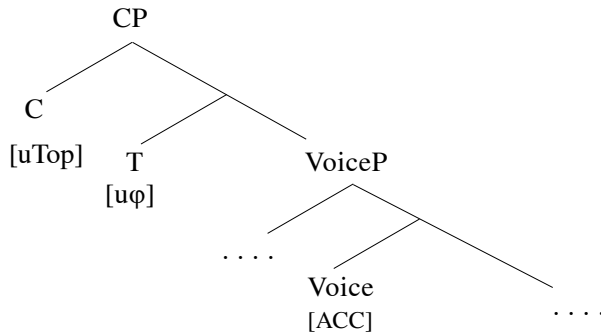

In the second half of the study (Chapters 6–7), I demonstrated how this analysis of the synchronic syntax of Philippine-type languages enables a simpler solution to two central questions in Austronesian diachronic linguistics (6a)-(b):

- (6) a. What is the nature of the homophony between Philippine-type voice affixes and their functionally corresponding nominalizers in relative clauses?
- b. Are phonological innovations or the morphosyntactic variation among higher-order Austronesian languages in (i) the presence or absence of *nominalizer-voice affix homophony* or (ii) the presence or absence of *Philippine-type voice distinctions in root clauses* better evidence for Austronesian primary-level subgrouping?

Building on the synchronic syntactic analyses summarized above, I argued in Chapter 7 that the presence of (i) and (ii) does not constitute valid evidence for Austronesian primary-level subgrouping, as the absence of both features reflects independent morphological erosions in innovative languages. This explains why previous subgroupings that assume the presence of (i)-(ii) to be a *shared innovation* (Ross 2009, 2012; Aldridge 2016; Zeitoun & Teng 2016) are in conflict with phonological/lexical evidence for subgrouping, as well as the homeland implied by archeological record and the sociocultural classifications of Formosan tribes (Chapter 6).

I concluded in Chapter 7 that phonological innovations constitute better evidence for Austronesian primary-level subgrouping than the two types of morphosyntactic variation found between higher-order Philippine-type languages (i)-(ii). This conclusion suggests that the Austronesian language family is comprised of at least 10 primary branches, as in (7):

(7) *FIGURE 8.1. Austronesian primary-level subgrouping evidenced by sound changes (Blust 1999)*

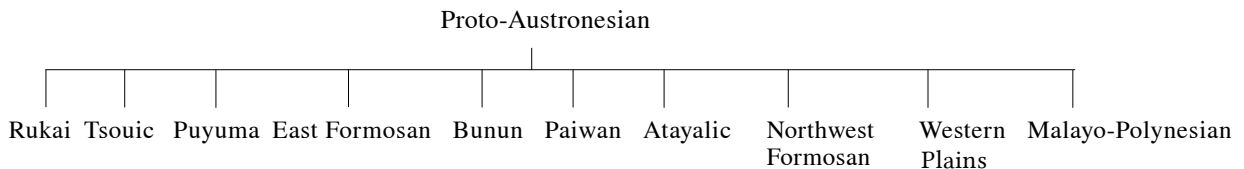

8.2 Implications

There are four important implications that can be drawn from the analysis I have presented in this dissertation.

First, Philippine-type languages do not employ a case system that is as typologically peculiar as previously thought. Under the conventional analysis that equates Pivot status with subjecthood, Philippine-type languages are typologically unique because seemingly non-core phrases such as Location, Instrument, and Benefactor are all eligible to serve as the subject of a clause. Under the present analysis, however, Philippine-type languages exhibit a typologically common accusative Case system that requires no special assumption in its Case-licensing mechanism, whereby Pivot status is independent of Case.

Second, the current analysis of the nature of Philippine-type voice morphology (Section 5.3) suggests that Philippine-type “voice” is fundamentally different from Indo-European “voice”. The former is *topic-indicating morphology*, whereas the latter is *valency-rearranging morphology*. From the perspective of Minimalist syntax (Chomsky 1995, 2000, 2001), the former is hosted at C, while the latter is hosted at or below Voice⁰.

Importantly, as Philippine-type “voice” is not associated with valency-rearranging operations, it has no direct interaction with the case system of a language. This suggests that “(Philippine-type) symmetrical voice” (e.g., Foley 1998, 2008; Himmelmann 2002; Riesberg 2014), which is often treated as a third type of alignment system alongside “nominative-accusative” and “ergative-absolutive”, is in fact fundamentally different from these in nature. In other words, both nominative-accusative languages and ergative-absolutive languages may employ topic-indicating morphology on the verb and exhibit what is conventionally called a “symmetrical voice” system. Therefore, the notion of “symmetrical voice” should be considered separately from case/alignment systems.

Third, the accusative analysis of Philippine-type languages presented in this study, and the fact that only the “Pivot”-marked phrases may undergo A'-extraction in Philippine-type languages, suggests that A'-extraction asymmetry in some languages can be independent of syntactic ergativity.

Finally, in the second part of this dissertation, I observed that the subgrouping results reached by diachronic proposals built on inaccurate assumptions about the synchronic syntax of Philippine-type languages are in conflict with various other types of evidence for subgrouping. This illustrates that any diachronic proposal should be built upon a solid understanding of the synchronic facts.

Appendix I: The locus of the Pivot and the word order variation among Philippine-type languages

In this appendix, I discuss two follow-up questions associated with the analysis of “Pivot”-marking and Philippine-type voice morphology:

- (1) a. If the internal topic (the Pivot) in Philippine-type languages must agree with the topic-probe, does the Agree relation trigger merger of the Pivot to [Spec CP]?
 b. Why do some Philippine-type languages require the Pivot to occupy the clause-final position, while others do not?

As introduced in Chapter 1, Philippine-type languages exhibit three major types of word order.¹ The first type requires the Pivot to appear in sentence-final position, regardless of its thematic role or grammatical relation (2a). The second type exhibits a word order pattern that follows the thematic hierarchy, whereby an Agent always precedes a Theme (and other peripheral phrases) in linear order, regardless of the voice type of the clause (2b). Languages of a third type exhibit flexible word order among nominals (2c):

- (2) *Three common types of word order for Philippine-type languages*
- a. *Pivot-final* (V- non-Pivots - Pivot), e.g., Malagasy, Seediq, Atayal, Tsou, Pazeh
 b. *Thematic hierarchy* (V - Agent - Theme - X), e.g., Amis, Tagalog
 c. *Flexible* (V - flexible), e.g., Puyuma, Paiwan

To the best of my knowledge, there is no clear evidence that any one of the three types of word order is prototypical of the Philippine-type voice system, as each of the three is attested within and across multiple Austronesian primary branches. Importantly, despite their differences in word order, all these languages share the same Philippine-type characteristics in terms of argument-marking, Pivot-selection mechanism, and A'-extraction restriction.

Under the current analysis, a Pivot in Philippine-type languages is under an A'-agree relation with the δ -probe at C, as in (3):



Given (92), if δ -agreement is accompanied by A'-movement of the goal to [Spec CP], a Pivot should occupy an A'-position. Alternatively, if this Agree relation does not trigger merger of the

¹ Here, I exclude Philippine-type languages with an SVO word order such as Saisiyat and West Coast Bajau, as SVO order is generally agreed to be a secondary innovation affected by language contact or independent change (Blust 2013).

Pivot to [Spec CP], a Pivot would appear *in situ*. In this subsection, I argue for the analysis in (4) for the variation in word order found among Philippine-type languages:

- (4) The “Pivot-final” word order (91a) is a result of merger of the topic to [Spec CP] driven by δ -agreement. In languages that do not exhibit a Pivot-final word order, the Pivot undergoes covert movement to [Spec CP] at the LF.

Following previous analyses by Pearson (2001) and Aldridge (2004), I assume that the Pivot-final word order (2a) is derived from A'-movement of the Pivot to [Spec CP], followed by predicate-fronting. Given the focus of this study, I do not go into the specific derivation of this line of analysis in detail.

In what follows, I discuss evidence for the proposal in (4).

(I) Theoretical assumptions

For the sake of clarity, I will use the theory-neutral term “*promotion-to-Pivot*” in the following discussion to refer to the mechanism that places a phrase in Pivot status. If our current proposal is on the right track, “*promotion-to-Pivot*” refers to an A'-agree relation established between a topic-probe (i.e., δ -probe) and the internal topic of a clause.

The goals of the following subsection are two-fold. The first is to show that “*promotion-to-Pivot*” shows typical A'-properties but not A-properties—which follows from the current proposal. The second is to show that Philippine-type languages with all three types of word order show evidence of (covert) A'-movement of the Pivot.

It is standardly assumed that there is a distinction between unbound dependencies such as *wh*-movement and more local dependencies such as passivization and raising. The former are conventionally referred to as A'-movements and the latter as A-movement. In approaching the nature of *promotion-to-Pivot* in Philippine-type languages, I will follow the standard assumptions below about A- and A'-characteristics (van Urk 2015):

(5) *Typical traits of A- and A'-operations*

<i>(i) A-properties</i>	<i>(ii) A'-properties</i>
a. No reconstruction for Principle C	Reconstruction for Principle C
b. New antecedents for anaphors	No new antecedents for anaphors
c. No Weak Crossover	Weak Crossover (& Weakest Crossover)
d. Restricted to nominals	Not restricted to nominals

Following recent proposals (Obata 2010; Obata & Epstein 2011; Miyagawa 2010, 2017; van Urk 2015), I further assume that A- and A'-properties derive from *properties of the attracting feature*, rather than the functional head that hosts the phrase that undergoes merger. Under this assumption,

- e. b<in>unu' nog libun koyon og lawas=non. [Subanon]
 <PV.PRF>kill X girl DET PIVOT self=3SG.POSS
 'The girl killed *herself*.'
- f. hajain-dRajaona ny tenany. [Malagasy]
 PV.respect-Rajaona DET 3.REFL
 'Rajaona respects *himself*.' (Pearson 2001:102; glosses mine)

Consistent with the observations above, across Puyuma, Amis, Seediq, Tagalog, and Malagasy, a quantifier external argument can bind into a pronominal Theme that bears Pivot status, suggesting that promotion-to-Pivot shows reconstruction effects or stays *in situ* (8):

(8) *Promotion-to-Pivot shows reconstruction effects in quantifier-variable binding*

- a. tu=pukpuk-aw kana taynaynayan driya tu=walak. [Puyuma]
 3.X=hit-PV DF.X mothers every 3.POSS.PIVOT=child
 'Every mother<i> hit her<i> child.'
- b. ma-palu nu cimacima a ina ku wawa nangra. [Amis]
 PV-hit X every LK mother PIVOT child 3PL.POSS
 'Every mother<i> hit her<i> child.'
- c. gulu-un liyun na knkingal bubu ka laqi=daha. [Seediq]
 love-PV very X every mother PIVOT child=3PL.POSS
 'Every mother<i> loves her<i> child.'
- d. m<in>amahal ng kangyang ama ang baway anak. [Tagalog]
 <PV.PRF>love X 3SG.POSS father PIVOT every child
 'Every child<i> loves her<i> father.' (Rackowski 2002:42)
- e. novangian' ng mpianatra tsirairay ny rainy omaly. [Malagasy]
 PV.PRF.visit DET student each DET father-3 yesterday
 'Each student<i> visited his<i> father yesterday.' (Pearson 2005:424)

b. *No new antecedent for anaphors*

Second, A-movements are known to rearrange the binding relations by creating a new antecedent for anaphors, exemplified with the following English sentences:

(9) *New antecedent in English A-movement*

- a. John seems to himself [_i to be smart].
 b. *Mary_i, herself_i believed that John had a crush on _____i.

Consistent with its showing reconstruction effects or never undergoing movement, Promotion-to-Pivot across Puyuma, Amis, Seediq, and Tagalog does not create a new antecedent for anaphors, as seen in (10):

(10) *No new antecedent for anaphor: Philippine-type PV clauses*

- a. *tu=tusuk-aw kanta'aw i pilay. [Puyuma]
3.X=stab-PV 3SG.X.SELF SG.PIVOT Pilay
(intended: 'Herself gave *Pilay* an injection.')
- b. *ma-palu nira tu ci kulas. [Amis]
PV-beat 3SG.X REFL PN.PIVOT Kulas
(intended: 'Himself beat *Kulas*.')
- c. *s<n>pi na heya nanaq ka watan. [Seediq]
dream<PRF.PV> X 3SG REFL PIVOT Watan
(intended: 'Himself dreamt of *Watan*.')
- d. *sa-sampal-in ng kanyang sarili si juan. [Tagalog]
CONT-slap-PV ID.X 3SG REFL PN.PIVOT Juan
(intended: 'Himself will slapp *Juan*.')

c. *Weak Crossover effect*

Third, consistent with the preceding observations, promotion-to-Pivot across Puyuma, Amis, and Seediq shows *Weak Crossover effects* (Postal 1971; Lasnik & Stowell 1991), a typical A'-property:

(11) *Weak Crossover effects*

A pronoun may be interpreted as a variable bound by a quantifier phrase QP iff (the case position of) the QP c-commands (the case position of) the pronoun, namely:

*Op_i . . pro_i . . . <t_i>

As is well-known, A-movement of a quantified phrase differs from A'-movement with regard to whether a Weak Crossover effect is triggered (see, e.g., Postal 1971; Wasow 1972; Lasnik & Stowell 1991; Postal 1993): an A-movement can obviate the Weak Crossover effect, whereas an A'-movement cannot. This is seen in the following English examples (12a)-(b):

(12) *Weak Crossover effects*

It seems to her_i fans that every actress*_i is the prettiest.

- a. Every actress_i seems to her_i fans [___ to be the prettiest]. [A-movement]
b. Who_i did her*_i fans think is the prettiest ____? [A'-movement]

Given (12), if promotion-to-Pivot is an A-operation, we expect it to obviate the Weak Crossover effects, as in (12a). If it is an A'-operation, as I argue to be the case, promoting a quantifier phrase to the Pivot status is predicted to not obviate the Weak Crossover effect.

The latter prediction is borne out with observations from Puyuma, Amis, and Seediq, as well as some data collected from Tagalog. As seen in (13a)-(d), promotion-to-Pivot does not obviate the Weak Crossover effect, suggesting that it diverges from promotion-to-subject operations.

(13) *Weak crossover effects in promotion-to-Pivot operations*

- a. ku=pubibi'-ay [kantu=dawa] [tu=uma' kana maydrangan driya]. [Puyuma]
 1SG.X=sow-LV [3.POSS.Y=millet] [3.PIVOT.POSS=field LK old.persons every]
 'I sowed his/her<i> millet at every old person's<j/?i> field.'
- b. sa-pi-tangtang aku [tu titi nangra] [ku siwuy a cimacima a ina]. [Amis]
 CV-PI-cook 3SG.X [Y pork 3PL.POSS][PIVOT pot LK every LK mother]
 'I cooked her<i> pork with every mother's<j/?i> pot.'
- c. s-beebu=mu [Ø laqi=daha] [ka qreti knkingal riso]. [Seediq]
 CV-beat=1SG.X [Y child=3PL.POSS] [PIVOT stick every young.man]
 'I beat his child<i> with every young man's<j/*i> stick.'
- d. i-p<in>ag-luto=ko [ang bawat bata] [ng kanilang isda]. [Tagalog]
 CV-PAG-cook=1SG.X [PIVOT every child][ID.Y 3PL.POSS.Y fish]
 'I cooked their<i> fish for every child<j/?i>.'

It is noteworthy, however, that parallel sentences of (13) in Malagasy, Tagalog, and Seediq behave differently from the examples above. This phenomenon will be discussed below.

(III) Weakest Crossover effects in Malagasy, Tagalog, and Seediq promotion-to-Pivot operations

We have seen in the discussion above some diagnostics that suggest that the promotion-to-Pivot operations across Puyuma, Amis, Seediq, and Tagalog show no A-properties. This observation follows from our proposal that Pivots in Philippine-type languages either undergo A'-movement or stay *in situ*.

For languages that exhibit a Pivot-final word order, such as Malagasy and Seediq, the Pivots have been commonly assumed to undergo A'-movement to [Spec CP] (Pearson 2001, 2005; Aldridge 2004). A remaining question here, however, is whether topic-agreement in languages that do not exhibit a Pivot-final word order triggers no A'-movement of the Pivot. In the following discussion, I put forward the proposal that the Pivot in all three types of Philippine-type languages in fact undergoes A'-movement to [Spec CP]—however, this movement is covert in languages that do not exhibit a Pivot-final word order.

Pearson (2001, 2005) reports that promotion-to-Pivot operations in Malagasy show reconstruction effects.² At the same time, however, the language shows a perplexing phenomenon whereby promoting a *quantifier Theme to Pivot status* allows it to bind into a pronominal external argument. As seen in (14)-(15), when a quantifier Theme is in Pivot status, it can bind into a pronominal external argument, with different degrees of acceptability among similar sentences:

(14) *A change in binding relation triggered by promotion-to-Pivot: Malagasy*

- a. *namangy ny mpianatra tsirairay ny rainy omaly. [AV]
 PST.AV.visitDET student each DET father-3 yesterday
 'His<i> father visited each student<*> yesterday.'
- b. %namangy ny rainy ny mpianatra tsirairay omaly. [PV]
 PST.PV.visit DET father-3 DET student each yesterday
 'His<i> father visited each student<%i> yesterday.' (Pearson 2005:427)

(15) *A change in binding relation triggered by promotion-to-Pivot: Malagasy*

- a. *nanoroka ny vehivavy rehetra ny vadiny. [AV]
 PST.AV.kiss DET woman all DET spouse-3
 'Their<i> spouse(s) kissed all the women<*>.'
- b. norohan' ny vadiny ny vehivavy rehetra. [PV]
 PST.PV.kiss DET spouse-3 DET student all
 'Their spouse(s)<i> kissed all the women<i>.' (Pearson 2005:427)

Pearson argues that this phenomenon is best analyzed as a manifestation of the *Weakest Crossover effect* (Lasnik & Stowell 1991; Ruys 2004), whereby A'-moving a quantifier phrase may obviate Weak Crossover effects. See the following examples from English (17a)-(c):

(16) *Weakest Crossover*

In a configuration where a pronoun P and a trace T are both A'-bound by a category C, T must c-command P. (Lasnik & Stowell 1991:691)

(17) *Weakest Crossover effect in English*

- a. Who_i will be easy for us [to get [his mother] to talk to e_i]?

² As seen below, in Malagasy PV clauses, a pronominal Pivot can be interpreted as a variable bound by a quantifier external argument, suggesting that the Pivot is interpreted at its theta-position (14a). Therefore, in such sentences, voice alternation between AV and PV does not affect the interpretation of the sentences, given the manifestation of reconstruction effects:

- a. namangy ny rainy ny mpianatra tsirairay omaly. [AV]
 PST.AV.visit DET father-3 DET student each yesterday
 'Each student<i> visited his<i> father yesterday.'
- b. novangian' ny mpianatra tsirairay ny rainy omaly. [PV]
 PST.PV.visit DET student each DET father-3 yesterday
 'Each student<i> visited his<i> father yesterday.' (Pearson 2005:424)

- b. This book_i, I expect [its author] to buy e_i].
- c. Gerald_i, who his_i mother loves, is a nice guy. (Lasnik & Stowell 1991)

Similar phenomena are observed in topic constructions in German and Icelandic. As Richards (2000) and Pearson (2001, 2005) report, in both languages, A'-topics are able to bind pronouns from their surface position, even when the trace of the topic does not c-command the pronoun (18)-(19):

(18) *Weakest Crossover effects in German topic constructions*

- a. Sein Vater hat gestern jeden Studenten besucht.
his.nom father has yesterday every.acc student.acc visited
'His<i> father visited every student<*> yesterday.'
- b. Jeden Studenten hat gestern sein Vater besucht.
every.acc student.acc has yesterday has.nom father visited
'Every student<i>, his<i> father visited yesterday.' (Pearson 2005:426)

(19) *Weakest Crossover effects in Icelandic topic constructions*

- a. Foreldrar hans kenna sérhverjum stráki að keyra.
parents his teach every.acc boy.acc to drive
'His<i> parents teach every boy<*> how to drive.'
- b. Sérhverjum stráki kenna foreldrar hansí að keyra.
every.acc boy.acc teach parents his to drive
'Every boy<i>, his<i> parents teach how to drive.' (Richards 2000)

Given the observations above from German and Icelandic A'-constructions, Pearson (2001) concludes that while the presence of Weak Crossover is a reliable diagnostic for A'-movement, its absence cannot be taken as evidence for A-movement, as A'-movement constructions in different languages have been observed with Weakest Crossover effects.

Interestingly, a number of examples collected from Seediq and Tagalog share the same effects—although only Seediq and not Tagalog shares a Pivot-final word order with Malagasy. In both languages, a Pivot-marked quantifier Theme may bind into a pronominal external argument in some circumstances:

(20) *Weakest Crossover effects in Seediq promotion-to-Pivot operations*

- a. se<n>la'u na dangi=daha ka knkingal dunux weewa. [PV]
comb<PRF.PV> X friend=3PL.POSS PIVOT every head young.lady
'Their<i> boyfriend(s) combed every young lady's<i> hair.'
- b. wada=mu s-paadis [Ø bubu=daha ka [patis na knkingal laqi muuyas]. [CV]
PRF=1SG.X CV-mail [Y mother=3PL.POSS] PIVOT [book POSS every student]
'I mailed their<i> mother every student's<i> book.'

(21) *Weakest Crossover effects in Tagalog promotion-to-Pivot operations*

- a. i-p<in>ang-luto=ko [ang palayok ng bawat nanay] [ng kanilang isda]. [PV]
CV-<PRF>PANG-cook=1SG.X [PIVOTpot LK every mother] [Y 3PL.POSS fish]
'I cooked their<i> fish with every mothers'<i/j> pot.'
- b. i-p<in>ang-kain=ko [ang kutsara ng bawat bata] [ng kanilang pizza]. [PV]
CV-<PRF>PANG-eat=1SG.X [PIVOTspoon LK every child] [Y 3PL.POSS pizza]
'I ate their<i> pizza with every child'<i/j> spoon.'

A similar observation was made in Rackowski (2002) on Tagalog, who reports that a pronominal external argument may be interpreted as a variable of a Pivot-marked quantifier Theme (22a)-(b):

(22) *Promotion-to-Pivot obviates Weak Crossover: Tagalog*

- a. nag-mamahal ang kanyang ama ng bawat anak. [AV]
AV.PRF-love PIVOT 3SG.POSS father ID.Y every child
'Her<i> father loves every<*i> child.'
- b. m<in>mahal ng kanyang ama ang bawat anak. [PV]
<PV.PRF>-love DF.X 3SG.POSS father PIVOT every child
'Her<i> father loves every<i> child.' (Rackowski 2002:36)

I remain agnostic about the nature of these Weakest Crossover-like effects in these three Philippine-type languages. What is important here is that the same effect is observed both in Philippine-type languages with a Pivot-final word order (Malagasy, Seediq), as well as those with other types of word order, in which the Pivot appears to stay *in situ* (Tagalog, Amis, Puyuma). Given the presence of this effect in both types of languages, I tentatively propose that topic-agreement (δ -agreement) triggers A'-movement in all Philippine-type languages—and that the movement is covert in languages that do not show a Pivot-final word order.³

³ See a similar proposal for Tagalog in Richards (2000).

Appendix II: The “Pivot-only” constraint revisited

In this appendix, I revisit the Philippine-type “Pivot-only” constraint in A'-extraction (23), and discuss how this phenomenon can be captured under the analysis of Philippine-type voice morphology presented in Section 5.3.

(23) *The “Pivot-only” constraint in A'-extraction: Seediq*

- a. ima ka [s<m><n>eeliq/*-un/*-an/*s- Ø rodux]? [Extraction of the external argument]
 who PIVOT [<AV><PRF>butcher/*PV/*LV/*CV Y chicken]
 ‘Who is the one that butchered the/a chicken?’
- b. maanu ka [s-seeliq-un/*<m>/*-an/*s- na robo]? [Extraction of the internal argument]
 what PIVOT [RED-butcher-PV/*AV/*LV/*CV X Robo]
 ‘What is thing that Robo butchered?’
- c. inu ka [s<n>eeliq-an/*<m>/*-un/*s- na robo Ø rodux]? [Extraction of location]
 where PIVOT [butcher<PRF>-LV/*AV/*PV/*CV X Robo Y chicken]
 ‘Where did Robo butcher the/a chicken?’
- c. ima ka [s-seeliq/*<m>/*-un/*-an na robo Ø rodux]? [Extraction of benefactor]
 who PIVOT [CV-butcher/*AV/*PV/*LV X Robo Y chicken]
 ‘Who did Robo butcher the/a chicken for?’

As exemplified above, in Philippine-type languages, the verbal morphology in clauses that involve A'-extraction must indicate the extracted phrase as the Pivot. Therefore, in sentences with external argument extraction, an “AV”-verb is obligatory used (24a); in transitive sentences with internal argument extraction, “PV” is the only acceptable voice-marking (24b); in sentences with extraction of a locative or benefactive phrase, the verbal morphology must be in “LV” and “CV”, respectively (23c)-(d).

While various proposals have analyzed this morphological constraint as an *extraction restriction*, I put forward the proposal in (24):

(24) The “Pivot-only” constraint is in fact not an *extraction restriction*, but the spell-out of different bundles of Agree relations with a relativized phrase, analogous to that with the topic in clauses with no A'-extraction.

In approaching this proposal, I first point out that *relativization* is the only A'-operation in prototypical Philippine-type languages. I then propose the analysis in (25), following similar proposals for Kilega (Miyagawa 2010, 2017) and Dinka (van Urk 2015):

- (25) In Philippine-type languages, *relativization* and *topicalization* are driven by a flat A'-probe (i.e., uδ). This probe can target phrases that bear either a [Top] or a [Rel] feature.

Under this proposal, A'-extraction in Philippine-type languages is unrestricted, as phrases ranging from subjects to adjuncts can all undergo A'-extraction via the gap strategy. Under this analysis, then, Philippine-type Austronesian languages are fundamentally different from syntactically ergative languages.

In the following discussion, I first clarify the nature of A'-extraction in Philippine-type languages. I then outline my account of the "Pivot-only" constraint.

I. *Relativization is the only A'-operation in prototypical Philippine-type languages*

There has been consensus in the literature that Philippine-type languages are *wh-in-situ* languages (Potsdam 2006; Potsdam 2009; Lin 2013; Aldridge 2004; 2017). This is exemplified with the Puyuma data below, where a *wh*-phrase can either stay *in situ* or be introduced in a pseudo cleft:

(26) *Wh-questions in Seediq*

- a. s<m><n>eeliq Ø **maanu** ka robo? [Wh-in-situ]
butcher<AV><PRF> **Y what** PIVOT Robo
'What did Robo butcher?'
- b. **maanu** ka [s-seeliq-un na robo]? [pseudo clefting]
what PIVOT [RED-butcher-PV X Robo]
'What is the thing that Robo will butcher?'

Following the standard analysis (e.g., Potsdam 2006; Kroeger 2009; Lin 2013; Aldridge 2014), I assume that the presupposed clause of pseudo clefts has the structure of a headless relative clause. Under this analysis, the presupposed clause in (26b), i.e., *s-seeliq-un na Robo* 'the thing that Robo will butcher', shares structure with the following relative clauses (27a) and (27b):

(27) *The presupposed clause of pseudo-clefts as a headless relative clause*

- a. maanu ka [s-seeliq-un na dakis?] [pseudo-cleft]
what PIVOT [IRR-butcher-PV X Dakis]
'What is the thing that Dakis will butcher?'
- b. rodux [(ka) s-seeliq-un na dakis] [relative clause]
chicken [(LK) IRR-butcher-PV X Dakis]
'the chicken that Dakis will butcher'

As relative clauses and pseudo clefts are standardly considered to be the only two A'-operations in Philippine-type languages, I assume that all instances of A'-extraction in a prototypical Philippine-type voice system are *relativization* in nature.

The assumption that relativization involves A'-extraction in these languages is supported by the following data from Puyuma, Amis, Seediq, and Tagalog, which shows that relativization is sensitive to island conditions. As seen below, extracting a phrase out of a complex NP island results in ungrammaticality (28a)-(d):⁴

(28) *Island sensitivity in relativization: complex NP island*

- a. *imanay (na) nu=k<in>aladram-an [na ngay [na m<in>atray]]? [Puyuma]
 who (PIVOT) 2SG.X=know<PRF>-LV [DF.PIVOT rumor [LK die<PRF>AV]]
 (intended: 'Who did you know about the rumor that passed away?')
- b. *cima ku ka-fana'-an isu [(ku) califacif [(a) ma-patay]]? [Amis]
 who PIVOT know-LV[PV] 2SG.X [(PIVOT) rumor [(LK) AV-die]]
 (intended: 'Who did you know about the rumor that passed away?')
- c. *ima ka kela-un=su [ka sinbu [(ka) m<n>huqil]]? [Seediq]
 who PIVOT know-PV=2SG.X [PIVOT news [(PIVOT) AV<PRF>die]]
 (intended: 'Who did you know about the news that passed away?')
- d. *sino ang na-balita-an=mo [ang balita [na na-matay]]? [Tagalog]
 who PIVOT PRF-hear-LV[PV]=2SG.X [PIVOT rumor [LK AV.PRF-die]]
 (intended: 'Who did you hear about the rumor that passed away?')

Having clarified the nature of A'-extraction in these languages, I review previous accounts for the "Pivot-only" constraint in relative clauses and outline my proposal.

III. *Previous accounts of the "Pivot-only" constraint*

Much previous work has analyzed the "Pivot-only" constraint as an *extraction restriction* (e.g., Payne 1982; Guilfoyle, Hung, & Travis 1992; Mithun 1994; Aldridge 2004, 2017; Rackowski & Richards). Under a family of ergative analyses of Philippine-type languages, this phenomenon manifests an "absolutive-only" restriction, accordingly to which the "Pivot-only" constraint is a hallmark of syntactic ergativity.

Rackowski & Richards (2005), however, attribute the nature of this constraint to (29):

- (29) Only those CPs and DPs that Agree with a phase head on independent grounds (e.g., direct objects and complement clauses) are transparent for *wh*-extraction.
 (Rackowski & Richards 2005:582)

Under (30), the difference in A'-extraction accessibility between clauses of different voice types relies crucially on (i) the purported presence or absence of an EPP feature on *v* (Voice⁰ under the present framework) and (ii) the purported presence or absence of a high applicative phrase that

⁴ According to primary data, relative clauses in all four languages are sensitive to adjunct islands as well.

introduces an applied object at the highest internal argument position in a clause. This analysis shares a core assumption with ergative approaches to this extraction constraint in assuming that only the structurally highest argument at [Spec VoiceP] can undergo A'-extraction (i.e., “Attract Closest”).

Pearson (2001, 2005), however, argues that the “Pivot-only” constraint is a product of *wh*-extraction feeding topicalization (i.e., “promotion-to-Pivot”). Under his analysis, the “Pivot-only” constraint derives from competition between the promotion-to-Pivot operation (topicalization) and *wh*-extraction for the same landing site, i.e., [Spec WhP]. This proposal is illustrated below in (30). In Pearson’s system, [Spec WhP] is an A'-position that must be filled. Therefore, in clauses with no relativization, a *wh*-operator will raise to this position to satisfy this requirement, and be coindexed with a base-generated topic at [Spec TopP]. Under this analysis, voice morphology is the spell-out of the functional head that Case-licenses the *wh*-operator. In instances of relativization, a *Rel*-operator will raise to fill in the same position, [Spec WhP]. Therefore, this extraction blocks topicalization (i.e., the promotion-to-Pivot operation), which will otherwise take place. As a result, relativization feeds topicalization, with the Case-licensing head of the *wh*-extracted (relativized) phrase spelled out as voice morphology. This gives rise to the apparent morphological constraint of “Pivot-only” in relative clauses.

(30) *The nature of the “Pivot-only” constraint under Pearson (2001, 2005)*

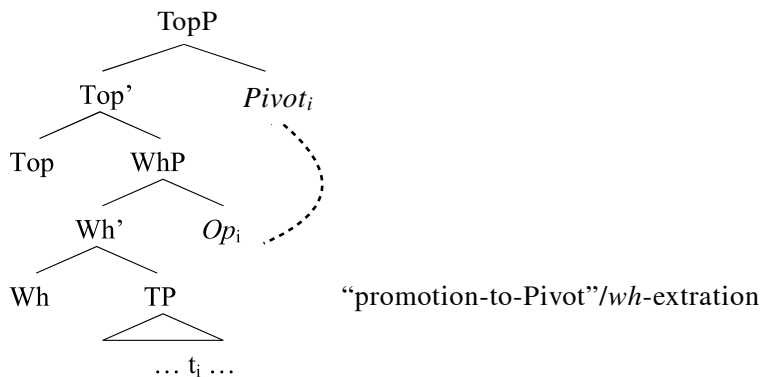

Given the conclusion of Section 5.3 that the analysis of Philippine-type voice affixes under all three proposals is incompatible with the selectional mechanism of the Pivot in several types of basic constructions, the nature of the “Pivot-only” constraint requires a reconsideration.⁵

⁵ As concluded in Chapters 3–4, Puyuma, Amis, Seediq, and Tagalog all lack evidence for (i) an EPP feature on Voice in non-AV clauses and (ii) an applicativizing operation in LV/CV clauses). This conclusion suggests that the first two approaches (Aldridge 2004 et seq.; Rackowski & Richards 2005) are difficult to maintain. As discussed in Section 5.3.2, Pearson’s analysis, which assumes voice morphology to be the spell-out of functional heads, also faces a number of empirical challenges.

III. Proposal: “Pivot-only” is not an extraction constraint, but the spell-out of δ -agreement

I argue that the phenomenon of “Pivot-only” can receive a simple account if this apparent morphological constraint is analyzed as the spell-out of Agree relations that target the relativized phrase, analogous to that with the topic phrase in clauses with no relativization.

In other words, I propose that in relative clauses, the different bundles of Agree relations established with the phrase that bears a [Rel]-feature are spelled-out as voice morphology. Namely, the relativized phrase is the goal of δ -agreement in relative clauses. This analysis is built on the proposal in (31):

- (31) Topicalization and relativization in Philippine-type languages are not driven by two distinct A'-probes, but by the same A'-probe (i.e., [u δ]) on C.

Under this proposal, in clauses with A'-extraction, the δ -probe agrees with a phrase that bears a [Top]-feature (32a), whereas in instances of relativization, the δ -probe targets the phrase that bears a [Rel]-feature (32b). In both cases, the Agree relations that agree with the goal of δ -probe are spelled out as voice morphology and give rise to the apparent morphological restriction of “Pivot-only”.

- (32) Proposal: [u δ] as a composite probe for Top and Rel

a. Non-RCs

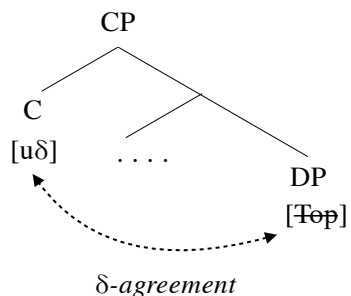

b. Relative clauses

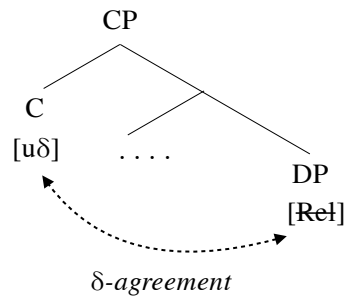

The current proposal follows from an observation first discussed in Kuno (1973), that relativization and topicalization in many languages cannot cooccur in the same clause (e.g., Kuno 1973; Gundel 1974, Chomsky 1977; Bak 1984; Miyagawa to appear). For instance, in English and Korean, topicalization cannot appear in a relative clause, as in (33)-(34). This observation has led to such claims as (i) relative clauses in English are essentially a topic-comment structure (Gundel 1974) and (ii) relativization in Japanese is an instance of topicalization (Kuno 1973):

- (33) Relativization and topicalization are incompatible within a single clause: English

- a. *This is the boy_i [whom *the book*_j, John gave away ____j to ____i].
 b. *The man_i [who *that book*_j, ____i wrote ____j] is a well-known linguist

- c. *I love Mary_i [who *the dog*_j, _____i was running after _____j]

(34) *Relativization and topicalization are incompatible within a single clause: Korean*

*ku [totwuk-**un** caphi-n] swunkyeung-i sang-ul patassta.
 the [thief-**TOP** was-caught] policeman-NOM prize-ACC received
 (The policeman whom *the thief*, he was caught by was awarded.’ (Bak 1984:163)

Given the crosslinguistically observed incompatibility of relativization and topicalization, I adopt the following proposal from van Urk (2015) and Miyagawa (2010, 2017) for Philippine-type languages:

- (35) Types of A'-feature, such as [Top], [Rel], and [Foc], may be driven by a single “catch-all” A'-probe, as opposed to those in other languages, which employ separate probes for [Top], [Rel], and [Foc].

In light of van Urk’s analysis for Dinka, I propose that a probe may be flat and be satisfied by any bundle of features regardless of value (see also similar proposals in Nevins 2007; Preminger 2011; Coon & Bale 2014). Specifically, I propose that in Philippine-type languages, an A'-probe may be also satisfied equally by [Top] and [Rel], assuming that these languages pattern with English, Japanese, and Korean in disallowing the cooccurrence of both operations in a single clause.

Similar to Philippine-type languages, Dinka exhibits a three-way voice system with articulated verbal morphology (*Subject voice* vs. *Object voice* vs. *Oblique voice*) that indicates the grammatical relations of the topic phrase. Crucially, relativization in Dinka triggers the same obligatory verbal morphology that indicates the relativized phrase as the “topic” of the clause, manifesting a constraint similar to “Pivot-only”. See the examples in (36)-(37):

(36) *Topicalization in Dinka*

- | | | |
|----|---|-----------------|
| a. | Àyén à-càm cuḷin nè pǎal.
Ayen 3S-eat.SV food P knife
‘Ayen is eating food with a knife.’ | [Subject voice] |
| b. | cuḷin à-céem Àyén nè pǎal.
food 3S-eat.OV Ayen.GEN P knife
‘Food, Ayen is eating with a knife.’ | [Object voice] |
| c. | pǎal à-céemè Àyén cuḷin.
knife 3S-eat.OBLV Ayen.GEN food
‘With a knife, Ayen is eating food.’ (van Urk 2015:61) | [Oblique voice] |

(37) *Extraction restriction in Dinka relative clauses*

- | | | |
|----|---|----------------------|
| a. | móny [CP càm/*céem/*céemè cuḷin nè pǎal].
man [CP eat.SV/*eat.OV/*eat.OBLV food P knife]
‘ <i>the man</i> who is eating food with a knife’ | [Subject extraction] |
|----|---|----------------------|

- b. **cuḷin** [CP ć́em/*c̀am/*ć́em̀̀ m̀c ǹ p̀al]. [Object extraction]
food [CP **eat.OV**/***eat.SV**/***eat.OBLV** man.GEN P knife]
 ‘*the food* that the man is eating with a knife’
- c. **p̀al** [CP ć́em̀̀/*c̀am/*ć́em m̀c cuḷin]. [Oblique extraction]
knife [CP **eat.OBLV**/***eat.SV**/***eat.OV** man.GEN food]
 ‘*the knife* that the man is eating food with’ (van Urk 2015:66)

In the spirit of van Urk’s account of the “Pivot-only” constraint in Dinka, I propose that the shared morphological constraint in relativization and topicalization in Philippine-type languages derives from their being driven by the same A’-probe. If this proposal is on the right track, Philippine-type languages impose few constraints in A’-extraction, which allows adjuncts to be extracted via the gap strategy. I leave the details of this proposal for future investigation.

Appendix III: The nature of Austronesian “nominalizer/voice affix” homophony

In this appendix, I revisit the phenomenon of “nominalizer/voice affix homophony” found in many Philippine-type languages, and discuss how it can be straightforwardly accounted for under the current analysis of Philippine-type voice affixes.

Nominalizer-voice affix homophony refers to a phenomenon commonly observed in Philippine-type languages, in which a voice affix used in indicative sentences ((39a), (40a)) shares the same form with the affixal morphology present in their corresponding relative clauses ((39b)-(d), (40b)-(c)). The affixal morphology present in relative clauses is conventionally called “nominalizer” (see, e.g., Starosta, Pawley & Reid 1981; Ross 2009, 2012; Kaufman 2009, 2017; Aldridge 2016a). In the descriptive literature, this term is also commonly used to refer to Philippine-type voice morphology present in (i) the presupposed clause of a pseudo cleft and (ii) nominals that involve participant nominalization. See the following data from Seediq and Tagalog:

(38) *Nominalizer-voice affix homophony in Seediq*

- a. puq-**un** na dakis ka rodux. [Patient voice affix *-un*]
 eat-**PV** X Dakis PIVOT chicken
 ‘Dakis will eat the chicken.’
- b. puq-**un** (/na dakis) [“Patient nominalizer” *-un*]
 eat-“**PT.NMZ**” (/X Dakis)
 ‘thing eaten (/thing that Dakis ate)’
- c. [_{DP} rodux/∅ [_{CP} Op_i [uq-**un** na dakis <t_i>]] [“Patient nominalizer” *-un*]
 [_{DP} chicken/∅ [_{CP} Op_i eat-“**PT.NMZ**” X Dakis <t_i>]]
 ‘the chicken/the thing that Dakis will eat’ [N, RC]

(39) *Nominalizer-voice affix homophony in Tagalog*

- a. bi-bilih-**in** ni ivan ang kendi. [Patient voice affix *-in*]
 CONT-buy-**PV** PN.X Ivan PIVOT candy
 ‘Ivan will buy the candy.’
- b. bilih-**in** (/ni ivan) [“Patient nominalizer” *-in*]
 buy-“**PV.NMZ**” (/X Ivan)
 ‘thing bought (/thing that Ivan bought)’
- c. [_{DP} kendi/∅ [_{CP} Op_i bi-bilih-**in** ni ivan <t_i>]] [“Patient nominalizer” *-in*]
 [_{DP} candy/∅ [_{CP} Op_i CONT-buy-“**PV.NMZ**” PN.X Ivan <t_i>]]
 ‘the chicken/the thing that Ivan will eat’ [N, RC]

The apparent homophony between “voice affixes” and “nominalizers” has motivated several diachronic analyses, including a well-known claim originated in Starosta, Pawley, & Reid (1981) called *Nominalization-into-verb*:

(40) The synchronic homophony between voice affixes and their functionally corresponding nominalizers is derived from an archaic reanalysis “nominalization-into-verb”. This morpho-syntactic change reanalyzed what were previously patient nominalizer, locative nominalizer, and instrumental nominalizer into the synchronic PV, LV, and CV affixes, respectively.

I argue that the proposal in (41) is unmotivated given the current analysis that Philippine-type voice morphology is *agreement-morphology* hosted at C. Given the consensus among the standard analyses that relative clauses in Philippine-type languages are fully finite (Paul 1999; Potsdam 2006; Pearson 2005; Aldridge 2004, 2014; Lin 2014), I argue that this “homophony” is only apparent, since what have conventionally been called “voice affixes” and “nominalizers” are essentially the same morphemes—both realize the spell-out of the same Agree relation(s) within finite CPs.⁶ This analysis is illustrated in (42)-(43):

(41) *The nature of “nominalizers” in Philippine-type languages*

When a CP is embedded under a D-shell, the morphological reflex of the Agree relation is conventionally called “nominalizer”.

(42) *The nature of “Voice affix”*

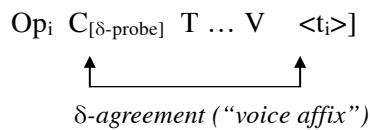

(43) *Proposal: the nature of “nominalizer”: Voice affix in CP-level nominalization*

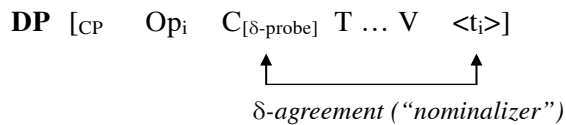

The implication of this analysis will be discussed in Chapters 6 and 7.

⁶ The finite CP analysis of relative clauses in Philippine-type languages is supported by the fact that relative clauses in Philippine-type languages show no evidence of a deficient size. To the best of my knowledge, these constructions are fully compatible with (i) a four-way voice alternation, (ii) aspect morphology, and (iii) mood inflection, as are clauses with no relativization.

Appendix IV: The prototypical argument-marking pattern of Philippine-type languages

Prototypical Philippine-type languages exhibit a four-way argument-marking system (Reid 1979; Ross 2006; Blust 2015), illustrated in (1). For the purpose of this dissertation, I replace the conventional labels “Nominative”, “Genitive”, and “Oblique” with “Pivot”, “X”, and “Y”, respectively. See Chapter 1 for a summary of my analysis of these markers. The parentheses in (1) indicate that the presence of the corresponding phrase is optional.

(1) TABLE 9.1. *The prototypical argument-marking pattern in Philippine-type languages*

	Actor voice	Patient voice	Locative voice	Circumstantial voice
External argument	Pivot	X	X	X
Internal argument	(Y)	Pivot	(Y)	(Y)
Location	(Loc)	(Loc)	Pivot	(Loc)
Instrument/benefactor	(Y)	(Y)	(Y)	Pivot

The marker of non-Pivot Instrument/Benefactive phrases deserves a note.¹ In many Philippine languages, non-Pivot Instrument or Benefactive phrases are marked with a specific set of prepositions (e.g., Tagalog *para* for Benefactive phrases and *tungkol* for Referential phrases). However, the presence of an (overt) preposition for such types of phrases seems to be an innovation below Proto-

¹ See, for example, the Paiwan data below, where the non-Pivot internal argument share Y-marking with the non-Pivot Instrument:

- a. q<m>alup a caucau **tua vavuy** i gadu **tua vuluq.** [Paiwan]
 <AV>hunt PIVOT man Y pig LOC mountain Y spear
 ‘The man hunts wild pigs in the mountains with a spear.’
- b. qalup-**en** nua caucau a vavuy i gadu **tua vuluq.**
 hunt-PV X man PIVOT pig LOC mountain Y spear
 ‘The man hunts *wild pigs* in the mountains with a spear.’
- c. qalup-**an** nua caucau **tua vavuy** a gadu **tua vuluq.**
 hunt-LV X man Y pig PIVOT mountain Y spear
 ‘The man hunts wild pigs *in the mountains* with a spear.’

Interestingly, in Tagalog, a Y-marking is still present between the innovative preposition (e.g., *para*) and the Instrument/Benefactive phrases:

- a. **nang-gamot** si ivan **kay viktor**ia sa klinika **para kay amber.** [Tagalog]
 AV-treat PN.IVOT Ivan PN.Y Victoria DF.Y clinic P PN.Y Amber
 ‘Ivan treated Victoria in the hospital for Amber.’
- b. ga-gamot-**in** ni ivan si viktor^{ia} sa klinika **para kay amber.**
 CONT-treat-PV PN.X Ivan PN.PIVOT Victoria DF.Y clinic P PN.Y Amber
 ‘Ivan will treat *Victoria* in the hospital for Amber.’
- c. pag-ga-gamot-**an** ni ivan **kay viktor**ia ang klinika **para kay amber.**
 PAG-CONT-treat-LV PN.X Ivan PN.Y Victoria PIVOT clinic P PN.Y Amber
 ‘Ivan will treat *Victoria in the hospital* for Amber.’

Malayo-Polynesian-level. In languages under the majority of Austronesian primary branches, these phrases share the same morphological marking (Y) with non-Pivot objects.

See (2) for Blust’s (2015) reconstruction of the argument-marking system of Proto-Austronesian (PAn) (2a), Proto-Malayo-Polynesian (PMP) (2b), and Proto-Philippines (PPh) (2c). Each shows a three-way distinction in the marking for Pivot, X, and Y. Although the exact morphological form of some specific slots is not reconstructable, a four-way distinction of Pivot/X/Y/locative is manifested in conservative Philippine-type languages from different Austronesian primary branches. See Blust (2015) for details.

(2) TABLE 9.2. *The argument-marking system of PAn, PMP, and PPh*²

a. Proto-Austronesian					
		Pivot	X	Y	Loc
		*s	*n	*k	*d
Singular personal name	*i	*si	*ni	(*ki)	(*di)
Plural personal name	*a	*sa	*na	[*ka]	[*da]
Common noun	*u	—	*nu	*ku	[*du]
b. Proto-Malayo-Polynesian					
		Pivot	X	Y	Loc
		*s	*n	*k	*d
Singular personal name	*i	*si	*ni	(*ki)	(*di)
Plural personal name	*a	*sa	*na	[*ka]	*da
Common noun	*u	—	*nu	*ku	[*du]
c. Proto-Philippines					
		Pivot	X	Y	Loc
		*s	*n	*k	*d
Singular personal name	*i	*si	*ni	*ki	(*di)
Plural personal name	*a	*sa	*na	(*ka)	(*da)
Common noun	*u	*su	*nu	*ku	(*du)

(3) presents the argument-marking paradigms of three Philippine-type languages (Paiwan, Amis, Botolan Sambal) from different Austronesian primary branches, each of which manifests the prototypical four-way pattern.

² According to Blust (2015), the case markers in parenthesis (*ka) and (*di) have case functions that can be reconstructed from the bottom up, but need semantic fine-tuning.

(3) TABLE 9.3. *The argument-marking pattern and pronominal paradigm of Paiwan, Amis, and Botolan Sambal*³

a. Paiwan (Paiwan)

	CN	PN (SG.)	PN (PL.)	1SG	1PL.INCL	1PL.EXCL	2SG	2PL	3SG	3PL
Pivot	<i>a</i>	<i>ti</i>	<i>tia</i>	<i>tiaken</i>	<i>tiitjen</i>	<i>tiamen</i>	<i>tisun</i>	<i>timun</i>	<i>timadju</i>	<i>tiamadju</i>
X	<i>nua</i>	<i>ni</i>	<i>nia</i>	<i>niaken</i>	<i>niitjen</i>	<i>niamen</i>	<i>nisun</i>	<i>nimun</i>	<i>nimadju</i>	<i>nimadju</i>
Y	<i>tua</i>	<i>tjay</i>	<i>tjaia</i>	<i>tjanuaken</i>	<i>tjanuitjen</i>	<i>tjanuamen</i>	<i>tjanusun</i>	<i>tjanumun</i>	<i>tjaymadju</i>	<i>tjaiamadju</i>

b. Amis (East Formosan)

	CN	PN (SG.)	PN (PL.)	1SG	1PL.INCL	1PL.EXCL	2SG	2PL	3SG	3PL
Pivot	<i>ku</i>	<i>ci</i>	<i>ca</i>	<i>kaku</i>	<i>kita</i>	<i>kami</i>	<i>kisu</i>	<i>kamu</i>	<i>cingra</i>	<i>cangra</i>
X	<i>nu</i>	<i>ni</i>	<i>na</i>	<i>aku</i>	<i>ita</i>	<i>nyam</i>	<i>isu</i>	<i>namu</i>	<i>nira</i>	<i>nangra</i>
Y	<i>tu</i>	<i>ci-...-an</i>	<i>ca-...-an</i>	<i>takuwanan</i>	<i>kitanan</i>	<i>kamiyanan</i>	<i>tisuwanan</i>	<i>tamuanan</i>	<i>cingranan</i>	<i>cangraan</i>

(c) Botolan Sambal (Malayo-Polynesian)

	CN	PN (SG.)	PN (PL.)	1SG	1PL	2SG	2PL	3SG	3PL
Pivot	<i>hay, ya</i>	<i>hi</i>	<i>hili</i>	<i>ako</i>	<i>kayi</i>	<i>ka</i>	<i>kawo</i>	<i>ya</i>	<i>hila</i>
X	<i>nin</i>	<i>ni</i>	<i>nili</i>	<i>ko</i>	<i>nawen</i>	<i>mo</i>	<i>moyo</i>	<i>na</i>	<i>la</i>
Y	<i>ha</i>	<i>koni</i>	<i>konli</i>	<i>kongko</i>	<i>konnawen</i>	<i>komo</i>	<i>komoyo</i>	<i>kona</i>	<i>konla</i>

In less conservative dialects and languages, the distinction of Pivot, X, and Y has undergone morphological syncretism. Tagalog, for instance, has partially lost the X/Y distinction in common noun marking, as in (4)⁴:

(4) TABLE 9.4. *The lack of X/Y distinction in Tagalog's common noun marking system*

	CN	PN	1SG	1PL.INCL	1PL.EXCL	2SG	2PL	3SG	3PL
Pivot	<i>ang</i>	<i>si</i>	<i>ako</i>	<i>tayo</i>	<i>kami</i>	<i>ikaw</i>	<i>kayo</i>	<i>siya</i>	<i>silá</i>
X	<i>ng</i>	<i>ni</i>	<i>ko</i>	<i>natin</i>	<i>namin</i>	<i>mo</i>	<i>ninyo</i>	<i>niya</i>	<i>nila</i>
Y	<i>ng_(ID), sa_(DF)</i>	<i>kay</i>	<i>sa akin</i>	<i>sa atin</i>	<i>sa amin</i>	<i>sa iyo</i>	<i>sa inyo</i>	<i>sa kanya</i>	<i>sa kanila</i>

The loss of the X/Y distinction as a common tendency among Philippine-type languages can be seen through a comparison of the argument-marking paradigm of Nanwang Puyuma and Katipul Puyuma. As seen in (5), the distinction has been partially lost in the innovative dialect Nanwang (5a), but it is still present in Katipul (5b):

³ CN: common noun, PN: personal name. Sources: Paiwan: A. Chang (2006); Amis: Wu (2006); Botolan Sambal: Antworth (1979).

⁴ Source: McFarland (1976).

(5) TABLE 9.5. *The argument-marking paradigm of two Puyuma dialects*⁵

a. Nanwang

	CN (DF.)	CN (ID.)	PN (SG.)	PN (PL.)
Pivot	<i>na</i>	<i>a</i>	<i>i</i>	<i>na</i>
X	<i>kana</i>	<i>dra</i>	<i>kan</i>	<i>kana</i>
Y	<i>kana</i>	<i>dra</i>	<i>kan</i>	<i>kana</i>

b. Katipul

	CN (DF.)	CN (ID.)	PN (SG.)	PN (PL.)
Pivot	<i>na</i>	<i>a</i>	<i>i</i>	—
X	<i>nina</i>	<i>za</i>	<i>ni</i>	—
Y	<i>kana</i>	<i>za</i>	<i>kani</i>	<i>kana</i>

⁵ Source: Teng (2009).

References

- Abbott, Miriam. 1991. Macushi. In Derbyshire, D. and G. Pullum (eds.), *Handbook of Amazonian Languages* Vol. 2, 23–160. Berlin/New York: Mouton de Gruyter.
- Abitov, J., B. Balkarov, Ju. D. Deleriev, G. Y. Rogava, B. Kardanov, and T. Kauševa. 1957. *Grammatika kabardino-cherkesskogo literaturnogo jazyka*. Moscow: Izdatel'stvo Akademii Nauk. bbott.
- Adelaar, Alexander. 2011. *Siraya: Retrieving the phonology, grammar and lexicon of a dormant Formosan language*. Berlin & Boston: De Gruyter Mouton.
- Aissen, Judith. 1992. Topic and Focus in Mayan. *Language* 68(1):43–80.
- Aissen, Judith. 2010. Depictives and serialization in Tzotzil. In D. Gerdts, J. Moore & M. Polinsky (eds.), *Hypothesis A/Hypothesis B, Current Studies in Linguistics*, 1–17. MIT Press.
- Aissen, Judith and David Perlmutter. 1976. Clause reduction in Spanish. In H. Thompson. et al (eds.) *Proceedings of the Second Annual Meeting of the Berkeley Linguistics* (BLS2), 1–30.
- Aissen, Judith and David Perlmutter. 1983. Clause reduction in Spanish. In D. Perlmutter (eds.), *Studies in Relational Grammar*, 360–403. University of Chicago Press
- Alboiu, Gabriela and Virginia Hill. 2013. The case of A-bar ECM: Evidence from Romanian. In S. Keine & S. Sloggett (eds.), *Proceedings of the Forty-Second Annual Meeting of the North East Linguistics Society (NELS42)*, 25–39. Amherst, MA: GSLA.
- Aldai, Gontzal. 2000. Split ergativity in Basque: the pre-Basque antipassive-imperfective hypothesis. *Folia Linguistica Historica* 31:31–97.
- Aldridge, Edith. 2004. Ergativity and Word Order in Austronesian Languages. Ph.D. dissertation: Cornell University.
- Aldridge, Edith. 2008. Generative approaches to ergativity. *Language and Linguistics Compass: Syntax and Morphology* 2.5, 966–95.
- Aldridge, Edith. 2011. Antipassive in Austronesian Alignment Change. In Dianne Jonas, John Whitman, and Andrew Garrett (eds.), *Grammatical Change: Origins, Nature, Outcomes*, 332–46. Oxford University Press.
- Aldridge, Edith. 2012. Tagalog nominalization and ergativity. Paper presented at the 19th meeting of the Austronesian Formal Linguistics Association (AFLA19). Academia Sinica, Taiwan.
- Aldridge, Edith. 2014. Ergativity from subjunctive in Austronesian languages. *Proceedings of the 14th International Symposium on Chinese Languages and Linguistics* (IsCLL 14th), Academia Sinica, Taipei, 4–6 June 2014.
- Aldridge, Edith. 2016a. Ergativity from subjunctive in Austronesian languages. *Language and Linguistics* 17(1):27–62.
- Aldridge, Edith. 2016b. ϕ -feature competition: The Austronesian extraction restriction and its origin. Talk given at the 23rd Austronesian Formal Linguistic Association (AFLA 23). Tokyo, June 10–12, 2016.
- Aldridge, Edith. 2017. Phi-Feature Competition: A unified approach to the Austronesian extraction restriction. In J. Kantarovich, T. Truong & O. Xherija (eds.), *Proceedings of the 52nd Meeting of the Chicago Linguistic Society (CLS 52)*.
- Alexiadou, Artemis. 2001. *Functional Structure in Nominals*. Amsterdam: John Benjamins.
- Alexiadou, Artemis, Elena Anagnostopoulou, and Florian Schäfer. 2006. The properties of anticausatives crosslinguistically. In Mara Frascarelli (ed.), *Phases of interpretation*, 175–99. Berlin: Mouton.
- Amberber, Mengistu. 2002. *Verb Classes and Transitivity in Amharic*. Original, Munich: Lincom Europa.
- Anagnostopoulou, Elena. 1997. Clitic left dislocation and contrastive left dislocation. In E.

- Anagnostopoulou, H. van Riemsdijk, & F. Zwats (eds.), *Materials on left dislocation*, 151–92. Amsterdam: John Benjamins.
- Anagnostopoulou, Elena. 2000. Two classes of double object verbs: The role of zero morphology. Paper presented at the 23rd GLOW Workshop on Zero-Morphology, Bilbao, April.
- Anderson, Stephen. 1976. On the notion of subject in ergative languages. In C. Li. (ed.), *Subject and topic*, 1–24. New York: Academic Press.
- Antworth, Evan. 1979. *Grammatical sketch of Botolan Sambal*. Manila: Linguistic Society of the Philippines.
- Arka, I Wayan. 2003. Voice systems in the Austronesian languages of Nusantara: Typology, symmetry and Undergoer orientation. *Linguistik Indonesia* 21(1):113–39.
- Arka, I Wayan and Christopher Manning. 2008. Voice and Grammatical Relations in Indonesian: A New Perspective. In S. Musgrave & P. Austin (eds.), *Voice and grammatical relations in Austronesian languages*, 45–69. Stanford: Center for the Study of Language.
- Baier, Nico. 2017. Antilocality and Antiagreement. *Linguistic Inquiry* 48(2):367–77.
- Bak, Sung-Yun. 1984. Why not a topic in a relative clause?. *Language research* 20(2):163–79.
- Baker, Mark. 1988. *Incorporation: A theory of grammatical function changing*. Chicago: University of Chicago Press.
- Baker, Mark. 2008. On the nature of the antiagreement effect: Evidence from *wh*-in-situ in Ibibio. *Linguistic Inquiry* 39:615–32.
- Baker, Mark. 2012. On the relationship of object agreement and accusative case: evidence from Amharic. *Linguistic Inquiry* 43:255–74.
- Barðdal, Jóhanna and Þórhallur Eythórrsson. 2012. Reconstructing Syntax: Construction Grammar and the Comparative Method. In H. Boas, & I. Sag (eds.), *Sign-Based Construction Grammar*, 257–308. Stanford: CSLI Publications.
- Barker, Chris and Geoffrey Pullum. 1990. A theory of command relations. *Linguistics and Philosophy* 13:1–34.
- Barker, Chris. 2012. Quantificational binding does not require c-command. *Linguistic Inquiry* 43(4):614–33.
- Béjar, Susana. 2003. Phi-syntax: A theory of agreement. PhD dissertation, University of Toronto.
- Bellwood, Peter. 1979. *Man's Conquest of the Pacific*. New York: Oxford University Press.
- Bellwood, Peter. 1984–5. A hypothesis for Austronesian origins. *Asian Perspectives* 26.1:107–17.
- Bellwood, Peter. 2004. The Origins and Dispersals of Agricultural communities in Southeast Asia. In I. Glover & P. Bellwood (eds.), *Southeast Asia: from prehistory to history*, 21–40. London: Routledge Curzon.
- Bellwood, Peter. 2005. *First Farmers: The Origins of Agricultural Societies*. Blackwell, Oxford.
- Bellwood, Peter. 2011. The Checkered Prehistory of Rice Movement Southwards as a Domesticated Cereal —from the Yangzi to the Equator. *Rice* 4: 93–103.
- Bittner, Maria. 1995. Quantification in Eskimo: A Challenge for Compositional Semantics. In E. Bach, E. Jelinek, A. Kratzer, & B. Partee (eds.), *Quantification in Natural Languages*, 59–80. Dordrecht: Kluwer Academic Publishers.
- Bittner, Maria and Kenneth Hale. 1996. Ergativity: Toward a Theory of a Heterogeneous Class. *Linguistic Inquiry* 27:531–604.
- Blake, Barry. 2001. *Case*. Cambridge: Cambridge University Press.
- Blust, Robert. 1977. The Proto-Austronesian pronouns and Austronesian subgrouping: a preliminary report. *Working Papers in Linguistics* 9.2:1–15. Honolulu: Department of Linguistics, University of Hawaii.

- Blust, Robert. 1984–5. The Austronesian Homeland: a linguistic perspective. *Asian Perspectives* 26:45–67.
- Blust, Robert. 1996a. Beyond the Austronesian homeland: The Austric hypothesis and its implications for archaeology. In W. Goodenough (ed.), *Prehistoric Settlement of the Pacific: 117–37. Transactions of the American Philosophical Society* 86.5. Philadelphia: American Philosophical Society.
- Blust, Robert. 1996b. Some remarks on the linguistic position of Thao. *Oceanic Linguistics* 35(2):272–94.
- Blust, Robert. 1999. Subgrouping, circularity and extinction: some issues in Austronesian comparative linguistics. In Elizabeth Zeitoun & Paul Jen-kuei Li (eds.), *Selected Papers from the Eighth International Conference on Austronesian Linguistics*, 31–94. Taipei: Institute of Linguistics, Academia Sinica.
- Blust, Robert. 2001. Malayo-Polynesian: new stones in the wall. *Oceanic Linguistics* 40:151–55.
- Blust, Robert. 2002. Notes on the history of ‘focus’ in Austronesian languages. In F. Wouk & M. Ross (eds.), *The history and typology of western Austronesian voice systems*, 63–78. Canberra: Pacific Linguistics.
- Blust, Robert. 2003a. Three notes on early Austronesian morphology. *Oceanic Linguistics* 42(2):438–78.
- Blust, Robert. 2003b. *Thao Dictionary*. Taipei: Academia Sinica.
- Blust, Robert. 2005. A Note on the History of Genitive Marking in Austronesian Languages. *Oceanic Linguistics* 44(1):215–22.
- Blust, Robert. 2013[2009]. *The Austronesian languages* (2nd edition). Canberra: Pacific Linguistics.
- Blust, Robert. 2014. Some Recent Proposals Concerning the Classification of the Austronesian Languages. *Oceanic Linguistics* 53(2):300–91.
- Blust, Robert. 2015. The Case-Markers of Proto-Austronesian. *Oceanic Linguistics* 54(2):436–91.
- Blust, Robert and Victoria Chen. 2017. The pitfalls of negative evidence: ‘Ergative Austronesian’, ‘Nuclear Austronesian’ and their progeny. *Language and Linguistics* 18(4):577–621.
- Blust, Robert and Stephen Trussel. Ongoing. The Austronesian Comparative Dictionary (ACD). <http://www.trussel2.com/ACD/>
- Bobaljik, Jonathan. 1995. Morphosyntax: The syntax of verbal inflection. PhD dissertation, MIT.
- Bobaljik, Jonathan. 2008. Where’s phi? Agreement as a post-syntactic operation. In D. Harbour, D. Adger & S. Béjar (eds.), *Phi Theory: phi-features across interfaces and modules*, 295–328. Oxford: Oxford University Press.
- Bok-Bennema, Reineke. 1991. *Case and agreement in Inuit*. Studies in Generative Grammar 38. Berlin & New York: Foris Publications.
- Bondoc, Ivan. 2015. A grammar sketch of Blaan. MA Thesis: University of the Philippines Diliman.
- Bowen, Donald. 1965. *Beginning Tagalog: A Course for Speakers of English*. University of California Press.
- Bricker, Victoria. 1981. The source of the ergative split in Yucatec Maya. *Journal of Mayan Linguistics* 2(2):83–127.
- Bruening, Benjamin. 2001. Raising to object and proper movement. Ms., University of Delaware.
- Bruening, Benjamin. 2010. Ditransitive Asymmetries and a Theory of Idiom Formation. *Linguistic Inquiry* 41(4):519–62.
- Bruening, Benjamin. 2014. Precede-and-command revisited. *Language* 90:342–88.
- Büring, Daniel. 2005. Bound to bind. *Linguistic Inquiry* 36:259–74.
- Burzio, Luigi. 1986. *Italian syntax: A Government-Binding approach*. Dordrecht: Reidel.
- Bybee, Joan. 2001. Main clauses are innovative, subordinate clauses are conservative: Consequences for the nature of constructions. In J. Bybee & M. Noonan (eds.), *Complex sentences in grammar and discourse: Essays in honor of Sandra A. Thompson*, 1–17. Amsterdam: John Benjamins.
- Bybee, Joan, Revere Perkins, and William Pagliuca. 1994. *The Evolution of Grammar: Tense, Aspect and Modality in the Languages of the World*. Chicago: University of Chicago Press.

- Bybee, Joan and Sandra Thompson. 2000. Three frequency effects in syntax. *Berkeley Linguistic Society* 23:65–85.
- Campbell, Lyle. 2000. Valency-changing Derivations in K'iche. In R. Dixon, & A. Aikhenvald (eds.), *Changing Valency: Case Studies in Transitivity*, 236–81. Cambridge: Cambridge University Press.
- Carrier-Duncan, Jill. 1985. Linking of Thematic Roles in Derivational Word Formation. *Linguistic Inquiry* 16(1), 1–34.
- Cauquelin, Josianne. 2015. *Nanwang Puyuma-English dictionary. Language and Linguistics Monograph Series* 56. Taipei: Institute of Linguistics, Academia Sinica.
- Ceña, Resty and Ricardo Nolasco. 2011. *Gramatikang Filipino: Balangkas*. Quezon City, Philippines: The University of the Philippines Press.
- Chang, Anna Hsiou-chuan. 2006. A reference grammar of Paiwan. PhD dissertation, Australian National University.
- Chang, Henry Yung-Li. 1997. Voice, case, and agreement in Seediq and Kavalan. PhD dissertation: National Tsing Hua University.
- Chang, Henry Yung-Li. 2006. Rethinking the Tsouic subgroup hypothesis: A morphosyntactic perspective. In Chang, H., L. Huang, & D. Ho (eds.), *Streams Converging into an Ocean: Festschrift in Honor of Professor Paul Jen-kuei Li on his 70th Birthday*, 565–83. Taipei: Institute of Linguistics, Academia Sinica.
- Chang, Henry Yung-li. 2009. Adverbial verbs and adverbial compounds in Tsou: A syntactic analysis. *Oceanic Linguistics* 48(2):439–76.
- Chang, Henry Yung-li. 2000. *A reference grammar of Kavalan* [in Chinese]. Taipei: Yuanliu.
- Chang, Henry Yung-li. 2011. Triadic Encoding in Tsou. *Language and Linguistics* 12.4:799–843.
- Chang, Henry Yung-li. 2013. Double transitives and double applicatives. Paper represented at A Minimalist Workshop on Austronesian Verbal Syntax. Taipei, November 15.
- Chang, Henry Yung-li. 2014. Long-distance Transitivity Agreement in Tsou: A Phase-based Account. Paper presented at the 21st Annual Meeting of the Austronesian Formal Linguistics Association (AFLA21). Honolulu, May 2014.
- Chang, Henry Yung-li. 2015. Extractions in Tsou causative applicatives. *Lingua Sinica* 1(5):1–48.
- Chang, Kuang-Chih. 1989. Taiwan archeology in Pacific perspective. In K. Chang, C. Yin, & K. Li (eds.), *Anthropological Studies of the Taiwan area: Accomplishments and Perspectives*, 87–97. Taipei: Department of Anthropology, National Taiwan University.
- Chang, Melody Ya-Yin. 2004. Subjecthood in Tsou Grammar. PhD dissertation, National Tsing-Hua University.
- Chen, Cheng-fu. 2005. Object voice and nominalization in Rukai. In J. Heinz & D. Ntelitheos (eds.), *Proceedings of AFLA XII, UCLA Working Paper in Linguistics* no.12.
- Chen, Cheng-fu. 2008. Aspect and tense in Rukai: Interpretation and interaction. PhD dissertation, University of Texas at Austin.
- Chen, Ting-chun. 2010. Restructuring in Mayrinax Atayal. BA Honors thesis: McGill University.
- Chen, Victoria. 2015. A reexamination of recent Austronesian higher-level subgroupings and the “Nominalization-into-Verb” hypothesis. Talk presented at the 13th International Conference on Austronesian Linguistics (ICAL 13). Taipei, July 18–23.
- Chen, Victoria. 2016. “Pivot” ≠ Absolutive: Evidence from Formosan. *Proceedings of 42nd Annual Meeting of the Berkeley Linguistics Society (BLS 42)*, 253–72.
- Chen, Victoria. 2017. Philippine-type voice affixes as A'-agreement morphology: Evidence from causatives. *Proceedings of the 23rd Austronesian Formal Linguistic Association (AFLA 23)*, 35–49. Canberra: Asia-Pacific Linguistics.
- Chen, Victoria and Shin Fukuda. 2015. Restructuring constructions in Formosan languages and their implications for object Case-licensing. Paper presented at the 22nd Austronesian Formal

- Linguistics Association (AFLA 22). Montréal: May 21–24.
- Chen, Victoria and Shin Fukuda. 2016a. “Absolutive” marks extractions, not Case : Against the syntactic ergative analysis for Austronesian-type voice system. *Proceedings of the 46th Annual Meeting of the North East Linguistics Society (NELS 46)*, 201–11. UMass GLSA.
- Chen, Victoria and Shin Fukuda. 2016b. Raising to object out of CP as embedded left dislocations: Evidence from three Formosan languages. *Proceedings of the 33rd West Coast Conference on Formal Linguistics (WCCFL 33)*, 88–98. Somerville, MA: Cascadilla Proceedings Project.
- Chen, Victoria and Shin Fukuda. 2017. Re-labeling “Ergative”: Evidence from Formosan. *Proceedings of the 23rd Austronesian Formal Linguistic Association (AFLA 23)*, 50–65. Canberra: Asia-Pacific Linguistics.
- Chomsky, Noam. 1977. On *wh*-movement. In A. Akmajian, P. Culicover, and T. Wasow (eds.), *Formal syntax*, 71–132. Academic Press.
- Chomsky, Noam. 1981. *Lectures on government and binding*. Dordrecht: Foris Publications.
- Chomsky, Noam. 1982. *Some concepts and consequences of the theory of government and binding*. MIT Press.
- Chomsky, Noam. 1986. *Barriers*. Cambridge, MA: MIT Press.
- Chomsky, Noam. 1995. *The Minimalist Program*. Cambridge, MA: MIT Press.
- Chomsky, Noam. 2000. Minimalist inquiries. In R. Martin, D. Michaels, & J. Uriagereka (eds.), *Step by step: Essays on minimalism in honor of Howard Lasnik*, 89–155. Cambridge: MIT Press.
- Chomsky, Noam. 2001a. Beyond explanatory adequacy. *MIT Working Papers in Linguistics* 20:1–28. Department of Linguistics and Philosophy. Cambridge, MA: MIT, Cambridge.
- Chomsky, Noam. 2001b. Derivation by phase. In M. Kenstowicz (ed.), *Ken Hale: A life in language*, 1–52. Cambridge, MA: MIT Press.
- Chomsky, Noam. 2007. Approaching UG from below. In U. Sauerland and H. Gärtner (eds.), *Interfaces + recursion = language?*, 1–29. Mouton de Gruyter.
- Chomsky, Noam. 2008. On phases. In R. Freidin, C. Otero, and M. Zubizarreta (eds.), *Foundational issues in linguistic theory: Essays in honor of Jean-Roger Vergnaud*, 133–66. MIT Press.
- Chomsky, Noam and Howard Lasnik. 1977. Filters and control. *Linguistic Inquiry* 8:425–504.
- Chung, Sandra. 1976. On the Subject of Two Passives in Indonesian. In C. Li (ed.), *Subject and Topic*, 59–98. Academic Press,
- Chung, Sandra. 1994. *Wh*-agreement and “referentiality” in Chamorro. *Linguistic Inquiry* 25(1):1–44.
- Chung, Sandra. 1998. *The design of agreement: Evidence from Chamorro*. Chicago: University of Chicago Press.
- Chung, Sandra. 2004. Restructuring and verb-initial order in Chamorro. *Syntax* 7:199–233.
- Cinque, Guglielmo. 2004. “Restructuring” and functional structure. In L. Rizzi (ed.), *The structure of CP and IP*, 132–91. New York: Oxford University Press.
- Cole, Peter. 1976. A Causative Construction in Modern Hebrew: Theoretical Implications. In P. Cole (ed.), *Studies in Modern Hebrew Syntax and Semantics*, 99–126, North Holland Publishing Co., Amsterdam.
- Collins, James. 2016. Definiteness and implicatures in Tagalog. In Clem, E. et al (eds.), *Proceedings of the 42nd Meeting of the Berkeley Linguistics Society (BLS 42)*, 273–92.
- Comrie, Bernard. 1978. Ergativity. In W. Lehmann (ed.), *Syntactic Typology*, 329–94. The Harvester Press limited.
- Coon, Jessica. 2009. Comments on Austronesian nominalism: A Mayan perspective. *Theoretical Linguistics* 35(1):73–93.
- Coon, Jessica. 2010. Complementation in Chol (Mayan): A Theory of Split Ergativity. PhD dissertation,

MIT.

- Coon, Jessica and Alan Bale. 2014. The interaction of person and number in Mi'gmaq. *Nordlyd* 40:85–101.
- Cooreman, 1994. A functional typology of antipassives. In Fox, B. & P. Hopperoice (eds.), *Form and Function* 49–88. Amsterdam: John Benjamins
- Cuervo, Maria Cristina. 2003. Datives at Large. PhD dissertation, MIT.
- Dahl, 1973. *Proto-Austronesian*. Scandinavian Institute of Asian Studies Monograph Series, No. 15. London: Curzon Press.
- Davies, William. 2005. Madurese prolepsis and its implications for a typology of raising. *Language* 81:645–65.
- De Guzman, Videia. 1976. Syntactic derivation of Tagalog verbs. PhD Dissertation: University of Hawaii.
- De Guzman, Videia. 1988. Ergative analysis for Philippine languages: an analysis. In R. McGinn (ed.), *Studies in Austronesian linguistics*, 323–45. Ohio University Press.
- De Guzman, Videia. 1992. Morphological evidence for primacy of patient as subject in Tagalog. *Papers in Austronesian linguistics* 2: 87–96.
- De Wolf, Charles. 1988. Voice in Austronesian languages of Philippine type: passive, ergative, or neither? In M. Shibatani (ed.), *Passive and Voice*, 143–93. Amsterdam and Philadelphia: John Benjamins
- DeLancey, Scott. 1984. Notes on agentivity and causation. *Studies in Language* 8: 181–213.
- Dempwelff, Otto. 1934–38. *Vergleichende Lautlehre des austronesischen Wortschatzes*. 3 Vols. *Zeitschrift für Eingeborenen-Sprachen*. Berlin: Dietrich Reimer.
- Diebold, A. Richard Jr. 1960. Determining the Centers of Dispersal of Language Groups. *International Journal of American Linguistics* 26(1):1–10.
- Dixon, Robert. 1972. *The Dyirbal language of North Queensland*. Cambridge: Cambridge University Press.
- Dixon, Robert. 1979. Ergativity. *Language* 55:59–138.
- Dixon, Robert. 1994. *Ergativity*. Cambridge: Cambridge University Press.
- Donohue, Mark. 1999. *A grammar of Tukang Besi*. Amsterdam: Mouton de Gruyter.
- Dryer, Matthew. 1990. What Determines Antipassive in Dyirbal ?. *Eastern States Conference on Linguistics (ESCOL) Proceedings* 7, 90–101.
- Duncan, Tamara Sorenson and Daniel Abera. 2009. Amharic Causatives Revisited. Poster presented at Department of Linguistics 40th Reunion, University of Alberta.
- Dyen, Isidore. 1956. Language Distribution and Migration Theory. *Language* 32(4):611–626.
- Dyen, Isidore. 1965. Formosan evidence for some new Proto-Austronesian phonemes. *Lingua* 14:285–305.
- Dyen, Isidore. 1990. Homomeric lexical classification. In P. Baldi (ed.), *Linguistic change and reconstruction methodology*, 211–30. *Trends in Linguistics Studies and Monographs* 45. Berlin and New York: Mouton de Gruyter.
- England, Nora. 1988. Mam Voice. In M. Shibatani (ed.), *Passive and Voice*, 525–45. Amsterdam: John Benjamins.
- Erlewine, Michael, Theodore Levin, and Coppe van Urk. 2017. Ergativity and Austronesian-type voice systems. In J. Coon, D. Massam, and L. Travis (eds.), *Oxford Handbook of Ergativity*. Oxford University Press.
- Erlewine, Michael. To appear. Subject marking on non-subjects in Squiliq Atayal." *Proceedings of the 20th Austronesian Formal Linguistics Association (AFLA 20)*.
- Escamilla, Ramón. 2012. The Syntactic Causative Construction in Hupa (California Athabaskan). *Rice Working Papers in Linguistics* vol. 3, Spring 2012.
- Estioca, Sharon. Forthcoming. The binding parameter in Subanon. *University of Hawai'i at Mānoa: Working Papers in Linguistics*.

- Evans, Nicholas and Honoré Watanabe. 2007. The dynamics of insubordination: An overview. In N. Evans, & H. Watanabe (eds.), *Insubordination*, 1–38. Amsterdam and Philadelphia: John Benjamins.
- Felser, Claudia and Anja Wanner. 2001. The Syntax of Cognate Objects and Other Unselected Objects. In N. Dehe, and A. Wanner (eds.), *Structural Aspects of Semantically Complex Verbs*, 105–30. Frankfurt, Bern & New York: Peter Lang.
- Ferrell, Raleigh. 1969. *Taiwan aboriginal groups: problems in cultural and linguistic classification*. Institute of Ethnology, Academia Sinica, Monograph no. 17. Taipei: Academia Sinica.
- Ferrell, Raleigh. 1971. Aboriginal peoples of the southwestern Taiwan plain. *Bulletin of the Institute of Ethnology, Academia Sinica* 32: 217–35.
- Ferrell, Raleigh. 1979. Construction Markers and Subgrouping of Formosan Languages. In N. Liem (ed.), *Southeast Asian Linguistic Studies* Vol. 3, 199–212. Pacific Linguistics, the Australian National University.
- Foley, William. 1998. Symmetrical voice systems and precategoriality in Philippine languages. Paper presented at The Third Lexical Functional Grammar Conference, Brisbane, 30 June–2 July, 1998.
- Foley, William. 2005. Semantic parameters and the unaccusative split in the Austronesian language family. *Studies in Language* 29(2):385–430
- Foley, William. 2008. The place of Philippine languages in a typology of voice systems. In P. Austin, and S. Musgrave (eds.), *Voice and grammatical relations in Austronesian languages*, 22–44. Stanford: CSLI Publications.
- Foley, William and Robert Van Valin. 1984. *Functional syntax and universal grammar*. Cambridge, England: Cambridge University Press.
- Folli, Raffaella and Heidi Harley. 2007. Causation, obligation, and argument structure: on the nature of little v. *Linguistic Inquiry* 38(2):197–238.
- Fox, Danny. 1999. Reconstruction, binding theory and the interpretation of chains. *Linguistic Inquiry* 30:157–96.
- Frank, Robert and K. Vijay-Shanker. 2001. Primitive c-command. *Syntax* 4.164–204.
- Freidin, Robert. 1986. Fundamental issues in the theory of binding. In B. Lust (ed.), *Studies in the acquisition of anaphora*, 151–88. Reidel.
- Georgala, Efthymia, Waltraud Paul, and John Whitman. 2008. Expletive and thematic applicatives. In C. Chang & Hannah Haynie (eds.), *Proceedings of the 26th West Coast Conference on Formal Linguistics (WCCFL 26)*, 181–89. Somerville: Cascadilla Press.
- Georgala, Efthymia. 2012. *Applicatives in their structural and thematic function: A minimalist account of multitransitivity*. PhD dissertation: Cornell University.
- Gerds, Donna. 1980. Antipassives and causatives in Halkomelem. In *Proceedings of the 6th Annual Meeting of the Berkeley Linguistics Society* (BLS 6), 300–14.
- Gerds, Donna. 1988. Antipassives and causatives in Ilokano: evidence for an ergative analysis. In R. McGinn (ed.), *Studies in Austronesian linguistics*, 295–321. Athens, OH: Ohio University Center for International Studies.
- Gil, David. 2009. Austronesian Nominalism and the Thinginess Illusion. *Theoretical Linguistics* 35(1):95–114.
- Gildea, Spike. 1998. *On Reconstructing Grammar*. New York: Oxford University Press.
- Givón, Talmy. 1979. *On understanding grammar*. New York: Academic Press.
- Givón, Talmy. 1983. Topic continuity in discourse: An introduction. In T. Givón (ed.), *Topic continuity in discourse: A quantitative cross-language study*, 1–41. Amsterdam: John Benjamins.
- Givón, Talmy. 2005. *The diachrony of Grammar*, Vol. 2. Amsterdam: John Benjamins.
- Givón Talmy. 2015. Nominalization, de-subordination and re-finitization. *The diachrony of grammar*, vol. 2, 661–91. Amsterdam: John Benjamins.
- Grodzinsky, Yosef and Tanya Reinhart. 1993. The innateness of binding and coreference. *Linguistic*

Inquiry 24:69–101.

- Guilfoyle, Eithne, Henrietta Hung, and Lisa Travis. 1992. Spec of IP and Spec of VP: Two subjects in Austronesian languages. *Natural Language and Linguistic Theory* 10:375–414.
- Guirardello, Raquel. 1999. Trumai. In R. Dixon and A. Aikhenvold (eds), *The Amazonian languages*, 351–3. Cambridge: Cambridge University Press.
- Gundel, Jeanette. 1974. The role of topic and comment in linguistic theory. PhD dissertation: University of Texas, Austin.
- Gundel, Jeanette. 1988. Universals of topic-comment structure. In M. Hammond et al. (eds.), *Studies in Syntactic Typology*, 209–39. Amsterdam: John Benjamins.
- Hale, Kenneth and Samuel Keyser. 1997. The limits of argument structure. In A. Mendikoetxea & M. Uribe-Etxebarria (eds.), *Theoretical issues at the morphology-syntax interface*, 203–30. Servicio de Publicaciones de la UPV, Bilbao.
- Halle, Morris. 1992. The Latvian declension. In G. Booij & J. van Marle (eds.), *Yearbook of Morphology* 1991, 33–48. Dordrecht: Kluwer.
- Halle, Morris. 1997. Distributed Morphology: Impoverishment and fission. In B. Bruening, Y. Kang, & M. McGinnis (eds.), *MIT Working Papers in Linguistics 30, PF: Papers at the interface*, 425–50.
- Halle, Morris and Alec Marantz. 1993. Distributed Morphology and the pieces of inflection. In K. Hale, & S. Keyser (eds.), *The view from Building 20*:111–76. Cambridge, MA: MIT Press.
- Halle, Morris and Alec Marantz. 1994. Some key features of Distributed Morphology. In A. Carnie & H. Harley, *MIT Working Papers in Linguistics 21: Papers on phonology and morphology*, 275–88. Cambridge, Mass.: MITWPL.
- Halpert, Claire and Jochen Zeller. 2015. Right dislocation and raising-to-object in Zulu. *The Linguistic Review* 32(3): 475–513.
- Harley, Heidi. 1995. Subjects, Events and Licensing. PhD dissertation, MIT.
- Harley, Heidi. 2008. On the causative construction. In S. Miyagawa & M. Saito (eds.), *Handbook of Japanese Linguistics*, 20–53, Oxford: OUP.
- Harley, Heidi. 2013. External arguments and the mirror principle: on the distinctness of Voice and v. *Lingua* 125:34–57.
- Harves, Stephanie. 2002. Genitive of negation and the syntax of scope. In M. Koppen et al. (eds.), *Proceedings of ConSOLE*:96–110.
- Harvey, Mark. 1982. Subgroups in Austronesian. In A. Halim, L. Carrington, and S. Wurm (eds.) *Papers from the Third International conference on Austronesian Linguistics* Vol. 2:47–99.
- Hasegawa, Nobuko. 2004. Unaccusative Transitives' and Burzio's Generalization. In *Proceedings of the Workshop on Altaic Formal Linguistics 1. MIT Working Papers in Linguistics* 46:300–14.
- Haspelmath, Martin. 1993. More on the typology of inchoative/causative verb alternations. In B. Comrie & M. Polinsky (eds.), *Causativity and transitivity*, 87–120. Amsterdam: John Benjamins.
- Heaton, Raina. 2017. A typology of antipassives, with special reference to Mayan. PhD dissertation, University of Hawai'i at Mānoa.
- Higgins, Roger. 1981. Proleptic objects and verbs of perception in Zacapoaxtla Nahuat. *Texas Linguistic Forum* 18, 69–88.
- Himmelman, Nikolaus. 1991. The Philippine challenge to universal grammar. *Arbeitspapier, Institut für Sprachwissenschaft, Universität Köln*, vol. 15, Köln: *Allgemeine Sprachwissenschaft, Institut für Linguistik, Universität zu Köln*, 1–59.
- Himmelman, Nikolaus. 2002. Voice in Western Austronesian: An update. In F. Wouk & M. Ross (eds.), *The history and typology of Western Austronesian voice systems*, 7–15. Canberra: Pacific Linguistics.
- Himmelman, Nikolaus. 2005. The Austronesian languages of Asia and Madagascar: Typological characteristics. In A. Adelaar & N. Himmelman (eds.), *The Austronesian languages of Asia and*

- Madagascar*, 110–81. *Routledge: Language Family Series*, vol. 7. New York: Routledge.
- Himmelman, Nikolaus. 2008. Lexical categories and voice in Tagalog. In P. Austin & Simon Musgrave (eds.), *Voice and Grammatical Functions in Austronesian Languages*, 247–93. CSLI, Stanford.
- Himmelman, Nikolaus. 2009. Lexical categories and voice in Tagalog. *Theoretical Linguistics* 35(1):115–23.
- Ho, Dah-an. 1978. A preliminary comparative study of five Paiwan dialects. *Bulletin of the Institute of History and Philology, Academia Sinica* 49: 565–681.
- Ho, Dah-an. 1998. Genetic relationships among the Formosan languages [in Chinese]. *Chinese Studies* 16(2):141–71.
- Hock, Hans. 1986. *Principles of historical linguistics*. Berlin: Mouton de Gruyter.
- Hohulin, E. Lou and Hohulin, Richard. Tuwali Ifugao Dictionary. SIL 2014. <http://tuwali-ifugao.webonary.org>
- Holmberg, Anders. 1986. Word Order and Syntactic Features in the Scandinavian Languages and English. PhD dissertation, University of Stockholm.
- Holmer, Arthur. 1999. Structural implications of the function of Instrument Focus in Seediq. In P. Li & E. Zeitoun (eds.), *Selected papers from 8ICAL*, 423–54. Taipei: Institute of Linguistics, Academia Sinica.
- Hong, Ki-Sun. 1990. Subject-to-Object Raising in Korean. In K. Dziwirek, P. Farrell, and E. Mejias-Bikandi (eds.), *Grammatical Relations: A Cross-Theoretical Perspective*, 215–25. Stanford: CSLI Publications.
- Hopper, Paul and Sandra Thompson. 1980. Transitivity in grammar and discourse. *Language* 56:251–99.
- Hsieh, Henrison. Distinguishing nouns and verbs: Against nominalism for Tagalog. In Clem, E. et al. (eds.), *Proceedings of the 42nd Annual Meeting of the Berkeley Linguistics Society (BLS 42)*, 313–36.
- Huang, Lillian Mei-jin. 1994. Ergativity in Atayal. *Oceanic Linguistics* 33(1):129–43.
- Huang, Lillian Mei-jin. 1995. *A study of Mayrinax syntax*. Taipei: Crane Publishing.
- Huang, Lillian Mei-jin. 2001. Focus system of Mayrinax Atayal: A syntactic, semantic and pragmatic perspective. *Journal of Taiwan Normal University: Humanities & Social Science* 46:51–69.
- Huang, Shuan-fan. 2005. Split O in Formosan languages—A localist interpretation. *Language and Linguistics* 6:783–806.
- Ippolito, Michela. 2000. Remarks on the argument structure of Romance causatives. Ms., MIT.
- Jeffers, Robert. 1976. Syntactic Change and Syntactic Reconstruction. In W. Christie (ed.), *Current Progress in Historical Linguistics: Proceedings of the Second International Conference on Historical Linguistics*, 1–15. Amsterdam: North-Holland.
- Jiang, Hao-wen. 2016. Nominalization and possession in Formosan languages. PhD dissertation, Rice University.
- Jiao, Tian-long and Guo Zhengfu. 2014. Kuahuqiao and the Early Neolithic Seafaring in Southeast China. Paper presented at the 2014 International Symposium on the Studies of Prehistoric Cultural and Physical Remains. Taipei, September 2014.
- Johns, Alana. 1992. Deriving ergativity. *Linguistic Inquiry* 23:57–88.
- Johns, Alana. 2000. Ergativity: a perspective on recent work. In L. Cheng & R. Sybesma (eds.), *The first glot international state-of-the-article book*, 47–73. New York: Mouton de Gruyter.
- Jones, Michael Allen. 1988. Cognate Objects and the Case Filter. *Journal of Linguistics* 24, 89–111.
- Jónsson, Jóhannes Gisli. 1996. Clausal architecture and Case in Icelandic. PhD dissertation, University of Massachusetts, Amherst.
- Juge, Matthew. 2002. Unidirectionality in grammaticalization and lexical shift: The case of English rather. In J. Larson & M. Paster (eds.), *Proceedings of the Twenty-Eighth Annual Meeting of the Berkeley Linguistics Society (BLS 28)*, 147–54. Berkeley: Berkeley Linguistics Society.

- Kallulli, Dalina. 2005 Unaccusatives with overt Causers and Experiencers: A Unified Account. In D. Hole, & A. Meinunger (eds.), *Datives and Similar Cases*. Amsterdam: John Benjamins.
- Kano, Tadao & Kokichi Segawa. 1945. *An Illustrated Ethnography of Formosan Aborigines: Vol. 1 the Yami*. Tokyo: Maruzen.
- Katagiri, Masumi. 2006. Topichood of the Philippine topic: Revisited from a cross-linguistic perspective. Paper presented at the 10th ICAL. January 17–20.
- Kaufman, Daniel. 2009. Austronesian nominalism and its consequences: A Tagalog case study. *Theoretical Linguistics* 35(1):1–49.
- Kaufman, Daniel. 2017. Lexical category and alignment in Austronesian. In J. Coon, D. Massam, and L. Travis (eds.), *Oxford Handbook of Ergativity*. MA: Oxford University Press.
- Kayne, Richard. 1975. *French Syntax: The Transformational Cycle*. Cambridge, Massachusetts: The MIT Press.
- Keenan, Edward. 1976. Remarkable subjects in Malagasy. In Li, C. (ed.), *Subject and topic*, 247–301. New York: Academic Press.
- Kikusawa, Ritsuko. 2012. On the development of applicative constructions in Austronesian languages. *Osaka: Bulletin of the National Museum of Ethnology* 36:413–55.
- Kiss, Katalin. 1995. Introduction. In Kiss, K. (ed.), *Discourse-Configurational Languages*, 3–28. Oxford University Press.
- Klein-Andreu, Flora. 1990. Losing ground: a discourse-pragmatic solution to the history of *-ra* in Spanish. In S. Fleischman & L. Waugh (eds.), *Discourse-pragmatics and the verb: evidence from Romance*, 164–78. London: Routledge.
- Ko, Albert Min-Shan et al. Early Austronesians: into and out of Taiwan. *The American Journal of Human Genetics* 94:426–36.
- Kornfilt, Jaklin and Omer Preminger. To appear. Nominative as no case at all: an argument from raising-to-accusative in Sakha. *Proceedings of the 9th Workshop on Altaic Formal Linguistics*. Cambridge, MA: MITWPL.
- Kratzer, Angelika. 1996. Severing the external argument from its verb. In J. Rooryck & Zaring (ed.), *Phrase structure and the lexicon*, 109–37. Dordrecht, The Netherlands: Kluwer Academic Publishers.
- Kroeger, Paul. 1991. Phrase structure and grammatical relations in Tagalog. PhD dissertation: Stanford University.
- Kroeger, Paul. 1993. *Phrase Structure and Grammatical Relations in Tagalog*. Stanford, CA: Center for the Study of Language and Information, Stanford University.
- Kroeger, Paul. 2008. Result complex predicates in Kimaragang Dusun. In P. Quick & J. Smith (eds.), *10-ICAL Borneo, Sulawesi, and Philippines papers. Studies in Philippine Languages and Cultures* 19:30–54.
- Kroeger, Paul. 2009. Malagasy clefts from a Western Malayo-Polynesian perspective: Commentary on the paper by Hans-Martin Gärtner. *Natural Language and Linguistic Theory*:817–38.
- Kroeger, Paul. 2014. An affectedness constraint in Kimaragang restructuring. In M. Butt & T. Holloway King (eds.), *Proceedings of the LFG14 Conference*, 283–303. Stanford, CA: CSLI Publications.
- Kuno, Susumu. 1973. *The Structure of the Japanese Language*. Cambridge, MA: MIT Press.
- Kuno, Susumu. 1976. Subject raising. In M. Shibatani (ed.), *Syntax and semantics 5: Japanese generative grammar*, 17–50. New York: Academic Press.
- Kuno, Susumu and Ken-ichi Takami. 2004. *Functional constraints in grammar: On the unergative-unaccusative distinction*. Amsterdam: John Benjamins.
- Kuo, Cheng-chuen. 2015. Argument alternation and argument structure in symmetrical voice languages: a case study of transfer verbs in Amis, Puyuma, and Seediq. PhD dissertation, University of Hawai'i at Manoa.

- Kuo, Su-chiu. 2014. Archeological Cultures of Taiwan and Southeast China around 4,000 B.P. Paper presented at the 2014 International Symposium on the Studies of Prehistoric Cultural and Physical Remains. Taipei, September 2014.
- Kurniawan, Eri. 2012. Does Sundanese have prolepsis and/or raising-to-object constructions? *Proceedings of the 18th Annual Meeting of the Austronesian Formal Linguistics Society (AFLA 18)*, 16-30. Online publication hosted by the University of Western Ontario.
- Kuroda, Yuki. 1965. Generative Grammatical Studies in the Japanese Language. PhD Dissertation: MIT.
- LaPolla, Randy and C.-L Huang. 1996. *A grammar of Qiang with annotated texts and glossary*. Berlin: Mouton de Gruyter.
- Lasnik, Howard and Tim Stowell. 1991. Weakest crossover. *Linguistic Inquiry* 22(4):687–720.
- Lasnik, Howard. 1976. Remarks on coreference. *Linguistic Analysis* 2:1–22.
- Lasnik, Howard. 1989. On the necessity of binding conditions. In H. Lasnik (ed.), *Essays on anaphora*, 149–72. Dordrecht: Reidel.
- Laughren, Mary. 1992. Secondary predication as a diagnostic of underlying structure in Pama-Nyungan languages. In I. Roca (ed.), *Thematic structure: Its role in grammar*, 199–246. Berlin:Foris.
- Law, Paul. 2011. Raising in Tagalog. In M. Washburn et al. (eds.), *Proceedings of the 28th West Coast Conference on Formal Linguistics (WCCFL 28)*, 142–51. Somerville, MA: Cascadilla Proceedings Project.
- Lebeaux, David. 1998. *Where does binding theory apply? Technical report*. NEC Research Institute.
- Lee, J.-H. 1992. *Hyentaykwuke mwunpeplon* [Modern Korean grammar]. Seoul: Korean Textbooks Company.
- Legate, Julie Anne. 2002. Warlpiri: Theoretical Implications. PhD dissertation, MIT.
- Legate, Julie Anne. 2003. Some Interface Properties of the Phase. *Linguistic Inquiry* 34.3:506–16.
- Legate, Julie Anne. 2008. Morphological and Abstract Case. *Linguistic Inquiry* 39:55–101.
- Legate, Julie Anne. 2012. Types of ergativity. *Lingua* 122:181–91.
- Legate, Julie Anne. 2014. *Voice and little v: lessons from Acehnese*. Cambridge, MA: MIT Press.
- Lepofsky, Dana. 1988. The environmental context of Lapita settlement locations. In P. Kirch & T. L. Hunt (eds.), *Archeology of the Lapita Cultural Complex: A critical Review*, 33–48. Thomas Burke Memorial Washington State Museum Research Report No.5. Seattle: The Burke Museum.
- Levin, Beth, and Malka Rappaport Hovav. 1995. *Unaccusativity: At the syntax-lexical semantics interface*. Cambridge, MA: MIT Press.
- Levin, Beth, Malka Rappaport Hovav. 2005. *Argument realization*. New York: Cambridge University Press.
- Levin, Beth. 1993. *English verb classes and alternations: a preliminary investigation*. Chicago: University of Chicago Press.
- Li, Chao-lin. 2009. The syntax of prefix concord in Saaroa: Restructuring and Multiple Agreement. *Oceanic Linguistics* 48:172–212.
- Li, Charles and Sandra Thompson. 1976. Subject and topic: a new typology of language. In C. Li (ed.), *Subject and Topic*, 457–61. Austin: University of Texas Press.
- Li, Paul Jen-kuei, and Shigeru Tsuchida. 2006. *Kavalan Dictionary*. Taipei: Institute of Linguistics, Academia Sinica.
- Li, Paul Jen-kuei. 1973. *Rukai Structure*. Special Publications No. 64. Taipei: Institute of History and Philology, Academia Sinica.
- Li, Paul Jen-kuei. 1977. The internal relationships of Rukai. *Bulletin of the Institute of History and Philology, Academia Sinica* 48(1)–92.
- Li, Paul Jen-kuei. 1980. The phonological rules of Atayal dialects. *Bulletin of the Institute of History and Philology, Academia Sinica* 51(2):349–405.

- Li, Paul Jen-kuei. 1985. The position of Atayal in the Austronesian family. In A. Pawley & L. Carrington (eds.), *Austronesian Linguistics at the 15th Pacific Science Congress. Pacific Linguistics, C-88*: 257–80.
- Li, Paul Jen-kuei. 1990. Classification of Formosan languages: Lexical evidence. *Bulletin of the Institute of History and Philology, Academia Sinica* 61(4):813–48.
- Li, Paul Jen-kuei. 2001. The dispersal of the Formosan aborigines in Taiwan. *Language and Linguistics* 2(1):271–78.
- Li, Paul Jen-kuei. 2004. Origins of the East Formosan peoples: Basay, Kavalan, Amis and Siraya. *Language and Linguistics* 5(2):363–76.
- Li, Paul Jen-kuei. 2008. The great diversity of Formosan languages. *Language and Linguistics* 9(3):523–46.
- Li, Paul Jen-kuei. 2010. Origins and dispersal of the Formosan natives in the east coast. *Taiwan Journal of Indigenous Studies* 3(4):1–9.
- Liao, Hsiu-chuan. 2004. Transitivity and Ergativity in Formosan and Philippine Languages. PhD dissertation, University of Hawai'i at Mānoa.
- Liao, Hsiu-chuan. 2011a. Some morphosyntactic differences between Formosan and Philippine languages. *Language and Linguistics* 12(4):845–76.
- Liao, Hsiu-chuan. 2011b. On the development of comitative verbs in Philippine languages. *Language and Linguistics* 12(1):205–37.
- Lightfoot, David W. 2002. Myths and the prehistory of grammars. *Journal of Linguistics* 38,113–36.
- Lin, Dong-yi. 2011. A syntactic account of interrogative verbs in Kavalan. Paper presented at the 47th Annual Meeting of the Chicago Linguistic Society (CLS47). April 7–9.
- Lin, Dong-yi. 2013. Interrogative constructions in Kavalan and Amis. PhD dissertation, University of Florida.
- Lin, Gu-jing. 2010. Argument Structure of Tsou: Simplex and Complex Predicates. PhD dissertation, Rice University.
- Lin, Tai. 2001. *Isbukun: A Study of Bunun Morphology* [in Chinese]. Taipei: Duce.
- Liu, Dorinda Tsai-hsiu. 2011. Complementation in Three Formosan Languages - Amis, Mayrinax Atayal and Tsou. PhD dissertation, University of Hawaii at Manoa.
- Liu, Yi-Chang et al. 1996. *Zhisanyan wenhua shiji gongyuan shiqian wenhua renwen lishi shijujinguan deng ziyuan ji jumin ziyuan zhi peiyu*. Taipei: Department of Civil Affairs, Taipei Municipal Government.
- Liu, Yi-Chang. 2002. *Danshui hekou de shiqian wenhua yu zuqun*. Taipei: The Shisanhang Museum of Archeology.
- Mabuchi, Tōichi. 1953. Migration and distribution of the Formosan aborigines Part I [in Japanese]. *Minzokugaku Kenkyu* 18(1-2):123–54;18.4:23–72.
- Mabuchi, Tōichi. 1960. The aboriginal peoples of Formosa. In G. Murdock (ed.), *Social Structure in Southeast Asia*:127–40. Chicago: Quadrangle.
- Macfarland, Talke. 1995. Cognate Objects and the Argument/Adjunct Distinction in English. PhD Dissertation: Northwestern University, Evanston Illinois.
- Maclachlan, Anna. 1996. Aspects of Ergativity in Tagalog. PhD dissertation, McGill University.
- Maclachlan, Anna and Nakamura . 1993. An economy account of wh-extraction in Tagalog. In *Proceedings of the 12th Meeting of the West Coast Conference of Linguistics (WCCFL12)*. Stanford: CSLI.
- Maclachlan, Anna and Masanori Nakamura. 1997. Case-checking and Specificity in Tagalog. *The Linguistic Review* 14.307–33.
- Mahajan, Anoop. 1989. Agreement and agreement phrases. In I. Laka & A. Mahajan (eds.), *Functional heads and clause structure*, 217–52. *MIT Working Papers in Linguistics* 10.

- Mahdi, Waruno. 1996. Another Look at Proto-Austronesian *d and *D. In B. Nothofer (ed.), *Reconstruction, Classification, Description— Festschrift in Honor of Isidore Dyen*, 1–14. Hamburg: Abera Network: Asia-Pacific.
- Maling, Joan. 2002. To be an Oblique Subject: Russian Vs. Icelandic. *Natural Language and Linguistic Theory* 20(4):691–724.
- Manning, Christopher. 1996. *Ergativity: Argument structure and grammatical relations*. CSLI, Stanford University.
- Marantz, Alec. 1984. *On the Nature of Grammatical Relations*. Cambridge, MA: MIT Press.
- Marantz, Alec. 1991. Case and licensing. In G. Westphal, B. Ao, and H. Chae (eds.), *Eastern States Conference on Linguistics*, 234–53. University of Maryland, Baltimore: Ohio State University.
- Marantz, Alec. 1993. Implications of Asymmetries in Double Object Constructions. In A. Mchombo (ed.), *Theoretical Aspects of Bantu Grammar*, 113–50. Stanford, California, CSLI Publications.
- Marantz, Alec. 1997. No escape from syntax: Don't try morphological analysis in the privacy of your own lexicon. In Dimitriadis, A. (eds.), *University of Pennsylvania Working Papers in Linguistics* 42:201–25.
- Massam, Diane. 1985. Case Theory and the Projection Principle. PhD dissertation, MIT.
- Massam, Diane. 1990. Cognate Objects as Thematic Objects. *Canadian Journal of Linguistics* 35(2):161–90.
- Matasovic, Ranko. 2010. *A short grammar of East Circassian (Kabardian)*. Zagreb.
- Matsuda, Kenjiro. 1993. Dissecting analogical leveling quantitatively: The case of the innovative potential suffix in Tokyo Japanese. *Language variation and change* 5:1–34.
- Matsuda, Kenjiro. 1998. On the conservatism of embedded clauses. *Theoretical and applied linguistics at Kobe Shain I*: 1–13.
- McFarland, Curtis. 1976. *A Provisional Classification of Tagalog Verbs*. Tokyo: Institute for the Study of Languages and Cultures of Asia and Africa.
- McKaughan, Howard. 1973. Subject versus topic. In A. Gonzalez (ed.), *Parangal kay Cecilio Lopez: Essays in honor of Cecilio Lopez on his seventy-fifth birthday*. *Philippine Journal of Linguistics Special Issue*.
- Megerdooimian, Karine. 2005. Transitivity alternation verbs and causative constructions in Eastern Armenian. *Proceedings of Annual Meeting of Armenian Linguistics* 24, 13–33.
- Merchant, Jason. 2008. An Asymmetry in Voice Mismatches in VP-ellipsis and Pseudogapping. *Linguistic Inquiry* 9(1):169–79.
- Mills, Roger. 1975. Proto South Sulawesi and Proto Austronesian phonology. PhD dissertation, The University of Michigan at Ann Arbor.
- Mintz, Malcolm. 1971. *Bikol Grammar Notes*. Honolulu: University of Hawaii Press.
- Mithun, Marianne. 1994. The implications of ergativity for a Philippine voice system. In B. Fox & P. Hopper (eds.), *Voice: Form and Function*, 247–77. Amsterdam: John Benjamins.
- Mithun, Marianne. 2008. The extension of dependency beyond the sentence. *Language* 81(1):69–119.
- Mittwoch, Anita. 1998. Cognate objects as reflections of Davidsonian event arguments. In S. Rothstein (ed.), *Events and grammar*, 309–32. Dordrecht: Kluwer.
- Miyagawa, Shigeru. 2010. *Why Agree? Why Move?* Cambridge, MA: MIT Press.
- Miyagawa, Shigeru. 2017. *Agreement Beyond Phi*. Cambridge, MA: MIT Press.
- Miyagawa, Shigeru. To appear. Topicalization. Tokyo: Gengo Kenkyu (Linguistic Research).
- Moore, John. 1998. Turkish Copy-Raising and A-Chain Locality. *Natural Language and Linguistic Theory* 16: 149–89.
- Nakajima, Heizo. 2006. Adverbial Cognate Objects. *Linguistic Inquiry* 37(4):674–84.
- Nanke Archeological Team. 2002. *Jinnian lai nanke kaogu de yixie chengguo ji qi suo yinqi de yixie wenti*.

- Nash, Lea. 1996. The internal ergative subject hypothesis. In K. Kusumoto (ed.), *Proceedings of the 26th Annual Meeting of the North East Linguistics Society (NELS 26)*, 195–09. Amherst: University of Massachusetts, GLSA.
- Naylor, Paz. 1995. Subject, topic and Tagalog syntax. In D. Bennett, T. Bynon, & G. Hewitt (eds.), *Subject, voice and ergativity: Selected essays*, 161–201. London: School of Oriental and African Studies, University of London.
- Neeleman, Ad. 1994. Scrambling as a D-Structure Phenomenon. In N. Corver & H. van Riemsdijk (eds.), *Studies on Scrambling*, 387–429. Berlin: Mouton de Gruyter.
- Nevins, Andrew. 2007. The representation of third person and its consequences for person-case effects. *Natural Language & Linguistic Theory* 25:273–313.
- Nichols, Johanna. 1997. Modeling Ancient Population Structures and Movement in Linguistics. *Annual Review of Anthropology* 26:359–384.
- Nolasco, Ricardo. 2009. What Philippine Ergativity Really Means. ms, University of the Philippines, Diliman.
- Noyer, Rolf. 1997. *Features, positions and affixes in autonomous morphological structure*. New York: Garland.
- O'Brien, Colleen. 2016. Are Philippine Languages Ergative? Evidence from Western Subanon. *University of Hawai'i at Mānoa: Working Papers in Linguistics* 47(2).
- Obata, Miki. 2010. Root, successive-cyclic and feature-splitting Internal Merge: Implications for feature-inheritance and transfer. PhD dissertation, University of Michigan.
- Obata, Miki and Samuel David Epstein. 2011. Feature-splitting Internal Merge: Improper movement, intervention, and the A/A' distinction. *Syntax* 14:122–47.
- Öhl, Peter. 2010. Formal and Functional Constraints on Constituent Order and their Universality. In C. Breul (ed.), *Comparative and Contrastive Studies of Information Structure*, 231–75. Amsterdam: John Benjamins.
- Online Dictionary of Formosan languages (ODFL). <http://e-dictionary.apc.gov.tw>
- Ouali, Hamid. 2008. On C-to-T Phi-Feature Transfer: the nature of Agreement and Anti-Agreement in Berber. In R. D'Alessandro, S. Fischer, & G. Hrafnbjargarson (eds.), *Agreement restrictions*, 159–80. Berlin: Walter de Gruyter.
- Ouhalla, Jamal. 1993. Subject-extraction, negation and the anti-agreement effect. *Natural Language and Linguistic Theory* 11:477–518.
- Ouhalla, Jamal. 2005. Agreement features, agreement and antiagreement. *Natural Language and Linguistics Theory* 23:655–86.
- Owens, Jonathan, 1985. *A Grammar of Harar Oromo (Northeastern Ethiopia)*. Hamburg: Buske.
- Paul, Ileana. 1999. Malagasy Clause Structure. PhD dissertation, McGill University.
- Paul, Ileana and Lucie Rabaovololona 1998. Raising to object in Malagasy. In *The structure of Malagasy*, vol. 2. *UCLA Occasional Papers in Linguistics* 20, 50–64.
- Paul, Ileana and Lisa Travis. 2006. Ergativity in Austronesian languages: What it can do, what it can't do, but not why. In A. Johns, D. Massam, and J. Ndayiragije (eds.), *Ergativity: emerging issues*, 315–36. Springer.
- Payne, Audrey and Dorothy Drew. 1970[2009]. *Kamano Grammar Sketch*. SIL - Papua New Guinea. http://www-01.sil.org/pacific/png/pubs/928474531295/Kamano_Grammar.pdf
- Payne, Thomas. 1982. Role and reference related subject properties and ergativity in Yup'ik Eskimo and Tagalog. *Studies in Language* 6:75–106.
- Payne, Thomas. 1994. The pragmatics of voice in a Philippine language: Actor-focus and goal-focus in Cebuano narrative. In T. Givon (ed.), *Voice and inversion, Typological Studies in Language*, 317–64. Amsterdam/Philadelphia: John Benjamins Publishing Company.
- Pearson, Matthew. 2001. The clause structure of Malagasy: A minimalist approach. PhD dissertation,

UCLA.

- Pearson, Matthew. 2005. The Malagasy subject/topic as an A'-element. *Natural Language & Linguistic Theory* 23:381–457.
- Pearson, Matthew. 2016. Voice and aspectual focus in Malagasy. Paper presented at the 23rd Meeting of the Austronesian Formal Linguistics Association (AFLA 23). Tokyo: June 10.
- Pereltsvaig, Asya. 2012. *Languages of the World. An Introduction*. Cambridge: Cambridge University Press.
- Perlmutter, David. 1978. Impersonal Passives and the Unaccusative Hypothesis. In Farrell, A. and J. Jaeger (eds.), *Proceedings of the 4th Annual Meeting of the Berkeley Linguistics Society (BLS 4)*, 157–89. Department of Linguistics, Berkeley: University of California.
- Pesetsky, David and Esther Torrego. 2006. Probes, Goals and Syntactic Categories. In Y. Otsu (ed.), *Proceedings of the 7th annual Tokyo Conference on Psycholinguistics*. Tokyo: Hituzi Syobo Publishing Company..
- Pham, Hoa. 1999. Cognate objects in Vietnamese transitive verbs. *Toronto Working Papers in Linguistics* 17:227–46.
- Phillips, Colin. 2003. Linear order and constituency. *Linguistic Inquiry* 34:37–90.
- Polinsky, Maria. 2016. *Deconstructing Ergativity: Two Types of Ergative Languages and Their Features*. Oxford: Oxford University Press.
- Polinsky, Maria. To appear. Syntactic ergativity. In M. Everaert & H. van Riemsdijk (eds.), *Blackwell companion to syntax* (2nd Edition). Blackwell Publishers.
- Polinsky, Maria and Eric Potsdam. 2001. Long-distance agreement and topic in Tsez. *Natural Language and Linguistic Theory* 19, 583–646.
- Postal, Paul. 1971. *Cross-over phenomena*. Holt, Rinehart and Winston.
- Postal, Paul. 1993. Remarks on Weak Crossover effects. *Linguistic Inquiry* 24:539–56.
- Potsdam, Eric. 2006. The Cleft Structure of Malagasy Wh-Questions. In H. Gärtner, P. Law, and J. Sabel (eds.), *Clause Structure and Adjuncts in Austronesian Languages*., 195–232. Berlin: Mouton de Gruyter.
- Potsdam, Eric. 2009. Austronesian Verb-Initial Languages and Wh-Question Strategies. *Natural Language and Linguistic Theory* 27:737–71.
- Potsdam, Eric and Jeffrey Runner. 2001. Richard returns: Copy Raising and its implications. In M. Andronis, C. Ball, H. Elston, & S. Neuvel (eds.), *CLS 37: The Main Session* vol. 1:453–68. Chicago, IL: Chicago Linguistic Society.
- Preminger, Omer. 2011. Agreement as a fallible operation. PhD dissertation, MIT.
- Pylkkänen, Liina. 2002. Introducing arguments. PhD dissertation, MIT.
- Rackowski, Andrea. 2002. The Structure of Tagalog: Specificity, Voice, and the Distribution of Arguments. PhD dissertation, MIT.
- Rackowski, Andrea and Norvin Richards. 2005. Phase edge and extraction: A Tagalog case study. *Linguistic Inquiry* 36(4):565–99.
- Rafal, Jeremy. 2009. Analyzing Ilokano Pseudoclefts. *University of Pennsylvania Working Papers in Linguistics* Vol. 15(1), Article 20.
- Reid, Lawrence. 1979. Evidence for Proto-Philippine nominative marking. *Philippine Journal of Linguistics* 10(1-2):1–20.
- Reid, Lawrence. 1982. The demise of Proto-Philippines. In A. Halim, L. Carrington, and S. Wurm (eds.) *Papers from the Third International conference on Austronesian Linguistics*, vol 2: Tracking the travelers, 201–16. Canberra: Pacific Linguistics.
- Reid, Lawrence. 1994. Morphological evidence for Austric. *Oceanic Linguistics* 33(2):323–44.
- Reid, Lawrence. 2002. Determiners, nouns, or what? Problems in the analysis of some commonly occurring forms in Philippine languages. *Oceanic Linguistics* 41:295–309.

- Reinhart, Tanya. 1976. The syntactic domain of anaphora. PhD dissertation, MIT.
- Reinhart, Tanya. 1983. Anaphora and semantic interpretation. Chicago: University of Chicago Press.
- Reinhart, Tanya. 2000. The Theta System: Syntactic realization of verbal concepts, *OTS Working papers. 00.01/TL*.
- Reinhart, Tanya and Eric Reuland. 1993. Reflexivity. *Linguistic Inquiry* 24:657–720.
- Richards, Marc. 2007. On feature inheritance: an argument from the phase impenetrability condition. *Linguistic Inquiry* 38:563–72.
- Richards, Norvin. 1997. What moves where when in which language? PhD Dissertation: MIT.
- Richards, Norvin. 2000. Another look at Tagalog subjects. In I. Paul, V. Phillips, & L. Travis (eds.), *Formal issues in Austronesian linguistics*, 105–16. Dordrecht: Kluwer Academic Publishers.
- Richards, Norvin. 2009. Nouns, verbs, and hidden structure in Tagalog. *Theoretical Linguistics* 35(1):139–52.
- Riesberg, Sonja. 2014. *Symmetrical Voice and Linking in Western Austronesian Languages*. Berlin: De Gruyter Mouton.
- Rizzi, Luigi. 1978. A Restructuring Rule in Italian Syntax. In S. Keyser (ed.), *Recent Transformational Studies in European Languages*, 113–58. Cambridge: MIT Press.
- Rizzi, Luigi. 1982. A restructuring rule. In Rizzi, L. (eds.), *Issues in Italian syntax*, 1–76. Dordrecht: Foris.
- Rizzi, Luigi. 1990. *Relativized minimality*. Cambridge, MA: MIT Press.
- Roeper, Tom. 1987. Implicit arguments and the head-complement relation. *Linguistic Inquiry* 18(2): 267–310.
- Rolett, Barry, Zhuo Zheng, and Yuanfu Yue. 2011. Holocene sea-level change and the emergence of Neolithic seafaring in the Fuzhou Basin (Fujian, China). *Quaternary Science Reviews* 30:788–97.
- Rolett, Barry. 2007. Southeast China and the emergence of Austronesian Seafaring. In T. Jiao (eds.), *Lost Maritime Cultures: China and the Pacific*, 54–61. Bishop Museum Press, Honolulu.
- Ross, Malcolm. 2002a. The history and transitivity of Western Austronesian voice and voice-marking. In Wouk, F. & M. Ross (eds.), *The history and typology of Western Austronesian voice systems*, 17–62. Canberra: Pacific Linguistics.
- Ross, Malcolm. 2002b. Final words: Research themes in the history and typology of western Austronesian languages. In F. Wouk & M. Ross (eds.), *The History and Typology and Western Austronesian Voice Systems*, 451–74. Canberra: Pacific Linguistics.
- Ross, Malcolm. 2006. Reconstructing the case-marking and personal pronoun systems of Proto Austronesian. In H. Chang, L. Huang and D. Ho (eds.), *Streams converging into an ocean: festschrift in honor of Professor Paul Jen-kuei Li on his 70th birthday*, 521–63. Taipei: Institute of Linguistics, Academia Sinica.
- Ross, Malcolm. 2009. Proto Austronesian verbal morphology: a reappraisal. In K. Alexander Adelaar & Andrew Pawley (eds.), *Austronesian Historical Linguistics and Culture History: A Festschrift for Robert Blust*:295–326. Canberra: Pacific Linguistics.
- Ross, Malcolm. 2012. In Defense of Nuclear Austronesian (and Against Tsouic). *Language and Linguistics* 13(6):1253–330.
- Ross, Malcolm. 2014. Major morphosyntactic changes in early Austronesian. Lectures in Workshop on Advanced Linguistics: Language Change, Academia Sinica. July 14-24, 2014.
- Rouveret, Alain and Jean-Roger Vergnaud. 1980. Specifying reference to the subject: French causatives and conditions on representations. *Linguistic Inquiry* 11:97–202.
- Rubino, Carl. 2000. Ilocano Dictionary and Grammar: Ilocano-English, English-Ilocano. PALI Language Texts. Honolulu: University of Hawaii Press.
- Ruys, Eddy. 2004. A note on Weakest Crossover. *Linguistic Inquiry* 35:124–40.
- Sagart, Laurent. 2004. The higher phylogeny of Austronesian and the position of Tai-Kadai. *Oceanic*

Linguistics 43(2):411–44.

- Sagart, Laurent. 2008. The expansion of setaria farmers in East Asia: a linguistic and archaeological model. In A. Sanchez-Mazas, R. Blench, M. Ross, I. Peiros and M. Lin (eds.), *Past human migrations in East Asia: matching archaeology, linguistics and genetics*:133–57. London: Routledge.
- Sagart, Laurent. 2010. Is Puyuma a primary branch of Austronesian? *Oceanic Linguistics* 49(1):194–204.
- Sagart, Laurent. 2013. Is Puyuma a Primary Branch of Austronesian?: A Rejoinder. *Oceanic Linguistics* 52(2):481–92.
- Sagart, Laurent. 2014. In defense of the numeral-based model of Austronesian phylogeny, and of Tsouic. *Language and Linguistics* 15(6):859–82.
- Sapir, Edward. 1916. *Time perspective in aboriginal American culture, a study in method*. Ottawa, Government Printing Bureau.
- Sasaki, Miyuki. 1990. Topic prominence in Japanese EFL students' existential constructions. *Language Learning* 40, 337–68.
- Sasse, Hans-Jürgen. 1995. Prominence Typology. In J. Jacobs et al. (eds.): *Syntax. An International Handbook of Contemporary Research*, 1065–75. Berlin: de Gruyter.
- Schachter, Paul and Fe T. Otnes. 1972. *Tagalog reference grammar*. Berkeley: University of California Press.
- Schachter, Paul. 1976. The subject in Philippine languages: Topic, actor, actor-topic, or none of the above? In C. Li (eds.), *Subject and topic*, 491–518.
- Schachter, Paul. 1977. Reference-related and role-related properties of subjects. In P. Cole and J Saddock (eds.), *Grammatical Relations*, 279–306. New York: Academic Press.
- Schäfer, Florian. 2008. *The Syntax of (Anti-)Causatives. External Arguments in Change-of-state Contexts*. Amsterdam: John Benjamins.
- Sheehan, Michelle and Sonia Cyrino. 2016. Variation and change in the Romance faire-par causative. In E. Carrilho et al. (eds.), *Romance Languages and Linguistic Theory*, 279–304. John Benjamins.
- Shi, Chao-Kai. 2014. Restructuring and vP-internal structure in Takibakha Bunun. Paper presented at the Minimalist Workshop on Formosan Infinitives, Academia Sinica, Taipei, Taiwan, December 13.
- Shibatani, Masayoshi. 1976. On Japanese Causative: Review of Shibatani's Notion of Causative. *Syntax and semantics* 6, 1–42. New York: Academic Press.
- Shibatani, Masayoshi. 1988. Voice in Philippine languages. In M. Shibatani (ed.), *Passive and voice*, 85–142. Amsterdam: John Benjamins.
- Silva-Corvalán, Carmen. 1978. The Ilokano Causative in Universal Grammar. In J. Jaeger et al. (eds.), *Proceedings of the 4th Annual Meeting of the Berkeley Linguistics Society (BLS 4)*, 223–38.
- Sportiche, Dominique. 1992. 'Clitics, Voice, and Spec-head Licensing', *GLOW Newsletter* 28, 46–7.
- Spreng, Bettina. 2001. Little v in Inuktitut: antipassive revisited. *Linguistica Atlantica* 23:155–90.
- Starke, Michal. 2001. Move dissolves into Merge: A theory of locality. PhD dissertation, University of Geneva.
- Starosta, Stanley. 1985. Verbal inflection versus deverbal nominalization in PAN: the evidence from Tsou. In A. Pawley & L. Carrington (eds.), *Austronesian Linguistics at the 15th Pacific Science Congress*, 281–312. *Pacific Linguistics* C-88. Canberra: The Australian National University.
- Starosta, Stanley. 1995. A grammatical subgrouping of Formosan languages. In P. Li, C. Tsang, Y. Huang, D. Ho, and C. Tseng (eds.), *Austronesian studies relating to Taiwan*:683–726. Symposium Series of the Institute of History and Philology, Academia Sinica, no. 3. Taipei: Academia Sinica.
- Starosta, Stanley. 1988/2009. A grammatical typology of Formosan languages. *Bulletin of the Institute of History and Philology, Academia Sinica* 59(2):541–76. (Republished in E. Zeitoun (ed.), *Formosan linguistics: Stanley Starosta's contributions*, 267–96. Taipei: Academia Sinica, 2009.)
- Starosta, Stanley, Andrew Pawley, and Lawrence A. Reid. 1981. The evolution of focus in Austronesian.

- Paper presented at the Third International Conference on Austronesian Linguistics, Bali.
- Starosta, Stanley, Andrew Pawley, and Lawrence Reid. 1982. The evolution of focus in Austronesian. In A. Halim, L. Carrington & S. Wurm (eds.), *Papers from the Third International Conference on Austronesian Linguistics*, Vol. 2, 145–70. Canberra: Pacific Linguistics. Reprinted in E. Zeitoun, (ed.) 2009, *Formosan Linguistics: Stanley Starosta's Contributions*, 297–328.
- Stiebels, Barbara. 2006. Agent Focus in Mayan languages. *Natural Language and Linguistic Theory* 24(2): 501–70.
- Suzuki, Sakutarō. 1932. *A Study of Taiwan Aborigines* [in Japanese]. Taipei: Taiwan Shiseki kankōkai.
- Suzuki, Tadasu. 1999. *Taiwan aborigines — Social life and customs* [in Chinese]. Taipei: Taiyuan.
- Svenonius, Peter. 2001. Case and event structure. In N. Zhang (ed.), *ZAS Papers in Linguistics* 26.
- Tada, Hiroaki. 1993. A/A-bar partition in derivation. PhD dissertation, MIT
- Tanaka, Hidekazu. 2002. Raising to object out of CP. *Linguistic Inquiry* 33:637–652.
- Tanaka, Nozomi. 2016. An asymmetry in the acquisition of Tagalog relative clauses. PhD dissertation, University of Hawaii at Manoa.
- Tanankingsing, Michael. 2009. A Functional reference Grammar on Cebuano. PhD dissertation, National Taiwan University.
- Teng, Stacy Fang-ching. 2008. *A grammar of Puyuma, an Austronesian language of Taiwan*. Canberra: Australian National University.
- Teng, Stacy Fang-ching. 2009. Case Syncretism in Puyuma. *Language and Linguistics* 10(4):819–44.
- Teng, Stacy Fang-ching. 2016. Aspectual split ergative pattern in Puyuma: synchronic and diachronic. *Proceedings of the 11th International Symposium on Taiwanese languages and Teaching*, 353–75.
- Teng, Stacy Fang-ching and Elizabeth Zeitoun. 2016. Noun-verb distinction in Kanakanavu and Saaroa: evidence from pronouns. *Oceanic Linguistics* 55(1):134–61.
- Teng, Stacy Fang-ching and Malcolm Ross. 2010. Is Puyuma a primary branch of Austronesian? A reply to Sagart. *Oceanic Linguistics* 49(2):543–58.
- Tian, Zhe-yi. 2001. *Taiwan aborigines: societies and cultures* [in Chinese]. Taipei: Wuling.
- Ting, Pang-hsin. 1976. Reconstruction of Proto-Puyuma Phonology [in Chinese]. *Bulletin of the Institute of History and Philology Academia Sinica* 49-3:321–92.
- Topping, Donald M. (with the assistance of Bernadita C. Dungca). 1973. *Chamorro reference grammar*. PALI Language texts: Micronesia. Honolulu: The University Press of Hawaii.
- Travis, Lisa. 2000. The 1-syntax, s-syntax boundary: evidence from Austronesian. In I. Paul, V. Phillips, and L. Travis (eds.), *Formal Issues in Austronesian Linguistics*, 167–94. Dordrecht: Kluwer Academic Publishers.
- Travis, Lravis. 2001. Derived Objects in Malagasy. In W. Davies & S. Dubinsky (eds.), *Objects and Other Subjects*. Dordrecht, Kluwer Academic Publishers.
- Travis, Lisa. 2010. *Inner Aspect*. Dordrecht: Springer.
- Tsang, Cheng-hwa. 2005. Recent discoveries at the Tapenkeng culture sites in Taiwan: implications for the problem of Austronesian origins. In L. Sagart, R. Blench & A. Sanchez-Mazas (eds.), *The peopling of East Asia: putting together archaeology, linguistics and genetics*, 63–73. London and New York: Routledge Curzon.
- Tsang, Cheng-hwa et al. 1994. *Taimin diqu kaogu pucha: Gaoxiong Xian he Gaoxiong Shi*. Taipei: Ministry of Interior Affairs.
- Tsang, Cheng-hwa, C.- T. Li and C.Y. Chu. 2004. *Report on the Daoye site, Tainan Science-Based Industrial Park* (in Chinese). Taipei,: Academia Sinica.
- Tsuchida, Shigeru. 1976. *Reconstruction of Proto-Tsouic phonology*. Tokyo: *Study of Languages and Cultures of Asia & Africa Monograph Series* no. 5. Tokyo: Institute for the Study of Languages

and Cultures of Asia and Africa.

- Tsuchida, Shigeru. 1980. *Puyuma (Tamalakaw dialect) vocabulary*. Tokyo: Kadokawa Shoten.
- Tsuchida, Shigeru. 1985. Kulon: Yet another Austronesian language in Taiwan?. *Bulletion of the Institute of Ethnology*, 60:1–59
- Tsukida, Naomi. 2009. “*Seediq Grammar*” ([Grammar of the Seediq language]). PhD dissertation, University of Tokyo.
- Tsukida, Naomi. 2015. Ditransitive alignment and causative in Seediq. In E. Zeitoun, S. Teng, and J. Wu (eds.), *New advances in Formosan linguistics*, 223–51. Canberra: Asia Pacific Linguistics.
- Tubino Blanco, Mercedes. 2010. *Contrasting Causatives: A Minimalist Approach*. PhD dissertation, University of Arizona.
- Ura, Hiroyuki. 2000. *Checking theory and grammatical functions in universal grammar*. New York: Oxford University Press.
- Ura, Hiroyuki. 1998. Checking, economy, and copy-raising in Igbo. *Linguistic Analysis* 28:67–88.
- van Riemsdijk, Henk and Edwin Williams. 1981. NP-structure. *The Linguistic Review* 1:171–217.
- van Urk, Coppe. 2015. *A uniform syntax for phrasal movement: A case study of Dinka Bor*. PhD dissertation, MIT.
- van Urk, Coppe and Norvin Richards. 2015. Two components of long-distance extraction: Successive cyclicity in Dinka. *Linguistic Inquiry* 46:113–55.
- Vennemann, Theo. 1975. An explanation of drift". In Li, C. (ed.), *Word order and word order change*, 267–305. Austin: University of Texas Press.
- Walkden, George. 2013. The correspondence problem in syntactic reconstruction. *Diachronica* 30(1):95–122.
- Wasow, Thomas. 1972. *Anaphoric Relations in English*. PhD dissertation, MIT.
- Wechsler, Stephen and I Wayan Arka. 1998. Syntactic ergativity in Balinese: an argument structure based theory. *Natural Language & Linguistic Theory* 16(2): 387–442.
- Winter, Werner. 1984. Reconstructing Comparative Linguistics and the Reconstruction of the Syntax of Undocumented Stages in the Development of Language and Language Families. In J. Fisiak (ed.), *Historical syntax*, 613–26. Berlin: Mouton de Gruyter.
- Wolff, John. 1973. Verbal inflection in Proto-Austronesian. In A. Gonzalez (ed.), *Parangal kay Cecilio Lopez: essays in honor of Cecilio Lopez on his seventy-fifth birthday*:71–91. Special Monograph Issue no.4. Quezon City: Linguistic Society of the Philippines.
- Woolford, Ellen. 2006. Lexical Case, Inherent Case, and Argument Structure. *Linguistic Inquiry* 37:111–30.
- Wouk, Faye and Malcolm Ross, eds. 2002. *The history and typology of Western Austronesian voice systems*. Canberra: Pacific Linguistics.
- Wu, Chun-ming. 2012. *The Syntax of Linking Constructions in Mayrinax Atayal and Sinvaudjan Paiwan*. PhD dissertation, National Tsing-hua University.
- Wu, Chun-ming, Henry chang, and Huiwen Cheng. 2014. Mayrinax purposives restructuring, finite complementation and nominalization. Paper presented at the 21st Annual Meeting of the Austronesian Formal Linguistics Association (AFLA21). Honolulu, May 2014.
- Wu, Hsiao-hung. 2011. Restructuring and Clause Structure in Isbukun Bunun. *Oceanic Linguistics* 52(1): 69–85.
- Wu, Jing-lan. 2006. *Verb classification, case marking, and grammatical relations in Amis*. PhD dissertation, State University of New York at Buffalo.
- Wu, Ming-yi. 2013. *Amis Dictionary* [in Chinese]. Taipei: Nantien.
- Wurmbrand, Susi. 2001. *Infinitives: Restructuring and Clause Structure*. New York, NY: Mouton de

Gruyter.

- Wurmbrand, Susi. 2014. Restructuring across the world. In L. Veselovská & M. Janebová (eds.): *Complex Visibles Out There. Proceedings of the Olomouc Linguistics Colloquium 2014: Language Use and Linguistic Structure*, 275–94. Olomouc: Palacký University.
- Yeh, M.-C. 2000. Shiqianguan Kaogu shinian gongzuo jianjie. *Wenhua Yizhan* 10:1–7.
- Yeh, Mei-li. 2000. *A reference grammar of Saisiyat* [in Chinese]. Taipei: Yuanliu.
- Yeh, Mei-li. 2016. *A reference grammar of Saisiyat* [in Chinese]. Taipei: Council of Indigenous People.
- Yeh, M.-C. 2000. Shiqianguan Kaogu shinian gongzuo jianjie. *Wenhua Yizhan* 10:1–7.
- Yoon, James. 2007. Raising of major arguments in Korean (and Japanese). *Natural Language and Linguistic Theory* 25(3):615–53.
- Zeitoun, Elizabeth. 2000a. *A Reference Grammar of Bunun* [in Chinese]. Taipei: Yuanliu.
- Zeitoun, Elizabeth. 2000b. *A reference grammar of Rukai* [in Chinese]. Taipei: Yuanliu.
- Zeitoun, Elizabeth. 2000c. *A reference grammar of Tsou* [in Chinese]. Taipei: Yuanliu.
- Zeitoun, Elizabeth. 2007. *A Grammar of Mantauran (Rukai)*. Taipei: Institute of Linguistics, Academia Sinica.
- Zeitoun, Elizabeth. 2016. A comparative study of nominalization in Rukai. Paper Read at the 11th International Symposium on Taiwanese Languages and Teaching. Taipei: July 12–13.
- Zeitoun, Elizabeth and Stacy Fang-ching Teng. 2014. The position of Kanakanavu and Saaroa within the Formosan languages revisited. Paper presented at the 14th International Symposium on Chinese Languages and Linguistics (IsCLL14th). Taipei: June 4–6.
- Zeitoun, Elizabeth and Stacy Fang-ching Teng. 2016. Reassessing the Position of Kanakanavu and Saaroa among the Formosan Languages. *Oceanic Linguistics* 55(1):163–98.
- Zeitoun, Elizabeth, Tai-hwa Chu, and Lalo a Tahesh Kaybaybaw. 2015. *A Study of Saisiyat Morphology*. *Oceanic Linguistics Special Publication* no. 40. Honolulu: University of Hawai‘i Press.
- Zeller, Jochen. 2009. On clitic left dislocation in Zulu. In S. Ermisch (ed.), *Focus and Topic in African Languages*, 131–56. Koeln: Ruediger Koeppel Verlag.