

CHARGE, COLLOIDAL, AND STRUCTURAL STABILITY
INTERRELATIONSHIPS FOR SELECTED HAWAII SOILS

A THESIS SUBMITTED TO THE GRADUATE DIVISION OF THE
UNIVERSITY OF HAWAII IN PARTIAL FULFILLMENT
OF THE REQUIREMENTS FOR THE DEGREE OF

MASTER OF SCIENCE

IN

AGRONOMY AND SOIL SCIENCE

AUGUST 1975

By

Kato Tama

Thesis Committee:

Samir A. El-Swaify, Chairman
Rollin C. Jones
Edgar W. Dangler

We certify that we have read this thesis and that in our opinion it is satisfactory in scope and quality as a thesis for the degree of Master of Science in Agronomy and Soil Science.

THESIS COMMITTEE

Samir A. El-Swaify

Chairman

Edgar W. Doughter

Rollin C. Jones

TABLE OF CONTENTS

	<u>Page</u>
LIST OF TABLES	vi
LIST OF ILLUSTRATIONS	vii
INTRODUCTION	1
LITERATURE REVIEW	
A. Theory of the Electrical Double Layer	4
1. Historical background.	4
2. The diffuse double layer in the absence of specific adsorption	5
3. The double-layer with specific adsorption.	9
B. The Reversible Double Layer at the Oxide- Solution Interface	10
1. The positive surface charge.	13
2. The zero point of charge (ZPC)	16
3. The negative surface charge.	16
4. Potential and charge distribution at the oxide-solution interface	19
C. Colloidal Stability and Flocculation Phenomena	21
1. Interaction between similar particles.	21
2. Interaction of double layers on the basis of Stern's theory.	27
3. Interaction between dissimilar particles	28
D. The Electrochemical Properties of Soil Colloids.	33
1. Colloids with constant surface charge.	33
2. Colloids with constant surface potential	34
E. Applicability of Concepts to Soils	37
MATERIALS AND METHODS	
A. Description of Soils	41
1. Hilo silty clay - Inceptisol	41
2. Molokai silty clay - Oxisol	42
3. Waikane silty clay - Ultisol	43

TABLE OF CONTENTS (Continued)

	<u>Page</u>
B. Experimental Methods	44
1. Characterization of samples.	44
2. Preparation of soil materials for surface charge and colloidal stability measurements.	45
3. Supporting electrolytes	45
4. Surface charge measurements - the potentiometric method	46
5. Colloidal stability measurements	47
6. Particle - size analysis	48
 RESULTS AND DISCUSSION	
A. Characterization of Soil Samples	51
B. Surface Charge Measurements - Results.	55
1. Surface charge-pH curves in the presence of KCl	55
2. Surface charge-pH curves in KCl plus CaCl ₂	63
3. Surface charge-pH curves in KCl plus K ₂ SO ₄	70
4. Surface charge-pH curves in KCl plus CaSO ₄	79
C. Surface Charge Measurements - Discussions.	79
1. Clay mineralogy and surface charge characteristics.	79
2. Effect on the surface charge of different ions in solution	91
3. Probable charging mechanisms	96
D. Colloidal Stability Measurements - Results	98
1. Hilo soil.	99
2. Waikane soil	102
3. Molokai soil	102
E. Colloidal Stability - Discussions.	107
F. Particle-Size Analysis - Results	111
1. Hilo soil.	111
2. Waikane soil	115
3. Molokai soil	115

TABLE OF CONTENTS (Continued)

	<u>Page</u>
G. Particle-Size Analysis - Discussions	122
1. Practical application of stability concepts	122
2. Implications to practical agriculture.	123
SUMMARY AND CONCLUSIONS	127
BIBLIOGRAPHY.	129

LIST OF TABLES

Table	<u>Page</u>
1A. Important soil properties--Characteristics of original soil samples.	52
1B. Important soil properties--Total chemical analysis of the untreated soils.	53
1C. Important soil properties--Estimated content of major minerals identified by X-ray analysis. . .	54
2. Zero point of charge (ZPC) values of soil colloids suspended in different supporting electrolytes	62
3. Net charge in the presence of different electrolyte combinations	94
4A. Particle-size distribution of the original soils dispersed at different pH values--Hilo soil	114
4B. Particle-size distribution of the original soils dispersed at different pH values--Waikane soil.	118
4C. Particle-size distribution of the original soils dispersed at different pH values--Molokai soil.	121

LIST OF ILLUSTRATIONS

Page

Figure

1.	Schematic representation for a negative surface of the potential, ψ , and charge, σ , distribution in the double layer according to the G.C.S.G. model.	11
2.	The process by which a surface charge is established on oxides.	14
3.	Reactions at the oxide-solution interface when anions (H_2PO_4^-) are specifically adsorbed	17
4.	Schematic representation of the net interaction energy, V_T , as a function of particle separation	25
5.	Schematic representation of the repulsive energy, V_R , for a given value of K when the potential of the particles is varied	30
6.	Electric potential, ψ , and charge, σ , distribution in the diffuse layer at two electrolyte concentrations for constant surface potential and constant surface charge colloids .	35
7A.	Surface charge-pH curves at different concentrations of KCl--Hilo soil.	56
7B.	Surface charge-pH curves at different concentrations of KCl--Waikane soil	58
7C.	Surface charge-pH curves at different concentrations of KCl--Molokai soil	60
8A.	Surface charge-pH curves at different concentrations of KCl + CaCl_2 --Hilo soil.	64
8B.	Surface charge-pH curves at different concentrations of KCl + CaCl_2 --Waikane soil	66
8C.	Surface charge-pH curves at different concentrations of KCl + CaCl_2 --Molokai soil	68
9.	Surface charge-pH curves for the Hilo soil at different concentrations of CaCl_2	71

LIST OF ILLUSTRATIONS (Continued)

Figure	<u>Page</u>
10A. Surface charge-pH curves at different concentrations of KCl + K ₂ SO ₄ --Hilo soil	73
10B. Surface charge-pH curves at different concentrations of KCl + K ₂ SO ₄ --Waikane soil.	75
10C. Surface charge-pH curves at different concentrations of KCl + K ₂ SO ₄ --Molokai soil.	77
11A. Surface charge-pH curves at different concentrations of KCl + CaSO ₄ --Waikane soil.	80
11B. Surface charge-pH curves at different concentrations of KCl + CaSO ₄ --Molokai soil.	82
12A-12B. Surface charge-pH curves at two electrolyte concentrations as a function of different ions in the supporting electrolyte--Hilo soil	84
12C-12D. Surface charge-pH curves at two electrolyte concentrations as a function of different ions in the supporting electrolyte--Waikane soil.	86
12E-12F. Surface charge-pH curves at two electrolyte concentrations as a function of different ions in the supporting electrolyte--Molokai soil.	88
13A. Colloidal stability diagram as a function of different concentrations of KCl and pH--Hilo soil	100
13B. Colloidal stability diagram as a function of different concentrations of KCl and pH--Waikane soil.	103
13C. Colloidal stability diagram as a function of different concentrations of KCl and pH--Molokai soil.	105

LIST OF ILLUSTRATIONS (Continued)

	<u>Page</u>
Figure	
14A. Percent of less than 2 μm soil fractions remaining in suspension as a function of the pH at which dispersion was effected--Hilo soil.	112
14B. Percent of less than 2 μm soil fractions remaining in suspension as a function of the pH at which dispersion was effected--Waikane soil.	116
14C. Percent of less than 2 μm soil fractions remaining in suspension as a function of the pH at which dispersion was effected--Molokai soil.	119

INTRODUCTION

The physico-chemical properties of soils are essentially determined by the so-called colloidal phase. The most important of these colloidal size particles are the layered silicate clay minerals, the humus compounds, the crystalline and non-crystalline oxides and hydrous oxides of aluminum, iron, titanium, and manganese, and the amorphous silicates.

The planar surfaces of the silicate clay minerals normally carry permanent negative charges as a result of isomorphous substitution of cations in the tetrahedral or octahedral positions. Positive charges may develop on the edges owing to proton association on the hydroxyl groups of the octahedral or tetrahedral sheets (Schofield, 1949). Nonetheless, the net charge on the clay mineral particles is nearly always negative and little dependent on the chemical composition of the soil solution. The remaining colloids are amphoteric, that is, they act as proton acceptors in low pH media thus acquiring net positive charges, and act as proton donors in media of high pH thus acquiring net negative charges.

In the pH range under normal field conditions, the oxides and hydrous oxides of aluminum and iron and amorphous silicates are generally positively charged, the layered silicates on the other hand are negatively charged. The limited data available indicate that the humus compounds could also be negatively charged under similar conditions (Greenland, 1965a, 1965b; Martin et al., 1960a, 1960b; Hussain et al., 1970). The charge contrast between the various soil

constituents leads to two important interaction phenomena, namely, reduction in cation exchange capacity, and promotion of soil aggregation through the mutual flocculation of oppositely charged particles.

In soils where conditions favor the accumulation of oxides and amorphous constituents, the consequences of interactions between the various constituents become of great importance. In temperate humid climates, such soils may be present only in low lands where iron and aluminum have been supplied by ground water. On the other hand, there exist extensive areas in the humid tropics in which soils are rich in aluminum and iron due to intensive weathering of primary minerals and leaching of silica. The silicate clay minerals present in these soils, if any, are nearly always 1:1 layered silicate clays.

It is possible to predict the behavior of soils if the parameters which control the electrochemical properties of the major colloidal constituents are known. Therefore by identifying the factors most effective in controlling the sign and magnitude of the surface charge associated with aluminum and iron compounds, behavior of soils rich in these compounds could be predicted. These factors have been summarized by Parks (1965, 1967). Experimental findings indicate that the two ions most effective in producing or modifying the surface charge of simple metal oxides are H^+ and OH^- (Parks et al., 1962; Yopps et al., 1964; Atkinson et al., 1967 among others). Investigations on the charge characteristics of oxidic soils showed similar dependences on H^+ and OH^- (Schofield, 1949; Van Raij et al., 1972; Keng, 1974; Stoop, 1974; El-Swaify et al., 1975). These findings

imply that not only the ion holding capacity, but also the structural and flocculation-dispersion behavior of oxidic soils will be directly influenced by soil pH.

The main objectives of the present study were to investigate:

1. The charge characteristics of three Hawaiian soils representing tropical Inceptisols, Ultisols, and Oxisols, as a function of pH and varying electrolyte composition.
2. The interrelationship between charge characteristics and colloidal stability for fine separates from the above soils.
3. Applicability of colloidal stability concepts to practical determinations of particle-size distribution in the soils.

LITERATURE REVIEW

A. Theory of the Electrical Double Layer

1. Historical background

The present understanding of the double layer phenomena has largely stemmed from investigations on mercury in contact with an aqueous electrolyte solution. Models of the double layer go back to Helmholtz (1853) and Quincke (1861) (cited by Delahay, 1966). The first detailed model, however, was developed independently by Gouy (1910) and Chapman (1913). Further modification of the simple Gouy-Chapman theory was introduced by Stern (1924) who considered adsorption effects which could not be interpreted in terms of the simple electrostatic interactions analyzed by Gouy and Chapman. Stern thus introduced the concept of specific adsorption and gave it a mathematical formulation based on the Langmuir isotherm. Successful verification of the theory was not possible however until Grahame (1941-1949) (Delahay, 1966) perfected the technique of measuring the double layer capacity by introducing the use of the dropping mercury electrode. Grahame (34) further hypothesized that the compact double layer capacity is only dependent on the charge on the electrode and not on the electrolyte concentration. This hypothesis was the key to experimental verification of the double layer theory.

Besides mercury, double layers on other systems were also being investigated although the data were not extensive nor accurate. A well investigated example to date is that of the reversible interface between silver iodide and an aqueous electrolyte solution. The

theory dealing with the double layer on silver iodide has been considered in detail by Mackor (52), Overbeek (59), and, more recently by Lyklema and co-workers (51). The principles derived from these studies consequently provided the informations for interpretation of the double layer on oxides by Parks and de Bruyn (62). The interpretation of the double layer at the oxide-solution interface will be discussed later in greater detail as it provides important implications regarding the electrochemical properties of the oxidic soils of Hawaii.

2. The diffuse double layer in the absence of specific adsorption

The first widely accepted quantitative treatment of the double layer was given independently by Gouy and Chapman. Their model, though it had a number of defects, still provides the quantitative basis for theoretical treatment of the double layer.

Potential and charge distribution according to the Gouy-Chapman theory. The concentration of the counterions (counter charge) tends to be greatest near the particle surface, and decreases with increasing distance from the surface. The resulting ionic distribution around the charged particle is actually the result of two competitive forces; the first is electrostatic and tends to attract the counter ions to the oppositely charged surface, and the second is kinetic which produces a tendency for ions to diffuse away from the surface where their concentration is lower. The resulting equilibrium distribution of counter ions is often referred to as the "diffuse or Gouy layer." The following treatment of the potential and charge distribution around charged colloidal particles as given

by Overbeek (59) and El-Swaify (25) considers an infinitely large plate-plate distance. For curved interfaces, the treatment is not different in principle, however, the mathematical treatment is considerably more difficult.

The potential gradient between the charged particle and any point in the system around it is given by Poisson's equation:

$$\nabla^2 \Psi = \frac{-4\pi\rho}{D}$$

Ψ = the potential, which changes from ψ_0 at the particle surface to zero in the bulk solution (1)

ρ = the volume charge density

D = the dielectric constant

∇ = the Laplace operator

The average distribution of ions in the solution is given in relation to the potential by Boltzman's equation.

$$n_i = n_i^0 \exp(-Z_i e\psi/kT) \quad (2)$$

n_i = number of the ions i per cm^3 at the point where the potential is ψ

n_i^0 = its number in the bulk solution per cm^3

Z_i = its valency

R = Boltzmann constant

T = the absolute temperature

e = the electronic charge

The volume charge density, ρ , is given by the algebraic sum of the ionic charges per unit volume.

$$\rho = \sum Z_i e n_i \quad (3)$$

Combining equations (1), (2), and (3), the basic Poisson-Boltzman differential equation for the potential, ψ , is obtained.

$$\nabla^2\psi = -\frac{4\pi}{D} Z_i e n_i^0 (\exp(-Ze\psi/kT)) \quad (4)$$

For an infinitely large plane interface ∇^2 can be replaced by $\frac{d^2\psi}{dx^2}$, equation (4) then simplifies to

$$\frac{d^2\psi}{dx^2} = -\frac{4\pi}{D} Z_i e n_i^0 (\exp(-Ze\psi/kT)) \quad (5)$$

Assuming that a 1:1 symmetrical electrolyte surrounds the plates, and making use of trigonometrical identities (see El-Swaify (25)) equation (5) is further simplified to

$$\frac{d^2\psi}{dx^2} = \frac{8\pi Z e n}{D} \left(\sinh\left(\frac{Ze\psi}{kT}\right) \right) \quad (6)$$

For the general solution of the differential equation (6) see Overbeek (59), and El-Swaify (25). An approximate solution for equation (6) is valid for small surface potentials ($\psi \ll 25\text{mV}$ and $Ze\psi/kT \ll 1$). Using the first term only of the series expansion of $\sinh\left(\frac{Ze\psi}{kT}\right)$, equation (6) becomes

$$\frac{d^2\psi}{dx^2} = -\frac{8\pi Z^2 e^2 n^0}{DkT} \psi = -K^2 \psi \quad (7)$$

where $K^2 = \frac{8\pi Z^2 e^2 n^0}{DkT}$, and $1/K$ is often referred to as the effective

thickness of the double layer. Intergration of equation (7) using the boundary conditions $\psi = \psi_0$ when $x = 0$, yields

$$\psi = \psi_0 \exp(-Kx) \quad (8)$$

The equation indicates that the potential ψ decays exponentially with increasing distance from the surface.

The surface charge density, σ , of a colloid must be equal but opposite in sign, to the excess charge in the solution adjacent to the surface, in order to maintain electroneutrality of the total double layer. The expression for obtaining the surface charge density is

$$\sigma = \int_0^{\infty} \rho dx \quad (9)$$

By making use of the Poisson relation (equation (1)), and making appropriate substitutions (see Overbeek (59), and Elswaify (25)) the solution of equation (9) is obtained.

$$\sigma = \left(\frac{2n^0 D k T}{\pi} \right)^{1/2} \sinh \left(\frac{Z e \psi_0}{k T} \right) \quad (10)$$

where ψ_0 is the potential at the surface. For very small potentials, equation (10) simplifies to

$$\sigma = \left(\frac{2n^0 D k T}{\pi} \right)^{1/2} \frac{Z e \psi_0}{2 k T}$$

or

$$\sigma = \frac{D K}{4 \pi} \psi_0 \quad (11)$$

In this case the charge, σ , and the surface potential, ψ_0 , are proportional to each other; the distinct effect of the surrounding electrolytes on σ or ψ_0 is also shown.

From the condition of electroneutrality of the double-layer, the relationship between the surface charge, σ_s (which is obtained from equation (11)), and the charge in the diffuse or Gouy layer, σ_d , is

$$\sigma_s = -\sigma_d \quad (12)$$

3. The double-layer with specific adsorption

As indicated in the preceding section, the Gouy-Chapman theory of the double layer has some serious defects. Their theory treated the ions as point charges which can approach the surface within any distance however small it might be. This oversimplification results in a much larger differential capacity of the double layer than it actually is and abnormally large values of σ are thus predicted (19). Stern (1924) corrected the unrealistic elements in the Gouy-Chapman model by including specific interaction between the surface and the counter ions. Further improvement to the Stern theory was applied by Grahame (1947). Henceforth the discussions on the double layer will concern the Gouy-Chapman-Stern-Grahame (G.C.S.G.) model. The G.C.S.G. model advocates a compact layer with two planes of closest approach - the plane closest to the surface is called the inner Helmholtz plane (IHP) or the Stern layer, and is the locus of the centers of charge of the specifically adsorbed ions; the second plane located at a distance, δ , from the surface is the outer Helmholtz plane (OHP) and represents the plane of closest approach by the non-specifically adsorbed ions. In this treatment a molecular condenser is formed by the surface charge and the charge in the IHP. (For a critical evaluation of the models of the double layer see the paper by Bockris et al., 1963, ref. 13.)

The total potential drop ψ_0 is divided into a potential ψ_δ over the diffuse part of the double layer and $\psi_0 - \psi_\delta$ over the molecular condenser the potential drops linearly from a value ψ_0 at the surface to ψ_δ at the OHP.

The charge on the surface, σ_s , is equal to but opposite in sign to the sum of the charges in the molecular condenser, σ_m , and the charges in the diffuse part of the double layer, σ_d . Thus

$$\sigma_s = -(\sigma_m + \sigma_d) = -(\sigma_m^+ + \sigma_m^- + \sigma_d^+ + \sigma_d^-) \quad (13)$$

In the G.C.S.G. model, the diffuse part of the double layer is treated in the same way as the Gouy-Chapman diffuse double layer except for the fact it no longer extends to the surface but only to a defined distance, δ , away from it. Furthermore the reference potential is no longer ψ_0 (surface potential) but ψ_δ (the potential at OHP). For the compact part of the double layer (molecular condenser) the Stern treatment must be applied. However, although the structure of the compact double layer is fairly well understood from a qualitative point of view, the quantitative interpretation is still yet less satisfactory than for the diffuse layer. Nevertheless, the G.C.S.G. model still provides important interpretations (though more qualitative in nature) of the double layer of clay systems in which specific counter-ion adsorption often occurs. The obvious influence of ψ_δ on electrokinetic phenomena and especially on the stability of colloids will be discussed later. The G.C.S.G. model is shown in Fig. 1.

B. The Reversible Double Layer at the Oxide-Solution Interface

The double layer at the oxide-solution interface has important implications regarding the interpretation of the electrochemical properties of the oxidic soils of Hawaii or for that matter of oxidic soils in general. Studies of the reversible double layer on oxides as first used by Parks and de Bruyn (62) are based on acid-base titrations

Fig. 1. Schematic representation for a negative surface of the potential, ψ , and charge, σ , distribution in the double layer according to the G.C.S.G. model (from Breeuwsma, 1973). d = distance from the surface, C_0 = the electrolyte concentration at $\psi = \psi_0$.

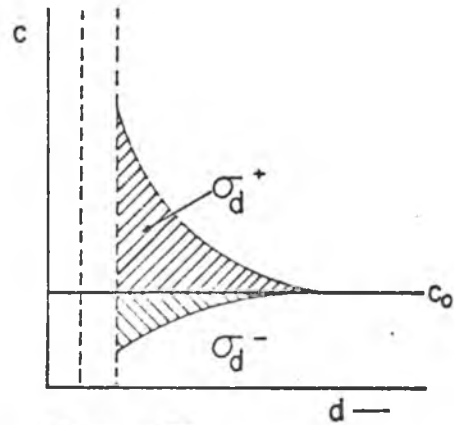
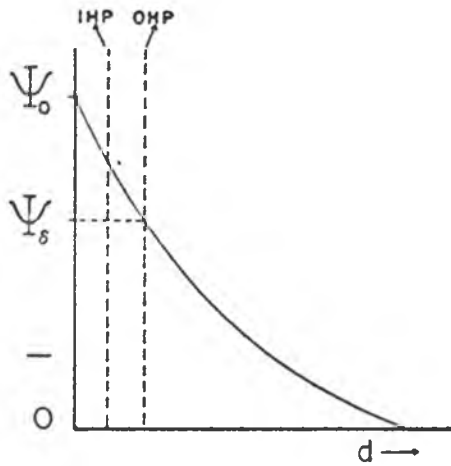

$$\sigma_s = -\sigma_d$$

NO SPECIFIC ADSORPTION

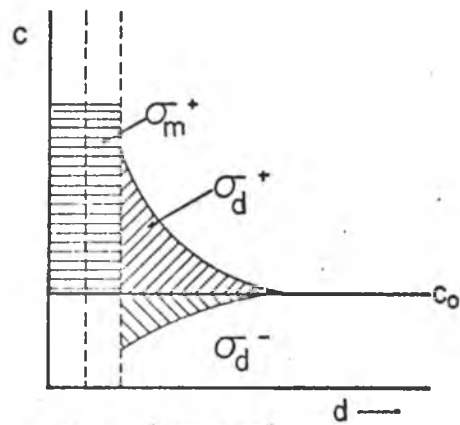
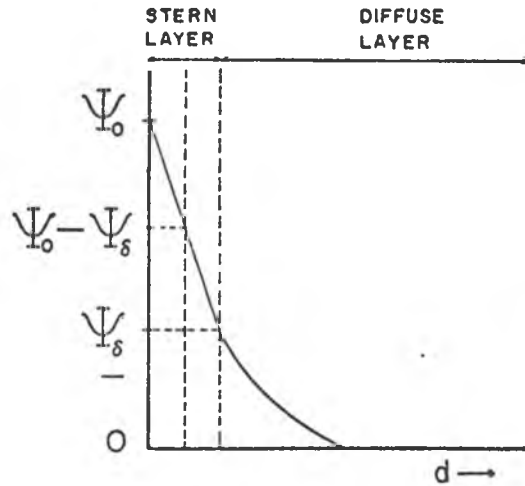

$$\sigma_s = -(\sigma_m \sigma_d)$$

$$|\sigma_s| > |\sigma_m|$$

SPECIFIC ADSORPTION OF CATIONS

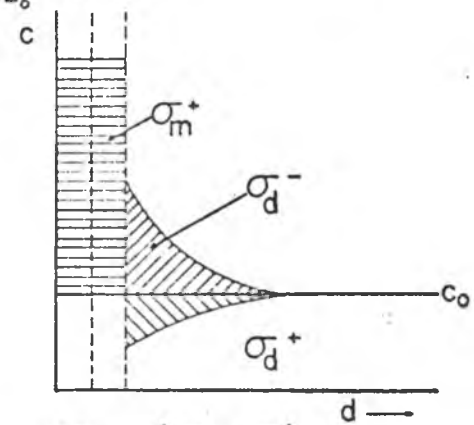
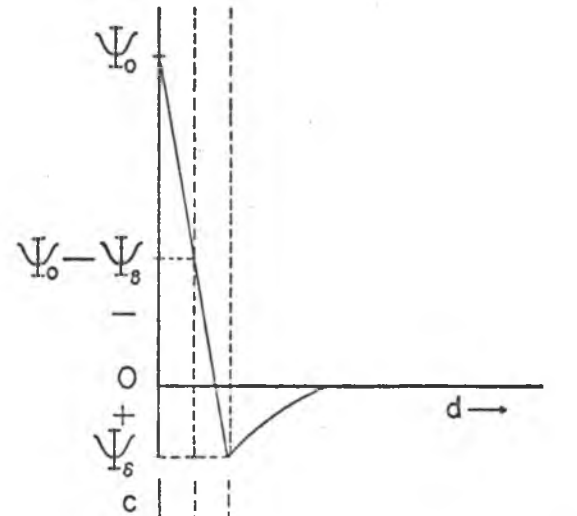

$$\sigma_s = -(\sigma_m \sigma_d)$$

$$|\sigma_s| < |\sigma_m|$$

SUPEREQUIVALENT ADSORPTION OF CATIONS

of oxides of known surface areas as a function of pH and ionic strength. The principle of using such a method is based on the potential-determining roles of H^+ and OH^- ions for oxides (62) much like the role of Ag^+ and I^- for the AgI system (59, 52). Qualitatively, the mechanism by which the surface charge is established is generally viewed either as an adsorption of H^+ and OH^- or as a dissociation of surface hydroxides. This mechanism may be represented schematically as in Fig. 2A.

1. The positive surface charge

The positive surface charges on oxides are acquired by adsorption of H^+ ions from solution, therefore the positive surface charge density, σ_s^+ , is expected to depend primarily on A_{H^+} (i.e. the activity of H^+ in solution) and not on the anion concentration directly. However, Ahmed and co-workers (2, 3, 4) have found that although the positive surface charge of oxides increases with decreasing pH, the variation in σ^+ with concentration depend strongly on the nature of the anion as well as the nature of the oxides. This variation in σ^+ is shown to be greater than the expected variation due to the effect of increased ionic strength on the charge density of the diffuse double layer and on A_{H^+} itself. They, therefore, proposed an additional mechanism which in addition to a proton-transfer process, advocates a basic dissociation of the surface hydroxyl groups and the subsequent replacement of the OH^- groups by the anions. Such a dissociation process in acid-base titrations results in more OH^- groups being liberated into solution resulting in an increase in the pH of the bulk solution; the apparent value of σ^+ will thus depend not only

Fig. 2. The process by which a surface charge is established on oxides. The metallic cations are denoted by M.

- A. The charging mechanism in the absence of specific adsorption (from Parks et al., 1962).
- B. The charging mechanism when anions, denoted by A, are specifically adsorbed at $\text{pH} < \text{ZPC}$ (from Ahmed, 1972).

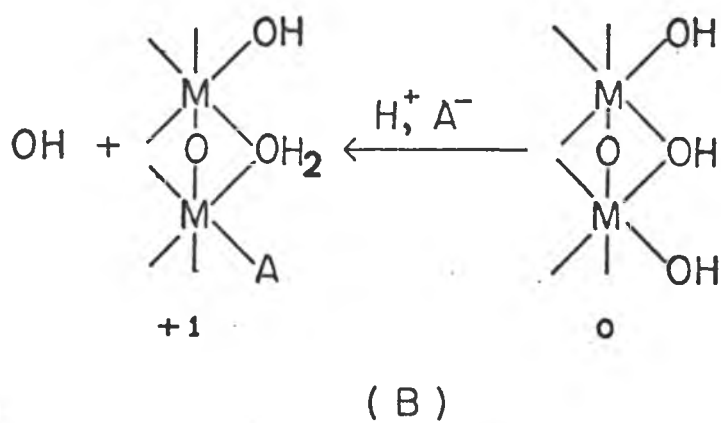
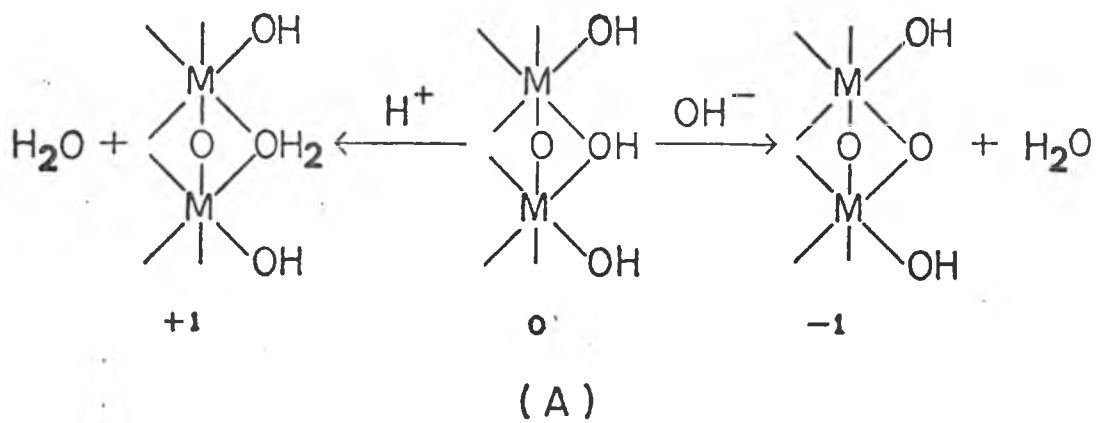

on the pH but also on the concentration as well as the nature of the anion. This mechanism may be looked upon as an attempt to describe specific interactions between the metal ions of the oxides and anions as shown schematically in Fig. 2B.

2. The zero point of charge (ZPC)

The ZPC of an oxide has been defined by Parks and de Bruyn (62) as the pH at which the surface excess of H^+ and OH^- is equal; in other words $\Gamma_{H^+} = \Gamma_{OH^-}$ where Γ_{H^+} and Γ_{OH^-} are the adsorption densities of H^+ and OH^- respectively at the ZPC. The ZPC is an important parameter for describing the double layer of free charges at the oxide surfaces. However, there still exists a great deal of controversy concerning not only the definition but also the significance of this parameter. Aside from the various experimental uncertainties (60, 61), the ZPC of oxides has been found to vary with temperature (10), surface hydration and heat treatment of the oxides (10, 67), and when specific interaction occurs between the oxide and counter ions (14, 41, 42).

3. The negative surface charge

In the absence of specific interactions between surface and counter ions, the negative surface charge results primarily from an acidic dissociation of the surface hydroxyl group (Fig. 2A), and increases with increasing pH and electrolyte concentration. An additional charging mechanism was proposed by Hingston and his co-workers (1967, 1968, 1972) to account for the additional surface charges developed when specific interaction between the surface and "anion acid" occur (Fig. 3). The proposed reaction mechanism indicates that specific adsorption of these anions renders the surface more negative

Fig. 3. Reactions at the oxide-solution interface when anions (H_2PO_4^-) are specifically adsorbed (from Hingston et al., 1967).

- (1) Neutralization of positive charges at $\text{pH} < \text{ZPC}$.
- (2) Ionization of a proton of adsorbed anion acid.
- (3) Enhancement of the tendency of the surface itself to acquire a negative charge.

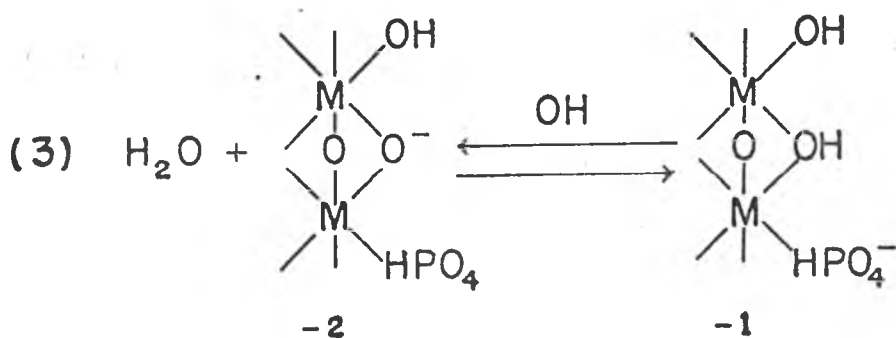
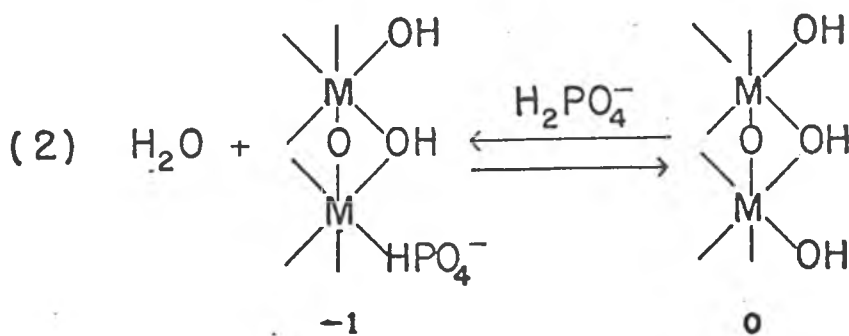
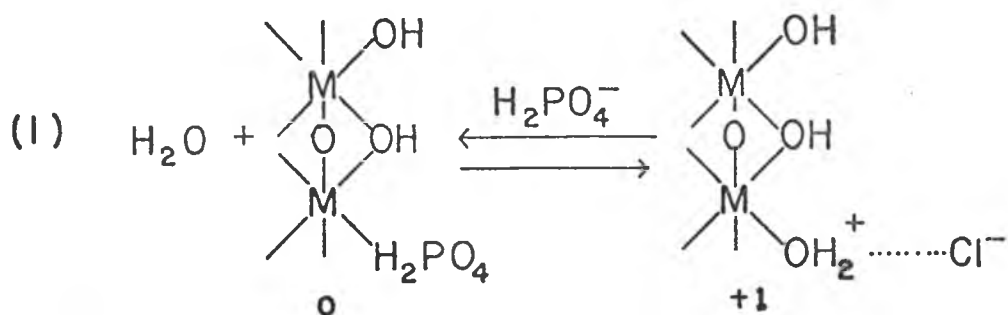

through displacement of a coordinated hydroxyl ion. However, the negative charge is developed only if the hydroxyl ion is retained by the surface through the formation of water. This displacement of a coordinated hydroxyl ion is termed a "ligand exchange." Furthermore, the anion acids (i.e. the anions of incompletely dissociated acids) may be adsorbed on a neutral or negative surface as long as they are able to dissociate at the surface to provide protons which react with the surface OH^- of neutral sites to form water. The net result of this reaction is that the ZPC of the oxide will be shifted to more acid values, and also the possibility that more than one zero point of charge could be detected. In contrast to the anion acids, the anions of completely dissociated acids (e.g. F^- or SO_4^{2-}) are incapable of being adsorbed to a neutral or negative surface; they are only adsorbed when the surface is positively charged. They may be specifically adsorbed by the surface, but, the ligand exchange in this instance neutralizes the positive sites only, until the surface reaches a new zero point of charge. The latter reaction mechanism is somewhat similar to that proposed by Ahmed (Fig. 2B) except for the fact that the mechanism proposed by Hingston and co-workers (40, 41, 42) is a neutralization reaction.

4. Potential and charge distribution at the oxide-solution interface

For reversible interfaces, the change in surface potential, ψ_0 , is given by a Nernst type relation (61, 62, 14). For the thermodynamic treatment, the surface structure at the ZPC, where σ is zero, is used as a reference point. Thus the change in surface potential,

ψ_o , of the oxide relative to the ZPC in the absence of specific adsorption of counter ions is (Ahmed 1972, Parks et al., 1962)

$$d\psi_o = \frac{RT}{F} d \ln \left(a_{H^+} / a_{H^+}(ZPC) \right) \quad (14)$$

or

$$d\psi_o = \frac{-RT}{F} d \ln \left(a_{OH^-} / a_{OH^-}(ZPC) \right) \quad (15)$$

where R = gas constant, F = the Faraday constant, T = absolute temperature, a_{H^+} , a_{OH^-} = activities of H^+ and OH^- respectively at the pH in question, and $a_{H^+}(ZPC)$, $a_{OH^-}(ZPC)$ = their activities at ZPC. Since a_{H^+} and a_{OH^-} are interrelated, it is sufficient to make use of equation (14) only. At a given pH, and a temperature of 25°C:

$$\psi_o = -0.059 (\text{pH} - \text{ZPC}) \quad (16)$$

For $\psi_o \ll 25\text{mV}$, a combination of equations (16) and (11) will yield the relationship between the surface charge, σ_s , and surface potential, ψ_o .

$$\sigma_s = \frac{-DK}{4\pi} \left(0.059 (\text{pH} - \text{ZPC}) \right) \quad (17)$$

Equation (17) shows that σ_s is positive, zero, or negative whenever the pH is less than, equal to, or greater than the ZPC. Expressed in another way, equation (17) indicates that the sign of σ depend solely on the activities of H^+ or OH^- in the bulk solution and not on the valency, Z, or concentration, n^o , of the counter ions, unless they affect the activities of H^+ or OH^- . For a given pH however, the valency and concentration of the counter ions do affect the magnitude of σ .

In most situations, surface potentials greater than 25 mV are often encountered. In such cases, equation (17) can not be used to calculate σ , the following expression must then be used.

$$\sigma_s = F (\Gamma_{H^+} - \Gamma_{OH^-}) \quad (18)$$

More often, σ_s is expressed in terms of me. per gram in soil science; then equation (18) can be modified, giving

$$\sigma_s = (\Gamma_{H^+} - \Gamma_{OH^-}) \text{ me/g} \quad (19)$$

where Γ_{H^+} , Γ_{OH^-} are the surface excesses of H^+ and OH^- per gram.

Further difficulties in the study of the double layer at the oxide-solution interface is encountered because of the fact that ψ_0 cannot be measured directly. Thus most data, as will also be the case in this study, are often presented in the form of (σ vs pH) curves. As for the theoretical interpretation of the double layer at the oxide-solution interface, the G.C.S.G. treatment must be applied.

C. Colloidal Stability and Flocculation Phenomena

1. Interaction between similar particles

In the previous section, consideration was given only to the double layer surrounding infinitely separated particles. In actual colloidal suspensions however, there are a great number of particles that interact with each other. This case is discussed quite extensively by Verwey and Overbeek (80) and Derjaguin and Landau (21). On the basis of the modern theory of stability, the interaction of colloidal particles is presumed to contain two components. One, the repulsive factor, finds its origin in the electrochemical double

layer. The other is the general van der Waals-London attraction. Verwey and Overbeek (80) have shown that the transition between a stable and a flocculated system can be represented by the total change in the interaction free energy (V_t) of the system of double layers. This interaction free energy is made up of the repulsive free energy (V_R) and the attractive free energy (V_A).

Energy of repulsion (V_R). When particles of like charges approach each other to such an extent that their diffuse double layers interpenetrate, repulsion between the particles will take place. The amount of work required to bring the particles from an infinitely large distance of separation to a defined distance is the repulsive energy, V_R . Verwey and Overbeek (80) have shown that when the interaction between two plane-parallel surfaces is small, this repulsive energy can be calculated from the approximate equation.

$$V_R = \frac{64nkT}{K} \gamma^2 \exp(-2Kd) \quad (20)$$

where d is the distance half-way between the plates and

$$\gamma = \frac{\exp(Ze\psi_0/2kT) - 1}{\exp(Ze\psi_0/2kT) + 1} \quad (21)$$

Inspection of equation (20) indicates that for small interactions, V_R decays exponentially and the rate of decay is determined solely by the quantity K . In general however, the repulsive energy may be expressed by the function

$$V_R = \frac{n}{K} \int(\psi_0, \psi_d) = \frac{K}{Z^2} \int(\psi_0, \psi_d) \quad (22)$$

in which ψ_d is the electrical potential half-way between the particles and the other symbols have their usual meaning. For a given value of

ψ_0 and ψ_d , the value of V_R will depend on the valency and concentration of the electrolyte. On the other hand for fixed values of K and Z , the value of V_R depends on ψ_0 (since for a given distance between the particles, ψ_d is a function of ψ_0).

Energy of attraction. The attractive energy, V_A , between particles is mainly due to the van der Waals-London attractive forces. The van der Waals attraction between atom pairs is additive; hence the total attraction between particles containing a very large number of atoms is equal to the sum of all the attractive forces between every atom of one particle and every atom of the other particle.

For the case of two interacting plates of thickness δ , at a distance $2d$ from each other, the expression for the attractive energy derived by Verwey and Overbeek (1948) is

$$V_A = -\frac{A}{48\pi} \left(\frac{1}{d^2} + \frac{1}{(d+\delta)^2} - \frac{2}{(d+\delta/2)^2} \right) \quad (23)$$

in which A is referred to as the van der Waals-London constant. For most practical cases, these authors considered the quantity A to have a magnitude in the neighborhood of 10^{-12} erg. They also provided some useful approximations for some special cases:

$$d \gg \delta, \quad V_A = -\frac{\delta^2 A}{32\pi d^4} \quad (24)$$

$$d \ll \delta, \quad V_A = -\frac{A}{48\pi d^2} \quad (25)$$

In most colloidal systems, the most interesting case is that for which the distance between particles is roughly of the same order of magnitude

as the double layer thickness. This situation is perhaps better represented by equation (24) (Verwey and Overbeek, 1948). It is also interesting to note that the attractive energy decays with the second negative power of the distance thus having a larger effective range than the attractive energy between two molecules ($V_A \propto 1/r^6$).

Total energy of interaction, V_t . The total energy of interaction between colloidal particles is found by summation of the repulsion and attraction energies at each particle distance. The resulting summation is then expressed in the form of a net interaction curve as a function of particle separation, see Fig. 4. Since the net interaction curve is completely determined by the quantities V_R and V_A , a critical examination of these quantities is necessary.

For a system built up of given substances, the van der Waals-London constant, A , is a fixed quantity, that is, by changing the electrolyte concentration it will not be significantly altered. Furthermore, it was shown in the previous sections that, V_A decreases quadratically with increasing particle separation while V_R on the other hand decreases exponentially. Since an exponentially decreasing function goes to zero more rapidly than a function decreasing with a negative power, and since the curve for V_R starts with a finite value for zero distance, it is expected on the basis of the approximate equation (25) that the attractive energy V_A will always be larger than V_R for two cases: for very large and very small distances. In the intermediate distances, there are two possibilities. If V_R is sufficiently large in comparison to V_A , then the total interaction energy (V_t) curve will show a maximum over a certain region of the distance and may reach beyond the horizontal axis as shown in

Fig. 4. Schematic representation of the net interaction energy, V_t , as a function of particle separation, d (adapted from van Olphen, 1963).

- (A) The effect of increasing ψ at a given value of K , or, decreasing K at a given value of ψ .
- (B) The effect when the magnitude of K is increased at a fixed value of ψ , or, decreasing ψ for a given value of K .

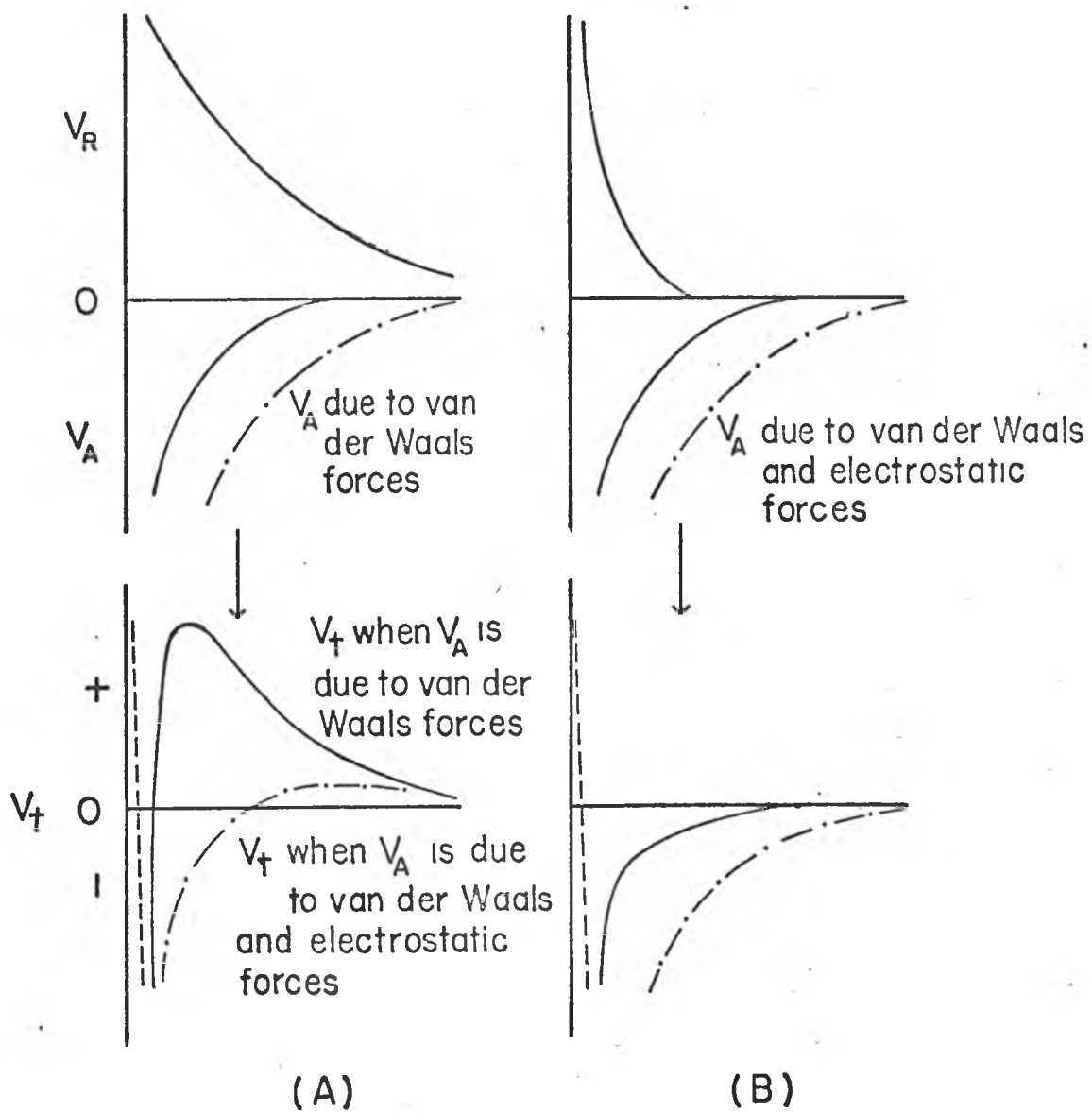

Fig. 4A. Beyond this region the curve will again reach negative values. The maximum may be thought of as an energy "barrier" which prevents particles from coagulating together. If, on the other hand, V_A is large compared to V_R , the total interaction energy is always negative or zero. These two types of total interaction energy curves are illustrated in Fig. 4B.

In applying these total energy curves to the problem of the stability of colloids, it may be assumed that the curves of type (a) ($V_R > V_A$) represents stable systems, and type (b) ($V_A > V_R$), the flocculated systems. Accordingly a study of stability conditions of a colloidal system involves knowledge of values for the parameters of the system at which the transition between case (a) and (b) exists. There are actually two ways of transferring energy curves of type (a) into energy curves of type (b): the first is by reducing the surface potential, the second, by increasing the quantity K . Relationships between these parameters and the energy of interaction will be discussed in more detail in a following section.

2. Interaction of double layers on the basis of Stern's theory

The interaction between two Stern double layer is primarily due to the interpenetration of their diffuse "Gouy" layers, hence the considerations and equations given earlier can still be applied. There are however, two important differences. The potential at the OHP, ψ_δ , rather than the surface potential ψ_0 , determines the magnitude of the repulsive energy, V_R . Furthermore, the effective distance between particles is measured from their OHP. The consequences thereof are twofold:

1. ψ_δ is a function of ionic concentration as well as ionic size. It is further affected when specific interaction occurs between surface and ions.

2. The potential ψ_δ is always smaller than the surface potential ψ_0 .

In the discussions developed in the foregoing sections, it was shown that flocculation can be understood entirely in terms of the contraction of the diffuse layer only. The Stern correction however, postulates that besides compressing the diffuse layer, the addition of electrolytes lowers the diffuse layer potential, ψ_δ . In flocculation studies it has been found that flocculation values (the amount of electrolyte required to reduce the stability of a sol to a certain level) are smaller for larger and for specifically adsorbed ions (70, 80). This is what might be expected on the basis of Stern's theory, for larger ions reduce the capacity in the Stern layer thus causing a large drop of the potential in this layer. As a result the potential in the diffuse layer is smaller than with small ions. In the same way, specifically adsorbed ions cause a large part of the total double layer potential to be confined to the Stern layer leaving only a very small part of ψ_0 as effective repulsive potential. Thus the Stern theory though less understood quantitatively, is able to provide a better understanding of the experimental findings regarding the stability of hydrophobic colloids.

3. Interaction between dissimilar particles

When a colloidal dispersion contain particles of more than one kind, it is likely that the different particles have different

charge characteristics. When the charges are opposite in sign, mutual flocculation due to interaction of opposite charges will take place. Extension of the Derjaguin-Landau-Verwey-Overbeek (DLVO) theory to the problem of mutual flocculation of dissimilar colloids have been attempted by several authors (e.g. Derjaguin, 1954, Hogg et al., 1966, Pugh et al., 1970). Full quantitative treatment of the phenomenon is difficult due to the cumbersome computations involved.

In his development of the theory of heterocoagulation, interaction and adhesion of dissimilar particles in electrolyte solutions, Derjaguin (1954) has shown (see Fig. 5) that when particle charges have the same sign, but the potentials of the individual particles are different, the magnitude of the energy of repulsion is determined by the particle with lower potential. The major parameters of the theory by Hogg, Healy, and Fuerstenau (1966) include also the double layer potential of each colloid, ionic strength, particle size, and concentration. It applies to the case when the surface potentials and charge characteristics of the particles are similarly affected by pH and electrolyte concentration.

The latter theory predicts that in a binary system containing particles of equal size and concentration, but each particle having different ZPC the whole pH range between the two ZPC values is a flocculation region. When one component is present in excess of the other, the system will consist of two phases over the range between the two ZPC's - a coagulated phase made up of a mixture of the two components and a dispersed phase containing only the component originally present in excess.

Fig. 5. Schematic representation of the repulsive energy, V_R , for a given value of K when the potential of the particles is varied.

(A) $\psi_1 = \psi_2$ (B) $\psi_1 \sim 3\psi_2$ (C) $\psi_1 \sim 4\psi_2$

(D) $\psi_1 \sim 7\psi_2$ (from Sonntag et al., 1972).

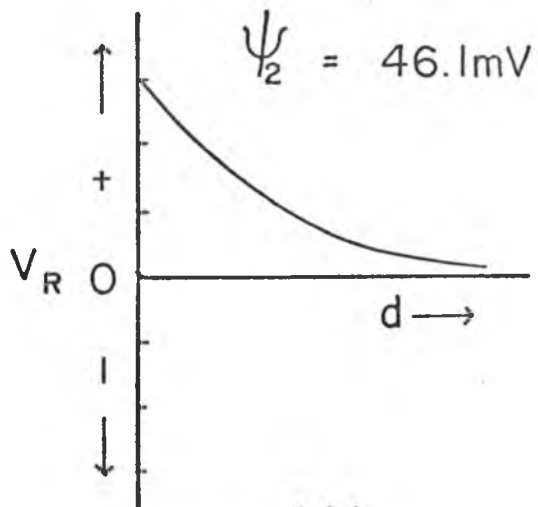

(A)

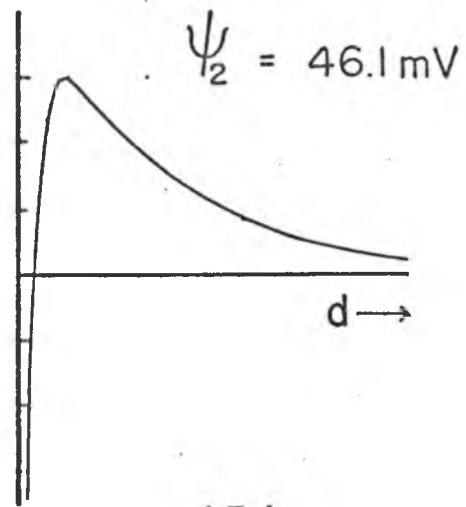

(B)

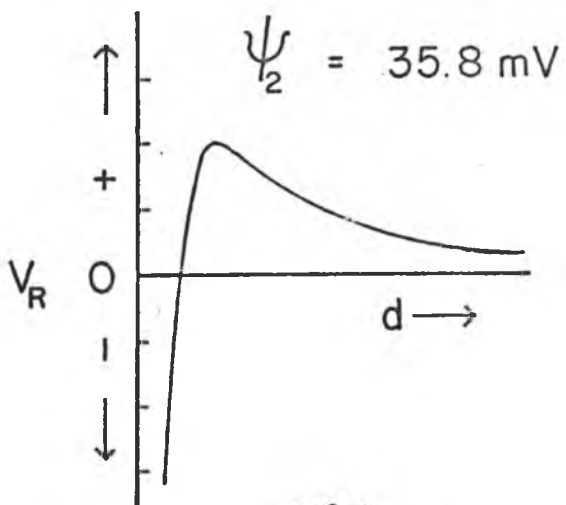

(C)

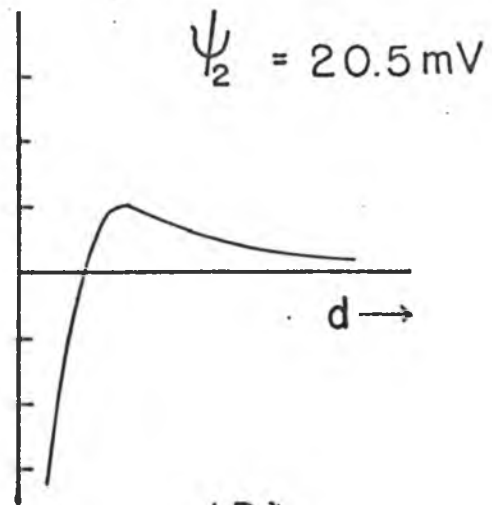

(D)

Princen and co-workers (1964) on the other hand, in working with ZnO and TiO₂ described the phenomenon of mutual flocculation entirely from particle size considerations without including the concept of equality of opposite charges on the interacting colloids. The theory predicts the extent of flocculation from geometric considerations by taking into account the ratio of the sizes and number of each particles within the system.

It is obvious from the above discussions that interaction between dissimilar particles is governed by the same laws as that between similar particles, that is, it is caused by the interaction between the electrostatic energy of repulsion due to interpenetration of double layers and the attractive energy due to attractive forces. In systems containing oppositely charged colloids, attraction other than that due to the van der Waals-London forces also arises, due to mutual electrostatic attraction of oppositely charged double layers, which will in effect enhance the attractive forces (Fig. 4). Since the electrostatic energy is proportional to $1/d$, it is noted in the figure that its range far exceeds the van der Waal forces.

A full quantitative explanation of mutual flocculation is possible when the double layer potential and charge characteristics, size and concentration of each colloid in the system, and electrolyte concentration is known. The above requirements are seldom if ever, met in real soil systems, nevertheless, the DLVO theory as modified by Derjaguin (1954) and Hogg *et al.* (1966) can be used either conceptually in interpreting experimental results or qualitatively for predictive purposes.

D. The Electrochemical Properties of Soil Colloids

On the basis of electrochemical behavior, van Olphen (78)

classified colloids into:

- a. Colloids with constant surface charge
- b. Colloids with constant surface potential.

Recently this scheme of classification was applied to soil colloids by El-Swaify (27), Van Raij and Peech (79) and Keng and Uehara (47). However, since soil colloids do not generally behave strictly either as type (a) colloids or type (b) colloids, classifying them according to the above scheme implies only the major source of the double layer at the particle surface.

1. Colloids with constant surface charge

If the surface charge of the particle originates from lattice sources or imperfections, and thus remains constant regardless of solution composition, it follows from the theory of the double layer (equation (11)) that the surface potential ψ_0 must decrease with increasing electrolyte concentration. The effect of electrolyte concentrations on the surface potential and counter ion distributions of type (a) colloids is shown schematically in Fig. (6).

The soil colloids which best exhibit this behavior are the layered silicates belonging to the montmorillonite or smectite group, the micaceous or illite group, and vermiculite. These minerals nearly always exhibit permanent net negative charges as a result of isomorphous substitution of cations in the tetrahedral or octahedral positions. They can also carry an electric charge as a result of broken bonds at the edges of the alumina and silica units. These

charges are pH dependent, and the double layer that develops at these edges is best described as in the case of type (b) colloids. However, since the contribution of this source to the total charge is relatively small the assumption that the above layered silicates carry permanent negative charges is still reasonably accurate.

2. Colloids with constant surface potential

If the surface potential of the particle is determined by the concentration of the so-called "potential determining ions" (PDI), the magnitude of this potential is unaffected by the addition of indifferent delectrolytes as long as the activity of the PDI is not affected by the presence of the electrolyte. Computations based on the double layer theory (Equation (11)) shows that the surface charge, σ , increases with increasing electrolyte concentration, when the surface potential, ψ_0 , remains constant (Fig. 6).

The soil colloids which best exhibit this behavior are the oxides and hydrous oxides of aluminum, iron, manganese, titanium, and silicon. These colloids acquire charges due to the adsorption of the potential determining ions (PDI) H^+ and OH^- ; the magnitude and sign of these charges, hence the surface potential also, depends on the activities of H^+ and OH^- in solution. The double layer which is developed as a result of this charge formation mechanism was already discussed in section B.

Organic colloids as well as the aforementioned oxides, are amphoteric in nature. In media of low pH they act as proton acceptors resulting in their being positively charged. Conversely, in media of high pH they act as proton donors, thus acquiring negative charges.

Fig. 6. Electric potential, ψ , and charge, σ , distribution in the diffuse layer at two electrolyte concentrations (from van Olphen, 1963).

- A₁ Potential distribution for constant surface potential colloids.
- B₁ Potential distribution for constant surface charge colloids.
- A₂ Charge distribution for constant surface potential colloids.
- B₂ Charge distribution for constant surface charge colloids.

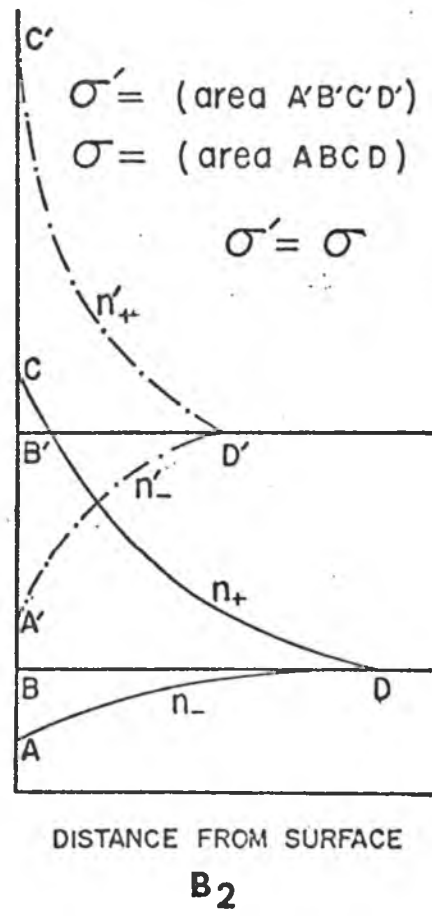
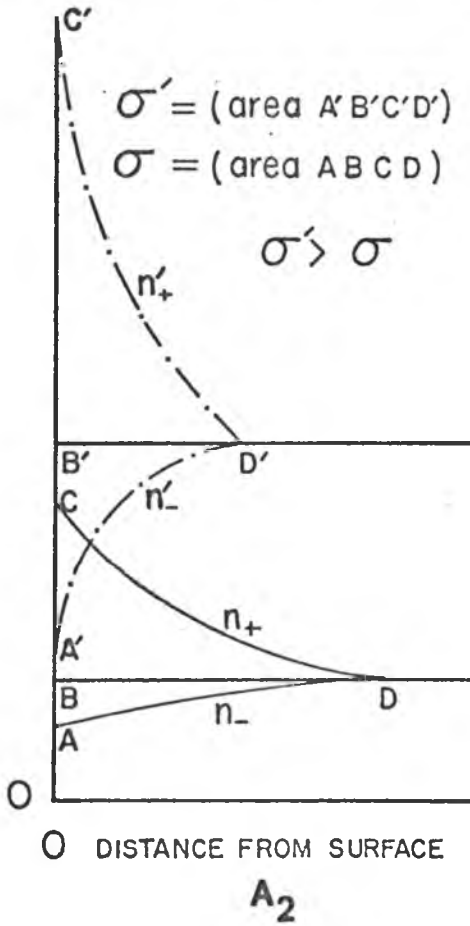
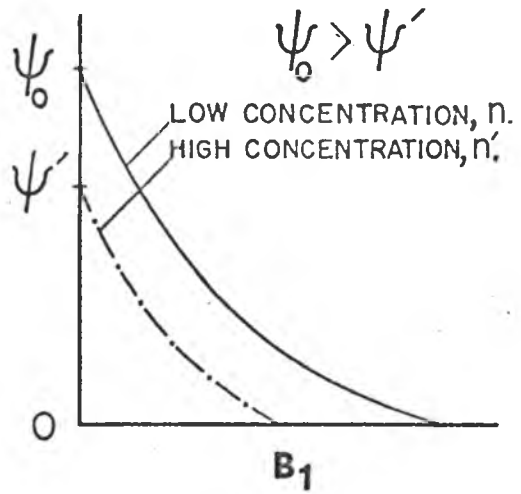
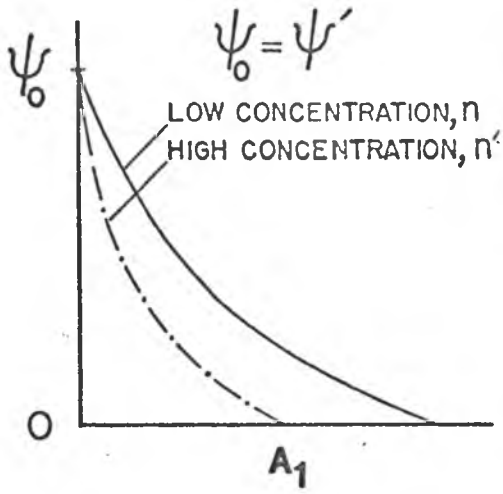

Similar mechanisms of charge formation are presumed to operate also in amorphous alumino-silicates (allophane) (81). Because the charges acquired by this second group of colloids are highly sensitive to the pH of the media, the reversible double layer at the oxide-solution interface may provide a reasonable interpretation of their electrochemical behavior.

Broken bonds at the edges of the crystals have been assumed to be the major source of charge of kaolinite and halloysite. Charges developed by this mechanism are highly dependent on the chemical properties of the environment. The work of Schofield and Samson (69) show that under acidic conditions kaolinite can acquire positive charges through adsorption of H^+ from solution, and negative charges under alkaline conditions through the dissociation of the exposed hydroxyl groups at the edges. The double layer formed as a result of these pH dependent charges may therefore be described in the same way as the surfaces of simpler oxides. Reported ZPC's of kaolinite (61) range between pH 3.5 to approximately 5.

Permanent negative charges due to substitutions in the tetrahedral and octahedral positions also occur in kaolinite (66). It is possible also that similar substitutions also occur in halloysite since Wada and his co-workers (81) found no appreciable change in CEC in the pH range between 4 and 7. The resulting double layer on this clay therefore, is best described by that of type (a) colloids.

E. Applicability of Concepts to Soils

A natural soil is a composite of many kinds of colloids and the relative effects of their interactions on the physical properties of

any given soil is frequently difficult to predict accurately. The problem is made somewhat less complex by assuming that the net behavior of a particular soil is determined by the dominant colloids in it. Thus for a soil which contain large amounts of oxides and hydrous oxides of Al, Fe, and Mn, in relation to the silicate clay minerals, it is possible to predict with reasonable accuracy the effect of their interactions on structure when information on the electrochemical properties of the respective colloids is available.

The highly favorable structure of oxidic soils is generally associated with the presence of sesquioxides (Lutz, 1936; Chesters et al., 1957) but the way in which they contribute to particle bonding is not well understood. Lutz (1936) first suggested a dual role for iron (which may be extended to sesquioxides in general) in bonding. The first is through physical cementation of particles into larger masses. Evidence of physical cementation was presented by Jones and Uehara (1973) when they showed the existence of amorphous gelatinous-like coatings on mineral surfaces binding particles together. The second role is through mutual flocculation of the oppositely charged oxides and other soil constituents. It is the latter role with which the present study is concerned.

Investigations on the phenomenon of interactions between oxides and other soil constituents were quite often inconclusive and sometimes contradictory (Sumner, 1963; Desphande et al., 1968; Tweneboah et al., 1967). The discrepancy in the results have been attributed to the fact that the "selective" dissolution methods employed in these studies were not entirely selective for the particular constituent

under study (El-Swaify, 1975). A second approach to the investigation of the effects of sesquioxides on physical properties involves the addition of Al- or Fe- hydroxides which had been prepared separately, to clays (Blackmore, 1973) or by directly precipitating the hydroxides on to clays (El-Swaify et al., 1975). This method has one main advantage in that the effects of different oxides on soil properties is easily separable. Using this approach, El-Swaify (1975) has shown through stability diagrams of hydroxide-treated clays that the phenomenon of mutual flocculation between colloids which have oppositely charged double layers, is directly related to the charge balance in the system.

A simplified theory was presented for predicting the relative effects of interactions between oxides and soil clays, on the net behavior of oxidic soils. It is assumed that the non-amphoteric colloids (silicate clay minerals, although it is not always true for kaolinite or halloysite) carry only permanent negative charges, σ_c , while the amphoteric colloids (sesquioxides, amorphous material, and organic matter) carry variable charges, σ_v . The charge balance or net charge, σ_n , is the algebraic sum of σ_c and σ_v . The permanent charge can be derived from the Gouy treatment of a single double layer (equation (10) or (11)) and the variable charge from the combined Gouy-Nernst equation (equation (17)). Thus, when the pH of the soil is varied, it is possible to approximate the newly developed electrostatic energy of repulsion from the change in the net charge (for more detail, see El-Swaify, 1975, Part II).

This theory predicted a linear relationship between the repulsive energy and pH, and is particularly applicable in the pH range in which the transition between a fully flocculated and fully stable system occur. As discussed previously (Sect. C.3.), a full quantitative explanation of the phenomenon of mutual flocculation requires precise knowledge of the double layer potential and charge characteristics, as well as the size and concentration of each colloid in the system; a requirement which is almost impossible to fulfill in real soil systems. There is no technique yet available which will enable one to measure the double layer potentials of soil colloids, nor the size and concentration of each colloid in the system. Techniques for measuring the charge characteristics of soils are however available; therefore, the approach proposed by El-Swify (29) seems to be a reasonable compromise regarding the application of the theory of stability to soil systems.

MATERIALS AND METHODS

A. Description of Soils

Three Hawaiian soils representing tropical Inceptisols, Oxisols, and Ultisols were selected on the basis of their representing soil orders that are widespread throughout Hawaii and the tropics. Furthermore a study of the field erodibility of these soils by rainfall simulation with a rainulator was being conducted concurrently with this study and it is anticipated that some relationships could be established between the electrochemical properties of soil colloids and soil performance in the field.

The following descriptions of the soils were obtained from the "Soil Survey Report of the Islands of Kauai, Oahu, Maui, Molokai, and Lanai," and "Soil Survey Report of Island of Hawaii," USDA Soil Conservation Service and University of Hawaii Agricultural Experiment Station Report, 1972 and 1973 respectively. Whenever possible, soil descriptions provided by S.C.S. personnel for the actual erodibility test site from which the samples were collected is used.

1. Hilo silty clay - Inceptisol

Location: Island of Hawaii

Classification: Typic Hydrandept, thixotropic isohyperthemic
(Hydrol Humic Latosol)

Horizon: Plow layer, 0 - 18 inches

Parent material: Volcanic ash

Vegetation: Originally ohia - tree and fern vegetation,
now cleared and in sugarcane

Climate: Average annual rainfall is 175 inches. The mean annual temperature is 72°F (22.2°C)

Topography: Rolling low windward mountain slopes, 0 - 10% slopes

Drainage: Well drained, rapid permeability

Description*: (Ap - 0 to 12 inches), dark brown (10 YR 3/3 to 7.5 YR 3/2, moist) silty clay loam containing sand and gravel-size aggregates in the upper 0 to 1 inch layer; below this layer, the structure is moderate medium and fine subangular blocky; firm, slightly sticky and plastic.

The soil dehydrates "irreversibly" to sand and gravel size aggregates.

*Description provided by O. F. Bailey, Hawaii State Soil Scientist, Soil Conservation Service, U.S.D.A. for Rainulator sites 34 and 35.

2. Molokai silty clay - Oxisol

Location: Island of Oahu

Classification: Typic Torrox, clayey, Kaolinitic, isohyperthermic (Low Humic Latosol)

Horizon: Plow layer, 0 to 12 inches

Parent material: Basic igneous rock or alluvium

Vegetation: Sugarcane and pineapple

Climate: Average annual rainfall is 25 inches
The mean annual temperature is 72°F (22.2°C)

Topography: Gentle slope, 0 to 4%

Drainage: Well drained, runoff is slow to medium, medium, moderate permeability

Description*: (0 to 8 inches) - Dusky red (2.5 YR 3/2) silty clay; weak very fine granular structure; friable sticky and plastic. (8 to 16 inches) - Mixture of dusky red (2.5 YR 3/2) and dark reddish brown (2.5 YR 3/4) silty clay loam; weak medium subangular blocky structure; friable, sticky and plastic.

*Description provided by S. Nakamura, Soil Conservation Service, U.S.D.A., on the Rainulator site 5 and 6.

3. Waikane silty clay* - Ultisol

Location: Island of Oahu. Along Kamehameha Highway about one mile north of Waihole School. The site is the northwest corner of Kamiya Farm

Classification: Humoxic Tropohumult, clayey, kaolinitic, isohyperthermic

Horizon: Plow layer, 0 to 10 inches

Parent material: Old alluvium

Vegetation: California grass, Hilograss, Java plum

Climate: Average annual rainfall is 75 inches, with mean annual temperature of 71°F (21.7°C).

Topography: The soil is found at elevations from 40 ft. to 1000 ft. above sea level. The samples collected for this study was located at an elevation of 40 ft., with a 12% slope.

Drainage: Well drained, runoff is slow to medium, permeability is moderately rapid

Description: (0 to 9 inches) - Dark brown (7.5 YR 3/2) silty clay; cloddy and weak very hard, firm, very sticky and plastic.

*Descriptions of soil by S. Nakamura, S.C.S., on Rainulator test sites 24 and 25.

B. Experimental Methods

1. Characterization of samples

Field-soil pH. To 20 g (oven dry weight basis) of field soil which had been passed through a 2 mm sieve were added distilled water such that the soil: H₂O ratio was 1:1. After one-hour equilibration, the pH was measured on an Orion Research Ionalyzer, Model 801 digital pH meter. Similar procedures were followed for measuring pH in 1N KCl; the soil:KCl ratio was also 1:1.

Organic carbon. The organic carbon content of the respective soils was determined using the Walkley-Black method (C. A. Black, 1965, pp. 1372).

Mineralogy. X-ray diffraction patterns for each soil were obtained using a Philips Norelco X-ray diffractometer, with Cu K α radiation ($\lambda = 1.5418 \text{ \AA}$). Total elemental analysis was determined by Dr. R. C. Jones with the X-ray fluorescence Quantometer.

2. Preparation of soil materials for surface charge and colloidal stability measurements

In order to avoid "irreversible" changes in the nature of the charge sites, harsh chemical treatments such as acid washings were avoided. The soil samples were instead, equilibrated with N KCl by repeatedly washing in Buchner funnels. Because these soils contain relatively large quantities of sulfate, the washing procedure was continued until the test for sulfate (using BaCl_2 to precipitate SO_4^{-2} as BaSO_4) was negative, or until the amount extracted was negligible. Excess KCl was removed by repeated washing with deionized water until the electrical conductivity of the leachate was about 0.1 mmhos/cm which corresponds to approximately 1 me/l of dissolved solids in the leachate. A stock suspension was then prepared of the silt size and smaller fractions in deionized water after ultrasonic dispersion and passing through a 44 μm sieve. Determination of the clay concentrations of the stock suspensions was carried out by gravimetric methods.

3. Supporting electrolytes

All solutions were prepared in deionized water which had been distilled in a Barnstead laboratory unit and then passed through a mixed-bed deionizing column. The supporting electrolytes were:

- (a) 100% KCl ----- at concentrations of 0.001M, 0.01M, 0.1M, and 1.0M
- (b) 90% KCl + 10% CaCl_2 -- at concentrations of
- 0.001M (0.0009M KCl + 0.0001M CaCl_2)
- 0.01M (0.009M KCl + 0.001M CaCl_2)
- 0.1M (0.09M KCl + 0.01M CaCl_2)
- 1.0M (0.9M KCl + 0.1M CaCl_2)

(c) 90% KCl + 10% K₂SO₄---the concentrations, and the ratio of KCl:K₂SO₄ was the same as in (b)

(d) 90% KCl + 10% CaSO₄---because of solubility problems only two concentrations were prepared. They were:

0.001M (0.0009M KCl + 0.0001M CaSO₄)

0.01M (0.009M KCl + 0.001M CaSO₄)

4. Surface charge measurements - the potentiometric method

The procedure used followed closely that described by Parks and de Bruyn (1962), Atkinson et al. (1967), and El-Swaify and Sayegh (1975). Samples containing approximately 1 g of <50 μm soil fractions were suspended in 100 ml of the appropriate supporting electrolyte, the concentrations of which were discussed in section B.3. The soil was allowed to equilibrate overnight with the supporting electrolyte in a polyethylene container tightly closed with a screw cap before titration was begun. Titration data were obtained using the Orion Research Ionalyzer, Model 801 digital pH meter with Beckman type 42 glass and frit junction calomel electrodes. Mixing was provided by means of a magnetic stirrer using a Teflon coated bar. Equilibration periods before pH values were recorded, were determined in a preliminary experiment and varied depending on the type of supporting electrolyte. The equilibration periods were 45 minutes for pure KCl and (KCl + CaCl₂) systems, and 75 minutes for the (KCl + K₂SO₄) and (KCl + CaSO₄) systems.

The electrodes were immersed in the suspension only during the last 10 minutes of the equilibration period; during this time

interval, wet, CO₂-free N₂ gas was continuously bubbled through the suspension. In the remaining time, the suspension was tightly sealed in the container. One of the samples was titrated with 0.1N HCl to pH 2.5 or 3, and a second sample with 0.1N KOH to pH 11. Thus, each complete titration curve was the result of titrating two different samples. Identical blanks were prepared containing the same constituents but without the soil and subjected to identical titration procedures. The adsorption of the potential determining ions (H⁺ and OH⁻) was calculated from the difference in the amount of H⁺ (on the left of the intersection point of the test suspension and blank titration curves) and OH⁻ (on the right of the intersection point of the same curves) necessary to produce the same change in pH of the dispersion and of the blank. Assuming that H⁺ or OH⁻ adsorption represents the positive or negative charges acquired by the surface (Γ⁺ or Γ⁻ respectively), net charge curves were subsequently plotted as a function of pH.

5. Colloidal stability measurements

Suitable aliquots were taken from the stock suspensions prepared in section B.2., and made to volume such that the final concentration was one hundredth of the original. The latter served as stock suspension for colloidal stability measurements. Aliquots containing 10 ml of the stock suspension were added to a series of 25 x 150 mm culture tubes with screw cap. To each tube was added distilled water or KCl, the amount required depending on the final electrolyte concentration desired. HCl or KOH was added to each tube so that a pH range between 3 and 11 could be attained. The final

volume of suspension in each tube was 50 ml. After allowing for a 7-hour sedimentation period, a 25 ml aliquot was taken from the top 10 cm of suspension for turbidity measurement due to $<2 \mu\text{m}$ particles.

Turbidity of the samples was determined on a Hach laboratory turbidimeter, Model 2100, which had been calibrated in Jackson Turbidity Units (JTU), the standard unit of measurement in the water treatment industry. From current experience, the clay concentrations corresponding to any given JTU unit vary depending on soil coloration. For the Molokai soil (reddish brown in color) the clay concentrations corresponding to 50, 100, 150, and 200 JTU, were 0.0025%, 0.005%, 0.01%, and 0.02% respectively. A sample was judged to be completely flocculated when its turbidity was the same as for the blank (distilled water, or distilled water plus the appropriate electrolyte).

6. Particle - size analysis

Soil preparation and dispersion. Each of the soils was passed through a 2 mm sieve for particle-size analysis, without any pre-treatment being applied. Neither was an attempt made to remove soluble salts or organic matter. A series of samples each weighing 20 g (oven dry weight basis) were prepared. To each sample were added appropriate amounts of 1N HCl or 1N NaOH so that pH values ranging from 3 to 11 could be obtained, and, distilled water to obtain a solid:liquid ratio of 1:3 for the mixing process. Particle separation was achieved by shearing action using a Spex mixer-mill, without grinding. Each sample was shaken for 20 minutes, transferred to a 1000 ml sedimentation cylinder and made to volume with distilled

water. The suspensions were thoroughly mixed with a stainless steel plunger and then allowed to stand for the required time. The sedimentation intervals for measurements at 20 cm depth were 16 hours for particles $<2 \mu\text{m}$, and 80 seconds for those $<50 \mu\text{m}$ in diameter.

Sedimentation analysis with the plummet balance. The plummet balance is a specific gravity balance which enables one to measure the density of the suspension at a predetermined depth and time. It is designed on the same principle as the Edelfsen and Cole balance (Edelfsen et al., 1936), but it is so designed that adjusting for depth of immersion of the plummet is a more rapid process. The present instrument is a modified version from the one described by Marshall (1956), and was manufactured locally for the Department of Agronomy and Soil Science by the Hawaii Institute of Geophysics machine shop. The plummet is permanently attached to the balance and the pointer is locked in place by a sliding lock which can be moved out to free the pointer when the desired depth of sampling is reached. Final readjustment to attain the exact plummet depth requires only a few seconds.

The instrument was calibrated to read the direct percentage of soil in suspension on a scale divided into percentage units from 0 to 100, when the total initial concentration of the suspension is 2% (20 g soil/liter). The density of the suspension was measured by lowering the plummet into the suspension to a depth of 20 cm. The pointer was released from the locked position and the reading taken when the pointer became steady; this was usually accomplished within 20 seconds. Rapidity of reading was found to be critical only when

particles $>2 \mu\text{m}$ were still in suspension because errors could result from sediments collecting on top of the plummet.

After the density measurements on the plummet balance were completed, the suspensions were passed through a $50 \mu\text{m}$ sieve; the material which passed through the sieve was collected in 1000 ml beakers and the pH of the suspension measured. The materials collected on the sieve ($>50 \mu\text{m}$ in diameter) were transferred to tared aluminum moisture cans and dried to constant weight, then cooled in a desiccator before weighing. The per cent particles 2 - $50 \mu\text{m}$ as determined with the plummet balance was checked with the amount obtained from the difference between the original weight (20 gm = 100%) and the $<2 \mu\text{m}$ plus the $>50 \mu\text{m}$ fractions.

RESULTS AND DISCUSSION

A. Characterization of Soil Samples

Tables 1A to 1C show the important chemical and mineralogical properties of the three soils. The organic carbon content (Table 1A) indicate a relatively high organic matter content in the Hilo compared to the Waikane and Molokai soils. The masking effect of organic matter on positive charges (Hussain et al., 1970) and the subsequent lowering of the ZPC to lower pH values (Keng, 1974; Van Raij et al., 1972) was therefore expected to be greater in the Hilo than the Waikane or Molokai soils. On the basis of the total chemical analysis (Table 1B), and X-ray diffractograms, a quantitative estimate of the major minerals for each soil is presented in Table 1C. It is noticed that the Hilo soil consisted almost entirely of amphoteric colloids, while the Waikane and Molokai soils on the other hand contained large amounts of 1:1 silicate clay minerals. The relative effects of the interactions between the major colloidal constituents on the charge characteristics and consequently on colloidal and structural stability of these soils will be discussed throughout the following sections. The ΔpH can take on positive, zero, or negative values corresponding to the sign of the net charge on the colloids, thus under normal field conditions, the Hilo as opposed to the Waikane and Molokai soils possessed net positive charges (Table 1A). These observations are readily explained on the basis of their mineralogical composition (Table 1C), and, as will be discussed later, the charge characteristics of the major constituents.

Table 1A. Important soil properties--Characteristics
of original soil samples

Soil	Hilo	Waikane	Molokai
Depth (inches)	0 - 18	0 - 10	0 - 12
Moisture content (%)	178.30	40.20	4.60
Organic carbon (%)	7.85	2.04	1.79
pH _{H₂O}	5.70	5.03	6.08
pH _{KCl}	5.90	4.75	5.50
ΔpH*	+0.20	-0.28	-0.58

$$*\Delta\text{pH} = \text{pH}_{\text{KCl}} - \text{pH}_{\text{H}_2\text{O}}$$

Table 1B. Important soil properties--Total chemical analysis of the untreated soils

Soil	Hilo	Waikane	Molokai
Total elemental analysis (% on oven dried basis)			
LOI	24.61	13.38	14.99
Na ₂ O	0.26	0.42	0.47
MgO	0.73	0.78	0.77
Al ₂ O ₃	32.17	25.28	29.98
SiO ₂	8.85	29.77	25.01
P ₂ O ₅	0.81	0.22	0.40
K ₂ O	0.21	0.32	0.67
CaO	0.00	0.11	0.24
TiO ₂	5.48	5.47	3.75
MnO	0.26	0.23	1.21
Fe ₂ O ₃	26.86	23.59	21.92
Total	100.21	99.54	99.41

Table 1C. Important soil properties--Estimated content of major minerals identified by X-ray analysis

Soil	Hilo	Waikane	Molokai
Estimated mineral content (%)			
Kaolin	--	53.0-58.0	50.0
Quartz	1.0- 5.0	3.0- 5.0	2.0
Gibbsite	10.0-15.0	4.0- 7.0	9.0
Boehmite	--	--	2.0
Goethite	--	15.0-21.0	--
Hematite	--	5.0-10.0	22.0
Magnetite	1.0- 5.0	--	--
Maghemite	5.0-10.0	--	--
TiO ₂	6.0	6.0	4.0
Amorphous material	40.0-56.0		

B. Surface Charge Measurements - Results

The adsorption density of H^+ and OH^- (me/g) was plotted as a function of pH. The curve obtained at each concentration is considered a measure of net charge at that concentration, the assumption being that adsorption of H^+ or OH^- results in the surface gaining a net positive or negative charge, respectively (Fig. 2A, Sect. B of Literature Review). The zero point of charge (ZPC) is, as conventional, taken to be the common point of intersection of the net charge-pH curves at various salt concentrations.

1. Surface charge-pH curves in the presence of KCl

The surface charge-pH curves for the three soils in the presence of KCl are presented in Figs. 7A to 7C. The observed ZPC for the Hilo soil occurs at pH 6.9 - 7.3 (Fig. 7A), 3.1 - 3.9 for the Waikane (Fig. 7B), and 2.5 - 2.9 for the Molokai soil. A summary of ZPC values is presented in Table 2. The differences in ZPC values, which will be discussed in a following section, are easily explained on the basis of the electrochemical properties of the dominant colloids in the respective soils. It is interesting to note the almost symmetrical nature of the net charge-pH curve for the Hilo soil as opposed to the asymmetrical net charge-pH curves of the Waikane and Molokai soils. The latter soils show an excess of negative over positive charges in the pH range between 3 and 7 whereas the Hilo soil on the contrary shows an excess of positive charges. The magnitude of the charges developed per unit change of pH (pH range 3 - 7) is larger in the case of the Hilo soil than for the Waikane or Molokai. It will be shown in the following sections that this trend generally holds

Fig. 7A. Surface charge-pH curves at different concentrations of KCl--Hilo soil.

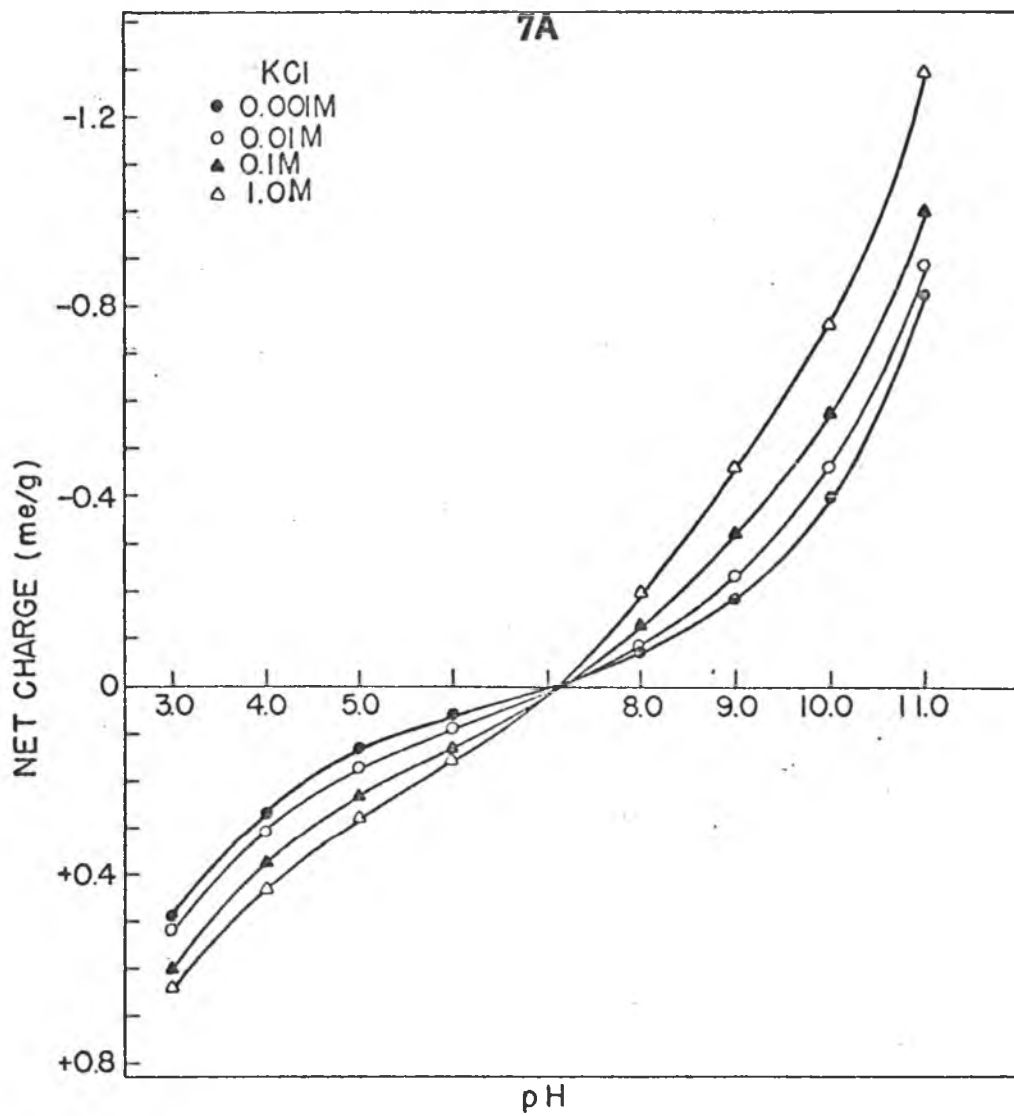

Fig. 7B. Surface charge-pH curves at different concentrations of KCl--Waikane soil.

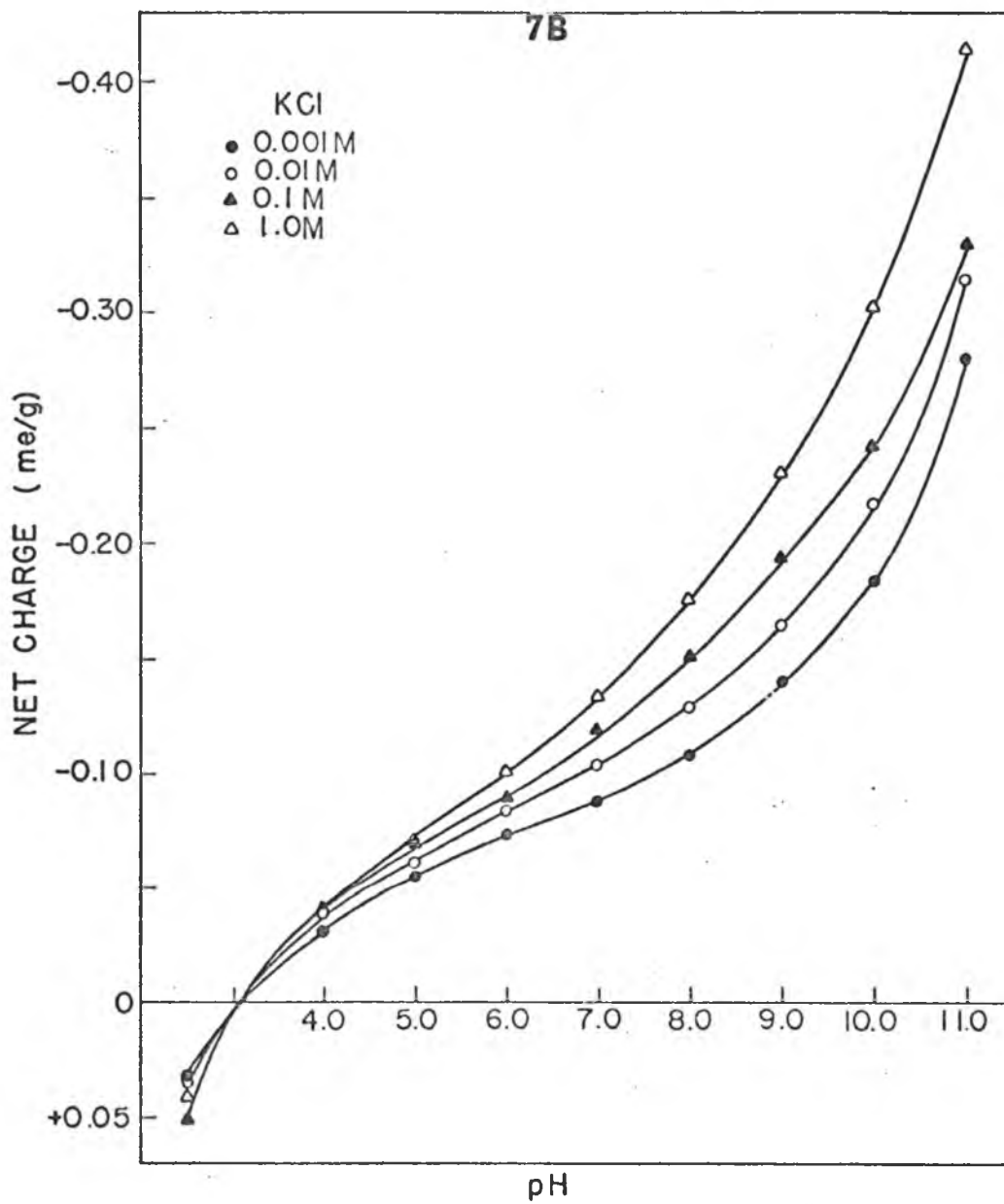

Fig. 7C. Surface charge-pH curves at different concentrations of KCl--Molokai soil.

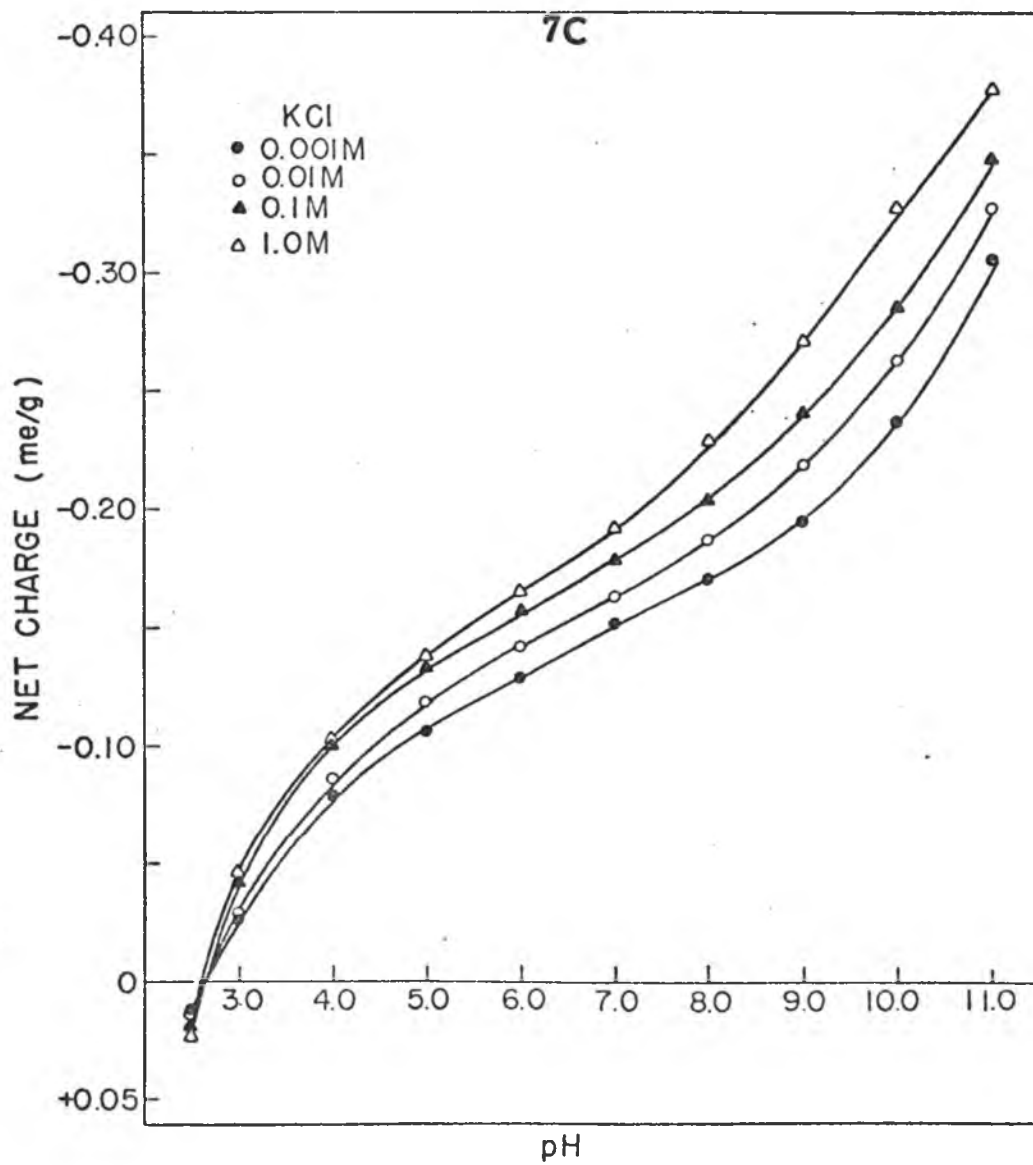

Table 2. Zero point of charge (ZPC) values of soil colloids suspended in different supporting electrolytes

Soil	Hilo	Waikane	Molokai
Supporting electrolyte			
100% KCl	6.9-7.3	3.1-3.9	2.5-2.9
90% KCl + 10% CaCl ₂	6.2-6.9	2.7-3.5	2.5
100% CaCl ₂	6.6-6.9	--	--
90% KCl + 10% K ₂ SO ₄	7.4-8.2	3.7-4.5	3.4-3.8
90% KCl + 10% CaSO ₄	--	4.1	3.2

irrespective of the type of anion or cation in solution. At pH values greater than 7, all three soils possess an excess of negative charges.

2. Surface charge-pH curves in KCl plus CaCl_2

The surface charge-pH curves for the three soils in the presence of KCl plus CaCl_2 are presented in Figs. 8A to 8C. It was observed that the presence of the calcium ion, even in small amounts (the ratio of $\text{Ca}^{2+}:\text{K}^+$ is 1:9 on a molar basis) depressed the intersection point of the net charge-pH curves to lower pH values by about 0.4 pH units for all three soils (Table 2). Because of the interferences due to possible dissolution of soil clays at pH values lower than 3, the significance of the ZPC values in the case of the Molokai and Waikane soils may be questionable. As in the case of KCl, both Molokai and Waikane soils showed an excess of negative charges from pH 3 and above. The Hilo soil, on the other hand, had excess positive charges in the pH range between 3 and 6.5; above this pH, it showed an excess of negative charges. The presence of Ca^{2+} generally causes the surface to become more negatively charged, however, examination of Figs. 8A to 8C indicate that the rate of increase in negative charge is both pH and concentration dependent (compare Figs. 12A - 12F). At the lowest concentrations (10^{-4}M CaCl_2) the surface charge-pH curves behave as if only KCl is present in the system (Figs. 12A, 12C, 12E), however, on increasing the concentration of Ca^{2+} one hundredfold, a very abrupt increase in the net negative charge was observed to occur at pH 7, and the rate of increase became progressively larger as the pH is increased (Figs. 12B, 12D, 12F). Further increase

Fig. 8A. Surface charge-pH curves at different concentrations of KCl + CaCl₂--Hilo soil.

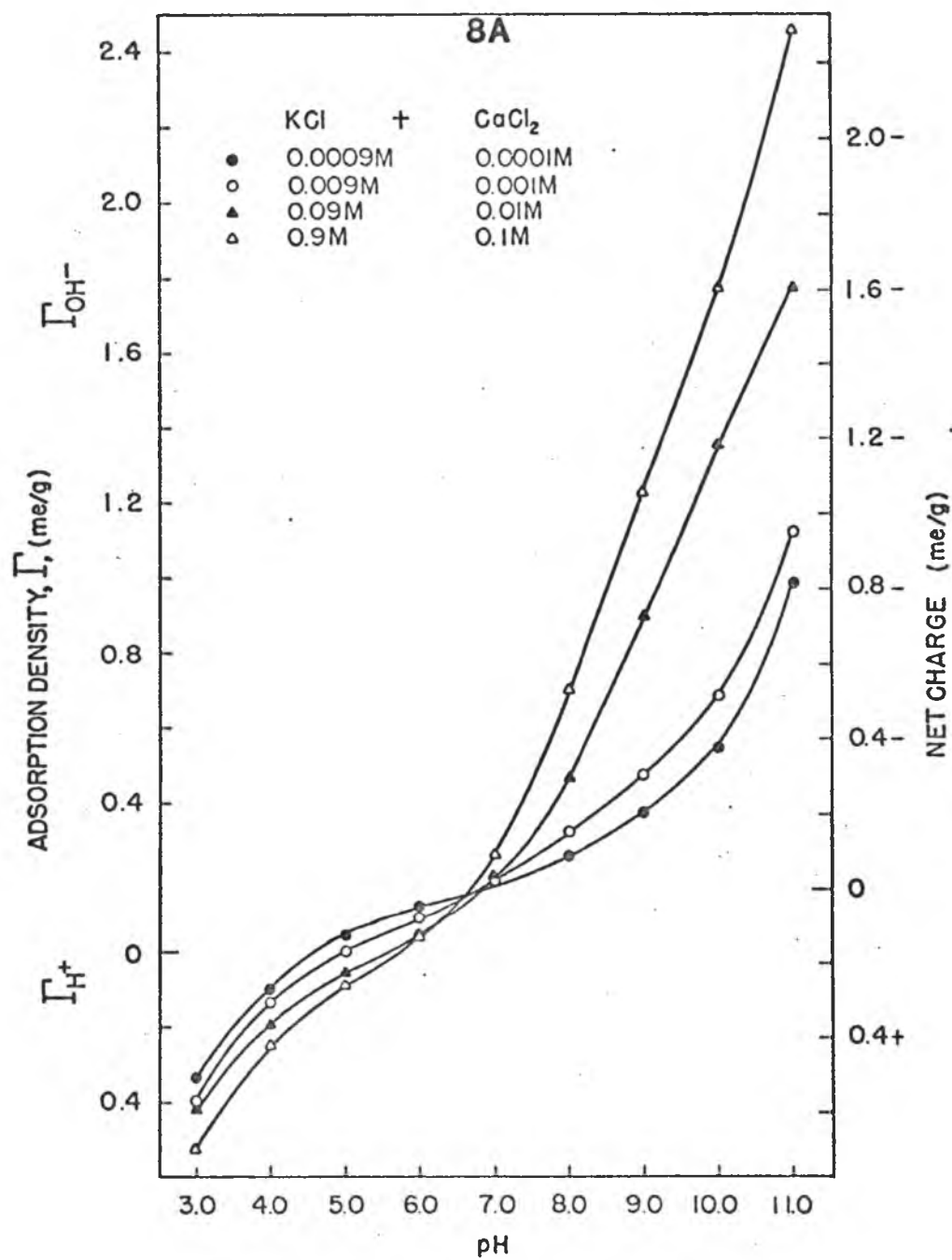

Fig. 8B. Surface charge-pH curves at different concentrations of KCl + CaCl₂--Waikane soil.

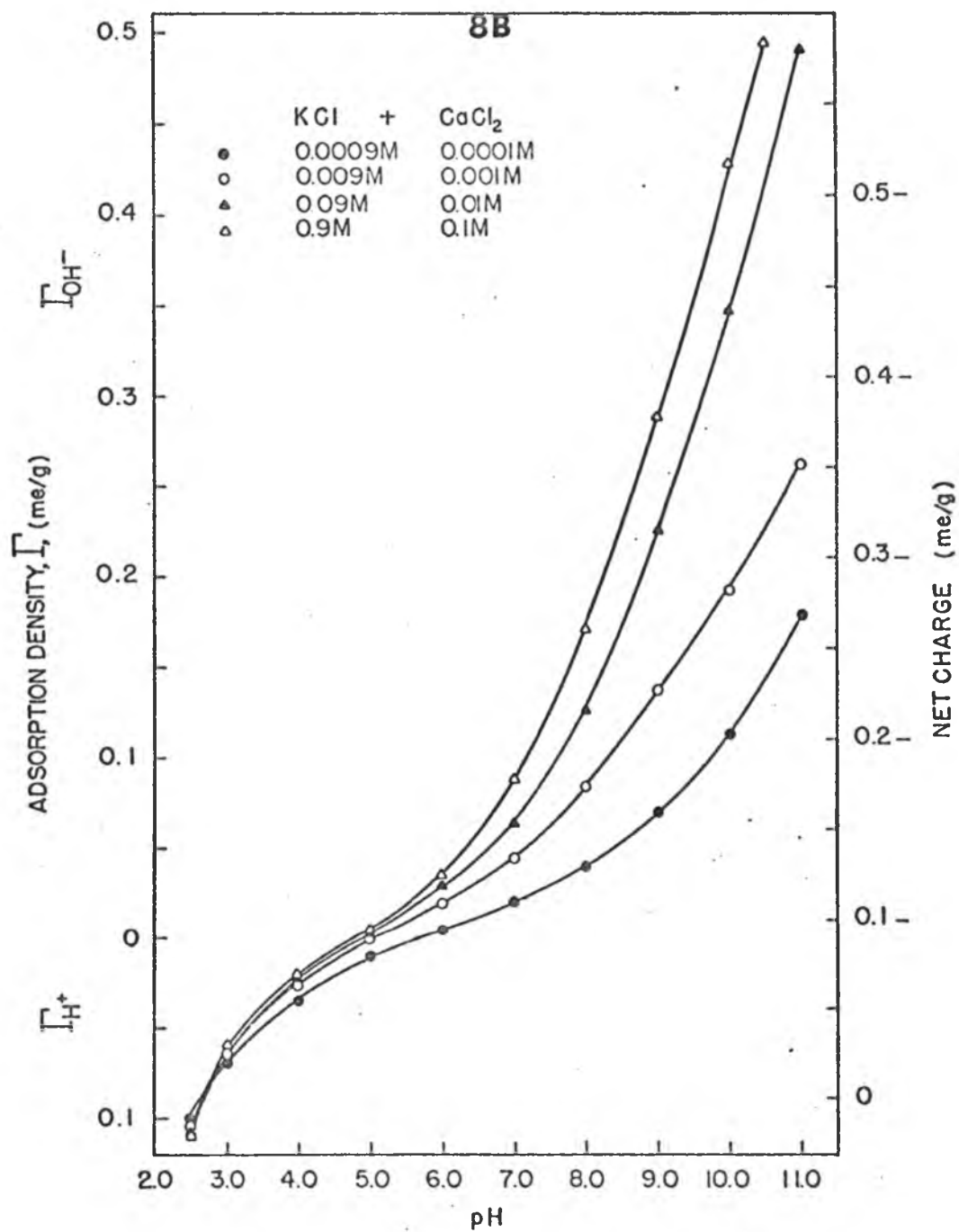
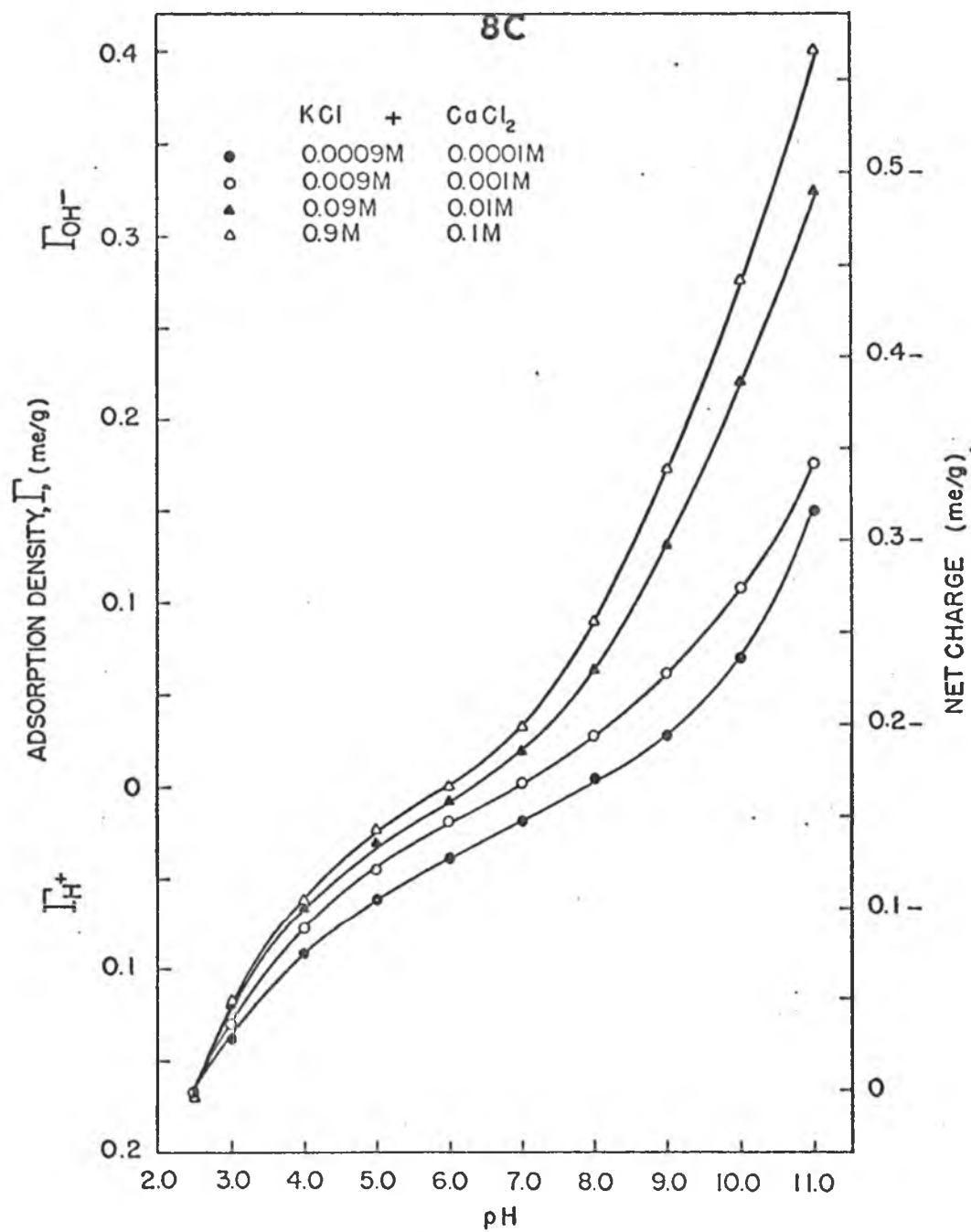

Fig. 8C. Surface charge pH curves at different concentrations of KCl + CaCl₂--Molokai soil.



of Ca^{2+} in solution also increased the net negative charges on the surface, but the rate of increase with pH was small.

The net surface charge in the presence of CaCl_2 only, was also investigated for the Hydrandept (Hilo soil) (Fig. 9). The titrants in this instance were 0.1N HCl and 0.05N $\text{Ca}(\text{OH})_2$. It is interesting to note that the ZPC value (6.6 - 6.8) for this case was practically the same as for the ($\text{KCl} + \text{CaCl}_2$) system. It is very difficult however to distinguish the effect of pH and concentration on the rate of increase in negative charge.

3. Surface charge-pH curves in KCl plus K_2SO_4

In all three soils, the presence of SO_4^{-2} in solution shifted the ZPC to higher pH values by about 0.6 - 0.9 pH units (Table 2). At pH values less than 4, the Molokai and Waikane soils were observed to possess net positive charges, and, net negative charges at higher pH values (Figs. 10A - 10C). The Hilo soil is positively charged at pH 3 - 8, and negatively charged at higher pH's (Fig. 10A). As noted for calcium, the change in net charges in the presence of sulfate ions is observed to be concentration dependent (Fig. 12A - 12F). However, the dependence on pH is less pronounced in the case for sulfate ions. In all three soils, it was observed that the net charge-pH curve in the presence of sulfate ions, was consistently displaced towards the positive side relative to the KCl system, throughout the whole pH range. This may indicate that the SO_4^{-2} -surface interaction may not be as pH dependent as was previously thought (Hingston *et al.*, 1968, 1972).

Fig. 9. Surface charge-pH curves for the Hilo soil at different concentrations of CaCl_2 .

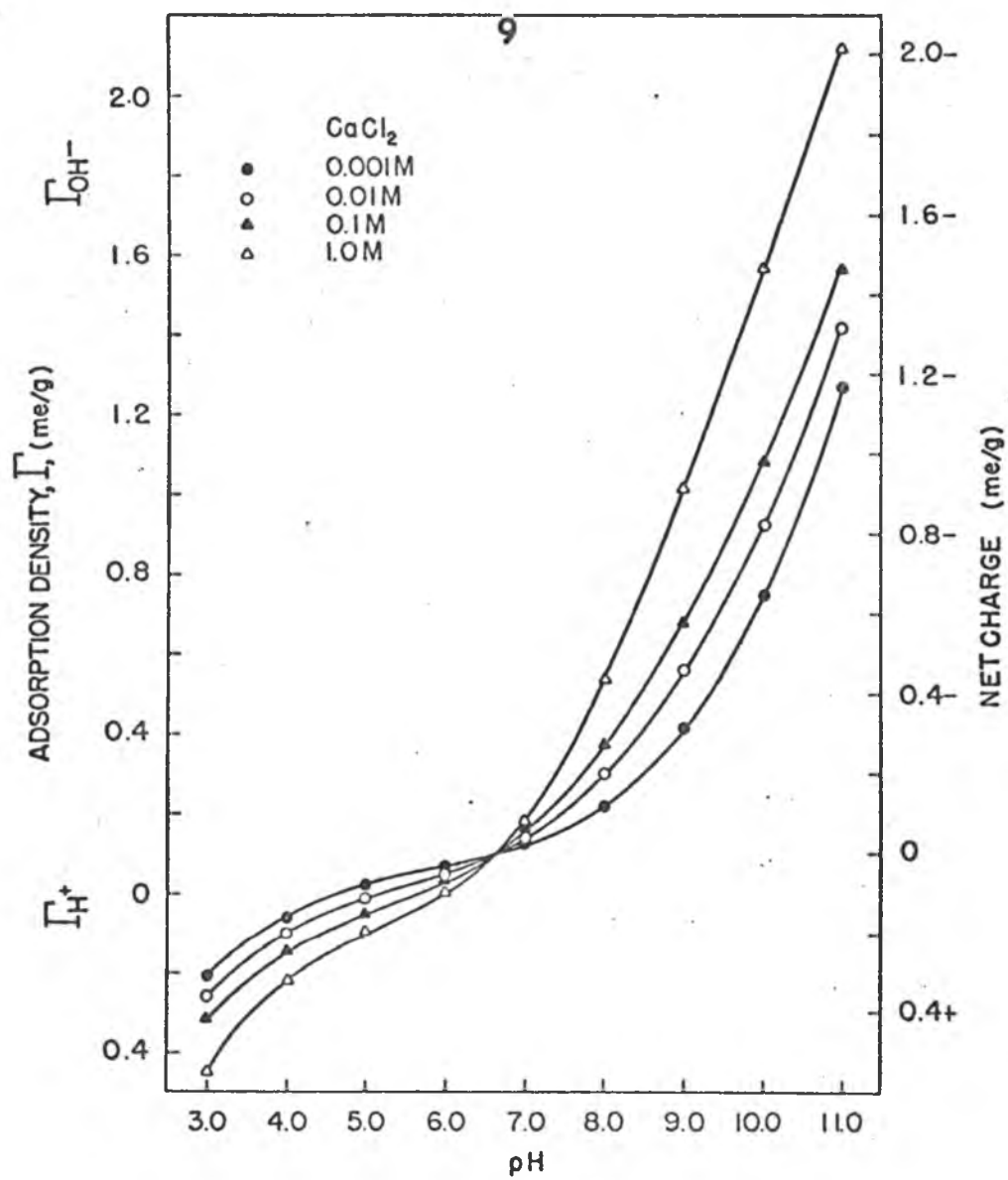

Fig. 10A. Surface charge-pH curves at different concentrations of KCl + K₂SO₄--Hilo soil.

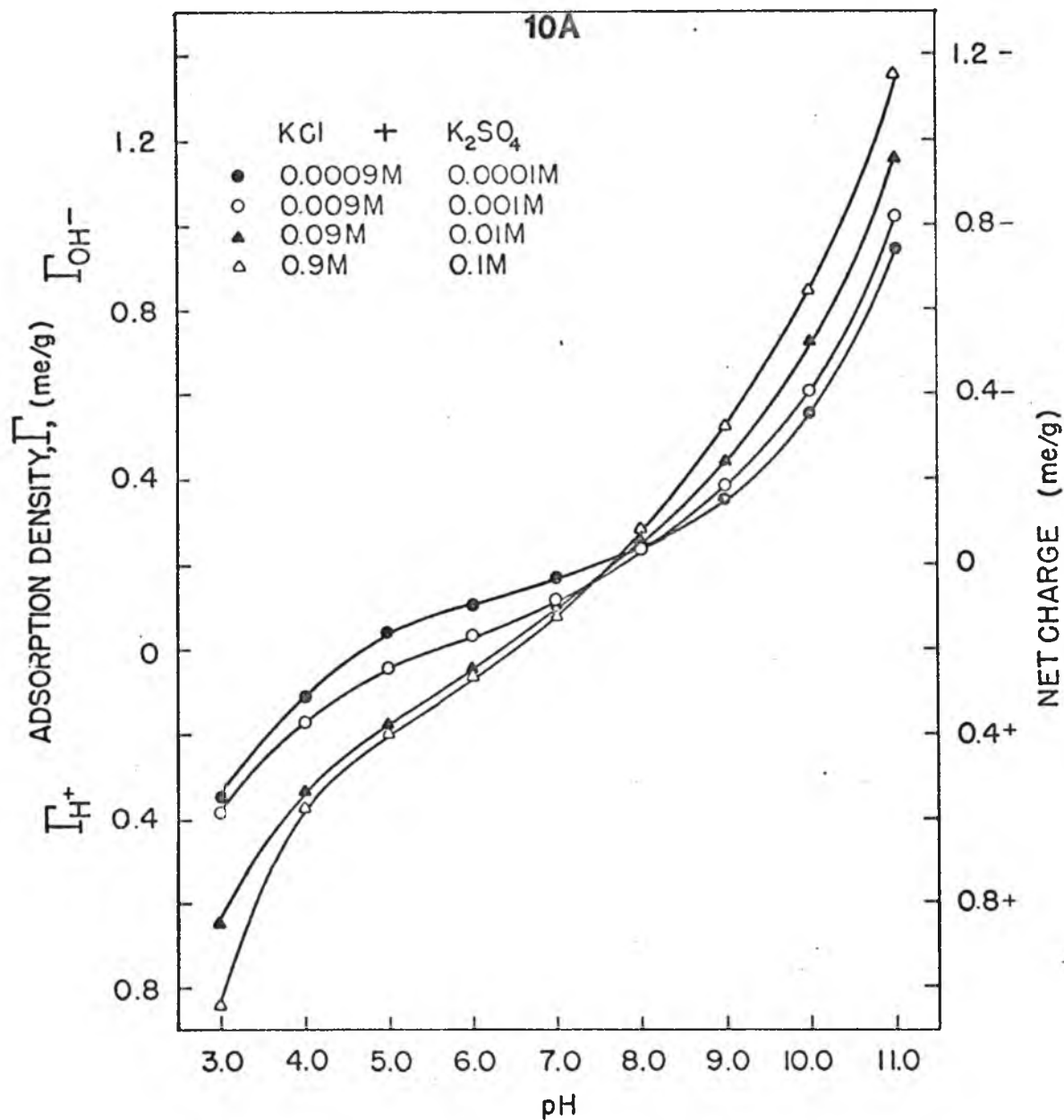

Fig. 10B. Surface charge-pH curves at different concentrations of KCl + K₂SO₄--Waikane soil.

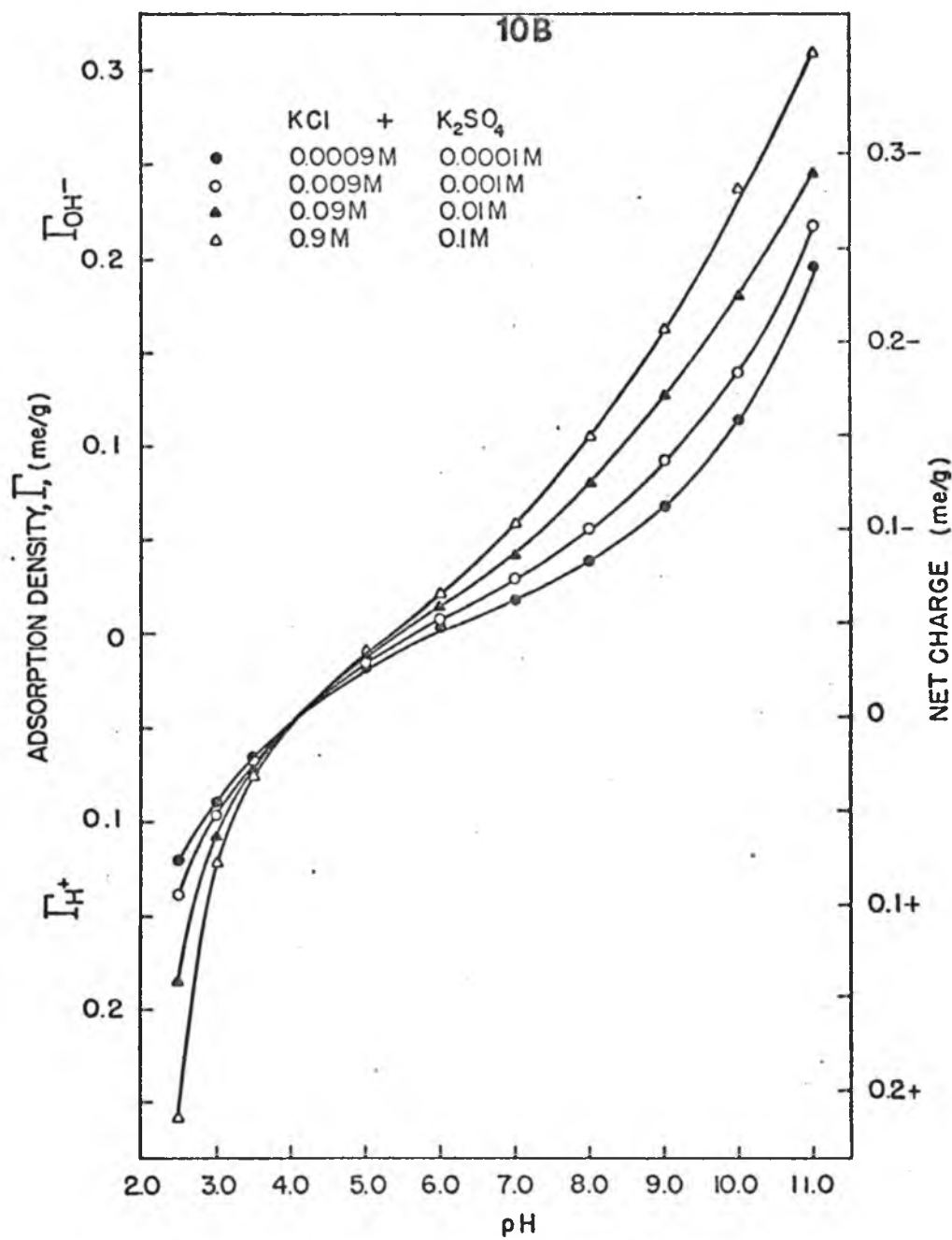
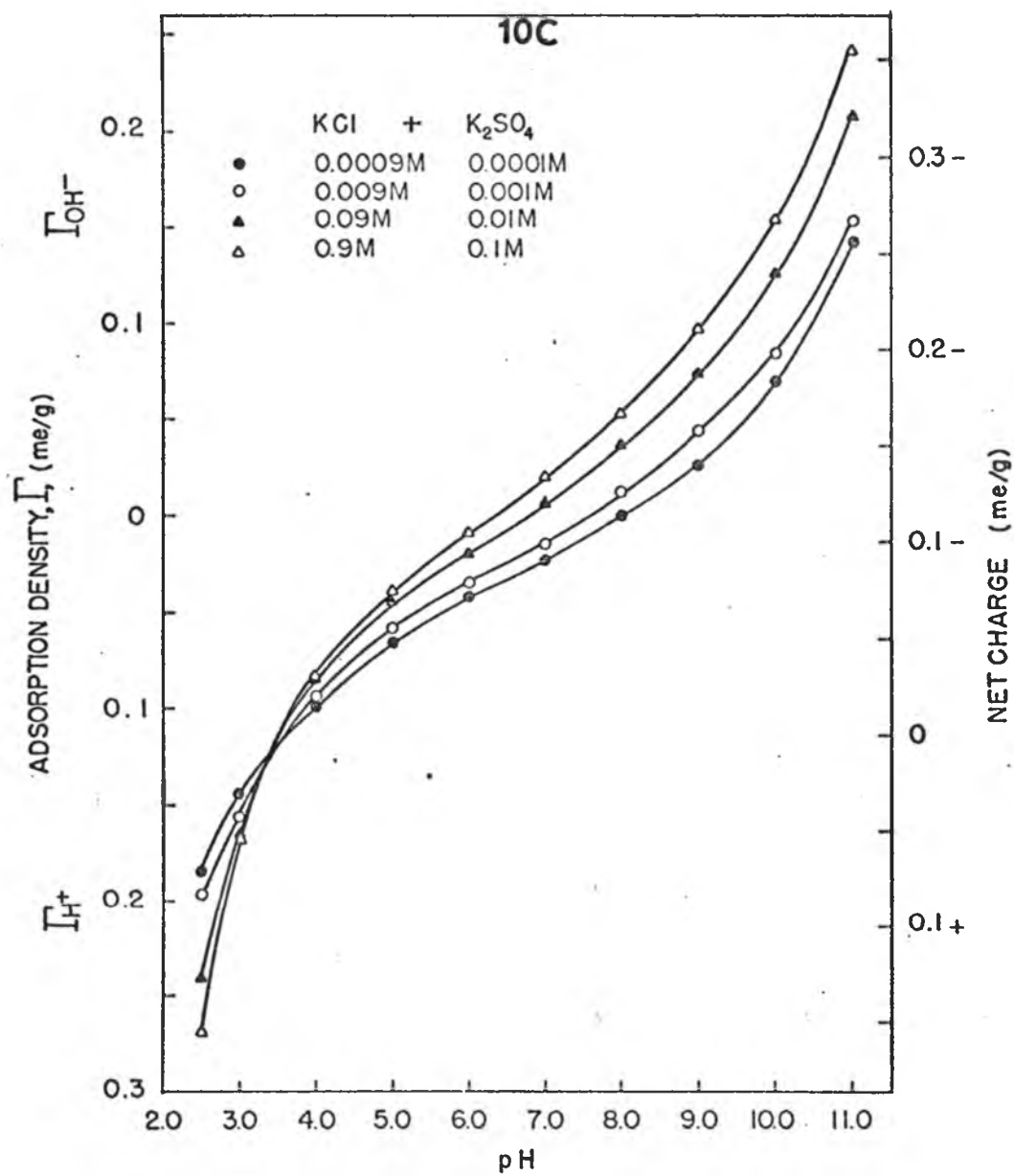

Fig. 10C. Surface charge pH curves at different concentrations of $\text{KCl} + \text{K}_2\text{SO}_4$ -Molokai soil.



4. Surface charge-pH curves in KCl plus CaSO₄

The surface charge-pH curves for the Waikane and Molokai soils are presented in Figs. 11A and 11B respectively. Similar data could not be obtained for the Hydrandep because of insufficient available time to perform the experiment. Solubility problems necessitated working with two concentrations only. The ZPC was observed to occur at pH 4.1 for Waikane and pH 3.2 for the Molokai soil (Table 2). Comparison of the above values with those obtained in the presence of (KCl plus K₂SO₄), indicate that they are practically the same (3.7 - 4.5 for Waikane, and 3.4 - 3.8 for Molokai). It is therefore reasonable to assume that the values of the ZPC as obtained for these soils are determined solely by sulfate ions. Yet further examinations of Figs. 11A and 11B indicate that calcium influences the magnitude of net charge also at pH values higher than the ZPC, and that the influence of calcium over sulfate becomes progressively greater as the pH is increased. This is readily explained on the basis of the results presented in the previous sections in which it was shown that calcium interaction with the surface is strong only when the surface is negatively charged whereas the SO₄⁻²-surface interaction is relatively less dependent on surface charge (or pH).

C. Surface Charge Measurements - Discussions

1. Clay mineralogy and surface charge characteristics

The surface charge-pH curves generally reflected the influence of the dominant colloids in the respective soils. The Hilo soil being dominated by amphoteric colloids shows charge curves that are clearly characteristic of amphoteric systems. It also shows the

Fig. 11A. Surface charge-pH curves at different concentrations of KCl + CaSO₄--Waikane soil.

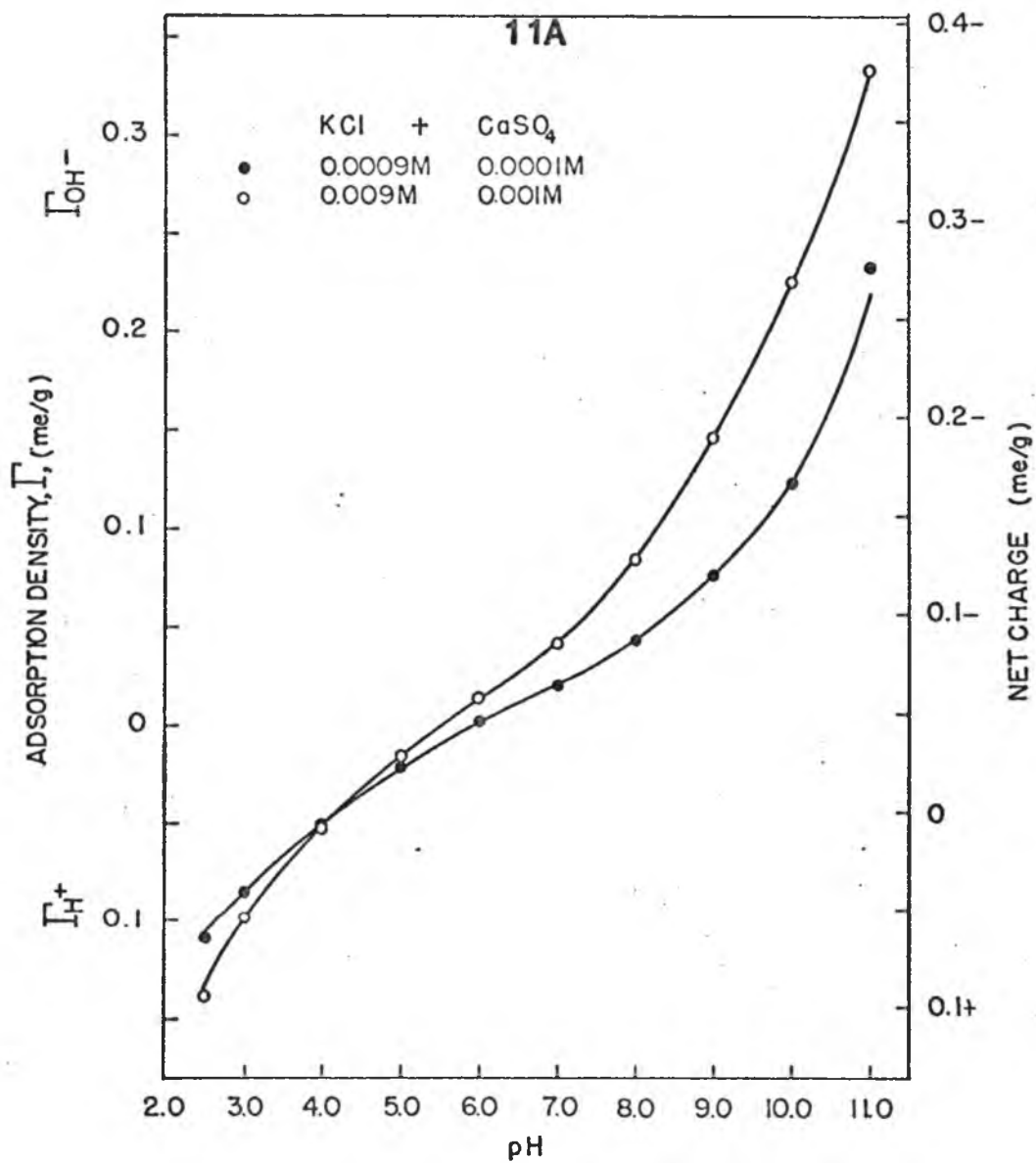

Fig. 11B. Surface charge-pH curves at different concentrations of KCl + CaSO₄--Molokai soil.

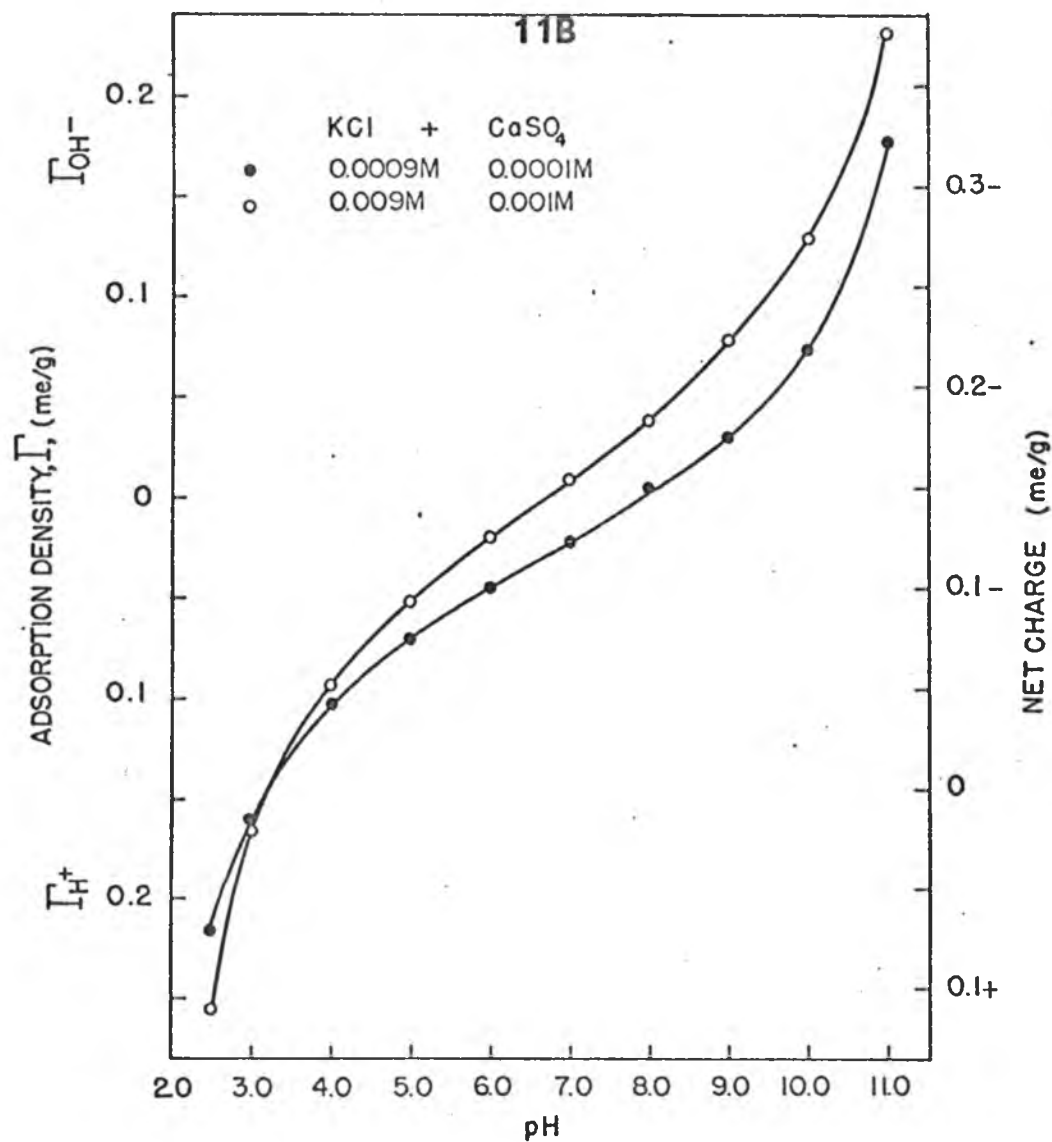

Fig. 12A-12B. Surface charge-pH curves at two electrolyte concentrations as a function of different ions in the supporting electrolyte--Hilo soil.

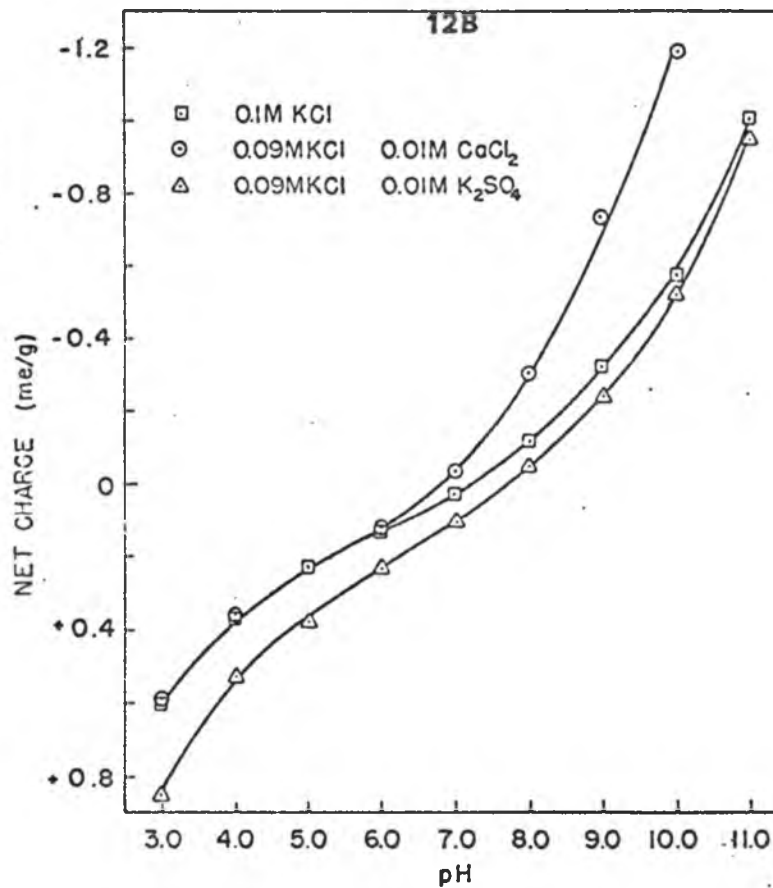
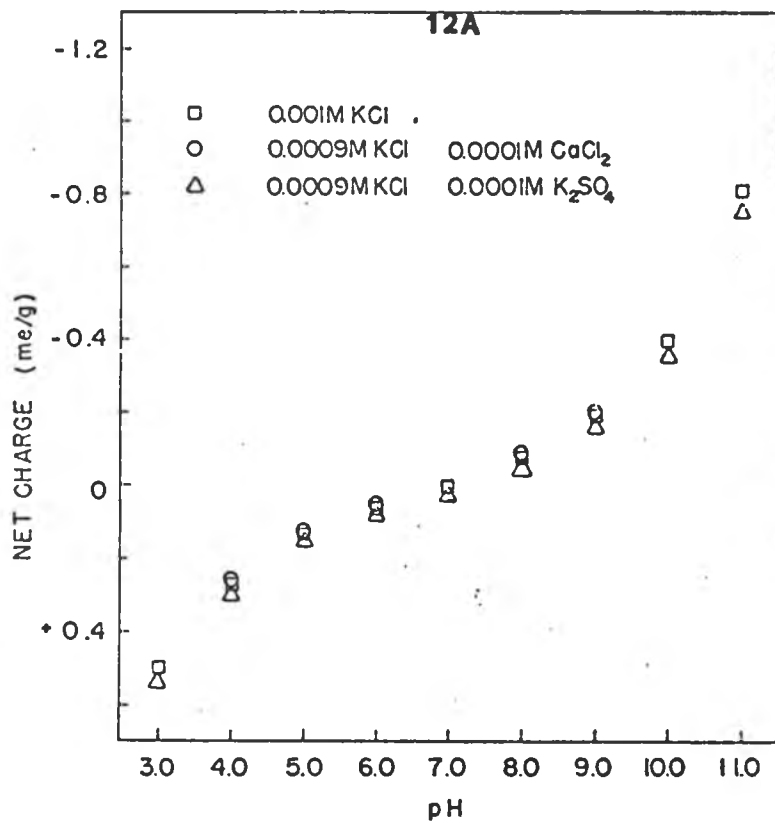

Fig. 12C-12D. Surface charge-pH curves at two electrolyte concentrations as a function of different ions in the supporting electrolyte--Waikane soil.

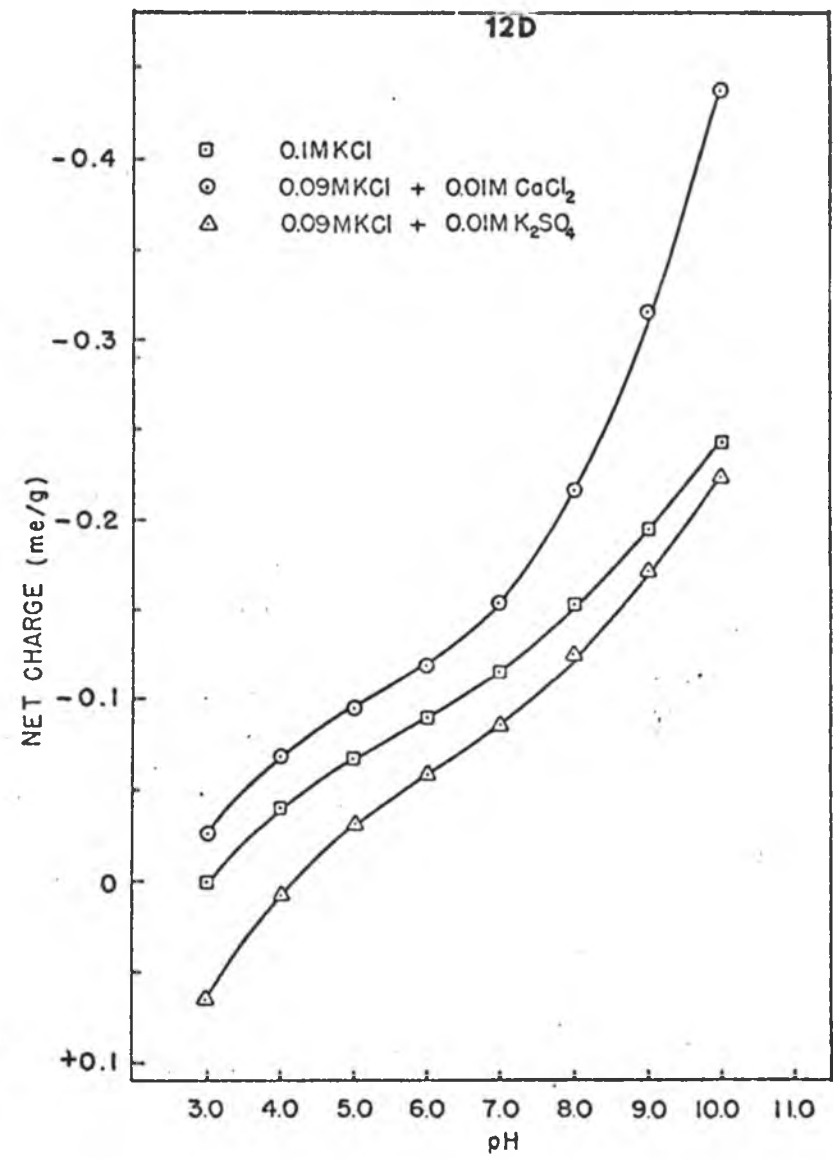
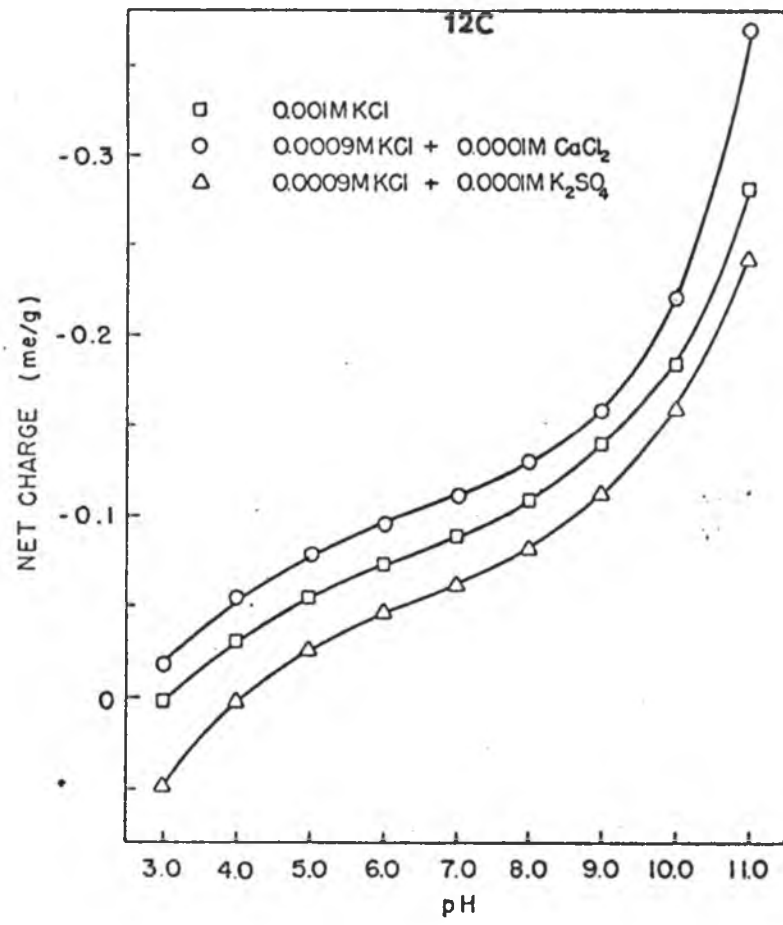
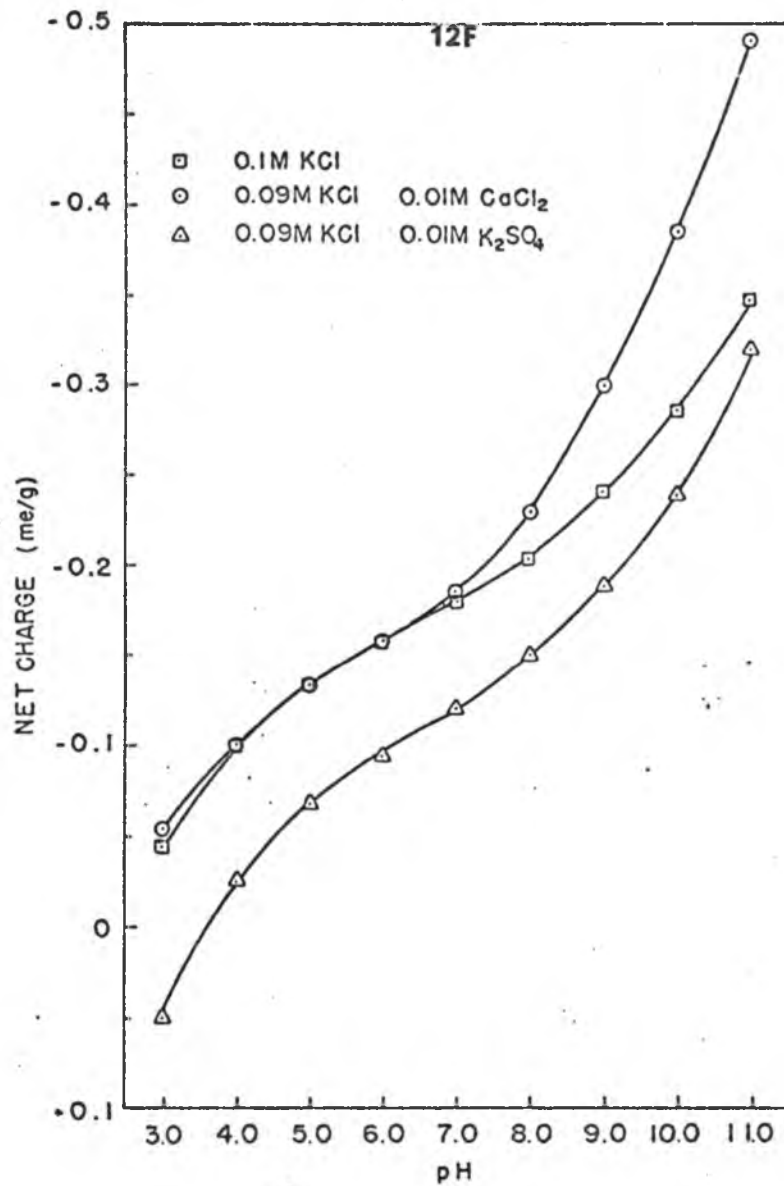
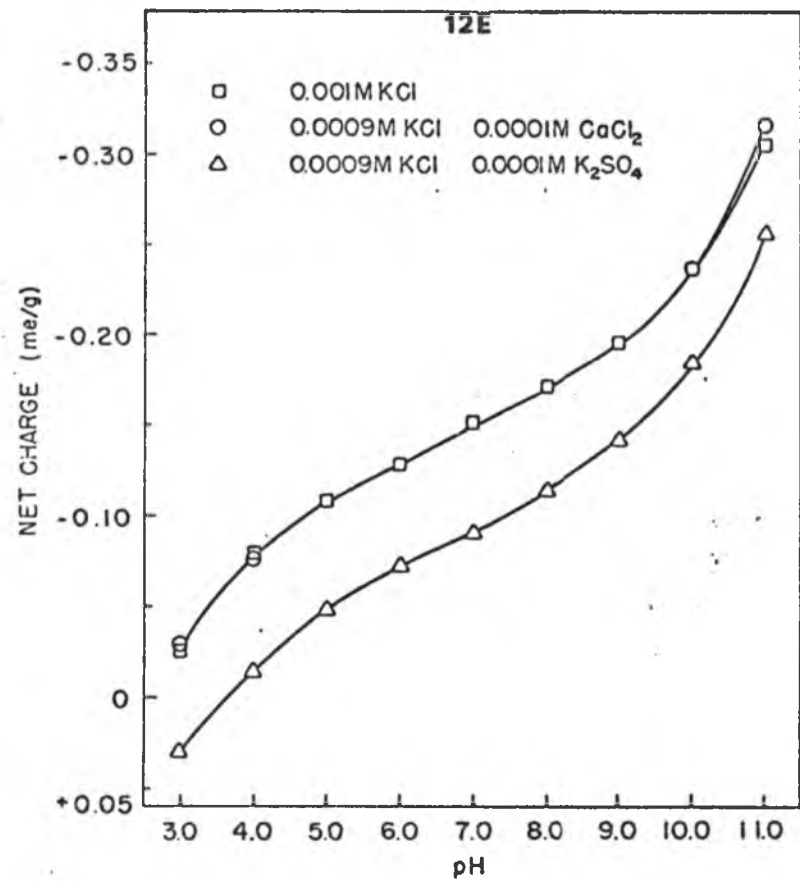

Fig. 12E-12F. Surface charge-pH curves at two electrolyte concentrations as a function of different ions in the supporting electrolyte--Molokai soil.



greatest response to pH changes. The Waikane and the Molokai soils on the other hand, show charge curves that reflect the dominance of 1:1 layer silicates. The electrochemical properties, and sources of surface charge of colloids found in these soils have been discussed previously. The results obtained for the Waikane and especially the Molokai soil were surprising however, since they contain fair amounts of oxides, and their ZPC's were expected to be higher than the results indicated. The influence of the oxides on the net charge was, nevertheless, evident as only small gains in net charge were noted with pH change or electrolyte concentration. It was noticed that the increase in net negative charge was relatively small in the pH range between 3 and 6 even at the highest concentration. This can be explained on the basis of mutual flocculation between the positively charged oxides and hydroxides of Al and Fe, and the negatively charge layer silicates. At pH higher than 7, the surface charge-pH curves show a greater increase in slope with each change in pH, signifying greater gain in net negative charges. At these high pH values the oxides become negatively charged (Parks, 1965, 1967; Hingston et al., 1972; Breeuwsma, 1973 among others). Furthermore, the 1:1 layer silicates also may gain more negative charges (Schofield et al., 1954). Therefore, mutual enhancement of a similar charge (rather than mutual flocculation and reduction of charge) occurs, which consequently is reflected in a greater gain in net negative charges at higher pH values.

On the other hand, surface charge-pH curves for the Hilo soil generally show rapid gain in net charge above and below the ZPC.

Since the colloidal constituents are predominantly amphoteric, the surface potential and charge characteristics are similarly affected by pH. Reported ZPC values for these minerals also lie in a relatively narrow pH range, around 7 - 9 (Parks, 1965, 1967; Hingston et al., 1972; Ahmed, 1969; Wada et al., 1958; Limura, 1961). This is well confirmed by the ZPC noted for the Hilo soil.

2. Effect on the surface charge of different ions in solution

Ions such as K^+ , Na^+ , Cl^- , and NO_3^- are generally considered to be non-specifically adsorbed by oxides (Parks et al., 1962; Atkinson et al., 1967). They are presumed to be adsorbed in a solvated state and their adsorption is largely electrostatic in origin and arises from the requirement of electroneutrality of the double layer. This assumption, however, is not universally accepted (Ahmed, 1969, 1972). Calcium (Breeuwsma, 1973; Tadros et al., 1969), sulfate (Breeuwsma, 1973), phosphate and silicate (Hingston et al., 1968, 1972) on the other hand, are specifically adsorbed by oxides. They are presumably adsorbed either in a partly dehydrated or completely dehydrated form. The anions in particular are visualized as being able to replace the hydroxyl groups in the first coordination shell of metal complexes (Hingston et al., 1967, 1968; Ahmed, 1969, 1972). For the purpose of comparing the relative effects of K^+ , Ca^{2+} , SO_4^{2-} , and Cl^- on the charge characteristics of soil colloids, it is not necessary to invoke specific or non-specific adsorption of K^+ or Cl^- , if they are present in the supporting electrolyte simultaneously with Ca^{2+} or SO_4^{2-} . Thus the relative affinity of the surface for Ca^{2+} for instance can be observed by comparing the surface charge-pH

curves of a pure KCl system with one containing both K^+ and Ca^{2+} . Similar comparison between Cl^- and SO_4^{-2} could be done also. Using this approach it was shown (Sect. B.2.) that the Ca^{2+} -surface interaction is strongly dependent on the concentration of Ca^{2+} and on the surface charge of the colloids. Furthermore, at these low concentrations, when the ratio of K:Ca is 9:1, the Hilo and Molokai soils did not show sufficiently larger preference for Ca^{2+} over K^+ (specific adsorption) to cause appreciable change in the charge characteristics (although in the case of the Waikane soil some preference for Ca^{2+} was indicated). However, when the concentration of Ca^{2+} in the supporting electrolyte was raised one hundredfold ($10^{-4}M$ - $10^{-2}M$) and the surface was negatively charged, all three soils showed clear indications of such preference even though the molar ratio of Ca:K was still maintained at 1:9. Further examination of Figs. 8A - 8C also indicate that a saturation limit may have been reached in Ca^{2+} adsorption at a concentration of $10^{-2}M$ because further increase in concentration showed little increase in negative charge. Such a reaction was previously found to occur in the case of anion interaction with metal oxides (Ahmed et al., 1969).

Comparisons of the surface charge-pH curves between a Cl^- , and Cl^- plus SO_4^{-2} system indicate that the SO_4 -surface interaction is much stronger than Cl^- -surface interaction even at very low concentrations of SO_4^{-2} in solution. A saturation limit in the adsorption of sulfate is also observed to occur at a concentration of $10^{-2}M$. Unlike calcium, the specific interaction between sulfate and colloid surface is less dependent on surface charge or pH (Figs. 12A - 12F).

This implies that except at very high pH values (or highly negatively charged surfaces) sulfate ions should exert a greater modifying influence on surface charge than calcium. The data obtained for the Molokai and Waikane soils (Table 3, and Figs. 11A, 11B) indeed show that up to pH 6, the surface charge characteristics are almost entirely influenced by sulfate ions; the influence of calcium being significant only at pH values greater than 7.

A shift in the ZPC is often used as an indicator for specific adsorption (Hingston et al., 1968, 1972; Parks, 1965, 1967; Breeuwsma, 1973) although the direction in which this shift ought to follow depends on whether a cation or an anion is specifically adsorbed, but this direction is not generally agreed upon. Evidence of a shift of the ZPC of goethite to lower pH values in the presence of specifically adsorbed anions was presented by Hingston and co-workers (1968, 1972). Similar shifts in the ZPC of two Hawaiian soils (Gibbsihumox and Hydrandept) in the presence of phosphate was also reported by El-Swaify and Sayegh (1975). The presence of sulfate and calcium ions on the other hand have been reported to cause the ZPC of hematite to shift to higher and lower pH values respectively (Breeuwsma, 1973). Keng and Uehara (1974) have also reported trends similar to that observed by Breeuwsma. The results obtained in this study are more in accordance with the latter author's observations.

Conclusions drawn from observations of the preceding sections are summarized as follows:

- (a) Ion specificity - in a chemical environment in which K^+ and Cl^- greatly exceeds Ca^{2+} and SO_4^{2-} , the order of adsorption are:

Table 3. Net charge in the presence of different electrolyte combinations. Total ionic concentration is 0.01M

Electrolyte	KCl + CaCl ₂	KCl + CaSO ₄	KCl + K ₂ SO ₄
pH	Net charge (me/g)	Net charge (me/g)	Net charge (me/g)
<u>Waikane soil</u>			
2.5	+0.016	+0.094	+0.096
3.0	-0.028	+0.054	+0.054
4.0	-0.064	+0.008	+0.004
5.0	-0.088	-0.028	-0.028
6.0	-0.110	-0.058	-0.052
7.0	-0.134	-0.086	-0.072
8.0	-0.174	-0.128	-0.100
9.0	-0.226	-0.188	-0.136
10.0	-0.286	-0.268	-0.184
11.0	-0.352	-0.370	-0.268
<u>Molokai soil</u>			
2.5	0.0	+0.110	+0.082
3.0	-0.036	+0.018	+0.042
4.0	-0.088	-0.054	-0.020
5.0	-0.122	-0.094	-0.056
6.0	-0.146	-0.126	-0.080
7.0	-0.168	-0.154	-0.100
8.0	-0.194	-0.184	-0.126
9.0	-0.228	-0.224	-0.158
10.0	-0.274	-0.276	-0.200
11.0	-0.374	-0.376	-0.268

- (1) $K^+ = Ca^{2+}$ at low concentrations of Ca^{2+} ($10^{-4} M Ca^{2+}$) irrespective of the sign of the surface charge.
- (2) $K^+ = Ca^{2+}$ at higher concentrations of Ca^{2+} ($10^{-2} M Ca^{2+}$) when the surface is positively charged.
- (3) $K^+ < Ca^{2+}$ at high concentration of Ca^{2+} ($10^{-2} M Ca^{2+}$) when the surface approaches the ZPC, and the preference for Ca^{2+} increases with increasing negative charge.
- (4) $SO_4^{-2} > Cl^-$ at all concentrations and the SO_4^{-2} -surface interaction is less dependent on the sign of the surface charge.

(b) Relative influences on surface charge - Using the charge characteristic in the pure KCl system as a basis for comparison, the presence of Ca^{2+} increases the negative charge relatively more than suppressing the positive charges; sulfate ions not only increase positive surface charges but also suppress development of negative charges. When both Ca^{2+} and SO_4^{-2} are present, the resulting surface charge characteristics reflect more the influence of SO_4^{-2} rather than Ca^{2+} , until the surface has become highly negatively charged.

Several field observations, such as the small change in pH upon addition of large quantities of lime (Matsusaka et al., 1950), increased cation exchange capacity with increasing pH (Mekaru and Uehara, 1972; Barber et al., 1972; Wada et al., 1958 among others), and high adsorption capacity for Ca^{2+} (Stoop, 1974), phosphates and

sulfates (Fox, 1973; Hasan et al., 1970; Mekarū et al., 1972) in highly weathered soils are readily explained on the basis of the results presented in the preceding section. On the other hand, the observed effects on surface charge appear to be inconsistent with other field observations on similar soils. For example losses of potassium due to leaching were shown to be reduced on addition of $(\text{NH}_4)_2\text{SO}_4$ to a Hydrandept (Ayres et al., 1953); increased cation adsorption capacity and cation retention on applying phosphate to soils have also been reported (Mekarū et al., 1972; Stoop, 1974). This apparent inconsistency may be explained on the basis of Breeuwsma's work (Breeuwsma, 1973) in which it was shown that an excess of charge in the Stern layer relative to the surface (superequivalent adsorption) results in charge reversal (Fig. 1). Thus specific adsorption of sulfate for instance causes an excess of negative charges in the Stern layer relative to the positive charges on the colloid surface with the net result being that more of the counter ions in the diffuse layer are cations.

3. Probable charging mechanisms

Surface charge in the presence of K^+ and Cl^- . The general consensus is that K^+ and Cl^- are indifferent, therefore the process by which the surface acquires charges is essentially that proposed by Parks and de Bruyn (1962), (Fig. 2A).

Surface charge in the presence of SO_4^{2-} . As discussed previously, the surface charge in the presence of SO_4^{2-} is strongly dependent on the concentration of sulfate ions in solution. The results obtained in this study are best explained by the mechanism

proposed by Ahmed (1969, 1972), (Fig. 2B). However, in view of the relatively strong SO_4^{-2} -surface interactions even at pH values higher than the ZPC, it is probable that the mechanism in Fig. 2B could very well operate at pH less than ZPC and at pH greater than ZPC, but the reaction will become increasingly more difficult as the surface become increasingly more negative. Thus in the region of negative surface charge, in addition to the acidic dissociation of the surface hydroxyl groups (Fig. 2A), a basic dissociation of these groups and their subsequent replacement by SO_4^{-2} (Fig. 2B) may also occur. The reaction taking place in the region $\text{pH} < \text{ZPC}$ is already described (section B.1. of Literature Review). The net result of such a surface reaction is that the liberated OH^- groups cause an increase in the pH of the bulk solution regardless of the sign of the surface charge. In more practical terms, the above mechanism predicts that the pH of a soil would be higher if measured in K_2SO_4 than in KCl . The work of Mekaruru and Uehara (1972) has indeed shown that in all soils studied which also included a soil with mostly permanent negative charges, the pH in K_2SO_4 was higher than in KCl in all cases, irrespective of the sign of the charge on the colloid (which is indicated by the sign of the quantity ΔpH). A similar trend was also indicated on examining the data by El-Swaify and Sayegh (1975); whereby a consistently higher pH value in Na_2SO_4 as opposed to NaCl was also indicated on studies on other Hawaiian soils (Stoop, 1974).

Surface charge in the presence of Ca^{2+} . The negative surface charge results primarily from an acidic dissociation of the surface hydroxyl group (Fig. 2A), and increases with increasing pH and

proposed by Ahmed (1969, 1972), (Fig. 2B). However, in view of the relatively strong SO_4^{-2} -surface interactions even at pH values higher than the ZPC, it is probable that the mechanism in Fig. 2B could very well operate at pH less than ZPC and at pH greater than ZPC, but the reaction will become increasingly more difficult as the surface become increasingly more negative. Thus in the region of negative surface charge, in addition to the acidic dissociation of the surface hydroxyl groups (Fig. 2A), a basic dissociation of these groups and their subsequent replacement by SO_4^{-2} (Fig. 2B) may also occur. The reaction taking place in the region $\text{pH} < \text{ZPC}$ is already described (section B.1. of Literature Review). The net result of such a surface reaction is that the liberated OH^- groups cause an increase in the pH of the bulk solution regardless of the sign of the surface charge. In more practical terms, the above mechanism predicts that the pH of a soil would be higher if measured in K_2SO_4 than in KCl . The work of Mekar and Uehara (1972) has indeed shown that in all soils studied which also included a soil with mostly permanent negative charges, the pH in K_2SO_4 was higher than in KCl in all cases, irrespective of the sign of the charge on the colloid (which is indicated by the sign of the quantity ΔpH). A similar trend was also indicated on examining the data by El-Swaify and Sayegh (1975); whereby a consistently higher pH value in Na_2SO_4 as opposed to NaCl was also indicated on studies on other Hawaiian soils (Stoop, 1974).

Surface charge in the presence of Ca^{2+} . The negative surface charge results primarily from an acidic dissociation of the surface hydroxyl group (Fig. 2A), and increases with increasing pH and

increasing electrolyte concentration. The results presented imply that the above process is enhanced in the presence of Ca^{2+} , thus more H^+ would be displaced into the bulk solution, but this enhancement is most effective only as the surface approaches the ZPC and increases with increasing pH (negative surface charge). This reaction predicts that (a) when the colloid is highly positively charged, the pH measured in CaCl_2 and KCl should be almost identical, (b) as the surface charge on the colloid approaches the ZPC, the pH in CaCl_2 would be lower than that in KCl . This difference should then increase in magnitude as the surface charge become increasingly more negative. Examination of the data presented by Stoop (1974) indicate that the smallest difference in pH measured in CaCl_2 and NaCl was obtained for the Honokaa soil (Typic Hydrandept) which, judging from the ΔpH value ($\text{pH}_{\text{NaCl}} - \text{pH}_{\text{H}_2\text{O}}$), has surface charge closest to the ZPC (at the ZPC, $\Delta\text{pH} = 0$). The soils which are more negatively charged (Halii, Wahiawa, and Waialua) showed greater differences between the pH measured in CaCl_2 and NaCl . The effect of added calcium on the availability of phosphate (Stoop, 1974) is best explained on the basis of charge reversal (Breeuwsma, 1973). Superequivalent adsorption of Ca^{2+} , causes an excess of positive charge to occur in the Stern layer relative to the negative charge on the surface, as a result, the counter ions in the diffuse layer are anions.

D. Colloidal Stability Measurements - Results

All results are presented as stability diagrams in which the Jackson Turbidity Unit (JTU) is used as a measure of colloidal

stability ($JTU > \text{zero}$) and flocculation ($JTU = \text{zero}$). These values were plotted against pH at several concentrations of KCl.

1. Hilo soil

Fig. 13A shows that the stability diagram for this soil in distilled water is almost symmetrical, with the flocculated region centered at about pH 7.6. The symmetrical nature of the stability diagram was expected because the surface charge-pH curve in KCl (Fig. 7A) was also symmetrical, with the ZPC located around pH 6.9 - 7.3 (Table 2). On adjusting the electrolyte concentration to 0.001M KCl, the symmetrical nature of the stability diagram was reduced and the pH had to be raised to above 9 before stability was regained, although the extent of dispersion was not as large as in the pH region below 7. Further increase in electrolyte concentration caused greater flocculation of the colloidal suspensions at pH values above 7 than below . The suspensions became flocculated throughout the whole pH range when the electrolyte concentration was increased to 0.1M KCl. Previously, observations on the viscosity of Akaka clay (also a Typic Hydrandept) suspended in 0.005N NaCl had shown trends similar to the behavior noted here for the Hilo soil (Dangler, 1973). Maximum viscosity (approximating a flocculated system) occurred at pH 7 while the lowest viscosity (approximating a dispersed system) occurred at pH 4. His viscosity data also indicate redispersion at pH 10 although the magnitude of dispersion may not have been as great as at pH 4. The observed stability diagram for the Hilo soil is qualitatively similar to that of pure goethite (El-Swaify, 1975) although this mineral could not be detected in the soil's X-ray diffractogram.

Fig. 13A. Colloidal stability diagrams as a function of different concentrations of KCl and pH--Hilo soil.

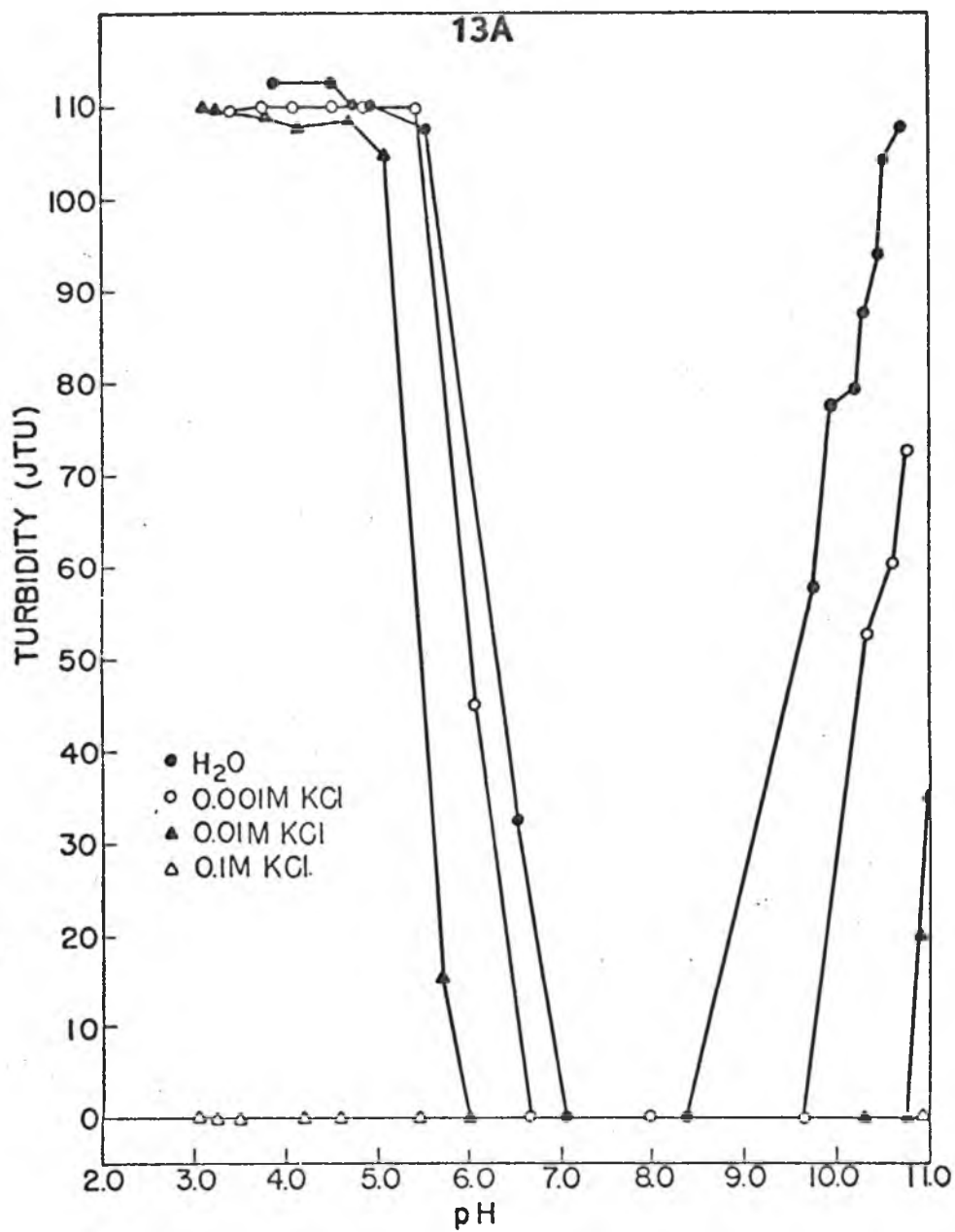

2. Waikane soil

The stability diagram for the Waikane soil suspension is asymmetrical (Fig. 13B). This trend was anticipated, because of the asymmetrical nature of its surface charge-pH curve (Fig. 7B). Stable dispersions of this soil were obtained in distilled water at pH values of 4 and above, which is about 0.5 - 0.9 pH units above the ZPC in KCl (Table 2). Adjustment of the electrolyte concentration to 0.001M KCl required a pH change to about 5.5 before full colloidal stability was again reestablished. A sudden drop in turbidity was observed on increasing the electrolyte concentration from 0.01M - 0.1M, but full flocculation was achieved only in the presence of 1.0M KCl. This trend is remarkably similar to the stability diagrams of pure kaolinite in NaCl (El-Swaify, 1975).

3. Molokai soil

The stability diagram for the Molokai soil (Fig. 13C) is similar to that of the Waikane soil. Stable dispersions in distilled water were obtained at pH 3.4 and above. Increasing the electrolyte concentration from H₂O only to 0.01M KCl caused a gradual reduction in the turbidity of the samples, an effect which was not clearly observed with the previous soils. Further increase in electrolyte concentrations sharply reduced the turbidity and full flocculation was achieved even at the highest pH level in the presence of 1.0M KCl. As for the previous soils, increasing the electrolyte concentration required greater pH changes also before redispersion could be effected, although the extent of dispersion was somewhat reduced.

Fig. 13B. Colloidal stability diagram as a function of different concentrations of KCl and pH--Waikane soil.

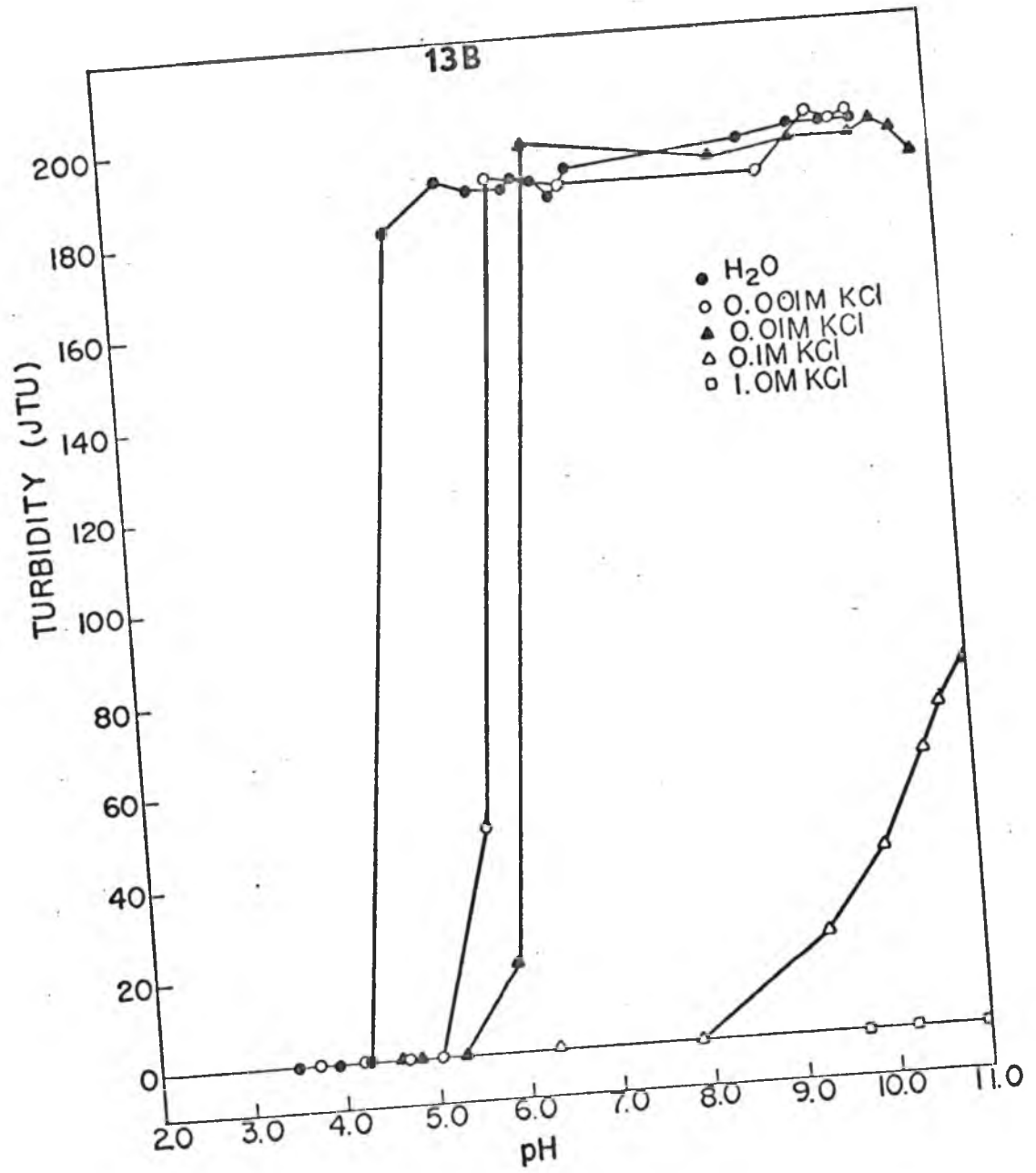
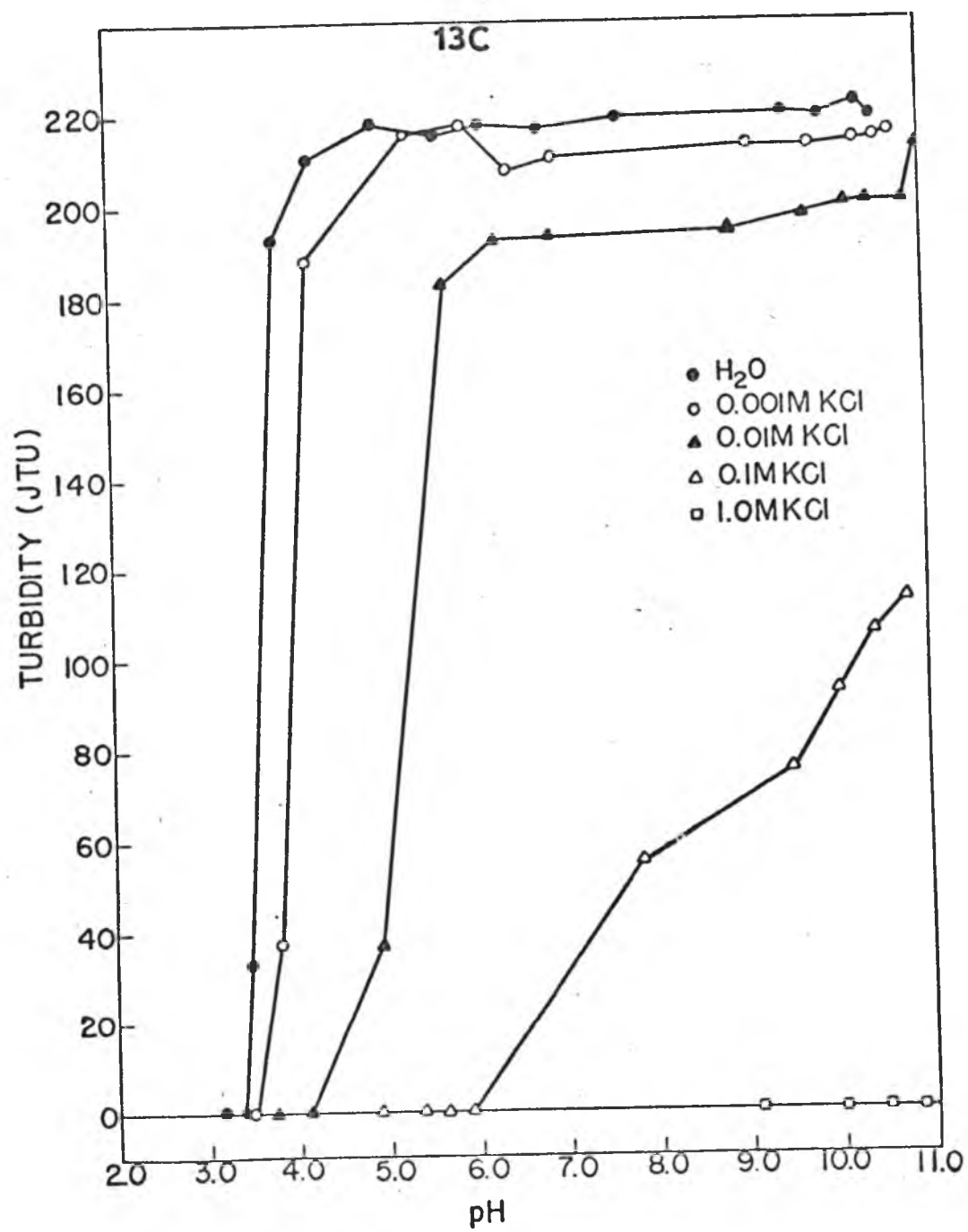

Fig. 13C. Colloidal stability diagram as a function of different concentrations of KCl and pH--Molokai soil.



The behavior of this soil reflects similar trends observed for pure kaolinite clay suspended in NaCl (El-Swaify, 1975).

E. Colloidal Stability - Discussions

The stability diagrams for each of the soils studied, are qualitatively related to the charge balance in the system as determined by the charge characteristics of its constituents. Thus the Hilo soil which is dominated by amphoteric constituents displayed a stability diagram which is characteristic of amphoteric systems. On the other hand the stability diagrams for the Waikane and Molokai soils showed characteristics indicating the influence of the 1:1 silicate clays (kaolinite in the case of Molokai, and halloysite in Waikane) as expected since they are the dominant colloids in these systems.

Examination of the stability data (Fig. 13A - 13C) in distilled water and low electrolyte concentrations ($10^{-3}M$ KCl) showed a linear dependence of the repulsive forces on pH changes only in the regions of transition from fully stable to fully flocculated systems. In this vicinity, the charge balance approach proposed by El-Swaify (1975) gave a reasonable approximation of the electrostatic energy of repulsion developed due to pH changes. Further increase in surface charge of the same sign did not materially increase the repulsive energy. This relationship was predicted by Verwey and Overbeek (1948). Equation(20) (Verwey and Overbeek (1948) showed that for large values of the surface potential, the electrostatic energy of repulsion is dependent only on interparticle distance and the quantity

K. In the case of the Hilo soil, since the surface potential and charge density of the majority of its constituents show similar dependences on pH and electrolyte concentration, the approximate equation (20) (Sect. C.1., Literature Review) gives a reasonable qualitative explanation of stability. A similar line of reasoning could also be applied to the Waikane and Molokai soils.

The effect of the quantity, K (equation (20)), on the repulsive energy is seen by the gradual increase in the flocculation region as the electrolyte concentration is increased. At very high concentrations, no dispersion could be effected even at the highest pH values. As mentioned previously, the effect of increasing electrolyte concentration is to compress the diffuse layer which ultimately reduces the energy of repulsion. Furthermore, the possibility of specific adsorption of K^+ or Cl^- in real soil systems could not be discounted entirely, therefore the potential at the OHP (Fig. 1), rather than the surface potential, may be the more appropriate quantity which determines the repulsive energy. Since the potential at the OHP is sensitive to electrolyte concentration (Sect. C.2., Literature Review), it is expected that increasing the latter not only compresses the diffuse layer, but also reduces the diffuse layer potential, ψ_δ . Thus while the surface potential increases with increasing pH, the diffuse layer potential could conceivably approach zero by increasing the electrolyte concentration. Consequently, the repulsive energy will be much lower than would be the case if it depended on the surface potential, ψ_0 . This seems to be a reasonable explanation of

the inability of colloids to disperse at high electrolyte concentrations even when the surface charge is considerably increased.

The flocculated region of the Hilo soil suspended in distilled water and in $10^{-3}M$ KCl lie between pH 7 and 8.5, and between pH 6.7 and 9.7, respectively. This region extends between the limits of the ZPC values for the major constituents found in this soil. Reported ZPC values were 7.8 to 9.5 for gibbsite (Hingston *et al.*, 1972), 6.4 for magnetite (Ahmed, 1969), and 6.1 - 8.5 for amorphous alumino-silicates (allophane) (Wada *et al.*, 1958; Limura, 1961), and around 8 for amorphous hydroxides (Parks, 1965). Organic matter presence contribute to some reduction of observed ZPC. Thus for this soil at least, the flocculation region in distilled water and low electrolyte concentrations is easily explained on the basis of the ZPC values of its constituents. The situation is, however, more complicated concerning the Waikane and Molokai soils. Reported ZPC values for kaolinite are anywhere from none (Toth, 1967) to 5.0 (Parks, 1967) and those for the oxides and hydroxides found in these soils lie between 7 and 9. There has been no reported ZPC values for halloysite, but it may be assumed to be within the range reported for kaolinite. The stability diagrams for the latter soils exhibited behaviors which were closer to that expected of a pure kaolinite system (see El-Swaify, 1975) than a mixture of 1:1 layer silicate and oxides, even though the clay:oxides ratios were less than 2:1 (Table 1). The above observations could not be explained adequately on the basis of the charge characteristics of the major constituents, nor the relative amounts of each colloid in the system.

It is possible that particle sizes (Princen et al., 1964) may have to be considered also. Studies on colloidal stability in pure kaolinite and hydroxide systems (El-Swaify, 1975) on the other hand definitely reflect the inherent contributions of the constituents in the system, even when the clay:hydroxide ratio was 10:1.

For reasons already stated (Sect. E., Literature Review) a full quantitative explanation of the relative effects of colloidal interactions on soil physical properties, using the concepts of colloidal stability is not possible. These concepts nevertheless provide the theoretical basis required to predict soil behavior even if the prediction is only qualitative in nature. The results obtained showed that colloidal stability or flocculation is determined by the electrochemical properties of the soil constituents. Stability or flocculation in distilled water and low electrolyte concentrations are adequately explained by the charge balance in the system which is in turn determined by the charge characteristics of the dominant colloids in the system. At high electrolyte concentrations, and, when specifically adsorbed ions are present (e.g. Ca^{2+} , SO_4^{2-}), the simplified charge balance approach may be inadequate, therefore the Stern treatment must be applied. In this instance the potential at the OHP rather than the surface potential determines the magnitude of the repulsive energy. Since under normal conditions, the total salt concentrations in soils rarely exceed 10^{-2}M , flocculation or dispersion of soil colloids and their subsequent responses in soil structure may be predicted with reasonable accuracy using the charge

balance approach. The applicability of this concept to practical soil problems is discussed in the following section.

F. Particle-Size Analysis - Results

Particle-size distribution is one of the most stable soil characteristics being little modified by cultivation or other practices. Knowledge of particle size distribution is valuable for predicting the interrelationships between chemical and physical soil behavior and practical problems such as susceptibility of soil to erosion by water or wind. In the United States, it is used as the basis for soil textural classification. For the purpose of this study, particle-size analysis provide a useful and simple test of the practical application of informations on the electrochemical properties of soil colloids. The results for each soil are presented for three particle size classes ($>50 \mu\text{m}$, $2 \mu\text{m} - 50 \mu\text{m}$, and $<2 \mu\text{m}$ particle diameters) as a function of pH.

1. Hilo soil

The percent clay (particle size $<2 \mu\text{m}$) remaining in suspension when plotted against pH (Fig. 14A) showed the same symmetrical feature observed in the stability diagram (Fig. 13A). A region of maximum dispersion (60-67% clay) was observed to occur at pH values of 5 and less, and a second region at pH values greater than 8, although the extent of dispersion in this second region was lower (46-54% clay). Between pH 6 and 8, the soil could not be dispersed. This behavior is predictable on the basis of the charge characteristics of this soil. The particle-size distributions at various pH values are reported in Table 4A.

Fig. 14A. Percent of less than 2 μm soil fractions remaining in suspension as a function of the pH at which dispersion was effected--Hilo soil.

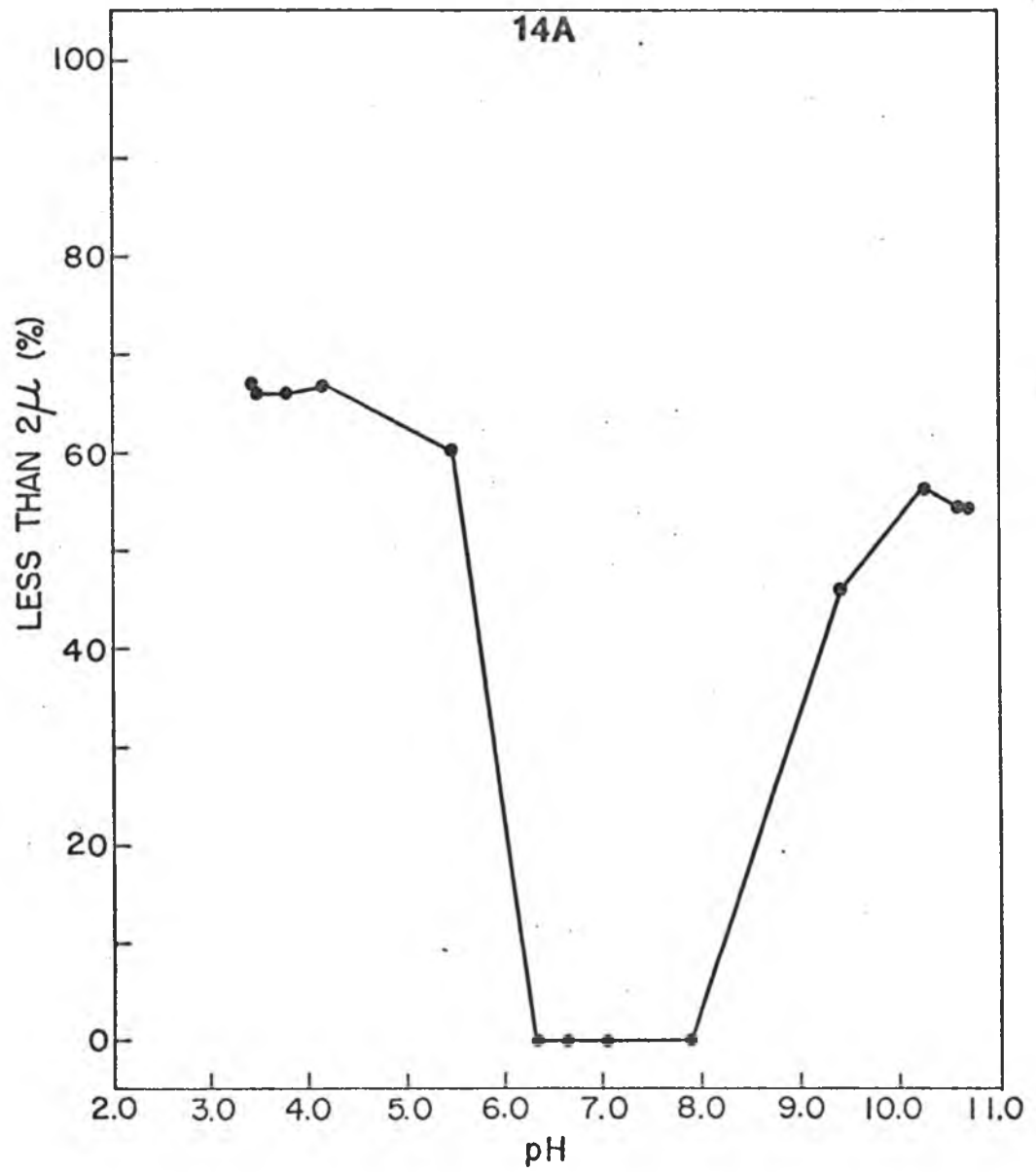

Table 4A. Particle-size distribution of the original soils dispersed at different pH values--Hilo soil

pH	Particle-size distribution (%)		
	Greater than 50 μm	2 - 50 μm	Less than 2 μm
3.43	20.1	13.1	66.8
3.50	22.2	12.0	65.8
3.77	21.6	12.2	66.2
4.15	19.6	13.4	67.0
5.46*	20.1*	19.4*	60.5*
6.34	23.4	76.6	0.0
6.66	22.8	77.2	0.0
7.03	23.5	76.5	0.0
7.91	24.2	75.8	0.0
9.40	24.4	29.4	46.2
10.25	21.9	21.6	56.5
10.61	23.2	22.4	54.4
10.70	21.0	24.8	54.2

*No acid (HCl) or base (NaOH) added.

2. Waikane soil

The per cent clay-pH curve for this soil (Fig. 14B) again showed trends very similar to those observed in the stability diagram (Fig. 13B). Dispersion of this soil was achieved only at pH values greater than 6, with the maximum observed to occur at pH 10 - 11 (82% clay). Below pH 5, the soil remained flocculated. As was the case for the Hilo soil, the behavior of this soil is readily explained by the nature of the surface charge-pH curves (Figs. 7B, 8B, 10B). The data on particle-size distribution (Table 4B) also indicate that under normal field conditions (pH 5.03) this soil is structurally, very stable.

3. Molokai soil

The behavior of the Molokai soil (Fig. 14C) is very much the same as that of the Waikane soil. It however, required slightly higher pH changes (pH 6.8) before dispersion could be effected with the maximum occurring at pH 10 - 11 (72-73% clay). It could not be dispersed at pH values lower than 6. The particle-size distribution at various pH values is reported in Table 4C. The data compares favorably with that of Matsusaka (1952), who dispersed the soil in $(\text{NH}_4)_2\text{CO}_3$ at pH 10.5. He reported having obtained 78.75% clay (<2 μm), 13.26% silt (2 μm - 50 μm), and 0.09% sand (>50 μm). Per cent clays as high as 79 has been reported by El-Swaify and co-workers (1968), by dispersing in a medium adjusted to pH 9.5 - 10 with sodium carbonate after removal of sesquioxides.

Fig. 14B. Percent of less than 2 μm soil fractions remaining in suspension as a function of the pH at which dispersion was effected--Waikane soil.

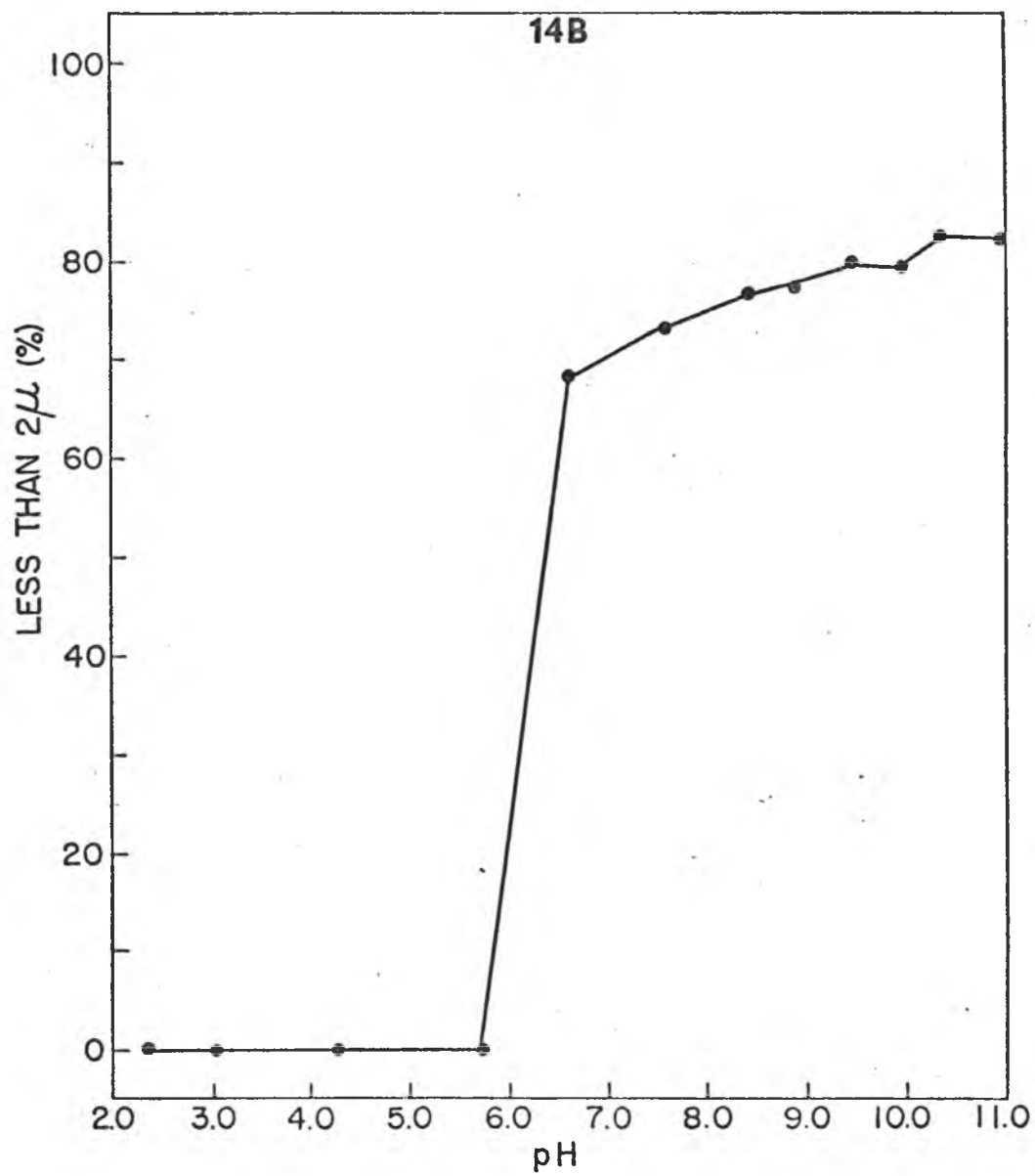

Table 4B. Particle-size distribution of the original soils dispersed at different pH values--Waikane soil

pH	Particle-size distribution (%)		
	Greater than 50 μm	2 - 50 μm	Less than 2 μm
2.36	4.2	95.8	0.0
3.04	5.1	94.9	0.0
4.30	5.1	94.9	0.0
5.76	5.4	94.6	0.0
5.93*	5.1*	94.9*	0.0*
6.59	4.6	27.4	68.0
7.58	3.7	23.0	73.3
8.43	3.6	19.9	76.5
8.90	3.2	19.8	77.0
9.46	3.0	16.8	80.2
9.98	3.1	17.8	79.1
10.35	3.1	14.9	82.4
10.99	3.0	15.0	82.0
11.28	3.1	15.4	81.6

*No acid (HCl) or base (NaOH) added.

Fig. 14C. Percent of less than 2 μm soil fractions remaining in suspension as a function of the pH at which dispersion was effected--Molokai soil.

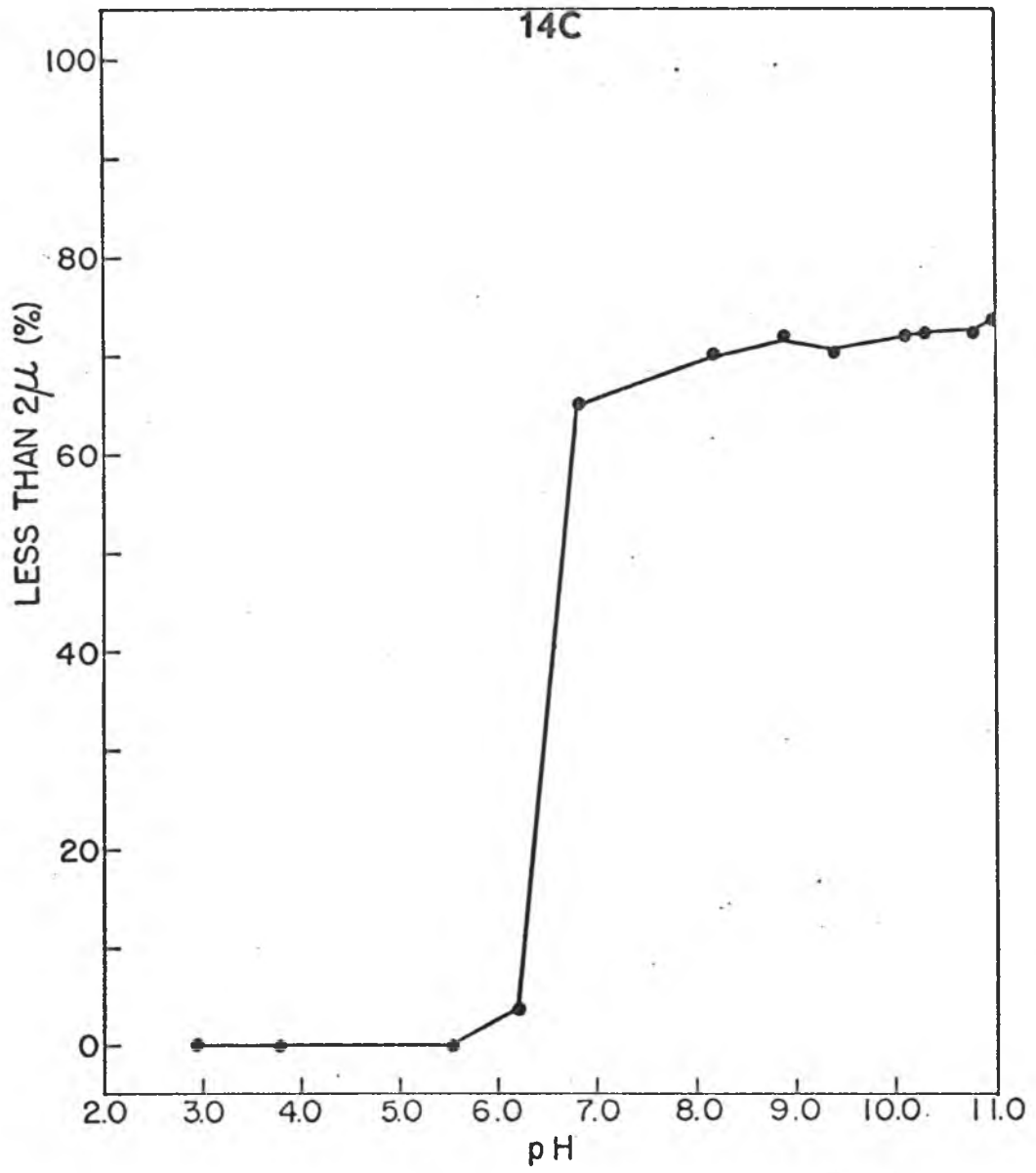

Table 4C. Particle-size distribution of the original soils dispersed at different pH values--Molokai soil

pH	Particle-size distribution (%)		
	Greater than 50 μm	2 - 50 μm	Less than 2 μm
2.96	5.0	95.0	0.0
3.83	5.1	94.9	0.0
5.56	5.5	94.5	0.0
6.24	5.5	91.3	3.2
6.81*	5.5*	29.1*	65.4*
8.18	5.0	24.5	70.5
8.89	4.8	22.8	72.4
9.42	5.0	25.0	70.0
10.10	5.0	23.2	71.8
10.29	5.0	23.1	71.9
10.78	4.8	23.4	71.6
11.00	5.0	21.1	73.9

*No acid (HCl) or base (NaOH) added.

G. Particle-Size Analysis - Discussions

1. Practical application of stability concepts

The per cent clay-pH curves for the three soils show a definite relationship between the charge characteristics of colloidal constituents (Sect. B.) and soil physical properties. This relationship was of course implied in the colloidal stability studies. The close similarities between stability diagrams and per cent clay recovered from natural soils at various pH values was most interesting considering that no pretreatment to remove soluble salts or organic matter was applied in the latter experiments. Deviations from the stability diagrams were observed as a slight broadening of the flocculation region. These deviations could have been caused by the natural presence of specifically adsorbed ions such as Ca^{2+} , Al^{3+} , and SO_4^{-2} , on the exchange complex and by the fact that ionic environments were not identical for the two experiments. Effects of natural multivalent ions on ψ_δ , and consequently the repulsive energy, have been discussed previously. However, even if these ions are present, the flocculation-dispersion behavior of these soils could be predicted with reasonable accuracy using the charge balance approach. One need to know only the charge characteristics of a given soil in order to predict the region in which dispersion or flocculation could be effected. For example, the symmetrical nature of the surface charge-pH curves for the Hilo soil predict the possibility of dispersing this soil in both the acid and alkaline pH ranges, a fact which was experimentally verified (Fig. 14A). On the other hand, the surface charge-pH curves for the Waikane and Molokai soils,

predict that dispersion could be effected only at high pH values (Figs. 14B and 14C).

Application of the charge balance approach to routine particle-size analysis may be simplified by using the ΔpH technique. The ΔpH value ($\text{pH}_{\text{KCl}} - \text{pH}_{\text{H}_2\text{O}}$) provides information on the sign of the surface charge at field conditions, that is, a negative value indicate net negative charges and vice versa. It also provides an estimate of the probable location of the ZPC (at the ZPC, $\Delta\text{pH} = 0$), and the pH in water provides an estimate of the probable pH region in which dispersion could be effected. For example, a pH reading of 4.5 in water, and a ΔpH value of -0.10 indicate a ZPC less than 4.5, therefore dispersion could best be achieved at much higher pH values. On the other hand, a ΔpH of +0.10 and a pH of 4.5 in water indicate a ZPC greater than 4.5, but no definite conclusion could be drawn as to the best pH region to disperse the soil. This would have to be determined by dispersing at $\text{pH} < 4.5$ and $\text{pH} > 4.5$. It must be understood of course that the ΔpH value is nothing more than a qualitative indicator of the net charge status of a given soil. Therefore it should not be used alone as an alternative to the more quantitative potentiometric titration method for determining the charge characteristics of soils.

2. Implications to practical agriculture

Other than providing information on the particle-size distributions of the three soils, the results presented have other perhaps more important implications regarding practical agricultural problems. Soil behavior under varying management conditions could

be predicted with reasonable accuracy when its charge characteristics are known. Thus for soils with mostly variable charge colloids, the most stable structure is expected to occur in the vicinity of the ZPC because maximum mutual flocculation between oppositely charged colloids occur at this point. As predicted by theory (Sect. C. - E., Literature Review) the flocculation region is not a point, but a relatively broad region. Within this region, soil physical properties such as aggregate stability and water infiltration and movement characteristics should be highly favorable. Consequently, soil resistance to erosion forces may be assumed to be highest. Beyond the ZPC, or flocculation region, structural deterioration will occur more easily which consequently result in poor physical properties and low resistance to erosion forces. The results presented indicated that the transition between good and poor soil structure is abrupt and that further increase in charges of similar sign do not increase structural deterioration greatly.

The effect of solution composition on structure, reflects the modifying influence of the ions on surface charge and the diffuse layer potential, ψ_δ . Thus the favorable effects of Ca^{2+} and Mg^{2+} on soil physical properties may be explained on the basis of their effects on reducing ψ_δ . The inability to reduce aggregate stability in oxidic soils with sodium (El-Swaify, 1970) on the other hand may indicate that the effect of pH on surface charge rather than the presence of sodium determines the magnitude of the repulsive forces. The effect of anions on hydraulic conductivity on some Hawaiian soils showed the Hilo soil to be the most sensitive to anion types in the

applied solutions (El-Swaify, 1973). The sulphate system in particular showed appreciable structural changes with increasing concentration, when the pH of the applied solution ranged from about 5 - 6. The results shown above (Fig. 14A) indicate that this soil is easily dispersed in this pH range. Specific adsorption of sulfate also caused the ZPC to shift to higher pH values thereby inducing more positive charges at pH 5 - 6 than did chloride ions, consequently double layer repulsion and dispersion follow.

For a given soil solution composition, the flocculation-dispersion behavior of soils with variable charges depend on soil pH. Depending on the charge characteristics of the soil, which in turn are determined by the electrochemical properties of the major constituents, liming may or may not improve structure. When the dominant colloids are 1:1 layer silicates, over-liming may cause structural deterioration. On the other hand soils, dominated by oxides and hydroxides of Al and Fe, and, amorphous silicates, may benefit structurally from liming.

In the discussions to this point, it may have become obvious that requirements necessary for favorable soil structure conflict with soil fertility requirements. It is obvious that cation exchange capacity, hence favorable fertility status and less nutrient losses by leaching, increases with increasing pH (net negative charge). For the Waikane and Molokai soils, raising the pH to increase cation exchange capacity will have deleterious effect on structure. On the other hand, for the Hilo soil, raising the pH not only increases cation exchange capacity, but it may also result in

more favorable structure. The most favorable structure for soils containing variable charge colloids is expected to occur at the ZPC, yet from the fertility standpoint it represents the maximum in ion retention, therefore soils which naturally exist close to their zero point of charge are generally considered to be infertile. In liming highly weathered soils, equal emphasis should be given to the consequences on fertility and structural aspects. This implies knowledge of the charge characteristics of these soils.

SUMMARY AND CONCLUSIONS

A study was conducted to determine the charge characteristics of three Hawaiian soils representing tropical Inceptisols, Ultisols, and Oxisols. Evidence of the influence of charge characteristics of soil colloidal constituents on the charge balance (net charge) was indicated by the differences in the surface charge-pH curves of the three soils. For each soil studied, the presence of specifically adsorbed ions such as Ca^{2+} and SO_4^{-2} , caused a noticeable shift in the zero point of charge (ZPC) to lower and higher pH values, respectively, relative to the ZPC in pure KCl systems. Analysis of possible reaction mechanisms revealed that the Ca^{2+} interaction with soil surfaces is highly dependent on the pH of the system whereas the SO_4^{-2} interaction with soil surfaces showed less dependence on pH. A saturation limit for the adsorption of Ca^{2+} and SO_4^{-2} was observed to occur when the concentration of the above ions in the supporting electrolyte reached 10^{-2}M . Furthermore, when both Ca^{2+} and SO_4^{-2} were simultaneously present in the supporting electrolyte, the resulting surface charge-pH curves reflected the influence of SO_4^{-2} more than of Ca^{2+} .

Studies on colloidal stability as a function of pH (surface charge) indicated a strong relationship between colloidal stability and surface charge. Because certain requirements could not be met in this study, a full quantitative explanation of the phenomenon of mutual flocculation was not carried out. Nevertheless, a qualitative explanation using the concepts of colloidal stability provided

a satisfactory interpretation of these observations. In real soil systems, the simplified charge balance approach proposed by El-Swaify (1975) is adequate for predicting soil flocculation-dispersion behavior.

As a practical application of the concepts of colloidal stability, particle-size analysis under varying pH levels was carried out on natural soils. The results obtained gave further evidence of the applicability of stability concepts to real soil systems. Several other implications to practical agriculture were also noted especially those related to soil structure. Since pH is a controllable variable, the effects of such practices as liming of soils were discussed. It was concluded that since soil pH (net charge) to a large extent determine the physical properties of soils with variable charge colloids, careful consideration should be given to the consequences of liming not only on the fertility but also on the structural property of these soils.

BIBLIOGRAPHY

1. Adamson, A. W. (1967). Physical chemistry of surfaces. 2nd. Ed. Interscience Pub., John Wiley and Sons, New York - London - Sydney.
2. Ahmed, S. M. (1969). Studies of the double layer at oxide-solution interface. *J. Phys. Chem.* 73:3546-3555.
3. _____ (1972). Electrical double layer at metal oxide-solution interfaces. In "Oxides and Oxide films." Vol. 1 of Anodic Behavior of Metals and Semi-conductors series. ed. J. W. Diggle. Marcel Dekker, Inc., New York.
4. _____, and Maksimov, D. (1968). Studies of the oxide surfaces at the liquid-solid interface. Part II. Fe oxides. *Can. J. Chem.* 46:3841-3846.
5. _____, and _____ (1969). Studies of the double layer on cassiterite and rutile. *J. Coll. Interface Sci.* 29:97-103.
6. Allison, L. E. (1965). Organic carbon. Ch. 90, In "Methods of Soil Analysis." ed. C. A. Black, Amer. Soc. Agron. Monograph No. 9, part 2. pp. 1372-1374.
7. Atkinson, R. J., Posner, A. M., and Quirk, J. P. (1967). Adsorption of potential-determining ions at the ferric oxide-aqueous electrolyte interface. *J. Phys. Chem.* 71:550-558.
8. Ayres, A. S., and Hagihara, H. H. (1953). Effect of anion on the sorption of potassium by some Humic and Hydrol Humic Latosols. *Soil Sci.* 75:1-17.
9. Barber, R. G., and Rewell, D. L. (1972). Charge distribution and the cation exchange capacity of an iron-rich kalionitic soil. *J. Soil Sci.* 23:135-146.
10. Berube, Y. G., and de Bruyn, P. L. (1968). Adsorption at the rutile-solution interface. I. Thermodynamic and experimental study. *J. Coll. Interface Sci.* 27:305-318.
11. Bijsterbosch, B. H., and Lyklema, J. (1965). Electrochemistry of silver iodide. Double layer properties in the presence of adsorbed organic molecules. *J. Coll. Sci.* 20:665-678.
12. Blackmore, A. V. (1973). Aggregation of clay by the products of iron hydrolysis. *Aust. J. Soil Res.* 11:75-82.

13. Bockris, J. O. M., Devanathan, M. A. V., and Müller, K. (1963). On the structure of charged interfaces. Roy. Soc. London Proc. Ser. A, 274:55-79.
14. Breeuwsma, A. (1973). Adsorption of ions on haematite (Fe_2O_3). Medelingen Landbouwhogeschool, Wageningen.
15. _____, and Lyklema, J. (1971). Interfacial electro-chemistry of haematite (Fe_2O_3). Disc. Faraday Soc. 52:324-333.
16. Chan, J. K. (1972). Chemical and morphological characterization of the noncrystalline fraction in the Hilo soil (Typic Hydrandepts). M.S. thesis, University of Hawaii.
17. Chesters, G., Attoe, O. J., and Allen, O. N. (1957). Soil aggregation in relation to various soil constituents. Soil Sci. Soc. Amer. Proc. 21:272-277.
18. Dangler, E. W. (1973). Comparative rheological behavior of suspended clays with varying ionic composition. Ph.D. thesis, University of Hawaii.
19. Delahay, P. (1966). Double layer and electrode kinetics. Interscience Pub., John Wiley and Sons, Inc., New York - London - Sydney.
20. Derjaguin, B. V. (1954). A theory of heterocoagulation, interaction and adhesion of dissimilar particles in solutions of electrolytes. Disc. Faraday Soc. 18:85-98.
21. _____, and Landau, L. (1941). Acta physicochim. URSS 14:633.
22. Desphande, T. L., Greenland, D. J., and Quirk, J. P. (1964). Role of iron oxides in the bonding of soil particles. Nature 201:107-108.
23. _____, _____, and _____ (1968). Changes in soil properties associated with the removal of iron and aluminum oxides. J. Soil Sci. 19:108-121.
24. Edelfsen, N. E., and Cole, R. C. (1963). A comparison of the specific gravity balance and the pipette methods of determining density of soil suspensions. Soil Sci. 42:131-137.
25. El-Swaify, S. A. (1969). Soil physical chemistry, notes for Soil Sci. 640, pp. 132-147. Dept. of Agron. and Soil Science, University of Hawaii.

26. El-Swaify, S. A. (1970). The stability of saturated soil aggregates in certain tropical soils as affected by solution composition. *Soil Sci.* 109:197-202.
27. _____ (1971). Charges associated with soil mineral components and their implications in tropical soil behavior. Univ. of Hawaii College of Tropical Agriculture Special Publication presented at the AID - 211 - D Workshop.
28. _____ (1973). Structural changes in tropical soils due to anions in irrigation water. *Soil Sci.* 115:64-72.
29. _____ (1975). Changes in the physical properties of soil clays due to precipitated aluminum and iron hydroxides. II. Colloidal interactions in the absence of drying. (To be submitted for publ. in *Soil Sci. Soc. Amer. Proc.*)
30. _____, and Emerson, W. W. (1975). Changes in the physical properties of soil clays due to precipitation of aluminum and iron hydroxides. I. Swelling and aggregate stability after drying. *Soil Sci. Soc. Amer. Proc.* (in press).
31. _____, and Sayegh, A. H. (1975). Charges on Oxisols and Inceptisols. *Soil Sci.* Vol. 120.
32. _____, Swindale, L. D., and Uehara, G. (1968). Salinity tolerances of certain tropical soils and relationships between sodium ion activities and soil physical properties. Hawaii Institute of Geophysics and Dept. Agron. and Soil Science, College of Trop. Agric., Univ. of Hawaii Report No. HIG - 68 - 12.
33. Fox, R. L. (1973). Chemistry and management of soils dominated by amorphous colloids. *Soil Crop Sci. Soc. Florida Proc.* 33:112-119.
34. Grahame, D. C. (1947). The electrical double layer and the theory of electrocapillarity. *Chem. Reviews* 41:441-501.
35. Greenland, D. J. (1965a). Interaction between clays and organic compounds in soils. Part I. Mechanisms of interaction between clays and defined organic compounds. *Soils Fert.* 28:415-425.
36. _____ (1965b). Interaction between clays and organic compounds in soils. Part II. Adsorption of soil organic compounds and its effect on soil properties. *Soils Fert.* 28:521-531.

37. Hasan, S. M., Fox, R. L., and Boyd, C. C. (1970). Solubility and availability of sorbed sulfate in Hawaiian soils. *Soil Sci. Soc. Amer. Proc.* 34:897-901.
38. Healy, T. W., Herring, A. P., and Fuerstenau, D. W. (1966). The effect of crystal structure on the surface properties of a series of manganese dioxides. *J. Coll. Interface Sci.* 21:435-444.
39. _____, Wiese, G. R., Yates, D. E., and Kavanagh, B. V. (1973). Heterocoagulation in mixed oxide colloidal dispersions. *J. Coll. Interface Sci.* 42:647-649.
40. Hingston, F. J., Atkinson, R. J., Posner, A. M., and Quirk, J. P. (1967). Specific adsorption of anions. *Nature* 215:1459-1461.
41. _____, _____, _____, and _____ (1968). Specific adsorption of anion on goethite. 9th Int. Cong. Soil Sci. Trans. Adelaide, Aust.
42. _____, _____, _____, and _____ (1972). Anion adsorption by goethite and gibbsite. I. The role of the proton in determining adsorption envelopes. *J. Soil Sci.* 23:177-192.
43. Hogg, R., Healy, T. W., and Fuerstenau, D. W. (1966). Mutual coagulation of colloidal dispersions. *Faraday Soc. Trans.* 62:1638-1651.
44. Honig, E. P., and Hengst, J. H. Th. (1969). The point of zero charge and solid state properties of silver bromide. *J. Coll. Interface Sci.* 31:545-556.
45. Hussain, A., and Kyuma, K. (1970). Charge characteristics of soil organo-mineral complexes and their effects on phosphate fixation. *Soil Sci. Plant Nutr.* 16:154-162.
46. Jones, R. C., and Uehara, G. (1974). Amorphous coatings on mineral surfaces. *Soil Sci. Soc. Amer. Proc.* 37:792-798.
47. Keng, J. C. W. (1974). Surface chemistry of some constant potential soil colloids. M.S. thesis, University of Hawaii.
48. _____, and Uehara, G. (1974). Chemistry, mineralogy, and taxonomy of Oxisols and Ultisols. *Soil and Crop Sci. Soc. Florida Proc.* 33:119-126.
49. Limura, K. (1961). Acidic property and ion exchange in allophane. *Clay Sci.* 1:28-32.

50. Lutz, J. F. (1936). The relation of free iron in the soil to aggregation. *Soil Sci. Soc. Amer. Proc.* 1:43-45.
51. Lyklema, J., and Overbeek, J. Th. G. (1961). The electrochemistry of silver iodide. The capacity of the double layer at the silver iodide-water interface. *J. Coll. Sci.* 16:595-608.
52. Mackor, E. L. (1951). The properties of the electrical double layer. *Recueil Des Travaux Chimiques Des Pays-Bas* 70:663-674, 747-783, 841-866.
53. Marshall, T. J. (1956). A plummet balance for measuring the size distribution of soil particles. *Aust. J. Applied Sci.* 7:142-147.
54. Martin, A. E., and Reeve, R. (1960a). Chemical studies of podzolic illuvial horizons. IV. The flocculation of humus by aluminum. *J. Soil Sci.* 11:369-381.
55. _____, and _____ (1960b). Chemical studies of podzolic illuvial horizons. V. Flocculation of humus by ferric and ferrous iron and by nickel. *J. Soil Sci.* 11:382-393.
56. Matsusaka, Y. (1952). Dehydration curves and differential thermal curves of clays from Hawaiian soils. M.S. thesis, University of Hawaii.
57. _____, and Sherman, G. D. (1950). Titration curves and buffering capacities of Hawaiian soils. *Hawaii Agric. Expt. Sta. Tech. Bull.* No. 11.
58. Mekar, T., and Uehara, G. (1972). Anion adsorption in ferruginous tropical soils. *Soil Sci. Soc. Amer. Proc.* 36:296-300.
59. Overbeek, J. Th. G. (1952). The electrochemistry of the double layer. In Kruyt, "Colloid Science." Vol. 1, Ch. IV. Elsevier Publ. Co., Amsterdam - Houston - New York - London.
60. Parks, G. A. (1965). The isoelectric points of solid oxides, solid hydroxides, and aqueous hydroxo complex systems. *Chem. Revs.* 65:177-198.
61. _____ (1967). Aqueous surface chemistry of oxides and complex oxide minerals. Isoelectric point and zero point of charge. *Adv. Chem. Series* 67:121-160.

62. Parks, G. A., and de Bruyn, P. L. (1962). The zero point of charge of oxides. *J. Phys. Chem.* 66:967-973.
63. Princen, L. H., and De Vena-Peplinski, Marilyn (1964). Effect of particle size on the mutual flocculation between zinc oxide and titanium oxide. *J. Coll. Sci.* 19:786-797.
64. Pugh, R. J., and Kitchener, J. A. (1971). Theory of selective coagulation in mixed colloidal suspensions. *J. Coll. Interface Sci.* 35:656-664.
65. _____, and _____ (1972). Experimental confirmation of selective coagulation in mixed colloidal suspensions. *J. Coll. Interface Sci.* 38:656-657.
66. Robertson, H. S., Brindley, G. W., and Mackenzie, R. C. (1954). Mineralogy of Kaolin clays from Pugu, Tanganyika. *Am. Mineralogist* 39:118-139.
67. Robinson, M., Pask, J. A., and Fuerstenau, D. W. (1964). Surface charge of alumina and magnesia in aqueous media. *J. Amer. Cer. Soc.* 47:516-520.
68. Schofield, R. K. (1949). Effect of pH on electric charges carried by clay particles. *J. Soil Sci.* 1:1-8.
69. _____, and Samson, H. R. (1954). Flocculation of kaolinite due to a attraction of oppositely charged crystal faces. *Disc. Faraday Soc.* 18:135-220.
70. Sonntag, H., and Strenge, K. (1972). Coagulation and stability of disperse systems. Trans. by R. Kondor. Israel Program for Scientific Translations. Jerusalem - London. Halsted Press. New York.
71. Stoop, W. A. (1974). Interactions between phosphate adsorption and cation adsorption by soils and implications for plant nutrition. Ph.D. Dissertation, University of Hawaii.
72. Summer, M. E. (1963). Effect of iron oxides on positive and negative charges in clays and soils. *Clay Mineral Bull.* 29:218-226.
73. _____, and Reeves, N. G. (1966). The effect of iron oxide impurities on the positive and negative adsorption of chloride by kaolinites. *J. Soil Sci.* 17:274-279.
74. Tadros, TH. F., and Lyklema, J. (1969). The electrical double layer on silica in the presence of bivalent counter-ions. *J. Electroanal. Chem. Interfacial Electrochem.* 22:1-7.

75. Tamura, T. (1952). Latosols: Mineral allocation and content. Ph.D. Dissertation, University of Wisconsin.
76. Tweneboah, C. K., Greenland, D. J., and Oades, J. M. (1967). Changes in charge characteristics of soils after treatment with 0.5M calcium chloride at pH 1.5. Aust. J. Soil Res. 5:247-261.
77. Toth, S. J. (1967). The physical chemistry of soils. In "Chemistry of the Soil." 2nd. Ed. ed. F. E. Bear. Amer. Chem. Soc. Monograph Series No. 160. Reinhold Pub. Corp., New York - Amsterdam - London.
78. van Olphen, H. (1963). "An introduction to clay colloid chemistry." Interscience Publ., John Wiley and Sons, New York - London.
79. Van Raij, B., and Peech, M. (1972). Electrochemical properties of some Oxisols and Alfisols of the tropics. Soil Sci. Soc. Amer. Proc. 36:587-593.
80. Verwey, E. J. W., and Overbeek, J. Th. G. (1948). Theory of the stability of lyophobic colloids. Elsevier Publ. Co., Inc., New York - Amsterdam - London - Brussels.
81. Wada, K., and Ataka, H. (1958). The ion uptake mechanism of allophane. Soil and Plant Food 4:12-18.
82. Yaibuathes, N. (1969). Comparative studies of Oxidic horizons. M.S. thesis, University of Hawaii.
83. Yopps, J. A., and Fuerstenau, D. W. (1964). The zero point of charge of alpha-alumina. J. Coll. Sci. 19:61-71.