

Decision Support System for Development of Current and Future
Accessory Dwelling Units: A Bottom-up Approach to Affordable
Housing

ADARCH PROJECT SUBMITTED TO THE GRADUATE DIVISION OF THE
UNIVERSITY OF HAWAII AT MĀNOA IN PARTIAL FULFILLMENT OF THE
REQUIREMENTS FOR THE DEGREE OF

DOCTOR OF ARCHITECTURE

MAY 2017

By

Christian Simafranca

DArch Committee:

Hyoung-June Park, Chairperson
James Dator
Glenn Miyasato

Keywords: Housing, Support System, Design, Affordable Housing

LIST OF TABLES

Table 2.1	15
Table 3.1	35
Table 7.1	85
Table 7.2	90
Table 7.3	92
Table 7.4	92
Table 8.1	107
Table 8.2	146
Table 9.1	148
Table 9.2	150
Table 9.3	151
Table 9.4	151
Table 9.5	176
Table 10.1	178
Table 10.2	179
Table 10.3	181
Table 10.4	186
Table 10.5	188
Table 11.1	199
Table 11.2	202
Table 11.3	205

LIST OF FIGURES

Figure 2.1	15
Figure 3.1	26
Figure 3.2	28
Figure 3.3	29
Figure 3.4	32
Figure 3.5	34
Figure 3.6	36
Figure 3.7	38
Figure 4.1	46
Figure 4.2	49
Figure 4.3	51
Figure 4.4	56
Figure 4.5	57
Figure 5.1	60
Figure 5.2	60
Figure 5.3	61
Figure 5.4	64
Figure 5.5	67
Figure 5.6	67
Figure 5.7	68
Figure 6.1	72
Figure 6.2	74
Figure 6.3	80
Figure 6.4	81
Figure 7.1	84
Figure 7.2	87
Figure 7.3	93
Figure 7.4	94
Figure 7.5	96
Figure 7.6	98
Figure 7.7	100

Figure 7.8	103
Figure 8.1	106
Figure 8.2	108
Figure 8.3	111
Figure 8.4	112
Figure 8.5	114
Figure 8.6	116
Figure 8.7	119
Figure 8.8	120
Figure 8.9	121
Figure 8.10	122
Figure 8.11	123
Figure 8.12	124
Figure 8.13	126
Figure 8.14	127
Figure 8.15	128
Figure 8.16	129
Figure 8.17	131
Figure 8.18	133
Figure 8.19	135
Figure 8.20	138
Figure 8.21	139
Figure 8.22	141
Figure 8.23	143
Figure 8.24	144
Figure 8.25	144
Figure 9.1	147
Figure 9.2	148
Figure 9.3	150
Figure 9.4	152
Figure 9.5	155
Figure 9.6	156
Figure 9.7	157
Figure 9.8	159

Figure 9.9	161
Figure 9.10	162
Figure 9.11	163
Figure 9.12	164
Figure 9.13	165
Figure 9.14	167
Figure 9.15	170
Figure 9.16	171
Figure 9.17	172
Figure 9.18	173
Figure 9.19	174
Figure 10.1	177
Figure 10.2	179
Figure 10.3	183
Figure 10.4	184
Figure 10.5	185
Figure 10.6	186
Figure 10.7	187
Figure 10.8	189
Figure 10.9	190
Figure 10.10	191
Figure 10.11	192
Figure 10.12	193
Figure 10.13	194
Figure 10.14	195
Figure 10.15	196
Figure 11.1	198
Figure 11.2	198
Figure 11.3	207
Figure 11.4	208
Figure 11.5	208

TABLE OF CONTENTS

ABSTRACT	10
CHAPTER 1 INTRODUCTION	11
CHAPTER 2 : HAWAII HOUSING PROBLEMS	13
CHAPTER 3 : ADU PRESENT ISSUES	22
ILLEGAL ALTERNATIVE	22
INADEQUATE INFRASTRUCTURE	24
SITE SUITABILITY	30
LONG PERMIT WAITS	35
LOW-COST DESIGN	39
CHAPTER 4 : ADU FUTURE ISSUES.....	43
INDEPENDENT WASTEWATER	43
ALTERNATIVE TRANSPORTATION.....	47
RENEWABLE ENERGY	53
DECENTRALIZED CONSTRCUTION.....	54
CHAPTER 5 : PRECEDENT STUDIES	59
AHL ONE PERCENT PRO BONO ADU.....	59
OHANA KIT	62
SANTA CRUZ ADU PROGRAM	65
MICRO COMPACT HOUSE	69
CHAPTER 6 : SUPPORT SYSTEM DESIGN LENSES.....	71
VIEW/VISTA	75
ACCESSIBLITY/EGRESS.....	76
VENTILATION.....	78
STRUCTURE	79
PRIVACY.....	82
COST.....	82

LIGHTING.....	83
CHAPTER 7 : PRE-DESIGN.....	84
PRE-CHECK	85
GENERAL COST ASSESSMENT	88
LIST OF DESIRED SPACES	91
PROPERTY IDENTIFICATION	93
IDENTIFY PHYSICAL PROPERTY FEATURES.....	94
IDENTIFY LOGICSTICAL PROPERTY FEATURES.....	96
SPACE ANALYSIS.....	98
ADU TYPE SELECTION	100
CHAPTER 8 : DESIGN WORKFLOW FOR A DETACHED ADU	106
ADU PLACEMENT	108
EXISTING FEATURE CONFLICT PLANNING.....	111
PLACEMENT REFINEMENT	112
BUILDING ORIENTATION PLANNING.....	114
INTERNAL DIVISION ANALYSIS	116
INTERNAL LAYOUT PLANNING	119
INTERNAL LAYOUT REFINEMENT	120
IDENTIFY NECESSARY COMPONENTS	121
KITCHEN COMPONENT LAYOUT	122
BATHROOM COMPONENT LAYOUT	126
BEDROOM COMPONENT LAYOUT	128
LIVING ROOM COMPONENT LAYOUT	129
DOOR AND CIRCULATION PLANNING.....	131
LAYOUT REFINEMENT	133
WINDOW PLANNING	135
ROOF SPAN ANALYSIS.....	138

BUILDING SECTION.....	139
ROOF PITCH DETERMINATION.....	141
SECTION REFINEMENT	143
CONSTRUCTION SYSTEMS APPLICATION.....	144
CONCEPTUAL MATERIAL TAKEOFF.....	145
CHAPTER 9 : DESIGN WORKFLOW FOR AN ATTACHED MODIFIED ADU.....	147
EXISTING SPACE ANALYSIS	148
EXISTING SPACE STRATEGY	150
INTERNAL DIVISION ANALYSIS	152
INTERNAL LAYOUT PLAN	155
INTERNAL LAYOUT REFINEMENT	156
IDENTIFY NECESSARY COMPONENTS	157
KITCHEN COMPONENT LAYOUT	159
BATHROOM COMPONENT LAYOUT	161
BEDROOM COMPONENT LAYOUT	162
LIVING ROOM COMPONENT LAYOUT	163
DOOR AND CIRCULATION PLANNING.....	164
LAYOUT REFINEMENT	165
WINDOW PLANNING	167
ROOF SPAN ANALYSIS.....	170
BUILDING SECTION.....	171
SECTION REFINEMENT	172
CONSTRUCTION SYSTEMS APPLICATION.....	173
CONCEPTUAL MATERIAL TAKEOFF.....	175
CHAPTER 10 : OTHER DESIGN CONSIDERATIONS	177
AESTHETIC CONSIDERATIONS	177
DESIGN FOR FUTURE ADUS.....	182

CHAPTER 11 : DESIGN ANALYSIS.....	197
DETACHED ADU COST ANALYSIS.....	199
ATTACHED MODIFIED COST ANALYSIS	202
COST COMPARISON	204
FULL COSTS IN ADU DEVELOPMENT	205
PROCESS ANALYSIS AND EXPANSION.....	206
CONCLUSION.....	209
BIBLIOGRAPHY	210

ABSTRACT

In 2015 the state passed Ordinance 15-41 which allowed homeowners to develop Accessory Dwelling Units (ADUs), however, Hawai`i homeowners remain uninformed and ill-equipped in the means to develop and design an ADU. In acting as a developer the homeowner needs a system that can assist them in an ADU development project. This research develops an ADU Decision Support System which identifies a step-by-step procedure to generate a conceptual design for an ADU in a normative fashion. Furthermore, the support system provides the homeowner with a means to assess and modify their design before engaging a design professional. As a proactive measure, the system provides future considerations regarding wastewater, transportation, energy, and construction. Lastly, the support system has the potential for expansion to a web interface connecting willing and able ADU developers to eager design professionals. By informing and empowering the homeowner, this research can address statewide affordable housing issues.

CHAPTER 1 INTRODUCTION

Affordable housing in Hawai`i is a major problem. While residents try to find a cost-effective home to live and thrive in, they wonder where their children and aging parents will live. The state of Hawaii is the eighth smallest state yet has 1.4 million residents within 393 square miles of dense urban area.¹ Further compounding the issue is the high cost of housing compared to the low level of income. Additionally, there is a strong presence of outside real estate investment and non-local property ownership. Thus a predicament exists in finding affordable housing for local residents.

In 2015, Kirk Caldwell, Mayor of the City and County of Honolulu, passed a law which enabled homeowners to construct of Accessory Dwelling Units (ADUs) on their property provided that they complied with specific requirements. An ADU is a small dwelling unit that can be attached or detached from the primary residence with all of the amenities of a standard single family home. This unit can either used by the homeowner or rented out for additional income existing income.² This law has significant potential to impact Hawaii's affordable housing shortage. As the Honolulu County is the most populated of the five counties in the state, addressing issues of affordable housing in Honolulu can create the biggest impact on reducing stresses on affordable housing supply.

Homeowners, however, are slow adopters to the new regulation. According to the Star-Advertiser, as of March 2016, only seven ADU's were issued since September 2015 when the ADU law passed. As a result, the state adopted an additional law in March 2016 to create an economic incentive for homeowners to build ADUs. This law waives up to \$10,000 in sewer charges and other fees for the construction of ADU's.³ Although this new law is a step towards incentivizing ADU construction, it omits the means by which an average homeowner can design the ADU or determine as to whether the ADU is a worthwhile investment of time and resources.

¹ DBEDT, "Urban and Rural Areas in the State of Hawaii, by County:2010," (Research and Economic Analysis Division, 2013).

² *Relating to Accessory Dwelling Units*, 20.

³ "Consider Waiving Adu Fees to Boost Affordable Housing," *Staradvertiser* 2016.

Homeowners need a support system to help them navigate the journey towards the development of an ADU. This research seeks to break down a decision-making process necessary to design and develop an ADU in a way that is usable by homeowners and designers alike. While there are off-the-shelf alternatives to designing one's own ADU, this research encompasses the embraces the whole creative process. The goal is to empower the individual to develop an ADU personalized to his or her specific needs, rather than utilizing a predefined model.

CHAPTER 2 : HAWAII HOUSING PROBLEMS

In the State of Hawaii, there are five counties: Hawaii County, Honolulu County, Maui County, Kauai County, and Kalawao County.⁴ Of these five counties, the Honolulu County has the greatest population estimated at 998,714 residents.⁵ Honolulu County is the home of the Honolulu International Airport, the Hawaii State Capitol, the downtown business district, and Waikiki. Marketed as a tropical paradise, Honolulu County is actually an urban center with an ongoing affordable housing crisis.⁶ In the American Community Survey, conducted in 2015 by the Census Bureau, Honolulu County has approximately 344,075 housing units.⁷ Within the state there are 309,602 households with approximately 3.06 persons per household.⁸ The housing problem is exacerbated further when the issues of affordability and available space are applied.

According to a housing demand analysis published March 2015 by the State of Hawaii's Department of Business, Economic Development, & Tourism (DBEDT), there is a demand for affordable housing, particularly rental properties. The report estimates that Hawaii needs an additional 64,700 to 66,000 housing units for 2015 to 2025. The report also projects the population growth by county. DBEDT predicts:

- Honolulu County's population will grow 8% needing an additional 25,847 units.
- Hawaii County's population will grow 29% needing an additional 19,610 units.
- Maui County's population will grow 25% needing an additional 13,949 units.
- Kauai County's population will grow 19% needing an additional 5,287 units.

Although Honolulu County is only expected to grow 8%, the number of additional housing units needed is significantly greater than the other counties.⁹

⁴ Sheila Beal, "Hawaii Fact 6 of 50: Hawaii Has 5 Counties,"

<http://www.govisithawaii.com/2009/07/08/hawaii-fact-6-of-50-hawaii-has-5-counties/>.

⁵ 2015 American Community Survey 1-Year Estimates U.S. Census Bureau, "Total Population," (2015).

⁶ City and County of Honolulu, "Housing Oahu: Affordable Housing Strategy," (2015).

⁷ 2015 American Community Survey 1-Year Estimates U.S. Census Bureau, "Housing Units," (2015).

⁸ "Quickfacts, Honolulu County, Hawaii," (U.S. Census Bureau, 2015).

⁹ DBEDT, "Measuring Housing Demand in Hawaii, 2015-2025," (Department of Business Economic Development and Tourism, 2015).

In addition to the need for more housing units, the Affordable Rental Housing Study Update of 2014 estimates by 2020 Hawai'i needs an additional 27,200 affordable rental units statewide. Honolulu County, alone, needs 14,008 of those units. The study ranks Hawai'i first in overcrowding, measured by any room occupied by more than one individual.¹⁰ Overcrowding has health and safety implications. In Hawai'i, overcrowding is a defense against homelessness.¹¹

In the Affordable Housing Strategy Report published by the City and County of Honolulu, the report predicts that over 75% of the projected housing demand for the county needs to be "affordable." Affordable defined as less than 80% of the county's area mean income or \$76,650 for a four-person family.¹² Another study by Coldwell Banker, a national real estate brokerage, found the average listing price for a four-bedroom home in Hawai'i was \$905,954 in 2016. In Honolulu County, the average price for a four-bedroom home was \$1.2 million, ranking 14th in the nation in 2016.¹³ When the state's minimum wage is \$9.25 beginning in 2017¹⁴, and the 2015 average mean non-family household income is \$58,591,¹⁵ it is no wonder the Affordable Housing Strategy Report claims the residents of Hawai'i spend up to 45% of their earned income on housing and transportation costs.¹⁶ In Hawai'i, it is nearly impossible for a minimum wage earner to get by without multiple jobs or assistance from family members or roommates.

The limited space available in the Honolulu County is a problem as well. Since volcanic activity shaped the Hawaiian Islands, their topology is far from planar. The mountainous and unbuildable areas account for a significant portion of land in the county. Of the buildable land, the urban land area accounts for 219 square miles with a population of 945,000 people while the rural land area accounts for 382 square miles with a population

¹⁰ Rick Cassidy, "Honolulu Rental Market Affordable Rental Housing Study Update, 2014," (2014).

¹¹ Honolulu, "Housing Oahu: Affordable Housing Strategy."

¹² Ibid.

¹³ HNN, "Hawaii Has Highest Average List Price for Homes, but Bargains to Be Found in Some Places," <http://www.hawaiinewsnow.com/story/30495509/state-tops-list-for-average-housing-list-price-but-bargains-to-be-found-in-some-communities>.

¹⁴ State of Hawaii Wage Standards Division, "Minimum Wage and Overtime," <http://labor.hawaii.gov/wsd/minimum-wage/>.

¹⁵ 2015 American Community Survey 1-Year Estimates U.S. Census Bureau, "Income in the Past 12 Months (in 2015 Inflation-Adjusted Dollars)," (2015).

¹⁶ Honolulu, "Housing Oahu: Affordable Housing Strategy."

of 8,200 people.¹⁷ Further reducing the limited amount of buildable space in Honolulu County is a surprising amount of suburban sprawl type planned communities such as Mililani Town, Ocean Pointe, Coral Ridge by Gentry, Parkside by Gentry, Sunterra, Koa Ridge, Ka Makana at Hoakalei, and Ho'opili to name a few. These communities spread out horizontally rather than featuring denser vertical development. Some of these developments even contain a large track of land dedicated to a lofty attached golf course.

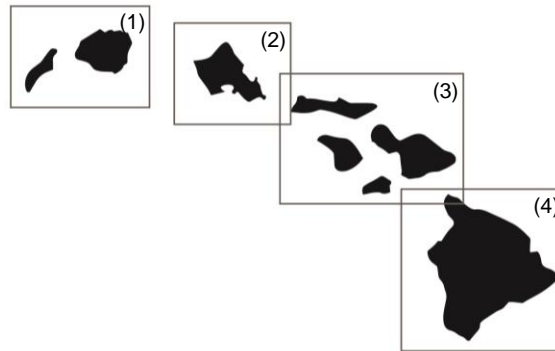

Figure 2.1- Diagram illustrating major counties in the State of Hawaii.

Table 2.1 - Table compiling state housing and income data arranged by county.

	Kauai County (1)	Honolulu County (2)	Maui County (3)	Hawaii County (4)
Population	71,735 ^A	998,174 ^A	164,593 ^A	196,428 ^A
Housing	30,467 units ^A	374,075 units ^A	71,712 units ^A	86,023 units ^A
Housing Demand	5,287 units ^B	25,847 units ^B	13,949 units ^B	19,610 units ^B
Rural Area	584 sq. mi. ^C	382 sq. mi. ^C	1122 sq. mi. ^C	3,942 sq. mi. ^C
Urban Area	36 sq. mi. ^C	219 sq. mi. ^C	52 sq. mi. ^C	87 sq. mi. ^C
Mean Income	\$88,364 ^A	\$98,463 ^A	\$86,558 ^A	\$70,160 ^A
Median Income	\$77,140 ^A	\$77,273 ^A	\$70,497 ^A	\$60,033 ^A
^A Data from 2015 American Community Survey 1-year estimates ^B Data from DBEDT Measuring Housing Demand in Hawaii, 2015-2025 ^C Data from DBEDT Urban and Rural Areas Report, 2010				

The need for affordable housing is evident. The problem remains how to deal with the issue. "High housing costs and low incomes is clearly the primary contributor to

¹⁷ DBEDT, "Urban and Rural Areas in the State of Hawaii, by County:2010."

affordable housing shortages.”¹⁸ The State must either find a way to improve the capabilities of the lower income earner or find a way to produce more affordable housing supply. Building affordable housing projects are unprofitable to developers. They require public funds and assistance.¹⁹ The affordable housing requirement tries to force developers to build affordable housing units. It imposes a rule in which about 20% of housing units within a housing project must be affordable. This requirement means the price for a for-sale unit can be no more than 120% of the area mean income (AMI) of the State. A rental unit must rent for no more than 80% AMI.²⁰ This type of approach to affordable housing still leaves out much of the minimum wage earning demographic. Meanwhile, the remaining 80% of housing projects can be at a full market rate and well beyond the affordability of most Hawai’i residents. “Relative to what has been supplied, the number of rental units affordable to those making 80% (and 60%, and 50%, and 30% of AMI), the supply/demand imbalance is tremendous, in quantitative terms.”²¹

The Affordable Housing Strategy Report outlines a few key methods for addressing the housing issue: Transit Oriented Development (TOD), Accessory Dwelling Units (ADUs), and financial incentives.²² Of these options, the ADUs have the immediate potential to leverage crowdsourcing and achieve a collective goal of affordable housing for the state. The other two require long-range planning and implementation to realize. TOD projects are dependent upon the completion of the Honolulu Rail Project, an ongoing federal project building the first high-speed rail in the State of Hawaii. The rail project is facing a multitude of setbacks, the least of which is funding. It has no completion date in sight as planners contemplate various options to secure funding for the project.²³ ADUs have the potential to be a major component of the housing agenda if homeowners can be encouraged to build ADUs. The report claims that there may be up to 100,000 eligible homeowners and the law has the potential to assist in providing approximately 250

¹⁸ Cassidy, "Honolulu Rental Market Affordable Rental Housing Study Update, 2014."

¹⁹ Ibid.

²⁰ Honolulu, "Housing Oahu: Affordable Housing Strategy."

²¹ Cassidy, "Honolulu Rental Market Affordable Rental Housing Study Update, 2014."

²² Honolulu, "Housing Oahu: Affordable Housing Strategy."

²³ Scott Wilson, "How to Save Money and Salvage the Rail," (2017), <http://www.civilbeat.org/2017/03/how-to-save-money-and-salvage-the-rail/>.

housing units per year.²⁴ Issues of affordable housing are not new but rather the ADU regulation provides a new opportunity to address the ongoing problem.

In 1982, Ordinance 82-44 passed which outlined a means to allow for “Ohana Units” in the zoning code. The “Ohana Unit” is essentially a second dwelling unit on a single property. This law was put in place to assist Hawaii residents in providing affordable housing for the extended family.²⁵ According to an article in USA Today, Hawaii had the largest share of multigenerational families in the nation in 2012.²⁶ Costs of living and housing are expensive and grandparents, parents, children, and sometimes even great-grandparents live together as a means to avoid the costs of another household. Since 1982, the State has been looking for a solution to its affordable housing problem as evidenced by the outdated ordinance.

Following the passing of the “Ohana Unit” law, Ordinance 88-48 passed which placed limitations on the permitting of these new dwelling units. There were growing concerns as developers were using the new law as a loophole to create Condominium Property Regime (CPR) units. CPR units are two or more condominium units that share common elements. Developers were utilizing the “Ohana Unit” law to take areas zoned for single family housing and develop CPRs and then sell them off as a second single family home.²⁷ Ordinance 88-48 limited the size of the new “Ohana Unit” based on the size of the proposed lot.²⁸

After prolific abuse of the “Ohana Unit” regulations, the State banned further approval of these units. In 1989 the city passed Ordinance 89-155 which made it impossible to pursue “Ohana Units.”²⁹ The ordinance place a moratorium on the issuance of “Ohana Unit” permits. It would be another four years before the State finally allowed the

²⁴ Honolulu, "Housing Oahu: Affordable Housing Strategy."

²⁵ "Luo Amendment 2015 - a Council Initiated Proposal Related to Adus," (2015).

²⁶ Haya El Nasser, "More Multigenerational Families in Immigrant Areas," (2012), <http://www.usatoday.com/story/news/nation/2012/10/25/census-multigenerational-households/1653159/>.

²⁷ Questor Lau, "Black Boxes and Gray Spaces: How Illegal Accessory Dwelling Find Regulatory Loopholes" (University of Hawaii, 2014).

²⁸ "Luo Amendment 2015 - a Council Initiated Proposal Related to Adus."

²⁹ Ibid.

reissuing of permits for these dwellings. In the meantime, new regulations were added to make it difficult to abuse the law moving forward. The new regulations include:

- The permission to build “Ohana Units” on agricultural lots
- The restricted use to conforming lots
- The restricted occupancy exclusively by a family member
- The prohibition of the units use as a condominium
- A bailout option for neighbors to opt out of the Ohana zoning eligibility
- A requirement that the new unit must be an attachment to the existing house.³⁰

The requirements implemented in Ordinance 89-155 made it very difficult to pursue the “Ohana Unit.” At the time, widespread implementation of “Ohana Units” was not realized as an effective solution to providing affordable housing.³¹

In 2014, Tom Dinell, an Emeritus Professor of Urban and Regional Planning at the University of Hawaii at Manoa, identified “Ohana Units” as a legitimate solution to the affordable housing problem. Professor Dinell also identified two roadblocks are preventing “Ohana Unit” from succeeding in the housing problem:

The fastest and most efficient way to increase the stock of affordable housing in Honolulu is staring us right in the face, and we don't see it. It is 'ohana housing (sometimes referred to as accessory dwelling units or granny suites).

Honolulu officialdom not only does not welcome this opportunity, but puts roadblocks in the way. The most discouraging roadblock is that legally an 'ohana unit can only be for immediate family. That is a ridiculous requirement when 'ohana housing offers the possibility of adding thousands of rental units to our inadequate housing stock and at minimal cost to government.

The second unnecessary legal requirement in Honolulu is that the 'ohana unit must be attached to or entirely contained within the main

³⁰ Ibid.

³¹ Ibid.

*house. That may or may not be the best configuration depending on the site in question.*³²

Because the law required the “Ohana Unit” be occupied by a relative and made it impossible to rent the space out to non-family members.³³ This requirement becomes problematic if a family no longer needed an additional dwelling space. If a grandparent passed away or a child moved out on their own, the parents would be left an abandoned “Ohana Unit.” Furthermore, a potential affordable housing unit could not be used to provide housing for other residents.

The forced attachment of the unit to the existing building also prevented homeowners from building “Ohana Units” on challenging sites that may have ample space. There may be numerous reasons why attaching the unit would not be advantageous to the homeowner. Some reasons include conflicts with existing features, conflicts with existing property boundaries, unsuitable land, and foundation conditions, existing easements, etc. Because of these reasons, many homeowners forego the legal construction of an “Ohana Unit” and turn instead to illegitimate methods to construct an “Ohana Unit” as demonstrated by Mr. Questor Lau.

In 2014, Mr. Questor Lau identified the Rec Room Loophole in his Doctorate of Architecture Dissertation, *Black Boxes, and Gray Spaces: How Illegal Accessory Dwellings Find Regulatory Loopholes*. This research identified the use of a recreation room permit to create illegal dwelling units. The recreation room has far fewer requirements than the “Ohana Unit” and can be outfitted with the necessary services including sewer, water supply, and electricity because a wet bar is allowed in the recreation room. Provided a full kitchen was not installed, the recreational room would pass inspection. Homeowners would permit and build a recreation room and then illegally use it as a secondary dwelling.³⁴ The illegal ADU is still a problem with recreational room permits. The ADU law takes steps in remedying the situation.

³² Tom Dinell, "Affordable Housing the 'Ohana Way," (2014).

³³ "Luo Amendment 2015 - a Council Initiated Proposal Related to Adus."

³⁴ Lau, "Black Boxes and Gray Spaces: How Illegal Accessory Dwelling Find Regulatory Loopholes".

The ADU, Ordinance 15-41, was passed in September 2015 by Mayor Kirk Caldwell.³⁵ This new law is an upgrade to the previous Ohana housing law and outlines specific requirements for the permitting and construction of ADUs based on zoning and implemented features. Additionally, the new law no longer requires the occupant of the ADU to be a relative nor does it require the ADU to be attached to the existing dwelling.³⁶ The new ADU law now allows the accessory unit to be used for either an extra family home or a rental property, helping to alleviate the housing needs of residents.

Building an ADU, however, can be a daunting experience for homeowners who experiences unexpected fees. Development projects require some up-front capital to deal with such requirements as sewer fees, administrative fees, permitting fees, etc. As of mid-March 2016, there were only seven ADU permits issued in the six-month period that the ADU law was in effect. The sewer hookup fee for a new ADU alone is about \$6000.³⁷ These additional costs were unclear and unexpected by homeowners applying for ADU construction. The State passed another law, Ordinance 16-19, which temporarily waived fees up to \$10,000 in the pursuit of an ADU for a two-year period.³⁸ The State hopes by removing excessive fees; homeowners will be incentivized to construct ADUs and help provide affordable housing inventory.

The passing of the ADU law and the incentive bill are a start to addressing affordable housing. However, like the Ohana law, the ADU law is filled with complex requirements which remain unclear to the average homeowner. Through the ADU law, the burden of affordable housing development has, in part, shifted to the homeowners of the State of Hawaii. The average homeowner, however, is ill-equipped to make the decision of whether to pursue the design and development of an ADU. Property developers, designers, and builders are individuals trained to developing the property, often with many years of experience under their belt. Their experiences in the field help them navigate the administrative and legal hoops of the building process. This research investigates a decision support system that will equip the homeowner with an awareness of critical decisions affecting the design and development of an ADU before needing

³⁵ *Relating to Accessory Dwelling Units.*

³⁶ *Ibid.*

³⁷ "Consider Waiving Adu Fees to Boost Affordable Housing."

³⁸ *Relating to Incentives for Accessory Dwelling Units Production, 27.*

expertise services. The goal is a decision support system that will provide the homeowner with a clear step by step workflow process to achieve their conceptual design for their own ADU. It is through this workflow that homeowners will be able to make an informed decision on whether to pursue an ADU or not. Through the empowerment of the homeowner, there is a significant potential to reinforce affordable housing supply in the State.

CHAPTER 3 : ADU PRESENT ISSUES

Addressing ADUs in the present is essential to tackling problems with affordable housing. If ADUs are a much-needed solution to affordable housing, why are there no significant improvements to the affordable housing problem since the ADU law passed? In short, many issues are surfacing as a consequence of the passing Ordinance 15-41. These matters include dealing with the illegal recreational room alternative, the lack of adequate supporting infrastructure for the homeowner's build process, the lack of clear site suitability maps, the extended permit waiting periods, and the lack of accessible public information for homeowners pursuing low-cost development. This chapter will provide insight into each of these areas while providing a response to managing these obstacles.

ILLEGAL ALTERNATIVE

The first issue regarding ADUs is that homeowners have already found an illegal loophole to abuse rather than following the legal route to accessory dwelling construction. In Mr. Questor Lau's dissertation, he identifies the "Rec Room Loophole" which allows homeowners the ability to build an accessory structure that has the capabilities to be used as a dwelling without following the strict requirements imposed by the ADU law. Provided the homeowners sign the affidavit which says they will not use the space as a dwelling, the homeowners can get approval for construction. Some homeowners are then using their new "recreational room" as a separate residence and renting it out. There are fines to face if caught renting out a "recreational room," but those costs are negligible compared to the passive income of a rental property.³⁹

The problem is the loophole is not closed yet and is a much simpler means to a necessary and potentially lucrative end. The ADU law passing in 2015, however, creates a legal means for homeowners to pursue an accessory dwelling unit and avoid fines. This law allows private homeowners to provide themselves with rental income and at the same time provide rental stock for the State of Hawai'i. What is unclear is if the net benefits gained through the legal process outweighs the net benefits obtained through

³⁹ "Black Boxes and Gray Spaces: How Illegal Accessory Dwelling Find Regulatory Loopholes".

the illegal approach. In the short run, the illegal method is advantageous as it dodges the rules and restrictions enforced by the legal path. But in the long-term, unforeseen costs may exist.

Whenever the property appraisal process comes into play, for example, if the property is put up for sale or refinanced, the illegal accessory dwelling unit property is at risk. An evaluation is needed to assess the market value of the building and site in comparison to comparable properties. When dealing with properties with unpermitted work, the process becomes more complicated as Randy Prothero, principal broker of EXP Realty, explains, "Unpermitted work may affect the value of the home or even your ability to sell it in the future." Furthermore, when selling a property with unpermitted work, the owner may have to pursue an after-the-fact building permit or spend large sums to bring the structure up to code. Randy continues to elaborate:

- State and tax departments may be unaware of the improvements as they do not show up on public record.
- Insurance may not cover unpermitted improvements.
- Valuation of the home may decrease as appraisers omit the areas improved.
- Mortgage lenders may choose to not lend to the property owner or may reduce the property value of the home.
- Buyers may be weary of taking on the liability of a property with unpermitted improvements.
- As building codes change the unpermitted work may become outdated making the process of obtaining an after-the-fact permit very difficult. In some cases the owner may have to tear down these illegal improvements.
- The property may be harder to sell.⁴⁰

Through the ADU law the State has provided a legal method to build an additional dwelling. Thus it may be less beneficial to pursue an illegal alternative when considering potential problems in the future, especially since an after-the-fact building permit costs double the price of a regular permit.⁴¹ Many homeowners mistakenly assume their home will stay in the family forever. This thinking is especially true amongst

⁴⁰ Randy Prothero, "Far Too Many Homes on Oahu Are Missing Building Permits," <http://hawaiiandy.net/post/3813663/get-a-contractor-and-get-the-permits--->.

⁴¹ June Watanabe, "Building Permit Fees Grow If Work Is Already Complete," (2015), <http://www.pressreader.com/usa/honolulu-star-advertiser/20150520/281883001926578>.

with multigenerational households in Hawai'i. The future, however, is unpredictable. No one can foresee the circumstances of future generations. The children or even grandchildren may move on to bigger and better things, like a big job promotion that requires moving to the mainland U.S., or hard times may hit, and the family must sell the house. Regardless of the circumstances, having to sell a home during a crucial life changing event is not the ideal time to find out there are issues that hinder the sale of the unit. A problem that potentially could occur is that the owner may have to sell the property at a loss if the illegal accessory dwelling reduces the property's value.

The short-term solution to the problem of the illegal accessory dwelling unit is to inform potential illegal ADU builders that there are unseen consequences of not following the proper regulatory process, especially since one exists. A long-term solution is to provide the homeowner with a Decision Support System that allows them to get through the design issues while following the requirements, quickly and efficiently and with as little up-front investment as possible. The ease of the legal alternative can then overshadow the benefits of sneaking an illegal dwelling through a construction loophole.

INADEQUATE INFRASTRUCTURE

A large issue in the development of ADUs is the lack of adequate infrastructure. Present infrastructure issues include lack of wastewater capacity, lack of roadway capacity, and lack of water supply. The City and County of Honolulu Land Use Ordinance (LUO) states that "[i]t is intended that accessory dwelling units only be allowed in areas where wastewater, water supply, and transportation facilities are adequate to support the additional dwelling units."⁴² Hawaii's infrastructure is in need of constant updating. Currently, there are areas of Honolulu County with deficiencies that have prevented some ADU developers. Unfortunately, infrastructure issues are not something homeowners can solve by themselves which leaves them at the mercy of the City and County. These issues can be problematic and disheartening to potential ADU developers.

⁴² *Relating to Accessory Dwelling Units.*

Lack of wastewater capacity is something many homeowners do not expect to prevent their construction plans. As of a Kitz4 News article in March 2017, the state denied some 268 ADU applications due to lack of sewer capacity. If there is not enough sewer capacity, proposed projects will have to wait until there is adequate infrastructure. According to an article in Kitz4 News, “[s]ewer hookups in older neighborhoods like Pauoa are the reason why close to 300 applicants were turned down.”⁴³ However, it is still hopeful as many projects did get approved as well. But, regarding those who were denied, how long do ADU developers have to wait?” This delay is something homeowners would like to know. They would also like to know what areas have adequate wastewater capacity so homeowners in those areas can decide if development is a possibility for them.

In an article published by Pacific Business News, Nathan Toothman of Bear Engineering, which deals chiefly with wastewater engineering, stated that sewer capacity is a primary component is preventing the ADU initiative. He claims that other individual alternatives to the use of the public sewer system are available, but the current regulations are too restrictive and make it difficult to implement such systems in an urban setting.⁴⁴

The Hawaii Administrative Rules, Section 11-62 defines a protocol for both public and independent sewer systems. It states that “[a]ll buildings used or occupied as a dwelling, all public buildings, and all buildings and places of assembly generating wastewater or with toilets, sinks, drains, or other plumbing fixtures capable of conveying waste water, shall be connected to a waste water system.” Buildings and places “..located within or near an available public sewer system as determined by the director, shall connect to the public sewer.”⁴⁵ The legalize in this section law prohibits the use of an independent system if within proximity to a public sewer line despite the whether or not such infrastructure has the capacity to support new construction. A property may have the conditions and the technology to implement individual systems and bypass the infrastructure issue, but due to the law, it is not possible. The lack of adequate

⁴³ Catherine Cruz, "Sewer Hookups Slow Accessory Dwelling Unit Approvals," (2017), <http://www.kitv.com/story/34680754/sewer-hookups-slow-accessory-dwelling-unit-approvals>.

⁴⁴ Tina Yuen, "There Is More to Hawaii's Sewer Problem Than Just the Pipes," (2016).

⁴⁵ "Wastewater Systems," ed. Department of Health, Hawaii Administrative Rules (2016).

infrastructure is problematic and there are many potential areas within the system where possible failures can occur.

Following the route effluent takes after leaving the fixture, the waste enters a public network of sanitation pipes. These pipes may travel directly to the treatment plant or take an intermediate step along its route at a pump station. The pump station will provide the effluent with enough pressure to complete its journey to the treatment plant. Once at the desired location the effluent is divided into solids and liquids through a sedimentation process. The liquid component then proceeds to treatment where it is subject to various filtration and chemical treatment processes. The liquid effluent is eventually treated to an environmentally safe level and discharged into the ocean far offshore. The solid waste is compressed and taken to the landfill.⁴⁶ Waste treatment is a complex process with many steps and procedures, all of which pose potential areas for inadequacies and put a cap on new development. For instance, if the storage and treatment tanks at the wastewater plant cannot support additional capacity or the pipes or pump station cannot support additional capacity then new developments will likely be denied.

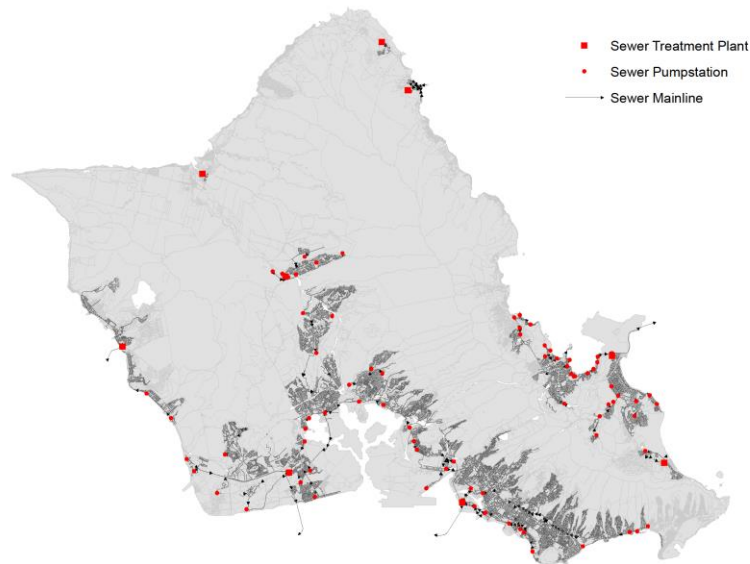

Figure 3.1- Geospatial map depicting the island wide public sewer system

Steve Kelly, vice-president at James Campbell Company, a national real estate firm with close ties to Hawaii, states that “The cost of building new or upsizing existing

⁴⁶ Department of Environmental Services, "Wastewater 101," (2010).

infrastructure is the single biggest impediment to building more affordable housing on Oahu.” He notes that “infrastructure improvements typically account for 20 to 35 percent of the cost of a new home.”⁴⁷ A homeowner may not be aware of such additional costs at the onset of an ADU development project. Further, the average homeowner may not have the extra funds to dedicate towards the upsizing of infrastructure. How is the average homeowner expected to develop ADUs while being uninformed about the infrastructure that is to serve the ADU?

The Honolulu Civil Beat notes that ADU development cannot proceed until the issue of sewer capacity gets resolved.⁴⁸ The ADU law itself is not the obstacle stopping the effort of affordable housing but rather the city sewer system is. The ADU law has the potential to significantly reinforce the amount of housing stock as it further densifies low-density development areas. But without wastewater infrastructure, ADUs are not a possibility.

An article in Pacific Business News discusses how there are two entities, Department of Planning and Permitting (DPP) and the Department of Environmental Services (DES), that currently have the ability to assess the sewer capacity at a location. The DES deals with the sewers and has the most updated information regarding the status of the infrastructure while DPP takes care of the permit involving wastewater approval. DES claims that they are uninformed about the needs of the state and require more time to plan accordingly. This article shines a light on the bureaucracy that further complicates issues regarding the problem of providing adequate sewer infrastructure. Figure 3.2 depicts a process developers go through when facing issues sewer capacity issues. “Developers generate plans to meet the increasing housing demand, their projects are often halted before they even break ground.”⁴⁹

⁴⁷ Yuen, "There Is More to Hawaii's Sewer Problem Than Just the Pipes."

⁴⁸ Anita Hofschneider, "How Crappy Sewers Make It Hard to Build Housing in Honolulu," (2015), <http://www.civilbeat.org/2015/11/how-crappy-sewers-make-it-hard-to-build-housing-in-honolulu/>.

⁴⁹ Yuen, "There Is More to Hawaii's Sewer Problem Than Just the Pipes."

THE SEWAGE DILEMMA

Sewers are complex places. They twist and turn underneath the streets of the city. The process to get a permit to connect to them is just as complicated and require some knowledge about the city's departments and their technology.

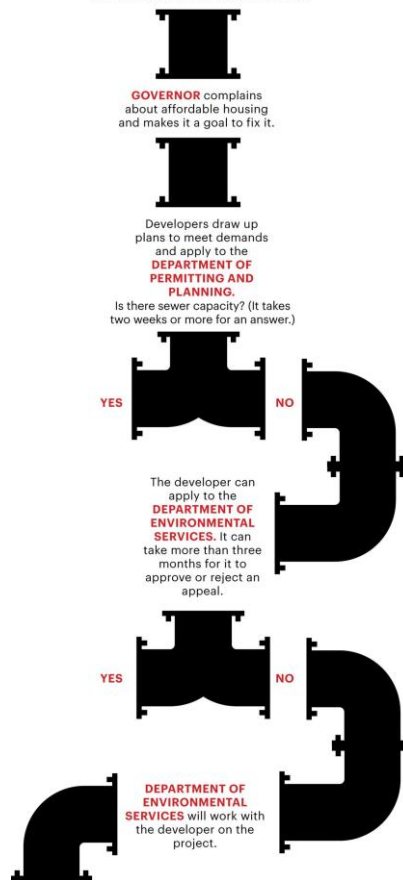

Figure 3.2- Diagram depicting sequence of steps to address wastewater capacity at a specific site.⁵⁰

Though the DPP must grant sewer capacity permits in many areas, a preliminary check may provide some level of insight into the issue. The Ohana zoned area is an indicator of properties that the Board of Water Supply (BWS) and Wastewater Management Department outline as locations with a high likeliness to have both water supply and sewer capacity. There are areas within the Ohana zone that have no sewer system but upon approval by the Department of Health may implement a septic system.⁵¹ The Ohana zone was originally intended to indicate areas where Ohana units could be suitable. The ADU law acts as a revision to the Ohana law, and therefore the Ohana zone can be a partial indicator of suitability regarding infrastructure. For homeowners

⁵⁰ Ibid.

⁵¹ City and County of Honolulu, "Ohana Zoning," (CCH GIS Data Dictionary).

who own properties within the Ohana zone area, it is likely that sewer and water supply will not be an issue.

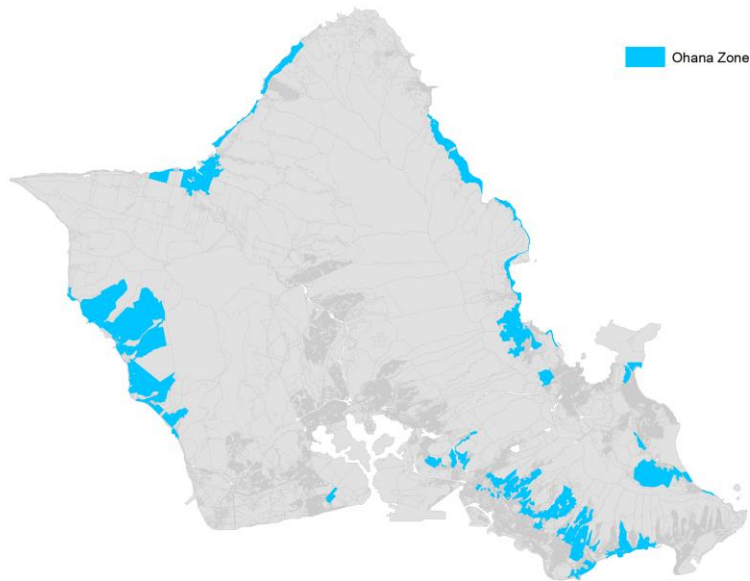

Figure 3.3- Geospatial map depicting Ohana Zone areas

Despite lacking sewer capacity, water supply does not seem to be a primary concern regarding ADU construction. As previously mentioned, areas within the Ohana zone will likely have water supply. Further, in the KITV4 news article mentioned earlier, the Honolulu BWS has said that they have yet to deny any homeowner pursuing a hookup for an ADU out of the 300 or so applications submitted as of March 2017. The news story claims that sewer is an issue but water supply does not seem to be a major problem in ADU development.⁵²

The final point regarding infrastructure and the development of ADUs is transportation. An ADU must gain approval by the Traffic Review Branch at the DPP.⁵³ In an article by Hawaii Renovation put out by the StarAdvertiser, there are homeowners being denied an ADU permit as a result of not having the minimum paved roadway access. Minimally a road of 20 feet or 18 feet, if serving up to six lots, is required.⁵⁴

⁵² Cruz, "Sewer Hookups Slow Accessory Dwelling Unit Approvals."

⁵³ "Accessory Dwelling Units (Adu) Recommended Public Facilities Pre-Check Form," ed. Department of Planning and Permitting (2016).

⁵⁴ "Maximizing Space with Adus," Graham Builders, <http://hawaiiinnovation.staradvertiser.com/2016/02/remodel/maximizing-space-adus/>.

Numerous infrastructure related problems prevent homeowners from acquiring an ADU permit. It is any wonder, so many permits fall through because of infrastructure problems. Additionally, many homeowners are frustrated when denied permission for ADU construction because of inadequate infrastructure, especially if they have already invested money and effort in the project. As infrastructure is not a burden of the homeowner, the state needs to adequately provide the necessary infrastructure promptly or provide the owner with an alternative option. As a present solution, the owner simply needs to be able to navigate the obstacles and determine early in the design stage if an ADU is worth pursuing before investing. As a future consideration, the homeowner should be provided with information and choices so that he or she is not disempowered but liberated to pursue an option that is most beneficial for his or her circumstance.

SITE SUITABILITY

The issue of site suitability deals with the logistical requirements imposed by the Land Use Ordinance (LUO) and regulations attached to the property itself. Similar to the Ohana ordinance, ADUs must conform to certain specific criteria. The ADU law prohibits the construction of an ADU on any lot other than R-3.5, R-5, R-7.5, R-10, R-20, and Country District lots. It also requires that lots pursuing an ADU must be at a minimum of 3500 square feet. Lots 3500 square feet to 4999 square feet can construct an ADU with a maximum floor area of 400 square feet. Lots that are 5000 square feet and above can build an ADU with a maximum floor area of 800 square feet. Further, the total built size of both the existing building combined with the area of the new ADU cannot exceed 50% of the total property size.⁵⁵ These basic requirements assure that ADUs get built on lots that are appropriately zoned and ensure that the land does not become overbuilt due to a new ADU structure.

According to the City Plan, all properties have a zone designation.⁵⁶ This designation for a particular lot can be determined by examining a property house plan, going online and

⁵⁵ *Relating to Accessory Dwelling Units.*

⁵⁶ City and County of Honolulu, "Chapter 21: Land Use Ordinance," in *Revised Ordinances of Honolulu.*

using the Department of Permitting and Planning (DPP) Property Search Tool⁵⁷, or contacting the DPP directly.

The purpose of the LUO is to regulate land use in a manner that will encourage orderly development by adopted land use policies, including the Oahu general plan and development plans, and to promote and protect the public health, safety, and welfare by, more particularly:

(1) Minimizing adverse effects resulting from the inappropriate location, use or design of sites and structures;

(2) Conserving the city's natural, historic and scenic resources and encouraging design which enhances the physical form of the city; and

(3) Assisting the public in identifying and understanding regulations affecting the development and use of land.⁵⁸

If a property in question does not have the necessary zoning designation for the intended purpose, one can pursue a variance to change the zoning.⁵⁹ Otherwise, the homeowner will not be allowed to build an ADU on the particular property.

The property zoning designation "R" signifies a residential property. "The purpose of the residential district is to allow for a range of residential densities."⁶⁰ The R-3.5, R-5, and R-7.5 designations indicated properties zoned for small to medium sized residential development. The R-10 and R-20 designation signify large sized residential development. ADUs pursued on "R" properties won't have any problem regarding zoning. However, such properties will still be subject to other restrictions

ADUs are also allowed on lots zoned as "Country" district.

⁵⁷ "Property Search," Department of Permitting and Planning, <http://dppweb.honolulu.gov/DPPWeb/Default.aspx?PossePresentation=PropertySearch>.

⁵⁸ Honolulu, "Chapter 21: Land Use Ordinance."

⁵⁹ Ibid.

⁶⁰ Ibid.

The purpose of the Country district is to recognize and provide for areas with limited potential for agricultural activities where the open space or rural quality of agricultural lands is desired. The district is intended to provide for some agricultural uses, low-density residential development, and some supporting services and uses.⁶¹

Unlike the agricultural, “AG,” designation the “Country” district is intended to support low-density residential use. There does, however, seem to be some conflict as owners of “AG” designated lots to try to pursue ADUs. In the county of Kauai, ordinance 981 passed in 2014 which extended the period for homeowners of lots designated “AG” to pursue ADUs.⁶² As there are numerous large plots with “AG” designation, some of which are in pursuit of ADUs, it may be worth considering a reevaluation of “AG” land on the periphery of residential development. These areas may be worth converting to “Country” district. One may try to apply for a variance in such a condition. Currently, however, only “Country” district properties can pursue an ADU.

Table 21-3.2
Residential Districts
Development Standards

Development Standard		District				
		R-3.5	R-5	R-7.5	R-10	R-20
Minimum lot area (square feet)	One-family dwelling, detached, and other uses	3,500	5,000	7,500	10,000	20,000
	Two-family dwelling, detached	7,000	7,500	14,000	[Use not permitted] 15,000	[Use not permitted] 25,000
	Duplex	3,500	3,750	7,000	[Use not permitted] 7,500	[Use not permitted] 12,500
Minimum lot width and depth (feet)		30 per duplex unit, 50 for other uses		35 per duplex unit, 65 for other uses	65 for dwellings, 100 for other uses	100
Yards (feet):	Front	10 for dwellings, 30 for other uses				
	Side and rear	5 for dwellings ¹ , 15 for other uses			5 for dwellings ¹ , 15 for other uses	
Maximum building area		50 percent of the zoning lot				
Maximum height (feet) ²		25-30				
Height setbacks		per Sec. 21-3.70-1(c)				

¹ For duplex lots, 5 feet for any portion of any structure not located on the common property line; the required side yard is zero feet for that portion of the lot containing the common wall.

² Heights above the minima of the given range may require height setbacks or may be subject to other requirements. See the appropriate section for the zoning district for additional development standards concerning height.

Figure 3.4- Development standards for accessory dwelling units⁶³

⁶¹ Ibid.

⁶² *Relating to Additional Dwelling Unit on Other Than Residentially Zone Lots*, Bill 2545.

⁶³ *Relating to Accessory Dwelling Units*.

The last and unexpected component to site suitability is the issue of Conditions, Covenants, and Restrictions (CC&R). In the State of Hawai'i, there are many planned communities and suburban developments. These communities often have a Home Owner Associations (HOA) which create regulations that the homeowners must follow or risk facing fines or even being foreclosed upon.⁶⁴ The CC&R may restrict complete fee simple use of the property by prohibiting certain construction and external modification in an attempt to maintain a neighborhood character. Regulations enforced by HOA can be problematic for homeowners who are in pursuit of an ADU.

In Mililani, the state denied many homeowners seeking the construction of an ADU due to the restrictions of the Mililani Town Association. The Mililani Town Association covers 16,000 homes under its regulatory umbrella. These properties are not able to pursue an ADU despite meeting the other ADU requirements. A change to the HOA bylaw would require 75% of the constituents to vote towards the modification. Realistically, acquiring the decisive vote would be unlikely.⁶⁵

Similarly, in Kahala, restrictive covenants exist on the properties dating back to the original leases established by Bishop Estate. These restrictions may be unknown to current homeowners and catch the homeowners off guard when pursuing an ADU. This frustration would be especially true if an unwary owner invested time and effort in developing an ADU and then realize post-haste that they were unable to implement their plans.⁶⁶

Many of these types of communities exist in Honolulu County encompassing large tracts of land. Other examples of HOA-governed communities include Ocean Pointe, Ewa by Gentry, Coral Ridge, Cypress Point, Villages of Kapolei, etc. Homeowners within these types of communities should look into their association bylaws and investigate the specifics regarding new construction. Their communities may prohibit ADUs. There are associations that do allow ADU construction so checking the association's bylaws is

⁶⁴ "What You Need to Know About Homeowners Associations in Hawaii," (2012), <http://www.hawaiilife.com/articles/2012/03/homeowners-associations/>.

⁶⁵ HNN, "Many Oahu Homeowners Will Not Be Able to Build Adus," <http://www.hawaiinewsnow.com/story/30083330/many-homeowners-will-not-be-able-to-build-adus>.

⁶⁶ Ian Lind to iLind, 2015.

worth the investigation. Currently, a compiled map noting the location of all boundaries governed by homeowners associations does not exist and it would be helpful in determining suitability for ADUs. Maintaining the integrity of the suburban community is the goal of HOA regulations. While it may be questionable if a suburban sprawl typology is the best use for Hawaii's limited landscape, homeowners buy into these communities and pay association dues to be part of a spacious and collective community. The problem arises when a homeowner later wants to individually pursue an ADU, breaking the integrity of the collective association. In planned communities, ADU construction must battle suburban development rules.

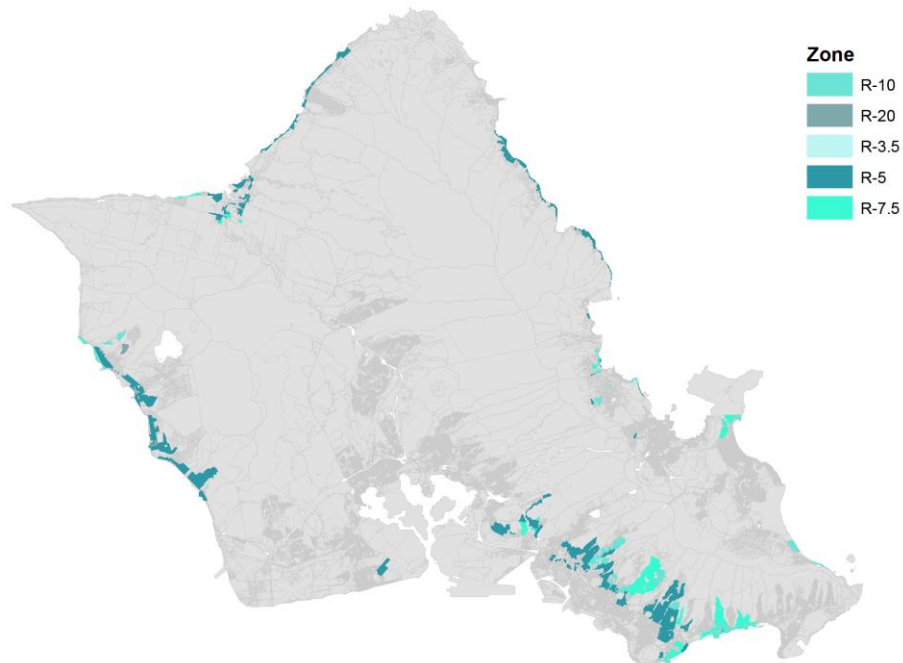

Figure 3.5- Geospatial composite map depicting potentially eligible areas that are within the Ohana Zone, meet the size requirements, and meet the zoning requirements for ADU development

Strict property requirements apply to the construction of ADUs. Similar to the issue of infrastructure, a property's zoning and size may complicate whether a property qualifies to develop an ADU. What homeowners need is a clear step-by-step workflow that provides a method to discover if his or her property is eligible for ADU construction. Armed with this information, an owner can decide early on whether to pursue an ADU or not. As a future consideration, a computerized system or composite map of relevant areas may be a faster more efficient way to allow the homeowner to make decisions regarding the development of an ADU.

LONG PERMIT WAITS

The ADU development process is also plagued with long permit waiting periods.⁶⁷ Professionals in the building industry understand the time needed to get a permit reviewed and approved and planned accordingly. The average homeowner, who is now substituting for an affordable housing developer, may not understand this part of the process and become frustrated. Again, this issue is out of the hands of the owner and places them at the mercy of the City processes.

Table 3.1 - Median for ADUs produced arranged by design professions producing the most ADUs⁶⁸

Rank	Plan Maker	Median Calendar Days to Permit	#ADU Permits	Total Construction Value ⁵ (\$)
1	Yee, Xiang	101	10	1,497,000
2	ACZON, Eliezer Y.	92	5	647,000
3	Nago, Brad T.	126	5	743,000
4	Yamamoto, Ronald A.	73	5	1,537,000
5	QUINN, GREGORY A.	102	4	273,000
6	Noda, Roy A.	167	3	285,000
7	STRUCTURAL HAWAII INC	144	3	224,500
...	(others – not shown)	125	65	5,314,950
				10,521,450

Mr. Questor Lau, who previously identified the Rec Room Loophole and is a planner at HHF Planners, has been following the ADU law closely. Mr. Lau claims:

One reason ADU and SFD[Single-Family Dwellings]/TFD[Two-Family Dwellings] permits take about the same time may be that ADU permits often include other work – additions or alterations that trigger similar regulatory review requirements as new SFD/TFD permits (i.e. Both ADU's and SFD/TFD plans typically must be approved by the Building Code examiner, Board of Water Supply, and Wastewater).⁶⁹

In his analysis, he has identified that the median ADU permit time is approximately 120 days not including the pre-check submission which takes an additional 30 days. Of the

⁶⁷ Questor Lau, "Accessory Dwelling Unit (Adu) Status Update," (Scribd2016).

⁶⁸ Ibid.

⁶⁹ Ibid.

ADUs pursued as of February 2017, even experienced professionals assisting their client through the permitting purgatory are experiencing longer than average wait times.⁷⁰ These above average delays can be very disheartening to a first-time developer.

The City, in response to the long wait times, has modified the process by adding the pre-check form, which, as mentioned above, takes about 30 days to be approved. This additional step allows the various departments: Wastewater Disposal, Board of Water Supply, and DPP Traffic Division, to assess whether the property meets the minimal infrastructural requirements discussed earlier in the chapter. Though the pre-check is a step in the right direction, this measure is not a complete solution if the ADU developers are still facing longer than average wait times.⁷¹

**ACCESSORY DWELLING UNITS (ADU)
RECOMMENDED PUBLIC FACILITIES PRE-CHECK FORM**
DEPARTMENT OF PLANNING AND PERMITTING (DPP)

TAX MAP KEY

Zone	Sec	Plat	Par	Lot
------	-----	------	-----	-----

ZONING DISTRICT: _____
LOT AREA: _____

ADDRESS/LOCATION OF PROPERTY: _____

APPLICANT: _____ PHONE: _____
AGENT: _____ PHONE: _____

ADU - PART I (To be completed by applicant)

- PROPOSAL FOR: (check only one)
 - One new attached unit
 - One new detached unit
 - Alteration work only (conversion of garage, guest quarters, recreation rooms, basement, etc.)
 - Other _____
 - Use of existing attached second unit
 - Use of existing detached second unit
- TOTAL NUMBER OF BEDROOMS IN BOTH UNITS: _____ (for Dept. of Health review, if required)
- PARCEL NOW SERVED BY OR HAS: (check Yes or No)
 - a. Meets minimum lot size required Yes No
 - b. City water Yes No
 - c. City sewers Yes No
 - d. Cesspool or septic tank. If "Yes", see II b. - State Department of Health Yes No
 - e. Direct access to a street with minimum paved roadway width of 20 feet (18 feet if street serves no more than 6 lots) Yes No
 - f. Sufficient area for required number of parking spaces Yes No

ADU - PART II (To be completed by government agencies)
If you do not meet any requirement permit cannot be granted.

I. DPP CUSTOMER SERVICES DIVISION: Parcel meets zoning and lot size/dimension standards.
 Yes No Checked by: _____ Signature _____ Date _____

II. WASTEWATER DISPOSAL (either a or b)
a. DPP WASTEWATER BRANCH: Sewer service is available and capacity is adequate.
 Yes No Checked by: _____ Signature _____ Date _____
b. STATE DEPARTMENT OF HEALTH - WASTEWATER BRANCH: Existing/proposed individual wastewater system meets requirements.
 Yes No Checked by: _____ Signature _____ Date _____

III. BOARD OF WATER SUPPLY - SERVICE ENGINEERING: Existing water system is adequate.
 Yes No Checked by: _____ Signature _____ Date (Valid for 120 days) _____
BWS ONLY: Approval for one-time 90-day extension.
Checked by: _____ Signature _____ Date (Valid for 90 days) _____

IV. DPP TRAFFIC REVIEW BRANCH: Meets minimum roadway requirements.
 Yes No N/A Checked by: _____ Signature _____ Date _____

Additional comments (attach if necessary): _____

Revised March 2016

Figure 3.6- ADU Public Utilities Pre-Check Form⁷²

⁷⁰ Ibid.

⁷¹ "Accessory Dwelling Units (Adu) Recommended Public Facilities Pre-Check Form."

⁷² Ibid.

To get a better understanding of the permitting process, one must investigate how to acquire a building permit. According to the DPP, one must obtain a permit for each of the following:

- *To erect, construct, alter or remove, or demolish any building or structure (including fences, retaining walls, and swimming pools).*
- *For any electrical work over \$500 (Sec. 18-1), or plumbing over \$1000 (Sec. 18-31.1 (b)) All work shall be performed by licensed electrical/ plumbing contractors.*
- *To construct or alter any sidewalk, curb, or driveway in public rights-of-way.*
- *A sign permit is required to install, construct, alter, relocate, or reconstruct any sign. A temporary permit is required to erect any tent or similar structure to be used for religious or commercial purposes, such as rallies, festivals, or carnivals.⁷³*

Additionally, for a residential building permit, there are certain requirements. Figure 3.7 below is a checklist that illustrates a guide to the requirements needed in residential construction. Various entities must review documents and provide their approval. These numerous reviews can be problematic and time-consuming. Revisions, edits, and the time taken to evaluate one aspect can hold up following checks and draw out the overall permitting process. If one review is unapproved and sent back with comments, the process may take longer than expected. Ensuring that the permitting process goes smoothly is important to preventing frustration.

⁷³ "Do You Need a Building Permit?," ed. Department of Planning and Permitting (2011).



City & County of Honolulu, Department of Planning and Permitting
Checklist for Residential Building Permit Application

The purpose of this checklist is to provide a **GUIDE** to assist permit applicants as to the minimum information required for plans review for City and County of Honolulu single-family/two-family detached residential building permit applications. If the minimum information indicated below is not provided, the plan review may not be completed in a timely manner and/or denied plan submittal.

Plans shall be of sufficient clarity to indicate the extent of proposed work and show in detail that it will conform to the provisions of all relevant laws and ordinances. The applicant should reference **checklist items to the page number of the application packet.**

SUBMITTAL REQUIREMENTS: (MUST BE DRAWN TO SCALE AND DIMENSIONED)		NOTE/PAGE:
1.1	<input type="checkbox"/> Required A completed online Building Permit Application	
1.2	<input type="checkbox"/> Required No. of sets of plot/site plans: 4 (minimum paper size of 8 1/2 X 11) Showing the following where applicable: <ul style="list-style-type: none"> North arrow, location of building on lot, existing and proposed structures and easements on lot, setbacks to property lines, spot elevations and/or contour lines, driveway, utility locations, building coverage area and percentage of coverage, lengths of property lines, and parking layout. 	
1.3	<input type="checkbox"/> Required Floor plan (new and existing Floor plans) Showing the following where applicable: <ul style="list-style-type: none"> Room identification, door and window size, location of smoke detector, water heater, ventilation fans, plumbing fixtures, lanai, decks, etc. 	
1.4	<input type="checkbox"/> Required Foundation plan (new and existing Foundation plans) Showing the following where applicable: <ul style="list-style-type: none"> Anchor bolts, hold-downs and reinforcing pads, connection details, vent size and location 	
1.5	<input type="checkbox"/> Required Floor/Roof framing plan (new and existing Floor/Roof framing plans) Showing the following where applicable: <ul style="list-style-type: none"> Member sizing, spacing and bearing locations Attic ventilation Roofing insulation Connection details 	
1.6	<input type="checkbox"/> Required Cross sections with details Showing the following where applicable: <ul style="list-style-type: none"> Framing-member size and spacing Headers, joists, sub-floor, wall and roof constructions Ceiling height, siding material, handrail, stairs and step section, details, etc. 	
1.7	<input type="checkbox"/> Required Elevation views (indicate existing and finish grades) Showing the following where applicable: <ul style="list-style-type: none"> Bath elevations, Kitchen elevations Full height exterior elevations New window and door schedule or details 	
1.8	<input type="checkbox"/> Required Building envelope per the Land Use Ordinances (LUO)	
1.9	<input type="checkbox"/> Required Light and ventilation per Housing Code for rooms adjacent to new work	
1.10	<input type="checkbox"/> Required Hawaii registered architect or structural engineer's stamp and signature <ul style="list-style-type: none"> Market value of work on one-storied buildings exceed \$40,000 Market value of work on two-storied buildings exceed \$35,000, or The principal structural members are of reinforced concrete or structural steel Requested by the Plan Examiner 	
ISSUANCE SUBMITTAL REQUIREMENTS:		NOTE/PAGE:
2.1	<input type="checkbox"/> Required Contractor Statement	
2.2	<input type="checkbox"/> P <input type="checkbox"/> NA Specialty Contractor Statement	
2.3	<input type="checkbox"/> P <input type="checkbox"/> NA Special Inspection Form	
2.4	<input type="checkbox"/> P <input type="checkbox"/> NA Affidavit/Restrictive Covenant	

PRINTS/SIGNATURE _____

DATE _____

Figure 3.7 - DPP residential checklist for permit applications⁷⁴

In the article Permit Purgatory, Dennis Hollier expands on the frustration faced when pursuing a building permit for a small restaurant space. Though this example deals with commercial property, where reviews may require a different level of scrutiny, it still illuminates issues in the permitting process. Hollier elaborates on the frustrations of Hideo Simon, a local restaurant owner, trying to construct his new restaurant Square Barrels in 2015.

The problem, he says, is it's just too complicated and time-consuming to get even a basic building permit. An application, particularly for a commercial project, may require a handful of departments to sign off. In addition to the review at the Department of Planning and Permitting, it may need to be stamped by the fire department, the Board of Water

⁷⁴ City and County of Honolulu, "Checklist for Residential Building Permit Application," ed. Department of Planning and Permitting (2008).

Supply, wastewater and elevator officials, the State Historic Preservation Division, et al. Navigating this process, Simon says, can be complex.

The article continues to discuss how Hideo is not a stranger to the permitting process having gone through it before with his other successful restaurant Pint + Jigger.⁷⁵ Thus the experience may be problematic and frustrating to a first-time homeowner who is unaware of what to expect.

When dealing with permitting, the wait times can be longer than expected. A homeowner that is pursuing an ADU invests a substantial amount of time, effort, and money into his or her development project and may not be unaware of the additional time required idly waiting for permit approvals. In the short term, it is necessary to inform the homeowner thoroughly about the ADU permitting process. A complete understanding of the permitting process may reduce the homeowner's stress and frustration during the process. Licensed professionals are valuable to the process and can ensure that it goes as smoothly as possible. In the long run, however, a more optimized permitting process that makes use of digital technologies and tight integration with the allied professions should be implemented.

LOW-COST DESIGN

Building an ADU will very likely require an architect. It is important for the homeowner to know ahead of time that they will need approval by an architect or structural engineer for construction estimating over \$40,000⁷⁶. \$40,000 is not a lot in the pursuit of a dwelling unit. In pursuing an ADU without the guidance of a licensed designer, one risks not having the design meet safety, durability, environmental, and health precautions the architect can provide not to mention their expertise to get through the permitting process. The licensed professional is providing the homeowner more than construction documents but rather is providing a service of expertise that is necessary for the success of the project. A homeowner should find an architect who is competent, designs

⁷⁵ Dennis Hollier, "Broken: Stuck in Permit Purgatory," (2015), <http://www.hawaiiibusiness.com/broken-stuck-in-permit-purgatory/>.

⁷⁶ "Do You Need a Building Permit?."

in a way the homeowner likes and that the homeowner feels he or she will work well. The relationship between architect and client is critical to the success of the project. Varying levels of engagement and design knowledge potentially divide the intentions of both the homeowner and the designer. By examining the position of both parties, it is possible to assess a way to bring the two closer together. The collaboration of the homeowner and the architect must work well to ensure a successful ADU.

An ADU build has ramifications to both the homeowner and the architect. For the homeowner, it is a significant investment of time and money. And if the build is unsuccessful, the ADU could become a sore spot on his property for years to come. On the other hand, the Architect invests time and effort on the design of the ADU and educating the homeowner about the ADU build process. The architect must also draw out from the owner what he or she wants out of the ADU design. And while designing a 400 square foot accessory dwelling unit may be of lesser importance to a design firm or architect with potentially larger more profitable projects in the works, if the build is unsuccessful, he or she risks his or her design reputation that could affect their future earnings. With varying intentions and levels of commitment, there is potential for dissatisfaction on both sides.

The role of the architect in the ADU development is his or her essential expertise in the planning, design, documentation and coordination of the ADU. The skill of the architect is a byproduct of many years of schooling, examination, and practice. Furthermore, the architect will have a network of allied professionals who will assure that a job gets completed efficiently. The service of an architect is not cheap. Based on reported costs, the service of a principal architect is around \$135 to \$175 per hour while the service of an entry level designer is around \$65 per hour.⁷⁷ Therefore it would only make sense to make the most efficient use of consultation time to reduce the cost to the owner, particularly for a low-budget project. Thus, time should be spent refining and pursuing desired outcomes rather than exploring numerous options and revisions based on uninformed design choices.

⁷⁷ "How Much Does It Cost to Hire an Architect?," <http://www.homeadvisor.com/cost/architects-and-engineers/hire-an-architect/>.

Architect Gerard Heumann discusses the challenge in dealing with naive clients in the overall development process. He states that the “most difficult of all the obstacles for the architect to overcome is the tastes and foibles of clients.” Further, he states that “Most clients are totally unprepared for their role. A substantial part of the environment is shaped by people who have little or no visual training and who are simply unaware of the aesthetic, environmental and social consequences of their decisions.”⁷⁸ Heumann’s solution lies in the informed client who in consultation with professionals can make design-conscious decisions with assistance.

In another article, architect Lee Calisti elaborates on the strategic nature of taking on new projects. His article discusses when an architect should turn down a commission regardless of size. In his opinion, he outlines a few basic questions that establish a determination:

- *Is there good chemistry with the client (contract negotiation, initial meetings, and early relationship building) based on meetings and discussions thus far?*
- *Is the project interesting? (challenging, exciting, engaging, fits personal goals, can focus on it)*
- *Will this project type-cast you into doing more of this type when you might not wish to do more? (style, building type, project size)*
- *Do you have the time to do it well? (schedule, office load)*
- *Is it a high risk? (budget, building type, schedule, fee, changes, liability)*
- *Do you have the experience? (building type, project size, technical concerns, current knowledge base, ability to learn)*
- *Is it good business (profitable, lead to additional work, extend reputation, name, etc. into wider market)*

If the response to any of these questions is “no” then an architect should assess whether the project is worthwhile.⁷⁹ Thus it becomes necessary to evaluate an ADU project. The architect must examine his or her intentions while simultaneously assessing the needs of the client.

⁷⁸ Gerard Heumann, "Well-Informed Clients Come before Fine Architecture," (2014), <http://www.jpost.com/Opinion/Well-informed-clients-come-before-fine-architecture-384273>.

⁷⁹ Lee Calisti to Think | Architect, 2015.

A low budget ADU as opposed to a custom medium to high-end ADU may affect the determination of whether the project may be worthwhile to an architect. Unfortunately, housing and income are issues in Hawai'i. If ADUs are to provide affordable rental stock, then these new ADUs will likely need to be produced on the low-cost end by ordinary individuals to make a substantial impact on the affordable housing problem. There needs to be a way to make the development of low to medium cost ADUs as a worthwhile venture for both the designer and the client. In the short term, a solution to the low-cost design issue is through education, using a support system that helps inform clients and clarify the goals and ideals of the project before engaging expertise services. In the long term, the expansion of the Decision Support System can optimize the design processes and link ADU developer to a qualified and available architect.

CHAPTER 4 : ADU FUTURE ISSUES

While addressing present day issues, a design can also deal with concerns about future conditions. As an exploration of future possibilities, this research will investigate a few considerations with the potential to improve the effectiveness of the support system and the ability to generate housing in the next generation. This expansion will look at concerns dealing with waste systems, transportation, construction, and the digital frontier. These considerations are speculative and will require more investigation, but imagination and speculation pave the way for innovation.

INDEPENDENT WASTEWATER

As discussed earlier, present inadequacies in the wastewater infrastructure of Honolulu County exist. These inadequacies are a major hindrance to the development of ADUs. One solution is an upgrade of the infrastructure to add for the capacity for new developments. Such an upgrade, however, can be timely and costly. In the long run, an upgrade may not be a significant strategic solution for better managing waste from new developments. Further new development will likely require additional upgrades which can potentially cause a similar inadequacy of the sewer system. Another solution may be to look into innovation and development of independent waste treatment systems. This decentralization of wastewater management does not rely on a costly public infrastructure and will advance the development of closed-loop ecological systems.

Conceptually, a locality can be self-sufficient in its environmental waste cycle. The current modern system, however, distances the externalities and does not preserve a full environmental loop. As the modern city expands our waste management system can ideally develop in a way that accommodates growth in a sustainable fashion. Instead, the current practice takes waste from one area and dumps it somewhere else, supposedly, out of the way. Dumping grounds include the ocean or landfills. The innovation of independent systems may facilitate an alternative waste management system that, while preserving the integrity of the environment, has the potential to remove a major blockade in ADU development.

A dwelling unit must connect to a wastewater system by law. Additionally, if the dwelling is within the proximity of a public system, it must connect to that public system.⁸⁰ The rigidity of this regulation makes it difficult to employ independent systems. The justification for these regulatory obstacles is legitimate in that independent systems, traditionally cesspools, pose a potential risk to the safety and health of the public. If such a system is defective, it releases untreated effluent into the environment.⁸¹ Defective individual systems affect the community by contaminating the ground and subsurface fresh water. Numerous independent cesspool systems pushed legislators to instate a moratorium to all new cesspool systems in 2015. The cesspool ban also incorporated a \$10,000 tax credit for the upgrading of cesspools to septic or sewer systems over the next five years.⁸²

Currently, there are about 90,000 cesspools in the State of Hawai'i. About 11,000 on Oahu alone. Together the cesspools in Hawaii purge about 55 million gallons sewage into the surrounding lands and groundwater every day. The widespread use of cesspools potentially impacts water quality, the safety of Hawaii's coral reefs, and potentially promotes the unwanted growth of algae and bacteria.⁸³ Unregulated, a boom in the construction of new ADUs would exacerbate these issues if they all implemented cesspools. For these reasons, a ban on cesspools is reasonable. The State, however, may be premature discourage the use of the independent system. The problem with cesspools is the lack of waste treatment and not the independence of the system. Independent waste systems that can treat the effluent to acceptable levels may be able to preventing the contamination of the environment while allowing development to proceed uninhibited by inadequate wastewater infrastructure.

⁸⁰ "Wastewater Systems."

⁸¹ "State Bans New Cesspools, Offers Tax Credit to Upgrade to Sewer or Septic System," (2016), <http://khon2.com/2016/03/12/state-bans-new-cesspools-offers-tax-credit-to-upgrade-to-sewer-or-septic-system/>.

⁸² Ibid.

⁸³ "Cesspools in Hawaii," State of Hawaii, Department of Health, <http://health.hawaii.gov/wastewater/cesspools/>.

Outlined by Clean Water Action, an environmental grassroots organization that has been around since 1972 fighting for communities in response to environmental concerns,⁸⁴ decentralized wastewater systems can provide the following benefits:

- Reduction of existing infrastructure maintenance
- Reduction of new infrastructure cost
- Resilience to failure of centralized systems
- Restoration of ecology through the replenishment of natural aquifers
- Recycling of nutrients back into the landscape
- Improved open space and air quality
- Homeowners bear the system costs⁸⁵

Independent wastewater systems provide many benefits as long as not abused or neglected. When public systems fail, development is halted until adequate adjustments or upsizing is complete. When private systems fail, the homeowners will need to fix the issue because effective legislation can encourage compliance. In Monroe, Florida, the county has approximately 30,000 individual wastewater systems. These private sewer systems do well because of new treatment standards, advanced nutrient reduction systems, renewable operating permits, maintenance contracts, and annual inspections. As a result, Monroe's treatment systems demonstrate a 75% reduction of waste discharge than conventional independent systems.⁸⁶

Factors that limits the use of the independent system in Hawai'i are lot sizes, ground composition, and water table levels. Independent systems take household wastewater and dispose of it in the land within the property boundaries. An area on the property dedicated to the disposal and treatment of wastewater, This area, known as a leach field, has specific sizing requirements regarding the percolation rate of the soil on the site. In Hawaii, however, there are many areas where the ground is not very suitable for sewage disposal due to the high water table and high percolation rate of the ground. These conditions result in the direct dumping of untreated sewage into the groundwater,

⁸⁴ "Who We Are," Clean Water Action, <http://www.cleanwateraction.org/about/who-we-are>.

⁸⁵ Clean Water Action and Clean Water Fund, "Why Decentralize Wastewater Treatment?."

⁸⁶ "Case Studies of Individual and Clustered (Decentralized) Wastewater Management Programs," ed. United States Environmental Protection Agency (Office of Wastewater Management, 2012).

which poses health hazards.⁸⁷ Future innovations in treating effluent before releasing it into the environment which may increase the dependability of independent systems for the State of Hawai'i.

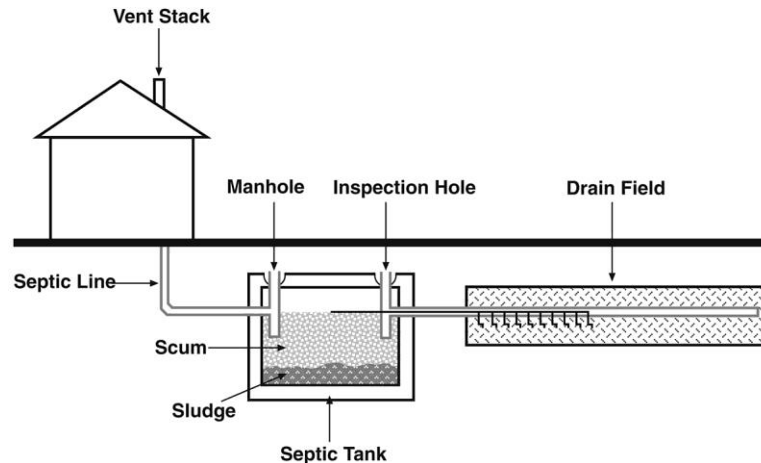

Figure 4.1– Diagram of basic septic system depicting the relationship of the dwelling to the septic tank and leach field (drain field)⁸⁸

The state already has precise definitions for the implementation of independent wastewater systems. According to these regulations, a property must be at least 10,000 square feet in size and not be in proximity of a public sewer system. The National Sanitation Foundation (NSF) must approve the independent system.⁸⁹ The NSF does testing to regulate the health impacts of various products ranging from water treatment filters to composting toilets. The use of a standard for monitoring the performance of independent wastewater systems and strict performance standards can allow for the innovation of independent systems which may one day make the minimum 10,000 square feet lot requirement obsolete. The ADU law requires that a lot only needs to be 3500 square feet which is far lower than 10,000 square foot requirement. The removal of the size requirement may allow ADUs to take advantage of independent waste systems where the environment and technology permit. Newly implemented independent waste systems that incorporate maintenance, operation and inspection requirements could allow for the removal of the regulation that new dwellings connect to the public sewer system allowing for an increase in ADU development.

⁸⁷ "Cesspools in Hawaii."

⁸⁸ "All About Septic Systems," FamilyEducation.com.

⁸⁹ "Wastewater Systems."

ALTERNATIVE TRANSPORTATION

The development of ADUs as a means to addressing the affordable housing issue will have an effect on traffic. As new dwellings become approved and constructed, the new residents will increase the urban density. If each new residents has a vehicle, the current roadway infrastructure is not designed to accommodate the rapid increase in population. Thus, the development of ADUs must address the issue of new parking allocation on properties to accommodate new ADU residents. The current ADU ordinance requires one additional off street parking stall per new ADU.⁹⁰ As a straightforward response, the new parking allotment solves an issue of accommodating new vehicles in the urban setting. It also relaxes the parking scarcity within a half mile of a rail transit station. It fails, however, to address the deeper question of how to alleviate the added stress to the already strained transportation infrastructure caused by the additional vehicles.

The City and County of Honolulu is dependent upon a central, H1/H2 corridor. The H1/H2 corridor is the primary transport conduit connecting the suburban western side of the island to the urban eastern side of the island. The transportation infrastructure is inadequate in capacity causing serious traffic congestion issues. It also lacks the ability to expand due to the dense development surrounding the corridor over the entire length. According to the INRIX 2015, a nation poll that ranks states with the worst traffic in the country in regards to average time wasted, Hawaii ranks tenth on the list. Hawai'i commuters waste on average about 49 hours annually⁹¹. Furthermore, in the past ten years, the number of fatalities caused as a result of traffic incidents has fluctuated between 90 to 160 annually.⁹² With a growing population, Hawai'i can not depend on the personal vehicle as the sole solution for the future transportation but must embrace alternative transportation options.

One alternative transportation option that may alleviate traffic is the Hawai'i light rail system currently being constructed. This large infrastructure project is currently on hold

⁹⁰ *Relating to Accessory Dwelling Units.*

⁹¹ "Inrix 2015 Traffic Scorecard Sets Benchmark for U.S. Cities as Federal Government Accelerates Smart City Spending," INRIX, <http://inrix.com/press-releases/scorecard-us/>.

⁹² "General Statistics," Insurance Institute for Highway Safety Highway Loss Data Institute, <http://www.iihs.org/iihs/topics/t/general-statistics/fatalityfacts/state-by-state-overview>.

suffering a shortfall of 2.3 billion dollars as of 2016.⁹³ The State must decide between raising more funds or postponing segments of the project. The postponement of the next segments of the rail project will abandon a significant portion of its expected rider demographic by not reaching the downtown business district. With the completion of the rail in question, other forms of alternative transportation must be explored to address Hawaii's transportation problems.

Another alternative transportation option is bike-friendly city planning as demonstrated by Copenhagen and Amsterdam. According to the Copenhagenize blog that emerged to evaluate and promote the bike infrastructure, Copenhagen and Amsterdam rank as the top bike-friendly cities in the world.⁹⁴

Every city used to be bicycle friendly before planners and engineers started to change the paradigm and plan for cars and relegate bicycle users, pedestrians and public transport users to third class citizens. Now those cities around the world who are taking up the challenge and modernizing themselves by implementing bicycle infrastructure, policy, bike share systems, etc. - as well as restricting car use - are the cities we all look to for New Century inspiration.⁹⁵

⁹³ John Hill, "Feds Extend Deadline for Honolulu Rail Recovery Plan," (2016), <http://www.civilbeat.org/2016/12/feds-extend-deadline-for-honolulu-rail-recovery-plan/>.

⁹⁴ "The Criteria for the Copenhagenize Index," Copenhagenize Index.

⁹⁵ Ibid.

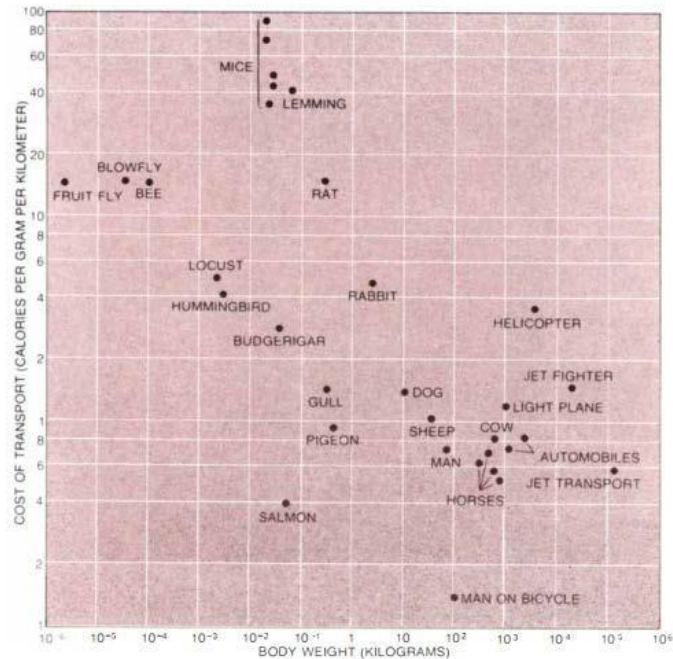

MAN ON A BICYCLE ranks first in efficiency among traveling animals and machines in terms of energy consumed in moving a certain distance as a function of body weight. The rate of energy consumption for a bicyclist (about .15 calorie per gram per kilometer) is approximately a fifth of that for an unaided walking man (about .75 calorie per gram per kilometer). With the exception of the black point representing the bicyclist (*lower right*), this graph is based on data originally compiled by Vance A. Tucker of Duke University.

Figure 4.2– Diagram depicting the efficiency of transportation modes in relation to energy input⁹⁶

Cities are learning that city planning prioritizing the needs of pedestrians as opposed to a dependence automobiles can be effective. Such planning would entail a reduction of automobile networks and a development of alternative transportation systems that allow the pedestrian to interact and depend on his or her walkable and bikeable surroundings. “Studies from Denmark tell us that for every kilometer cycled, society enjoys a net profit of 23 cents. For every kilometer driven by car, we suffer a net loss of 16 cents.”⁹⁷

Copenhagen and Amsterdam are examples of cities planned around Transit-Oriented Development (TOD), which prioritizes a walkable neighborhood within a half-mile of reliable public transportation. TOD projects are trending as developers find new development laws beneficial. In Chicago, the municipality passed a transit-oriented development ordinance in 2013. This new law allows developers to build projects with

⁹⁶ Carlton Reid, "How the Bicycle Beats Evolution and Why Steve Jobs Was So Taken with This Fact," (2015), <http://www.bikeboom.info/efficiency/>.

⁹⁷ Pratap Padode, "Why Cycling Should Be Mandatory in Smart Cities," <http://india.smartcitiescouncil.com/article/why-cycling-should-be-mandatory-smart-cities>.

greater density, taller buildings, and reduced parking, provided they meet certain transit orient design criteria. In these developments, bikes are an essential component to the success of the project. Since the passing of the ordinance, there have been 30 such projects that have been completed or are in the works for completion.⁹⁸

Hawaii is also beginning to transition towards TOD. In 2009 the city passed Ordinance 09-04 which set the framework for the implementation of TOD.

It has been consistently noted about successful TOD programs of other cities that community-based input is an important element of TOD programs, and that one specific set of regulations cannot adequately address TOD needs and opportunities across all transit stations. Therefore, to assure that Honolulu will have a successful TOD program, a general land use scheme must be created that provides for a deliberate, inclusive process to plan for TOD so that well-defined, meaningful, and appropriate regulatory and incentive programs can be adopted for each area around a transit station or type of station.⁹⁹

While taking advantage of more efficient use of land, TOD can provide more walkable, healthier, economically vibrant communities, safe bicycling environments, convenient access to daily household needs as well as special events, and enhancement of neighborhood character, while increasing transit ridership.¹⁰⁰

As Honolulu becomes a more transit-oriented city, bicycles play a bigger role in the urban setting. In 2012 the city launched a new bike program which is effectively pushing towards the creation of new bike thoroughfares connecting key points and services.

⁹⁸ Pamela McKuen, "Transit-Oriented Housing in Chicago Is Back on Track," (2016), <http://www.chicagotribune.com/classified/realestate/ct-transit-oriented-developments-re-0925-20160922-story.html>.

⁹⁹ *Relating to Transit Oriented Development*, 10.

¹⁰⁰ *Ibid.*

Currently, the County has 2 miles of protected bike lane with plans to create more bike-friendly routes.¹⁰¹ Figure 4.3 depicts potential benefits of transit oriented development.

BENEFITS OF TRANSIT ORIENTED DEVELOPMENT

Americans believe transit oriented development provides an array of benefits ranging from lifestyle to environmental to economic.

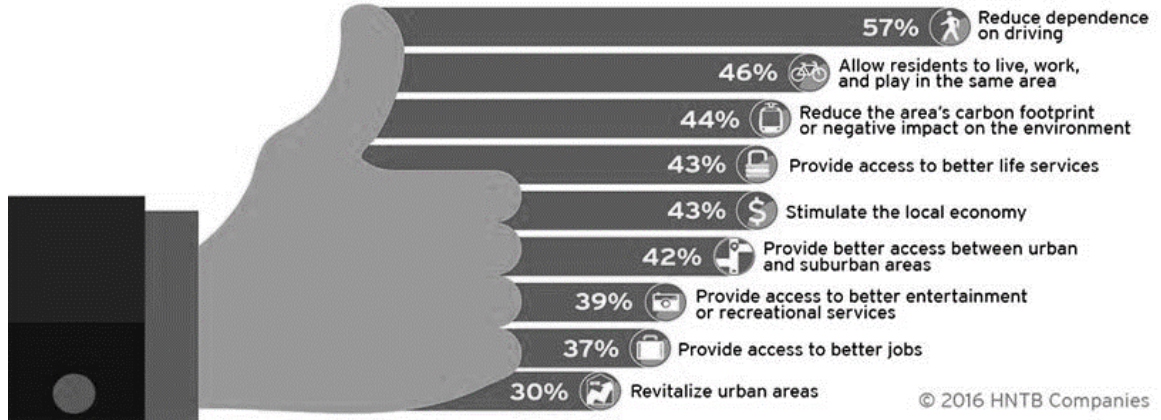

Figure 4.3– Diagram depicting positive aspects of Transit Oriented Development¹⁰²

¹⁰¹ City and County of Honolulu, "Bicycle Program," City and Council of Honolulu, <https://www.honolulu.gov/bicycle>.

¹⁰² HNTB Companies, "Benefits of Transit Oriented Development," (2016).

Commuters may still need to travel far distances. In over 20 metropolitan major urban areas, some residents employ a car share program. This shared transportation system allows individuals to rent a car at low cost to indulge in non-work related journeys. The benefit of the car share program is that people do not need to own the vehicle and can still access one when it is needed. "The shared cars eliminate upfront ownership costs, but members still maintain auto access while leading a less car-dependent lifestyle."¹⁰³

With innovative approaches to alternative transportation, it is possible that the necessity for car ownership may decline. As a long-term consideration, the parking requirement in the ADU ordinance may need reconsideration. Currently, however, the parking requirement creates another issue in gaining permission for ADU development. Properties that are small or topologically restricted must find a way to include an off-street parking space for approval for ADU construction. In a future where alternative transportation is readily accessible, it may not be necessary to include the parking requirement where bike thoroughfares and car share programs are in proximity. The ADU regulation could be amended to say:

One off-street parking space per accessory dwelling unit shall be provided in addition to the required off-street parking for the primary residential unit, except for accessory dwelling units located within a one-half mile of a rail transit station [, bike transportation network, or carshare hub]. For the purposes of this section, the minimum distance requirement shall be measured as the shortest straight line distance between the edge of the station area and the zoning lot line(s) of the project site.¹⁰⁴

The amendment to the regulation would allow for the expansion of ADUs in conjunction with smarter urban planning that concentrates growth in high-density walkable cities, and TOD. Areas that implement these strategies could increase density quickly while providing affordable housing through the removal of the required additional parking stall.

¹⁰³ Elliot Martin and Susan Shaheen, "The Impact of Carsharing and Household Vehicle Ownership," (2011).

¹⁰⁴ *Relating to Accessory Dwelling Units.*

RENEWABLE ENERGY

In 2015, Governor Ige signed four bills that put into motion a plan to achieve a 100% renewable energy state by the year 2045. The bold action plan shows a commitment to break away from the dependency on fossil fuels. This plan makes the State of Hawai'i the first in the nation to adopt a 100% renewable energy standard.¹⁰⁵ The mandate spurred by a 2008 study which determined due to the unique circumstances found in the Islands of Hawai'i; there is the potential to fulfill 60 to 70 percent of energy demands with renewable and passive energy strategies.¹⁰⁶ The fight for renewable energy is an ongoing battle but has great potential to revolutionize Hawaii's carbon footprint.

In 2014, the State set a goal to reduce its fossil fuel use by 4300 gigawatt-hours by 2030. Additionally, the State found a reduction of petroleum use in transportation could lead to a two-third reduction of current energy consumption.¹⁰⁷ With over 30 percent of single-family homes implementing rooftop solar, as of March 2016, Hawaii has already met and exceeded its renewable energy intermediate benchmarks. In 2015, 23 percent of electricity generation came from renewable sources. However, experts claim getting the passive power production beyond the 50 percent benchmark and above will be difficult. The problem is reconciling the time the sun produces passive energy, during the day, and the peak energy usage time, in the evening when the sun is no longer available.¹⁰⁸ To achieve the goal of 100% renewable energy by 2045, the State needs homeowners to make a contribution to the renewable energy mandate.

The energy use of an ADU is similar to a single-family home. However, an owner can orient the unbuilt ADU in a manner that is efficient and reduces energy use through active cooling. The cooling will require mitigation of internal glare by utilizing extended roof overhangs and screening elements to the east and west directions where the

¹⁰⁵ Duane Shimogawa, "Governor Signs Bill Setting Hawaii's Renewable Energy Goal at 100%," (2015), <http://www.bizjournals.com/pacific/news/2015/06/08/governor-signs-bill-setting-hawaiis-renewable-renewable.html>.

¹⁰⁶ Hawaii Clean Energy Initiative, "Transforming Power in Paradise : The Hawaii Clean Energy Initiative " (2017).

¹⁰⁷ Ibid.

¹⁰⁸ Gavin Bade, "Getting to 100% Renewables: How Hawaii Plans to Get Fossil Fuels Off the Grid," (2016), <http://www.utilitydive.com/news/getting-to-100-renewables-how-hawaii-plans-to-get-fossil-fuels-off-the-gr/416176/>.

evening and morning sun will pierce into the building. Another energy idea to incorporate into a new ADU is independent power generation and storage so the ADU can strive for a net-zero building or one that generates more energy than it uses.

DECENTRALIZED CONSTRUCTION

Another consideration regarding future development of ADUs is decentralized construction. A news article published in 2016 claims that the current construction market is close to a tipping point as labor and management fees have been on the rise.¹⁰⁹ Additionally, a significant number of large-scale projects are in the works or the process of being built. A problem occurs when homeowners seek to build ADUs during a busy construction boom with limited available labor. As contractors evaluate the construction market, they may also weigh jobs based on their relative staff and potential profits. Limited by the laborers on their construction team, contractors may prefer to put their limited resources into bigger projects that earn more profits. Thus, homeowners might end up paying a premium price for labor when constructing an ADU in a busy market.

In the construction process, innovations are offered alternatives to on-site fabrication. In "Refabricating Architecture" the authors question the efficiency of current development practice. When compared to the production capabilities of automotive or airline manufacturing, it is a wonder if similar production capabilities can be applied to the construction industry. The book *Prefab Architect*, written by Ryan Smith, investigates the issues surrounding off-site production and the benefits of prefabrication and the benefits of decentralized construction. Some of the benefits of decentralized construction include:

¹⁰⁹ Duane Shimogawa, "Contractors Deal with Hawaii's Rising Construction Costs: Slideshow," (2016), <http://www.bizjournals.com/pacific/blog/2016/01/contractors-deal-with-hawaiis-rising-construction.html>.

- Time savings through simultaneous productions
- Quality and precision due to off-site manufacturing conditions
- Reduced on-site disturbance (i.e. noise, dust, equipment)
- Independent costs from local labor market
- Economies of scale in repetition¹¹⁰

Modularity in design allows for a decentralization of the construction process. The book *Design in Modular Construction*, by Mark Lawson, discusses varying levels of modularity which include materials, components, elements, volumetric modular systems, and complete systems.¹¹¹ The first three levels of modularity: materials, components, and elements are staples for modern buildings. Materials include standard bricks, lumber, etc. Components include precast floors, roof trusses, bathtubs, etc. Elements include structurally insulated panels (SIPS), and unitized curtain walls. The next two levels: volumetric modular systems and complete systems are areas currently being explored in architecture. Volumetric modular systems would entail the construction of a prefabricated volume with features and amenities built into the volume itself. An example of the volumetric unit can include the Dymaxion Bathroom designed by Buckminster Fuller.¹¹² Lastly, complete systems entail a module built to completion and simply installed on site. An example of a complete system can include the modular units used by the Star Apartments by Michael Maltzan.¹¹³ Thus, “[p]refabrication is an economic sector growing faster than on-site construction sectors, making it advantageous for project teams to consider off-site production as a longer-term investment. (Curtain wall, structural steel, and precast)”¹¹⁴

¹¹⁰ Ryan E. Smith, *Prefab Architecture : A Guide for Architects and Construction Professionals* (Hoboken, N.J.: Wiley, 2010).

¹¹¹ Mark Lawson, Raymond Ogden, and Chris I. Goodier, *Design in Modular Construction* (London: Taylor & Francis, 2014).

¹¹² Buckminster Fuller Institute, "Dymaxion Bathroom," <https://www.bfi.org/about-fuller/big-ideas/dymaxion-world/dymaxion-bathroom>.

¹¹³ "Star Apartments," <http://www.mmaltzan.com/projects/star-apartments/>.

¹¹⁴ Lawson, Ogden, and Goodier, *Design in Modular Construction*.

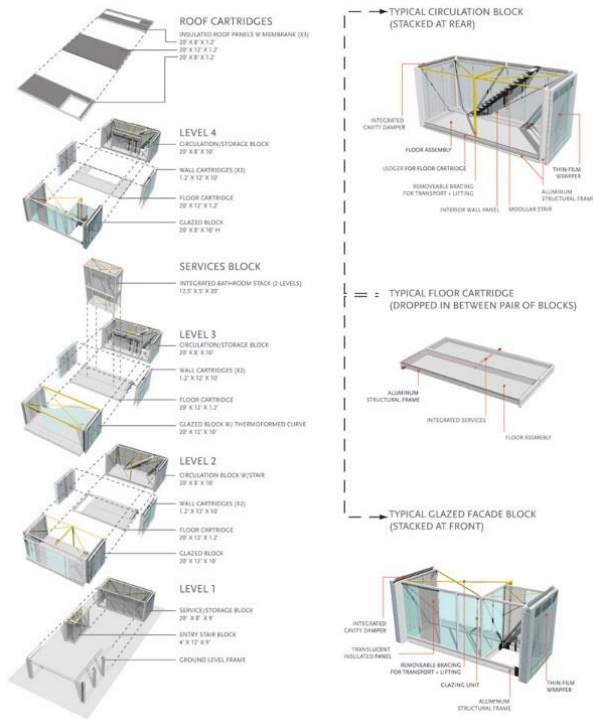

Figure 4.4– Assembly diagram of the Cellophane House which demonstrates a modular method to construction¹¹⁵

Another area of innovation regarding decentralized construction is the employment of additive manufacturing. Additive manufacturing utilizes an extrusion process, and a computer operated arm to lay down different materials in a process that prints a 3D object based upon a digital model. This technology has recently become more mainstream as hobbyists can now access and purchase small scale 3D printers at affordable prices. The question is, however, how 3D printing at the hobbyist level can become more applicable to construction at the building scale.

Recent innovations in 3D printing technology have demonstrated that 3D printing is now achieving new levels of effectiveness. McKinsley and Company, a firm that publishes quarterly reports on leading edge insights regarding innovations for use by senior management, elaborates on 3D printing.

¹¹⁵ Stephen Kieran and James Timberlake, *Refabricating Architecture : How Manufacturing Methodologies Are Poised to Transform Building Construction* (New York, N.Y. ; London: McGraw-Hill, 2004).

*The capabilities of 3-D printing hardware are evolving rapidly, too. They can build larger components and achieve greater precision and finer resolution at higher speeds and lower costs. Together, these advances have brought the technology to a tipping point—it appears ready to emerge from its niche status and become a viable alternative to conventional manufacturing processes in an increasing number of applications.*¹¹⁶

At the building scale a Chinese company, Winsun, demonstrated that it could 3D print ten homes in the span of twenty-four hours using extruded concrete in 2015.¹¹⁷ In 2014 Arup, a world leading design consulting firm has shown that 3D printing of structural steel is possible.¹¹⁸ Researchers at UC Berkley have demonstrated a process to get refined detail in 3D printed concrete.¹¹⁹ And lastly, Italian manufacturer 3ntr developed a system to print composite materials such as carbon fiber, fiberglass, and Kevlar which consist of a blend or arrangement of disparate materials.¹²⁰ With 3D technology on the rise, we may one day see potential applications in the construction of affordable housing.



Figure 4.5– Photo showing ten homes created by a 3D printer in twenty-four hours by a company called Winsun¹²¹

¹¹⁶ Daniel Cohen, Matthew Sargeant, and Ken Somers, "3d Printing Takes Shape," (2014), <http://www.mckinsey.com/quarterly/about-the-quarterly>.

¹¹⁷ "A Giant 3d Printer Builds 10 Houses in One Day," http://www.huffingtonpost.com/2014/09/08/3d-printed-houses_n_5773408.html.

¹¹⁸ Roy Scott, "Arup Develops 3d Printing Technique for Structural Steel," <http://www.archdaily.com/514003/arup-develops-3d-printing-technique-for-structural-steel>.

¹¹⁹ Adam Williams, "Berkeley Researchers Pioneer New Powder-Based Concrete 3d Printing Technique," (2015).

¹²⁰ Pamela Waterman, "3d Printing with Composite Materials," (2016).

¹²¹

A third consideration in decentralized construction is the rise of the maker movement. Makerspaces are collaborative environments established to empower everyday people to make things. These makerspaces often include equipment and tools to enable the creative interests of anyone who wishes to make something.¹²² According to Popular Science magazine, makerspaces have become more popular with approximately 1,400 active makerspaces. In the past decade, there has been an increase in makerspaces across the nation. In relating to the ADU, can there be a future where the makerspace becomes the place where the homeowner is able to make their own ADU in modular segments?

Innovations in decentralized construction can play an interesting role in the future of ADU construction. Who knows how these creative processes will change the construction market; shortened construction periods, lower labor costs, and increased profits from the ability to complete more projects annually are just some of the potential benefits of decentralized construction. These benefits would make the development of ADUs more desirable to homeowners and an even more desirable answer to the affordable housing problem.

Though the future is uncertain, this research has considered four issues relating to the development of ADUs: independent wastewater treatment, alternative transportation, renewable energy, and decentralized construction. Just as a decision support system would empower the homeowner to generate new affordable rental stock, these future considerations have the potential to enable the development of future ADUs. The Decision Support System will investigate, the current approach to ADU development and will also demonstrate how these future innovations and influences may become considerations in the design process.

¹²² "What Is a Makerspace," <https://www.makerspaces.com/what-is-a-makerspace/>.

CHAPTER 5 : PRECEDENT STUDIES

To effectively improve on a current model of ADU one must first gain a better understanding of the prior examples. In this section of the research, various preceding designs will be investigated and assessed for their successes and drawbacks. The successes can then be analyzed to see how they integrate into the proposed decision support system.

AHL ONE PERCENT PRO BONO ADU

In 2015, Architects Hawaii Ltd. (AHL) in conjunction with the Appleseed Center for Law and Economic Justice designed an ADU prototype as part of its one percent pro bono program. The project would feature a 340 square foot detached unit on lands owned by the Department of Hawaiian Home Lands (DHHL). This project presents an idealistic version of an ADU as it features many great amenities striving to meet standards established by the Living Building Challenge.¹²³ Though the location of the project and its success are unknown, the AHL one percent pro bono ADU project presents a conceptual model for comparison. The design was intended to be further expanded to create a predesigned model which, in partnership with Honsador Homes, would be mass producible. Honsador Homes is a local building materials company that also markets a line of prepackaged home kits. If the project became a successful kit home, it might have the potential to create a lasting impact on generating housing for the State.

¹²³ Architects Hawaii Ltd., 2015, <http://www.ahldesign.com/blog/2015/10/ahls-1-program-accessory-dwelling-unit-adu-project/>.

ACCESSORY DWELLING UNITS

SUSTAINABILITY COMPONENTS



- 1 **SOLAR PANELS**
A high-output, ultra-efficient, solar panel array will be installed on the sloped roof. Selected for its durability, ease-of-installation, and improved energy harvesting. The array will be connected to an inverter and a home battery system to provide off-the-grid electrical service and resiliency.
- 2 **HOME BATTERY SYSTEM**
Powered by inverter/charger technology, the home battery system was selected for its standalone ability, intelligent charging components and compact, low power-demand design. The battery will be installed in a sealed chassis to protect it from the harsh ocean environment.
- 3 **RAINWATER HARVESTING**
Rainwater will be harvested by the oversized roof, distributed by a traditional gutter system, and stored in a holding tank for single-occupant use. A three-stage water purification system will provide potable water to plumbing fixtures where it is needed.
- 4 **FUSHABLE COMPOSTING TOILET**
A self-contained, vacuum-flush, composting toilet will be installed in the bathroom. The sanitation system uses much less water than conventional flush toilets and converts waste into compost through advanced automatic aeration and natural microbe action. Compost will help support sustainable gardening practices, which are already being implemented on site.
- 5 **BIOPHILIC DESIGN**
Articulating the relationship between nature, human biology and the built environment, biophilic design reduces stress and increases clarity of thought. Several light fixtures will be constructed of botanical and oceanographic remnants, recalling the site's context at the base of the Ko'olau and adjacent to the ocean. Door pulls, towel bars and common hardware elements will be replaced with driftwood gathered by marine biologists. CMU piers supporting the floor framing system will be clad in earthen material, sand, seashells and rock remnants found on site.

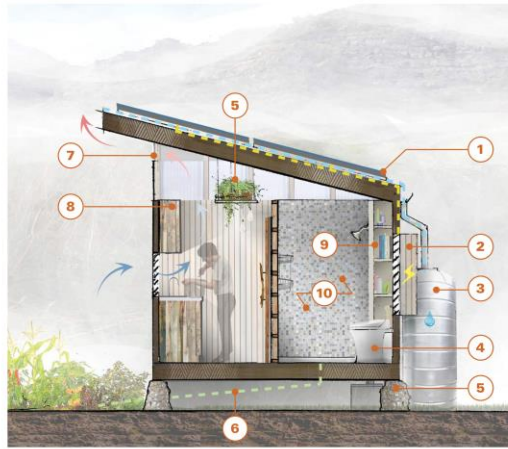

- 6 **GREYWATER**
Greywater harvesting will support irrigation activity at the garden and will eliminate the need to irrigate using costly drinking water. Collection will occur at the compact laundry machine, bathroom sink and shower. Use of biocompatible soaps and detergents will reduce the need for water treatment prior to release in the garden. Harmful pathogens, commonly found at the kitchen sink, will be collected as blackwater and distributed to an on-site septic tank.
- 7 **PASSIVE COOLING**
By incorporating natural trade wind patterns and stack effect principles into the overall design, no active mechanical system will be needed. A crawl space under the structure keeps the underside of the Accessory Dwelling Unit cool and well ventilated. Jalousie windows and large sliding doors were specifically positioned to allow cool ocean breezes to emanate through the interior. Situated just below the roof line, an array of steel mesh openings allows the rising warm air to escape to the outdoors. Finally, a centralized ceiling fan helps increase air flow during stagnant days.
- 8 **REPURPOSED MATERIALS**
All built-ins, casework and kitchen cabinets will be constructed of repurposed, upcycled, pallet wood. Typically found at large distribution centers, loading docks and supply warehouses, pallet wood is an attractive and renewable resource that is commonly lost to local landfills. In lieu of purchasing cabinets from "big box" manufacturers, a local pallet wood craftsman has been commissioned for this project, which adds to the economic vitality within our community.
- 9 **WASTE ELIMINATION**
Diverting construction waste and debris from our island's growing landfill is a sustainable practice often neglected or sacrificed in our industry. Every design decision, therefore, from site planning to building layout to finish material selections and detailing, was based upon the team's collective goal of less than 2% material waste. Material waste leftover on site will be used to skin doors, create shelving and build furniture. Waste items that cannot be repurposed will be donated to and upcycled at Re-use Hawai'i.
- 10 **RE-USE HAWAII**
Re-use Hawai'i is a vibrant, non-profit organization, working to eliminate waste through building material reuse and upcycling. In lieu of purchasing new materials and finishes, certain bathroom fixtures, kitchen appliances and material finishes, including all ceramic tiles, will be procured at Re-use Hawai'i's warehouse, which is located just outside of downtown Honolulu.

Figure 5.1– Section diagram of the AHL one percent pro bono ADU in respect to its sustainable features

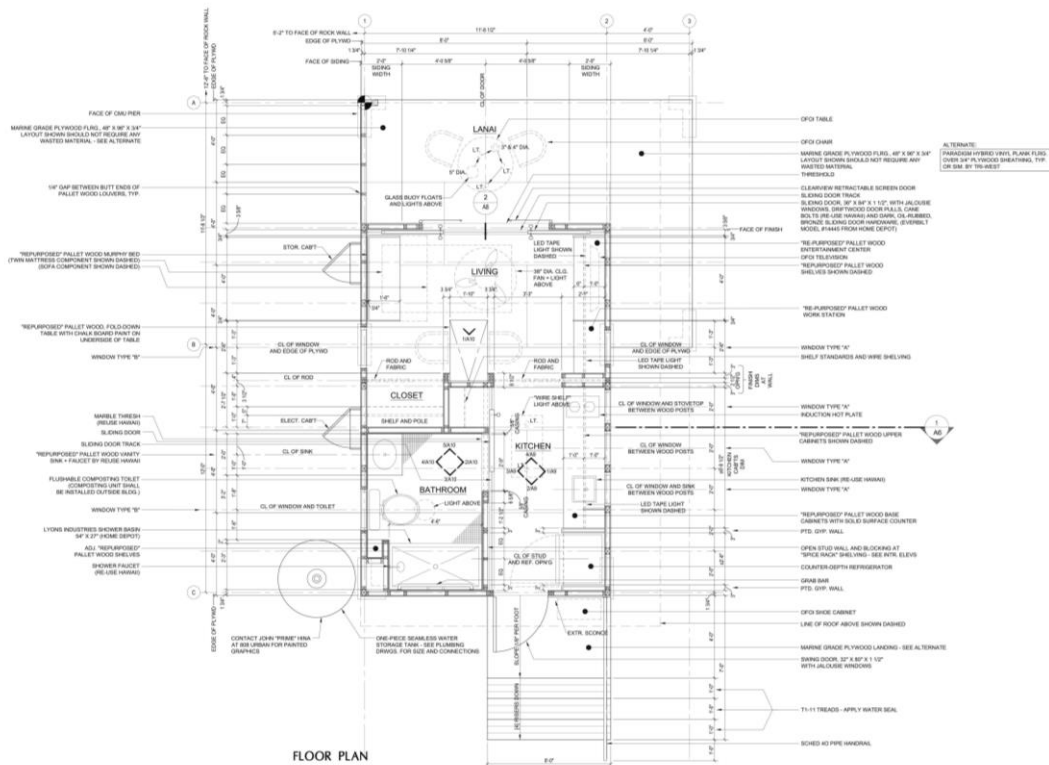

Figure 5.2– Plan drawing of the AHL one percent pro bono ADU design

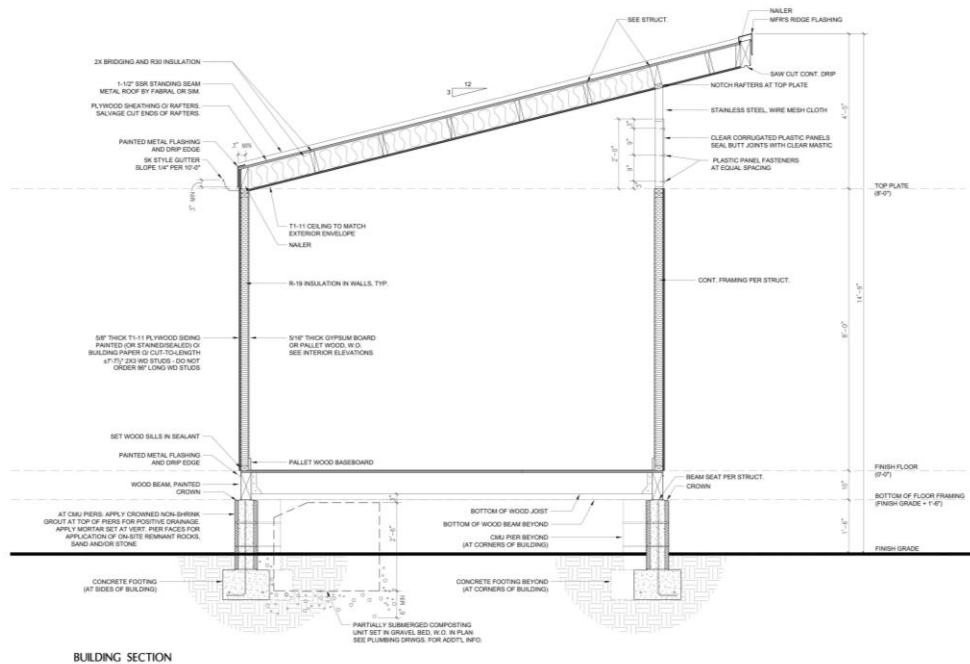

Figure 5.3– Section view of the AHL one percent pro bono ADU

What differentiates this prototype from other predesigned options is this design included additional “living building” features integrated into the package. The Living Building Challenge is a certification program that sets high standards for construction projects. If the project meets the requirements, it is certified and acclaimed as a satisfactory project. [The] “Living Building Challenge uses the metaphor of a flower because the ideal built environment should be as simple and efficient as a flower.”¹²⁴ In this model the goal is to create buildings that are:

- *Regenerative spaces that connect occupants to light, air, food, nature, and community.*
- *Self-sufficient and remain within the resource limits of their site. Living Buildings produce more energy than they use and collect and treat all water on site.*
- *Creating a positive impact on the human and natural systems that interact with them.*
- *Places that last. Living Buildings need to be designed to operate for a hundred year’s time.*
- *Healthy and beautiful.*¹²⁵

¹²⁴ International Living Future Institute, "Living Building Basics," <https://living-future.org/lbc/basics/>.

¹²⁵ Ibid.

In the AHL one percent pro bono ADU, the “living building” features included in the design are: solar panels, home battery system, rainwater harvesting, flushable composting toilet, biophilic design, greywater reuse, passive cooling, repurposed materials, waste elimination, and material re-use.¹²⁶ Figure 5.1 depicts how the designers integrated sustainable features in the ADU design. Although this prototype is idealistic, the design should serve as the high standard for other designs to strive for and surpass in sustainable measures.

The AHL one percent pro bono ADU is a unique prototype. Expanding on the design may require modification to accommodate a variety of locations. Designers would have to employ a degree of modularity and customization to make the widespread application of the design possible without every ADU being replicated throughout the neighborhood. Given the site specificity of the prototype, the question is whether the design could have the same relationship to other locations in a prefabricated mass produced way. Overall, however, the design is exemplary in how to approach sustainability through a minimal design.

OHANA KIT

Another applicable prototype is the Ohana Kit by Hawaii ADU. This innovative prefabricated design kit utilizes a steel container frame and features a modular construction method. This decentralized construction option uses a volumetric modular system where the modular home is fabricated in the mainland and then shipped to Hawaii.¹²⁷ Through this method, they avoid issues with labor shortages and upcharges during busy construction periods. However, because the Hawaii ADU produces the modules off the island, transportation and shipping charges are a cost factor. Further research into local sustainable production systems is needed to ensure self-sufficiency in construction.

Compared to the AHL one percent pro bono ADU, the Ohana Kit is a step further in modularity as it applies to a variety of sites. This prototype employs a range of models that cater to various situations. The company utilizes five base models: Maui Spacious,

¹²⁶ Ltd.

¹²⁷ Ohana Kit ADU & Home, "Introducing Ohana Kit by Hawaii ADU," <http://www.hawaiiadu.com/>.

Kauai Spacious, Molokai Deluxe, Lanai Deluxe, and the Haleakala Loft. From these base models, other customizations can be made to personalize the design for the homeowner. Customizations include varying types of exterior siding, different roof slopes, various deck sizes, different roof sizes, and an extensive range of interior components. For additional customization, the company will work with the homeowner.¹²⁸

Unlike the AHL one percent pro bono ADU, these models do not feature the sustainable features to meet the Living Building Challenge. And though the Ohana Kit has more options than the AHL one percent pro bono ADU, the Ohana Kit is still limited in design beyond its five model selection. The Ohana Kit, however, excels as a business model for providing affordable housing in a market dependent upon a limited labor force. Because the Ohana Kit is fabricated off-site in a controlled manufacturing environment, the ADU is not subject to the variability and potential errors of on-site fabrication. The fabrication is double edge sword, however, because off-site fabrication methods might not adjust as easily to unusual construction circumstances as on-site construction.

¹²⁸ Ibid.



Figure 5.4 – Plan drawing of the various OhanaKit models: Maui Spacious (upper left), Molokai Deluxe (upper right), Lanai Deluxe (bottom left), Kauai Spacious (bottom right).¹²⁹The Hawaii ADU company website advertises the estimated costs for the construction of their ADU

¹²⁹ Ohana Kit ADU & Home, "Introducing Ohana Kit by Hawaii Adu," <http://www.hawaiiadu.com/>.

models starting at \$59,500 and range between \$150 to \$250 per square foot.¹³⁰ The cost of the ADU construction is necessary to ADU development. The Ohana Kit provides homeowner a realistic view of what the estimated building cost for the structure but is not clear as to what is fully included in the advertised cost. The company website is helpful to the first time developer in deciding on whether to construct an ADU by displaying its floor plans, included amenities, and estimated costs. The Ohana Kit provides a high value to customers by providing a quality product at a reasonably affordable price. The owner can request for an ADU and, similar to an architect, the company may work with the client to adjust their models to accommodate the owner specific needs to some extent. This methodology allows for a quick and cost effective way to develop affordable housing.

SANTA CRUZ ADU PROGRAM

In 2003 the City of Santa Cruz municipality passed an ordinance allowing for the construction of ADUs.¹³¹ As a result of the Santa Cruz program, there are some lessons to learn regarding the design and implementation of ADUs. These lessons include the role of the homeowner regarding the development of the ADU, the relationship of the site to the ADU, and the varying types of ADUs.

When the City of Santa Cruz passed the ADU ordinance, they also released an ADU manual. In the handbook, they outline a procedure for the homeowner to follow in the pursuit of an ADU. The process involves “getting started,” “designing your ADU,” and “being a project manager.” The first step, “getting started,” includes getting a basic understanding of what an ADU is and quickly assessing if the property in question qualifies. The second phase, “designing your ADU,” is insightful in that the manual provides a small catalog of ADU types and their relationship to common sites. The last step, “being a project manager,” explains the homeowner’s active role in the construction and management of the development project.¹³² Before considering the ADU, the owner

¹³⁰ Home, "Introducing Ohana Kit by Hawaii Adu."

¹³¹ City of Santa Cruz, "Accessory Dwelling Unit Program," <http://www.cityofsantacruz.com/departments/planning-and-community-development/programs/accessory-dwelling-unit-development-program>.

¹³² "Accessory Dwelling Unit Manual," (2003).

may be unaware of the necessary skills he/she will need or the responsibilities he/she will need to assume in the development process. The manual makes it clear the homeowner will be an active participant in the process and needs to be informed to fulfill their role of a property developer.

In the design component of the manual, there are different prototypes which the City of Santa Cruz has investigated. Amongst these prototypes are the “Detached ADU,” the “ADUs on Alleys and Corner Lots,” and “Attached ADU.” For each prototype, the manual shows varying conditions and applicable variations. Additionally, the manual expands on how each version relates to a specific context. These contexts include “Traditional Neighborhoods,” “Transitional Neighborhoods,” and “Post-war Neighborhoods.”¹³³ Once the homeowner picks the general prototype, the manual explains the homeowner’s responsibility to hire an architect for the specifics of relating the design to the particular site in question.¹³⁴

The process of informing the homeowner is an interesting approach to ADU construction. With commercial projects, it is the role of the developer to address all issues or consult specialists in the respective areas. As the homeowner is essentially the developer of a small construction project, he/she will need to understand their role and the ramifications of their decisions. The Decision Support System which this research investigates attempts to build off the idea of empowering the homeowner. The support system, however, attempts to identify further the clarity of design which the owner seeks while making the additional proactive future design considerations.

¹³³ Ibid.

¹³⁴ Ibid.

Santa Cruz Neighborhood Contexts

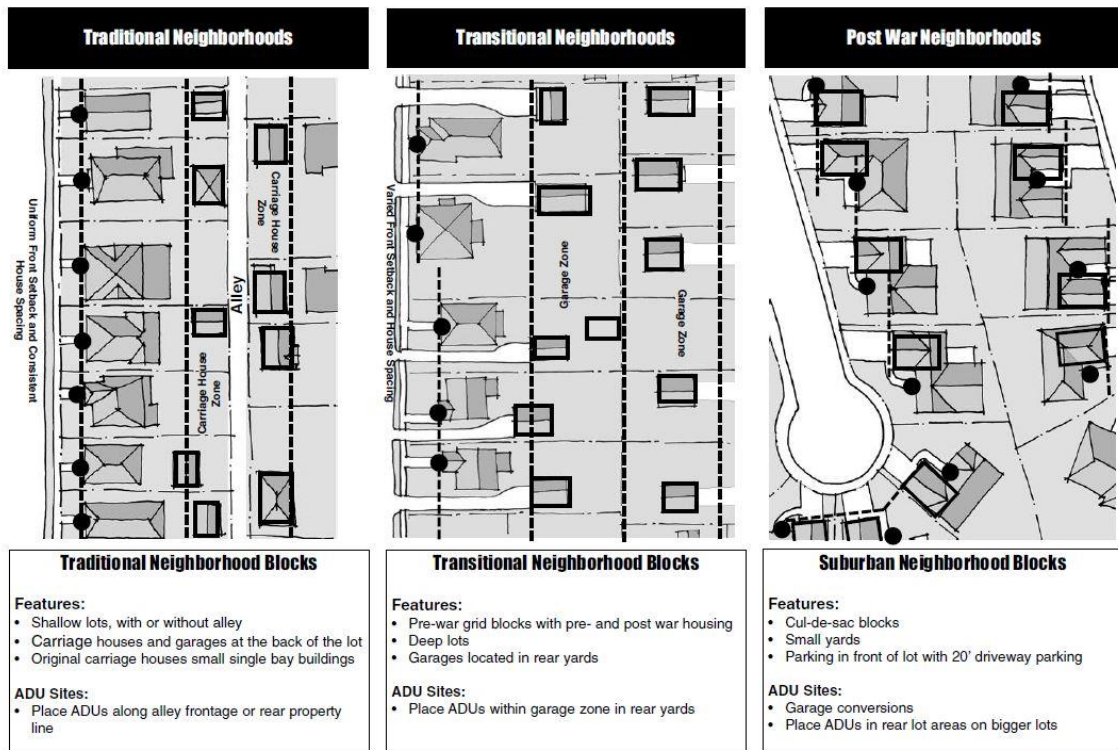

Figure 5.5– Diagram depicting ADU placement on site in relation to neighborhood layout.¹³⁵

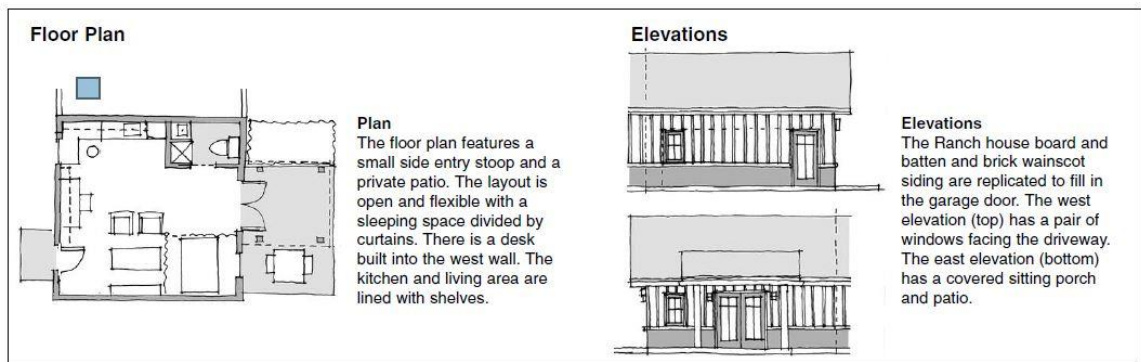

Figure 5.6– Diagram depicting the carport ADU prototype used in the Santa Cruz ADU program booklet.¹³⁶

¹³⁵ Ibid.

¹³⁶ Ibid.

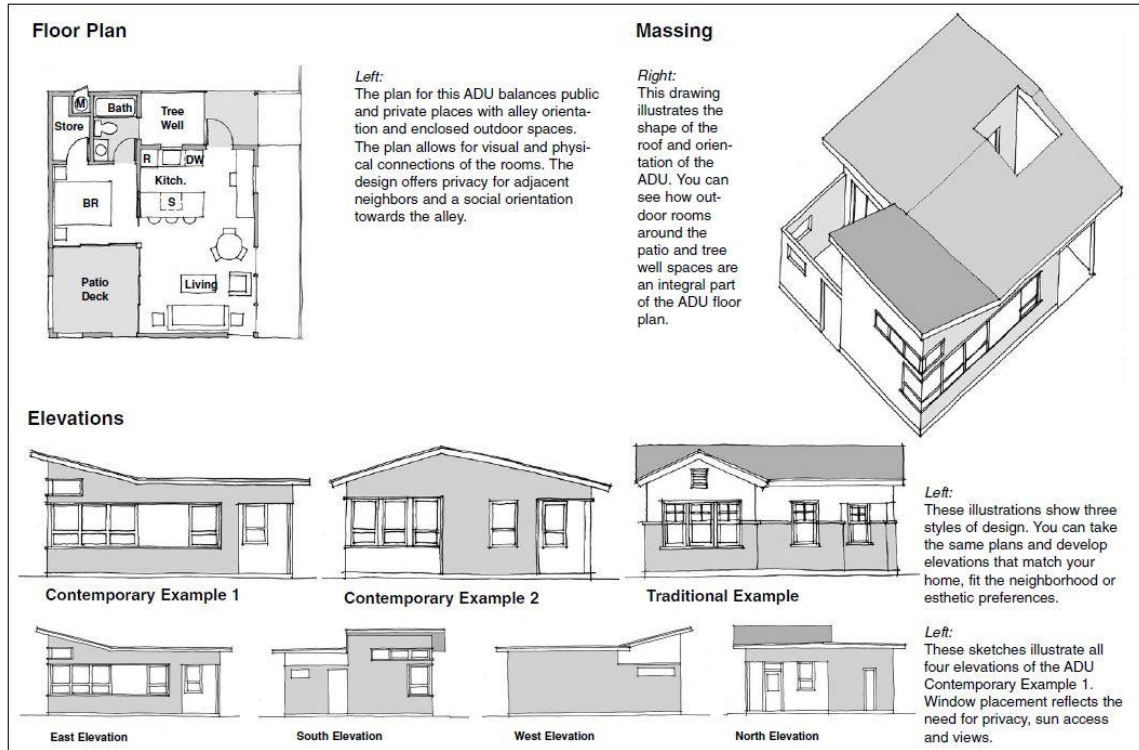

Figure 5.7- Diagram depicting a detached ADU prototype used in the Santa Cruz ADU program booklet.¹³⁷

Additionally, the Santa Cruz ADU program also provides insight into dealing with illegal, unpermitted units. Having passed the ADU regulations, the city had problems with previously constructed unpermitted dwelling units. The city decided that the best approach would be to pass a rental inspection ordinance that would require homeowners to bring unpermitted units up to governing standards and obtain an after-the-fact permit. The consequence to not abiding would be the demolition of the property and fines to the owner. This process became problematic as many times individuals were living in unpermitted residences that they were unaware. Thus the demolition of the structure could result in an individual losing a home. The ADU law made it possible to improve affordable housing, but the inspection law would undermine the efforts by reducing supply and increase rents. "...ADUs have made for "grassroots affordable housing," and that cracking down on them takes that away."¹³⁸

¹³⁷ Ibid.

¹³⁸ Jacob Pierce, "Unit Shifter," <http://goodtimes.sc/santa-cruz-news/unit-shifter/>.

MICRO COMPACT HOUSE

The Micro Compact House (MC-H) is a study in efficiency regarding the essential size of space needed by an occupant. The micro compact home is a small 76 square foot dwelling unit that addressed a need for short term stay accommodations. Created by Professor Richard Horden and his students at the Technical University Munich, despite its small size the MC-H still boasts a large number of extra amenities. This prototype contains two small double beds, storage, a sliding table, a flat-screen TV, a shower and toilet cubical, a kitchen area, air conditioning, water heating, a thermostat controlled air heating system, and the internet.¹³⁹ It is incredible how such a tiny unit can contain so many features.

The MC-H is made from timber framing and weighs about 2.2 tons. In some instances, an aluminum frame is used instead which allows the MC-H to be carried by helicopter to its location. The unit produced off-site in a factory. During fabrication, the build site undergoes preparations for the necessary foundation and support structures.¹⁴⁰ In a quick and delicate fashion the unit is hoisted into place via crane and then attached to the ground structures. This production model demonstrates a fast-track approach to generating housing units.

The MC-H dwellings can be used to create a community by setting them up in a configuration to provide a multi-dwelling variation. In 2005, the MC-H was used to create O2 Village, which features seven units. These units were used to house six students and their professor. Another community design for the MC-H dwelling is the Tree Village. This variation utilizes an arrangement of steel tubes as a superstructure on which to place the individual units.¹⁴¹ Like a tree, the project features a vertical alignment providing many units with the least amount of contact with the ground.

This precedent demonstrates the core needs of a dwelling relating to the amount of space used. The ADU will be many times larger, about 400 square feet; but, ideally, it can house an individual in less space. In the design of small spaces, it is necessary to

¹³⁹ Micro Compact Home Ltd., "Micro Compact Home," <http://www.microcompacthome.com/>.

¹⁴⁰ Ibid.

¹⁴¹ Ibid.

maximize utility and have space be multifunctional. In the MC-H, the design makes efficient use of space by storing and compartmentalizing various components such as tables and beds. The homeowner investigating the design of an ADU may wish to follow similar practices to reduce the square footage of the proposed unit.

CHAPTER 6 : SUPPORT SYSTEM DESIGN LENSES

Affordable housing is an issue for the State of Hawai'i. A capable new law has the potential to create an impact in adding to the current housing stock. The ADU law enables the homeowner to generate infill development in residential neighborhoods through the construction of ADUs. This chapter depicts the early thinking and processes that occur in the preliminary stages of the Decision Support System. The goal of the decision support system is to generate a workflow from which to make informed development decisions regarding an ADU.

The pursuit of an ADU needs to be beneficial for the homeowner if he/she is going to invest a substantial amount of time and capital into the project. The homeowner must assess the available options and gain insight into the development process. At the onset of the project, the homeowner has three potential options. The owner can either do nothing, develop an ADU, or develop an illegal ADU (iADU). In the pursuit of an ADU, the incentives include the potential to earn additional income from the rented ADU, more living space for extended family, and a place for elderly family members.¹⁴² There are, however, a few drawbacks which include design fees, permitting fees, frustration created by a lack of understanding in the design and development process, and the enormous cost of the overall project. In the pursuit of the iADU, the benefits also include the potential to earn additional income from the rented iADU, more living space for the extended family, and a relatively fast, low consequence way to get the whole project done. The drawbacks to the iADU are potential fines due to unpermitted work. And, at the point of sale or appraisal, consequences may range from after-work permits to reconstruction or demolition of the unpermitted structure.

¹⁴² Karen Chapple, "Studying the Benefits of Accessory Dwelling Units," (2011), <https://frameworks.ced.berkeley.edu/2011/accessory-dwelling-units/>.

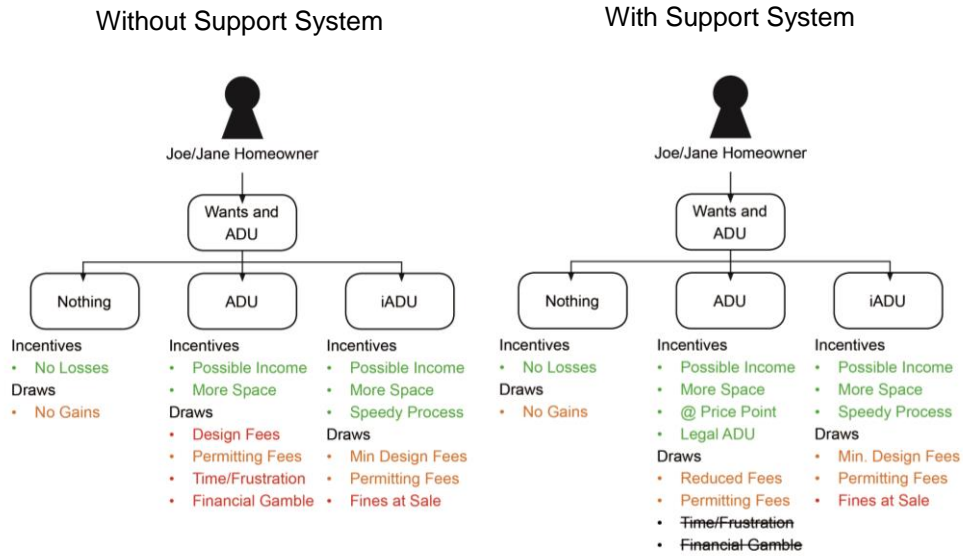

Figure 6.1 – Diagram depicts an improvement towards the decision to pursue an ADU through the use of a support system

What the decision support system offers is a way to make the ADU equally or more advantageous than the iADU by removing some of the drawbacks associated with the ADU. As it stands now, the iADU is more beneficial as there are few immediate drawbacks. Often, homeowners are unaware of the long-term disadvantages to an iADU or do not realize the potential financial damage to their loved ones an illegal ADU can cause in the future. Traditionally, there are two methods of dealing with iADUs. The first solution is to punish the owners of the illegal units by tearing down unpermitted ADUs. This method is intended to punish the owner who built the illegal unit. But many homeowners in Hawai'i have purchased homes with illegal ADUs "as is." While these owners are guilty of buying an illegal dwelling, they did not make the decision to build it any more than owners who inherit an iADU. This solution, also, has additional drawbacks besides the financial loss to the homeowner. As the Santa Cruz case demonstrated, the demolition of unpermitted work led to a further decrease in housing.

The second solution to the iADU problem is to make the ADU competitive and easier to pursue. This scenario begs the question, how can the ADU development process become more beneficial to the homeowner? The Decision Support System proposes to reduced design fees associated with conceptual design, clarify the design and development process for the owner, and explain construction costs to make the

homeowner aware of expenses in the design and construction process. By doing these three things, the homeowner can make an informed decision as to whether an ADU is in their best interest.

In the clarification of the design and development process, the Decision Support System helps homeowners generate viable conceptual schemes and identify low-cost alternatives. Giving homeowners a decision-making tool, like the Decision Support System, allows homeowners to decide on a design with features specific to the owner's needs within their cost range. If the construction site has specific needs, the homeowner may be able to adapt his or her design to accommodate the site's needs. If not, the homeowner will know they need the help of a professional and the reason they need help. By educating and empowering the homeowner, the decision support system also empowers designers and architects to assist their clients by creating a better-informed client with a clearer more realistic design idea. The clarification reduces wasted effort in the refinement of undesired alternatives driven by naive and unrealistic expectations. For smaller budgets, clear, realistic design expectation is particularly important to optimize the design process. The goal of the ADU law is to generate affordable housing stock rather than overcharging and frustrating homeowners.

Before addressing the workflow itself, this research will investigate seven considerations, or lenses through which informed decisions can be made about the design process. These lenses are view/vista, accessibility, ventilation, structure, privacy, cost, and lighting. Each lens is essential to the layout and success of the ADU's design. Though each lens may not apply to all designs, examination through these lens is an important part of the design process and facilitates decisions made in the Decision Support System. Additionally, the relationship between these lenses needs further investigation as the individual weight of each consideration is not entirely known. As a subject for further research, a mathematical framework for design could be developed to supplement the workflow set up in this decision support system. For this study, the considerations will receive either a positive, negative, or null value. The option that receives the highest value will move to the next steps. The pursuit of one option over the other does not invalidate the other options. The option is just less prioritized in regards to the other seven lenses. The use of these lenses is not to create an all-inclusive design

methodology but rather to create a support tool for homeowners to pursue informed practical design alternatives.

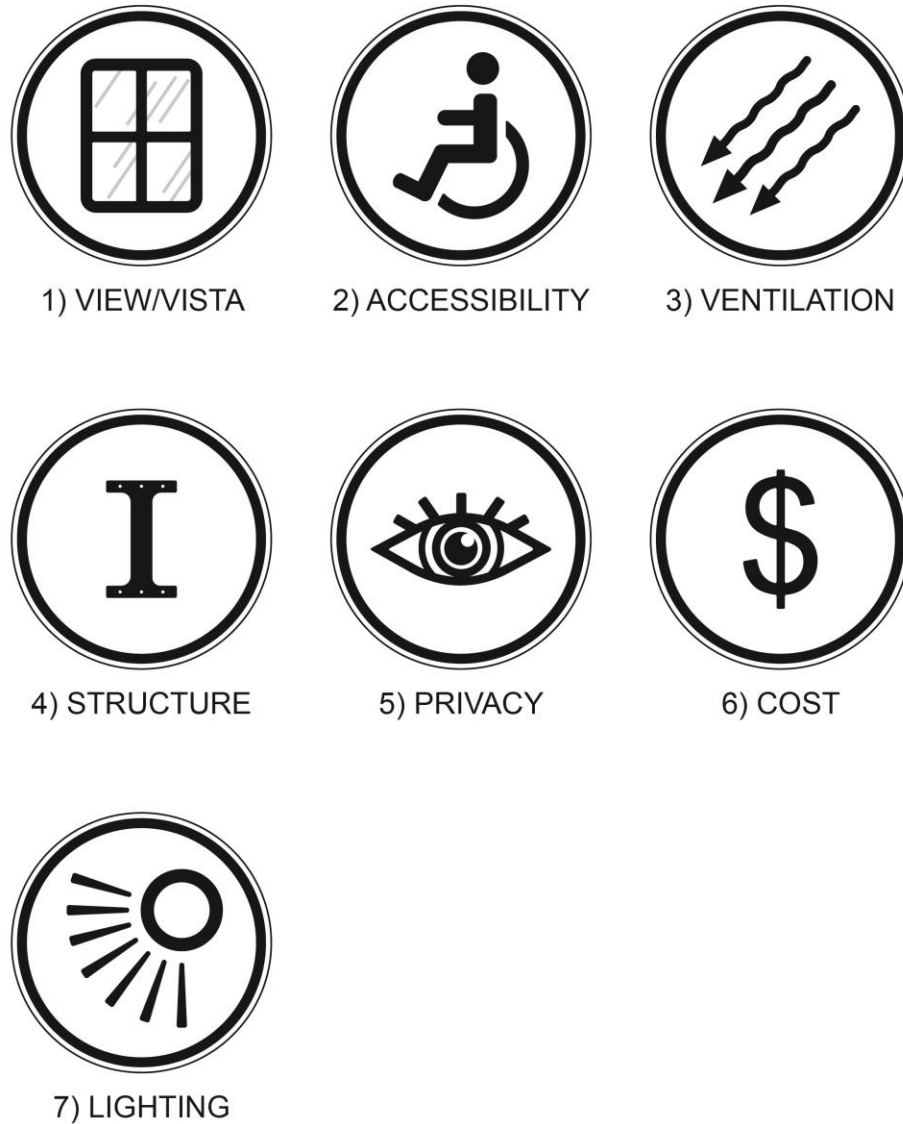

Figure 6.2– A graphic representation of the seven design lenses to be used in the decision making process outlined in the following sections.

VIEW/VISTA

The first of the lenses is view/vista. The role of view or vista in design is important in that it provides a clear visual relationship between features in the design. In “The Concise Townscape,” a book by Gordon Cullen which sparked a movement in respect to urban planning in the middle of the 1900’s, the author discusses the experience of a pedestrian as he moves throughout an urban layout. His essay examines the notion of serial vision. “Although from a scientific or commercial point of view the town may be a unity, from our optical viewpoint we have split it into two elements: the existing view and the emerging view.”¹⁴³ Cullen’s notion of serial vision suggests that individuals rely on an expectation of an emerging view based upon the current view. A visual orientation to passage suggestive of another destination creates a form of wayfinding connecting one’s present position to a navigational path to a future position. Thus, “[v]isual orientation is an essential design element that serves to provide both visual and physical definition for a pedestrian’s, cyclists or motorist’s travel through a community.”¹⁴⁴

Francis Ching, a retired emeritus professor at the University of Washington, discusses the role of the window in “Form, Space, and Order,” a textbook used readily by architecture schools.

*Another quality of space that must be considered in establishing openings in the enclosure of a room is its focus and orientation. While some rooms have an internal focus, such as a fireplace, others have an outward orientation given to them by a view to the outdoors or an adjacent space. Window and skylight openings provide this view and establish a visual relationship between a room and its surroundings.*¹⁴⁵

The role of the view creates a sense of orientation within an overall framework of the built structure.

¹⁴³ Gordon Cullen, *The Concise Townscape* (1961).

¹⁴⁴ Ibid.

¹⁴⁵ Francis D. K. Ching, *Architecture, Form, Space & Order*, 2nd ed. ed. (New York ; London: Van Nostrand Reinhold, 1996).

Additionally, views have an effect on the emotional response by individuals. The view creates either a satisfactory positive response or a negative adverse response. The type of reaction depends on what is being framed or seen. When going to a hotel, views play a role in the room valuation. A guest pays more for a room with an ocean view versus a room with the view of another building. Views affect the way we feel in space.

ACCESSIBILITY/EGRESS

The second lens is accessibility/egress. Accessibility is an important aspect of architectural design and planning, governed by specific codes. In the City and County of Honolulu, various codes regulate construction. These codes include the International Building Code 2006 (IBC 2006), International Residential Code 2006 (IRC 2006), International Existing Building Code 2006 (IEBC 2006), and other international codes relating to fire safety systems, plumbing systems, electrical systems, and energy conservation.¹⁴⁶ The State requires state government buildings and facilities comply with the current American Disabilities Act (ADA) Guidelines, ADA 2010.¹⁴⁷ In IBC section 1101.2, there is also an additional document which governs accessibility, International Code Council (ICC) A117.1. "Buildings and facilities shall be designed and constructed to be accessible in accordance with this code and ICC A117.1."¹⁴⁸ The architect and his team of consultants are the professionals responsible for assuring that the building design follows and comply with these codes.

For a homeowner creating a conceptual design for an ADU, the task may seem daunting under so many regulations. However, several general notions work as a rule of thumb for homeowners and simplify the process. First, the IBC section 1103.2.4 states that "Detached one- and two-family dwellings and accessory structures, and their associated sites and facilities, are not required to be accessible." Secondly, accessible is outlined in IBC section 1102 to mean "A site, building, facility or portion thereof that complies with [Chapter 11 in the IBC]."¹⁴⁹ Simply put, the IBC accessibility requirements do not apply to

¹⁴⁶ State of Hawaii, "State and County Building Code Status," <http://pwd.hawaii.gov/state-county-codes-status/>.

¹⁴⁷ "Chapter 12 Facility Access," Department of Health Disability and Communication Access Board.

¹⁴⁸ International Code Council, *International Building Code* (2006).

¹⁴⁹ Ibid.

the ADU. Not having to conform to accessibility regulations is good news to some homeowners. However, when investing resources into such a major property improvement as an ADU, the homeowner needs to think like a developer or an architect who designs with the best long-term functionality of the property in mind. Homeowner-developers should, to the best of their ability, incorporate accessibility measures. Accessibility standards exist to assure individuals will have access to the spaces, functions, and features of buildings and facilities constructed.

Means of egress, however, is not an element of accessibility and is governed by another chapter in the IBC. The IBC Section 1002 defines “means of egress” as, “A continuous and unobstructed path of vertical and horizontal egress travel from any occupied portion of a building or structure to a public way. A means of egress consists of three separate and distinct parts: the exit access, the exit, and the exit discharge.”¹⁵⁰ A few general rules of thumb apply to the design of the ADU.

- Corridors with a dwelling unit should not be less than 36 inches (IBC Section 1017.2)
- Exit passageways should not be less than 36 inches (IBC Section 1021.2)¹⁵¹
- The number of doors required for buildings serving fewer than 500 persons requires a minimum of two exits (IBC Section 1019.1)¹⁵²
- (IBC Section 1015.2.1) Where two exits are required they are to be placed, “...not less than one-half of the length of the maximum overall diagonal dimension of the building or area to be served measured in a straight line between exit doors or exit access.”¹⁵³
- (IBC Section 1014.2) A means of egress cannot pass through “kitchens, storage rooms, closets or spaces used for similar purposes.”¹⁵⁴

Other rules in the IBC apply, but for conceptual purposes, following these rules can elicit a conceptual scheme. Moving beyond the conceptual plan, the homeowner needs to consult a licensed profession to assure that the design meets all other requirements.

¹⁵⁰ Ibid., 202.

¹⁵¹ Ibid., 225.

¹⁵² Ibid., 223

¹⁵³ Ibid., 220

¹⁵⁴ Ibid., 218

Accessibility and egress regulations assure that a minimum standard of care occurs to ensure functionality and safety for the occupants of the design. A conceptual scheme needs to consider basic functionality and ask simple questions regarding the use of the building. Below are some basic questions to consider.

- How does an individual get in and out of the space?
- Is the path in and out or connecting spaces wide enough? (consider that moving furniture in and out of a room will require a certain amount of clearance; typically 32" minimum)
- Which way does the door open and does it block or conflict with the use of any area or path?
- When considering non-required accessibility, how does a wheelchair navigate the space?
- When considering non-required accessibility, can the wheelchair turn around in the space?

VENTILATION

The next lens to consider is ventilation. The location and size of openings in the exterior walls as well as the mechanical systems manipulate the passage of air in, around, and across space. The flow of air is a component in establishing a level of inner air quality (IAQ) which, in turn, has health implications. Thus, the IBC sets strict standards for the ventilation within a space. IBC Section 1203.1 states, "Buildings shall be provided with natural ventilation in accordance with Section 1203.4, or mechanical ventilation in accordance with the International Mechanical Code."¹⁵⁵

Natural Ventilation relies on passive wind effects the cooling of space. In this approach, "[n]atural ventilation of an occupied space shall be through windows, doors, louvers or other openings to the outdoors." Further, there are square foot requirements for passively ventilated openings to assure adequate ventilation of space. "The minimum openable area to the outdoors shall be 4 percent of the floor area being ventilated." Ventilation passing through an adjacent room before entering the target room require an

¹⁵⁵ Ibid., 249.

opening between the two spaces of 8 percent of the floor area or no less than 25 square feet.¹⁵⁶

Considering a passive system, one may wish to assess the direction of wind source based on the location. In Hawaii, the dominant wind pattern is the Trade Winds which originate in the North/Northeast flowing across the Hawaiian Islands. The less dominant wind pattern is the Kona Winds which originate in the South. The Kona winds are often humid and muggy.¹⁵⁷ A passive wind system will wish to open to the dominant wind pattern leaving openings in the North/Northeast direction. Additional fenestration should be included on another exterior surface to allow for cross ventilation.

The International Mechanical Code strictly regulates mechanical ventilation systems. One key feature homeowners should pay attention to is “[r]ooms containing bathtubs, showers, spas and similar bathing fixtures shall be mechanically ventilated in accordance with the International Mechanical Code.”¹⁵⁸ The regulation ensures that bathing accessories that are generating a significant amount of steam and moisture have a mechanical method to drive the warm moisture out to prevent the growth of mold.

STRUCTURE

The structure is the next lens. The structural engineering profession strictly monitors structural design of a building. The structure is an issue of liability and life safety. The homeowner should rely on a licensed structural engineer. The role of the building structure is to resist forces on the building. The greater the force, the more robust the structure needs to be. The rule of thumb for structure for small buildings, designers, pay attention to three primary forces which include gravity, wind, and uplift. Gravity acts to pull constructed elements back down to the ground. Wind force pushes the building from the side. Lastly, wind flowing over the building pulls the roof structure upwards generating uplift.¹⁵⁹ Additionally, materials have physical properties including weight,

¹⁵⁶ Ibid., 250.

¹⁵⁷ John Derrick, "Hawaii Weather and Climate Conditions," http://www.hawaii-guide.com/content/posts/hawaii_weather_and_climate_patterns.

¹⁵⁸ Council, *International Building Code*.

¹⁵⁹ "Bcgb4010a Apply Structural Principles to Residential Low-Rise Constructions," https://www.dlsweb.rmit.edu.au/toolbox/buildright/content/bcgb4010a/comp_index.htm.

tension strength, and compression strength. Tension strength is the ability for a material to be pulled apart and compression strength is the capacity to resist being crushed under a force.¹⁶⁰

Both the concepts of tension and compression come into play in the behavior of a beam or spanning member. Though specific details regarding the actual span about the material properties and the loads applied to them are rather complicated, a simple rule-of-thumb approach can be used to assess roof structures. In *Building Structures Illustrated* and *Architecture Studio Companion* the tables provided related average beam span distances and beam type and depth. The homeowner/developer can use these straightforward charts to size the necessary structure needed. Though this will not give a very precise solution, the tables can provide a basis on which to continue refinement of the structural design.

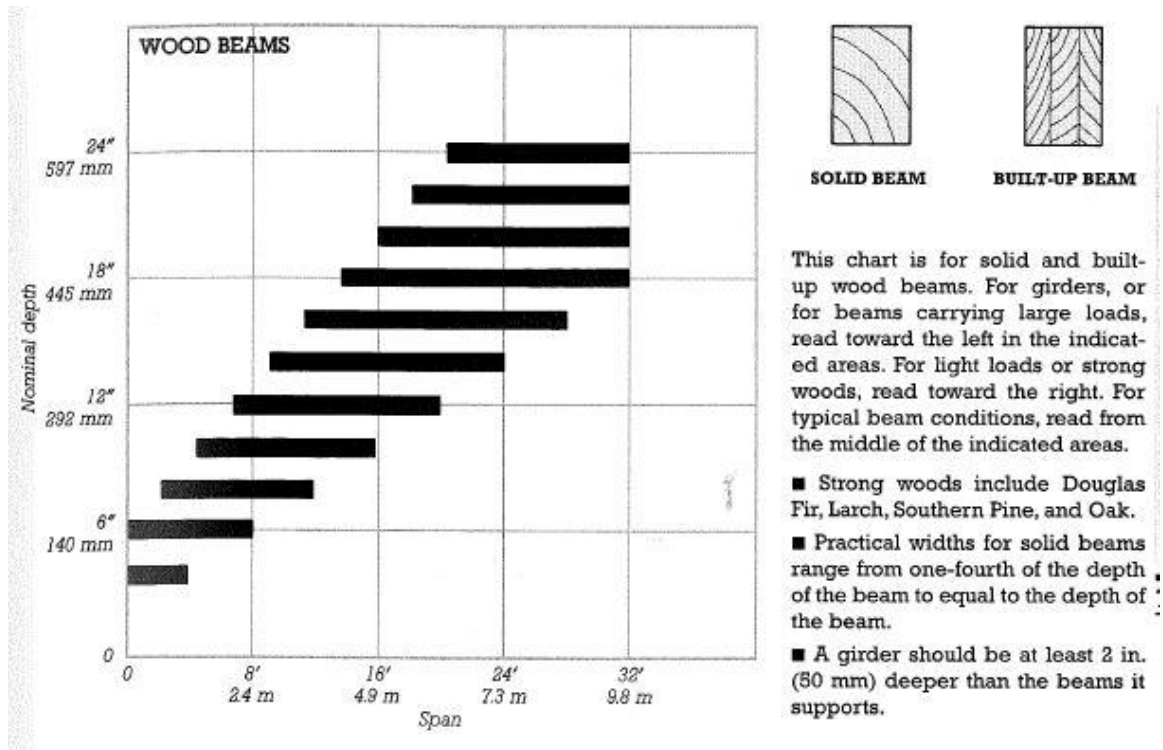
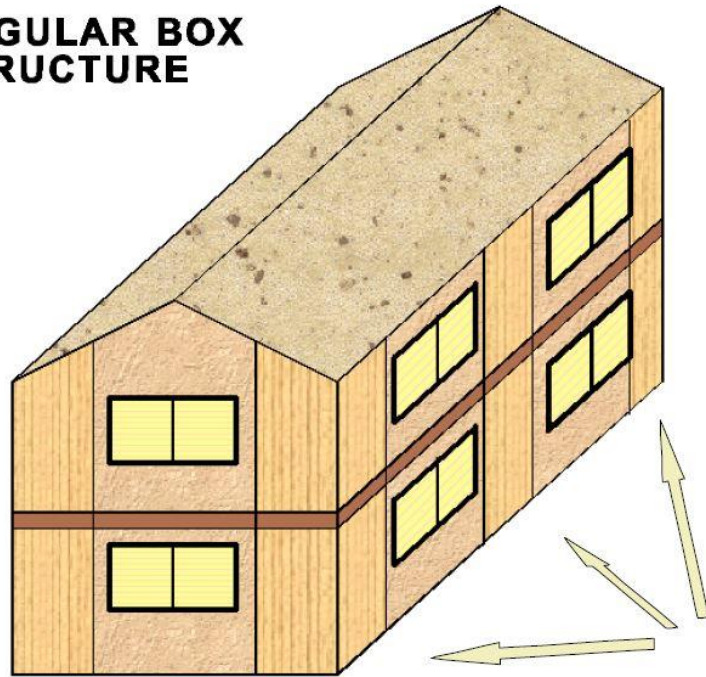

Figure 6.3- Sizing chart for wooden beams relating depth of beam to span distance.¹⁶¹

¹⁶⁰ Robert Lamb and Michael Morrissey, "How Bridges Work," (HowStuffWorks.com).

¹⁶¹ Edward Allen and Joseph Iano, "The Architect's Studio Companion," (Wiley, 2011).

REGULAR BOX STRUCTURE



EVEN DISTRIBUTION OF SHEAR WALLS

Fig.3.2 - Location of Shear Walls

Figure 6.4— A diagram showing a placement strategy for shear walls on a basic box structure design.¹⁶²

Lateral forces affect the building from the side. They are usually a result of earthquake and wind forces acting on the building. To counteract lateral loads, buildings are usually designed with shear strength. In a small wood framed home various methods can be employed to increase the shear capacity of the home. A common practice is the use of structurally enhanced sheathing over wooden frame members.¹⁶³ For specifics the homeowner is advised to consult a structural engineer but as a general consideration, blank areas of wall need to be placed on the exterior or interior of the building in the two primary directions of the building. The blank areas can be reinforced with structural sheathing which will resist shear forces.

¹⁶² Timothy McCormick, "Shear Walls," (2009).

¹⁶³ Ibid.

PRIVACY

Consider the lens of privacy. There are no specific codes that regulate privacy other than for toilet rooms which restrict a direct view of the interior of a toilet compartment.

However, privacy is still worth considering as it affects one's level of comfort and security in space. According to Francis Ching, "Window and skylight openings provide this view and establish a visual relationship between a room and its surroundings. The size and location of these openings determine, of course, the nature of the outlook as well as the degree of visual privacy for an interior space."¹⁶⁴

Additionally, the "Poetics of Space" by Gaston Bachelard states that the house is a place that shelters day-dreaming and is a place for one to dream in peace. Essentially, a home is the place one is free to be themselves and feel safe. The design of an ADU must create space perceived as private and secure. Privacy considerations include protection for unwanted or public onlookers and the protection against transmission of sound. Simple solutions are appropriate in the creation of privacy. Curtains, blinds, or window arrangements block intrusive views. The use of barriers, increasing distance between sound source and receiving end, and absorptive finishes silence the noise.¹⁶⁵ Something as simple as an operable window can moderate noise and ventilation transmission through the open and close window positions.

COST

Cost is a critical lens to consider on the part of the homeowner. Depending on cost, various aspects of the design may need to be refined or even omitted to meet a project budget. All the materials utilized in construction project have an associated cost. The more custom or unique an element or component or system is, the more likely it will cost more. Additionally, the more area a custom material covers, the higher costs climb. To keep costs low, the homeowner may wish to reduce wall and floor size. Reducing the number of excessive features such as windows, etc., also cuts costs. In the analysis

¹⁶⁴ Ching, *Architecture, Form, Space & Order*.

¹⁶⁵

portion of the decision support system, there is a larger assessment relating cost and design.

LIGHTING

The last lens to consider is lighting. Light assures that all tasks and functions within the dwelling can be performed efficiently and safely at any time throughout the day or night. Lighting is also a safety concern assuring that an occupant is acutely aware of his or her surroundings. As adequate lighting is fundamental to sight, there are rules regarding lighting in the IBC. Some general guidelines of lighting are:

- According to IBC Section 1205.1, “[E]very space intended for human occupancy shall be provided with natural light by means of exterior glazed openings in accordance with Section 1205.2 or shall be provided with artificial daylight in accordance with Section 1205.3.”¹⁶⁶
- Regarding natural light portals, the minimum net glazed area is 8 percent of the floor area of a room.¹⁶⁷
- Regarding artificial light IBC Section 1205.3 states that “Artificial light shall be provided that is adequate to provide an average illumination of 10 foot-candles (107 lux) over the area of the room at a height of 30 inches (762 mm) above the floor level.”¹⁶⁸
- When laying out lights, it is important to consider how an individual can service or replace the light bulb. This precaution is to avoid putting the light fixture in hard to access places.

The seven lenses of view/vista, accessibility/egress, ventilation, structure, privacy, cost, and lighting are important criteria for evaluating an ADU design prototype. These seven lenses do not cover all aspects of design but are general support towards an informed decision regarding a conceptual design at it relates to a building site or the needs of the project. If further information is needed, the homeowner should research the documentation referenced under each category.

¹⁶⁶ Council, *International Building Code.*, 250.

¹⁶⁷ Ibid.

¹⁶⁸ Ibid.

CHAPTER 7 : PRE-DESIGN

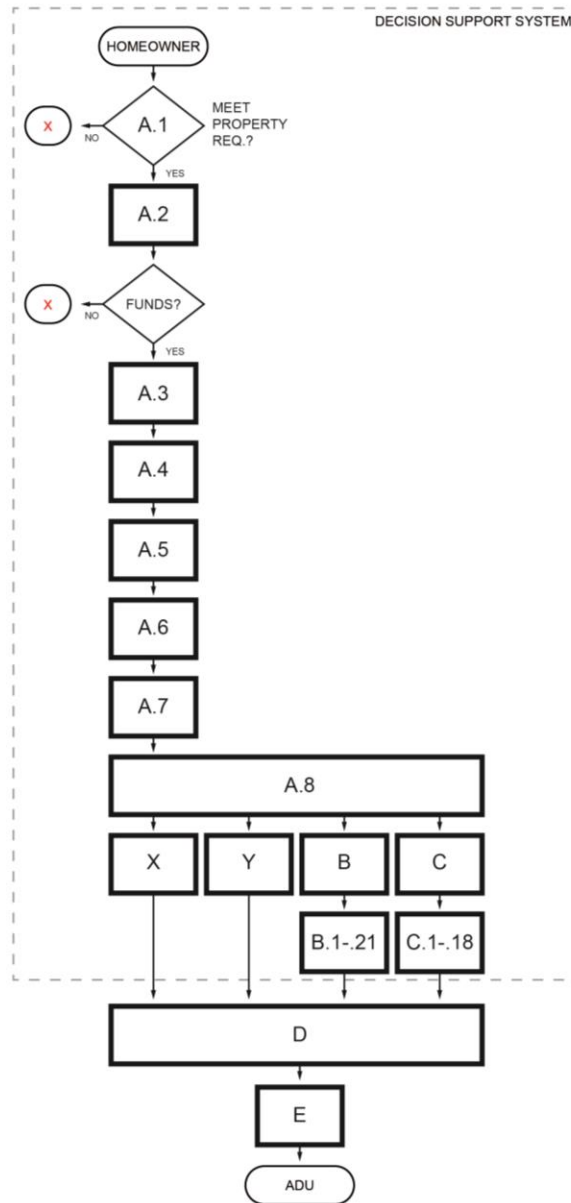

Figure 7.1– A diagram of the overall workflow outlined by the Decision Support System.

Table 7.1 - Reference Steps for Figure 7.1

A.1	Pre-Check
A.2	General Cost Assessment
A.3	List of Desired Space
A.4	Property Identification
A.5	Identify Physical Property Features
A.6	Identify Physical Logistical Features
A.7	Space Analysis
A.8	ADU Type Selection

PRE-CHECK

(Step A.1 refer to Figure 7.1 for complete workflow)

The first step in the decision support workflow is to assess the pre-check conditions. The State of Hawai'i implemented a pre-check form, Figure 3.6, in the ADU permitting process. The form allows the State departments to preliminary check the site for suitability. Homeowners can get property details using the State of Hawai'i website property search tool.¹⁶⁹ Additionally, homeowners should contact these offices directly for information about their property. Filing a pre-check list is encouraged as the approval or disapproval periods by the State departments take a while.

The first thing a homeowner needs to know is what their lot size is. A property must be at minimum 3500 square feet. If the property is 3500 to 4999 square feet, then the property may be eligible for a 400 square foot maximum ADU. If the property is 5000 square feet or more, the property may be eligible for an 800 maximum square foot ADU. If the site is below 3500 square feet, then it will be ineligible to construct an ADU on the property

The next question is whether the property is a flag lot. A flag lot is a parcel of land that lacks sufficient street frontage and must have a private driveway to access the public roadway. If the subject property is a flag lot, it is unlikely an ADU can be built on the site unless other circumstances allow approval. Homeowners should contact the Department of Planning and Permitting (DPP) Traffic Division for specifics.

¹⁶⁹ Honolulu, "Property Search."

Is there an adequate roadway adjacent to the property? The homeowner's property needs to have adequate roadway infrastructure adjacent to the property as well. A road of 18 to 20 foot wide is ideal for approval of an ADU.

A property pursuing an ADU must also be clear of any covenants, conditions, and restrictions (CC&R). Properties located within homeowner associations or are part of any subdivision should carefully investigate any accessory building or structure restrictions. Without fee simple control of the property devoid of covenants, an ADU may not be possible to construct. A homeowner should contact their association if there are any rules and regulations regarding ADUs.

The property must also have a water supply. Usually, water supply has not been a major issue in dealing with ADU permitting. The City and County of Honolulu have yet to deny an ADU project trying connecting to BWS as of March 2017¹⁷⁰. Homeowners should contact the Board of Water Supply (BWS) for further inquiries regarding water supply to their property.

¹⁷⁰ Cruz, "Sewer Hookups Slow Accessory Dwelling Unit Approvals."

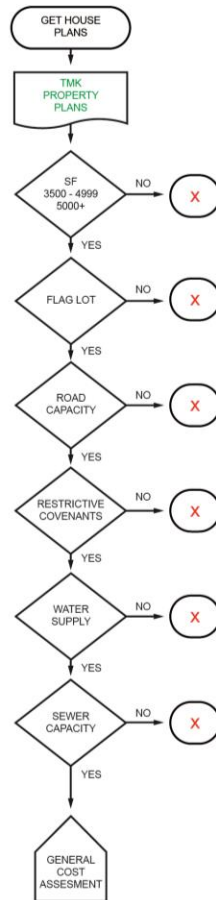

Figure 7.2– A workflow showing the steps to be taken for the pre-check component of the Decision Support System

Lastly, for ADU construction approval, the property must have adequate sewer capacity. The city’s Ohana zone was created with the purpose to map out areas that can potentially accommodate an additional Ohana unit. A property residing in the Ohana zone will likely have sewer capacity or meet the requirements needed for on-site water treatment to add an ADU. Properties outside of the Ohana zone may have sewer capacity for the property. To find out if a property outside the Ohana zone has adequate wastewater infrastructure, the owners should contact the DPP wastewater division for approval.

The importance of the ADU pre-check list is to make sure a property meets the requirements for ADU permitting. If a property does not make it through the pre-check list, the property will not qualify for ADU development. If the homeowner knows the

property will pass the ADU pre-check list, turn it in to start the permitting process because it takes some time. And, the homeowner may now confidently pursue the next steps in the decision support system.

GENERAL COST ASSESSMENT

(Step A.2 refer to Figure 7.1 for complete workflow)

Once homeowners determine if their property qualifies for ADU development, it is time to think about money. The homeowners should determine their budget for the project beforehand. That way they will know if the cost of the ADU is beyond their means. After deciding on the amount they can spend, the owners are ready to estimate their costs for the ADU. This research will use the RSMeans 2010 Square Foot Costs as a reference to establish pricing for the ADU. The RSMeans is a compiler of value data which publishes construct cost books annually for contractors to determine cost estimates.

According to RSMeans the cost rate for a 600 square foot single family home, built using stucco on wood frame construction, cost \$106.90 per square foot in 2010. Using a cost factor provided by RSMeans to adjust prices based on location and a historical index, we can determine present day cost estimates for Hawaii.

$\$106.90/\text{sf}^{171} * 1.21 \text{ (location factor)}^{172} * 1.129 \text{ (historical index factor)}^{173} = \$146.04/\text{sf}$

The above rate \$146 per square foot is simply the base cost estimate and can only indicate conceptual price rather than actual cost. Additionally, use of more costly materials or custom features will increase the cost estimates.

Rather than looking only at RSMeans, it is also important to consider other estimates. Hawaii ADU is marketing their ADU model the Ohana Kit. This product is one of the precedents for this research, and their marketing features a cost estimate ranging from \$150 to \$250 per square foot.¹⁷⁴ Interestingly, the Ohana Kit cost is similar to the RSMeans cost. The Ohana Kit pricing includes shipping, rising construction costs, and

¹⁷¹ "Rsmmeans Square Foot Costs," (Kingston, MA2010).

¹⁷² Ibid.

¹⁷³ RSMeans, "Historical Cost Indexes," (2016).

¹⁷⁴ Home, "Introducing Ohana Kit by Hawaii Adu."

customization costs. Every feature added to the building has associated costs in both materials and labor. At this point, these costs are just estimated to decide if the homeowner can afford to develop an ADU. It is the intent of the Decision Support System to educate homeowners to tailor their design to best suit the needs of the project.

Using the estimate from RSMeans, a low-end 400 square foot ADU would cost about \$58,000 if the rate stays at \$145 per square foot. A high-end ADU will cost significantly more. Using the upper-end rate from HawaiiADU's marketed cost rate, a 400 square foot ADU could cost \$100,000 at a \$250 per square foot rate. The homeowner now has a cost range of \$58,000 to \$100,000 for a 400 square foot ADU. The homeowners must remember these costs shown are not total costs but costs for materials and labor in construction. There may be other associated costs which include permit fees, site grading if necessary, architecture and engineering fees, and other overhead and general fees.

The point of this early general cost assessment is to get a general ballpark figure of what to expect in regards to cost for the development of an ADU. The homeowner should be prepared to spend upwards of \$50,000 for a basic ADU. Any features out of the ordinary may increase the cost of the project. At the end of the design workflow, the cost assessment will be reviewed and refined.

Table 7.2 - Cost breakdown of single family homes based upon national averages.¹⁷⁵

Table 1. Single Family Price and Cost Breakdowns 2015 National Results		
	Average Lot Size:	20.129
	Average Finished Area:	2,802
I. Sale Price Breakdown	Average	Share of Price
A. Finished Lot Cost (including financing cost)	\$85,139	18.2%
B. Total Construction Cost	\$289,415	61.8%
C. Financing Cost	\$6,285	1.3%
D. Overhead and General Expenses	\$26,345	5.6%
E. Marketing Cost	\$3,739	0.8%
F. Sales Commission	\$15,104	3.2%
G. Profit	\$42,292	9.0%
Total Sales Price	\$468,318	100%
II. Construction Cost Breakdown	Average	Share of Construction Cost
I. Site Work (sum of A to E)	\$16,092	5.6%
A. Building Permit Fees	\$3,601	1.2%
B. Impact Fee	\$1,742	0.6%
C. Water & Sewer Fees Inspections	\$4,191	1.4%
D. Architecture, Engineering	\$4,583	1.6%
E. Other	\$1,975	0.7%
II. Foundations (sum of F to G)	\$33,447	11.6%
F. Excavation, Foundation, Concrete, Retaining walls, and Backfill	\$32,576	11.3%
G. Other	\$871	0.3%
III. Framing (sum of H to L)	\$52,027	18.0%
H. Framing (including roof)	\$44,640	15.4%
I. Trusses (if not included above)	\$3,884	1.3%
J. Sheathing (if not included above)	\$1,238	0.4%
K. General Metal, Steel	\$1,272	0.4%
L. Other	\$993	0.3%
IV. Exterior Finishes (sum of M to P)	\$43,447	15.0%
M. Exterior Wall Finish	\$20,717	7.2%
N. Roofing	\$10,069	3.5%
O. Windows and Doors (including garage door)	\$12,127	4.2%
P. Other	\$534	0.2%
V. Major Systems Rough-ins (sum of O to T)	\$37,843	13.1%
O. Plumbing (except fixtures)	\$12,302	4.3%
R. Electrical (except fixtures)	\$12,181	4.2%
S. HVAC	\$12,623	4.4%
T. Other	\$738	0.3%
VI. Interior Finishes (sum of U to AE)	\$85,642	29.6%
U. Insulation	\$6,467	2.2%
V. Drvwall	\$11,744	4.1%
W. Interior Trims, Doors, and Mirrors	\$12,409	4.3%
X. Painting	\$9,002	3.1%
Y. Lighting	\$3,517	1.2%
Z. Cabinets, Countertops	\$16,056	5.5%
AA. Appliances	\$4,463	1.5%
AB. Flooring	\$13,367	4.6%
AC. Plumbing Fixtures	\$4,465	1.5%
AD. Fireplace	\$2,760	1.0%
AE. Other	\$1,393	0.5%
VII. Final Steps (sum of AF to AJ)	\$19,567	6.8%
AF. Landscaping	\$6,156	2.1%
AG. Outdoor Structures (deck, patio, porches)	\$4,349	1.5%
AH. Driveway	\$6,240	2.2%
AI. Clean Up	\$2,054	0.7%
AJ. Other	\$768	0.3%
VIII. Other	\$1,349	0.5%
Total	\$289,415	100%

¹⁷⁵ Carmel Ford, "Cost of Construction a Single-Family Home in 2015," (2015).

LIST OF DESIRED SPACES

(Step A.3 refer to Figure 7.1 for complete workflow)

In this step, the task is to put together a list of desired spaces one wishes to included in the ADU design. Each of the rooms takes up a certain amount of space which relates back to the previous investigation of cost. When determining what types of rooms to include in the design and the allotted space for each room, it is important to understand that there are certain requirements for the minimal number of rooms in a dwelling unit.

First, there are two types of dwelling units. There is a regular dwelling unit and an efficiency dwelling unit. In the regular dwelling unit, the kitchen and the living room are counted separately, whereas in the efficiency dwelling unit the kitchen and living room are combined, and storage is needed. Both the regular and efficiency dwellings require a bathroom. These dwellings also have a slightly different space allotment. In the regular dwelling unit, the living room must be a minimum of 120 square feet, and the kitchen must be a minimum of 50 square feet. In the efficiency dwelling unit, the combined kitchen and living space must be a minimum of 220 square feet. Oddly, however, in the regular dwelling unit, there is no requirement that there needs to be a dividing wall between kitchen and living room.¹⁷⁶

Any additional space added to the ADU that is considered habitable must be a minimum of 70 square feet and cannot be less than seven feet in any direction. The IBC recognizes a habitable space to be “[a] space in a building for living, sleeping, eating or cooking. Bathrooms, toilets rooms, closets, halls, storage or utility spaces and similar areas are not considered habitable.”¹⁷⁷ Below are tables that summarize the minimal requirements for dwelling unit space allocations.

¹⁷⁶ Council, *International Building Code.*, 251.

¹⁷⁷ *Ibid.*, 15.

Table 7.3 - A table for the homeowner to use when establishing the desired spaces within a regular ADU layout

Basic Layout				
Quantity	Quantity Required	Space Name	Minimum Size	Size
	1	Living Room	120 sf.	
	1	Kitchen	50 sf.	
	1	Bathroom	n/a approx. 50 sf.	
	n/a	Bedroom	70 sf.	
	n/a	Storage	n/a	
	n/a	Other	n/a	
Source: Data based on IBC 2006				

Table 7.4 - A table for the homeowner to use when establishing the desired list of spaces within an efficiency ADU layout

Efficiency Layout				
Quantity	Quantity Required	Space Name	Minimum Size	Size
	1	Combined Kitchen and Living	220 sf.	
	n/a	Bathroom	n/a approx. 50 sf.	
	1	Bedroom	70 sf.	
	n/a	Storage	n/a	
Source: Data based on IBC 2006				

PROPERTY IDENTIFICATION

(Step A.4 refer to Figure 7.1 for complete workflow)



Figure 7.3– A map depicting the aerial satellite view and Tax Map Key (TMK) site plan of the example property to be designed. (Left Image Source: Google earth)

Next, the homeowners must examine issues specific to their property. For this step, a scaled drawing or map of the property is necessary. Homeowners can get a copy of the building plan for their property from the DPP. This plan drawing will be to a scale and have a site map with dimensions for use in planning. Using aerial photo imagery taken from Google Earth can also be helpful in assessing the specific conditions of the property. Using digital methods, such as AutoCAD, or traditional hand drawn techniques with trace paper, the homeowners can identify their property's construction obstacles by studying the scaled drawings.

This study uses a generic site to demonstrate the workflow in the Decision Support System. This site may differ from the homeowners' property, but the processes are still the same. The site depicted is a fee simple lot on the west side of the island in a suburban residential area. The property qualifies for the two primary ADU variations explored in this example.

IDENTIFY PHYSICAL PROPERTY FEATURES

(Step A.5 refer to Figure 7.1 for complete workflow)

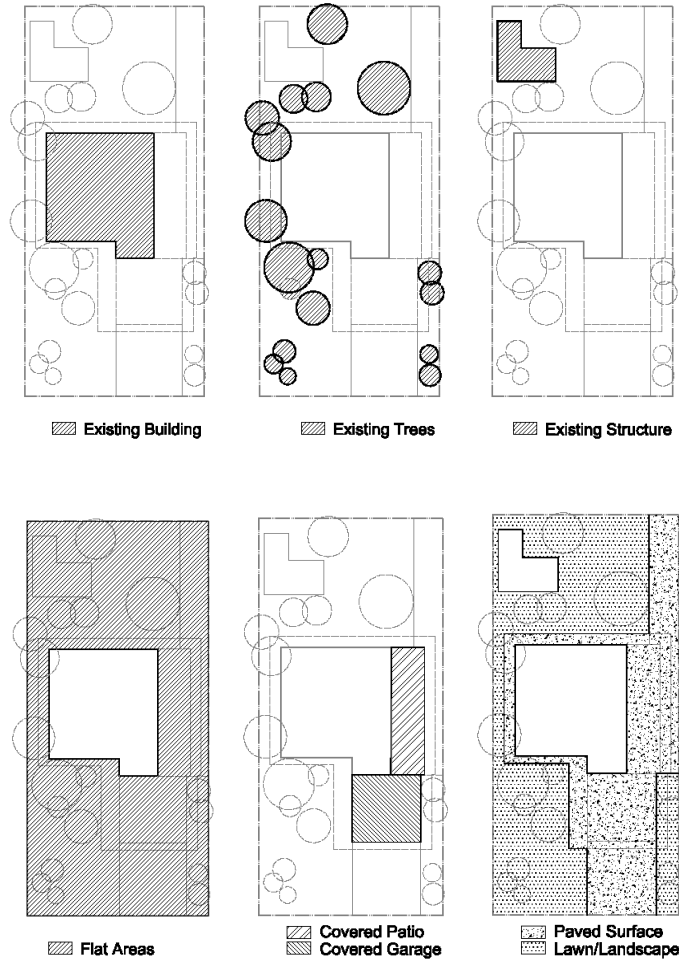

Figure 7.4– A diagram showing the physical features identified in the Decision Support System regarding the example site.

After obtaining the scaled drawings of the property, the homeowners must identify property features and record these abstractly on the property drawing. These abstract sketches should represent the birds-eye view of the feature to best assist in the planning of property layout.

The first features to be recorded are existing buildings. Any buildings should already be drawn to scale on the site plan from DPP. The building's illustration has accurate

dimensions, placing and positioning of the building in its location about the property and its boundaries.

The next set of features to identify are any existing trees on the site. The location of specific trees can be assessed through a survey of the existing property or by cross-referencing satellite pictures on Google Earth, or any other up to date satellite picture, and then referencing the location of the trees about the scaled house drawings. The United States Geological Survey (USGS) has a high-resolution interactive map from which an individual can get updated satellite imagery.¹⁷⁸ The location and approximate tree canopy size should be documented so proposed ADU designs do not get too close to existing features. It is important to note trees have root systems that spread out horizontally depending on the species. Structures that get too close to this root system may run into problems where the roots begin to damage the new construction. The example site has a variety of trees with large canopies.

Any accessory or structures, permitted or not, should also be documented on the drawings for planning purposes. These structures may need to be relocated or removed to avoid conflict with the new proposed ADU. The example site has one additional structure to note.

A complex aspect of assessing a property is finding a record of the site's topography. The new ADU will need placement in an area that is relatively flat. The homeowner can either place the ADU in a flat location or grade the site to make a flat location. The latter option costs more. Homeowners can professionally survey the property to get the grading of the site documented if precise consideration is necessary. For a conceptual understanding of the topography, the homeowners can use the Honolulu Land Information System which is an online mapping tool that displays up to 5 feet differences in elevation. The example site is relatively flat, so topography is not a concern.

Next, the owners should document any covered exterior areas such as garages or covered patios. This step is important to assess if there is a potential to reuse the

¹⁷⁸ United States Geological Survey, "Earth Explorer," <https://earthexplorer.usgs.gov/>.

covered area as an ADU. Covered areas are important for identification when pursuing the “Attached Modified ADU.”

The last set of features to assess are the currently paved and landscaped areas. Paved areas are of interest because they require demolition if conflicting with the new ADU design. A cost-effective design may be to avoid placing the ADU over a paved surface. Another strategic approach would include placing the ADU directly adjacent to the paved area so that the paved area acts as an access path to the ADU.

Once all the features appear in the scaled drawing, the designer will have the information to determine the layout and placement of elements about the existing physical features of the site. Recording the features of the property can aid the homeowner in planning the cost of constructing the ADU. It helps to know ahead of time if any features need to be removed or altered for development. Since these types of alterations are usually costly, the homeowners need to figure these costs into the ADU budget.

IDENTIFY LOGICSTICAL PROPERTY FEATURES

(Step A.6 refer to Figure 7.1 for complete workflow)

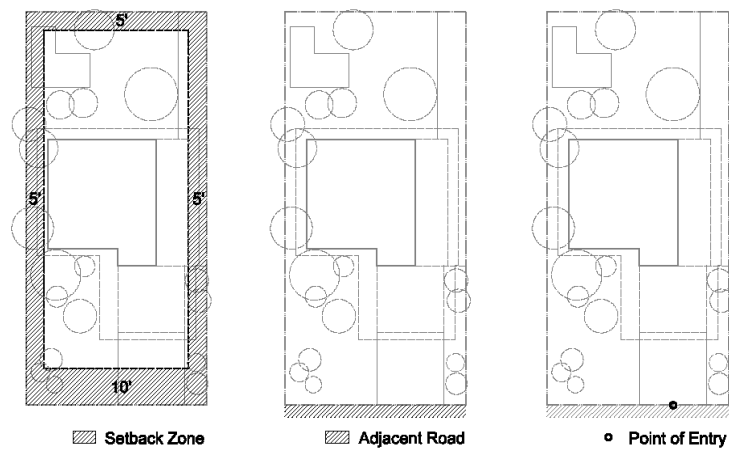

Figure 7.5- A diagram showing the logistical features identified in the Decision Support System regarding the example site.

The logistical features of the site also play a role in the planning of the ADU. The logistical features include setbacks, building envelopes, adjacent public right-of-way, and entry to the site. Additional logistical features that are noteworthy of including but not a feature of the example site are easements on the property.

The first of the logistical features to consider is the property setbacks. The owner can use the DPP property search tool to look up information about the specific site. Typically for residential developments, the setbacks for the site are as depicted on the Land Use Ordinance residential development standards. To the front of the lot, there is a ten-foot setback from the property line. To the sides and rear of the property, there is a five-foot setback.¹⁷⁹ No built structure is allowed to be built within the setback zone around the site.

The adjacent public right-of-way is important to identify and document as it will serve as the roadway access from which to service the ADU. The new parking (if included) should be placed near the public right of way for convenience. The right-of-way is also important in that it is the direction from which people in the public view the property. For an aesthetic consideration, a homeowner may wish to have the display facing the street to be somewhat attractive.

The last logistical feature to consider is similar to the public right-of-way. The feature is the point of access to the site. Understanding where an individual approaches the site and gains access to the site is important to consider when planning out how one is to navigate and gain entry to the ADU.

¹⁷⁹ Honolulu, "Chapter 21: Land Use Ordinance."

SPACE ANALYSIS

(Step A.7 refer to Figure 7.1 for complete workflow)

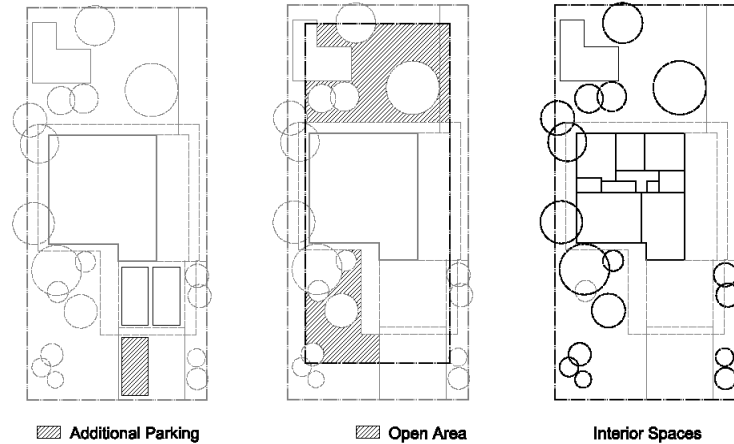

Figure 7.6- A diagram showing the spatial features identified in the Decision Support System regarding the example site.

The logistical features of the site also play a role in the planning for the ADU. The logistical features include setbacks, building envelopes, adjacent public right-of-way, and entry to the site. Additional logistical features to note are any easements on the property. Easements are a right granted to someone to across an owner's property. For example, a utility company that has an easement across a homeowner's property to access underground cables.

The first of the logistical features to consider is the property setbacks. The owners can use the DPP property search tool to look up information about their property. Typically for residential developments, the setbacks for the site are as depicted in the Land Use Ordinance residential development standards. To the front of the lot, there is a ten-foot setback from the property line. To the sides and rear of the property, there is a five-foot setback. The homeowner cannot build any structure within the setback zone around the site.

The adjacent public right-of-way is important to identify and document as it will serve as the roadway access for the ADU. The new parking (if included) should locate near the public right of way for convenience. The right-of-way is also important because it is the

direction from which people in the public view the property. For aesthetic reasons, the homeowners should consider the curb side appeal of their property. Curbside appeal is important because it affects the property value of not only the owners' property value but also the property value of those them.

The last logistical feature to consider is an entry to the property. Like public right-of-way, the point of access to the site is important because this is the direction from which people approach the property and gains access to the property. It is important to plan how people will gain entry to the ADU.

ADU TYPE SELECTION

(Step A.8 refer to Figure 7.1 for complete workflow)

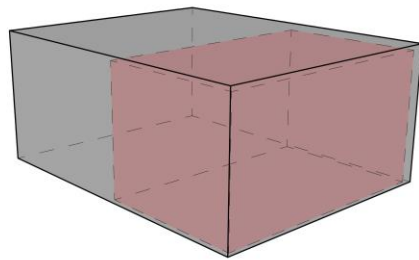

Interior ADU

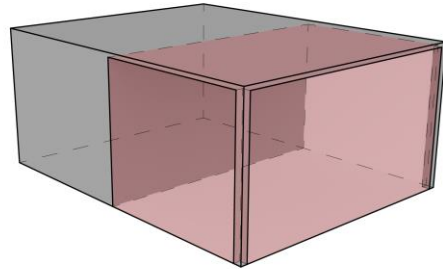

Attached Modified ADU

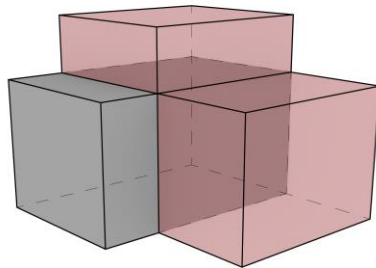

Attached New ADU

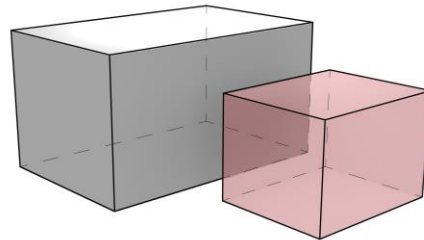

Detached ADU

Figure 7.7– Diagram depicting the various ADU types used in the Decision Support System.

The final stage of the pre-design component to the Decision Support System is the ADU Type Selection. Action Construction, a California-based construction company that deals with ADUs, identifies three types of ADU which include the “Interior ADU,” the “Attached ADU,” and the “Detached ADU.”¹⁸⁰ This research has determined that there are four primary types of ADU. The additional two ADU types are a breakdown of the attached

¹⁸⁰ Action Construction, "Types of Accessory Dwelling Units," <http://www.actonconstruction.com/types-of-adus>.

type of ADU and are the “Attached Modified ADU” and the “Attached New ADU.” These two are fundamentally different.

The “Interior ADU” is a room or floor conversion. “Located in the primary dwelling, an interior ADU is built from existing converted space, usually an attic or basement.”¹⁸¹ This type of ADU is the simplest of the four types because vacant space already exists in the primary dwelling. There may be additional partition walls added or new plumbing fixtures added, but through a series of modifications to the existing home, the conversion is less complicated than the remaining three categories of ADUs. Additionally, little to no new construction is performed in this type making this ADU the most cost-effective of the four. Because the homeowners do not need to construct an additional structure to their property, a design approach for this type of ADU is unnecessary. The homeowner is advised to contact the necessary contractors or licensed professionals to pursue the conversion.

The second type is the “Attached Modified ADU.” This ADU utilizes a covered structure that is pre-existing and is attached to the primary residence. The ADU needs new services and utilities that require a careful examination of the proposed ADU and how the design affects the primary residence. Like the “Interior ADU,” the “Attached Modified ADU” makes use of an existing built space. The difference is this type utilizes an external location and turns it into an interior space.

The third type is the “Attached New ADU.” The fundamental difference between this type and the “Attached Modified ADU” is that the “Attached New ADU” does not repurpose an existing built structure but constructs an entirely new structure that shares one surface with the existing structure. This type of ADU does not make use of an existing foundation slab or covered roof structure. Within the “Attached New ADU” there are two subgroups of this type the “Attached New ADU – Horizontal” and the “Attached New ADU – Vertical.”

The “Attached New ADU—Horizontal” subgroup is most like the “Detached ADU.” The horizontal subgroup is a new construction adjoining the existing structure on one side. The subtle difference between the “Detached ADU” and the “Attached New ADU –

¹⁸¹ Ibid.

Horizontal” is the need to address spaces in the existing home. The owners can obtain the procedures to do so from the “Attached Modified ADU” workflow outline. Thus the Decision Support System will not include a step-by-step workflow for the “Attached New ADU – Horizontal.” The homeowner can use the hybrid workflow of these two types that will be outlined.

The “Attached New ADU-Vertical” subgroup is very different from all the other types. This type involves the addition of a new second story on top of an existing single family home. The reason this subgroup is so different is that it is not only a fully new construction but it also significantly modifies the pre-existing building. The roof and foundations of the existing home need to be reevaluated to support and include the new ADU. The complexity of the “Attached New ADU-vertical” requires precise structural consideration as well as the considerations for vertical accessibility/egress. Because the Decision Support System hopes to optimize a workflow that is straightforward so a homeowner can generate a simple, organized plan to create an ADU, the “Attached New ADU – Vertical” development is too complex due to very specific procedures that need consideration. Currently, the Decision Support System does not encompass the design considerations for the “Attached New ADU – Vertical.” Rather it recommends a homeowner seeking this variant of ADU seek professional assistance from the start or consider the use of the other simpler types instead.

The last type of ADU is the “Detached ADU.” This type is simply “[a] stand-alone structure separate from the primary dwelling. A detached ADU can be built as entirely separate unit...”¹⁸² Action Construction also considers the modification of an existing detached carport or patio as a variation of the “Detached ADU.” The Decision Support System considers the repurposing of an unattached carport or patio the modification of an existing structure, even though not connected to the primary dwelling. Therefore, the Decision Support System considers this modification in the “Attached Modified ADU” workflow. The “Detached ADU” is the second simplest ADU to construct in comparison to the “Interior ADU” as the designer can start fresh without needing to consider how the design modifies the existing structure.

¹⁸² Ibid.

The Decision Support System will elaborate on the “Attached Modified ADU” and the “Detached ADU” as they provide diverse considerations that apply to the remaining types. The next step is figuring out which ADU type best fits the situation of the homeowner. Following the type selection workflow will allow the homeowners to determine for themselves which is their best option.

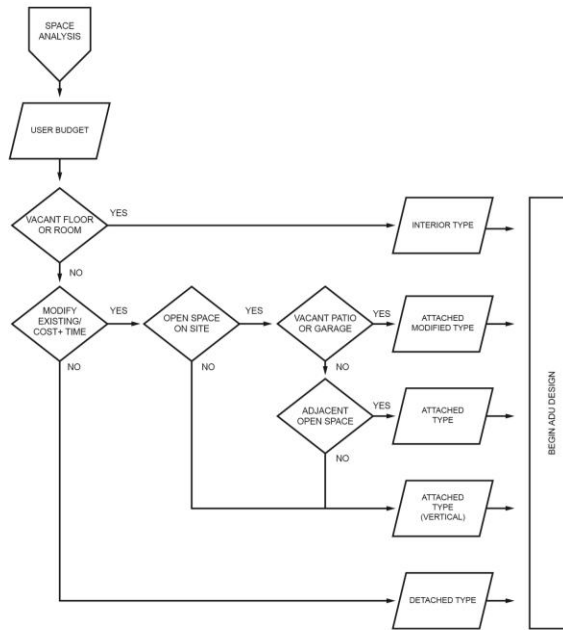

Figure 7.8– Diagram depicting the ADU type selection process.

The first step in the type selection workflow is to determine an acceptable budget for the homeowner. Based upon the general cost assessment the homeowner will determine an amount that seems reasonable to fund this development project. The site will ultimately dictate what the possible types of ADU the owners can construct. Depending on the budget provided, a homeowner may be limited in his or her capacity to implement the applicable ADU strategy. It is important to compare the homeowners personal budget and the ADU budget to determine if building an ADU is in the owners’ best interest and whether the project is possible or not.

If there is a reasonable budget for the project, the homeowners can ask the first question. Is there a pre-existing vacant room or floor that is at least 220 square feet, the minimum possible amount of space for a dwelling unit. If the answer is, “yes,” then an

“Interior ADU” is a possible option. An owner may not wish to pursue an ADU within their home, but it is an option to consider.

If the answer to the first question was, “no,” or the homeowners do not wish to pursue the interior type, then the next question can be asked. Is the owner okay with modifying the existing building and having to vacate the premises during the construction period potentially? The modification of existing walls, roofs, and slab structure could potentially compromise the integrity of the existing structure during the construction period. And, construction takes a considerable amount of time. If the homeowner is willing to vacate the property during construction, the range of attached ADU types are candidates for consideration. If the owner is unwilling to vacate the property, the “Detached ADU” is the only option provided there is a potential open space on the site. Otherwise, an ADU may not be possible.

In the pursuit of the attached ADU types, the next question addresses the amount of open space next to the existing building. The “open space” also includes covered spaces like open patios and carports. If the answer is unfavorable, the only option is the “Attached New ADU – Vertical.” If the answer is favorable, then the other attached types are possible considerations.

To answer the next question, the homeowner needs to decide if there is a vacant carport or patio. If there is a vacant carport or patio to use, then the “Attached Modified ADU” is a viable option. If there is no vacant garage or patio, there is one more question to consider.

The last question in the ADU type selection workflow is, does adequate open space adjacent to the existing building exist. If it does, then the “Attached New ADU – Horizontal” is an option to consider. If adjacent open space does not exist and the owner responded positively to adequate open space on the property, the homeowner can pursue the “Detached ADU.” If open space is not available, the homeowner may have to rethink the ADU possibility.

Once an ADU type that fits the site as well as the needs and desires of the homeowners, they can begin the design process for the ADU. For reasons explained earlier, the

Decision Support System workflow will elaborate on the “Detached ADU” and the “Attached Modified ADU.” For “Attached New ADU – Horizontal,” refer to both workflows and combine features as they apply. For “Interior ADU,” minimal design is needed, and it is recommended to start by engaging a professional to begin the design modification and permitting process. For the “Attached New ADU – Vertical” it is recommended that the owner seeks a design professional from the start who will carefully assess the design.

Next, the Decision Support System will outline steps to generate a conceptual design for an ADU. Each step will assess choices based upon the seven-lens design framework. Though every lens will not apply to each step, the homeowner or designer should consider and assess the steps according to the lenses to see if they apply.

CHAPTER 8 : DESIGN WORKFLOW FOR A DETACHED ADU

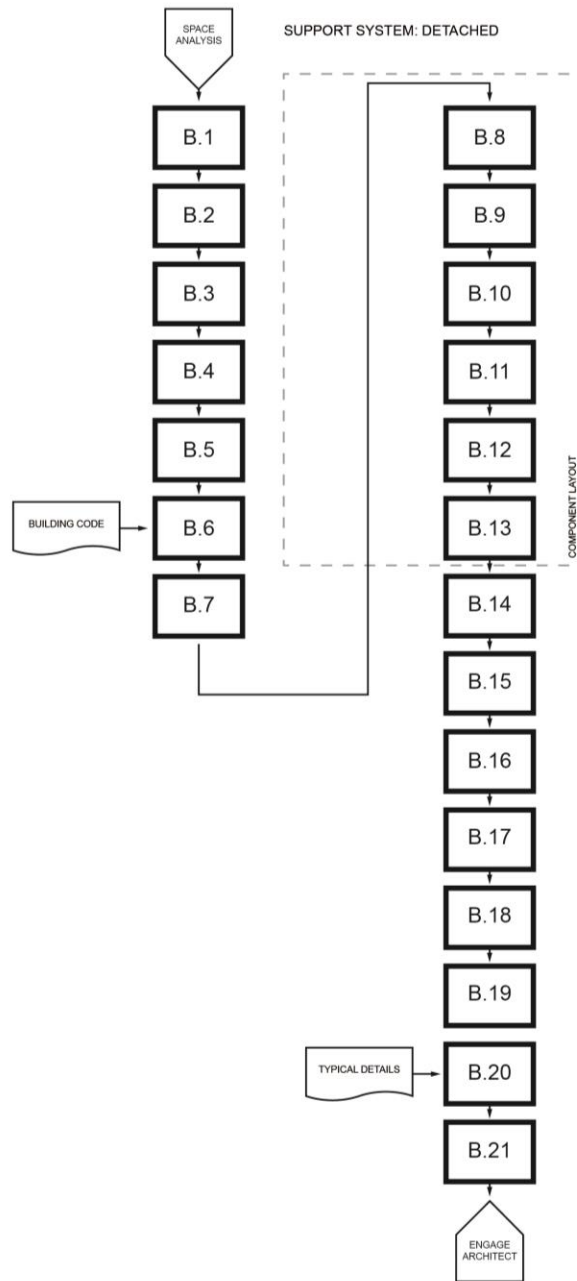

Figure 8.1– Workflow diagram showing the design procedures for a Detached ADU.

Table 8.1– Reference Steps for Figure 8.1

B.1	ADU Placement
B.1	Existing Feature Conflict Planning
B.3	Placement Refinement
B.4	Building Orientation Planning
B.5	Internal Division Analysis
B.6	Internal Layout Planning
B.7	Internal Layout Refinement
B.8	Identify Necessary Components
B.9	Kitchen Component Layout
B.10	Bathroom Component Layout
B.11	Bedroom Component Layout
B.12	Living Room Component Layout
B.13	Door and Circulation Planning
B.14	Layout Refinement
B.15	Window Planning
B.16	Roof Span Analysis
B.17	Building Section
B.18	Roof Pitch Determination
B.19	Section Refinement
B.20	Construction Systems Application
B.21	Conceptual Material Takeoff

ADU PLACEMENT

(Step B.1 refer to Figure 7.1 and Figure 8.1 for complete workflow)

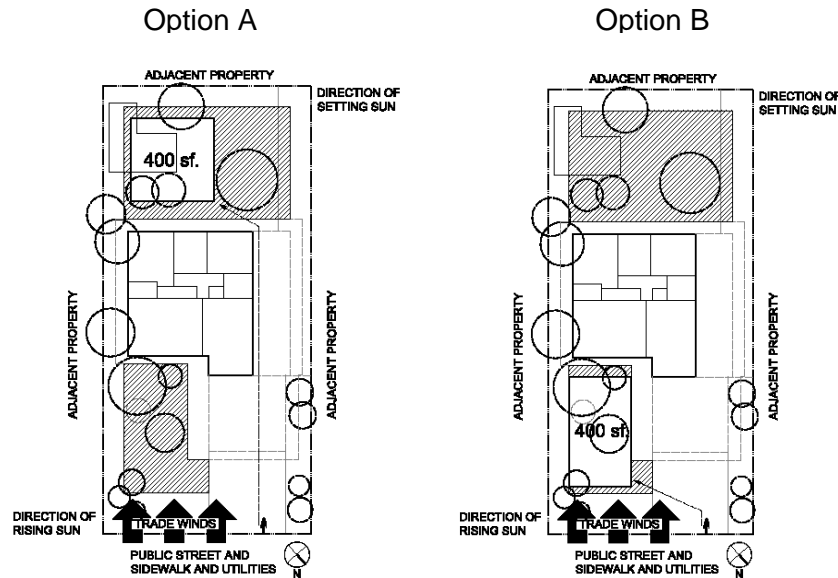

Figure 8.2– General placement assessment for a Detached ADU on the example site.

The first step in designing the “Detached ADU” is determining the ideal placement location for the structure within the property boundaries. The homeowners create a 400 square foot square to the same scale as the scaled property drawing used to document the existing site conditions and features. If the property is 5000 square foot or more, the homeowners can use an 800 square foot square instead of the 400 square foot square. The homeowners assess various placement options on the site in areas that are potential open spaces. Potentially open areas do not consider physical features other than the existing building. The homeowners can remove all other physical features if desired. Remember, removing features adds to construction costs. Once a variety of optional placement locations are chosen, the homeowner evaluates each option through the seven design lenses.

On the example property, two potentially open placement options exist. Option A places the ADU in the rear of the site. Option B places the ADU in the front of the site. The owners must evaluate both options through the seven design lenses.

View/Vista

Option A: This option maintains a clear view of the front yard. Pedestrians from the

street see the existing house and an open front yard. Occupants of the house look out onto the street. (+1)

Option B: This option blocks the views in the front yard. Pedestrians from the street see the ADU structure obstructing the view of the main house. The front yard no longer exists. The ADU also blocks the view onto the street of the occupants in the house. (-1)

Accessibility/Egress

Option A: Though far from the street, the ADU at the rear of the property maintains a clear path of egress to and from the location and the public right-of-way. (+1)

Option B: The ADU in the front of the property has a clear path of egress to and from the location and the public right-of-way. (+1)

Ventilation

Option A: The ADU to the rear of the property is not ideal to wind access. The primary residence blocks most of the Tradewinds that approach the site. (-1)

Option B: The ADU to the front of the property is also not ideal in a similar respect. The ADU blocks wind access to the primary dwelling. (-1)

Structure

Option A: The placement of the ADU structure benefits from a flat location. The location to the rear of the property is flat and ideal for construction. (+1)

Option B: The location at the front of the property is also flat and ideal for construction. (+1)

Privacy

Option A: With the ADU in the rear of the property, the occupants of both the ADU and the existing home have no privacy concerns. (+1)

Option B: With the ADU in the front of the property, the ADU are close to the public right-of-way. This placement creates an unwanted clear line of sight into the dwelling. Furthermore, a shortened distance to the street allows for the undesired transmission of transmits noise between public pedestrians and dwelling occupants. (-1)

Cost

Option A: If the location of utility connections is in the public right-of-way, option A is

furthest from the street. That utility connection needs to extend to meet up with the ADU at the rear of the property. The extensions would require additional piping and wiring. The extension would increase costs. (-1)

Option B: If the location of utility connections is in the public right-of-way, option B is the closest to the street. This position is the more advantageous. Because little to no extensions is needed, this position reduces costs. (+1)

Lighting

Option A: The ADU will receive adequate daylight as a supplement to artificial lighting indoors. Lighting will be abundant in the afternoon and evening. Also, the ADU will block the low sun from the primary residence. (+1)

Option B: With the ADU in the front of the property, the unit receives the morning sun and adequate light throughout the day. The ADU will, however, block the morning sun from getting into the primary residence. (-1)

Total Scores

Option A: +3 (selected)

Option B: -1

EXISTING FEATURE CONFLICT PLANNING

(Step B.2 refer to Figure 7.1 and Figure 8.1 for complete workflow)

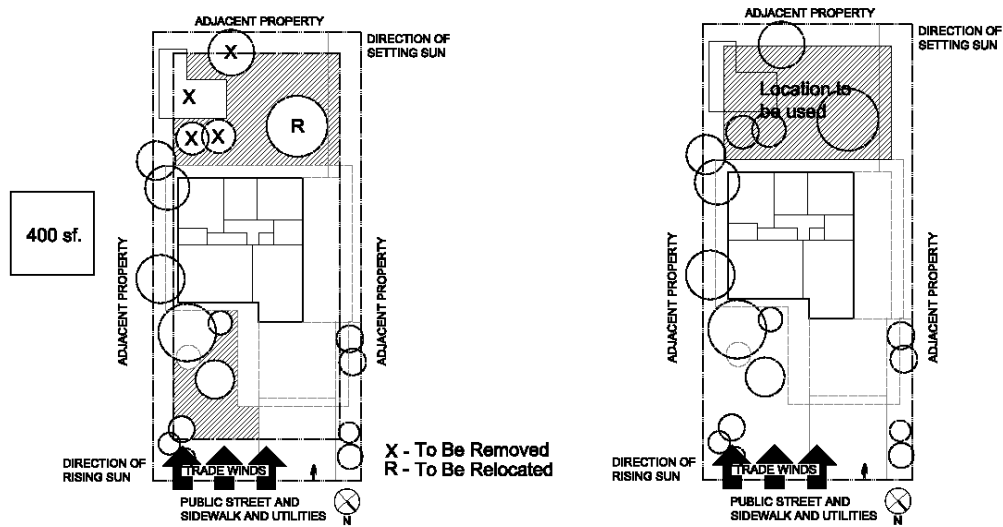

Figure 8.3— Assessment of existing features on site determine potential physical conflicts with Detached ADU on the example site.

Based on the proposed location selected, the homeowners need a strategy regarding physical feature conflicts. The owners can remove the physical features that are in the way of constructing the ADU or relocate them to another location. In the example, the proposed location has five conflicting items, four trees, and one built structure. How the owners deal with the physical features is a personal decision. In the example, the homeowners decided to relocate one tree and remove the remaining physical feature conflicts.

PLACEMENT REFINEMENT

(Step B.3 refer to Figure 7.1 and Figure 8.1 for complete workflow)

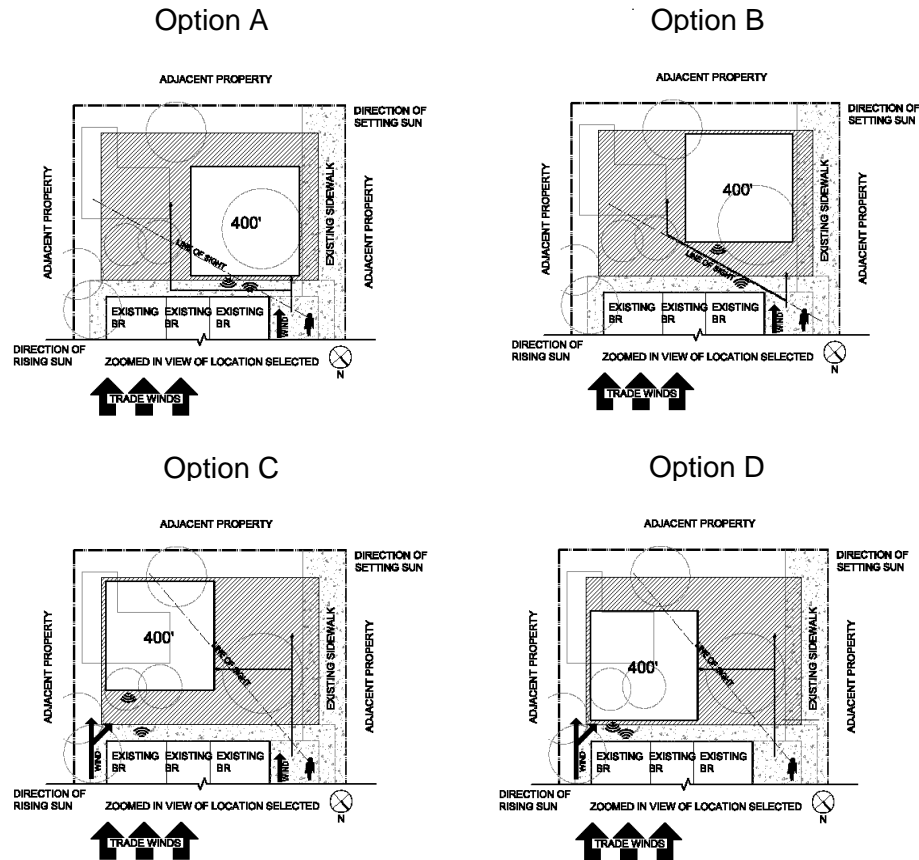

Figure 8.4– Refined specific placement of the Detached ADU within the larger placement area on the example site.

In the placement refinement step, the homeowner decides the exact placement for the ADU within the ideal placement location. The owners determine a range of placement options and assess the positives and negatives of each position.

View/Vista

Option A: The view of the ADU confronts a person walking into the backyard and blocks the view of the remainder of the yard. (-1)

Option B: Like option A, the view of the ADU confronts a person walking into the backyard and blocks the view of the remainder of the yard. (-1)

Option C: A person walking into the backyard sees a view of an open area. But, as the person gets farther into the back yard, he or she see the ADU. (+1)

Option D: A person walking into the back yard has an open view of the yard. The person may be unaware of the ADU until turning the corner. (-1)

Ventilation

Option A: The ADU is cut off from the tradewinds. (-1)

Option B: Having the ADU pushed back to the rear of the property allows the wind to flow along two sides of the ADU. (+1)

Option C: Like option B, having the ADU pushed back to the rear of the property, allows the ADU to get more ventilation across the front surface. (+1)

Option D: The ADU is cut off from the tradewinds. (-1)

Privacy

Option A: The ADU is too close to the existing building. Issues arise of noise transmission and line of site from one dwelling into another. (-1)

Option B: Having ADU pushed back to the rear of the property allows for adequate buffer distance between both dwellings to improve privacy. (+1)

Option C: This option also features sufficient buffer distance between the two dwellings to improve privacy. (+1)

Option D: There is not enough distance between the two dwelling units. (-1)

Total Scores

Option A: -3

Option B: +2

Option C: +3

Option D: -3 (selected)

BUILDING ORIENTATION PLANNING

(Step B.4 refer to Figure 7.1 and Figure 8.1 for complete workflow)

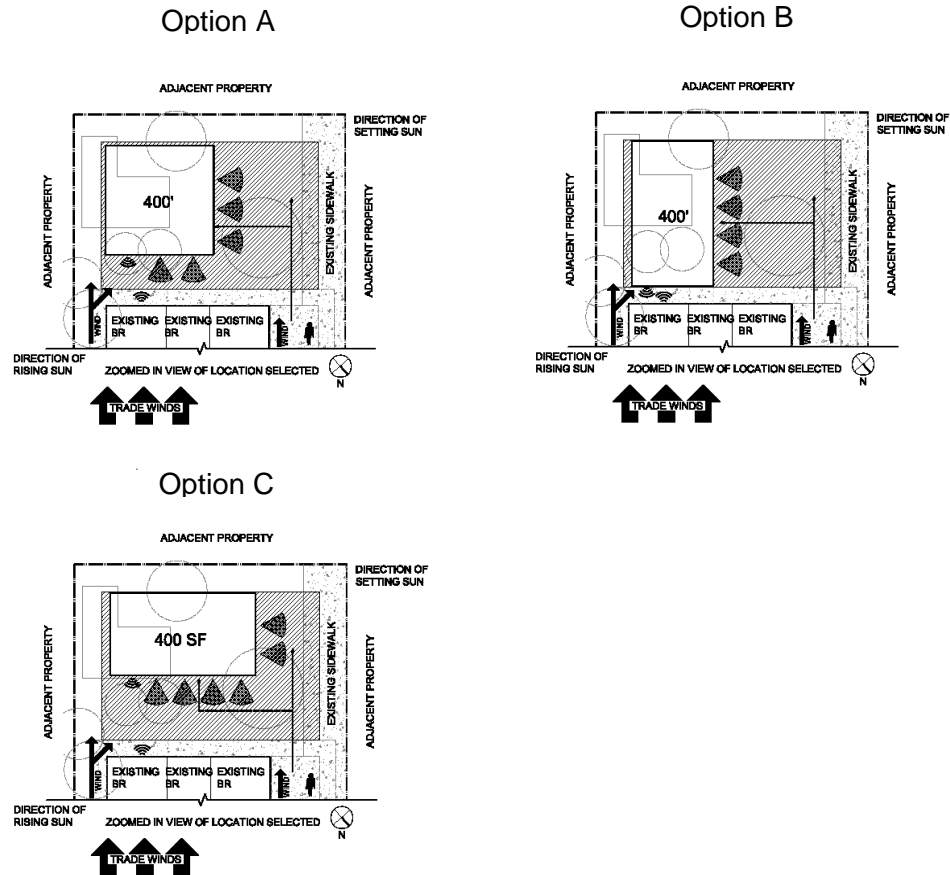

Figure 8.5– Orientation and shape options for example Detached ADU.

After deciding the exact placement of the ADU, the homeowner needs to determine the orientation and basic proportions of the ADU. The homeowners test variations of orientation to evaluate their benefits and drawbacks.

View/Vista

Option A: In the square configuration, the orientation of the ADU favors no direction. This configuration features slight views to both the northeast and northwest. (+1)

Option B: The vertical configuration favors a view toward a large open space in the northwest direction. (+1)

Option C: The horizontal configuration positions the occupant of the ADU and a person walking into the back yard towards a large open space between the ADU and the existing building. (+1)

Ventilation

Option A: This configuration is bi-directional and allows for a slight amount of wind to flow along the northeast and southeast sides of the ADU unit. (+1)

Option B: Positioning of the ADU close to the existing house cuts off ventilation coming from the east side and creates a poorly ventilated open space to the northwest of the ADU. (-1)

Option C: The wind flows along the broad side of the ADU and ventilates two sides. (+1)

Structure

Option A: The bi-directional orientation creates a medium sized roof span that is equal in both directions. (-1)

Option B: The linear orientation creates a possibility for a small short spanning roof in the southeast – northwest alignment. (+1)

Option C: Like option B, the orientation creates a possibility of a small short spanning roof in the southwest – northeast alignment. (+1)

Privacy

Option A: The square configuration provides sufficient distance from the primary dwelling to allow for privacy. (+1)

Option B: The vertical scheme is too close to the existing building. Issues of noise transmission and line of sight between dwellings may arise. (-1)

Option C: The horizontal scheme provides sufficient distance between the two buildings to allow for privacy. (+1)

Total Scores

Option A: +1

Option B: -1

Option C: +3 (selected)

INTERNAL DIVISION ANALYSIS

(Step B.5 refer to Figure 7.1 and Figure 8.1 for complete workflow)

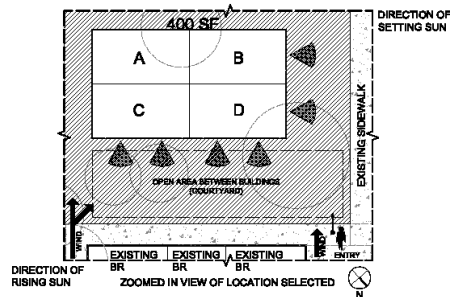

Figure 8.6– Equal division of the example Detached ADU area to assess the opportunities and drawbacks of each internal location.

After determining the orientation and rough shape and size of the proposed ADU design, the next step is determining the potential design of internal spaces. The homeowner divides the area into four equal parts. The homeowner can, later, subdivide the quadrant areas if more spaces are desired. Divisions should be kept orthogonal, or to have right angles, to reduce the complexity of the design. Give each division a non-descript label representing a quadrant within the ADU. In the example, the area divides into four quadrants, A, B, C, and D. The homeowner needs to analyze the four quadrants through the seven design lenses.

View/Vista

Quadrant A: This quadrant has a poor view and can only see the walls bordering the property boundary.

Quadrant B: This quadrant looks out to open space on the side of the ADU

Quadrant C: This quadrant looks out to the open space between the two dwellings. This open area has the potential to serve as a courtyard.

Quadrant D: This quadrant looks out to the open space on the side of the ADU and the open space between the two dwellings. With a view of both open spaces, this location has the most prized view.

Accessibility/Egress

Quadrant A: This quadrant is the furthest from the point of entry.

Quadrant B: This quadrant has a mild travel distance from the point of entry.

Quadrant C: This quadrant has a mild travel distance from the point of entry.

Quadrant D: This quadrant is the closest to the point of entry.

Ventilation

Quadrant A: This quadrant has moderate ventilation as the wind flows across primarily one surface.

Quadrant B: This quadrant has moderate ventilation as the wind flows across primarily one surface.

Quadrant C: This quadrant has an ideal wind access with two surfaces exposed to the trade winds.

Quadrant D: This quadrant has an ideal wind access with two surfaces exposed to the trade winds.

Privacy

Quadrant A: This quadrant is the most private. Quadrant A is the furthest from the point of entry to the property. Another room and an adjacent wall buffer quadrant A.

Quadrant B: This quadrant is distant from the point of entry to the property but exposed on one side. Quadrant B can serve semi-private functions.

Quadrant C: Like quadrant B, this quadrant is distant from the point of entry to the property but exposed on one side. Quadrant C can serve semi-private functions.

Quadrant D: This quadrant is the closest to the point of entry to the property and exposed on two sides. Quadrant D should serve the most public functions.

Lighting

Quadrant A: Receives no direct sun

Quadrant B: Receives evening sun

Quadrant C: Receives morning sun

Quadrant D: Receives no direct sun

Having analyzed the qualities of the ADU, the homeowners can decide what quadrants household rooms should be placed based on the rooms functional needs. Listed below

are the household rooms, their required square footage, privacy needs, and their ideal quadrants.

Living Room

Required size: 120 square feet minimum¹⁸³

Privacy needs: Public functionality

Ideal location: Location D

Bedroom

Required size: 70 square feet minimum¹⁸⁴

Privacy needs: Semi-Private functionality

Ideal location: Location B, Location C

Kitchen

Required size: 50 square feet minimum¹⁸⁵

Privacy needs: Semi-Private functionality

Ideal location: Location B, Location C

Restroom

Required size: N/A

Privacy needs: Private functionality

Ideal location: Location A

¹⁸³ Council, *International Building Code.*, 251.

¹⁸⁴ *Ibid.*, 251.

¹⁸⁵ *Ibid.*, 251.

INTERNAL LAYOUT PLANNING

(Step B.6 refer to Figure 7.1 and Figure 8.1 for complete workflow)

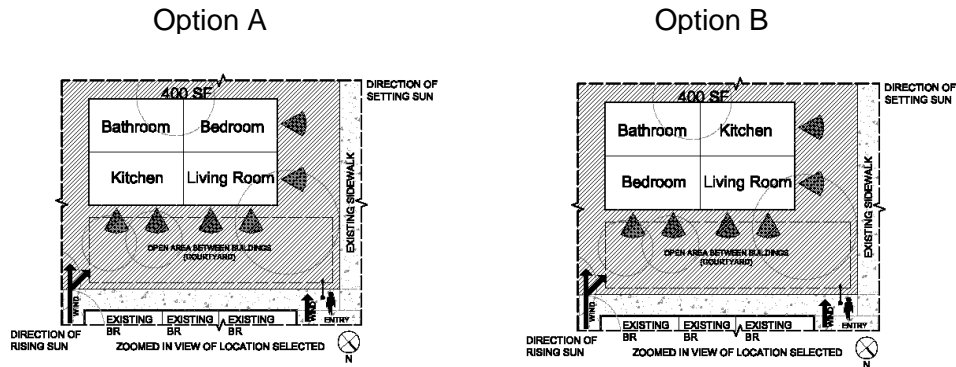

Figure 8.7– Two internal space use alternatives for the example Detached ADU.

Following the analysis of ideal quadratic locations, the homeowners must decide the possible layout schemes that will create an ideal layout plan. In the example property, the homeowners have decided the quadrants of the living room and bathroom, but have yet to decide on the quadrants for the kitchen and bedroom. Below is the homeowners' analysis of the two proposed layout schemes.

View/Vista

Option A: The kitchen has the desirable “courtyard view.” The homeowners envision sitting in the kitchen and watching the outside courtyard. But, is this the room that needs the better view? (-1)

Option B: The bedroom has the desirable “courtyard view.” The bedroom seems more appropriate to have the nice view as during the daytime someone may want to use part of it as a secondary office. (+1)

Ventilation

Option A: The bedroom has low ventilation. The occupant of the ADU might like ventilation while sleeping. (-1)

Option B: The bedroom has sufficient ventilation with wind flowing over two surfaces. (+1)

Lighting

Option A: Kitchen gets morning sun. (+1)

Option B: Bedroom gets morning sun. (+1)

Total Scores

Option A: -1

Option B: +3 (selected)

INTERNAL LAYOUT REFINEMENT

(Step B.7 refer to Figure 7.1 and Figure 8.1 for complete workflow)

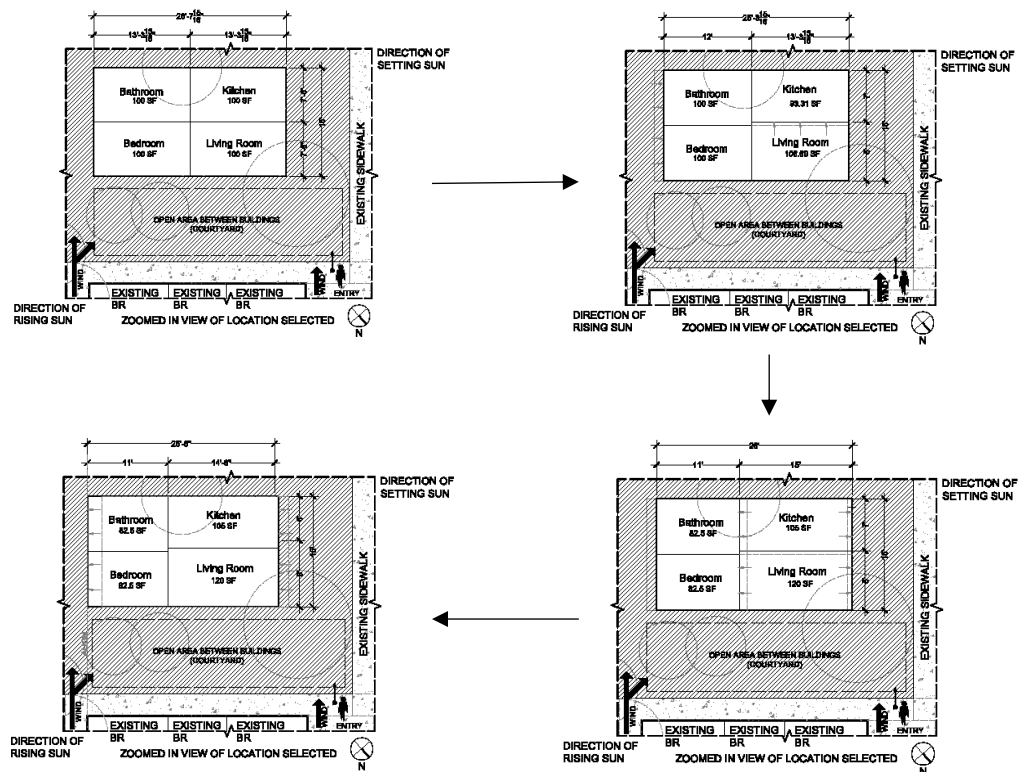

Figure 8.8– Progression of refinement modifications for the example Detached ADU.

The next step is to refine the allocation of space within the layout plan previously. Different household rooms have certain square footage requirements according to the IBC. The designer must revise the divisions of space because in the current layout all the rooms have equal amounts of area.

Space Requirements for Rooms

Living room – 120 square feet minimum (increase allotment)

Bedroom – 70 square feet minimum (decreases allotment)

Kitchen – 50 square feet minimum (decrease allotment)

Restroom – N/A (decrease allotment)

Additionally, in this refinement stage, it may be beneficial to further adjust spaces by evaluating through the seven design lenses.

View/Vista: In this step, the ADU and existing building were aligned along the southeastern edge to create a stronger visual relationship between the two structures.

Accessibility/Egress: Room sizes were adjusted to meet required room allotments.

Cost: Extra floor area on the southeastern side of the ADU was removed to reduce the square footage of total structure and slightly reduce costs in construction.

IDENTIFY NECESSARY COMPONENTS

(Step B.8 refer to Figure 7.1 and Figure 8.1 for complete workflow)

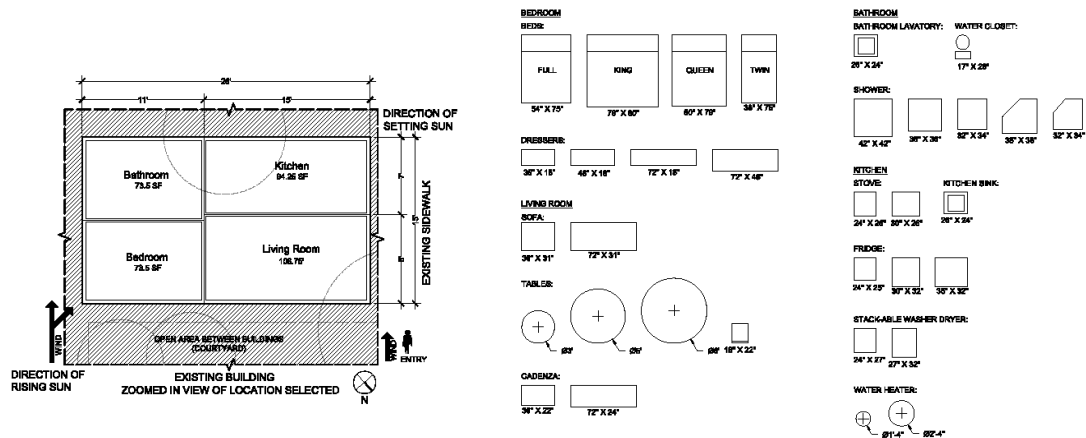

Figure 8.9– Depiction of internal space within example Detached ADU and generic interior components

At this point in the design process, the homeowner begins laying out the components in the ADU that are essential to a home. To create an accurate layout; however, the interior space needs more clarity and dimension. When designing the interior layout, the

drawing first needs to represent the walls in their intended thicknesses. As a conceptual starting point, the design will be using 5 inch thick generic walls as a means to approximate a 2" x 4" stud wall. Offsetting the exterior boundary line inward for wall thickness changes the interior dimensions of the rooms and may fall below the required size allotment. Adjustments should be made to correct these area shortages.

Next, the homeowner must determine which components are essential to the ADU. The IBC has a schedule of plumbing fixtures that are required in dwelling units. This schedule states the dwelling must include at least one water closet, one lavatory, one bathtub or shower, and one kitchen sink.¹⁸⁶ Other features may be necessary but unessential to the dwelling by definition. The homeowner needs to determine what components they want to include. In Figure 8.9 there is a small list of common components and their sizes. The next step in the design is to being the layout of all of the components to be included in the design.

KITCHEN COMPONENT LAYOUT

(Step B.9 refer to Figure 7.1 and Figure 8.1 for complete workflow)

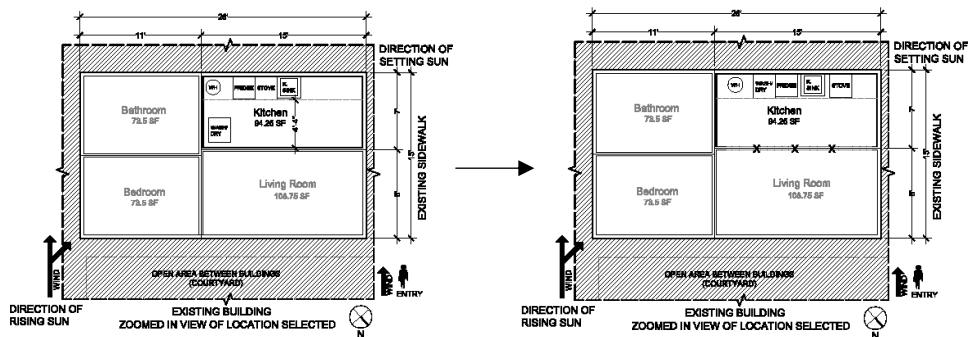

Figure 8.10– Progression of kitchen components in example Detached ADU

The first space to begin laying out is the kitchen. The reason for laying out the kitchen first is that it contains important plumbing fixtures that require a connection to the plumbing system. Laying out these stationary objects first will help the homeowner determine the placement of less restrictive components. The plumbing fixtures need to

¹⁸⁶ Ibid.

connect to a plumbing wall, a.k.a., wet wall, which contains piping necessary to provide plumbing service. These components should be clustered closely together to reduce the distance that connecting pipes travel. Examination through the seven design lenses lead to the above set of adjustments to the kitchen layout.

View/Vista

Align fixtures along one wall to allow plumbing to create a visual relationship between all plumbing entities. Having all plumbing features along one side can allow the individual a means to clearly identify where to search for the component they are seeking.

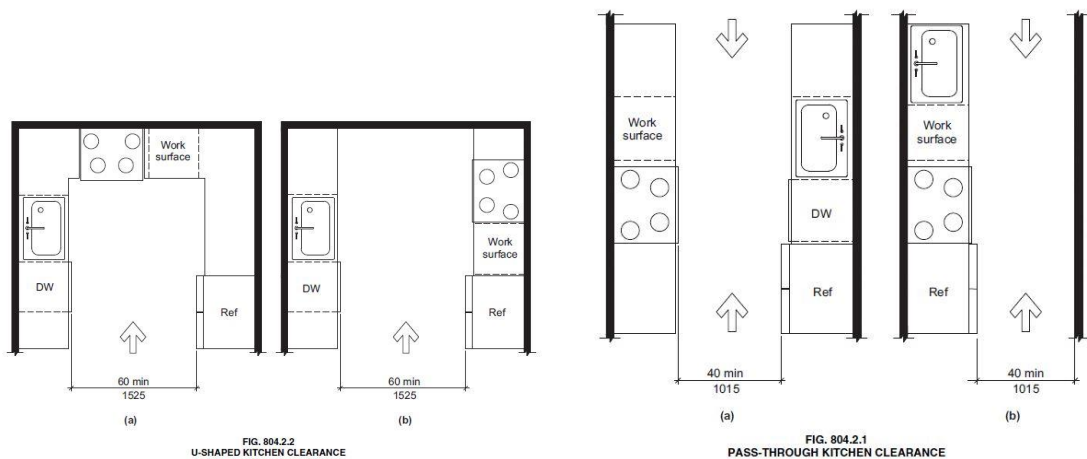

Figure 8.11– Kitchen design clearances standards for accessible kitchens¹⁸⁷

Accessibility/Egress

Though not required, this design references standards established by the ICC A117.1 regarding kitchen layouts. A kitchen is a functional space where individuals handle food and cooking equipment. Safety and convenience in a kitchen are important, and by subscribing to minimal clearance standards referenced in the IBC, the design improves the effectiveness of the space. Above are figures that depict ICC A117.1 standards for kitchen layout.

Ventilation

Opening up the kitchen floor space by removing the dividing wall between the kitchen and the living room, air flows in from the living room into the kitchen increasing the

¹⁸⁷ International Code Council, "Accessible and Usable Buildings and Facilities," (2010).

natural ventilation in the space. By increasing the passive ventilation, the building is less dependent upon active measures for cooling.

Structure

The removal of the dividing wall between the kitchen and the living room will remove a potential support for the roof. Later sections will discuss the specifics of the roof. The removal will, in turn, force the roof to span a greater distance and may increase roof costs. Fire separation requirements based on the use of a room determine whether a separating wall is necessary. For specifics, a homeowner should refer to the IBC. The table below displays fire separation requirements.

**TABLE 508.3.3
REQUIRED SEPARATION OF OCCUPANCIES (HOURS)**

OCCUPANCY	A ^e , E		I		R ^d		F-2, S-2 ^{c,d} , U ^d		B ^b , F-1, M ^b , S-1		H-1		H-2		H-3, H-4, H-5	
	S	NS	S	NS	S	NS	S	NS	S	NS	S	NS	S	NS	S	NS
A ^e , E ^c	N	N	1	2	1	2	N	1	1	2	NP	NP	3	4	2	3 ^a
I	—	—	N	N	1	NP	1	2	1	2	NP	NP	3	NP	2	NP
R ^d	—	—	—	—	N	N	1	2	1	2	NP	NP	3	NP	2	NP
F-2, S-2 ^{c,d} , U ^d	—	—	—	—	—	—	N	N	1	2	NP	NP	3	4	2	3 ^a
B ^b , F-1, M ^b , S-1	—	—	—	—	—	—	—	—	N	N	NP	NP	2	3	1	2 ^a
H-1	—	—	—	—	—	—	—	—	—	—	N	NP	NP	NP	NP	NP
H-2	—	—	—	—	—	—	—	—	—	—	—	—	N	NP	1	NP
H-3, H-4, H-5	—	—	—	—	—	—	—	—	—	—	—	—	—	—	N	NP

For SI: 1 square foot = 0.0929 m².

S = Buildings equipped throughout with an automatic sprinkler system installed in accordance with Section 903.3.1.1.

NS = Buildings not equipped throughout with an automatic sprinkler system installed in accordance with Section 903.3.1.1.

N = No separation requirement.

NP = Not permitted.

a. For Group H-5 occupancies, see Section 903.2.4.2.

b. Occupancy separation need not be provided for storage areas within Groups B and M if the:

1. Area is less than 10 percent of the floor area;
2. Area is equipped with an automatic fire-extinguishing system and is less than 3,000 square feet; or
3. Area is less than 1,000 square feet.

c. Areas used only for private or pleasure vehicles shall be allowed to reduce separation by 1 hour.

d. See Section 406.1.4.

e. Commercial kitchens need not be separated from the restaurant seating areas that they serve.

Figure 8.12– Required separation of spaces based upon occupancy type.¹⁸⁸

Privacy

By removing the barrier wall, there is a greater sense of openness between kitchen and living space creating a more unified whole. A divided kitchen and living space would create an isolation in tasks. A person preparing food in the kitchen may feel more

¹⁸⁸ Council, *International Building Code.*, 81.

secluded or isolated if there were a wall. By breaking down this barrier, the person in the kitchen can continue to engage with comforts attached to the living space.

Cost

The removal of the wall may increase structure and thus the associated cost, but it also removes the framing and finish work associated with the wall in the first places. One benefit of homeowner designs is modifications already incorporate the wants and needs of an informed client.

Daylight

Lastly, by opening up the room, one can effectively make more efficient use of natural daylighting. Morning and afternoon sun that illuminates the living room reflect into the kitchen. Later, the kitchen shares the evening sun with the living room. Once lighting is considered, the homeowner has completed the basic conceptual kitchen layout. It will be refined later.

BATHROOM COMPONENT LAYOUT

(Step B.10 refer to Figure 7.1 and Figure 8.1 for complete workflow)

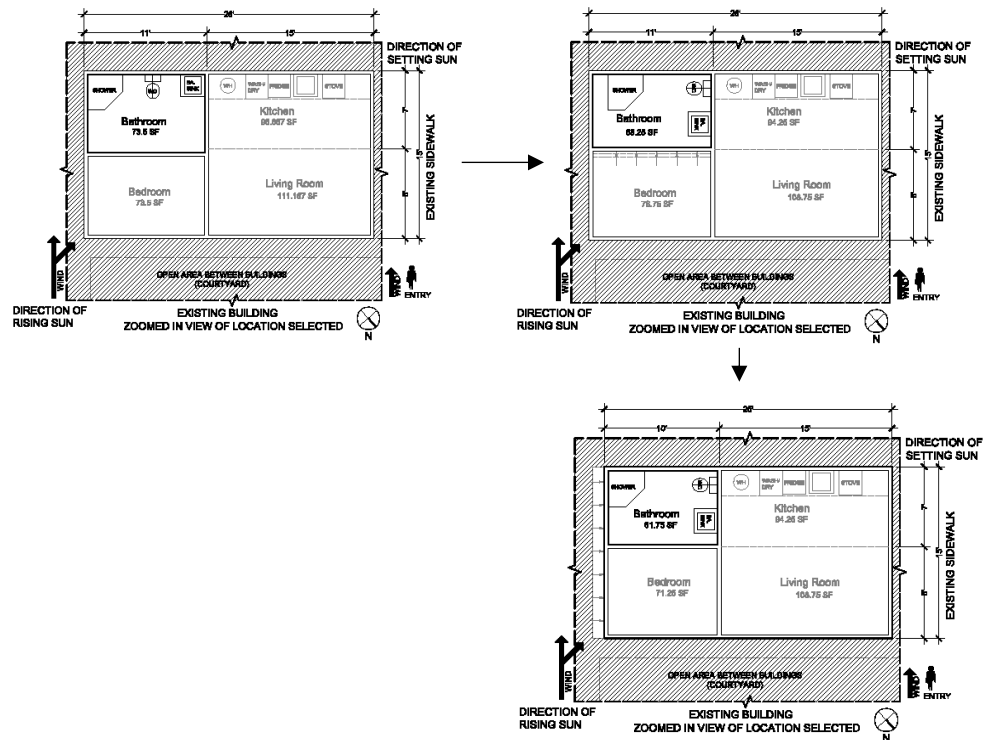

Figure 8.13– Bathroom layout progression for example Detached ADU

The next step is the bathroom layout. Like the kitchen, the bathroom also has plumbing fixtures that are stationary fixtures and need to connect to a plumbing wall. Placing these fixtures in the design first will help determine the space left for other features. Maximize the placement of the plumbing fixtures by clustering to allow for shared use of an adjacent plumbing wall and reduced distance between fixtures to reduce the number of pipes needed.

View/Vista

In the first bathroom layout scheme, fixtures aligned against the wall. However, in the later schemes, the wall on the side of the ADU are moved in. To reduce the crowding of the fixtures, the layout of the bathroom is now radial with the fixtures circumscribing the

occupant. With the central space opened up, the center can act as a sort of pivot point from which the user can make a decision regarding which fixture to use.

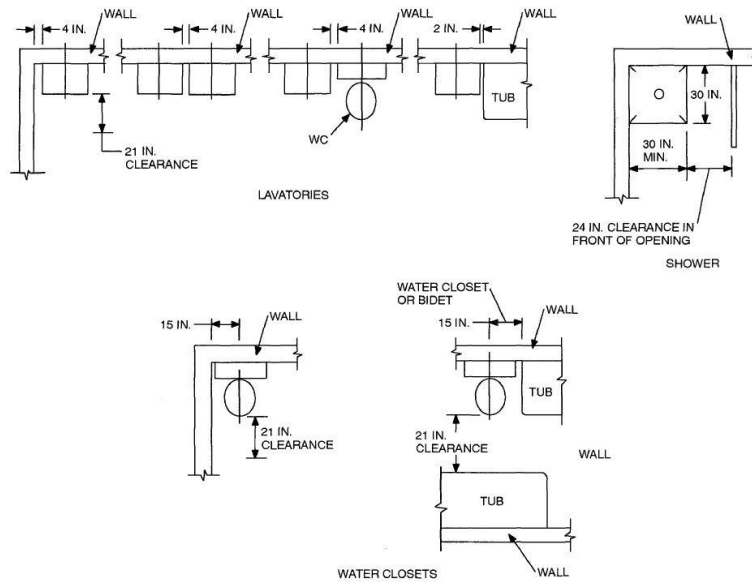

Figure 8.14– Minimum fixture clearances for bathroom layouts.¹⁸⁹

Accessibility/Egress

From the lens of accessibility, the toilet room is often a very difficult space to layout. However, because the toilet room does not need to design for wheelchair accessible, the job is less complicated as it does not need to layout space for a wheelchair turn radius. The IRC 2006 lays out minimum clearances for bathroom fixtures below.

Cost

In the final scheme regarding the layout of the restroom, the floor area decreased by pulling in the side wall. This adjustment reduces the built square footage while effectively reducing the cost of construction.

¹⁸⁹ International Code Council, *International Residential Code* (2006).

BEDROOM COMPONENT LAYOUT

(Step B.11 refer to Figure 7.1 and Figure 8.1 for complete workflow)

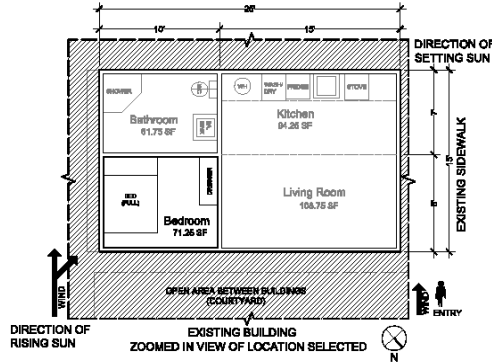

Figure 8.15– Bedroom layout progression for example Detached ADU.

As there are no plumbing fixtures in the bedroom, there are few restrictions to consider when arranging furniture.

View/Vista

If the space permits, the homeowner should arrange the furniture in a way that is visually appealing and clearly orients an individual to the bed and any attached rooms.

Accessibility/Egress

The primary concern is assuring that there is a walking path in the room, especially if it connects to another space. One should be able to maneuver in the space without issue. Ideally, this would result in a 36" clearance space around one side of the bed and connected to any attached room

windows on the wall. (+1)

Option B: Added windows create a possible distraction if the sofa faces the entry. An occupant watching TV but become distracted as something behind the TV begins to move in the background. (-1)

Option C: Like option B, added windows create a possible distraction if the sofa faces the entry. An occupant watching TV but become distracted as something behind the TV moves in the background. (-1)

Accessibility/Egress

Option A: Egress between kitchen and bedroom condense to a single path around the backside of the sofa. (+1)

Option B: Like option "A" egress is condensed to a single path to the side of the sofa and cadenza. (+1)

Option C: Arrangement creates an empty pocket of space near the entry. Additionally, the arrangement turns the space between the sofa and cadenza into a pathway which may disrupt occupants using the sofa to watch a TV placed on the cadenza. (-1)

Total Scores

Option A: +2 (selected)

Option B: +0

Option C: -2

DOOR AND CIRCULATION PLANNING

(Step B.13 refer to Figure 7.1 and Figure 8.1 for complete workflow)

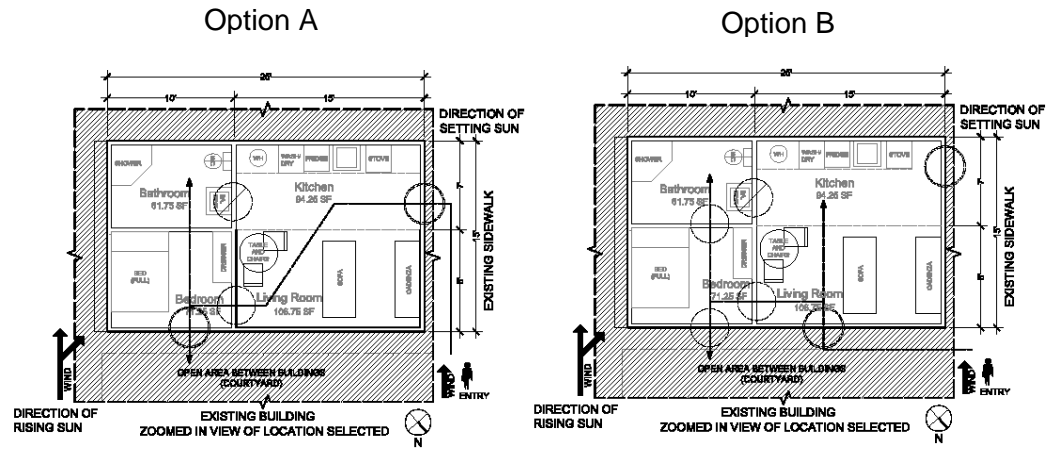

Figure 8.17– Door placement and circulation options for example Detached ADU.

The next step in the workflow is the door and circulation planning. Having considered egress and accessibility in each step, the homeowner should have a general idea of how they intend for people to enter the space. In this step, the homeowner will determine the point of entry into each space. The IBC requires the ADU have two, distantly spaced, exterior entrances.¹⁹⁰ As the design is iterative in nature, the homeowners may need to readjust their designs and take steps backward to accommodate for circulation and entrances. The homeowners should consider the functionality of the doors and the furniture and fixtures surrounding the doorway. The designer needs to assure the operation of a door does not inhibit use in any way.

View/Vista

Option A: The primary door is located at the end of the façade at the farthest point away from the entrance to the property. The primary entrance seems like the secondary door. (-1)

Option B: Placed on the front of the ADU, the primary door faces the primary dwelling. The primary door is close to the entry to the property, though not in the direct path. The secondary door is in the far corner near the back of the ADU and is recognizable as a

¹⁹⁰ Council, *International Building Code*.

secondary door. In a later scheme, this study will address the relationship between the secondary door and the kitchen. (+1)

Accessibility/Egress

Option A: The path of egress is long and not a convenient path to gets the occupant from the entry to the bathroom or bedroom. (-1)

Option B: The path of egress is short and convenient allowing the occupant to get from entry to kitchen or entry to the bathroom in the shortest possible distance. (+1)

Total Scores

Option A: -2

Option B: +2 (selected)

LAYOUT REFINEMENT

(Step B.14 refer to Figure 7.1 and Figure 8.1 for complete workflow)

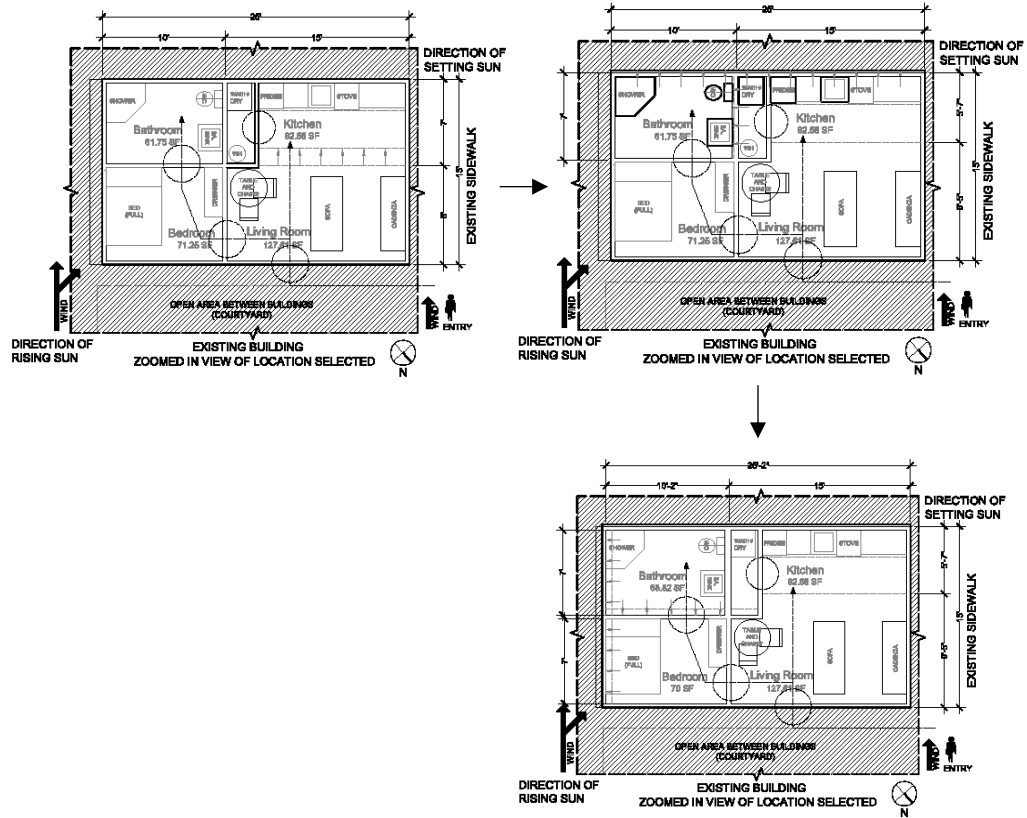

Figure 8.18– Progression of layout refinement for example Detached ADU.

Having established the layout of the ADU, the homeowners may want to modify the layout to optimize the design. Before finalizing the layout, refine the design using the seven design lenses.

View/Vista

When laying out the kitchen, the designer added the water heater and the stackable washer to the design. While bringing these fixtures indoors, the occupants do not want them in the open. The plan was refined to include a storage or utility room next to the kitchen. The homeowners may add rooms to their design provided the gross area does not exceed the limits of the ADU regulation or fall below the IBC room minimums. The

added room will subtract from the kitchen floor space as the kitchen in this design is oversized.

Accessibility/Egress

Regarding egress and accessibility, the modifications maintain the required bathroom clearances, maintain a clear thirty-six inch walking path, and does not obstruct the egress route or the use of any component. Additionally, boundary lines for rooms are shifted to allow for a better allotment of space within the ADU.

Structure

Adjustments to the back wall are needed as it is the plumbing wall supplying water to the plumbing fixtures. The thickness of any wall connected to a plumbing fixture may need to be modified and to accommodate the piping. For conceptual purposes the homeowner should adjust walls connected to plumbing fixtures and increase their size increases from a five-inch generic wall used currently in the design to a seven-inch generic wall. Wall thicknesses will be further refined under the guidance of a design professional.

Cost

The floor area of the ADU was decreased to reduce the amount of built square footage. This was done to reduce the cost of the design.

WINDOW PLANNING

(Step B.15 refer to Figure 7.1 and Figure 8.1 for complete workflow)

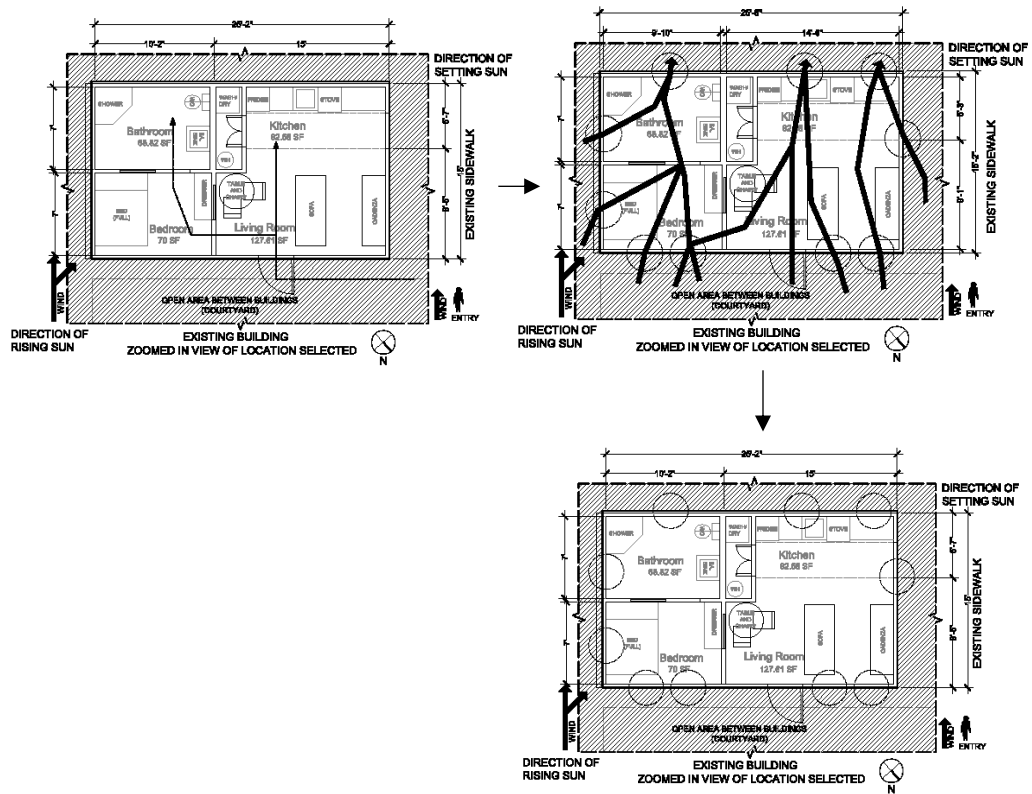

Figure 8.19– Window planning progression for example Detached ADU.

In this step, windows will be planned to create passive ventilation and a cross wind throughout the design. The goal is to create great views that functionally provide light and ventilation. The required open area on the exterior of the building must be 4 percent of the associated room floor area.¹⁹¹ This regulation requires an operable window if pursuing passive ventilation. In the example, if the floor area of the room were 100 square feet, then the window or door area required for that room would be four square

¹⁹¹ Ibid.

feet. Referring to the lighting considerations, the glazed, or glass, the area must be eight percent of the floor area of a room.¹⁹²

View/Vista

Views create a connection from the inside of the dwelling to the outside. Ideal views can frame objects of interest outside the ADU. In the example design, there is a space between the ADU and the existing house. This space can act as a courtyard which can be accented to create a pleasing view.

Accessibility/Egress

When laying out the windows of the ADU, the homeowner must consider fire exits. According to IRC 2006 section R310.1, all sleeping rooms require a fire exit. This exit is an operable opening that must be at a sill height of no greater than 44 inches above the floor. Additionally, it must be at least 20 inches wide, 24 inches tall, and have an area of 5.7 square feet.¹⁹³

In choosing locations for operable windows, one must consider the operation of the window. Windows should open outwards. Nothing outside the ADU should block the window from opening. The windows should also not face any tall object.

Ventilation

Cross ventilation is the best way to create air circulation throughout the inner space of a dwelling. Cross ventilation is a process of staggering openings in the plan so that air must cross the space before leaving through another opening. Openings placed in line with each other create stale or inactive zones within a room because the air will not travel throughout the room and will immediately exit through the least resistive path. The designer must consider the direction of the wind flow to the site when planning the placement of windows. As previously mentioned the primary wind direction is in the Northeast due to the trade winds. In the ventilation lens section it was identified that the primary wind direction in Hawai`i is the from the northeast where the trade winds blow from.

¹⁹² Ibid.

¹⁹³ *International Residential Code*.

The bathroom spaces will need to be mechanically ventilated. There are off the shelf products that can ventilate the bathroom. Get a licensed professional to help with this product.

Structure

When considering the openness of the exterior wall, a balance should be formed where there is not too much surface area eaten away by exterior openings. The opaque areas contain the structure for the building, and if there is not enough structure in a wall, then it will fail to hold up the roof. It is possible to reduce the structural integrity of the wall by increase the glazing content of the wall. Windows require more efficient structural members than plain walls. Increasing structural efficiency may require thicker columns or use of a different material, such as steel. These measures will likely increase the cost of the building. These considerations can be investigated further with a licensed professional. The homeowner should simply understand that more windows may increase the cost of the ADU. Conceptually the homeowner can design the ADU to be constructed in wood and further modifications and material selections can be refined in conjunction with a licensed designer.

Privacy

As glazing creates a transparent or translucent portal to the exterior of the dwelling, the homeowner should assess the use of windows and their ability to create privacy. Windows in bathrooms should be placed up high to prevent unwanted lines of sight. Additionally, homeowners may wish to investigate security measures regarding the use of operable windows.

Cost

The assembly of a window unit is costly so the use of windows should be sparse and strategic.

Daylight

Lastly, the use of daylight should be strategically employed. Place windows in locations that minimize low sun angle glare. The low sun occurs in the evening and morning on the east and west sides of the building respectively. Minimizing openings on these faces

of the building reduce unwanted light. Maximizing openings on the north and south faces can help reduce the heat and improve visual comfort.

ROOF SPAN ANALYSIS

(Step B.16 refer to Figure 7.1 and Figure 8.1 for complete workflow)

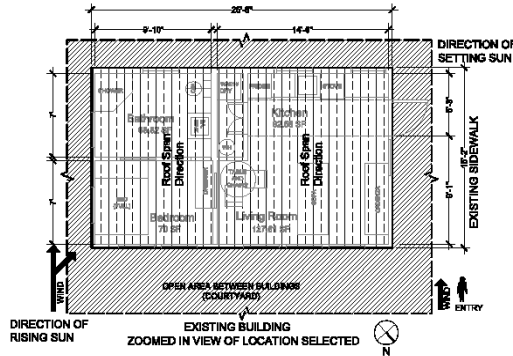

Figure 8.20– Roof span assessment of example design for the Detached ADU.

The next step is roof structure. In this step, the homeowner will establish a preliminary span direction for the roof. The span direction should follow the shorter direction of the building. Spanning the roof in the long direction will increase the structural needs of the roof members and may increase the cost of the roof. It is possible to do so but unadvised. Above is a table that illustrates wood spanning capabilities as a rule-of-thumb. The specific requirements of the design will need further investigation by a licensed profession.

BUILDING SECTION

(Step B.17 refer to Figure 7.1 and Figure 8.1 for complete workflow)

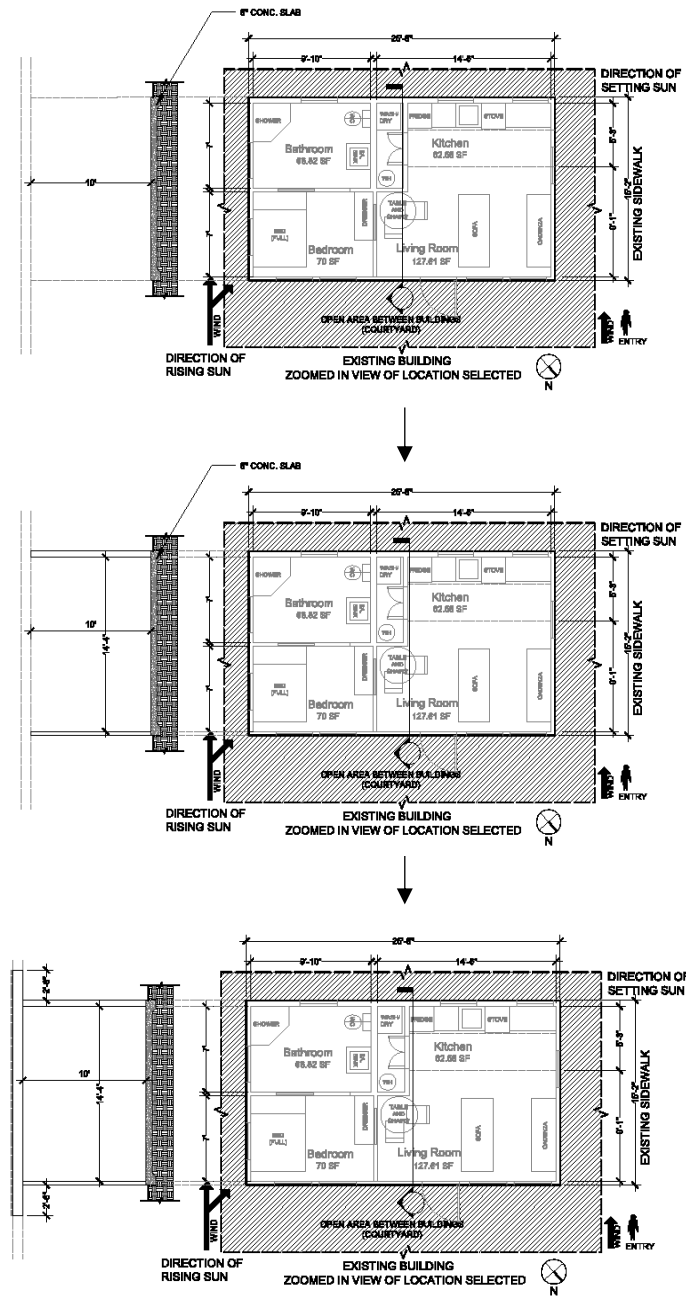

Figure 8.21– Progression of building section drawing for the example Detached ADU.

A building section is a tool used by the construction industry to indicate what a building looks like if one were to cut the building at a specific location and look at it from that

point of view. Imagine a fruit. If someone were to cut the fruit down the middle and then take a picture perpendicular to the cut, the resulting image of the interior of the fruit would be a section view of the fruit. The design profession uses section views to gain insight into a design regarding heights and elevations that they cannot get from the plan view which this system has been using up until now.

This ADU Decision Support System will investigate one section of the building to get a general sense of the design. For a fuller understanding, additional sections will need to be made depicting varying aspects of the design. Cutting the single section can provide a general insight into the design that needs to further expansion upon by the homeowner or a licensed profession. The more the homeowner clarifies the design intent; the more successful the project will be.

The ADU Decision Support System will cut the section along the short direction of the design. This section cut should also not be conflicting with a parallel wall. In the example, the section depicts the ground and a floor structure. For generalization, the design features a 6" concrete slab. The roof is a generic flat roof line displayed at ten feet above the slab surface.

The second diagram extends the lines from the walls in the plan drawing to the roof in the section drawing. These lines will be representative of the walls cut in section. Thus they should have the same thickness as the walls which they represent. The offsets will be a scaled dimension of either five inches or seven inches depending on if the wall contains plumbing.

The last diagram in the sequence defines the roof and its generic thickness based upon the information in Figure 6.3. The roof also extends beyond the wall lines to create an overhanging that will aid in shading the ADU structure.

ROOF PITCH DETERMINATION

(Step B.18 refer to Figure 7.1 and Figure 8.1 for complete workflow)

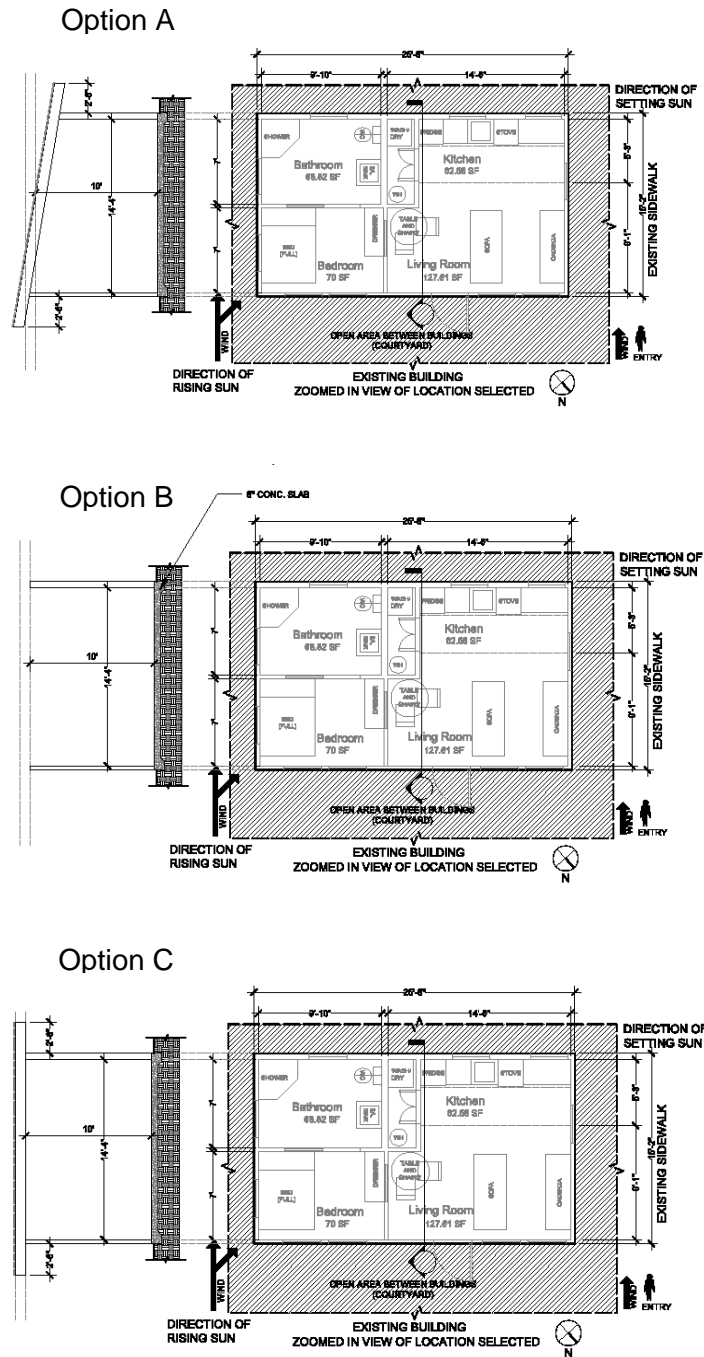

Figure 8.22– Roof pitch options for example Detached ADU.

In this step, the homeowner determines roof pitch. Address the specifics regarding roof slope with a design professional. For conceptual purposes, the example project will use a generic slope of 1:6. This can be used later to estimate the area of the roof.

This example depicts three conceptual schemes. The first scheme option depicts a shed roof pitched away from the existing building. The second scheme option depicts a shed roof pitching towards the existing building. The Third scheme option depicts a double pitched roof bisected in the middle. These three options examine roof pitch through the seven design lenses.

View/Vista

Option A: The roof pitch away from the existing house expands views on the northeast side of the ADU, reinforcing the view of the courtyard (+1)

Option B: The roof pitching toward the existing house decreases views on the northeast side and frames a view of the wall adjacent to the property. (-1)

Option C: This scheme has reduced views in both directions. (-1)

Ventilation

Option A: Roof orientations allows for bigger windows in a direction facing the wind. (+1)

Option B: Roof orientations allows for bigger windows in a direction facing away from the wind. (-1)

Option C: Non-directional equal treatment of window size in both directions. (+0)

Lighting

Option A: Roof orientations allows for greater window wall and daylighting of the bedroom and living room. (+1)

Option B: Roof orientations allows for greater window wall and daylighting of kitchen and bathroom. (-1)

Option C: Equal lighting. (+0)

Total Scores

Option A: +3 (selected)

Option B: -1

Option C: -1

SECTION REFINEMENT

(Step B.19 refer to Figure 7.1 and Figure 8.1 for complete workflow)

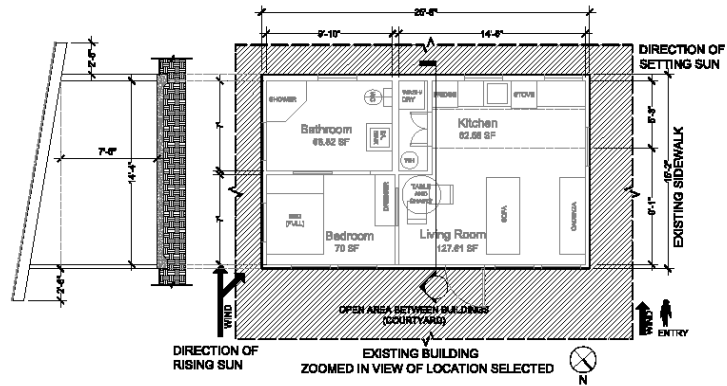

Figure 8.23– Refined section drawing for the example Detached ADU.

In this step, the roof height and slope can be changed to fit the needs of the project. There are two restrictions, however, that need consideration at this stage.

According to IBC Section 1208.2, “[o]ccupiable spaces, habitable spaces and corridors shall have a ceiling height of not less than 7 feet 6 inches.”¹⁹⁴

According to the Land Use Ordinance and the ADU development requirements, ADUs have a height limit of 25 feet.¹⁹⁵

¹⁹⁴ *International Building Code.*

¹⁹⁵ Honolulu, "Chapter 21: Land Use Ordinance."

CONSTRUCTION SYSTEMS APPLICATION

(Step B.20 refer to Figure 7.1 and Figure 8.1 for complete workflow)

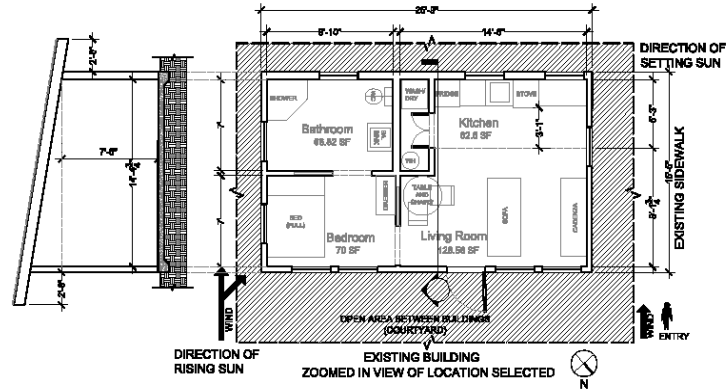

Figure 8.24– Final design drawings (plan and section) for the example Detached ADU.

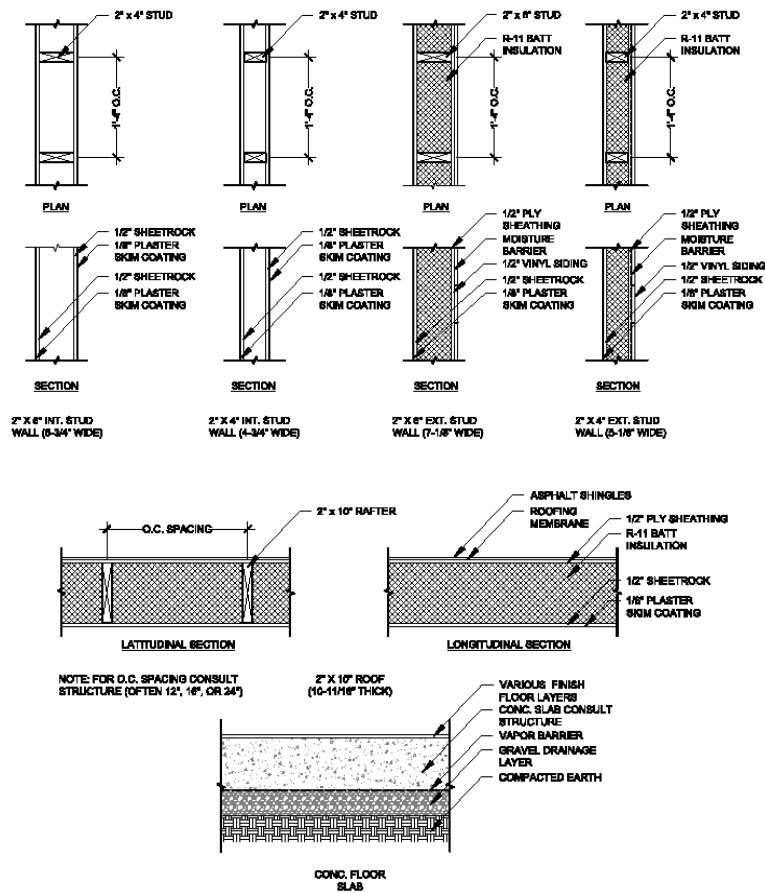

Figure 8.25– Typical details to be referenced or modified when applying construction systems to final drawings.

In the final design step, the homeowner applies real thicknesses to the generic wall and ceiling types used so far.

The example design features a low-cost construction assembly. The typical details in Figure 8.25 will be the basis for the construction and finishes used in this example. Modifications can be made but should also be explored in their construction assembly. Interior walls become interior partitions faced with two sides of gypsum board. Gypsum wallboard faces the exterior walls on the inside. Vinyl siding covers the exterior side of the wall. Remember that walls with plumbing lines will be thickened to use a six-inch stud while non-plumbing walls will use a four-inch stud. The floor construction consists of a finish laminate floor on top of a poured in place reinforced concrete slab. The slab has a reinforced edge at the perimeter of the ADU. The roof construction consists of wooden joists at the depth previously determined that is faced on the inside with a plaster finish and faced to the exterior with the various roofing layers. Typical details provided above. The use of these affordable construction assemblies will assist the homeowner in the cost analysis of the design.

CONCEPTUAL MATERIAL TAKEOFF

(Step B.21 refer to Figure 7.1 and Figure 8.1 for complete workflow)

The final step in the design for the Detached ADU is the material takeoff. In this step, basic sizes and dimensions are examined to determine the quantities of materials used by the design. In the cost analysis section, the homeowner attributes financial rates to the quantities determined in the material takeoff step. This step is essential in generating information about the design from which to assess the effectiveness of the ADU concept.

As previously explored, this study applied typical construction assemblies to the conceptual prototype. These assemblies are an aggregate of various construction materials. Homeowners can use the assemblies to estimate the cost of the ADU design. This cost is just an estimate. A precise cost is not necessary for the process of validating a design concept. Rather broad estimates based on the assemblies can be used in the material take off step. The quantities recorded will either be a basic count (each, ea.), an area quantity (square feet, sf.), or a quantity based upon a linear measurement (linear

feet, lf.). The types of materials used in the table do not need to remain the same. The designers can use a multitude of other types of materials in the assembly granted they have a cost rate and an installation rate. This material takeoff establishing quantities used in conjunction with RSMMeans Square Foot Costs 2010.

Table 8.2- Table for homeowner to expand upon for the estimation of materials in the design

Subject	Type	Quantity	Units
Counter Top	Laminate		LF.
Cabinet	Vanity Cabinet		EA.
Ceiling	Gypsum on Wooden Support		SF.
Doors	Single-Flush		EA.
Floor	Laminate		SF.
Electrical	Fixtures per Total Built Area		SF.
Kitchen Sink	Double Bowl		EA.
Bathroom Layout	Full layout 3 Fixtures (Toilet, Sink, Shower)		EA.
Water Heater	Electric		EA.
Range/Stove	Built-in		EA.
Washing Machine	Stacked Automatic		EA.
Refrigerator	Economy		EA.
Roof	Asphalt-Shingle		SF.
Foundation	Cast-in-place Concrete		SF.
Slab Edge	Building Perimeter		LF.
Wall	Interior (5"/7") / Exterior (5"/7")		SF.
Windows	Louver		EA.

CHAPTER 9 : DESIGN WORKFLOW FOR AN ATTACHED MODIFIED ADU

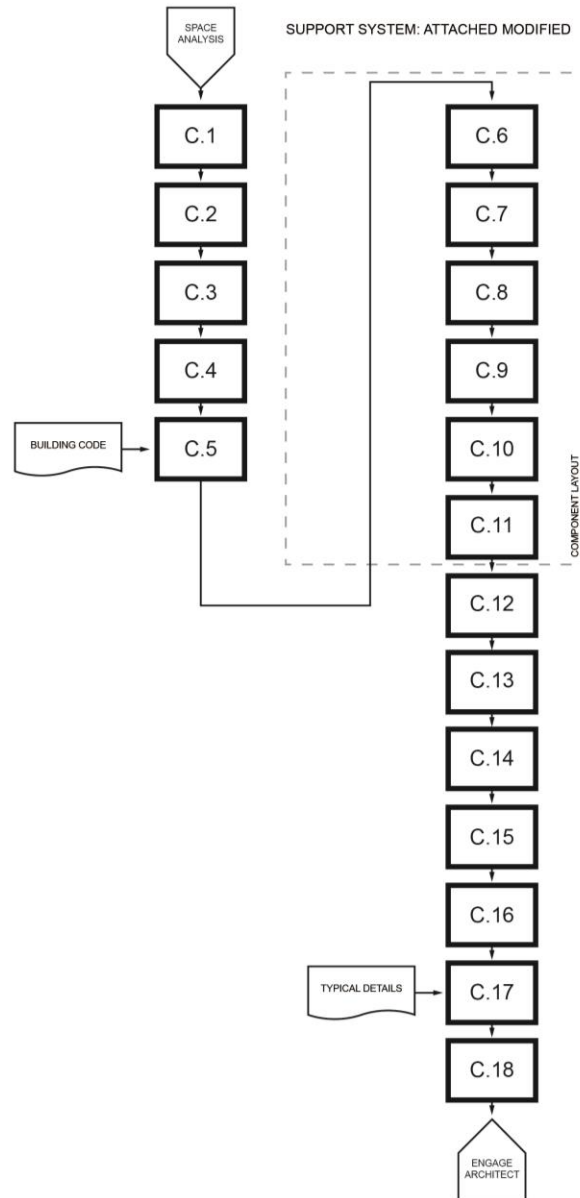

Figure 9.1– Workflow diagram showing the design procedures for an Attached Modified ADU.

Table 9.1 – Reference steps for Figure 9.1

C.1	Existing Space Analysis
C.2	Existing Space Strategy
C.3	Internal Division Analysis
C.4	Internal Layout Planning
C.5	Internal Layout Refinement
C.6	Identify Necessary Components
C.7	Kitchen Component Layout
C.8	Bathroom Component Layout
C.9	Bedroom Component Layout
C.10	Living Room Component Layout
C.11	Door and Circulation Planning
C.12	Layout Refinement
C.13	Window Planning
C.14	Roof Span Analysis
C.15	Building Section
C.16	Section Refinement
C.17	Construction Systems Application
B.18	Conceptual Material Takeoff

EXISTING SPACE ANALYSIS

(Step C.1 refer to Figure 7.1 and Figure 9.1 for complete workflow)

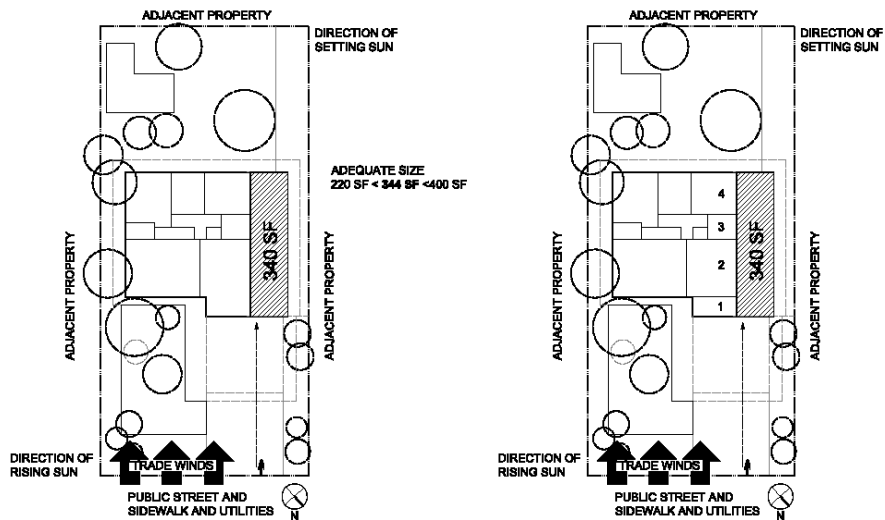

Figure 9.2– Analysis drawing of existing spaces within the dwelling unit for planning of the example Attached Modified ADU

The first step in the design workflow for an “Attached Modified ADU” is the analysis of existing space. In previous existing physical feature analysis, the homeowner has

already identified if a covered patio or carport exists. The ADU will repurpose this covered area into its roof. To make sure that the covered location is suitable for an ADU, the covered area needs a minimum of 220 square feet without having to extend the roof area. If the area is larger than 400 square feet and the property is smaller than 4999 square feet, only a portion of the roofed area will be used.

In evaluating the existing space, the homeowners must also assess the adjacent rooms and internal spaces within the existing building next to the covered patio or carport. The design must recognize the attributes that are the functions of the spaces themselves. By what means of ventilation is used to service the spaces, if any? Do the spaces have windows? How is the space receive lighting?

Habitable spaces require ventilation according to the International Mechanical Code.¹⁹⁶ A dwelling can employ either passive or active ventilation methods. When designing a unit that will abut an existing space, the homeowner must determine how the placement of the ADU will impact the ventilation of the existing dwelling. In the case where the installation of the ADU removes a window from the existing residence and the primary ventilation strategy used was passive ventilation, the existing room must employ a new strategy of ventilation. A new window or a new active mechanical system can be installed.

Regarding lighting, the IBC requires that spaces have light, either artificial or natural. When placing a new space adjacent to an existing space and a daylight portal is removed, the homeowner must develop a strategy to deal with lighting the existing space. The owner can either create a new natural daylight portal to offset energy use throughout the day, or commit to the use of full artificial lighting of the existing space.

Below is an assessment of the example design and the existing spaces that are affected by the development of a new ADU.

¹⁹⁶ International Code Council, "International Mechanical Code," (2006).

Table 9.2 – Assessment of existing building spaces adjacent to the proposed ADU in the example design.

#	Use	Windows	Ventilation	Lighting
1	Storage	No Windows	No Ventilation	Artificial Lighting
2	Kitchen	Has Windows	Passive Ventilation	Natural and Artificial Lighting
3	Restroom	Has Windows	Mechanical Ventilation	Natural and Artificial Lighting
4	Bedroom	Has Window	Passive Ventilation	Natural and Artificial Lighting

EXISTING SPACE STRATEGY

(Step C.2 refer to Figure 7.1 and Figure 9.1 for complete workflow)

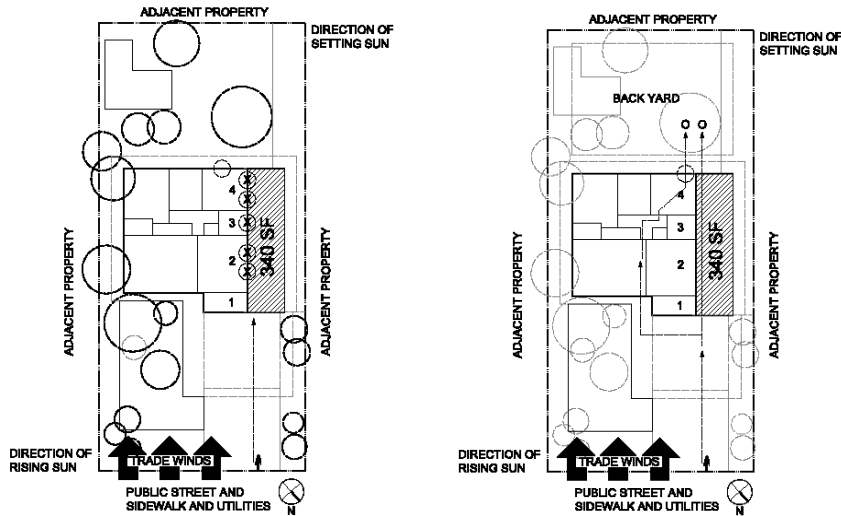

Figure 9.3 – Proposed modifications to existing dwelling unit to accommodate the new Attached Modified ADU on the example site.

Having assessed the spaces within the existing building, the homeowner should develop a strategy to mitigate any issues regarding the ventilation and lighting of these spaces that may arise due to the placement of a new “Attached Modified ADU.”

In the example design, the kitchen will need to employ a new mechanical system as previously the kitchen utilized passive ventilation. The restroom already employed a mechanical system, so it does not need to change. The bedroom will still have a window opening and can continue to make use of passive ventilation strategies. Lastly, the storage space did not require ventilation as it is not a habitable space. A summary of ventilation strategies is listed below in figure

Table 9.3 – Proposed ventilation strategy for the example Attached Modified ADU design.

	Name	Windows	Ventilation	Strategy
	Storage	No Windows	No Ventilation	No Ventilation
	Kitchen	Has No Windows	Passive Ventilation	Mechanical Ventilation
	Restroom	Has No Windows	Mechanical Ventilation	Mechanical Ventilation
	Bedroom	Has Window	Passive Ventilation	Passive Ventilation

Regarding lighting, the kitchen will employ a new skylight. Though the kitchen already has an artificial lighting system, the use of a skylight can offset energy usage throughout the day. The restroom will make use of the artificial lighting already in place. The bedroom will make use of both passive and active lighting as it retains the window to the rear of the property. Lastly, the storage unit remains unmodified. A summary of lighting strategies employed for this design are listed below.

Table 9.4 – Proposed lighting strategy for the example Attached Modified ADU design.

	Name	Windows	Lighting	Strategy
	Storage	No Windows	Artificial Lighting	Artificial Lighting
	Kitchen	Has No Windows	Natural and Artificial Lighting	Natural and Artificial Lighting
	Restroom	Has No Windows	Natural and Artificial Lighting	Artificial Lighting
	Bedroom	Has Window	Natural and Artificial Lighting	Natural and Artificial Lighting

INTERNAL DIVISION ANALYSIS

(Step C.3 refer to Figure 7.1 and Figure 9.1 for complete workflow)

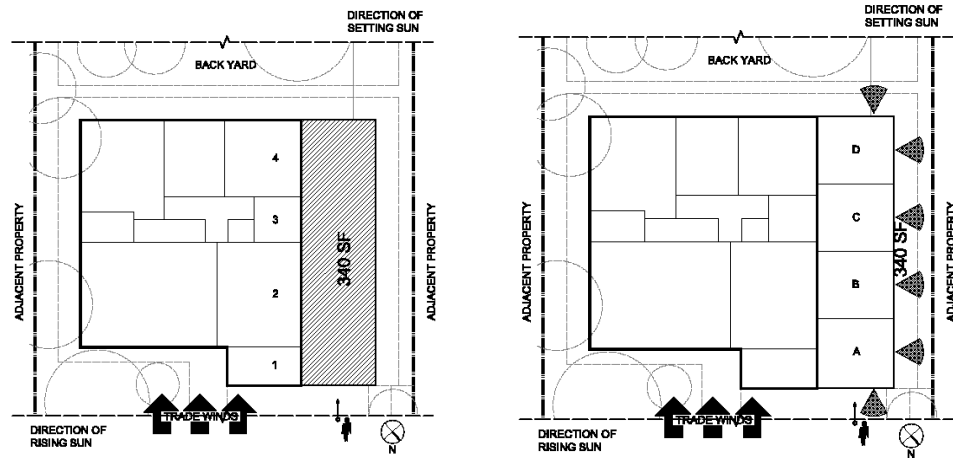

Figure 9.4– Division of space within proposed ADU area to assess benefits and drawbacks within the design for an Attached Modified ADU on the example site.

After taking care of the existing building, the homeowner can begin to investigate the design for the ADU. Begin by evaluating the locations within the covered area for benefits and drawbacks. Subdivide the proposed area into four equal quadrants, and label each quadrant with a nondescript label, A, B, C, and D. Then, evaluate each quadrant through the considerations of the seven design lenses.

View/Vista

Quadrant A: This quadrant has a view of the point of entry of the property and approaching foot traffic.

Quadrant B: This quadrant only has a view to the side of the dwelling.

Quadrant C: This quadrant only has a view to the side of the dwelling.

Quadrant D: This quadrant has a view to the rear of the property and the back yard.

Accessibility/Egress

Quadrant A: This quadrant is closest to the point of entry of the property and access to the public right-of-way.

Quadrant B: Path of egress must flow through quadrant A to get to quadrant B.

Quadrant C: Path of egress must flow through quadrants A, and B to get to quadrant C.

Quadrant D: Path of egress must flow through quadrants A, B, and C to get to quadrant D.

Ventilation

Quadrant A: This quadrant has direct wind access from the northeast trade wind direction.

Quadrant B: Air flowing into this location must flow through quadrant A or come in from the northwest facing side.

Quadrant C: Air flowing into this location must flow through quadrants A and B or come in from the northwest facing side.

Quadrant D: Like B and C, the air flowing into this location must flow through quadrants A, B, and C or come in from the northwest facing side of the ADU.

Privacy

Quadrant A: This quadrant is the closest to the street and is most public.

Quadrant B: To get to quadrant B, occupant must go through quadrant A in the front or quadrants D and C in the rear. This quadrant is private.

Quadrant C: Like B, occupant must go through other spaces to get to quadrant C. This quadrant is private..

Quadrant D: This quadrant is furthest from the street but is open to the back yard. This quadrant is semi-private

Lighting

Quadrant A: This quadrant is under cover of the patio and is adjacent to the covered carport. This quadrant only receives reflected lighting.

Quadrant B: Like A, the covered patio reduces direct penetration of light and thus this quadrant will only receive reflected lighting.

Quadrant C: Like A, the covered patio reduced direct penetration of light and thus this quadrant will only receive reflected lighting.

Quadrant D: Unlike the other quadrants, this quadrant faces the yard and the direction of the setting sun. Low evening light will penetrate the room.

Having analyzed the qualities of the quadrants within the proposed dwelling envelope, the homeowner can assign household rooms to the quadrants based on functional needs of each room.

Living Room

Required size: 120 square feet minimum¹⁹⁷

Privacy needs: Public functionality

Ideal location: Quadrant A

Bedroom

Required size: 70 square feet minimum¹⁹⁸

Privacy needs: Semi-Private functionality

Ideal location: Quadrant D

Kitchen

Required size: 50 square feet minimum¹⁹⁹

Privacy needs: Semi-Private functionality

Ideal location: Quadrant B, Quadrant C

Restroom

Required size: N/A

Privacy needs: Private functionality

Ideal location: Quadrant B, Quadrant C

¹⁹⁷ Council, *International Building Code*.

¹⁹⁸ Ibid.

¹⁹⁹ Ibid.

INTERNAL LAYOUT PLAN

(Step C.4 refer to Figure 7.1 and Figure 9.1 for complete workflow)

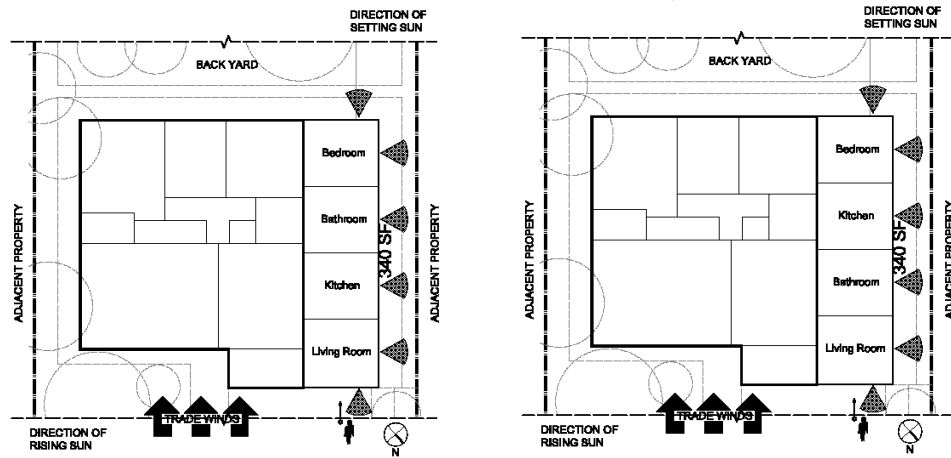

Figure 9.5– Layout alternatives for internal spaces in the example Attached Modified ADU design.

Following the analysis of ideal locations, the homeowner must decide the possible layout schemes that will create an ideal layout plan. In the example property, the owners decided the quadrants of the living room and bedroom, but the quadrants for the kitchen and restroom must be decided. Below is the analysis of the two proposed layout schemes.

Accessibility/Egress

Option A: Regarding occupant circulation and access, this scheme groups the bathroom with the bedroom and the kitchen with the living room. These pairings creates an ideal relationship as the functions of kitchen and living space can be combined, as in the efficiency dwelling prototype. (+1)

Option B: This scheme clusters the bathroom with the living room and the kitchen with the bedroom. This arrangement creates and unusual pairing of spaces. Usually, houses pair bathrooms with bedrooms rather than kitchens. (-1)

Total Scores

Option A: +1 (selected)

Option B: -1

INTERNAL LAYOUT REFINEMENT

(Step C.5 refer to Figure 7.1 and Figure 9.1 for complete workflow)

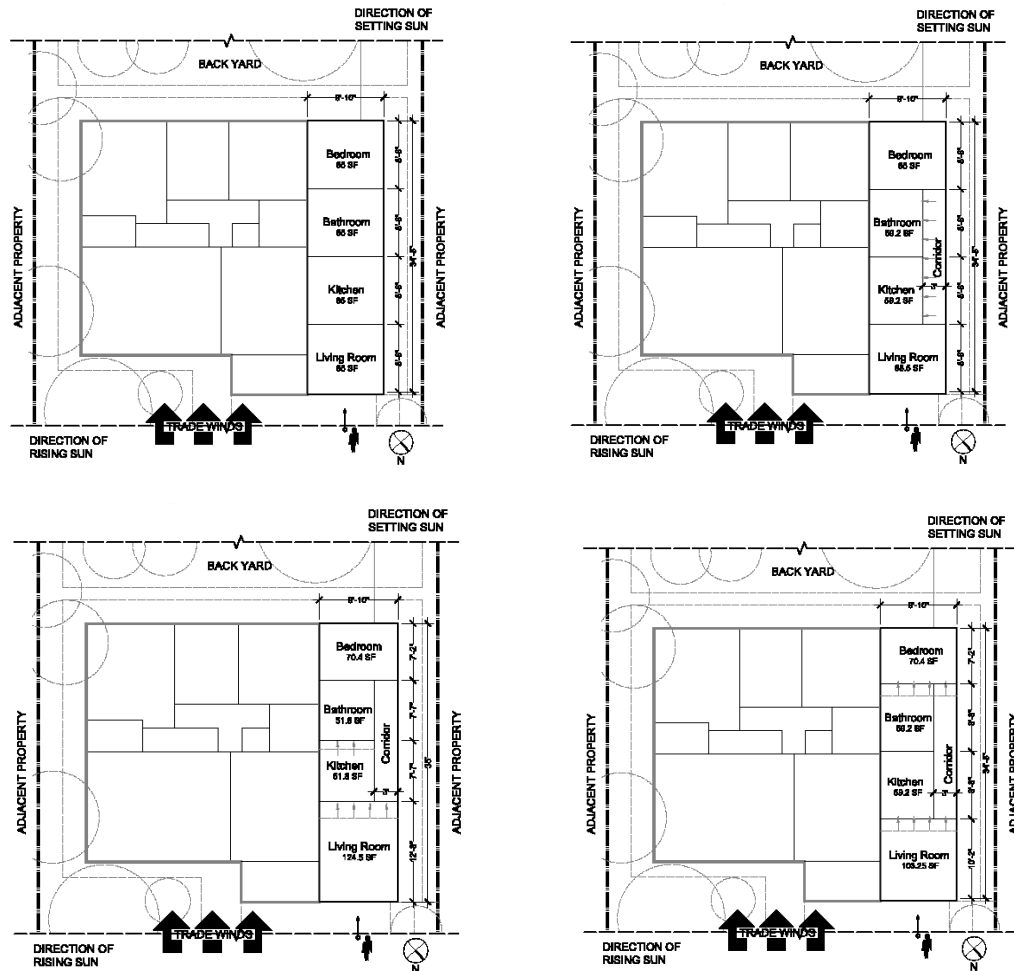

Figure 9.6– Progression of layout refinement modifications in the example design for the Attached Modified ADU.

The next step is to refine the allocation of space within the ideal layout plan previously determined. Different household rooms have certain square footage requirements according to the IBC. The designer must revise the divisions of space because in current layout all the rooms have equal amounts of area.

Space Requirements for Rooms

Living room – 120 square feet minimum (increase allotment)

Bedroom – 70 square feet minimum (decreases allotment)

Kitchen – 50 square feet minimum (decrease allotment)

Restroom – N/A (decrease allotment)

Additionally, in this refinement stage, it may be be beneficial to further adjust spaces by evaluating through the seven design lenses

Accessibility/Egress

The primary consideration in this refinement is the creation of a corridor to the bedroom from the living room. According to the IBC, an egress path should not go through spaces such as storages, kitchens, and bathrooms.²⁰⁰ To avoid having the egress path run through those rooms, the designer created a path and the kitchen and restroom moved to the side. Additionally, the sizes of the rooms are adjusted to meet the minimum space requirements for a dwelling unit.

IDENTIFY NECESSARY COMPONENTS

(Step C.6 refer to Figure 7.1 and Figure 9.1 for complete workflow)

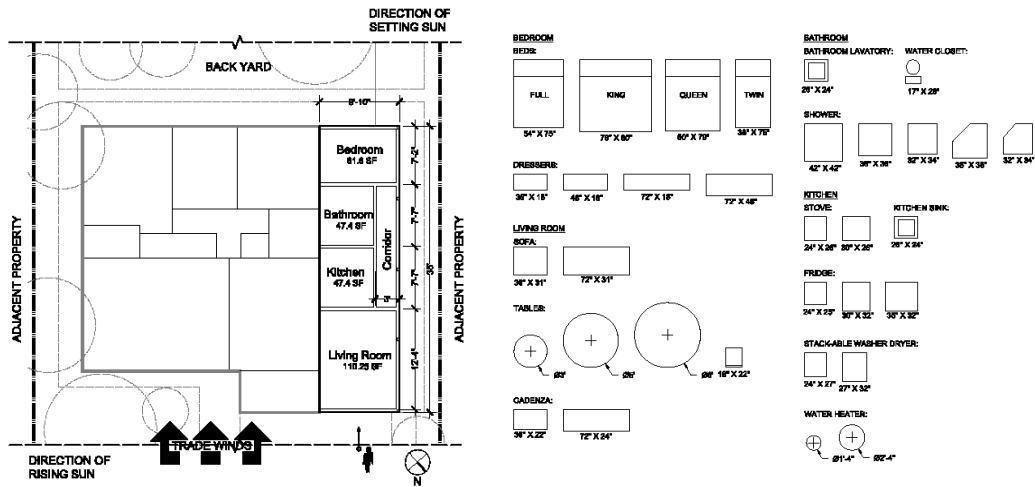

Figure 9.7– Depiction of internal space within example Attached Modified ADU and generic interior components.

At this point in the design process, the homeowner begins laying out the components in the ADU that are essential to a home. To create an accurate layout, the interior spaces need more clarity and dimension. When designing the interior layout, the drawing first needs to represent the walls in their intended thicknesses. As a conceptual starting point

²⁰⁰ Ibid.

the design will use 5 inch thick generic walls as a means to approximate a 2" x 4" stud wall. Offsetting the exterior boundary line inward for wall thickness, the interior dimensions of the rooms will change and may fall below the required size allotment. Adjustments should be made to correct these area shortages.

As in the Identification of Necessary Components explored in the design of the detached ADU, the homeowner must determine which components are essential to the ADU. The IBC has a schedule of plumbing fixtures that are required in dwelling units. This schedule states the dwelling must include at least one water closet, one lavatory, one bathtub or shower, and one kitchen sink²⁰¹. Beyond the required plumbing fixtures, Figure 9.7 includes a small list of common components and their sizes. The next step in the design is to begin the layout of all of the components to be included in the design.

²⁰¹ Ibid.

KITCHEN COMPONENT LAYOUT

(Step C.7 refer to Figure 7.1 and Figure 9.1 for complete workflow)

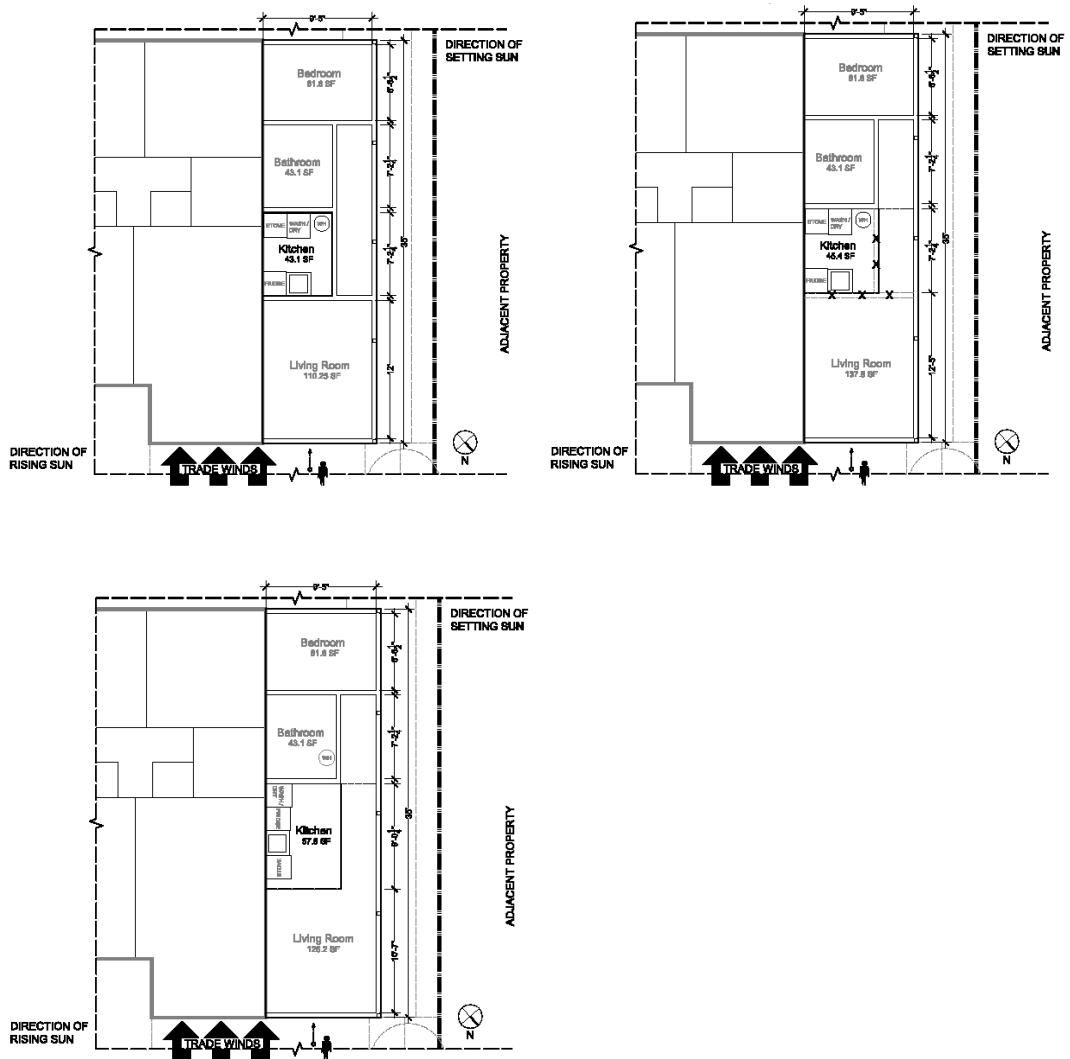

Figure 9.8– Kitchen layout progression for the design of the example Attached Modified ADU design.

The first space to begin laying out is the kitchen. The reason for laying out the kitchen first is that it contains important plumbing fixtures that require a connection to the plumbing system. Laying out these stationary objects first will help the homeowner determine the placement of less restrictive components. The plumbing fixtures need to connect to a plumbing wall, a.k.a. wet wall, which contains piping necessary to provide plumbing service. These components should be clustered closely together to reduce the

distance that connecting pipes travel. Examination through the seven design lenses lead to the above set of adjustments to the kitchen.

Accessibility/Egress

Though not required, this design references standards established by the ICC A117.1 regarding kitchen layouts. A kitchen is a functional space where individuals handle food and cooking equipment. Safety and convenience in a kitchen are important, and by subscribing to minimal clearance standards referenced in the IBC, the design improves the effectiveness of the space. Refer to figure Figure 8.11 which depicts ICC A117.1 standards for kitchen layout.

Ventilation

Opening up the kitchen floor space by removing the dividing wall between the kitchen and the living room, air flows in from the living room into the kitchen increasing the natural ventilation in the space.

Structure

Fire separation requirements based on the use of a room determine whether a separating wall is necessary. For specifics, a homeowner should refer to the IBC. See Figure 8.12 for specific requirements.

Privacy

By removing the barrier wall, there is a greater sense of openness between kitchen and living space creating a more unified whole. A divided kitchen and living space would create an isolation in tasks. A person preparing food in the kitchen may feel more secluded or isolated if there were a wall. By breaking down this barrier, the person in the kitchen can continue to engage with comforts attached to the living space.

Cost

The covered carport or patio already has a supported roof. Therefore, removal of the intermediate wall does not destabilize the structure. It does, however, removes the framing and finish work associated with the wall in the first places. One benefit of homeowner designs is modifications already incorporate the wants and needs of an informed client.

Daylight

Lastly, by opening up the room, one can effectively make more efficient use of natural daylighting. Light in the living room can be reflected into the kitchen.

BATHROOM COMPONENT LAYOUT

(Step C.8 refer to Figure 7.1 and Figure 9.1 for complete workflow)

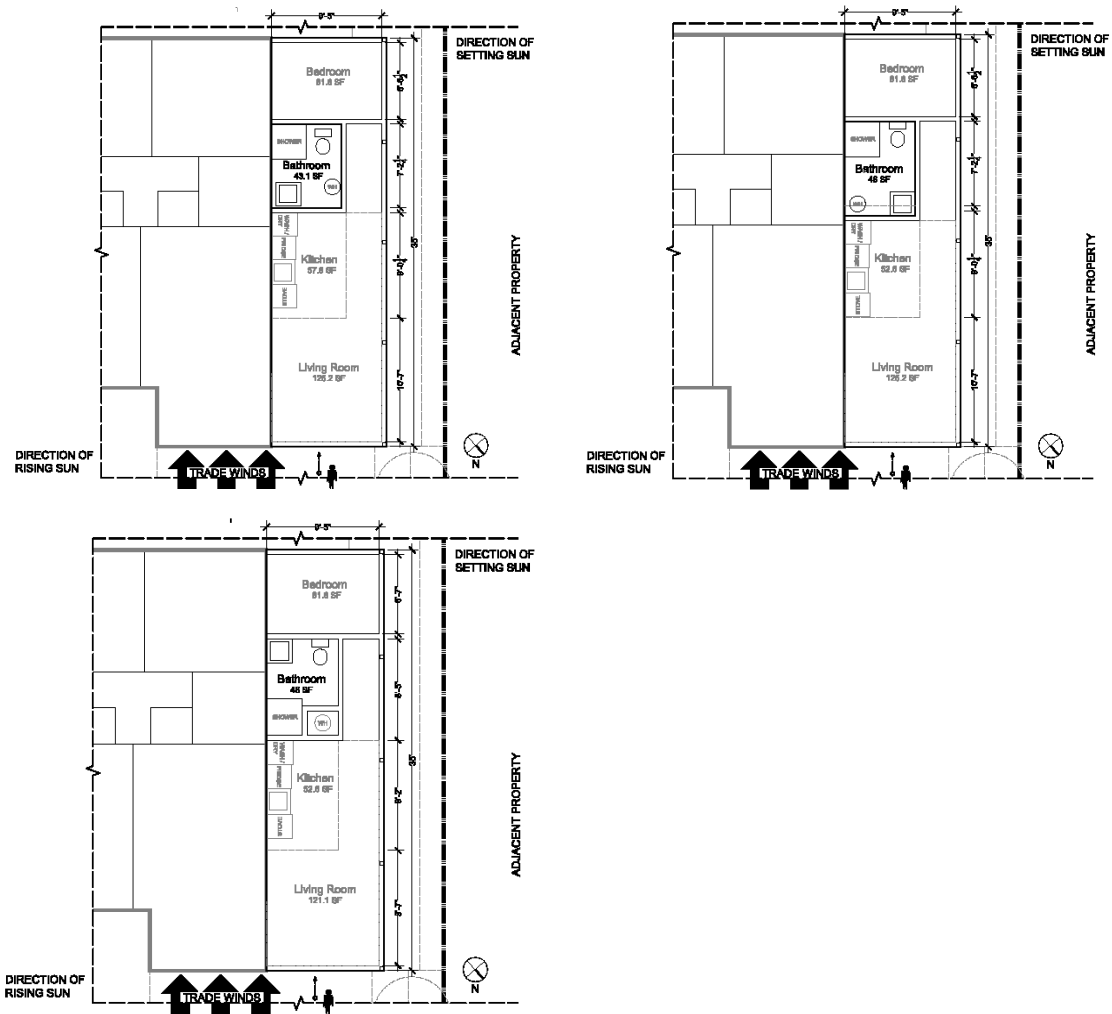

Figure 9.9– Progression of a bathroom layout in the example Attached Modified ADU design.

The next step is the bathroom. Like the kitchen, the bathroom also has plumbing fixtures that are stationary fixtures and need to connect to a plumbing wall. Placing these fixtures in the design first will help determine the space left for other features. Maximize the placement of the plumbing fixtures by clustering to allow for shared use of an adjacent

plumbing wall and reduced distance between fixtures to reduce the number of pipes needed.

View/Vista

The layout of the bathroom is in a radial arrangement with the fixtures circumscribing the occupant. With the central space opened up, the space can act as a sort of pivot point from which the user can make a decision regarding which fixture to use.

Accessibility/Egress

From the lens of accessibility, the toilet room is often a very difficult space to layout. However, because the toilet room does not need to design for wheelchair accessible, the job is less complicated as it does not need to layout space for a wheelchair turn radius. The IRC 2006 lays out minimum clearances for bathroom fixtures. See Figure 8.14.

BEDROOM COMPONENT LAYOUT

(Step C.9 refer to Figure 7.1 and Figure 9.1 for complete workflow)

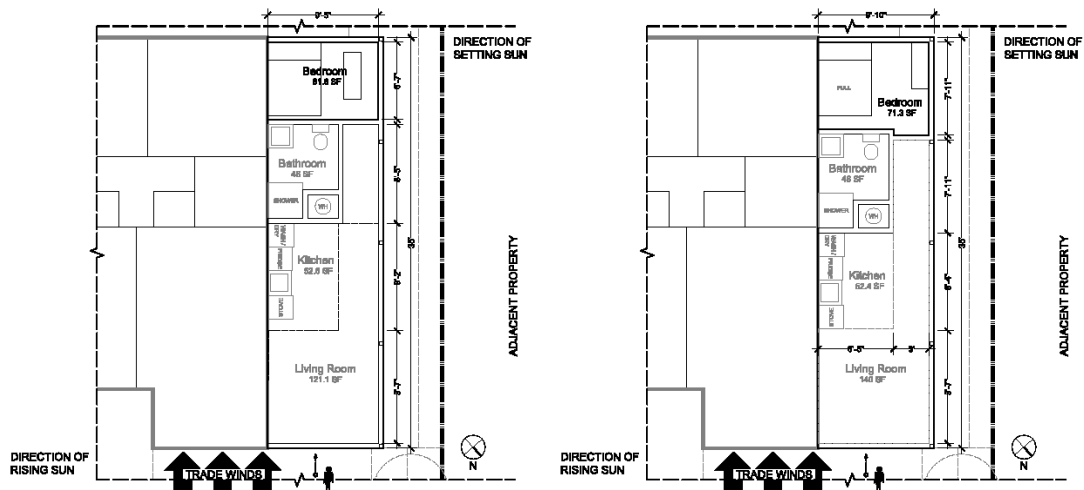

Figure 9.10– Progression for a bedroom component layout in the example Attached Modified ADU design.

As there are no plumbing fixtures in the bedroom, there are few restrictions to consider when arranging furniture.

View/Vista

If the space permits, the homeowner should arrange the furniture in a way that is visually appealing and clearly orients an individual to the bed and any attached rooms.

Accessibility/Egress

The primary concern is assuring that there is a walking path in the room, especially if it connects to another space. One should be able to maneuver in the space without issue. Ideally, this would result in a 36" clearance space around one side of the bed and connected to any attached room

LIVING ROOM COMPONENT LAYOUT

(Step C.10 refer to Figure 7.1 and Figure 9.1 for complete workflow)

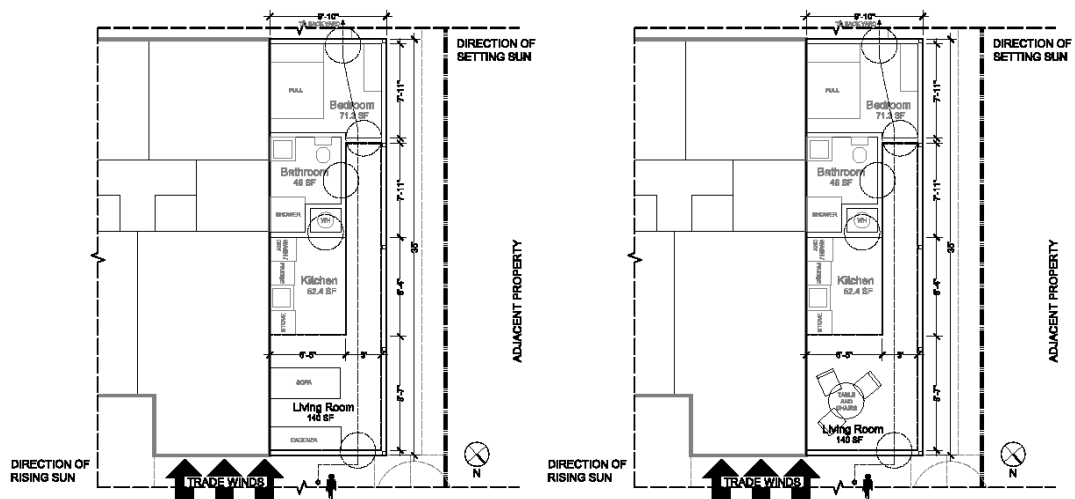

Figure 9.11– Progression for a living room layout in the example Attached Modified ADU design.

Like the layout of the bedroom, plumbing fixtures do not dictate the living room arrangement. The primary concern is the ability for occupants to circulation around furniture.

Accessibility/Egress

Option A: Sofa takes up most of the living space (-1)

Option B: Small table and chairs allows for a variable furniture layout accommodating more people without getting in the way of functional egress paths. (+1)

Total Scores

Option A: -1

Option B: +1 (selected)

DOOR AND CIRCULATION PLANNING

(Step C.11 refer to Figure 7.1 and Figure 9.1 for complete workflow)

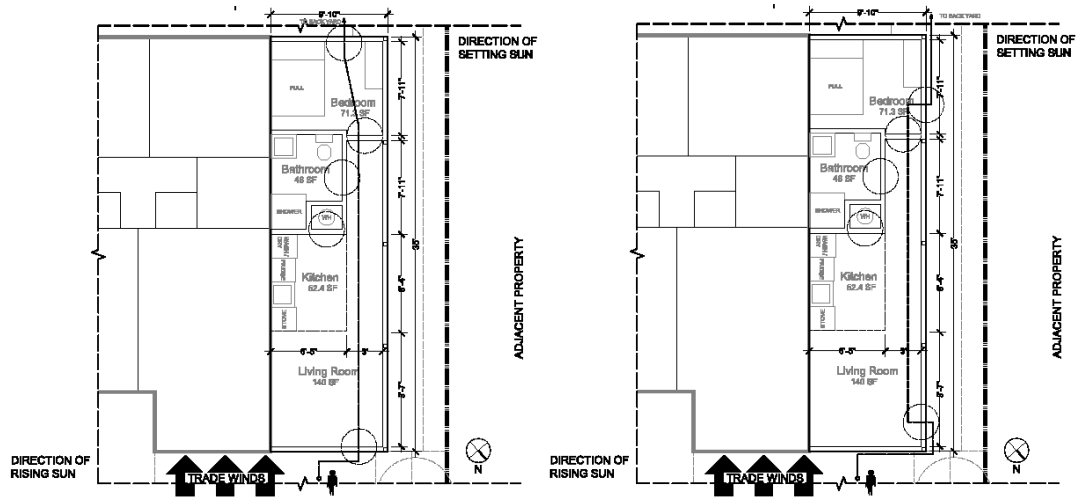

Figure 9.12 – Door placement and circulation options for the example Attached Modified ADU.

The next step in the workflow is the door and circulation planning. Having considered egress and accessibility in each step, the homeowners should have a general idea of how they intend for people to enter the space. In this step, the homeowner will determine the point of entry into each space. The IBC requires the ADU have two, distantly spaced, exterior entrances. As previously mentioned it, it also becomes important to consider the functionality of the doors and the furniture and fixtures surrounding the doorway. The designer needs to assure the operation of a door does not inhibit use in any way.

View/Vista

Option A: The primary door lies in clear view from the point of entrance to the property and the direction of approach (+1)

Option B: The primary door lies within view of point of approach (-1)

Accessibility/Egress

Option A: Layout creates a direct shortest path through spaces in the dwelling unit (+1)

Option B: The path is an indirect route (-1)

Total Scores

Option A: +2 (selected)

Option B: -2

LAYOUT REFINEMENT

(Step C.12 refer to Figure 7.1 and Figure 9.1 for complete workflow)

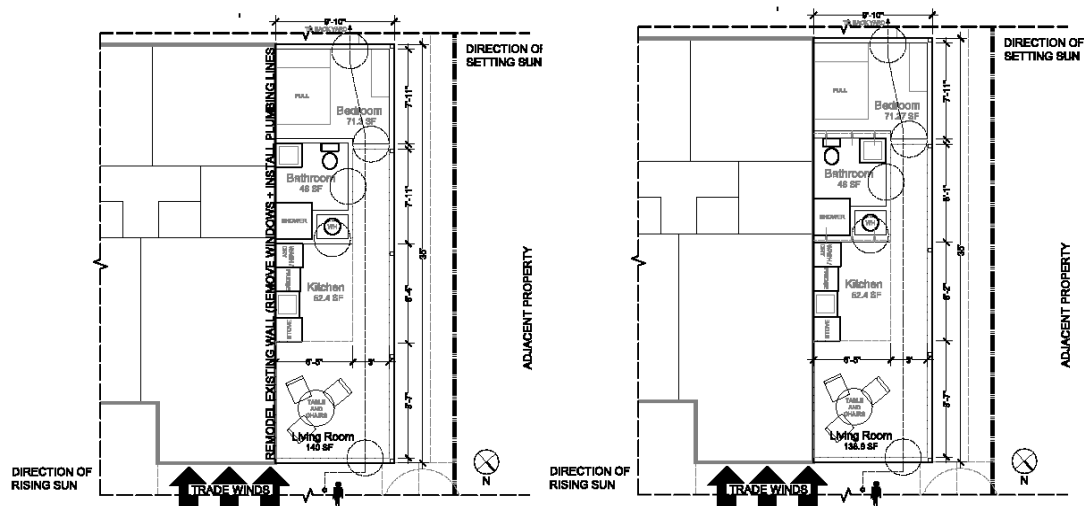

Figure 9.13 – Refinement steps made to the example Attached Modified ADU in response to the seven design lenses.

Having established the layout of the ADU, the homeowners may want to modify the layout to optimize the design. Before finalizing the layout, refine the design using the seven design lenses.

Accessibility/Egress

Regarding egress and accessibility, the modifications maintain the required clearances for components, and egress paths. Additionally, boundary lines for rooms are shifted to allow for a better allotment of space within the ADU. In the example, the egress path linking the living room to the bedroom must be kept to a minimum of 36 inches. The homeowner can use the accessibility/egress lens rules of thumb as a measure.

Structure

Walls near the bathroom and adjacent to plumbing fixtures host piping to provide water to the plumbing fixtures. The thickness of these walls are increased to accommodate the piping. The wall size increases from a five-inch generic wall to a seven-inch generic wall.

Cost

The floor area of the ADU was decreased to reduce the amount of built square footage. This was done to reduce the cost of the design.

WINDOW PLANNING

(Step C.13 refer to Figure 7.1 and Figure 9.1 for complete workflow)

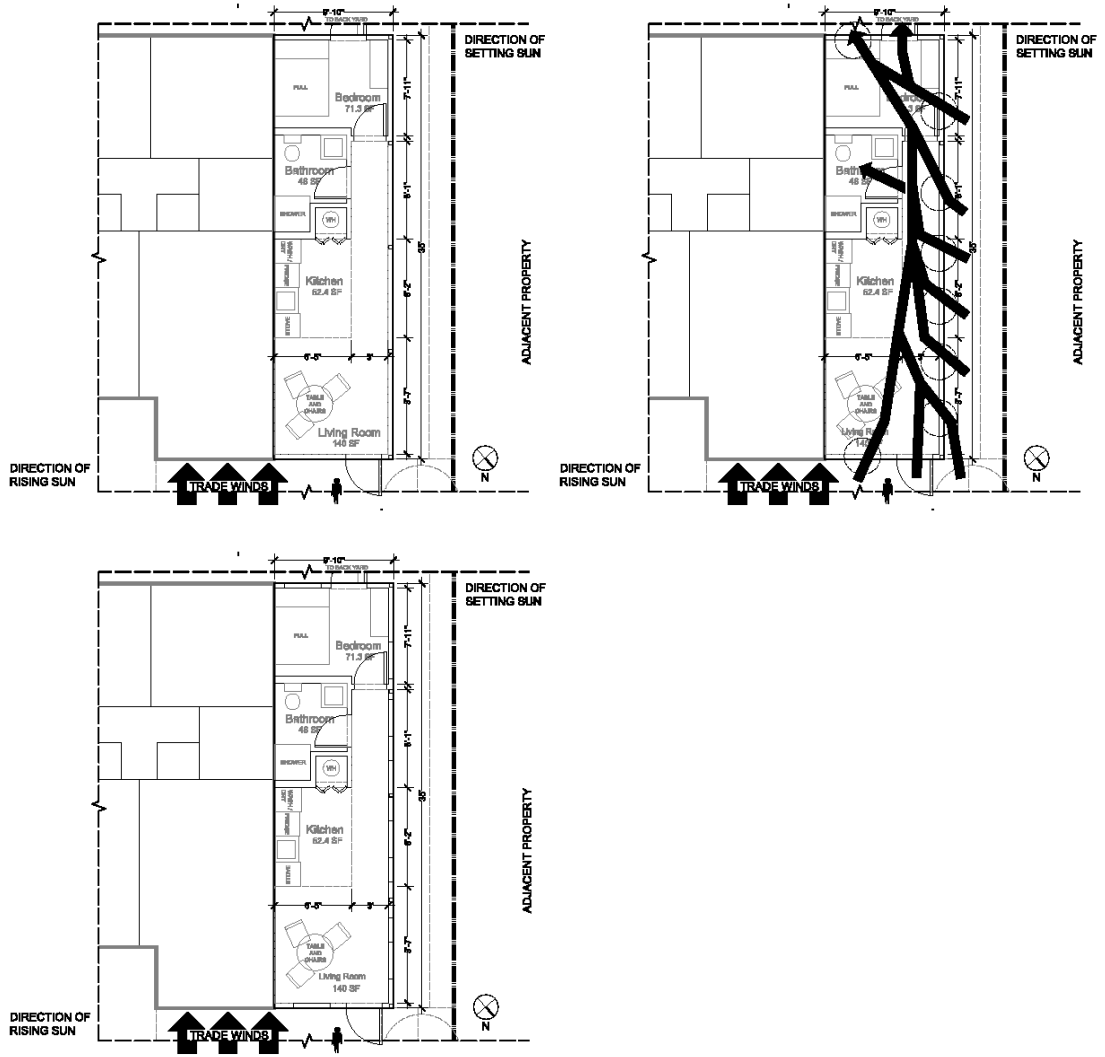

Figure 9.14– Design progression for the example Attached Modified ADU in consideration of window location and ventilation.

In this step, windows will be arranged to create passive ventilation and a cross wind throughout the design. The goal is to provide great views that functionally provide light and ventilation. The required open area on the exterior of the building must be four percent of the associated room floor area.²⁰² This regulation requires an operable window if pursuing passive ventilation. In the example, if the floor area of the room were

²⁰² Ibid.

100 square feet, then the window or door area required for that room would be four square feet. Referring to the lighting considerations, the glazed, or glass, the area must be eight percent of the floor area of a room.²⁰³

View/Vista

Views create a connection from the inside of the dwelling to the outside. Ideal views can frame objects of interest outside the ADU. In the example design, there are no decent views besides the back yard. The living room faces the garage and the wall at the property boundary. The kitchen and the bathroom have no outward facing views.

Accessibility/Egress

When laying out the windows for the ADU, the homeowner must consider fire exits. According to IRC 2006 section R310.1, all sleeping rooms require a fire exit. This exit is an operable opening that must be at a sill height of no greater than forty-four inches above the floor. Additionally, it must be at least twenty inches wide, twenty-four inches tall, and have an area of 5.7 square feet²⁰⁴.

In choosing locations for operable windows, one must consider the operation of the window. Windows should open outwards. Nothing outside the ADU should block the window from opening. The windows should also not face any tall object.

Ventilation

Cross ventilation is the best way to create air circulation throughout the inner space of the dwelling. Cross ventilation is a process of staggering openings in the design plan so that air must cross the space before leaving through another opening. Openings placed in line with each other create stale or inactive zones within the room because the air will not travel throughout the room and will exit through the least resistive path. The designer must consider the direction of the wind flow to the site when planning the placement of windows. As previously mentioned the primary wind direction is in the Northeast due to the trade winds. In the ventilation lens section it was identified that the primary wind direction in Hawai'i is the from the northeast where the trade winds blow from.

²⁰³ Ibid.

²⁰⁴ *International Residential Code*.

The bathroom spaces will need to be mechanically ventilated. There are off the shelf products that can ventilate the bathroom. Get a licensed professional to help with this product.

Structure

When considering the openness of the exterior wall, a balance should be formed where there is not too much surface area eaten away by exterior openings. The opaque areas contain the structure for the building, and if there is not enough structure in a wall, then it will fail to hold up the roof. It is possible to reduce the structural integrity of the wall by increase the glazing content of the wall. Windows require more efficient structural members than plain walls. Increasing structural efficiency may require thicker columns or use of a different material, such as steel. These measures will likely increase the cost of the building. These considerations can be investigated further with a licensed professional. The homeowner should simply understand that more windows may increase the cost of the ADU. Conceptually the homeowner can design the ADU to be constructed in wood and further modifications and material selections can be refined in conjunction with a licensed designer.

Privacy

As glazing creates a transparent or translucent portal to the exterior of the dwelling, the homeowner should assess the use of windows and their ability to create privacy. Windows in bathrooms should be placed up high to prevent unwanted lines of sight. Additionally, homeowners may wish to investigate security measures regarding the use of operable windows.

Cost

The assembly of a window unit is costly, so use of windows should be sparse and strategic.

Daylight

Lastly, the use of daylight should be strategically employed. Place windows in locations that minimize low sun angle glare. The low sun occurs in the evening and morning on the east and west sides of the building respectively. Minimizing openings on these faces of the building reduce unwanted light, Maximizing openings on the north and south faces

can help reduce the heat and improve visual comfort. In the example design, there is already an extended roof overhang, so excessive glare should not be an issue. The bedroom space is the only one susceptible to low evening sun angles.

ROOF SPAN ANALYSIS

(Step C.14 refer to Figure 7.1 and Figure 9.1 for complete workflow)

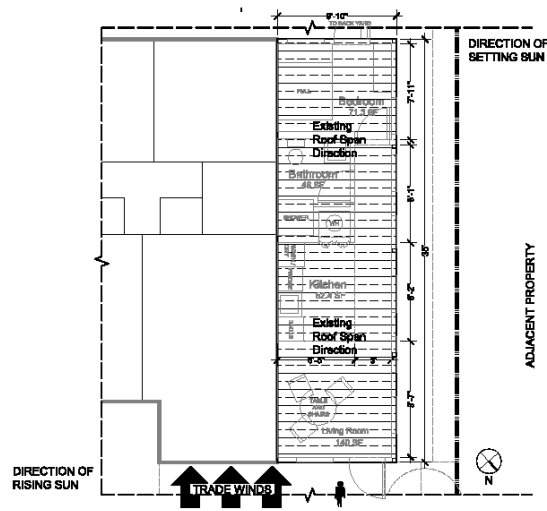

Figure 9.15– Roof span assessment in the design of the example Attached Modified ADU.

The next step is roof structure. As this prototype of ADU already makes use of an existing covered space, the structure has an established roof span. One can assess the roof structure by examining the house plans for the property.

BUILDING SECTION

(Step C.15 refer to Figure 7.1 and Figure 9.1 for complete workflow)

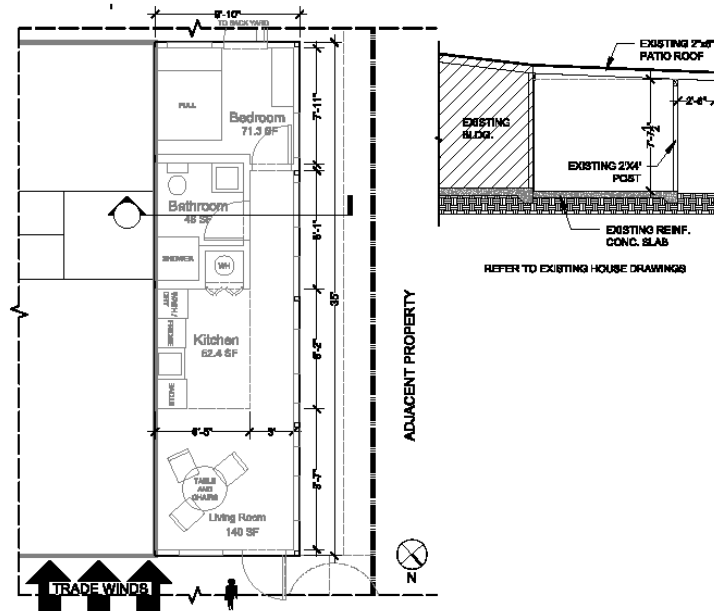

Figure 9.16 – Section drawing for the example ADU based upon the plan layout and existing building drawings.

A building section is a tool used by the construction industry to indicate what a building looks like if one were to cut the building at a specific location and look at it from that point of view. Imagine a fruit. If someone were to cut the fruit down the middle and take a picture perpendicular to the cut, the resulting image of the interior of the fruit would be a section view of the fruit. The design profession uses section views to gain insight into a design regarding heights and elevations that they cannot get from the plan view which this system has been using up until now.

This ASU Decision Support System will investigate one section of the building to get a general sense of the design. For a fuller understanding, additional sections will need to be made depicting varying aspects of the design. Cutting the single section can provide a general insight into the design that needs to further expansion upon by the homeowner or a licensed profession. The more the homeowner clarifies the design intent; the more successful the project will be.

In this type of ADU, there may already be a building section cut through the existing building. The homeowners can use this as a basis for drawing an update section view. From the plan, cut the section across the short direction. The section view will show the ground plane, the walls at their determined height and the existing roof structure. Refer to Figure 9.16 as an example.

SECTION REFINEMENT

(Step C.16 refer to Figure 7.1 and Figure 9.1 for complete workflow)

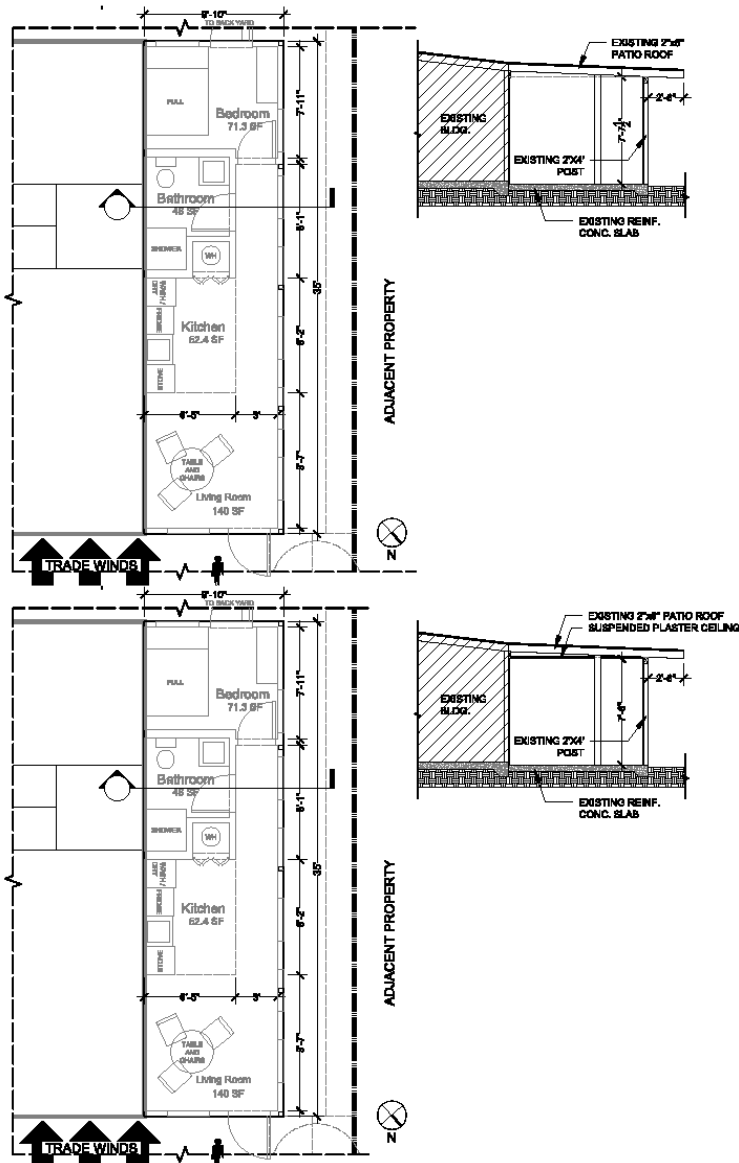

Figure 9.17– Refinement of the section drawing for example Attached Modified ADU to include the interior ceiling.

The section needs to be adjusted to depict the ceiling structure. As the attached modified type of ADU utilizes an existing roof, the underside of the roof needs modification to become an interior surface that can host lighting fixtures. When placing the ceiling in the section, it is important to consider the following.

According to IBC Section 1208.2, “[o]ccupiable spaces, habitable spaces and corridors shall have a ceiling height of not less than 7 feet 6 inches.”²⁰⁵

According to the Land Use Ordinance and the ADU development requirements, ADUs have a height limit of twenty-five feet.²⁰⁶

CONSTRUCTION SYSTEMS APPLICATION

(Step C.17 refer to Figure 7.1 and Figure 9.1 for complete workflow)

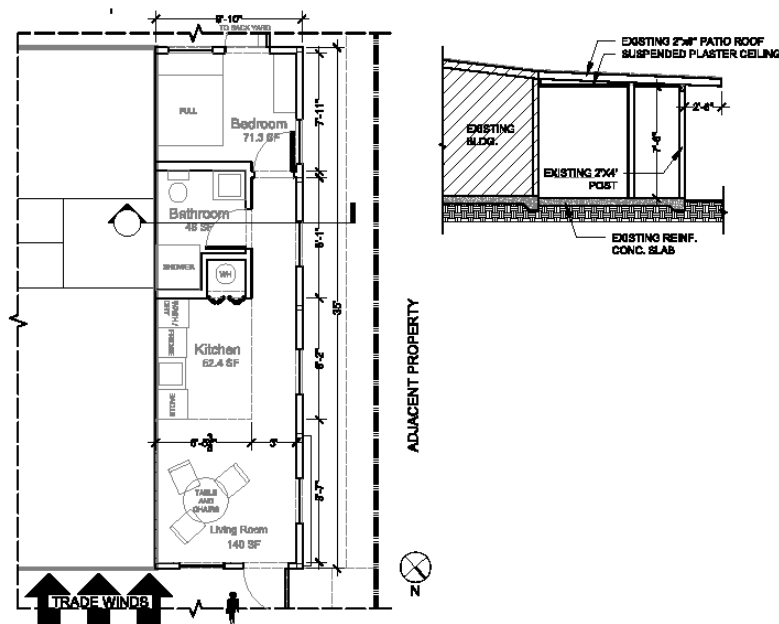

Figure 9.18– Final plan and section for the example Attached Modified ADU.

²⁰⁵ *International Building Code.*

²⁰⁶ Honolulu, "Chapter 21: Land Use Ordinance."

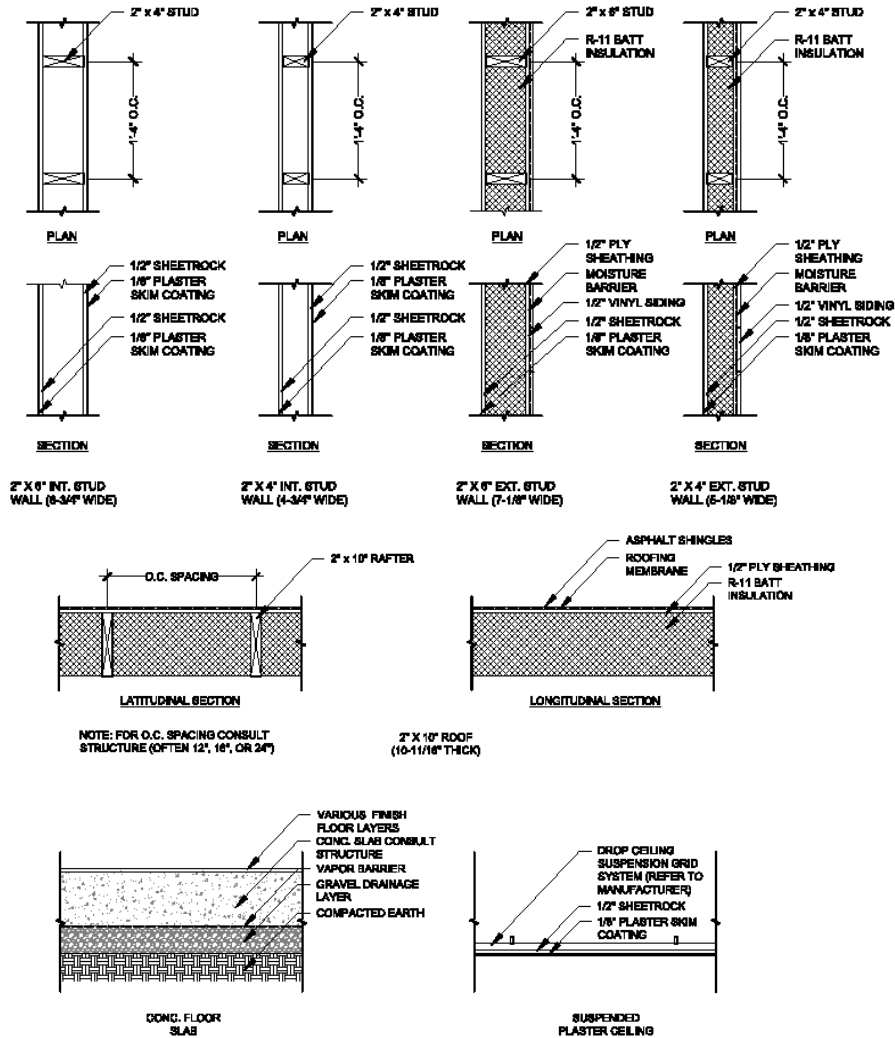

Figure 9.19– Basic construction details to be used as reference in the application of construction systems to the design of the Attached Modified ADU.

In the final design step, the homeowner applies real thicknesses to the generic wall and ceiling types used so far.

The example design features a low-cost construction assembly. The typical details in Figure 9.19 will form the basis of the construction assembly. Modifications can be made but the homeowner should Interior walls become interior partitions faced with two sides of gypsum board. Gypsum wallboard faces the exterior walls on the inside. Vinyl siding covers the exterior side of the wall. Remember that walls with plumbing lines will be thickened to use a six-inch stud while non-plumbing walls will use a four-inch stud. The floor construction consists of a finish floor layer on top of a poured in place reinforced concrete slab. The slab has a reinforced edge at the perimeter of the ADU. The roof

construction consists of wooden joists at the depth previously determined that is faced on the inside with a plaster finish and faced to the exterior with the various roofing layers. Typical details provided above. The use of these affordable construction assemblies will assist the homeowner in the cost analysis of the design.

CONCEPTUAL MATERIAL TAKEOFF

(Step C.18 refer to Figure 7.1 and Figure 9.1 for complete workflow)

The final step in the design for the Detached ADU is the material takeoff. In this step, basic sizes and dimensions are examined to determine the quantities of materials used by the design. In the cost analysis section, the homeowner attributes financial rates to the quantities determined in the material takeoff step. This step is essential in generating information about the design from which to assess the effectiveness of the ADU concept.

As previously explored, this study applied typical construction assemblies to the conceptual prototype. These assemblies are an aggregate of various construction materials. Homeowners can use the assemblies to estimate the cost of the ADU design. This cost is just an estimate. A precise cost is not necessary for the process of validating a design concept. Rather broad estimates based on the assemblies can be used in the material take off step. The quantities recorded will either be a basic count (each, ea.), an area quantity (square feet, sf.), or a quantity based upon a linear measurement (linear feet, lf.). The designers can use a multitude of other types of materials in the assembly granted they have a cost rate and an installation rate. This material takeoff establishing quantities used in conjunction with RSMeans Square Foot Costs 2010.

Table 9.5 - Table for homeowner to expand upon for the estimation of materials in the design

Subject	Type	Quantity	Units
Counter Top	Laminate		LF.
Cabinet	Vanity Cabinet		EA.
Ceiling	Gypsum on Wooden Support		SF.
Doors	Single-Flush		EA.
Floor	Laminate		SF.
Electrical	Fixtures per Total Built Area		SF.
Kitchen Sink	Double Bowl		EA.
Bathroom Layout	Full layout 3 Fixtures (Toilet, Sink, Shower)		EA.
Water Heater	Electric		EA.
Range/Stove	Built-in		EA.
Washing Machine	Stacked Automatic		EA.
Refrigerator	Economy		EA.
Roof	Asphalt-Shingle		SF.
Foundation	Cast-in-place Concrete		SF.
Slab Edge	Building Perimeter		LF.
Wall	Interior (5"/7") / Exterior (5"/7")		SF.
Windows	Louver		EA.

CHAPTER 10 : OTHER DESIGN CONSIDERATIONS

AESTHETIC CONSIDERATIONS

Having designed two ADU variations, the homeowner may have a stronger understanding of functional design considerations. However, design is not always functional and has an aesthetic, expressive, and elegant nature. This section will not cover a wide gambit of aesthetically driven design decisions as it is not the primary focus of this study. But, the study will provide some insight into how some of these considerations affect the overall cost in design.

WALL FORM CONSIDERED

When designing a space, a rectilinear layout is highly effective in creating a regular organizational framework. There are times, however, when a designer may exchange a rectilinear approach for employing an angular or curvilinear edge to a room. Site limitations may influence the exchange to a different layout approach, or simply to create a more visually interesting building. Nonetheless, curved and angled walls are also effective means of enclosing space but vary about cost. The owner should also note the cost analysis is not representative of true total costs and does not include the labor needed for this construction. Rather, the cost is conceptual and illustrative of correlations between design and material costs. The following examples explore curves and angles in the creation of a wood stud framed wall.



Figure 10.1– Diagram of three generic wood framed walls for the purpose of comparison.

Table 10.1 – Material cost comparison of three generic aesthetically different walls. Table refers to construction considerations of walls in Figure 10.1.

Material	Area	Cost	Est. Const. Cost
Default Wall			
1/2" gypsum wallboard		0.55/sf.	
1/16" plaster base coat		0.15/sf.	
1/16" plaster finish coat		0.12/sf.	
2" x 4" wood stud		0.59/lf.	
			total
Curved Wall			
1/4" gypsum wallboard (flexible)		0.55/sf.	
1/16" plaster base coat		0.15/sf.	
1/16" plaster finish coat		0.12/sf.	
1-1/8" plywood plate (curved)		1.83/sf	
2" x 4" wood stud		0.59/lf.	
			total
1/2" gypsum wallboard		0.55/sf.	
1/16" plaster base coat		0.15/sf.	
1/16" plaster finish coat		0.12/sf.	
2" x 4" wood stud		0.59/lf.	
			total

Source: Cost Data based on Homedepot.com online catalog (accessed: 1/15/17)

The generic straight wood framed wall is simple in construction. It starts off with a sill plate framed by either 2"x4" or 2"x6" lumber members at the base of the wall. Then 2-by members are fastened to the sill plates perpendicularly on end. At the other end vertical members, two top plates are fastened. In between vertical members, fire blocking is cut and fastened in accordance with the IRC section R602.8. Next, the wall assembly is tilted up into position and fastened to the floor. Sheathing plywood or sheetrock finally attached to the wood frame assembly.

Builders framing a curvilinear wall employ different methods from straight wall construction. The problem lies in the construction of the bottom and top plates. As there are no curved wooden stud contractors will have to employ other means. In an article, one contractor discussed the use of two layers of custom cut plywood to create the bottom plate. The example features the use of the plywood method. Additionally, there is a metal product that can be used to bend a curve sill plate. The construction of the wall portion might be constructed in place or tilted up as in the previous example. Next, the

sheathing needs to be flexible enough to cover the wall. Homeowners can use flexible sheetrock.

Lastly, the angled wall scenario also requires a slightly different method of construction. The angled wall construction is like the flat wall construction but frames a corner. The builder constructs two flat segments at the desired length then tilted into position. The corner requires mitered pieces of lumber to fasten the two segments together. Standard sheathing material can be employed but may also require mitering or a corner cover.

Figure 10.1 depicts the three wall conditions. Each wall is ten feet in length and ten feet in height. The analysis in Table 10.1 illustrates considerations for material construction of these walls. There are cost implications for aesthetic considerations. The curved wall is the most expensive because curving of the sheathing material studs may need to be spaced closer together to accomplish a smoother finish. Additionally, some materials may need to be substituted to facilitate the curve. The angled wall condition, however, is in the flat condition except for more framing material needed for the mitered corner. From this small analysis, the designer can see that the form of the wall does impact the cost of construction and should be considered by a designer or homeowner when creating a conceptual ADU plan.

EXTENSION OF SPACE CONSIDERED

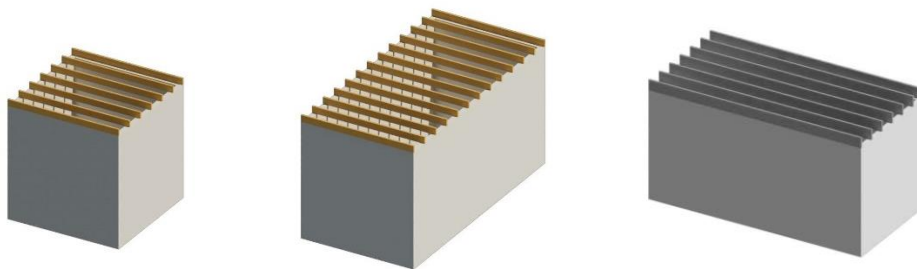

Figure 10.2 – Diagram depicts roof structures over three different volumes. The default box on the far left is an 8 ft. x 8ft. cube. The other two rectangular volumes are 16 ft. by 8 ft. volumes which differ in respect to the direction of the spanning roof members. Table 10.2 – Referring to Figure 10.2 this table illustrates conceptual cost implications of the roof spanning direction.

Material	Area	Cost	Est. Const. Cost
Default Space			
2" x 6" wood rafter 16" on center	64 sf.	\$2.18/sf.	\$139.52
			Base Cost
Latitudinal Expansion			
2" x 6" wood rafter 16" on center	128 sf.	\$2.18/sf.	\$279.04
			2x Cost
Longitudinal Expansion			
2" x 10" wood rafter 16" on center	128 sf.	\$2.89/sf.	\$369.92
			2.65x Cost
<hr/>			
Source: Cost Data from RSMeans 2010 Square Foot Costs.			
<hr/>			

In design, the roof span direction is important as it impacts the overhead roof structure and the cost of construction. When designing a space there may be options to extend a space to accommodate the fixtures, components, or egress paths previously investigated. Depending on the direction of the extension, the homeowner should consider how extending a room can impact cost. In Figure 10.2, there are two conditions. These conditions are evaluated based on cost per square foot information provided by RSMeans 2010 and span tables provided in Figure 6.3. This analysis is not an illustration of the true cost. Rather, like the previous exploration, it is more illustrative of cost to design correlations.

The first condition is an extension of space in the direction parallel to the span of the roof structure. By extending the room parallel to the roof span direction, the effective roof spanning distance does not change, and therefore only more roofing members are added. By doubling the width of the structure, we have effectively doubled the cost of the roof structure.

In the second condition, the extension of the space made in the in-line direction to the structure. In doing so, the effective roof spanning distance increases. The designer needs to substitute a more robust member for the spanning member. In doubling the distance, the cost of the roof structure went up 2.65 times rather than simply doubling.

When laying out space, the direction of roof span becomes important, and the designer should keep in mind throughout the process. The ADU Decision Support System addresses roof span near the end of the workflow. As the design is constantly changing, the designer can best establish roof span direction once the layout becomes closer to being finalized. However, being informed in the process while laying out the design, one can understand the correlation between space arrangement to structure and cost, which will allow the homeowners to make more informed decisions.

EXTERIOR MATERIAL CONSIDERED

The last of the aesthetic considerations is the role of material to cost. The homeowners may wish to create a unique ADU. They may wish to consider other types of material. While the homeowners may understand the correlation of cost to the material, they may not be aware of the ballpark range of the cost implications. Below table x itemizes some typical exterior building materials regarding their cost per square foot. These rates are from the baseline costs established in RSMeans 2010 without factoring in considerations of location and bringing the costs up to the current year. The purpose of this consideration is to illustrate the impact of material choice and construction cost.

Table 10.3 – Material cost rates for five common home exteriors. The table depicts the various costs to create a cost-design correlation or understanding.

Material	Material Cost.	Installation Cost.	Est. Const. Cost
Stone (economy)	\$12.05/sf.	\$19.85/sf.	\$31.90/sf.
Brick veneer	\$7.60/sf.	\$15.45/sf.	\$23.05/sf.
Wood siding	\$3.14/sf.	\$5.25/sf.	\$8.39/sf.
Plain vinyl siding	\$2.48/sf.	\$4.78/sf.	\$7.26/sf.
Cement Stucco	\$2.39/sf.	\$8.45/sf.	\$10.84/sf.

DESIGN FOR FUTURE ADUS

Expanding upon the present day ADUs, design presents an opportunity to prepare for future conditions or scenarios. Based upon the investigations found in the previous chapter regarding future conditions, a design for future ADUs may wish to consider independent wastewater systems, alternative transportation, renewable energy, and decentralized constructions. This chapter will investigate a means to incorporate future considerations into the decision support system workflow.

Figure 10.3 depicts the decision support system workflow which has been amended to incorporate for future conditions. The independent wastewater study gets incorporated at the early stages of workflow when determining if the site meets the requirements for an ADU. The alternative transportation study gets investigated in the space analysis just before the ADU type selection step. The incorporation of renewable energy comes into play just after establishing the roof span and size. The decentralized construction considerations become employed before applying generic construction systems to the design. Lastly, future expansions to the ADU Decision Support System can investigate in the step where homeowner or ADU designer engages a professional.

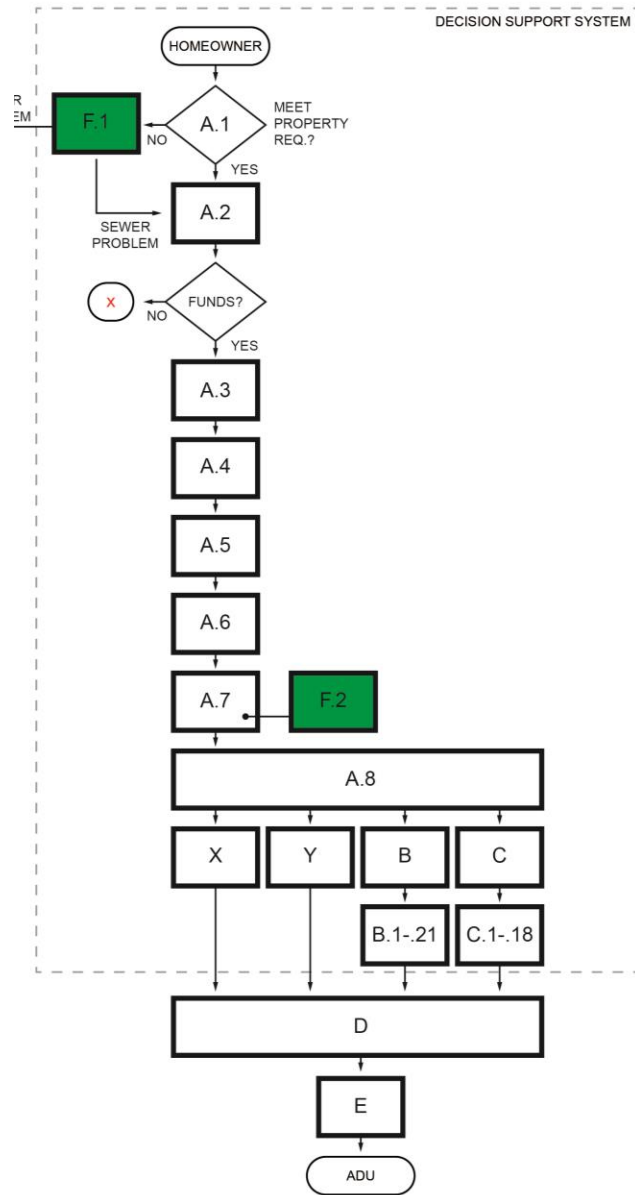

Figure 10.3– Overall Decision Support System design workflow incorporating future considerations discussed in Chapter 4. Refer to Table 7.1

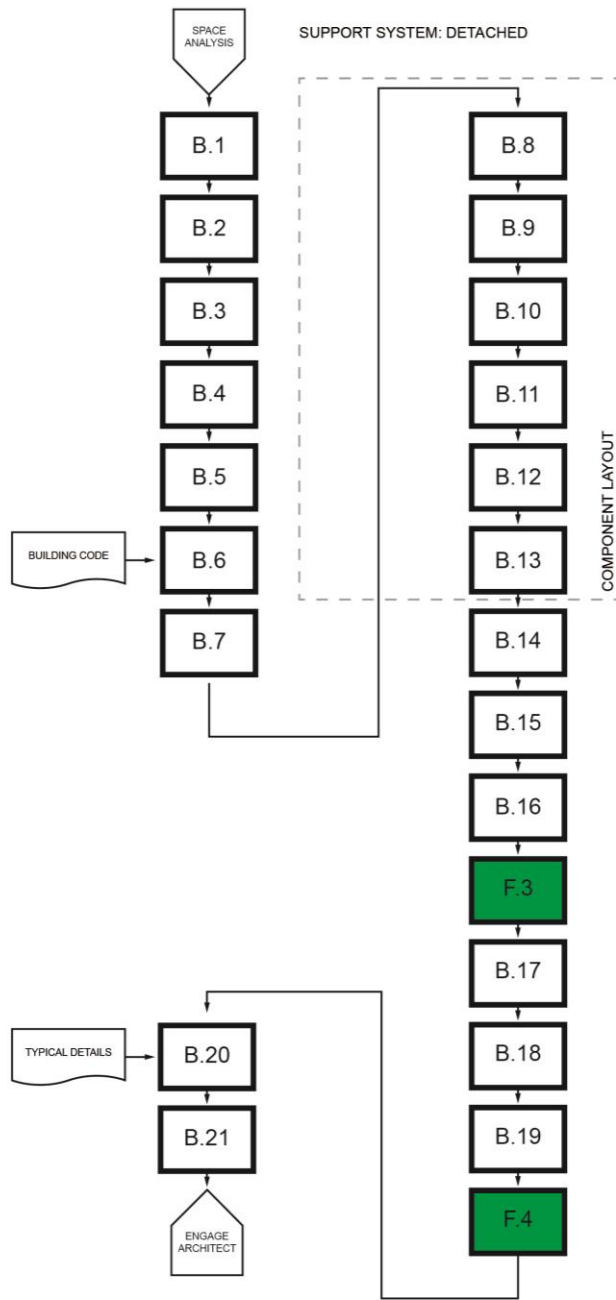

Figure 10.4– Design workflow for the Detached ADU incorporating future considerations discussed in Chapter 4. Refer to Table 8.1.

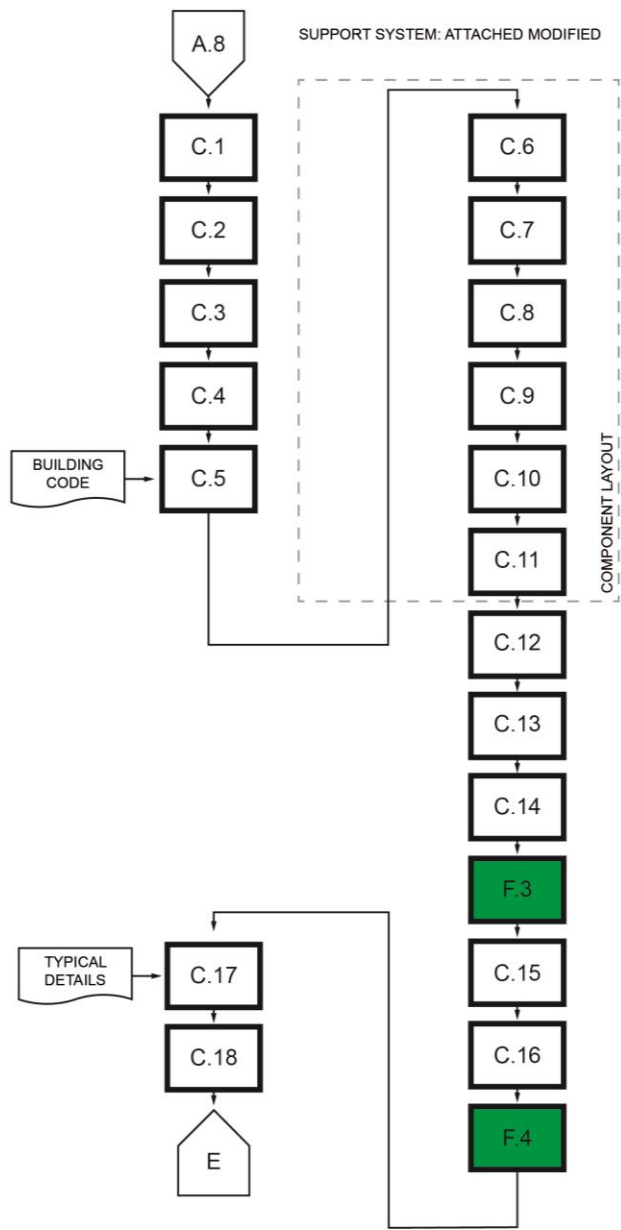

Figure 10.5– Design workflow for the Attached Modified ADU incorporating future considerations discussed in Chapter 4. Refer to Table 9.1

Table 10.4– Reference steps for future workflow expansions. Refer to Figure 10.3, Figure 10.4, and Figure 10.5.

F.1	Independent Wastewater Consideration
F.2	Alternative Transportation Considerations
F.3	Renewable Energy Considerations
F.4	Decentralized Construction Considerations

INDEPENDENT WASTEWATER CONSIDERATIONS

(Step F.1 refer to Figure 10.3)

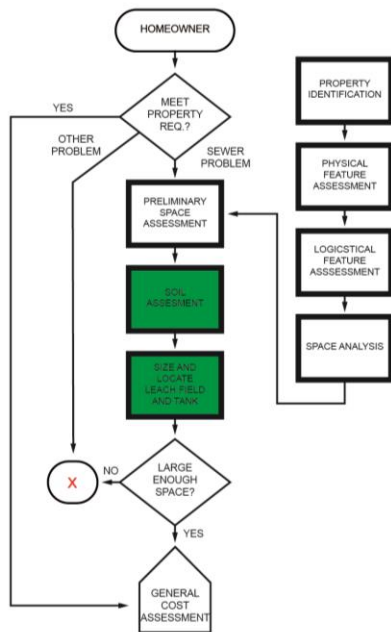

Figure 10.6 – Workflow depicting steps to consider alternative wastewater system implementation

In the chapter Future ADU issues, this research investigated how independent wastewater systems have the potential to remove blockades in the way of ADU development. A major obstacle in ADU development is the lack of public sewer capacity. By employing an independent system, ADUs can reduce the burden on the state public system while providing affordable housing supply.

The obstacle, however, is that independent systems can be potentially hazardous if not held to a high standard. The section investigated edits to the regulation to allow for innovation and exploration of more efficient and safe implementation of independent

Table 10.5 – Soil Types refer to map above

Septic Tank Absorption Fields— Summary by Map Unit — Island of Oahu, Hawaii (HI990)						
Map unit symbol	Map unit name	Rating	Component name (percent)	Rating reasons (numeric values)	Acres in AOI	Percent of AOI
AeE	Alaeloa silty clay, older substrate, 15 to 35 percent slopes, MLRA 167	Very limited	Alaeloa, older substrate (100%)	Slow water movement (1.00)	1,587.2	0.4%
				Slope (1.00)		
ALF	Alaeloa silty clay, 40 to 70 percent slopes	Very limited	Alaeloa (100%)	Slow water movement (1.00)	2,859.5	0.7%
				Slope (1.00)		
BS	Beaches	Very limited	Beaches (100%)	Flooding (1.00)	1,124.5	0.3%
				Depth to saturated zone (1.00)		
				Filtering capacity (1.00)		
				Seepage, bottom layer (1.00)		
CR	Coral outcrop	Not rated	Coral outcrop (85%)		10,921.2	2.8%

Figure 10.7 depicts a general soil map retrieved from the USDA interactive soil map.²⁰⁷

The example design site falls in a zone categorized as CR for coral outcrop. This soil rating shows the use of septic tank leach fields is not rated or not available for the specific location. The health concern is that coral is very porous, effluent will pass straight through the soil and into the surrounding watershed and coastal habitat. In Figure 3.1 the public sewer system was depicted for the island of Oahu, and it shows that the public system, after treatment, dumps waste liquid back into the ocean²⁰⁸. Can there be a possibility that innovations in independent wastewater treatment can get to a level of quality where it is safe to return waste to the site?

Sizing of Leach Field

The next step is the sizing of the area to be used as a leach field. A leach field takes up

²⁰⁷United States Department of Agriculture, "Area of Interest Map," <https://websoilsurvey.sc.egov.usda.gov/App/WebSoilSurvey.aspx>.

²⁰⁸

a certain amount of space on a property. The layout, orientation, and arrangement of the leach field need to be considered at an early stage in the site planning to assure that there is adequate space on the site. Currently, the Hawaii Administrative Rules has outlined sizing requirements for leach fields. The figure below depicts the table. In a future scenario where treatment technology has improved the sizing of the leach field may become smaller.

CHAPTER 11-62 APPENDIX D - TABLES

TABLE III
July 1, 2014

Percolation Rate (min/inch) Less than or equal to	Required Absorption Area (ft ² /bedroom or 200 gallons)	Percolation Rate (min/inch) Less than or equal to	Required Absorption Area (ft ² /bedroom or 200 gallons)
1	70	31	253
2	85	32	257
3	100	33	260
4	115	34	263
5	125	35	267
6	133	36	270
7	141	37	273
8	149	38	277
9	157	39	280
10	165	40	283
11	170	41	287
12	175	42	290
13	180	43	293
14	185	44	297
15	190	45	300
16	194	46	302
17	198	47	304
18	202	48	306
19	206	49	308
20	210	50	310
21	214	51	312
22	218	52	314
23	222	53	316
24	226	54	318
25	230	55	320
26	234	56	322
27	238	57	324
28	242	58	326
29	246	59	328
30	250	60	330

Figure 10.8 - Sizing of Septic Leach Field Table²⁰⁹

²⁰⁹ "Wastewater Systems."

ALTERNATIVE TRANSPORTATION CONSIDERATIONS

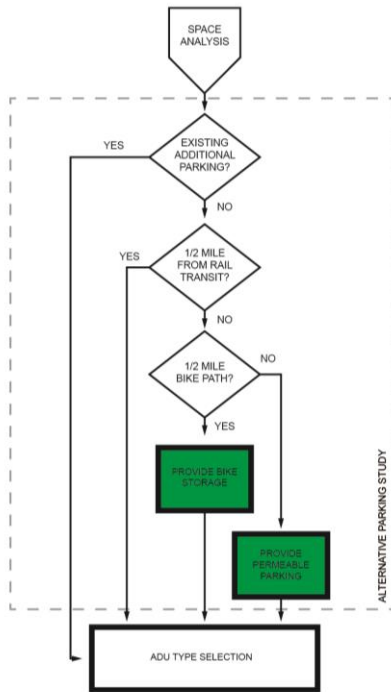

Figure 10.9 – Workflow depicting steps needed to incorporate alternative transportation considerations.

In the Future ADU Issues chapter, this study investigated alternative transportation. The future scenarios addressed are the Transit Oriented Development and city planning. Communities will feature more amenities within walkable and bikeable distances. Additionally, city planning may be able to provide the necessary infrastructure to accommodate alternative transportation methods by providing bike-friendly routes to and from key locations in the neighborhood. Lastly, the dependence upon the personal automobile may decrease with the emergence of communal car systems such as car share and ride share. This section provides an amendment to the Decisions Support System to integrate alternative transportation considerations.

Bike Path Assessment

The first step in this section is to assess the community environment to see if there are any nearby bike transportation networks. The State Department of Transportation has a collection of bike route maps as they grow in conjunction with the Honolulu Bike

RENEWABLE ENERGY CONSIDERATIONS

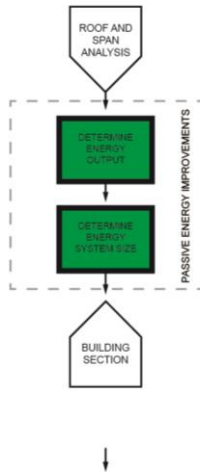

Figure 10.11 – Workflow depicting renewable energy considerations.

Determine Energy Demand

The homeowner pursuing the ADU must first consider how much energy is needed to offset the energy used by the new ADU. The owners can evaluate their energy bill and make a guess at what may be an appropriate usage estimate. Based on data from the U.S. Energy Information Administration (EIA) the average Hawaii home consumes 6168-kilowatt hours per year which is equivalent to 514-kilowatt hours per month (kWh).

Size Energy System

With a basic understanding of the energy needs of the system, the homeowner must determine the size of the PV array. A solar panel produces about 30 kWh per month. See Figure 10.12. The label claims that the panel can generate 250 watts.

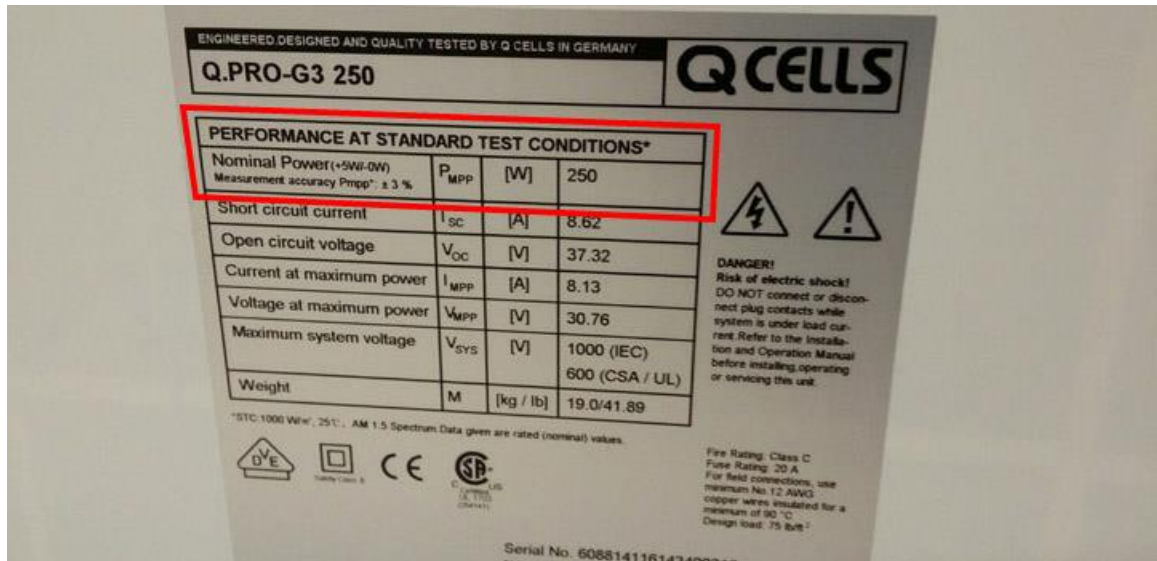

Figure 10.12 - Image depicting the energy use of a standard solar panel²¹¹

$250 \text{ watts} * 5.5 \text{ effective sun hours per day} * 30 \text{ days} * 0.86 \text{ (14\% efficiency)} = 32.2 \text{ kWh}$

When dividing the demand of 514 kWh per month by the output of one panel, 30 kWh, the owners can estimate the number of panels needed on the roof. PV panels are typically 3 feet by 5 feet, 15 square feet. An ADU employing a PV array to offset the average energy usage would need 17.1 panels which would take up 270 square feet of roof space.

²¹¹ Ben Zientara, "How Much Electricity Does a Solar Panel Produce," <https://solarpowerrocks.com/solar-basics/how-much-electricity-does-a-solar-panel-produce/>.

DECENTRALIZED CONSTRUCTION CONSIDERATIONS

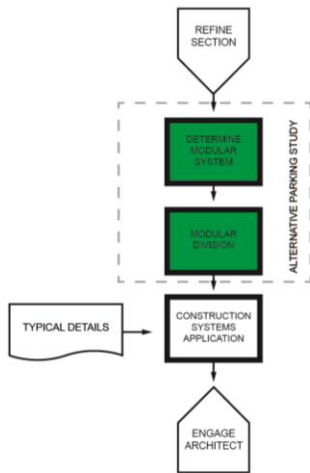

Figure 10.13 – Workflow depicting decentralized construction considerations

The last of the future considerations is the use of decentralized construction. With the popularity and efficiency found in prefab and precast technologies, off-site methods may soon become viable alternatives to on-site construction. As mentioned earlier the rise of 3D printing for large scale production of buildings and the emergence of a maker movement suggests a future scenario where individual homeowners may be empowered to assemble and construct their ADU. The homeowner led ADU development and construction may allow for a wave of new ADU construction with few barriers to creating affordable housing in the City and County of Honolulu.

In the future, the ADU Decision Support System could incorporate a modularization step into the design process just before the construction systems application step. In the modularization step, the design would be adjusted to fit on a modular division grid and then subdivided into sizable chunks. A certified modular manufacturer or the end user could manufacture the chunks employing a standardized modular system. This study begins contemplating such a system below. Through this system, the informed individual can generate a desirable ADU design using this support system. The homeowner is empowered to use the modular construction system to build the ADU themselves or with the assistance of a certified modular assembler. The ease of construction would come in where the homeowner can generate the modular chunks by 3D printing them at a nearby maker space. This process removes as many roadblocks

as possible between the desire for more affordable housing and the homeowner led the development of housing. The role of design and construction would be in generating fool-proof systems that assure a standard of quality of designs that come out of the use of the modular system.

The modular system explored here employs a planar modular system that relies on the strength and stability of 3D printed material a structural frame. The planar elements must have a wide range of varieties that allow for diverse reconfigurations. Figure 10.14 – Variations of design explored through planar modular elements depicts a few design variations possible using this system. Figure 10.15 depicts the individual chunks that form the modular system library. These parts include window units, door units, and solid units. Additionally, the roof is segmented as well so strength in the 3D printed material must be able to overcome bending forces at joints to ensure that the roof structure behaves closer to a beam than a string of beads. The specific design considerations regarding the modular system need to be further explored but are beyond the scope of this research. The possibilities to leverage homeowner led design and construction through the decentralized construction of ADUs has a great potential to serve the State in its fight to produce housing. The issue lies in equipping the homeowner with predefined yet flexible systems without lowering the standard of care and safety.

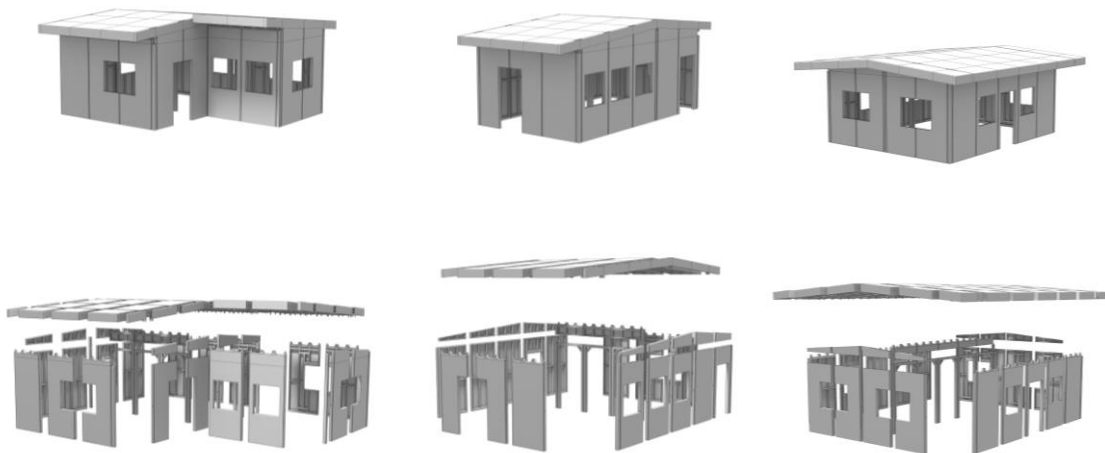























Figure 10.14 – Variations of design explored through planar modular elements

	SUPPORT WALL	SPLIT DOOR WALL	SPLIT WINDOW WALL	DOOR WALL	WINDOW WALL	DEFAULT WALL
6" REDUCED						
1" REDUCED						
INTERMEDIATE WALL						
DEFAULT 4' MODULE						





































ROOF CHUNK OVER 4" COLUMN	ROOF CHUNK OVER 6" COLUMN	ROOF CHUNK	ROOF CHUNK 1" REDUCED	EDGE EXTENSION	ANGLED WALL EXTENSION	WALL EXTENSION	COLUMN CONNECTOR
							
							
							
							
							

Figure 10.15 - A planar modular system that can adapt to the needs of a design

CHAPTER 11 : DESIGN ANALYSIS

The intent of this research is to empower and equip Hawai'i homeowners with the ability to generate a conceptual ADU scheme with the assistance of an ADU Decision Support System. This support system promotes a design path to get from intent to preliminary production design. The ADU Decision Support System encourages homeowners to research options towards the construction of an ADU before financially committing to the process. Through the process of creating a preliminary production design, The ADU Decision Support System educates the homeowners on the design and budget planning required to construct and ADU in the homeowners' spare time and without financial obligation. The information gained through the ADU Decision Support System allows homeowners clearly decide whether to pursue ADU construction. The process also prepares the homeowner for communicating with licensed professionals like architects

and contractors saving the homeowner time and money.

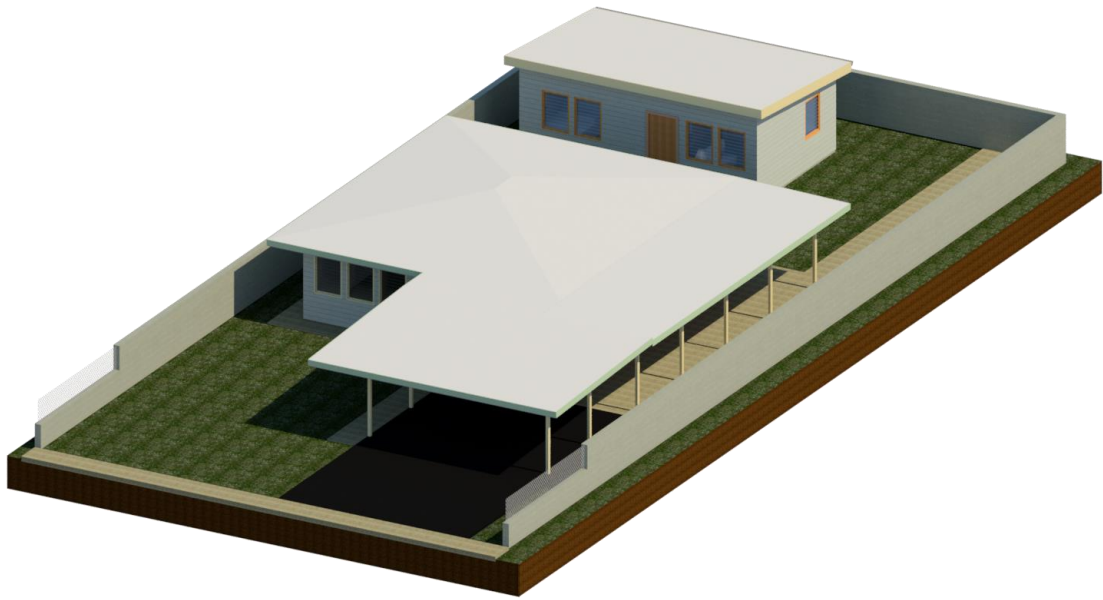

Figure 11.1 - Final detached example design in relation to the existing site

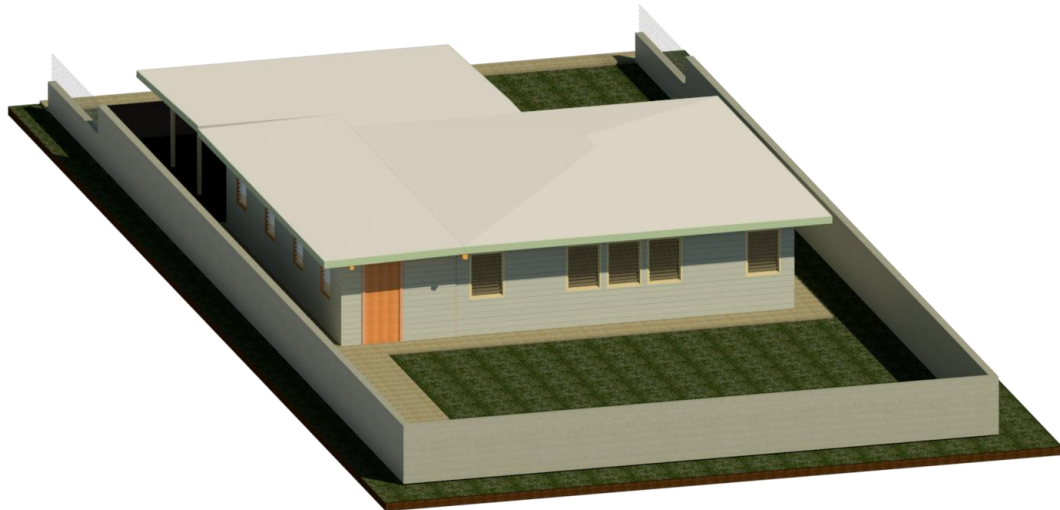

Figure 11.2 - Final attached modified example design in relation to the existing site

DETACHED ADU COST ANALYSIS

Table 11.1 – Cost analysis of example detached design

ADU Prototype Material Cost Estimate		Type: Detached					
Family	Type/Material	Units/Area/Vol	Unit Cost	Installation	Const. Cost		
Casework Schedule							
Counter Top		117.00 LF	\$9.10	\$11.10		\$2,363.40	
Vanity Cabinet	Double Door Sink Unit: 30"	1.00	\$305.00 EA	\$31.00		\$336.00	
Vanity Cabinet	Double Door Sink Unit: 36"	1.00	\$345.00 EA	\$33.00		\$378.00	
Base Cabinet	Single Door & Drawer: 18"	3.00	\$259.00 EA	\$28.50		\$862.50	
						Subtotal:	\$3,939.90
Ceiling							
Plaster Drop Ceiling	2 coat gyp. Painted on Wooden Support	68.00 SF	\$1.48 /SF	\$5.10 /SF		\$447.44	
						Subtotal:	\$447.44
Door Schedule							
Single-Flush	36" x 84"	2.00	\$315.00 EA	\$183.00 EA		\$996.00	
Sliding Pocket Door (Sub Single-Flush)	32" x84" Sliding Pocket Door (Sub Hinged)	2.00	\$315.00 EA	\$183.00 EA		\$630.00	
						Subtotal:	\$1,626.00
Floor Material Takeoff							
Laminate Flooring	Wood Vinyl	277.00 SF	\$3.30 /SF	\$0.92 /SF		\$1,168.94	
Tile Flooring	Tile	69.00 SF	\$4.96 /SF	\$4.51 /SF		\$653.43	
						Subtotal:	\$1,822.37
Lighting and Electrical							
Receptacles and Wiring	5 per 1000 SF	344.00 SF	\$0.55 /SF	\$1.80 /SF		\$808.40	
Fluorescent Fixtures T-12	5 Fixtures @ 40	344.00 SF	\$0.81 /SF	\$1.72 /SF		\$870.32	
Lighting and Branch Wiring	5 per 1000 SF	344.00 SF	\$0.26 /SF	\$0.91 /SF		\$402.48	
						Subtotal:	\$1,678.72
Plumbing Fixtures							
Kitchen Sink	32" x 21" Double Bowl	1.00	\$745.00 EA	\$785.00 EA		\$1,530.00	
Bathroom Layout	3 Fixture, Two Wall (W.C., Lav, Shower)	1.00	\$3,075.00 EA	\$2,450.00 EA		\$5,525.00	
						Subtotal:	\$7,055.00
Equipment							
Water Heater	Electric, 30 Gallon	1.00	\$520.00 EA	\$162.00		\$682.00	
Range	Built-in	1.00	\$750.00 EA	\$97.00		\$847.00	
Washing Machine	Automatic	1.00	\$1,125.00 EA	\$625.00		\$1,750.00	
Refrigerator	Economy	1.00	\$490.00 EA	\$81.50		\$571.50	
						Subtotal:	\$3,850.50

Roofing						
Single Ply Membrane	EPDM	485.00 SF	\$1.14	\$0.90		\$989.40
Asphalt Roofing	Strip Shingles	485.00 SF	\$0.87	\$1.00		\$906.95
Insulation	2" Rigid Insulation	348.00	\$1.08	\$0.51		\$553.32
2" x 10" Rafter	16" O.C.	485.00 SF	\$1.27 /Sf	\$1.62		\$1,401.65
Gutter	Box, Aluminum	62.70	\$2.68	\$4.96		\$479.03
Downspout	Rectangular, Aluminum	8.00 LF	\$1.14	\$3.13		\$34.16
Roof Flashing	Aluminum	90.58 LF	\$1.12	\$3.25		\$395.83
Subtotal:						\$4,760.34
Foundation						
Slab Edge	24" x 12" Cast-in-place, Reinforced	81.92 LF	\$14.00 /Lf	\$21.00		\$2,867.20
Slab	6" Cast-in-Place, Reinforced	393.00 SF	\$2.86 /Sf	\$2.93		\$2,275.47
Subtotal:						\$5,142.67
Walls						
Exterior Stud Wall 5"	2" x 4" Plain Vinyl Siding, 16" O.C. Insul. Wall	366.00 SF	\$2.48 /Sf	\$4.78		\$2,657.16
Exterior Stud Wall 5"	1/2" Interior Drywall	366.00 SF	\$0.31 /Sf	\$0.51		\$300.12
Exterior Stud Wall 7"	2" x 6" Plain Vinyl Siding, 16" O.C. Insul. Wall	180.00 SF	\$2.90 /Sf	\$4.93		\$1,409.40
Exterior Stud Wall 7"	1/2" Interior Drywall	180.00 SF	\$0.31 /Sf	\$0.51		\$147.60
Interior Stud Wall 5"	2" x 4" Wood Studs, 16" O.C. with blocking	177.00 SF	\$0.29 /Sf	\$1.03		\$233.64
Interior Stud Wall 5"	1/2" Interior Drywall (2 sides)	354.00 SF	\$0.31 /Sf	\$0.51		\$290.28
Interior Stud Wall 7"	2" x 6" Wood Studs, 16" O.C. with blocking	58.00 SF	\$0.44 /Sf	\$1.14		\$91.64
Interior Stud Wall 7"	1/2" Interior Drywall (2 sides)	116.00 SF	\$0.31 /Sf	\$0.51		\$95.12
Subtotal:						\$5,224.96
Window Schedule						
Louver Window (Sub Wood Double Hung)	36" x 48" (Sub 32" x 54")	7.00	\$237.00 EA	\$224.00		\$3,227.00
Louver Window (Sub Wood Casement)	24" x 36" (Sub 22" x 38")	2.00	\$320.00 EA	\$147.00		\$934.00
Fixed Window (Sub Wood Awning)	31" x 24" (Sub 34" x 21")	1.00	\$223.00 EA	\$112.00		\$335.00
Subtotal:						\$4,496.00
Base Subtotal:						\$40,043.90
Location Factor (Honolulu):						1.21
Time Escalation^A:						1.12
Total Material Cost:						\$54,447.05
* Estimate not including labor and time						Total Area Built (SF): 344.00
* Estimate not including contingency						
* Estimate not including overhead and profit						Material Cost Per Sq. Ft. \$158.28
* Unit prices are for conceptual representation and not representative of real cost (costs refferance RSMeans 2010)						
^A RS Means Historical Cost Index (2010 - 2015)						

The final step in the design workflow for the detached ADU is the conceptual material take-off. This step itemized square footage of wall assemblies, roof assemblies, window assemblies, etc. By multiplying the areas derived in that step by depictive RSMeans cost rates, we can see how specific design areas impact the cost of design. Based on 2010 estimates, the costs are multiplied by a factors to acquire present day Hawaii costs. These estimates are illustrative for conceptual purposes and do not represent true costs.

In the example, the design for a detached ADU results in a construction cost of \$54,000. This cost is synonymous to \$157 per square foot. The breakdown shows the largest cost areas are plumbing fixtures, new building foundations, and windows. In fact, the windows cost almost equaled the cost of the building foundations. Based on RSMeans assembly costs, the material cost of the window matched the cost of installation. Support for the windows are sets of framing and trims that address issues of water infiltration around the openings. This level of detail raises costs. The materials used in this design were cost effective assemblies. ADUs are incorporating any significant design considerations as changes in finishes, medium to high-end fixtures, non-economy cabinetry, etc. the costs will be significantly greater.

This detached prototype does not feature any future design considerations which would add to costs. PV systems are expensive. Also, the cost breakdown did not consider grading and soil movement. The site work to install and the infrastructure to support a septic tank would significantly increase costs.

ATTACHED MODIFIED COST ANALYSIS

Table 11.2 – Cost analysis of example attached design

ADU Prototype Material Cost Estimate		Type: Detached						
Family	Type/Material	Units/Area/Vol	Unit Cost	Installation				Const. Cost
Casework Schedule								
Vanity Cabinet	Double Door Sink Unit: 30"	1.00	\$305.00 EA	\$31.00				\$336.00
Vanity Cabinet	Double Door Sink Unit: 36"	1.00	\$345.00 EA	\$33.00				\$378.00
Subtotal:								\$714.00
Ceiling								
Plaster Drop Ceiling	2 coat gyp. Painted on Wooden Support	308 SF	\$1.48 /SF	\$5.10 /SF				\$2,026.64
Subtotal:								\$2,026.64
Door Schedule								
Single-Flush	36" x 84"	2.00	\$315.00 EA	\$183.00 EA				\$996.00
Single-Flush	32" x 80" (Sub 36" x 84")	3.00	\$315.00 EA	\$183.00 EA				\$945.00
Subtotal:								\$1,941.00
Floor Material Takeoff								
Laminate Flooring	Wood Vinyl	273.00 SF	\$3.30 /SF	\$0.92 /SF				\$1,152.06
Tile Flooring	Tile	29.00 SF	\$4.96 /SF	\$4.51 /SF				\$274.63
Subtotal:								\$1,426.69
Lighting and Electrical								
Receptacles and Wiring	5 per 1000 SF	311.00 SF	\$0.55 /SF	\$1.80 /SF				\$730.85
Fluorescent Fixtures T-12	5 Fixtures @ 40	311.00 SF	\$0.81 /SF	\$1.72 /SF				\$786.83
Lighting and Branch Wiring	5 per 1000 SF	311.00 SF	\$0.26 /SF	\$0.91 /SF				\$363.87
Subtotal:								\$1,517.68
Plumbing Fixtures								
Kitchen Sink	24" X 21" Single Bowl	1.00	\$580.00 EA	\$725.00 EA				\$1,305.00
Bathroom Layout	3 Fixture, Two Wall (W.C., Lav, Shower)	1.00	\$3,075.00 EA	\$2,450.00 EA				\$5,525.00
Subtotal:								\$6,830.00
Equipment								
Water Heater	Electric, 30 Gallon	1.00	\$520.00 EA	\$162.00				\$682.00
Range	Built-in	1.00	\$750.00 EA	\$97.00				\$847.00
Washing Machine	Automatic	1.00	\$1,125.00 EA	\$625.00				\$1,750.00
Refrigerator	Economy	1.00	\$490.00 EA	\$81.50				\$571.50
Subtotal:								\$3,850.50
Roofing								
Insulation	2" Rigid Insulation	324.00	\$1.08	\$0.51				\$515.16
Subtotal:								\$515.16

Foundation						
Slab Edge	24" x 12" Cast-in-place, Reinforced	2.79 LF	\$14.00 /LF	\$21.00		\$97.65
Slab	6" Cast-in-Place, Reinforced	79.00 SF	\$2.86 /SF	\$2.93		\$457.41
Subtotal:						\$555.06
Walls						
Exterior Stud Wall 5"	2" x 4" Plain Vinyl Siding, 16" O.C. Insul. Wall	321.00 SF	\$2.48 /SF	\$4.78		\$2,330.46
Exterior Stud Wall 5"	1/2" Interior Drywall	321.00 SF	\$0.31 /SF	\$0.51		\$263.22
Interior Stud Wall 5"	2" x 4" Wood Studs, 16" O.C. with blocking	67.00 SF	\$0.29 /SF	\$1.03		\$88.44
Interior Stud Wall 5"	1/2" Interior Drywall (2 sides)	134.00 SF	\$0.31 /SF	\$0.51		\$109.88
Interior Stud Wall 7"	2" x 6" Wood Studs, 16" O.C. with blocking	381.00 SF	\$0.44 /SF	\$1.14		\$601.98
Interior Stud Wall 7"	1/2" Interior Drywall (2 sides)	762.00 SF	\$0.31 /SF	\$0.51		\$624.84
Subtotal:						\$4,018.82
Window Schedule						
Louver Window (Sub Wood Double Hung)	36" x 48" (Sub 32" x 54")	5.00	\$237.00 EA	\$224.00		\$2,305.00
Subtotal:						\$2,305.00
Base Subtotal:						\$25,700.55
Location Factor (Honolulu):						1.21
Time Escalation ¹ :						1.12
Total Material Cost:						\$34,944.62
* Estimate not including labor and time						Total Area Built (SF): 311.00
* Estimate not including contingency						
* Estimate not including overhead and profit						Material Cost Per Sq. Ft. \$112.36
* Unit prices are for conceptual representation and not representative of real cost (costs refferance RSMeans 2010)						
¹ RS Means Historical Cost Index (2010 - 2015)						

The design for the Attached Modified ADU also provided a material take off. The breakdown of materials is essential in generating useful decision making information regarding the design of the ADU itself. The total estimated cost for this variant of ADU in the example site is \$34,000. Like the above design, rates used in this estimate were the RSMeans 2010 assemblies cost. The cost per square foot for this model is estimated to be \$112. The costs for this type of ADU are less than the detached unit.

The primary contributors to cost are the plumbing fixtures and general equipment in the design. The other costs are relatively insignificant. The lowest cost contributor in the design is roofing and foundation, as this design reused both the roof and the floor slab.

Like the detached design, the cost estimate represents a minimal approach to design and material use. There are no future design considerations featured in this cost breakdown. Any significant design items such as a PV array or luxurious interior and exterior finishes would have significantly increased the cost of this prototype.

COST COMPARISON

When comparing the two cost breakdowns, evidence illustrates how aspects of the design influence cost. Through these realizations, homeowners learning about design make strategic modifications to their plans as to fit within their financial constraints. One realization is that the plumbing fixtures are an expensive component in the design of an ADU. The costs depicted were on the low end of the estimate as the in-wall piping was not included in the breakdown because estimating piping is difficult without a clear understanding of where the utilities are and what the sizing requirements would be needed based on the water point-of-connection.

Another realization is that countertop, even if they are laminate, are expensive. The counter top in the detached design made up most of the category. The base cabinets are costly in material, but installation is significantly less.

FULL COSTS IN ADU DEVELOPMENT

Table 11.3 – Analysis of both example designs in relation to total costs of the project²¹²

	Prelim Inclusions:	87.30%		Prelim Cost:	\$ 54,267.00		Prelim Cost:	\$ 34,944.00
Construction Cost Breakdown	Share of Const. Cost			ADU Detached	Estimated Cost		ADU Attached	Estimated Cost
Site Work & Logistics		5.60%			\$ 3,481.04			\$ 2,241.54
Foundations		11.60%			-			-
Framing		18.00%			-			-
Exterior Finishes		15.00%			-			-
Major Systems Rough-ins		13.10%			-			-
Interior Finishes		29.60%			-			-
Final Steps		6.80%			\$ 4,226.98			\$ 2,721.87
Other		0.50%			\$ 310.81			\$ 200.14
		100.20%			\$ 62,161.51			\$ 40,027.49
Site Work & Logistics	5.50%	100.00%			\$ 3,481.04			\$ 2,241.54
Permit Fees	1.20%	21.82%			\$ 759.50			\$ 489.06
Impact Fee	0.60%	10.91%			\$ 379.75			\$ 244.53
Water and Sewer Inspection Fee	1.40%	25.45%			\$ 886.08			\$ 570.57
Architecture and Engineering	1.60%	29.09%			\$ 1,012.67			\$ 652.08
Other	0.70%	12.73%			\$ 443.04			\$ 285.29
Final Steps	6.80%	100.00%			\$ 4,226.98			\$ 2,721.87
Landscaping	2.10%	30.88%			\$ 1,305.38			\$ 840.57
Outdoor Structures	1.50%	22.06%			\$ 932.42			\$ 600.41
Driveway	2.20%	32.35%			\$ 1,367.55			\$ 880.60
Clean Up	0.70%	10.29%			\$ 435.13			\$ 280.19
Other	0.30%	4.41%			\$ 186.48			\$ 120.08

Source: Data adapted from NAHB Single Family House Costs 2015

As previously mentioned in the general cost assessment section, there are other costs involved in the development of the ADU. Figure 7.2 depicted a breakdown of costs based on nation surveys which itemized costs based on the share of total cost. The breakdown based on a single-family home construction. To hopefully gain a more holistic view on cost Table 9 expands upon the ADU cost estimates in its relation to share of total cost of construction. The method employed is not a very accurate way to calculate cost as there are many other factors to consider but it will paint a larger representation of how the estimate provided per the ADU prototypes relate in a larger scheme of total development costs.

The development costs increase as permit fees, impact fees, inspection fees, architecture and engineering fees, additional landscaping, additional structures,

²¹² Ford, "Cost of Construction a Single-Family Home in 2015."

driveway improvements, and cleanup is loosely added to cost. The detached ADU total cost rose to \$62,000, and the attached ADU cost rose to \$40,000. These costs are only estimates. When planning a construction cost, it is better to be more prepared and has an excess of capital than to be short on budget.

PROCESS ANALYSIS AND EXPANSION

The ADU Decision Support System identifies a design methodology in the conceptual design of an ADU. The process entails features of site suitability, site assessment, ADU type determination, and individual design approaches to the attached modified and detached ADU prototypes. The ADU Decision Support System also creates a basic material take-off used for design assessment. The end of the individual design processes leaves the homeowners with a conceptual plan and section of their ADU design. This conceptual plan is sufficient for an architect or licensed professional to take into a schematic level of design towards the completion of the project.

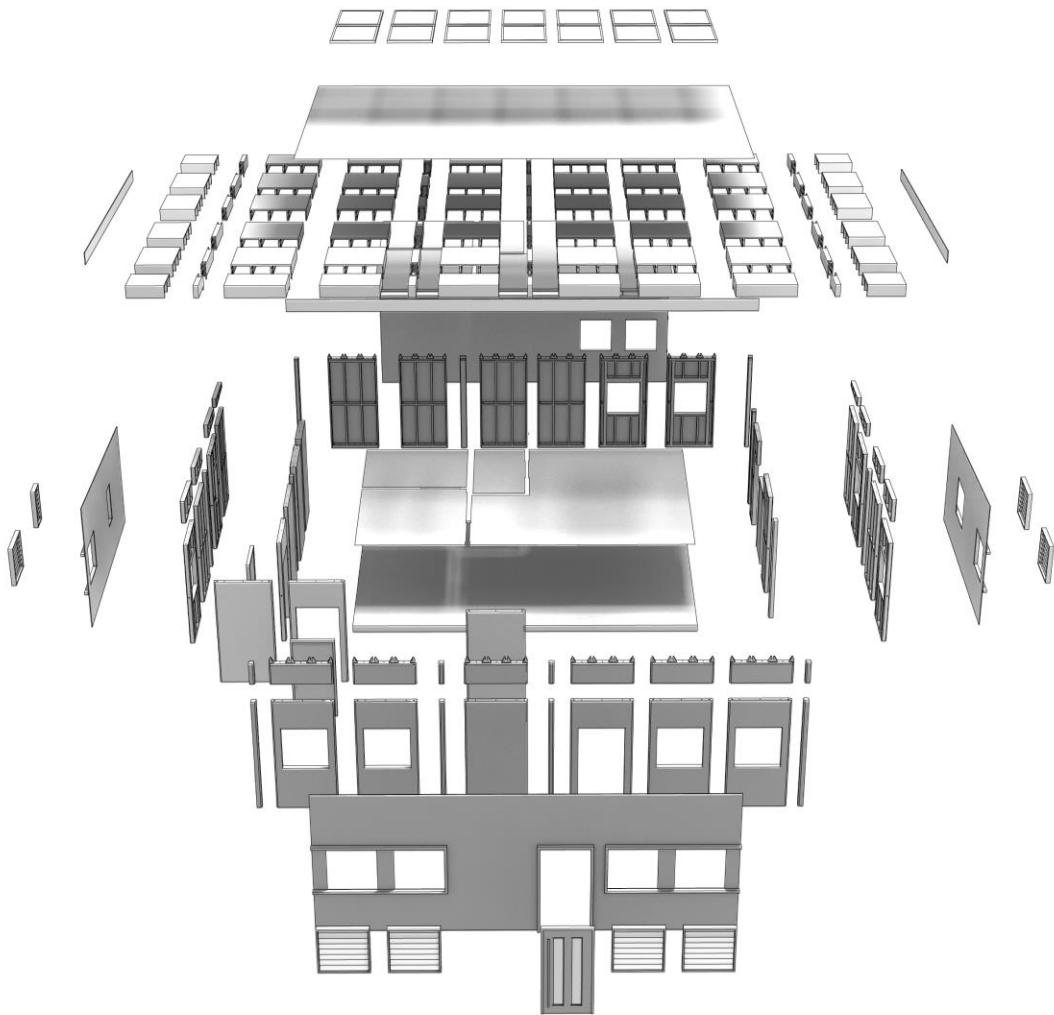

Figure 11.3 - Final detached future example design in relation exploded construction



Figure 11.4 - Final detached example design

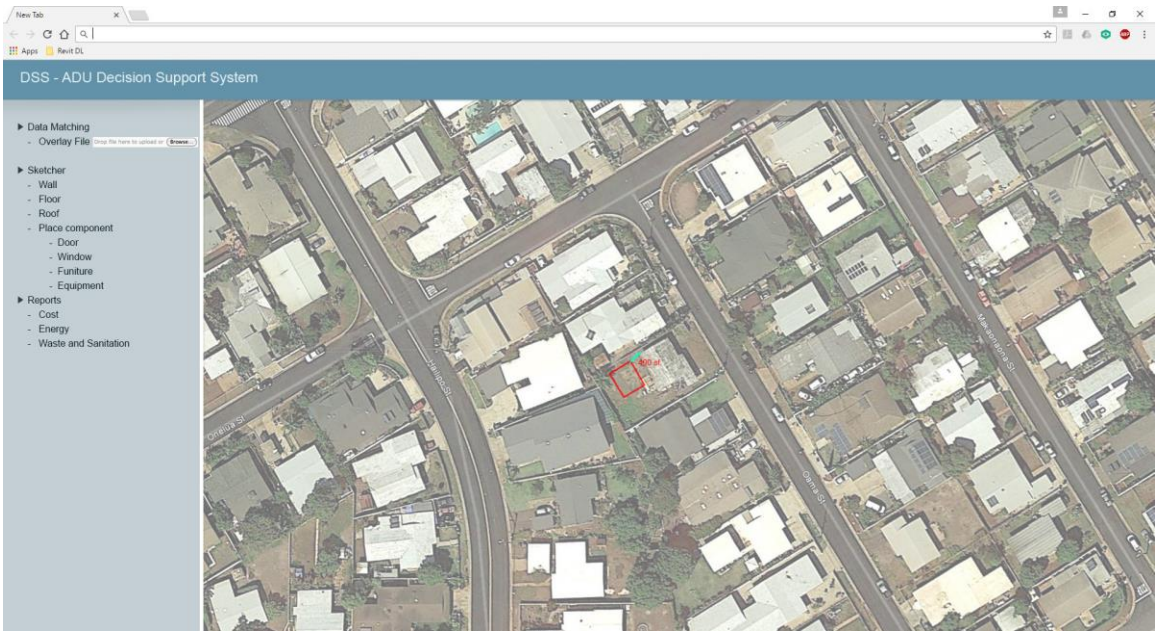

Figure 11.5 - Figure illustrating a web interface for the expansion of the Decision Support System

In the future, the ADU Decision Support System has the potential to adapt the methodology to an online user interface. The system would expedite the process of revealing the design desires of the homeowner with the engagement and consultation of an individual design professional. The interactive and informative web interface would allow the homeowners to generate their design online at no cost and would be highly

beneficial to the development of low-cost ADUs. The web interface can utilize the workflow developed in this research to walk a user through the design process. The last component of the expansion would be the interconnecting of the homeowner to the design professional who would use the conceptual design to provide a finalized ADU package ready for permitting.

CONCLUSION

In conclusion, after the passing of the Ordinance 15-41, Hawaii's homeowners remain uninformed in the means to develop an ADU. The homeowners are ill-equipped to design and develop an ADU. This research develops an ADU Decision Support System which identifies a step-by-step procedure to generate a conceptual design for an ADU in a normative fashion. Furthermore, the support system provides the homeowner with a means to assess and modify their design before engaging a design professional. As a proactive measure, the support system provides future considerations regarding wastewater, transportation, energy, and construction. Lastly, the support system has the potential for expansion to a web interface connecting willing and able ADU developers to eager design professionals. By informing and empowering the homeowner, this research can address statewide affordable housing issues and assist the homeowner to navigate the ADU development process successfully.

BIBLIOGRAPHY

- "A Giant 3d Printer Builds 10 Houses in One Day."
http://www.huffingtonpost.com/2014/09/08/3d-printed-houses_n_5773408.html.
- "Accessory Dwelling Units (Adu) Recommended Public Facilities Pre-Check Form." edited by Department of Planning and Permitting, 2016.
- Agriculture, United States Department of. "Area of Interest Map."
<https://websoilsurvey.sc.egov.usda.gov/App/WebSoilSurvey.aspx>.
- "All About Septic Systems." FamilyEducation.com.
- Allen, Edward, and Joseph Iano. "The Architect's Studio Companion." Wiley, 2011.
- Bade, Gavin. "Getting to 100% Renewables: How Hawaii Plans to Get Fossil Fuels Off the Grid." (2016). <http://www.utilitydive.com/news/getting-to-100-renewables-how-hawaii-plans-to-get-fossil-fuels-off-the-gr/416176/>.
- "Bcgb4010a Apply Structural Principles to Residential Low-Rise Constructions."
https://www.dlswb.rmit.edu.au/toolbox/buildright/content/bcgb4010a/comp_index.htm.
- Beal, Sheila. "Hawaii Fact 6 of 50: Hawaii Has 5 Counties."
<http://www.govisithawaii.com/2009/07/08/hawaii-fact-6-of-50-hawaii-has-5-counties/>.
- Calisti, Lee. "7 Questions before Taking on a Project." In *Think | Architect*, 2015.
- "Case Studies of Individual and Clustered (Decentralized) Wastewater Management Programs." edited by United States Environmental Protection Agency: Office of Wastewater Management, 2012.
- Cassiday, Rick. "Honolulu Rental Market Affordable Rental Housing Study Update, 2014." 2014.
- "Cesspools in Hawaii." State of Hawaii, Department of Health,
<http://health.hawaii.gov/wastewater/cesspools/>.
- Chapple, Karen. "Studying the Benefits of Accessory Dwelling Units." (2011).
<https://frameworks.ced.berkeley.edu/2011/accessory-dwelling-units/>.
- Ching, Francis D. K. *Architecture, Form, Space & Order*. 2nd ed. ed. New York ; London: Van Nostrand Reinhold, 1996.
- Cohen, Daniel, Matthew Sargeant, and Ken Somers. "3d Printing Takes Shape." (2014).
<http://www.mckinsey.com/quarterly/about-the-quarterly>.
- Companies, HNTB. "Benefits of Transit Oriented Development." 2016.
- "Consider Waiving Adu Fees to Boost Affordable Housing." *Staradvertiser*, 2016.
- Construction, Action. "Types of Accessory Dwelling Units."
<http://www.actonconstruction.com/types-of-adus>.
- Council, International Code. *International Building Code*. 2006.
- Council, International Code. "Accessible and Usable Buildings and Facilities." 2010.
- . "International Mechanical Code." 2006.
- . *International Residential Code*. 2006.
- Cruz, Catherine. "Sewer Hookups Slow Accessory Dwelling Unit Approvals." (2017).
<http://www.kitv.com/story/34680754/sewer-hookups-slow-accessory-dwelling-unit-approvals>.
- Cruz, City of Santa. "Accessory Dwelling Unit Manual." 2003.
- . "Accessory Dwelling Unit Program."
<http://www.cityofsantacruz.com/departments/planning-and-community-development/programs/accessory-dwelling-unit-development-program>.

- Cullen, Gordon. *The Concise Townscape*. 1961.
- DBEDT. "Measuring Housing Demand in Hawaii, 2015-2025." Department of Business Economic Development and Tourism, 2015.
- . "Urban and Rural Areas in the State of Hawaii, by County:2010." Research and Economic Analysis Division, 2013.
- Derrick, John. "Hawaii Weather and Climate Conditions." http://www.hawaii-guide.com/content/posts/hawaii_weather_and_climate_patterns.
- Dinell, Tom. "Affordable Housing the 'Ohana Way." 2014.
- Division, State of Hawaii Wage Standards. "Minimum Wage and Overtime." <http://labor.hawaii.gov/wsd/minimum-wage/>.
- "Do You Need a Building Permit?". edited by Department of Planning and Permitting, 2011.
- Ford, Carmel. "Cost of Construction a Single-Family Home in 2015." 2015.
- Fund, Clean Water Action and Clean Water. "Why Decentralize Wastewater Treatment?".
- "General Statistics." Insurance Institute for Highway Safety Highway Loss Data Institute, <http://www.iihs.org/iihs/topics/t/general-statistics/fatalityfacts/state-by-state-overview>.
- Hawaii, State of. "Chapter 12 Facility Access." Department of Health Disability and Communication Access Board.
- . "State and County Building Code Status." <http://pwd.hawaii.gov/state-county-codes-status/>.
- Heumann, Gerard. "Well-Informed Clients Come before Fine Architecture." (2014). <http://www.jpost.com/Opinion/Well-informed-clients-come-before-fine-architecture-384273>.
- Hill, John. "Feds Extend Deadline for Honolulu Rail Recovery Plan." (2016). <http://www.civilbeat.org/2016/12/feds-extend-deadline-for-honolulu-rail-recovery-plan/>.
- HNN. "Hawaii Has Highest Average List Price for Homes, but Bargains to Be Found in Some Places." <http://www.hawaiinewsnow.com/story/30495509/state-tops-list-for-average-housing-list-price-but-bargains-to-be-found-in-some-communities>.
- . "Many Oahu Homeowners Will Not Be Able to Build Adus." <http://www.hawaiinewsnow.com/story/30083330/many-homeowners-will-not-be-able-to-build-adus>.
- Hofschneider, Anita. "How Crappy Sewers Make It Hard to Build Housing in Honolulu." (2015). <http://www.civilbeat.org/2015/11/how-crappy-sewers-make-it-hard-to-build-housing-in-honolulu/>.
- Hollier, Dennis. "Broken: Stuck in Permit Purgatory." (2015). <http://www.hawaiibusiness.com/broken-stuck-in-permit-purgatory/>.
- Home, Ohana Kit ADU &. "Introducing Ohana Kit by Hawaii Adu." <http://www.hawaiiadu.com/>.
- Home, Ohana Kit ADU &. "Introducing Ohana Kit by Hawaii Adu." <http://www.hawaiiadu.com/>.
- Honolulu, City and County of. "Advanced Map." <http://gis.hicentral.com/PubWebsite/>.
- . "Bicycle Program." City and Council of Honolulu, <https://www.honolulu.gov/bicycle>.
- . "Chapter 21: Land Use Ordinance." In *Revised Ordinances of Honolulu*.
- . "Checklist for Residential Building Permit Application." edited by Department of Planning and Permitting, 2008.
- . "Housing Oahu: Affordable Housing Strategy." 2015.
- . "Ohana Zoning." CCH GIS Data Dictionary.

- . "Property Search." Department of Permitting and Planning, <http://dppweb.honolulu.gov/DPPWeb/Default.aspx?PossePresentation=PropertySearch>.
- "How Much Does It Cost to Hire and Architect?". <http://www.homeadvisor.com/cost/architects-and-engineers/hire-an-architect/>.
- Initiative, Hawaii Clean Energy. "Transforming Power in Paradise : The Hawaii Clean Energy Initiative ", 2017.
- "Inrix 2015 Traffic Scorecard Sets Benchmark for U.S. Cities as Federal Government Accelerates Smart City Spending." INRIX, <http://inrix.com/press-releases/scorecard-us/>.
- Insitute, Buckminster Fuller. "Dymaxion Bathroom." <https://www.bfi.org/about-fuller/big-ideas/dymaxion-world/dymaxion-bathroom>.
- Institute, International Living Future. "Living Building Basics." <https://living-future.org/lbc/basics/>.
- Kieran, Stephen, and James Timberlake. *Refabricating Architecture : How Manufacturing Methodologies Are Poised to Transform Building Construction*. New York, N.Y. ; London: McGraw-Hill, 2004.
- Lamb, Robert, and Michael Morrissey. "How Bridges Work." HowStuffWorks.com.
- Lau, Questor. "Accessory Dwelling Unit (Adu) Status Update." Scribd, 2016.
- . "Black Boxes and Gray Spaces: How Illegal Accessory Dwelling Find Regulatory Loopholes." University of Hawaii, 2014.
- Lawson, Mark, Raymond Ogden, and Chris I. Goodier. *Design in Modular Construction*. London: Taylor & Francis, 2014.
- Lind, Ian. "Despite Bill 20, Accessory Units Still Barred in Many Oahu Communities." In *iLind*, 2015.
- Ltd., Architects Hawaii. "Ahl's 1% Program Accessory Dwelling Unit (Adu) Project." 2015.
- Ltd., Micro Compact Home. "Micro Compact Home." <http://www.microcompacthome.com/>.
- "Luo Amendment 2015 - a Council Initiated Proposal Related to Adus." 2015.
- Martin, Elliot, and Susan Shaheen. "The Impact of Carsharing and Household Vehicle Ownership." 2011.
- "Maximizing Space with Adus." Graham Builders, <http://hawaii renovation.staradvertiser.com/2016/02/remodel/maximizing-space-adus/>.
- McCormick, Timothy. "Shear Walls." 2009.
- McKuen, Pamela. "Transit-Oriented Housing in Chicago Is Back on Track." (2016). Published electronically 9/21/16. <http://www.chicagotribune.com/classified/realestate/ct-transit-oriented-developments-re-0925-20160922-story.html>.
- Nasser, Haya El. "More Multigenerational Families in Immigrant Areas." (2012). Published electronically October 25, 2012. <http://www.usatoday.com/story/news/nation/2012/10/25/census-multigenerational-households/1653159/>.
- Padode, Pratap. "Why Cycling Should Be Mandatory in Smart Cities." <http://india.smartcitiescouncil.com/article/why-cycling-should-be-mandatory-smart-cities>.
- Pierce, Jacob. "Unit Shifter." <http://goodtimes.sc/santa-cruz-news/unit-shifter/>.
- Prothero, Randy. "Far Too Many Homes on Oahu Are Missing Building Permits." <http://hawaii randy.net/post/3813663/get-a-contractor-and-get-the-permits--->.
- "Quickfacts, Honolulu County, Hawaii." U.S. Census Bureau, 2015.
- Reid, Carlton. "How the Bicycle Beats Evolution and Why Steve Jobs Was So Taken with This Fact." (2015). <http://www.bikeboom.info/efficiency/>.

City Council, City and County of Honolulu, Hawaii. *Relating to Accessory Dwelling Units*. 20.

County of Kauai. *Relating to Additional Dwelling Unit on Other Than Residentially Zoned Lots*. Bill 2545.

City Council, City and County of Honolulu, Hawaii. *Relating to Incentives for Accessory Dwelling Units Production*. 27.

City Council, City and County of Honolulu, Hawaii. *Relating to Transit Oriented Development*. 10.

RSMeans. "Historical Cost Indexes." 2016.

"RSMeans Square Foot Costs." Kingston, MA, 2010.

Scott, Roy. "Arup Develops 3d Printing Technique for Structural Steel."
<http://www.archdaily.com/514003/arup-develops-3d-printing-technique-for-structural-steel>.

Services, Department of Environmental. "Wastewater 101." 2010.

Shimogawa, Duane. "Contractors Deal with Hawaii's Rising Construction Costs: Slideshow." (2016). <http://www.bizjournals.com/pacific/blog/2016/01/contractors-deal-with-hawaiis-rising-construction.html>.

———. "Governor Signs Bill Setting Hawaii's Renewable Energy Goal at 100%." (2015). <http://www.bizjournals.com/pacific/news/2015/06/08/governor-signs-bill-setting-hawaiis-renewable.html>.

Smith, Ryan E. *Prefab Architecture : A Guide for Architects and Construction Professionals*. Hoboken, N.J.: Wiley, 2010.

"Star Apartments." <http://www.mmaltzan.com/projects/star-apartments/>.

"State Bans New Cesspools, Offers Tax Credit to Upgrade to Sewer or Septic System." (2016). <http://khon2.com/2016/03/12/state-bans-new-cesspools-offers-tax-credit-to-upgrade-to-sewer-or-septic-system/>.

Survey, United States Geological. "Earth Explorer." <https://earthexplorer.usgs.gov/>.

"The Criteria for the Copenhagenize Index." Copenhagenize Index.

U.S. Census Bureau, 2015 American Community Survey 1-Year Estimates. "Housing Units." 2015.

———. "Income in the Past 12 Months (in 2015 Inflation-Adjusted Dollars)." 2015.

———. "Total Population." 2015.

"Wastewater Systems." edited by Department of Health, 2016.

Watanabe, June. "Building Permit Fees Grow If Work Is Already Complete." (2015). <http://www.pressreader.com/usa/honolulu-star-advertiser/20150520/281883001926578>.

Waterman, Pamela. "3d Printing with Composite Materials." 2016.

"What Is a Makerspace." <https://www.makerspaces.com/what-is-a-makerspace/>.

"What You Need to Know About Homeowners Associations in Hawaii." (2012). <http://www.hawaiilife.com/articles/2012/03/homeowners-associations/>.

"Who We Are." Clean Water Action, <http://www.cleanwateraction.org/about/who-we-are>.

Williams, Adam. "Berkeley Researchers Pioneer New Powder-Based Concrete 3d Printing Technique." 2015.

Wilson, Scott. "How to Save Money and Salvage the Rail." (2017). <http://www.civilbeat.org/2017/03/how-to-save-money-and-salvage-the-rail/>.

Yuen, Tina. "There Is More to Hawaii's Sewer Problem Than Just the Pipes." (2016).

Zientara, Ben. "How Much Electricity Does a Solar Panel Produce."
<https://solarpowerrocks.com/solar-basics/how-much-electricity-does-a-solar-panel-produce/>.

