

FATE AND CHARACTERISTICS OF DISSOLVED ORGANIC NITROGEN
THROUGH WASTEWATER TREATMENT SYSTEMS

A Dissertation
Submitted to the Graduate Faculty
of the
North Dakota State University
of Agriculture and Applied Science

By

Halis Simsek

In Partial Fulfillment
for the Degree of
DOCTOR OF PHILOSOPHY

Major Department:
Civil Engineering

August 2012

Fargo, North Dakota

North Dakota State University
Graduate School

Title

Fate and Characteristics of Dissolved Organic Nitrogen
through Wastewater Treatment Systems

By

Halis Simsek

The Supervisory Committee certifies that this *disquisition* complies with North Dakota State University's regulations and meets the accepted standards for the degree of

DOCTOR OF PHILOSOPHY

SUPERVISORY COMMITTEE:

Dr. Eakalak Khan
Chair

Dr. G. Padmanabhan

Dr. Achintya Bezbaruah

Dr. Saeed Salem

Approved by Department Chair:

October 1, 2012
Date

Dr. Eakalak Khan
Signature

ABSTRACT

Dissolved organic nitrogen (DON) represents a significant portion (25-80%) of total dissolved nitrogen in the final effluent of wastewater treatment plants (WWTPs). DON in treated wastewater, once degraded, causes oxygen depletion and/or eutrophication in receiving waters and should be reduced prior to discharge. Biodegradability, bioavailability, and photodegradability are important characteristics of wastewater derived DON and are subjects of research in this dissertation.

Four research tasks were performed. In the first task, laboratory-scale chemostat experiments were conducted to examine whether solids retention time (SRT) could be used to control DON and biodegradable DON (BDON) in treated wastewater. Nine different SRTs from 0.3 to 13 were studied. There was no correlation between effluent DON and SRTs. However, BDONs at SRTs of 0.3 to 4 days were comparable and had a decreasing trend with SRTs after that. These results indicate the benefit of high SRTs in term of producing effluent with less BDON.

The second task was a comprehensive year-round data collection to study the fate of DON and BDON through the treatment train of a trickling filter (TF) WWTP. The plant removed substantial amounts of DON (62%) and BDON (76%) mainly through the biological process. However, the discharged concentrations in the effluent were still high enough to be critical for a stringent total nitrogen discharge limit (below 5 mg-N/L).

Evolution of bioavailable DON (ABDON) along the treatment trains of activated sludge (AS) and TF WWTPs and relationship between ABDON and BDON were examined in the third task. ABDON exerted from a combination of bacteria and algae inocula was higher than algae inoculated ABDON and bacteria inoculated BDON

suggesting the use of algae as a treatment organism along with bacteria to minimize effluent DON. The TF and AS WWTPs removed 88% and 64% of ABDON, respectively.

In the last task, photodegradable DON (PDON) in primary wastewater and final effluent from TF and AS WWTPs was studied. PDON and BDON fractions of DON data in the final effluent of TF and AS WWTP samples elucidate that photodegradation is as critically important as biodegradation when mineralization of effluent DON is a concern in receiving waters.

ACKNOWLEDGMENTS

First and foremost, I would like to thank my advisor, Dr. Eakalak Khan, for the valuable guidance and advice and giving me the opportunity to work in his research laboratory. He has been very helpful to me and I have learned a great deal under his direction. He has opened up an area of research that it is very sophisticated and taught me high-level and advanced technical skills. I greatly appreciate all the support he has given me through the years. I would like to thank my committee members, Dr. Achintya N. Bezbaruah, Dr. G. Padmanabhan and Dr. Saeed Salem for their help and guidance throughout my study.

Funding for this research was provided by the District of Columbia Water and Sewer Authority (DC WASA), Washington, DC, USA, and North Dakota Water Resource Research Institute, North Dakota State University, ND, USA. I would like to thank both institutions for the support. I would like to thank Mark Blonigen, the City of Fargo (ND, USA) Wastewater Treatment Plant (WWTP) and Andrew Bradshaw, Darsey Thoen, Maria Amundson, and Kyle Juntilla, the City of Moorhead (MN, USA) WWTP for their guidance and friendly help with wastewater sample collection. Without their help, my research could not be accomplished.

I would like to thank Douglas Doehlert, USDA-ARS Wheat Quality Laboratory for providing a Varian Cary 50 UV-V spectrophotometer for the analyses of nitrate and total nitrogen. Many thanks to my colleagues, Sita Krajangpan, Anusha Balangoda, Veselina Valkov, Rabiya Shabnam, Dhritikshama Roy, Chaiwat Rongsayamanont, Thunyalux Ratpukdi, Pumis Thuptimding, Tanush Wadhawan, Murthy Kasi, Seydou

Cisse, Harjyoti Kalita, and Talal Almeelbi, in the Environmental Engineering Laboratory for their help, friendship, and encouragements. Their supports meant a lot to me.

Most importantly, I would like to thank my parents and family for all the emotional support that they have given to me during my entire doctoral study at NDSU. I want to express gratitude to my lovely daughters, Miray, Ilkay and Melis Simsek; they managed to put a smile on my face each and every day. Last but certainly not least, I want to thank my wife Senay Simsek. She has supported me through everything I have been through, and I know that she is always there for me.

TABLE OF CONTENTS

ABSTRACT	iii
ACKNOWLEDGMENTS.....	v
LIST OF TABLES	xii
LIST OF FIGURES.....	xiii
LIST OF ABBREVIATIONS	xv
LIST OF APPENDIX FIGURES	xviii
CHAPTER 1. GENERAL INTRODUCTION	1
1.1. Background.....	1
1.2. Research Problem Statement	3
1.3. Objectives and Hypotheses.....	7
1.4. Dissertation Organization	8
CHAPTER 2. LITERATURE REVIEW	10
2.1. Dissolved Organic Nitrogen	10
2.1.1. Definition of DON and its measurements	10
2.1.2. Fate of DON in water environment.....	11
2.1.3. Fate of DON in wastewater treatment systems	13
2.2. Biodegradable Dissolved Organic Nitrogen	15
2.2.1. Definition of BDON and its measurement.....	15
2.2.2. Fate of BDON in water environment	18
2.2.3. Fate of BDON in wastewater treatment systems	18
2.3. Bioavailable Dissolved Organic Nitrogen	20
2.3.1. Definition of ABDON and its measurements	20

2.3.2. Fate of ABDON in water environment	22
2.3.3. Fate of ABDON in wastewater treatment systems.....	25
2.4. Photodegradable Dissolved Organic Nitrogen	25
2.4.1. Definition of PDON and its measurement	25
2.4.2. Fate of PDON in water environment.....	26
2.4.3. Fate of PDON in wastewater treatment systems	30
CHAPTER 3. IMPACT OF SOLIDS RETENTION TIME ON DISSOLVED ORGANIC NITROGEN AND ITS BIODEGRADABILITY IN TREATED WASTEWATER.....	31
3.1. Introduction.....	31
3.2. Materials and Methods.....	34
3.2.1. Sample source, preparation, and storage	34
3.2.2. Experimental setup and operation	35
3.2.3. Parameters studied and sampling program.....	35
3.2.4. DON and BDON determination procedures	36
3.2.5. Analytical methods.....	37
3.2.6. Statistical analyses.....	38
3.3. Results and Discussion	38
3.3.1. SBOD ₅ and SCOD profiles	38
3.3.2. NH ₃ -N, NO ₂ -N, NO ₃ -N, and TDN profiles.....	40
3.3.3. DON, BDON, effluent BDON/effluent DON, and effluent DON/effluent TDN profiles	42
3.4. Summary.....	45
CHAPTER 4. FATE OF DISSOLVED ORGANIC NITROGEN IN TWO STAGE TRICKLING FILTER PROCESS	47

4.1. Introduction.....	47
4.2. Material and Methods	50
4.2.1. Description of the Fargo WWTP, and sample collection and preparation.....	50
4.2.2. DON and BDON determination procedures	51
4.2.3. Modeling strategy.....	51
4.2.3.1. Model description	52
4.2.3.2. Influent fractionation	53
4.2.3.3. Model setup, calibration, and validation.....	54
4.2.3.4. Sensitivity analysis	55
4.2.4. Analytical methods.....	58
4.2.5. Statistical analysis	58
4.3. Results and Discussion	58
4.3.1. Inorganic nitrogen species and TDN.....	59
4.3.2. Dissolved organic nitrogen.....	62
4.3.3. Biodegradable dissolved organic nitrogen	64
4.3.4. BioWin modeling	65
4.3.4.1. Model calibration.....	65
4.3.4.2. Sensitivity analysis	71
4.4. Summary.....	72
CHAPTER 5. BIOAVAILABLE AND BIODEGRADABLE DISSOLVED ORGANIC NITROGEN IN ACTIVATED SLUDGE AND TRICKLING FILTER WASTEWATER TREATMENT PLANTS.....	74
5.1. Introduction.....	74

5.2. Materials and Methods.....	76
5.2.1. Sample sources and plant description	76
5.2.2. Sample collections, and sources and preparations of inocula	77
5.2.3. DON, BDON and ABDON determination procedures	79
5.2.4. Analytical methods.....	81
5.3. Results and Discussion	81
5.3.1. Fargo WWTP	81
5.3.1.1. Inorganic nitrogen species and TDN	81
5.3.1.2. Dissolved organic nitrogen	82
5.3.1.3. Biodegradable and bioavailable dissolved organic nitrogen	85
5.3.2. Moorhead WWTP	89
5.3.2.1. Inorganic nitrogen species and TDN	89
5.3.2.2. Dissolved organic nitrogen	90
5.3.2.3. Biodegradable and bioavailable dissolved organic nitrogen	92
5.4. Summary.....	94
CHAPTER 6. BIODEGRADABLE AND PHOTODEGRADABLE DISSOLVED ORGANIC NITROGEN IN WASTEWATER: ASSOCIATION CHARACTERIZATION AND QUANTIFICATION	96
6.1. Introduction.....	96
6.2. Material and Methods	98
6.2.1. Sample source and plant description	98
6.2.2. Sample preparation.....	98
6.2.3. Inocula collection and preparation	98
6.2.4. Experimental setup and operation	99

6.2.5. DON and BDON determinations	100
6.2.6. PDON and OPBDON determinations	100
6.2.7. Analytical methods.....	102
6.3. Results and Discussion	102
6.3.1. Inorganic nitrogen species and TDN.....	102
6.3.2. Dissolved organic nitrogen.....	105
6.3.3. Biodegradable dissolved organic nitrogen	107
6.3.4. Photodegradable dissolved organic nitrogen.....	108
6.3.5. Overlapping photodegradable-biodegradable dissolved organic nitrogen.....	111
6.4. Summary	114
CHAPTER 7. CONCLUSIONS AND FUTURE WORK RECOMMENDATIONS	115
7.1. Conclusions.....	115
7.2. Recommendations for Future Work	119
REFERENCES	121
APPENDIX	127

LIST OF TABLES

<u>Table</u>	<u>Page</u>
4.1. Steady state model influent data.....	56
4.2. Model input parameters used in sensitivity analysis.....	57
4.3. Calibrated kinetic, stoichiometric and operational parameters.....	67
4.4. The values for $\delta_{i,j}$ for the most sensitive parameters of the calibrated BioWin model.....	72
5.1. Overlapping DON and DON utilizable exclusively by algae and bacteria for samples from Fargo WWTP.....	87
5.2. Overlapping DON and DON utilizable exclusively by algae and bacteria for samples from Moorhead WWTP.....	94

LIST OF FIGURES

<u>Figure</u>	<u>Page</u>
2.1. Schematic diagram of the BDON procedure (Khan et al., 2009).....	17
3.1. (a) Influent and effluent SBOD ₅ and (b) Influent and effluent SCOD of chemostat reactor at different SRTs.....	39
3.2. (a) NH ₃ -N, (b) NO ₂ -N, and (c) NO ₃ -N of chemostat reactor effluent before and after BDON incubation at different SRTs.	41
3.3. TDN of chemostat reactor influent and TDN of chemostat reactor effluent before and after BDON incubation at different SRTs.....	42
3.4. (a) Effluent DON before and after incubation and effluent BDON of chemostat reactor at different SRTs, (b) Effluent BDON/effluent DON of chemostat reactor at different SRTs.....	44
3.5. Effluent DON/effluent TDN before and after incubation of chemostat reactor at different SRTs.....	45
4.1. A simplified schematic diagram of the Fargo WWTP.....	51
4.2. Conceptual nitrogen transformations in the BioWin model.....	53
4.3. The BioWin steady state model for the City of Fargo WWTP. BOD TF – BOD trickling filters; NH ₃ TF – nitrification trickling filters.	55
4.4. (a) Dissolved ammonia (b) nitrite (c) nitrate and (d) total nitrogen in the Fargo wastewater after various treatment units before and after incubation.	61
4.5. (a) DON and BDON (b) dissolved organic nitrogen as a percentage of total dissolved nitrogen (c) BDON as a percentage of DON during summer and winter months in the Fargo wastewater after various treatment units.	63
4.6. BioWin model simulated versus measured profiles of (a) BOD and COD (b) ammonia, nitrite and nitrate, TDN and (c) DON and BDON data along the treatment plant.	68
5.1. A simplified schematic diagram of the City of Moorhead WWTP.....	77
5.2. A simplified schematic diagram of the City of Fargo WWTP.....	78

5.3. Schematic diagram of the ABDON procedures (modified from Simsek et al., 2012).....	80
5.4. (a) TDN before and after incubation, (b) DON before and after incubation, (c) DON as a percentage of TDN before and after incubation for samples through the treatment train of the City of Fargo WWTP.....	83
5.5. (a) Effluent BDON and effluent ABDON, (b) Effluent BDON as a percentage of effluent DON, effluent ABDON as a percentage of effluent DON for samples through the treatment train of the City of Fargo WWTP.....	88
5.6. (a) TDN before and after incubation, (b) DON before and after incubation, (c) DON as a percentage of TDN before and after incubation for samples through the treatment train of the City of Moorhead WWTP.....	91
5.7. (a) Effluent BDON and effluent ABDON, (b) Effluent BDON as a percentage of effluent DON, effluent ABDON as a percentage of effluent DON for samples through the treatment train of the City of Moorhead WWTP.....	93
6.1. Schematic diagram of the PDON procedures.....	101
6.2. (a) Nitrite before and after UV light exposure, (b) Ammonium before and after UV light exposure, and (c) TDN before and after UV light exposure for primary treated wastewater and final effluent samples from the City of Fargo and Moorhead WWTP.....	104
6.3. (a) DON before and after UV light exposure, (b) DON as a percentage of TDN before and after UV light exposure for primary treated wastewater and final effluent samples from the City of Fargo and Moorhead WWTP.	106
6.4. (a) BDON _i and PDON after UV light exposure, (b) BDON _i as a percentage of DON _i , PDON as a percentage of DON _i for primary treated wastewater and final effluent samples from the City of Fargo and Moorhead WWTP.	108
6.5. (a) PDON for 3 or 6 days of light exposure, (b) PDONs as a percentage of DON _i for primary treated wastewater and final effluent samples from the City of Fargo and Moorhead WWTP.	110
6.6. (a) OPBDON for 6 days of light exposure for primary treated wastewater samples, (b) OPBDON for 6 days of light exposure for final effluent samples from the City of Fargo and Moorhead WWTP.	112

LIST OF ABBREVIATIONS

ABDON.....	Bioavailable dissolved organic nitrogen
ANOVA.....	Analysis of variance
AOB.....	Ammonia oxidizing bacteria
AS.....	Activated sludge
BDON.....	Biodegradable dissolved organic nitrogen
BDON _f	Final BDON (after UV light exposure)
BDON _i	Initial BDON (before UV light exposure)
BOD.....	Biochemical oxygen demand
Chl-a.....	Chlorophyll a
COD.....	Chemical oxygen demand
CON.....	Colloidal organic nitrogen
DCAA.....	Dissolved combined amino acid
DDW.....	Distilled deionized water
DFAA.....	Dissolved free amino acid
DI.....	Deionized
DIN.....	Dissolved inorganic nitrogen
DNH ₃ -N.....	Dissolved ammonia nitrogen
DNO ₂ -N.....	Dissolved nitrite nitrogen
DNO ₃ -N.....	Dissolved nitrite nitrogen
DO.....	Dissolved oxygen
DOC.....	Dissolved organic carbon
DOM.....	Dissolved organic matter

DON.....Dissolved organic nitrogen

DON_{bf}.....Final DON for seed control

DON_{bi}.....Initial DON for seed control

DON_{dark}.....DON after dark incubation

DON_f.....Final DON after BDON incubation

DON_{f(UV, 3 or 6 days)}Final DON after 3 or 6 days of UV light exposure

DON_i.....Initial DON (before incubation or UV light exposure)

DON_{UV}.....DON after UV light exposure

DPA.....Dissolved primary amine

EDTA.....Ethylenediaminetetraacetic acid

ENR.....Enhanced nutrient removal

EON.....Effluent organic nitrogen

EPA.....Environmental Protection Agency

GLM.....General Linear Models

HS.....Humic substances

MGD.....Million gallons per day

MLSS.....Mixed liquor suspended solids

N.....Nitrogen

NH₃.....Ammonia

NH₄⁺.....Ammonium

NO₂⁻.....Nitrite

NO₃⁻.....Nitrate

NOB.....Nitrite oxidizing bacteria

PDON.....Photodegradable dissolved organic nitrogen
PDON_{UV, 3 or 6 days}.....Photodegradable DON after 3 or 6 days of UV light exposure
PON.....Particulate organic nitrogen
SBOD.....Soluble biochemical oxygen demand
SCOD.....Soluble chemical oxygen demand
SRT.....Solids retention time
TDN.....Total dissolved nitrogen
TF.....Trickling filter
TKN.....Total Kjeldahl nitrogen
TN.....Total nitrogen
UV.....Ultraviolet
WWTP.....Wastewater treatment plant

LIST OF APPENDIX FIGURES

<u>Figure</u>	<u>Page</u>
A.1. (a) Dissolved ammonia, (b) Dissolved nitrite, and (c) Dissolved nitrate before and after incubation for samples from City of Fargo WWTP.....	127
A.2. (a) Dissolved ammonia, (b) Dissolved nitrite, and (c) Dissolved nitrate before and after incubation for samples from City of Moorhead WWTP.	128
A.3. Nitrate before and after UV light exposure for primary treated wastewater and final effluent samples from the City of Fargo and City of Moorhead WWTPs.....	129
A.4. Nitrite after BDON incubation for primary treated wastewater and final effluent samples from the City of Fargo and City of Moorhead WWTPs.....	129

CHAPTER 1. GENERAL INTRODUCTION

1.1. Background

Availability of excess nutrients is known to cause eutrophication in natural surface waters such as lakes, rivers, and estuaries. Excess nitrogen (N) promotes algal growth and causes oxygen depletion resulting in fish kill and in turn affecting the commercial and recreational activities of the waters. The largest amount of nitrogen entering the water body is from agricultural lands that use nitrogen fertilizers. Animal population and associated animal wastes, atmospheric deposition (from industrial facilities and vehicle exhaust), and runoff from roadways and residential areas are other nitrogen sources. Furthermore, effluents from wastewater treatment plants (WWTPs) are important nitrogen sources in receiving natural waters. Due to the recent advances in treatment processes, WWTPs equipped with nitrification and denitrification processes (biological nitrogen removal) are achieving more than 95% removal of dissolved inorganic nitrogen (DIN). Most of the WWTPs equipped with these advanced processes are achieving effluent total dissolved nitrogen (TDN) of 10 mg/L or less (Urgun-Demirtras et al., 2008, Sattayatewa et al., 2009, Simsek et al., 2012). Dissolved organic nitrogen (DON) usually represents a significant portion of nitrogen (it can be as high as 80% of TDN) in the final effluent of these WWTPs.

Knowledge on biodegradability, bioavailability, and photodegradability of wastewater DON is crucial for a better understanding of the fate of DON through the treatment trains of WWTPs or in the receiving waters. The biodegradability of effluent DON is an important issue because biodegradable DON (BDON) could support bacterial and/or algal growth and/or consume dissolved oxygen (DO) in receiving waters. BDON is

the portion of DON that can be mineralized by an acclimated mixed bacterial culture (Khan et al., 2009). Murthy et al. (2006) conducted an experiment using filtered denitrified secondary effluent samples from four different treatment plants. They observed effluent BDON in two out of four plants. They found 25% and 33% of DON was BDON for these two plants based on 20 days of incubation. They concluded that the BDON method that they used needs to be improved including alternative inoculum, filter type, and incubation period. Their goal was to collect BDON data from the WWTP, rather than to develop a new BDON method. Sattayatewa et al. (2009) found that 41-43 % of DON is BDON in effluent samples from a full-scale 4-stage Bardenpho process.

Because of its complex structure, DON is not readily available to some species in aquatic ecosystems. DON degradation converts high molecular weight compounds to low molecular weight compounds, and finally this degradation make DON bioavailable to some species including algae, bacteria, micrograzers, bacterioplankton, cyanobacterium, and phytoplankton (Pehlivanoglu and Sedlak, 2004; Sattayatewa et al., 2009; Bronk et al., 2010; Filippino et al., 2011; Loh et al., 2011). Degraded low molecular compounds could be ammonium, amino acids, humic substances (HS), and urea and these substances could be bioavailable to the species mentioned above (Bushaw-Newton and Moran, 1999; Wiegner et al., 2006; Bronk et al., 2010). Bioavailable DON (ABDON) is crucial in receiving water bodies since it causes excessive growth of unwanted species and ultimately reduces the quality of surface waters.

Algae in the receiving water utilize ABDON for their growth; however, wastewater derived effluent DON is not readily bioavailable to algae in the absence of bacteria; about half of the DON is bioavailable to algae in the presence of bacteria during a 14-day of

incubation period (Pehlivanoglu and Sedlak, 2004). The residence time of DON in the receiving waters is critical since DON is not readily bioavailable. Even though certain phytoplankton has the ability to use DON directly, most of the algae use available inorganic nitrogen in the system. DON has to be metabolized by bacteria to make it bioavailable to algae. ABDON consists of mostly compounds with a molecular weight of < 1,000, which make up of about 30% of DON (Pehlivanoglu and Sedlak, 2004).

In addition to some type of bacteria, sun light or artificial light decompose the degradable part of DON to less complex substances; however some part of DON may not be completely degradable (refractory). DON degradable by light energy is named as photodegradable DON (PDON). Light exposure breaks down the degradable part of DON to less complex substances and finally makes DON bioavailable to aquatic species. A relationship between BDON and PDON is not known well.

Photochemical release of bioavailable nitrogen from aquatic dissolved organic matter (DOM) in marine and freshwater ecosystems was studied by Bushaw et al. (1996). They investigated whether sunlight (and/or artificial light that is adjusted to match with sunlight beams) exposure causes DOM to release nitrogen-rich compounds and enhances the breakdown of humic substances to lower molecular weight compounds. Results showed that after sunlight exposure on DOM, release of ammonium was observed. Sunlight exposure time affected the efficiency of photodegradation of DON and photoproduction of ammonium was about 16% of DON in a longer exposure time (72 h).

1.2. Research Problem Statement

Recent studies indicate that a major portion of treated effluent TDN is generally in an organic form as DON. DON value ranges from 25% to 80% of the effluent TDN. DON

concentration in the secondary treated effluent typically ranges from 1 to 5 mg N/L (Pehlivanoglu-Mantas and Sedlak, 2006; Urgun-Demirtras et al., 2008; Sattayatewa et al., 2009; Simsek et al., 2012). Since high DIN removal has been achieved by WWTPs using the best available technologies, the future target for the treatment plants will be the removal of DON to reduce effluent TDN concentration. Lately, the fate of DON and BDON has gained attention because of more stringent regulations on total nitrogen (TN) concentration in treated wastewater effluent. Some part of DON cannot be removed (refractory) using current wastewater treatment technologies and is discharged to receiving waters. Once entering the receiving waters, biodegradation of DON (to ammonia and eventually nitrate) could start if optimum conditions such as DON residence time, type and amount of bacterial community, DO level, and temperature are met. The produced ammonia and nitrate are used by algae and other phytoplankton and consequently excessive growth of algae and phytoplankton cause eutrophication in receiving waters.

There have been studies on the fate and characteristics of wastewater derived DON (Parkin and McCarty, 1981a, 1981b; O'Shaughnessy et al., 2006; Murthy et al., 2006; Pehlivanoglu-Mantas and Sedlak, 2006; Sattayatewa et al., 2009) and BDON (Murthy et al., 2006; Sattayatewa et al., 2009). However, there has been no established procedure available until 2009 to measure BDON in wastewater. Murthy et al. (2006) used a BDON test that was modified from the traditional biochemical oxygen demand (BOD) test with a 20-day incubation period; however, they concluded that the BDON method they used needs to be improved by using alternate bacterial inoculum and a longer incubation period. Later on, a BDON determination procedure was developed by Khan et al. (2009) by using diluted mixed liquor suspended solids (MLSS) as a seed with 20 days of incubation.

Producing BDON data by employing the procedure developed by Khan et al. (2009) could provide engineers and scientists a better understanding of the fate and characteristics of DON and BDON in receiving waters and treatment plants. This understanding will help to protect receiving waters since BDON removal reduces TDN concentration in the treatment plant effluent.

Some studies have been conducted to understand the fate and behavior of treated effluent BDON (Murthy et al., 2006; Sattayatewa et al., 2009); however, none of the studies used a laboratory scale chemostat reactor simulation. Conducting chemostat experiments and monitoring important wastewater treatment plant parameters such as solids retention time (SRT) and BOD along with DON and BDON would be a good approach to understand the fate and characteristics of DON and BDON. Chemostat operation and setup are simple, less laborious, and inexpensive.

BDON removal has been investigated for some of the WWTP processes, such as 4-stage Bardenpho process (Sattayatewa et al., 2009), two-stage nitrification and denitrification process and step-feed biological nutrient removal process (Khan et al., 2009). However, there has been no BDON study conducted for trickling filter WWTPs. Because of increasing stringent TDN discharge regulations, two-stage trickling filter WWTPs might be forced to reduce effluent TDN concentration. Collecting data on the fate of DON and BDON through the trickling filter treatment trains could help in understanding how to reduce effluent TDN concentration. Seasonal effects on DON and BDON through a WWTP particularly for a trickling process in a region with severe winter where the difference in temperature between winter and summer is dramatic has not been examined. Seasonal differences in DON and BDON and their removal by various treatment units of a

WWTP could be valuable information for regulatory agencies and WWTPs when a new nitrogen limit in the effluent is considered in the future.

ABDON indicates the potential effect of effluent DON on the quality of receiving waters, because ABDON could support the growth of algae and cause oxygen depletion in the aquatic system. Although many studies exist on the ABDON from natural and anthropogenic sources (Bushaw et al., 1996; Bronk et al., 2006; Filippino et al., 2011) limited studies are available on the ABDON from WWTPs (Pehlivanoglu and Sedlak 2004, 2006; Urgun-Demirtas et al., 2008; Sattayatewa et al., 2009). The Printz Algal Assay Bottle Test, a U.S. Environmental Protection Agency (EPA) method was adapted by Urgun-Demirtas et al. (2008) to determine ABDON by using a commercially available algae inoculum. They were successful in determining ABDON exertion in low TDN effluent samples and concluded that ABDON was bioavailable to algae in the presence of bacteria. However, they suggested that their method needs to be applied to different treatment effluents since the nature and characteristics of DON could be different. Earlier studies on ABDON did not focus on its fate through various stages of WWTPs. There has been no comprehensive data collection available on the fate of ABDON along wastewater treatment trains.

Light exposure breaks down DON to lower molecular weight labile substances, and ultimately makes DON biologically available to algae, bacteria, and phytoplankton in the aquatic ecosystem (Moran and Zepp, 1997; Bushaw-Newton and Moran, 1999; Koopmans and Bronk, 2002; Vähätalo and Zepp, 2005; Bronk et al., 2010). Effect of light exposure on DON in wastewater is important to understand the fate of DON through treatment plants and in receiving waters. There has been no study that investigates thoroughly

whether photodegradable portion of DON is made up of BDON and/or non-BDON (NBDON). There could be overlapping between PDON and BDON. This overlapping portion of DON is more problematic in water environment because it has more chances to be broken down to labile components by either photodegradation or biodegradation or both. Quantifying overlapping DON and understanding what WWTPs do to it are the first step towards that. Only one study has been conducted by Bronk et al. (2010) to investigate photochemical release and subsequent PDON production of effluent organic nitrogen from two enhanced nutrient removal (ENR) WWTPs. In that study, only the final effluent samples were experimented to determine photolabile compounds released from DON by light exposure and the study did not determine if any portion of PDON was also biodegradable or not.

1.3. Objectives and Hypotheses

The objectives and corresponding hypotheses of this research are:

1. To investigate the effect of SRT on DON and BDON in treated wastewaters.

Hypothesis: DON and BDON concentrations in treated effluent decrease with the increase of SRT.

2. To investigate the fate of DON and BDON in a two-stage trickling filter wastewater treatment train by a year-round data collection.

Hypothesis: DON and BDON concentrations decrease through a two-stage trickling filter WWTP train from influent to effluent.

3. To examine the evolutions of BDON and ABDON through the treatment train of a two-stage trickling filter WWTP and an activated sludge WWTP.

Hypothesis: BDON and ABDON concentrations decrease from influent to effluent in a two-stage trickling filter and in an activated sludge treatment train.

4. To examine the relationship between PDON and BDON in primary treated wastewater and final effluent from two-stage trickling filter and activated sludge WWTPs.

Hypothesis: BDON is associated with PDON as well as non-PDON (NPDON) for both types of samples from two-stage trickling filter and activated sludge WWTPs.

1.4. Dissertation Organization

This dissertation is divided into 7 chapters. Chapter 1 contains introduction, research justification, objectives and related hypotheses, and this section. Chapter 2 presents a critical literature review of the published papers on DON, BDON, ABDON, and PDON, and their fates and behaviors in water environments and in WWTPs. Chapter 3 describes work on chemostat experiments and is based on a manuscript entitled “Effects of Solids Retention Time in Chemostat on Dissolved Organic Nitrogen and its Biodegradability in Treated Wastewater.” This manuscript will be submitted for journal publication. Chapter 4 is based on a manuscript entitled “Fate of Dissolved Organic Nitrogen in Two Stage Trickling Filter Process.” This manuscript has been published in *Water Research* (Simsek et al., 2012). Chapters 5 and 6 describe the work entitled “Fate of Bioavailable and Biodegradable Dissolved Organic Nitrogen in Two-Stage Trickling Filter and Activated Sludge Wastewater Treatment Plants” and “Biodegradable and Photodegradable Dissolved Organic Nitrogen in wastewater: Association Characterization and Quantification”, respectively. The materials in Chapters 5 and 6 have been submitted

for journal publication. Chapter 7 presents conclusions and recommendations for future work.

CHAPTER 2. LITERATURE REVIEW

2.1. Dissolved Organic Nitrogen

2.1.1. Definition of DON and its measurements

DON is a primary nutrient and plays an important role in nitrogen cycling in surface waters including lakes, rivers, and estuaries. The chemical composition of wastewater effluent DON is complicated because of its multiple forms of organic nitrogen in both bioavailable and refractory forms. The identifiable effluent DON usually accounts for less than 10% of DON and major portion of DON most probably consists of polymerized biological compounds (Pehlivanoglu-Mantas and Sedlak, 2006). Hence, the fate and behavior of DON is not well defined in the natural ecosystems. DON is biochemically transformable through ammonification, nitrification, and denitrification by bacteria first to ammonia N ($\text{NH}_3\text{-N}$) and nitrate N ($\text{NO}_3\text{-N}$), and then back to atmospheric N. Effluent DON may consist of urea, amino acids, amino sugars, proteins, nucleic acids, fulvic acids, humic acids, and a variety of uncharacterized components. Urea can be readily converted to ammonium carbonate and it can be found as ammonium instead of urea in aquatic system or municipal wastewater (Pehlivanoglu-Mantas and Sedlak, 2006).

Surface waters are often enriched with DON originating from agricultural and industrial areas as well as wastewater treatment facilities. These excess nutrients encourage algal growth, cause oxygen depletion and affect socio-economic life. Also, DON is a nutrient that is important to primary production in marine ecosystem. Many wastewater treatment plants are forced to reduce effluent total nitrogen concentration to 3-4 mg N/L or lower to protect receiving waters. Since treatment plants are capable of removing about

95% of DIN, removal of DON has gained attention in order to meet the stringent N discharge limit.

There is no method to measure DON directly; however, it can be determined using a nitrogen mass balance equation. Dissolved inorganic nitrogen species and TDN must be determined to calculate DON concentration in a sample (Equation 2.1). Another way for determining DON is by measuring total Kjeldahl nitrogen (TKN) and dissolved ammonia nitrogen (DNH₃-N). DON is the difference between TKN and DNH₃-N (Equation 2.2).

$$\text{DON (mg N/L)} = \text{TDN} - [\text{DNH}_3\text{-N} + \text{DNO}_2\text{-N} + \text{DNO}_3\text{-N}] \quad (2.1)$$

$$\text{DON (mg N/L)} = \text{TKN} - \text{DNH}_3\text{-N} \quad (2.2)$$

where DNH₃, DNO₂, and DNO₃ are dissolved ammonia, nitrite and nitrate, respectively.

2.1.2. Fate of DON in water environment

DON is a potential nitrogen source for bacterial, algal, and phytoplankton communities in aquatic environment. Particularly, ammonium and urea, released from DON by biodegradation or photodegradation, are known to be an important low-molecular weight N source for these communities. Because of its complex structure, fate and behavior of DON in the water environment is not well understood. Biomineralization of DON is affected by external environmental conditions, such as residence time, types of microbial communities, substrate complexity, temperature, pH, and DO in the aquatic ecosystem.

Berman et al. (1999) investigated the potential release of ammonium and/or urea from DON in freshwater (lake) samples. All the samples were filtered through either a pre-rinsed 1.0 µm pore-sized Nuclepore filters or 1.2 µm pore-sized Opticap filters to remove all the phytoplankton with the exception of bacteria. Experiments were conducted in the

dark for 7 to 14 days of incubation periods. Samples were amended by various DON compounds (arginine, glucosamine, guanine, hypoxanthine, lysine, ornithine, thymine, or adenine) to concentrations of 40 μM DON in the sample. NH_4^+ and urea were monitored during the incubation period. Results showed that NH_4^+ concentration in 5 different lake samples (amended by glucosamine, guanine, hypoxanthine, lysine, or ornithine) increased while in 2 samples (augmented by thymine or adenine) it did not increase. Moreover, only hypoxanthine, guanine, or arginine samples had increases in urea concentration. It was concluded that DON, which was broken-down to NH_4^+ and urea by bacteria, could be important in supplying nitrogen nutrition to the phytoplankton community.

Another study was conducted to investigate DON in riverine DOM as a significant source of bacterial production in coastal water (Amon and Benner, 1996). It was shown that high molecular weight of DOM (> 1 kDa) is more available for bacterial utilization than the low molecular weight of DOM (< 1 kDa). The large portion of riverine DOM is a macromolecular organic compound known as humic substances (Thurman, 1985). Even though some scientists agreed that HS was a refractory compound for bacterial community (Geller, 1983, Bauer et al., 1992), other scientists proved that some bacteria can use HS as a substrate (Tranvik 1988; Moran and Hadson, 1990; Bushaw et al., 1999) and phytoplankton community increased when HS was introduced to algal culture (Graneli and Moreira, 1990).

Wastewater originated DON, discharged continuously into water environment, is also an important source of nitrogen. Nam and Amy (2008) discovered that downstream DON level was 2-2.5 times higher than upstream DON levels and they concluded that wastewater treatment effluent was the main contributor for this increase. Regulations on

wastewater effluent N limits are becoming very stringent for some receiving water bodies. This fact has forced some WWTPs to reduce effluent DON concentration prior to discharge. The Chesapeake Bay is an example for the case since it is one of the most nutrient-sensitive coastal marine ecosystems in the United States.

Exposure to sunlight has an important impact on the fate of DON in the environment. Photochemical degradation of DON in dissolved organic matter is an important step to produce nutritious component in estuaries and near shore marine waters. Photochemical degradation of DON produces low molecular weight and labile substances. Particularly, HS are readily biodegradable when exposed to sunlight in the environment (Vähätalo et al., 2005; Koopmans et al., 2002; Bronk et al., 2010).

2.1.3. Fate of DON in wastewater treatment systems

Researchers have reported that DON concentrations in treated wastewater effluent are between 0.7 and 2.1 mg N/L depending on the treatment methods (Parkin and McCarty, 1981a; Murthy et al., 2006; Urgun-Demirtas et al., 2008; Pehlivanoglu-Mantas and Sedlak, 2008; Simsek et al., 2012). DON in raw wastewater (treatment plant influent) can be separated into two portions as biodegradable and refractory DON. The biodegradable portion of DON is substantially removed in activated sludge (AS) treatment plant and AS effluent consists of mainly refractory portion of DON (Parkin and McCarty, 1981a; Murthy et al., 2006). However, it has not been reported whether the main design and operational parameter in activated sludge process (SRT) affects effluent DON and its biodegradability.

Regardless of the efficiency of WWTP and influent DON level, effluent would still contain DON because bacterial growth and decay could produce DON during the treatment

operation. The DON produced by bacteria can be either biodegradable or refractory (Parkin and McCarty, 1981a; Sattayatewa et al., 2009). Parkin et al. (1981a) reported that up to 40% of effluent DON may be produced during the biological treatment plant operation and suggested that additional physical and/or chemical treatment following biological treatment would be needed to remove DON completely from the wastewater effluent. However, complete removal of DON has not been reported.

Parkin and McCarty (1981a) showed that influent DON is highly biodegradable (> 80%). About 70% of the total influent DON is removed in suspended growth systems of WWTPs. DON removal increases when the MLSS concentration increases. Bacterial activity and food/microorganism ratio (depending on the characteristics of substrate and microorganisms) are crucial factors for DON removal. More DON is excreted during the logarithmic growth stage compared to stationary stage and DON that produced during the logarithmic stage is removed during the stationary stage (Parkin and McCarty, 1981a).

Sattayatewa et al. (2009) investigated nitrogen species (Ammonium, nitrite, nitrate, and DON) within a 4-stage Bardenpho treatment process. Results showed that nitrogen species transformed from one species to another along the units of the process. Influent ammonium concentration decreased gradually in the treatment process while nitrate concentration increased, as expected. Nitrification was not observed in the primary anoxic zone, and ammonium was completely nitrified to nitrate in the secondary aerobic zone. An increase in organic nitrogen was also observed in the primary anoxic zone. Denitrification occurred in the secondary anoxic zone and nitrate decreased to about 0.5 mg N/L. Nitrite was in very low concentrations (< 0.03 mg N/L) through the entire treatment process.

Sattayatewa et al. (2009) further reported that dilutions from return activated sludge and internal recycling affected the concentration of nitrogen species in the treatment process. DON concentration from different treatment units varied. Primary effluent had an average of 1.11 mg N/L of DON. DON released in the primary anoxic zone due to either microbial activities or heterotrophic denitrification. DON concentration changed when the influent characteristics and operational conditions were changed. DON, produced in the primary anoxic zone, did not substantially change in the next three sections, which were primary aerobic, secondary anoxic, and secondary aerobic. DON, produced in the primary anoxic zone, either was not removed in the next three zones or was simultaneously taken up and released by biological activities.

2.2. Biodegradable Dissolved Organic Nitrogen

2.2.1. Definition of BDON and its measurement

BDON is a biodegradable part of DON that can be mineralized by bacteria when the optimum conditions are attained. DON is an important N source for bacteria which biomineralize it to ammonia, a preferred N source for algae and phytoplankton. Since excessive amounts of algal growth have negative impact on aquatic ecosystems, BDON in the system needs to be minimized. There are many sources of BDON in the receiving water bodies with wastewater derived BDON as the main one. BDON removal should be performed in the treatment plant before discharging effluent to the aquatic ecosystem.

Murthy et al. (2006) used a method similar to the BOD procedure to measure BDON in denitrified secondary effluent samples from 4 different advanced treatment plants in the Chesapeake Bay (Washington D.C., USA) region. Settled domestic wastewater was used as a seed source for the BDON procedure which relied on DON

reduction during an incubation period of 20 days. Samples were collected prior to the filtration. All the samples were filtered through a 1.0 μm pore-size glass fiber filter, and DON was measured before and after the incubation. They recommended that their BDON procedure needs to be improved by applying different type and size of bacterial inoculum, using a different type of filter, and applying a longer incubation period.

Khan et al. (2009) developed a BDON procedure (Figure 2.1) by adapting traditional BOD and biodegradable dissolved organic carbon (Khan et al., 1998) procedures. Their goal was to create a method that would be suitable for routine measurement of BDON in WWTPs. They concentrated on various aspects of the procedure including type and concentration of bacterial inoculum, incubation period, and filtration requirement after the incubation process. Wastewater samples were collected from two nutrient removal WWTPs while four standard DON solutions containing urea and glutamic acid were prepared in the laboratory. The method was tested using 4 different MLSS inoculum concentrations (30, 60, 120, and 240 mg/L) and almost complete exertion was attained by 240 mg/L MLSS. Incubation period was continued to 180 days; however, significant BDON exertion was observed in the first 20 days of incubation period. After 20 days, BDON exertion was limited. They also concluded that sample filtration after incubation was not necessary.

The detail of the BDON procedure conducted by Khan et al. (2009) (Figure 2.1) is as follows. A portion of the filtered sample was used for immediate analysis of TDN and inorganic nitrogen species (ammonia, nitrite, and nitrate). DON was determined from the difference between measured TDN and measured DIN species using Equation 2.1. The value was recorded as initial DON (DON_i). The remaining filtered sample was mixed with

2 mL of acclimated inoculum in a 300 mL BOD bottle. The solution in the bottle was shaken thoroughly to aerate and placed in an incubator in the dark at 20°C for 20 days. During the incubation period, the solution in the bottle was manually shaken to aerate at least once every day to maintain aerobic conditions. A seed control (distilled deionized water (DDW), sample b) was treated the same way as the samples (DON_{bi} and DON_{bf}). After 20 days of incubation, all nitrogen species in the supernatant were measured to determine final DON (DON_f). BDON was calculated according to Equation 2.3.

$$BDON \text{ (mg N/L)} = (DON_i - DON_f) - (DON_{bi} - DON_{bf}) \quad (2.3)$$

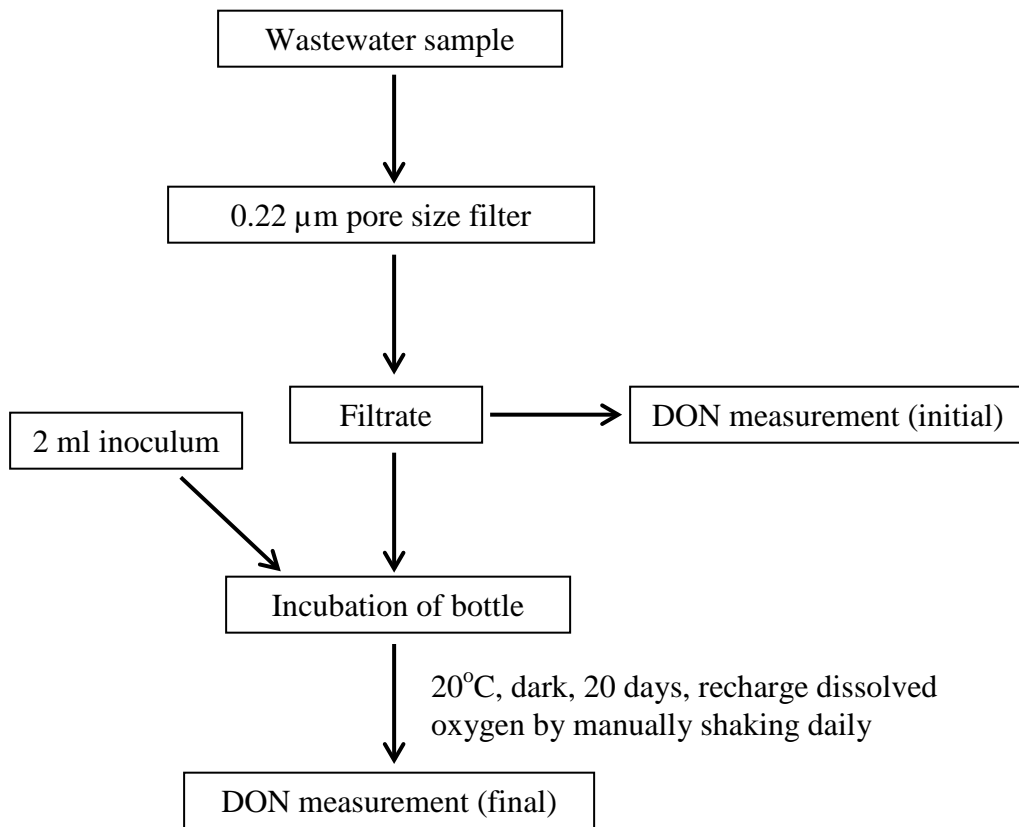

Figure 2.1. Schematic diagram of the BDON procedure (Khan et al., 2009).

2.2.2. Fate of BDON in water environment

BDON plays a crucial role in many chemical and biological processes in natural ecosystem. However, there has been no study available on the fate of BDON in water environment.

2.2.3. Fate of BDON in wastewater treatment systems

DON concentration in treated effluent from WWTPs equipped with nitrification and denitrification processes typically ranges from 1 to 5 mg N/L. Although effluent DON is recalcitrant to the treatment processes, studies showed that about 50% of the effluent DON is biodegradable by bacteria (Murthy et al., 2006; Khan et al., 2009; Sattayatewa et al., 2009).

Murthy et al. (2006) measured BDON in effluent samples from four advanced treatment plants in the Chesapeake Bay region. These plants were equipped with nutrient removal technologies. They had less TDN concentrations; however, DON percentage of TDN was very high. BDON was observed in the effluent samples from two treatment plants at 25% and 33% of DON. Even though DO decreased 4 to 6 mg/L in all the samples during the 20 days of incubation, significant DON reduction (BDON exertion) was not observed in samples from the other two treatment plants. There could be less refractory carbonaceous sources available in the system for the bacterial inoculum, or non-growth linked carbon degradation took place. In addition, the BDON method used was not tested well enough particularly on inoculum conditions and different incubation periods

Parkin et al. (1981a, 1981b) conducted a laboratory batch study on the removal of DON in an activated sludge system. They concentrated on DON production and excretion by bacteria. Concentrated bacteria cultures (MLSS) were obtained from a complete mixed

activated sludge process in Palo Alto, CA, USA. They found that effluent DON consists of refractory DON and BDON. Also, some part of effluent DON would be carried from the influent (passed through the treatment plant without any conversion) while some part of DON could be produced during the biological activity in the treatment plant. In their experiment, 80% of BDON was removed. Aeration time and MLSS concentrations affected the concentration of effluent BDON. They concluded that proper control of operational parameters of the activated sludge system can increase BDON removal.

Sattayatewa et al. (2009) determined BDON in the final effluent of the Parkway WWTP (Laurel, Maryland, US). They separated the samples in two portions; one set of samples stayed as original samples while nitrate was removed (pretreated) from the other set of the samples by ion exchange. Maximum BDON in DON was found to be 41-43% for untreated samples and 45-57% for pretreated samples. These results showed that there was a little higher biodegradability observed in the samples without nitrate. Possibly DON was converted to NH_4^+ and subsequently transformed to nitrate by nitrifiers. This shows that DON can be another N source for the bacteria to use in the absence of nitrate. After the incubation, nitrate concentration increased because of nitrification. Ammonium and nitrite were not detected after the incubation. Rapid nitrate increase was observed in the first 10 days of 40-day incubation. Inorganic carbon concentration also decreased during the incubation, possibly used by nitrifiers.

Pehlivanoglu-Mantas and Sedlak (2008) investigated BDON in nitrified and denitrified wastewater effluent samples. The study concentrated on dissolved free amino acid (DFAA) and dissolved combined amino acid (DCAA). They concluded that typically 10-20% of the effluent DON is DFAA and DCAA. A small fraction of DON (< 10%) is

humic substances and ethylenediaminetetraacetic acid (EDTA). These substances are readily biodegradable during the treatment operation. Relatively low concentrations of DFAA and DCAA, which were observed after the incubation period, could be produced from DON during the biological activities.

2.3. Bioavailable Dissolved Organic Nitrogen

2.3.1. Definition of ABDON and its measurements

ABDON is a fraction of DON that is directly or indirectly (via biomineralization by bacteria) available as a nitrogen source for aquatic plant species (with algae being a test species). Determination of ABDON in wastewater effluent is important for controlling excess nutrient into an aquatic ecosystem. The bioavailability of DON in water environment depends on the environmental conditions such as residence time, temperature, DO level, pH, type of living organisms present, atmospheric light intensity, and light irradiation time. Most of the ABDON will be removed from the water ecosystem in time by algae, phytoplankton, and bacteria. However, excessive ABDON consumption could cause oxygen depletion and ultimately lead to eutrophication.

In order to determine effluent ABDON in the receiving waters, Pehlivanoglu and Sedlak (2004) conducted algal growth bioassay experiments using *Selenastrum capricornutum* as a seed on denitrified secondary effluent samples with a 2-week incubation period. *S. capricornutum* has been used as a standard eutrophication species for a long time and it is easy to culture in the laboratory. In their research, four inoculation and incubation conditions were examined: wastewater (WW) effluent + algae, WW effluent + algae + bacteria, WW effluent + algae + bacterial + nitrate, and deionized (DI) water + algae + bacteria + nitrate. Experiments with algae were incubated with a 12 h light/dark

cycle and the growth of algae was monitored by measuring chlorophyll a (chl-a) for 2 weeks. The bioavailability of DON was based on DON reduction (ABDON exertion) during the incubation. Results showed that treated effluent DON was not bioavailable to the algae in the absence of bacteria while about half of the effluent DON (56%) was bioavailable for algal uptake in the presence of bacteria. They concluded that the residence time of DON in receiving waters became important since DON was not readily bioavailable to algae.

A study was conducted by Urgan-Demirtas et al. (2008) to determine ABDON in denitrified effluent samples. Their experimental approach was similar to that of Pehlivanoglu and Sedlak (2004). The Printz Algal Assay Bottle Test, a U.S. EPA method, was adapted in their experiment to measure ABDON. The effluent samples were filtered through a 1.2 μm pore-size membrane filter. Experiments were divided into 8 conditions: 1) Algal inoculum + WW effluent, 2) Algal inoculum + algal medium, 3) Algal inoculum + algal medium + 1 mg/L nitrate, 4) Bacterial inoculum + WW effluent, 5) Algal inoculum + bacterial inoculum + WW effluent, 6) Bacterial inoculum + nitrogen limited algal medium (negative control), 7) WW effluent only (negative control), and 8) Algal inoculum without any inoculum (negative control). Experiments were conducted at 20°C and 50 rpm mixing with exposure to fluorescent light for all 14 days of incubation. In addition to ABDON, the following parameters were tested: $\text{NH}_4^+\text{-N}$, $\text{NO}_x\text{-N}$, TDN, DON, total carbon, inorganic carbon, DO, bacterial growth, and algal growth. A chl-a production method was used to measure algal growth. In the algae only seeded sample, approximately 0.4 mg N/L DON, which was 21% of initial DON in the sample, was bioavailable to algae

(*S. capricornutum*). For the algae + bacteria seeded sample, approximately 1.2 mg N/L DON, which was 63% of initial DON, was bioavailable to both species.

Urgun-Demirtas et al. (2008) also found that DON utilization by algae and algae + bacteria was the greatest during the first two days of the incubation. For the bacteria only seeded sample, the bioavailability of initial DON was found as 27%. Based on these results, they concluded that the amount of ABDON increased in the presence of bacteria. In addition, intermediates might be produced during the bacterial transformation of polymeric DON and these intermediates (such as amino acids and urea) might be taken up by algae. They suggested that their ABDON method can be also used at WWTPs with low TDN effluent.

2.3.2. Fate of ABDON in water environment

There has been no study available on ABDON in water environment. However, there have been some studies on wastewater effluent samples for predicting the fate of ABDON in receiving waters. Once wastewater effluent is discharged to receiving waters, it will likely be in contact with bacteria, algae, and/or phytoplankton.

An alga, *S. capricornutum*, was successfully used to determine ABDON in denitrified secondary effluent (Pehlivanoglu and Sedlak, 2004). Experiments were conducted in the presence and absence of bacteria during the incubation period, and chl-a production was measured to determine the amount of algal growth. In the first part of the experiments, three samples were prepared. The first sample was treated wastewater effluent sample (unamended sample), which initially contained 0.76 mg/L of DON, the second sample was DI with 1.0 mg N/L nitrate amended, and the third sample was treated wastewater effluent sample (containing 0.76 mg/L of DON) with 1.0 mg N/L nitrate

amended. Only algae were added to all these three samples without bacteria addition (absence of bacteria). Based on an 11-day incubation period, only small production of chl-a (about 20 chl-a) was observed in the wastewater samples. The nitrate amended DI water sample had about 550 chl-a increase while 400 chl-a was produced in the nitrate amended wastewater sample. The reason for less chl-a production in the nitrate amended wastewater sample compared to nitrate amended DI water sample could be antibacterial agents such as triclosan or phytotoxic compounds in the wastewater sample.

Pehlivanoglu and Sedlak (2004) also reported that after the incubation, about 40% DON reduction was observed in both unamended and nitrate amended wastewater samples. There was no inorganic nitrogen production in the unamended sample and chl-a production was low (about 20 chl-a). The reason for DON reduction could be some adsorption on the glass wall of container, or possible bacterial uptake, which existed in the system unconsciously. On the other hand, DON reduction in nitrate amended wastewater sample was explained as nitrogen uptake by algae only. Results from all three experiments proved that DON was not bioavailable to algae in the absence of bacteria (Pehlivanoglu and Sedlak, 2004).

The second part of the study by Pehlivanoglu and Sedlak (2004) was conducted with and without bacteria addition to the samples along with algae. Four sets of samples were prepared. The first one was wastewater with algae addition, the second sample was wastewater with both algae and bacteria addition, the third sample was wastewater with algae, bacteria and nitrate (0.25 mg N/L) additions, and finally the fourth sample was DI water with algae, bacteria and nitrate (0.25 mg N/L) additions. All these samples were incubated for 11 days. Significant algal growth was observed in the sample inoculated with

algae and bacteria (the second sample). The algal growth was very low in the treated effluent sample with seeded algae only. Approximately 56% (0.34 mg N/L) of DON in treated effluent sample was bioavailable to the algae in the presence of bacteria. ABDON in the wastewater effluent sample without the presence of bacteria was 0.10 mg N/L, which was fairly low.

Overall, Pehlivanoglu and Sedlak (2004) reported that a competition exists between algae and bacteria for nitrate when nitrate is the only nitrogen source in the system. Bacteria used nitrate to support growth and therefore, bioavailable nitrogen source for algae decreased. However, in the presence of both nitrate and DON in the system, bacteria increased the bioavailability of nitrogen to algae since bacteria metabolized DON to lower molecular weight compounds. It was concluded that the impact of bacteria on algal growth in wastewater effluent was crucial.

Urgun-Demirtas et al. (2008) investigated the bioavailability of wastewater derived DON to bacteria, algae (*S. capricornutum*), and bacteria and algae together. Samples were collected from a full nitrifying membrane bioreactor pilot plant (nitrification only), and a laboratory scale plant achieving low level of TDN using a nitrification/denitrification system. Some of the samples were amended with 1.0 mg/L nitrate for positive control experiments. A 14-day bioassay procedure was used. Results indicated that DON was bioavailable to algae after bacterial degradation and found that DON was even more bioavailable to algae in the presence of bacteria and algae together, simultaneously. While DON concentration decreased, biomass and chl-a concentration increased. Because of the low TDN concentration in the sample (low nutrient), DON concentration was fluctuating with incubation time during the experiments. However, nitrate amended samples showed a

more stable trend on DON concentration. DON consumption was rapid at the beginning of incubation indicating that DON was more bioavailable at the beginning. They explained that DON was uptaken or released by algae during the growth.

2.3.3. Fate of ABDON in wastewater treatment systems

Fate of ABDON in wastewater treatment systems has not been investigated. The studies by Pehlivanoglu and Sedlak (2004) and Urgun-Demirtas et al. (2008) described above only measured ABDON in the final effluent to determine the fate and behavior of algae in receiving waters. Similarly, Sattayatewa et al. (2009) conducted a study on ABDON using algae, bacteria, and algae + bacteria seeds in a 4-stage Bardenpho nitrogen removal plant. However, they concentrated on the final effluent only.

2.4. Photodegradable Dissolved Organic Nitrogen

2.4.1. Definition of PDON and its measurement

Photodegradable DON is a portion of DON that is decomposable by sunlight or artificial light to lower molecular weight organic compounds or inorganic nitrogen, which causes undesirable conditions in aquatic ecosystems by affecting bacterial growth, bacterial nutrient demand, bacterial biomass, and respiration rates in water body (Moran and Zepp, 1997; Bushaw-Newton and Moran, 1999; Bronk et al., 2010). Environmental factors, such as type and intensity of ultraviolet (UV) light, exposure time, temperature, pH, and initial DON concentration in the water body, are affecting the photodegradation efficiency of DON (Bushaw et al., 1996). Exposure to sunlight or artificial light causes DON to release ammonia (Bushaw et al., 1996; Moran and Zepp, 1997; Lomas et al., 2000; Koopmans and Bronk, 2002; Vähätalo and Zepp, 2005; Bronk et al., 2010), nitrite (Kieber et al., 1999; Bronk et al., 2010), urea and amino acids (Coffin 1989; Bushaw-

Newton and Moran, 1999; Koopmans and Bronk, 2002), dissolved primary amines (DPA) (Bushaw-Newton and Moran, 1999; Koopmans and Bronk, 2002), humic-associated nitrogen species (Bushaw et al., 1996) and unidentified organic nitrogen complexes.

PDON is determined from the difference in DON reduction during UV light experiments and dark incubation (control) as presented in Equation 2.4. UV light experiments are conducted using quartz containers, which allow more the majority of UV to penetrate. Control (dark) treatment was conducted using amber bottles. The control was treated exactly in the same manner as the light experiment but was kept in the dark for the entire experiment (Bushaw-Newton and Moran, 1999; Koopmans and Bronk, 2002).

$$\text{PDON} = (\text{DON}_i - \text{DON}_{\text{UV}}) - [(\text{DON}_i - (\text{DON}_{\text{dark}})]_{\text{control}} \quad (2.4)$$

where DON_i = initial DON (before UV light exposure)

DON_{UV} = DON after UV light exposure

DON_{dark} = DON after dark incubation.

2.4.2. Fate of PDON in water environment

Photochemical reactions increase the lability of organic material in marine and freshwater ecosystems by converting recalcitrant compounds into reactive materials and ultimately, these photoreactive organic compounds increase the bioavailable N in aquatic environment. Photochemical release of low molecular weight components and uncharacterized labile compounds causes undesirable conditions in aquatic ecosystems as mentioned above. Typically a fraction of effluent DON is recalcitrant against photodegradation. However, temperature and natural sunlight exposure time and its intensity affect the decomposition of DON in water ecosystems. Therefore, effluent DON

discharged to receiving waters can be productive downstream (Bushaw-Newton et al., 1999; Koopmans et al., 2002; Bronk et al., 2010).

Photochemical conversion of estuary DON in humic substances into biologically available components was studied (Bushaw et al., 1999). Samples were collected in August and February from the Skidaway River (Georgia) and in October from the Satilla River (Georgia). The samples were filtered through 0.2 μm pore-size filters. Light exposure, dark treatment, and bioassay experiments were applied to the samples. All the samples from both rivers were divided into 3 portions prior to light irradiation, dark, and bioassay experiments. The first set of samples was amended with humic substances, the second set was not amended (control) and third set was amended with 16 μM N as NH_4NO_3 . Seven hours of irradiation were applied to all three sets of samples and then the samples were seeded with bacteria and incubated for five days. The bacterial inoculum was obtained from a natural bacterioplankton community from the same sites that the samples were collected. For the dark experiment, all three sets of samples were incubated directly (no light exposure and no seed addition) for five days. Temperature was kept at 10°C during the light, dark control, and bioassay experiments.

Results from the study conducted by Bushaw et al. (1999) showed that ammonium and DPA production from humic substances was not observed in the August Skidaway River samples; however, net production in ammonium and DPA from humic substances was observed for the February Skidaway River and October Satilla River samples. It should be noted that DPA production was not detectible in the less concentrated February Skidaway River sample, but was observed in the more concentrated sample. Bioassay results showed that ammonium and DPA, which were released from humic substances,

enhanced the cell accumulation in the February and October humic amended samples. The cell accumulation proved that humic substances produced a low-molecular weight photolabile compounds (which were ammonium and DPA in this case) during the exposure of sunlight. For the control samples, there was no bacterial growth. Bacterial growth was not also observed in the nutrient (NH_3 and NO_3) added irradiated sample and dark sample. It was concluded that humic substances released biologically available products during the irradiation. It was estimated that 1 to 2% of the humic associated DON was converted to ammonium and/or DPA, during the 7 hour incubation.

Vähätalo and Järvinen (2007) investigated photoproduction of bioavailable nitrogen from biologically recalcitrant DON. Prior to UV light exposure, they applied pretreatment to their sea water samples to remove bioavailable nitrogen using nanoplankton culture under photosynthetically active radiation (PAR) light for 6-day of incubation. After the pretreatment, they applied solar radiation to the samples for 19 days. After solar irradiation, they applied a 12-day bioassay procedure using a nanoplankton culture under PAR light to determine bioavailable nitrogen exerted from DON during the solar irradiation. They concluded that photochemical reactions produced about 14% bioavailable nitrogen from biologically recalcitrant DON.

Vähätalo et al. (2011) produced labile compounds from photochemical transformation of DOM to support nitrogen limited heterotrophic and autotrophic plankton community in water samples, which were collected from 42 m deep from the coastal northern Baltic Sea. Their experiments were divided into three steps : 1) Applying pretreatment on the samples to remove bioavailable N, 2) Applying 12 days of light exposure (typical daily dose of solar radiation) on the pretreated sample (from step 1) to

generate photoproducted DOM, and 3) Applying 10 days of a bioassay procedure on photoproducted DOM to monitor the growth of heterotrophic and autotrophic plankton community. Dark treatment was also carried out along with the light experiment for control. After the pretreatment, samples were transferred to quartz and glass bottles for the light and dark experiments, respectively. The bioassay procedure was applied to all the samples right after light exposure and dark treatment. During the bioassay, samples were inoculated with an indigenous plankton community. Results showed that light exposure of DOM increased the biomass (chl a) of heterotrophic bacteria, flagellates, and ciliates during the bioassay procedure. However, during the light irradiation the biomass of phytoplankton and heterotrophic flagellates remained the same but bacterial regrowth was observed. Bacterial production was $1.1 \mu\text{mol C L}^{-1}$ higher after light exposure compared to the dark control, and after bioassay, bacterial production was $4.4 \mu\text{mol C L}^{-1}$ higher for light exposed samples than for dark control samples. Ammonium production was negligible after both the light exposure and dark control treatments.

Bronk et al. (2010) investigated photochemical release and subsequent PDON production of effluent organic nitrogen (EON) from two ENR WWTPs. The ENR facilities were selected because of high percent of DON production relative to DIN in the effluent samples. Grab samples of the effluent prior to UV disinfection were collected from two WWTPs and were named as EON4 and EON5. Both samples were filtered through a $0.2 \mu\text{m}$ pore-size cartridge filter to remove microbial cells from the samples. The filtered wastewater samples were concentrated and added into river water samples to simulate natural aquatic conditions. EON4 samples were concentrated from 13 L to 270 mL, and EON5 samples were concentrated from 19 L to 405 mL using a rotary evaporator. EON4

was 427 $\mu\text{g N/L}$, which was made up of 56% DON, 43% NO_3^- , 0.3% NH_4^+ , and 0.3% nitrite (NO_2^-). EON5 was 369 $\mu\text{g N/L}$, which consisted of 97.5% DON, 0.7% NO_3^- , 0.5% NH_4^+ , and 1.3% NO_2^- . The samples were exposed to natural sunlight for 0 (control), 9, and 33 hours. Results showed that significant photoproduction of NH_4^+ and DPA were observed from both EON4 and EON5 samples, but NO_2^- release was observed only in EON4 samples.

2.4.3. Fate of PDON in wastewater treatment systems

There has been no investigation on the fate of PDON in wastewater treatment systems. The study by Bronk et al. (2010) reviewed above only measured PDON in the final effluent. The study did not determine if any portion of PDON was also biodegradable or not.

CHAPTER 3. IMPACT OF SOLIDS RETENTION TIME ON DISSOLVED ORGANIC NITROGEN AND ITS BIODEGRADABILITY IN TREATED WASTEWATER

3.1. Introduction

Dissolved organic nitrogen constitutes about 25-80% of TDN in the final effluent of WWTPs (Pehlivanoglu-Mantas and Sedlak, 2006; Sattayatewa et al., 2009; Simsek et al., 2012). Effluent DON can be biodegraded to lower molecular weight compounds such as urea, free amino acids, nucleic acids and several uncharacterized labile compounds under certain environmental conditions and eventually ammonia. BDON is defined as a fraction of DON that can be ammonified by bacteria (Parkin and McCarty, 1981a; Khan et al., 2009; Simsek et al., 2012). High level of DON in surface waters stimulates algal growth and depletes oxygen if it undergoes ammonification and nitrification. Low DO in water bodies affects aquatic life critically by causing hypoxia and is linked to eutrophication in estuaries, lakes, and coastal waters.

WWTPs are one of the main nitrogen suppliers to surface waters. However, there have been limited studies on biodegradability of effluent DON. In the past, removing only ammonia-nitrogen was essential for WWTPs to reduce its toxicity to aquatic organisms. DON in the effluent was not considered as a nutrient source since it was refractory to treatment processes (Bronk et al., 2010). Current technologies in advanced wastewater treatment processes can achieve more than 95% of inorganic nitrogen removal and the remaining nitrogen in the effluent mainly consists of DON. With more and more stringent regulation in TN discharge limit, it is imperative to minimize effluent DON in order to be in compliance.

Chemical composition of effluent DON varies with the influent wastewater characteristics and bacterial activity in the treatment system (Parkin and McCarty, 1981a; Pehlivanoglu-Mantas et al., 2008; Pagilla et al., 2011). Pagilla et al. (2011) conducted laboratory scale sequencing batch reactor (SBR) activated sludge process experiments to investigate the effect of influent nitrogen composition on microbial DON production. Three different synthetic wastewater samples were prepared in different nitrogen compositions (nitroacetic acid + ammonium, ammonium only, and amino acid mixture + ammonium). They observed about 1-2 mg/L DON production in the effluent even though there was no organic nitrogen introduced in the influent feed solution (ammonia only feed) of the reactor. The nitrifier growth rate constant in the system was the highest (between 0.91 and 1.14 day⁻¹) and lowest (0.82 day⁻¹) for the influent samples contained nitroacetic acid + ammonium, and ammonium only, respectively. On the contrary to their full-scale plant observations, Pagilla et al. (2011) found very little (negligible) colloidal organic nitrogen (CON) in the effluent of the SBR. They explained that partial breakdown of influent suspended solids in full-scale plants could be the source of effluent CON.

Sattayatewa et al. (2009) investigated the biodegradability and bioavailability of the effluent DON from a 4-stage Bardenpho process in the presence and absence of nitrate. They inoculated the samples with either mixed culture bacteria (from MLSS) or algae and bacteria together. The incubation period was 40 days for BDON (bacteria only seed) and 14 days for algae-bacteria seeded samples. Effluent DON bioavailability for three algae-bacteria seeded samples in the presence of nitrate was 40%, 34%, and 28% and it was higher when DON was the only nitrogen sources (nitrate absence by ion exchange pretreatment), which was 48%, 57%, and 35%. Effluent DON bioavailability for bacteria

only seeded samples was 41%, 42%, and 43% in the presence of nitrate, and 46%, 57%, and 45% in the absence of nitrate. They concluded that DON can be an alternative nitrogen source in the absence of nitrate. There was no difference between bacteria seeds and algae-bacteria seeds with respect to amount of DON utilization.

Khan et al. (2009) developed a procedure that can be routinely used at wastewater utilities for quantifying BDON in treated effluent. The BDON procedure adopts the concepts of two existing bioassay methods in the wastewater field, BOD and biodegradable dissolved organic carbon. The procedure is based on DON reduction during incubation and relies on the use of a mixed culture inoculum, which is agreeable with treatment plant conditions. An acclimated MLSS inoculum and an incubation period of 20 days were found to be adequate for BDON exertion. The procedure provided reliable BDON results for standard samples with DON greater than 0.40 mg N/L with an average detection limit of 0.31 mg N/L.

The availability of the BDON procedure (Khan et al., 2009) allows the nutrient removal field to move forward in answering the most practical and vital question regarding the biodegradability of DON. What is a way to minimize effluent BDON or DON biodegradability? SRT, the main control parameter for activated sludge process, is known to affect effluent quality particularly collective organic parameters such as BOD and chemical oxygen demand (COD). However, the effects of SRT on effluent DON and BDON are not known.

The objective of this study is to investigate whether effluent DON, BDON, BDON/DON can be minimized by SRT. Laboratory scale chemostat experiments were conducted to examine the effects of SRT (same as hydraulic retention time for chemostat

reactors) on the concentrations of DON and BDON in treated wastewater. Actual primary treated wastewater was used to feed the chemostat reactor which was operated at different SRTs ranging from 0.3 to 13 days. All major dissolved inorganic nitrogen species and TDN, soluble COD (SCOD), and soluble BOD at 5 days (SBOD₅) concentrations were measured continuously for the chemostat influent and effluent samples. DON and BDON for the chemostat influent and effluent samples were determined from the TDN and dissolved inorganic nitrogen species data.

3.2. Materials and Methods

3.2.1. Sample source, preparation, and storage

Primary treated wastewater was collected (grab sample) from the Moorhead WWTP (Moorhead, MN, USA) and was used as influent for a chemostat reactor. This facility uses a high purity oxygen activated sludge (HPO-AS) process with a SRT of 3 days for biological treatment and has a treatment capacity of 4 million gallons per day (MGD). A portion of the primary treated wastewater (about 5 gallons) was placed in a refrigerator (at 4°C) within 20 minutes after the collection and used to feed the chemostat reactor. The rest of the wastewater was stored in another refrigerator at 4°C for future use within 3-4 days.

The chemostat reactor was seeded with MLSS taken from an aeration tank of the same facility at the beginning of each SRT studied. Also, MLSS was used to seed BOD and BDON samples. Instead of going to the treatment plant daily to obtain fresh MLSS for seeding, 2 L of MLSS were placed in a container and was aerated and fed with primary wastewater daily. Every 3-4 days, this MLSS was discarded and a fresh MLSS was obtained from the treatment plant.

3.2.2. Experimental setup and operation

The chemostat reactor was made of plexiglass. The working volume of the reactor was 10 L with a height of 17 cm, a width of 20 cm, and a length of 30 cm. The reactor was operated at a constant temperature of 25°C (room temperature). At the beginning of the chemostat operation, 5 L of sample and 5 L of fresh MLSS were used to fill the reactor. Immediately after, the influent (primary treated wastewater) is fed to the inlet of the reactor using a peristaltic pump (Masterflex L/S, Cole-Parmer, USA).

The peristaltic pump was calibrated for a desired flow rate prior to the experiment and it was checked and adjusted daily to maintain the same flow rate. Continuous and uniform aeration was provided with bubble diffusing stones to achieve complete mixing. Air flow rate was regulated to maintain a minimum DO level of 5.0 mg/L. The chemostat reactor was operated at 9 different SRTs of 0.3, 0.7, 2, 3, 4, 5, 7, 8, and 13 days. SRTs of 2 to 13 days are typical for activated sludge WWTPs (Metcalf & Eddy, 2003). Less than 3-day SRTs (0.3- and 0.7-day SRTs) were studied to observe the cell wash-out.

3.2.3. Parameters studied and sampling program

Immediately after the beginning of the experiments, MLSS and influent sample were characterized for SCOD, SBOD₅, and dissolved nitrogen species (ammonia, nitrite, and nitrate, total nitrogen). Effluent sample collection began on the second day of the chemostat operation and continued until the end of the reactor operation for each SRT. The same parameters listed above were tested daily for the effluent of the reactor. However, only the data collected after steady-state conditions are reported in this study. Once the steady state condition was achieved the system, the reactor was operated for at least 5 days to complete the data collection. Steady state condition was considered to be achieved when

the daily variations of effluent quality (SCOD, SBOD₅, and N species) along with biomass (volatile suspended solids) concentration were less than 10% for 5 consecutive days. DO and pH were also monitored continuously to ensure a livable environment for the microorganisms. A 250 mL grab effluent sample was collected daily from the reactor effluent. About 50 mL of this sample were used for the analyses of the above parameters, and the remaining 200 mL of sample were used for BDON analysis.

3.2.4. DON and BDON determination procedures

In this study, DON was determined from the difference between measured TDN and measured DIN species using Equation 2.1 and following the procedure described in Section 2.1.1. BDON was determined using the procedure developed by Khan et al. (2009) with slight modifications (Section 2.2.1 and Figure 2.1). A 20-day incubation period and a MLSS seed were used in the BDON procedure by Khan et al. (2009). However, a 28-day incubation period and diluted MLSS (10 fold dilution of approximately 2,500 mg suspended solids/L) were used in this study. The reason for choosing 28 days for incubation is to further ensure that time was not a limiting factor for ammonification of DON in the sample.

The details of the BDON procedure used are as follows. The samples were filtered through a 1.2 mm pore-size Whatman glass microfiber filter (Whatman Inc., Kent, UK). A portion of the filtered sample was used for immediate analysis of TDN and inorganic nitrogen species (ammonia, nitrite, and nitrate). DON was determined and the value was recorded as initial DON (DON_i). Two hundred milliliters of the remaining filtered sample were mixed with 2 mL of acclimated inoculum (diluted MLSS) in a 250 mL amber bottle. The solution in the bottle was shaken thoroughly to aerate and placed in an incubator in the

dark at 20°C for 28 days. During the incubation period, on a daily basis, the sample in the bottle was manually and gently shaken for several minutes while the cap was opened. After the gently shaking, the cap was closed and the bottle was shaken vigorously to mix the sample with fresh air in the headspace. These shaking practices were for sample re-aeration to maintain aerobic conditions. A seed control (sample b), which was treated the same way as the samples, was prepared by adding the inoculum to 200 mL of DDW (DON_{bi} and DON_{bf}). After 28 days of incubation, all nitrogen species in the supernatant were measured to determine final DON (DON_{f}). BDON was calculated according to Equation 2.3.

3.2.5. Analytical methods

All the parameters were determined in duplicate or triplicate and average values were reported. All the samples were filtered through a GF/C filter. All the glassware was washed with soap, rinsed with tap water, kept in a 5% v/v hydrochloric acid bath overnight and rinsed with DDW and then autoclaved before use. SBOD_5 , SCOD, and volatile and total suspended solids were analyzed according to Standard Methods (APHA et al., 1998). MLSS inoculum was used as a seed for SBOD_5 measurement. A high range COD kit (0-1500 mg/L) from Hach Company (Loveland, CO, USA) was used for SCOD measurement.

The salicylate methods (Hach method # 10023 and #10031) were used for ammonia nitrogen measurement. Method # 10023 was used for values ranging between 0.02 and 2.50 mg/L while method # 10031 was applied for values ranging between 0.4 and 50.0 mg/L. The Test 'N Tube AmverTM test kits and a Hach DR 5000 spectrophotometer at 655 nm were used.

The diazotization method (Hach method # 10019) was used for low range nitrite nitrogen measurement (between 0.003 and 0.500 mg/L as NO_2^- -N). The Test 'N Tube

NitriVer®3 test kits and a Hach DR 5000 spectrophotometer at 507 nm were used. The ferrous sulfate method (Hach method #8153) was used for high range nitrite measurement (between 2.0 and 250.0 mg/L as NO_2^- -N). The NitriVer®2 Nitrite Reagent powder pillows and Hach DR 5000 spectrophotometer at 373 nm were used.

Dissolved nitrate was measured by a second derivative UV spectrophotometric (SDUS) method (APHA et al., 2005). The method was used for nitrate values ranging between 0.0 and 3.0 mg/L as N. Samples with higher nitrate concentrations were diluted to the measureable range. A Varian Cary 50 UV-V spectrophotometer was used with a quartz cuvette.

TDN was measured by the SDUS method (APHA et al., 2005) after modified persulfate digestion (Sattayatewa and Pagilla, 2008). The method was used for TDN values ranging between 0.0 and 3.0 mg/L as N. Samples with higher TDN concentrations were diluted to the measureable range. During the digestion, all nitrogen species (dissolved inorganic and organic) in the sample are converted to nitrate.

3.2.6. Statistical analyses

Two-way analysis of variance (ANOVA) using General Linear Models (GLM) procedure (SAS version 9.2; SAS Institute, Cary, NC) was conducted to determine the statistical differences in effluent DON and BDON and DON degradability (BDON to DON ratio) provided by different SRTs.

3.3. Results and Discussion

3.3.1. SBOD₅ and SCOD profiles

Influent and effluent SBOD₅ of the chemostat reactor are presented in Figure 3.1a for 9 different SRTs. The data represent the average values during the steady state and

standard deviations. It should be noted that standard deviations for some data points could not be seen because they are very small and in turn are within the data legend. Average influent SBOD₅ concentration ranged from 106 mg/L to 190 mg/L. The SBOD₅ removal efficiency was low at SRT of 0.3 and 0.7 day (about 37% and 57%) while it was high (between 84% and 94%) for the higher SRTs. The highest SBOD₅ removal efficiency was

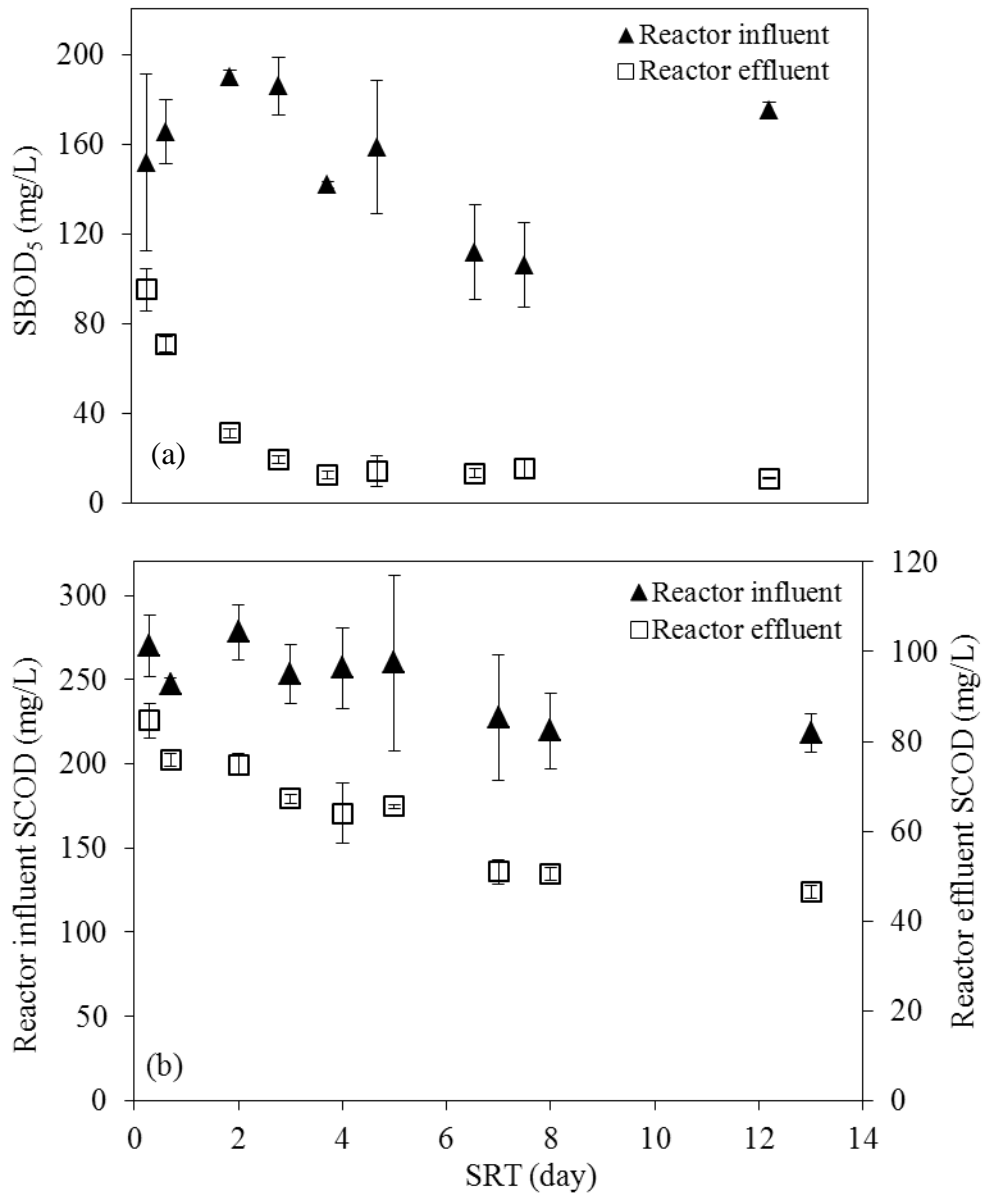

Figure 3.1. (a) Influent and effluent SBOD₅ and (b) Influent and effluent SCOD of chemostat reactor at different SRTs.

observed at 13-day SRT (94%). The effluent SBOD₅ tended to decrease with SRT as theoretically known.

The SCOD profile also followed the same trend as the SBOD₅ profile (Figure 3.1b). The influent SCOD concentration fluctuated more while the effluent concentration tended to decrease with SRT but not as dramatically and consistently as the effluent SBOD₅ profile. The lowest effluent SCOD concentration was observed as 46.5 mg/L at 13-day SRT with a removal efficiency of 81%.

3.3.2. NH₃-N, NO₂-N, NO₃-N, and TDN profiles

The NH₃-N profiles (Figure 3.2a) suggest that there was limited nitrification at the two lowest SRTs (0.3 and 0.7 days). Full nitrification of NH₃-N occurred at SRTs of 2 days and longer. Also, NH₃-N including that from ammonified DON was completely nitrified during the BDON incubation process for all 9 SRTs.

Influent NO₂-N concentrations were always low (< 0.02 mg/L) for the entire experiments. Reactor effluent NO₂-N values varied from 0.2 to 0.8 mg/L for all SRTs tested (Figure 3.2b). The nitrite was completely nitrified to nitrate during the BDON incubation. Figure 3.2c., which presents the effluent NO₃-N and NO₃-N profiles after the BDON incubation, supports the discussion on the level of nitrification that took place in the chemostat reactor and during the BDON incubation. NO₃-N concentrations before and after the incubation were close except for the first two SRTs (0.3 and 0.7 days of SRT). The chemostat reactor was able to nitrify at relatively low SRTs (2 to 5 days) because the mixed liquor used to seed the reactor was taken from the aeration tank that received the recycled flow of anaerobic digester supernatant known to contain nitrifiers. About 20% of NH₃-N are nitrified to NO₃-N in this aeration tank although its SRT is only 3 days. It is

possible that seeding the chemostat with this mixed liquor and operating at SRTs that were not short enough led to retention of nitrifiers and nitrification.

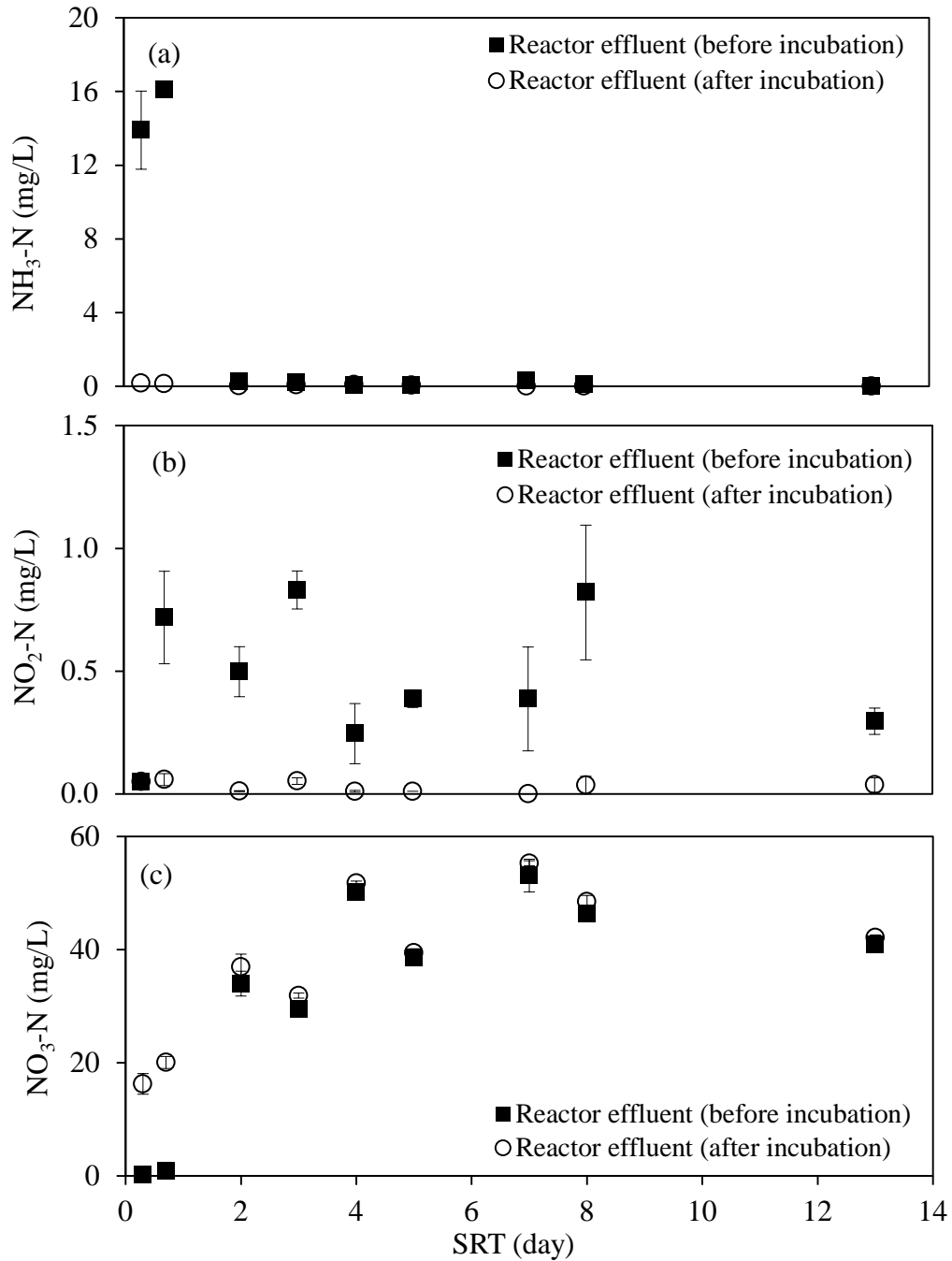

Figure 3.2. (a) $\text{NH}_3\text{-N}$, (b) $\text{NO}_2\text{-N}$, and (c) $\text{NO}_3\text{-N}$ of chemostat reactor effluent before and after BDON incubation at different SRTs.

The TDN profiles for chemostat influent and effluent and TDN after the BDON incubation are presented in Figure 3.3. The influent TDN varied between 27 mg/L and 59 mg/L. The reduction in TDN in the chemostat reactor for the first 6 SRTs are probably due to more N uptake for cell synthesis and less endogenous respiration (cell lysis). Higher effluent TDN compared to influent TDN at SRTs of 7, 8, and 13 days was likely due to the dominance of endogenous respiration over N uptake. Comparable values for effluent TDN and TDN after incubation indicated N balance throughout the BDON incubation process.

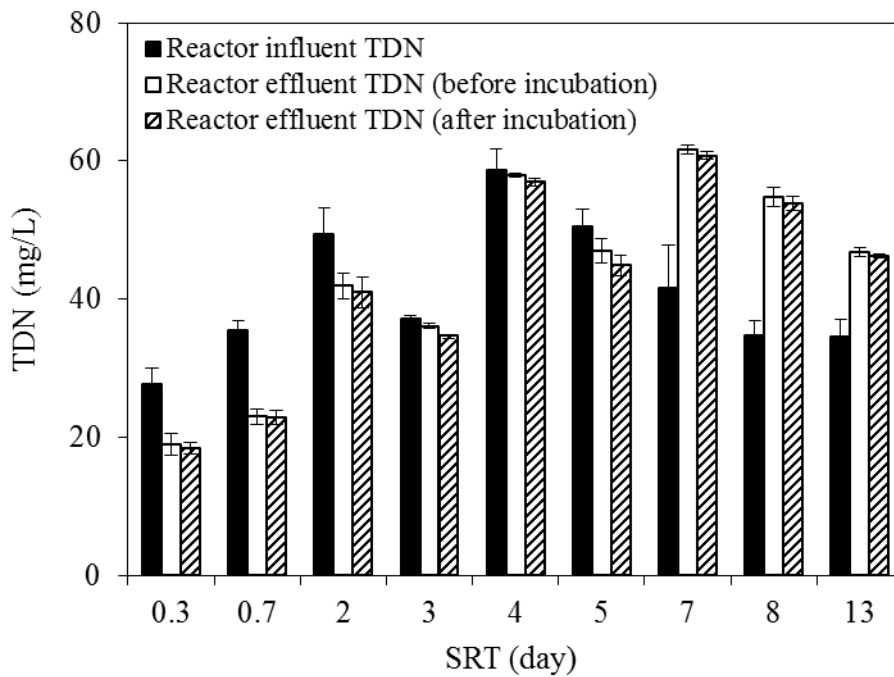

Figure 3.3. TDN of chemostat reactor influent and TDN of chemostat reactor effluent before and after BDON incubation at different SRTs.

3.3.3. DON, BDON, effluent BDON/effluent DON, and effluent DON/effluent TDN profiles

Effluent DON and BDON of the chemostat and DON after incubation at different SRTs are presented in Figure 3.4a. There was no trend between effluent DON and SRTs. The minimum and maximum effluent DON values were 4.75 mg/L (at SRT of 0.3 day) and

8.08 mg/L (at SRT of 4 days), respectively. DON after incubation also exhibited no trend with SRTs.

Effluent BDON is approximately equal to the difference between effluent DON (DON before incubation) and DON after incubation. The minimum and maximum effluent BDON concentrations were 1.77 mg/L (at SRT of 13 days) and 3.13 mg/L (at SRT of 2 days), respectively. Effluent BDON was comparable for SRTs of 0.3 to 4 days and tended to gradually decrease between SRTs of 4 days and 13 days. The magnitudes of DON and BDON observed in this study are much higher than those reported in previous studies (Murthy et al., 2006; Khan et al., 2009). However, the effluent samples examined in both previous studies were from biological nutrient removal wastewater treatment plants operated at high SRTs (> 10 days). The lack of trend or consistent trend between effluent DON and BDON and SRTs could be the fluctuation in influent nitrogen concentration. However, when effluent BDON/effluent DON was plotted against SRT (Figure 3.4b), a more conclusive trend is observed.

Effluent BDON/effluent DON (effluent DON biodegradability) decreased with SRT until SRT of 8 days and a minute increase was observed in the last SRT. Two-way ANOVA results suggest two groups of data, SRTs of 0.3 to 5 days and 7 to 13 days. Effluent DON biodegradability was not statistically different within each group ($p > 0.05$) but was significantly different between the two groups ($p < 0.05$). Although these statistical results are not as compelling as the graphical results (Figure 3.4b), they also support the benefit of operating at higher SRTs in term of less effluent DON biodegradability. The range of effluent DON biodegradability (23 to 59%) observed in this

study is agreeable with the values previously reported by Murthy et al. (2006), Khan et al. (2009), Sattayatewa et al. (2009), and Simsek et al. (2012).

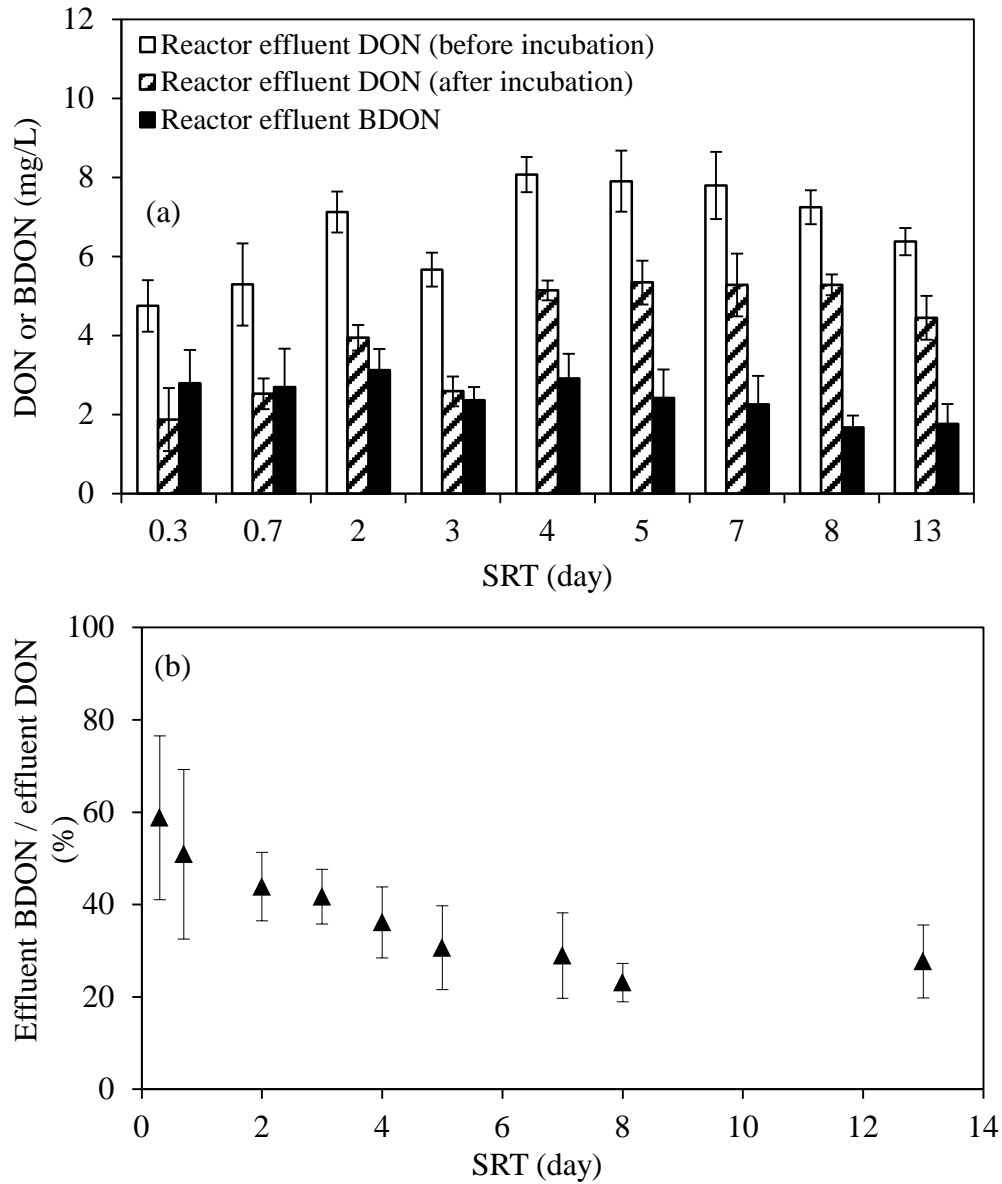

Figure 3.4. (a) Effluent DON before and after incubation and effluent BDON of chemostat reactor at different SRTs, (b) Effluent BDON/effluent DON of chemostat reactor at different SRTs.

Figure 3.5 shows effluent DON to effluent TDN ratio before and after the incubation. Operating at higher SRTs produced less DON fraction in TDN for the range of SRTs of 0.3 to 7 days. This benefit is not evident at SRTs of 7 to 13 days. After the

incubation, effluent DON to effluent TDN ratio fluctuated in a narrow range (8 to 12%) and statistically the values are not significantly different ($p < 0.01$) for all SRTs studied.

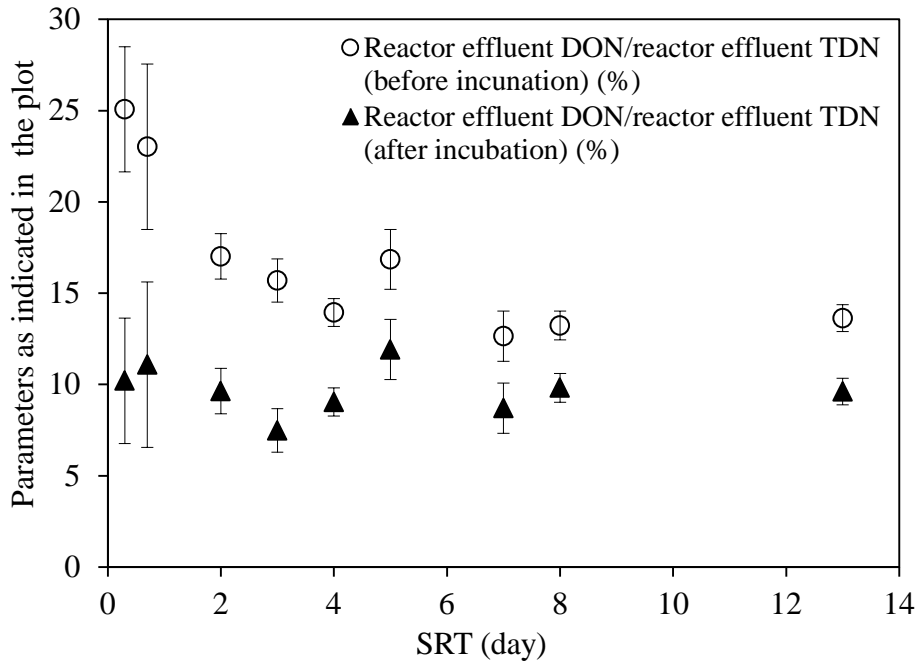

Figure 3.5. Effluent DON/effluent TDN before and after incubation of chemostat reactor at different SRTs.

The results suggest that providing long enough time such as that in the BDON incubation DON will be ammonified to a threshold level that only recalcitrant DON remains in the sample. That threshold level is about 10% (DON:TDN) for the wastewater used in this study. The comparison between the two data sets (before and after the incubation) confirms the benefit of operating at higher SRTs in term of effluent DON fraction being closer to the recalcitrant fraction.

3.4. Summary

Laboratory scale chemostat experiments were conducted to examine the effects of SRT (0.3 to 13 days) on the concentrations of DON and BDON in treated effluent. There was no significant trend observed between effluent DON and SRTs. However, effluent BDON was comparable for SRTs of 0.3 to 4 days and gradually decreased between SRTs

of 4 days and 13 days. Effluent BDON concentrations varied between 1.77 and 3.13 mg/L for all 9 SRTs. A more conclusive trend was observed for effluent BDON to effluent DON ratio (effluent DON biodegradability) versus SRT. Effluent DON biodegradability generally decreased with SRT. Minimum and maximum effluent DON biodegradability were 23% (at 8-day SRT) and 59% (at 0.3-day SRT), respectively. Operating the chemostat reactor at SRT of 7 days and above resulted in effluent DON that is close to the bioreclacitrant level which is based on DON concentration observed in the sample after a 28-day of incubation process for BDON determination. The results from this study suggest opeating at higher SRTs reduces not only effluent orgnamic carbon in terms of oxygen demands but also effluent BDON and DON biodegradability, and fraction of DON in effluent TDN.

CHAPTER 4. FATE OF DISSOLVED ORGANIC NITROGEN IN TWO STAGE TRICKLING FILTER PROCESS

4.1. Introduction

Availability of excess nutrients is known to cause eutrophication of water bodies such as lakes and rivers, which leads to low dissolved oxygen conditions and eventually makes the water body unsuitable for recreational purposes (Carlsson et al., 1999; Filippino et al., 2011). DON is one of the primary nutrients causing low DO conditions, with discharges from WWTPs being one of the major contributors (Pehlivanoglu and Sedlak, 2004; Bronk et al., 2010; Pagilla et al., 2011). DON consists of urea, amino acids, nucleic acids, proteins, humic substances and a variety of uncharacterized compounds (Bushaw et al., 1996; Berman and Bronk, 2003; Pehlivanoglu-Mantas and Sedlak, 2008).

DON in receiving waters originates from natural and anthropogenic sources, including agricultural runoff, atmospheric deposition, intensive farming, wetlands, and effluent from WWTPs (Seitzinger and Sanders, 1997, 1999; Pehlivanoglu and Sedlak, 2004; Seitzinger et al., 2005; Pehlivanoglu-Mantas and Sedlak, 2006, 2008; Urgun-Demirtas et al., 2008). Effluent DON contains about 10-20% of DFAA and DCAA and about 5% of EDTA. In addition, about 10% of wastewater derived DON consists of humic substances originating from drinking water. About 70% of the wastewater derived DON still cannot be characterized with currently available methods (Pehlivanoglu-Mantas and Sedlak, 2006, 2008).

Due to recent advances in treatment processes, WWTPs equipped with nitrification and denitrification processes are able to achieve more than 95% removal of DIN. Most of the WWTPs equipped with these advanced processes discharge effluent TDN of 10 mg/L

or less (Pehlivanoglu-Mantas and Sedlak, 2006; Urgun-Demirtras et al., 2008; Sattayatewa et al., 2009). Recent studies indicate that a major portion of the wastewater effluent TDN is generally in organic form, DON, ranging from 25% to 80% of the effluent TDN (Pehlivanoglu-Mantas and Sedlak, 2006; Sattayatewa et al., 2009). DON concentration in secondary treated effluent typically ranges from 1 to 5 mg N/L. Since high DIN removal has been achievable using the best available technologies, the future target for the treatment plants to reach increasingly stringent regulations for receiving water quality protection will be the removal of DON. For impaired receiving waters, the TN limit for WWTP effluent discharges could be as low as 3 mg/L or less (WERF, 2009).

Although effluent DON is recalcitrant to the current treatment processes, studies showed that about 50% of the effluent DON is bioavailable or biodegradable to algae and/or bacteria in long period incubation tests (2 to 6 weeks) (Murthy et al., 2006; Pehlivanoglu-Mantas and Sedlak, 2006; Khan et al., 2009; Sattayatewa et al., 2009). Bioavailable DON is the portion of DON that can support the growth of algae and/or bacteria (Pehlivanoglu and Sedlak, 2004; Urgun-Demirtras et al., 2008), while BDON is the portion of DON that can be mineralized by an acclimated mixed bacterial culture (Khan et al., 2009). BDON in denitrified effluent from four different WWTPs in Washington, D.C. and Virginia was about 25% to 33% of DON (Murthy et al., 2006). All four plants employ biological nutrient removal suspended growth systems. In batch assays conducted by Sattayatewa et al. (2009), BDON was 57% of the effluent DON for a 4-stage Bardenpho nutrient removal plant.

Due to a long incubation period (28 days) associated with the BDON procedure (Khan et al., 2009), it is not possible for the treatment plants to make timely operational

adjustments to efficiently remove DON, which could lead to a possible permit violation. Modeling WWTP processes to predict DON and BDON profiles could be a helpful approach in this case. Limited work has been done on modeling the fate of DON and BDON through wastewater treatment plants. Makinia et al. (2011) attempted to model the fate of particulate organic nitrogen (PON), CON and DON in an activated sludge wastewater treatment plant. A modified Activated Sludge Model No. 2d (ASM2d) (Henze et al., 1999) was used in their study by including these three forms of organic nitrogen. The new model incorporated hydrolysis of PON and CON to DON and ammonification of DON in all three environmental conditions (aerobic, anaerobic, and anoxic).

The fate of DON and BDON in WWTPs has gained attention in recent years. However, there has been no report on effluent DON and BDON from treatment plants using trickling filters since the process is less common in wastewater utilities. The objectives of this study were to investigate the fate of DON and BDON in a WWTP with a two-stage trickling filter process and to simulate DON and BDON profiles through the trickling filter treatment plant. The Fargo WWTP, Fargo, North Dakota was used as a model treatment plant. To simulate DON and BDON profiles, the trickling filter treatment plant was modeled using BioWin® version 3.1 (Envirosim Associates, Ltd.). The model was calibrated to match the simulated with measured values. A sensitivity analysis was performed to evaluate the extent to which the parameters used in the model calibration influence the model outputs. Plant operational data and measured dissolved nitrogen species (ammonia, nitrite, nitrate, DON, and BDON) were used for the model setup, calibration and verification purposes.

4.2. Material and Methods

4.2.1. Description of the Fargo WWTP, and sample collection and preparation

The Fargo WWTP has a two-stage trickling filter process with a peak pumping capacity of 29 MGD and an average flow of 11-15 MGD. A simplified schematic diagram of the treatment plant is shown in Figure 4.1. The facility consists of an influent pumping station, screening, grit removal, two pre-aeration channels, seven primary clarifiers, three BOD trickling filters, two intermediate clarifiers, two nitrification trickling filters, one final clarifier, chlorination, and dechlorination units. The plant is not subject to fecal coliform regulations during the winter months; hence the chlorination and dechlorination were not practiced during that period. The treated wastewater from the plant is discharged continuously by gravity flow to the Red River. However, in emergency situations such as during high river stage or when water quality does not meet North Dakota State discharge standards, the treated water is pumped from the plant to nearby stabilization ponds. The treated water is stored in these ponds until it can be discharged into the Red River.

Grab samples were collected from eight different locations along the treatment train in the plant. Sample identification and collection locations are shown in Figure 4.1. Sampling was conducted bi-weekly between August 2009 and July 2010. It should be noted that some of the sampling schedules were skipped due to severe weather conditions resulting a total of 18 samples, 8 samples in winter (November to March) and 10 samples in summer (April to October). Three hundred milliliters of each sample was filtered through a 0.2 μm pore-size cellulose acetate membrane filter (Whatman Inc., Kent, UK) within an hour after collection and used for determining dissolved nitrogen species (ammonia, nitrite, and nitrate, total nitrogen), DON, and BDON. Samples collected from

locations 1 and 2 were filtered through a 1.2 μm -pore size glass microfiber filter (Whatman Inc., Kent, UK) before the filtration through the 0.2 μm pore-size filter due to higher solid concentrations.

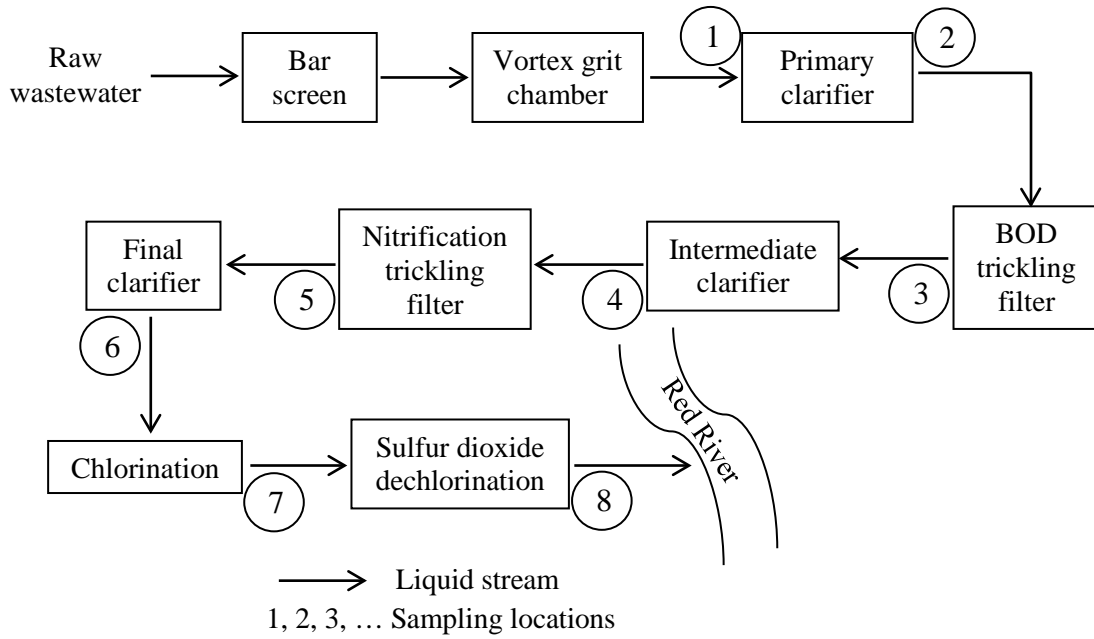

Figure 4.1. A simplified schematic diagram of the Fargo WWTP.

4.2.2. DON and BDON determination procedures

In this chapter, DON and BDON were determined as explained in Section 3.2.4. Both MLSS and raw wastewater seeds were experimented with the first few sets of samples and similar results were obtained. Raw wastewater seed was chosen to be consistent with the treatment plant that uses it for regular BOD measurement.

4.2.3. Modeling strategy

BioWin version 3.1 (EnviroSim Associates Ltd., Canada) was used to simulate DON conversion in the Fargo wastewater treatment processes. Influent fractionation was performed using historical plant data. A sensitivity analysis was performed to identify the

most influential calibration parameters. The model was calibrated using a dataset obtained in this study. It should be noted that only a steady state calibration was performed.

4.2.3.1. Model description

The software uses a general activated sludge/anaerobic digestion model (ASDM) (Jones and Takacs, 2004). The ASDM model comprises 50 state variables and 60 process expressions. These expressions are used to describe the biological processes occurring in activated sludge and anaerobic digestion systems, several chemical precipitation reactions, and gas-liquid mass transfer for six gases. BioWin uses a modified 1D biofilm model (Takacs et al., 2007) that is integrated with the ASDM model. Biofilm thickness growth is influenced by attachment and detachment processes.

DON in BioWin is modeled as illustrated in Figure 4.2. The model includes biomass decay, hydrolysis of PON to DON, and ammonification of DON to ammonia. Both PON and DON have biodegradable and unbiodegradable fractions. The biodegradable (S_{ND}) and unbiodegradable (S_{NI}) fractions of DON in BioWin are assumed to be same as BDON and the difference between DON and BDON (also known as non-biodegradable DON or NBDON). Hydrolysis of biodegradable portion of PON (X_{ND}) and ammonification of DON can be modeled using Monod expressions. The influent NBDON (defined in BioWin nomenclature as soluble unbiodegradable total Kjeldahl nitrogen, F_{nus}) is not removed in any of the treatment processes. It should be noted that the influent NBDON definition is valid because NH_3-N within total TKN is considered biodegradable (nitrifiable). BioWin requires two nitrogen species in the influent from the user: TKN and nitrate. The model then estimates the remaining species shown in the schematic in Figure 4.2 using the influent fractionation information given along with influent data.

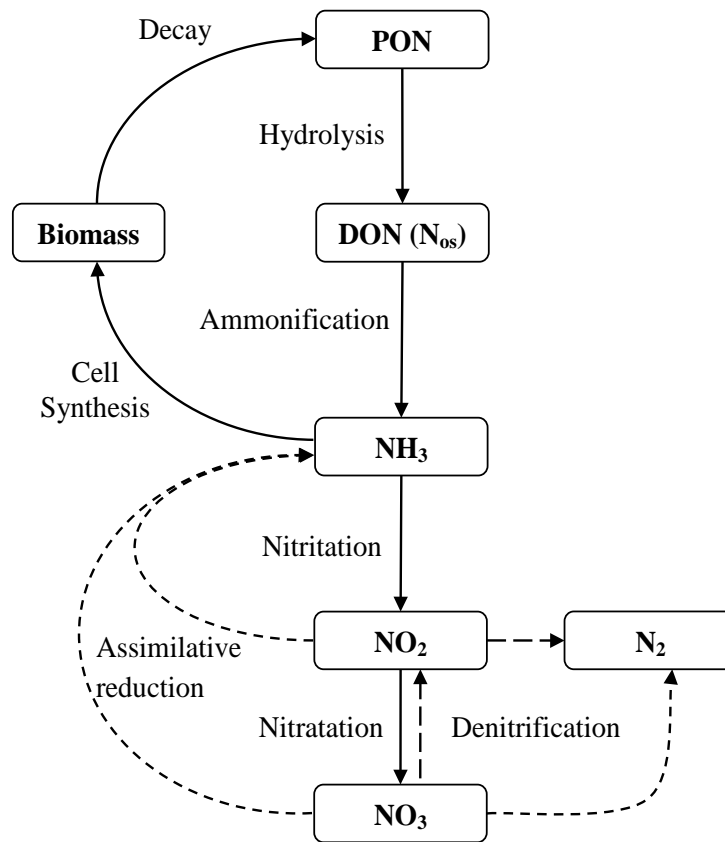

Figure 4.2. Conceptual nitrogen transformations in the BioWin model.

4.2.3.2. Influent fractionation

For accurate process modeling, detailed fractionation data of the influent is required. According to Henze et al. (1987), the influent TKN can be fractionated as shown in Equation 4.1 below, assuming that no biomass is present in the influent wastewater.

$$\text{TKN} = X_{\text{NI}} + X_{\text{ND}} + S_{\text{NI}} + S_{\text{ND}} + S_{\text{NH}} \quad (4.1)$$

where, X_{NI} is particulate biodegradable organic nitrogen. More detailed information on the fractions used in BioWin to represent influent TKN components may be found in the software user manual (EnviroSim Associates, 2007). Historical plant sampling data and a plant audit report by Ulteig Engineers, Inc. (Ulteig Engineers, Inc., 2010) were used for

influent wastewater characterization and fractionation calculations. BioWin allows user to input soluble, particulate, biodegradable, and unbiodegradable fractions of COD and nitrogen species. A selected set of BioWin default fractionation information is summarized in Table 4.1.

4.2.3.3. Model setup, calibration, and validation

Daily average flow rates and annual average concentrations for various model inputs were used during the steady state model setup. The constant influent inputs used in the model are summarized in Table 4.1. The steady state model configuration is presented in Figure 4.3. Clarifiers were modeled using the modified Vesilind secondary settler model, which simulates a settling tank as a one dimensional settling with multiple layers (minimum of 5). The height of the trickling filters was discretized into four layers in the BioWin model, with each layer representing one quarter of the trickling filter height. This approach has been used successfully elsewhere (Bilyk et al., 2008). Each layer in BOD trickling filter was configured with media having a specific area of $30 \text{ ft}^2/\text{ft}^3$ and specific volume of $0.75 \text{ f}^3/\text{m}^3$. The model was configured using physical characteristics of treatment units obtained from an audit report conducted in 2010 (Ulteig Engineers, Inc., 2010), influent fractionation information (Table 4.1), and influent characteristics (Table 4.1).

The default BioWin kinetic and stoichiometric parameters were utilized during the initial calibration steps. The calibration was based on a trial and error method. Initially, the model was calibrated for BOD and COD by adjusting the influent fractions of carbonaceous substrate expressed as COD (the first five parameters under fractionation data listed in Table 4.1), and kinetic and stoichiometric parameters of ordinary

heterotrophic organisms. Once model simulated BOD and COD were matched with the measured data, DO, influent fractions relevant to nitrogen, and kinetic and stoichiometric parameters relevant to ammonia oxidizing bacteria and nitrite oxidizing bacteria were adjusted to match the model simulated NH_3 , NO_2^- , NO_3^- , TKN, TDN, DON and BDON with the measured data. The measured data were used as references while adjusting the DO values during the calibration.

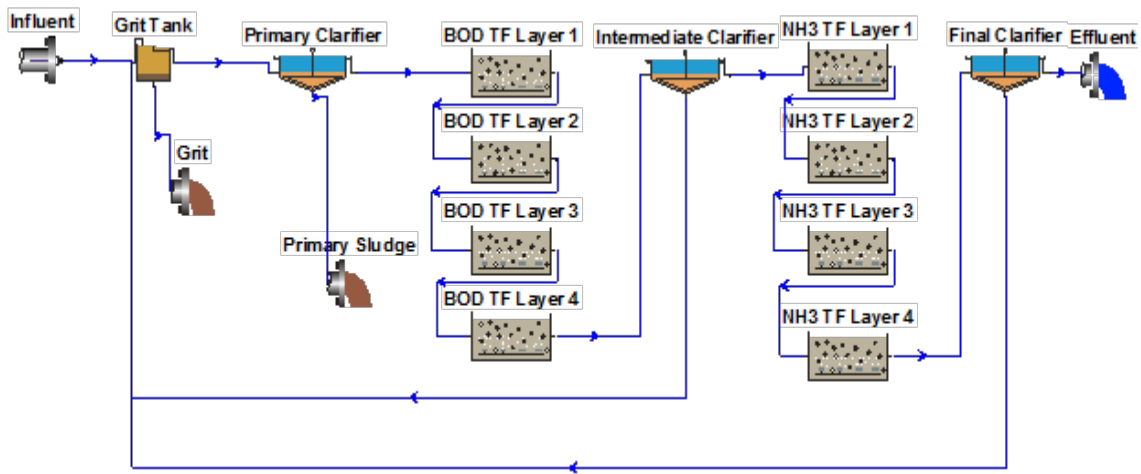

Figure 4.3. The BioWin steady state model for the City of Fargo WWTP. BOD TF – BOD trickling filters; NH3 TF – nitrification trickling filters.

4.2.3.4. Sensitivity analysis

A sensitivity analysis was performed to evaluate the extent to which the parameters used in the model calibration can influence various model outputs. In a linear sensitivity analysis, a relative change in the model output parameter (y_j) in response to a change in the model input variable (θ_i) can be expressed as:

$$\delta_{i,j} = \left| \frac{\Delta y_j / y_j}{\Delta \theta_i / \theta_i} \right| \quad (4.2.)$$

The influence of a calibration parameter on a model output parameter was interpreted using the following categories: if $\delta_{i,j} < 0.25$, the model is insensitive to the calibration

parameter; if $0.25 < \delta_{i,j} < 1$, the calibration parameter is influential; if $1 < \delta_{i,j} < 2$, the calibration parameter is very influential; if $\delta_{i,j} > 2$, the calibration parameter is extremely influential (Peterson et al., 2003).

Table 4.1. Steady state model influent data.

Element name	Value
1. Fractionation Data	
F_{bs} - Readily biodegradable (including Acetate) [g COD/g of total COD]	0.16
F_{ac} - Acetate [g COD/g of readily biodegradable COD]	0.15
F_{xsp} - Non-colloidal biodegradable [g COD/g of slowly degradable COD]	0.75
F_{us} - Unbiodegradable soluble [g COD/g of total COD]	0.05
F_{up} - Unbiodegradable particulate [gCOD/g of total COD]	0.13
F_{na} - Ammonia [g NH ₃ -N/g TKN]	0.66
F_{nox} - Particulate organic nitrogen [g N/g Organic N]	0.5
F_{nus} - Soluble unbiodegradable TKN [g N/g TKN]	0.02
F_{upN} - N:COD ratio for unbiodegradable part. COD [g N/g COD]	0.035
2. Annual Average Flow Characteristics	
Flow (MGD)	13
Total COD (mg/L)	721
Total Kjeldahl Nitrogen (mg/L)	33.1
Nitrate-N (mg/L)	0.2
Total P (mg/L)	10
Alkalinity (mmol/L)	2.2
Inorganic suspended solids (mg/L)	120
pH	7.35

In the present study, a sensitivity analysis was performed on steady state simulations around BioWin's default parameters. The following parameter categories were considered as input variables (θ_i) in the sensitivity analyses: influent fractionation (*e.g.* biodegradable and soluble fractions), operating variables (*e.g.* recycle and wastage flows), stoichiometric (*e.g.* N and P contents) and kinetic parameters (*e.g.* maximum specific growth rates and half saturation constants), biofilm characteristics (*e.g.* thickness and

layers). Additionally, the effect of BioWin switching functions was also included as one of the input variables. Ammonia, nitrite, nitrate, DON (calculated from BioWin outputs: filtered TKN and ammonia), and soluble biodegradable organic nitrogen (or BDON) were chosen as the model output variables (y_j). The analysis was performed by providing a 10% perturbation to the parameters summarized in Table 4.2.

Table 4.2. Model input parameters used in sensitivity analysis.

Parameter	Default value	Units
1. Kinetic and stoichiometric parameters		
Kinetic		
Ammonia oxidizing bacteria (AOB)		
Maximum specific growth rate	0.9	day ⁻¹
Substrate half saturation	0.7	mg N/L
Nitrite oxidizing bacteria (NOB)		
Maximum specific growth rate	0.7	day ⁻¹
Substrate half saturation	0.1	mg N/L
Heterotrophs		
Hydrolysis rate (AS)	2.1	day ⁻¹
Hydrolysis half saturation	0.06	
Ammonification rate	0.04	L/(mg N d)
Nitrite oxidizer dissolved oxygen half saturation	0.5	mgO ₂ /L
Stoichiometric		
N in endogenous residue	0.07	mg N/mg COD
N in biomass (for AOB, NOB, and heterotrophs)	0.07	mg N/mg COD
2. Influent characterization		
Soluble unbiodegradable TKN (F_{nus})	0.02	g N/g TKN
N:COD ratio for unbiodegradable particulate COD (F_{upN})	0.035	g N/g COD
Unbiodegradable soluble (F_{us})	0.05	g COD/g of total COD
Unbiodegradable particulate (F_{up})	0.16	g COD/g of total COD
3. Operating variables		
Dissolved oxygen for the trickling filters	3 [£]	mg/L
Combined recycle of settled solids from intermediate and final clarifiers	0.35 [£]	MGD
4. Biofilm characteristics		
Thickness	100	µm
Layers	2	

[£]Based on personal communication with plant operators.

4.2.4. Analytical methods

All samples were analyzed in triplicates. The glassware were washed with soap, rinsed with tap water, kept in a 5% v/v hydrochloric acid bath overnight and rinsed with DDW before use. BOD was measured according to Standard Methods (APHA et al., 1998) and raw wastewater from the plant was used as a seed. For COD measurement, either a high range (0-1500 mg/L) or low range (0-150 mg/L) COD kit from Hach Company (Loveland, CO, USA) was used (Hach method # 8000 for both high and low range values). TKN was measured using semi-automated colorimetry according to EPA Method 351.2 (US EPA, 1993). DO concentration was analyzed immediately after samples were collected using a DO meter (Model # 5910, YSI Incorporated, Yellow Springs, OH, USA). The procedures for measuring ammonium, nitrite, nitrate, and TDN were presented in Section 3.2.5. After determining DIN and TDN, DON was calculated using Equation 2.1.

4.2.5. Statistical analysis

Two-way ANOVA using a GLM procedure of SAS (version 9.2; SAS Institute, Cary, NC) was conducted to determine the statistical differences in DON and BDON concentrations and BDON degradability (BDON to DON ratio) between summer and winter data. In ANOVA, seasons were treated as main plots and treatment processes were treated as subplots, considering sampling dates as replications within each season.

4.3. Results and Discussion

The profiles of different dissolved nitrogen species (ammonia, nitrite, nitrate, and total nitrogen) along the treatment train of the Fargo WWTP are presented in Figure 4.4., and DON and BDON profiles are shown in Figure 4.5. Model calibration results for BOD, COD, ammonia, nitrite, nitrate, TDN, DON and BDON are presented in Figure 4.6. The

data and error bars are based on averages and standard deviations of 18 different samples (from 18 different weeks). Due to weather conditions such as rain and snow, influent nitrogen concentrations fluctuated. In summer, nitrogen concentrations were high since there was minimal dilution involved.

4.3.1. Inorganic nitrogen species and TDN

Ammonia in the influent of the Fargo WWTP averaged 23.83 mg N/L. The plant achieved almost complete ammonia removal through nitrification which occurred in both BOD and nitrification trickling filters (Figure 4.4a). About 50% of ammonia was removed in the BOD trickling filters, while about 90% of the remaining ammonia was removed in the nitrification trickling filters. All of the ammonia in the samples was nitrified during the BDON incubation except for raw and primary wastewater sample in which there were low amounts of ammonia left (< 1.0 mg/L).

Average nitrite concentration in all the samples was consistently very low (< 0.1 mg N/L, Figure 4.4b). After the incubation, nitrite in the samples before and after primary clarification was 25.21 and 22.93 mg N/L, while nitrate at these locations was 3.03 and 4.61 mg N/L respectively. This was likely due to inadequate DO for nitrification (nitrite conversion to nitrate) during the incubation. However, the last several sets of samples, more frequent manual DO recharging was experimented and almost full nitrification (nitrite < 0.01 mg N/L) was achieved in these samples after the incubation. Nitrate was usually present in very low concentrations (at an average of 0.20 mg N/L) in the raw wastewater samples (Figure 4.4c). However, it was the major portion of DIN after the nitrification filters (93%).

Nitrate nitrogen in almost all of the nitrification trickling filter effluent samples was substantially less than the ammonia nitrogen in the plant influent. An average of 4.50 mg N/L difference was observed between influent ammonia-N and effluent nitrate-N. Previous studies indicated two possible reasons for this nitrogen loss: assimilation of ammonia by biomass in the trickling filters and/or possible denitrification in the deeper portions of biofilm (Hanaki et al., 1990; Eiroa et al., 2005). Additionally, nitrate may also be used for biomass synthesis in the event of insufficient ammonia (Grady et al., 1999). The third scenario needs not be considered here as there was always sufficient amount of ammonia present in the nitrification trickling filters (> 12.0 mg N/L).

Average nitrate values after the incubation in the samples from the remaining locations followed a similar trend as that of before the incubation. The nitrate nitrogen concentrations in the samples after the incubation were however slightly higher than before the incubation. A possible reason for this increase in nitrate concentration could be nitrification of ammonia from two different sources, the residual (untreated) ammonia in the samples and/or the ammonia generated due to ammonification of organic nitrogen during the incubation. Increases of nitrate nitrogen during the incubation ranged from 1.88 to 3.41 mg N/L, which were higher than ammonia nitrogen in the samples (before incubation). Thus, both ammonia sources discussed should have contributed to the nitrate increases after the incubation

The average TDN in the plant influent was 33.15 mg N/L while in the effluent was 25.22 mg N/L. Although the treatment plant was not equipped with nutrient removal processes, it achieved 24% removal of the influent TDN. The removal was observed mainly through the two trickling filters (Figure 4.4d). The removal of TDN can be

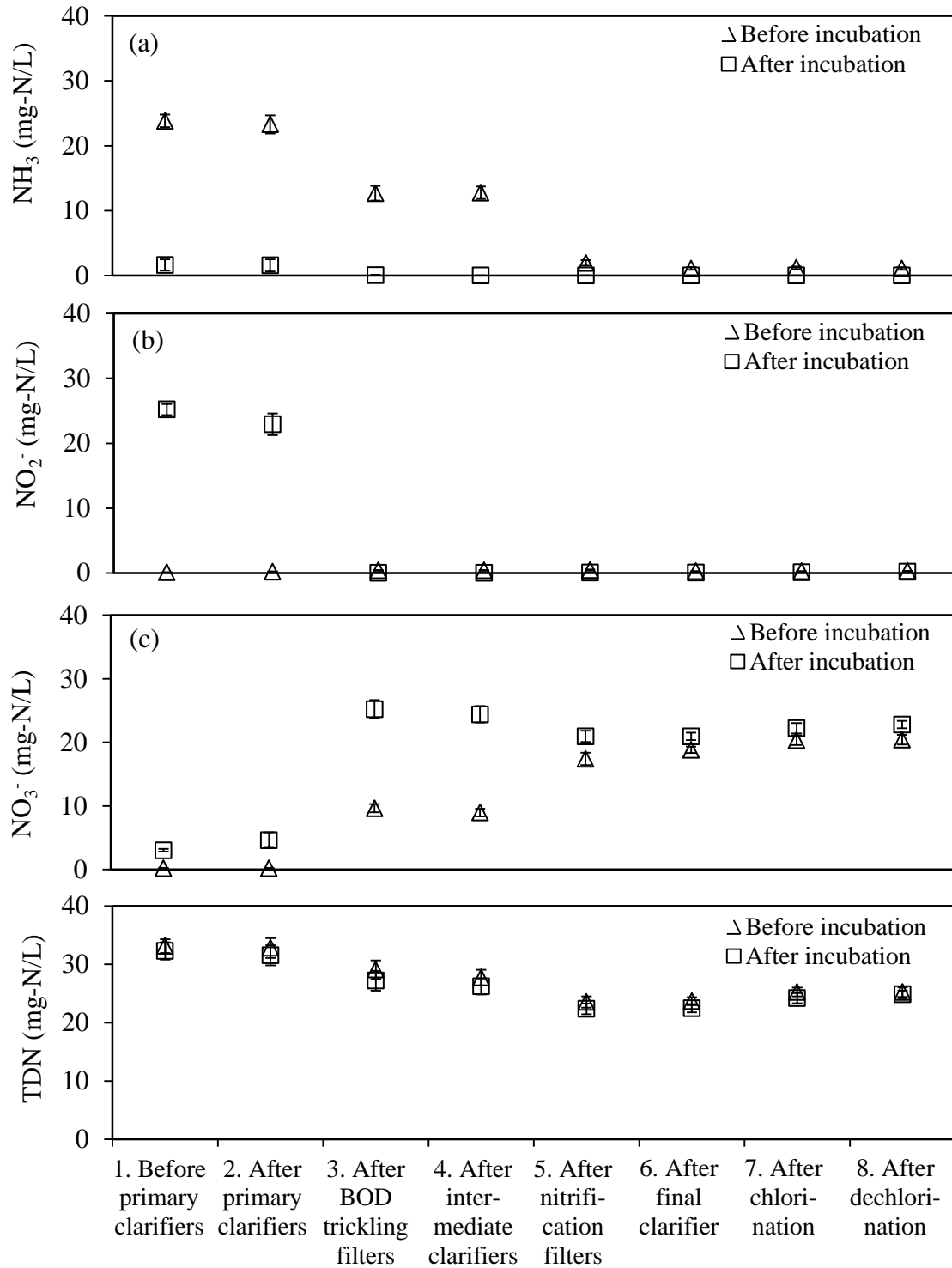

Figure 4.4. (a) Dissolved ammonia (b) nitrite (c) nitrate and (d) total nitrogen in the Fargo wastewater after various treatment units before and after incubation.

explained using the same reasons that were discussed earlier for nitrogen loss in the nitrification trickling filters (assimilation of ammonia by biomass and/or denitrification). The TDN values after the incubation were almost the same and followed the same trend as before the incubation.

4.3.2. Dissolved organic nitrogen

Average DON in the plant influent and effluent were 9.02 and 3.44 mg N/L, respectively (Figure 4.5a). The final effluent DON was substantially higher than a typical range of 1.0 mg/L to 2.5 mg/L reported for a two-stage trickling filter plant and activated sludge plants with and without nutrient removal processes (Evans et al., 2004; Murthy et al., 2006; Pagilla et al., 2006). The treatment plant removed 62% of the influent DON. Similar to inorganic nitrogen removal, major removal of DON was observed in the biological processes of the plant. The BOD trickling filters removed 37% of the influent DON while the nitrification trickling filters removed the same percent from the remaining DON. DON fractions of TDN were 27% and 14% in the raw wastewater and in the plant effluent, respectively (Figure 4.5b).

After the incubation, at least 50% of the DON decreased through ammonification for all the locations (Figures 4.5a, 4.5b). The final DON values after the incubation for all the samples from the WWTP were between 1.61 and 2.60 mg N/L, and their fractions of TDN were between 6.5% and 8% (Figure 4.5a). This indicates that there was about the same fraction of inert DON (not biodegradable) from each treatment process. Statistical analyses showed that there is no significant difference ($p > 0.05$) on DON concentrations in all the locations of the treatment train between the summer and winter months (data not shown). For the summer months, statistically DON concentrations can be categorized into

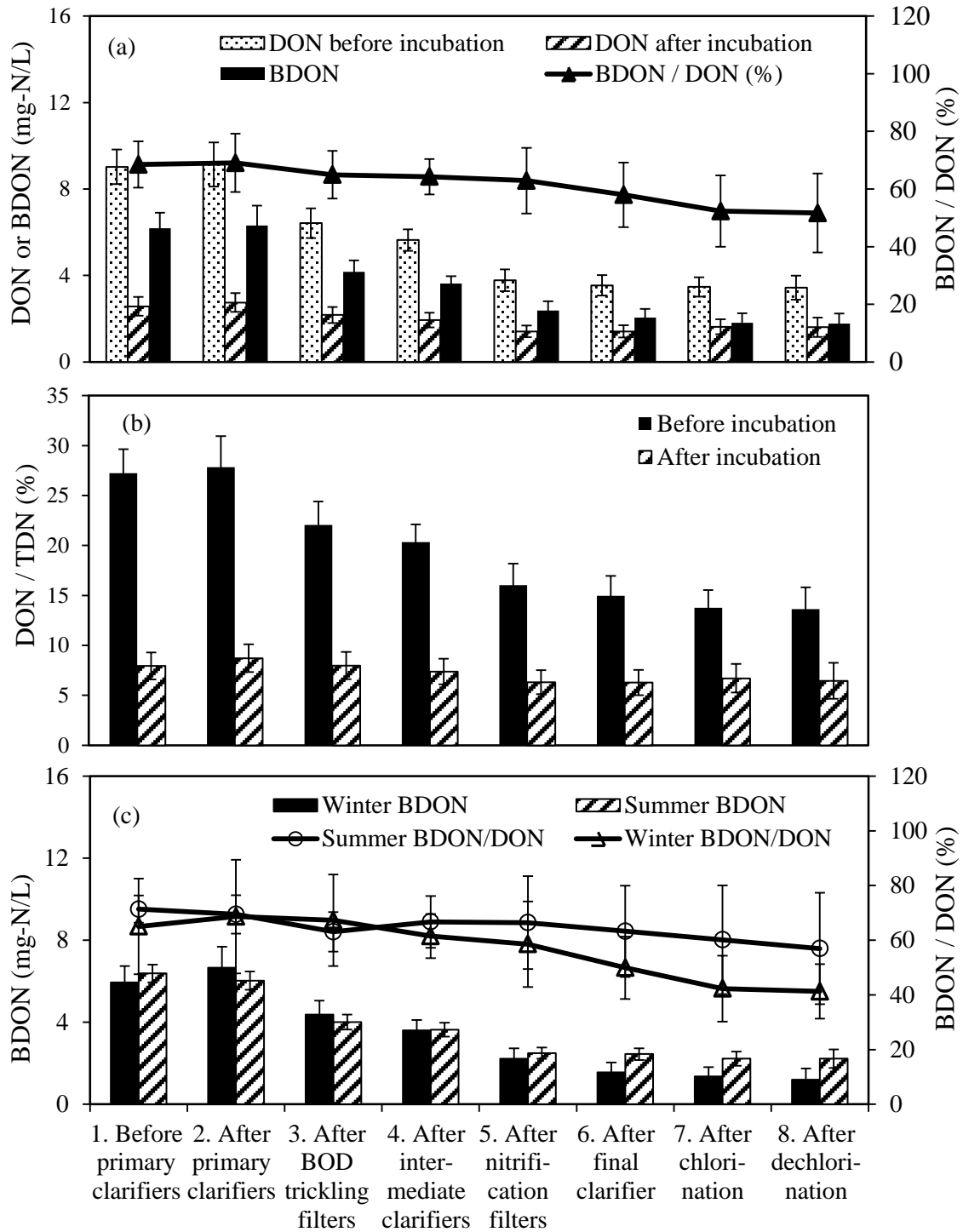

Figure 4.5. (a) DON and BDON (b) dissolved organic nitrogen as a percentage of total dissolved nitrogen (c) BDON as a percentage of DON during summer and winter months in the Fargo wastewater after various treatment units.

three groups and within each group there is no significant difference ($p > 0.05$). These three groups are before and after primary clarifiers, after BOD trickling filters and after intermediate clarifiers, and the rest of the sampling locations. The statistical grouping for the winter months is exactly the same as that for the summer months.

4.3.3. Biodegradable dissolved organic nitrogen

The BDON profile had a similar trend as that of the DON profile along the treatment trains (Figure 4.5a). BDON removal occurred mainly in the trickling filters. BDON in the raw wastewater and plant effluent was 6.18 and 1.78 mg/L respectively corresponding to 72% removal. The BOD trickling filters removed 43% of BDON and the nitrification trickling filters removed 43% of BDON. About 12% removal of BDON was also observed in the chlorination basins. However, the DON concentration did not change after chlorination. Chlorinating DON can form disinfection by-products (DBPs) that contain a nitrogen functional group (Mitch and Sedlak, 2002; Pehlivanoglu-Mantas and Sedlak, 2006). In summer (chlorine disinfection was performed), a portion of BDON could have changed into a form of DON (DBP) that was recalcitrant to biodegradation in the incubation process. The BDON was found to be between 51% and 69% of DON after various treatment units in the plant (Figure 4.5a). In other words, there was 31% or more of biodegradable DON that was not treated by each of the treatment processes.

The BDON plots for the summer and winter months are presented in Figure 4.5c. Statistically, BDON concentrations were not different ($p > 0.05$) between the summer and winter months for all locations. During the summer months, the statistical grouping of BDON concentrations from different treatment units is identical to those of DON concentrations as discussed above. For the winter months, the statistical grouping of

BDON concentrations (for no significant difference) is as follows: 1) Before primary clarifier to after BOD trickling filters; 2) After BOD trickling filters to after nitrification filters; and 3) After nitrification filters to after dechlorination.

Figure 4.5a presents DON biodegradability of DON (BDON/DON) for the entire year sampling (18 weeks). The biodegradability varied between 52% and 68% for all 8 locations in the treatment train. The final effluent DON was 52% biodegradable which is within a range of previously reported values (Pehlivanoglu-Mantas and Sedlak, 2006; Sattayatewa et al., 2009). The DON biodegradability gradually decreased along the treatment train which is logical. The ranges of DON biodegradability in the summer and winter months were 57% to 71% and 41% to 65%, respectively. The differences in BDON concentrations between the summer and winter months, although not statistically different ($p > 0.05$), occurred mainly in the last two units of the treatment train. In the summer months, the decrease in BDON/DON was due to a slight decrease in BDON after chlorination (0.23 mg N/L), while no change occurred in DON. BDON reduction was higher during the winter months since the plant did not employ disinfection in winter. The chlorination and dechlorination basins were simply used as storage tanks, thus providing longer residence time for nitrifiers that did not settle in the secondary clarifiers to continue to remove BDON and eventually DON. This analogy is supported by almost the same magnitude of removal observed for BDON and DON in the final two locations of the plant.

4.3.4. BioWin modeling

4.3.4.1. Model calibration

During the calibration of the model, unbiodegradable soluble (F_{us}) and unbiodegradable particulate (F_{up}) CODs were adjusted to 0.067 and 0.16 g COD/g of total

COD. With the remaining BioWin default influent fractionation (Table 4.1), kinetic (except the hydrolysis rate) and stoichiometric parameters, model simulated BOD and COD profiles fairly matched with the measured values (Figure 4.6a). Hydrolysis rate was changed from a default of 2.1 to 0.5 day⁻¹ for the BOD trickling filters and 1.2 day⁻¹ for the nitrification trickling filters.

The simulation results for ammonia, nitrite, nitrate, TKN and TDN results are presented in Figure 4.6b. While the model simulated nitrite and nitrate matched well with the measured values, ammonia values after the BOD trickling filters and intermediate clarifiers were under-predicted by the model. The parameters that were adjusted from their default values in matching ammonia, nitrite, and nitrate were influent fractionation, AOB and NOB kinetic parameters, DO, and boundary layer thickness. Based on the sampling data, ammonia (F_{na}) in the influent fractionation was adjusted to 0.72 g NH₃-N/g TKN. Kinetic parameters for AOB and NOB are summarized in Table 4.3. DO values between 3.0 and 5.0 mg/L were used to match the predicted NH₃, NO₂, and NO₃ with the measured values (Table 4.3). Higher DO values were provided to the lower layers of the trickling filters (BOD TF Layer 4 and NH₃ TF Layer 4 in Figure 4.3). This type of DO provision in the model was adjusted based on the configuration of the trickling filters. The Fargo WWTP has a natural ventilation system for air flow from the bottom of the filters. Moreover, grab sample measurements of DO during the winter showed a similar trend as the calibrated values for the BOD trickling filters (Table 4.3).

The boundary layer thickness was also used as a calibration parameter which controls the mass transfer rates of various constituents (such as DO, BOD, and ammonia) into the biofilm. This parameter was mainly used to adjust the nitrification by controlling

the amount of DO available to the bacteria within the biofilm. The calibrated boundary layer thickness was 80 μm for the BOD trickling filters and 150 μm for the nitrification trickling filters, while the default value in BioWin is 100 μm . Most of the DO was consumed for BOD removal in the BOD trickling filters. The model simulated DO in the lower layers of the biofilm in the BOD trickling filters was less than 0.1 mg/L. The thickness of boundary layer in these trickling filters was kept at 80 μm in order to allow sufficient DO diffusion into the biofilm and to maintain aerobic conditions required for nitrification. On the contrary, a higher thickness (150 μm) of the boundary layer was needed in the nitrification trickling filters in order to optimize the rates of nitrification and nitrification.

Table 4.3. Calibrated kinetic, stoichiometric and operational parameters.

Parameter	Default	Calibrated	Measured
1. Kinetic			
AOB Max. spec. growth rate [1/d]	0.9	1.2	
Substrate (NH_4) half sat. [mg N/L]	0.7	0.7	
NOB Max. spec. growth rate [1/d]	0.7	1	
Substrate (NO_2) half sat. [mg N/L]	0.1	0.1	
2. Stoichiometric			
AOB Yield [mg COD/mg N]	0.15	0.15	
AOB Yield [mg COD/mg N]	0.09	0.09	
N in biomass [mg N/mg COD]	0.07	0.07	
3. Dissolved oxygen set points (mg/L)			
BOD TF Layer 1		4.0	5.2
BOD TF Layer 2		4.0	
BOD TF Layer 3		5.0	
BOD TF Layer 4		5.0	6.3
NH ₃ TF Layer 1		3.0	
NH ₃ TF Layer 2		3.0	
NH ₃ TF Layer 3		4.0	
NH ₃ TF Layer 4		4.0	

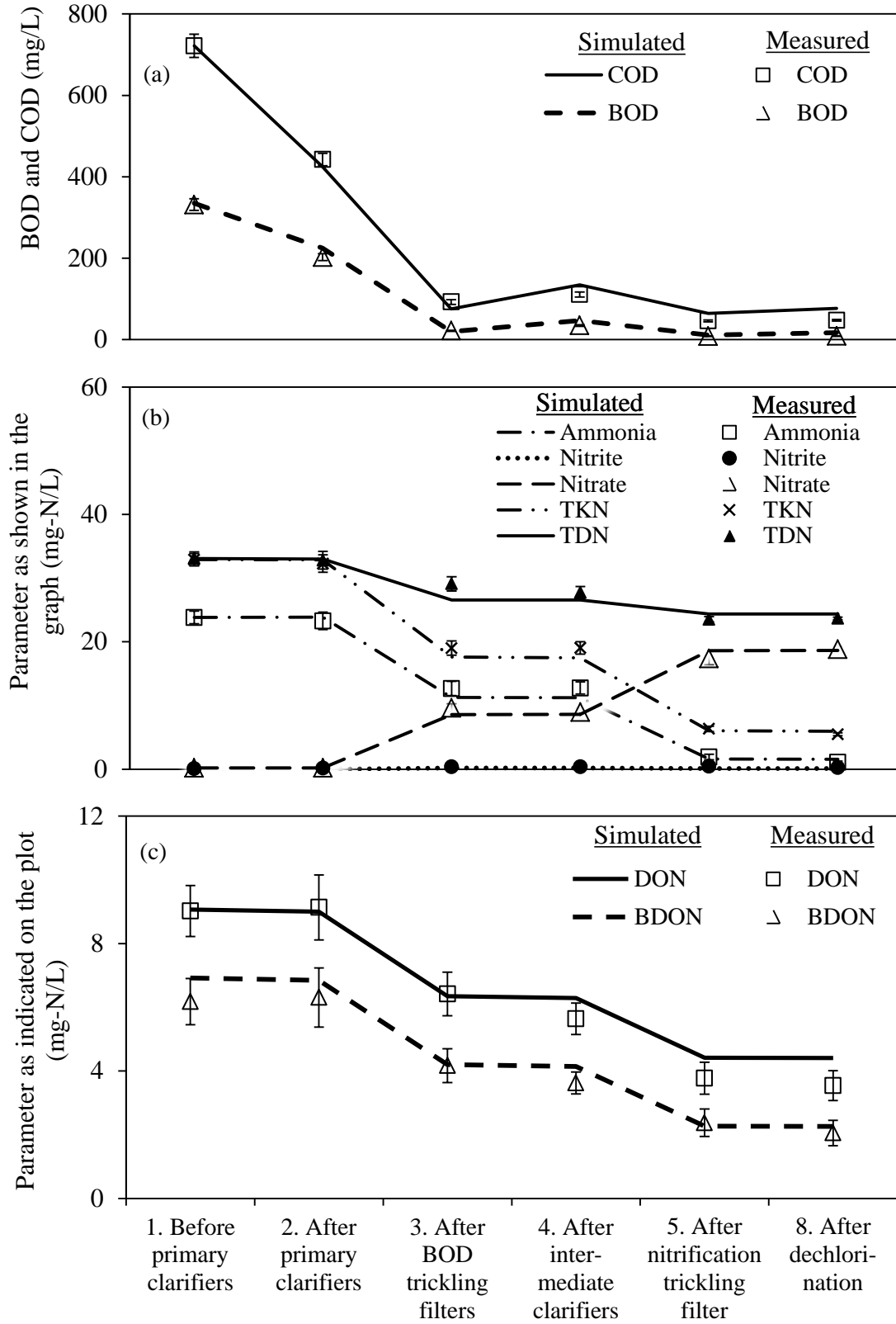

Figure 4.6. BioWin model simulated versus measured profiles of (a) BOD and COD (b) ammonia, nitrite and nitrate, TDN and (c) DON and BDON data along the treatment plant.

Simulation results showed that partial nitrification (accumulation of nitrite) did not occur in any of the BOD or nitrification trickling filter layers. Moreover, the growth of anaerobic ammonia oxidizers was not observed in the simulations. However, the model was able to simulate the loss of dissolved nitrogen, which was observed as the difference between ammonia nitrogen removed and nitrate nitrogen produced after the BOD and nitrification trickling filters in the measured data (Figure 4.6b). The model simulations predicted this loss of dissolved nitrogen as the production of particulate organic nitrogen.

TDN was calculated from the BioWin simulated TKN, nitrite and nitrate values. Overall, the profiles of TDN and TKN simulated by the model fairly matched with the measured data (Figure 4.6b). DON and BDON profiles are presented in Figure 4.6c. The simulation results were quite agreeable with the measured data. The calibration parameters used in matching the simulated values for DON and BDON with measured data were influent fractionation parameters and kinetic parameters.

The adjusted influent fractionation parameters were particulate organic nitrogen (F_{nox}) to 0.005 g N/g organic N, soluble unbiodegradable TKN (F_{nus}) to 0.065, and N:COD ratio for unbiodegradable particulate COD (F_{upN}) to 0.001. The majority of the measured influent TDN was ammonia and organic nitrogen (> 99%). Hence, the measured TDN value was used as the influent TKN for model simulations. Since the influent TKN was dissolved, F_{nox} and F_{upN} were assumed to be negligible. Measured DON and BDON results showed that an average NBDON (DON - BDON) was 2.15 mg/L, which was about 6.5% of the TDN (or $F_{\text{nus}} = 0.065$).

Hydrolysis rate and ammonification rate for heterotrophs were adjusted to match the simulation results with the measured data; however, the values were different for the

BOD and nitrification filters. A default value of 2.1 day^{-1} for hydrolysis rate is recommended for activated sludge systems by EnviroSim Associates Ltd. (2007). The calibrated hydrolysis rates were less than the default values, which were 0.5 day^{-1} for the BOD trickling filters and 1.2 day^{-1} for the nitrification trickling filters. The slower hydrolysis rate in the BOD trickling filters indicates that a slower hydrolysis of complex particulate matter and a higher rate in the nitrification trickling filters could be due to relatively less complex particulate matter. The hydrolysis rates were adjusted mainly to match the measured DON and BDON.

The calibrated ammonification rates were 0.01 L/mg N-day for the BOD trickling filters and 0.04 L/mg N-day for the nitrification trickling filters. The slower ammonification rates indicate that some of the hydrolyzed organic nitrogen could have been directly used for cell synthesis (Warner, 1956). The measured data (from 28-day incubation) showed a variation in the concentration of NBDON along the treatment processes. The NBDON was $2.57 \pm 0.44 \text{ mg N/L}$ in the influent and $1.62 \pm 0.35 \text{ mg N/L}$ in the effluent. However, BioWin simulates NBDON as a constant fraction of the DON, which means that it does not change along the treatment processes.

NBDON in wastewater treatment systems is not a constant fraction as noticed from the measured data (which is the difference between measured DON and BDON values in Figure 4.6c). Adsorption of influent NBDON to the biofilm in trickling filters and release of NBDON from bacterial growth and decay influence the amount of NBDON in the effluent (Parkin and McCarty, 1981a). Further improvements to the BioWin software are necessary to incorporate these processes. The existing software accounts for release of

unbiodegradable soluble COD from the decay of polyphosphate organisms. However, this release is not currently considered by BioWin for the estimation of NBDON.

4.3.4.2. Sensitivity analysis

Results from the sensitivity analyses on calibrated BioWin model are summarized in Table 4.4. The values for $\delta_{i,j}$ for model output parameter nitrite and calibration parameter K_{S,NO_2} were less than 0.2. Hence, they were not included in Table 4.4. A large number of calibrating parameters influenced the model output for ammonia, nitrate and DON, while COD, BOD, NBDON, X_{ND} and TDN were influenced by two parameters each.

Although the switching parameters were found to be less influential, they were necessary to match the simulated values of nitrate with those of the measured. The influence category for each calibrating parameter varied depending on the output variable. Among the kinetic parameters, the maximum specific growth rate for AOB was found to be extremely influential for ammonia, while it was very influential for nitrate. The AOB half saturation constant was found to be very influential for ammonia, but was influential for nitrate. Similarly, hydrolysis rate was extremely influential for BOD, ammonia, nitrate, and particulate biodegradable organic nitrogen, while it was very influential for COD and influential for DON and TDN. Among the influent characterization parameters, F_{upN} was influential for ammonia, DON and soluble inert TKN (or NBDON). The influence of F_{upN} on NBDON was mainly because of hydrolysis of particulate organic nitrogen. Among the operational variables, recycle flow rate had influence on ammonia alone, while DO had varying levels of influence on most of the nitrogen species. It should be noted that the sensitivity of DON and BOD to the parameters identified in this study is more specific to

the treatment systems equipped with trickling filters, and should be verified for their applicability to other treatment systems, such as activated sludge.

Table 4.4. The values for $\delta_{i,j}$ for the most sensitive parameters of the calibrated BioWin model.

Elements	$\delta_{i,j}$								
	COD	BOD	NH ₃	NO ₃	DON	BDON	Sol. inert TKN*	Part. bio. org. N**	TDN
1. Kinetic parameters									
μ_{\max, NH_3}			3.33	1.05					
K_{S, NH_3}			1.58	0.27					
μ_{\max, NO_3}			0.48	3.17					
K_{S, NO_3}				0.16					
Hydrolysis Rate	1.2	4.0	5.77	4.89	0.85	1.46		14.3	0.9
Ammonification Rate			0.48	0.16	0.65	1.10			
Nitrite oxidizer DO half saturation				0.79					
Heterotroph DO half saturation				0.43					
Aerobic denitrifier DO half saturation				0.43					
2. Influent characterization									
F_{nus}					0.56				
F_{upN}			0.64		0.54		0.7		
3. Operating variables									
Recycle flow rate	1.2	1.2	1.61						
DO		0.3	4.74		0.71	0.45	1.1	0.62	

*unbiodegradable DON (NBDON)

**Particulate biodegradable organic nitrogen (X_{ND})

4.4. Summary

The fate of DON and BDON in a two-stage trickling filter wastewater treatment plant was investigated. Comprehensive data were collected from a full-scale treatment

plant for one year and the BioWin model was used to simulate nitrogen species concentrations including DON and BDON along the treatment train. Understanding the removal of DON in wastewater treatment plants has become more and more critical due to stringent limits on effluent nitrogen. The study showed that the trickling filters removed substantial amounts of DON and BDON; however, the discharged concentrations in the effluent were still high enough to be critical if a total nitrogen limit in the effluent is below 5 mg N/L. The trickling filter process by itself may not be able to meet the low TN standard but can be combined with nutrient removal (denitrification) processes to achieve that. The successful application of the modeling identified the important processes and influential parameters in simulating the fate of DON and BDON through the trickling filter process. The modeling results are useful for future upgrading of the plant to meet more demanding effluent nitrogen limits.

**CHAPTER 5. BIOAVAILABLE AND BIODEGRADABLE DISSOLVED
ORGANIC NITROGEN IN ACTIVATED SLUDGE AND TRICKLING FILTER
WASTEWATER TREATMENT PLANTS**

5.1. Introduction

Current regulations for TN in WWTP effluents in many parts of the United States are approaching 5 mg N/L or less to control eutrophication and hypoxia conditions in estuaries and bays. With recent advances in nutrient removal technologies, WWTPs are able to achieve high inorganic nitrogen removal, leading to DON being a major nitrogen form (> 50%) of the effluent TDN. Parkin and McCarty (1981) reported that about 70% of the total influent DON can be removed by suspended growth systems of WWTPs. Simsek et al. (2012) reported that 62% of the influent DON was removed by a TF treatment process. The effluent DON was still about 50% and up to 70% biodegradable (ammonifiable) for AS and TF WWTPs, respectively (Murthy et al., 2006; Simsek et al., 2012).

Traditionally effluent DON was believed to be fully non-biodegradable and hence would not be available as a nutrient source in receiving waters. However, recent studies have shown that effluent DON comprises of various forms of organic nitrogen that can be available to natural algae and plankton (Pehlivanoglu and Sedlak, 2004, Sattayatewa et al., 2009, Filippino et al., 2011). DON in treated effluent plays an important role in nitrogen cycling. Some forms of DON such as free amino acids can be readily bioavailable for a direct algal uptake while some forms are bioavailable after bacterial degradation (Pehlivanoglu and Sedlak 2004; Bronk et al., 2007). DON can become more bioavailable to algae through hydrolysis and/or mineralization (to NH_4^+ or NO_3^-) by bacteria. BDON is

a portion of DON that can be mineralized by an acclaimed mixed bacterial culture (Khan et al., 2009) while ABDON is a fraction of DON that is directly or indirectly available as a nitrogen source for aquatic plant species (Pehlivanoglu and Sedlak 2004; Pehlivanoglu-Mantas and Sedlak, 2006; Sattayatewa et al., 2009).

Studies on BDON and ABDON in wastewater effluent and aquatic environment have been conducted (Pehlivanoglu and Sedlak 2004; Murthy et al., 2006; Khan et al., 2009; Sattayatewa et al., 2009; Bronk et al., 2010; Filippino et al., 2011; Simsek et al., 2012). Sattayatewa et al. (2009) determined BDON and ABDON in the effluent from a 4-stage Bardenpho process. They used MLSS and a pure culture alga *S. capricornutum* as inocula for BDON and ABDON measurements, respectively. Also, a combined bacterial and algal inoculum was used for ABDON determination. They reported that about 28-57% of the effluent DON was bioavailable or biodegradable regardless of the type of the test species used. DON reduction rate during the ABDON incubation with the combined inoculum was 0.13 day^{-1} compared to 0.04 day^{-1} during the BDON incubation. Sattayatewa et al. (2009) further reported that there was a symbiotic relationship between algae and bacteria and this could shorten the incubation time for the ABDON procedure. Other studies also obtained the same result on the relationship between algae and bacteria in ABDON procedures (Pehlivanoglu and Sedlak, 2004; Urgan-Demirtas et al., 2008).

Bioavailability of DON (ABDON/DON) of the effluents from AS WWTPs to algae can be as high as 40% while that to algae and bacteria together is up to 60% (Urgan-Demirtas et al., 2008). Previous studies on effluent DON bioavailability, however, used the samples from WWTPs that are equipped with TDN removal technologies (Pehlivanoglu and Sedlak, 2004; Bronk et al., 2010; Filippino et al., 2011). The ABDON in the effluents

from TF WWTPs has not been studied. In addition, previous studies on ABDON (Pehlivanoglu and Sedlak, 2004; Bronk et al., 2010; Filippino et al., 2011) did not focus on its fate through various stages of WWTPs.

Simsek et al. (2012) examined the fate of BDON through a full-scale two-stage trickling filter WWTP. BDON was removed mainly by the trickling filters (both stages). Average BDON removal efficiency by the entire treatment plant and final effluent BDON concentration were 72% and 1.80 mg N/L. DON biodegradability (BDON/DON) for raw wastewater samples and samples from all treatment units varied from 51% to 69%. Other than the work by Simsek et al. (2012), there has been no study available on a BDON profile along a WWTP particularly one with activated sludge process. The fate of ABDON through a WWTP has never been investigated. Knowledge on the fate of BDON and ABDON along treatment train helps to understand the roles of WWTP treatment units in the removal of these different types of nitrogen. The objective of this study was to determine the fate of BDON and ABDON along the treatment trains of a WWTP equipped with an AS system and a WWTP equipped with a TF system. It should be noted that the fate of BDON through a TF WWTP was investigated again to compare the results with ABDON values based on the same samples.

5.2. Materials and Methods

5.2.1. Sample sources and plant description

Samples were obtained from two different wastewater treatment plants, which are the City of Fargo WWTP (Fargo, ND, USA), and the City of Moorhead WWTP (Moorhead, MN, USA). The description of the Fargo WWTP is given in Section 4.2.1. The Moorhead WWTP has a peak pumping capacity of 10 MGD and an average flow of 4

MGD. The plant has to comply with the discharge limits for BOD and ammonia (based on the receiving river flow rate) but is not subject to any TN or total phosphorus limits. The Moorhead WWTP is not regulated for fecal coliform in the winter months (November to March) and therefore do not chlorinate and dechlorinate during that period.

The City of Moorhead WWTP treats the wastewater for BOD and ammonia through HPO-AS and MBBR (Figure 5.1). The SRT of the HPO-AS process is 3 days. The WWTP discharges its treated effluent to the Red River. Settled solids from secondary clarifiers are dewatered through dissolved air flotation thickeners and stabilized using anaerobic digesters. The treated biosolids are stored in a biosolids storage tank and land applied during the summer months. Decanted supernatant from the thickeners is sent back to flow equalization basins at the head of the plant.

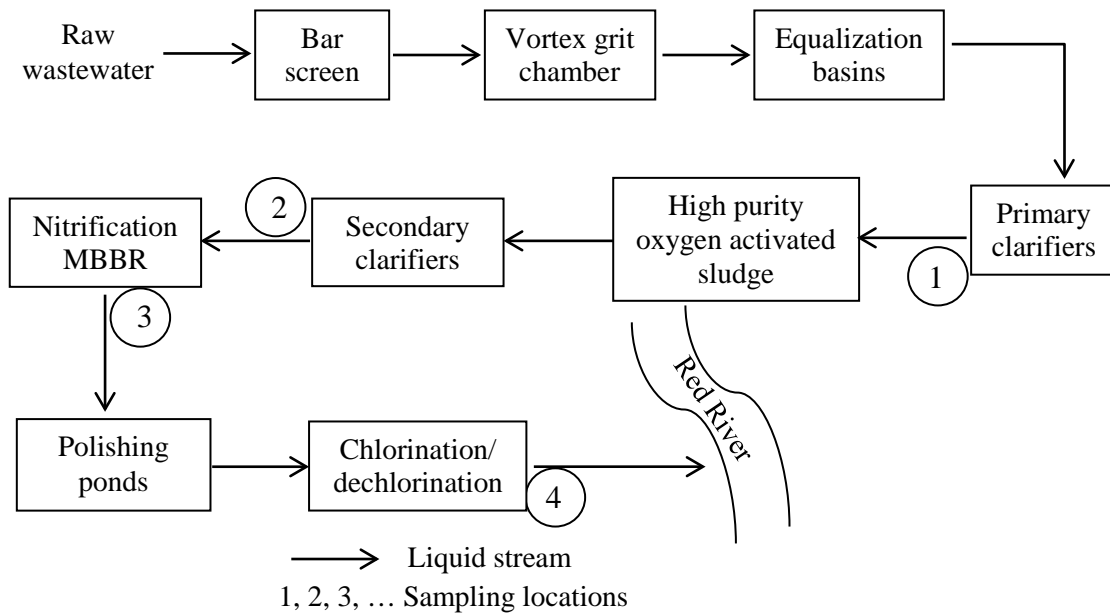

Figure 5.1. A simplified schematic diagram of the City of Moorhead WWTP.

5.2.2. Sample collections, and sources and preparations of inocula

Grab samples were collected from four different locations along the treatment train of the Moorhead WWTP (Figure 5.1) and the Fargo WWTP (Figure 5.2). The samples

were collected on a monthly basis for five months during the winter season from both plants. One liter sample was collected from each sampling location from both WWTPs.

Bacterial inocula for BODN determination were collected from the Fargo and Moorhead WWTPs and used to inoculate in their respective samples. Raw wastewater sample was used as a bacterial inoculum for the Fargo WWTP samples. The Fargo WWTP recycles settled solids from intermediate and final clarifiers and hence, the influent wastewater contains a representation of mixed bacterial culture in the treatment facility. For the samples from the Moorhead WWTP, diluted MLSS (10 fold dilution of approximately 2,500 mg suspended solids/L) were used as a bacterial inoculum. Cultivation and maintenance of *S. capricornutum* (UTEX, University of Texas Culture Collection of Algae, Austin, TX, USA) were performed according to the instruction provided by the culture manufacturer (UTEX, 2011).

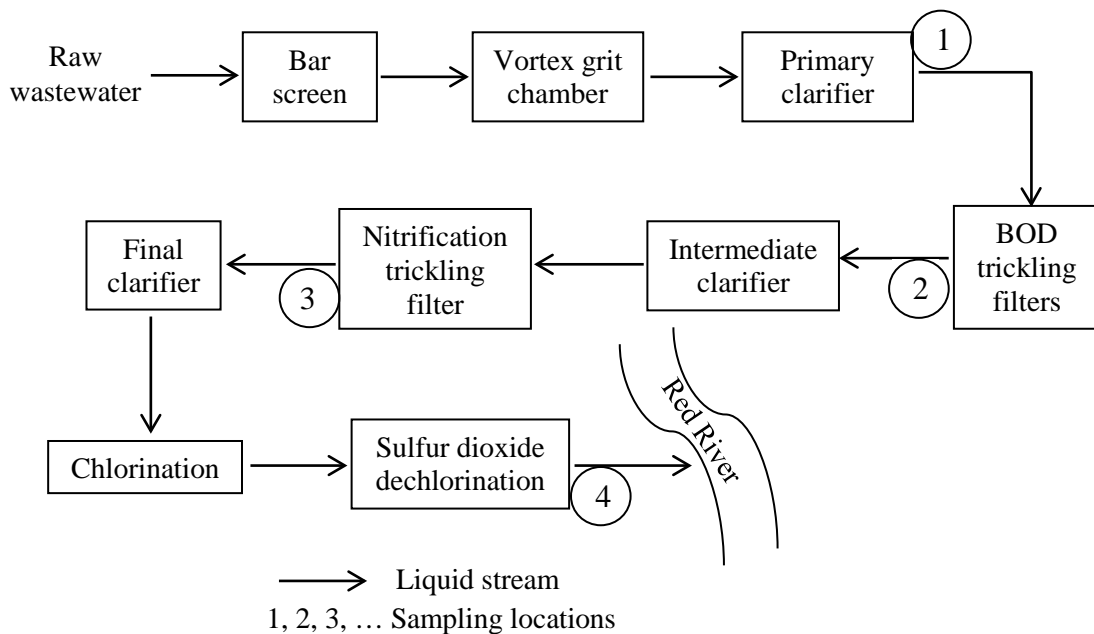

Figure 5.2. A simplified schematic diagram of the City of Fargo WWTP.

5.2.3. DON, BDON and ABDON determination procedures

Samples were analyzed for DON, BDON and ABDON. Each sample was filtered through a 0.2 µm pore-size hydrophilic polyethersulfone membrane filter (Pall Co., Port Washington, NY, USA) immediately after collection. Samples with high concentrations of total solids (mainly primary clarifier effluent) were initially filtered through a 1.2 µm pore-size Whatman glass microfiber filter (Whatman Inc., Kent, UK) before filtering through the 0.2 µm pore-size membrane filter. The filtered samples were autoclaved for 15 minutes to remove any remaining bacteria. DON and BDON were determined as explained in Section 3.2.4.

The ABDON procedure used in this study is very similar to that of BDON with slight differences. In BDON determination, bacteria is used as the seed (Khan et al., 2009), while in ABDON determination, algae or bacteria + algae is used as the seed (Pehlivanoglu and Sedlak, 2004; Urgun-Demirtas et al., 2008; Sattayatewa et al., 2009). The BDON procedure requires incubation in the dark to control algal growth, while ABDON determination requires algal growth and hence, the incubation is conducted under natural or artificial light conditions. A schematic diagram depicting the ABDON procedure is presented in Figure 5.3.

ABDON was performed in 250 mL clear glass bottles and the samples were seeded with 5 mL pure culture algae (*S. capricornutum*) or 2 mL mixed culture bacteria + 5 mL *S. capricornutum* (Pehlivanoglu and Sedlak, 2004; Sattayatewa et al., 2009; Urgun-Demirtas et al., 2008). For all inoculation conditions for ABDON, the sample volume was 200 mL and the incubation period was 28 days. All the experiments were conducted at 20°C. All the ABDON samples were agitated using an orbital shaker at 80 rpm during the incubation.

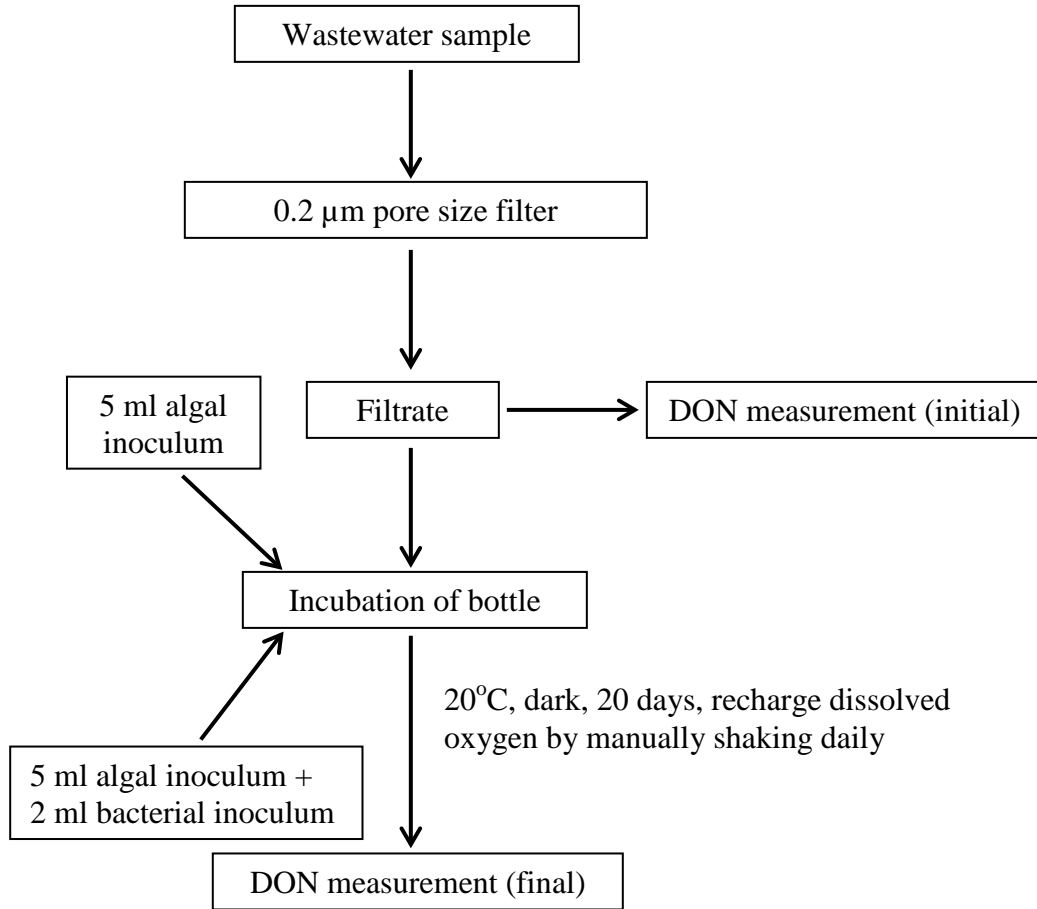

Figure 5.3. Schematic diagram of the ABDON procedures (modified from Simsek et al., 2012).

The incubation for ABDON determination was conducted under artificial light (two cool-white fluorescent light bulbs, 23 W and 380 mA each) with 12 hour light and 12 hour dark cycles. Light intensity during the 12 hour light cycle was 770 lux (HOBO U12-012 temp/RH/light external data logger, Onset Computer Corporation, Bourne, MA, USA). The ABDON procedure relied on the change of DON in the sample before (DON_i) and after (DON_f) a 28-day incubation period. A seed control (sample b) was prepared by adding the inoculum to DDW and treating it the same way as the sample (DON_{bi} and DON_{bf}).

ABDON was calculated according to Equation 5.1.

$$ABDON = [(DON_i - DON_f) - (DON_{bi} - DON_{bf})] \quad (5.1)$$

5.2.4. Analytical methods

All the parameters were determined in duplicate or triplicate and average values were reported. All the glassware was washed with soap, rinsed with tap water, kept in a 5% v/v hydrochloric acid bath overnight and rinsed with DDW and then autoclaved before use. The procedures for measuring ammonium, nitrite, nitrate, and TDN are presented in Section 3.2.5. After determining DIN and TDN, DON was calculated using Equation 2.1.

5.3. Results and Discussion

The profiles of TDN, DON, BDON, ABDON, and selected ratios of these parameters along the treatment trains of the Fargo and Moorhead WWTPs are presented in Figures 5.4 to 5.6. The data and error bars are based on averages and standard deviations for 5 samples collected from 5 different months.

5.3.1. Fargo WWTP

5.3.1.1. *Inorganic nitrogen species and TDN*

After the incubation, almost all of the ammonia was nitrified (remaining ammonia < 0.30 mg N/L) in all the samples seeded with bacteria and bacteria + algae while only the samples from nitrification trickling filters and secondary clarifiers were almost completely nitrified when seeded with algae alone (Figure A.1a in Appendix). The remaining ammonia concentrations after the incubation with algae seed alone were 10.32 and 4.24 mg N/L for the samples from the primary clarifiers and BOD trickling filters, respectively. This remaining ammonia in the sample is an indication that algae itself could not utilize the ammonia completely during the incubation.

Average nitrite concentration in all the samples before incubation was very low (< 0.40 mg N/L, Figure A.1b in Appendix). After the incubation, nitrite concentrations for all

the samples (seeded with bacteria, algae, or bacteria + algae) from nitrification trickling filters and secondary clarifiers were also low; almost all of the ammonia was nitrified all the way to nitrate (Figure A.1c in Appendix). For the samples from the BOD trickling filters, nitrate was a major form of nitrogen after the incubation. There were low concentrations of nitrite (1.41 to 5.82 mg N/L) in the BOD trickling filters samples after the incubation regardless of the inoculum type. Nitrite was high after the incubation for the primary clarifier samples seeded with bacteria only and algae + bacteria (23.97 and 14.95 mg N/L). A reason for this high nitrite was because DO was not adequate during the incubation to nitrify all the way to nitrate. It should be noted that this partial nitrification had no effect on DON and BDON results.

TDN concentration in the bacteria seeded samples was quite balanced before and after incubation for all the sampling locations (Figure 5.4a). Substantial discrepancies in TDN between before and after the incubation for the samples seeded with algae only and algae + bacteria were likely due to the uptake of nitrogen by algae which was much more than the uptake by bacteria. TDN after incubation was slightly lower in the algae + bacteria seeded samples compared to the algae seeded samples in all locations. However, judging from the standard deviations (error bars) associated with the data, it is very likely that they are not statistically different.

5.3.1.2. Dissolved organic nitrogen

DON profiles for the samples collected from the Fargo WWTP are presented in Figure 5.4b for both before and after incubation. Before the incubation, DON averaged at 7.67 mg-N/L in the samples from primary clarifiers and 3.33 mg N/L in the final effluent corresponding to 57% removal of DON from primary effluent by the WWTP. For the algae

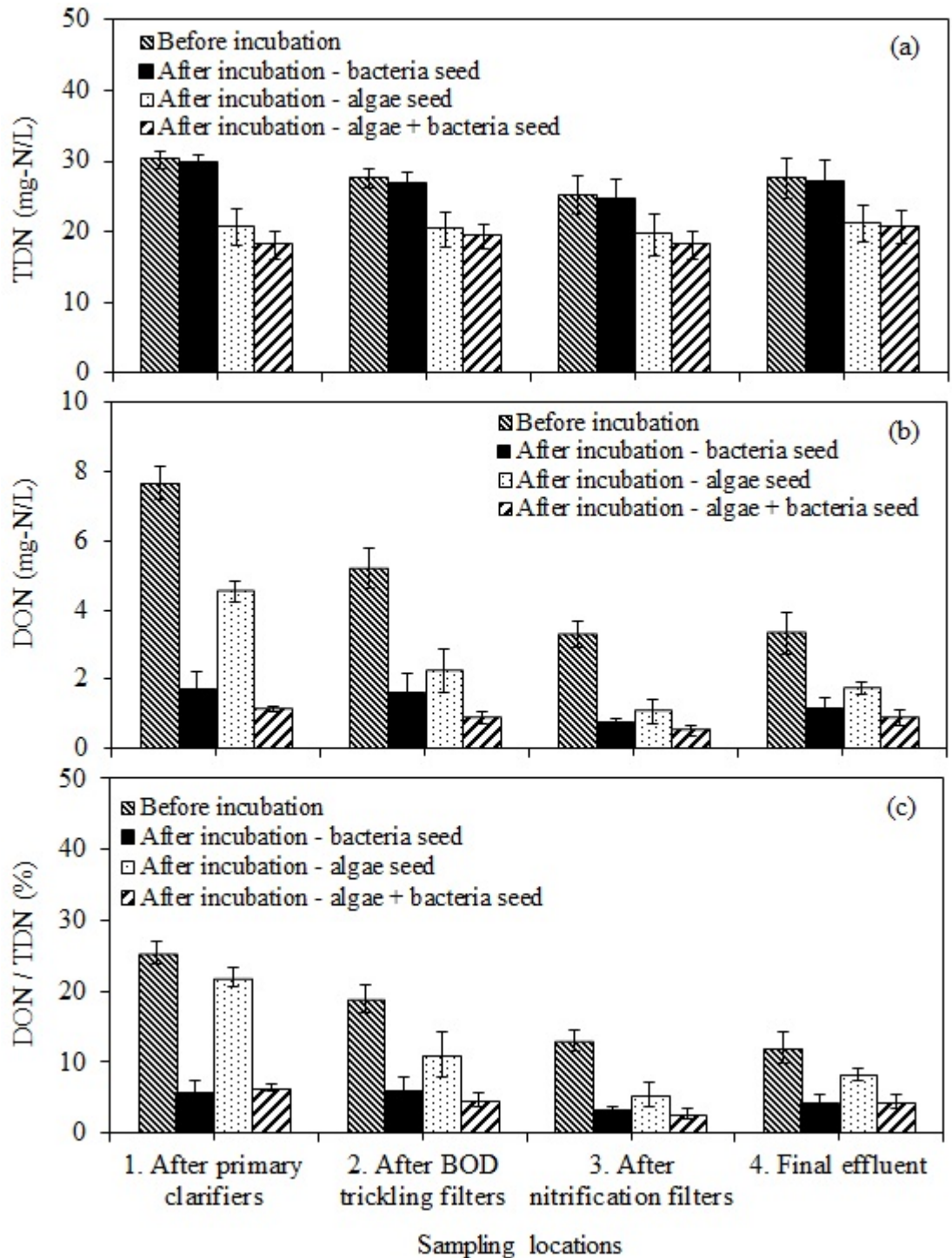

Figure 5.4. (a) TDN before and after incubation, (b) DON before and after incubation, (c) DON as a percentage of TDN before and after incubation for samples through the treatment train of the City of Fargo WWTP.

seeded samples, the remaining DON concentrations in the samples after incubation were higher than those in bacteria only and bacteria + algae seeded samples. This result showed that bacteria can ammonify and uptake (in combination) more DON than algae alone. The highest DON reduction during the incubation, indicating the highest DON bioavailability or the lowest DON recalcitrance, was observed in the samples inoculated with algae + bacteria for all samples (Figure 5.4b). Previous research showed a similar increase in effluent DON bioavailability when algae and bacteria were presented together compared to algae alone or bacteria alone (Pehlivanoglu and Sedlak, 2004; Urgan-Demirtas et al., 2008). A symbiotic relationship between algae and bacteria increased DON utilization and therefore reduced the recalcitrant DON concentration in the samples. This suggests that for water environment receiving treated wastewater, more growth of algae (potential eutrophication) might be observed if more bacteria are present.

The DON/TDN fraction data (Figure 5.4c) are very similar to the DON data (Figure 5.4 b). For the samples seeded with algae only, less DON/TDN reduction was observed during the incubation confirming limited ability of the algae to ammonify DON regardless of DON level and characteristics. Similarly, Urgan-Demirtas et al. (2008) found that only 21% of initial DON in denitrified effluent was bioavailable to algae (*S. capricornutum*) during a 14-day incubation period. Pehlivanoglu and Sedlak (2004) conducted a similar study using denitrified effluent with algae (*S. capricornutum*) and/or bacteria inocula and concluded that wastewater-derived DON was not bioavailable to algae (*S. capricornutum*) in the absence of bacteria. In this study, about 40-84% of the DON from all four locations in the Fargo WWTP was biodegradable or bioavailable to the test

species. DON reduction in algae + bacteria seed samples was the highest for all four locations.

5.3.1.3. *Biodegradable and bioavailable dissolved organic nitrogen*

BDON and ABDON concentrations decreased along the treatment train of the Fargo WWTP (Figure 5.5a). BDON removal occurred mainly in the trickling filters (locations 2 and 3). There was 65% reduction in BDON from after primary clarifier to final effluent. As expected, the order of BDON/ABDON exertion in all samples was as follows: ABDON in algae + bacteria seeded samples > BDON (bacteria seeded samples) > ABDON in algae seeded samples. Bacteria and algae together uptake and ammonify DON more than only algae or only bacteria seeds. Bacteria break down DON to lower molecular weight compounds and subsequently, algae can utilize some of those compounds (Carlsson et al., 1999; Pehlivanoglu and Sedlak, 2004).

Identifiable effluent DON usually accounts for less than 10% of DON and a major portion of DON most probably consists of polymerized biological compounds (Pehlivanoglu-Mantas and Sedlak, 2006). Previous studies showed that free amino acids, urea, and nucleic acids in DON are identifiable portions of DON and are taken up readily by bacteria and/or algae (Pehlivanoglu and Sedlak, 2004; Pehlivanoglu-Mantas and Sedlak, 2006; Urgun-Demirtas et al., 2008). The algae and bacteria are in competition for nitrate when nitrate is the only nitrogen source in the system. Bacteria use nitrate to support their growth and therefore bioavailable nitrogen source for algae decreases. These previous studies and this work show that in the presence of both nitrate and DON in the system, bacteria increase the bioavailability of nitrogen to algae since bacteria degrade DON. This reiterates the importance of bacteria on algal growth in receiving water.

Based on the BDON and ABDON results from different inoculum conditions, it is possible to identify whether algae and bacteria were utilizing (uptaking and ammonifying in combination) the same or different fractions of DON using Equation 5.2. Overlapping DON is DON that can be uptaken and ammonified by either bacteria or algae.

$$\text{Overlapping DON} = [\text{ABDON (algae seed only)} + \text{BDON (bacteria seed only)}] - \text{ABDON (algae + bacteria seed)} \quad (5.2)$$

If algae and bacteria were utilizing totally different fractions of DON, overlapping DON should be zero (no overlap between DON utilized by algae and DON utilized by bacteria). Overlapping DON can also be used to indicate relative potential for symbiotic relationship between algae and bacteria. More overlapping DON suggests less potential for the symbiosis.

The overlapping DON was calculated for all the samples and the results are presented in Table 5.1. There was overlapping DON in all the samples indicating that there is a common portion of DON that can be utilized by either algae or bacteria. The overlapping DON was lower than BDON and ABDON (algae seed only) suggesting that there were portions of DON that can be used strictly by bacteria and strictly by algae which can be calculated by subtracting overlapping DON from BDON and ABDON (algae seed only), respectively. These portions of DON which exist for both bacteria and algae are also shown in Table 5.1. DON utilizable exclusively by bacteria was higher than by algae for all the samples indicating more versatility for bacteria in going after different DON species for ammonification and uptake in combination. These results suggest the benefit of having both types of seed for sample inoculation as it would predict the maximum DON that could support algae growth directly and indirectly (through ammonification by bacteria).

Table 5.1. Overlapping DON and DON utilizable exclusively by algae and bacteria for samples from Fargo WWTP.

Sample location	Overlapping DON (mg/L)	DON in mg/L utilizable exclusively by	
		Bacteria	Algae
After primary clarifier	2.49	3.39	0.58
After BOD trickling filters	2.15	1.36	0.74
After nitrification trickling filters	1.84	0.58	0.31
Final effluent	1.23	0.85	0.29

BDON/(DON before incubation) and ABDON/(DON before incubation), also known DON biodegradability and bioavailability, of the samples are presented in Figure 5.5b. In general, biodegradability and bioavailability (algae and bacteria seeded samples) tended to decrease slightly through the treatment train. The DON biodegradability trend is similar to that observed by Simsek et al. (2012) as described in Section 4.3.2. There is no conclusive trend on DON bioavailability based on algae only seed (Figure 5.5b). Although the treatment units reduced BDON and ABDON, they also removed non-BDON and non-ABDON resulting in limited changes in DON biodegradability and bioavailability among the samples. In addition, it should be noted that the fractions of BDON and ABDON of the final effluent DON (DON biodegradability and bioavailability) are still quite high (47 to 71%) implicating that major portions of discharged DON are biodegradable and bioavailable which are not good for receiving waters.

Based on the BDON and ABDON results, to minimize BDON and ABDON discharged to receiving waters, algae should be used along with bacteria in wastewater treatment particularly in polishing treatment units. As indicated in Table 5.1., the concentrations of DON utilizable exclusively by algae in the samples from nitrification trickling filters and final effluent were 11% and 12% of ABDON exerted by bacteria + algae seed (all three columns in Table 5.1 combined). With no algae based treatment, these

DON concentrations will contribute to N load as well as support algal bloom in receiving waters. These results also suggest that traditional bacteria based treatment will not be able to completely remove the portion of DON that can support eutrophication.

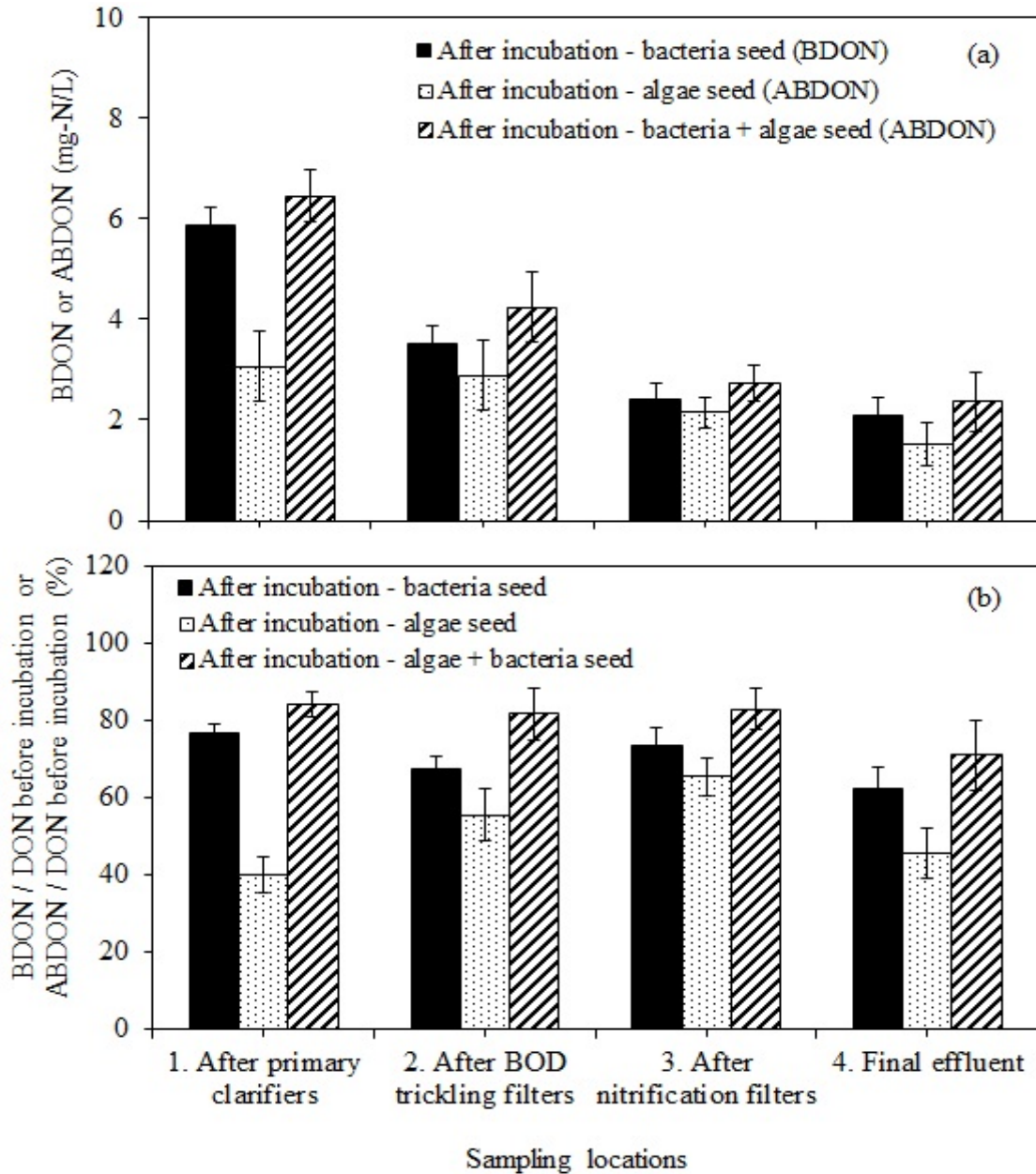

Figure 5.5. (a) Effluent BDON and effluent ABDON, (b) Effluent BDON as a percentage of effluent DON, effluent ABDON as a percentage of effluent DON for samples through the treatment train of the City of Fargo WWTP.

5.3.2. Moorhead WWTP

5.3.2.1. *Inorganic nitrogen species and TDN*

Average ammonia concentration (Figure A.2a in Appendix) after primary clarifier of the Moorhead WWTP was 27.99 mg N/L. A small decrease in ammonia concentrations (5%) was typically observed in the samples collected after secondary clarifiers. The HPO-AS process in the WWTP barely nitrified ammonia due to the toxicity of high oxygen concentration to the nitrifying microorganisms (Uemoto et al., 2000) as well as the low SRT. The MBBR process nitrified about 82% of the ammonia in the secondary effluent. The average ammonia concentration in the final effluent was 4.37 mg N/L. Similar to the Fargo WWTP results, ammonia in all the samples was totally nitrified during the incubation except for the samples seeded with algae only.

Nitrite concentrations in all samples were low (< 0.10 mg/L, Figure A.2b in Appendix). For the samples from primary and secondary clarifiers which have high ammonia concentrations, partial nitrification to nitrite was observed during the incubation for some inoculum conditions. Same as described above for the trickling filter plant, inadequate oxygen recharge during the incubation was the reason for this partial nitrification. Nitrite concentrations after the incubation in the MBBR and final effluent samples were low because of full nitrification in the MBBR and during the incubation. Corresponding to nitrite concentrations, nitrate concentrations were low for primary and secondary clarifier samples and high for MBBR and final effluent samples (Figure A.2c in Appendix).

TDN profiles for the samples collected along the treatment train are shown in Figure 5.6a. They show the same trend as the data for the Fargo WWTP. TDN

concentrations in the only bacteria seeded samples were quite balanced before and after the incubation for all the sampling locations. Very minimal TDN was removed by the HPO-AS while there was no removal by the MBBR process. For the samples that had algae in the seed, TDN concentrations were always lower compared to bacteria seeded samples confirming that algae used more nitrogen for their growth.

5.3.2.2. *Dissolved organic nitrogen*

DON profiles for the samples collected from the Moorhead WWTP for both before and after the incubation are presented in Figure 5.6b. The Moorhead WWTP samples had a higher range of DON concentrations compared to the Fargo WWTP samples (5.30 to 8.64 mg/L versus 3.33 to 7.67 mg/L). The Moorhead WWTP removed 39% of DON with the highest DON removal observed in HPO-AS at 29%. The MBBR process removed very minimal DON at 4%. The Moorhead WWTP was less efficient in removing DON than the Fargo WWTP.

After the incubation, the remaining DON in the algae seeded samples was always higher than the bacteria and algae + bacteria seeded samples for all locations. The lowest remaining DON was observed in algae + bacteria samples for all locations confirmed that algae and bacteria together can utilize more DON than bacteria only or algae only. About 25-66% of the DON from all four sampling locations were biodegradable or bioavailable regardless of the type of the inocula.

DON fraction in TDN gradually decreased along the treatment train (Figure 5.6c). About 15% of TDN in the final effluent was DON which was slightly higher than the value for the Fargo WWTP (12%). DON to TDN ratio after incubation for bacteria seeded samples and bacteria + algae seeded samples did not vary that much across the sample

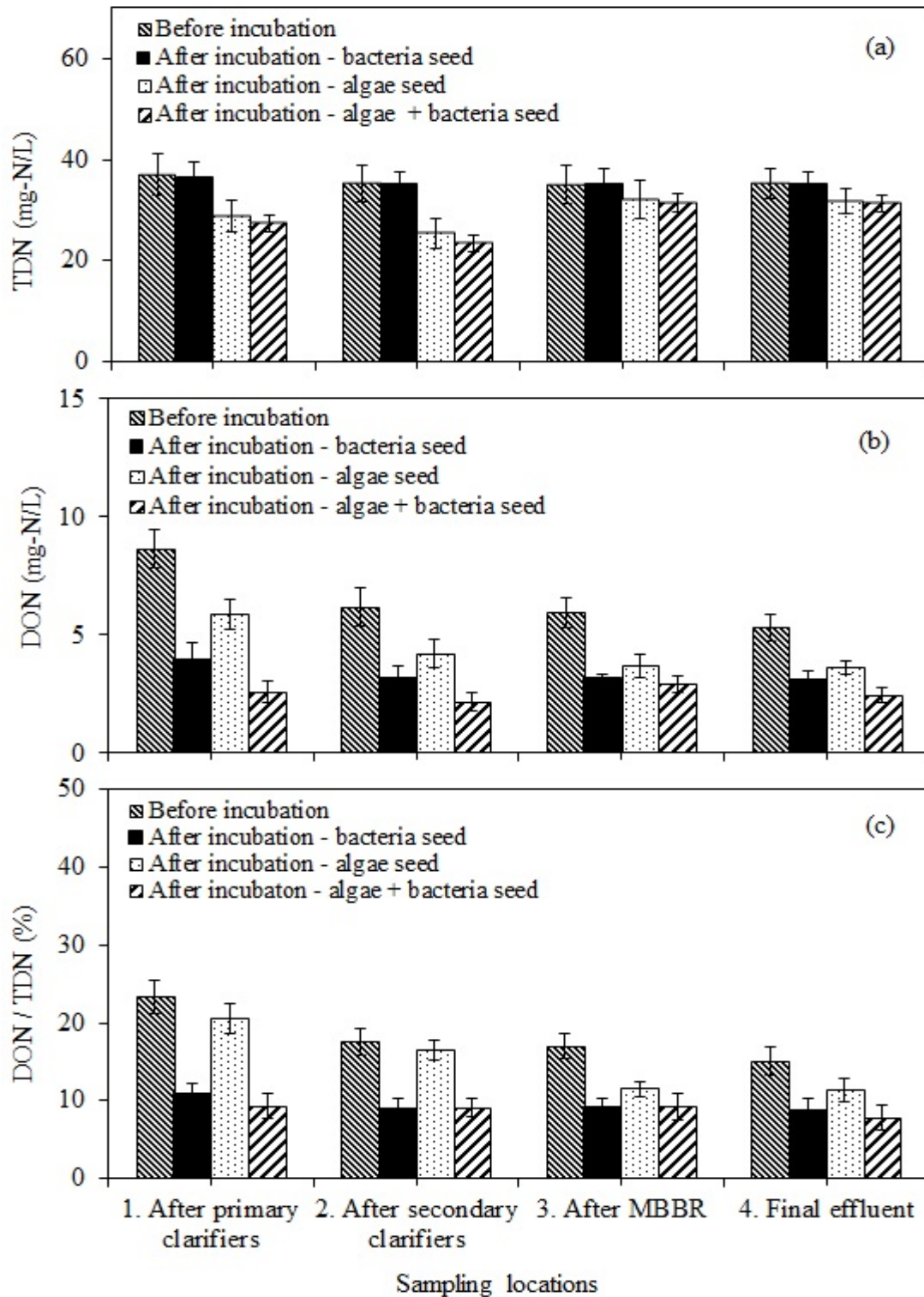

Figure 5.6. (a) TDN before and after incubation, (b) DON before and after incubation, (c) DON as a percentage of TDN before and after incubation for samples through the treatment train of the City of Moorhead WWTP.

locations ranging from 8 to 11%. For the algae seeded samples, it dropped from 22% to 8% through the plant. These trends are similar to those of the Fargo WWTP.

5.3.2.3. *Biodegradable and bioavailable dissolved organic nitrogen*

BDON and ABDON data for the Moorhead WWTP are presented in Figure 5.7a. ABDON for algae + bacteria seeded samples were always higher than BDON and ABDON (algae seeded only), same as the trend observed for the Fargo WWTP samples. BDON and ABDON were removed primarily by HPO-AS and MBBR units. BDON and ABDON (algae seed + bacteria seed) were removed more than ABDON (algae seeded only). This result, which is logical because of no or minimal presence of algae in the treatment facility, was similarly observed for the Fargo WWTP but not as dramatic. BDON and ABDON slightly increased after the polishing pond which could be due to changes in DON characteristics induced by environmental processes such as photodegradation (Bronk et al., 2010). It should be noted that chlorination and dechlorination were not practiced during the sampling period. The levels of final effluent BDON and ABDON for the two WWTPs studied were in a similar range.

The overlapping portion of DON and DON utilizable exclusively by algae and bacteria for samples from the Moorhead WWTP were calculated and the results are presented in Table 5.2. The overlapping DON values were substantially lower for the Moorhead WWTP compared to those for the Fargo WWTP particularly for the first three sampling locations. There is no trend in the overlapping DON along the treatment train. DON utilizable exclusively by bacteria and by algae was higher for the Moorhead WWTP. DON utilizable exclusively by algae was comparable with that by bacteria for the last two sampling locations and was 24% and 27% of ABDON exerted by bacteria + algae seed.

This result reiterates the importance of algae as wastewater treatment organisms especially for DON removal.

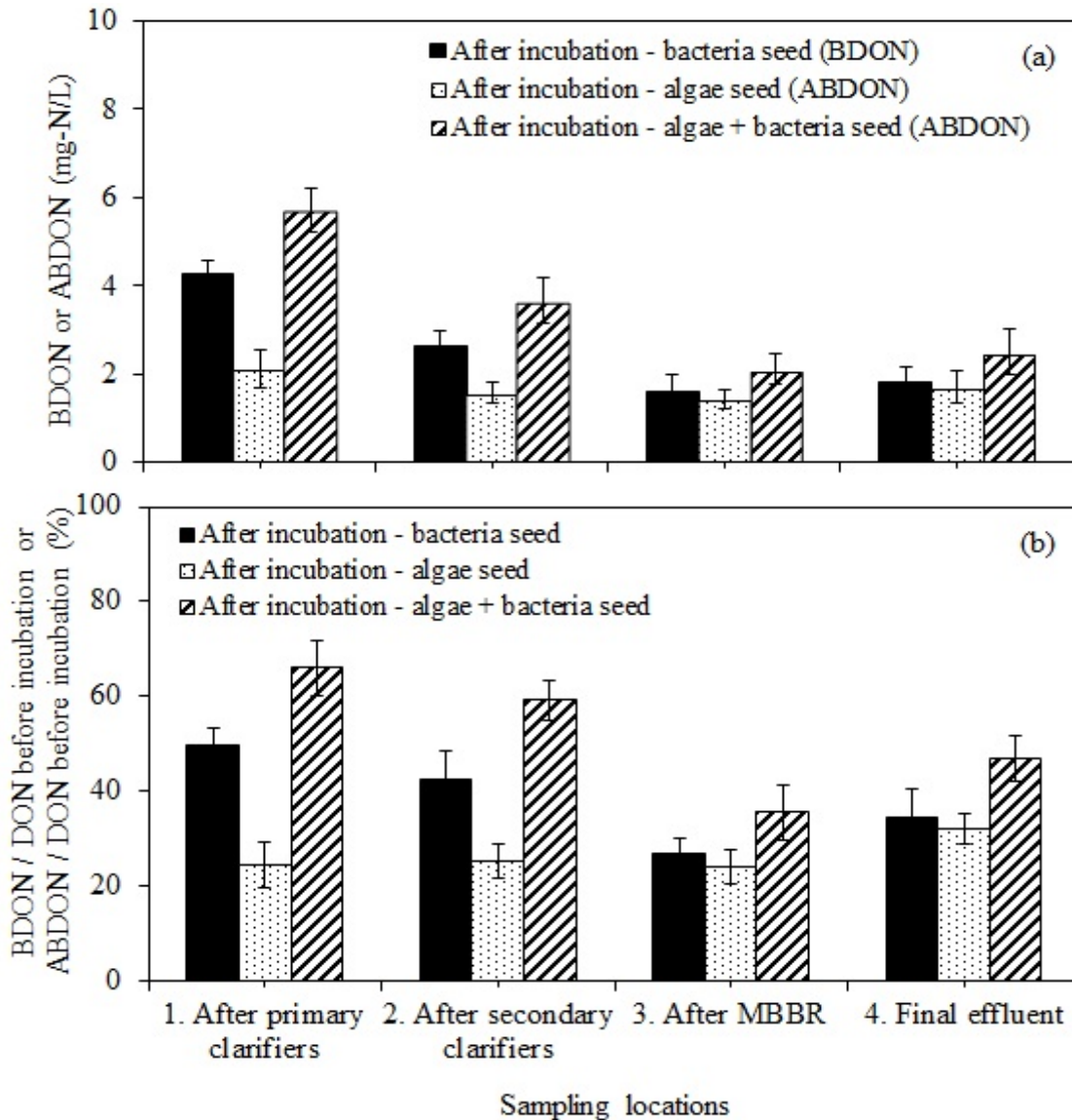

Figure 5.7. (a) Effluent BODN and effluent ABDON, (b) Effluent BODN as a percentage of effluent DON, effluent ABDON as a percentage of effluent DON for samples through the treatment train of the City of Moorhead WWTP.

BODN degradability (BODN/DON before incubation) and ABDON degradability (ABDON/DON before incubation) data are presented in Figure 5.7b. The DON biodegradability and bioavailability of the Moorhead WWTP was much lower than those

of the Fargo WWTP. This is also true for the final effluent and is mainly due to higher DON for the Moorhead WWTP but comparable BDON and ABDON between the two WWTPs. Increases in DON biodegradability and bioavailability between the last two locations were due to slight increases in BDON and ABDON as discussed above but a slight decrease in DON (Figure 5.6b).

Table 5.2. Overlapping DON and DON utilizable exclusively by algae and bacteria for samples from Moorhead WWTP.

Sample location	Overlapping DON (mg/L)	DON in mg/L utilizable exclusively by	
		Bacteria	Algae
After primary clarifier	0.69	3.59	1.42
After secondary clarifier	0.53	2.09	1.03
After MBBR	0.92	0.67	0.51
Final Effluent	1.03	0.79	0.67

5.4. Summary

A comprehensive study was conducted to investigate the fate of BDON and ABDON through treatment train of two different WWTPs, one with activated sludge + MBBR process (Moorhead WWTP) and the other one with a two-stage trickling filter system (Fargo WWTP). A combination of bacterial and algal seeds always provided the highest DON reduction (ABDON exertion) compared to bacterial only seed and algal only seed and therefore should be used to determine the worst case scenario of the impact of effluent DON on receiving waters. Both biological processes studied were not distinctively different in their abilities for BDON and ABDON removal. However, the TF plant was better in DON reduction than the AS plant resulting in effluent with higher DON bioavailability and biodegradability (ABDON/DON and BDON/DON ratios). A certain fraction of wastewater DON was utilizable by algae only suggesting the use of algae as an additional group of organisms in the treatment train particularly at the tertiary level in

order to minimize reactive DON load and in turn reduce eutrophication potential in receiving water environment.

**CHAPTER 6. BIODEGRADABLE AND PHOTODEGRADABLE DISSOLVED
ORGANIC NITROGEN IN WASTEWATER: ASSOCIATION
CHARACTERIZATION AND QUANTIFICATION**

6.1. Introduction

Wastewater treatment plants discharge effluents that normally contain significant amounts of DON into surface waters. Because of its complexity, effluent DON may not be readily bioavailable to some or all bacterial, algal, and phytoplankton species in the aquatic environment. However, photodegradation of DON in WWTP effluent provides biologically available nitrogen-rich labile compounds which could contribute to eutrophication in receiving waters (Bronk et al., 2010). It is essential to quantify the amount of PDON in wastewater effluent, which can breakdown in the presence of natural light in receiving waters.

Bushaw et al. (1996) studied the photochemical conversion of DON in humic substances from estuary to biologically available components. Humic substances are biologically refractory, high-molecular-mass components; however, exposure to sunlight causes humic substances to release nitrogenous compounds. They experimented with natural sunlight and artificial light (DEST Heraus solar simulator, 860 Wm^{-2} for the 200-3,000 nm wavelength range normalized to absorption coefficient at 350 nm) for different exposure times from 4.8 to 72 hours. Ammonium was photochemically released from all the samples during the exposure regardless of the type of light source (natural versus artificial). They concluded that exposure time and initial concentration of humic substances affect the photodegradation efficiency of DON and PDON is up to 20% of the total DON in coastal waters.

Bronk et al. (2010) investigated photochemical release and subsequent PDON production of EON from two enhanced nutrient removal WWTPs. Grab samples of the effluent prior to UV disinfection were collected from the two WWTPs and were named as EON4 and EON5. The samples were exposed to natural sunlight for 0 (control), 9, and 33 hours. Significant photoproduction of NH_4^+ and DPA were observed from both EON4 and EON5 samples, but NO_2^- release was observed only in EON4 samples.

There has been no study that thoroughly investigates a relationship between BDON and PDON. It is not known whether photodegradable portion of DON is BDON and/or non-BDON (NBDON). There could be an overlap between PDON and BDON. This overlapping portion of DON is more problematic in water environment because it has more chance to be decomposed (by photodegradation or biodegradation or both) particularly to ammonia and/or nitrite (and eventually nitrate) which could support eutrophication. This common portion of DON should be minimized by WWTPs to reduce the potential impact of effluent DON on receiving waters. Quantifying this portion of DON and understanding what WWTPs do to it are the first step towards that.

Only one study has been conducted on the photodegradation of wastewater derived DON by Bronk et al. (2010) and only final effluent samples were experimented to determine photolabile compounds released from DON by light exposure. The study did not determine if any portion of PDON was also biodegradable or not. This chapter presents a comprehensive experimental study that was conducted to provide an understanding about a relationship between PDON and BDON in wastewater. Primary treated wastewater and final effluent from two-stage trickling filter and activated sludge combined with MBBR WWTPs were the types of wastewater investigated.

6.2. Material and Methods

6.2.1. Sample source and plant description

Grab samples were collected from the City of Fargo WWTP, and the City of Moorhead WWTP. Detailed descriptions of the Fargo and Moorhead WWTPs are presented at sections 4.2.1 and 5.2.1, respectively. For both plants, two types of samples were collected, primary treated wastewater and final effluent. About 1.5 L of samples were collected from each location. Sampling was performed 2 to 3 weeks apart on six different occasions during the winter months (November to March).

6.2.2. Sample preparation

All the samples from both WWTPs were filtered through a 0.2 μm pore-size hydrophilic polyethersulfone membrane filter (Pall Co., Port Washington, NY, USA). Samples with high solid concentrations (primary treated wastewater) were filtered through a 1.2 μm pore-size Whatman glass microfibre filter (Whatman Inc., Kent, UK) prior to the 0.2 μm polyethersulfone membrane filtration. The filtered samples were autoclaved for 15 minutes to remove any remaining bacteria. Light exposure was started immediately after the samples were filtered and autoclaved.

6.2.3. Inocula collection and preparation

Bacterial inocula for BDON determination were collected from the Fargo and Moorhead WWTPs and used to inoculate their respective samples. Raw wastewater sample was used as a bacterial inoculum for the Fargo WWTP samples. The Fargo WWTP recycles settled solids from intermediate and final clarifiers and hence, the influent wastewater contains a representation of mixed bacterial culture in the treatment facility.

For the samples from the Moorhead WWTP, diluted MLSS (10 fold dilution of approximately 2,500 mg suspended solids/L) were used as a bacterial inoculum.

6.2.4. Experimental setup and operation

UV light experiments were conducted using 400 mL of samples from each location in 500 mL quartz beakers, which were used to allow more the majority of UV to penetrate. The quartz beakers were covered with parafilm and aluminum foil to prevent any evaporation. All the quartz beakers were placed on an orbital shaker and agitated at 80 rpm during the light irradiation and the shaker was turned off automatically when the UV light was off for dark cycle. All the experiments were conducted at room temperature (20°C). Two UV lamps (290 nm and 15 W each, radiation intensity at a distance of 1 m is 0.5 W m⁻² for each lamp, Universal Light Source Inc., San Francisco, CA) were attached to clamp holders in parallel along the two sides of the beakers. UV lamps were placed about 30 cm away from the samples.

The light exposure was 10 hours per day for 3 or 6 consecutive days. For the rest of the 14 hours in a day, the samples were kept in the dark. This light exposure pattern was to simulate day and night conditions which the wastewater effluent is exposed to in receiving waters. The reason for choosing 3 and 6 days of light exposure is to allow enough time for degradation of organic nitrogen in the samples. UV light exposure time in previous studies varied from 6 h to 19 days (Bushaw et al., 1996; Bushaw-Newton and Moran, 1999; Vähätalo and Järvinen, 2007; Bronk et al., 2010). Light exposure of more than 6 days (7, 9 and 12 days) was conducted at the beginning of the study (data not shown) and the DON degradation results were barely different from the 6-day exposure results.

6.2.5. DON and BDON determinations

Thirty milliliters of the filtered and autoclaved sample were used to measure dissolved $\text{DNH}_3\text{-N}$, $\text{DNO}_2\text{-N}$, $\text{DNO}_3\text{-N}$, and TDN parameters and the results were used to calculate DON_i according to Equation 2.1. DON after the incubation was determined in the same manner as DON before the incubation using Equation 2.1 and initial BDON (BDON_i) was calculated using Equation 2.3. A seed control (sample b) was prepared by adding the inoculum to DDW and treating it the same way as the sample (DON_{bi} and DON_{bf}). BDON incubation was conducted using 170 mL or 200 mL of sample and 1.7 mL or 2.0 mL of seed was added to each sample, respectively, prior to the 28-day incubation. The detailed procedure of BDON determination is described in Section 3.2.4.

6.2.6. PDON and OPBDON determinations

The procedure for PDON determination is presented in Figure 6.1. Control (dark) treatment was conducted at 20°C using 400 mL of each sample in 500 mL of amber bottles. The control was treated exactly in the same manner as the light experiment but was kept in the dark for the entire experiment. During the experiment, dissolved oxygen was recharged several times daily by manually shaking the bottles after the cap was opened for 5 minutes. After 3 days of UV light exposure, DON in the sample was determined ($\text{DON}_{\text{UV}, 3 \text{ days}}$) and consequently $\text{PDON}_{\text{UV}, 3 \text{ days}}$ was calculated using Equation 6.1. The subscript UV, 3days stands for 3 days (10 h/day) of UV light exposure.

$$\text{PDON}_{\text{UV}, 3 \text{ or } 6 \text{ days}} = (\text{DON}_i - \text{DON}_{f(\text{UV}, 3 \text{ or } 6 \text{ days})}) - [(\text{DON}_i - (\text{DON}_{f(\text{UV}, 3 \text{ or } 6 \text{ days})})]_{\text{control}} \quad (6.1)$$

Before the UV light exposure, BDON_i was determined as described earlier (in section 6.2.5). After 3 days of UV light exposure, 170 mL of sample were used for final

BDON ($BDON_f$) measurement. Overlapping photodegradable-biodegradable DON (OPBDON) values for 3 days of UV light exposure ($OPBDON_{UV, 3 \text{ days}}$) were determined

based on $PDON_{UV, 3 \text{ days}}$, $BDON_i$, and $BDON_f$ according to the following conditions:

- 1) $BDON_f = 0$ (all of $BDON_i$ is associated with PDON), $OPBDON = BDON_i$;
- 2) $BDON_f \geq BDON_i$ (all of $BDON_i$ is associated with NPDON), $OPBDON = 0$;
- 3) $BDON_f < BDON_i$ ($BDON_i$ is associated with both PDON and NPDON),

$OPBDON = (BDON_i - BDON_f)$ if $PDON > (BDON_i - BDON_f)$ or $OPBDON = PDON$ if

$PDON < (BDON_i - BDON_f)$.

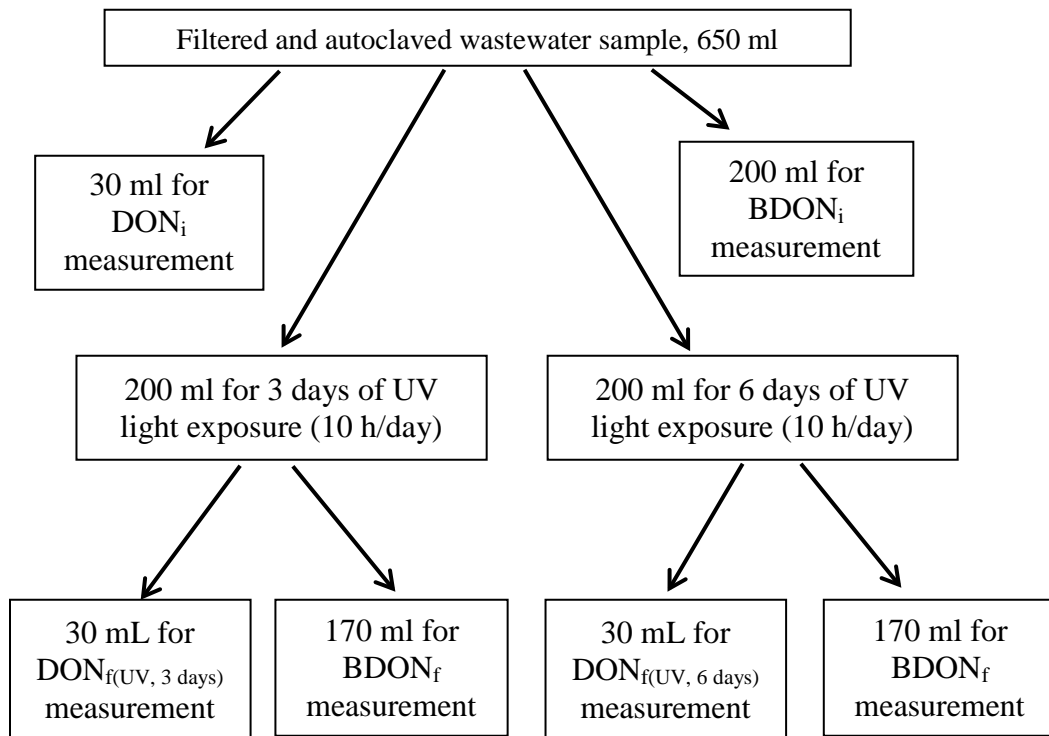

Figure 6.1. Schematic diagram of the PDON procedures.

Six day UV light experiments were conducted exactly in the same manner as the 3-day UV light experiments. $PDON_{UV, 6 \text{ days}}$ and $OPBDON_{UV, 6 \text{ days}}$ calculations were based

Equation 6.3 and conditions listed above. It should be noted that BDON_i is common for the 3-day and 6-day experiments.

6.2.7. Analytical methods

All the parameters were determined in triplicate and average values were reported. The glassware were washed with soap, rinsed with tap water, kept in a 5% v/v hydrochloric acid bath overnight and rinsed with plenty of DDW before use. The quartz bakery were additionally combusted for 2 hours at 500°C prior to use. The procedures for measuring ammonium, nitrite, nitrate, and TDN are presented in Section 3.2.5. After determining DIN and TDN, DON was calculated using Equation 2.1.

6.3. Results and Discussion

The profiles of inorganic nitrogen species, TDN, DON, BDON, PDON, OPBDON, and selected ratios of these parameters for the primary treated and final effluent samples from the Fargo and Moorhead WWTPs are presented in Figures 6.2. to 6.6. The data and error bars are based on averages and standard deviations for 6 different samples. Very minimal changes (< 1%) in the concentrations of all nitrogen parameters relative to initial levels were observed in the control treatment experiments. Regardless of their magnitude, the changes were used for the calculation of PDON (Equation 6.3).

6.3.1. Inorganic nitrogen species and TDN

During the course of experiments, no major changes in nitrate concentration were observed after 3 and 6 days of light exposure for samples from both locations of both plants (Figure A.3 in Appendix). Nitrate concentration before and after light exposure varied between 0.46 and 0.66 mg N/L and between 30.65 and 31.23 mg N/L in primary treated wastewater and final effluent samples from the Fargo plant, respectively. The

corresponding values for the Moorhead plant samples were 0.39 to 0.51 mg N/L and 23.76 to 24.02 mg N/L. These narrow variations in nitrate results before and after light exposures are evidence that nitrification did not occur or was not substantial during the light irradiation. Other researchers also did not observe any major changes on nitrate concentration during simulated or natural solar irradiations (Koopmans and Bronk, 2002; Buffam and McGlathery, 2003; Vähätalo and Zepp, 2005). After BDON incubation, nitrate concentrations in all of the samples increased because of nitrification in the samples, as expected.

Initial nitrite concentrations in all the samples from both plants were less than 0.5 mg N/L and gradually increased through 3 and 6 days of UV light exposure (Figure 6.2a). Nitrite increases were higher for the final effluent samples from both plants compared to those for the primary treated wastewater samples. These increases were from the photodegradation of DON. Kieber et al. (1999) observed nitrite production from photodegradation of humic substances isolated from coastal waters by 6 hours of sunlight exposure. In their samples, nitrite increases varied between 40% and 118%. They concluded that the initial nitrite concentration and irradiation time positively correlated to the photoproduction of nitrite. After BDON incubation, nitrite concentrations were low in the final effluent samples from both plants (< 4.15 mg N/L); however, they were higher in the primary treated wastewater samples (23.18 to 27.75 mg N/L for the Fargo plant and 23.11 to 31.92 mg N/L for the Moorhead plant, Figure A.4 in Appendix). A reason for high nitrite concentrations in the samples were because DO was not adequate during the incubation to complete nitrification. It should be noted that this partial nitrification had no effect on DON, BDON, and PDON results.

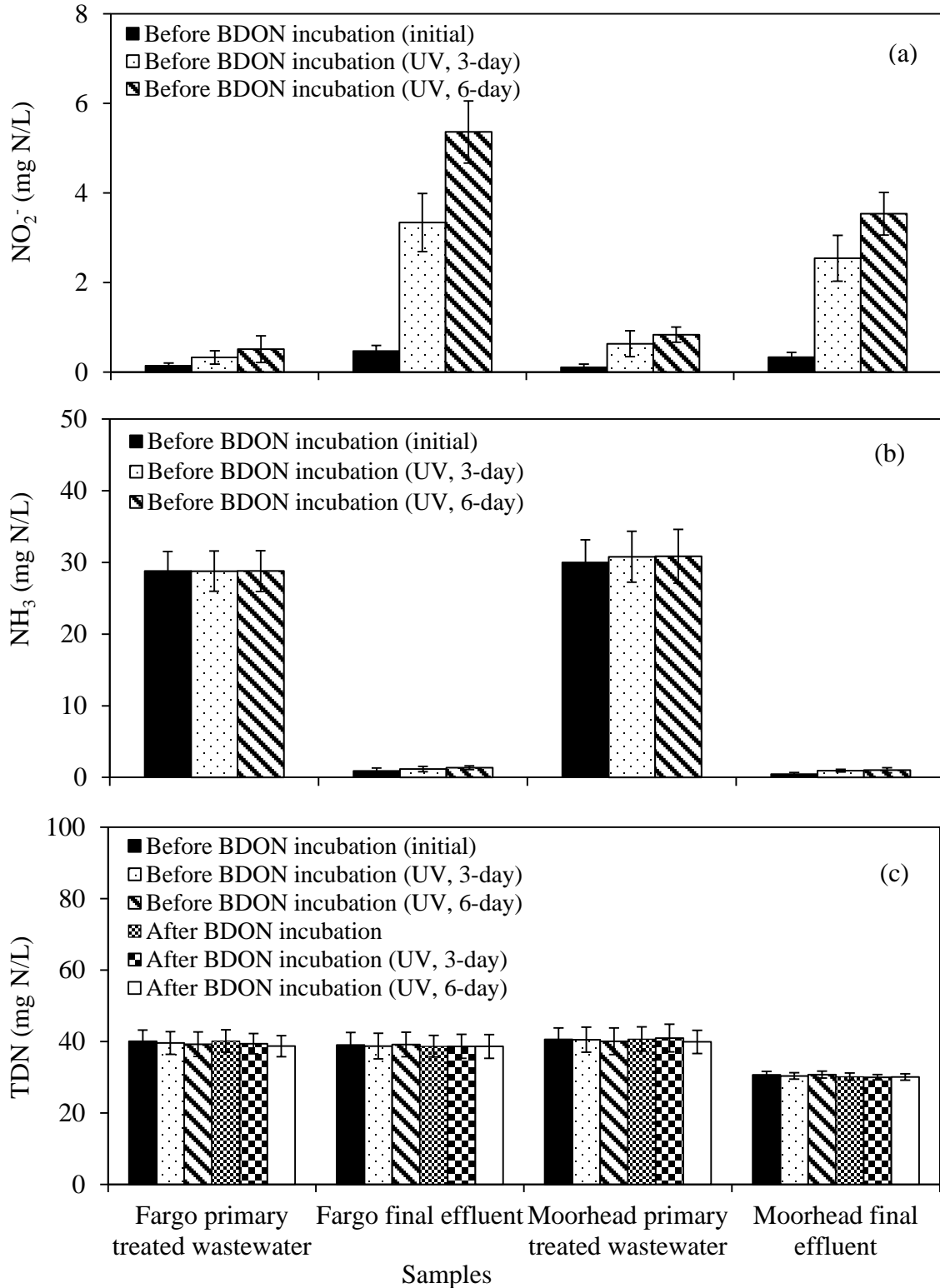

Figure 6.2. (a) Nitrite before and after UV light exposure, (b) Ammonium before and after UV light exposure, and (c) TDN before and after UV light exposure for primary treated wastewater and final effluent samples from the City of Fargo and Moorhead WWTP.

There was a limited difference in ammonium concentrations before and after the light exposure regardless of the sample type and treatment plant (Figure 6.2b). After BDON incubation, almost all of the ammonia was nitrified in all of the samples and the remaining ammonium concentrations in the samples were under the detection limits (0.02 mg N/L). Previous work on marine water samples reported substantial increases in ammonium concentration after light irradiation (Bushaw et al., 1996; Koopmans and Bronk, 2002; Vähätalo and Zepp, 2005). The reason for the lack of ammonium photoproduction (the transformation of DON to ammonium) in this study is not known. The pathway(s) for DON photodegradation have not been elucidated in previous studies.

TDN before and after light exposure, and after BDON incubation were quite balanced (Figure 6.2c). Either UV light or BDON incubation had no effect on TDN concentration. These balanced TDN indicates the reliability of the analysis and data. Khan et al. (2009) also observed TDN balances during the BDON incubation of final effluent samples from two biological nutrient removal WWTPs. It should be noted that the discrepancy between TDN concentrations in the primary treated wastewater and final effluent samples from the Moorhead plant was coincidentally due to the recycling of anaerobic digester supernatant to the head end of the plant on most of the sampling days.

6.3.2. Dissolved organic nitrogen

DON profiles for the samples collected from the Fargo and Moorhead WWTPs are presented in Figure 6.3a. DON decreased after the light exposure in all the samples from both plants. DON reduction (DON photodegradability indicator) was less for the primary treated wastewater samples suggesting that UV light was more effective in mineralizing DON in the final effluent samples. At the end of the 6 days of light irradiation, about 13%

and 72% of DON reduction was achieved in primary treated wastewater and final effluent samples in the Fargo plant while the reduction was 20% and 61% for the Moorhead plant.

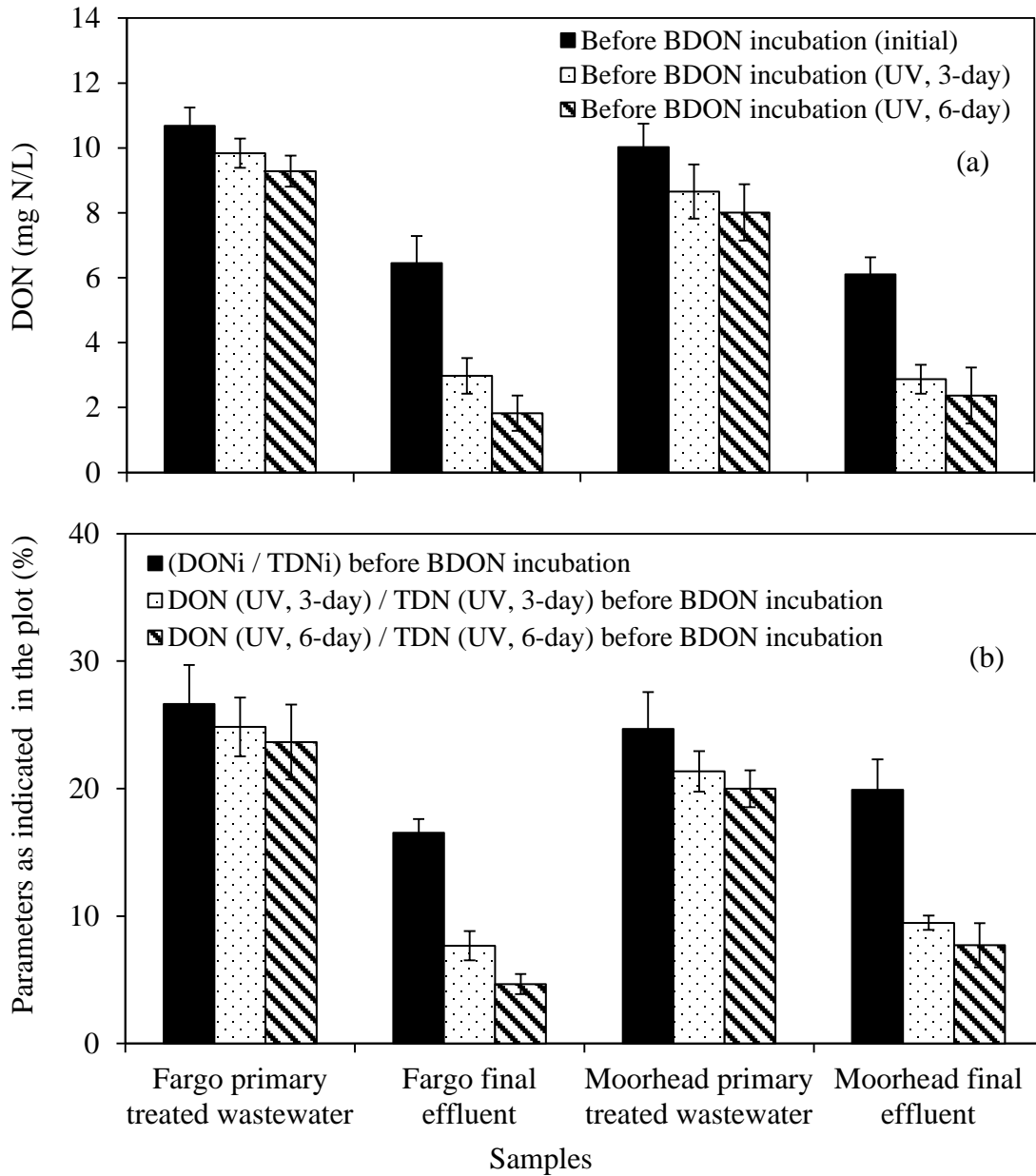

Figure 6.3. (a) DON before and after UV light exposure, (b) DON as a percentage of TDN before and after UV light exposure for primary treated wastewater and final effluent samples from the City of Fargo and Moorhead WWTP.

These results indicate that DON photodegradability between the samples from the two plants was more or less similar. After BDON incubation, DON drop was observed.

However, DON was not completely mineralized in any of the samples during the incubation and some portion of DON (NBDON) always remained in the samples.

Initial DON/initial TDN and $\text{DON}_{(\text{UV}, 3 \text{ or } 6 \text{ days})}/\text{TDN}_{(\text{UV}, 3 \text{ or } 6 \text{ days})}$ fraction data were presented in Figure 6.3b. The trends observed for these ratios were similar to DON trends in Figure 6.3a. More DON/TDN reduction in the final effluent samples for both plants after UV exposure suggests that DON in the final effluent samples was more susceptible to photodegradation.

6.3.3. Biodegradable dissolved organic nitrogen

Initial and final BDON results were presented in Figure 6.4a. From primary clarifier to final effluent, the Fargo and Moorhead plants reduced 27% and 45% of BDON, respectively. BDON_f was lower than BDON_i in all of the samples indicating that some portions of BDON were photodegraded and these portions of DON was defined as OPBDON earlier. The longer the irradiation time (6 days versus 3 days) the more BDON reduction or OPBDON ($\text{BDON}_i > \text{BDON}_{\text{UV}, 3 \text{ days}} > \text{BDON}_{\text{UV}, 6 \text{ days}}$).

DON_i biodegradability ($\text{BDON}_i/\text{DON}_i$) and DON_f biodegradability ($\text{BDON}_{\text{UV}, 3 \text{ or } 6 \text{ days}}/\text{DON}_{\text{UV}, 3 \text{ or } 6 \text{ days}}$) for primary treated wastewater and final effluent samples for both plants are presented in Figure 6.4b. The DON_i biodegradability in the Fargo and Moorhead plants was very close to each other in each location (varied between 61% and 73%). The BDON results are higher than the results obtained from a study conducted by Sattayatewa et al. (2009) in low total nitrogen effluent samples. They found 41%-43% of BDON in DON and their initial DON values were very low ($\leq 1.3 \text{ mg N/L}$) compared to DON_i in this study. $\text{BDON}_{\text{UV}, 3 \text{ or } 6 \text{ days}}/\text{DON}_{\text{UV}, 3 \text{ or } 6 \text{ days}}$ fractions in primary treated wastewater and

final effluent in the Fargo plant varied between 38% and 69%, while the variation was limited for the Moorhead plant between 55% and 58%.

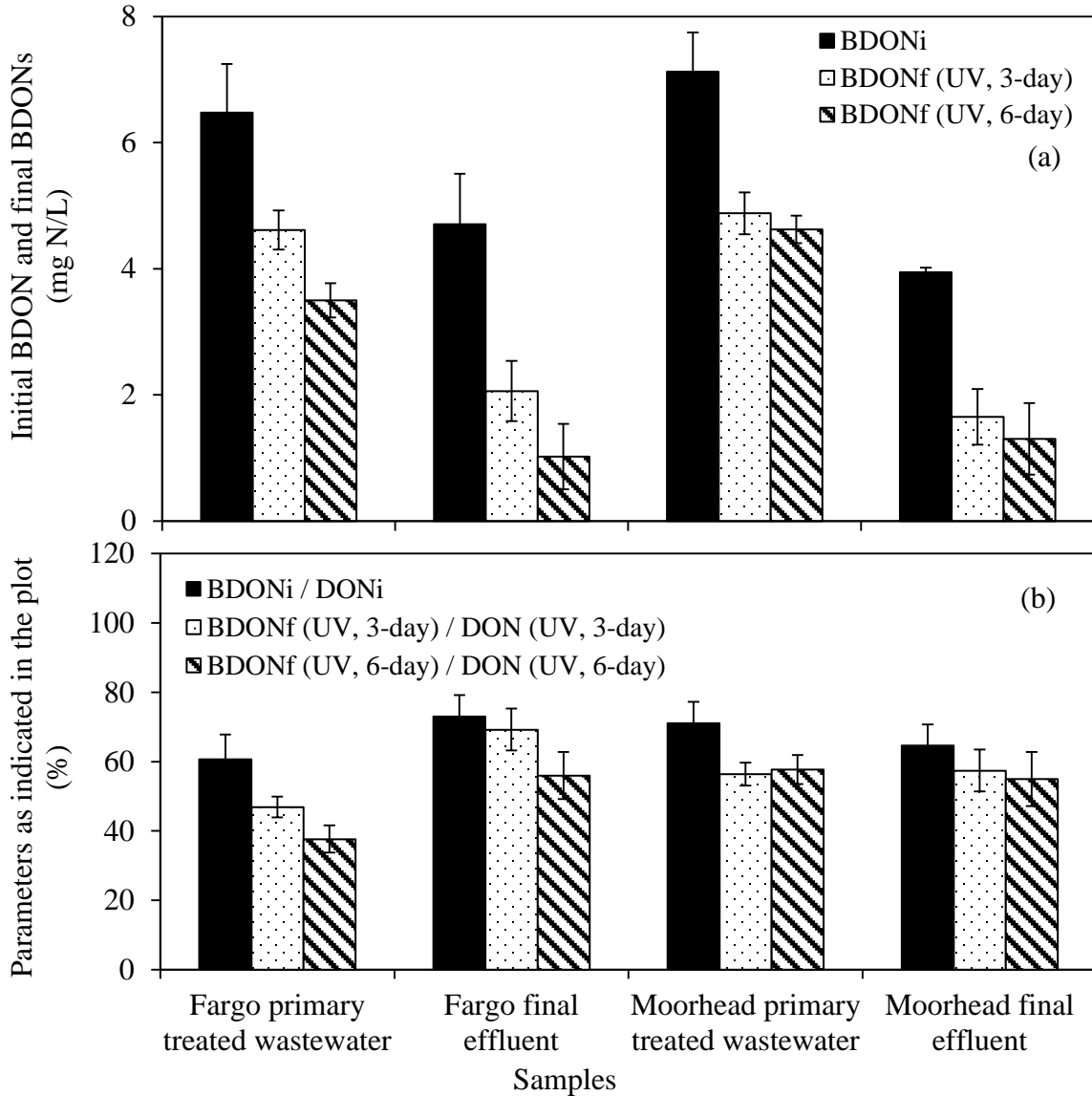

Figure 6.4. (a) BDO_i and PDON after UV light exposure, (b) BDO_i as a percentage of DON_i, PDON as a percentage of DON_i for primary treated wastewater and final effluent samples from the City of Fargo and Moorhead WWTP.

6.3.4. Photodegradable dissolved organic nitrogen

The light exposure reduced DON in the sample indicating the existence of PDON (Figure 6.5a). PDON exertion (DON reduction) increased with light exposure time. The

longer light exposure time (6-day) increased the PDON exertion (compared to 3-day exposure) about 67% and 47% in the primary treated wastewater samples and about 33% and 13% in the final effluent samples of the Fargo and Moorhead WWTPs. Selected samples were subject to 12 day light exposure to observed the trend. Very limited increases (< 12%) in PDON exertion between 6- and 12-day exposures were observed. PDON was lower in the primary treated wastewater samples compared to the final effluent samples for both plants even though DON concentration in primary treated wastewater samples was higher. The difference in PDON production in the two types of samples was likely due to the distinction in organic composition. Complex organics in the primary treated wastewater are biodegraded (by trickling filter or activated sludge) to simpler structures in the final effluent making them more photodegradable. For the first time, substantial increases of PDON after biological treatment processes are reported.

The relative amount of PDON exertion for all of the samples experimented was agreeable with the photoproduction of nitrite data (Figure 6.2a). Nitrite photoproduction increased with exposure time and was higher in the final effluent samples compared to the primary treated wastewater samples. The ammonium photoproduction results in Figure 6.2b also support the PDON exertion results although not as strongly as the nitrite data. These results suggest that substantial amounts of nitrite could be photoproduced in receiving waters. However, nitrite is not a stable form of nitrogen under aerobic conditions and the photoproduced nitrite will eventually turn into nitrate in receiving waters.

DON photodegradability ($PDON_{UV\ 3\ or\ 6\ days}/DON_i$) data for the primary treated wastewater and final effluent samples for both plants are presented in Figure 6.5b. The results are similar between the two WWTPs. DON in all of the samples was not

completely photodegradable but the photodegradability of the final effluent samples were quite high (50% to 70%) which is not desirable from the receiving water quality standpoint.

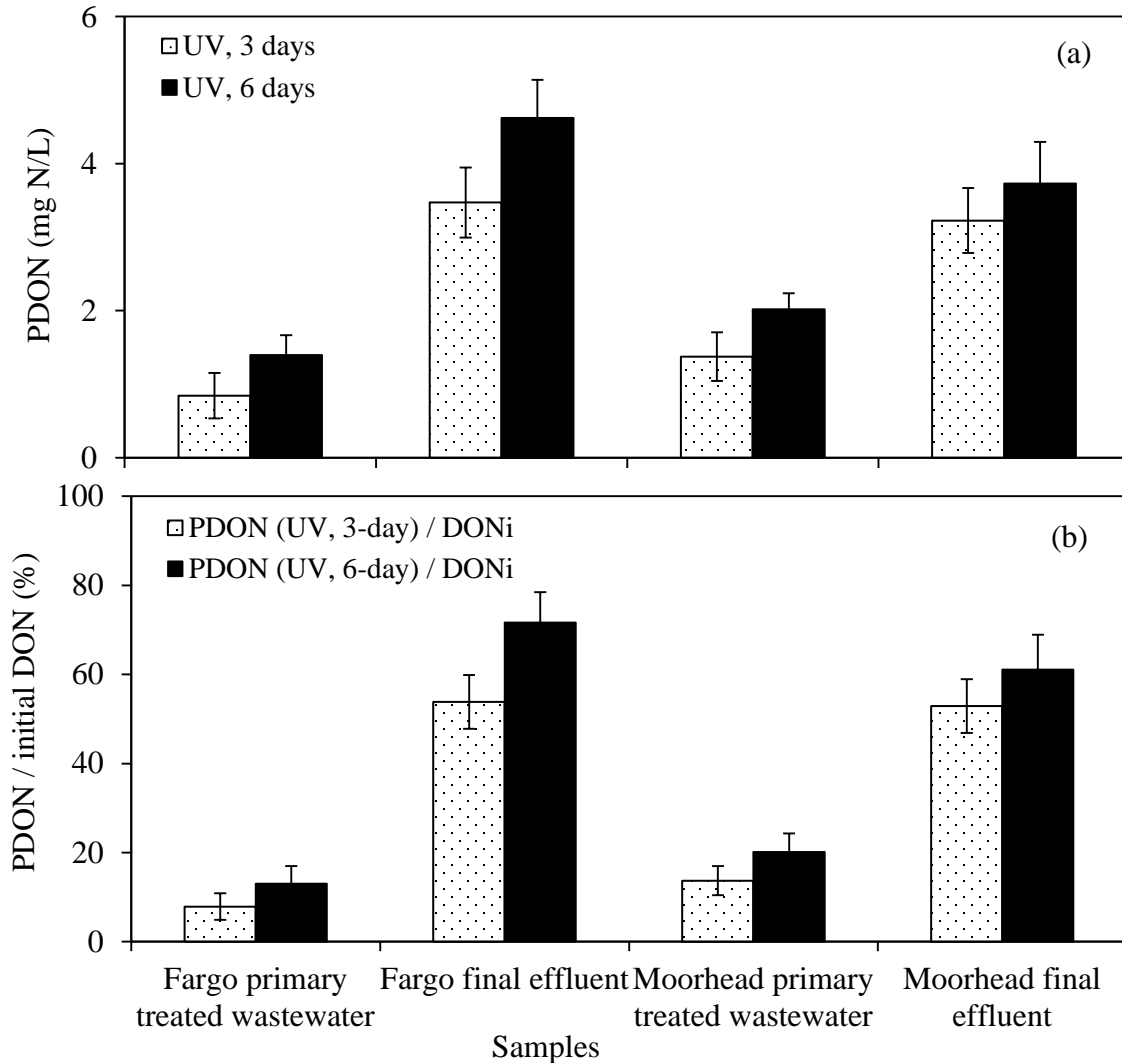

Figure 6.5. (a) PDON for 3 or 6 days of light exposure, (b) PDONs as a percentage of DON_i for primary treated wastewater and final effluent samples from the City of Fargo and Moorhead WWTP.

Treated wastewater disinfection by UV is more and more common. The practical germicidal wavelength of UV light used in disinfection is between 220 and 320 nm (Metcalf & Eddy, 2003). The contact time between UV and treated wastewater is extremely short, typically 60 seconds or less. A previous study showed that DON

degradation was not observed in the UV disinfection operation at two WWTPs (Sattayatewa et al., 2010). It was concluded that the contact time and light intensity for UV disinfection at WWTPs are not enough for DON degradation.

6.3.5. Overlapping photodegradable-biodegradable dissolved organic nitrogen

From the BDON and PDON data collected, it is possible to calculate whether PDON and BDON are overlapping (OPBDON) and this outcome provides a better understanding on the relationship between PDON and BDON. Three different scenarios for OPBDON calculations are presented above in Section 2.6. Only the third scenario (BDON_i is associated with both PDON and NPDON) was observed in this study. The third scenario has two sub-scenarios: 1) Some part of PDON is OPBDON and $OPBDON = BDON_i - BDON_f$ and 2) All of PDON is OPBDON ($OPBDON = PDON$). For both WWTPs, the data for the primary treated wastewater samples fit the second sub-scenario (Figure 6.6a) while the first sub-scenario is applicable to PDON and BDON results of the final effluent samples (Figure 6.6b). The overlapping between PDON and BDON has never been reported. Obernosterer and Benner (2004) conducted a study to determine overlapping dissolved organic carbon (DOC) using high-pressure xenon UV lamp (300 nm) as a light source on lake water samples. They found about 15% of DOC was overlapping (susceptible to both bio- and photomineralization).

The data in Figure 6.6a and 6.6b are based on 6 days of light exposure (PDON_{UV, 6 days} and BDON_{UV, 6 days}). Both the magnitudes and fractions of OPBDON in the final effluent for both WWTPs are substantial. There is no trend on the magnitudes and fractions of OPBDON between the primary treated wastewater and final effluent samples.

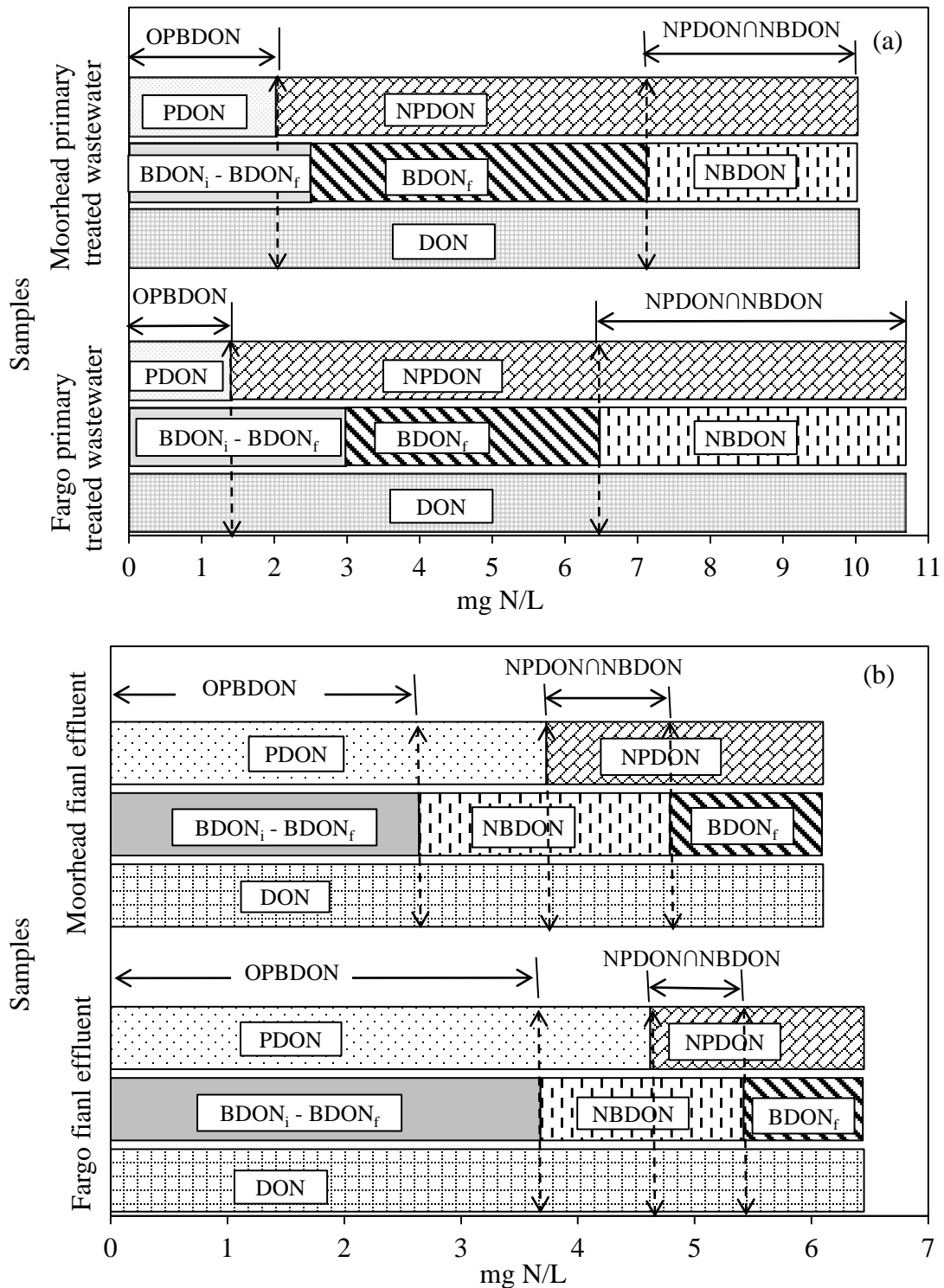

Figure 6.6. (a) OPBDON for 6 days of light exposure for primary treated wastewater samples, (b) OPBDON for 6 days of light exposure for final effluent samples from the City of Fargo and Moorhead WWTP.

For the primary treated wastewater samples, BDON is associated with NPDON more than PDON. For DON mineralization in receiving waters, light is less important than availability of microorganisms for these samples (biomineralization is controlling). For the final effluent samples, PDON is associated with both BDON and NBDON. Vähätalo and Zepp (2005) also found a similar result when they applied pretreatment to sea water samples prior to UV light exposure to remove biologically labile portion of DON. In their study, photoproduction of ammonium in the pretreated samples was observed suggesting that PDON could be associated with NBDON. Both light and availability of microorganisms are critical for the mineralization of DON in the final effluent. There is a fraction of DON that can be degraded strictly by light (PDON associated with NBDON) and DON that can be degraded only biologically (BDON associated with NPDON) exists. The results in association and magnitude relativity between PDON and BDON observed in this study agree with the biolabile and biorecalcitrant nature of the primary treated wastewater and final effluent, respectively. Based on the plots in Figure 6.6a and 6.6b, DON that is recalcitrant to both photodegradation and biodegradation (overlapping between NPDON and NBDON) can be identified ($NPDON \cap NBDON$ portion in Figure 6.6). The recalcitrant DON fraction is more for the primary treated wastewater. This recalcitrant DON fraction, although much less for the final effluent samples, is important because it will likely remain in the receiving waters for a very long period unless it is subject to chemical reactions. The fraction goes through biological treatment processes and additional photodegradation and biodegradation treatment (PDON and BDON tests) and should be considered when setting regulatory N limits (DON is not degradable or is very hard to degrade does exist).

6.4. Summary

Photochemical production of nitrite from DON was observed after exposing primary treated wastewater and final effluent samples to UV light. For both types of samples, BDON and PDON overlap, and BDON is associated with both PDON and NPDON. The absolute and relative magnitudes of PDON in the final effluent are higher than the primary treated wastewater making photomineralization more relevant. A fraction of DON that is very or truly resistant to biodegradation and photodegradation was identified in both types of samples. This study provides useful information in term of understanding the role of photodegradation of wastewater derived DON. It elucidates that light promotes eutrophication through not only photosynthesis but also photoproduction of essential nutrients.

CHAPTER 7. CONCLUSIONS AND FUTURE WORK RECOMMENDATIONS

7.1. Conclusions

A comprehensive study was conducted to investigate the fate, biodegradability, bioavailability, and photodegradability of wastewater derived DON. DON in treated wastewater has recently gained attention because DON potentially causes oxygen depletion and/or eutrophication in receiving waters. Based on the design of each experiment in this research, samples were collected from either one or more locations in one or two WWTPs, which are the Fargo WWTP with a two-stage trickling filter system and the Moorhead WWTP with an activated sludge + MBBR process. Both plants have to comply with the discharge limits for BOD and ammonium (based on the receiving river flow rate) but are not subject to any TN or total phosphorus limits.

Laboratory scale chemostat experiments were conducted at 9 different SRTs (0.3, 0.7, 2, 3, 4, 5, 7, 8, and 13 days) to examine whether SRT could be used to control DON, BDON, and DON biodegradability (BDON/DON) levels in treated wastewater. Results indicated that there was no significant trend between effluent DON and SRTs. For the 9 different SRTs, the effluent DON values varied between 4.75 and 8.08 mg N/L. Effluent BDON was comparable for SRTs of 0.3 to 4 days and had a decreasing trend at SRTs of 4 to 13 days. Operating the chemostat reactor at SRT of 7 days and above resulted in effluent DON that is close to the bioreclacitrant level which is based on DON concentration observed in the sample after 28 days of BDON incubation. A more conclusive trend was observed for effluent BDON to effluent DON ratio (effluent DON biodegradability) versus SRT. Effluent DON biodegradability ranging from 23% (at 8-day SRT) to 59% (at 0.3-day SRT) tended to decrease with SRT. This study indicates the benefit of high SRTs in term

of producing effluent with less DON biodegradability which would lead to relatively less oxygen consumption and nutrient support in receiving waters. Providing long enough time (28 days) such as in the BDON incubation, DON will be ammonified to a threshold level that only non-biodegradable DON remains in the sample.

The fate of DON and BDON in a treatment train of a two-stage trickling filter wastewater treatment system was studied. Results showed that, the treatment plant removed 27% of the influent TDN and 62% of the influent DON. The DON fraction of the plant effluent TDN was 14%. BDON was found to be between 51% and 69% of the DON in raw wastewater and after various treatment units. The plant removed 72% of BDON and discharged BDON of 1.78 mg N/L, more than 50% of the effluent DON. The removal of DON and BDON was mainly observed in the trickling filters. Seasonal differences in the BDON removal in various treatment units after the BOD trickling filters were also observed. Overall, the plant achieved higher BDON removal during the winter months. This information could be valuable for regulatory agencies when evaluating a limit on TN in the effluent from biological wastewater treatment plants. The fate of DON and BDON through the plant was modeled. BioWin v 3.1 was used to simulate inorganic and organic nitrogen species including DON and BDON through the plant. For most of the nitrogen species, the model was able to simulate with generalized kinetic and stoichiometric parameters (without the need to locally specify for each treatment process). Hydrolysis and ammonification rates for heterotrophic bacteria were the only two parameters that differed between the two stages of the trickling filter processes and needed to be adjusted. The model was found to be most sensitive to hydrolysis and ammonification rates, and maximum growth rates for AOB and NOB.

The biodegradability and bioavailability of the effluent DON in treatment trains of a two-stage trickling filter (Fargo) and an activated sludge (Moorhead) WWTPs were studied. Four sampling locations were selected for both plants and a comparison between the two plants was made on DON, BDON, and ABDON. A mixed culture bacterial inoculum was used for BDON determination, while a pure culture algal inoculum (*S. capricornutum*) and a combination of the bacterial and alga inocula were used for ABDON determination. BDON and ABDON varied significantly between the two plants. DON was an important nitrogen source for algae upon mineralization by bacteria into lower molecular weight compounds. A combination of bacteria and algae seeds reduced DON more than only algae or only bacteria seeds. Algae and bacteria worked mutually and increased the efficiency of DON reduction.

Some portions of DON are utilizable by bacteria only or algae only while there is a portion of DON utilizable by either bacteria or algae. DON reduction was the highest when both bacteria and algae were used as a co-inoculum in the samples. Both biological processes studied were not distinctively different in their BDON and ABDON removal efficiencies which were substantial. However, the TF plant was better in DON reduction than the AS plant resulting in effluent with higher DON bioavailability and biodegradability (ABDON/DON and BDON/DON ratios). A certain fraction of wastewater DON was utilizable by algae only suggesting the use of algae as an additional group of organisms in the treatment train particularly at the tertiary level in order to minimize reactive DON load and in turn reduce eutrophication potential in receiving water environment.

Photochemical degradation of DON in primary treated wastewater and final effluent samples from two-stage trickling filter (Fargo) and activated sludge (Moorhead) WWTPs was studied. Experiments were planned and performed to investigate PDON, BDON and OPBDON. Significant amount of nitrite was produced from DON by light irradiation for both types of samples from both plants. Light exposure and bioassay results showed that BDON and PDON fractions were more or less the same in both types of samples for both plants and this outcome suggests that photodegradation of DON is important as much as biodegradation of DON in wastewaters. Additionally, these results proved that light promotes eutrophication through not only photosynthesis but also photoproduction of essential nutrients.

The magnitude and fraction of PDON were higher in the final effluent samples compared to primary treated wastewater samples. About 72% and 61% of the final effluent in TF and AS treatment plants samples can potentially be photodegraded in the receiving waters, respectively. For both types of samples, BDON and PDON overlap, and BDON is associated with both PDON and NPDON. OPBDON, which was more problematic in the receiving waters since it can be decomposed by either bacteria or light, was also higher in the final effluent samples (57% in the TF plant and 43% in the AS plant). Fractions of DON in both types of samples from both plants were not biodegradable (NBDON) by bacteria and photodegradable (NPDON) by light irradiation. This refractory DON ($\text{NPDON} \cap \text{NBDON}$) was 10% to 20% of total DON and should be considered to be excluded from the effluent total nitrogen discharge limit. This research determined a portion of DON that was photochemically recalcitrant but bioreactive as well as a portion of DON that was biorecalcitrant but photoreactive. This research is the first that elucidates

association characterization and quantification of PDON, BDON, NBDON, and NPDON in wastewater.

7.2. Recommendations for Future Work

In addition to issues addressed in this research, there are topics that require further investigation and are recommended for future studies as follows.

- Elucidating wastewater DON, BDON, ABDON, and PDON chemical compositions to further understand their fate in wastewater facilities and receiving waters and possible control strategies should be attempted.
- ABDON based on other species such as periphyton that might be more available in aquatic systems compared to pure culture alga *S. capricornutum* should be measured.
- A photochemical experiment on biorefractory wastewater samples (without or very minimal BDON) obtained by applying a bioassay incubation is recommended for future work to confirm that PDON can be produced from NBDON.
- A photochemical study on samples from ENR treatment plants should be conducted. It might give different results on photodegradability of DON since ENR systems produced effluent with higher percentages of DON (relative to DIN).
- A study on algae or phytoplankton growth in photodegraded wastewater samples is recommended for further understanding of the role of photodegradation on eutrophication potential.
- PDON experiments can be conducted for longer than 6 days and daily measurement of DIN in the samples might be helpful in elucidating photochemical production and evolution of ammonium and nitrite.

- For light experiments, bacteriological analyses (measuring the bacterial growth) can be conducted to examine how photodegradation of wastewater derived DON stimulates the biomass production.

REFERENCES

- Amon, R.; Benner, R. (1996) Bacterial utilization of different size classes of dissolved organic matter. *Limnol. Oceanogr.*, 41, 41–51.
- APHA; AWWA; WEF (1998) Standard Methods for the Examination of Water and Wastewater, 20th ed.; American Public Health Association, Washington, DC.
- APHA; AWWA; WEF (2005) Standard Methods for the Examination of Water and Wastewater, 21st ed.; American Public Health Association, Washington, DC.
- Bauer, J. E.; Williams, P.M.; Druffel, E. R. M. (1992) C-14 activity of dissolved organic carbon fractions in the north-central Pacific and Sargasso Sea. *Nature*, 357, 662–670.
- Berman, T.; Bechemin, C.; Maestrini, S. Y. (1999) Release of ammonium and urea from dissolved organic nitrogen in aquatic ecosystems. *Aquat. Microb. Ecol.*, 16 (3), 295–302.
- Bilyk, K.; Takács, I.; Rohrbacher, J.; Pitt, P.; Latimer, R.; Dold, P. (2008) Full-scale dynamic testing advances fundamental understanding of denitrification filters. Proceedings of the Water Environment Federation 81st Annual Technical Exhibition & Conference, Chicago, Illinois.
- Bronk, D. A.; See, J. H.; Bradley, P.; Killberg, L. (2006) DON as a source of bioavailable nitrogen for phytoplankton. *Biogeosci. Discuss.*, 3, 1247–1277.
- Bronk, D. A.; Roberts, Q. N.; Sanderson, M. P.; Canuel, E. A.; Hatcher, P. G.; Mesfioui, R.; Filippino, K. C.; Mulholland, M. R.; Love, N. G. (2010) Effluent organic nitrogen (EON): Bioavailability and photochemical and salinity-mediated release. *Environ. Sci. Technol.*, 44 (15), 5830–5835.
- Buffam, I.; McGlathery, K. J. (2003) Effect of ultraviolet light on dissolved nitrogen transformations in coastal lagoon water. *Limnol. Oceanogr.*, 48, 723–734.
- Bushaw, K. L.; Zepp, R. G.; Tarr, M. A.; Schulz-Jander, D.; Bourbonniere, R. A.; Hodson, R. E.; Miller, W. L.; Bronk, D. A.; Moran, M. A. (1996) Photochemical release of biologically labile nitrogen from aquatic dissolved organic matter. *Nature*, 381, 404–407.
- Bushaw-Newton, K. L.; Moran, M. A. (1999) Photochemical formation of biologically available nitrogen from dissolved humic substances in coastal marine systems. *Aquat. Microb. Ecol.*, 18, 285–292.
- Carlsson, P.; Graneli, E.; Segatto, A. Z. (1999) Cycling of biologically available nitrogen in riverine humic substances between marine bacteria, a heterotrophic nanoflagellate and a photosynthetic dinoflagellate. *Aquat. Microb. Ecol.*, 18 (1), 23–36.

- Coffin, R. B. (1989) Bacterial uptake of dissolved free and combined amino acids in estuarine waters. *Limnol. Oceanogr.*, 34, 531–542.
- Eiroa, M.; Kennes, C.; Veiga, M. C. (2005) Simultaneous nitrification and formaldehyde biodegradation in an activated sludge unit. *Bioresource Technol.*, 96 (17), 1914–1918.
- Evans, E. A.; Ellis, T.; Gullicks, H.; Ringelestein, J. (2004) Trickling filter nitrification performance characteristics and potential of a full-scale municipal wastewater treatment facility. *J. Environ. Eng.*, 130, 1280–1288.
- Filippino, K. C.; Mulholland, M. R.; Bernhardt, P. W.; Boneillo, G. E.; Morse, R. E.; Semcheski, M.; Marshall, H.; Love, N. G.; Roberts, Q.; Bronk, D. A. (2011) The bioavailability of effluent-derived organic nitrogen along an estuarine salinity gradient. *Estuaries Coasts*, (34), 269–280.
- Geller, A. (1983) Degradability of dissolved organic lake water compounds in cultures of natural bacterial communities. *Arch. Hydrobiol.*, 99, 60–79.
- Grady, C. P. L., Jr.; Daigger, G. T.; Lim, H. C. (1999) *Biological Wastewater Treatment*, 2nd ed., Marcel Dekker, Inc., New York, New York.
- Graneli, E.; Moreira, M. O. (1990) Effects of river water of different origin on the growth of marine dinoflagellates and diatoms in laboratory cultures. *J. Exp. Mar. Biol. Ecol.*, 136, 89–106.
- Hanaki, K.; Wantawin, C.; Ohgaki, S. (1990) Effects of the activity of heterotrophs on nitrification in a suspended-growth reactor. *Water Res.*, 24 (3), 289–296.
- Henze, M.; Grady, C. P. L.; Gujer, W.; Marais G. V. R.; Matsuo, T. (1987) *Activated Sludge Model No. 1*. IAWPRC Scientific and Technical Report no. 1, London, United Kingdom.
- Henze, M.; Gujer, W.; Mino, T.; Matsuo, T.; Wentzel, M. C.; Marais, G. V. R.; Loosdrecht, V. (1999) Activated sludge model No 2D, ASM2D. *Water Sci. Technol.*, 39 (1), 165–182.
- Jones, R.; Takács, I. (2004) Modeling the impact of anaerobic digestion on the overall performance of biological nutrient removal wastewater treatment plants. Proceedings of the Water Environment Federation 77th Annual Technical Exhibition & Conference, New Orleans, Louisiana.
- Khan, E.; Babcock, R. W. Jr.; Suffet, I. H.; Stenstrom, M. K. (1998) Method development for measuring biodegradable organic carbon in reclaimed and treated wastewaters. *Water Environ. Res.*, 70 (5), 1025–1032.

- Khan, E.; Awobamise, M.; Jones, K.; Murthy, S. (2009) Method development for measuring biodegradable dissolved organic nitrogen in treated wastewater. *Water Environ. Res.*, 81 (8), 779–787.
- Kieber, R. J.; Li A; Seaton, P. J. (1999) Production of nitrite from the photodegradation of dissolved organic matter in natural waters. *Environ. Sci. Technol.*, 33, 993–998.
- Koopmans, D. J.; Bronk D. A. (2002) Photochemical production of dissolved inorganic nitrogen and primary amines from dissolved organic nitrogen in waters of two estuaries and adjacent surficial groundwaters. *Aquat. Microb. Ecol.*, 26 (3), 295–304.
- Loh, A. N.; Brand, L. E.; Ceilley, D. W.; Charette, M.; Coen, L.; Everham III, E. M.; Fugate, D. C.; Grizzle, R. E.; Milbrandt, E. C.; Riegl, B. M.; Foster, G.; Provost, K.; Tomasello, L. L.; Henderson, P.; Breier, C.; Liu, Q.; Watson, T.; Parsons, M. (2011) Bioavailability and Sources of Nutrients and Linkages to Nuisance Drift Algae. Final Technical Report. The City of Sanibel in Partnership with Lee County, Sanibel, Florida.
- Lomas, M. W.; Rumbley C. J.; Glibert P. M. (2000) Ammonium release by nitrogen sufficient diatoms in response to rapid increases in irradiance. *J. Plankton Res.*, 22, 2351–2366.
- Makina, J.; Pagilla, K. R.; Czerwionka, K.; Stensel, H. D. (2011) Modeling organic nitrogen conversions in activated sludge bioreactors. *Water Sci. Technol.*, 63 (7), 1418–1426.
- Metcalf & Eddy (2003) Wastewater Engineering: Treatment and Reuse, 4th Ed., McGraw-Hill, New York, New York.
- Mitch, W. A.; Sedlak, D. L. (2002) Factors controlling nitrosamine formation during wastewater chlorination, *Water Sci. Technol.*, 2 (3), 191–198.
- Moran, M. A.; Hodson, R. E. (1990) Bacterial production on humic and nonhumic components of dissolved organic carbon. *Limnol. Oceanogr.*, 35, 1744–1756.
- Moran, M. A.; Zepp, R. G. (1997) Photochemical formation of biologically labile compounds from dissolved organic matter. *Limnol. Oceanogr.*, 42, 1307–1316.
- Mulholland, M. R.; Love, N. G.; Pattarkine, V. M.; Bronk, D. A.; Canuel, E. (2007) Bioavailability of Organic Nitrogen from Treated Wastewater. STAC (Chesapeake Bay Program Scientific and Technical Advisory Committee) Report, 07–001.
- Murthy, S. N.; Jones, K.; Baidoo, S.; Pagilla, K. R. (2006) Biodegradability of dissolved organic nitrogen: Adaptation of the BOD test. Proceedings of the Water Environment Federation 79th Annual Technical Exhibition & Conference, Dallas, Texas.

- Nam, S. N.; Amy, G. (2008) Differentiation of wastewater effluent organic matter (EfOM) from natural organic matter (NOM) using multiple analytical techniques. *Water Sci. Technol.*, 57 (7), 1009–1015.
- O’Shaughnessy, M.; Harvey, G. B.; Sizemore, J.; Murthy, S. N. (2006) Influence of plant parameters on effluent organic nitrogen. Proceeding 79th Annual Water Environment Federation Conference & Exposition, 3417–3423.
- Obernosterer, I.; Benner, R. (2004) Competition between biological and photochemical processes in the mineralization of dissolved organic carbon. *Limnol. Oceanogr.*, 49, 117–124.
- Pagilla, K. R.; Sattayatewa, C.; Urgun-Demirtas, M.; Baek, S. (2011) Effect of influent nitrogen speciation on organic nitrogen occurrence in activated sludge process effluents. *Water Environ. Res.*, 83 (8), 761–766.
- Parkin, G. F.; McCarthy, P. L. (1981a) Sources of soluble organic nitrogen in activated-sludge effluents. *J. Water Pollut. Control Fed.*, 53 (1), 89–98.
- Parkin, G. F.; McCarty P. L. (1981b) Production of soluble organic nitrogen during the activated sludge treatment. *J. Water Pollut. Control Fed.*, 53 (1), 99–112.
- Pehlivanoglu, E.; Sedlak, D. L. (2004) Bioavailability of wastewater- derived organic nitrogen to the alga *Selenastrum capricornutum*. *Water Res.*, 38, 3189–3197.
- Pehlivanoglu-Mantas, E.; Sedlak, D. L. (2006) Wastewater-derived dissolved organic nitrogen: Analytical methods, characterization, and effects: A review. *Crit. Rev. Environ. Sci. Technol.*, 36, 261–285.
- Pehlivanoglu-Mantas, E.; Sedlak, D. L. (2008) Measurement of dissolved organic nitrogen forms in wastewater effluents: Concentrations, size distribution and NDMA formation potential. *Water Res.*, 42 (14), 3890–3898.
- Peterson, B.; Gernaey, K.; Henze, M.; Vanrolleghem, P. A. (2003) Calibration of activated sludge models: a critical review of experimental designs. In: Agathos, S.N. and Reineke, W. Editors, *Biotechnology for the Environment: Wastewater Treatment and Modelling*. Waste Gas Handling, Kluwer Academic Publishers, Dordrecht, Netherlands.
- Sattayatewa, C.; Pagilla, K. R. (2008) Nitrogen species measurement in low total nitrogen effluents. Proceedings of the Water Environment Federation 81st Annual Technical Exposition & Conference, Chicago, Illinois.
- Sattayatewa, C.; Pagilla, K. R.; Pitt, P.; Selock, K.; Bruton, T. (2009) Organic nitrogen transformations in a 4-stage Bardenpho nitrogen removal plant and bioavailability/biodegradability of effluent DON. *Water Res.*, 43 (18), 4507–4516.

- Sattayatewa, C.; Pagilla, K. R.; Sharp, R.; Pitt, P. (2010) Fate of organic nitrogen in four biological nutrient removal wastewater treatment plants. *Water Environ. Res.*, 82, 2306–2315.
- Seitzinger, S. P.; Sanders, R. W. (1997) Contribution of dissolved organic nitrogen from rivers to estuarine eutrophication. *Mar. Ecol. Prog. Ser.*, 159, 1–12.
- Seitzinger, S. P.; Sanders, R. W. (1999) Atmospheric inputs of dissolved organic nitrogen stimulate estuarine bacteria and phytoplankton. *Limnol. Oceanogr.*, 44 (3), 721–730.
- Seitzinger, S. P.; Harrison, J. A.; Dumont, E.; Beusen, A. H. W.; Bouwman, A. F. (2005) Sources and delivery of carbon, nitrogen, and phosphorus to the coastal zone: An overview of global nutrient export from watersheds (NEWS) models and their application. *Global Biogeochem. Cycles*, 19 (4), GB4S01.
- Simsek, H.; Kasi, M.; Wadhawan, T.; Bye, C.; Blonigen, M.; Khan, E., (2012) Fate of dissolved organic nitrogen in two stage trickling filter process, *Water Res.*, 46 (16), 5115–5526.
- Thurman, E. M. (1985) *Organic Geochemistry of Natural Waters*. Martinus Nijhoff/Dr. W. Junk Publishers, Boston, Massachusetts.
- Tranvik, U. (1988) Availability of dissolved organic carbon for planktonic bacteria in oligotrophic lakes of differing humic content. *Microb. Ecol.*, 311–322.
- Uemoto, H.; Ando, A.; Saiki, H. (2000) Effect of oxygen concentration on nitrogen removal by *Nitrosomonas europaea* and *Paracoccus denitrificans* immobilized with tubular polymeric gel. *J. Biosci. Bioeng.*, 90 (6), 654–660.
- Ulteig Engineers, Inc., (2010) Facility plan for wastewater treatment facility, UEI Project No. 10.00130, Fargo, North Dakota.
- Urgun-Demirtas, M.; Sattayatewa, C.; Pagilla, K. R. (2008) Bioavailability of dissolved organic nitrogen in treated effluents. *Water Environ. Res.*, 80 (5), 397–406.
- US EPA (1993) Methods for the determination of inorganic substances in environmental samples. EPA-600/R-93/100, Cincinnati, Ohio.
- UTEX, the culture collection of algae: Web interface. Retrieved on July 20, 2011. <http://www.sbs.utexas.edu/utex/mediaDetail.aspx?mediaID=29>.
- Vähätalo, A. V.; Zepp, R. G. (2005) Photochemical mineralization of dissolved organic nitrogen to ammonium in the Baltic Sea. *Environ. Sci. Technol.*, 39, 6985–6992.
- Vähätalo, A. V.; Järvinen, M. (2007) Photochemically produced bioavailable nitrogen from biologically recalcitrant dissolved organic matter stimulates the production of

nitrogen-limited microbial food web in the Baltic Sea. *Limnol. Oceanogr.*, 52, 132–143.

Vähätalo, A. V.; Aarnos, H.; Hoikkala, L.; Lignell, R. (2011) Photochemical transformation of terrestrial dissolved organic matter supports hetero- and autotrophic production in coastal waters. *Mar. Ecol. Prog. Ser.*, 423, 1–14.

Wiegner, T. N.; Seitzinger, S. P.; Glibert, P. M.; Bronk D. A. (2006) Bioavailability of dissolved organic nitrogen and carbon from nine rivers in the eastern United States. *Aquat. Microb. Ecol.*, 43, 277–287.

Warner, A. C. I. (1956) The actual nitrogen sources for growth of heterotrophic bacteria in non-limiting media. *J. Biochem.*, 64 (1), 1–6.

WERF (2009) Sustainable Technologies for Achieving Very Low Nitrogen and Phosphorus Effluent Levels, Water Environment Research Foundation, Alexandria, Virginia.

APPENDIX

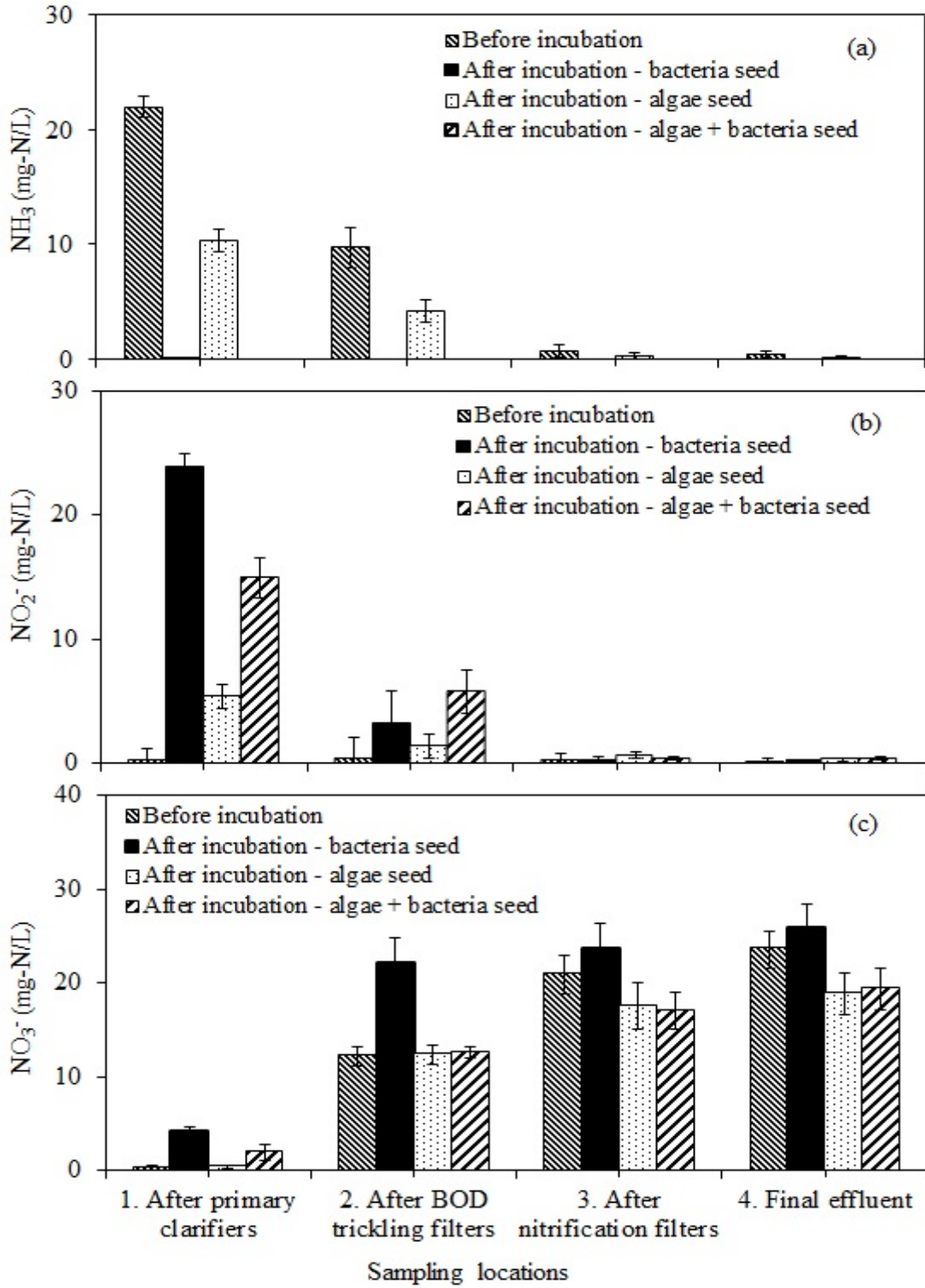

Figure A.1. (a) Dissolved ammonia, (b) Dissolved nitrite, and (c) Dissolved nitrate before and after incubation for samples from City of Fargo WWTP.

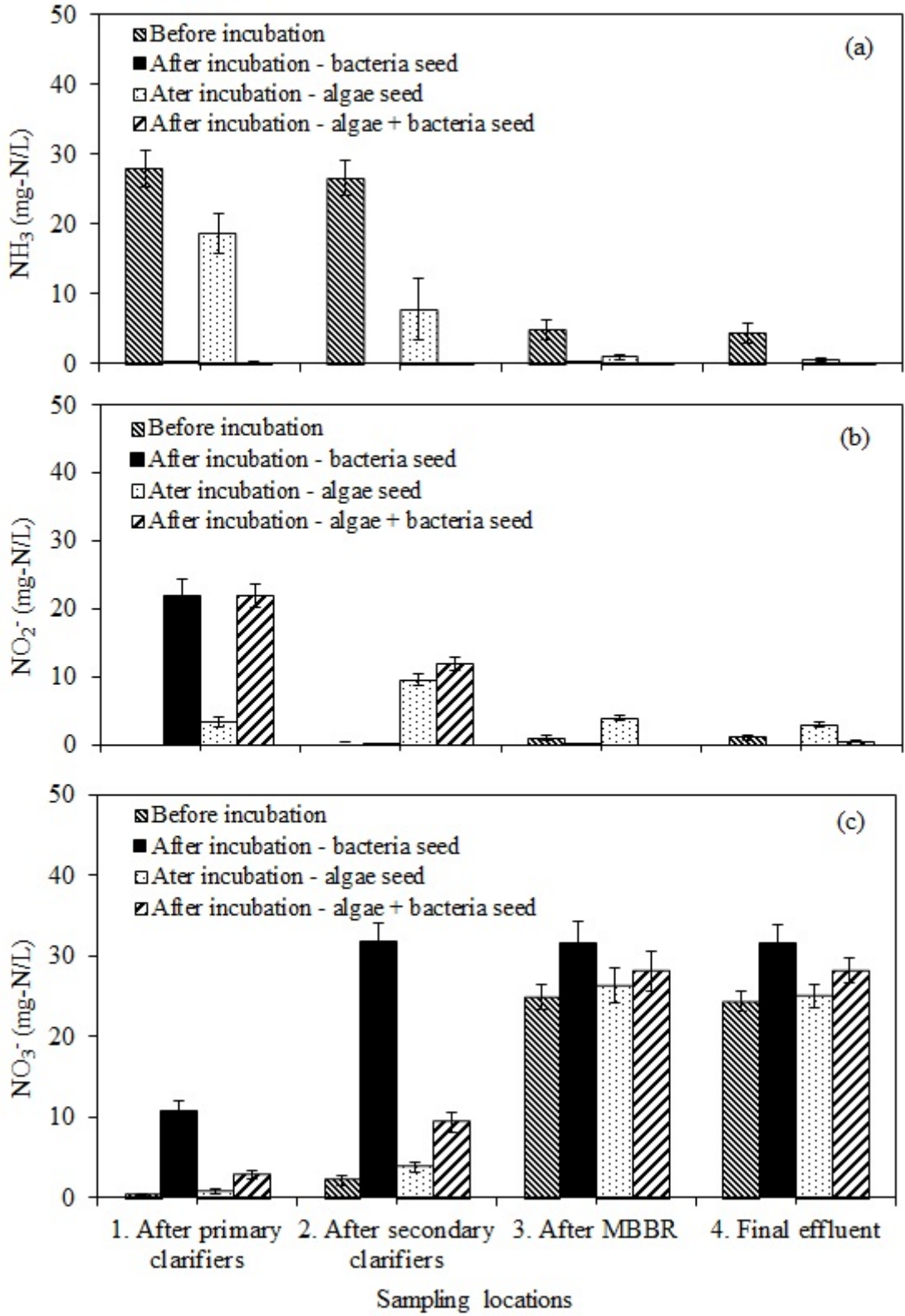

Figure A.2. (a) Dissolved ammonia, (b) Dissolved nitrite, and (c) Dissolved nitrate before and after incubation for samples from City of Moorhead WWTP.

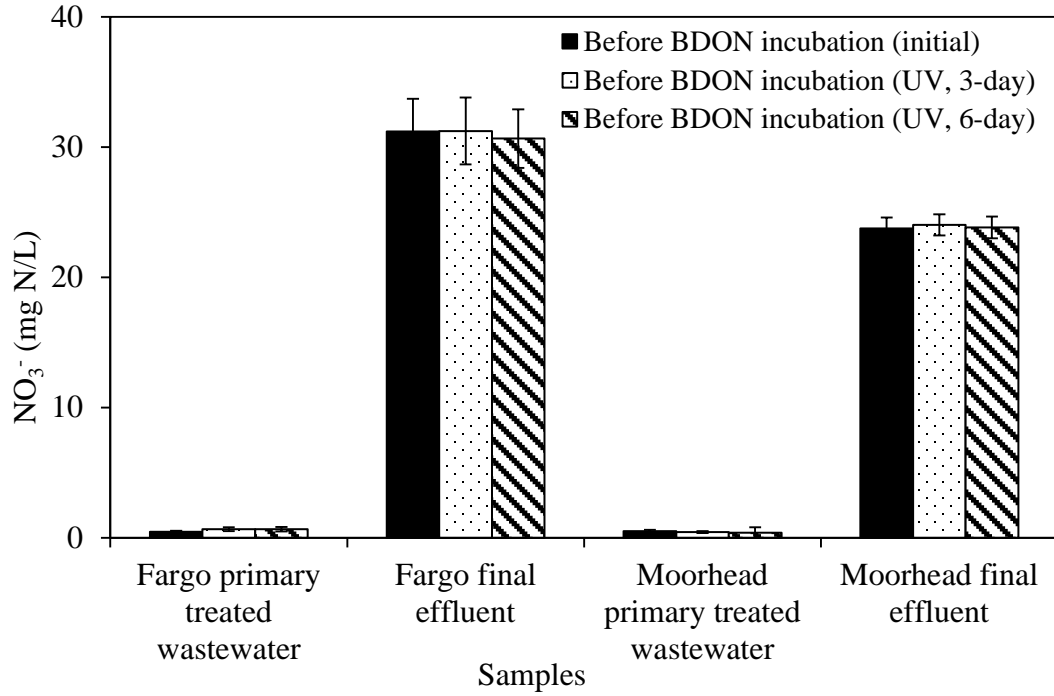

Figure A.3. Nitrate before and after UV light exposure for primary treated wastewater and final effluent samples from the City of Fargo and City of Moorhead WWTPs.

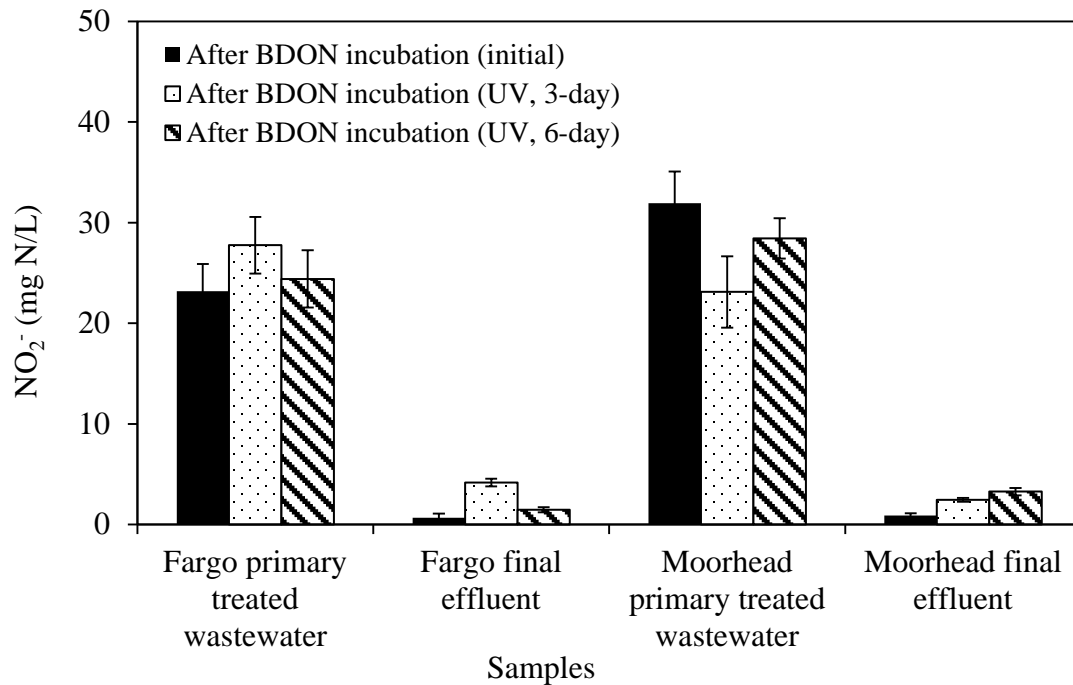

Figure A.4. Nitrite after BDON incubation for primary treated wastewater and final effluent samples from the City of Fargo and City of Moorhead WWTPs.