



<https://theses.gla.ac.uk/>

Theses Digitisation:

<https://www.gla.ac.uk/myglasgow/research/enlighten/theses/digitisation/>

This is a digitised version of the original print thesis.

Copyright and moral rights for this work are retained by the author

A copy can be downloaded for personal non-commercial research or study, without prior permission or charge

This work cannot be reproduced or quoted extensively from without first obtaining permission in writing from the author

The content must not be changed in any way or sold commercially in any format or medium without the formal permission of the author

When referring to this work, full bibliographic details including the author, title, awarding institution and date of the thesis must be given

Enlighten: Theses

<https://theses.gla.ac.uk/>
research-enlighten@glasgow.ac.uk

**THE PHYSIOLOGICAL DEMANDS OF 'HIKING'
ON DINGHY SAILORS**

by

Ioannis Vogiatzis B.Sc. M.Sc.

**A thesis submitted in fulfilment of the requirements
of the University of Glasgow for the degree of
Doctor of Philosophy**

**Institute of Biomedical and Life Sciences
University of Glasgow**

May 1995

ProQuest Number: 10390506

All rights reserved

INFORMATION TO ALL USERS

The quality of this reproduction is dependent upon the quality of the copy submitted.

In the unlikely event that the author did not send a complete manuscript and there are missing pages, these will be noted. Also, if material had to be removed, a note will indicate the deletion.



ProQuest 10390506

Published by ProQuest LLC (2017). Copyright of the Dissertation is held by the Author.

All rights reserved.

This work is protected against unauthorized copying under Title 17, United States Code
Microform Edition © ProQuest LLC.

ProQuest LLC.
789 East Eisenhower Parkway
P.O. Box 1346
Ann Arbor, MI 48106 – 1346

Herms
10165
Copy 2

GLASGOW
UNIVERSITY
LIBRARY

To my wife and my family

ABSTRACT

The purpose of the studies presented in this thesis was to combine on-water and off-water measurements in order to investigate the physiological demands of the major physical challenge in dinghy sailing: the "hiking" effort, which is performed in order to counterbalance a dinghy in moderate and stronger winds.

This purpose was achieved by:-

- 1) Investigating the course of a number of physiological variables under actual sailing conditions.
- 2) Using this information to closely simulate sailing in the laboratory.
- 3) Investigating in the laboratory a number of physiological variables which could not be studied under real sailing conditions.

On the basis of the resultant findings sailing-specific training regimes were administered to sailors to assist them in maximising hiking performance.

The use of portable telemetry allowed investigation of a number of cardiorespiratory parameters during actual sailing conditions. A series of on-water measurements revealed that aerobic capacity is only moderately taxed in dinghy sailing ($39.5 \pm 6.0\% \dot{V}O_2 \text{ max}$ at wind-speeds of between 4 and 12 ms^{-1} in 'Laser' dinghies) whereas the cardiac and respiratory functions are taxed proportionally more, thus leading to a marked tachycardia ($74 \pm 10\% \text{ HR max}$) and hyperventilation ($\dot{V}_E/\dot{V}O_2: 26.8 \pm 1.6$). Blood lactate concentration

measurements suggested that anaerobic metabolism plays an increasing role in stronger winds.

The causes of tachycardia and hyperventilation were further investigated during simulated hiking. The latter investigation offered evidence of a direct association between the onset and magnitude of fatigue in quadriceps muscle groups and the cardiovascular and ventilatory drives. The development of muscular fatigue, which was mirrored in the progressive increase in the quadriceps EMG activity, is likely to have led, directly or indirectly, to the progressive tachycardia and hyperventilation. These changes in HR, \dot{V}_E and EMG activity occurred in the absence of changes in the lactate concentration.

Further EMG measurements carried out during simulated hiking suggests that fatigue in quadriceps is due to the high degree to which these muscles were activated during hiking (approximately 30 % maximum) and that it seems reasonable to believe that local muscular fatigue is the most likely factor to limit hiking performance. Although an improvement in hiking performance was achieved after the administration of different training regimes, the present findings offer no conclusive evidence of the mechanisms responsible for resisting fatigue in quadriceps and thus maximising hiking performance. It was concluded that training regimes for sailors should not emphasise aerobic fitness but the local static endurance of the thigh muscles.

**LIST OF PUBLICATIONS EMBODYING WORK DESCRIBED IN THIS
THESIS**

1. Telemetric oxygen uptake measurements during fresh-wind dinghy sailing by national squad competitors. Vogiatzis I., Spurway N. C., Wilson J. *Proceedings of the XXXII Congress of the International Union of Physiological Sciences*, August 1st-6th, 1993: 220-221.

2. On-water oxygen uptake measurements during dinghy sailing. Vogiatzis I., Spurway N. C., Wilson J. *Journal of Sports Sciences*, 1994, **12**: 153.

3. The physiological demands of dinghy sailing. Vogiatzis I., Spurway N. C., Wilson J., Sinclair J. *Research report No 40*. Scottish Sports Council, 1995.

4. The physiological demands of dinghy sailing. Vogiatzis I., Spurway N. C., Wilson J., Sinclair J. *Research Digest No 36*. Scottish Sports Council, 1995.

5. The physiological demands of dinghy sailing at different wind velocities. Vogiatzis I., Spurway N. C., Wilson J. *Journal of Sports Sciences* 1995; **13**: 45-46.

6. Respiratory and metabolic responses during successive bouts of isometric exercise (simulated dinghy sailing) in humans. Vogiatzis I., Spurway N. C., Jennett S., Wilson J., Sinclair J. *Journal of Physiology* 1995; 483: 132 - 133 P.

7. Assessment of aerobic and anaerobic demands of dinghy sailing at different wind velocities. Vogiatzis I., Spurway N. C., Wilson J., Boreham C. *Journal of Sports Medicine and Physical Fitness* (in press, 1995).

8. Changes in ventilation in relation to changes in electromyographic activity during repetitive bouts of isometric exercise in simulated sailing. Vogiatzis I., Spurway N. C., Jennett S., Wilson J., Sinclair J. *European Journal of Applied Physiology* (submitted).

ACKNOWLEDGEMENTS

I wish to acknowledge and thank the following individuals for their contribution to the production of this thesis:

My supervisor and friend, Dr. N.C. Spurway, for the continual support, knowledge and stimulation in giving me the confidence to approach my research work positively and successfully.

Professor Sheila Jennett, for guiding me in making a large number of respiratory measurements and for maximising my passion for acquiring further knowledge.

Mr. Jim Sinclair, for producing a vast quantity of electrical and mechanical apparatus and sophisticated computer software thus enabling me to accurately investigate several aspects of dinghy sailing physiology.

Mr. John Wilson, for ensuring the smooth running of all my experiments and providing me with a great deal of knowledge on how to perform physiological measurements under exercise conditions.

Drs W. Ferrel, R. Baxendale, S. Grant and J. Reilly, for much appreciated help with non-sailing matters.

All the sailors, members of the Scottish National Squads and the University Sailing Club, for participating in my experiments and continuously motivating me to discover more about the physical demands of the sport of dinghy sailing.

Technical and administrative members of the staff of the Institute of Biomedical and Life Sciences for their assistance throughout my studies.

My friend and colleague, Mr. Y. Pitsiladis, for continuously discussing and sharing with me his scientific ideas.

Finally, financial support from the **Greek State Scholarship Foundation** is gratefully acknowledged.

CONTENTS

Abstract.....	iii
List of Publications embodying work described in this thesis.....	v
Acknowledgements.....	vii
List of Chapters.....	ix
List of Appendices.....	xvi
List of Tables.....	xvii
List of Figures.....	xviii
List of Symbols.....	xx
CHAPTER 1. INTRODUCTION	1
1.1 GENERAL INTRODUCTION.....	1
1.1.1 Evolution of racing dinghies.....	1
1.1.2 How the dinghy sails.....	2
1.1.3 Aims in racing dinghy sailing.....	3
1.1.4 Physical demands of dinghy hiking.....	5

1.2 LITERATURE REVIEW OF THE PHYSIOLOGICAL ADJUSTMENTS TO ISOMETRIC CONTRACTIONS	6
1.3 REVIEW OF STUDIES IN DINGHY SAILING.....	9
1.3.1 Physical and Physiological profiles of dinghy sailors	11
1.3.2 Physiological studies under actual sailing conditions	13
1.3.2.1 <i>Cardiovascular measurements</i>	13
1.3.2.2 <i>Gas exchange measurements</i>	15
1.3.2.3 <i>Metabolic measurements</i>	16
1.3.3 Studies under simulated sailing conditions.....	17
1.3.3.1 <i>Cardiovascular and gas exchange measurements</i>	17
1.3.3.2 <i>Metabolic measurements</i>	19
1.3.3.3 <i>Electromyographic (EMG) measurements</i>	21
1.3.4 Fitness training programmes for dinghy sailors.....	23
1.4 AREAS OF NEEDED RESEARCH IN DINGHY SAILING PHYSIOLOGY.....	24

1.5 STATEMENT OF RESEARCH PURPOSES	26
CHAPTER 2. GENERAL METHODS	28
2.1 SUBJECTS AND TESTING PREPARATION.....	28
2.2 DETERMINATION OF GAS EXCHANGE VARIABLES IN THE LABORATORY	29
2.3 DETERMINATION OF GAS EXCHANGE VARIABLES AT SEA	31
2.4 DETERMINATION OF CARDIOVASCULAR VARIABLES.....	33
2.5 DETERMINATION OF WHOLE BLOOD LACTATE CONCENTRATION.....	34
2.6 DETERMINATION OF ELECTROMYOGRAPHIC ACTIVITY.....	35
2.7 DETERMINATION OF FORCES.....	38
2.8 DETERMINATION OF ANGULAR DISPLACEMENT OF HIP AND KNEE JOINTS	39
CHAPTER 3. STUDIES UNDER ACTUAL SAILING CONDITIONS	40
3.1 INTRODUCTION.....	40

3.2 METHODS	45
3.2.1 Subjects	45
3.2.2 Study I: Accuracy, Validity and Reproducibility of the K2 System	45
3.2.2.1 Accuracy of measurements	45
3.2.2.2 Validity of $\dot{V}O_2$ measurements performed by the K2 System - Assessment of the sailors' maximum aerobic powers	46
3.2.2.3 Reproducibility of $\dot{V}O_2$ measurements performed by the K2 System	48
3.2.3 Study II: On-water measurements of cardiorespiratory parameters ...	48
3.2.4 Study III: Aerobic and anaerobic demands of dinghy sailing at different wind velocities	50
3.2.5 Statistical analyses	51
3.3 RESULTS	52
3.3.1 Study I: Accuracy, Validity and Reproducibility of the K2 System	52

3.3.1.1 Accuracy of measurements.....	52
3.3.1.2 Validity of $\dot{V}O_2$ measurements performed by K2 System - Assessment of the sailors' maximum aerobic powers.....	53
3.3.1.3 Reproducibility of $\dot{V}O_2$ measurements performed by the K2 System.....	55
3.3.2 Study II: On-water measurements of cardiorespiratory parameters.....	55
3.3.3 Study III: Aerobic and anaerobic demands of dinghy sailing at different wind velocities.....	62
3.4 DISCUSSION OF CHAPTER 3.....	68
3.4.1 Accuracy, Validity and Reproducibility of the K2 System (Study I).....	68
3.4.2 On-water measurements of cardiorespiratory parameters (Study II).....	70
3.4.3 Aerobic and anaerobic demands of dinghy sailing at different wind velocities (Study III).....	73

CHAPTER 4. STUDIES UNDER SIMULATED

SAILING CONDITIONS	77
4.1 INTRODUCTION	77
4.2 PROCEDURES AND MATERIALS	81
4.2.1 Construction and operation of the dinghy simulator	82
4.2.2 Simulation procedure	86
4.3 METHODS	87
4.3.1 Subjects	87
4.3.2 Pilot and Familiarisation Tests	88
4.3.3 Experimental protocol	89
4.3.4 Measurements of respiratory variables	89
4.3.5 Measurements of cardiovascular variables	90
4.3.6 EMG sampling and analysis	91
4.3.7 Blood sampling	92
4.3.8 Other measurements	92
4.3.9 Statistical analyses	92
4.4 RESULTS	93
4.4.1 Respiratory variables	93
4.4.2 Cardiovascular variables	97
4.4.3 EMG analysis	97
4.4.4 Blood lactate analysis	98
4.4.5 Other variables	101

4.4.6 Comparison of measurements under actual and simulated conditions	101
4.5 DISCUSSION OF CHAPTER 4	105
CHAPTER 5. LIMITATIONS ON AND TRAINING REGIMES	
TO IMPROVE HIKING PERFORMANCE.....	117
5.1 INTRODUCTION.....	117
5.2 METHODS	121
5.2.1 Subjects.....	121
5.2.2 Hiking bench	121
5.2.3 Control of the force exerted on the toe-strap.....	122
5.2.4 Control of body angles.....	122
5.2.5 Recording the EMG activity	123
5.2.6 Cardiovascular measurements	124
5.2.7 Experimental protocols.....	124
5.2.8 Training regimes	126
5.2.9 Statistical analyses	127

5.3 RESULTS	128
5.3.1 Study I	128
5.3.2 Study II	131
5.4 DISCUSSION OF CHAPTER 5	135
5.4.1 Study I	135
5.4.2 Study II	137
CHAPTER 6. GENERAL DISCUSSION	141
6.1 CONCLUSIONS	150
6.2 IMPLICATIONS FOR COACHES AND SAILORS	152
6.3 DIRECTIONS FOR FURTHER RESEARCH IN THE AREA OF DINGHY SAILING PHYSIOLOGY	156
REFERENCES	158

APPENDICES

Appendix 1: Consent form.....	I
Appendix 2: K2 apparatus.....	III
Appendix 3: Pulse rate curve.....	IX
Appendix 4: EMG apparatus.....	XI
Appendix 5: Goniometry.....	XIV

LIST OF TABLES

Table 1. Coefficients of variation for $\dot{V}O_2$ measurements performed by the K2 and DB methods.	56
Table 2. Average $\dot{V}O_2$ and HR figures derived from the nine on-water measurements on the six subjects.	57
Table 3. Average absolute values of $\dot{V}O_2$ and HR, percentages of respective maximum values, $\dot{V}_E/\dot{V}O_2$, oxygen pulse and post-test [La].	64
Table 4. Means for variables not illustrated graphically: the force exerted on the toe-strap of the simulator, the % max. IEMG activity from biceps brachii (BB), and the RPE - all recorded during the 4 hiking bouts.	102

LIST OF FIGURES

- Fig. 1.** Oxygen uptake values recorded simultaneously using the K2 and Douglas bag methods. 54
- Fig. 2.** The average $\dot{V}O_2$ and HR responses in a typical individual during alternate periods of sailing upwind and downwind. 58
- Fig. 3.** $\dot{V}O_2$ and HR responses in a representative individual during both upwind and downwind legs while sailing without competition, racing against a single boat and racing in a fleet of boats. 60
- Fig. 4.** Minute-by-minute relationship between $\dot{V}O_2$ and HR responses in a typical individual while sailing for 29 minutes. 61
- Fig. 5.** The average maximum oxygen uptake values of other high performance sailors in comparison to that measured from the Scottish sailors..... 63
- Fig. 6.** Relationship of the percentage of maximum oxygen uptake and heart rate of each subject in an on-water test to the average wind velocity. 66
- Fig. 7.** Relationship between each subject's post-test [La] and the average wind velocity for that particular test. 67
- Fig. 8.** Diagram of the dinghy simulator and a plan view of the deck and hull arrangement..... 85

- Fig. 9.** Changes over the 4 bouts and during recovery for $\dot{V}O_2$, \dot{V}_E , $\dot{V}_E/\dot{V}O_2$ and P_{ET, CO_2} 94
- Fig. 10.** Breath-by-breath records for a representative subject of partial pressure of CO_2 at the mouth and V_I 96
- Fig. 11.** \dot{V}_I and the % max. IEMG recorded from rectus femoris over each minute of each bout, expressed as changes from the first 15 s ('baseline period') of each bout..... 99
- Fig. 12.** Changes over the 4 bouts and during recovery for the % max. IEMG, the oxygen pulse ratio, HR and [La] 100
- Fig. 13.** A comparison of the average percentages of maximum values for oxygen uptake and heart rate obtained from the simulation and on-water tests in moderate and strong winds. 103
- Fig. 14.** A comparison of the average oxygen pulse ratio and ventilatory equivalent for oxygen recorded from the simulation and on-water tests... 104
- Fig. 15.** Average level of activation in four muscle groups recorded from the right and the left sides of the body during hiking performance.....130
- Fig. 16.** The average % max. IEMG activity recorded during each minute of hiking exercise from rectus femoris before and after the 7 weeks training programmes for groups A and B..... 132
- Fig. 17.** The average HR responses recorded during each minute of hiking before and after the 7 weeks training programmes for groups A and B ... 133

LIST OF SYMBOLS

ATP	Adenosine tri-phosphate
BP	Blood pressure (mmHg)
CO	Cardiac output ($l \text{ min}^{-1}$)
CP	Creatine phosphate
EE	Energy expenditure (Kcal min^{-1})
EMG	Electromyographic activity
$F_E O_2$	Percentage concentration of oxygen in the expired air
$F_I O_2$	Percentage concentration of oxygen in the inspired air
H^+	Hydrogen ions
HR	Heart rate (beats min^{-1})
IEMG	Integrated electromyographic activity
K^+	Potassium ions
[La]	Blood lactate concentration (mM)
MABP	Mean arterial blood pressure (mmHg)
MVC	Maximal voluntary contraction
P_{ET, CO_2}	End-tidal tension of carbon dioxide (kPa)
RF	Respiratory frequency (breaths min^{-1})
SV	Stroke volume
TPR	Total peripheral resistance
\dot{V}_E	Minute ventilation ($l \text{ min}^{-1}$)
$\dot{V}_E/\dot{V}O_2$	Ventilatory equivalent for oxygen
\dot{V}_I	Inspired minute volume ($l \text{ min}^{-1}$)
$\dot{V}O_2$	Minute oxygen uptake ($\text{ml kg}^{-1} \text{ min}^{-1}$)
V_I	Cumulative inspired volume

CHAPTER 1

1. INTRODUCTION

1.1 GENERAL INTRODUCTION

1.1.1 Evolution of racing dinghies

Dinghy sailing is a sport growing steadily in popularity. It is estimated that, in Britain alone, some 500,000 people sail dinghies several times each year and approximately 10 percent of these people compete seriously. Racing dinghy sailing has evolved over the past fifty years from the heavy planked open boats with unsophisticated sails in which the sailors sat upon benches. The present generation racing dinghy is made of glass reinforced plastic materials often containing layers of carbon fibre or Kevlar. Their weight is minimal, yet is combined with a rigidity that enables them to carry sophisticated rigs with spars made of stiff aluminium alloy or carbon fibre, and sails of resin impregnated synthetic fibres. They have thus the potential for great speed due to their high power to weight ratio. They also have a minimal wetted area which makes for reduced friction between hull and water and have underwater foils in the form of an adjustable centreboard to act as a 'keel' and a rudder of airfoil shape to control the direction of sailing.

1.1.2 How the dinghy sails

Wind is the dinghy's driving force. The wind flows over the '*windward*' side (towards the wind) of the sail causing pressure, and round the '*leeward*' side (opposite direction from which the wind is coming) causing suction. The resulting force on the sail is at right angles to the sail and it is this force which pushes the boat forwards but also sideways. The forwards push is welcome! The sideways push is counteracted by water pressure on the centreboard. However, the efficiency of the centreboard decreases if the dinghy is allowed to heel away from the wind since it is then presenting less lateral resistance. To prevent this heeling effect the sailor positions his/her body on the windward side of the dinghy acting as a counterbalance to the force that the wind generates when it interacts with the sail. As the wind strength increases so the counterbalance has to increase to maintain the boat upright and to keep the centreboard vertical in the water to give maximal resistance to sideways thrust. The sailor maintains the required amount of counterweight by positioning himself further and further towards the outer edge of the deck of the dinghy ('*side deck*') as the wind strength increases.

The demands for keeping the dinghy upright are particularly high when the boat is being sailed as close as possible to the direction from which the wind is coming ('*sailing upwind*'), because then the sails are pinned close to the centre

line of the boat and produce a marked sideways thrust and heeling moment. In contrast, when the wind is coming from further aft (*'sailing downwind'*), the sails are set well out from the centre line and act to push the boat almost directly forward without producing appreciable sideways thrust.

When the dinghy is being sailed upwind there comes a time, due to an increase in wind strength, when sitting upon the side deck is no longer enough to maintain the boat upright. The sailor then has to take body weight acting through his/her centre of gravity further out than the side deck will permit. There are two ways of achieving this. One is, to suspend the body from a wire attached high up on the mast - a *'trapeze'*- and virtually stand against the upper edge of the side deck. The alternative and older technique involves hooking the feet under straps attached to the bottom of the hull, supporting the back of the legs on the side deck and suspending the rest of the body over the water (*'hiking'*) thus balancing the capsizing force of the wind on the sail. In a high-performance racing dinghy hiking to the full extent of the body's length becomes necessary in winds of only $6-8 \text{ m sec}^{-1}$ (9-12 knots).

1.1.3 Aims in dinghy racing

Most dinghy races are performed around a number of marker buoys specified by the sailing or race committee and called 'the course'. There are several types of

course depending on the local geography but most are triangular or trapezoidal in shape and are intended to test both upwind and downwind sailing. The Olympic course, which is so named because it is used in the Olympic Games, used to be triangular in shape but in the 1996 Olympic Games its shape will be a trapezium. The start is across an imaginary line between two points (often a committee boat and a buoy) and is usually signalled by the lowering of a flag and the sounding of a horn or gun. All boats must be behind this line when the starting signal is made. A warning signal and preparatory signal allow competitors to start their watches and do their own countdown.

The first leg is usually upwind to the first mark and sailors often have to hike all the way up to this point. The subsequent legs are downwind, eventually finishing back near the starting area. The course is then repeated, the number of rounds being specified in the sailing instructions. The ultimate aim is to complete the race by achieving the best possible finishing position in relation to the other competitors. In other words sailors need to sail the racing course in the shortest possible time which means that they have to maximise boat velocity. This is achieved by maximising the aerodynamic power generated by the interaction of the wind with the sail. Even in strong winds, sailors still have to maintain the same maximal sail power during racing. To maintain a constant sail power while counterbalancing the resulting heeling moment, especially during sailing upwind in moderate and in strong winds, hiking is required for

extensive periods of time. The longer and more efficiently the hiking posture can be maintained then the faster the boat can be sailed.

1.1.4 Physical demands of dinghy hiking

Hiking is a form of physical exercise which differs greatly from that which predominates in almost every other sport, in that it imposes essentially static (isometric) stresses on quadriceps, abdominal and other anterior body muscle groups for periods of many minutes with only a few very short intervals of relief. (These most commonly occur when the sailor crosses the boat as in 'tacking'). Physiological studies over the last quarter-century (Assmusen 1981; Lind 1983; Rowell and O'Leary, 1990) have reported striking differences in responses to rhythmic and static modes of exercise, ascribable to their effects on blood flow through the active muscles. For example, the pumping action of rhythmic isotonic contractions increases muscle blood flow at any given perfusion pressure. Conversely, during isometric contractions, the intramuscular pressure is increased, mainly due to the inwardly-directed components of fibre tension and also due to swelling and stiffening of the active fibres within their sheaths of connective tissue. The resulting pressure is transferred to the intramuscular blood vessels and causes compression which squeezes blood out of the veins and hinders or stops the flow of blood into and within the muscles (Assmusen 1981). Therefore, there is not only an absence of muscle pumping, but also an

impedance to blood flow by the contracting muscles. Hence the cardiovascular response to isometric contractions is characterised by its failure to secure adequate blood flow to the contracting muscles once their force exceeds 10 to 15 percent of the maximal force they can develop (Lind and McNicol 1967). Failure of the local blood flow to adjust to the metabolic requirements of the muscles causes early muscle fatigue and therefore limits the time which the contraction and thus (in the present instance) the hiking posture can be adequately maintained.

1.2 LITERATURE REVIEW OF THE PHYSIOLOGICAL ADJUSTMENTS TO ISOMETRIC CONTRACTIONS

It is characteristic that heart rate (HR) increases immediately at the onset of both static and dynamic exercise - already the first few cardiac cycles are shortened (Krogh and Lindhard, 1913, for dynamic exercise). This points to a nervous origin of the reaction which is mainly associated with "central command" and vagal withdrawal involving the cardiac centres in the brain, and also involves some contribution from a reflex elicited by mechanoreceptors in the active muscles. The equally sudden fall in HR at the end of exercise, static or dynamic, likewise seems to link the HR response to the actual activity period (Rowell and O'Leary, 1990). Following the sudden increase in HR at the start of exercise, a continuous but slower further increase in HR usually occurs in

static exercise. This could be elicited by an increase in chemoreceptive signals from the ischaemic muscles. (Chemosensitive group III and IV muscle afferents are activated whenever blood flow to active muscle is restricted so that both delivery of oxygen and washout of metabolites are reduced; Rowell and O'Leary, 1990). These chemosensitive signals can change the excitatory state of the autonomic centres in the brain (medulla), thus increasing sympathetic stimulation and HR. On the other hand, an increasing local muscle fatigue will demand an increasing voluntary effort in order to maintain a constant external force. Therefore, the "central command" will undoubtedly also increase and be co-responsible for the increasing HR (Asmussen 1981).

Blood pressure (BP) also increases abruptly at the onset of isometric exercise; thereafter it continues to increase gradually while exercise is maintained, and begins to fall immediately at the end of exercise. The mechanisms responsible for the continuous rise in BP during the exercise period are the following:-

BP is proportional to the product of cardiac output (CO) and total systemic peripheral resistance (TPR); CO itself is the product of HR and stroke volume (SV). In isometric exercise HR rises initially under central command, but the later and greater additional elevation is due to chemoreflexes elicited by the intramuscular types III and IV fibres. SV may slightly decrease due to the decreased venous return, but the continuous increase in HR dominates, so CO increases steadily. On the other hand, as in dynamic exercise, inactive regions

tend to vasoconstrict due to the increased sympathetic tone which is driven centrally. However, these regions are not more-than-compensated (as they would be in dynamic exercise) by vasodilatation which is called forth in all active muscles (principally in response to local chemical stimuli) because of the elevated intramuscular pressure in the isometric case. Hence TPR rises. It is therefore because TPR and CO have both increased that diastolic BP is raised, as well as systolic BP, in isometric exercise.

The rapid decrease of BP after exercise ceases is due not only to reversal of all the above, but also probably to some general vasodilatation as metabolites flushed out from formerly-active muscles flow round the body.

Because static exercise is characterised by the failure of the local blood flow to adjust to the oxygen demands of the exercising muscles, the muscles will have to work under partly or completely ischaemic conditions. Therefore, a part of the total energy demand must be covered by anaerobic processes, e.g., breakdown of ATP, CP, and glycogen. This will create a local milieu entirely different from

that in rhythmic exercise. As the respiratory and circulatory responses to the exercise will be dominated by the fact that a steady state cannot be achieved due to the mismatch between circulation and metabolism, the work time will be short, limited (as it has been already noted) by local muscle fatigue.

Finally, the quantitative differences in oxygen uptake ($\dot{V}O_2$), minute ventilation (\dot{V}_E) and CO between the static and rhythmic kinds of activity are further consequences of the fact that active muscles in static exercise are continuously totally or partly blocked from the general circulation and therefore $\dot{V}O_2$ can be only moderately increased during the working period. This explains why at equivalent $\dot{V}O_2$ values, HR, \dot{V}_E , and especially BP are distinctly higher in static exercise (Assmusen, 1981).

1.3 REVIEW OF STUDIES IN DINGHY SAILING

Exercise scientists have always been interested in studying the stresses and functional characteristics shown by various systems and organs during sport performance, in order to supply reliable information and theories to athletes and coaches. Although a considerable amount of knowledge regarding the physiological demands of various sports has been accumulated over the last half

century, study of the physical demands of dinghy sailing in relation to other sport disciplines has attracted little attention. Probably this is mainly due to the difficulties of the sailing environment which make scientific study hard to conduct. Limitations on the use of measuring devices under actual sailing conditions, in association with the impossibility of standardising the environmental conditions, until very recently accounted for a lack of any physiological measurements other than those of HR trends (section 1.3.2.1.). The very few other on-water measurements attempted were made on a small number of sailors participating in different boat classes, and under inconsistent weather conditions, therefore limiting even more the amount of information available for the sport of dinghy sailing.

Hence, most of the data regarding the physiological demands of dinghy sailing have been gathered during laboratory sailing simulations and physical fitness surveys of elite sailors. Although such laboratory measurements have improved considerably our understanding about sailing physiology, they have lacked authority in the sailing world due to what is perceived as a less challenging environment. From the scientific standpoint they might perhaps be further criticised for their subjectively established protocols.

1.3.1 Physical and physiological profiles of dinghy sailors

The physical characteristics of dinghy sailors vary considerably with the type of the craft and their role in the boat (e.g. skippers or crews). The bigger the boat and the surface area of the sails, the greater the heeling moment which the wind generates and therefore the heavier the crew members should be in order to counterbalance the vessel. Also, when the type of the craft allows trapezing, the taller the crew member, the further out the centre of his/her body mass can be extended and therefore the more efficient the counterbalancing moment can be.

In the heaviest and the largest types of Olympic craft with the largest sail areas, the Star and the Soling, the skipper and the crew members are the heaviest and the tallest (body mass is around 100 kg and height is around 190 cm) of all sailors competing in Olympic classes (Plyley et al., 1985; Gallozzi et al., 1993). In the lighter double handed classes, the 470 and the Tornado, skippers are quite light (around 60 to 65 kg) as compared to the crew members who need to be heavier (around 75 to 85 kg) and taller (around 180 cm) for efficient trapezing (Plyley et al., 1985). In single handed classes (i.e. Finn and Laser for men, Europe for women), body size is still the most important factor for keeping the boat upright especially in strong winds; particularly so because the sailor can not be assisted by the efforts of the crew nor is he/she permitted in these classes to

trapeze. Again the size of the sail in those craft determines the minimum weight of the sailor. Because the surface of the sail in Finn dinghies is larger than in the Lasers, Finn sailors are usually heavier (around 85 to 90 kg - Plyley et al., 1985) than Laser sailors (around 70 to 75 kg - Thomas, 1991; De Vito et al., 1993; Blackburn, 1994).

Examination of the maximum $\dot{V}O_2$ scores of high performance sailors suggests that aerobic power is not of great importance to the sailor. Such scores, recorded in the literature, have ranged between 49.5 ± 6.7 ml kg^{-1} min^{-1} (mean \pm SD) for the Canadian sailing squad, and 62 ± 8 ml kg^{-1} min^{-1} for the Swedish sailing squad, respectively (Niinimaa et al., 1977; Piehl-Aulin et al., 1977). Also the fairly low percentages of slow twitch fibres (mean: 53 %, range: 41-68 %) found in quadriceps muscle groups of the high performance Swedish sailors (Piehl-Aulin et al., 1977) explained why maximum aerobic capacity was not particularly developed in those sailors.

Sailors have strong legs and abdominal muscles and their isometric strength is well developed in an attempt to diminish the cardiovascular strain involved in hiking. Knee extension forces, recorded from the Canadian sailors, were much higher than those for swimmers and even for oarsmen (Plyley et al., 1985). Muscular endurance of the leg and abdominal muscles is also one of the physical abilities well developed in sailors. Finally, flexibility is helpful for changing

positions quickly and balance is a very important attribute, particularly when sailing small craft (Shephard, 1990).

1.3.2 Physiological studies under actual sailing conditions

1.3.2.1 Cardiovascular measurements

Measuring HR was the original and fundamental approach for assessing the physiological strain of the many different activities in which sailors were employed. The study of HR trends revealed that sailing upwind was physically more demanding than sailing downwind (Piehl-Aulin et al., 1977; Pudenz et al., 1981; Bachemont et al., 1981; Harrison and Coleman 1987), thus confirming the sailors' personal impressions. More specifically it was shown that in single-handed craft (i.e. Lasers) the average HR while sailing upwind in strong winds (168 ± 12 beats min^{-1}) was substantially higher than when sailing downwind (138 ± 8 beats min^{-1} - Pudenz et al., 1981). In addition, classification of the physical strain was made accordingly to the wind velocity conditions. The distribution charts for the pulse rates showed a displacement towards higher pulse frequencies as the wind speed rose; the average HR values while sailing upwind in moderate winds (143 ± 9 beats min^{-1}) were reported to be substantially lower

than when sailing upwind in stronger winds (168 ± 12 beats min^{-1} - Pudenz et al., 1981).

HR recordings varied also according to the type of boat (single or double-handed) and the activities that sailors performed during sailing. It was shown that single-handed craft (i.e. Finn) were physically more demanding than the double-handed ones (i.e. 505) under similar weather conditions (Piehl-Aulin et al., 1977). It was also demonstrated that in double-handed craft, crew members exhibited higher HR responses than their skippers (Piehl-Aulin et al., 1977; Bachemont et al., 1981). For example, in another double-handed boat (470) 15 % of HR readings for the skipper, but 25 % of those for the crew exceed 130 beats min^{-1} while sailing in strong winds (Bachemont et al., 1981). Finally, it was demonstrated that the nature of the activities the skipper and crew performed had significant effects upon the course of the HR. Evidence of this was provided by Piehl-Aulin et al. (1977) who showed that trimming activities of the spinnaker (a high-force upper body activity of the crew) elevated HR by 30 to 40 %.

HR monitoring has provided an approximate estimation of the physical stresses that sailors experience while sailing under different route and weather conditions. However such measurements, taken alone, can be seriously misleading for two reasons: firstly, HR is affected by psychological as well as

physiological factors, and secondly, the physiological implications of a given HR cannot be correctly interpreted until the nature of the muscular effort and its metabolic consequences have been defined. Several additional types of measurement should therefore be made simultaneously before HR data are interpreted.

1.3.2.2 *Gas exchange measurements*

The recent development of a portable telemetric monitor for measuring $\dot{V}O_2$, the Cosmed K2 (Dal Monte et al., 1989) allowed, for the first time, continuous $\dot{V}O_2$ measurements to be carried out under actual sailing conditions. Gallozzi et al. (1993) performed simultaneous $\dot{V}O_2$ and HR recordings in four sailors competing in different boat classes during an international regatta. According to the results of that study, both $\dot{V}O_2$ and HR figures were higher in a single-handed craft (Finn) than in the double-handed ones (Tornado, Star). The values were also higher while sailing upwind than sailing downwind and while performing intense activities such as tacking, or gybing than when sailing free. Although those findings confirmed earlier observations based upon just HR records, a number of factors limited the quantity of information that could be acquired from that study. Such factors were associated with the undemanding wind conditions (4 to 6 ms^{-1}) which prevailed in those tests, the small number of sailors tested, the different classes where measurements were carried out, and

the fact that the $\dot{V}O_2$ values (ranging between 10.4 and 20.5 ml kg⁻¹ min⁻¹) were not presented as percentages of the sailors' measured maximum aerobic powers.

1.3.2.3 *Metabolic measurements*

Piehl-Aulin et al. (1977) carried out blood lactate concentration ([La]) measurements in five single-handed (Finn) and five double-handed (505) sailors who participated in a 40 minute race under strong wind conditions (between 10 and 12 m s⁻¹). The [La] levels recorded in this study ranged between 4 and 8 mM for the Finn sailors and between 2 and 4 mM for the 505 sailors. Such figures confirmed earlier suggestions that single-handed boats were physically more demanding than the double-handed ones and also that, in the case of the Finn sailors, anaerobic metabolism was significantly engaged in those weather conditions. Also the rate of muscle glycogen depletion assessed by biopsies from the quadriceps muscle groups of the Finn sailors indicated that after the 40 minute race muscle glycogen in type I fibres had decreased by 40 % in comparison to the 10 % decrease of muscle glycogen seen in type II fibres.

Stieglitz (1993) monitored the changes of serum potassium (K⁺) metabolism in 27 double-handed (470) sailors coming ashore after the end of a strong-wind regatta. The results of that study indicated that after the regatta K⁺ was lower

than normal by an average of 0.4 mM. Post exercise lowering of blood K^+ is a recognised 'rebound effect', after elevation during the exercise itself. Because it occurs only when exercise has been strenuous, it was suggested that sailing in those wind conditions was highly fatiguing. The results also indicated a highly significant lowering of K^+ as a consequence of increasing wind velocity (extreme instance: 1.2 mM below normal in 14 m s^{-1} wind). Another interesting feature was that the greater the K^+ lowering registered by a sailor, the slower had been his time to complete the final round of the regatta as compared with the times of his competitors.

1.3.3 Studies under simulated sailing conditions

1.3.3.1 Cardiovascular and gas exchange measurements

The most striking feature of the studies involving hiking in the laboratory is the large increase in both systolic and diastolic BP - a characteristic feature of isometric exercise (pp. 6-8). Niinimaa et al. (1977) reported that, during the last minute of a 5-min simulated hiking test, the average systolic and diastolic BP were 198/134 mmHg respectively, whereas the average HR was $137 \text{ beats min}^{-1}$. During another hiking test of the same duration (5 min) Marchetti et al. (1980) recorded substantially lower BP values (160/120 mmHg) but higher average HR responses ($150 \text{ beats min}^{-1}$). Over the same period, Spurway and Burns (1993)

found even lower values (approx. 150/110 mmHg). Such differences in the recorded physiological variables may be principally due to the different postures subjects adopted during hiking, largely attributable to the different boat geometries simulated, and variations of the hiking-specific fitness of the subjects.

Recently Blackburn (1994) showed that the high BP and HR responses seen during simulated hiking were accompanied by modest increments in $\dot{V}O_2$ responses. That study revealed that the recorded values for systolic and diastolic BP (172 ± 13 and 100 ± 14 mmHg, respectively), and for HR (118 ± 25 beats min^{-1}) were disproportionately high in comparison to the $\dot{V}O_2$ which remained at quite low levels (1.12 l min^{-1}).

The fact that the cardiovascular system is challenged relatively more than the oxygen transport system in hiking was initially observed by Harrison et al. (1988) and Spurway and Burns (1993) who both compared the $\text{HR}/\dot{V}O_2$ relationship during a submaximal test on the cycle ergometer on one occasion and during a hiking test on another occasion, in each case using the same subjects for both tests. According to the results of those studies significant differences were found between the intercept (1.37) and slope (0.039) of the mean regression lines for the two trials (Harrison et al., 1988), with the $\text{HR}/\dot{V}O_2$ relationship 1.57 times steeper in hiking than in cycling (Spurway and Burns 1993). Therefore, all the findings described above converged to the same

conclusion: because of the isometric nature of hiking, circulation through the muscles is not adequate, giving rise to modest increments in $\dot{V}O_2$, but substantial increases in BP and HR responses.

Furthermore, the results of a study conducted by Vogiatzis et al. (1993a) indicated that measurements of HR and blood flow velocity (BFV) through the femoral artery continuously increased without achieving a steady state during hiking. This finding supported the view that the failure of the cardiovascular adjustments to meet the demands of the working muscles was the principal cause of fatigue during hiking. This study also demonstrated a slow return of HR and BFV towards resting levels, indicating a pronounced post-exercise hyperaemia which must have borne a close relationship to the restoration of the circulation in the contracting muscles and therefore to the metabolism of those muscles.

1.3.3.2 Metabolic measurements

The two kinds of metabolites traced in blood samples during hiking experiments are blood glucose and [La]. Although the experimental protocols used in those studies were different, the changes in concentration of those metabolites have provided an insight into the metabolic requirements of hiking performance.

The hiking manoeuvre simulated by Niinimaa et al. (1977) induced an appreciable rise of blood glucose (from 87 to 116 mg dl⁻¹). Such a rise was of

course found in the early stages of hiking where blood glucose uptake, mainly by the leg muscles, would have served as one of the major contributors of energy. (Though not remarked by Niinimaa et al. (1977) it seems likely that this early blood-glucose surge was triggered by adrenaline). The short duration of that experiment (5 min) did not extend to following the course of blood glucose during the later stages of hiking where, it was speculated, the reserves of both muscle glycogen and blood glucose would have become depleted (Shephard, 1990). Also, given that blood glucose is essential to cerebral function, it was not surprising that measures of muscular performance were significantly correlated with the sailor's resistance to mental fatigue during sailing competition: a less expected finding of theirs was that initial blood glucose levels were also significantly correlated with sailors' rankings for the ability to sail under light wind conditions ($r = 0.85$), (Niinimaa et al., 1977).

McLoughlin et al. (1993) monitored blood glucose levels in six sailors tested on a hiking simulator after administration of low and high carbohydrate diets. According to their results the low carbohydrate diet induced significantly lower pre-exercise blood glucose levels (4.80 ± 0.19 mM) than a high carbohydrate diet (5.70 ± 0.39 mM). Although blood glucose levels at the end of the 30 min hiking experiment did not change significantly from those at rest in either conditions of diet (5.10 ± 0.26 and 5.80 ± 0.20 mM for the low and high carbohydrate diets respectively), hiking performance was significantly poorer

after the low carbohydrate diet. Those findings led to the suggestion that low muscle glycogen stores, which were brought about by heavy pre-hiking exercise and dietary inadequacies, impaired sailing performance.

There is a lack of agreement between the outcome of [La] measurements which have been made in a limited number of simulated hiking studies. This is probably due to the different experimental protocols used.

Vogiatis et al. (1993a) reported increasing [La] during and after three consecutive hiking efforts carried to the point of exhaustion. The average peak [La] seen 5 min after the end of that hiking test (5.7 ± 1.3 mM) suggested that the contribution of the anaerobic metabolism during hiking was significant. In contrast, lower [La] levels (2.3 ± 0.8 mM) reported from another hiking study challenges the conclusion that anaerobic metabolism plays a significant role during hiking (Blackburn 1994); this study, however, was not continued to exhaustion, and the hiking stance adopted may itself have been less extreme.

1.3.3.3 Electromyographic (EMG) measurements

Examination of muscle activation using electromyography has tended to concentrate on the identification of those muscle groups with the most pronounced activity during hiking. Pichl-Aulin et al. (1977), after measuring the

electrical activity from 10 different muscle groups, concluded that quadriceps (*rectus femoris, vastus lateralis and vastus medialis*) and abdominal (*rectus abdominis and obliquus externus abdominis*) muscle groups exhibited the most pronounced activity during hiking. Those findings were confirmed by Marchetti et al. (1980) who measured the EMG activity from 12 different muscles during hiking. In addition to those muscles with the most pronounced activity reported by Pichl-Aulin et al. (1977), the Italian group reported that *pectoralis major* and *sternocleidomastoideus* were heavily recruited during movements of the upper body associated with sail trimming - but this, of course, is an additional manoeuvre, not to be confused with hiking itself.

Finally, the results of the study conducted by Vogiatzis et al. (1993a) suggested that the hiking posture was sustained by a continuous increase in the muscular activation, as indicated by the continuous increase in the quadriceps EMG recordings. This increase was produced by the recruitment of additional motor units as indicated by the increased amplitude of the EMG activity and further supported by the shift of the myoelectrical signals towards lower frequencies (Fast Fourier Analysis), thus suggesting developing muscle fatigue during hiking.

1.3.4 Fitness training programmes for dinghy sailors

Very little scientific research has been conducted into how best to train to improve hiking performance. The earliest published fitness training study for sailors (Wright et al., 1976) involved an extensive general aerobic base, and such resistance or anaerobic work as was included was far from specific to the hiking muscles. Even then, that study revealed that excess weight and skinfold thickness were reduced, while muscle strength and endurance increased after the 14 weeks training programme. However, this study failed to show whether the programme had been of benefit in improving hiking performance.

The possibility that one training strategy might be better than another was first scientifically investigated in 1982 (Kent, 1983) when 18 sailors were divided into two groups, with half the sailors training isometrically on a hiking simulator, and the other half training to improve leg power with a modified leg weight lift exercise system. At the end of the 7 week training program it was shown that both techniques had improved hiking performance considerably.

A different approach from those attempted before was very recently conducted by Spurway and Burns (1993). The purpose of that study was to determine if a static training regime increased hiking performance more or less than a dynamic one. Mean improvements after the 8 weeks of training did not differ

significantly, however, subjects allocated to the static programme had put less time into it, and said that they found it harder. In terms of benefit per unit time, therefore, the static programme seemed to be more efficient.

Although the previously reported studies gave an indication of the best way to train for hiking strength and endurance, weak control of the amount of training undertaken by each individual during the training programme, and lack of comparison of the results of one training regime with another (Wright et al., 1976) or of the results of the two training groups with a third one ('control group'), reduces the validity of each of the research outcomes. Moreover, improvements in hiking performance of the above described regimes were assessed by the increase of the time taken to volitional exhaustion during hiking (which is subject to psychological influences) and not in terms of significant improvements of the underlying physiological adaptations during hiking.

1.4 AREAS OF NEEDED RESEARCH IN DINGHY SAILING

PHYSIOLOGY

Attempts to simulate the physiological demands of sailing in the laboratory have lacked validation due to subjectively established protocols. In many cases hiking simulations have failed to mimic closely parameters such as: hiking posture, hiking duration, sequence and degree of body movements, and the

physical demands of actual sailing performance. In addition, subjects in many such simulations were not sailors competing in the same boat class as that of the simulator used. Finally, the results have never been compared with findings under actual sailing conditions on the same subjects. Laboratory findings to date should therefore all be treated with a greater or lesser degree of caution.

On the other hand, until recently, the majority of studies conducted under actual dinghy sailing conditions have been limited to measurements of HR trends in an attempt to estimate the physical stresses experienced by sailors while competing (pp. 13-15). Also on-water investigations have lacked standardisation of the testing conditions such as: points of sailing, degree of competition, wind strength and duration of testing and they have been usually conducted on a very limited number of subjects.

In addition, in the existing sailing literature there has never been a study which combined closely related measurements taken during actual and sailing simulated conditions. Therefore, either because of lack of control of testing procedures used in the actual sailing studies (*internal validity*), or because of lack of generalisation and application of the results of the simulated studies to the real world (*external validity*), the research design of most of the sailing investigations has been limited.

Furthermore, although the research outcome from sailing investigations has been indicative of the reasons which limit hiking performance in sailing, there has not been any study to describe the sequence of muscular events taking place when hiking performance cannot be adequately maintained for longer periods of time. Furthermore, there are no studies to show improvements in these muscular responses after the implementation of different training regimes.

1.5 STATEMENT OF RESEARCH PURPOSES

The purposes of the present series of studies were therefore to combine on-water and off-water physiological measurements in order to improve knowledge about the physiological demands of single-handed dinghy sailing. These purposes were achieved by:-

- 1) Investigating the time-course of a number of physiological variables under actual sailing conditions.
- 2) Using this information to closely simulate sailing in the laboratory.
- 3) Investigating in the laboratory a number of physiological variables which could not be studied under real sailing conditions.

More specifically, the following detailed objectives were set in order to approach our aims:-

- To investigate simultaneously the cardiac, respiratory and aerobic demands experienced by national squad-level dinghy sailors during sailing at different wind velocities.
- To investigate the degree to which anaerobic metabolic processes were engaged during sailing at different wind velocities.
- To monitor the sequence and the time spent on different movements performed by the sailors when actually sailing in different wind velocities.
- To simulate sailing in the laboratory in a way that mimicked closely the duration, the quality and the sequence of movements, and the degree to which the cardiorespiratory and metabolic parameters were stressed under actual sailing conditions.
- To study the neuromuscular responses of specific muscles and the links of such responses with stimuli regulating the cardiorespiratory and metabolic changes during simulated sailing.
- To consider reasons which may prevent sailors from maintaining the necessary prolonged hiking posture thus affecting adversely their sailing performance.
- On the basis of the resultant findings to administer sailing-specific fitness training regimes for dinghy sailors which would allow them to hike more comfortably and for longer periods of time.

CHAPTER 2

2. GENERAL METHODS

This chapter outlines the methods, procedures and apparatus used for the measurement of physiological variables. The experimental work was completed in the University of Glasgow exercise physiology laboratory (BASES accredited) and at the Scottish National Sailing Squad's training base, on the Atlantic coast of Scotland (Island of Great Cumbrae). Subsequent chapters outlining procedures for individual studies will make extensive reference to the contents of this chapter.

2.1 SUBJECTS AND TESTING PREPARATION

Subjects were recruited from the single and double-handed Scottish National Sailing Squads and from the Glasgow University Sailing Club. Subjects recruited for study were first informed of the full requirements of participation, and were made aware of the possible hazards and benefits of the exercise testing procedures. Subjects gave informed consent (Appendix 1) to participation in all studies, which had received approval by the local Ethics Committee. Subjects did not exercise unless they were in full health and they were also informed that they could terminate an exercise task at will.

Prior to any study commencing, the subjects' anthropometric characteristics were assessed. Measurements taken included height (barefoot) and body mass (including exercise clothing). When subjects were not familiar with the laboratory testing procedure (i.e. cycling on a bicycle ergometer or hiking on a boat simulator) they were given a pre-test session to practise on the equipment in order to become familiar with the required procedure and establish optimum settings for their individual physique.

2.2 DETERMINATION OF GAS EXCHANGE VARIABLES IN THE LABORATORY

While wearing a nose clip, the subjects breathed through a mouthpiece connected to a low resistance respiratory valve (Hans-Rudolph 2600) attached on the expired-air side to a 1 m length of wide bore tubing. Prior to collections of expired air it was ensured that subjects had several minutes to acclimatise to the respiratory apparatus. Expired gases were collected into evacuated 100 l Douglas bags for a whole number of breaths over a timed period. Immediately after collection fractional concentrations of O₂ and CO₂ from each gas sample were analysed using a paramagnetic O₂ analyser (Servomex 570) and an infrared CO₂ analyser (P.K. Morgan). A calibrated dry gas meter (Parkinson Cowan) was used to measure the volume of expired gas. Gas temperature was measured by a temperature probe at the inlet of the volume meter. Barometric

pressure was determined with a mercury barometer. Expired gas volumes were corrected to standard temperature and pressure, dry (STPD) by the standard formula and the values obtained were used to calculate the mean values of \dot{V}_E , $\dot{V}O_2$ and the ventilatory equivalent for oxygen ($\dot{V}_E/\dot{V}O_2$) over each timed period.

Percentage CO_2 at the mouth was measured by drawing a continuous sample from the mouthpiece through an End-tid IL200 rapid CO_2 analyser. End-tidal values were converted to P_{ET,CO_2} by correcting for water vapour and barometric pressure. A flow head (F1, 100 l) placed on the inspiratory side of the valve allowed breath-by-breath integration of inspired volume by pneumotachography (Computing Spirometer CS7). The pneumotachograph was calibrated with 100 l min^{-1} flow rate. Cumulative inspired volume (V_I) and % CO_2 were recorded throughout on a multichannel recorder. Inspired minute volume (\dot{V}_I) was calculated from cumulative V_I over 15 s periods. All instruments for gas analysis were calibrated before and after each experiment with appropriate standard gas mixtures (BOC) verified with the Scholander technique. Oxygen free N_2 was sampled to calibrate meters to 0 % O_2 and CO_2 , and room air was used to calibrate the O_2 meter to 20.9 %. A gas mixture in the physiological range for O_2 and CO_2 was used to check the linearity of the O_2 meter (16.65 % O_2), and to calibrate the range on the CO_2 meter to 4.04 % CO_2 .

2.3 DETERMINATION OF GAS EXCHANGE VARIABLES AT SEA

The apparatus used to determine gas exchange variables during actual sailing conditions (Appendix 2) was a portable telemetric system, the Cosmed K2 (K2) [Cosmed, Italy; Dal Monte et al., 1989]. The K2 system (Appendix 2) consists of a face mask to sample expired air, a unit to measure ventilation and oxygen concentration in the air, a transmitter and a battery unit, an electrode to pick up heart rate, tubes and cables to connect these components, and a remote receiver unit. Total mass of instrumentation carried by the subjects was about 850 gr. Appendix 2 also shows a subject equipped with the K2 system.

The principle of operation of the K2 system is illustrated in Appendix 2 and is as follows:- Expired air is conveyed through the face mask to a turbine-flow meter of 28 mm diameter. A photo-detector measures the rate of revolutions of the turbine and from this rate the volume flow is calculated. \dot{V}_E at body temperature and pressure, saturated with water vapour (BTPS) is determined at the transmitter. Part of the expired air is sampled by a small tube located near the turbine and fed into the oxygen analyser unit, where the % O₂ concentration of expired air (F_E O₂) is detected by a polarographic oxygen sensor. The $\dot{V}O_2$

at STPD is calculated from \dot{V}_E and $F_E O_2$ by the following formula: $\dot{V}O_2$

$$(\text{STPD}) = \dot{V}_E (F_I O_2 - F_E O_2) (\text{STPD})$$

where $F_I O_2$ is the % O_2 in inspired air, assumed to be 20.9 %.

The \dot{V}_E , $\dot{V}O_2$, $\dot{V}_E/\dot{V}O_2$, and respiration frequency (FR) are calculated and displayed and/or printed by the receiver. These data are also stored in the receiver for later analysis by a personal computer. Intervals of the calculation were set in my experiments at 60 s and data were transmitted to the K2 receiving unit located in a motor-boat (Appendix 2) closely following the test dinghy. The telemetry could cover a distance of about 50 m over water, unless there were obstacles between the transmitter and the receiver. [Makers' instructions claim that 200 m is the operating range inland]. Prior to each test the K2 system was calibrated according to the procedures recommended by the manufacturer (Operator Manual for the K2 system. Vacumetrics Inc./Vacumed Division, Ventura, CA, 4/25/91). The transmitter was turned on for a minimum of 45 min before each test to stabilise the instrumentation. The oxygen analyser was calibrated using room air and a gas with a specific concentration of oxygen (15.9 %) at the beginning of each testing session. The turbine flow meter was calibrated using a 3-l syringe at the beginning of each study. Verification of the reliability of the flow meter and the K2 gas analyser, and the accuracy and reproducibility of the K2 in comparison to the Douglas bag method was carried out prior to the use of K2 and will be reported in detail in Chapter 3.

2.4 DETERMINATION OF CARDIOVASCULAR VARIABLES

Measurements of HR during the laboratory tests were made by means of short range telemetry using a PE 3000 Sports Tester. The electrodes of the Sports Tester monitor were dampened and the belt was fitted around the chest across the xiphoid process. The HR signals were recorded by a micro processor incorporated in the watch and downloaded onto a personal computer to obtain a hard copy of the results (Appendix 3). Sampling frequency was every 15 s.

During the on-water experiments the HR signals were detected as above by a Sports Tester monitor attached to the subject's chest, but were transmitted via K2 and stored in the K2 receiver unit for later analysis. Sampling frequency was set at 15 s.

Blood pressure was measured (in the laboratory only) with the use of a standard clinical sphygmomanometer cuff (Accoson mercury manometer). The cuff of the sphygmomanometer was wrapped snugly around the left arm of each of the subjects just proximal to the elbow. Mean arterial blood pressure (MABP) was calculated as the diastolic pressure plus $1/3$ of the pulse pressure.

2.5 DETERMINATION OF WHOLE BLOOD LACTATE CONCENTRATION

Capillary blood samples were taken from one of the subject's finger tips. The hand was immersed into warm water in order to obtain arterialised blood samples. Prior to sampling, the fingertip was cleaned with a sterile wipe. Then an Autoclix lancet fitted with a new needle was used to make a small puncture in the skin. The first drop of blood was wiped away with tissue and discarded, before 20-25 μ l of arterialised capillary blood was drawn into capillary tubes containing fluoride, heparin and nitrite. The blood samples were then mixed thoroughly for 3 min and analysed in duplicate for whole blood lactate concentration ([La]) using an Analox LM5 lactate analyser. Lactate assay was by an electro-enzymatic method: the maximum rate of oxygen consumption at the O_2 electrode is directly related to [La] according to the equation $L\text{-lactate} + O_2 \text{ ----> Pyruvate} + H_2O_2$. This reaction is catalysed by the enzyme L-lactate: oxygen oxidoreductase (LOD). The mean value of the two determinations was considered as [La]. Prior to blood analyses the analyser was calibrated with 5 and 8 mM sodium lactate standards provided by the manufacturer, and it was checked with the standards at regular intervals.

Verification of the reproducibility of the Analox LM5 lactate analyser was established by introducing to the analyser sodium lactate solutions of known

concentration (1, 2, 2.5, 4, 5 and 8 mM) on five different occasions. The calculated coefficients of variation (ranged between 3.9 and 6.1%) revealed that performance of the lactate analyser was satisfactory reproducible.

2.6 DETERMINATION OF ELECTROMYOGRAPHIC ACTIVITY

An Electromyographic (EMG) unit (custom build in Glasgow University-IBLS-Electronics unit) was employed to record the electrical activity developed in different muscle groups. The EMG apparatus provided simultaneous resolution of 4 separate surface EMG signals and each channel comprised the following basic elements (Appendix 4):

- a) Differential pre-amplifier with fixed gain of 60 dB and a bandwidth of 4 Hz to 10 KHz. In order to reduce the physical size of the pre-amplifier (particularly important since several were to be used on one subject) surface mount technology was employed.
- b) Isolation amplifier of unity gain and a bandwidth of DC to > 10 KHz.
- c) A passive distribution unit incorporated between each pre-amplifier in use and the corresponding isolation amplifier reduced the number of cables between the subject and the signal processing system. The distribution unit routed power to all 4 pre-amplifiers and in turn connected the 4 signal outputs to the isolation amplifier.

- d) The power supply for the pre-amplifier and its low impedance output, which were connected to the system via a miniature ribbon cable and IDC connector.
- e) A filter/amplifier module which comprised a 50 Hz notch filter, a band-pass filter and a variable gain amplifier. The output of this amplifier represented the raw EMG output signal.
- f) A rectifier/integrator allowing full-wave rectification and integration of the raw EMG signal. The integrator time constant was fixed at 100 ms thus allowing a realistic representation of the level of EMG activity to be displayed. The output of the integrator constituted the main EMG activity level output.
- g) An analogue multiplexer, which provided a method of simultaneously monitoring the output from all 4 channels for both the raw and integrated EMG signals via a computer.

A BBC Master computer was configured to provide a digital channel selection command output to the multiplexer while accepting in return the corresponding analogue signal into an A-D converter.

The EMG activity was picked up by pairs of skin electrodes with contact areas of 0.65 cm^2 , placed 15 mm apart in a line parallel to the muscle axis. After the skin was carefully prepared for their placement, the electrodes were filled with commercial electrode jelly and secured on the skin with adhesive tape. Interelectrode resistances of between 5 and 10 $\text{K}\Omega$ were considered acceptable for recording purposes. When experiments were performed on a stationary

sailing simulator (Chapter 5), the multiplexed output from the multi-channel EMG unit was handled by a computer program run by a BBC Master computer. This program was designed to integrate and display the rectified EMG signals, observed from the 4 channels, over a period of 4 s. A mathematical calculation of the integrated EMG signal was performed by the program and the integrated EMG (IEMG) activity was expressed as a value representing the area that the integrated signal occupied. A printed hard copy provided graphical and tabular information of the IEMG activity recorded from all 4 channels (Appendix 4). An alternative way of sampling continuously the IEMG activity was to direct the integrated output from the multi-channel unit to a chart recorder where the area which the integrated activity occupied was determined manually over each recorded period. This sampling method was used when experiments were performed on a non stationary sailing simulator (Chapter 4).

Calibration of the computer system was performed by applying a range of signals of constant and known amplitude from a DC level Millivolt Calibrator. Specifically calibration was aimed at verifying and validating the computer procedure used to determine the area that the integrated EMG activity occupied. Square waves of known voltage from the calibrator were introduced into the system and the area under them was compared with the value provided by the EMG programme.

2.7 DETERMINATION OF FORCES

A load indicator, which was a general purpose tensiometer, was used to measure and control the force which was continuously exerted by the subjects on the toe-straps of the sailing simulators. The load indicator comprised two basic elements:

- a) The load cell transducer unit (Radio Spares): Maximum load capability 100 Kg.
- b) The digital display unit (custom build in Glasgow University-IBLS-Electronics unit).

The digital display unit was connected to the transducer and displayed the force in Kg. A chart recorder was connected to the output of the digital display unit and used to produce a hard copy of the exerted force.

Verification of the reproducibility and accuracy of the load cell was carried by applying to the system a number of weights of known mass (5, 10, 15, 20 and 30 Kg) in two different occasions. The calculated coefficients of correlation (ranged between 0.94 and 0.99) revealed that the load cell was satisfactory reproducible and accurate.

2.8 DETERMINATION OF ANGULAR DISPLACEMENT OF HIP AND KNEE JOINTS

Two twin axis strain electrogoniometers (Penny and Giles - M 110 series: Blackwood Limited) were used to measure, and hence ensure control of the angular displacement at hip and knee joints of the subjects (Appendix 5).

The electrogoniometers were connected to a BBC Master computer via two conditioning units. A computer program (custom written in Glasgow University-IBLS-Electronics unit), was designed to handle the output from the transducers and recorded and displayed the angular displacement of the hip and knee joints against the time that the exercise lasted. A value representing the mean angular displacement at each joint was also calculated by the program. A printed hard copy provided graphical and tabular information (Appendix 5).

The computer program provided a semi-automatic calibration procedure according to which the electrogoniometers were calibrated prior to each testing session. Calibration involved manual setting of the end blocks of the electrogoniometers at minimum and maximum angular positions.

CHAPTER 3

3. STUDIES UNDER ACTUAL SAILING CONDITIONS

3.1 INTRODUCTION

Research in dinghy sailing has a very short history that goes back to the end of 1980's (Piehl-Aulin et al., 1977), and it seems fair to state that until recent years its development has lagged behind the scientific study of other sports such as running and cycling. This was largely due to the difficulties arising from the environmental conditions which made scientific study almost impossible to conduct. Hence the majority of information gathered from sailing studies under actual conditions has been limited to HR measurements. HR recordings, carried out by the use of short range telemetric devices, have provided an approximate estimation of the physical stress sailors experience during actual sailing conditions (Piehl-Aulin et al., 1977; Marchetti et al., 1980; Pudenz et al., 1981; Bachemont et al., 1981; Harrison and Coleman 1987). However, HR measurements, considered in isolation, can be misleading. One reason is that sailing, especially on the open sea or in a competition itself represent extra psychological stresses leading to an elevated HR. Also, the HR response to purely-physical exercise varies considerably with the kind of exercise. Therefore the physical implications of a given HR can only be

correctly interpreted if additional kinds of measurements, less likely to be affected by psychological factors and giving complementary physical information, are simultaneously performed. Such measurements should be principally aimed at the most direct possible assessment of the energy expenditure (EE) during sailing under different weather conditions, on different points of sailing and in different levels of competition. EE measurements would promote the functional classification of the sport of dinghy sailing and would also ascertain which physiological functions need to be improved for maximising sailing performance.

Measuring $\dot{V}O_2$ has been a key component in researching the EE of a large number of activities (Durnin and Passmore 1967). For activities that are not performed in the laboratory, expired air is usually collected in Douglas bags (DB) and transported to the laboratory for analysis. However, the limitations to the subjects' movements imposed by carrying bulky apparatus such as a DB, in association with the brief time during which collection of expired air could be carried out, discouraged researchers from conducting $\dot{V}O_2$ measurements in the field.

In dinghy sailing there has been just a single attempt (Marchetti et al., 1980) to measure $\dot{V}O_2$ with the use of the DB method. The low $\dot{V}O_2$ figures recorded in that study ($5.5 \text{ ml kg}^{-1} \text{ min}^{-1}$) were presumably due to the fact that expired air

from sailors was collected into Douglas bags for a brief period of 30 seconds of actual sailing, followed by a longer period of 4.5 minutes during which time the subjects were sitting motionless without sailing.

Attempts to reduce the size of the monitoring apparatus (Riley 1972; Ballal and MacDonald 1982) had the drawback of poor reliability and problems associated with the weight and the size of the apparatus. Relatively recently, a new miniaturised portable telemetric device for measuring $\dot{V}O_2$, the Cosmed K2 (K2) (Dal Monte et al., 1989) was developed. Comparison of measurements obtained by the K2 system with those obtained on the same subjects with other equipment, well known for its reliability, has however led to controversy with regard to the accuracy of the K2 system. Dal Monte et al. (1989) and Kawakami et al. (1992) found no differences between the $\dot{V}O_2$ values obtained by the K2 system and either an on line gas exchange system or the DB method. On the other hand, Peel and Utsey (1993) and Lothian et al. (1993) reported that the K2 system read consistently lower $\dot{V}O_2$ values when it was compared to either a metabolic cart or an on line gas exchange system. The above authors concluded that the lower $\dot{V}O_2$ values obtained by the K2 system were due to the method of collecting and analysing the expired air, rather than the method of calculating $\dot{V}O_2$. Despite this controversy, the K2 system has been widely used to evaluate the EE of a number of sport activities such as cycling, running,

kayaking (Faina et al., 1989), rowing (Kawakami et al., 1992), and volleyball (Concu et al., 1992).

Gallozzi et al. (1993) were the first to use the K2 system during actual sailing and attempt to measure $\dot{V}O_2$ for long periods of time. Although their attempt was in itself successful, it was concluded that the results could not be considered of great value because of the undemanding wind conditions prevailing during those tests (4-6 ms^{-1}), the small number of subjects (4 sailors) and the absence of data enabling the sailors' $\dot{V}O_2$ responses to be expressed as percentages of their maximum aerobic powers.

The present chapter reports the results of a series of studies designed to investigate the following aspects:

- The accuracy, validity and the reproducibility of the K2 system.
- The feasibility of the application of the K2 system in on-water studies.
- The aerobic demands of dinghy sailing as assessed using the K2 system.

Studies performed were as follows:

Study I tested the reliability of the two major functions of the K2 system (measurements of volume-flow and analysis of oxygen concentration). The accuracy of $\dot{V}O_2$ measurements performed by the K2 was also investigated by comparing it with the DB method during a laboratory test performed on a cycle

ergometer to the point of exhaustion. (The maximum $\dot{V}O_2$ and HR values recorded from subjects during that test were later used to calculate the percentages of maximum $\dot{V}O_2$ and HR required in dinghy sailing). The reproducibility of $\dot{V}O_2$ measurements carried out by the K2 system was finally defined by monitoring a single subject who exercised on a treadmill on 10 different occasions.

In study II, the use of the K2 system allowed a preliminary investigation into a number of cardiorespiratory parameters during sailing around a race-type course under different weather conditions, on different points of sailing, and under different levels of competition. In addition, the possibility of using HR recordings for the prediction of $\dot{V}O_2$ was thoroughly investigated.

In study III, the use of the K2 system allowed the investigation of the fractional utilisation of maximum oxygen uptake (% $\dot{V}O_2$ max) and the percentage of maximum HR (% HR max) required to sail a single-handed dinghy under different wind velocity conditions. In addition, [La] levels were determined.

3.2 METHODS

3.2.1 Subjects

Eight male Laser sailors (members of the Scottish National single-handed Sailing Squad and the Glasgow University Sailing Club) volunteered to participate in studies I and III. Their mean (\pm SD) age, height and body mass were 23 ± 5 yrs, 178 ± 8 cm and 74 ± 14 kg, respectively. The age, height and body mass of the male runner who exercised on the treadmill during study I were 35 yrs, 185 cm and 82 kg, respectively. Subjects in study II were six sailors (five males and one female - members of the Scottish National single-handed Sailing Squad). Their mean (\pm SD) age, height and body mass were 23 ± 6 yrs, 180 ± 8 cm and 77.5 ± 13 kg, respectively.

3.2.2 Study I: Accuracy, Validity and Reproducibility of the K2 System

3.2.2.1 Accuracy of measurements

Volume-flow. The accuracy of the volume-flow measurements of the K2 turbine was examined twice by connecting a syringe (Best, Nr. 464300 Handichpump, Erich Aeger, Germany) to the K2 turbine flow meter. Four known quantities of air corresponding to flows of 20, 40, 60 and 120 l min^{-1} ,

were pumped into the flow meter by moving the syringe lever back and forth once every 6 s, 3 s, 2 s, and 1 s respectively. The K2 system was set up to analyse flow at 60 s intervals. To examine the reproducibility, measurements were obtained in duplicate for each flow rate. The error of measurements was calculated using the following equation:

$$\text{Error (\%)} = (\text{measured volume} - \text{actual volume}) * 100 / \text{actual volume}.$$

Oxygen concentration. Two mixtures of gases with specific concentrations of oxygen (15.9 % and 16.6 %) were introduced on two different occasions to the sampling tube of the K2 system by manually operating the K2 sampling pump. Before the introduction of the gases, the oxygen concentration registered by the K2 system was 20.9 %. The error of measurements was calculated using the following equation:

$$\text{Error (\%)} = (\text{measured oxygen concentration} - \text{actual oxygen concentration}) * 100 / \text{actual oxygen concentration}.$$

3.2.2.2 Validity of $\dot{V}O_2$ measurements performed by the K2 System -

Assessment of the sailors' maximum aerobic powers

The validity of the $\dot{V}O_2$ measurements performed by the K2 system was examined by comparing it with the DB method during an ergometric test in the laboratory. Each subject performed an incremental exercise test on a cycle

ergometer (Monark 818) to the point of exhaustion. The pedal frequency was 60 rpm and the load was increased by 0.5 Kp per minute (30 Watts per minute) from an initial load of 0.5 Kp (30 Watts). Expired gases were collected each minute by both the K2 and the DB methods. This was achieved by attaching a low resistance respiratory valve (Hans-Rudolph 2600) to the outlet of the K2 turbine flow-meter such that all the expired air from the subjects was sampled by the K2 turbine system before being collected in successive Douglas bags. HR was also broadcast every minute by means of telemetry (K2). The expired gas samples contained in Douglas bags were analysed using oxygen and carbon dioxide analysers and their volume was measured by means of a dry gas meter. The highest $\dot{V}O_2$ and HR values obtained during each subject's test were normally used as his $\dot{V}O_2$ max and HR max values respectively. Additional criteria for accepting the $\dot{V}O_2$ as maximal were an observed levelling off or slight decrease in $\dot{V}O_2$ with increasing work load, HR reaching the predicted maximal value for the age group, and respiratory exchange ratio greater than unity. Ambient temperature and relative humidity during the tests ranged from 18 to 22° C and 25 to 35 %, respectively.

3.2.2.3 Reproducibility of $\dot{V}O_2$ measurements performed by the K2 System

Verification of the reproducibility of $\dot{V}O_2$ measurements performed by the K2 system was carried out during submaximal exercise on a motor-driven treadmill (Quinton) performed by a single subject on 10 different days. The subject accomplished 5 work rates, walking or running for 3 min at the following speeds: 2 mph, 3 mph, 4.5 mph (4 mph proved biomechanically uncomfortable for the subject), 5 mph and 5.5 mph. The treadmill remained horizontal for the 4 initial stages and was then elevated to 3 % during the last stage. Gas collection was performed during the last minute of each of the 3 minute periods using the method described in the previous section. Steady state conditions during gas sampling processes were ensured by HR recordings via electrodes attached to the chest of the subject. Analyses of expired gases were performed using the apparatus described earlier. Ambient temperature and relative humidity during the tests ranged from 19 to 21° C and 20 to 30 %, respectively.

3.2.3 Study II: On-water measurements of cardiorespiratory parameters

On-water measurements were performed during simulated racing conditions on 8 different days. Wind velocity, ambient temperature, relative humidity and barometric pressure during the testing days ranged between 4 and 14 m s⁻¹ (6-20 knots), 4° and 10 ° C, 20 and 30 %, and 750 and 765 mmHg, respectively.

During the tests, the K2 was strapped to each subject's chest with the tubes from the face-mask positioned under the rubber neck seal of his protective clothing (which in every case was a 'dry-suit'). $\dot{V}O_2$, $\dot{V}E$, respiratory frequency (FR), tidal volume (TV) and HR responses were recorded telemetrically every minute and transmitted to the K2 receiving unit located in a motor-boat following closely behind at a distance (approx. 50 m) found necessary to avoid interference with transmission by wave-motion. The wind velocity was frequently recorded from the motor-boat using a portable anemometer. Information relative to the subjects' activities (point of sailing - frequency of tacking - trimming actions of the sail) were also continuously recorded using a portable audio tape recorder.

During each simulated racing experiment subjects accomplished several upwind and downwind legs, sailing around a trapezium-shaped course. Nine overall tests were performed on the six subjects. Four of the on-water tests in this study were performed while the subjects sailed without competition, two while subjects participated in a boat to boat competition (match race) and in the remaining three tests subjects were competing in a fleet of boats.

3.2.4 Study III: Aerobic and anaerobic demands of dinghy sailing at different wind velocities

In this study subjects underwent a 10 minute continuous upwind sailing test, during which they steered and balanced their boats while keeping the wind continuously on the same side (i.e. without tacking). The recorded cardiorespiratory responses and the method of data acquisition using the K2 system in this study were identical to those described earlier for study II. In addition to the cardiorespiratory recordings, finger tip capillary blood samples were taken from each subject one minute before and three minutes after the end of each test and analysed in duplicate for [La]. Blood samples were collected in capillary tubes and stored in an ice bath before they were analysed.

Due to the extreme difficulty in standardising the environmental conditions for each subject's on-water test, all physiological parameters measured were subsequently related to the wind velocity which prevailed during that particular test. The wind velocity was frequently recorded from the motor-boat using a portable anemometer.

During the on-water testing, wind velocity ranged between 4 and 12 m.s⁻¹ (6-18 knots), ambient air temperature between 4° and 12° C, relative humidity between 20 and 30 % and barometric pressure between 745 and 761 mmHg.

3.2.5 Statistical analyses

Study I: To test the accuracy of the K2 system the $\dot{V}O_2$ measurements obtained by the K2 and DB methods were compared using the paired Student's t-test. Coefficient of variation was calculated to check the reproducibility of $\dot{V}O_2$ measurements recorded from the subject while exercising on the treadmill.

Study II: One-way ANOVA, followed by Newman-Keuls follow-up test where appropriate, was used to determine if changes in the recorded physiological variables were significant.

Study III: Subjects were divided into groups of four on the basis of the average wind velocity conditions (moderate or strong) during their tests. Differences between means were estimated using t-tests for independent samples. Interactions between pre and post-sailing values and wind conditions were examined by a two-way ANOVA. This test was followed by a t-test for paired or independent samples as appropriate.

For all statistical procedures Pearson's product moment correlation coefficient was applied to express correlations between variables and statistical significance was accepted at $P < 0.05$. All data are presented as means \pm (SD).

3.3 RESULTS

3.3.1 Study I: Accuracy, Validity and Reproducibility of the K2 System

3.3.1.1 Accuracy of measurements

The measurements of volume-flow showed that the values obtained by the K2 system were in very good agreement with the actual volumes introduced by the syringe. The measurement errors ranged between - 3.1 % and 0.25 %. Also duplicate measurements for each flow rate demonstrated a good relationship (correlation coefficient = 0.99) between the first and the second measurements.

The figures obtained from the K2 for the oxygen concentration of the standard gases containing 15.9 % and 16.6 % of oxygen (evaluated and analysed as described in Chapter 2) were 15.9 and 16.6 % respectively. The calculated error for both gases was therefore zero. Also duplicate measurements were perfectly reproducible with a correlation coefficient (r) of 1.00 between the first and the second measurements.

*3.3.1.2 Validity of $\dot{V}O_2$ measurements performed by K2 System -
Assessment of the sailors' maximum aerobic powers*

The duration of cycle exercise to exhaustion for the subjects ranged between 10 and 12 minutes. Since only three subjects completed more than 10 minutes, K2 and DB measurements up to the 10th minute were used in the analysis. $\dot{V}O_2$ max values obtained by the two methods were analysed separately. There were no significant differences in absolute $\dot{V}O_2$ measurements obtained by the K2 and the DB methods (Figure 1). In addition no significant difference was observed in $\dot{V}O_2$ max between the two methods.

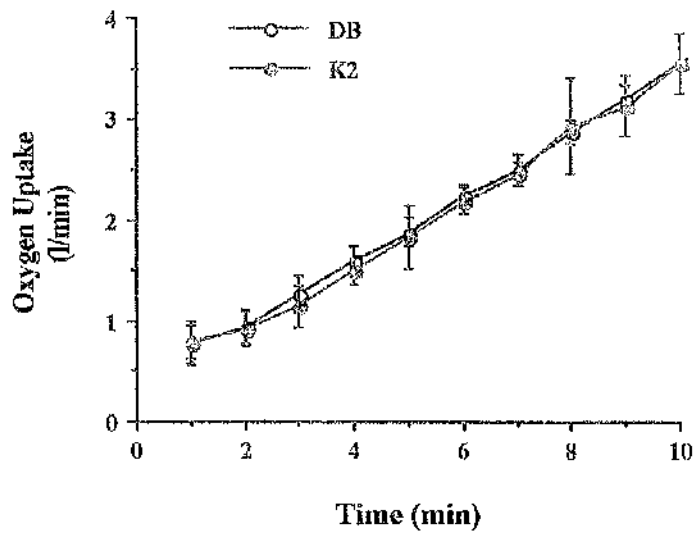

Fig. 1. Oxygen uptake values recorded simultaneously using the K2 and Douglas bag methods, for eight subjects exercising on a cycle ergometer with one minute work load increments.

3.3.1.3 Reproducibility of $\dot{V}O_2$ measurements performed by the K2 System

Table 1 shows the coefficients of variation for the $\dot{V}O_2$ measurements performed by both the K2 and DB methods for each of the five work rates. Although the coefficients of variation were larger for the K2 than the DB method, no significant differences between those values were observed. The greatest variation between the 10 trials was observed for both methods at the last work rate.

3.3.2 Study II: On-water measurements of cardiorespiratory parameters

Table 2 shows the average $\dot{V}O_2$ and HR responses recorded from the 9 on-water experiments which were carried out on the 6 subjects. The average $\dot{V}O_2$ and HR values for all experiments were 21.3 ± 3.5 ml kg⁻¹ min⁻¹ and 146 ± 12 beats min⁻¹, respectively. The measured variables were always greater in magnitude when sailing upwind than while sailing downwind. When the duration and wind velocity of upwind and downwind legs were identical, the differences in the recorded physiological responses between those legs were significant (Figure 2).

Stages	K2 coefficient of variation	DB coefficient of variation
1	3.27 %	2.80 %
2	3.96 %	2.87 %
3	5.07 %	3.89 %
4	6.40 %	4.52 %
5	7.18 %	5.37 %

Table 1: Coefficients of variation for $\dot{V}O_2$ measurements performed by K2 and DB methods for each of the five work stages.

Subjects	Sailing time (min)	Wind speed (m s ⁻¹)	$\dot{V}O_2$ (ml kg ⁻¹ min ⁻¹)	HR (beats min ⁻¹)
1a	55	13.0	23.80 ± 4.0	145 ± 9
1b	42	10.0	19.62 ± 2.3	135 ± 8
2	29	14.0	23.57 ± 3.3	175 ± 10
3a	38	8.5	20.63 ± 3.8	143 ± 18
3b	40	9.0	19.54 ± 4.0	145 ± 19
3c	28	10.0	25.74 ± 5.2	176 ± 12
4	20	8.5	19.93 ± 4.5	138 ± 12
5	56	4.5	16.44 ± 5.2	120 ± 17
6	28	11.5	22.80 ± 1.6	140 ± 7

Table 2: Average $\dot{V}O_2$ and HR figures derived from the nine on-water measurements on the six subjects. The duration of each individual measurement, and the average wind velocity over this time, are also indicated. Letters a, b, c, indicate separate measurement-sets from the same (numbered) subject.

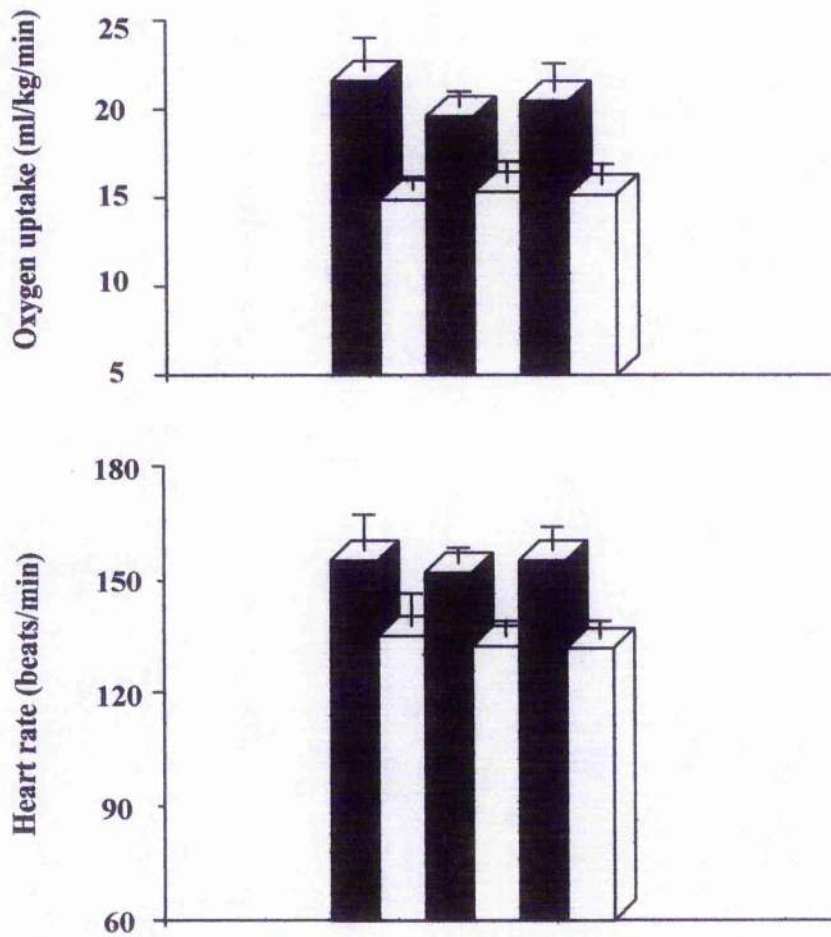

Fig. 2. The average $\dot{V}O_2$ and HR responses in a typical individual during alternate periods of sailing upwind (filled columns) and downwind. Note that the duration of both upwind and downwind legs were identical (7 min) in this example.

$\dot{V}O_2$ and HR values for all experiments were significantly correlated to the average wind velocity ($r = 0.76$ and 0.64 , respectively) prevailing during the on-water tests.

The average $\dot{V}O_2$ and HR responses were significantly different between three legs on the same point of sailing, equal in duration but different in competitive level. The three legs under comparison were performed by a single subject under identical wind velocity conditions while sailing without competition, while competing against a single boat, and while racing in a fleet of boats (Figure 3). Racing in a fleet of boats elevated the physiological responses significantly more than sailing free or competing against a single boat.

Significant correlations between $\dot{V}O_2$ and \dot{V}_E responses for each subject were found from the nine on-water measurements. The correlation coefficients ranged between 0.76 and 0.88 . Also eight out of the nine observed relationships between $\dot{V}O_2$ and HR responses were significant. The correlation coefficients ranged between 0.52 and 0.81 (Figure 4).

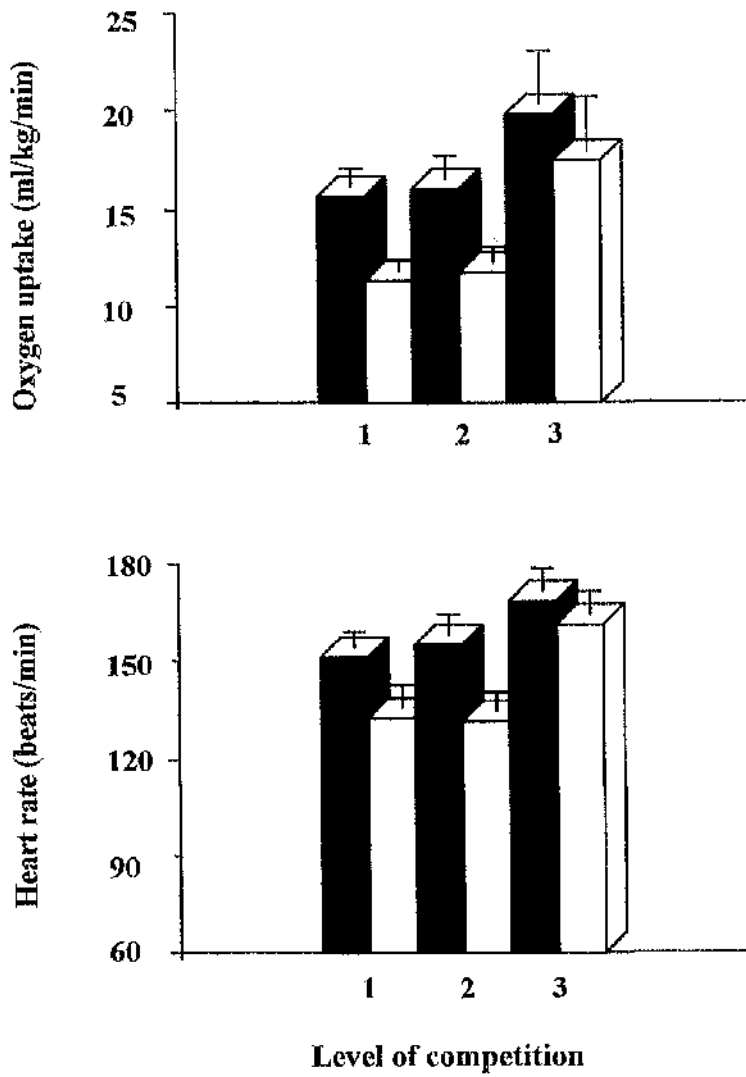

Fig. 3. $\dot{V}O_2$ and HR responses in a representative individual during both upwind (filled columns) and downwind legs while (1) sailing without competition, (2) racing against a single boat and (3) racing in a fleet of boats.

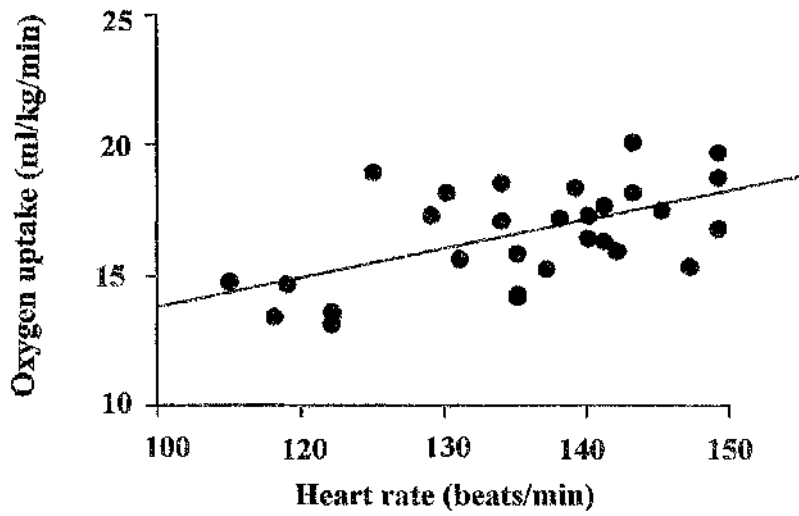

Fig. 4. Minute-by-minute relationship ($r = 0.79$, $P < 0.05$) between $\dot{V}O_2$ and HR responses in a typical individual while sailing for 29 minutes.

3.3.3 Study III: Aerobic and anaerobic demands of dinghy sailing at different wind velocities

For each subject the average $\dot{V}O_2$ and HR responses during each sailing test were expressed as percentages of the maximum values obtained during the laboratory ergometric tests (Study I). The average $\dot{V}O_2$ max and HR max values obtained from all the subjects were $52 \pm 6 \text{ ml kg}^{-1} \text{ min}^{-1}$ and $196 \pm 6 \text{ beats min}^{-1}$ respectively. Those $\dot{V}O_2$ max values were within the range of values (Figure 5) reported in previous sailing studies (Niinimaa et al., 1977; Piehl-Aulin et al., 1977; Thomas 1981; Blackburn 1994).

For all 8 subjects the average absolute values of $\dot{V}O_2$ and HR, percentages of respective maximum values, and post-test [La] are presented in Table 3. Also Table 3 presents the average absolute and percentages of $\dot{V}O_2$ max and HR max values and the average post-test [La] values when subjects were divided into 2 groups of 4 on the basis of the wind velocity (moderate or strong) prevailing during their tests. The average $\dot{V}_E/\dot{V}O_2$ and oxygen pulse are also presented in Table 3.

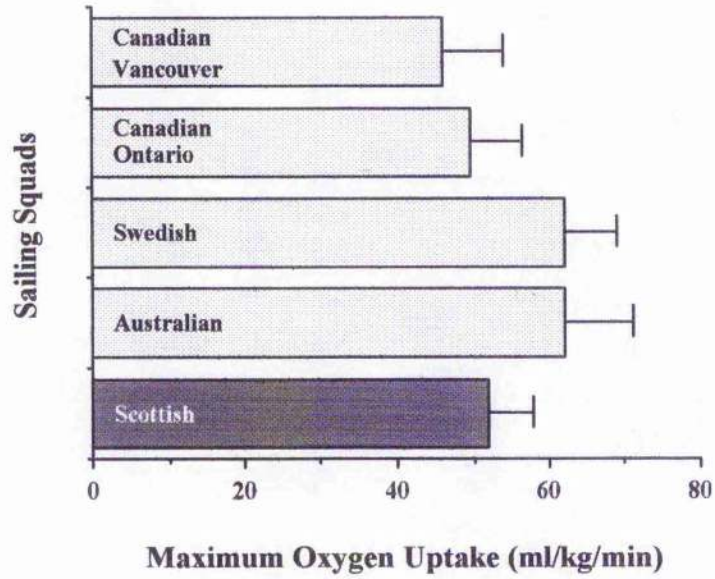

Fig. 5. The average maximum oxygen uptake values of high performance sailors reported by Niinimaa et al. (1977); Piehl-Aulin et al. (1977); Thomas (1981) and Blackburn (1994) in comparison to that measured from the Scottish sailors.

Wind speed (m s ⁻¹)	n	$\dot{V}O_2$ (ml kg ⁻¹ min ⁻¹)	Percent of $\dot{V}O_2$ max	HR (beats min ⁻¹)	Percent of HR max	$\dot{V}_E/\dot{V}O_2$	Oxygen Pulse (ml beat ⁻¹)	[La] (mM)
4 - 8	4	19.0 ± 2.0	37.0 ± 8.0	135 ± 11	69 ± 10	24.2 ± 1.4	9.5 ± 0.8	1.6 ± 0.2
8 - 12	4	22.0 ± 3.0	42.0 ± 4.0	155 ± 21	79 ± 10	29.4 ± 2.0	10.5 ± 0.4	3.0 ± 0.6
4 - 12	8	20.5 ± 2.5	39.5 ± 6.0	145 ± 16	74 ± 10	26.8 ± 1.6	11.0 ± 0.7	2.3 ± 0.4

Table 3: Average absolute values of $\dot{V}O_2$ and HR, percentages of respective maximum values, $\dot{V}_E/\dot{V}O_2$, oxygen pulse and post-test [La], values for all 8 subjects and for each group of 4 subjects when they were divided on the basis of the wind velocity prevailing during their tests.

Comparison of the physiological responses recorded from the 4 subjects who sailed in moderate winds with those recorded from the subjects who sailed in strong winds showed that $\dot{V}O_2$, HR and post test [La] were significantly higher in the strong winds.

Finally, the percentages of $\dot{V}O_2$ max and HR max, and the post-test [La] values were significantly correlated to the wind velocity prevailing during each subject's test ($r = 0.73, 0.87$ and 0.88 , respectively - Figures 6, 7).

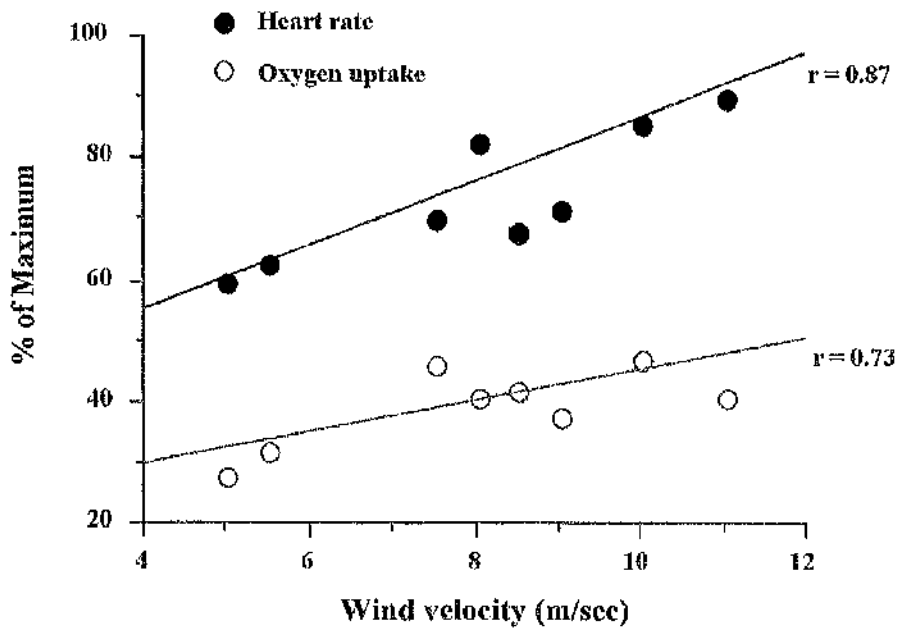

Fig. 6. Relationship of the percentage of maximum oxygen uptake and heart rate of each subject in an on-water test to the average wind velocity for that test.

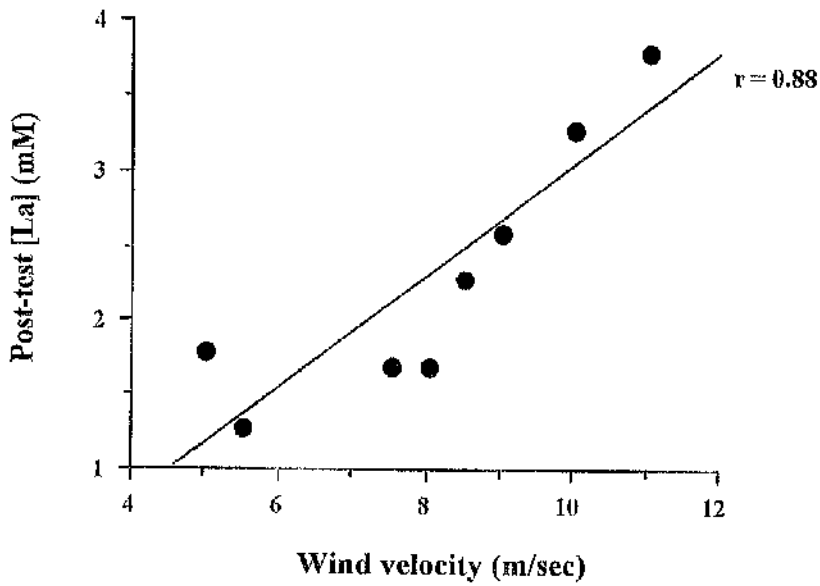

Fig. 7. Relationship between each subject's post-test [La] and the average wind velocity for that particular test. [Note: There is an obvious temptation to treat this Figure in the same terms as an incremental lactate test in dynamic exercises, suggesting in this instance a "lactate threshold" at wind velocity 7.5 to 8.0 m/sec. The reason why such an analysis has not been performed in the present study is that each of the above points has been obtained from a different sailor].

3.4 DISCUSSION OF CHAPTER 3

3.4.1 Accuracy, Validity and Reproducibility of the K2 System (Study I)

The results of this investigation indicated that functioning of the K2 system was highly reliable (Vogiatzis et al., 1993b; 1994). The K2 flow meter and the oxygen concentration sensor read accurately the flow volumes and standard gases respectively introduced to the K2 system. The error of measurement for both functions was smaller than $\pm 5\%$ indicating a good relationship between the K2 and the validation instruments.

The accuracy of the $\dot{V}O_2$ measurements carried out by the K2 system was demonstrated by comparing it with the DB method. The results revealed no differences in the $\dot{V}O_2$ measurements between K2 and DB methods (Vogiatzis et al., 1995a). This finding is in agreement with that of Dal Monte et al. (1989) and Kawakami et al. (1992), but conflicts with the findings of Peel and Utsey (1993) and Lothian et al. (1993). Discrepancies concerning the reported validity of the K2 system could possibly be associated with any of at least three features: (i) the method used to check the accuracy of the K2 system, (ii) the accuracy of the system with which the K2 function was compared or (iii) differences between the ways in which the respective systems calculated $\dot{V}O_2$. Under heading (i), we may note that Peel and Utsey (1993) and Lothian et al.

(1993) both carried out measurements of $\dot{V}O_2$ when subjects exercised with one recording system followed by the other in a randomised order. They then compared the data obtained by the two systems on the same subjects and concluded that $\dot{V}O_2$ readings were significantly different at some stages of the exercise protocol without therefore taking into consideration the day to day variability in each subject's performance. In the present study such a source of error was eliminated by collecting expired gases simultaneously with both recording systems.

An alternative reason of type (i) which might account for the discrepancy of findings between the present investigation and those of Peel and Utsey (1993) and Lothian et al. (1993), is the different type of exercise used in the latter studies. The testing protocols of those studies involved running on a treadmill which might possibly have caused interference to the electronic components of the K2 recording system as compared to cycling on a stationary cycle ergometer as in the present study.

Under heading (ii), it should not be overlooked that in the studies of Peel and Utsey (1993) and Lothian et al. (1993) the recording apparatus used to examine the validity of the K2 system was an on-line gas exchange system, the validity of which had not been specified. In the present investigation, the K2 system was compared to the DB method which has long been considered to be the most accurate method of measuring $\dot{V}O_2$.

Finally under heading (iii), Peel and Utsey (1993) correctly pointed out that the K2 system has to assume values for respiratory exchange ratios, since it does not measure $\dot{V}CO_2$. However, they checked whether this factor explained the differences between the K2 and on-line readings, and found that it did not.

With regard to the reproducibility of $\dot{V}O_2$ measurements obtained by the K2 system it can be concluded that the reproducibility of this system is comparable to that of the DB method. More specifically under no circumstances did the coefficients of variation between the K2 and the DB method differ by more than 2 %. Also the K2 coefficients of variation never exceeded 7.5 % and this small variation is particularly significant when taking into consideration the fact that the 10 trials on the same subject were conducted over a period of one month during which time the subject might also have varied in his physical condition.

It was concluded that the K2 telemetric system is a reliable, accurate and reproducible device for measuring $\dot{V}O_2$, comparable to the DB method for the range of measured values.

3.4.2 On-water measurements of cardiorespiratory parameters (Study II)

The main objective of this study was to test the feasibility of application of the K2 system during actual sailing in various weather conditions and on different

points of sailing. An additional objective was to determine if the relationship between $\dot{V}O_2$ and HR figures recorded from subjects during actual sailing was linear and therefore to examine if $\dot{V}O_2$ could be accurately predicted from HR recordings.

During the on-water experiments the K2 device did not cause any personal discomfort nor did it present any restriction to the sailors' mobility. The components of the K2 system were found to be safely protected under the sailors' waterproof clothing and the K2 system happily remained dry even during capsizes! The telemetry also proved to be effective when following the boats relatively closely, yet without interfering with the race tactics of the sailors. The battery life of the K2 unit was long enough to allow continuous measurements for up to one hour.

All cardiorespiratory parameters studied were elevated by sailing upwind (Vogiatzis et al., 1993b; 1994). When the duration and the wind velocity of upwind legs were identical to that during downwind legs, both $\dot{V}O_2$ and HR responses during the upwind legs were significantly higher in comparison to those during downwind legs. Such findings confirm the results of other investigators who, while carrying out just HR measurements, found that sailing upwind was physically more demanding than sailing downwind (Piehl-Aulin et al., 1977; Pudenz et al., 1981; Bachemont et al., 1981). Also the findings of

this study are in agreement with those of Gallozzi et al. (1993) who reported that $\dot{V}O_2$ and HR responses were always elevated by sailing upwind.

The level of competition seemed also to influence significantly the recorded physiological responses. Presumably, when racing in a fleet of boats, the presence of a larger number of competitors resulted in greater psychological stress and level of arousal than that experienced while sailing without competition or while racing against a single boat. However, the psychological mechanisms alone would be expected to raise only HR, not $\dot{V}O_2$. Increased *activity*, prompted by the arousal, must be proposed if this factor is to be considered relevant to the present data.

$\dot{V}O_2$ and HR responses were significantly correlated to the wind velocity which prevailed during each subject's test. However, because of the different competitive conditions under which the readings were made, such relationships will be re-examined in the following section.

The most important findings of these preliminary on-water measurements were the observed moderate correlations between $\dot{V}O_2$ and \dot{V}_E and between $\dot{V}O_2$ and HR. It was found that both HR and \dot{V}_E were not as tightly related to $\dot{V}O_2$ as during dynamic exercise. Therefore the linear increase in $\dot{V}O_2$ with increase in

HR, seen in dynamic activities, was not reproducible during actual sailing conditions. Thus HR readings cannot be used for accurate prediction of $\dot{V}O_2$ (Vogiatzis et al., 1993b; 1994). The reasons accounting for the non linear relationship between $\dot{V}O_2$ and \dot{V}_E and between $\dot{V}O_2$ and HR will be discussed in detail in Chapters 4 and 6.

In conclusion, these preliminary on-water measurements revealed that the cardiorespiratory demands of Laser dinghy sailing are highly specific and vary considerably with the point of sailing, the wind velocity and the level of competition.

3.4.3 Aerobic and anaerobic demands of dinghy sailing at different wind velocities (Study III)

Taking into consideration the findings of study II, it was decided that the further on-water measurements planned for this study had to be performed for a given and relatively brief length of time (the brevity being necessary to minimise variation in the physiological responses due to changes in wind velocity) and while sailing without competition. Measurements had also to be performed specifically during upwind sailing since it has been confirmed that the physical demands are most strenuous on this point of sailing.

The average absolute $\dot{V}O_2$ (20.5 ± 2.5 ml kg^{-1} min^{-1}) measured was comparable to the value previously found during Laser sailing (Vogiatzis et al., 1993b; 1994). When expressed as a percentage of $\dot{V}O_2$ max (39.5 ± 6.0 %) this figure indicates that aerobic capacity is not particularly taxed in dinghy sailing (Vogiatzis et al., 1995a,b,c,d). Such an observation, in association with the typically modest $\dot{V}O_2$ max values recorded from the sailors (52.0 ± 6.0 ml kg^{-1} min^{-1}), confirms earlier suggestions that aerobic power is unlikely to be of great importance to the sailor (Shephard 1990; Gallozzi et al., 1993; Spurway and Burns 1993).

In contrast to the oxygen utilisation system, cardiac function was challenged proportionally more during sailing; the average percentage of HR max was 74 ± 10 %. This relatively high percentage of HR max in comparison to the substantially lower fractional utilisation of $\dot{V}O_2$ max confirms our earlier findings (Vogiatzis et al., 1994) and those of other investigators who showed that simulated sailing elicited high HR and BP responses which are accompanied by only modest increments in $\dot{V}O_2$ (Harrison et al. 1988; Spurway and Burns 1993). This relative tachycardia during actual sailing also confirms the findings of Blackburn (1994) who recently reported that simulated Laser sailing elicited high HR and BP responses (62 ± 13 % HR max and $172 \pm 18 / 100 \pm 14$ mmHg, respectively), whereas $\dot{V}O_2$ remained at low levels (25 ± 5 % $\dot{V}O_2$ max). The

reasons responsible for tachycardia and high MABP during hiking will be discussed in detail in Chapters 4 and 6.

Regarding the findings for [La], the literature does not offer any results that are directly comparable. Piel-Aulin et al. (1977) reported considerably higher [La] values (ranged between 4 and 8 mM) than the present results (2.3 ± 0.4 mM) at the end of sailing tests. However, their measurements were carried out at the end of a more demanding sailing test lasting 40 minutes. By contrast, in a sailing test which lasted for only 5 minutes, Marchetti et al. (1980) reported average [La] 1.8 ± 0.4 mM, i.e. slightly lower than the average value in the present study.

The results of the current study showed a linear increase in the cardiorespiratory and aerobic requirements of dinghy sailing with rising wind velocity. Because dinghy sailing demands a sustained isometric contraction of quadriceps and abdominal muscle groups, any increase in wind velocity would certainly enhance the degree of isometric effort required to counterbalance the boat (Shephard 1990) at least until the helmsman's body was maximally extended over the water. Stronger winds still have to be coped with by different techniques (such as 'feathering' the sail) which may not require more physical effort. The greater the percentage of maximum isometric effort the higher the cardiorespiratory responses (Funderbunk et al., 1974; Vogiatzis et al., 1993a). Classical studies

have reported that HR and $\dot{V}O_2$ responses during isometric exercise increase as a linear function of the tension exerted (Royce 1962; Barcroft et al., 1963; Wiley and Lind 1971). Also, it is well documented that [La] during sustained isometric contractions is closely correlated to the relative work force (Ahlborg et al., 1972; Karlsson et al., 1975; Cerretelli et al., 1976). The present findings confirm our earlier observations regarding the elevation of cardiorespiratory responses by stronger winds (Vogiatzis et al., 1993b; 1994). The results of the current study also agree with those of Pudenz et al. (1981) who demonstrated higher heart rates as the wind velocity rose during actual Laser sailing. In addition, the effects of increased wind velocity on the metabolic demands of dinghy sailing have also been studied by Stieglitz (1993) who demonstrated a good relationship between wind velocity and muscular fatigue, as deduced from post-race serum potassium levels.

In conclusion, the results of study III confirm the subjective experience of every sailor that the physical demands of dinghy sailing predominately depend on the wind conditions. However, they also make clear that, even in strong winds, dinghy sailing does not require a high aerobic capacity whereas anaerobic metabolism plays an increasing role as the wind rises (Vogiatzis et al., 1995a,b,c,d).

CHAPTER 4

4. STUDIES UNDER SIMULATED SAILING CONDITIONS

4.1 INTRODUCTION

Measurements taken under actual sailing conditions have supplied valuable information with regard to the degree to which the different energy metabolic pathways are stressed. However, because investigators cannot control variables such as wind velocity, temperature, humidity, and sea conditions, sailor's performance has been found to vary considerably in that field setting. Moreover, the 'portable' data collection systems used for field testing are generally limited due to problems associated with their electrical and transmission functions. Furthermore, there is a wide range of physiological parameters that cannot be investigated under actual sailing conditions.

For all the above reasons it becomes apparent that on-water measurements alone cannot sufficiently describe all the functional characteristics shown by the various energy systems during sailing performance. Therefore, laboratory tests which can be conducted in a controlled environment and can use protocols and equipment to closely simulate the activity of dinghy sailing should be carried out in addition to the on-water measurements. Such simulation should involve the

application of sailing-specific ergometry and should be capable of reproducing as quantitatively as possible the typical conditions which sailors experience during actual sailing. Since hiking is considered to be the major physical challenge in dinghy sailing, sailing ergometry should closely simulate all the physical and postural aspects of hiking performance.

Two types of sailing-specific ergometers are currently used to simulate hiking performance. The first and older type is the so-called '*static hiking bench*', which is usually constructed of solid wood attached firmly to the ground, thus resembling the side deck of the dinghy. Subjects are required to brace their bodies while leaning from the hiking bench with their feet under a supporting belt (the toe-strap) and their trunk inclined at a typical hiking angle (Piehl - Aulin et al., 1977; Niinimaa et al., 1977; Putman 1979; Marchetti et al., 1980; Kent 1982; Spurway and Burns 1993). This type of ergometer has the advantage that body angles and forces exerted on the toe-strap can be well controlled and therefore this kind of ergometric procedure is highly reproducible and appropriate when recording physiological parameters with which body movements are likely to interfere. However when performing measurements less likely to interfere with movements, subjects can also simulate the accommodation of wave motion by moving their bodies laterally, or they can simulate the trimming action of the sail by pulling on an elasticated rope (Kent 1982; Spurway and Burns 1993).

The second type of sailing-specific ergometer (*dynamic type*), which is the whole or part an actual dinghy, is not fixed on the ground but is free to move about a fore-and-aft roll axis, thus resembling the heeling moment caused by the interaction of the wind with the sail. The simulator's heeling moment can be generated by loading weights (Vogiatzis et al., 1993a), filling a water tank (Harrison et al., 1988), loading spring assemblies (Blackburn 1994), or even using a wind generating machine (Thomas 1981). Subjects are required to counterbalance the simulator's heeling moment by leaning their bodies out from the side of the deck opposite to that which is being pushed down. In most of these settings, trimming actions of the sail and compensation for motion caused by waves can also be simulated. In comparison to the static ergometer, proponents of the dynamic type argue that it can simulate more closely the actual boat and body movements and therefore provide more realistic information. However, standardisation and reproducibility of testing conditions is difficult to achieve due to the great variability in the movements of both simulator and subject.

The major difference between the two categories of ergometers is that in the dynamic ones sailors have to continuously counterbalance a given load and therefore their hiking ability is assessed accordingly to the effectiveness of maintaining the simulator level and also accordingly to the duration for which the required heeling moment can be adequately counterbalanced. Therefore, comparison of findings obtained from the two types of ergometric procedures is

difficult because of the different simulation settings and the testing protocols used. In addition to these problems of comparison between simulations, the validity of information derived from all sailing simulations remains questionable since there has never been any comparison of the on-water and off-water physiological responses recorded on the same subjects.

The purpose of this chapter is two fold: first to describe the procedures used to develop a sailing-specific simulator and appropriate protocol in order to closely simulate sailing in the laboratory, and second to examine in this laboratory setting the factors which cause HR and \dot{V}_E to be elevated disproportionately to $\dot{V}O_2$ during actual sailing.

More specifically, with regard to the first purpose, the principles behind the design and operation of the sailing specific simulator and the sailing specific protocol will be initially reported.

The factors accounting for the disproportionately higher HR and \dot{V}_E in comparison to the quite low $\dot{V}O_2$ figures recorded during sailing, will be examined by investigating the pattern of changes in \dot{V}_E , HR, $\dot{V}O_2$, oxygen pulse ratio, [La] and EMG activity recorded during the simulation tests.

Physiological studies over the last quarter-century (e.g. Myhre and Andersen 1971; Goodwin et al., 1972; Duncan et al., 1981; Muza et al., 1983) have suggested that in isometric exercise the distinctly higher HR, BP and \dot{V}_E responses, at equivalent $\dot{V}O_2$ values to those recorded in dynamic exercise, may be due both to reflexes arising within the exercising muscles and to "central command".

However in most of the above physiological studies, isometric effort was sustained in a single muscle group until local muscle exhaustion. By contrast dinghy hiking utilises multiple muscle masses in repetitive bouts of moderate isometric effort. Re-examination of the mechanisms in this applied context was therefore considered appropriate.

Finally, and in addition to the above purposes, this chapter will comment on the external validity of the simulation procedure by comparing a number of physiological measurements carried out during both the simulation and the actual sailing tests on the same subjects.

4.2 PROCEDURES AND MATERIALS

By sailing-specific ergometry we imply the multi-disciplinary science-based evaluation of the sailor in conditions that simulate as closely as possible a

competition or phases of training similar to competitions. In particular the following parameters were considered prior to the design of the sailing simulation procedure:-

1. The type of sailing craft the subjects were racing.
2. The actual posture sailors adopt during sailing.
3. The frequency of body movements during sailing.
4. The duration of the test in order to simulate the energy sources used by sailors in their performances.
5. The kinds of stresses that sailors experience during actual sailing.

4.2.1 Construction and operation of the dinghy simulator

The dinghy simulator comprised two major components: the deck and hull assembly, and the base framework. The deck of the simulator was constructed using the same dimensions as that of a Laser dinghy, so that the posture normally adopted by the subjects during actual sailing was closely reproduced (Figure 8).

The deck and hull assembly were constructed using a square tubular framework and plywood sections. The dimensions (length by width) of the deck and the hull were 43 cm x 51 cm and 137 cm x 51 cm respectively.

The base framework was largely constructed of mild steel angle section. The length, width and height of this framework were 189 cm, 60 cm and 71 cm, respectively.

In order to simulate the heeling moment generated by the wind's interaction with the sail, the simulator was made to pivot about a central point by using twin steel axial structures located by large diameter roller bearings mounted in alloy housings. Pivoting about the central point was made possible by the following methods:-

- Calibrated weights were applied to the opposite side of the simulator from the subject. The appropriate load was determined during a series of familiarisation tests and was based on the relationship between each subject's body mass and the applied load which balanced it when the simulator was level (Figure 8).
- A 'mainsheet' rope which was held at one end by the subject passed through a series of pulleys to terminate in a spring assembly that was activated every time the subject pulled in the mainsheet at the onset of each test (Figure 8).
- An additional spring assembly attached at one end to the base structure and at the other to the end of the hull assembly remote from the subject, provided mechanical damping to the moving hull assembly. This spring

helped to smooth out the movements of the hull just as in actual sailing conditions (Figure 8).

A switch mounted on the lower frame was adjusted to provide a signal to a BBC computer indicating any deviation from level by the upper assembly, of more than $\pm 1.5^\circ$. A computer programme monitoring this signal provided the basis for the test protocol according to which the subject was required to maintain the hull section level. For convenience and safety, the moving section was also limited by means of mechanical stops to a forward rotation of 10° and backward rotation of 5° . Finally, a load cell attached to the toe-strap monitored the force applied at this point and the output was displayed on a digital display unit and recorded on a pen recorder (Figure 8).

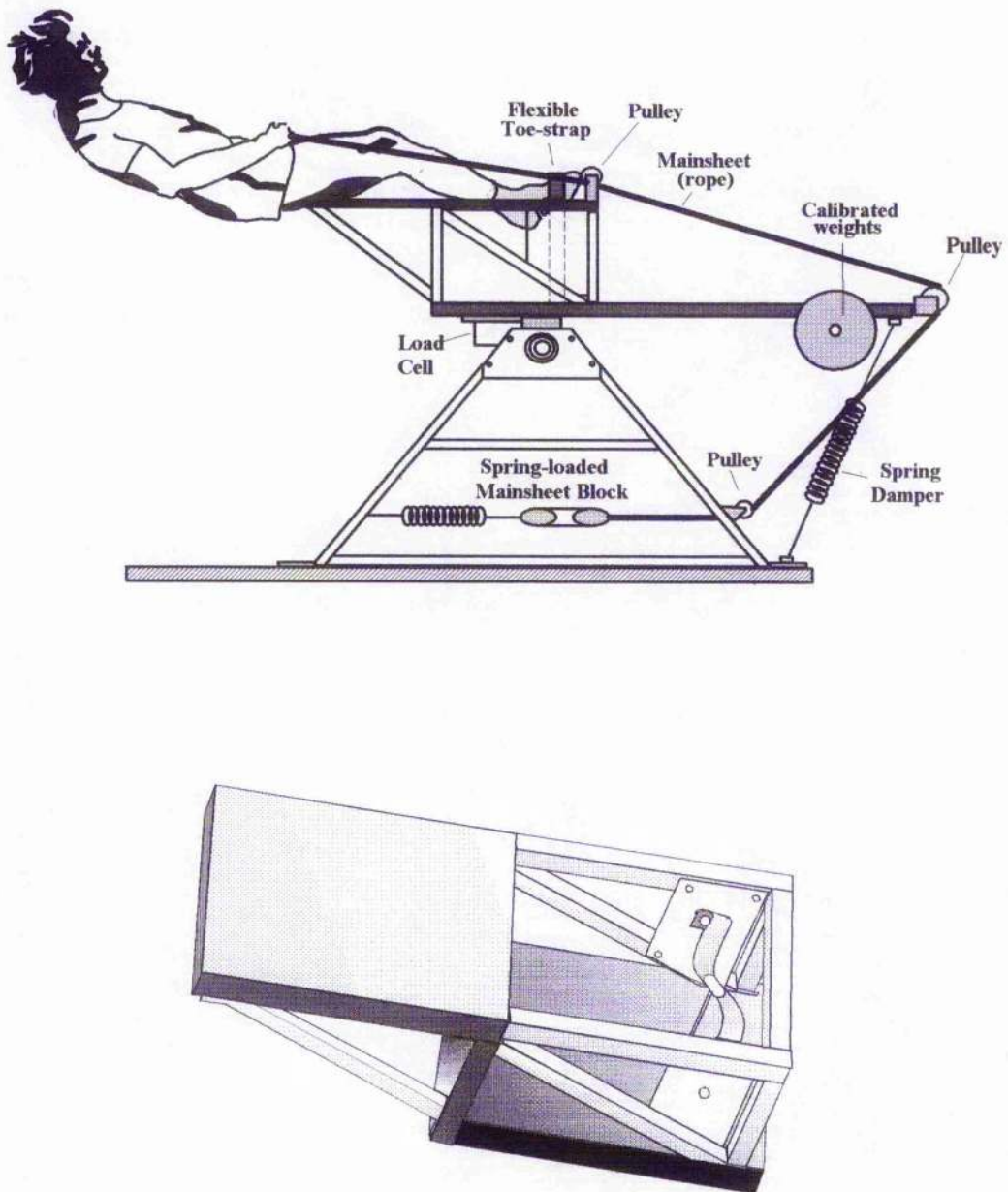

Fig. 8. Diagram of the dinghy simulator used to study the isometric posture sailors adopt while sailing and a drawing of the 'deck and hull' arrangement viewed obliquely from above.

4.2.2 Simulation procedure

The dinghy simulator, together with a computer-generated protocol, was used to reproduce in the laboratory the major physical challenge of single-handed dinghy sailing: the hiking effort. The main activities simulated were:-

- Maintaining the boat in an upright position by counterbalancing the imposed heeling moment.
- Trimming the sail by using the 'mainsheet'.
- Compensating for wave motion and fluctuations in wind velocity.

Subjects were required to maintain the simulator level by hooking their feet under the toe-strap mounted on the base of the deck and by holding their bodies over the edge of the deck (hiking), thus balancing the 'heeling moment' (Figure 8).

The subjects simulated mainsheet activity (trimming the sail) by applying additional force, via a nylon rope and spring-loaded block assembly, to the end of the deck supporting the weight system. Any increase in rope tension had to be accommodated by a corresponding increase in hiking effort by the sailor. The mainsheet, once set, could be locked in position and the mechanism was then sensitive enough to respond to small body movements which could upset the balance (heeling moment) of the simulator.

A computer program provided visual and auditory information to the subjects to assist them in maintaining the optimum position of the simulator, and also determined the sequence of the sideways movements they performed in order to mimic the movements made during actual sailing in moderate and strong winds. The sequence of movements was established by recording with a video camera the frequency of fore and aft movements typically made by sailors as they accommodated wind and wave activity during the on-water tests described in Chapter 3.

Video recordings also allowed the estimation of the average time spent during upwind sailing and the time the hiking posture was continuously maintained before crossing the boat during tacking. This information was used to establish the duration of the experimental protocol.

4.3 METHODS

4.3.1 Subjects

Eight male Laser sailors (the same individuals who participated in study III - Chapter 3) participated in this study. The subjects' mean (\pm SD) age, height and body mass were 23 ± 5 years, 178 ± 8 cm and 74 ± 14 kg, respectively.

4.3.2 Pilot and Familiarisation Tests

A series of pilot trials was conducted some months before the actual simulation tests. During this period a relation between subjects' body mass and acceptable hiking loads was established. The regression equation which was derived from this was as follows: $Y = -23.5 + 0.595 X$, where Y = test load and X = each subject's body mass. (The main explanation of '-23.5' offset is the constant spring contribution to effective load). Use of this equation smoothed out the effect of different individual tolerances of effort, while retaining full empirical allowance for differences of body mass.

During the pilot tests, $\dot{V}O_2$, HR and [La] responses were monitored from each subject at standard time intervals. From the data obtained, a decision was made as to the optimum duration the actual experiment should last in order to stress the energy metabolic systems to a degree similar to that during actual sailing.

Five days prior to undertaking the experimental protocol, each subject practised on the simulator to become familiar with the required procedure and the load derived from the above regression equation against which he would be required to hike.

4.3.3 Experimental protocol

Each subject was asked to complete four successive 3-min hiking bouts, separated by approximately 15 s intervals to simulate tacking. Simulation of tacking involved sitting in from the hiking posture and 15 s later moving back out to a full hiking position. This discontinuous type of protocol was considered realistic because it closely mimicked the average time the hiking effort was maintained during actual sailing, and practical because it allowed frequent blood samples to be taken during the tacking phases. Simulation of accommodation to wave motion was accomplished by setting the frequency of sideways movements at 30 per minute. While hiking, subjects were required to keep the force exerted on the toe-strap as constant as possible (and so the simulator effectively level) and to reproduce the same force across the four hiking bouts.

4.3.4 Measurements of respiratory variables

Subjects breathed through a mouthpiece attached to a low resistance respiratory valve. Expired gases were collected for each of the following 3 min periods into successive Douglas bags: immediately before the start of exercise, throughout each of the four bouts, and during the first 3 min of recovery. Immediately after collection, fractional concentrations of O_2 and CO_2 from each

gas sample were analysed using O₂ and CO₂ analysers. A dry gas meter was used to measure the volume of expired gas, which was corrected to STPD. These values were used to calculate the mean values of $\dot{V}O_2$, $\dot{V}_E/\dot{V}O_2$ and the oxygen pulse ratio over each period of 3 minutes. Percentage CO₂ at the mouth was measured throughout by drawing a continuous sample from the mouthpiece through a CO₂ analyser. End-tidal values were converted to P_{ET,CO₂} by correcting for water vapour and barometric pressure. V_I was also measured by pneumotachography and together with the % CO₂ was recorded throughout on the same multichannel recorder as EMG activity (see below). Inspired minute volume (\dot{V}_I) was calculated from cumulative V_I over 15 s periods.

4.3.5 Measurements of cardiovascular variables

HR was monitored throughout by a Sports Tester PE 3000. HR values averaged for each period of 3 min were used to calculate the oxygen pulse ratio for each hiking bout. Blood pressure was measured immediately before the first bout and immediately after the last bout using a standard clinical sphygmomanometer

4.3.6 EMG sampling and analysis

EMG activity was recorded from rectus femoris (RF) of the right leg and biceps brachii (BB) (short head) of the right arm respectively. The EMG activity was picked up by pairs of skin electrodes with contact areas of 0.65 cm^2 , placed 15 mm apart in a line parallel to the muscle axis. Amplification of the EMG signals was performed by high gain, high impedance differential amplifiers. The amplified signals were full-wave rectified, integrated and recorded on a chart recorder and the area under the integrated signals was determined throughout each 3-min exercise bout. The average IEMG activity for each bout was expressed as a percentage of the maximum activity (% max. IEMG) recorded during the strongest of three brief voluntary maximal contractions (MVC) of that muscle group performed by the subject before the hiking experiment. The area under the IEMG trace was also determined for the initial 15 s of each hiking bout, and this was used as the 'baseline' value for that bout. The IEMG activity recorded throughout the four successive hiking bouts was taken as an indicator of changes in the neurogenic drive to the exercising muscles, since it has been demonstrated that this computation can be used as a quantitative estimate of the motor neurone pool activation (Komi and Viitasalo 1976).

4.3.7 Blood sampling

Capillary blood samples were taken from a finger tip of the subject's left hand immediately before the beginning of the first hiking bout, during the 15 s interval following each bout, immediately after the end of the last bout and after 3 min of recovery.

4.3.8 Other measurements

Perceived exertion was rated by the subject immediately after the end of each bout using the category-ratio scale (Borg 1982). The force exerted to the toe-strap was continuously recorded on a pen recorder.

4.3.9 Statistical Analyses

The probability plot correlation coefficient test for normality revealed that data recorded for all variables were normally distributed. One-way ANOVA with repeated measures, followed by Tukey's pairwise comparison tests where appropriate, were used to determine if changes in the recorded physiological variables were significant. Differences between means were estimated using t-tests for independent samples. Pearson's product moment correlation coefficient was applied to express correlations between variables. Statistical significance

for all statistical procedures was accepted at $P < 0.05$. All data are presented as mean \pm S.D.

4.4 RESULTS

4.4.1 Respiratory variables

Across the 4 hiking bouts, the 3-minute $\dot{V}O_2$ and \dot{V}_E significantly increased, while P_{ET,CO_2} decreased significantly (Figure 9). During the first bout the rise in $\dot{V}O_2$ was abrupt and the increase from pre-exercise levels to bout 1 and from bout 1 to bout 2 was large compared to the further increases in bouts 3 and 4 (Figure 9A). The average value for $\dot{V}O_2$ over all four bouts was only 1.04 ± 0.05 l min^{-1} , and even the last bout considered alone averaged only 1.25 ± 0.06 l min^{-1} . The increases in \dot{V}_E across the four bouts (Figure 9B) were such that the ratio $\dot{V}_E/\dot{V}O_2$ increased significantly (Figure 9C). This was consistent with the hyperventilation indicated by a progressive decrease in P_{ET,CO_2} across the bouts (Figure 9D).

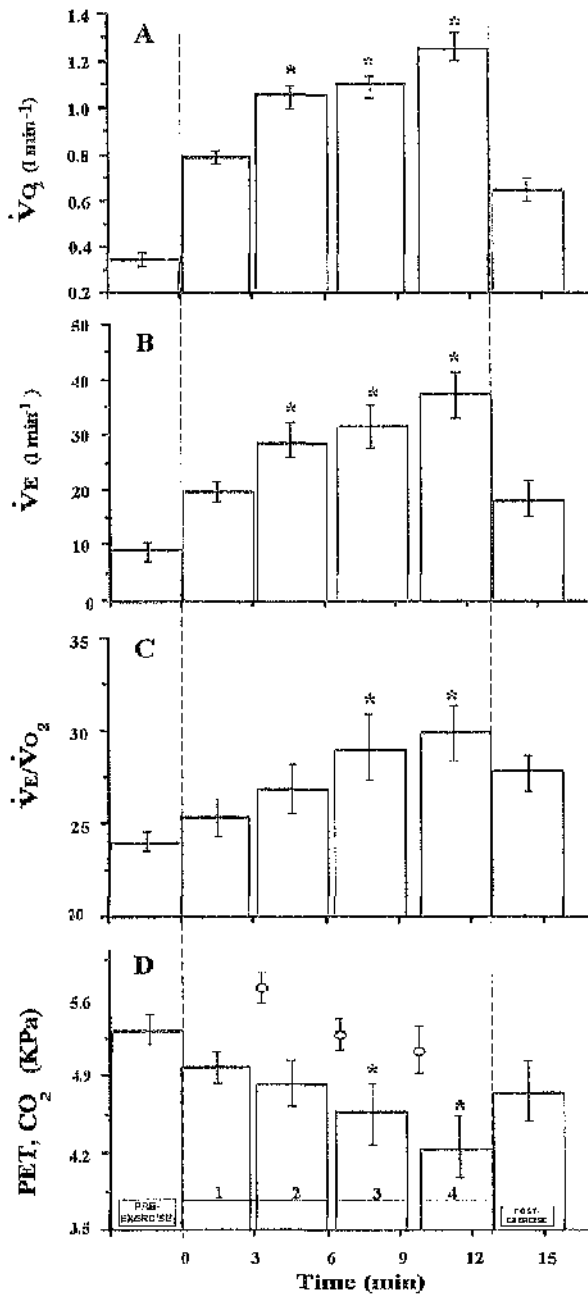

Fig. 9. Changes over the 4 bouts and during recovery; lines indicate means (\pm SD) for 3-

min averages for A: $\dot{V}O_2$, B: $\dot{V}E$, C: $\dot{V}E/\dot{V}O_2$ and D: for P_{ET}, CO_2 . For D,

values are shown also for the 15 s intervals. * Significantly different from bout 1.

The continuous breath-by-breath record (Figure 10) revealed more detail of the pattern of ventilatory changes within and between bouts. Hyperventilation increased to reach the maximum for each bout at the end of its 3 min period. During the 15 s intervals, there was an immediate decrease in \dot{V}_T , which often started (as in the trace illustrated) with a prolonged expiratory interval. In the same 15 s periods P_{ET,CO_2} increased by 0.4 - 0.7 KPa (3 - 5 mmHg) from the mean of the preceding 3 min and then, in the next 3 min, fell to values lower than before, (Figures 9D, 10).

The particular example in Figure 10 (top panel) shows ventilation increasing again in the first 25 s of resuming exercise, bringing down the P_{ET,CO_2} from a peak at the end of the rest interval to a level similar to that at the end of the preceding (3rd) bout. During the next 15 s this hyperventilation was transiently reversed, with a consequent small increase in P_{ET,CO_2} ; thereafter hyperventilation progressed to a new maximum at the end of the 4th bout. This pattern was typical, with minor variations in timing, such that the group data for each of the bouts 2, 3 and 4 showed the average ventilation over the whole of the first minute to be lower than that over the first 15 s (Figure 11A).

The final cessation of exercise was initially characterised by an immediate fall in ventilation and consequent rise in P_{ET, CO_2} (Figure 10 - bottom panel), as in the 15 s rest periods described above. However, after 20 to 30 s there was usually a transient secondary increase in ventilation, before a variable return towards the resting state.

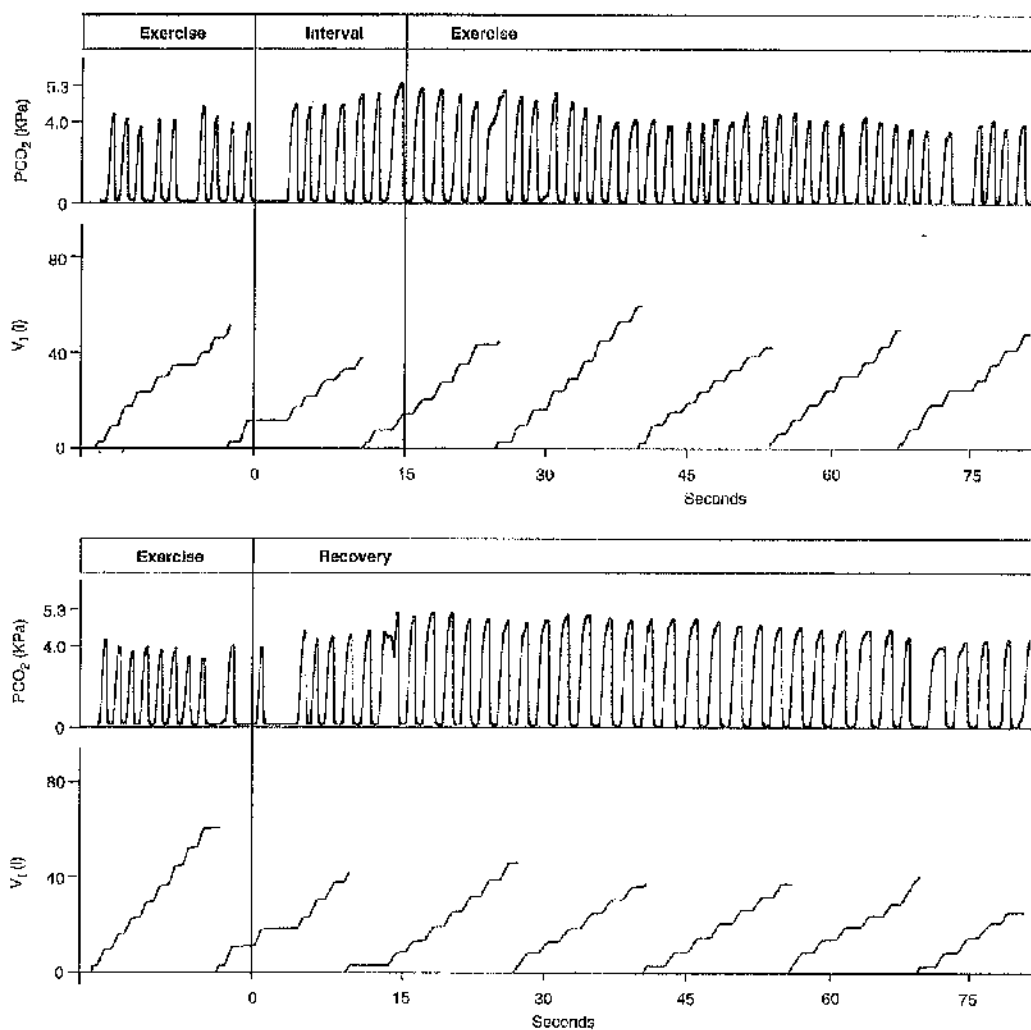

Fig. 10. Breath-by-breath records for a representative subject of partial pressure of CO_2 at the mouth (PCO_2) and V_t across the bout 3-interval-bout 4 transition (top panel) and across the bout 4-recovery transition (bottom panel).*

4.4.2 Cardiovascular variables

HR significantly increased across the 4 hiking bouts and did not return to the pre-exercise levels by the end of the studied recovery period (Figure 12D). HR was also significantly correlated with both the IEMG activity ($r = 0.71$) and \dot{V}_I ($r = 0.79$). Over all bouts the average value for HR was 112 ± 6 beats min^{-1} ; during the last bout it averaged 126 ± 8 beats min^{-1} .

During the first bout the rise in the oxygen pulse was abrupt and the increase from pre-exercise levels (4.5 ± 0.5 ml min^{-1}) to bout 1 (9.0 ± 1.2 ml min^{-1}) and from bout 1 to bout 2 (11.9 ± 2.2 ml min^{-1}) was significant. During bouts 3 and 4, however, this increase in the oxygen pulse was reversed: in neither of these later periods did it differ significantly from that of bout 1 (Figure 12 B).

The MABP significantly increased from 12.0 ± 0.3 KPa (90 ± 2 mm Hg), pre-exercise to 16.0 ± 0.5 KPa (120 ± 4 mmHg) by the end of the last hiking bout.

4.4.3 EMG analysis

The average % max. IEMG activity recorded from rectus femoris was significantly increased across the 4 bouts (Figure 12A). During the first minute of each bout the activity did not significantly increase above that bout's 'baseline' level (that of the initial 15 s of the bout) (Figure 11B). By the end of

the second and third minutes of hiking exercise, in bouts 3 and 4, the average % max. IEMG activity had significantly increased above baseline. Also, with successive bouts the magnitude of the rise above baseline levels in the activity of rectus femoris increased progressively at minutes 2 and 3 (Figure 11B). By contrast, the % max. IEMG activity recorded from biceps brachii did not change significantly across the four bouts (Table 4).

Reasons will be put forward later for proposing that control of \dot{V}_1 is dominated by different influences during the early seconds of exercise resumption than those operating from about half a minute onwards. In this connection therefore, it is relevant to note that \dot{V}_1 increased approximately in parallel with IEMG from the end-of-minute 1 average, through the rest of each bout. The correlation coefficient between the two parameters for the 4 bouts was 0.85.

4.4.4 Blood lactate analysis

The blood lactate results demonstrated a relatively large inter-subject variability. Although the average [La] was elevated almost two-fold by the first hiking bout, the rise fell short of statistical significance. Nor did [La] change significantly across the four bouts. However, after the end of bouts 3 and 4 [La] was significantly higher than the pre-exercise value, and it was significantly higher still after 3 min of recovery (Figure 12C).

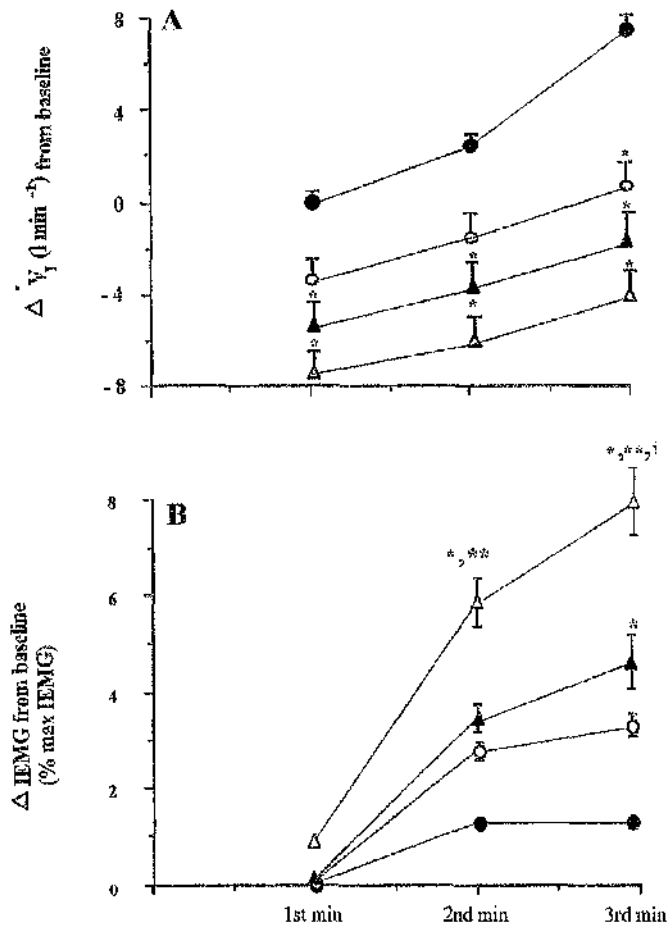

Fig. 11. **A:** for \dot{V}_1 and **B:** for the % max. IEMG recorded from rectus femoris, points are the average values over each minute of each bout, expressed as changes from the first 15 s ('baseline period') of each bout (bout 1 filled circles, bout 2 open circles, bout 3 filled triangles and bout 4 open triangles). * Significantly different from bout 1. ** Significantly different from bout 2. † Significantly different from bout 3.

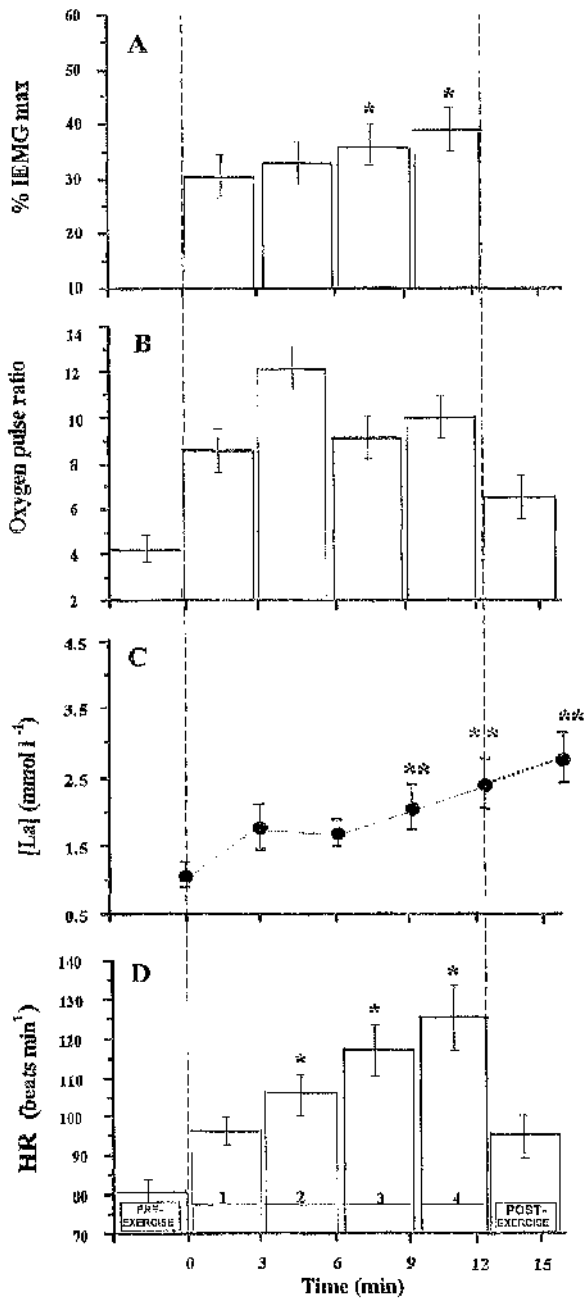

Fig. 12. A: the % max. IEMG, B: the oxygen pulse ratio and D: HR values refer to averages (means \pm SD) over 3 min periods. C: [La] refer to the end of each bout.

* Significantly different from bout 1. ** Significantly different from pre-exercise.

4.4.5 Other variables

RPE was significantly increased across the four hiking bouts, whereas no significant changes in force exerted on the toe-strap were observed during the four bouts (Table 4).

4.4.6 Comparison of measurements under actual and simulated conditions

The average percentages of maximum $\dot{V}O_2$ and HR obtained from the simulation tests were lower than those recorded from the on-water tests (Figure 13). However, when the oxygen pulse ratio, the $\dot{V}_E/\dot{V}O_2$ and [La] values recorded from the simulation tests were compared to those recorded during actual sailing (Figure 14), no differences between those values were observed.

	Bout 1	Bout 2	Bout 3	Bout 4
Force (N)	134 ± 15	131 ± 15	127 ± 14	129 ± 16
% maximum IEMG (B B)	22.8 ± 3.1	22.5 ± 2.5	23.5 ± 4.0	24.2 ± 5.0
RPE	10 ± 1	13 ± 1	15 ± 2	16 ± 2

Table 4. Means (\pm SD) for variables not illustrated graphically: the force exerted on the toe-strap of the simulator, the % max. IEMG activity from biceps brachii (BB), and the RPE - all recorded during the 4 hiking bouts.

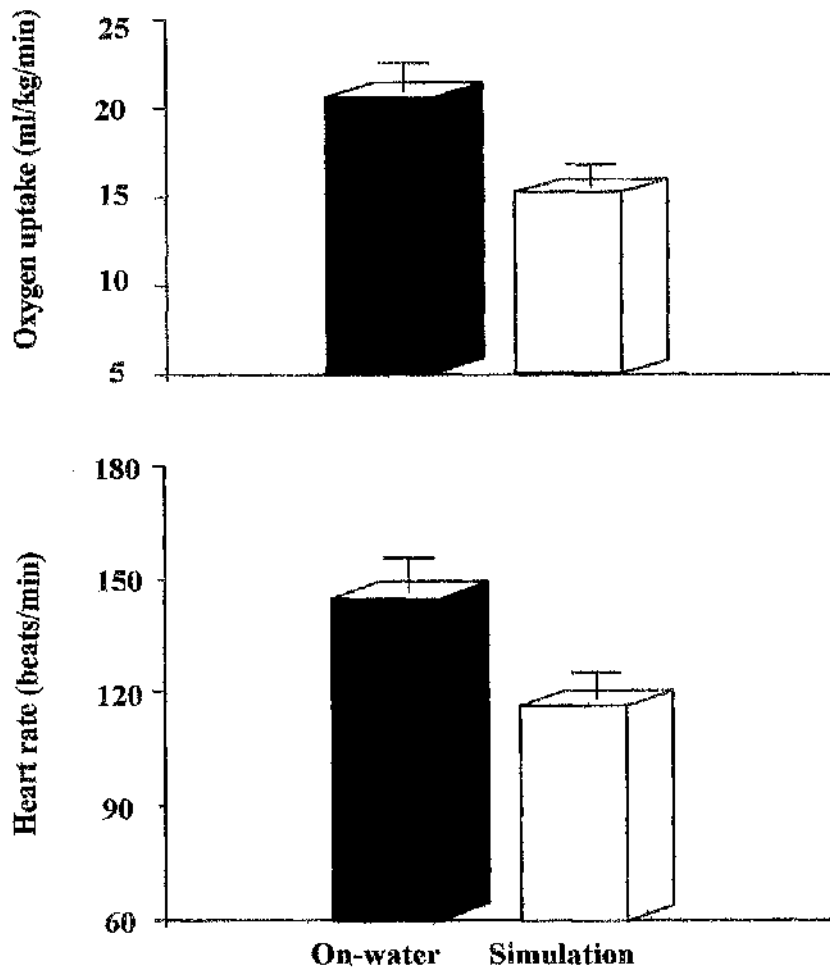

Fig. 13. A comparison of the average percentages of maximum values for oxygen uptake and heart rate obtained from the simulation and on-water tests in moderate and strong winds.

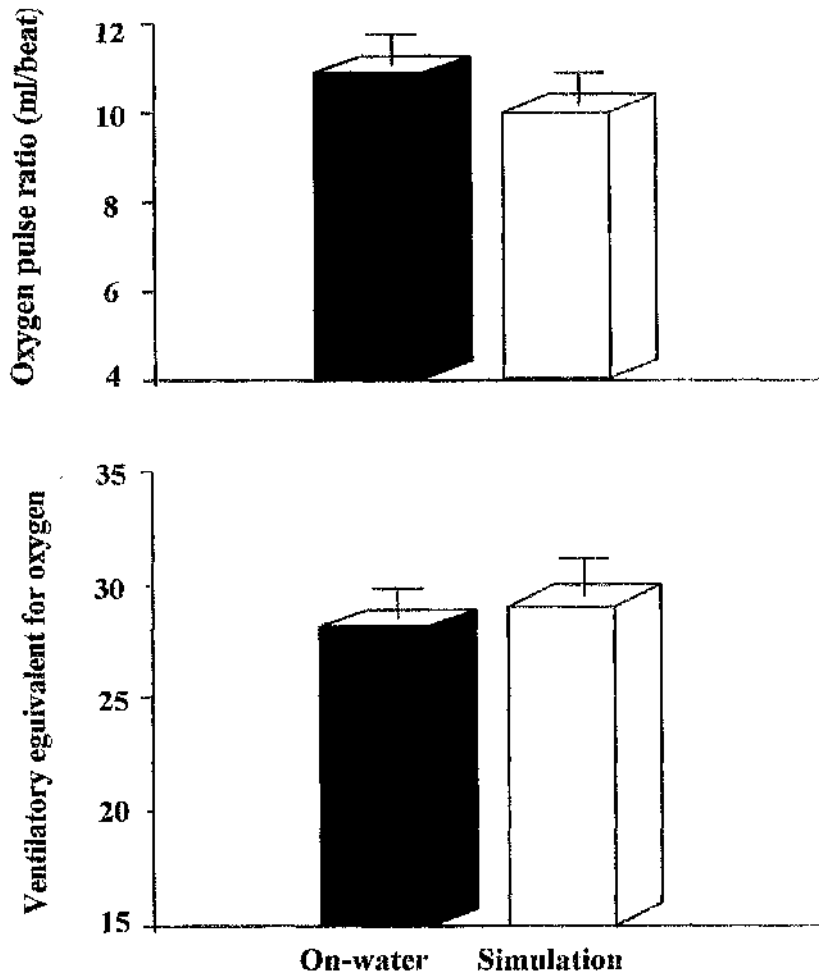

Fig. 14. A comparison of the average oxygen pulse ratio and ventilatory equivalent for oxygen recorded from the simulation and on-water tests.

4.5 DISCUSSION

The main purpose of this investigation was to study those factors responsible for elevating HR and \dot{V}_E proportionally more than $\dot{V}O_2$, during a sailing simulation test which was designed to mimic the actual dinghy sailing conditions as closely as possible. EMG and $[La]$ measurements were carried out, in addition to the cardiorespiratory recordings, in order to identify possible links between the local neuromuscular and chemical events and those which control the cardiovascular and respiratory adjustments during hiking exercise.

The comparison of $\dot{V}O_2$ and HR measurements between laboratory and real sailing conditions revealed that the cardiorespiratory responses recorded during the simulation tests were lower than those monitored during actual sailing. This suggests that the simulation tests were less physically demanding than those during actual sailing. However, this may not be the case since previous documented studies indicate that performance under actual sporting or competitive conditions can cause extra physiological and/or psychological stresses leading to an elevated HR and increased energy expenditure which are not consequences of the studied physical activity itself (Astrand and Rodahl 1986). These authors cite the following example, which provides evidence in support of this suggestion: Agnevik et al. (1969) studied the elite alpine skiers in this event, both in the laboratory and in connection with regular international

competitions. One of the foremost skiers in the world in special slalom, Bengt-Eric Grahn, was included in that study. His maximal HR measured on the cycle ergometer was $207 \text{ beats min}^{-1}$. With the aid of telemetry, his HR was recorded before and during a competitive slalom race. At the start of the race his HR was more than $160 \text{ beats min}^{-1}$. This high HR was no doubt due to emotional factors and some degree of nervousness at the start of the race. (It should also be pointed out that prior to the start of the race, the skier skis the track uphill in order to become familiar with the track. This physical effort could also be responsible to some degree for the elevated HR seen prior to the start of the race and possibly for elevating the metabolic rate). During the first minute of skiing his HR quickly rose to over $200 \text{ beats min}^{-1}$, to the same maximal HR that was obtained at a maximal load on the cycle ergometer. Although his HR increased at "supramaximal" work rates on the cycle ergometer, in that case the increase occurred however more slowly than it did during actual skiing performance, a difference which must be attributed to an "extra" physical and psychological factors.

Similarly, during the actual sailing experiments the cardiorespiratory responses of the subjects were higher than those recorded in the laboratory due probably to a number of reasons associated not only with psychological factors but also with a greater deal of physical activity and environmental conditions. More specifically, cold and greater arm and body-movements, performed to

accommodate the frequent changes in wind and wave conditions, certainly contributed to the elevated $\dot{V}O_2$, \dot{V}_E and HR responses seen in that setting. Similarly the oxygen pulse and the $\dot{V}_E/\dot{V}O_2$ confirm that $\dot{V}O_2$, \dot{V}_E and HR rose in proportion one to another. In the absence of these "extra" physical and environmental factors during the laboratory tests the lack of significant differences in the oxygen pulse and the $\dot{V}_E/\dot{V}O_2$ found between the on-water (oxygen pulse: 11 ± 0.7 ml min⁻¹; $\dot{V}_E/\dot{V}O_2$: 26.8 ± 1.2) and the simulation tests (10 ± 0.6 ml min⁻¹ and 27.8 ± 1.0 , respectively) suggests however that there were not greater tachycardia and hyperventilation on-water (Vogiatzis et al., 1995b).

Any suggestion that the simulation tests were not less physically demanding than the actual sailing tests, derives principally from the results from two of the other measurements. The average RPE (16 ± 2) and the personal observations of the sailors at the end of the simulation tests were indicative of hard effort similar to that typically experienced by them on-water. Also, the [La] at the end of the simulated tests (2.8 ± 0.3 mM) was closely comparable to that at the end of the tests in strong winds (3.0 ± 0.6 mM) suggesting that the actual hiking effort (the chief endurance challenge) was well simulated (Vogiatzis et al., 1995b,d). Therefore, since there is strong evidence that the kinds of stresses sailors experienced during actual sailing were similar to those during the laboratory

tests, the latter could reveal reliable and accurate information with regard to the physiological demands of the sport of dinghy sailing.

The physiological demands of dinghy sailing are highly specific and vary considerably with the type the boat (Shephard 1990) and the counterbalance force it requires (Gallozzi et al., 1993). Therefore the results of the present investigation can be quantitatively compared only with those of other studies which involved hiking performance in the same class of dinghy - the Laser. Average values for $\dot{V}O_2$, HR, MABP and post-test [La] recorded from the present investigation are in agreement with those obtained in a recent study (Blackburn 1994) of hiking on a Laser simulator ($1.12 \pm 0.22 \text{ l min}^{-1}$, $118 \pm 25 \text{ beats min}^{-1}$, $16.4 \pm 2.0 \text{ KPa}$ [$123 \pm 14 \text{ mmHg}$] and $2.3 \pm 0.8 \text{ mM}$, respectively).

Although the findings of this investigation can only be directly compared to those of Blackburn 1994, it should be emphasised however that they point to conclusions similar to those of other investigators. Most specifically, Spurway and Burns (1993) clearly demonstrated that at equivalent $\dot{V}O_2$ values recorded during submaximal cycling and hiking on a hiking bench, HR and \dot{V}_E were respectively 1.57 and 2.79 times higher during hiking, thus showing that the circulatory and ventilatory adaptations to hiking exercise were clearly different from those prevailing in dynamic exercise. The results of the present investigations tally with the findings of Spurway and Burns (1993) by showing

that HR and \dot{V}_E increase disproportionately to the $\dot{V}O_2$ demands (disproportionally by comparison with dynamic exercise) during hiking (Vogiatzis et al., 1994; 1995a,b,c). The reasons for such a disproportion are as follows:-

It has been well documented that the hiking posture is sustained by isometric contractions, mainly of the leg musculature. In particular, the quadriceps muscle groups have been shown to exhibit the most pronounced activity (Piehl-Aulin et al., 1977; Marchetti et al. 1980). In the present study the force exerted on the toe-strap of the sailing simulator did not change significantly across the four hiking bouts (an observation consistent with the fact that the simulator was held level, and body angles did not noticeably change); nevertheless, the recorded IEMG increased. In muscles generally, EMG activity has been shown to increase when constant isometric tension is sustained in the face of developing fatigue (Edwards and Lippold 1956; Lloyd 1971; Lind and Petrofsky 1979): as the exercise continues, greater motor unit activity (associated with increased voluntary effort) is required to maintain the given force (Goodwin et al., 1972). Increase in the IEMG activity of quadriceps muscle groups during hiking has indeed been reported before, and attributed to recruitment of additional motor units (Vogiatzis et al., 1993a). Furthermore, in that study spectral analysis of the myoelectric signals was available and a shift towards lower frequencies was evident - a strong indication of developing fatigue (Fallentin et al., 1993). Fatigue in the present study was clearly cumulative, as manifested by the

increases in the IEMG activity during each successive hiking bout, confirming that the short tacking intervals separating the bouts were not sufficient for adequate recovery (c.f. Funderburk et al., 1974).

Although the present experiments did not provide direct information as to the mechanisms of the fatigue the subjects experienced, it is likely (as already noted) that the level of isometric contraction of the quadriceps muscles restricted their perfusion by mechanically compressing the intramuscular blood vessels (Edwards et al., 1972). The magnitude of the increase in MABP across the hiking bouts and the steady increase of HR were indicative of levels of isometric tension at which blood flow through the muscles is markedly impaired (Lind and McNicol 1967). Further support for such a suggestion is also provided by the small increase in $\dot{V}O_2$ observed after the end of the second bout implying that only slightly more oxygen was utilised by the active muscles, possibly due to the virtual blockage of these muscles from the general circulation. This contraction-induced ischaemia is known to result in an increase in lactic acid production which in turn diminishes the muscle pH (Sahlin et al., 1975) and decreases the muscle's contractile force (Sahlin 1986). Other substances released by active fibres, notably potassium ions, will also tend to be trapped within the muscle interstitial fluid and contribute to force-decline (Hnik et al., 1986) instead of distributing throughout the body. Decrease in muscle pH and elevated extracellular potassium concentration could, however, explain more

than the need for further recruitment. Both are likely to stimulate the receptive fields of chemosensitive groups III and IV afferent fibres, which have been shown to form functional connections with the cardiovascular and respiratory centres, and activation of these afferents could reflexly increase HR, BP and \dot{V}_E (McCloskey and Mitchell 1972; Tibes 1977; Tallarida et al., 1981; Schibye et al., 1981).

In addition to this enhancement of cardiovascular and respiratory drive by muscle chemoreflexes, the increases in the IEMG activity directly reflected increases in the efferent neural activity required to maintain the force exerted on the toe-strap. The question arises, whether this is elicited reflexly, or by enhanced "central command". In the best studied situation, sustained maximal voluntary contraction, it is clear that reflex activity slows motoneurone firing and so reduces IEMG (Bigland-Ritchie et al., 1986). There are no grounds for supposing that the reflex influences change their sign between submaximal and maximal efforts. Central command must therefore be presumed to be responsible for the *increased* IEMG activity seen in fatigued submaximal isometric contractions. Now enhanced central command descending from higher centres to exercising muscles is itself considered to provide a drive to increase HR, BP and \dot{V}_E (Goodwin et al., 1972). The present investigation suggests such a direct association between the neural output to the muscles and the cardiorespiratory responses since increases in HR and \dot{V}_I across the four

hiking bouts were strongly correlated with increases in the IEMG activity ($r = 0.71$ and 0.85 respectively). The fact that HR and \dot{V}_I were in turn significantly correlated ($r = 0.79$) across the successive hiking bouts is compatible with the concept that a part of the enhanced motor command signal from the cortex stimulates brainstem cardiovascular as well as respiratory centres (Goodwin et al., 1972).

What the data from this study show unequivocally is that the cardiovascular and respiratory drives during these periods of hiking, as in other forms of isometric exercise (Myhre and Andersen 1971; Duncan et al., 1981; Assmussen 1981; Muza et al., 1983; Poole et al., 1988), exceeded those required by aerobic metabolism (Vogiatzis et al., 1995e,f). The increases in HR and \dot{V}_E recorded throughout the hiking bouts were disproportionately greater than the increments in $\dot{V}O_2$, and the concurrent hypocapnia and decrease in the oxygen pulse ratio, after the end of the second bout, confirmed that marked tachycardia and hyperventilation were taking place in these laboratory simulations, to the same extent as they did in actual sailing (Vogiatzis et al., 1995a,b). Tachycardia and hyperventilation were increasingly pronounced during each successive bout, and especially during the last two bouts - paralleling fatigue. The excess of HR and \dot{V}_E increases over those in $\dot{V}O_2$ is in keeping with the concept that the cardiovascular and respiratory drives during the main parts of each exercise-bout involved factors other than those which match the cardiorespiratory responses to

metabolic rate in moderate dynamic exercise (Vogiatzis et al., 1995a,b,c). The two categories of neurogenic stimulus discussed above (chemoreflexes and central command) are both candidates for such excess drives (Goodwin et al., 1972).

The RPE also significantly increased across the four bouts, due predominantly to increased sensation of fatigue and pain in the quadriceps muscle groups. These sensations might have activated the cardiac and respiratory centres via the cortex, adding to the tachycardia and hyperventilation (Duncan et al., 1981). In addition, the same effects could arise by an indirect mechanism: pain and fatigue can result in increased outflow of catecholamines, which are in turn capable of inducing tachycardia as well as hyperventilation (Whelan and Young 1953).

Concerning events within the individual hiking periods, IEMG activity did not increase during the first minute of any bout, even though it increased markedly thereafter in bouts 3 and 4. The delayed increase in these bouts could be attributed to reactive hyperaemia having occurred during the interval phases and briefly restored blood flow through the muscles (Sjogaard et al., 1988); thus fatigue would be held in abeyance for a short period, before starting to increase again.

Later in these same 'first minutes', ventilation actually decreased from its levels of the first 15 s, suggesting that the initial increase was not solely evoked by the

start of exercise, but that some other stimulus acted to increase ventilation about the time of transition to the next bout and during its initial 15-20 s (Figure 10). The possibility that the onset of muscular effort at the beginning of each hiking bout could have been entirely responsible for this secondary increase in ventilation can be excluded since a similar secondary rise occurred early in the recovery period. Instead this drive to breathe, some seconds after the cessation of the isometric exercise, could be related to the liberation of metabolic products into the systemic circulation which, during the exercise period, were presumably trapped in the contracting muscles as a consequence of the impeded blood flow (Poole et al., 1988). Such a suggestion can be further supported by the fact that the observed increase in P_{ET,CO_2} at the cessation of hiking exercise always just preceded the secondary rise in ventilation. Transient venous CO_2 loading is reflected in an increase in alveolar and arterial P_{ET,CO_2} and can increase ventilation through stimulation of peripheral chemoreceptors (Phillipson et al., 1981). It is doubtful that lactic acid, acting either directly or by displacement of CO_2 from bicarbonate buffers, contributed substantially during the main part of each sequence since $[La]$ did not increase significantly from its respective pre-exercise levels until the end of the bouts 3 and 4. The small increase in $[La]$ observed across the four bouts could reflect a small degree of seepage from regions of the contracted muscles where the blood flow was not completely impeded (Saltin et al., 1981). However, the slightly raised concentration seen at the end of bouts 3 and 4 is similar to that observed during contraction by Poole

et al., (1988), who considered it too small to contribute significantly to ventilatory drive at that stage. By contrast they did propose that a greater [La] rise and consequent fall in arterial pH might contribute to hyperventilation during recovery. Therefore it is suggested that blood with high CO₂ and low O₂ content, together perhaps with other metabolites such as potassium ions, having been largely trapped in the contracting muscles, surged into the circulation when each bout ceased and transiently stimulated the arterial chemoreceptors (Vogiatzis et al., 1995e,f).

Finally, it must not be overlooked that $\dot{V}O_2$ rose across the four hiking bouts, particularly during the first two. This suggests first that blood flow through the quadriceps and other contracting muscles, though substantially impeded, was not totally so; and second that additional motor units or synergistic muscles were recruited (Myhre and Andersen 1971; Wiley and Lind 1971; Kilbom and Person 1982), albeit to low percentages of their maximal activity, as fatigue developed. Such additional muscle activation was perhaps present, not only in quadriceps but also in the biceps brachii, which showed a non significant trend towards an increased activity across the four exercise bouts.

The principal new information the present investigation offers is the evidence of a direct association between the onset and the magnitude of muscle fatigue in quadriceps and the cardiovascular and ventilatory drives (Vogiatzis et al., 1995e,f). In addition, it was shown that the insufficient recovery separating the

repetitive hiking bouts had a cumulative effect upon fatigue in quadriceps muscle groups. The development of muscle fatigue, which was mirrored in the progressive increase in the IEMG activity, is likely to have led, directly or indirectly, to the progressive tachycardia and hyperventilation. These changes in HR, ventilation and IEMG activity occurred in the absence of significant changes in [La].

At the completion of this investigation, the major practical aspect which appears to require further research is how to identify methods of delaying the development of fatigue in quadriceps, and possibly in other muscles, and therefore ultimately to improve hiking performance in sailing.

CHAPTER 5

5. LIMITATIONS ON AND TRAINING REGIMES TO IMPROVE HIKING PERFORMANCE

5.1 INTRODUCTION

The ultimate target for athletes, coaches and sport scientists is to maximise physical performance. As in other sports, the performance of the human operator in dinghy sailing can be maximised by the application of conditioning programmes which are designed to improve those physiological functions which limit sailing performance. A comprehensive understanding of the course of these functions during dinghy sailing is therefore necessary prior to the design and implementation of any conditioning programmes for dinghy sailors.

The combination of measurements carried out during actual and simulated sailing (described in Chapters 3 and 4) provided evidence of a strong association between the isometric nature of contraction of the anterior leg and trunk muscles of the sailors and the physiological requirements of hiking performance in dinghy sailing. More specifically, those experiments suggested a strong link between the development of muscular fatigue in the isometrically contracting quadriceps and the cardiorespiratory responses during hiking performance. It seemed therefore appropriate to investigate further the neuromuscular changes

and the incidence of fatigue in quadriceps and in other muscles. Furthermore, it was of interest to examine how the neuromuscular and cardiovascular responses could be modified following the implementation of different training regimes aimed at delaying fatigue and thereby maximising hiking performance.

In the study of localised muscular fatigue (the type of physiological fatigue which is induced by sustained muscular contraction and is associated with the inability to maintain a given force), analysis of the EMG signal detected on the surface of the skin over a muscle has been extensively employed. Since the historic work of Piper (1912), the main energy-carrying components of the EMG signal have been known to shift towards lower frequencies when a contraction is sustained. Gobb and Forbes (1923) noted this shift in frequencies toward the lower end with fatigue and also observed a consistent increase in the amplitude of the EMG signal recorded with surface electrodes. Several other investigators have also noted an increase in EMG signal amplitude when fatigue occurs (Kuroda et al., 1970; Lloyd 1971; Viitasalo and Komi 1977; Fallentin et al., 1993).

These two electrophysiological phenomena have also been reported during dinghy hiking to the point of exhaustion (Vogiatzis et al., 1993a), the amplitude increase being attributed to recruitment of additional motor units required to maintain the force exerted on the toe-strap when fatigue in quadriceps muscle

groups was developing. Since the application of EMG techniques offers a quantitative measure of the development of localised muscular fatigue, EMG measurements prior to and after the completion of training regimes for sailors could reveal changes in the motor unit recruitment pattern and therefore of the ability of the muscles to resist fatigue.

In addition investigation of improvements in hiking performance in terms of objectively-assessable neurophysiological and cardiovascular adaptations seems desirable by comparison with other published studies which quantified improvements in the physical condition of sailors after training in terms of parameters which could be affected by subject motivation. More specifically, improvements in hiking performance have been solely assessed by the difference in duration that the hiking effort was adequately maintained before and after the implementation of training regimes. Furthermore, training studies for sailors (Wright et al., 1976; Kent 1983; Spurway and Burns 1993) have lacked control of the amount of training administered to each individual during each session since subjects were not supervised during their training programmes and therefore adherence to training was questionable. Also formalistically it could be argued that those studies lacked assessment of the degree of benefit gained after training since performance was not compared with a control group which did not undertake any specific exercise. Clearly however the most recent training study (Spurway and Burns 1993) emphasised the superiority of hiking specific

exercises and therefore the training regimes which will be reported in this Chapter involve a great deal of hiking specific physical activities.

The purpose of this Chapter is two fold: firstly to examine the level of activation and the incidence of fatigue in a number of different muscle groups during hiking performance, and secondly to identify methods of delaying the development of muscle fatigue in those muscles which are more likely to fatigue due to the high degree to which they are activated during hiking exercise.

Studies performed were as follows:-

In study I, the level of activation of a number of muscle groups was investigated using EMG recordings during a hiking experiment on a stationary hiking bench.

In study II, the relative effectiveness of two different training regimes was investigated in terms of changes in the electrophysiological and cardiovascular responses during hiking exercise on a stationary hiking bench. Both regimes involved hiking-specific exercises on a hiking bench and aerobic training on a bicycle ergometer and on a treadmill. The main differences between the two regimes were associated with the intensity and the mode of exercise undertaken by subjects. One training programme involved low intensity exercise performed continuously for a given period of time (continuous exercise) and the other

programme involved periods of more intensive muscular activity followed by periods of rest (intermittent exercise).

5.2 METHODS

5.2.1 Subjects

Study I: Seventeen experienced sailors (fourteen male and three female), members of the Scottish National Squad and the Glasgow University Sailing Club, took part in this study. The mean (\pm SD) age, body mass and height of the subjects were as follows: 20.6 ± 3 years, 66.7 ± 10.1 kg and 176 ± 8 cm.

Study II: Eleven male and four female sailors (members of the Scottish National single-handed Sailing Squad and the Glasgow University Sailing Club) volunteered to participate in study II. Their mean (\pm SD) age, body mass and height were 21 ± 2 yrs, 70 ± 12 kg and 176 ± 6 cm, respectively.

5.2.2 Hiking bench

A stationary hiking bench was used to simulate hiking in the laboratory. The hiking bench, which was the same one used in the study by Spurway and Burns (1993), was constructed on a solid wood base frame. Towards one end there

were two upright side members providing bearing points for a padded seat. Near the opposite end a toe-strap was anchored to a cross-piece of the base-frame. The seat was adjustable for height and the toe-strap could be moved forwards or backwards to suit the dimensions of the subjects, effectively eliminating any inter-subject differences in the hiking posture adopted. The use of this stationary bench was considered necessary at this stage because body angles and the force exerted on the toe-strap could be accurately controlled at constant levels.

5.2.3 Control of the force exerted on the toe-strap

A load cell unit mounted at the rear part of the hiking bench was connected to the toe-strap at the opposite end of the bench. The digital display unit, which was connected to the load cell transducer, provided continuous feedback to the subjects by displaying the force exerted on the toe-strap and so assisting them to maintain the applied force throughout the hiking experiments.

5.2.4 Control of body angles

The degrees of displacement at the knee and hip joints (left lower limb) were measured using two Penny and Gyles M 110 twin axis electrogoniometers. The position of the goniometers was standardised for each subject by drawing lines

between certain anatomical points on their bodies. The anatomical points which were used to define the position of the goniometer at the knee joint were the following: lateral malleolus, head of tibia, and greater trochanter; whereas for the hip joint the anatomical points were the head of the tibia, the greater trochanter and the acromion process. Obviously this latter procedure could not guarantee that the same hip angle had been adopted by two subjects, if one hiked with a straight spine and the other with a flexed one. Two additional features, however, made this problem negligible in practice: (i) A light rope was extended transversely across the bench behind each subject's back, at shoulder-blade level, and they were instructed just to touch this. The effect was that no subject adopted a markedly flexed position. (ii) Use of the goniometer was confined to the re-establishment by any given subject in the post-training test of that subject's pre-training position. Differences of hiking style between individuals were thus of no concern.

Subjects were instructed to maintain constant angles at the hip and knee joints throughout each hiking experiment. For this purpose they received continuous feedback by watching the video monitor of a BBC computer programmed to display in degrees the angles of the joint displacement at the two recorded joints.

5.2.5 Recording the EMG activity

During study I, the EMG activity was recorded by pairs of skin electrodes with contact areas of 0.65 cm^2 , placed 15 mm apart in a line parallel to the muscle

axes of the following four muscles: rectus femoris, vastus lateralis, rectus abdominis and tibialis anterior. During study II, EMG recordings were made only on rectus femoris of the right leg. During both experiments, 4 seconds' worth of EMG data was collected every 20 seconds throughout each hiking test. The EMG signal was sampled by a computer programme running on a BBC Master computer and integrated (IEMG) for each 4 second period. The average IEMG activity recorded during each hiking test was expressed as a percentage of the maximum activity (% max. IEMG) recorded during the strongest of three brief maximal voluntary contractions (MVC) of that muscle group performed by the subject before the experiment.

For study II, similar electrode positioning before and after the 7-weeks of training was accomplished by measuring the distance between each pair of electrodes and the following anatomical points: greater trochanter, tibial tuberosity, lateral and medial condyles.

5.2.6 Cardiovascular measurements

In study II, HR was recorded throughout each hiking test at intervals of 15 sec using a PE 3000 Sports Tester monitor.

5.2.7 Experimental protocols

According to the test protocol of study I, subjects were asked to perform two separate hiking tests in a random order lasting 3 minutes each. During the

experiments EMG recordings were performed alternately on opposite sides of the body in a random order for each subject. Subjects had been instructed to maintain a constant exerted force on the toe-strap of the stationary hiking bench and to keep constant the angles at the knee and hip joints throughout each hiking test. Therefore, by recording the EMG activity when the hiking posture was maintained unchanged, it was possible with some confidence to attribute any changes in the EMG signals to the development of muscle fatigue and not to changes in body posture or in the forces exerted to the toe-strap.

In study II, subjects were randomly assigned to three groups (A, B, and control group C) of five subjects per group. Prior to and after the implementation of training regimes for groups A and B, all subjects were tested on the hiking bench. Subjects were instructed to maintain the hiking effort for a minimum duration of 3 min. After completion of the third minute, subjects were encouraged to maintain the hiking effort until volitional exhaustion. EMG and HR recordings were obtained only for the first 3 min during both pre and post-training tests and were averaged over 1 min intervals. The force exerted on the toe-strap and body angles were controlled at constant levels according to the procedures described earlier. The average force and angles of displacement on the hip and knee joints recorded from each subject during the pre-training test were accurately reproduced during the post-training test. To eliminate

differences in the pre-test HR values between the pre- and post-training tests a long period of rest was allowed before the start of each test.

5.2.8 Training regimes

The training programmes (Study II) were followed for a total of 7 weeks, and called for a minimum attendance of 3 sessions per week. During this period, the average attendance per week was 3.0 ± 0.5 days and the average time devoted per session was 45 ± 8 minutes. The programmes commenced with cycling on a bicycle ergometer for 12 min, followed by running on a treadmill for 12 minutes and terminated by hiking on the hiking bench for at least 20 minutes. The intensity of exercise on the bicycle and the treadmill was controlled using HR recordings and setting specific HR targets.

Subjects in group A exercised continuously on a bicycle ergometer (Monark) and on the treadmill (Quinton), accomplishing four different workloads. During exercise the workload increased every 3 min. During the first 3 weeks the target HR was established at approximately 60 % HR max (predicted maximal value for the age group). During weeks 4 and 5 the target HR was established at approximately 70 % HR max, whereas during the last two weeks the target HR was maintained at approximately 75 % HR max. Hiking exercise involved 10 to 12 repetitive hiking bouts each lasting for 2 min during the first three

weeks, 2.5 min during weeks 4 and 5 and 3 min during the last two weeks. Bouts were separated by 15 sec rest intervals.

Subjects in group B exercised intermittently on both the bicycle ergometer and the treadmill, accomplishing four different workloads. Exercise consisted of 1.5 min intense physical activity, followed by 1.5 min of rest. The workload was also increased every 3 min. During the first 3 weeks the target HR was established at approximately 75 % HR. During weeks 4 and 5 the target HR was set at approximately 80 % HR max whereas during the last two weeks the target HR was maintained at approximately 85 % HR max. Hiking exercise involved 15 to 20 repetitive hiking bouts each lasting for 1 min during the first three weeks, 1.5 min during weeks 4 and 5 and for 2 min during the last two weeks. During hiking exercise subjects were instructed to place a series of weights (ranging between 2 and 10 kg) on their abdomens so as to increase the difficulty of the hiking effort. Bouts were separated by 30 sec rest intervals.

Group C served as a control group without undertaking any of the prescribed specific exercise regimes.

5.2.9 Statistical analyses

Study I: One-way ANOVA, followed by Newman-Keuls follow-up test where appropriate, was used to determine if changes in the recorded physiological

variables were significant. Differences between means were estimated using t-tests for independent samples.

Study II: A two-way factorial ANOVA with repeated measures, followed by t-tests for paired or independent samples where appropriate, was used to determine if changes in the recorded physiological variables were significant.

For both experiments statistical significance was accepted at $P < 0.05$. All data are presented as means \pm (SD).

5.3 RESULTS

5.3.1 Study I

Rectus femoris and vastus lateralis were activated during bench-hiking at significantly higher percentages of their maximum strengths (approximately 30 % max IEMG) than rectus abdominis and anterior tibialis (approximately 15 % max IEMG). The average % max IEMG activities recorded over the 3-min periods from rectus femoris and vastus lateralis of the right and left legs were not significantly different (30.2 ± 5.1 % and 30.5 ± 3.5 % max IEMG versus 29.3 ± 4.1 % and 31.0 ± 4.5 % max IEMG, respectively) (Figure 15).

The average % max IEMG activity recorded from rectus femoris and vastus lateralis of the right leg during the 1st minute of hiking was 23.5 ± 2.1 % and 25.1 ± 3.0 %, respectively. The % max IEMG activity changed little during the 2nd minute to 26.4 ± 4.1 % and 27.6 ± 3.7 % for rectus femoris and vastus lateralis respectively. Thereafter, during the 3rd minute of hiking the % max IEMG activity of these muscles almost doubled to 40.7 ± 6.4 % and 39.1 ± 5.7 % respectively. The IEMG activity recorded every minute from rectus femoris and vastus lateralis of the left leg followed a very similar pattern of increase.

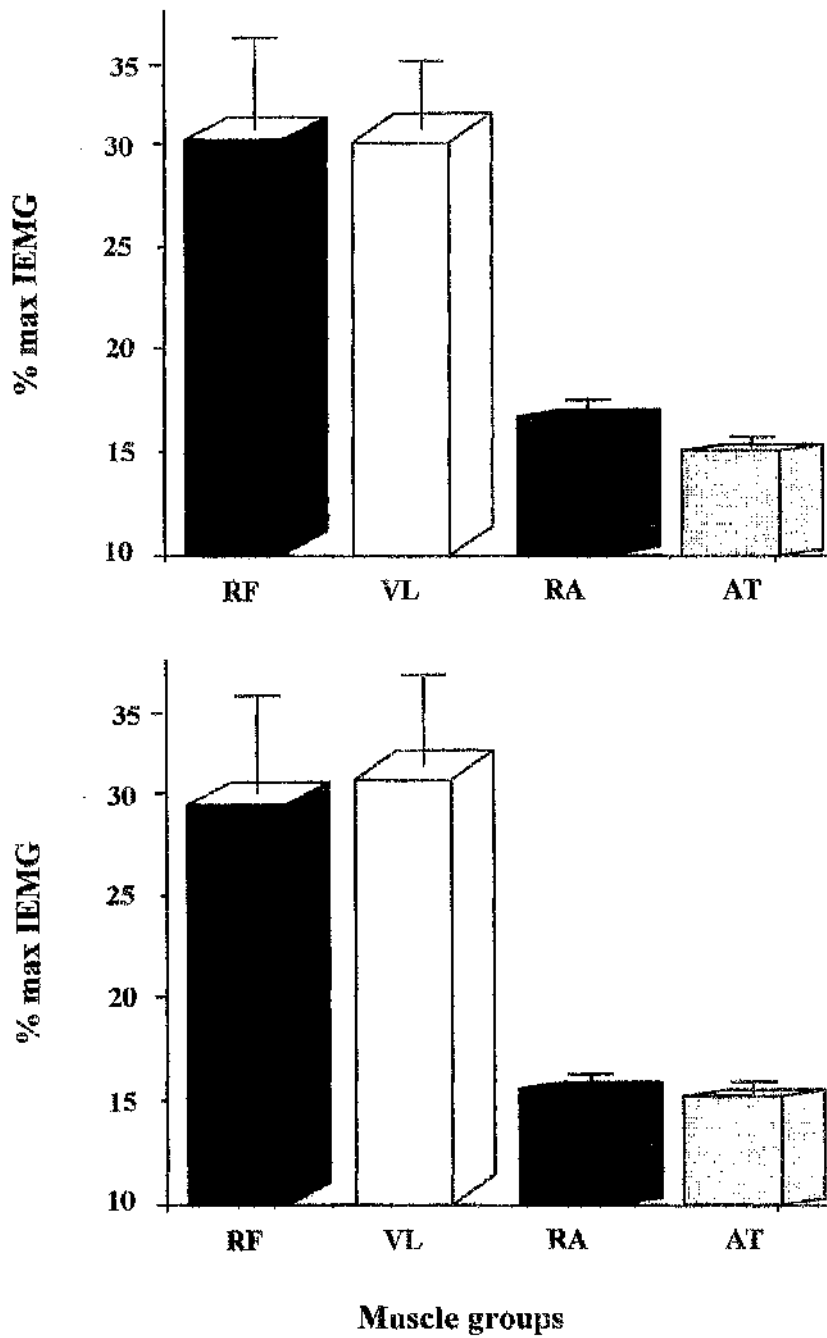

Fig. 15. Average level of activation in four muscle groups [rectus femoris (RF), vastus lateralis (VL), rectus abdomini (RA) and anterior tibialis (AT)] recorded from the right (top) and the left (bottom) sides of the body during hiking performance.

Rectus abdominis and anterior tibialis also did not exhibit significantly different levels of activation between the right and the left sides of the body (16.5 ± 1.6 % and 15.0 ± 0.9 % max IEMG versus 15.7 ± 1.0 % and 15.2 ± 1.1 % max IEMG, respectively), (Figure 15). Finally, no significant differences in the levels of activation between vastus lateralis and rectus femoris, and between rectus abdominis and anterior tibialis on the two sides of the body were observed.

5.3.2 Study II

Although at the end of the 7 week training regimes there was a tendency for lower % max IEMG activity recorded from rectus femoris in both A and B groups, statistical analysis revealed that those differences were not significant (Figure 16). Group C showed no signs of any changes in the % max EMG activity recorded from rectus femoris.

In addition, HR recordings during the post-training tests tended to be lower than those recorded during the pre-training tests in both A and B groups. However this difference fell short of statistical significance (Figure 17). HR recordings for Group C showed no signs of any changes between the two tests.

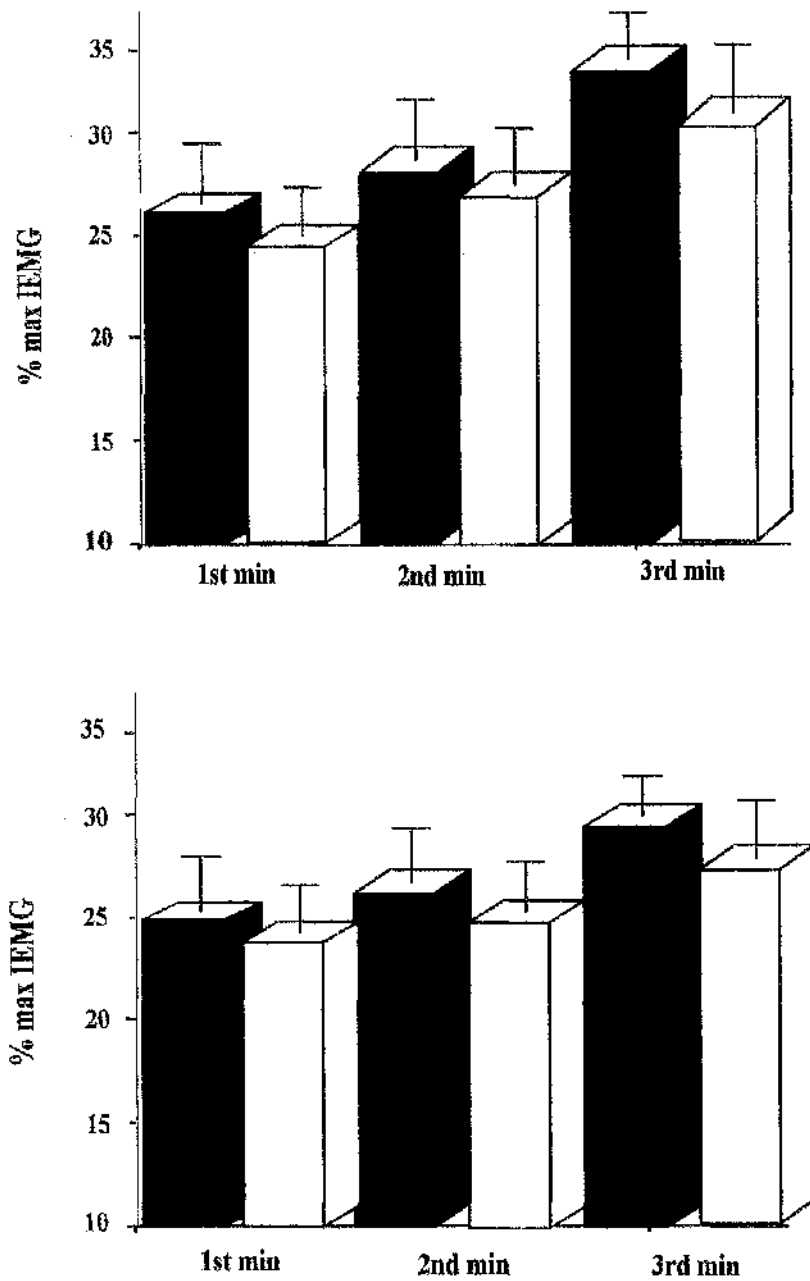

Fig. 16. The average % max IEMG activity recorded during each minute of hiking exercise from rectus femoris before (solid bars) and after (clear bars) the 7 weeks training programmes for groups A (top) and B (bottom).

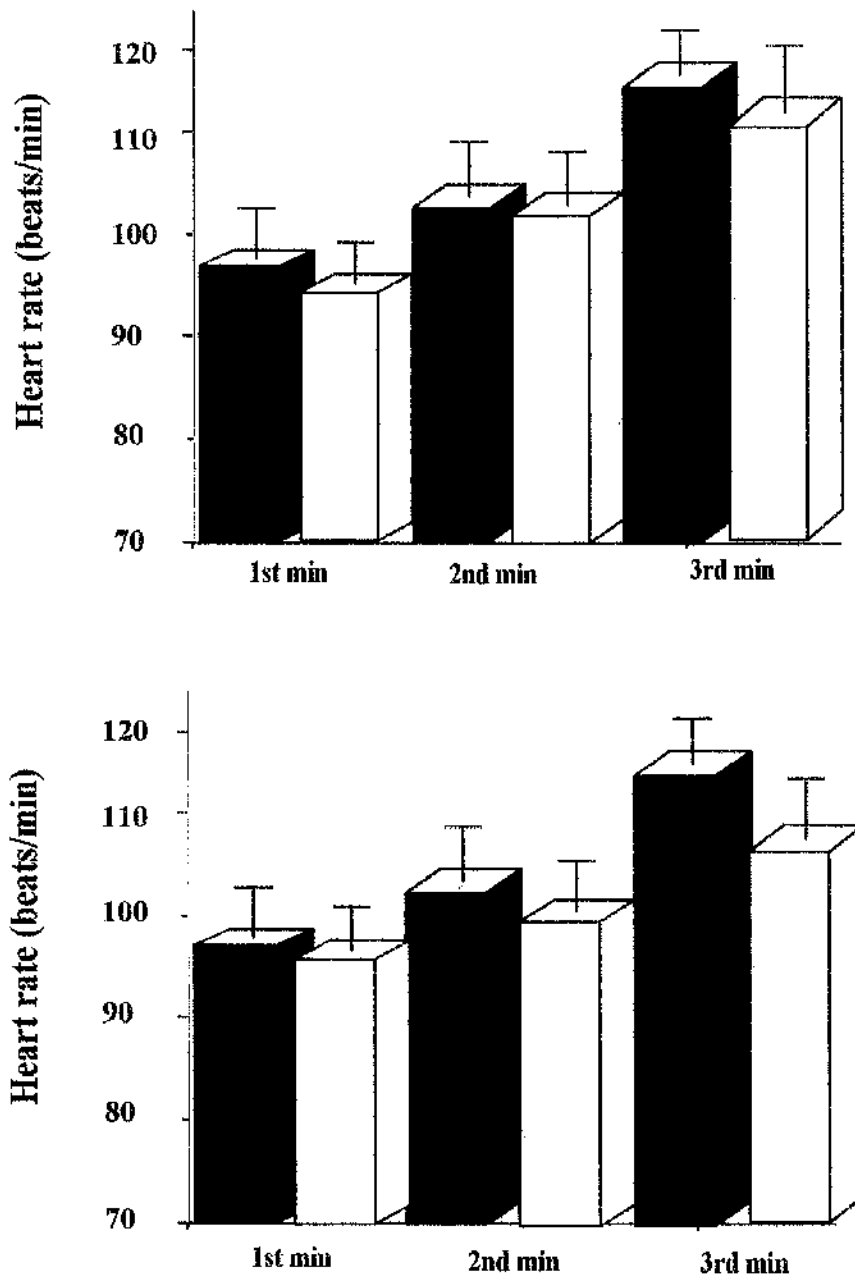

Fig. 17. The average HR responses recorded during each minute of hiking exercise before (solid bars) and after (clear bars) the 7 weeks training programmes for groups A (top) and B (bottom).

The only variable which was significantly different between pre and post-training tests was the time taken to exhaustion. The average pre-training hiking times for groups A and B were not significantly different (5.0 ± 1.0 and 5.5 ± 1.5 minutes, respectively). After the 7 week training programme the average hiking time for group A was 8.5 ± 2.5 minutes whereas for group B the hiking time was 7.2 ± 2.0 minutes. For group C, no difference in hiking time was observed between the first test (5.2 ± 1.2 minutes) and second test (4.5 ± 1.0 minutes).

5.4 DISCUSSION

5.4.1 Study I

The average level of activation recorded from rectus femoris and vastus lateralis for both legs (approximately 30 % max IEMG) is similar to that (31 ± 4 % max IEMG) recorded from rectus femoris during the first 3-min hiking bout of the simulation tests reported in Chapter 4. Therefore the quadriceps muscle groups in this study were activated to a degree similar to that recorded during the previous hiking simulation tests, so the present results confirm and expand on the earlier findings.

The fact that the force exerted on the toe-strap of the hiking bench and the angles at the hip and knee joints were kept constant, whereas the recorded IEMG activity from rectus femoris and vastus lateralis increased steadily during hiking, provides a strong indication that fatigue developed in those muscles (Moritani et al., 1986). As in the previous hiking simulation study, fatigue was probably caused chiefly by the impairment of the local blood flow in quadriceps muscle groups. Such an impairment might have occurred because the level of activation of quadriceps (which, even during the first minute of the hiking exercise, was in excess of 25 % max IEMG) raised the intramuscular pressure above the muscle's perfusion pressure (Edwards et al. 1972). The dramatic

increase in quadriceps IEMG activity, which occurred during the last minute of contraction, demonstrates additional motor unit recruitment and tallies with the observation of other investigators (Petrofsky and Lind 1980; Basmajian and De Luca 1985) who documented that during fatigue the amplitude of the EMG signal shows the most pronounced increase near the end of the contraction.

On the other hand, although the average level of activation in abdominal and tibialis muscle groups (approximately 15 %) was within the range of tension which is known to diminish blood flow through most muscles (Sjogaard et al., 1986) the time that the hiking exercise lasted was somewhat shorter than that for which it was typically possible to maintain force at these rather low activation levels.

It seems therefore reasonable to believe that hiking performance in the present study would be limited mainly by the development of muscular fatigue in quadriceps muscle groups. This is the reason why EMG recordings in study II were taken just from a representative muscle of the quadriceps groups. Since, all the subjects who participated in study II had previously participated in study I, study I served as a familiarisation trial for all subjects who took part in the later work.

5.4.2 Study II

In this study it was accepted from the foregoing that the development of fatigue in quadriceps was principally responsible for limiting hiking performance and that an improvement in the strength characteristics of these muscle groups would improve performance. It was also hypothesised that an increase in the maximum strength of quadriceps would allow subjects to maintain the hiking posture at a lower percentage of these muscle's maximum strength, thus generating a lower intramuscular pressure and allowing a more adequate blood supply. Since a strong association between the intramuscular pressure, the IEMG activity and the cardiovascular responses has been reported during isometric exercise (Schibye et al., 1981) any improvements in quadriceps' strength characteristics would be reflected in lower % max IEMG activity and HR responses during the post-training hiking tests.

The results of the present study showed that the % max IEMG activity and HR responses recorded throughout the post-training hiking tests tended to be lower than those obtained during the pre-training tests for both groups A and B. Although, these reductions fell short of statistical significance, no such trend was evident for the control group.

The lack of substantial improvements in the neuromuscular and cardiovascular responses after training may be due to the nature of the applied regimes since in both training programmes a large component of the training duration (approximately 50 %) was devoted to aerobic conditioning. Aerobic training has been shown to increase the volume of oxygen offered to the skeletal muscle (Saltin et al., 1985), the oxidative enzyme activity (Newsholm and Leech 1983), the capillary density, the mitochondrial volume, the local arteriovenous oxygen difference and the maximal flow rate of the muscles (Saltin and Golnick 1983). These benefits are known to improve aerobic performance during which the blood flow through the working muscles is greatly facilitated by the capillary dilatation and the pumping action of the working muscles. Hiking performance might have also been improved by the above mentioned adaptations only if a substantially lower intramuscular pressure allowed a more adequate local blood supply. However, the fact that the % max IEMG activity and the HR responses did not change significantly after training suggests that the intramuscular pressure did not change significantly either after training (c.f. Schibye et al., 1981; Sjogaard et al., 1986).

An additional factor contributing to the lack of statistical significance could be the small number of subjects available to be assigned to the two groups.

In the literature (Thorstensson et al., 1976), similar findings suggesting a lower % max IEMG activity without reaching significant differences after training have failed to provide adequate explanation as to the mechanisms behind the well established gains in muscle strength resulting from the applied strength training programmes. Changes may occur in the recruitment pattern of individual motor units or improvements in the co-ordination of these units may vary as pointed out by Komi and Buskirk (1972), and the 7 weeks training period used in the present study might have been too short to obtain conclusive results.

The claim that the training regimes improved hiking performance is thus based upon the fact that subjects in both groups A and B maintained the hiking posture for a significantly longer time after training than before, whereas no improvement in the hiking duration was observed for the control group. So the ultimate target of the training regimes for both groups A and B was achieved; the hiking posture was maintained for a longer period of time after training and thus the applied conditioning programmes significantly improved hiking performance.

The results of the present study suggested that the hiking performance for group A showed a trend to be better than group B

which undertook the intermittent training programme. The reason for such a difference is not clear but it is noteworthy that the trend is the same direction as that discussed by Spurway and Burns (1993). As to the mechanisms, it can be speculated that continuous rather than intermittent hiking might have had either or both of two effects:

- (i) improved the physical tolerance of the quadriceps to isometric effort,
- (ii) inured the subjects to the discomfort associated with this form of effort.

In conclusion the present studies confirmed the results of other investigations (Piehl-Aulin et al., 1977; Marchetti et al., 1980) that quadriceps muscle groups exhibit the most pronounced activity of all muscles recruited during hiking exercise. Due to the high degree to which these muscles are activated it seems reasonable to believe that the development of fatigue in quadriceps is most likely to limit hiking performance. In addition, it has been shown that hiking endurance can be prolonged by the implementation of training regimes aimed at improving the strength characteristics of quadriceps muscle groups. Although an improvement of hiking performance was achieved after training, the present findings offer no conclusive evidence of the mechanisms responsible for resisting muscle fatigue and thus maximising hiking performance.

CHAPTER 6

6. GENERAL DISCUSSION

In 1967, Durnin and Passmore reported that they knew of no-one who had measured the energy cost of any of the many different activities in which a sailor is employed. They added that "most sailors probably find that their recreation provides them with exercise of light grade, but with occasional periods of moderate or heavy exercise".

Since those days, a considerable number of scientific papers have indicated that, although sailing places unusual demands upon the sailors' bodies, the medico-physiological aspects of this sport require special study when maximisation of sailing performance is to be achieved. Increasing interest in the performance of the human operator in sailing was strongly reflected by the organisation of the first Sailing Sports Medicine Symposium (October 1992, Italy) during which 24 scientists from various European countries presented papers on the biological aspects of sailing. Twenty five years after the statement by Durnin and Passmore, scientists in that Symposium communicated data not only about methods for assessing the energy cost of sailing or the physical demands of this sport, but also about scientific topics such as dietary and psychological preparation, methods for detecting the incidence of musculoskeletal injuries, and drugs likely to be used by sailors. Today, investigation into the physical

demands of sailing is so widespread that scientists from all corners of the world conduct scientific work on how to improve sailing performance.

In support of the need for increased scientific information relating to the sport of sailing, the series of studies presented in this thesis were aimed at investigating, in greater detail, the physiological demands of the major physical challenge of dinghy sailing: the *hiking* effort. The ultimate target of these studies focused on the identification of the factors which could limit hiking performance and it is hoped that the recommended training strategies suggested by these studies may maximise sailing performance.

To identify the limiting factors of any kind of physical activity, many parameters must be considered. Among these are parameters associated with the percentage contribution of the various energy delivery systems during athletic performance, which in turn depend on the intensity, the duration, the mode *and the form* of exercise.

A special feature of hiking in dinghy sailing which makes it a different kind of physical exercise from that involved in almost every other sporting activity, is that it requires from the quadriceps, the abdominal and the lower leg muscles, isometric contraction for periods of many minutes with only a few brief intervals of relief. In the dynamic forms of exercise more commonly involved in sport,

e.g. running, cycling, swimming, and rowing, each group of muscles alternately contracts and relaxes, often more than once a second; and it is during the periods of *relaxation* that the main muscle blood flow occurs. In contrast, during isometric contractions there is no such opportunity because the blood flow through the working muscles is impaired by the high intramuscular pressures. Since isometric contractions hinder the local blood flow while the overall effect of dynamic exercise is to facilitate the circulation, it follows that a greater $\dot{V}O_2$ can be obtained during dynamic exercise (Astrand and Rodahl 1986). If the latter type of activity has to be maintained for periods of several minutes, the higher the $\dot{V}O_2$ which can be sustained by an individual for prolonged periods, the better his/her performance will be in dynamic exercise. A high $\dot{V}O_2$ is usually achieved by having a high maximal $\dot{V}O_2$, and/or by the ability to exercise at a high proportion of the maximal $\dot{V}O_2$ for the duration of the athletic event (Maughan 1990). It is therefore expected that the maximal aerobic power will be the principal limiting factor in that type of athletic performance. In other words the central circulation and the capillary bed available for perfusion - which determine the volume of oxygen offered to the skeletal muscles - are considered to be the limiting factors of performance in dynamic events which last for several minutes (Saltin and Gollnick 1983).

Although hiking in dinghy sailing has often also to be maintained for several minutes between tacks, it seems highly unlikely that hiking performance could be limited by the amount of oxygen offered to the contracting muscles by the central cardio-respiratory system because these muscles are partially or completely blocked from the central circulation. Support of this suggestion is provided by the average figures of the percentage of the maximal $\dot{V}O_2$ required during actual sailing conditions. The fact that those figures ranged between 37 and 42 percent of the maximal $\dot{V}O_2$ strongly indicate that aerobic power is only moderately taxed in dinghy sailing and therefore cannot limit hiking performance (Vogiatzis et al., 1995a,b,c). In sports activities where maximal $\dot{V}O_2$ is indeed the limiting factor for performance (e.g. cycling, running, swimming, rowing), the figures recorded during competition range typically between 75 and 90 percent of the maximal $\dot{V}O_2$. In addition the maximal $\dot{V}O_2$ values commonly recorded from those athletes vary between 70 and 80 ml kg⁻¹ min⁻¹. Therefore further support for the suggestion that aerobic power is not of great importance to the sailor can be deduced from the very moderate maximal $\dot{V}O_2$ values (52 ± 6 ml kg⁻¹ min⁻¹) recorded from the sailors who participated in the present studies (Vogiatzis et al., 1995a,b). If the sport of dinghy sailing placed particularly high demands upon the oxygen transport system, high $\dot{V}O_2$ capacities would have been required for successful competition - and the subjects studied were all very successful sailors.

The measurements performed during actual and simulated hiking also revealed that the cardiovascular system and respiratory *drive* were challenged relatively more than the oxygen transport system. The tachycardia, high blood pressure and hyperventilation seen during hiking performance are features typical of those reported using other forms of isometric exercises maintained for periods of many seconds or minutes (Assmusen 1965; Lind and McNicol 1967). During real hiking, of course, the muscles may not be entirely static, as in laboratory studies involving strictly isometric contractions, but for extended periods of time they still have no opportunity to relax. Lack of relaxation of these muscles would massively diminish the amount of oxygenated blood nourishing them and would quite rapidly lead to the development of muscle fatigue. As individual muscle fibres or motor units fatigue, recruitment of new units will demand an expansion of the central motor command. If the central command is accompanied by an 'irradiation of impulses' (Krogh and Lindhard 1913) to cardiovascular and respiratory centres, the continuous increase in HR, MABP and \dot{V}_E may be understood (Assmusen 1981; Schibye et al., 1981). Furthermore the increased feeling of exertion (RPE) expressed by the subjects as the simulated hiking experiments proceeded indicates an increased central nervous excitatory state. On the other hand the possibility that metabolic changes in the fatiguing muscles may activate the small type III and type IV fibres, causing an increased reflex stimulation of the cardiovascular and respiratory centres cannot be excluded (McCloskey and Mitchell 1972; Mitchell et al., 1981), though arguments

suggesting that they are not predominant influences were offered earlier in Chapter 4. Nevertheless, whatever the source of stimulus (central and/or peripheral) which elicited tachycardia and hyperventilation during hiking, the main cause for such responses proved to be the development of the *local muscle fatigue* which without doubt is what chiefly limits the muscular performance (Vogiatzis et al., 1995b,d,e).

One of the most striking features of both the simulations and the on-water tests was the absence of a marked increase in blood lactate concentration. The average peak blood lactate concentration three minutes after the end of the last hiking bout (2.8 ± 0.9 mM) and that three minutes after the end of the on-water tests in strong winds (3.0 ± 0.6 mM) were not large enough to imply a high degree of anaerobic contribution to metabolism. The lack of a larger increase in the blood lactate concentration may be explained in two ways: firstly that only a small muscle mass (the quadriceps) relative to the subject's total muscle mass was activated at a high percentage of its MVC, and perhaps secondly that lactate produced in those *vigorously working muscles* could be carried away by the circulation during the less intense phases of hiking (decrease in wind velocity, reductions of the heeling moment, or during tacking when blood flow through the muscles is momentarily restored) and metabolised in other muscles without being detected by the limited number of blood samples taken. The fact that biceps muscle groups were activated at about 25 % of *their maximum force*,

suggests that a large number of muscles on the upper body (recruited to stabilise the position of the upper limb, or even activated dynamically when steering or working the mainsheet) were engaged during hiking and may be utilising lactate as a substrate for their metabolism. Assuming that quadriceps muscle groups might have been accounted for production of most of the lactate which appeared in the capillary blood (2.8 - 3.0 mM), a considerably higher amount of lactate produced in those muscles should be also expected. Such a suggestion has been confirmed during single lower limb isometric contractions where the lactate concentration in vastus lateralis and in the femoral vein were by 3 to 4-fold and by 2 to 3-fold respectively higher than in the arterial blood (Saltin et al., 1981). Therefore the possibility that the production of lactic acid in the isometrically contracting quadriceps might have diminished the muscle pH thus causing fatigue cannot be excluded on the basis that the blood lactate concentration observed after hiking was only moderate (Vogiatzis et al., 1995f).

Further support for the suggestion that accumulation of lactic acid, trapped within the muscle interstitial fluid during the isometric contraction, might have limited the muscle's performance is provided by the electromyographic recordings made on those muscles. As noted previously the average level of activation of quadriceps muscle groups (which was in excess of 25 % of their maximum activation even during the first minute of hiking exercise) was within the range of muscle tension where the intramuscular pressure exceeds the

muscle's perfusion pressure (Edwards et al., 1972). Under these conditions oxygen supply to the working muscles becomes insufficient which in turn results in peak accumulation rates of lactic acid (Ahlborg et al., 1972; Karlsson et al., 1975; Cerretelli et al., 1976). Lactic acid virtually completely dissociates and hydrogen ions (H^+) are formed in an amount equivalent to lactate (Sahlin 1986). H^+ accumulation may impair muscle performance through its effect on glycolysis, on the contractile process itself, or on certain physiologically important equilibrium reactions (Hultman et al., 1985).

Furthermore, the continuous increase observed in the amplitude of the EMG activity recorded from the quadriceps during all hiking experiments strongly indicates the occurrence of fatigue in those muscles. Although the available data cannot signify if the changes in the EMG activity of the contracting muscles was due to the recruitment of additional motor units (Fallentin et al., 1993), or due to the synchronisation of the already recruited motor units (Bigland-Richie et al., 1981), or even due to changes in the conduction velocity of the muscle fibres (Krogh-Lund and Jorgensen 1993), the increase in the amplitude of the EMG signal itself would indicate that the development of muscular fatigue is the major limiting factor during hiking performance (Vogiatzis et al., 1995d).

The pain and the sensation of the high intramuscular pressure originating in the isometrically contracting quadriceps would in turn be responsible for forcing the

relaxation of the hiking effort by sailors. This is supported by the high rates of perceived exertion recorded from the sailors during the hiking simulation tests. The RPE values ranged between 11 and 16 units thus indicating that sailors perceived that the hiking bouts felt somewhat taxing at the beginning of the test, and very strenuous close to the end of the tests. It is therefore possible that, under actual sailing conditions, a reduced level of tolerance of the feeling of discomfort would limit hiking performance before the development of muscle fatigue considerably decreases the ability of the muscles to generate a given force (Vogiatzis et al., 1995b).

There is strong evidence that sailors were able to prolong the duration that hiking could be sustained as a result of an increase in the strength of their muscles. This adaptation allowed them to sustain the hiking posture at a lower percentage of the muscle's maximum strength thus generating lower intramuscular pressures and retaining a more adequate blood supply. The tendencies for lower % max. IEMG activity while maintaining the same force on the toe-strap suggests that an increase in the maximal IEMG activity had occurred after training. Previous studies (Thorstensson et al., 1976; Moritani and DeVries 1978) have also shown that the increase seen in the maximum strength of a muscle after training is associated with an increase in the maximal IEMG activity, which in turn is compatible with either more efficient activation of the motor neurone pool or an increase of the size of muscle fibres.

In addition, hiking specific exercises are expected to improve the ability of the sailors to cope with the feeling of discomfort and pain. The fact that after the completion of the 7-week training programmes the sailor's time to exhaustion was significantly longer than that before training, in the absence of any significant changes in the electromyographic and cardiovascular responses, might suggest that sailors were able to cope for longer with the feeling of discomfort by increasing the level of their tolerance during hiking.

6.1 CONCLUSIONS

The results of the studies presented in this thesis indicate clearly that it is the degree of *isometric* effort, required to counterbalance a dinghy in different wind speeds, which principally determines the physiological requirements. In keeping with this, even under the most physically strenuous conditions, dinghy sailing does not require a high aerobic capacity. On the other hand anaerobic metabolism, which becomes detectable in moderate winds, could possibly limit hiking performance in stronger winds by the accumulation of its products. What does also seem to limit hiking performance is the high intramuscular pressure of the thigh muscles which impairs the blood flow and generates a feeling of discomfort and weakness during hiking. This feeling may be sufficiently explained by the degree of anoxia which presumably develops in the

flow-occluded regions, but trapping of both K^+ and the products of anaerobic metabolism (including H^+) in the muscle extracellular space could well augment the problem. It is the development of discomfort and weakness in the specific hiking muscles that sailors must overcome in order to prolong the hiking effort. Hiking performance will not in any way be negatively affected by an increase in the amount of oxygenated blood delivered by the cardiac muscle, but it will definitely be limited if blood flow does not find its way through the compressed blood vessels in the contracted muscles. Therefore, it is not appropriate that aerobic training should be emphasised (as currently recommended) since the oxygen transport system clearly does not limit performance. Of course this does not suggest that sailors should totally ignore aerobic training since this promotes general fitness which is necessary for any serious athlete who wishes to continue his or her sport-specific training on a regular base. However, aerobic training should be a base only and in no way should it be countenanced as the major emphasis in fitness programmes for dinghy sailors.

What can limit hiking performance and therefore should be emphasised in training, is the *local static endurance of the thigh muscles and to a lesser extent the abdominals.*

This was proved to be the case by the electromyographic, ventilatory, cardiovascular and metabolic measurements employed in this study which confirmed and extended earlier findings (Spurway and Burns 1993; Vogiatzis et

al., 1993a). The present studies using top level sailors clearly suggest that what distinguishes a good, fit sailor from one of lesser ability is the fact that blood flow in the legs of the good sailor is more readily maintained.

Finally, the unique combination of cardiac, respiratory and metabolic measurements, all acquired simultaneously under actual sailing conditions, and strongly supported by realistic laboratory simulations, were the special features of this thesis. At all points of overlap with previous studies (Spurway and Burns 1993; Vogiatzis et al., 1993a), the new results tally with the old; but the extensions bring us substantially closer to a full understanding of hiking physiology and so place the recommendations which follow on a substantially firmer base.

6.2 IMPLICATIONS FOR COACHES AND SAILORS

The findings of this thesis make it abundantly evident that training regimes for dinghy sailors should involve only a limited amount of aerobic activity. Alongside this there should be an extensive programme of hiking-specific exercises to help the sailor tolerate the muscular and circulatory strain imposed by the sustained isometric effort. It seems likely that such a benefit can be achieved in three ways:-

a) by increasing the maximum strength of the thigh and (to a lesser extent) the abdominal muscles, thereby enabling the hiking posture to be maintained at a lower percentage of the muscles' maximum strength. This will result in lower intramuscular pressures and correspondingly a more adequate supply of blood to the working muscles. Sufficient blood supply in relation to the metabolic needs will certainly prolong the hiking time.

b) by increasing the isometric endurance of the same muscles. Very little certain knowledge exists, either about how to train for this or what muscle property training alters. However, every other known challenge to muscle is best met by specific 'overload' of the challenge type, so it would be extraordinary if isometric endurance were not best enhanced by sustaining isometric exercises as long as possible (a conclusion entirely in keeping with the findings of Spurway and Burns 1993). As to what happens within muscle fibres, when their isometric endurance increases, one might speculate that:

- i) creatine (and hence CP) is increased, slightly postponing the need for ATP synthesis,
 - ii) myoglobin is increased, enhancing the period for which ATP can be resynthesized aerobically,
 - iii) intramuscular buffers (e.g. carnosine) and transmembrane proton pumps, retain the rate at which pH falls.
- c) possibly also by increasing the level of tolerance to discomfort and pain.

Maximum strength [(a) above] can be increased by weight resistance training, preferably in a gymnasium. The key to this type of training is to apply a few repetitions at near maximum weight capability. Maximum strength could also be improved by use of the dinghy sailor's traditional training aid, the 'hiking bench'. The technique would simply be to apply a few seconds of maximum static effort on the toe-strap while sitting and holding on the bench immediately before each hiking endurance session.

Local isometric endurance training of the thigh and abdominal muscles should be performed at the body angles applicable to hiking. This will maximise the muscles' capabilities at their appropriate lengths. The hiking bench (of dimensions similar to those of the deck and cockpit of the relevant dinghy), is the best aid for this. Care in adopting the correct posture on a hiking bench will also ensure that the intensity of the hiking exercise is similar to the physical efforts experienced during sailing. In both cases, posture must be one which minimises risk of chronic injury - knee slightly bent, hip angle submaximal, spine somewhat flexed. The mode of the exercise should mimic the handling procedures of sailing. One aspect of this is that training should involve hiking sessions of varying duration interrupted by brief intervals (to simulate tacking). Pulling frequently on an elastic-loaded rope rigged to simulate a mainsheet will also improve the upper body's capacity for successful steering and sheeting. It is very important however to emphasise that, while hiking, the trunk should not

be static; to be so is both boring and inappropriate. The sailor should continuously simulate on the bench all the body motions made when racing a dinghy in a big sea, swinging his/her trunk 'fore and aft' and 'in and out', and twisting alternately to left and right.

It is not suggested that aerobic exercise should be totally omitted. A certain amount of this form of exercise will definitely increase the work efficiency of the cardiac muscle and at the same time improve the ability of the limb muscles to utilise the available oxygen provided by the greater blood supply resulting from lower intramuscular pressure. Cycling and rope pulling are particularly recommended as these exercises utilise a number of the muscles used in sailing and simultaneously improve both cardiovascular and muscular fitness.

The main concern in the studies presented in this thesis has been with hiking, since this makes an immense contribution to race-winning in moderate or strong winds and is the most physically demanding activity experienced by most dinghy sailors who do not trapeze. A complete fitness programme however will also give attention to flexibility, to upper body strength, and where necessary to body weight.

6.3 DIRECTIONS FOR FURTHER RESEARCH IN THE AREA OF DINGHY SAILING PHYSIOLOGY

In the context of the present thesis the limitations of hiking performance were identified under the spectrum of the short term fatigue occurring mainly in the quadriceps muscle groups during rapidly successive hiking bouts or during individual bouts of hiking performance. However, sailing events, and therefore the requirements for hiking performance, may last for many hours every day and for many days during a sailing regatta. This highlights the need for an investigation into the factors which can cause long term limitations of hiking performance. Such factors could be associated with:-

- a) the content of the muscles' glycogen stores during repetitive races held on one day.
- b) the sufficiency of glycogen store repletion after a racing day or during the period that a regatta lasts.
- c) dehydration and sufficient rehydration when sailing events are performed in a warm environment
- d) the levels of blood glucose which could diminish the efficiency of the cerebral function, thus affecting adversely the tactical decisions during a race.

All these factors point out the need for further research about the appropriate dietary preparation and liquid supplementation for sailors.

In addition, there is a need for further research into the nature of the sailing specific training regimes prescribed for sailors. It is true that the best way to train to improve hiking performance is to actually sail in a strong wind. When this is not possible on a regular basis, then hiking exercises are the most appropriate conditioning methods for maximising sailing performance. However, this type of exercise is boring and difficult to sustain for extensive periods of time especially if it is made entirely static. Therefore alternative ways of improving hiking performance and analysing what is happening need in the future to be thoroughly investigated and developed.

REFERENCES

- Agnevic G. Wallstrom B. Saltin B. (1969). A physiological analysis of alpine skiing. *Idrottsfysiologi*, rapport no 7, Trygg-Hanna, Stockholm.
- Ahlborg B. Bergstrom J. Ekelund LG. Guarnieri G. Harris RC. Hultman E. Nordesjo LO. (1972). Muscle metabolism during isometric exercise performed at constant force. *J Appl Physiol* **33**: 224-228.
- Assmussen E. (1965). Muscular Exercise. *Handbook of Physiology*, section 3. *Respiration* **3**: 939-978.
- Assmussen E. (1981). Similarities and dissimilarities between static and dynamic exercise. *Circ Res* **48**(6): I.3 - I.10.
- Astrand P-O. Rodahl K. (1986). *Textbook of Work Physiology*. Third edition: McGraw-Hill International Editions.
- Bachemont F. Fouillot J. Izou M. Terkaia M. Drobzowski T. (1981). Etude de la frequence cardiaque en deriveur et planche a voile par monitoring ambulatoire. *Union Medicale du Canada* **113**: 644-647.
- Ballal M A. MacDonald I A. (1982). An evaluation of the Oxylog as a portable device with which to measure oxygen consumption. *Clin Phys Physiol Meas* **3**:57-65.

- Barcroft H. Greenwood B. Whelan RF. (1963). Blood flow and venous oxygen saturation during sustained contraction of the forearm muscles. *J Physiol* **168**: 848-856.
- Basmajian JV. De Luca CJ. (1985). In: *Muscles Alive*, V (ed. Butler J.), Williams and Wilkins Company, Baltimore; Chap 8, p 201.
- Bigland-Richie B. Donovan EF. Roussos CS. (1981). Conduction velocity and EMG power spectrum changes in fatigue of sustained maximal efforts. *J Appl Physiol* **51**: 1300-1305.
- Bigland-Ritchie B. Dawson NJ. Johanson RS. Lippold OCJ. (1986). Reflex origin of the slowing of motoneurone firing rates in fatigue of human voluntary contractions. *J Physiol* **379**: 451-459.
- Blackburn M. (1994). Physiological responses to 90 minutes of simulated dinghy sailing. *J Sports Sci* **12**: 383-390.
- Borg GAV. (1982). Psychophysical base of perceived exertion. *Med Sci Sports Exerc* **14**: 377.
- Burstyn P. Coleman S. Hale T. Harrison H. (1988). Laboratory simulation of the physical demands of single-handed dinghy racing. *J Physiol* **400**: 14P.
- Cerretelli P. Veicsteinas A. Fumagalli M. Dell'Orto L. (1976). Energetics of isometric exercise in man. *J Appl Physiol* **41**: 136-141.

- Concu A. Marcello C. Rocchitta A. Ciutu C. Esposito A. (1992).
Telemetric measurement of heart-rate-matched oxygen consumption during
volleyball games. *Med Sci Res* **20**: 243-245.
- Goob S. Forbes A. (1923). Electromyographic studies of muscle fatigue in
man. *Am J Physiol* **65**: 234-251.
- Dal Monte A. Faina M. Leonardi M. Todaro A. Guidi G. Petrelli G. (1989).
Maximum oxygen consumption by telemetry. Translation from Sports
Science Culture Reviews; Scuola Della Sport, Sport School of CONI,
Italian Olympic Committee **15**: 3-12.
- De Vito G. Di Filippo L. Felici F. Marchetti M. (1993). Hiking mechanisms
in Laser athletes. *Med Sci Res* **21**: 859-860.
- Duncan G. Johnson RH. Lambie DG. (1981). Role of sensory nerves in the
cardiovascular and respiratory changes with isometric forearm exercise in
man. *Clin Sci* **60**: 145-155.
- Durnin JVGA. Passmore R. (1967). *Energy, work and Leisure*. William
Heinemann, Ltd., London.
- Edwards RG. Lippold OCJ. (1956). The relation between force and
integrated electrical activity in fatigued muscle. *J Physiol* **132**: 677-681.
- Edwards RHT. Hill DK. MacDonnel M. (1972). Myothermal and
intramuscular pressure measurements during contractions of the human
quadriceps muscle. *J Physiol* **224**: 58-59.

- Faina M. Gallozzi C. Marini C. Colli R. Fanton F. (1989). Energy cost of several sport disciplines by miniaturised telemetric oxygen uptake measurement. *In: Proceedings of the First IOC World Congress on Sport Science; October 28th - November 3rd, Colorado, USA.*
- Fallentin N. Jorgensen K. Simonsen EB. (1993). Motor unit recruitment during prolonged isometric contractions. *Eur J Appl Physiol* 67: 335-341.
- Funderbunk CF. Hipskind SG. Welton RC. Lind A. (1974). Development of and recovery from fatigue induced by static effort at various tensions. *J Appl Physiol* 37: 392-396.
- Gallozzi C. Fanton F. De Angelis M. Dal Monte A. (1993). The energetic cost of sailing. *Med Sci Res* 21: 851-853.
- Goodwin GM. McCloskey DI. Mitchell JH. (1972). Cardiovascular and respiratory responses to changes in central command during isometric exercise at constant muscle tension. *J Physiol* 226: 173-190
- Harrison J. Coleman S. (1987). The physiological strain of racing a small, single-handed dinghy. *J Sports Sci* 5: 79-80.
- Harrison J. Bursztyn P. Coleman S. Hale T. (1988). A comparison of heart rate, oxygen uptake relationship for cycle and dinghy ergometry. *J Sports Sci* 6: 160.

- Hnic P. Vyskocil F. Ujec E. Vejsada R. (1986). Work-induced potassium loss from skeletal muscles and its physiological implications. In: *Biochemistry of Exercise, VI* (ed. Saltin B) Champaign, IL., Human Kinetics, pp 345-364.
- Hultman E. Del Canale S. Sjöholm S. (1985). Effect of induced metabolic acidosis on intracellular pH, buffer capacity and contraction force of human skeletal muscle. *Clin Sci* **69**: 505-510.
- Inns F. Mehta D. (1989). Respiratory responses to sustained isometric muscle contractions in man: the effect of muscle mass. *J Physiol* **419**:1-14.
- Karlsson J. Funderburk CF. Essen B. Lind LA. (1975). Constituents of human muscle in isometric fatigue. *J Appl Physiol* **38**: 208-211.
- Kawakami Y. Nozaki D. Matsuo A. Fukunaga T. (1992). Reliability of measurement of oxygen uptake by a portable telemetric system. *Eur J Appl Physiol* **65**: 409-414.
- Kent J. (1983). Winning in one-designs; getting in shape for hiking. *Yacht racing*: March 75-77.
- Kiblom A. Person J. (1982). Leg blood flow during static exercise. *Eur J Appl Physiol* **48**: 367-377.
- Komi PV. Burskin ER. (1972). Effect of eccentric and concentric muscle conditioning on tension and electrical activity of human muscle. *Ergonomics* **15**:417-434.

- Komi PV. Viitasalo JHT. (1976). Signal characteristics of EMG at different levels of muscle tension. *Acta Physiol Scand* **96**: 267-276.
- Krogh A. Lindhard J. (1913). The regulation of respiration and circulation during the initial stages of muscular work. *J Physiol* **51**: 59-90.
- Krogh-Lund C. Jorgensen K. (1993). Myo-electric fatigue manifestations revised: power spectrum, conduction velocity, and amplitude of human elbow flexor muscles during isolated and repetitive endurance contractions at 30 % maximal voluntary contraction. *Eur J Appl Physiol* **66**: 161-173.
- Kuroda E. Klissouras V. Mulsum JH. (1970). Electrical and metabolic activities and fatigue in human isometric contraction. *J Appl Physiol* **29**: 358-367.
- Lind AR. (1983). Cardiovascular adjustment to isometric contractions: static effort. *Handbook of Physiology, Section 2. The Cardiovascular System* **3**: 947-966.
- Lind AR. McNicol GW. (1967). Muscular factors which determine the cardiovascular responses to sustained and rhythmic exercise. *J Can Med Ass* **96**: 706-715.
- Lind AR. Petrofsky JS. (1979). Amplitude of the surface electromyogram during fatiguing isometric contractions. *Muscle Nerve* **2**: 257-264.
- Lloyd AJ. (1971). Surface electromyography during sustained isometric contractions. *J Appl Physiol* **30**: 713-719.

- Lothian F. Farrally MR. Mahoney C. (1993). Validity and reliability of the Cosmed K2 to measure oxygen uptake. *Can J Appl Physiol* **18**: 197-206.
- Marchetti M. Figura F. Ricci B. (1980). Biomechanics of two fundamental sailing postures. *J Sports Med* **20**: 325-332.
- Mateika JH. Duffin J. (1994). Coincidental changes in ventilation and electromyographic activity during consecutive incremental exercise tests. *Eur J Appl Physiol* **68**: 54-61.
- Maughan RJ. (1990). Marathon running. In: *Physiology of Sports*, (Eds. T. Reilly, N. Secher, P. Snell and C. Williams), Chapman and Hall, London, p 121.
- McCloskey DI. Mitchell JH. (1972). Reflex cardiovascular and respiratory responses originating in exercising muscle. *J Physiol* **224**: 173-186.
- McLoughlin E. Hale T. Harrison J. Keen P. (1993). The effects of dietary manipulation on physiological responses to a 30 minute sailing task. *Med Sci Res* **21**: 869-870.
- Moritani T. de Vries HA. (1978). Re-examination of the relationship between the surface integrated electromyogram and force of isometric contraction. *Am J Phys Med* **57**: 263-277.

- Moritani T. Muro M. Nagata A. (1986). Intramuscular and surface electromyogram changes during muscle fatigue. *J Appl Physiol* **60**: 1179-1185.
- Muza SR. Lee LY. Wiley RL. McDonald S. Zechman FW. (1983). Ventilatory responses to static handgrip exercise. *J App Physiol* **54**: 1457-1462.
- Myhre K. Andersen KL. (1971). Respiratory responses to static muscular work. *Resp Physiol* **12**: 77-89.
- Nagata A. Muro M. Moritani T. Yoshida T. (1981). Anaerobic threshold determination by blood lactate and myoelectric signals. *Jap J Physiol* **31**: 585-597.
- Newsholme EA. Leech AR. (1983). In: *Biochemistry for the Medical Sciences*. John Wiley and Sons, Chichester, UK Chapter 9. Metabolism of exercise, p 376.
- Niinimaa V. Wright G. Shephard RJ. Clarke C. (1977). Characteristics of the successful dinghy sailor. *J Sports Med and Phys Fitness* **17**: 83-96.
- Peel C. Utsey C. (1993). Oxygen consumption using the K2 telemetry system and a metabolic cart. *Med Sci Sports Exerc* **25**: 396-400.
- Petrofsky JS. Lind AR. (1980). Frequency analysis of the surface electromyogram during sustained isometric contractions. *Eur J Appl Physiol* **43**: 173-182.

- Phillipson EA. Bowes G. Townsend ER. Duffin J. Cooper JD. (1981). Carotid chemoreceptors in ventilatory responses to changes in venous carbon dioxide load. *J Appl Physiol* **51**: 1398-1403.
- Piehl-Aulin K. Grimby G. Karlsson J. (1977). Sailing. *Idrottsfysiologi rapport* no 16: 28-57.
- Piper H. (1912). *Electrophysiologie Menschlicher muskeln*. Berlin, Springer-Verlag.
- Plyley MJ. Davis GM. Shephard RJ. (1985). Body profile of Olympic class sailors. *The Physician and Sportsmedicine* **13**: 152-167.
- Poole D. Ward S. Whipp B. (1988). Control of blood-gas and acid-base status during isometric exercise in humans. *J Physiol* **396**: 365-377.
- Pudenz V. Dierck TH. Rieckert H. (1981). Heart frequency as a reflection of the length of the boat race course - an experimental study of load imposed during Laser sailing. *Deutsche Zeitschrift für Sportmedizin* **32**: 192-195.
- Putman CA. (1979). A mathematical model of hiking positions in a sailing dinghy. *Med Sci Sports Exerc* **11**: 288-292.
- Reilly T. Secher N. (1990). Physiology of Sports: An overview. *In: Physiology of Sports*, (Eds. T. Reilly, N. Secher, P. Snell and C. Williams), Chapman and Hall, London; pp 465-485.
- Riley JM. (1972). Transmitter for recording respiration rate information by radiotelemetry. *J Appl Physiol* **32**: 259-260.

- Rowell LB. O'Leary DS. (1993). Reflex control of the circulation during exercise: chemoreflexes and mechanoreflexes. *J Appl Physiol* **69**: 407-418.
- Royce J. (1962). Oxygen intake curves reflecting circulatory factors in static work. *Intern Z Angew Physiol* **19**: 222-228.
- Sahlin K. (1986). Muscle fatigue and lactic acid accumulation. *Acta Physiol Scand* **128** (suppl 556): 83-91.
- Sahlin K. Harris RC. Hultman E. (1975). Creatine kinase equilibrium and lactate content compared with muscle pH in tissue samples obtained after isometric exercise. *Biochem J* **152**: 173-180.
- Saltin B. Sjogaard G. Gaffney FA. Rowell LB. (1981). Potassium, lactate, and water fluxes in human quadriceps in muscle during static contractions. *Circ Res* **48** (suppl 1): 18-25.
- Saltin B. Gollnick PD. (1983). Skeletal muscle adaptability: Significance for metabolism and performance, in *Handbook of physiology*, (Eds. L. D. Peachey, R. A. Adrian and S. R. Geiger). Williams and Wilkins Company, Baltimore; Section 10, Chap. 9, p 555.
- Saltin B. (1985). Haemodynamic adaptations to exercise. *Am J Cardiol* **55**(10): 42D.
- Schibye B. Mitchell JH. Payne FC. Saltin B. (1981). Blood pressure and heart rate responses in relation to electromyographic activity and force development. *Acta Physiol Scand* **113**: 61-66.

- Shephard R.J. (1990). The biology and medicine of sailing. *J Sports Med* **9**: 86-99.
- Shephard R. (1992). Muscular Endurance and Blood Lactate In: *Endurance in Sport*. Blackwell Scientific Publications, Oxford: pp 192-200.
- Sjogaard G. Kiens B. Jorgensen K. Saltin B. (1986). Intramuscular pressure, EMG and blood flow during low level prolonged static contraction in man. *Acta Physiol Scand* **128**: 475-484.
- Sjogaard G. Savard G. Juel C. (1988). Muscle blood flow during isometric activity and its relation to muscle fatigue. *Eur J Appl Physiol* **57**: 327-335.
- Spurway N.C. Burns R. (1993). Comparison of dynamic and static fitness-training programmes for dinghy sailors - and some questions concerning the physiology of hiking. *Med Sci Res* **21**: 865-867.
- Stieglitz O. (1993). Fatigue and serum potassium in high performance sailors. *Med Sci Res* **21**: 855-858.
- Tallarida G. Baldoni F. Peruzzi G. Raimondi G. Massaro M. Sangiorgi M. (1981). Cardiovascular and respiratory reflexes from muscles in dynamic and static exercise. *J Appl Physiol* **50**: 784-791.
- Thomas D. (1981). The effects of fatigue on vigilance in sailing. *Beam reach* **11**: 12-13.

- Thorstensson A, Karlsson J, Viitasalo JHT, Luhtanen P, Komi PV. (1976).
Effect of strength training on EMG of human skeletal muscle. *Acta
Physiol Scand* **98**: 232-236.
- Tibes U. (1977). Reflex inputs to the cardiovascular and respiratory centres
from dynamically working canine muscles. *Circ Res* **41**: 332-341.
- Viitasalo JHT, Komi PV. (1977). Signal characteristics of EMG during
fatigue. *Eur J Appl Physiol* **37**: 111-121.
- Viitasalo JHT, Luhtanen P, Rahkila P, Rusko H. (1985). Electromyographic
activity related to aerobic and anaerobic threshold in ergometer bicycling.
Acta Physiol Scand **124**: 287-293.
- Vogiatzis I, Roach NK, Trowbridge EA. (1993a). Cardiovascular muscular
and blood lactate responses during dinghy hiking. *Med Sci Res* **21**:
861-863.
- Vogiatzis I, Spurway NC, Wilson J. (1993b). Telemetric oxygen uptake
measurements during fresh-wind dinghy sailing by national squad
competitors. *In: Proceedings of the XXXII Congress of the International
Union of Physiological Sciences*: 220-221.
- Vogiatzis I, Spurway NC, Wilson J. (1994). On-water oxygen uptake
measurements during dinghy sailing. *J Sports Sci* **12**: 153.

- Vogiatzis I. Spurway NC. Wilson J. Boreham C. (1995a). Assessment of aerobic and anaerobic demands of dinghy sailing at different wind velocities. *J Sports Med Phys Fitness* (in press).
- Vogiatzis I. Spurway N C. Wilson J. Sinclair J. (1995b) The physiological demands of dinghy sailing. Research report No 40. Scottish Sports Council.
- Vogiatzis I. Spurway NC. Wilson J. (1995c). The physiological demands of dinghy sailing at different wind velocities. *J Sports Sci* **13**: 45-46.
- Vogiatzis I. Spurway N. C. Wilson J. Sinclair J. (1995d). The physiological demands of dinghy sailing. Research Digest No 36. Scottish Sports Council.
- Vogiatzis I. Spurway N C. Jennett S. Wilson J. Sinclair J. (1995e). Respiratory and metabolic responses during successive bouts of isometric exercise (simulated dinghy sailing) in humans. *J Physiol* **483**: 132-133 P.
- Vogiatzis I. Spurway N C. Jennett S. Wilson J. Sinclair J. (1995f). Changes in ventilation in relation to changes in electromyographic activity during repetitive bouts of isometric exercise in simulated sailing. *Eur J Appl Physiol* (submitted).
- Whelan RF. Young IM. (1953). The effect of adrenaline and noradrenaline infusions on respiration in man. *Brit J Pharm* **8**: 98-102.
- Wiley R. Lind AR. (1971). Respiratory responses to sustained static muscular contraction in humans. *Clin Sci.* **40**: 221-236.

Wright GR. Clarke J. Niinimaa V. Shephard RJ. (1976). Some reactions to a dry-land training programme for dinghy sailors. *British J Sports Med* 10: 4-10.

Appendix 1

CONSENT FORM

THE WEST ETHICAL COMMITTEE

FORM OF CONSENT FOR PATIENTS/VOLUNTEERS IN CLINICAL RESEARCH PROJECT

Brief Title of Project

"The physiological demands of dinghy sailing".

Patient's Summary (Purpose of study, nature of procedure, discomfort and possible risks in terms which the patient or volunteer can understand.)

The aim of this project is to assess, in more detail than has ever been attempted before, the physiological demands of top-level dinghy sailing. On the water, you will be asked to wear, in various wind-strengths, for periods of about 45 minutes each time, the following apparatus:

- A face mask, for oxygen consumption measurements, with two tubes leading to a radio transmitter strapped to your chest.
- A heart rate meter.
- Electrodes on your thigh, to pick up signal from the muscles.
- A device for measuring the angle of your knee.

In addition, we shall ask you stop 2-4 times during the 45-minutes period, to let us take blood from a prick of your ear lobe, for measurements of the chemical lactate ("lactic acid").

We shall also ask you to come once to the laboratory in Glasgow, and undertake a test to show us the maximum rate at which your body can take up oxygen. You will be given instructions on working a cycle ergometer and breathing through the collection system, and will be allowed to practice. After 5 minutes of warm-up, a technician will tape 3 electrodes to your chest for recording your heart beat.

During the test you will be cycling at 60 revolutions per minute, and every 2 minutes the load will be increased. We shall ask you to keep cycling continuously until you feel that you have to stop. The test usually lasts for 10 to 12 minutes. Qualified medical personnel will be available at all times, against the unlikely event of trouble. Skin-prick blood samples will also be taken twice, for lactate analysis.

All blood sampling involved in this study will be done solely by trained personnel, with full standard precautions. The amount of blood drawn from each skin-prick will be just 5ul — a small drop. There will be little discomfort.

You will of course be totally free to withdraw from the project as a whole, or decline any particular test, at any time. Neither participation in the tests, nor the results obtained, will have any effect on future squad, or representative, selections. Finally, you should know that your participation in this trial may not be of direct benefit to you, but it will help the development of our understanding about the physical demands of sailing.

Before being accepted as a subject in this investigation, you will be required to undergo an appropriate medical examination. This may be done by your own G.P., or by a doctor arranged by the experimenters — whichever you prefer — but in either case your GP. will be informed of your participation in the project, and we shall require his / her name and address for this purpose.

Reporting of Results. It is understood that the results of your test will be reported only to: you and your coach. [Please delete the latter if unacceptable to you].

Consent

I, of
give my consent to the research procedures described above, the nature,
purpose and possible consequences of which have been described to me
by

Signed Date

Witness

Appendix 2

K2 APPARATUS



Figure 1: K2 being worn for on-water measurements by the helmsman of a Laser dinghy.

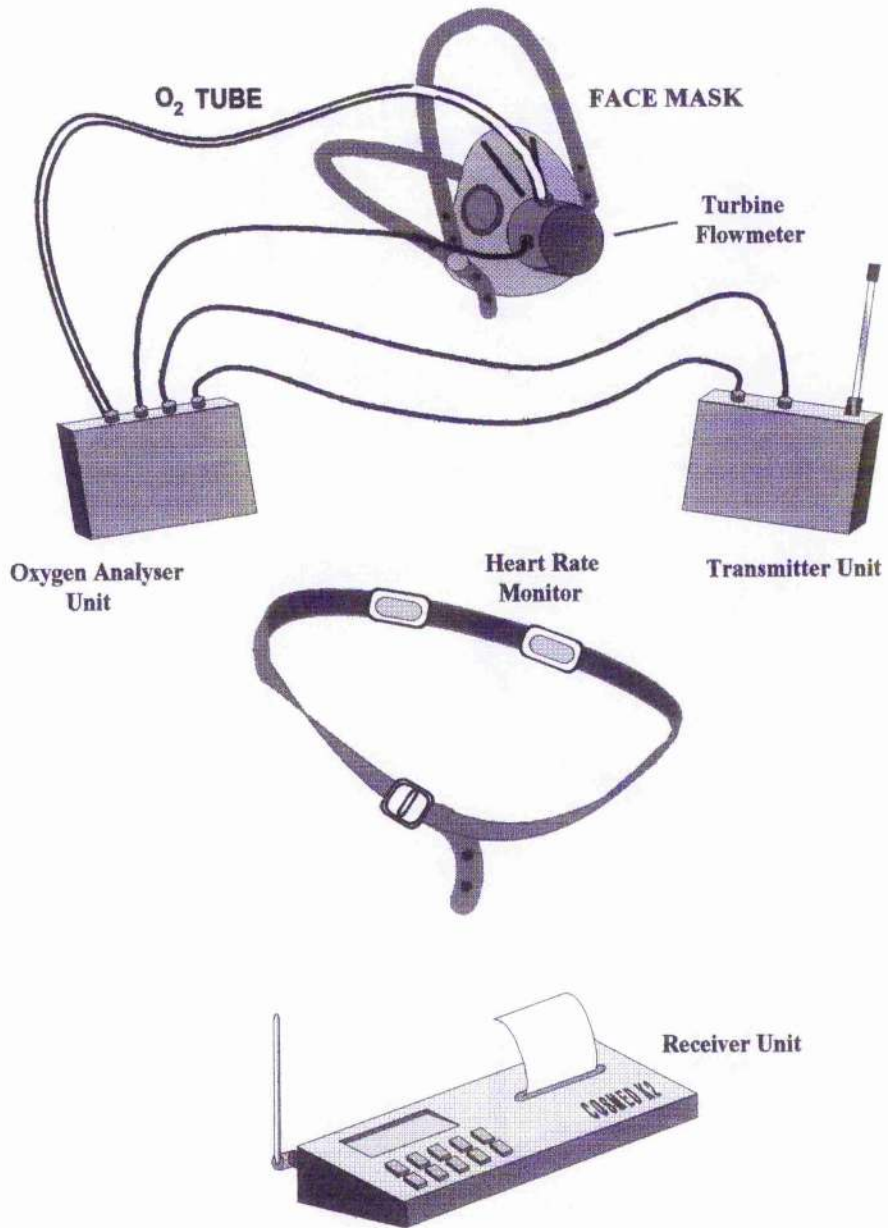

Figure 2: The K2 components.

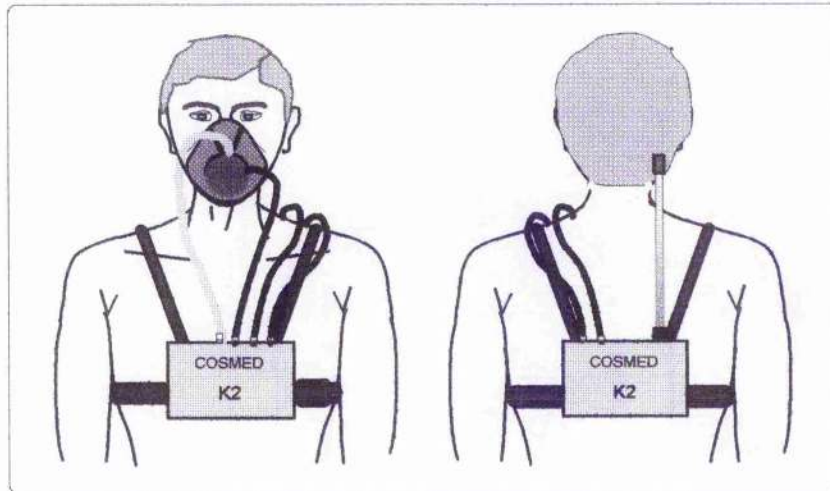

Figure 3: This is how the K2 components are normally worn.

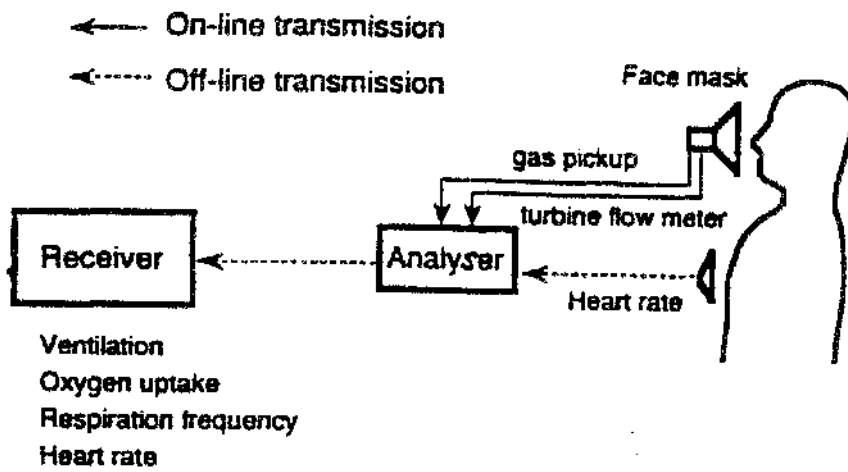

Figure 4: Block diagram of the K2 system showing the principle of its operation.



Figure 5: The motor-boat where the receiving unit of the K2 was located during the on-water measurements.

Appendix 3

PULSE RATE CURVE

pulse

Pulse Rate Curve

mark / hiking actual test / 10: 6:94

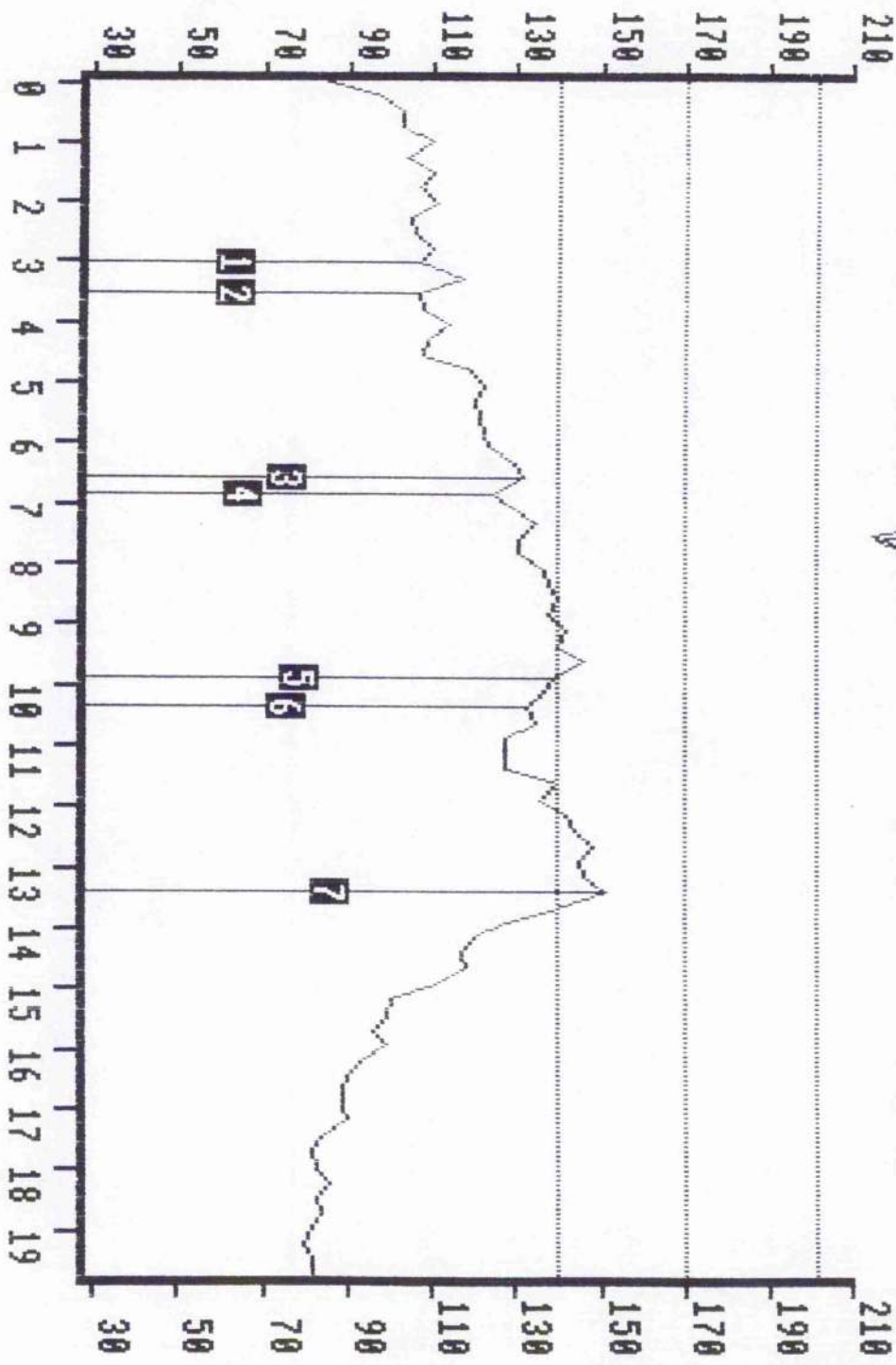

mins

Appendix 4

ELECTROMYOGRAPHY

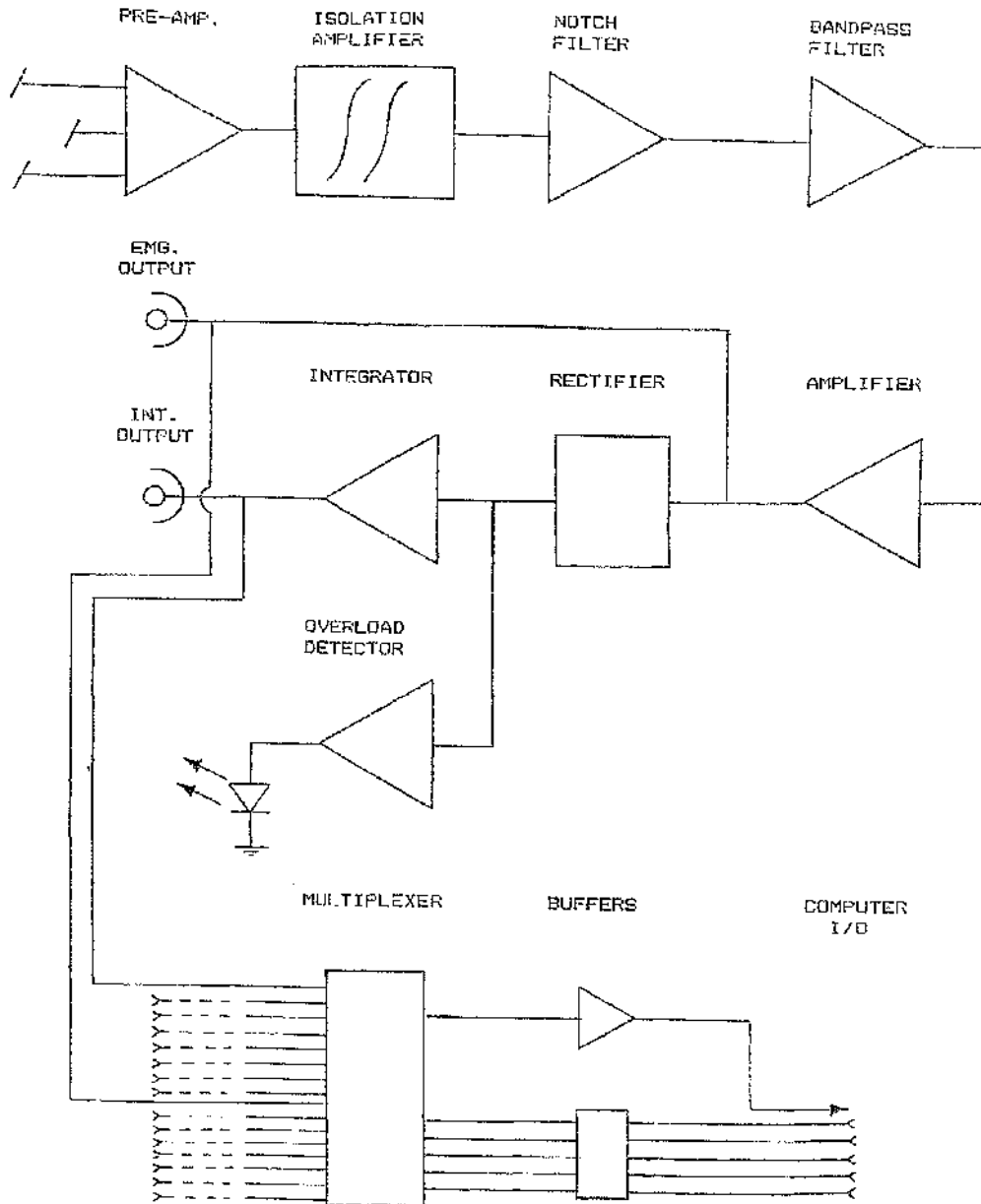

Figure 1: The multi-channel EMG system.

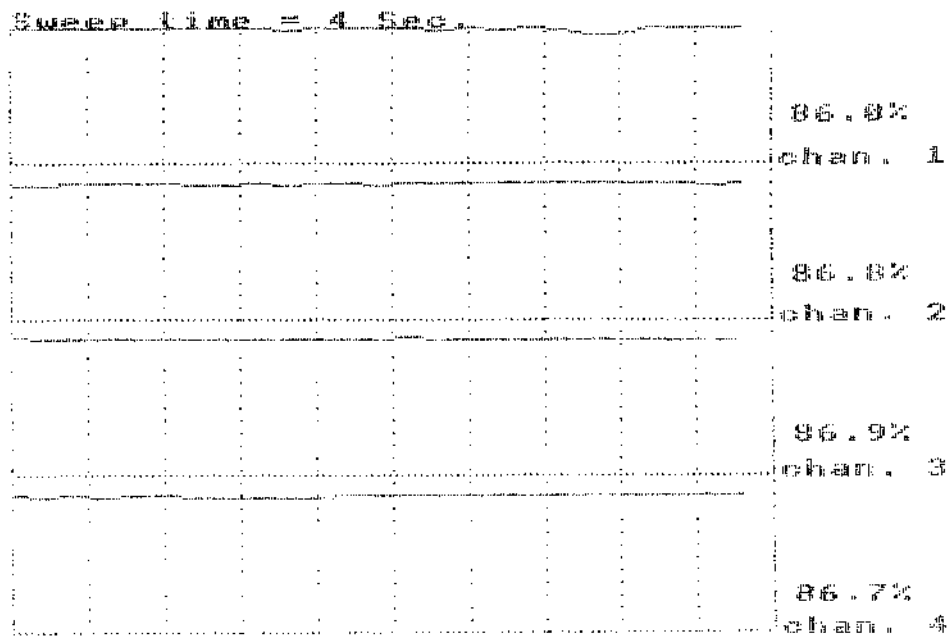
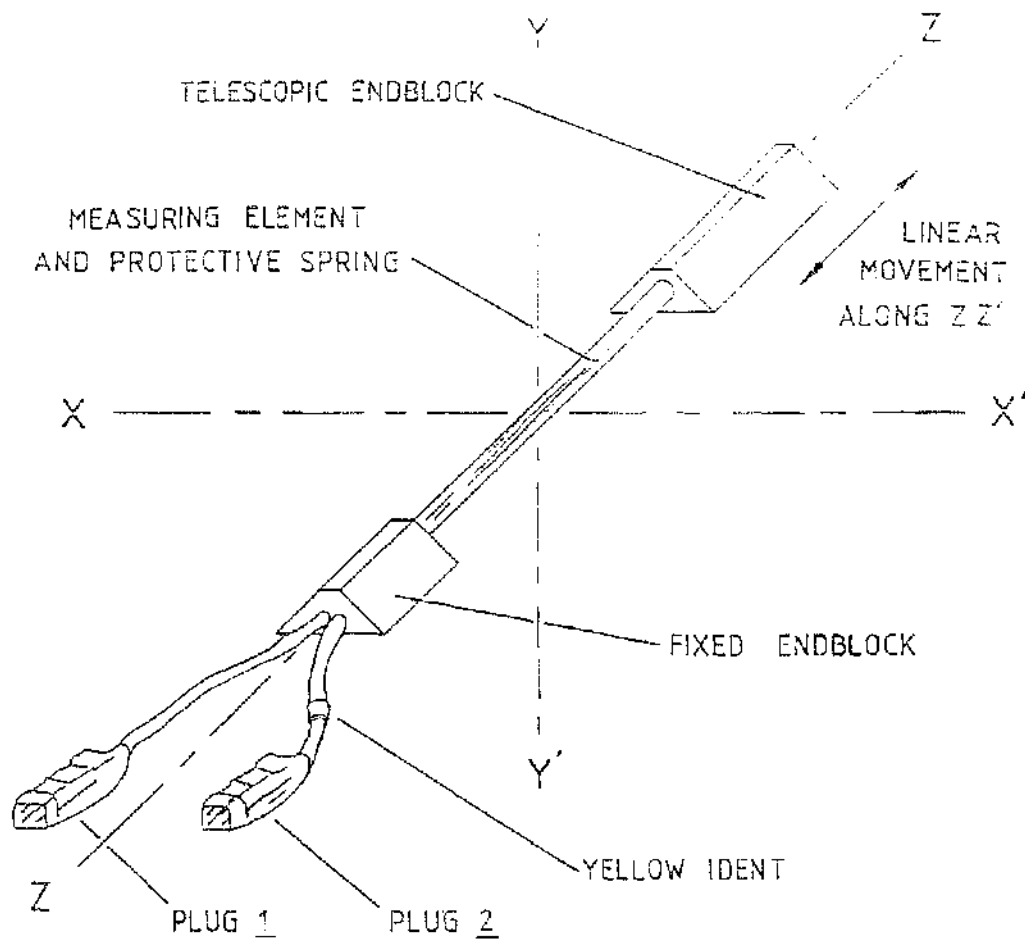

Figure 2: A printed hard copy providing graphical and tabular information of the IEMG activity recorded from all 4 channels. In this sample, the signals were from the Millivolt Calibrator.

Appendix 5

GONIOMETRY



ZZ' - CENTRE AXIS
OF ENDBLOCKS

Figure 1: The twin axis strain electrogoniometer (Penny and Giles - M 110 series Blackwood Limited) which were used to measure and control the angular displacement at hip and knee joints.

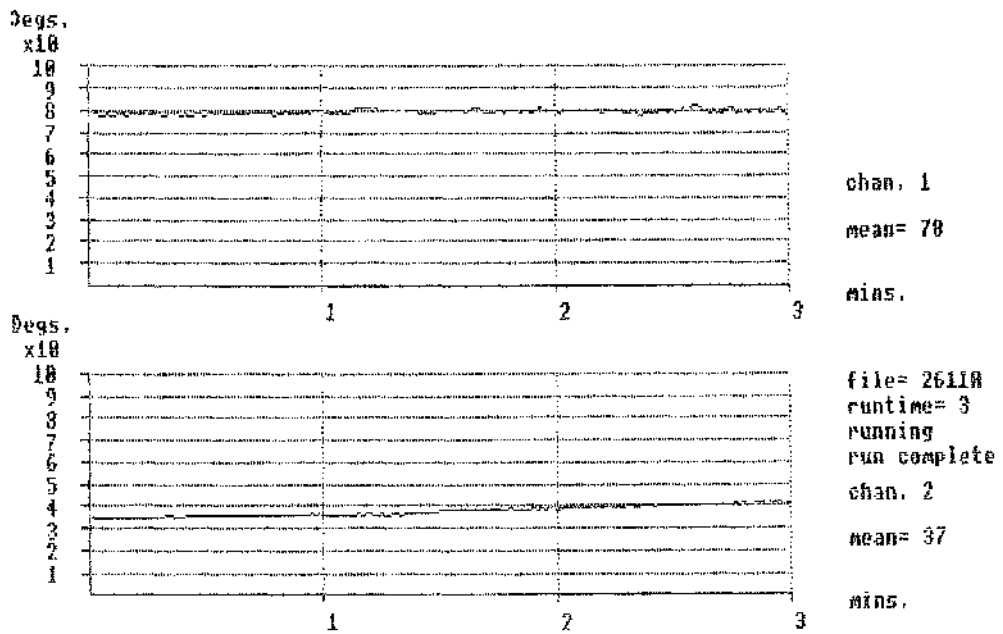

Figure 2: A printed hard copy provided graphical and tabular information about the angular displacement at hip and knee joints.