



# Optimization and cost-benefit assessment of hybrid power systems for off-grid rural electrification in Ethiopia



Kiflom Gebrehiwot <sup>a</sup>, Md. Alam Hossain Mondal <sup>b, c, \*</sup>, Claudia Ringler <sup>b</sup>,  
Abiti Getaneh Gebremeskel <sup>a</sup>

<sup>a</sup> Research & Development Directorate, Ministry of Water, Irrigation and Electricity, Addis Ababa, Ethiopia

<sup>b</sup> International Food Policy Research Institute (IFPRI), 1201 Eye Street, NW, Washington DC, 20005, USA

<sup>c</sup> Department of Electrical and Electronic Engineering, Daffodil International University (DIU), Dhaka, Bangladesh

## ARTICLE INFO

### Article history:

Received 21 August 2018

Received in revised form

5 April 2019

Accepted 16 April 2019

Available online 16 April 2019

### Keywords:

Hybrid system

HOMER model

Solar PV

Wind power

Levelized cost of energy

Net present cost

## ABSTRACT

Standalone solar photovoltaic systems are increasingly being distributed in Ethiopia, but these systems are sub-optimal due to their intermittent power supply. A hybrid system that integrates and optimizes across solar photovoltaic and complementary energy sources, such as wind and diesel generation, can improve reliability, and reduce the unit cost of power production. This study assesses the potential of a hybrid system to electrify a remote rural village in Ethiopia. The Hybrid Optimization of Multiple Electric Renewables model is used to assess primary data, develop a load profile and identify the optimal least-cost system option for the village. A sensitivity analysis was performed to determine the effect of variations in solar radiation, wind speed, and diesel price on optimal system configurations. The results show that a hybrid system with a combination of photovoltaic array, wind turbine, battery and diesel generator is the best option from an economic point of view. To meet the village's daily peak demand of 19.6 kW, energy generation cost is estimated at 0.207 dollars per kilowatt hour and net present cost at 82,734 dollars. The optimal system allows for a reduction of 37.3 tons of carbon dioxide emissions per year compared with diesel-only electricity generation.

© 2019 The Authors. Published by Elsevier Ltd. This is an open access article under the CC BY license (<http://creativecommons.org/licenses/by/4.0/>).

## 1. Introduction

Ethiopia is a low-income country in Sub-Saharan Africa with a population of 110 million people. Rapid population growth is estimated to add a further 30 million people by 2030 [1]. More than 80% of the population resides in rural areas. Two-thirds of the population is under 25 years old, and about 70% are between the ages of 15 and 35 [2]. Electricity is available for 41% of the population, but only 17% of households are connected to the central grid, all in major towns and cities [3].

Though Ethiopia is endowed with vast energy resources such as hydro, solar, wind, geothermal, biomass, coal and natural gas (see Table 1, [4]), the country has not yet been able to develop, transform and utilize these resources for optimal economic development [5]. About 99% of households, 70% of industries and 94% of service enterprises use biomass as the primary source to meet their energy

demands.

To utilize the existing, ample energy resources and to leapfrog to the status of a middle-income country by 2025, the Government of Ethiopia (GoE) inaugurated an ambitious 15-year (2010–2025) Growth and Transformation Plan (GTP), that includes aggressive power generation and connection targets [6]. During GTP I (2010/11–2014/15), installed capacity reached 4206 MW, mainly from hydroelectric (3743 MW; 89%), wind (337 MW; 8%) and thermal (126 MW; 3%) energy sources [7]. GTP-II covers the period 2015/16–2019/20 and aims to construct a total of 14,561 MW generation projects [8]. Of this total, hydropower accounts for 11,237 MW, wind for 1200 MW, solar for 300 MW, geothermal for 1200 MW, biomass for 420 MW, and sugarcane bagasse for 504 MW. In line with increased power generation, GTP II intends to increase the current total length of distribution and high voltage transmission lines to electrify 6565 new towns, and to reduce distribution system losses from 17% to 8% and transmission system losses from 5.3% to 3.0%.

For unelectrified, off-grid areas, solar photovoltaic (PV) systems appear the better choice for bringing modern energy supply to

\* Corresponding author. International Food Policy Research Institute (IFPRI), 1201 Eye Street, NW, Washington DC, 20005, USA.

E-mail address: [a.mondal@cgiar.org](mailto:a.mondal@cgiar.org) (Md.A.H. Mondal).

**Table 1**  
Energy resource potential of Ethiopia.

Resource	Unit	Exploitable reserve	Exploited proportion
Hydropower	MW	45,000	Less than 5%
Solar/day	kWh/m <sup>2</sup>	4–6	Less than 1%
Wind: Power peed	GW m/s	100 > 7	Less than 1%
Geothermal	MW	10,000	Less than 1%
Wood	Million tons	1120	About 50%
Agricultural waste	Million tons	15–20	About 30%
Natural gas	Billion m <sup>3</sup>	113	0%
Coal	Million tons	300	0%
Oil shale	Million tons	253	0%

remote Ethiopian communities. Recognizing this, over the past ten years, governmental as well as non-governmental organizations in Ethiopia have fitted thousands of homes and larger buildings across the country with solar PV-systems. The GoE disseminates two types of systems broadly categorized as solar home systems (SHSs) and solar institutional systems, with the key difference being size. SHSs are available as 8 W, 10 W, 20 W, 40 W, 60 W, 75 W, 80 W, 100 W and 130 W and institutional systems include 300 W for primary schools and 600 W for health posts. The 2010/11–2014/15 GTP aimed to disseminate 153,000 SHSs across all regions, but only 28,735 were distributed. To date, no major study has been conducted into the sustainability of the implemented solar PV systems.

Ethiopia has seen substantial GDP growth, at about 11% annually, for the last eight consecutive years, while the population grew at an average annual rate of 2.5%. The GoE aspires to achieve continued economic development at an annual rate of more than 10%, which requires concomitant growth in the development of electric power supply of more than 14% per year [9].

The experience of other developed and developing countries undergoing rapid economic and population growth shows a substantial level of energy demand being created and the associated pressure on a country's energy infrastructure to match that demand. Ethiopia is an emerging developing country where most people live in rural villages; extending the electricity grid in a timely manner is either financially not viable or practically not feasible, since most villages are geographically isolated, sparsely populated and have low power demands. More than 70% of Ethiopians depend on fossil fuel (mainly kerosene) and solid biomass for lighting. Only about 1% use diesel-based electricity generators for lighting [5]. Biomass fuels have the largest share (92%) of total energy consumption in Ethiopia [10]. The remaining shares are hydrocarbons (7%) and electricity (1%) [11].

Excessive use of biomass and hydrocarbons leads to harmful greenhouse gas emissions, air pollution, and local environmental degradation. In light of this, the Ethiopian government has sectoral and cross-sectoral policies, strategies and plans to replace fossil fuel and solid biomass energy sources with renewable ones, including hydro, wind and solar, to guide modern energy expansion and to maximize the local benefits from the uptake of renewable energies. The most important and recent of these include the Climate Resilient Green Economy Strategy (CRGE) [12], the GTP [6] and the energy sector strategic plan [13].

The CRGE strategy integrates accelerated economic growth with climate resilience and GHG abatement. The four focal strategies are to (a) improve agricultural production practices to enhance food security while reducing emissions, (b) protect forests for economic and eco-system services and as carbon sinks, (c) expand electricity generation from renewable sources of energy, and (d) leapfrog to modern and energy-efficient technologies [12].

The GTP of 2010/11–2024/25 envisages rapid growth (11% per year) and an increased role for industry in the economy (with industrial growth of 20% per year). Development of infrastructure

and, in particular, expansion of energy infrastructure feature prominently in the plan accounting for 40% of the total investment for the period. The plan includes ambitious plans for disseminating standalone off-grid solar technology (3.6 million lanterns/Pico-PV systems and 400,000 solar home systems by 2020) [6].

The energy sector strategic plan (2011–2025) specifies the energy sector vision and goals for the period. The plan reflects, in greater detail, the goals of the GTP; provides quantitative targets for both grid and off-grid electricity as well as for other energy applications. The strategies envisioned for accelerating the uptake of off-grid and alternative energy systems are (a) promoting greater participation of government and non-government actors and improving coordination for greater effectiveness, (b) developing the market for off-grid and alternative systems through public education, and (c) improving access to finance to suppliers and users, again to increase access to these systems.

However, the energy investment plans and strategies remain vague on off-grid electrification and dissemination of hybrid renewable energy system (HRES), even though previous studies have found HRES systems to be more reliable, to produce energy cheaper [14] and to have lower storage requirements than systems consisting of only one energy source [15]. Renewable electricity (wind, solar, small hydropower, etc.) is the globally accepted choice for off-grid electrification [14]. A combination of HRES with a diesel generator and battery offers several advantages such as reduced operating time of the diesel generator, reduced operating cost as well as reduced fuel consumption [16]. The combined system also reduces environmental pollution and increases system reliability [17].

This study develops an optimal hybrid system for the electrification of Golbo II village in Adaa district, Oromia Region, Ethiopia. Golbo II village is typical of rural villages in Ethiopia that are unlikely to be reached by the electric grid over the next decade or two. The village depends on local solutions like kerosene for lighting, traditional biomass (including cow dung) for cooking and baking, and dry cells for radio and cassette players.

To develop the elements of the hybrid system, primary energy demand data were collected through a structured survey questionnaire, focal group discussions, and observations in the field. Techno-economic parameters were also collected as inputs of the HOMER (Hybrid Optimization of Multiple Electric Renewables) model. Primary data were used to establish a daily load profile for the HOMER model to develop an off-grid system that offers an optimal and least-cost way to meet the daily electricity demand in the surveyed village. Sensitivity analyses were performed, considering variations of key parameters such as solar radiation, wind speed and diesel price. The study provides insights about the possible contribution of hybrid systems in remote households in Ethiopia to meet the government's goal of universal electrification by 2025.

### 1.1. Literature review

Several scholars have studied the use of renewable energy systems for off-grid application in Ethiopia, but most of the studies are focused on wind or solar resource assessment and off-grid application of standalone solar PV systems. F. Drake and F. Mulugetta assessed the potential of wind energy for Ethiopia [18]. Solar energy potential for Ethiopia was assessed and presented in Ref. [19]. Both studies apply regression coefficients of the Ångström equation relating sunshine duration to daily solar radiation and Weibull parameters. In 2004, the global Solar and Wind Energy Resources Assessment (SWERA) team released a solar and wind map for Ethiopia [20]. Based on the study the mean annual average daily radiation for the country is estimated at 3.74 kWh/m<sup>2</sup>/day, within a

range of minimal estimated radiation of 1.5 kWh/m<sup>2</sup> in July to a maximum of 4.9 kWh/m<sup>2</sup> in February and March.

Abraha et al. (2013) study the application of a hybrid system in 3 rural villages compared to a diesel-only system [21]. Bekele used HOMER optimization and sensitivity analysis to determine the feasibility of a Wind-PV hybrid system to electrify 200 families in rural Ethiopia [22]. The study concluded that the diesel-only power system (i.e. 100% diesel) was a more feasible option than the solar-wind-diesel system. Another study found that a wind-solar PV system was feasible for remote rural household electrification in Ethiopia [23]. Yet another study identified that the generation cost from wind-PV systems was higher than the existing tariff in Ethiopia [24]. Another study using the HOMER model presented a hybrid micro hydro and wind power system for a rural area in Ethiopia [25] with 660 households. According to the study, the levelized cost of electricity (COE) is \$0.112/kWh from the proposed hybrid system. The COE standalone micro-hydro system increases significantly to reach \$0.035/kWh. A PV-biomass-diesel based hybrid system assessment was performed for rural electrification in India [26]. Similarly, hybrid system assessments were performed for North American communities using the HOMER model [27]. Finally, a standalone PV–Wind–diesel system's performance and feasibility assessment was done for Ras Musherib in the United Arab Emirates [28].

Almost all of the above studies reviewed either PV or PV/wind or wind/hydro hybrid systems and find that the renewable based systems are most feasible. Studies for Ethiopia up to now are less conclusive. This study uses primary values of energy consumption data and also updates the cost of system components for more up-to-date energy systems' planning. This study also combines all potential resources to electrify rural Ethiopia villages. Sensitivity analysis further improves the breadth and depth of the assessment. The study results will be useful for all areas in Ethiopia for off-grid electrification where a reasonable wind speed and solar radiation are available and can also provide insights for other rapidly developing countries in Sub-Saharan Africa.

## 2. Materials and methods

To identify the study site, we were first used NASA data to identify areas with both solar and wind potential for off-grid electricity generation in Ethiopia. This assessment resulted in a large area of the country as there are many areas in Ethiopia with significant solar and wind potential. The second criterion was to identify a location that was sufficiently remote to not be reached by the electric grid but also sufficiently close to urban areas to support both on-farm and off-farm rural activities—reflecting the very rapid urbanization of Ethiopia and Sub-Saharan Africa. The third step was to identify a location where the local administration was supportive of a field study on off-grid electricity. The Water and Energy Bureau of Golbo II Village, Adaa district, Oromia Region, was supportive of the research implementation. Golbo II village representatives supported the collection of primary data. Considering all these issues, Golbo II village is considered as a representative village in Ethiopia for off-grid rural electrification.

Primary data were collected from relevant end users through a questionnaire, focus group discussion and observations during March and April 2018. Officials from the village administration and the Water and Energy Bureau of Oromia Region also helped in providing data. Secondary data were collected mainly by reviewing relevant organizations' annual reports, publications, literature, internet searches, and discussions with local people. All this information was fed into the HOMER energy model to identify a hybrid system that meets the primary energy load and minimizes the total system cost. The mathematical model of the proposed

system components is described in the following.

### 2.1. Mathematical model of the solar energy

The output of a PV array depends on the rated capacity of the PV array, the module derating factor, the solar radiation incident on the P array, the incident radiation at standard test conditions, the temperature coefficient of power, PV cell temperature and the PV cell temperature under standard test conditions. HOMER uses the following equation to calculate the output of the PV array on a tilted surface [20].

$$P_{PV} = Y_{PV} f_{PV} (G_T / G_{T,STC}) [1 + \alpha_P (T_C - T_{C,STC})] \quad (1)$$

where,  $Y_{PV}$  is the rated capacity of the PV array, meaning its power output under standard test conditions [kw],  $f_{PV}$  is the pv derating factor [%]

$G_T$  is the solar radiation incident on the P array in the current time step [kW/m<sup>2</sup>],

$G_{T,STC}$  is the incident radiation at standard test conditions [kW/m<sup>2</sup>],

$\alpha_P$  is the temperature coefficient of power [%/°c].

$T_C$  is the PV cell temperature in the current time step [°c], and

$T_{C,STC}$  is the PV cell temperature under standard test conditions [25°c].

### 2.2. Mathematical model of wind energy

The fundamental equation governing the mechanical power of the wind turbine is given by

$$P_w = 1/2 C_p (\lambda, \beta) \rho A V^3 \quad (2)$$

where,  $\rho$  is air density (kg/m<sup>3</sup>),  $C_p$  is the power coefficient,  $A$  is the intercepting area of the rotor blades (m<sup>2</sup>),  $V$  is average wind speed (m/s), and  $\lambda$  is the tip speed ratio. The theoretical maximum value of the power coefficient  $C_p$  is 0.593, also known as Betz's coefficient.

The Tip Speed Ratio (TSR) for wind turbines is calculated as the ratio of rotational speed of the tip of a blade to the wind velocity. Mathematically, this is can be represented by:

$$\lambda = R\omega/V \quad (3)$$

where,  $R$  is the radius of the turbine (m),  $\omega$  is angular speed (rad/s), and  $V$  is average wind speed (m/s). The energy generated by wind at a certain height can be obtained by the Hellman exponential law as given in Equation (4).

$$VZ/Vz_{ref} = [Z/Z_{ref}]^\alpha \quad (4)$$

where,  $VZ$  is mean wind speed at height  $Z$ .

$Vz_{ref}$  is mean wind speed at the reference height of the study terrain,

$Z$  is study height above the ground, and

$Z_{ref}$  is reference height, here 10 m.

### 2.3. Mathematical model of the battery

The battery state of charge (SOC) is the cumulative sum of the daily charge or discharge transfers. Therefore, SOC is current

integration, which expresses the ratio of the available current capacity to the nominal capacity which is shown below:

$$SOC = 1 - \int i \eta dt / C_n \tag{5}$$

where  $i$  is the battery current;  $C_n$  is the nominal capacity;  $t$  is time and  $\eta$  is the coulombic efficiency defined as the ratio of energy required for charging to the discharging energy needed to regain the original capacity.

2.4. HOMER cost model optimization analysis

The system cost is defined as the sum of PV cost (CPV), WG cost (CWG), battery cost (CBAT), and convertor cost (CCONV),

$$C_{SYSTEM} = CPV + CWG + CBAT + CCONV \tag{6}$$

The annual operating cost  $C_o$  is computed based on the operating costs of all the installed units for the interval  $t$  in a day as shown below.

$$C_o = \left\{ \sum_{t=1}^{365} \left\{ \sum_{t=1}^{24} C_{OWEG}(t) + C_{OPVG}(t) + C_{ODEG}(t) + C_{OBat} \right\} \right\} \tag{7}$$

Total annualized life cycle cost of the system comprises both capital and operating cost,

$$C_{Annual} = (CC_{CRF} + CO) \tag{8}$$

Unit cost of electricity for hybrid energy systems are calculated as:

$$COE = C_{Annual} / E \tag{9}$$

HOMER calculates the total Net Present Cost (NPC):

$$C_{NPC} = C_{ann,tot} / CRF(i, R_{proj}) \tag{10}$$

where,  $C_{ann,tot}$  is the total annualized cost,  $i$  is the annual real interest rate and  $R_{proj}$  is the project lifetime and CRF is the capital recovery factor given by Equation (2), where  $N$  is the project lifetime in years:

$$CRF(i, N) = i(1 + i)^N / (1 + i)^N - 1 \tag{11}$$

To calculate the COE, HOMER divides the annualized cost of producing electricity (the total annualized cost minus the cost of serving the thermal load) by the total useful electric energy production as shown in Equation (12) below:

$$COE = (C_{ann,tot} - C_{boiler} E_{thermal}) / (E_{prim, AC} + E_{prim, DC} + E_{def} + E_{grid,sales}) \tag{12}$$

where,  $C_{ann,tot}$  is total annualized cost of the system,  $C_{boiler}$  is boiler marginal cost,  $E_{thermal}$  is the total thermal load served,  $E_{prim, AC}$  is the AC primary load served,  $E_{prim, DC}$  is the DC primary load served,  $E_{def}$  is the deferrable load served and  $E_{grid,sales}$  is total grid sales. In our case, since we do not have a thermal load,  $E_{thermal}$  will be zero.

2.5. Study site and energy consumption patterns

This paper designs a hybrid system for the electrification of a remote rural village named Golbo II in Adaa district, Oromia Region, Ethiopia, which lies between longitudes 38°51' to 39°04' East and Latitudes 8°46' to 8°59' North, as shown in Fig. 1. The primary source of income and livelihood in Golbo II is agriculture. The

village covers a land area of 1750 km<sup>2</sup>. Most of the land (90%) is plain highland between 1600 and 2000 m above sea level. Adaa district has a sub-tropical climate and receives 860 mm of rain per annum. The main rainy season is from mid-June to September, followed by a dry season that might be interrupted by a shorter rainy season in February and March [29].

The surveyed area is not connected to the national electricity grid. The nearest electrified village is Bekejo, at a distance of 10 km. Households in the study area meet their energy requirements through traditional time- and money-consuming energy sources. As shown in Table 2, all use dry cell batteries and kerosene for lighting, dry cell batteries for radio, and cow dung for cooking and baking (wood is not an option because of already high levels of deforestation in the area). Health problems due to toxic gases emissions from the dung, lowered agricultural productivity from removing soil nutrients [30] Regarding weekly fuel consumption, an average family with five household members and three houses uses 900 ml of kerosene for lighting, 500 kg of dung for baking, 100 kg for cooking and 50 kg for making coffee. Kerosene is obtained from the nearest town market, and cellphones can be charged at Bekejo, 10 km away.

2.6. The model

HOMER is a computer model developed by the National Renewable Energy Laboratory, USA, to assist in the design of micropower systems and to facilitate the comparison of power generation technologies across a wide range of applications. HOMER models a power system's physical behavior and its life-cycle cost, which is the total cost of installing and operating the system over its lifespan. HOMER allows the user to compare many different design options, based on their technical and economic advantages. It also assists in understanding and quantifying the effects of uncertainty or variations in the inputs.

HOMER performs simulation, optimization, and sensitivity analyses. In the simulation process, the model determines the technical feasibility and life-cycle cost of a particular energy system configuration during each hour of the year. In the optimization

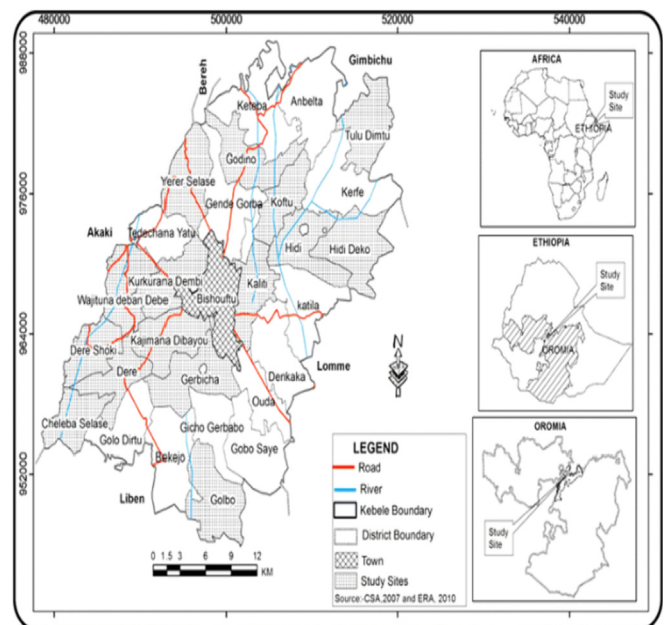

Fig. 1. Map showing the location of Golbo II village in Adaa District.

**Table 2**  
Household energy use profile in Golbo II village, Adaa district.

Type of energy use	Fuel type	Time of use	Distance	Price/week	Risk
Baking	Animal dung	From 5 to 7 AM & 6PM–8PM	Short	Zero (from own cattle)	Health problems due to toxic gas emissions from the dung, lowered agricultural productivity from removing soil nutrients
Lighting	Dry cell & kerosene	From 5 to 7 AM & 7–9 PM	10 km (long)	USD 1.3 (ETB 36) for Dry-cell and USD 1.0 (ETB 27) for kerosene (9 Birr/300 ml)	Health problems due to toxic gas emissions from kerosene
Cooking	Animal dung	From 6 to 7 AM & 6–8PM	Short	Zero (from own cattle)	Health problems due to toxic gas emissions from the dung, lowered agricultural productivity from removing soil nutrients
Coffee	Animal dung	From 7 to 8 AM & 5–6PM	Short	Zero (from own cattle)	Health problem due to toxic gas emissions from the dung and lowered agricultural productivity from removing soil nutrients
Cellphone	Charging from nearest town (Bekejo)	When necessary/ Only for communication	10 km (long)	USD 0.3 (ETB 9) (USD 0.1 (ETB 3) per charging)	Long distance travel for charging

process, HOMER simulates many different possible system configurations that satisfy the technical constraints at the lowest life-cycle cost. It also determines the optimal value of the variables over which the system designer has control, such as the mix of components that make up the system and the size or quantity of each. In the sensitivity analysis process, HOMER undertakes multiple optimizations under a range of input assumptions to quantify the effects of variations in the input parameters. When used for sensitivity analysis, the model supports assessment of the effects of uncertainty or changes in the variables over which the user has no control, such as wind-speed, solar radiation or future fuel prices [14].

## 2.7. Electrical load demand for households in Golbo II village

The load profile for a hybrid system was created from the survey outcomes. The village has residential houses, public institutions (one school and one health center), and a church. Based on the survey, the electrical load demand of the site is very low, and dominated by lighting. Lighting, radio, charging cellphones, TV, cook stoves, baking stoves, and fans were found to be households' load demand priorities (from highest to lowest). The load demand for a single household is presented in Table 3. A total of 20 households were surveyed (out of a total of 200 in the village) and it was found that most of the households' energy demand patterns are similar.

The types and volumes of energy demand in the surveyed area are simple and do not require large quantities of electrical energy, presumably as a result of not having been connected with the national grid. A household needs electricity for lighting, operating a radio/TV, and charging a cellphone. This load is based on four energy efficient lamps (compact fluorescent bulbs, 11 W each), a cellphone charger (5 W) and a television set (30 W) for each family in the village. Timing of electricity used for lighting is the same, with limited variation between winter and summer as a result of changes in the times of sunset and sunrise. Average daily TV/radio operating time is 2 h; for lightbulbs about four hours per day. The village comprises 200 households, and total household demand for the studied area is estimated at 58.2 kWh per day.

### 2.7.1. Golbo health post center

The health post has four rooms: one patient waiting room, one treatment room, one delivery room, and one vaccine storeroom. Other load demands are vaccine refrigerator, sterilizer, tape/cassette player, and TV. The estimated load profile for the health center is presented in Table 3. A significant amount of electricity is needed to store vaccines, and the average daily demand for the center is 1.082 kWh (see Table 3).

### 2.7.2. Electricity demand for the school

There is only one primary school in the village (from grades 1–8), with a laboratory, a library, a director's room, ten teaching classrooms and two toilets. On average, there are 60 students in each classroom and the school has no TV/radio and microphone service, because of it is not connected to the grid. Table 3 shows the electrical load demand for the school, and its average daily energy demand of 1.134 kWh.

### 2.7.3. Electricity demand for the church

The survey determined that the church only needs a lighting load and a fan for cooling during times of great heat. Table 3 presents the load profile for the church. Two cooling fans are required, with a capacity of 60 W each to operate four hours per day.

## 2.8. Proposed hybrid system and input parameters

The surveyed load data were synthesized by specifying typical daily load profiles and then including some randomness of daily 15% and hourly 10% noise in the HOMER model. These have scaled up the annual peak load to 19.6 kW and the primary load to 108 kWh/day. Overall hourly and monthly loads of Golbo II village are presented in Figs. 2 and 3.

The proposed hybrid system for the studied village is shown in Fig. 4. The system consists of a solar PV, wind turbine, diesel generator and battery storage with a hybrid AC to DC bus bar. HOMER simulates the operation of a system by calculating the energy balance for each of the 8760 h in a year. The diesel generator and battery are considered in this system design for continuous power supply when electricity is not being generated from the wind turbine and solar PV. Different sizes and combination of components are simulated to find the optimal design of the hybrid system to meet the projected energy demands.

During peak load, diesel generator and storage battery operate in parallel mode and, when the load is low, either the diesel generator or the storage battery can supply the load. Due to this parallel operation, the capital cost of the diesel generator and inverter can be reduced. In addition to the AC–DC conversion, the converter controls the operation of the total system by selecting the most appropriate mode of operation at the appropriate time without power interruption.

### 2.8.1. Renewable energy resources

According to the National Aeronautics and Space Administration (NASA), the annual average daily radiation on a horizontal surface in the study area is 6.06 kWh/m<sup>2</sup> and the clearness index (atmospheric cleanliness is defined by the clearness index) is 6.0 throughout the year. Table 4 presents monthly solar radiation,

**Table 3**  
Estimated electrical load demand in Golbo II village.

Appliance	Quantity	Load (watt)	Total watt	Hours of operation per day	Watt hour per day
<b>Households</b>					
Lightbulbs	4	11	44	4	176
Radio	1	5	5	3	15
Cellphone-charging	4	5	20	2	40
20-inch LED TV	1	30	30	2	60
Total watt hour per day for total households					58,200
<b>Health post</b>					
Patient waiting room lighting	1	11	11	5	55
Treatment room lighting	1	11	11	5	55
Delivery room lighting	1	8	8	4	32
Vaccine store room lighting	1	8	8	3	24
Outdoor lighting	1	11	11	12	132
Toilet lighting	1	8	8	4	32
Vaccine refrigerator	1	37.2	37.2	10	372
Television	1	60	60	6	360
Tape/radio	1	5	5	4	20
Total watt hour per day for health post					1082
<b>School</b>					
Light bulbs (total)	16	11	176	4	704
Radio	1	5	5	6	30
TV	1	60	60	6	360
Microphone	1	20	20	2	40
Total watt hour per day for school					1134
<b>Church</b>					
Light bulbs	4	11	44	4	176
Fan	2	60	120	4	480
Total watt hour per day for the church					656
Total daily consumption in Golbo II village					61 kWh

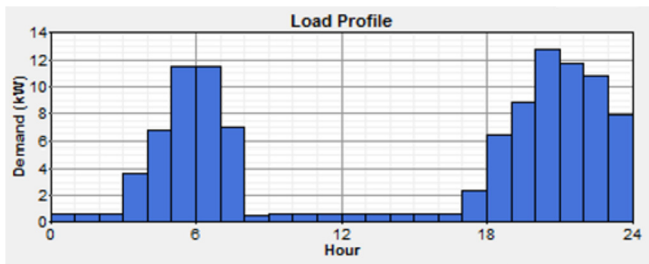

**Fig. 2.** Hourly load profile in Golbo II village.

temperature and wind speed for the site. The highest solar radiation is 6.57 kWh/m<sup>2</sup> in February and the lowest is 5.23 kWh/m<sup>2</sup> in July. The average daily solar radiation data show that the study site is very appropriate for PV electricity generation.

Wind-speed data are not readily available for this location. However, monthly average wind speed data at 25 m height could be obtained from the NASA Surface Meteorology and Solar Energy database. The average wind speed in the selected area at 25 m is between 3 m/s and 4.37 m/s, with the lowest values in August and September and the maximum values in December. Monthly average wind data are presented in Table 4.

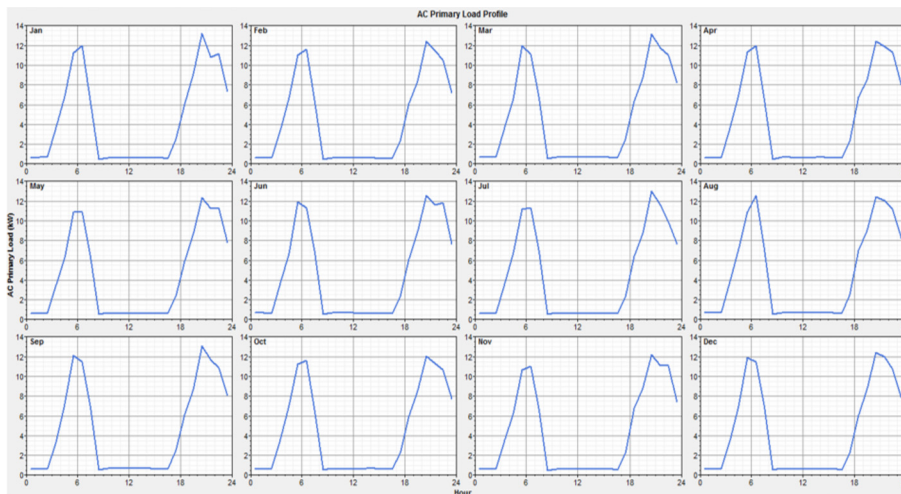

**Fig. 3.** Monthly load profile of Golbo II village.

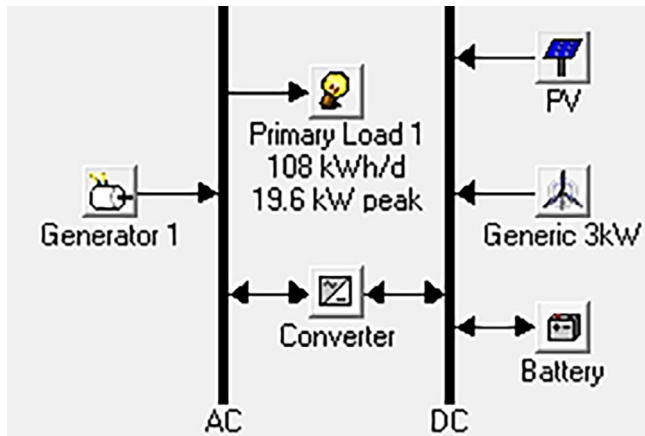

Fig. 4. Configuration of proposed renewable energy integrated off-grid system for Golbo II village.

### 2.8.2. Techno-economic inputs

There are five major system input components: wind turbine, solar PV-module, diesel generator, power converter and battery bank. Cost is one of the most important factors that determine the market penetration of renewable energy technologies in the power generation system. Recognizing this, the Government of Ethiopia waived the import/custom duty on imported renewable energy technologies beginning in November 2009. The following sections discuss available hybrid system components and their techno-economic parameters.

#### (a) Solar PV

The HOMER model deals with solar PV array in terms of rated kW, not in  $m^2$ . The model considers that the output of the PV array is linearly proportional to the incident solar radiation. If the solar radiation is  $0.80 \text{ kW}/m^2$ , the array will produce 80% of its rated output [31]. The solar PV modules, composed of several solar cells, are clustered in a series-parallel arrangement to form solar arrays with the necessary capacity. In this study, proposed solar PV array sizes are considered: 0 kW (no PV), 5 kW, 10 kW, 14 kW, 17 kW, 20 kW and 25 kW. The temperature effect is also considered in this simulation as the electricity production is roughly anti-linear in the temperature range under which solar panels are exposed or solar PV becomes less efficient when temperature increases. A derating factor of 95% is applied in this modeling to take into account varying effects of temperature and dust on the panels. A slightly lower derating factor can be applied in very hot climate areas.

Table 4  
Solar radiation ( $\text{kWh}/m^2/\text{d}$ ) and wind-speed (m/s) in the study area.

Month	Air temperature	Daily solar radiation –horizontal	Clearness Index	Wind-speed
January	18.5	6.08	6.080	4.36
February	20.1	6.57	6.570	3.98
March	21.5	6.52	6.520	3.85
April	21.5	6.31	6.310	3.98
May	21.3	6.36	6.360	3.72
June	19.4	6.02	5.770	4.36
July	18.2	5.23	5.230	3.98
August	18.1	5.36	5.360	3
September	18.6	5.84	5.840	3
October	18.8	6.31	6.310	4.11
November	18.3	6.27	6.270	4.11
December	17.9	6.08	6.080	4.37
Annual average	19.3	6.05	6.0	3.901

Table 5  
Technical parameters and cost consideration of solar PV.

Parameter	Unit	Value
Tilt angle	Degree	0
Azimuth angle	Degree	0 (W of S)
Ground reflectance	Percent (%)	20
Derating factor	Percent (%)	95
Capital cost	USD/kW	1500
Replacement	USD/kW	1000
Operation and maintenance (O&M) cost	USD/year	50
Tracking system	–	No tracking
Lifetime	Year	20

The technical and economic parameters of the selected PV array are presented in Table 5. Capital cost of solar PV is at USD 1500/kW (USD 1 = ETB 27), which includes other associated costs such as transport, labor, logistics and installation of the PV system.

#### (b) Wind turbine

A wind turbine uses wind to convert mechanical energy into electrical energy. The turbines normally generate electricity when the wind speed is between 2 and 4 m/s (the turbine blade starts to spin) and 25–30 m/s (cut-off wind speed) [32]. This study used a 3 kW generic DC power output wind turbine to model wind speed at 25 m height in the study area. Technical parameters and cost assumptions of the selected wind turbine are presented in Table 6.

#### (c) Diesel generator

The cost of a diesel generator depends on its size. The fuel used by the diesel generator in HOMER is modeled by a linear curve characterized by a slope and an intercept at no load. The slope and intercept for a 5 kW diesel generator is about  $0.33 \text{ l}/\text{h}/\text{kW}$  [31]. The diesel generators considered here were 0 kW, 3 kW, 7 kW, 11 kW and 15 kW. A lower heating value of  $43.2 \text{ MJ}/\text{kg}$ , density of  $820 \text{ kg}/m^3$ , carbon content of 88% and sulfur content of 0.33% was assumed for the technology. Technical and economic parameters of the diesel generator are presented in Table 7.

#### (d) Battery storage

The battery is an important part of a hybrid system since it stores surplus energy and supplies deficit energy, thus maintaining stability in a microgrid operation. HOMER uses the kinetic battery model to find the amount of energy that can be absorbed by or withdrawn from the battery storage for each time step. The maximum charge and discharge power provide the allowable range

**Table 6**  
Techno-economic specifications of wind turbine.

Parameter	Unit	Value
Rated power	kW	3
Starting wind speed	m/s	1
Hub height	M	25
Cut-off wind speed	m/s	14
Capital cost	USD/kW	2000
Replacement	USD/kW	1600
O&M cost	USD/year/turbine	50
Lifetime	Year	20

**Table 7**  
Technical parameters and cost assumptions for diesel generators.

Parameter	Unit	Value
Capital cost	USD/kW	250
Replacement	USD/kW	200
Operation and maintenance cost	USD/h	0.3
Operational lifetime	Hours	15,000
Minimum load ratio	Percent (%)	30
Fuel curve intercept	l/h/kW rated	0.05
Fuel curve slope	l/h/kW rated	0.33
Fuel (diesel) price	USD	0.7

for the power into and out of the battery storage in any time step. The battery used for the system is the Hoppecke model with a rating of 2 V, 3000 Ah nominal capacity, with lifetime throughput of 10,222 kWh. The battery strings used in the simulation contained the following number of batteries: 8, 20, 22, 24, and 25. The specification of battery storage is presented in [Table 8](#).

#### (e) Converter

A power converter was used in this simulation to maintain the flow of energy between the AC and DC components. A bi-directional converter connects the DC and AC bus which converts the DC voltage to AC voltage to supply energy to the load. [Table 9](#) gives the technical and economic parameters of the converter.

#### 2.9. Hybrid system control parameters and constraints

A 20-year proposed project life was considered. The annual interest rate is fixed at 7% [33], the maximum renewable fraction was considered as a range from 0% to 100% and the maximum annual capacity shortage assumed at 7%. The hybrid system control parameters applied in the simulation run are summarized in [Table 10](#). The spinning reserve and system constraints are furnished in [Tables 11 and 12](#), respectively.

##### 2.9.1. Dispatch strategy

The type of dispatch strategy which will be optimal for the

**Table 8**  
Specifications of battery storage.

Parameter	Unit	Value
Nominal voltage	Volt	2
Nominal capacity	Ah (kWh)	3000
Maximum charge current	A	1
Round trip efficiency	Percent (%)	86
Minimum stage of charge	Percent (%)	30
Capital cost	USD/kWh	400
Replacement cost	USD/kWh	300
Operation and maintenance cost	USD/year	20
Lifetime	Year	6

**Table 9**  
Technical parameters and cost assumptions for converter.

Parameter	Unit	Value
Inverter efficiency	Percent (%)	90
Rectifier relative capacity	Percent (%)	75
Rectifier efficiency	Percent (%)	85
Capital cost	USD/15 KW	1300
Replacement	USD/15 KW	1000
Operation and maintenance cost	USD/year	5
Lifetime	Year	10

proposed system depends on various characteristics, including the sizes of the generators and battery bank, the price of fuel, and the operation and maintenance cost of the generators. There are two types of dispatch strategies in the HOMER model, known as load-following and cycle-charging. Under the load-following strategy, a generator produces only enough power to serve the load and does not charge the battery bank. Under the cycle-charging strategy, whenever a generator operates it runs at its maximum rated capacity (or as closely to that as possible without incurring excess electricity) and charges the battery bank with the excess. In the proposed system both load following and cycle charging were considered, to allow HOMER to simulate both strategies and to determine which is optimal in a particular situation [34].

#### 2.10. Performance metrics

HOMER selects the optimal system configurations based on total NPC and COE. The NPC of a system refers to the present value of all the associated costs during the project lifetime minus the present value of all revenues earned over the project lifetime. The cost includes capital investment cost, replacement cost, operation and maintenance cost, fuel cost and emissions penalties. However, the COE is also a useful metric to measure the system cost. It is the average cost per kWh of useful electrical energy generated by the system. Penetration rate (%) of renewable energy in any system is also considered, along with NPC and COE, for optimal system selection.

### 3. Results and discussion

This section presents optimization results generated by the HOMER model as well as results for electricity production for the optimal hybrid system. Sensitivity analysis is also performed in this section considering variation of data for key parameters such as diesel price, solar radiation and wind speed.

#### 3.1. Optimization result

The HOMER model performs simulations, optimization and sensitivity analysis in order to identify the most feasible hybrid system combination in terms of cost and technical aspects, based on the given constraints and inputs. The model presents optimum results under two categories: overall optimization and categorized optimization result tables according to their initial capital, NPC, COE, dispatch type, renewable energy penetration or fraction, and capacity shortage.

[Fig. 5](#) shows the overall optimization results with many possible system configurations whose total NPC is only slightly higher than that of the optimal configuration. [Fig. 6](#) presents optimization result by category. It shows top-ranked, least-cost systems from each optimal system configuration. The leveled COE and NPC of the optimal system configurations are shown in [Figs. 7 and 8](#).

HOMER results show that the PV-wind turbine (WT)-diesel



**Table 10**  
Hybrid system control parameters used in HOMER.

Parameter	Option available in HOMER	Option used
Load following	Yes or no	Yes
Cycle charging	Yes or no	Yes
Apply set point	Yes or no	Yes
Set point state of charge	—	80
Allowing multiple generators	Yes or no	Yes
Multiple generators can operate in parallel	Yes or no	Yes

**Table 11**  
Spinning reserve inputs for the system design.

Parameter	Value
Percentage of annual peak load	0
Percentage of hourly load	10
Percentage of hourly solar output	32
Percentage of hourly wind output	50

**Table 12**  
Other constraints used in this modeling.

Parameter	Value
Maximum unserved energy	5%
Maximum renewable fraction	100%
Minimum battery life	6 years
Maximum annual capacity shortage	7%

generator (DG)-battery system is the best least-cost optimal configuration (Figs. 5 and 6, first option) to meet the village's electricity demand. The system consists of 20 kW of solar PV array, three wind turbines (3 kW each), a 5 kW capacity diesel generator and 24 strings of batteries with a load-following dispatch strategy. It has a total NPC of USD 82,734 and a COE of USD of 0.207/kWh. This system requires a minimum amount of diesel (1121 L per year) as renewable energy penetration is very high. This configuration is not only least cost but also emits minimal CO<sub>2</sub> to the environment. Therefore, it can be considered as the best system configuration from a reliability, economic and environmental points of view.

The PV-DG-battery option consists of a PV array (20 kW), 24 strings of batteries and a diesel generator with 7 kW capacity, with

	PV (kW)	G3	Gen1 (kW)	Batt.	Conv. (kW)	Disp. Strgy	Initial Capital	Total NPC	COE (\$/kWh)	Ren. Frac.	Capacity Shortage	Diesel (L)	Gen1 (hrs)	Batt. Li. (yr)
	20	3	5	24	19	LF	\$48,497	\$82,734	0.207	0.94	0.06	1,121	882	7.4
	20	3	5	22	19	LF	\$47,697	\$83,328	0.210	0.93	0.07	1,325	1,030	7.0
	17	3	7	24	19	LF	\$44,497	\$94,862	0.211	0.89	0.05	2,039	1,181	7.9
	17	3	7	22	19	LF	\$43,697	\$85,297	0.213	0.88	0.06	2,212	1,272	7.4
	20	3	7	24	19	LF	\$42,997	\$85,754	0.214	0.87	0.06	2,233	1,303	7.5
	20	3	3	24	19	CC	\$47,997	\$86,143	0.217	0.92	0.07	1,533	1,682	7.1
	20	3	7	24	19	LF	\$48,997	\$86,227	0.211	0.93	0.04	1,450	865	7.4
	17	3	7	20	19	LF	\$42,897	\$86,437	0.217	0.87	0.07	2,474	1,424	7.0
	20	3	7	22	19	LF	\$42,197	\$86,998	0.218	0.86	0.07	2,510	1,460	7.1
	20	3	7	22	19	LF	\$48,197	\$87,534	0.216	0.91	0.04	1,726	1,024	7.0
	20	3	7	20	19	LF	\$47,397	\$89,395	0.222	0.90	0.06	2,083	1,220	6.7
	20	3	11	24	19	LF	\$49,997	\$91,535	0.220	0.91	0.01	1,910	810	7.4
	17	3	11	24	19	LF	\$45,497	\$92,089	0.222	0.86	0.01	2,687	1,109	7.9
	17	3	5	24	19	CC	\$43,997	\$92,220	0.228	0.84	0.05	2,868	1,897	7.2
	20	3	5	24	19	CC	\$48,497	\$92,791	0.228	0.88	0.04	2,218	1,500	7.0
	17	3	11	22	19	LF	\$44,697	\$93,176	0.224	0.85	0.01	2,922	1,205	7.4
	17	3	5	22	19	CC	\$43,197	\$93,574	0.233	0.82	0.06	3,158	2,103	6.8
	20	3	11	24	19	LF	\$43,997	\$93,734	0.226	0.85	0.01	2,956	1,227	7.5
	20	3	11	22	19	LF	\$48,197	\$93,767	0.225	0.90	0.01	2,276	961	7.0
	20	3	5	24	19	CC	\$42,497	\$94,031	0.235	0.82	0.06	3,185	2,120	6.9
	17	3	11	20	19	LF	\$43,897	\$95,367	0.230	0.84	0.02	3,292	1,354	7.0
	20	3	11	22	19	LF	\$43,197	\$95,882	0.231	0.83	0.02	3,326	1,370	7.1

**Fig. 5.** Overall HOMER optimization results according to the total net present cost.

	PV (kW)	G3	Gen1 (kW)	Batt.	Conv. (kW)	Disp. Strgy	Initial Capital	Total NPC	COE (\$/kWh)	Ren. Frac.	Capacity Shortage	Diesel (L)	Gen1 (hrs)	Batt. Li. (yr)
	20	3	5	24	19	LF	\$48,497	\$82,734	0.207	0.94	0.06	1,121	882	7.4
	20	3	7	24	19	LF	\$42,997	\$85,754	0.214	0.87	0.06	2,233	1,303	7.5
	3	7	20	19	CC	\$17,397	\$141,126	0.352	0.16	0.06	12,973	5,644	9.4	
	7	20	19	CC	\$11,397	\$153,249	0.384	0.00	0.07	15,278	6,615	10.1		

**Fig. 6.** Categorized optimization results according to total net present cost.

a load-following dispatch strategy. This system has a total NPC of USD 85,754, a COE of USD 0.214/kWh, and consumption of diesel is about 2233 L per year.

The WT-DG-battery system consists of a three-unit wind turbine, 20 strings of batteries and a diesel generator of 7 kW capacity. As shown in Figs. 5, 7 and 8, this system has total NPC of USD 141,126 and COE of USD 0.352/kWh, with a cycle-charging dispatch strategy. Therefore, this system is not as viable from an economic point of view as the PV-WT-DG-battery and PV-DG-battery systems as the total NPC and COE are higher, and due to the emission of 37 tons of CO<sub>2</sub> per year with a renewable energy penetration rate of only 16%.

The DG-battery system, needing a diesel generator of 7 kW capacity and 20 batteries, with a cycle-charging dispatch strategy has the poorest results, with a high COE at USD 0.384 per kWh, a total NPC of USD 153,249, and 40 tons per year of CO<sub>2</sub> emissions, which is significantly higher than the WT-DG-battery and PV-DG-battery configurations. Therefore, this fossil fuel based system is neither an economically viable nor an environmentally friendly way to meet the electricity demand.

The WT-DG-battery and DG-battery systems are highly dependent on fossil fuel (diesel), which increases COE compared to the PV-WT-DG-battery and PV-DG-battery systems. Yearly diesel consumption for the WT-DG-battery and DG-battery systems is 12,973 L and 15,278 L, respectively.

The COE increases from USD 0.20/kWh in the PV-WT-DG-battery system to USD 0.38/kWh in the DG-battery system. The PV-WT-DG-battery and PV-DG-battery systems produce 2.9 tons and 5.8 tons of CO<sub>2</sub> per year, with renewable penetration rates of 0.95 (94%) and 0.87 (87%) respectively. However, the WT-DG-battery and DG-battery hybrid systems are not environment friendly, because of expected significant CO<sub>2</sub> emissions (34 tons and 40 tons per year, respectively), with renewable penetration rates of 0.16 (16%) and 0%, respectively.

### 3.2. Electricity production

Figs. 9 and 10 present monthly mean electricity production for the PV-WT-DG-battery and PV-DG-battery systems, respectively. The PV-WT-DG-battery optimum combination results indicate that the PV array, wind turbine and diesel generator, has 80%, 14% and 6% contribution for the total electricity production, with a total of 11% excess electricity, 4% unmet electricity and 6% capacity shortage. The PV-DG-battery optimum system shows that the PV array and diesel generator produce 87% and 13% electricity,

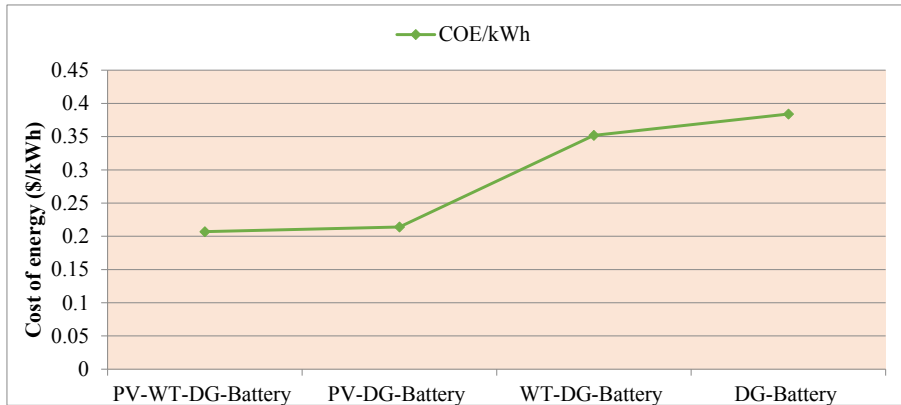

Fig. 7. Levelized cost of electricity for different optimal systems.

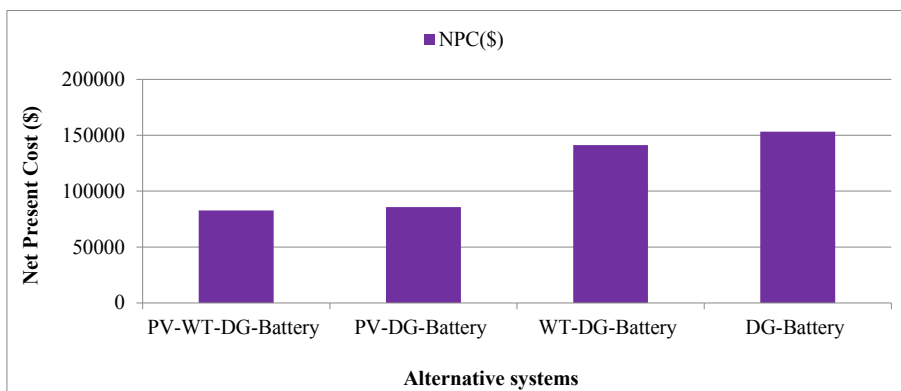

Fig. 8. Total net present cost for different hybrid systems.

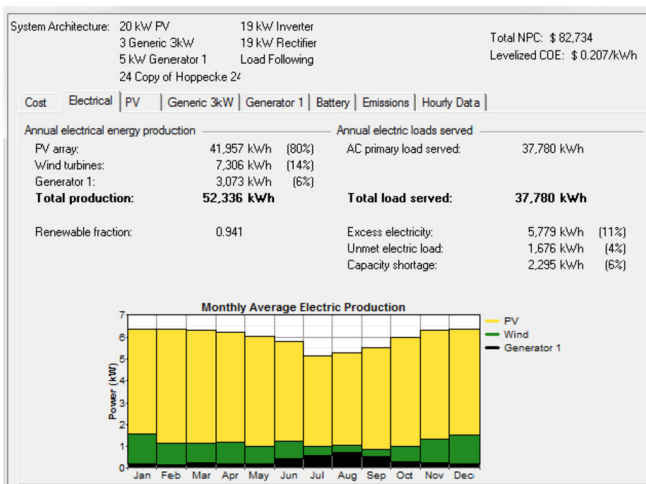

Fig. 9. Monthly electric production from the PV-WT-DG-battery optimal system.

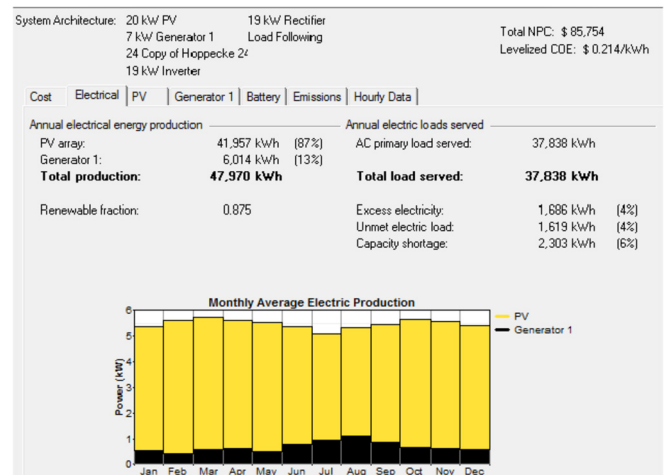

Fig. 10. Monthly electric production from the PV-DG-battery optimal system.

respectively, with an annual capacity shortage of 6%, excess electricity of 4% and unmet electricity of 4%.

Figs. 11 and 12 present AC daily primary load demand and supply options for the PV-WT-DG-battery and PV-DG-battery configurations, respectively, for the first week of January. In these systems, discharging and recharging of the battery depend on user demand and renewable energy production. The figures show that the batteries charge themselves and their power looks positive

during daytime due to energy production from solar PV. However, the overall load demand is significantly low means limited electricity use in daytime.

The battery power goes down when there is no production from solar PV. In both PV-WT-DG-battery and PV-DG-battery systems, the batteries are charged by solar PV and provide a great amount of electricity during night peak hours. Extreme shortage of power is shown in batteries in the early morning. The diesel generator helps

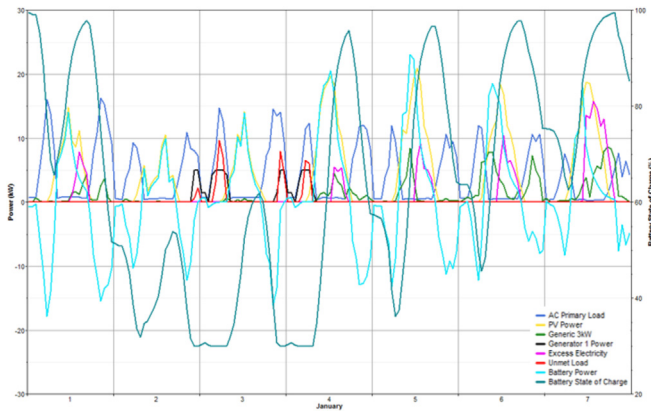

Fig. 11. Load demand and generation for the first week of January for PV-WT-DG-battery system.

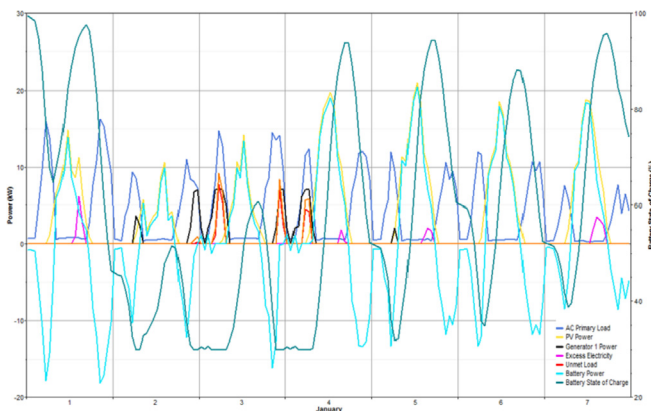

Fig. 12. Load demand and generation for the first week of January for PV-DG-battery system.

to meet the system peak demand.

### 3.3. Sensitivity results

The main advantage of sensitivity analysis is to analyze the effect of variability of key resource components and fuel prices on the total NPC of the generation mix and levelized COE. The key sensitive parameters considered in this study are diesel price values of USD 0.5, 0.6, 0.7, 0.8, 0.9, 1.0, 1.1 and 1.2 per liter, wind speeds of 1, 2, 3, 4, 5, 6.05, 7 and 8 m/s and solar radiation values of 0, 1, 2, 3, 4, 5 and 6.05 kWh/m<sup>2</sup>/day.

### 3.4. Sensitivity 1

Fig. 13 shows sensitivity results for variations in wind speed and diesel prices with a constant solar radiation value of 6.05 kWh/m<sup>2</sup>/day. In this scenario, it is observed that a small increase in wind speed can cause a significant reduction in NPC and levelized COE for all optimal systems. As clearly shown in Fig. 13, a wind-PV-DG-battery system becomes attractive for any diesel price and for a wide range of wind speeds within a range of 3.8–6 m/s, with a reasonably levelized COE from USD 0.168/kWh to USD 0.222/kWh. On the other hand, a Wind-PV-battery system becomes economically competitive only for a higher wind speed value (above 7 m/s) and a diesel price between USD 0.7 and USD 1.2 per liter. A PV-DG-battery system becomes economically feasible for any value of diesel price and wind-speed below 3 m/s. However, a wind-DG-

battery is economically feasible only within a small range of diesel prices near USD 0.5 per liter and for wind-speed greater than 7 m/s.

### 3.5. Sensitivity 2

Fig. 14 shows sensitivity results for a variation in solar radiation and diesel prices with a constant wind-speed value of 4 m/s. The figure shows that with any value of diesel prices and a solar radiation value greater than 3 kWh/m<sup>2</sup>/day, a wind-PV-DG-battery system becomes the most optimal and least-cost system with a COE of USD 0.209–0.382/kWh. However, a wind-DG-battery system becomes financially viable for all diesel prices and solar radiation of less than 1.5 kWh/m<sup>2</sup>/day.

## 4. Conclusions

This study identifies a representative village in Ethiopia for off-grid rural electrification considering three criteria. The first criterion was to identify areas with both solar and wind potential for off-grid electricity generation using NASA data. This assessment resulted in a large area of the country as there are many areas in Ethiopia with significant solar and wind potential. The second criterion was to identify a location that was sufficiently remote to not be reached by the electric grid but also sufficiently close to urban areas to support both on-farm and off-farm rural activities—reflecting the very rapid urbanization of Ethiopia and Sub-Saharan Africa. The third step was to identify a location where the local administration was supportive of a field study on off-grid electricity. Considering all these issues, Golbo II village was identified as a representative village in Ethiopia for off-grid rural electrification.

The study indicates that the selected study village, having a considerable annual average global solar radiation (5.23–6.57 kWh/m<sup>2</sup>/day) as well as substantial wind-speed (3.0–4.37 m/s), is a good prospective candidate for the deployment of a hybrid power system comprising solar photovoltaic (PV) array, wind turbines, a diesel generator and batteries. The simulation results indicate that the most economic, technical and reliable system for the off-grid system would be composed of a 20 kW solar PV array, three wind turbines (3 kW each), a 5 kW diesel generator, and 24 batteries (each with has a nominal voltage of 2 and capacity of 3000 Ah) for Golbo II village in Adaa district, Oromia Region, Ethiopia. Due to high diesel cost, power generation based solely on diesel with a battery storage system, is not economically viable.

This study also indicates that, generally, remote rural villages in Ethiopia are good candidates for the deployment of one of the proposed off-grid PV-diesel generator-battery hybrid systems for electricity generation, because of their favorable solar radiation and the fact that the diesel price is almost uniform throughout Ethiopia. Utilizing this hybrid system for electricity generation – compared with using only a diesel generator – would decrease operating hours and consequently the diesel consumption of the generators. The proposed system would help to reduce emissions of greenhouse gases, reduce dependency of imported diesel and enhance system reliability and affordability.

The cost of energy for the best-optimized system is USD 0.207/kWh. The NPC of the system is USD 82,734; initial capital costs are USD 48,497; diesel requirement is 1121 L per year; and the generator would operate for 882 h per year. The major share of electricity in the best optimal solution comes from solar PV, which provides power at low cost using free solar resources. The solar PV modules, wind turbines and diesel generator contribute 80%, 14%, and 6%, respectively, to electricity generation, with a renewable fraction of 96%.

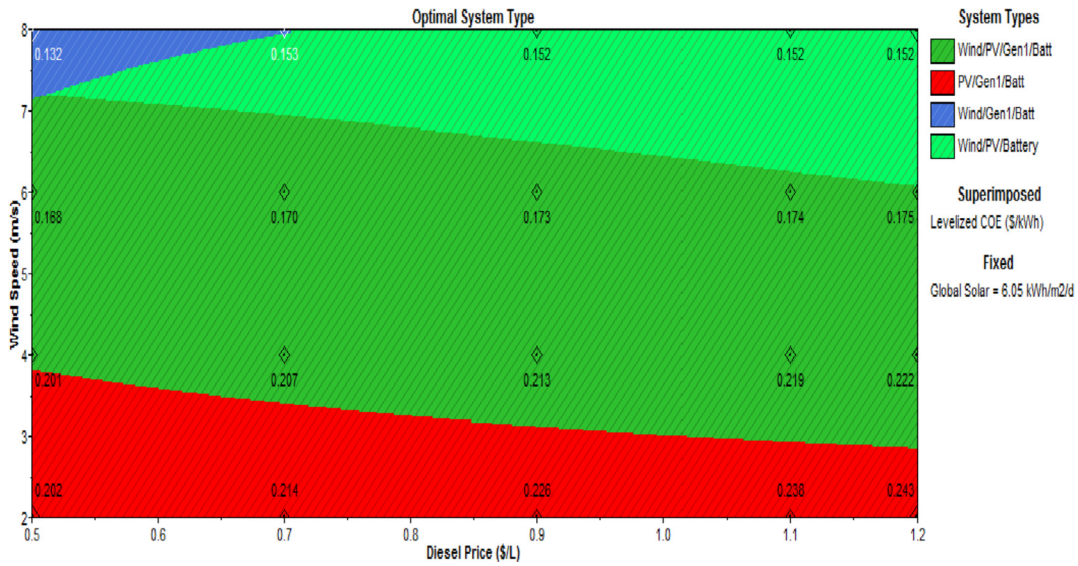

Fig. 13. Type of optimal systems in terms of wind-speed and diesel price with global solar radiation of 6.05 kWh/m<sup>2</sup>/day.

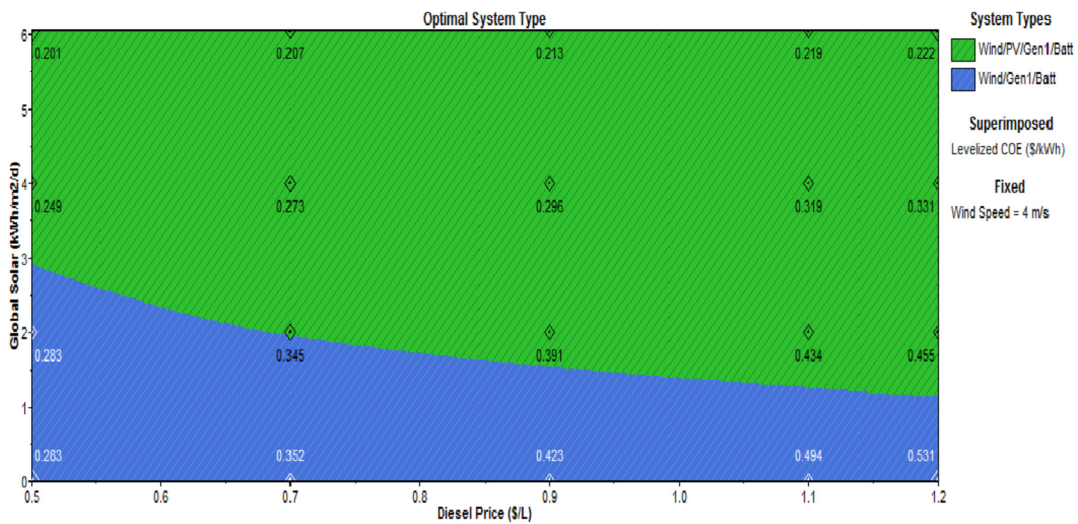

Fig. 14. Optimal systems in terms of solar radiation and diesel price with a constant wind-speed of 4 m/s.

Whilst there are political and socio-economic challenges to implementing off-grid hybrid system projects in rural Ethiopia, the benefits of electrification are important to improve the quality of life in such areas. Hybrid systems can play an important role in off-grid electrification, with their greater reliability and quality of service offered.

**Acknowledgement**

The International Food Policy Research Institute (IFPRI) and the Ministry of Water, Irrigation and Electricity (MoWIE), Ethiopia jointly assessed energy development pathways in Ethiopia with the financial support of the African Development Bank (AfDB), under the African Climate Technology and Finance Center and Network (ACTFCN), Enhance Knowledge and Technology Transfer for Mitigation and Adaptation in sub-Saharan Africa under the project titled “Alternative Pathways to Improve Electricity Access in Ethiopia”. The project was implemented under the umbrella of the CGIAR Research Program on Water, Land and Ecosystems (WLE).

**References**

- [1] UNDESA. United Nations, department of economic and social affairs (UNDESA), population division. “World population prospects: the 2017 revision, DVD Edition. 2017. 2017.
- [2] CSA. Ethiopia demographic and health survey 2011, central statistical agency (CSA), Addis Ababa, Ethiopia. 2012.
- [3] MoWE. Scaling - up renewable energy Program Ethiopia investment plan (draft final). Ministry of Water and Energy (MoWE), Ethiopia; 2012.
- [4] Mengistu MG, Simane B, Eshete G, Workneh TS. A review on biogas technology and its contributions to sustainable rural livelihood in Ethiopia. *Renew Sustain Energy Rev* 2015;48:306–16.
- [5] CSA. Welfare monitoring survey 2011: indicators on living standard, accessibility and household assets, statistical report, central statistical authority (CSA), Addis Ababa, Ethiopia. 2012.
- [6] MoFED. Growth and transformation plan (GTP) 2010/11-2014/15. ”: Ministry of Finance and Economic Development (MoFED); 2010.
- [7] Seboka MD. Ethiopian energy status, challenges and opportunities . Presented at stakeholders workshop on alternative pathways to improve electricity access in Ethiopia on november 28, 2017, Addis Ababa, Ethiopia. 2017.
- [8] NPC. Growth and transformation plan II (GTP II) (2015/16-2019/20), national planning commission (NPC), Ethiopia. 2016.
- [9] Mondal MAH, Bryan E, Ringler C, Mekonnen D, Rosegrant M. Ethiopian energy status and demand scenarios: prospects to improve energy efficiency and mitigate GHG emissions. *Energy* 2018;149:161–72.

- [10] MoWIE. Energy balance and statistics for years 2005/06 - 2010/11. Ministry of Water, Irrigation and Energy (MOWIE); 2012.
- [11] IEA. IEA energy statistics, International energy agency (IEA). 2016. Paris, France.
- [12] FDRE. Ethiopia's climate-resilient green economy: green economy strategy, federal democratic Republic of Ethiopia. ": FDRE; 2011.
- [13] MoWIE. Updated rapid assessment and gap analysis on sustainable energy for all (SE4All): the UN secretary general initiative. ": Ministry of Water, Irrigation and Energy (MoWIE); 2013.
- [14] Nandi SK, Ghosh HR. Prospect of wind-PV-battery hybrid power system as an alternative to grid extension in Bangladesh. *Energy* 2010;35(7):3040–7.
- [15] Nema P, Nema RK, Rangnekar S. A current and future state of art development of hybrid energy system using wind and PV-solar: a review. *Renew Sustain Energy Rev* 2009;13(8):2096–103.
- [16] Neves D, Silva CA, Connors S. Design and implementation of hybrid renewable energy systems on micro-communities: a review on case studies. *Renew Sustain Energy Rev* 2014;31:935–46.
- [17] Jacobus H, Lin B, Jimmy DH, Ansumana R, Malanoski AP, Stenger D. Evaluating the impact of adding energy storage on the performance of a hybrid power system. *Energy Convers Manag* 2011;52(7):2604–10.
- [18] Drake F, Mulugetta F. Assessment of solar and wind energy in Ethiopia: I. Wind energy. *Sol Energy* 1996;57(3):205–17.
- [19] Mulugetta Y, Drake F. Assessment of solar and wind energy resources in Ethiopia: II . Solar energy. *Sol Energy* 1996;57(4):323–34.
- [20] DRL. Solar and Wind Energy Resource Assessment (SWERA): high Resolution Solar Radiation Assessment for Ethiopia. Deutsches Zentrum für Luft- und Raumfahrt. D-70569 Stuttgart, Germany: DLR-Stuttgart, Institut für Technische Thermodynamik; 2004. Pfaffenwaldring 38-40.
- [21] Abraha AH, Kahsay MB, Kimambo CZM. Hybrid solar – wind – diesel systems for rural application in North Ethiopia: case study for three rural villages using HOMER simulation. *Momona Ethiop J Sci* 2013;5(2):62–80.
- [22] Bekele G. Study into the potential and feasibility of a standalone solar-wind hybrid electric energy supply system: for application in Ethiopia ph.D Dissertation. Stockholm, Sweden: Royal Institute of technology (KTH); 2009.
- [23] Bekele G, Palm B. Feasibility study for a standalone solar-wind-based hybrid energy system for application in Ethiopia. *Appl Energy* February 2010;87(2): 487–95.
- [24] Bekele G, Boneya G. Design of a photovoltaic-wind hybrid power generation system for Ethiopian remote area. *Energy Proc.* 2012;14:1760–5.
- [25] B. G. Modeling and simulating of a micro hydro wind hybrid power generation system for rural area of Ethiopia. Mater thesis in Addis Ababa University.; 2013.
- [26] Rajbongshi R, Borgohain D, Mahapatra S. Optimization of PV-biomass-diesel and grid base hybrid energy systems for rural electrification by using HOMER. *Energy* 1 May 2017;126:461–74.
- [27] Rahman MM, Khan MMUH, Ullah MA, Zhang X, Kumar A. A hybrid renewable energy system for a North American off-grid community. *Energy* 15 February 2016;97:151–60.
- [28] Rohani G, Nour M. Techno-economical analysis of stand-alone hybrid renewable power system for Ras Musherib in United Arab Emirates. *Energy* 1 January 2014;64:828–41.
- [29] Alemayehu N, Hoekstra D, Berhe K, Jaleta M. Irrigated vegetables promotion and expansion: the case of Ada district, Oromia, Ethiopia. 2010.
- [30] Mekonnen D, Bryan E, Alemu T, Ringler C. Food versus fuel: examining tradeoffs in the allocation of biomass energy sources to domestic and productive uses in Ethiopia, agricultural and applied economics association. In: 2015 AAEA & WAEA joint annual meeting, July 26–28, San Francisco, California; 2015.
- [31] Mondal AH, Denich M. Hybrid systems for decentralized power generation in Bangladesh. *Energy Sustain Dev* 2010;14(1):48–55.
- [32] Das BK, Hoque N, Mandal S, Pal TK, Raihan MA. A techno-economic feasibility of a stand-alone hybrid power generation for remote area application in Bangladesh. *Energy* 2017;134:775–88.
- [33] IECOPNOMICS. Ethiopia interest rate. IECOPNOMICS; 2018. Available at: <https://ieconomics.com/ethiopia-interest-rate>.
- [34] Barley CD, Winn CB. Optimal dispatch strategy in remote hybrid power systems. *Sol Energy* 1996;58(4–6):165–79.