

Technical Note:**DEVELOPMENT OF A CHISEL DIGGER
FOR HARVESTING GROUNDNUT****N. K. Awadhwal, T. Takenaga and M. M. Babu¹****ABSTRACT**

A chisel digger was designed and developed at ICRISAT Asia Center for harvesting virginia bunch type groundnut crops. It consists of a digger-bottom and a standard. The digger-bottom has two shares that are inclined at 120° to each other and contain chisel points for increased penetration into the soil. A single digger-bottom attached to a draw pole can be pulled by a pair of oxen and two or more digger-bottoms attached to a tool bar can be pulled by a tractor. The bullock-drawn chisel digger can harvest a 60-cm wide strip or two rows of the crop sown at a 30-cm row spacing. It can harvest about 0.7 ha per day (8 h) with less than 5% losses. It undercuts the tap roots of groundnut plants and leaves the plants upright without any dragging. The chisel digger performed satisfactorily even under soil conditions where blade type diggers could not penetrate up-to the desired depth.

1. INTRODUCTION

Groundnut (*Arachis hypogea* L.) is primarily grown under rainfed dryland conditions and about 67% of the total world production comes from areas of the semi-arid tropics (SAT). It ranks either second or third among the annual oilseed crops grown in many countries of the Asian SAT, including Bangladesh, Bhutan, Myanmar, Nepal, Pakistan, and Sri Lanka (Reddy et al., 1991).

It is important to harvest the crop at the optimum time, so that the maximum yield of best quality pods with high shelling percentage, oil content, and high seed mass are obtained. The moisture content of the soil influences the ease of harvesting groundnut. In the SAT regions, drought stress during the late stage of pod development is a common occurrence. Under such drought conditions most of the soils, except sandy soils, become hard contributing to harvesting problems.

Most of the small scale farmers manually harvest groundnut crop, by pulling out plants at the time of maturity. They use bullock-drawn hoes and blade harrows to dig

1. Senior Scientist, Principal Agricultural Engineer (until 1988), and Research Associate II, Soil and Agro-climatology Division, ICRISAT. P.O. Patancheru 502 324 (A.P.) India.

groundnut, when manual harvesting becomes difficult due to lack of sufficient soil moisture. Under hard-soil conditions these implements can not penetrate up to desired depth (about 8 cm) and do not perform satisfactorily. At some research institutions a few designs of groundnut digger have been developed (Ali et al., 1979), mainly to reduce draft and clogging of plants. These diggers are essentially variations of the blade harrow, having different sizes of the cutting blade with different curvatures. These diggers perform a little better than the traditional harrows (Savani et al., 1983). Development of an efficient groundnut digging implement for small farmers still remains an important research priority (Reddy et al., 1991).

2. MATERIAL AND METHODS

2.1 Design Criteria

Performance of a soil working tool depends upon its shape, orientation during movement, and initial soil conditions. The draft force of a soil working tool is directly proportional to the tool width and increases exponentially with operating depth (Grisso et al., 1980; Godwin and Spoor 1977). Researchers in the past have reported effects of tool geometry (Fig. 1) and orientation on tool performance for several agricultural soils under different operating conditions (Gill and Vanden Berg, 1967). Kawamura (1952) reported that for shallow tillage tools minimum draft occurred at a lift angle of about 25°, and Payne (1956) showed that draft of a 10-cm wide chisel was minimum at 20°. Chase (1942) studied the lift angle of tiller blades and noted that a low lift angle (16°) accentuated soil cutting and higher lift angles accentuated the upheaval of soil around the tool. Soil shattering was satisfactory only when the soil was dry and brittle and a lift angle of 35° was found optimum for this purpose. Kaburaki and Kisu (1959) observed that an increase in side angle decreased draft until an angle of about 40° was attained. In case of tools designed to cut plant roots, the blades are swept back at an angle between 20° and 50° to increase cutting effectiveness and permit self-cleansing of blades (Hardy, 1938). Penetration of tillage tools is determined by its suction. The suction has an inherent relationship with approach angle of the tool shank, and can be altered by changing inclination of the shank through the hitch point (Bainer et al., 1972).

2.2 Design and Construction

Based on the above design information, a groundnut digger was designed to meet the following functional requirements. The digger should cut the tap roots at the desired depth without dragging the plants and should loosen the soil sufficiently to permit lifting of plants, detaching a minimum number of pods. The digger should work well under soil conditions where blade type diggers can not penetrate adequately.

The chisel digger consists of a digger-bottom and a standard. The digger-bottom

has two shares that are swept back by 30° to make an angle of 120° with each other. The digger-bottom has a suction angle of 3.8° . Five small chisels are provided on each share to enhance penetration into hard soils. The chisels have clearance angle of 11° , lift angle of 17° , and side angle of 30° . Design of the chisel digger is shown in Figs. 2 and 3. The digger-bottom components (including shares and chisels) are made of carbon steel (EN8) and heat treated to Brinell Hardness Number (BHN) 401. A single digger-bottom attached to a toolbar can be pulled by a pair of oxen and two or more digger-bottoms can be pulled by a tractor (Fig. 4). Specifications of the animal drawn chisel digger are given in Table 1.

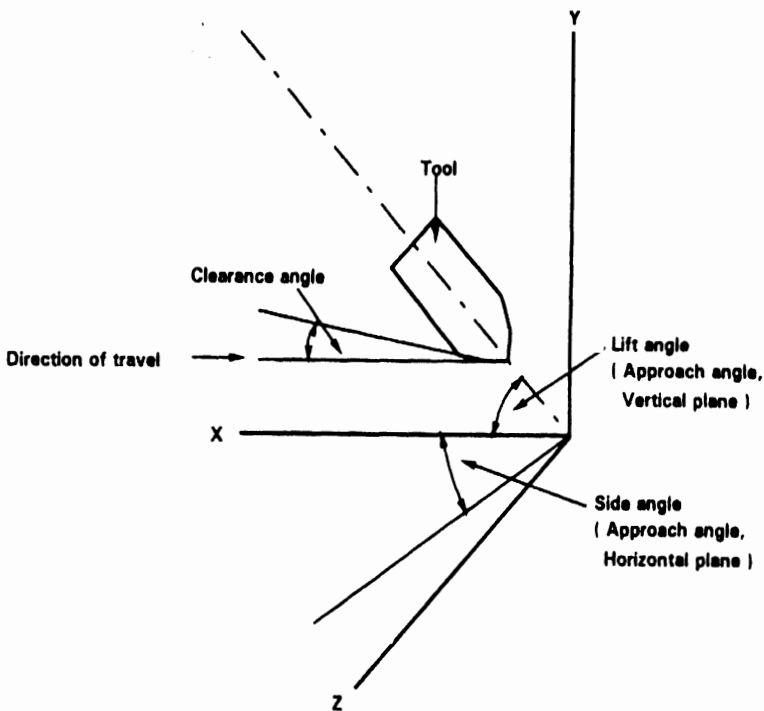

Fig. 1 : Geometry and orientation angles of a tillage tool

Table 1 : Specifications

Type	Animal drawn
Power source	A pair of bullock
Mass of digger	9 kg
Mass of draw pole	16 kg
Maximum width of digging	600 mm
Maximum depth of digging	200 mm

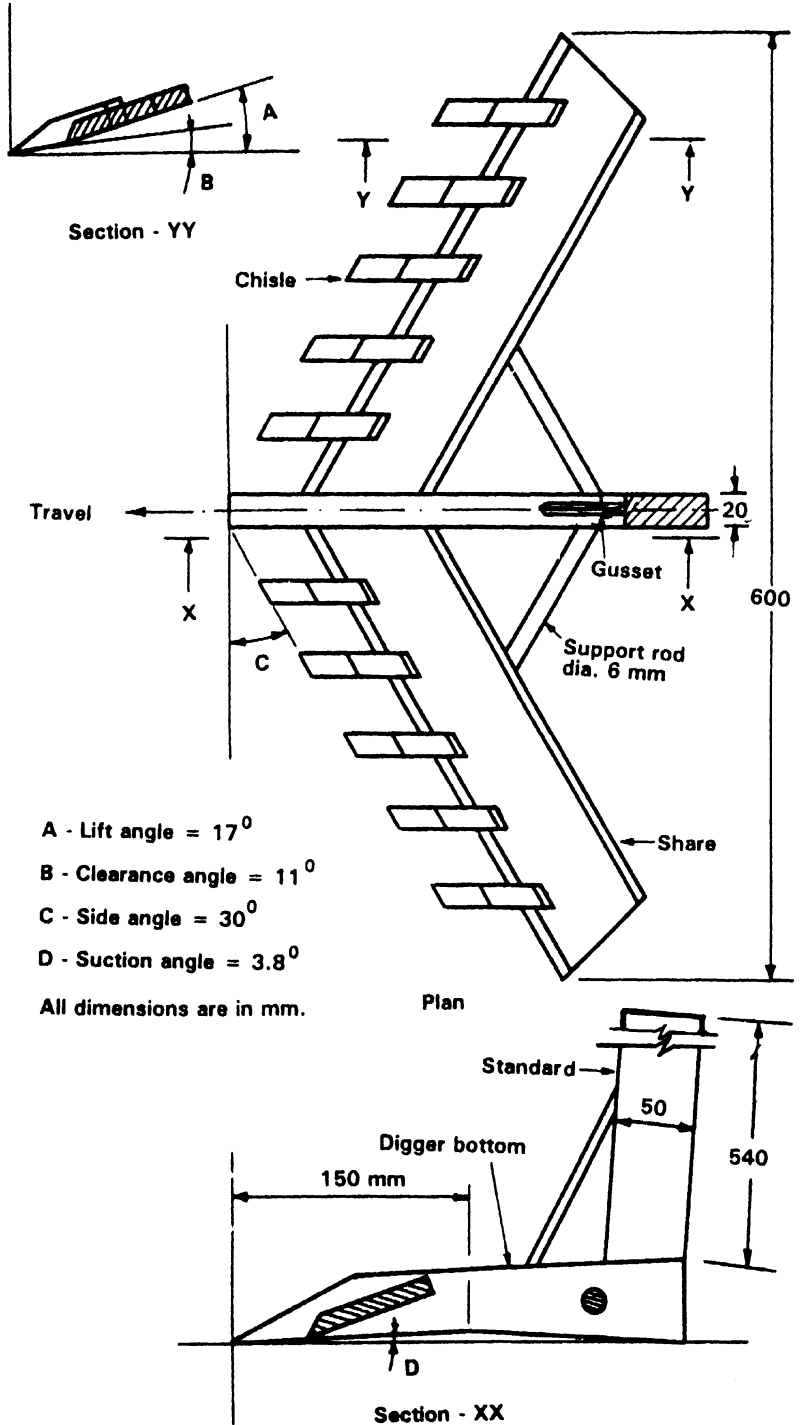
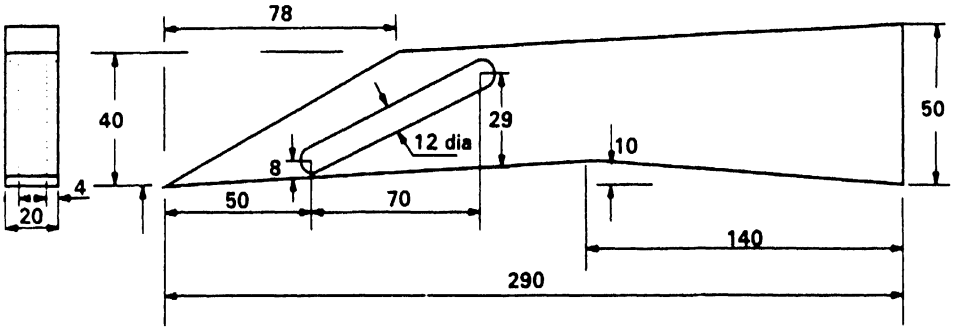
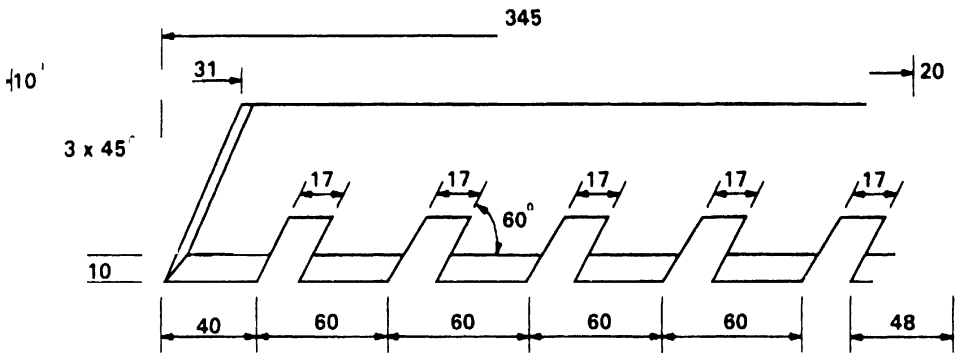

Fig. 2 : Design details of a chisel digger



Digger bottom



Share
(1 LH + 1 RH)

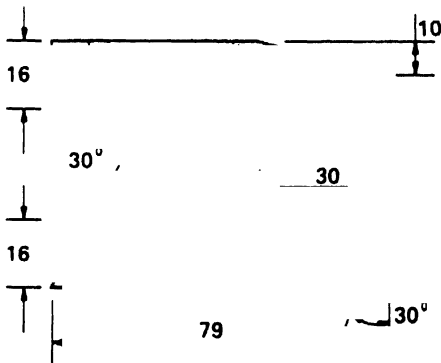

Chisel

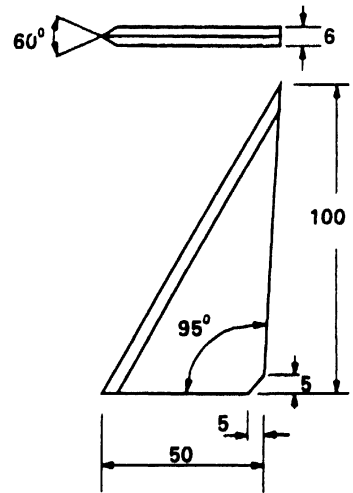

Gusset

All dimensions are in mm.

Fig. 3: Design details of digger bottom components

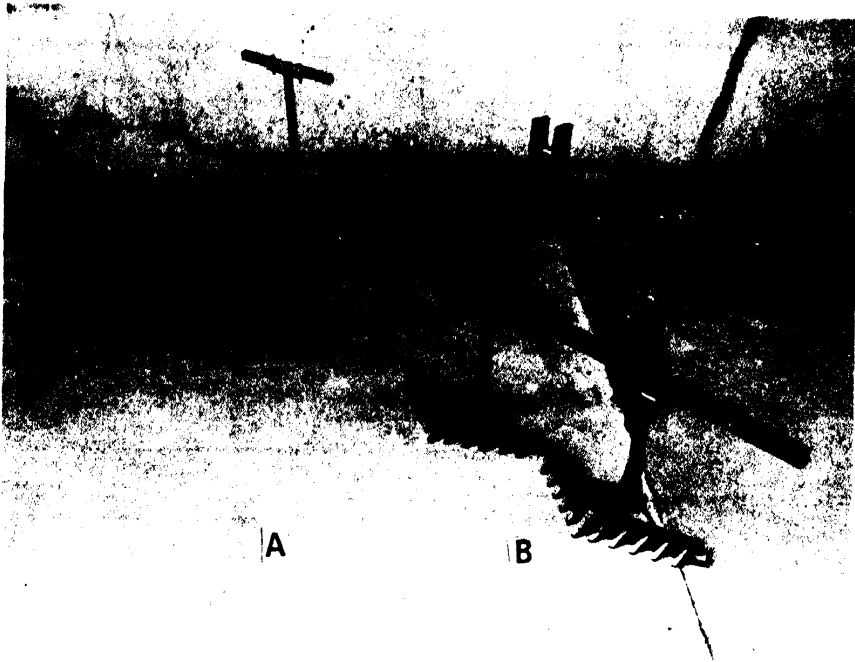

Fig. 4: The chisel digger for harvesting groundnut (A: Animal drawn; B: Tractor drawn)

2.3 Performance Test

Animal-drawn chisel digger and a 60 cm wide blade type digger were tested for digging Virginia bunch type groundnut in sandy loam Alfisol (sand 54.7%, silt 27.3%, clay 18%) fields under different soil moisture conditions. The diggers were tested in wet soil conditions suitable for manual harvesting of groundnut to compare the harvesting losses of these implements with manual harvesting method. Experiments were conducted in a randomized-block design with 4 replications to harvest groundnut under drying soil conditions where gravimetric moisture content (m.c.) of soil on dry basis varied from 9% to 4%. Draft requirement, depth of penetration and the harvesting losses were recorded for both the chisel and the blade type diggers. Draft of the diggers was measured with a strain gauge dynamometer (Novatech) and recorded in a data logger (Campbell CR 21X). Depth of penetration of the digger was measured by removing the loose soil from a dug row and measuring the depth of the furrow-bottom with reference to the adjoining undisturbed soil surface. The cone index (CI) of soil was measured with a cone penetrometer (base area 5 cm²) over a depth of 5 cm. The chisel digger and blade type digger were operated in a groundnut field (area 1.2 ha) under similar soil conditions during two successive years and the draft requirement and harvesting losses were recorded for both the diggers.

Tractor mounted units of the chisel digger and a 1.2 m blade type digger were operated in drier soil conditions (m.c. 3-4% and CI 0.98-1.47 MPa) to compare their performance.

3. RESULTS AND DISCUSSION

Results from field tests show that in wet soil (m.c. 13%, SE \pm 0.41) where manual digging was feasible, the mean draft requirements of the chisel digger (931 N) and the blade type digger (882 N) did not differ significantly ($P < 0.05$) and manual digging required about 176 man-h (SE \pm 31.95) to cover 1 ha. The harvesting losses were 1.5% for the chisel digger, 2.2% for blade digger and 1.2% for manual digging. The differences in the harvesting losses were not significant ($P < 0.05$).

In friable soil conditions (m.c. 9% SE \pm 0.21 and CI 147 kPa, SE \pm 31.3) the mean draft requirement for the chisel digger (823 N) and the blade digger (882 N) did not differ significantly but the harvesting losses for the blade digger (6.4%) were significantly ($P < 0.05$) higher compared to the chisel digger (3.2%). Time required to cover 1 ha for the animal-drawn chisel digger (11.2 h SE \pm 2.45) and the animal-drawn blade digger (11.7 h SE \pm 1.55) did not differ significantly. The average work rate of the diggers was about 0.7 ha per day (8 h).

In a moderately dry soil (m.c. 5.5%, SE \pm 0.25 and CI 529 kPa, SE \pm 30.4) the chisel digger required a draft of 1137 N and the blade required 1441 N. The harvesting losses were 3.6% for the chisel digger and 7.4 % for the blade digger. The draft as well as the harvesting losses for the blade digger were significantly higher ($P < 0.05$) than the chisel digger. The average depth of penetration of the diggers was 8 cm (SE \pm 0.6) in moderately dry soil and 10 cm (SE \pm 0.8) in wet soil.

Under the dry and hard soil conditions (CI 0.78-1.07 MPa), the draft required per unit depth of penetration for the chisel digger was significantly lower ($P < 0.05$) than the blade digger (Fig. 5). The harvesting losses were also significantly lower ($P < 0.05$) for the chisel digger compared to the blade digger (Fig. 6) and the losses increased with increase in draft requirement for both the diggers. In dry soil where the surface soil strength exceeded 0.98 MPa the blade type digger could not penetrate deeper than 5 cm but the chisel digger satisfactorily performed operations with a penetration of about 8 cm. The difference in performance of the diggers is due to the tool geometry of the chisel digger, which enables deep penetration and effective break-up of even hard soil.

Field tests of the tractor-mounted chisel digger and the blade digger in dry and hard soil conditions (CI 0.98-1.47 MPa), show that the harvesting losses in case of the blade digger (19%) were significantly higher ($P < 0.05$) than those from the chisel digger (12%). The diggers operated at a depth of about 8 cm. It was also noted that the blade digger was prone to clogging with vegetative material and required cleaning at least twice in a 100 m length of run, whereas the chisel digger did not clog. The blade digger also required about 150 kg additional mass on top of its toolbar for proper penetration

into soil but no additional weight was needed for the chisel digger. The tractor-drawn units of both the digger covered 0.45 ha (SE \pm 0.054) in an hour.

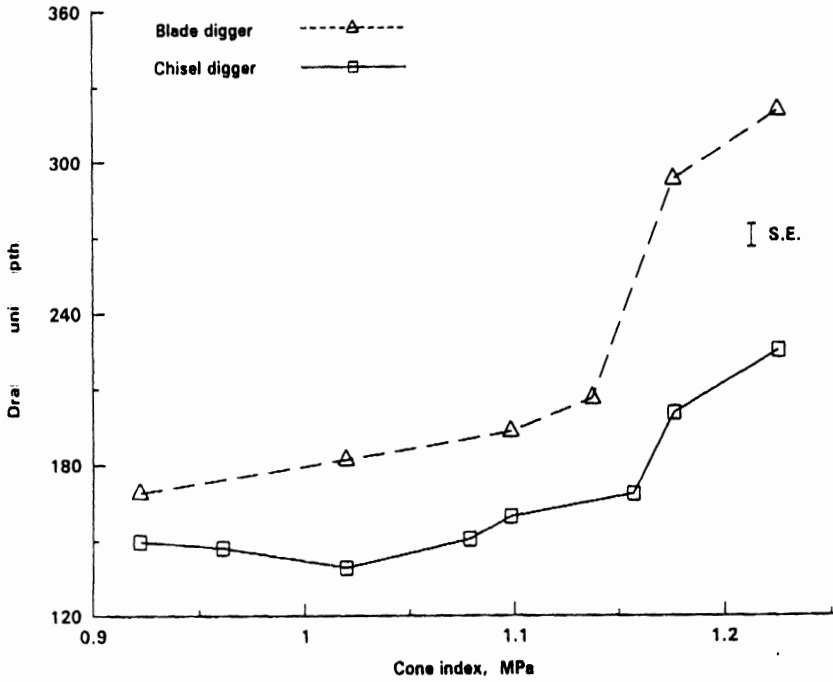

Fig. 5 : Effect of soil strength on draft of animal drawn diggers

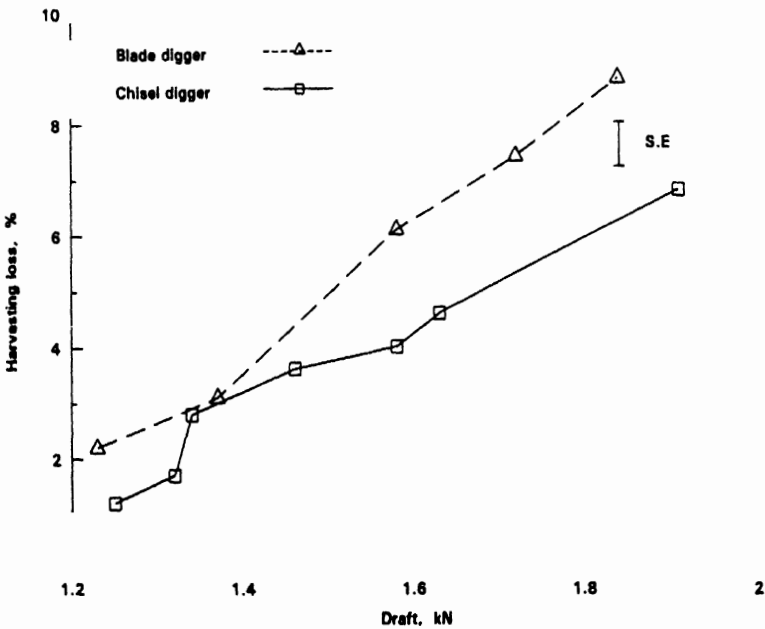

Fig. 6 : Harvesting losses and draft of animal drawn groundnut diggers

4. CONCLUSIONS

The animal-drawn chisel digger satisfactorily performed its operation even in hard soil (CI up to 0.98 MPa) while a blade type digger could not (penetration less than 5 cm). The chisel type digger undercuts the main root of groundnut plants, leaving the plants upright. The plants could then be manually lifted without any problem of pod-soil separation as the digger loosened the soil sufficiently. A single digger-bottom can be pulled by a pair of bullocks and covers a 60 cm strip or two rows of the crop planted at a row spacing of 30 cm. The harvesting losses were less than 5% and the average field capacity of the chisel digger was 0.7 ha/day.

REFERENCES

1. Ali, N., Patra, S.K. and R. Lall (1979). Catalogue of improved agricultural implements and equipment of India. Central Inst. of Agric. Eng., India.
2. Bainer, R., Kepner, R.A. and E.L. Barger (1972). Principles of farm machinery. AVI. New York. pp 170-187.
3. Chase, L.W. (1942). A study of subsurface tillage blades. *Agricultural Engineering*, 23(1): 43-50.
4. Gill, W.R., and G.E. Vanden Berg (1967). Soil dynamics in tillage and traction. USDA Handbook No. 316. USDA, Washington. pp. 255-258.
5. Godwin, R.J. and G. Spoor (1977). Soil failure with narrow lines. *J. Agric. Engng. Res.*, 2(3): 213-226.
6. Grisso, R.D., Perumpal, J.V. and C.S. Desai (1980). A soil-tool interaction model for narrow tillage tools. ASAE winter meeting, Paper No. 80-518. American Society of Agricultural Engineers, Michigan.
7. Hardy, E.A. (1938). Tillage in relation to weed root systems. *Agricultural Engineering*, 19: 435-438.
8. Kaburaki, H. and M. Kisu (1959). Studies on cutting characteristics of ploughs. Translation No. 79. National Institute of Agricultural Engineering (USA).
9. Kawamura, N. (1952). Study on soil cutting and pulverization. *Soc. Agr. Mach. J. (Japan)*, 14(3): 65-71.
10. Payne, P.C.J. (1956). The relationship between rake angle and the performance of simple cultivation implements. *J. Agric. Engng. Res.*, 4: 312-325.
11. Reddy, P.S., Basu, M.S., Khaleque, M.A., Hoque, M.S., Ali, N., Malik, S.N., Than, H., Soe, T., Regunathan, N., Mishra, B., Murthy, T.G.K., and S.N. Nigam (1991). Status of groundnut research and production in South Asia. Pages 133-147. In: *Groundnut - A global perspective*. Proceedings of an International Workshop. 25-29 Nov 1991. ICRISAT Center, Patancheru, India.
12. Savani, J.B., Memon, A.H., Singh, P.M., and L. P. Singh (1983). Development and evaluation of a bullock drawn groundnut digger. ISAE Paper No. 83-1402. Indian Society of Agricultural Engineers (ISAE), New Delhi, India.