

Agronomic Practices for Experimentation

Compiled by

S.K. Dasgupta and D.L. Oswalt



Skill Development Series no. 2

(Revised July 1992)



ICRISAT

Human Resource Development Program

**International Crops Research Institute for the Semi-Arid Tropics
Patancheru, Andhra Pradesh 502 324, India**

1992

Contents

A. Area, Rectangle, and Slope	5
Formation of a Rectangle	5
Estimation of the Area of a Field	8
Calculating a Slope	9
B. Soil Sampling Procedures and Preparation of Samples	11
C. Layout	14
Laying Out an Experiment	14
Example of an Experimental Plan	15
D. Fertilizers	19
Definition and Characteristics	19
Analysis or Grade of Fertilizers	19
Mixing and Storage of Fertilizers	20
Fertilizer Calibration	21
Fertilizer Application	23
E. Seed Calibration and Sowing	25
Estimation of the Seed Required for Sowing	25
Establishing the Required Plant Population	25
Packeting of Seed for Sowing	26
Seed Packeting for Machine Sowing	27
Hand-sowing Procedure	28
Sowing by Machine	30
Sowing in Different Soil Types	32
Filling of Gaps After Germination	32
F. Crust Breaking on Alfisols	33
G. Harvesting of Experimental Crops	36
H. Evaluations	38

A. Area, Rectangle, and Slope

Formation of a Rectangle

Experiments are usually laid out in square or rectangular plots for data and yield estimation, even though the field may be irregular. The plot is usually placed on the contour, parallel with a road, or in a north-and-south alignment. To mark a plot, construct a right angle and then form a rectangle or square.

Procedure

1. The Pythagorean theorem states that the square of the hypotenuse of a right-angle triangle is equal to the sum of the squares of the two sides.

2. Figure 1 shows a right-angle triangle with the sides AB (3 cm), BC (4

cm), and the hypotenuse AC (5 cm). The sides are multiples of 3, 4, and 5. The sides $AB^2 + BC^2$ are equal to AC^2 or $(3 \times 3) + (4 \times 4) = (5 \times 5)$ when the angle at B is a right angle (90 degrees).

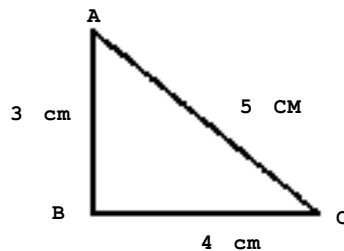

Figure 1. Right-angle triangle.

3. Therefore, a right-angle triangle can be formed by taking multiples of 3, 4, and 5 such as 6, 8, and 10; 9, 12, and 15; or 12, 16, and 20.

4. Set pegs at A and B to make a base line and then mark off 3 m as the base line. This will be the base AB (Fig. 2) of a triangle ABC.

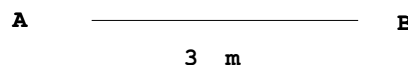

Figure 2. Base line of triangle.

5. Using a measuring tape, mark an arc with a radius of 4 m at an approximate right angle from point A (Fig. 3).

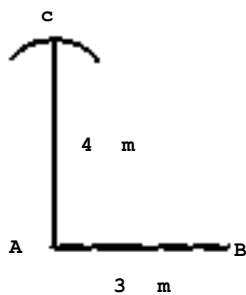

Figure 3. An approximate right angle with two sides.

6. Again, using the measuring tape, mark an arc from point B with a radius of 5 m so that it will intersect the previous arc from point A (Fig. 4).

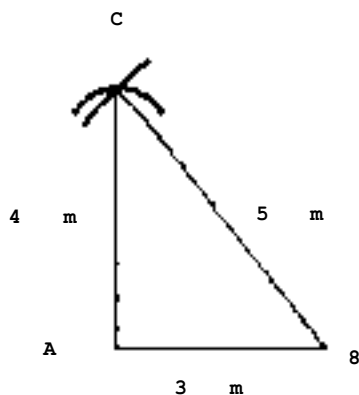

Figure 4. Forming a right-angle triangle.

7. Place the stake C at the point of intersection.

8. Now standing at A, we have a right-angle triangle with a base AB (3 m), side AC (4 m), and hypotenuse BC (5m).

9. Using the eye, extend the line AC to D. AD will be measured to equal 5 m or the length of the side of a rectangular plot (Fig. 5).



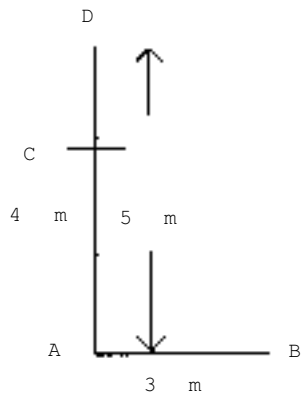

Figure 5. Forming the side of a rectangle.

10. Next, form an arc at an approximate right angle with a 3-m radius from point D (Fig. 6).

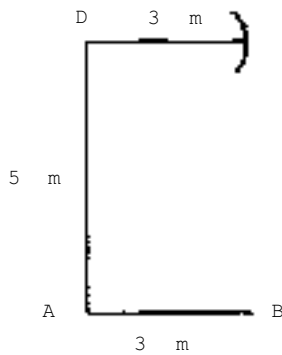

Figure 6. Forming three sides of a rectangle.

11. Form another arc with a 5-m radius from B to intersect the previous arc from point D. Place a stake at their intersection and mark it E (Fig. 7).

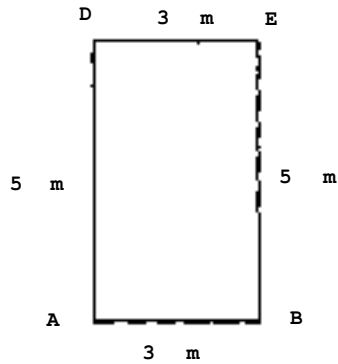

Figure 7. A rectangle of 5 m x 3 m.

Now a rectangle ABED is formed with sides 5 m and 3 m.
 Note: AD and BE = 5 m and AB and DE = 3 m.

12. If the four sides and the angle at A have been measured accurately the angles at A, B, D, and E are 90° and the diagonals AE and BD (Fig. 8) will be equal (in this example, 5.83 m).

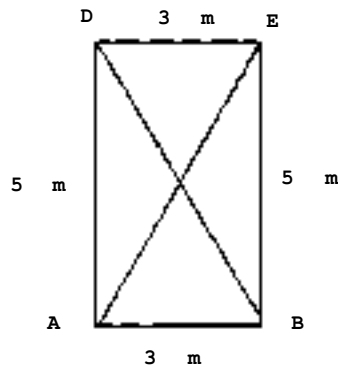

Figure 8. Measuring the diagonals of a rectangle.

Estimation of the area of a field

The area of a given field can be roughly estimated without using survey instruments. Ability to estimate the area of the given field will help the scientist to select a suitable area for his experimentation or demonstration.

To be able to estimate linear distances one should know the length of one's average pace.



Procedure

Place two stakes 30 m apart on a level surface. This distance of 30 m is paced with a normal stride counting the number of paces, repeating (three to four times in each direction) until the number of paces is nearly the same. One should hold one's hands behind the back to ensure an even stride. To find the average length of a pace, the distance is divided by the average number of paces.

Example

If 42 paces were required to cover 30 m, then:

$$\text{Each pace} = \frac{30 \text{ m}}{42 \text{ paces}} = 0.71 \text{ m pace}^{-1}$$

The area of a plot or field can now be estimated by finding the number of paces for two adjoining sides of the field, such as sides AB and BC (Fig. 9). In this example, side AB was 266 paces and side BC 401 paces. Now convert the data from paces to meters.

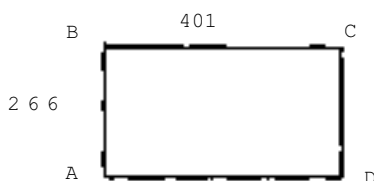

Figure 9. Area of a field measured in paces.

The length of the sides of the field will be:

$$401 \text{ paces} \times 0.71 \text{ m pace}^{-1} = 284.71 \text{ m}$$

$$266 \text{ paces} \times 0.71 \text{ m pace}^{-1} = 188.86 \text{ m}$$

Therefore, the area of the field will be:

$$284.71 \text{ m} \times 188.86 \text{ m} = 53770 \text{ m}^2 \text{ or } 5.37 \text{ ha.}$$

Thus, by this method one can estimate the area of a field. But, as has been shown, it is essential that one knows the average length of one's pace.

Calculating a Slope

Slope determines the natural surface drainage of water in a field. The amount of slope will cause the water to flow at a faster or at a slower rate. An understanding of slope will help in identifying soil conservation practices for reducing soil erosion, increasing water infiltration, and controlling drainage.

Slope represents the difference in elevation between two points. It is estimated as the proportion of the rise or fall to the horizontal distance between two points. Slope is expressed as a percentage (0.1%, 0.5%, 1.0%, 5%).

Slopes can be measured precisely by using a survey instrument, like the 'Dumpy level', which creates a vision of a horizontal line from which measurements are taken to the soil surface for a measured distance. But slopes can also be estimated by using stakes, a measuring tape, a carpenter's level, and a 2-m pole (Fig. 10.)

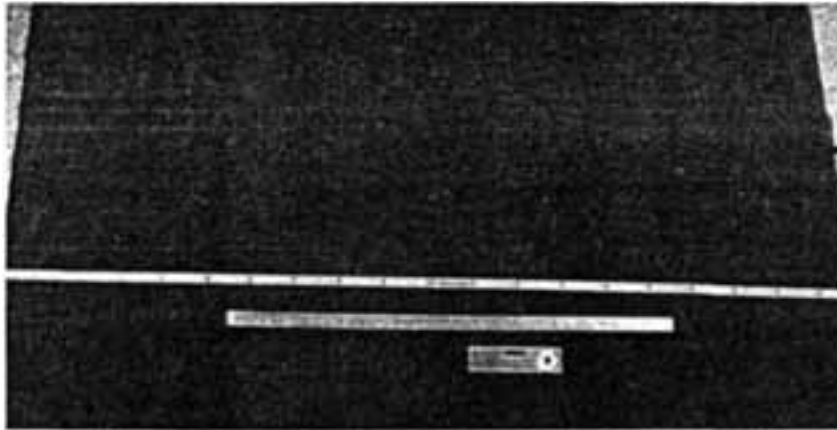

Figure 10. Carpenter's level and meter sticks.

Procedure

Place two stakes on a slope one at the higher elevation and one at the lower elevation of the slope to be determined. Measure the horizontal distance between stakes 'A' and 'B' with the help of a carpenter's level and a measuring tape. Now, with a carpenter's level at the lower level (stake B), move upwards along the pole set at stake B until your eye-line is level with the base of stake A. When you can see horizontally the base of stake A, measure this height on the pole set at B (Fig. 11).

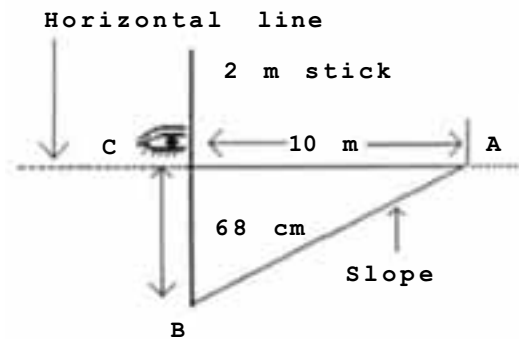

Figure 11. Calculating slope.

Suppose this height (BC) is 68 cm then, the percent slope will be the proportion of the vertical distance between B and C to the horizontal distance AC. Thus 68 cm is divided by 10 m and multiplied by 100, or $BC/AC \times 100$.

Therefore, the slope from A to B is:

$$\frac{0.68 \text{ m} \times 100\%}{10 \text{ m}} = 6.8\%$$

Slope is an essential factor in determining the layout of surface drainage (broadbed-and-furrow systems, furrows, and ridges) and irrigation channels on all fields. Normally the slope may range between 0.2% and 0.8% for experimental plots.

B. Soil Sampling Procedures and Preparation of Samples

Purposes of Sampling

Some of the important objectives of soil sampling are:

1. To study the physical characteristics of the soil, such as, texture, structure, and moisture content.
2. To study the chemical status of the soil, such as, presence of nutrients and salts; to know whether a soil has adequate plant nutrients and is acidic, saline, or alkaline.
3. To study the microbiological status of the soil or the presence of various kinds of microorganisms, in the soil.

Requirements of a Composite Sampling Procedure

The fundamental requirements of valid composite sampling are:

1. The soil unit selected for one composite sample should be homogeneous on the basis of color, texture, previous fertilizer treatment, management, and cropping pattern.
2. Each core or subsample should be of the same volume and represent a similar soil.
3. The subsamples should be taken at random with respect to the sampling area, usually across the direction of cultural operations and natural trends of change, such as slope. Avoid regions of farmyard manure, fertilizer bands, and chemical bands.

Sampling Tools (Figs. 12 and 13)

1. Knife, for sampling profile horizons.
2. Spade, for sampling surface soil.
3. Trowel or scoop, for sampling horizons of a profile.
4. Core sampler, for rapid sampling of a plow layer.
5. Augers, for sampling a deep soil.
 - a. Screw auger or carpenter's auger.
 - b. Tube auger or Veihmeyer tube.
 - c. Post-hole auger.
6. Shovels, for sampling surface soil.

Sampling Accuracy Depends Upon the Use of the Tools

1. The tools should be clean, rust resistant, and durably constructed to resist bending or breakage.
2. Take enough soil from each sampled area so that the composite sample will be approximately 1 kg to process for analysis or subsampling.
3. Sampling is usually easier if the soil is dry.





Figure 12. Soil sampling tools.

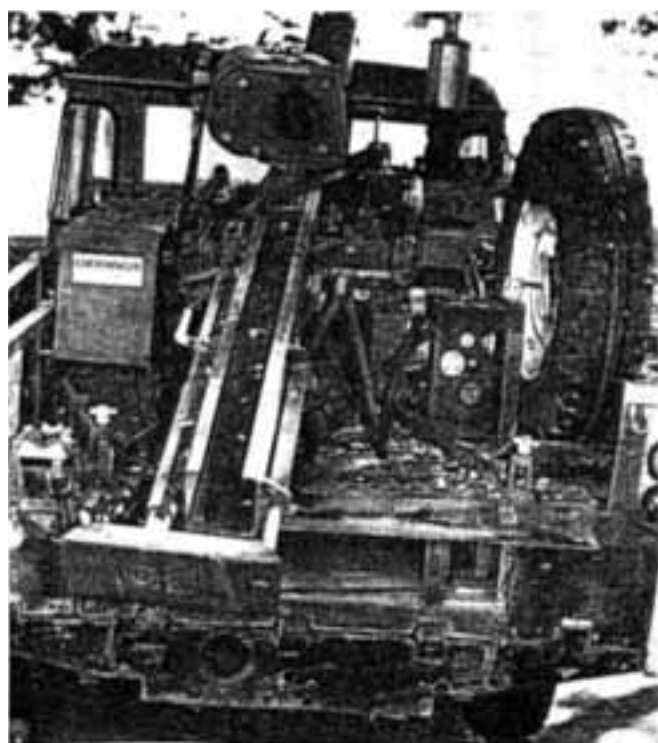

Figure 13. Vehicle mounted coring machine.

Sampling Soil of Established Experimental Plots

Procedure

Each sample area is marked by a stake at each corner. The operator proceeds across the plot in a zigzag path taking a sample to plow-layer depth every two or three steps. Avoid sampling the border of the plot and take samples in a zigzag manner avoiding rows where fertilizers were placed in bands.

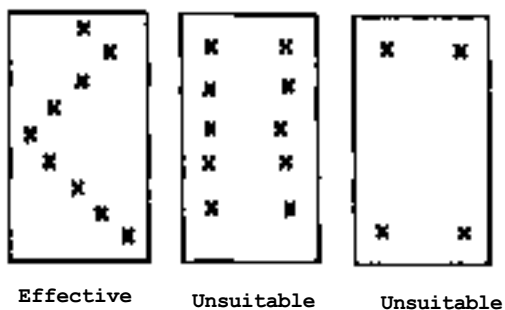

Figure 14. Soil sampling methods.

Sample labeling:

1. Date of sampling.
2. Soil type, field number, and the area of the field.
3. Depth of the soil profile.
4. Cropping history.
5. Address of the sender.

Packing and marking soil samples

Prevent contamination of the sample. Put one label in the bag and the other on the outside of the bag. Record the date of sampling and the date the sample was sent to the laboratory.

Pack the samples in clean waterproof containers, such as plastic bags, cardboard cartons, or strong paper bags. Do not write with ink on the sample bags or boxes. Use only pencil or wax pencil.

Handling of soil samples in the laboratory

Drying. The soil samples are usually air-dried at a temperature of about 25° C to 35° C with relative humidity of 20% to 60%.

Sieving. In normal conditions it is passed through a 6 mm sieve. Soil in the right moisture conditions is passed through a 2 mm sieve by rubbing it over the sieve surface with a clean rubber stopper. All of the soil sample should pass through the sieve without breaking small stones and organic materials.

Grinding. Soil aggregates are broken by grinding lightly with a roller, rubber pestle in an agate mortar, or motorized grinder. Crushing of sand or gravel particles is avoided.

Mixing. The sample is mixed by rolling or turning while holding the opposite corner of the cloth or paper and pulling diagonally across the sample. Repeat by alternating corners for about five times. After mixing, the sample is partitioned into quarters until approximately 500 g remains. This amount will be required for testing and storing. The samples are to be stored in an orderly and well documented clean, dry, and safe place.

C. Layout

Laying Out an Experiment

- 1) **Number of treatments and replications.** The number of treatments depends on the objectives of the experiment, but should not become unwieldy. The number of replications (the number of times the treatments will be repeated), depends on the precision required for the experiment. Availability of land, costs, and precision required are important factors that determine the size of the experiment.
- 2) **Design of the experiment.** Once the treatments are identified, the next step is to select the most appropriate design (randomized-block, a split-plot, or a strip-plot). Once these basic factors are determined, make a plan (blueprint) of the experiment, keeping in mind the slope, past history, and all known variations in the experimental area. Arrange the replications to minimize the variations within replications.

A field plan must show all the details of the experiment as follows:

1. Description and number of treatments with symbols assigned to each treatment.
2. Experimental design with number of replications.
3. Number of plots in the experiment.
4. Plot size (length x breadth)
5. Border areas for the experiment.
6. How the plots and blocks have been arranged.
7. Randomization of treatments and replications.
8. Rates, types, and times of fertilizer application.
9. Seed requirements (plant density).
10. Insecticides, herbicides, weed control methods, amount and kind of fertilizer materials, or special operations.

Layout in the Field

The researcher should thoroughly check for correctness of row or plot numbers and randomization of treatments within each replication before the actual layout is done in the field.

Materials: Measuring tape and stakes.

Procedure

1. Start marking the experimental plot by choosing the southwest corner of the field (Fig. 15) and fix a stake on the first row of the first plot.
2. Form a right-angle triangle (page 4) with the tape and fix two stakes perpendicular to each other, which will form the two sides of the experimental plot.
3. Extend the two sides to the required length of the experiment by your eye-line.
4. Measure and stake to indicate the blocks as per the plan.
5. Leave required alleyways between blocks.
6. Measure and stake the individual plots according to the plan.
7. Check for the correctness of all the measurements so that the plot sizes correspond to the plan by counting the plots and by checking the diagonals.

8. Tie tags on a stake for the first row of each plot, from left to right when facing the field. The tags must indicate plot number, treatment symbol, replication number, and the experimenter's initials. Write with waterproof pencil or ink on weather-resistant tags.

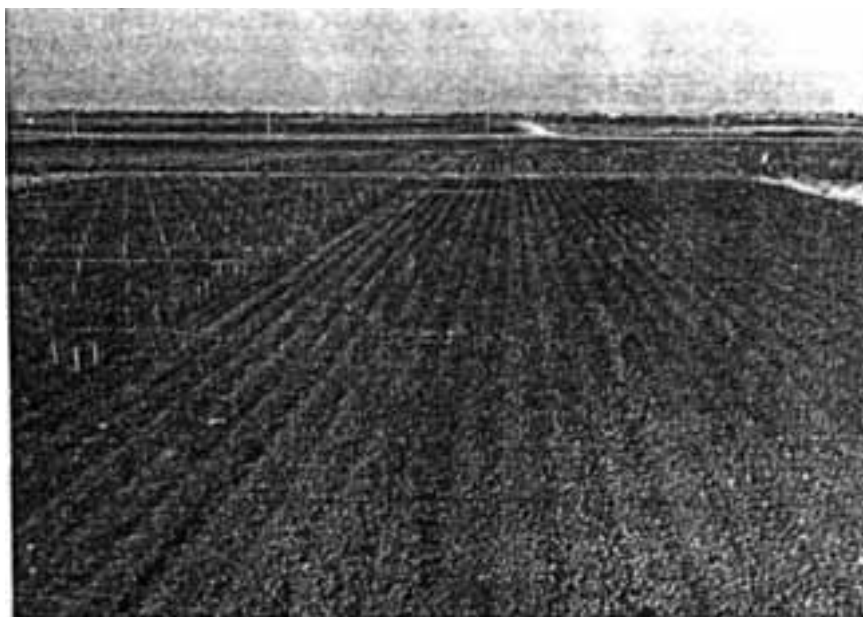

Figure 15. A field ready for layout.

9. If the field is formed into ridges and furrows, you may wish to leave a ridge for an alleyway between plots. If the field is flat and will be irrigated, then each plot may need to be bordered with a 10-15 cm bund. The bunds can be made with a spade, a wheeled tool-carrier, or a ridging plow.

10. Generally, the field should be uniformly leveled with a slope of 0.2% to 0.8%.

11. Apply fertilizers as required by the experiment.

Example of an Experimental Plan

Title of the experiment

Sorghum varietal trial.

Objective of the experiment

Evaluation of six sorghum cultivars for their yield potentials.

Treatments

Number of treatments = 6

Treatment	Symbol	Treatment	Symbol
Variety 1	V1	Variety 4	V4
Variety 2	V2	Variety 5	V5
Variety 3	V3	Variety 6	V6



Design of the experiment

Randomized block design

Other information

1. Plant population to be maintained = 150 000 ha⁻¹
2. Fertilizer application:
 - a. Basal application of 30 kg N ha⁻¹ and 13 kg P ha⁻¹.
 - b. Top dress 30 kg N ha⁻¹ at boot stage.
3. For calculating the amount of seed required, an excess of be added to ensure an opportunity to thin plants to the required plant stand.
4. Number of replications - 4.
5. Total plots - 6 x 4 - 24 (6 treatments x 4 replications).
6. Plot size = 5 m x 3 m
7. Sowing to be done on ridges 5 m long with 75 cm from center to center (hence, four ridges plot⁻¹ of 5 m length).
8. An alleyway of 1 m to be left between ranges (space at end of rows).
9. Therefore, total field size will be 18 m x 24 m (Fig. 16).

Procedure

1. Place a stake at the southwest corner of the field on the first row, which will be the first plot of the experiment.
2. Construct a right angle by taking one side along the first ridge as the perpendicular and the other side across the ridges. Fix two stakes on the ridge and one on the line perpendicular to the rows.
3. Extend the perpendicular line across the ridges by eye-line and fix a stake on the first row of the adjacent experiment and for each additional experiment.
4. From the first stake on the first ridge, measure the plot lengths (5 m) and alleyways (1 m). Fix stakes on the start of the next plot along the first ridge so that four replications with alleyways between them are identified. The total length required will be 24 m in this experiment (Fig. 16).
5. Now, stake the plots across the ridges, put a stake on every fifth ridge, which indicates the first ridge of each plot. This exercise should be done visually (by eye-line) so that the stakes are in straight lines. Each four ridges equals the plot and should be 3 m apart ($.75 \times 4 = 3$ m).
6. Stake each replication in this way. After completion, check the diagonals in the experiment and across the experiments to verify the accuracy of staking.
7. Tag the stakes with required information, i.e., plot number, treatment symbol, replication number, etc.
8. Apply fertilizer by opening a furrow on the ridges and covering it lightly with soil.
9. Sow the seeds as per plan.

Precautions

1. Previous cropping history of the plot should be known, especially in case of fertilizer and intercropping trials.
2. If possible, ascertain soil fertility variations, either by soil analysis or uniformity trial to layout uniform areas for replications or blocks.
3. Row directions (ridges) should be along the slope so that maximum infiltration is permitted and excess surface water drains from the field through the furrows.

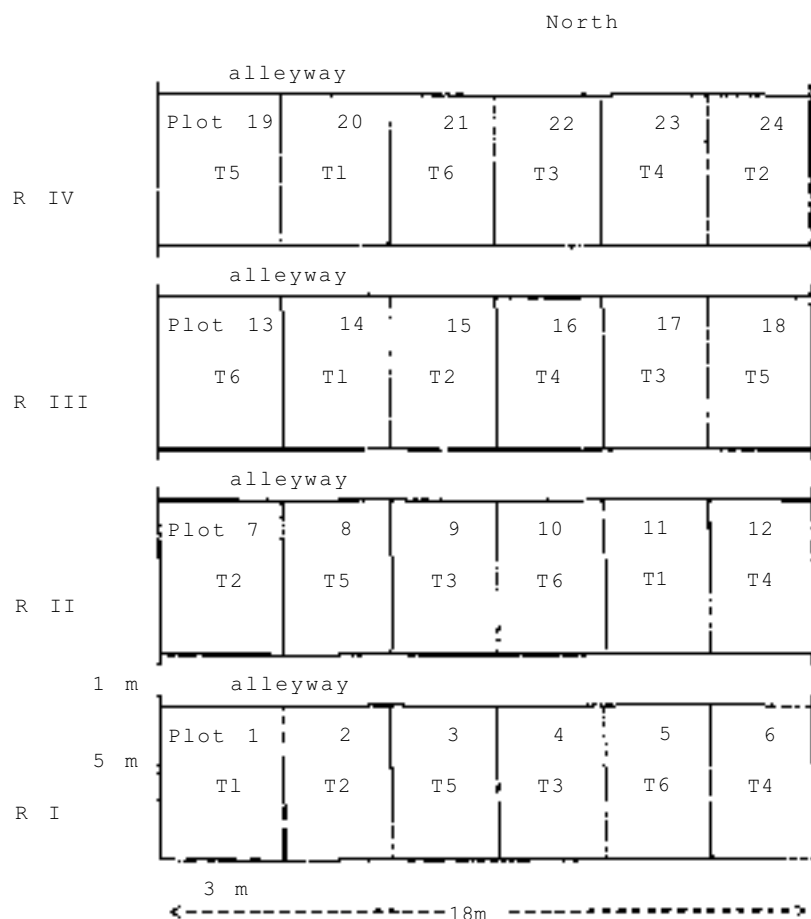

Treatments

Variety 1 - T1	Replications	- 4
Variety 2 - T2	No. of plots	- 24
Variety 3 - T3	Plot size	- 5 m x 3 m
Variety 4 - T4	No. of ridges	- 4 plot ⁻¹
Variety 5 - T5	Row and slope	- south to north
Variety 6 - T6	Alleyway	- 1 m

Figure 16. Layout plan of a varietal trial.

IV	T-1	T-4	T-6	T-2	T-3	T-5
III	T-3	T-5	T-2	T-4	T-1	T-6
II	T-6	T-3	T-4	T-1	T-5	T-2
I	T-1 oooo	T-3 oxxx oxxx	T-5 oxo oxo	T-4 oxxx oxxx	T-2 xxxx xxxx	T-6 oxox oxox

(Treatments are randomized.)

Treatments:

Plot size = 5 m x 3 m

T-1 - sole sorghum (S) - 2 rows bed⁻¹
T-2 - sole cowpea (CP) - 4 rows bed⁻¹
T-3 - 1 S + 3 CP 4 rows bed⁻¹
T-4 - 2 S + 2 CP 4 rows bed⁻¹
T-5 - 2 S + 1 CP 3 rows bed⁻¹
T-6 - 2 S + 2 CP 4 rows bed⁻¹

Symbols: Sorghum = o
Cowpea = x

Plot - two 150 cm broadbeds-and-furrows

Figure 17. Intercropping experiment layout.



D. Fertilizers

Definition and Characteristics

Plant nutrients usually required in large amounts for successful crop production are nitrogen, phosphorus, and potassium. These elements may need to be supplied regularly to maintain balanced soil fertility and high crop production.

Commercially available fertilizers are divided into two groups:

- a) single carrier or straight fertilizers (urea or potassium chloride) .
- b) complex fertilizers with two or more nutrients (monoammonium phosphate or diammonium phosphate).

Analysis or Grade of Fertilizers

The amount of a nutrient element in a fertilizer is expressed as a percentage. Ammonium sulphate has 20% N. This means that every 100 kg of ammonium sulphate contains 20 kg of nitrogen. The three major nutrients are expressed as a percentage of each element in the order N-P-K. A complex fertilizer labeled 14-14-14 contains 14% nitrogen, 14% phosphorus, and 14% potassium. The remaining 58% is carrier materials that may not contain other plant nutrients (Table 1) .

Table 1. Nutrient content of selected fertilizers¹.

	N	P	X	Ca	S
Single carriers					
Ammonium sulphate	20				24
Urea	46				
Ammonium chloride	25				
Anhydrous ammonia	82				
Calcium nitrate	16			21	
Single superphosphate		7- 9		18-21	12
Triple superphosphate		19-23		12-14	1
Potassium sulphate			44		18
Potassium chloride			50-52		
Double carriers					
Diammonium phosphate	18	20			
Monoammonium phosphate	11	17			
Triple carriers					
N-P-K	19-	8-16			
(comes in various	17-	7-14			
brand names)	10-11-22				

¹. The percentages of phosphorus and potassium are expressed as P and K.

- a. To convert P_2O_5 to P; multiply P_2O_5 content by 0.43
- b. To convert K_2O to K; multiply K_2O content by 0.83

Mixing and Storage of Fertilizers

When a fertilizer treatment requires more than one element, it is possible to apply single carriers or complex fertilizers. However, this may not always be possible as not all fertilizer carriers are compatible. Fertilizers are chemicals and will react with one another. Some are highly reactive and after mixing may become hard and difficult to handle. To decide which fertilizer carriers can be mixed, you must consider the compatibility of fertilizer materials (Fig. 18).

Table of Compatability

■	◊	◊	◊	◊	◊	◊	◊	◊	◊	◊	◊	◊	◊	◊	◊	◊	1 Calcium nitrate
◊	◊	◊	◊	◊	◊	◊	◊	◊	◊	◊	◊	◊	◊	◊	◊	◊	2 Chilean nitrate
◊	◊	◊	◊	◊	◊	◊	◊	◊	◊	◊	◊	◊	◊	◊	◊	◊	3 Cal Am nitrate
◊	◊	◊	◊	◊	◊	◊	◊	◊	◊	◊	◊	◊	◊	◊	◊	◊	4 Am sulph nitrate
◊	◊	◊	◊	◊	◊	◊	◊	◊	◊	◊	◊	◊	◊	◊	◊	◊	5 Nitropotash
◊	◊	◊	◊	◊	◊	◊	◊	◊	◊	◊	◊	◊	◊	◊	◊	◊	6 Am sulphate
◊	◊	◊	◊	◊	◊	◊	◊	◊	◊	◊	◊	◊	◊	◊	◊	◊	7 Nitrogen magnesia
◊	◊	◊	◊	◊	◊	◊	◊	◊	◊	◊	◊	◊	◊	◊	◊	◊	8 Urea
◊	◊	◊	◊	◊	◊	◊	◊	◊	◊	◊	◊	◊	◊	◊	◊	◊	9 Calcium cyanamide
◊	◊	◊	◊	◊	◊	◊	◊	◊	◊	◊	◊	◊	◊	◊	◊	◊	10 DAP
◊	◊	◊	◊	◊	◊	◊	◊	◊	◊	◊	◊	◊	◊	◊	◊	◊	11 Superphosphate
◊	◊	◊	◊	◊	◊	◊	◊	◊	◊	◊	◊	◊	◊	◊	◊	◊	12 TSP
◊	◊	◊	◊	◊	◊	◊	◊	◊	◊	◊	◊	◊	◊	◊	◊	◊	13 Basic slag
◊	◊	◊	◊	◊	◊	◊	◊	◊	◊	◊	◊	◊	◊	◊	◊	◊	14 Rock Phosphate
◊	◊	◊	◊	◊	◊	◊	◊	◊	◊	◊	◊	◊	◊	◊	◊	◊	15 Muriate of Potash
◊	◊	◊	◊	◊	◊	◊	◊	◊	◊	◊	◊	◊	◊	◊	◊	◊	16 Pt. sulphate
◊	◊	◊	◊	◊	◊	◊	◊	◊	◊	◊	◊	◊	◊	◊	◊	◊	17 K-Mg Sulphate
■	◊	◊	◊	◊	◊	◊	◊	◊	◊	◊	◊	◊	◊	◊	◊	◊	
◊	◊	◊	◊	◊	◊	◊	◊	◊	◊	◊	◊	◊	◊	◊	◊	◊	

■ Can be mixed
 ◊ Cannot be mixed
 ◊ Can be mixed but not stored

Figure 18. Guide for mixing and storing fertilizers.
 (Source: Handbook of Manures and Fertilizers. 1971.ICAR, New Delhi.)

Procedure

1. Select available carriers and consult figure 18 for compatibility.
2. Do not mix fertilizers of greatly different particle sizes as they tend to separate during handling.
3. Compute the required amount of the individual fertilizers.
4. Weigh the fertilizers to be mixed (nearest 0.1 kg). If the mixture is more than 75 kg then prepare it in two or three batches to achieve uniform blending.
5. Spread the fertilizers in layers, one above the other on a smooth and clean surface.
7. With a shovel, shift fertilizer from the edge of the pile to the center of a new pile. Continue shoveling to a new pile until it is impossible to distinguish streaks of individual fertilizers in the mixture.
8. Alternately, use a cement mixer to mix the fertilizer carriers.



Storing fertilizer materials

Fertilizer usage may be essential in modern crop production technologies. Uniform crop growth depends upon the availability of the nutrients from the soil and uniformly distributed fertilizers to areas of the soil that are deficient in one or more nutrients. Uniformity of fertilizer distribution is affected by the way the fertilizers are stored.

Procedure

1. Select a storage area that is well ventilated and dry.
2. Place wooden pallets on the floor and stack fertilizer bags on the pallet.
3. Do not place more than eight bags in a stack. Otherwise, the pressure on the bottom bag will cake the fertilizer.
4. Stack only unbroken bags and arrange the stacks closely to minimize air space between stacks.

Precautions

1. Do not store fertilizer with insecticides or herbicides.
2. Do not store with fuels, oil, flammable liquids, acids, sulphur, or explosives.
3. Do not smoke in the storage area.
4. Store the fertilizer in moisture-proof containers or bags to prevent it from absorbing moisture from the air. Close tightly and keep separately any opened bag.

Fertilizer Calibration

Objectives

1. To calculate the rate of nutrients to be applied per unit area.
2. To identify the fertilizers that will supply the nutrients, either singly or in combinations (Table 1).
3. To calculate the amount of fertilizer that will supply the required amount of nutrients ha^{-1} , m^{-2} , plot^{-1} , or for a row. Application rates of each major nutrient is reported as kg ha^{-1} .

Procedure for calculation

Calculate the quantity of a straight fertilizer to supply $120 \text{ kg of N ha}^{-1}$ for a plot with 10 rows. Each row has a length of 10 m and width of 0.5 m. Therefore, the total area is 50 m^2 . The fertilizer to be used is ammonium sulphate.

1. Ammonium sulphate contains 20% N, or 20 kg N in each 100 kg.
2. Therefore, 120 kg N will be available from:
$$\frac{100 \text{ kg ammonium sulphate} \times 120 \text{ kg N}}{20 \text{ kg N}} = 600 \text{ kg of ammonium sulphate.}$$
3. To supply 120 kg N ha^{-1} requires 600 kg of ammonium sulphate.

4. The required ammonium sulphate is to provide 120 kg N ha⁻¹ will be:

$$\frac{600 \text{ kg ha}^{-1} \text{ ammonium sulphate} \times 1000 \text{ g kg}^{-1}}{10,000 \text{ m}^2 \text{ ha}^{-1}} = 60 \text{ g m}^{-2} \text{ of } (\text{NH}_4)_2\text{SO}_4$$

5. The area of each row is 10 m x 0.5 m or 5 m².

6. Therefore, the ammonium sulphate required row⁻¹ is:

$$60 \text{ g m}^{-2} \times 5 \text{ m}^2 = 300 \text{ g row}^{-1}$$

7. The plot area in this example is 10 m x 5 m or 50 m².

8. The amount of ammonium sulphate for a plot of 50 m² will be:

$$60 \text{ g m}^{-2} \times 50 \text{ m}^2 = 3000 \text{ g or } 3 \text{ kg plot}^{-1}.$$

Similarly, the other two plant nutrients can be obtained by using straight fertilizers such as single superphosphate (7% P) or triple superphosphate (20% P), and muriate of potash (50% K).

Calculation procedure for using double carriers

When two nutrients are to be applied simultaneously, we can use double carriers. For instance, if nitrogen and phosphorus are to be applied, we can use diammonium phosphate (DAP), that contains 18 kg N and 20 kg P per 100 kg and urea that contains 46% N.

In an experiment, the row length is 10 m, row width is 0.5 m, and the plot area is 50 m². The desired application is 100-17-0 ha⁻¹ by using DAP and urea.

1. First, calculate the quantity of DAP to provide 17 kg of P. DAP contains 20% P and 18% N. Therefore, 17 kg P would be supplied in:

$$\frac{17 \text{ kg P} \times 100 \text{ kg DAP}}{20 \text{ kg P}} = 85 \text{ kg DAP.}$$

2. Now, find the N available in 85 kg of DAP if 100 kg of DAP has 18% N

$$\frac{18 \text{ kg N} \times 85 \text{ kg DAP}}{100 \text{ kg DAP}} = 15.3 \text{ kg of N.}$$

3. The experiment requires 100 kg N ha⁻¹ and 15.3 kg N will be applied by 85 kg DAP ha⁻¹. The required N from urea is 100 kg N - 15.3 kg N or 84.7 kg N.

4. Urea contains 46% N. Therefore, 84.7 kg N will be available from

$$\frac{100 \text{ kg urea} \times 84.76 \text{ kg N}}{46 \text{ kg N}} \text{ or } 184 \text{ kg of urea.}$$

5. Therefore, 85 kg of DAP and 184 kg of urea will be required to provide 100-17-0.

6. The required DAP is 8.5 g m⁻² and required urea is 18.4 g m⁻².

7. To obtain the amount of these fertilizers for one row, multiply the amount m⁻² by the m² row⁻¹. If the row is 10 m by 0.5 m it would contain 5 m² and the DAP required will be 5 m² x 8.5 g m⁻² or 42.5 g row⁻¹ and the urea required will be 5 m² x 18.4 g m⁻² or 92 g row⁻¹. To obtain the amount plot⁻¹ multiply the amounts row⁻² by the number of rows plot⁻¹.

Fertilizer Application

Most soils will need some fertilizers applied for good crop establishment, good vegetative growth, and increased grain production. The elements that are frequently needed for good crop growth are nitrogen and phosphorus. The fertilizers supplying these nutrients may be applied as a basal application before or at sowing. Sometimes a portion of the required amount is applied as a top dressing. Fertilizer needs to be applied carefully so that the material does not injure germinating seeds. At the same time, the required amount of various nutrients must be available near the seedlings for them to produce the desired yield.

Application at sowing

Procedure

1. Open the furrows with tractor-mounted or hand-drawn furrow openers a little deeper than the sowing depth. The fertilizers should be placed slightly below the seeds and to the side to avoid fertilizer burn from direct contact with the emerging primary root (Fig. 21).
2. Distribute the calculated amount of fertilizer uniformly in a band, one replication at a time.
3. Cover the fertilizer lightly with soil to prevent direct contact of fertilizer with the seed.
4. Complete each fertilizer application, replication by replication. Do not hand apply fertilizer across replications.
5. Sow the seed, close the furrows, and immediately compact the soil around the seed.
6. Animal drawn fertilizer drills (Fig. 19) or tractor drawn applicators (Fig. 20) could be used for placing fertilizers before sowing.

Top dressing

Most of the crops will need a top dressing of fertilizer, especially nitrogenous fertilizer, to meet the demand of the crop at the critical stages of plant growth. Top dressing is usually done for sorghum and millet just prior to the boot stage.

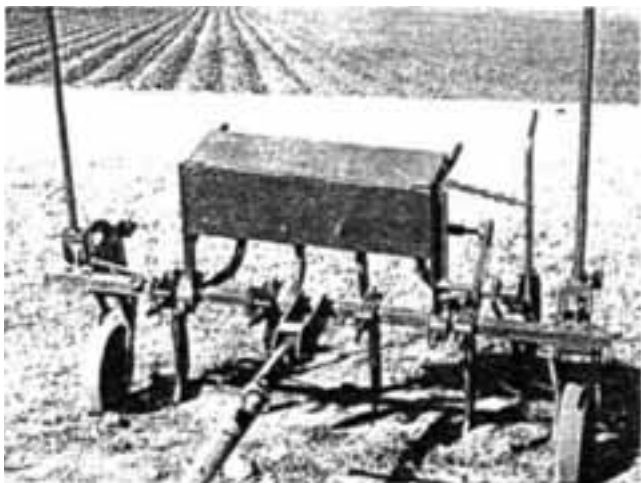

Figure 19. Animal drawn fertilizer applicator.



Figure 20. Tractor drawn fertilizer applicator.

Procedure for side dressing

1. Open a furrow with a sickle, hoe, or tine about 5-6 cm deep and about 5-6 cm away from the crop row, one replication at a time. Do not damage the roots while opening the furrows. Hand applications can be made by making holes beside and between the plants to reduce root damage. Drill holes uniformly 5-6 cm away from each plant or in clusters of two to three plants. The holes should be 5-6 cm deep. Care should be taken to distribute the fertilizer uniformly among the holes.
2. Distribute the fertilizer uniformly to all plants.
3. Cover the fertilizer immediately after application.
4. Proceed replication by replication.
5. In intercropping trials where more than two rows of crops have been sown closely, fertilizer may be top dressed by opening furrows near the cereal row in a cereal/legume combination. Fertilizer may be side dressed to the cereal crop in the same way as for a sole crop.



Figure 21. Place fertilizer to the side and slightly below the seed.

E. Seed Calibration and Sowing

Estimation of the Quantity of Seed Required for Sowing

Optimal and uniform plant stands are prerequisites for successfully determining the yield differences due to the influence of genotype, fertilizers, or other factors. A uniform plant stand reduces the experimental error. Seed samples generally contain some non-viable seeds. Poor germinating seeds are due to unfilled, damaged, and dead seeds. The sowing rate can be adjusted if the germination percentage and seed mass of each seed lot are known.

Example

Calculate the quantity of sorghum seed required for an experiment when the seed lot has 95% germination. The mass of 100 seeds of this variety is 2.5 g. The plot area is 1000 m² and for each row is 10 m². The desired plant density is 200 000 plants ha⁻¹.

Calculate the quantity of seed required:

- o ha⁻¹
- o m⁻²
- o plot⁻¹
- o row⁻¹.

Calculations

A seed lot contains some seeds that will not germinate. Therefore, an extra quantity of seed will be required to obtain the desired plant population.

First, calculate the amount of seed required to get 100 germinable seeds when the germination of the seed lot is 95%. The 100 germinable seeds can be obtained from:

$$\frac{2.5 \text{ g (100 seed mass)}}{0.95 \text{ (\% germination)}} = 2.63 \text{ g for 100 germinable seeds.}$$

Therefore, 200 000 germinable seeds (for 200 000 plants ha⁻¹ or 20 plants m⁻²) will weigh:

$$\frac{2.63 \text{ g germinable seed} \times 200\,000 \text{ plants ha}^{-1}}{100 \text{ germinable seeds (plants)} \times 1000 \text{ g kg}^{-1}} = 5.26 \text{ kg ha}^{-1}$$

Therefore, for 1 ha the amount required is 5.26 kg.

- o seed for 1 m² = $\frac{5260 \text{ g ha}^{-1}}{10\,000 \text{ m}^2 \text{ ha}^{-1}} = 0.526 \text{ g m}^{-2}$
- o for 10 m² (row area) = 0.526 g m⁻² x 10 m² row⁻¹ = 5.26 g row⁻¹
- o for 1000 m² (plot area) = 0.526 g m⁻² x 1000 m² = 526 g plot

Establishing the Required Plant Population

It is essential to establish a uniform plant stand in all the plots of an experiment. Therefore, calculate the optimal plant stand for the unit area (row length) for obtaining the desired stand.

Example

A sorghum experiment has a plot size of 3 m x 5 m with a row spacing of 0.75 m. The direction of the rows is along the length of the plot. Assume the desired plant stand is 50 000 plants ha⁻¹. Solve the following five problems:

1. Number of rows plot^{-1} .
2. Number of plants m^{-2} .
3. Number of plants plot^{-1} .
4. Number of plants row^{-1} .
5. Number of plants m^{-1} of row.

Calculation

Since the rows are laid along the length of the plot, the row length is 5 m.

1. Therefore, the number of rows plot^{-1} =

$$\frac{3 \text{ m plot}^{-1}}{0.75 \text{ m row}^{-1}} = 4 \text{ rows plot}^{-1}.$$

2. Plants m^{-2} = $\frac{50,000 \text{ plants ha}^{-1}}{10,000 \text{ m}^2 \text{ ha}^{-1}} = 5 \text{ plants m}^{-2}$.

3. The number of plants plot^{-1} =

$$15 \text{ m}^2 \text{ plot}^{-1} \times 5 \text{ plants m}^{-2} = 75 \text{ plants plot}^{-1}.$$

4. The plants required for row^{-1} =

$$\frac{75 \text{ plants plot}^{-1}}{4 \text{ rows plot}^{-1}} = 18.75 \text{ or } 19 \text{ plants row}^{-1}$$

5. The plants m^{-1} of row =

$$\frac{19 \text{ plants row}^{-1}}{5 \text{ m row}^{-1}} = 3.8 \text{ plants m}^{-1}.$$

Packeting of Seed for Sowing

It is essential to sow comparable amounts of germinable seed for each variety in each row or plot to obtain a uniform plant stand. When different varieties or species of crops are used in the same experiment, the seed mass required will depend on the 100-seed mass, desired plant population, and the germination percentage. Therefore, seeds should be carefully tested for % germination, weighed and packaged for each seed lot.

Procedure

1. The seed packets are prepared by writing on each packet (Fig. 22):
 - a. Row number.
 - b. Name of the variety or treatment.
 - c. Quantity of seed.
 - d. Person handling the experiment.

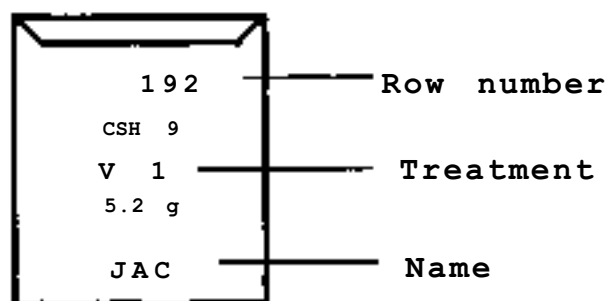

Figure 22. Seed packet preparation.



2. Collect all the seed packets for one variety, irrespective of plot or replication. The row numbers on these collected packets may not be in sequence at this stage. This grouping of packets will facilitate filling all the packets for one variety with the calculated amount of seed at one time.

3. Weigh the seed required row⁻¹ (5.2 g) and put it in a small diameter container. Mark the seed level on the container (Fig. 23). This mark will enable quick seed measurement, especially when filling hundreds of packets with the same amount and variety of seed.

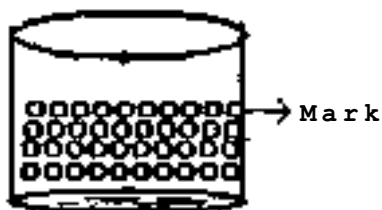

Figure 23. A container with measured seed.

4. Fill the container with seeds up to the mark, then transfer the seeds into the seed packets. When all the seed packets have been filled, rearrange them according to the sowing plan. In this way, the seed packets for one variety rows are prepared for a particular experiment and are then placed in a tray according to the row number. Check the arrangement carefully with the sowing plan to avoid mistakes.

Seed Packeting for Machine Sowing

Sowing experimental material with cone machines (seed drills) has the advantages of uniform dropping of seed, maintenance of uniform depth, and firm and uniform compaction. Therefore, sowing with a machine ensures more uniform germination and the establishment of the desired plant stand.

Seed packet arrangement for a multirow tractor-sowing machine differs from the seed packet arrangement for hand sowing. Usually, the rows are sown across ranges with a multi-row machine, hence the seed packets need to be arranged along the row in the direction of sowing.

Procedure:

When one row, two rows, or four rows are sown in one pass of the machine, the packets must be arranged in the order sown in each plot, by row(s) across the field. When the machine turns to sow in the reverse direction, the row order will be shifted to follow the return row by plot order (Fig. 24).

All the seed packets should first be arranged in a box according to the field map. Then the packets are separately bunched and held together by a rubber band or stapled by row and then grouped for a one-row, two-row, or four-row machine.

Keep the seed packets for each row in order in one box for one direction. Keep packets for the reverse direction at the other end of the field for the return sowing.

When packets are laid out in a box by field plans, pick up the seed packets that should be bunched together for cones A, B, C, or D, keeping in mind the position of the machine (one-row, two-row, four-row) and when traveling in the reverse direction. A complete packeting arrangement for this example is given (Fig. 24). Sowing starts with row numbers 101, 102, 103, and 104.

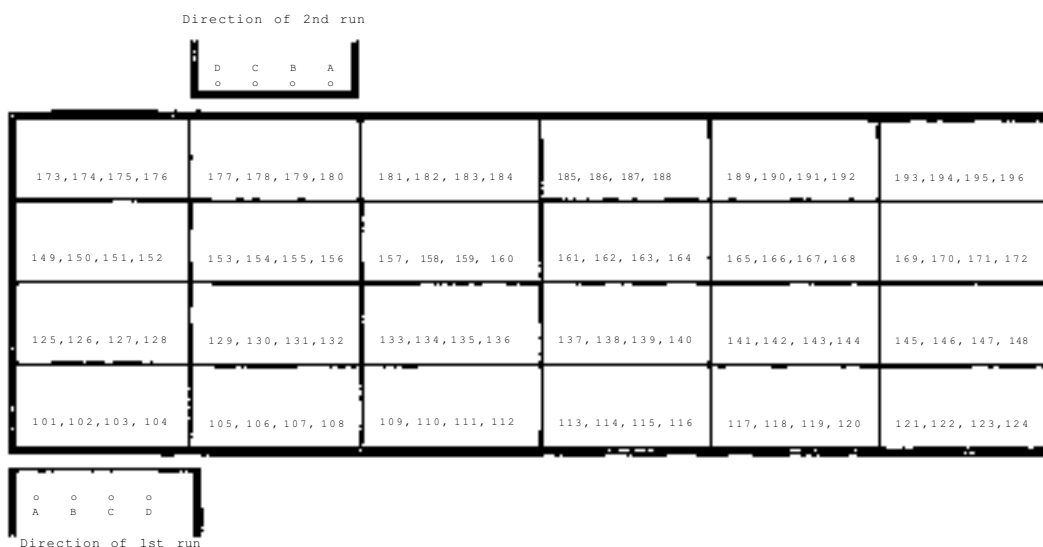

Figure 24. Seed packets by row numbers to be bunched together in sequence for each cone of the machine.

Hand-sowing Procedure

The numbered seed packets are to be laid at the beginning of each row (Fig. 25) according to its row number. After all the packets have been placed by replication, the experimenter must check the stakes and row numbers for correct arrangement.

1. A furrow with 2-5 cm depth, depending on the size of the seed (millet 2.5 cm, sorghum 5 cm), is made on the ridge or bed surface (Fig. 26).
2. All the seeds from the packet are distributed uniformly within the row.
3. The seed is then covered with the soil from both sides (Fig. 27) and firmly compacted with feet or a weighted wheel.
4. It may be difficult with hand tools to obtain straight rows with uniform depth. The rows can be made with a hand-drawn or animal-drawn marker or furrow opener made with pointed angle irons mounted on a wooden plank (Fig. 28). The handle can be made from pipes or iron rods. When the marker is pulled forward, the angle irons will open a shallow furrow on each ridge. The depth of the furrow will depend on the angle of the pointed angle-iron markers. A tractor-mounted row opener can also be used. By careful handling, straight furrows with uniform depth and distance between rows can be opened with a hand-drawn marker.

Sowing the seed at a uniform depth in the compacted soil is essential to achieve the uniform and rapid emergence of seedlings.



Figure 25. Seedbed ready for sowing.



Figure 26. Opened row on the ridge.



Figure 27. Hand covering the rows.

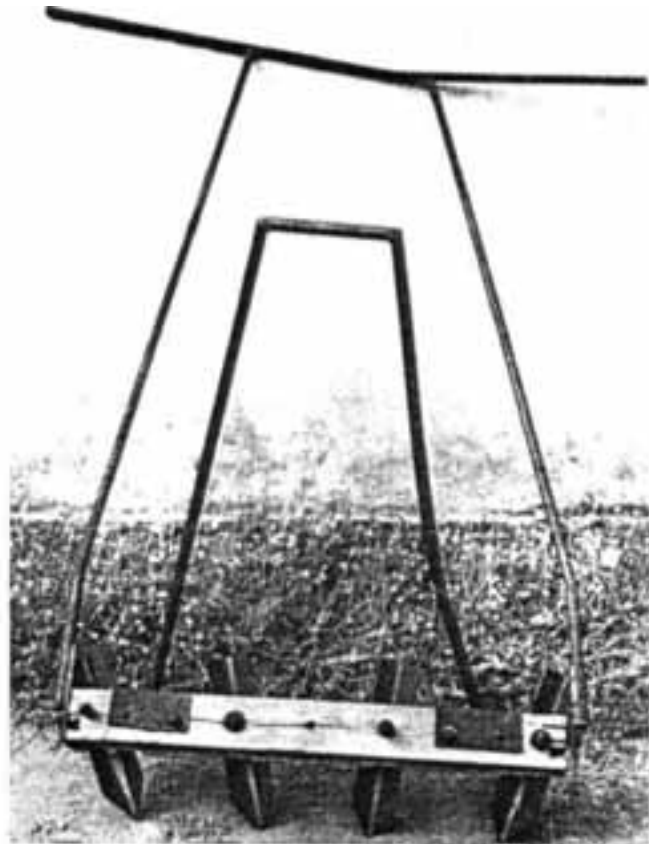

Figure 28. Four-row furrow openers.

Sowing by Machine

Sowing by an animal-drawn planter (fig. 29) or tractor planter (Fig. 30) is quick, accurate, and uniform, especially when the soil moisture level may be critical. Machine sowing will result in more uniform germination as the furrows are opened and closed immediately, the seed placement can be more uniform, and the soil can be uniformly packed around the seed.

Procedure

1. Write row numbers on the packets as per the plan and fill them with the required quantity of seed.
2. Carefully check the row numbers and bunch the seed packets as per the cone number of the machine.
3. Bunch all the seed packets further as per the direction of travel of the machine.
4. Keep one person at each end of the field to hand packets to the person who will drop the seeds in the cones.
5. If four rows are to be sown simultaneously, one person is required for each group of packets to drop the seeds into the divider of each cone.
6. Before the start of each run, the arranged packets are obtained for each cone to be marked in order of sowing by cone and direction.
7. After each person checks the packets, the person will open the first packet and drop it in the cone.
8. Position the machine so that the wheels are just before the beginning of the rows for sowing.
9. Start the machine and as soon as the wheels are in line with the starting marker of the first plots, hand-trip mechanism to release the seeds into the funnel that regulates the dropping of the seed into the furrows by the speed of the rotating disc.
10. As soon as the seed is released from the funnel (no seed at this stage is in the funnel) the next packet should be opened and the seeds dropped into the cones.
11. The operator will release the seeds from the cones as soon as the wheels are at the beginning of the second plot and the third packet should be emptied into the cones.
12. When sowing is completed for the first run (in one direction), the machine will make a U-turn. The person on the other end of the field will distribute the seeds for the second run in the reverse direction and the first packets for the first plots of the return run should be opened and dropped into the cones.

Precaution

1. Care should be taken to keep the arranged seed packets in perfect order.
2. Persons sitting behind each cone should understand the packet arrangement.
3. The machine operator must check that no tubes are clogged and that all seeds are being dropped freely into the soil (Fig. 31).
4. Before sowing, the machine must be adjusted to fit the exact row length and sowing depth.



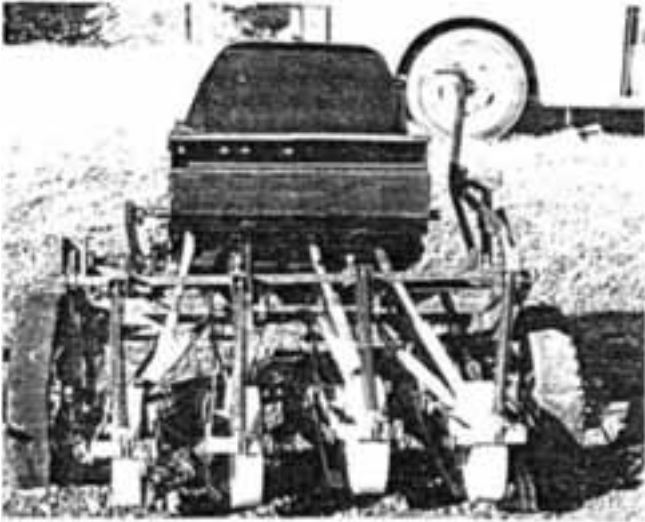

Figure 29. Animal drawn planter.



Figure 30. Tractor operated planter.



Figure 31. Checking seed drop.

Sowing in Different Soil Types

Management of sowing operations in Vertisols (black soils) differs from Alfisols (red soils) .

In Vertisols, immediately after a rain, the soil surface becomes sticky due to the high clay content and sowing cannot be done unless the soil surface becomes dry. Thus sowing will be delayed if it rains continuously or at short intervals. To avoid this and to complete sowing on time, seeds can be sown in dry soil just before the rains are expected.

Sowing in dry soil should be done at a uniform depth as determined by seed size, moisture holding capacity of the soil, and anticipated frequency of initial rains. The soil should be uniformly compacted around the seed to ensure uniform and rapid seedling emergence. Once the sowing is completed in a dry seedbed, the seeds will not start germinating until moisture reaches the depth of sowing. When dry sown, seeds are placed deeper so that a light shower will not be sufficient to wet the seeds and start their germination. The species with large seeds can be sown deeper (maize, pigeonpea, and sorghum). When the seeds are sown too deep, the seedlings produce a longer epicotyl than when sown shallow. Such seedlings take longer to emerge and become somewhat weaker by the time of emergence.

The depth of dry sown seed should be such that germination will start only after the rainfall has provided adequate soil moisture for seedling growth until the next predicted shower (10-15 days). Therefore, one must be ready for resowing if the second rain is greatly delayed. Any gap filling must be completed within 3-5 days after general emergence or the entire experiment may require resowing.

Sowing in Alfisols is done under moist conditions as there is little problem entering the field a day or two after the rain is received. However, sowing must be finished quickly before the moisture in the top layer is lost. The moisture-holding capacity of Alfisols is much lower than for Vertisols. Therefore, after opening the shallow furrow to a depth suited to the seed size, the seed must be sown immediately and firmly compacted to prevent loss of surface moisture.

Filling Gaps After Germination

Seedling emergence may not be uniform in an experiment due to poor seed quality, inadequate soil moisture, soil-borne diseases, insect damage, faulty compaction during sowing, or non-uniform sowing depth. If a plant stand is not uniform, gap filling or resowing the experiment may be necessary. Gaps must be filled to ensure that intra-row as well as inter-row competition is uniform (Fig. 32) .

Procedure

1. After evaluation emergence small areas may be gap filled so that the vegetative growth of the plants will be similar. Gap filling of sorghum and millet must be completed within 2-3 days after the emergence of the seedlings from the original sowing.
2. As a rule of thumb, any gap larger than 30 cm should be resown.
3. Open furrows (if the gap is large), drop the seeds, cover, and compact the soil. For small gaps, dibble the seeds at specified distances by dropping 2-3 seeds in each hole.
4. It is essential to fill the gaps in all border rows so that crop competition is provided to the central rows for data collection.
5. If more than one variety is used, care should be taken to gap fill with the seed of the correct variety.

6. Always keep seed in stock so that gap filling can be done quickly. Under semi-arid tropical conditions, gap filling or resowing may be frequently required.



Figure 32. Gaps between plants.

F. Crust Breaking on Alfisols

Alfisols (and associated Inceptisols) are red soils. They are usually sandy loam or sandy-clay-loam soils having mostly a single-grain structure with weak granular or weak subangular-blocky structures. The clays in these soils are predominantly of the kaolinite or non-swelling types (ICRISAT 1987). One of the major problems in these soils is the formation of a hard crust or the sealing of the surface after an intense rainfall (Fig. 33). Even sprinkler irrigation may cause crusting. This type of crust or compaction is visible. It is a few millimeters thick, and is created by destruction of aggregates due to immersion or the direct raindrop impact. This crust, when dry, will form a barrier against seedling emergence, good aeration, and entrance of water. Pearl millet is especially vulnerable to this crust formation as the emerging epicotyl has difficulty penetrating the crust. As a result, crop establishment may seriously suffer on the red soils. Careful watch must be maintained for any crust formation, especially if a heavy rain is immediately received after sowing. If a crust is formed, it should be broken to facilitate the emergence of the seedlings.

Procedure

1. A crust may be broken manually with a hoe or sickle if the experimental area is small. Breaking the soil crust may be restricted to only the sowing zone and care should be taken not to dig too deeply so that emerging seedlings are not injured.
2. A crust may be broken by a bullock-drawn wheeled tool carrier or crust breaker.



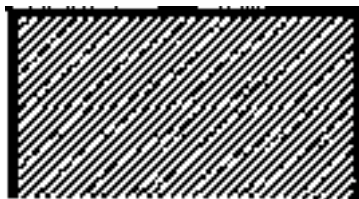

Non-aggregated soil

- impedes only infiltration, active when wet
- effective layer: < 0.1 mm



Aggregated soil

- impedes both infiltration (wet) and seedling emergence (dry)

Figure 33. Different types of seals or crusts.

ICRISAT crust breakers consist of two spiked rollers, angled one behind the other in a frame. The tool is easy to use as a manually operated single-row implement (Fig. 34). The implement has two 150 mm rollers, their width is 15 cm, with 16 rows of spikes 25 mm in length. The crust breaker covers a strip of 180 mm over the seed row. This equipment can be used successfully in breaking the crust one day prior to emergence if the crust strength is below 2-2.5 kg cm⁻² as measured by a penetrometer. Experiments conducted at ICRISAT showed significant improvement in emergence of pearl millet and sorghum compared to unbroken, crusted conditions.

The crust breaker has been modified and enlarged so that it can be pulled by a pair of bullocks as an independent implement (Figs. 35 and 36). Weeds may be partially controlled with the same operation.

Precaution

The most important aspect of the crust-breaking operation is timing. Crust breaking should be done ahead of the expected crop emergence, as a delay may cause injury to the emerging seedlings. A pocket penetrometer may be used to judge the strength of a crust.



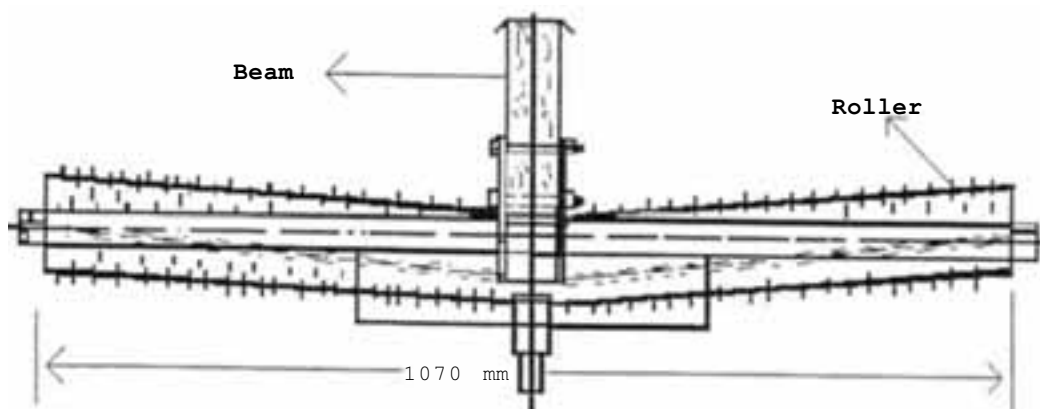

Figure 34. Details of inclined-roller crust breaker, top view.



Figure 35. Independent inclined-roller crust breaker.



Figure 36. Inclined-roller crust breaker with a plank.



G. Harvesting of Experimental Crops

Timely harvest is important to reduce mold damage, bird damage, insect damage, and losses due to shattering and wet weather. Crops may be harvested when they are physiologically mature. At this stage, the moisture content of the grain is about 30%. The following chart indicates physiological maturity and when the grain can be harvested without a yield reduction.

Crop	Symptoms
o Sorghum	The grain forms a black layer at the hilum.
o Millet	Similar to sorghum.
o Groundnut	Kernels develop a distinct seed-coat color and the inside of the shell develops dark marks.
o Pigeonpea	Pods dry, seed develops a typical color of the variety and becomes hard, but before the seed shatters.

Method of harvesting cereals

1. Varieties should be harvested according to maturity groups and at physiological maturity.
2. Cloth bags should be tagged, indicating plot, treatment, and replication numbers (Fig. 37) on the outside and a second tag with identical information should be placed inside the bag.
3. Harvest all replications for a variety that matures on a given day.

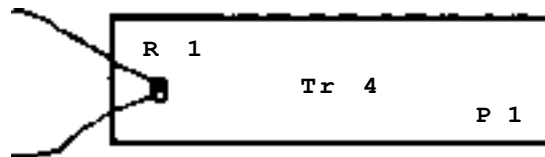

Figure 37. Plot, treatment, and replication number.

4. If the plot has four rows, the two outer rows are border rows and not harvested as part of the plot yield. If the row is 5m long, a 3-m stick can be used to indicate the length of row to be harvested leaving 1 m at each end as borders.
5. Use a hand clipper, sickle, or knife for harvesting (Fig. 38). Cut the panicle at a uniform distance below the panicle.
6. Harvest 5 or 10 panicles at a time and drop them directly inside the bag, so that no grain is lost or contaminated with soil. In this way, it is easy to count the panicles by 5's or 10's as cut. Record the counts directly in your record book to avoid errors by recopying data.
7. As soon as one plot is harvested, tie the bag and immediately weigh it. Do not permit the bag to remain in the sun before weighing if the fresh mass is required.
8. After harvesting all the plots for the day, the panicles are to be dried in the sun or in a dryer to constant moisture. Threshing should start only when the panicles are uniformly dried to constant mass.



Figure 38. Harvesting equipment.

References

1. A brief description of soils of ICRISAT. Semiformal Report of RMP, 1974.
2. ICRISAT, 1987. Alfisols in the semi-arid tropics. Proceedings of the consultant's workshop on the State of the art and Management Alternatives for Optimizing the Productivity of SAT Alfisols and Related Soils, 1-3 Dec 1983, ICRISAT Center, Patancheru, A.P. 502 224, India.
3. ICRISAT Annual Report 1986.

H. Evaluation

Select the most appropriate answer and check the correct answer at the end of the booklet.

Formation of a Rectangle

1. It is not necessary to have a field with right-angle corners for an experiment. True/False.
2. The Pythagorean theorem states that
 - a) the sum of the sides of a right-angle triangle equals the hypotenuse.
 - b) the sum of the squares of the two sides of a right-angle triangle equals the square of the hypotenuse.
 - c) the sum of squares of the two sides is equal to the hypotenuse.
3. A right-angle triangle can be formed with
 - a) sides 3, 5, and 6.
 - b) sides 12, 16, and 20.
 - c) sides 30, 24, and 18.
 - d) sides of 2, 3, and 4.

Estimation of the Area of a Field

- 1) Estimation of the area of a field can be done
 - a) with a notebook and a pen.
 - b) by pacing.
 - c) with a calculator.
 - d) None of the above.
- 2) An estimation of the area of a field helps the scientist to
 - a) achieve quick results in an experiment.
 - b) conduct a good experiment.
 - c) select a suitable area in the cultivator's field or on a research farm for an experiment.
 - d) arrange irrigation effectively for a field.
- 3) The average length of pace is calculated by
 - a) multiplying the number of paces with the distance paced.
 - b) subtracting the number of paces from the distance paced.
 - c) dividing the length paced by the number of paces.
 - d) dividing the distance paced with half the number of paces.
- 4) The length of the side of a field is calculated by
 - a) dividing the number of paces of a side with the average pace length.
 - b) multiplying half the pace length with the number of paces.
 - c) multiplying the number of paces of a side by the average length of pace.
 - d) none of the above.
- 5) The area of the field is calculated by
 - a) multiplying half the length with the breadth.
 - b) multiplying the length with the breadth.
 - c) adding all four sides.
 - d) multiplying the two opposite sides.
- 6) If:
 - o The length of a pace is 0.75 m.
 - o The length of the field is 400 paces.
 - o The width of the field is 300 paces.
 - o Then the area of the field will be
 - a) 3.5 ha.
 - b) 4.5 ha.
 - c) 8.0 ha.
 - d) 6.75 ha.

Calculating a Slope

1. A flat land with 0% slope is desirable for irrigated experiments. True/False
2. Some slope is required for proper surface drainage in an experimental field. True/False

3. A slope is expressed as _____ of rise or fall along a line,
 - a) length in meters
 - b) length in inches
 - c) percentage
 - d) division
4. Slope can be calculated by
 - a) measuring the horizontal distance between two points and multiplying by 100.
 - b) measuring the vertical distance between two points and multiplying by 100.
 - c) dividing the vertical distance by horizontal distance and multiplying by 100.
 - d) dividing the horizontal distance by the vertical distance.

Soil Sampling Procedures

1. Soil samples are taken in a straight line along a row and across the field. True/False
2. To ensure proper sampling, the person should take samples
 - a) across the rows of sowing of a similar soil type.
 - b) along the rows of sowing of an area of similar soil type.
 - c) in a zigzag fashion within each area of similar soil type.
 - d) by none of the above.
3. Soil samples are required because it is impractical or impossible to analyze all soil from a field. True/False
4. Soil sampling is required to study
 - a) the physical characteristics of soil.
 - b) the chemical status of the soil.
 - c) the physical and chemical properties of the soil.
 - d) none of the above.

Laying Out an Experiment

1. To improve the precision of an experiment
 - a) one must have a large area.
 - b) try to take as many treatments as possible.
 - c) increase the replications.
 - d) use only black soils.
2. The size and shape of a field plot are important because
 - a) they influence the time to lay out an experiment.
 - b) they influence the efficiency of farm machinery.
 - c) soil heterogeneity can be accommodated among replications.
 - d) all the above must be considered.
3. The choice of an experimental design will largely depend on the
 - a) number of treatments of the experiment.
 - b) amount of land available.
 - c) amount of manpower available.
 - d) degree of precision required.
4. Uniform conditions while conducting an experiment are essential
 - a) to identify treatment differences.
 - b) to optimize labor operations.
 - c) reduce fertilizer application.
 - d) due to none of the above.

Fertilizers

1. A straight fertilizer is one that
 - a) contains all 3 major nutrients.
 - b) contains only one major nutrient.
 - c) contains only micronutrients.
 - d) contains only filler.

2. Ammonium sulphate supplies
 - a) 28% N.
 - b) 40% N.
 - c) 20% N.
 - d) 10% N.
3. A complex fertilizer supplies
 - a) at least two major nutrients.
 - b) all three major nutrients,
 - c) only one nutrient.
 - d) both a and b above.
4. Triple super phosphate contains
 - a) 7% P.
 - b) 18% P.
 - c) 35% P.
 - d) 20% P.
5. To convert P_2O_5 to P
 - a) multiply by a factor of 2.29.
 - b) multiply by a factor of 1.87.
 - c) multiply by a factor of 0.43.
 - d) use none of the above.
6. If plot size is 5 m x 3 m and rows are 5 m x 0.75 m and a sorghum experiment is to receive 60 kg N and 30 kg P ha^{-1} find the amount of DAP and urea for one plot and one row.

	DAP		Urea	
	plot ⁻¹	row ⁻¹	plot ⁻¹	row ⁻¹
a)	240 g	50 g	109.5 g	27.5 g
b)	259 g	37 g	111.6 g	30.6 g
c)	225 g	56 g	107.5 g	26.8 g
d)	239 g	60 g	112.5 g	31.5 g

Establishing the Required Plant Population

1. If you want to establish the following plant population ha^{-1} , how many plants should there be in rows 10 m long and 0.75 m apart?
Population:
 - a) 80,000 plants row⁻¹
 - b) 100,000 plants row⁻¹
 - c) 120,000 plants row⁻¹
 - d) 150,000 plants row⁻¹
 - e) 180,000 plants row⁻¹
2. An optimal plant population is not required for meaningful data.
True/False
3. A good sorghum seed should have more than _____ % germination.
4. Sowing extra seed may be required to ensure 100% plant establishment.
True/False
5. If plot size is 5 m x 3 m and rows are 5 m x 0.75 m calculate the amount of seed required for one plot and one row when the sorghum seed lot has 90 % germination, the 100-seed mass = 2.7 g, and the plant population is to be 150 000 plants ha^{-1}
 - a) 7 g plot⁻¹ and 2.0 g row⁻¹.
 - b) 6.75 g plot⁻¹ and 1.68 g row⁻¹.
 - c) 6.0 g plot⁻¹ and 1.5 g row⁻¹.
 - d) 6.25 g plot⁻¹ and 1.5 g row⁻¹.

Sowing Procedure

1. It is not essential to sow the seed at a uniform depth under dry conditions.
True/False
2. If the seeds are sown by hand, it is essential that
 - a) seeds are of uniform size.
 - b) a uniform depth is maintained.
 - c) seeds are distributed uniformly.
 - d) both b and c above.
3. Firm compaction after covering the seeds is essential for good seed and soil contact to ensure uniform and rapid seedling emergence.
True/False



Sowing in Different Soil Types

1. In Alfisols, opening and closing the furrow must be done very quickly to conserve moisture. True/False
2. In Vertisols dry seeding is a beneficial practice for early crop establishment. True/False
3. Red soils are usually lighter, hence sowing can be done fairly soon after a rainfall. True/False

Harvesting

1. Harvesting should commence when the grain is thoroughly dry. True/False
2. Sorghum and millet can be harvested when the grains have attained physiological maturity. True/False
3. A yellow layer will be formed at the tip of the cereal grain when physiological maturity has been reached. True/False
4. Harvest all the panicles, place them on the ground, count them, and then put them in the bag. True/False

Answers to evaluation

- Rectangle: 1. False; 2. b; 3. b.
- Area estimation: 1. b; 2. c; 3. c; 4. c; 5. b; 6. d.
- Slope: 1. False; 2. True; 3. c; 4. c.
- Soil sampling: 1. False; 2. c; 3. True; 4. c.
- Laying out an experiment: 1. c; 2. d; 3. d; 4. a.
- Fertilizers 1. b; 2. c; 3. d; 4. d; 5. c; 6. c.
- Establishing plant population: 1. a) 60; b) 75; c) 90; d) 112; e) 135.
2. False; 3. 80%; 4. True; 5. b.
- Sowing procedure: 1. False; 2. b; 3. True.
- Sowing in different soils: 1. True; 2. True; 3. True.
- Harvesting: 1. False; 2. True; 3. False; 4. False.

