

# **Modeling the Growth and Development of Sorghum and Pearl Millet**

**Research Bulletin no.12**

**International Crops Research Institute for the Semi-Arid Tropics**

ICRISAT (International Crops Research Institute for the Semi-Arid Tropics). 1989. **Modeling the Growth and Development of Sorghum and Pearl Millet.** Research Bulletin no. 12. (Virmani, S.M., Tandon, H.L.S., and Alagarwamy, G. eds.). Patancheru, A.P. 502 324, India: ICRISAT.

The 1980s have witnessed substantial increases in food production. This has raised expectations that improved systems of farming will be rapidly adopted by small farmers in developing countries. The agroecological environment of such farms is fragile and the farmers are resource-poor. Therefore, strategies recommended for increasing food production must be ecologically sound and should result in sustainable agriculture.

System modeling can greatly expedite the search for improved development strategies. Recent advances in crop modeling have made it possible to simulate yields and growth of several crops under varied soil and weather conditions with different management practices. This bulletin describes the framework of CERES (Crop Estimation Through Resource and Environment Synthesis) models developed by the International Benchmark Sites Network for Agrotechnology Transfer (IBSNAT) and The International Crops Research Institute for the Semi-Arid Tropics (ICRISAT). Recent work on the simulation of nitrogen transformation in soils at the International Fertilizer Development Center (IFDC) is discussed. A section on risk analyzes the cost-benefit implications of various inputs for increased crop production. RESCAP—a resource capture model developed at ICRISAT Center is presented.

This publication is a cogent source book on the current status of development of CERES and RESCAP models, their data needs, outputs, and applications.

**ISBN-92-9066-174-7**

The International Crops Research Institute for the Semi-Arid Tropics is a nonprofit, scientific, research and training institute receiving support from donors through the Consultative Group on International Agricultural Research. Donors to ICRISAT include governments and agencies of Australia, Belgium, Canada, Federal Republic of Germany, Finland, France, India, Italy, Japan, Netherlands, Norway, Sweden, Switzerland, United Kingdom, United States of America, and the following international and private organizations: Asian Development Bank, Deutsche Gesellschaft für Technische Zusammenarbeit (GTZ), International Development Research Centre, International Fund for Agricultural Development, The European Economic Community, The Opec Fund for International Development, The World Bank, and United Nations Development Programme. Information and conclusions in this publication do not necessarily reflect the position of the aforementioned governments, agencies, and international and private organizations.

The opinions in this publication are those of the authors and not necessarily those of ICRISAT. The designations employed and the presentation of the material in this publication do not imply the expression of any opinion whatsoever on the part of ICRISAT concerning the legal status of any country, territory, city, or area, or of its authorities, or concerning the delimitation of its frontiers or boundaries. Where trade names are used this does not constitute endorsement of or discrimination against any product by the Institute.

**ICRISAT (International Crops Research Institute for the Semi-Arid Tropics). 1989. Modélisation de la croissance et du développement du sorgho et du mil. Bulletin de recherche n° 12. (Virmani, S.M., Tandon, H.L.S. et Alagarwamy, G. eds.) Patancheru, A.P. 502 324, Inde : ICRISAT.**

Pendant les années quatre-vingt, l'augmentation de la production agricole a été importante, ce qui a fait penser que les systèmes de production améliorés seront vite adoptés par les paysans des pays en développement. L'environnement agro-écologique de tels champs est fragile et les paysans ne disposent pas suffisamment de ressources. Ainsi, les stratégies recommandées pour l'augmentation de la production agricole doivent prendre en considération la valeur écologique tout en amenant une agriculture stable.

La modélisation des systèmes pourrait accélérer la recherche des stratégies de développement améliorées. Les progrès récents dans la modélisation des cultures ont rendu possible la simulation des rendements et la croissance de plusieurs cultures sous des conditions variées de sol et de temps avec les pratiques différentes de gestion. Ce bulletin décrit la portée des modèles CERES (Estimation culturale avec la synthèse des ressources et de l'environnement) mis au point par International Benchmark Sites Network for Agrotechnology Transfer (IBSNAT) et l'Institut international de recherches sur les cultures des zones semi-arides (ICRISAT). Le travail récent sur la simulation de la transformation de l'azote dans les sols au Centre international de développement des engrais (IFDC) est aussi discuté. Est incluse également une partie sur le risque et les implications des coûts-bénéfices des intrants différents pour l'augmentation de la production agricole. Le RESCAP, modèle de captage des ressources mis au point à l'ICRISAT, est aussi présenté.



Cette publication constitue une source succincte sur le statut actuel d'élaboration des modèles tels que le CERES et le RESCAP, leurs besoins en données, leurs productions et leurs applications.

# Modeling the Growth and Development of Sorghum and Pearl Millet

Edited by

S.M. Virmani, H.L.S. Tandon, and G. Alagarswamy

Sponsored by

 <p>IBSNAT</p>	<p>International Benchmark Sites Network for Agrotechnology Transfer (IBSNAT)</p>
 <p>ICRISAT</p>	<p>International Crops Research Institute for the Semi-Arid Tropics (ICRISAT)</p>
 <p>IFDC</p>	<p>International Fertilizer Development Center (IFDC)</p>



Research Bulletin no. 12  
International Crops Research Institute for the Semi-Arid Tropics  
Patancheru, Andhra Pradesh 502 324, India

1989

**Scientific Editors**

S.M. Virmani, H.L.S. Tandon, and G. Alagarswamy

**Publication Editor**

Seth R. Beckerman

**Editorial Coordination**

Sarwat Hussain

**Cover Design**

Sheila Bhatnagar

# Contents

	<b>Foreword</b>	1
	<b>Preface</b>	2
<b>Data Base Management Systems (DBMS)</b>	<b>IBSNAT's Decision Support System for Agrotechnology Transfer</b> Upendra Singh	3
	<b>Use and Applications of Data Base Management Systems</b> Upendra Singh and G. Alagarswamy	5
	<b>Discussion</b>	7
<b>Nitrogen in Soils</b>	<b>Simulation of Nitrogen Transformation in Soil</b> D.C. Godwin	8
	<b>Modeling Nitrogen Uptake and Response in Sorghum and Pearl Millet</b> G. Alagarswamy, Upendra Singh, and D.C. Godwin	11
	<b>Discussion</b>	13
<b>Soil Water Balance and Weather Generation</b>	<b>Description of Soil Water Balance</b> J.T. Ritchie and D.C. Godwin	14
	<b>Obtaining Soil Input for the CERES Model</b> J.T. Ritchie and D.C. Godwin	16
	<b>Weather Generator Program</b> D.C. Godwin	18
	<b>Discussion</b>	20
<b>Valuation of Risks to Crop Production</b>	<b>Risk Analysis</b> D.C. Godwin and Upendra Singh	21
	<b>Discussion</b>	23
<b>Physiology of Sorghum and Pearl Millet</b>	<b>Simulation of Sorghum and Pearl Millet Phenology</b> J.T. Ritchie and G. Alagarswamy	24
	<b>Genetic Coefficients for the CERES Models</b> J.T. Ritchie and G. Alagarswamy	27
	<b>Discussion</b>	29
<b>Modeling Sorghum and Pearl Millet</b>	<b>RESCAP: A Resource Capture Model for Sorghum and Pearl Millet</b> J.L. Monteith, A.K.S. Huda, and D. Midya	30
	<b>Simulation of Growth and Development in CERES Models</b> J.T. Ritchie and G. Alagarswamy	34
	<b>Discussion</b>	39
<b>Conclusion</b>	<b>Models, Software, and Documentation</b> J.T. Ritchie, J.L. Monteith, D.C. Godwin, and A.K.S. Huda	40
	Participants	41
<b>Glossaries</b>	<b>CERES Glossary, RESCAP Glossary</b>	44

# Foreword

In 1982, an international group of agricultural and system scientists met at ICRISAT to define the minimum data set required to simulate crop growth and development. The aim was to develop a solid foundation for research dealing with the soil-plant-atmosphere continuum, and to encourage strong links between scientists who study the biophysical and socioeconomic components of the agroecosystem. The scope of work was limited to 10 food crops, including four cereals (maize, rice, sorghum, and wheat), three grain legumes (dry beans, groundnut, and soybean), and three root crops (aroid, cassava, and potato). Barley and pearl millet were later added to the list.

The conference participants wrote two reports. The first, *Minimum Data Sets for Agrotechnology Transfer*, was published by ICRISAT, and the second, *Experimental Design and Data Collection Procedures: the minimum data set for systems analysis and crop simulation*, was published by IBSNAT. The latter publication has been revised twice, and continues to serve as a guide for designing field experiments to validate models. Subsequently, the group decided there was a need to standardize the input and output format of existing crop models so that they all accessed a common data base and application program. This eventually led to a plan to combine the data base, crop models, and application programs into a Decision Support System for Agrotechnology Transfer (DSSAT).

Version 2.0 of DSSAT used in this workshop enables users to easily access soil, weather, and crop data bases, crop models, and application programs to evaluate alternative strategies to attain desired outcomes. It was developed through the combined efforts of scientists from many countries, and international and regional agricultural research centers. DSSAT is still being developed and users can expect it to become more versatile and reliable in the years ahead. To do so, DSSAT will need continued input from current and new collaborators so that the existing global knowledge base can be captured, organized, and retrieved for solving site and situation-specific problems. The sorghum and pearl millet modeling workshop is one step in this direction.

Honolulu,  
March 1989

**Goro Uehara**

## Preface

In recent years, crop models have advanced from restricted academic exercises to tools with potential for wide applications in agriculture. Builders of the CERES series of models, for example, aim at predicting the yield of any genotype, in any soil, at any location, and in any weather.

One of ICRISAT's mandates is to identify constraints to agricultural development in the semi-arid tropics and evaluate means of alleviating them. Another is to assist in the development and transfer of technology by sponsoring workshops, conferences, and training programs. It was thus appropriate that ICRISAT, in cooperation with IBSNAT and IFDC, hosted the training workshop on sorghum and pearl millet modeling.

The aim was to familiarize and train agricultural researchers in the principles and operational aspects of crop modeling, and obtain feedback about the potential and limitations of current models.

In an evaluation of the workshop conducted by ICRISAT's Training Program, a majority of the participants gave high marks to the workshop. About two-thirds of the respondents said the number of handouts should be increased, and almost all felt that they had benefited from the computer exercises. Exposure to modeling, hands-on computer time working with models, and understanding subroutines were identified as the areas of greatest benefit.

Participants anticipated continued contact with workshop organizers through updates and documentation. They felt there should have been more computer time, more printers and visual aids, more time to discuss group findings from hands-on exercises, and provision of computer manuals and documentation before the workshop.

Summaries of the papers, discussions, and a list of documents distributed during the workshop are provided in this report. The Resource Management Program of ICRISAT, along with IBSNAT and IFDC, welcomes comments or requests for detailed information.

The work of the organizing committees of the three collaborating institutions was marked by a constructive spirit. Considerable assistance was received from G. Uehara, T. Tsuji, and J.T. Ritchie representing IBSNAT; D.C. Godwin, L.L. Hammond, and P.L.G. Vlek of IFDC in program planning and the identification of potential participants; and B.C.G. Gunasekera, S.M. Virmani, J.R. Burford, J.W. Estes, J.M. Peacock, D.L. Oswalt, G. Alagarswamy, T.J. Rego, and A.K.S. Huda from ICRISAT in helping to define the objectives and making the preparations for the workshop. Their advice and guidance is appreciated. Finally, thanks are due to S.M. Virmani for conceptualizing and coordinating the workshop so efficiently.

ICRISAT  
March 1989

**J.L. Monteith**

# Data Base Management Systems (DBMS)

## IBSNAT's Decision Support System for Agrotechnology Transfer

Upendra Singh

A decision-making system consists of a user who utilizes a system to carry out a task in a given environment. The components of a decision support system are:

- a data base;
- a model base; and
- a control program.

The dialogue generator links the user to each of the above. The system is designed to define, organize, process, and retrieve information in a way that is useful to the user. The decision support system is intended to provide information effectively and efficiently. Much of the power and flexibility of the system is derived from the interaction between the system and the user.

The Decision Support System for Agrotechnology Transfer (DSSAT) developed by IBSNAT is a computerized system to help resource planners and farmers make decisions as they seek solutions to specific agricultural problems. These include resource allocation, land use planning, and environmental protection. It can predict, diagnose problems, and prescribe appropriate solutions. As an educational tool, it helps users understand agricultural systems and provides an opportunity to explore important biological, physical, and chemical relationships in agriculture.

DSSAT provides convenient access to soil, crop, and climatic data bases; crop simulation models; weather generators; expert systems; strategy evaluation; and utility programs for formatting, retrieving, and graphing information. Crop models, weather generators, expert systems, and strategy analyses form the knowledge base of DSSAT. DSSAT's modular structure (Fig. 1) and standardized input-output format lend themselves to incorporation of new models and expert systems to accommodate an expanding knowledge base.

The most important component of DSSAT is the data base, which stores the minimum data set (MDS) for soil, crop, management, and weather data from collaborators around the world. The convenient, interactive, and efficient access to these data facilitates the development, modification, and validation of crop models, expert systems, and weather generators.

Validation is the cornerstone of evaluation. It ensures that models perform correctly when tested against observed data. Validated models can be used to reliably simulate crop yields and other output variables in different environments. Simulated results from many years of real-time or generated weather can be used to estimate yield variability and risk under alternative management options.

It is envisioned that new models which describe the effects of nutrients other than nitrogen, pests and pesticides, groundwater quality, farming systems, and socioeconomic variables will appear within the foreseeable future, and can be accommodated as DSSAT is further developed. In addition, statistical analysis and other evaluation programs for model validation, weather generators, and expert systems can be easily coupled to DSSAT.

With the inclusion of nutrient, pest, and farming systems models, DSSAT will be able to facilitate the design of agrotechnology packages better suited to resources and farmer objectives. The ultimate objective of DSSAT is to improve the decision-making ability of farmers.



User interface	Control program	
	Knowledge base	Crop growth models CERES Maize CERES Wheat CERES Rice CERES Sorghum CERES Pearl Millet CERES Barley SOYGRO PNUTGRO
		Socioeconomic analysis Strategy evaluation
		Weather generators Richardson Hargreaves
		Expert Systems ACID4
		Pest models
	Data Base Management System	Data entry and retrieval Soil data base Cultivar data base Experiment data base Daily weather data Fertilizer data base
	Utility	Print forms Format conversion Setup Summary

**Figure 1. Structure of Data Support Systems for Agrotechnology Transfer (DSSAT).**

# Use and Applications of Data Base Management Systems

Upendra Singh and G. Alagarswamy

A data base management system (DBMS) is designed to organize and store data, provide user-friendly data entry and retrieval programs, and integrate data from several sources into a computerized system. It also provides an interface between the data base and specific application programs with a control program, usually referred to as a data base processing system. A well-designed DBMS occupies as little disk space as possible, can be quickly searched, indexed or queried, and answers users' questions easily, including those that its designers had not anticipated. It also helps users avoid data errors, and provides a means to check and account for data integrity. In order to be effective, a DBMS requires a symbiosis between the users and the system.

The DBMS component of DSSAT is a relational data base. Thus, the information needed to support agrotechnology transfer functions is stored in a group of related data base files. These files store data on site weather, experimental details, soil pedon, profile description, and crop-specific genetic coefficients. The coded forms (A-S) in IBSNAT Technical Report 1 (1988) describe these and data collection methods. The files are related by common key index fields in such a way that data can be retrieved as required. The key indices used are crop identification (ID), institute ID, site ID, and experiment ID. Together the related data base files function as a larger data base, and reduce redundancy (Fig. 1).

The advantages of relational DBMSs become evident when considering weather data files. The weather data are filed separately from experimental data because the same weather station data can be used for more than one experiment at the same site. Separate storage conserves computer memory and disk space. Several years of weather data collected at one site is easily accessible, allowing models to be tested under varying climatic conditions. This also allows creation of weather coefficients for weather generators, and to perform long-term simulation experiments. Every experimental data set can be rejoined to its weather station data set when required for crop simulation, since it is cross-indexed by site and weather ID codes, and duration of experiment. A similar functional relationship exists between experimental and soil data.

One major application of the minimum data set (MDS) stored in the DBMS is testing the performance of crop models. Model-specific input data files and validation files are created by retrieving the MDS from the data base (Fig. 1). Other applications are: statistical analysis, plotting results, input to expert systems, input to site-specific models, etc. The DBMS program also provides output on weather, experiment, and soil inputs; graphic display of weather inputs; utility programs for updating old versions of DBMS and MDS forms; and converting weather and harvest data from ASCII to MDS format. As illustrated in Figure 1, all the files (directory, input, and validation data) needed for simulating crop growth are simulated by the DBMS.

## Reference

**IBSNAT (International Benchmark Sites Network for Agrotechnology Transfer).** 1988. Experimental design and data collection procedures for IBSNAT: the minimum data set for systems analysis and crop simulation. 3rd edn. Technical Report 1. Honolulu, HI, USA: IBSNAT. 74 pp.

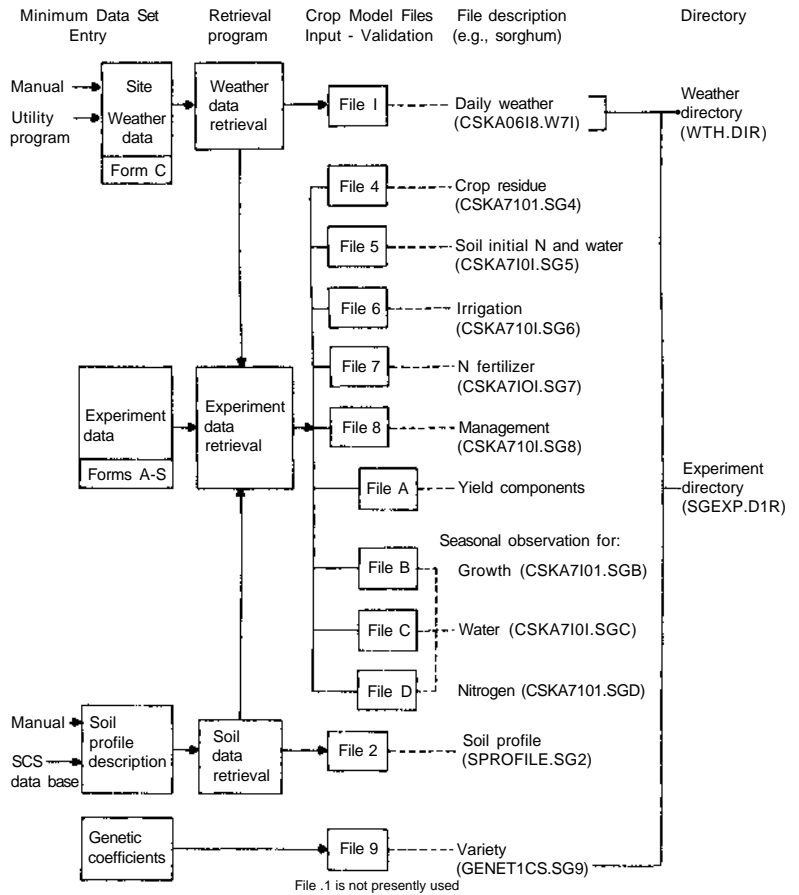

Figure 1. Schematic representation of a data base management system (DBMS).

## Discussion

In the discussion following the presentations, the importance of model validation was stressed. Model validation evaluates whether or not a model predicts correct results. Questions from the participants centered around terminology, and stressed the need to clarify the terms validation, verification, calibration, and corroboration.

Validation was explained as the process of building the right system, i.e., the system output clearly represents the real situation being modeled.

Verification refers to the mechanics of model building, and the correctness of the computations within the model.

Calibration is the process of modifying certain model parameters to more closely reflect local weather and soil conditions, etc.

Finally, corroboration refers to the testing of the predictive capability of a model by an independent third party.

It was agreed that IBSNAT would be requested to publish standard definitions of these terms to be used in all future modeling projects and workshops.

It was stressed that having a model does not mean that experimentation stops. Rather, experiments must still be performed, and real measurements must be compared with simulated measurements, so that models can be perfected. Simulated measurements cannot always be the same as real measurements, since a change in a single factor can produce different results. This was demonstrated by photographs of the same crop sown on the same day at locations at three different elevations.

The main areas of application of DSSAT were:

- research, where it forms a framework for setting priorities and guiding research, and helps evaluate the potential of agrotechnology;
- training, where it can present and reinforce concepts and principles of agrotechnology, demonstrate the application of biological processes, and provide the basis for computer-designed laboratory exercises; and
- extension, where it provides a basic structure for extension of knowledge.

The need for a minimum data set, the basic data required for models to work properly, was stressed. Different computer-based forms for entering data into DSSAT were demonstrated.

# Nitrogen in Soils

## Simulation of Nitrogen Transformation in Soil

D.C. Godwin

The nitrogen (N) component of the model is designed to operate as a component of the CERES models and not in a stand-alone mode. The soil N submodel describes the processes of mineralization and/or immobilization of N associated with the decay of crop residues, nitrification, denitrification, urea hydrolysis, leaching of nitrate, and the uptake and utilization of N by the crop. It utilizes the layered soil water balance model described in this publication and a simple soil temperature subroutine. The soil N model comprises two subroutines describing N movement, and soil N transformations. Additional subroutines are used for input and output of data and for the initialization of the various N pools.

### Movement of Nitrate and Urea

Ammonium is assumed not to be transported across soil layers. Only the movement of nitrate and urea is considered. The same procedures for simulating nitrate movement are used for urea movement. Nitrate movement in the soil profile is dependent upon water movement. In the water balance component of the model, the volume of water moving from a layer (L) to the layer below [FLUX(L)] is calculated. The volume of water present in the layer before drainage occurred is also calculated from the volumetric water content [SW(L)] and the depth of the layer [DLAYR(L)]. Nitrate lost from each layer (NOUT) is then calculated as a function of the water which is retained and that which is moved.

$$\text{NOUT} = \text{SN03(L)} * \text{FLUX(L)} / (\text{SW(L)} * \text{DLAYR(L)} + \text{FLUX(L)}) \quad (1)$$

SN03(L) = quantity of nitrate present in layer L ( $\text{kg N ha}^{-1}$ )-

A simple cascading approach is used where the nitrate lost from one layer is added to the layer below. When the concentration of nitrate in a layer falls to  $1.0 \mu\text{g NO}_3 \text{g}^{-1}$  of soil, no further leaching from that layer is allowed to occur. Most of the differences in simulated nitrate leaching rate between soils of different texture is explained by the difference in proportion of water which is mobile.

Similar procedures are used to simulate the rate of upward movement of nitrate and urea with evaporation of water from the surface layers. In this case the water balance routine calculates the upward flow of water [FLOW(L)] and the amount of upward movement (NUP) is calculated as for NOUT.

$$\text{NUP} = \text{SN03(L)} * \text{FLOW(L)} / (\text{SW(L)} * \text{DLAYR(L)} + \text{FLOW(L)}) \quad (2)$$

### Fertilizer Additions and Urea Hydrolysis

Fertilizer N is partitioned in the model between amide, nitrate, and ammonium pools, according to the nature of the fertilizer used. The assumption is that N is uniformly incorporated into the soil layer into which it is placed. Surface N applications are treated as being uniformly incorporated into the top layer. Up to 10 split applications can be accommodated by the model.

To simulate urea hydrolysis, a maximum hydrolysis rate is estimated from the soil organic carbon and pH. The temperature and soil water indices are designed to simulate the effects of soil moisture and temperature.

### Mineralization and Immobilization

A balance exists between the two processes of mineralization and immobilization. When crop residues with a high C:N ratio are added to soil, the balance can shift towards net immobilization for a period of time. After some of the soil carbon has

been consumed by respiration, net mineralization may resume. Nitrogen mineralized from the soil organic pool often constitutes a large part of the N available to the crop.

In the case of residues having a high C:N ratio (e.g., freshly incorporated wheat straw), the N available for the decay process will greatly limit the decay rate. For each of the fresh organic matter (FOM) pools a decay rate appropriate for that pool (JP) can be calculated by multiplying the rate constant by the three indices.

$$GI = TF * MF * CNRF * RDECR(JP) \quad (3)$$

where

G1 = the proportion of the pool which decays in one day,

TF = temperature factor,

MF = moisture factor, and

CNRF = carbon to nitrogen ratio factor.

The amount of material decayed is then the product of G1 and the pool size. The gross mineralization of N associated with this decay (GRNOM) is then calculated according to the proportion of the pool which is decaying.

$$GRNOM = GI * FPOOL(L,JP) / FOM(L) * FON(L) \quad (4)$$

where

FPOOL(L,JP) = pool of either carbohydrate (JP = 1), cellulose (JP = 2), or lignin (JP = 3) present in layer L ( $\mu\text{g ha}^{-1}$ ); and

FON = fresh organic nitrogen.

GRNOM is summed for each of three pools in each layer. Similarly, the amount of organic matter decaying (GRCOM) is determined as the sum of three pool fractions.

The procedure used for calculating the N released from the humus (RHMIN) also utilizes TF and MF. In this case CNRF is not used and the potential decay rate constant (DMINR) is very small ( $8.3E - 5.0$ ). DMOD is a zero to unity factor for adjusting the mineralization rate on unusual soils. Except for certain volcanic ash and freshly cultivated virgin soils, a value of 1.0 is used for DMOD. Satisfactory alternatives for estimating DMOD are currently being sought. RHMIN is the product of the various indices and the N contained within the humus [NHUM(L)].

$$RHMIN = NHUM(L) * DMINR * TF * MF * DMOD \quad (5)$$

These calculations also allow for the transfer of 20% of the gross amount of N released by mineralization of FON(L) to be incorporated into NHUM(L). This accounts for N incorporated into microbial biomass (Seligman and van Keulen 1981). The N which is immobilized into microbial biomass during decay process (RNAC) is calculated as the minimum of the soil extractable mineral N (TOTN) and the demand for N by the decaying FOM(L).

$$RNAC = AMINI(TOTN, GRNOM * [0.02 - FON(L) / FOM(L)] \quad (6)$$

where

AMIN1 is a Fortran library function to select the minimum of those variables in parentheses, and 0.02 is the N requirement for microbial decay of a unit of FOM(L). The value of 0.02 is the product of the fraction of C in the FOM(L) (40%), the biological efficiency of C turnover by the microbes (40%) and the N:C ratio of the microbes (0.125). FOM(L) and FON(L) are then updated:

$$FOM(L) = FOM(L) - GRCOM \quad (7)$$

$$FON(L) = FON(L) + RNAC - GRNOM \quad (8)$$

In CERES models four pools of organic matter are considered. First, fresh organic matter (FOM) derived from crop residues is partitioned into three pools—carbohydrate, cellulose, and lignin. The fourth organic N pool is derived from stable organic matter or humus. For each of the FOM pools a decay rate can be calculated by multiplying a constant rate by three indices. The indices describe the limitations on

decay rate imposed by moisture, temperature, and C:N ratio of the material. The balance between RNAC and GRNOM determines whether net mineralization or immobilization occurs. The net N released from all organic sources (NNOM) is:

$$\text{NNOM} = 0.8 * \text{GRNOM} + \text{RHMIN} - \text{RNAC} \quad (9)$$

Only 80% of GRNOM enters this pool since 20% was incorporated into NHUM(L). NNOM can then be used to update the ammonium pool [SNH4(L)].

$$\text{SNH4(L)} = \text{SNH4(L)} + \text{NNOM} \quad (10)$$

If net immobilization (NNOM negative) occurs, ammonium is first immobilized. If there is not sufficient ammonium to retain this pool with a concentration of 1  $\mu\text{g}$ , then withdrawals are made from the nitrate pool.

## Nitrification

The potential nitrification rate is a Michaelis-Menten kinetic function dependent only on ammonium concentration and is thus independent of soil type. The approach used in the CERES models has been to calculate a potential nitrification rate and a series of zero to unity environmental indices to reduce this rate. A further index, termed a "nitrification capacity" is used to introduce a lag effect on nitrification if conditions in the last 2 days have been unfavorable for nitrification. Actual nitrification capacity is calculated by reducing the potential rate by the most limiting of the environmental indices and the capacity index.

The approach adopted in the CERES models has been to adapt the functions described by Rolston et al. (1980) to fit within the framework of the model and to match inputs derived from the water balance and mineralization components of CERES models.

Denitrification calculations are only performed when the soil water content (SW) exceeds the drained upper limit (DUL). A zero to unity index (FW) for soil water in the range from DUL to saturation (SAT) is calculated.

$$\text{FW} = 1.0 - [\text{SAT(L)} - \text{SW(L)}] / [\text{SAT(L)} - \text{DUL(L)}] \quad (11)$$

A factor for soil temperature is also calculated

$$\text{FT} = 0.1 * \text{EXP}[0.046 * \text{ST(L)}] \quad (12)$$

Soil soluble carbon provides the energy for denitrification. This is estimated from organic carbon and fresh residues. Denitrification rate (DNRATE) is calculated from the nitrate concentration and converted to a  $\text{kg N ha}^{-1} \text{ day}^{-1}$  basis for the mass balance calculations.

$$\text{DNRATE} = 6.0 * 1.0\text{E} - 5.0 * \text{CW} * \text{N03(L)} * \text{FW} * \text{FT} * \text{DLAYR(L)} \quad (13)$$

where

DLAYR(L) = depth of layer L (cm),

FT = temperature factor effect on denitrification (unitless),

FW = water factor effect on denitrification (unitless),

N03(L) = nitrate concentration in layer L ( $\mu\text{g N g}^{-1}$  soil), and

CW = total water-extractable carbon in the soil layer ( $\mu\text{g C g}^{-1}$  soil).

## References

**Rolston, D.E., Sharpley, A.N., Toy, D.W., Hoffman, D.L., and Broadbent, F.E. 1980.** Denitrification as affected by irrigation frequency of a field soil. EPA-600/2-80-66. Ada, Oklahoma, USA: U.S. Environmental Protection Agency, pp 58.

**Seligman, N.C., and van Keulen, H. 1981.** PAPRAN: a simulation model of annual pasture production limited by rainfall and nitrogen. Pages 192-221 *in* Simulation of nitrogen behaviour of soil-plant systems (Frissel, M.J., and van Veen, J.A., eds.). Wageningen, Netherlands: PUDOC (Centre for Agricultural Publishing and Documentation).

# Modeling Nitrogen Uptake and Response in Sorghum and Pearl Millet

**G. Alagarswamy, Upendra Singh, and D.C. Godwin**

Plant growth is greatly affected by the supply of nitrogen (N) fertilizer. The CERES models have procedures for simulating the uptake of N and its subsequent utilization by the crop. The routines are designed to operate in conjunction with the remainder of the CERES model and thus cannot be run alone. Information from the water balance, growth, and phenology routines, as well as information on the nitrogen balance, is supplied from the whole CERES model to the N uptake and plant N routines. N uptake is simulated in one subroutine and plant N stress indices are calculated in a separate subroutine. The N stress indices together with indices describing drought stress are used within the growth simulation component of the model to modify the rates of various plant growth processes. The two plant N subroutines operate on a daily time step, as does the remainder of the model.

## Critical N Concentration in Plant and Deficit Factor

Typically the supply of N to plants at the beginning of the season is relatively high and becomes lower as the plant reaches maturity. During early growth, N concentrations are usually high due to the synthesis of large amounts of organic N compounds required by the growth process. As the plant ages, less of this material is required and translocation from old tissues to new tissues occurs, lowering the whole plant N concentration. At any point, there exists a critical N concentration in the aerial plant tissue (TCNP) and in roots (RCNP), below which growth will be reduced. The critical concentration is defined as the concentration below which N deficiency will have some effect on plant growth. Concentrations can exceed the critical concentration when luxury consumption occurs but this does not further enhance the growth rate. A function describing the change in critical N concentration with increasing plant age is used to simulate N deficiency effects on plant growth.

The critical and minimum concentrations are used to define a nitrogen factor (NFAC) which ranges from zero to slightly above unity. NFAC is the primary mechanism used within the model to determine the effect of N on plant growth. It is an index of N deficiency relating the actual concentration in aerial plant parts (TANC) to these critical concentrations. NFAC has a value of zero when TANC is at its minimum value (TMNC) and increases to 1.0 as concentration increases toward the critical level. Since all plant growth processes are not equally affected by N stress, a series of indices based on NFAC are used.

### Index Effect described

- NDEF1 Effect of N-deficiency on photosynthesis per unit leaf area.
- NDEF2 Effect of N-deficiency on rate of leaf area expansion and leaf senescence.
- NDEF3 Effect of N-deficiency on tillering.
- NDEF4 Modification in rate of grain N accumulation.

A maximum NFAC value implies that when TANC exceeds TCNP no extra growth occurs. In the growth component of the models, these indices together with similarly defined zero to unity indices for soil drought stress are used to reduce potential rates of the growth processes. The more limiting of either drought or nitrogen stress is selected in each case to modify the process.

## Nitrogen Uptake

The components of crop demand for N and the soil supply of N are calculated separately, and then the lesser of the two is used to determine the actual rate of uptake. Demand for N has two components. First there is a "deficiency demand." This is the amount of N required to restore TANC to TCNP. This deficiency demand can be quantified as the product of the existing biomass and the concentration difference:



$$\text{TNDEM} = \text{TOPWT} * (\text{TCNP} - \text{TANC}) \quad (1)$$

**where**

TNDEM = plant tops N demand (kg N ha<sup>-1</sup>)

TOPWT = weight of aerial plant parts (kg ha<sup>-1</sup>).

Similarly, for roots the discrepancy in concentration (difference between RCNP and RANC) is multiplied by the root biomass (RTWT) to calculate the root N demand (RNDEM).

$$\text{RNDEM} = \text{RTWT} * (\text{RCNP} - \text{RANC}) \quad (2)$$

If luxury consumption of N has occurred such that TANC is greater than TCNP then these demand components have negative values. If total N demand is negative then no uptake is performed on that day. As biomass increases with crop growth, plant N concentration falls. Thus, when TANC is greater than TCNP, a period of growth will generally cause TANC to fall toward or below TCNP.

The second component of N demand is the demand for N by the new growth. It is assumed that the plant would attempt to maintain a critical N concentration in the newly formed tissues. To calculate the new growth demand, a potential amount of new growth is first estimated in the GROSUB subroutine. New growth is estimated from potential photosynthesis. This potential growth increment provides a mechanism for TANC to exceed TCNP. This occurs when some stress prevails, and the actual growth increment is less than the potential.

During the early stages of plant growth the new growth component of N demand will be a large proportion of the total demand. As the crop biomass increases, the deficiency demand becomes the larger component. During grain filling, the N required by the grain is removed from the vegetative and root pools to form a grain N pool. The resultant, lowered concentration in these pools may lead to increased demand. The total plant N demand is the sum of all of these demand components.

To calculate the potential supply of N to the crop, zero to unity availability factors for both nitrate and ammonium are calculated from the soil concentrations of their respective ions. A zero to unity soil water factor which reduces potential uptake is calculated as a function of the relative availability of soil water.

The maximum potential N uptake from a soil layer may be calculated as a function of the maximum daily uptake per unit length of root, and the total amount of roots present in the layer. The calculation used integrates the effects of root length density, the soil water factor described above, and the depth of the layer. The effect of ion concentration and the maximum uptake per unit length of root are also incorporated into the calculation.

Potential N uptake from the whole profile (TRNU) is the sum of potential nitrate and potential ammonium uptake from each soil layer where roots occur. Thus TRNU represents an integrated value which is sensitive to rooting density, the concentration of the two ionic species, and their ease of extraction as a function of the soil water status of the different layers. This method of determining potential uptake enables the condition of nutritional drought to be simulated. Nutritional drought occurs when nutrients and roots are concentrated in the upper layers of the soil profile, but sufficient water for growth and uptake is present only in the lower layers.

If TRNU is greater than the crop N demand (ANDEM), an N uptake factor (NUF) is calculated and used to reduce the N uptake from each layer to the level of demand.

$$\text{NUF} = \text{ANDEM} / \text{TRNU} \quad (3)$$

This could occur when plants are young and have a high N supply. If the demand is greater than the supply, then NUF has a value of 1.0, When NUF is less than 1.0, uptake from each layer is reduced. Following uptake, concentrations of N in both the shoots and roots are updated. Partitioning of the N taken up between shoot and root parts occurs on the basis of the proportions of the total plant demand arising from shoots and roots, respectively.

## Discussion

The presentations generated a discussion that reflected the importance on N in crop production. A doubt was raised about assuming that all the reactions in the N cycle (mineralization, immobilization, etc.) are continuously occurring in the soil. It was explained that all the measurements for simulating N behavior are on a daily rate basis in which the previous day's history is considered to simulate events of the following day.

Regarding the effect of root exudates on N mineralization and its availability to plants, it was pointed out that its occurrence and magnitude is poorly understood. A suggestion was made for verifying the N mineralization rate by actual crop uptake of N from unfertilized plots and measured N mineralization rates, which was agreed.

The use of law of minimum for urea hydrolysis rather than the multiplicative approach (used for mineralization) was questioned. It was stated that there was a need to be uniform in computing different aspects of the N cycle. Questions were also raised about the decomposition of soil organic matter in the top soil layer when the soil is dry and desiccated. One opinion was that ammonification may continue at a very slow rate under such conditions, but nitrification may not occur because of high temperature. It was also mentioned that the N mineralization rate was slower at soil saturation. It was suggested that the base for validating nitrogen transformation for concept formation should be further enlarged. A suggestion was also made to account for the interactions among several factors.

Replies to other questions provided these details of the model:

When integrating the effects of temperature and moisture on urea hydrolysis, urea hydrolysis is computed on a daily rate basis because plant growth is modeled on a daily basis.

In a situation where nitrate could either be leached or denitrified, and whether it is counted in both processes or not, water in the model moves through the soil layers and leaches nitrates, after which mineralization and other processes are considered, in that order. The model at present ignores N losses through ammonia volatilization.

The model assumes that N is available as  $\text{NH}_4$  and  $\text{NO}_3$ , and does not distinguish between the two. In response to the question of why mass flow influence on nitrate had not been considered, it was stated that uptake is simulated by root growth and root loss. Mass flow and diffusion as such are not considered for uptake.

There was a good discussion on the effects of photosynthesis on leaf area expansion. It was stated that the rate of leaf area expansion depends on photosynthesis, and while the effect of N on crop phenology was not clear, it may not be large, like that of phosphorus. It was also suggested that the reduced leaf expansion helps to maintain N requirement.

The model makes no provision to account for the loss of N through plant foliage, but leaf senescence is considered a function of stress. When partitioning N between the main and secondary tillers, the main tiller gets the N first, with remaining N sent to the secondary tillers.

# Soil Water Balance and Weather Generation

## Description of Soil Water Balance

**J.T. Ritchie and D.C. Godwin**

In CERES models, the soil water balance is calculated to evaluate possible yield reductions caused by soil and plant water deficits. The model evaluates the soil water balance of crop or fallow land using the equation:

$$S = P + I - EP - ES - R - D \quad (1)$$

**where**

S = the quantity of soil water,

P = precipitation,

I = irrigation,

EP = evaporation from plants,

ES = evaporation from soil,

R = runoff, and

D = drainage from the profile.

The soil water is distributed in up to 10 layers, with depth increments specified by the user.

Water content in any soil layer can be decreased by soil evaporation, root absorption, or flow to an adjacent layer. The limits to which water can increase or decrease are inputs for each soil layer as the lower limit of plant water availability, the drained upper limit, and the saturated limit. The values used for these limits must be appropriate to the soil, and accurate values are important in situations where the water input supply is marginal. The traditional laboratory-measured wilting point and field capacity water contents have frequently proved inaccurate for establishing field limits of water availability (Ritchie 1981). Thus field-measured limits are needed for a high level of accuracy.

### **Infiltration and Runoff**

Daily precipitation amounts, and dates of irrigation if used, are input from the weather and irrigation files. Water infiltration into the soil is calculated as the difference between precipitation or irrigation and runoff. Runoff is calculated using the curve number technique as described by the USDA-Soil Conservation Service (SCS). It uses total precipitation occurring in a calendar day to estimate runoff. Runoff curves are specified by numbers which vary from 0 (no runoff) to 100 (all runoff). The SCS handbook provides a list of runoff curve numbers for various hydrologic soil groups and soil-cover complexes. The SCS technique considers the wetness of the soil, calculated from antecedent rainfall amounts, as an additional variable in determining runoff amount. The technique has been modified for layered soils as used in CERES models. The wetness of the soil in the layers near the surface replaces the antecedent rainfall condition. This modified procedure is considered by hydrologists to be one of the most conservative models of runoff when only daily precipitation is known.

When irrigation water is applied, the runoff estimation procedure is bypassed. Thus, all irrigation is assumed to infiltrate.

### **Drainage**

Because water can be taken up by plants while drainage is occurring, the drained upper limit soil water content is not always the appropriate upper limit of soil water

availability. Many productive agricultural soils drain quite slowly, and may thus provide an appreciable quantity of water to plants before drainage practically stops. In CERES models, drainage rates are calculated using an empirical relation that evaluates field drainage reasonably well.

The drainage formula assumes a fixed saturated volumetric water content (SAT), and fixed drained upper limit water content (DUL). Thus drainage takes place when the water content (SW) is between those two limits. The equation is:

$$\text{DRAIN} = \text{SWCON} * (\text{SW} - \text{DUL}) * \text{DEPTH}, \text{SW} > \text{DUL} \quad (2)$$

or

$$\text{DRAIN} = 0, \text{SW} < \text{DUL} \quad (3)$$

**where**

SWCON = drainage coefficient

DEPTH = the thickness of the soil layer being considered, and

SW = the current water content of the layer.

In the model, constant drainage for one day is assumed and the value SWCON represents the fraction of water between DUL and SW that drains in one day.

## Evapotranspiration

Evapotranspiration (ET) is calculated using procedures described by Ritchie (1972). The procedure separates soil evaporation (ES) from transpiration (EP) for plants growing without a shortage of soil water. Potential ET is calculated using an equilibrium evaporation concept, for which a relatively simple empirical equation was developed. The equation calculates the approximate daytime net radiation and equilibrium evaporation, assuming that stomata are closed at night and no ET occurs. Potential ET is calculated as the equilibrium evaporation multiplied by 1.1 to account for the effects of unsaturated air. The multiplier is increased above 1.1 to allow for advection when the maximum temperature is greater than 35°C, and reduced below 1.1 for temperatures below 7°C to account for the influence of cold temperatures on stomatal closure.

The calculation of ES when the soil is drying in the original model (Ritchie 1972) was altered for CERES models to further reduce ES when the soil water content in the upper layer reaches a fixed, low-threshold value. This modification was needed to prevent the surface soil from drying too much when roots are also removing water near the surface.

## Root Water Absorption

The CERES model calculates root water absorption using an approach in which the larger of the soil or the root resistance determines the maximum possible flow rate of water into roots. The soil-limited water absorption rate considers radial flow to single roots as a function of soil hydraulic conductivity, an assumed daily averaged constant water potential between root surface and the bulk soil, an assumed constant root radius, and the root length density. The hydraulic conductivity is normalized for all soils by assuming a constant value of  $5 * 10^{-6} \text{ cm d}^{-1}$  at the lower limit water content. For water content values above the lower limit, the conductivity increases exponentially in proportion to the product of a soil texture dependent coefficient and the water content above the lower limit value. The maximum daily absorption rate is assumed to be  $0.03 \text{ cm}^3 \text{ cm}^{-1}$  of root. The soil- or plant-limited maximum absorption rate is then converted to an uptake rate for an individual soil layer using the root length density and the depth of the soil layer. Root length density and distribution in the soil are estimated in CERES models on the basis of soil properties and the amount of assimilate partitioned to roots. The sum of the maximum root absorption from each soil depth gives the maximum possible uptake from the profile. If the maximum uptake exceeds the maximum calculated transpiration rate, the maximum absorption rates calculated for each depth are reduced so that the uptake becomes equal to the transpiration rate. If the maximum uptake is less than the maximum transpiration, transpiration rate is set equal to the maximum absorption rate.

We recognize that a weak part of CERES, and of crop models in general, is the estimation of the dynamics of root growth in the soil. Some assumptions that are difficult to verify experimentally have to be used to simulate root growth patterns. The growth patterns depend on soil physical and chemical properties, the amount of assimilate transported to the roots, and soil water content. More quantitative root growth information is needed before major improvement can be made in the root growth part of CERES models. Greater details on the water balance model are reported in Ritchie (1985).

## References

**Ritchie, J.T. 1972.** Model for predicting evaporation from a row crop with incomplete cover. *Water Resources Research* 8:1204.

**Ritchie, J.T. 1981.** Soil water availability. *Plant and Soil* 58:327-338.

**Ritchie, J.T. 1985.** A user-orientated model of the soil water balance in wheat. Pages 293-305 *in* *Wheat growth and modeling* (Day, W., and Atkin, R.K., eds.). New York, USA: Plenum.

# Obtaining Soil Input for the CERES Model

**J.T. Ritchie and D.C. Godwin**

## Single Profile Properties

The soil inputs needed in CERES models can be categorized into those that influence:

- water entry and retention in soil,
- water loss by evaporation.
- the limits of water retention capacity, and
- the environment for root growth.

They can be further categorized into single properties needed for the whole soil profile, and those that vary with depth.

Infiltration of water into the soil is calculated as the difference between precipitation and runoff. Runoff is calculated using the USDA-Soil Conservation Service (SCS) procedure known as the curve number technique. The procedure uses total precipitation in a calendar day to estimate runoff.

To determine the runoff curve number for crop land soils, it is necessary to decide which of four hydrologic soil groups best describes the soil. The hydrologic groups include four categories for potential runoff: A = low, B = moderately low, C = moderately high, and D = high. The curve number (CN2) is determined from the slope of the site and the hydrologic category. The curve number is then modified for the degree of conservation practices followed.

Other inputs for the CERES models can be obtained with either field-measured or approximated values. If field testing is conducted, field measurements are essential.

The albedo is the measured fraction of the incoming solar radiation that is reflected back into the atmosphere. Soil albedo can be measured with a specially shielded solarimeter pointed toward the ground. If measurements are not possible, the soil albedo values can be approximated from the color of the upper horizon. These range from about 0.09 for black soils to about 0.18 for light soils.

The stage 1 evaporation constant (U) can be measured with weighing lysimeters,

## The Limits of Soil Water Availability

when the soil is bare and wet. It can also be approximated by measuring the difference between the near-surface soil temperature and air temperature, also when the soil is wet and bare. The difference in soil-air temperature, assuming the soil is not shaded by clouds, will be small during first stage evaporation but will increase rapidly once the first stage ends. The cumulative potential evaporation from the time the soil was thoroughly wetted until the end of first stage is the value U. The value ranges from about 5 mm for coarse-textured soils and some self-mulching clay soils to about 15 mm for clay loams. If soils are poorly drained, U is increased.

The drainage evaluation requires the input soil water content values of drained upper limit (DUL) and saturation (SAT). Field saturation can be measured by providing conditions for water to stand on a plot until the soil water content no longer increases through all soil depths of the root zone. Under these conditions, the best results are obtained from properly calibrated neutron soil water probes. After SAT has been determined, water is no longer added to the soil surface and an impervious cover is placed over the soil to prevent evaporation. Measurements of the soil water content during drainage provide the information needed to calculate a drainage coefficient (SWCON). When the soil water content practically stops draining, the drained upper limit (DUL) is reached.

If measurements of SAT and SWCON are not available, they can be approximated from soil classification information. The value for SAT is assumed to be 85% of total porosity and SWCON can be approximated from the permeability classes available from soil. Values of SWCON can vary from 0.85 for very rapid to 0.01 for very slow permeability.

The DUL values can be measured from the drainage experiment for evaluating the soil drainage coefficient.

The lower limits of moisture content (LOL) are derived from successive measurements of soil water content with depth during a period when a field crop was subjected to severe drought stress. Water content measurements are continued until the plant nearly dies or becomes dormant. Data from adequately fertilized field plots in which plants reach maximum vegetative growth before undergoing severe drought stress are preferred over data from plots inadequately fertilized or subjected to early-season stress. The concept is that roots have an opportunity to extend to the maximum depth possible.

With this method one can determine the maximum depth of soil water extraction, which usually will become the lowest soil depth considered in the soil data base. This definition of LOL biases the near-surface measurements because soil evaporation reduces soil water content below LOL. Also, in deep soils there is practically always an incomplete root water extraction and the water content usually does not reach the LOL value. The depth at which root water extraction is usually incomplete varies in soils from about 1.2 m to 1.5 m.

To estimate the LOL values for these two situations, approximations from other depths where values are known can be used. Otherwise estimates based on soil texture are needed.

Empirical equations have been developed to estimate the limits of water extraction where the limits are unknown. The equations are based on a data base of several hundred field-measured limits as reported by Ratliff et al. (1983). The calculations are based on sand, silt, and clay content, and are modified when values of soil organic matter are above 0.2%, when the coarse fragment above 2 mm is significant, and when the bulk density varies from a "normal" one expected for the soil texture being considered. The estimates of the LOL and DUL with this texture-based procedure are subject to some error, but the difference between DUL and LOL, the PLEXW, is conservative and most important. Many soils have PLEXW values of about 13%, but sands are the principal exceptions, where PLEXW values can be considerably less than 13%.

The root weighting factor (WR) is needed to determine the root distribution for new growth each day. By definition, the depth of soil used as model input is to contain the full-grown root zone of the crop. The WR value is the weighting that each depth of soil will receive relative to the total WR values for depths where root growth is occurring, assuming good aeration and sufficient soil water content. Poor aeration and low soil water information from the crop models modify the WR value. Because root growth is always more dominant near the surface under optimum water content, a value of WR between zero and unity is calculated for each depth increment equation that reduces using an exponential WR with depth.

The value of WR can be modified by a constant factor, based on qualitative descriptions for the presence of roots in the soil, if available. Qualitative descriptions indicating no roots seen, or roots only seen between peds are indicators that WR should be less than calculated by the standard equation.

More details of the procedures for estimating soil survey characterization data into inputs for the CERES models are available from Ritchie and Crum (1989).

## References

**Ratliff, L.F., Ritchie, J.T., and Cassel, D.K. 1983.** Field-measured limits of soil water availability as related to laboratory-measured properties. *Journal of the Soil Science Society of America* 47:770-775.

**Ritchie, J.T., and Crum, J. 1989.** Converting soil survey characterization data into 1BSNAT crop model input. Pages 155-167 *in* Land qualities in space and time (Bouma, J., and Bregt, A.K., eds.). Wageningen, Netherlands: PUDOC (Centre for Agricultural Publishing and Documentation).

# Weather Generator Program

**D.C. Godwin**

To evaluate different cropping and fertilizer strategies in any location, it is desirable to conduct experiments over several years to capture variability due to weather. Long-term records of this type are seldom available, but where they exist, a model can be used to provide a complete picture of crop growth, and variations in responses over

Where long-term weather records are not available, an alternative is to utilize stochastic time-series modeling procedures to generate a sequence of weather records with statistical properties that are indistinguishable from the historical sequences. To produce these sequences, a short run of weather data is used to determine some coefficients describing the data. The coefficients are in turn used to generate a longer sequence of data.

A computer simulation model (WGEN) was developed by Richardson and Wright (1984) to generate daily values for precipitation, maximum temperature, minimum temperature, and solar radiation. The program generates a sequence of daily rainfall data by using four precipitation parameters:

- $P(W/W)$  - the probability of a wet day given the previous day was wet,
- $P(W/D)$  - the probability of a wet day given the previous day was dry,
- the shape coefficient of the gamma distribution, and
- the scale parameter of the gamma distribution.

These parameters depend on the month of the year. The program operates by accessing a random number generator and, based on the value of the random variate,

the previous day's wet or dry status, and the first two coefficients, determines whether this day is wet or dry. If it is wet, a second random variate is used with the third and fourth parameters to determine the amount of rainfall.

Daily maximum and minimum temperatures and solar radiation are determined based on a Fourier series describing the change in their mean values and coefficient of variation throughout the year for each of wet and dry days. The simulated values are thus conditioned on the wet or dry status of the day and are adjusted according to an assumed matrix of serial and cross correlation coefficients. This matrix preserves patterns of temperature persistence and ensures that simulated daily values of temperatures and solar radiation are appropriately correlated. This helps minimize the possibilities of simulating a very hot dry day, but with low solar radiation.

## Reference

**Richardson, C.W., and Wright, D.A. 1984.** WGEN: a model for generating daily weather variables. ARS-8. Washington, D.C., USA: U.S. Department of Agriculture. 83 pp.



## Discussion

In the discussion, clarification for D (drainage from the profile) was sought. It was indicated that the exponential relationship between D and water content is used. The model does not simulate:

- runoff from the surrounding area, which adds to water arriving at the site in question;
- evaporation from rain intercepted by leaves; and
- upward flow from shallow water table and wet layer in the profile.

It was also noted that the model may initially simulate more runoff from Vertisols, even though the actual runoff from these soils may be less because of cracks.

There was a lengthy discussion on the WR concept. Questions were raised about genetic variability, and suggestions were made that WR should be different for different crops. The consensus was that WR needs to be investigated further.

The propriety of using the Priestley and Taylor equation in the soil water balance model to calculate evaporation (ES and EP) was questioned. It was argued that saturation deficit which is neglected in the Priestley and Taylor equation is important. Although it is difficult to get saturation deficit data, attempts should be made to simulate this from other properties.

Other important issues discussed were:

- the model does not take into account the interception of rainwater by the plant canopy; and
- the effect of excess water on rooting depth, which can occur some time during the season, is not incorporated in the model.

During discussion on water balance, there was disagreement on use of open-pan evaporation values. It was stated that a radiation-based potential evapotranspiration (PET) equation is more accurate than open-pan evaporation. Ideally, accurate values available in each region should be used for calculation of PET.

Difficulty in getting root data from field experiments was discussed. It was mentioned that vertical root growth proceeds faster than water depletion in upper layers, but branching is generally dependent on soil water content. Root diameter differs depending on order of branching, and root surface area also differs.

It was emphasized that a model has to be balanced, obviating the need to go into details of some particular property of soil water.

# Valuation of Risks to Crop Production

## Risk Analysis

D.C. Godwin and Upendra Singh

Economic risks are common in crop production and arise due to uncertain weather, outbreaks of insect pests and diseases, and market fluctuations. The decision-making capacity of farmers and resource planners would be greatly enhanced if they had some means of quantifying risk associated with particular strategies. The strategy evaluation tools provided by IBSNAT's Decision Support System for Agrotechnology Transfer (DSSAT) examine the variability in output associated with selected strategies, and identify those strategies which maximize economic returns and minimize risk.

The risk analysis component (RA) can evaluate several strategies simultaneously and provides an interpretative summary for decision makers. The RA routines are coupled with the data bases, crop simulation models, and weather generators in DSSAT. The procedure operates as follows:

The user first selects some strategies of interest, such as various sowing dates, fertilizer rates, or even change of crop. The RA package then accesses the various data bases to obtain the required inputs for runs with the simulation models. If weather data do not exist, the RA package will generate a sequence of daily weather data. For each strategy the simulation models are run with the appropriate inputs over a user-selected number of years. The RA package then assembles all the simulation model outputs, examines the outcomes, their variability and risk associated with each strategy, and provides an interpretative summary to the user.

To illustrate, suppose a sorghum crop was grown at, for example, three rates of nitrogen (0, 40, and 80 kg ha<sup>-1</sup>) applied as urea on a shallow Alfisol at ICRISAT Center with 15 years of generated daily weather data. To evaluate the various strategies, the RA routine sorts the outputs for each strategy into ascending order and then assigns a probability to each outcome based on the number of years of simulation. The probability of any given outcome in a 15-year simulation is 1/15. From the output and probability information, a simplified linear segmented approximation to a cumulative probability density function (CPDF) can be assembled for each strategy (Fig. 1).

Strategies can be evaluated either in yield or monetary terms. In both cases, the means and variances associated with each strategy are presented to the user, as is a plot of the CPDFs. The RA package guides the user through identification of the most appropriate strategy. From CPDFs, the least appropriate strategy based on grain sorghum yield is strategy 1. The most preferred strategy for maximizing yield (furthest to the right) is strategy 3 (80 kg N ha<sup>-1</sup>).

When strategies are to be evaluated in monetary terms, the RA package utilizes the principles of stochastic dominance to identify the most "risk efficient" set of strategies. This form of the analysis is used when there is no clear distinction among strategies from the plotted CPDFs (Fig. 2). In monetary terms, strategy 1 is again the least preferred because the net return (Rs ha<sup>-1</sup>) in all years is lowest. However, neither first order nor second order stochastic dominance analysis can distinguish between strategies 2. and 3. In such cases strategy 2 is chosen by risk preferrers while strategy 3 is selected by decision makers with medium or high aversion to risk. The latter group prefers strategy 3 over strategy 2 despite the lower mean net return (3620 vs. 3750 Rs ha<sup>-1</sup>) because the medium and high risk-averse groups prefer a more stable strategy, that is one with lower standard deviation (1200 vs 1850 Rs ha<sup>-1</sup>).

The risk analysis package can also be used to select strategies which deal with the minimums—to minimize stresses during crop growth, minimize nitrogen losses, etc.

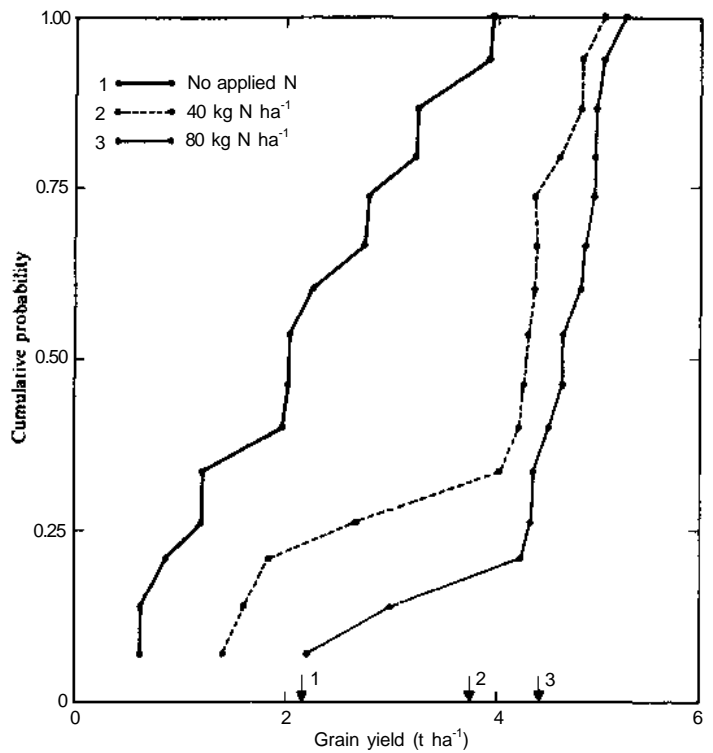

Figure 1. Cumulative probability of sorghum production in a shallow Alfisol at ICRISAT Center, at three rates of applied N, over 15 years (arrows indicate mean for each strategy).

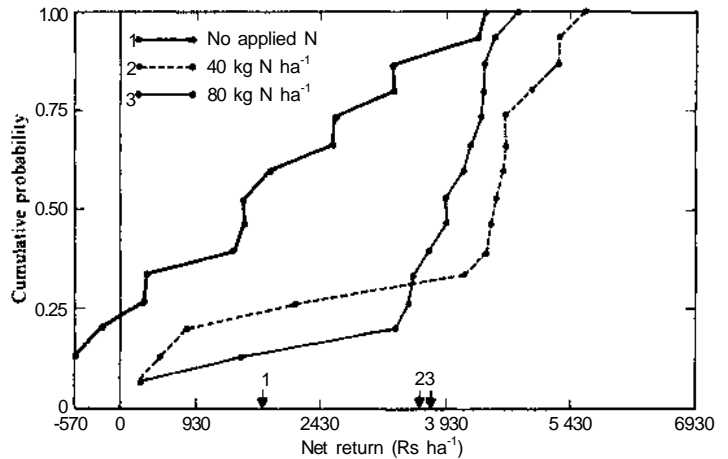

Figure 2. Cumulative probability of obtaining indicated levels of net returns from sorghum production in a shallow Alfisol at ICRISAT Center, at three rates of N application, over 15 years (arrows indicate mean for each strategy).

## Discussion

The presentation was complemented by a case study indicating that the choice of technique was not critical to substantive issues involving risk assessment. Alternative techniques, such as mean-variance analysis, the extended mean Gini, stochastic dominance, stochastic dominance with respect to a function, and the expected utility moment generating function, gave the same ranking of alternative actions. Therefore, there were diminishing returns to increasing sophistication in risk assessment and the present emphasis (in the model) on stochastic dominance was appropriate.

Two suggestions were offered to improve the economic component of the risk assessment routine in the model. First, the output price should be the field price of the crop standing at harvest. If wholesale prices were used, the results would be biased against the lower yielding strategies. Alternatively, the costs of harvesting, threshing, transport, and marketing could be added to the fixed cost entry in the routine. Second, the risk-neutral, profit-maximizing strategy should be included in the last part of the routine which lists the optimal choice for a risk-preferring farmer, a slightly risk-averse farmer, a moderately risk-averse farmer, and a severely risk-averse farmer.

# Physiology of Sorghum and Pearl Millet

## Simulation of Sorghum and Pearl Millet Phenology

J.T. Ritchie and G. Alagarswamy

Genetic variations in the phenology of plants offer a choice of cultivars to fit diverse growing conditions. Dynamic modeling requires predictive functions to simulate the duration of various crop growth stages. Such a general phenology model will be a powerful tool in the breeding of new cultivars to fit the length of growing period.

### Thermal Time Estimation

Temperature affects the rate of several developmental processes. Below a certain minimum temperature, no plant development occurs, and above some optimum temperature, plant development decreases drastically. Between these two defined temperatures, the plant development rate increases linearly with the increase in temperature. Daily progression of plant development can be precisely described by the growing degree day approach.

Several sorghum genotypes in growth chambers were scored for leaf tip appearance as an indicator of the state of plant development at temperatures ranging from 11 to 40°C. Leaf appearance rate was zero at 8°C, which was designated as base temperature (TBASE). Beyond 34°C, leaf tip appearance rates declined drastically. Between these limits leaf tips appeared as a linear function of temperature. These results were used to calculate daily thermal time (DTT) accumulation. When the daily minimum temperature (TEMPMN) is above TBASE and daily maximum temperature (TEMPMX) is below 34°C, DTT in the model is calculated as:

$$DTT = (TEMPMX + TEMPMN) / 2.0 - TBASE \quad (1)$$

Where TEMPMN is less than TBASE, and TEMPMX is greater than 34°C, a different method is followed to calculate DTT. Accumulated thermal time is the sum of daily DTT values. The cumulative DTT is used to determine the duration of various phenological stages and to drive the model through time.

### Organization of Developmental Stages

Phasic development in the CERES-Sorghum model describes the duration of several growth stages. Organization of growth stages strictly follows the dynamic nature in which the plant allocates assimilates to various organs. Growth stages in the model are numerically coded to route the control through the major growth and phenology subroutines of the model. Various plant organs actively grow between stages 1 and 5. Stages 7 through 9 are used to describe events occurring during sowing to seedling emergence. These are important but have a minor effect on phenology. Therefore these are not discussed in detail.

**Stage 1. Seedling emergence to end of juvenile stage.** Plants grow vegetatively and produce leaf primordia during this stage. The rate of development is controlled by temperature. Since plants are not sensitive to photoperiod in this stage, it is important to know when this stage is completed in order to implement photoperiod sensitivity relationships. The genetic differences in the duration of this period are accounted for in the model by a genotype-specific coefficient, P1. The juvenile stage ends when the cumulative DTT equals or exceeds the value of P1.

**Stage 2. End of juvenile stage to end of panicle initiation (PI).** Plants still produce leaf primordia. At the end of this stage, cellular activity in the apical meristem changes from the production of leaf primordia into floral primordia. The rate of development is strictly controlled by favorable photoperiod. Since sorghum plants exhibit quantitative short photoperiod response, daylengths longer than 12 h delay development. Daylength and photoperiod sensitivity of genotypes determine the duration of this stage.

The daylength (HRLT) is calculated as a function of solar declination (DEC in radians), sine and cosine of latitude (LAT) and angle of sun at civil twilight. DEC is a sine function of the day of the year (JDATE). Thermal time from seedling emergence to P1 could be expressed in two photoperiod response ranges, insensitive and sensitive.

In the insensitive range, changes in daylength have no effect on thermal time for PI (DTTPI). There is a threshold photoperiod (P20) above which DTTPI increases linearly with increasing photoperiod. The slope (DTTPI per hour increase in daylength) is termed the photoperiod sensitivity coefficient (P2R). The duration of this stage is dependent upon daylength above P20 and P2R.

**Stage 3. Panicle initiation to end of leaf growth.** The duration of this stage is from PI until flag leaf expansion, and is again temperature dependent. Leaf appearance and expansion is completed during this stage. Stem growth starts in the earlier part of this stage and with time exceeds leaf growth rate. This stage is completed when cumulative DTT equals or exceeds the genetic coefficient P3. The magnitude of P3 was determined from the phenology data reported by Scheaffer (1980). In this study thermal time for flowering (DTTAN) was directly related to DTTPI.

$$DTTAN = 1.199 * DTTPI + 450.0 \quad (2)$$

Since DTTAN is composed of DTTPI and thermal time to reach flowering after PI (DTTPD), equation 2 can also be written as:

$$DTTPI + DTTPD = 1.199 * DTTPI + 450.0 \quad (3)$$

DTTPD could be estimated from equation 3:

$$DTTPD = 0.199 * DTTPI + 450.0 \quad (4)$$

The thermal time from flag leaf expansion until flowering in several sorghum genotypes was estimated to be 150 degree days (Luebbe 1977). After accounting for this from the thermal time value 450.0 in equation 4, thermal time for completing the leaf development (P3) could be estimated by:

$$P3 = 0.199 * DTTPI + 300.0 \quad (5)$$

**Stage 4. End of leaf growth to beginning of grain filling.** During this stage the panicle develops rapidly and the peduncle grows fast, extending the panicle through the flag leaf sheath. Duration of this stage is 270 degree days, and flowering occurs after 150 degree days.

**Stage 5. Effective grain filling to physiological maturity.** Thermal time to complete this stage is determined by the genetic coefficient P5. The panicle accumulates most of the assimilates because grains are growing rapidly. Even though considerable variation for the duration of grain growth exists among genotypes, most of the commonly grown genotypes require about 550 degree days to reach physiological maturity.

**Stage 6. Physiological maturity to harvest.** This stage is reserved for specific users who may want to simulate possible yield reductions arising from the inability to harvest the crop in time.

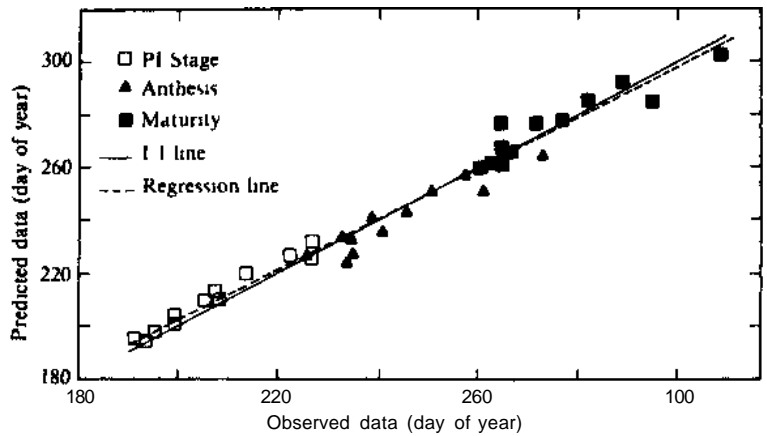

**Figure 1 Comparison of phenology predictions of CFRES Sorghum model with observed data from six locations in India**

### Model Validation

Before the model can be widely used it needs to be adequately tested with independent data sets. The accuracy of predicting phenology is very important since assimilate allocation to different parts of the plant is entirely dependent upon the type of plant organs that grow in any particular growth stage. The phenology predictions were tested using two independent data sets from widely different sorghum-growing regions of India and USA.

Actual and modeled phenological stages for a single hybrid from a range of locations in India are given in Figure 1. The data set was from a multilocal modeling experiment (Huda 1987) in which sorghum hybrid CSH 1 was grown at several locations in India (latitudes 11–31°N). Data presented here indicate that the model is capable of simulating phenological stages reasonably well. The model has also been validated using sorghum data from Texas, USA.

### References

- Huda, A.K.S. 1987** Simulating yields of sorghum and pearl millet in the semi-arid tropics. *Field Crops Research* 15: 309-325.
- Luebke, W.D. 1977** Development events in grain sorghum (*Sorghum buolor* (L.) Moench). Ph.D. thesis, Colorado State University, Fort Collins, Colorado, USA.
- Schaeffer, J.A. 1980** The effect of planting date and environment on the phenology and modeling of grain sorghum *Sorghum buolor* (L.) Moench. Ph.D. thesis, Kansas State University, Manhattan, Kansas, USA.

# Genetic Coefficients for CERES Models

J.T. Ritchie and G. Alagarswamy

Several mechanistic crop simulation models have been used as analytical tools. However, most of these models are site-specific. In order to be truly generic, any model should be able to predict development and growth of any genotype, grown at any location, in any season. To accomplish this, simulation models should contain a set of genetic coefficients that describe how the genotype interacts with its growing environment. The CERES family of crop models contains several genetic coefficients which describe how the development of any genotype is influenced by environmental factors such as minimum and maximum temperatures, and daylength. The numbers and description of genetic coefficients used in CERES sorghum and pearl millet models for simulating phenology are:

- PI Thermal time (above the base temperature 8°C) during which the plants are not responsive to changes in photoperiod. The duration of this period is from seedling emergence to the end of the juvenile period.
- P20 The threshold photoperiod above which the thermal time for panicle initiation (PI) will be influenced by photoperiod.
- P2R Rate at which thermal time for PI increases for every hour increase in photoperiod beyond P20.

## Determination of Genetic Coefficients

Coefficient PI is a genetic coefficient determined in a controlled environment phytotron at Duke University, North Carolina, USA. The temperature was kept constant at 25°C and several sorghum and pearl millet genotypes were grown in two separate phytotrons with photoperiods of 12 h and 15 h. From this experiment coefficient PI was determined as described by Kiniry et al. (1983).

Genetic coefficients related to photoperiod sensitivity determine the extent to which thermal time for panicle initiation (DTTPI) could be delayed when the plants are

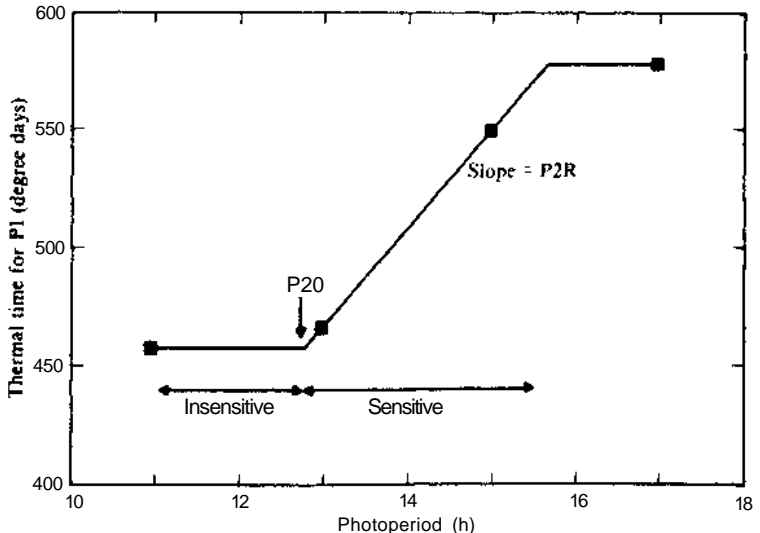

Figure 1. Photoperiod response of sorghum hybrid Wheatland \* ATx 430.



grown in daylengths longer than some optimum level. The response of a genotype could be expressed in two photoperiod response ranges: insensitive and sensitive (Fig. 1). In the insensitive range, changes in daylength have no effect on DTTPI. There is a threshold photoperiod (P20) above which thermal time for PI increases linearly with increasing photoperiod. The slope (DTTPI per hour increase in daylength) is termed photoperiod sensitivity coefficient (P2R). Thermal time for PI is therefore dependent upon daylength above P20 and P2R.

One of the unique features of CERES family models is the emphasis on the duration of this stage as influenced by genetic differences among genotypes. The genotypic response to photoperiod changes ranges from insensitive to highly sensitive. Genetic coefficients for PI, P20, and P2R for some widely different sorghum genotypes are given in Table 1.

**Table 1. Genetic constants used in modeling the phenology of diverse sorghum genotypes.**

Sorghum genotype	Genetic constants		
	PI (degree days)	P20 (h)	P2R (degree days h <sup>-1</sup> )
60 M	337	12.8	290
80 M	337	12.6	262
100 M	291	11.0	127
RTx 430	400	13.0	123
ATx 623	380	13.0	35
ATx 623 x RTx 430	390	13.0	35
RS 610	275	15.5	30
38 M	291	13.0	12

**Reference**

**Kiniry, J.R., Ritchie, J.T., Musser, R.L., Flint, E.P., and Iwig, W.X. 1983.** The photoperiod sensitive interval in maize. *Agronomy Journal* 75:687-690.

## Discussion

Several participants were concerned about the effect of nutrient and drought stresses on crop phenology. The speakers felt that these were of importance only under 'extreme' stress levels. Mild drought stress hastened flowering since the meristem temperature increased, but severe stress levels delayed flowering. At this stage it is not practical to incorporate these in the phenology subroutine. The chairman also pointed out the difficulty of separating individual and combined efforts of nutrients and water on sorghum genotypes.

A participant asked whether it is practical to generate genotype-specific coefficients continuously to predict phenology because newer cultivars are regularly released. It was pointed out that on the basis of a line x tester study, the phenology of the hybrid could be predicted from that of the female parent.

The possibility of drawing inferences on weather-based crop phenological data was questioned. It was generally felt that this was only possible in gross terms. The effect of extreme temperature (low and high) on phenology was discussed. It was felt that the genotype differences were mostly in terms of survival rather than in the rates of development. Genotypes tolerant to cold may not necessarily be able to tolerate extremely high temperatures. Generally it was felt that additional input data such as canopy and soil temperatures, and soil moisture content for improving the precision of phenological predictions would unnecessarily complicate the models.

To a specific query on genotype coefficients of millets, it was stated that experience with 10 pearl millet genotypes was similar to that of sorghum.

On the relative importance of photoperiod before and after panicle initiation, the speakers clarified that photoperiod directly influences phenology only before panicle initiation. Later effects are mere reflections of the additional time needed for expanding leaves for which primordia were laid before panicle initiation.

One question related to the effect of the same mean temperature with varying maximum and minimum values. It was felt that within the linear range of phenological response (8–34°C), the mean value sufficiently reflected the effect of maximum and minimum temperatures. When it was pointed out that genotypic differences in base temperatures for seed germination are substantial, the speaker felt that thermal time for leaf tip appearance is conservative and probably unrelated to that based on germination. On thermosensitivity, the speaker suggested that 'thermosensitivity\*' may be attributed to vernalization requirement and expressed the need for consideration of temperature during floral induction period.

The discussion closed with remarks on the wider application of simple models to predict phenology, and encouraged participants to collect relatively simple data over a wider range of environments to increase the application of the models. Efforts should also be made to relate shoot phenology to root phenology and growth.

# Modeling Sorghum and Pearl Millet

## RESCAP: A Resource Capture Model for Sorghum and Pearl Millet

J.L. Monteith, A.K.S. Huda, and D. Midya

Two processes dominate most contemporary models of crop growth: resource capture and the distribution of metabolites to organs with different functions. In field and laboratory studies which provide information for models, most attention has focused

- the role of photosynthesis as determined by radiation, CO<sub>2</sub>, temperature, leaf water status, etc.; and
- water uptake by roots as determined by the balance between atmospheric "demand" and soil "supply."

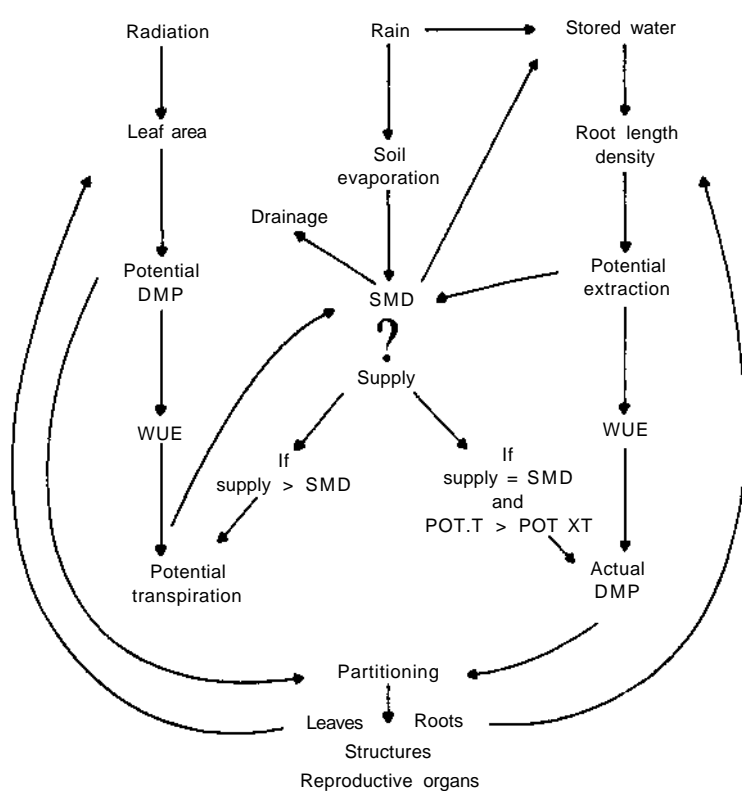

Figure 1. Flow diagram of the RESCAP model.

## Light Interception and Dry Matter Production

Much less attention has been paid to the plant factors that determine water supply—the size of the root system, and the rate at which roots move into new soil.

A new resource capture model, RESCAP, places equal emphasis on the role of leaves in relation to the interception of light, and to the role of roots in relation to the uptake of water (Fig. 1). Two assumptions, which are well supported by field evidence, are central to the model (Monteith, in press):

- the amount of dry matter produced per unit of radiation intercepted by foliage is effectively constant during vegetative growth when water is not limiting; and
- the amount of dry matter produced per unit of water transpired is inversely proportional to mean saturation deficit constant whether water is limiting or not.

Building a model around these conservative quantities keeps the structure simple and is equivalent to the use of constants in physical models, e.g., gravitational acceleration in the relation between the length and period of oscillation of a pendulum.

RESCAP was developed primarily to predict the growth and yield of sorghum and pearl millet, given an appropriate set of environmental variables and genetic coefficients. However, it could readily be adapted to any cereal, and indeed to any seed-producing crop. For sorghum, genetic coefficients are available from measurements at ICRI SAT Center and elsewhere.

At all stages of growth, the rate of dry matter production  $C$  ( $\text{kg m}^{-2} \text{d}^{-1}$ ) per unit of intercepted solar radiation  $S$  ( $\text{MJ m}^{-2} \text{d}^{-1}$ ) is assumed to have a constant value  $e$  provided water is not limiting.

Thus if  $q$  is the mass of dry matter produced per unit mass of water transpired, and  $SD$  is the mean saturation deficit of the atmosphere (kPa), the quantity  $qD = q \times SD$  is conservative for most crops and has a value of about  $9 \text{ g kg}^{-1} \text{ kPa}$  for  $C_4$  cereals (Monteith 1989). The value of  $q$  in  $\text{kg dry matter per kg water}$  is therefore  $9 \times 10^{-3}/SD$ .

On a day when dry matter production is  $C$ , the demand for water to transpire is  $C \cdot SD/(qD)$ . If this quantity is less than the amount of water which the roots can supply (estimation described later), then growth is assumed to be light-limited and has the value:

$$C = f_i e S \quad (1)$$

**where**

$f_i$  is the fraction of radiation intercepted by foliage as estimated by the conventional relation

$$f_i = 1 - \exp(-KL) \quad (2)$$

**where**

$L$  = leaf area index

$K$  = extinction coefficient.

The leaf area index is augmented each day by the increase ( $dL$ ) calculated as the increase in dry weight  $C$  multiplied by the leaf area ratio  $D$ , i.e.,

$$dL = D \cdot C \quad (3)$$

The leaf area ratio ( $\text{m}^2$  leaf per g plant) is calculated as:

$$D = B (1 - x_r - x_{st})$$

**where**

$B$  = specific leaf area ( $\text{m}^2$  leaf per g leaf)

$x_r$  = fraction of dry matter allocated to roots

$x_{st}$  = fraction of dry matter allocated to stems.

$B$  is assumed constant at  $33.0 \text{ m}^2 \text{ kg}^{-1}$  in the current version of the model.

The volume of available water per unit volume of soil AW is assumed to be a function of depth z and the initialization of this quantity is discussed in the next section.

The size and distribution of the root system is specified by two parameters: the downward velocity of a root "front" called THCK (thickness of layer penetrated in one day) and the root length per unit volume RLV (m length per m<sup>3</sup> of soil).

Using a neutron probe we found that the velocity of the root front achieved by sorghum reached a maximum value RRMAX of about 0.035 m d<sup>-1</sup> about 20-30 days after emergence (Monteith 1986). We assumed that the *effective* root front moves down at the same rate, recognizing that roots penetrate below the depth at which the extraction of water can be detected.

Field measurements on sorghum and pearl millet at ICRISAT Center show that RLV usually has a maximum value of 1 to 2 \* 10<sup>4</sup> m m<sup>-3</sup> at minimum root depth (RDMIN) and decreases with depth to about 1/10 of this range at a maximum root depth (RDMAX) at approximately 2 m. We assume that RLV is inversely proportional to the square root of rooting depth RD. Then RLV at depth RD is:

$$RLV(RD) = RLV(I) * (RDMIN/RD)^{0.5} \quad (4)$$

As the allocation of dry matter to the root system is a fraction xr of C then

$$xr * C (TIME) = RHO * RLV * THCK (TIME) \quad (5)$$

**where**

RHO is root weight per unit length (kg m<sup>-1</sup>).

During early growth, we used equation 5 to calculate THCK, setting xr at an arbitrary value of 0.3. When THCK reached its maximum value of RRMAX, we set THCK at RRMAX and allowed xr to decrease with increasing depth.

**Water Capture**

Provided there is no rain or irrigation and evaporation is limited by water extraction and not by water demand, the available water at depth z and time t' is assumed to decrease exponentially with time:

$$AW(z,t') = AW(z,o) * \exp (-t' / TAU) \quad (6)$$

**where**

t' = time when the rooting front arrives at depth z, and

TAU = time constant for the extraction process.

Field measurements on sorghum gave values in the range 20-100 days decreasing with depth. We assume that TAU is inversely proportional to the root length density as suggested by Passioura (1983) so that TAU is proportional to the square root of depth. The rate of extraction at any depth is:

$$- d [AW(z,t')] / dt = [AW(z,o) / TAU] * \exp (-t' / TAU) \quad (7)$$

The depth of the layer traversed by the root zone on the day defined by time t after emergence is THCK so that the amount of water extracted from the layer is:

$$THCK * d [AW(z,t')] / dt' \quad (8)$$

The total potential extraction XT for the whole profile on day t is summed for values of t' from 1 to t (step 1). If XT is less than the water equivalent of dry matter production as estimated from light interception, XT is adopted as the transpiration rate and the rate of dry matter production becomes:

$$C = (qD/D) * XT \quad (9)$$

If the layer of soil above the drying front but below seed depth is wetted by rain or irrigation, we assume that growth and transpiration are light-limited until this water has been removed. The rate of transpiration then reverts to XT if demand exceeds supply. The criterion for the switch from light-limited to water-limited growth is established in the following section.

## Evaporation from Soil Surface

To estimate evaporation from the soil, we used a bucket model and assumed that the depth of the bucket was equal to the depth of sowing. Below this depth, the rate of diffusion to the soil surface was assumed negligible compared with the rate of extraction by the root system.

The rate of evaporation  $E_s$  from newly wet soil with no ground cover was assumed to be 0.9 times the rate of evaporation from a Class A pan, ( $EP$ ). Ground cover reduced the rate by the factor of  $(1 - f_i)$ . Drying reduced the ratio by a factor equal to the amount of water in the surface layer expressed as a fraction of water held at field capacity. If  $AW$  is the actual water content of the layer,  $AD$  is the air-dry value and  $FC$  is the water content at field capacity:

$$E_s = 0.9 * (1 - f_i) * (AW - AD) / (FC - AD) \quad (10)$$

The air-dry water content was assumed to be one-third of the value at 1.5 MPa.

## Soil Water Status

At  $RD_{MAX}$ , taken as 2 m, the maximum available water content ( $MAW$ ) in both the Vertisol and the Alfisol at ICR1S AT Center is assumed to be half the value at 0.1 m. To initiate the distribution of water, the ratio of actual to maximum available water  $ISW$  is assumed to have the same value at all depths. The decrease of available water with depth is:

$$AW = MAW * (1 - 0.5 * RD / RD_{MAX}) * ISW \quad (11)$$

The corresponding initial soil water deficit (mm) is:

$$SMDO = 0.75 * MAW * (1 - ISW) * (RD_{MAX} - RD_{MIN}) * 1000 \quad (12)$$

## Water Budgets

Changes in the soil moisture deficit of the surface layer (0.1 m deep) occur as a result of the direct input of water from precipitation ( $P$ ) or irrigation ( $IRR$ ) and losses as a consequence of evaporation ( $E$ ) or percolation ( $PRC$ ). Suppose  $SM_{10D}$  is the soil water deficit at the beginning of day  $t$ .

If  $(P + IRR) > SM_{10D}$ ,

then  $PRC = P + IRR - SM_{10D}$ , and  $SM_{10D} = 0$ .

But if  $P + IRR \leq SM_{10D}$  then  $PRC = 0$  and  $SM_{10D} = SM_{10D} - (P + IRR)$

Similar algorithms are used if the soil moisture deficit ( $SMD$ ) in the root zone increases as a result of percolation from above ( $PRC$ ) and decreases as a result of transpiration ( $T$ ) and drainage ( $DR$ ). In this case, the loss of water from the bottom of the layer becomes the drainage component  $DR$ .

## Criterion for Water-Limited Growth and Transpiration

A central feature of the model is the comparison each day between the accumulated extractable water  $SXT$  and  $SMD - SMDO$ , which is the net decrease of soil water content since the start of growth. When  $SXT < SMD - SMDO$ , the rate of water uptake by the root system is assumed to be limited by equation 8 which is applied each day throughout the root zone. In this case, the rate of transpiration and of growth are both treated as water-limited. Conversely, if  $SMD - SMDO$  is less than  $SXT$  because of an input of water from rain or irrigation, the difference between  $SXT$  and  $SMD$  is treated as an amount of (free) water which can be supplied by the root system as rapidly as it is demanded by the shoots. This demand is determined by the daily dry matter production and the value for the dry matter water ratio.

## Phenology

The phenological timetable was divided into the usual three stages:  $GS1$  from emergence to panicle initiation,  $GS2$  from panicle initiation to anthesis, and  $GS3$  from anthesis to maturity. The length of each stage is specified in terms of thermal time (units of degree days) above a base of  $7^\circ\text{C}$  and daylength. The daily mean temperature was assumed to be the average of reported maximum ( $T_{max}$ ), and minimum tempera-

tures (1 min), except when T max exceeded 38°C, in which case it was assigned a value of 38°C (Huda 1987). The influence of daylength on development rate is allowed for where appropriate.

#### Allocation of Dry Matter to Shoots

The fraction of above-ground dry matter is divided between leaves (FL), stem (FS), and grain (FG) in proportions which change with plant age.

From emergence to the end of GS2, FL decreases from 0.9 to 0.1 and FS increases from 0.1 to 0.9. During the first 6 days of GS3, both FL and FS decrease to zero and FG increases from zero to unity, remaining at 1 till the end of GS3.

In an alternative procedure for calculating yield, grain number is assumed proportional to the increase of total plant weight in GS2. Weight per grain (W) is then assumed proportional to the length of GS3 and the total dry weight at the end of GS3. In this case, the harvest index is simply proportional to the length of GS3. However, if GW calculated in this way exceeds a limiting maximum value of 0.035 g, it is assigned that value. The effect of this restriction is that harvest index is smaller when vegetative growth is very vigorous.

#### References

**Huda, A.K.S. 1987.** Simulating yields of sorghum and pearl millet in the semi-arid tropics. *Field Crops Research* 15:309-325.

**Monteith, J.L. 1986.** How do crops manipulate water supply and demand? *Philosophical Transactions of the Royal Society A* 316:245-259.

**Monteith, J.L. (In press).** Steps in crop climatology. *In Proceedings of the International Conference on Dryland Farming*. 15-19 Aug 1988, Amarillo, Texas, USA. (Unger, P.W., Jordan, W.R., Sneed, T., and Jensen, R.W., eds.). College Station, Texas, USA: Texas A&M University.

**Passioura, J.B. 1983.** Roots and drought resistance. *Agricultural Water Management* 7:265-280.

## Simulation of Growth and Development in CERES Models

J.T. Ritchie and G. Alagarswamy

Potential productivity of a crop generally depends on conservation of solar energy through photosynthesis when other limiting factors are absent. Only the wavelength bands from 0.4-0.7  $\mu\text{m}$  are useful, a range known as photosynthetically active radiation (PAR). Potential productivity depends on how much of the PAR is intercepted by the crop canopy. Therefore, relating crop growth to PAR interception by the canopy has been more successful than conventional growth analysis. This paper is confined to simulation of growth because developmental aspects have been dealt with earlier in this volume.

#### Leaf Area Development

Accurate prediction of leaf area depends on the ability to predict leaf appearance rate. If temperature records are available, the number of leaves that appear can be calculated using the leaf appearance interval (PHINT). The PHINT values (in degree days per leaf) are 49 for sorghum and 43 for pearl millet.

Since leaves appear only in growth stages 1 to 3, the cumulative number of fully expanded leaves (CUMPH) in sorghum is calculated from the daily thermal time (DTT):

$$\text{CUMPH} = \text{CUMPH} * \text{DTT} / \text{PHINT} \quad (1)$$

Cumulative leaf area of the plant on a given day is then calculated using the Gompertz function:

$$\text{PLAN} = \text{Ae}^{-(K * \text{CUMPH})} \quad (2)$$

where

PLAN = cumulative leaf area

A = maximum leaf area at infinite time

b, K = constants

Individual leaf size of sorghum genotypes differs widely, leading to very different cumulative leaf area. Among narrow- and broader-leaved genotypes the constant K in the Gompertz function varied to a greater extent (25%) compared to the constant b (2%). Hence constant K could be a genotype-specific coefficient.

Leaf expansion growth is sensitive to unfavorable temperatures and soil water deficit. The optimum temperature for maximum leaf expansion for 25 sorghum genotypes ranged between 14 and 32°C in a controlled growth chamber study (Ritchie, J.T. and Alagarswamy, G., unpublished).

## Assimilate Production

The input variable solar radiation (SOLRAD) is first converted into PAR. The relative amount of transmitted light within any crop canopy decreases exponentially as described by the Bouguer-Lambert law. Using this law the amount of light intercepted ( $I/I_0$ ) by the canopy is calculated as:

$$I/I_0 = e^{-K * \text{LAI}} \quad (3)$$

where

K = extinction coefficient

LAI = leaf area index

Thus  $I/I_0$  is generally influenced by K and LAI. In the model, values of K decrease nonlinearly as row spacing increases. Once the amount of PAR intercepted (INTPAR) by the crop canopy is computed, potential daily biomass production (PCARB) is calculated:

$$\text{PCARB} = 4.0 * \text{INTPAR} \quad (4)$$

It is assumed that 4.0 g of total biomass (including roots) are produced for every MJ of PAR intercepted. The expansive and leaky root systems of crops are likely to lose about 35-45% of assimilates partitioned to the roots into the surrounding soil as root exudates. To compensate for such large losses, a higher efficiency of conversion factor is used in the model.

The actual biomass produced is generally well below the potential amount because both biotic and abiotic factors reduce the potential amount. Therefore, in the model potential biomass production is constrained by non-optimal temperature factor (PRFT), nitrogen deficiency factor, and water deficit (SWDF1) factors. Values for these factors range from zero to unity.

In the model the optimum temperature range for photosynthesis was set between 20 and 40°C. When day temperatures deviate from this range, PRFT is used to reduce the rate of photosynthesis.

## Assimilate Allocation

**Stage 1. Leaves and roots constitute the growing organs.** Leaf area growth rate (PLAG) is converted to mass growth rate (GROLF) using specific leaf weight (SLW).



The remainder of the daily assimilate supply (CARBO) is allocated to the root growth (GRORT). If GRORT is less than 25% of CARBO, then GROLF is reduced to 75% of CARBO and the rest is allocated to roots.

**Stage 2. Leaves and roots continue to be the major growing organs.** In some cases the stem also starts to grow and is about 10% of leaf growth. Root growth is never allowed to fall below 25% of CARBO.

**Stage 3. Leaves, stems, and roots are the major growing organs.** Leaf growth is completed now. Leaf weight is derived from PLAG using specific leaf weight. Stem growth increases linearly with DTT. Minimum value for GRORT is set at 30% of CARBO. If GRORT values fall below the minimum value, growth of other organs is reduced to set GRORT at the minimum value. Finally STMWT, LFWT, and PLA values are updated.

**Stage 4. Stem, panicles, and roots are the major growing parts.** Since it is not known when the major portion of panicle growth started, weights of panicle and stem are combined. GROSTM is a linear function of thermal time and influenced by the minimum of two stress factors.

$$\text{GROSTM} = 0.07 * \text{DTT} * \text{AMIN1} (\text{SVVDF2}, \text{TEMF}) \quad (5)$$

The root growth consists of the remainder of CARBO. GRORT is set to a minimum of 20% of CARBO. Leaf senescence due to normal development becomes a major cause of reduction in leaf area. It is calculated as a nonlinear function of DTT.

**Stage 5. Panicles are the major growing organ.** As stated earlier, panicles are grown daily as an integral part of stem weight (STMWT). On the first day in this stage panicle weight (PANWT) is calculated. From then on panicles are grown as independent organs.

$$\text{PANWT} = 0.3 * \text{STMWT} \quad (6)$$

The rate of biomass production during stage 5 is generally lower than in earlier stages. Post-anthesis decline in the efficiency of conversion is accounted for in the model by reducing the calculated value of CARBO.

The sorghum panicle has primary, secondary, and tertiary branches, and grains develop in each branch. This causes an enormous difference in grain size within the panicle. Thus, unlike CERES Wheat and Maize models, growth rate of the whole panicle (GROPAN) is modeled in sorghum rather than individual grains.

The optimum mean temperature for grain growth in sorghum varies from 20 to 25°C. Kernel weight is markedly reduced beyond this range. Hence in modeling panicle growth, a relative panicle filling rate (RGFILL) is calculated first as a function of temperature. RGFILL is proportional to temperature and its value ranges from zero to unity. When TEMPMN is between 20 and 25°C, the value for RGFILL is unity. For TEMPMN values beyond this range, RGFILL is reduced linearly to zero. Panicle size at the time of anthesis influences the rate of its growth during grain filling. Panicle growth constant (PGC) accounts for the influence of panicle size on its rate of growth.

As the panicles approach physiological maturity, their growth rate slows down and is accounted for by a panicle aging factor (PAF). When there is a water deficit, SWDF2 is used to reduce the GROPAN.

$$\text{GROPAN} = \text{RGFILL} * \text{PGC} * \text{PAF} * \text{SWDF2} \quad (7)$$

If all the CARBO is not utilized to support GROPAN, which happens under adequate moisture, the remainder of CARBO is equally partitioned to grow stems and roots. Under severe water deficit, stored materials from the stem are known to support

the panicle growth. In the model when CARBO is less than GROPAN, stored material from stems is translocated to the panicle to support its growth.

Besides normal senescence due to development, adverse conditions also promote leaf senescence. To account for this, three senescence factors caused by water deficit (SLFW), mutual shading (SLFC), and low temperature (SLFT) were computed. Total amount of leaf area senesced due to unfavorable conditions is termed as SENLA. Plant leaf area senesced (PLAS) is calculated using the minimum of these three factors:

$$PLAS = (PLA - SENLA) * [1.0 - \text{MIN}(SLFW, SLFC, SLFT)] \quad (8)$$

Total amount of leaf area senesced is updated. The leaf area on any given day is the difference between leaf area produced (PLA) and leaf area senesced.

Finally, when physiological maturity occurs, grain weight (GRNWT) is calculated using a threshing percentage of 80%.

$$GRNWT = PANWT * 0.80 \quad (9)$$

Single kernel weight (SKERWT) is calculated using grains per plant (GPP). The values of GPP are calculated in the beginning of stage 5 as a linear function of growth rate between PI and flowering. Values for SKERWT are derived from GPP and GRNWT.

## Model Validation

Before the model can be widely used it needs to be adequately validated with independent data sets.

**Grain yield predictions.** Simulated and measured grain yields from three widely different growing regions are given in Figure 1. The observed and predicted values are scattered close to the 1:1 line. Data from Bushland is overestimated in the model due to the inability to correctly model tiller contribution to total grain yield. Poor prediction at Kununurra is from zero nitrogen plots over 2 years which might be due either to severe N deficiency factors in the model, or incorrect initial soil N input values.

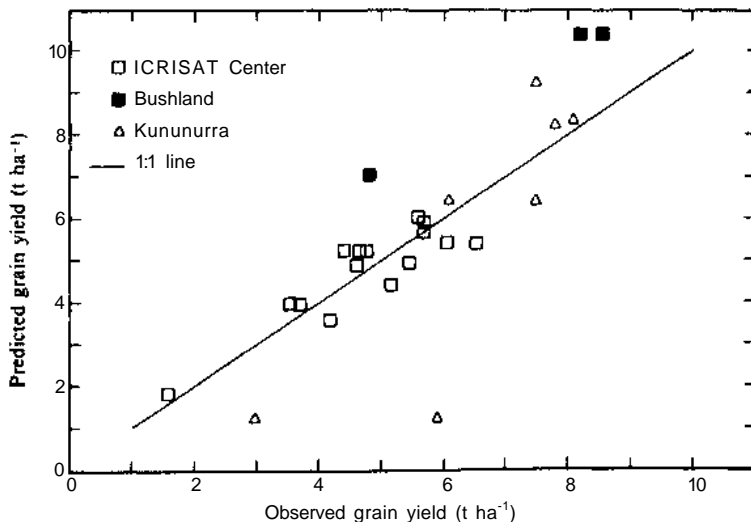

Figure 1. Relation between predicted and observed grain yield of sorghum using the CERES model.

**N Response.** Location specificity of grain yield response to N fertilizer was tested using data from ICRISAT Center (Fig. 2). At ICRISAT Center over the range of 0 to 160 kg N ha<sup>-1</sup>, the model predicted the N response reasonably well. However model predictions in Kununurra where the N level ranged from 0 to 370 kg ha<sup>-1</sup>, were not very good. The model did not simulate N response at lower and higher N levels.

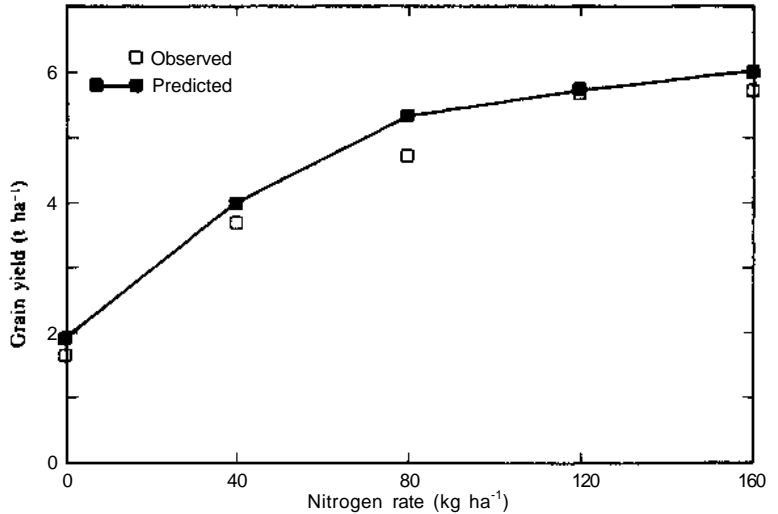

Figure 2. Relation between observed and predicted grain yield of sorghum over a range of N levels.

## Discussion

During the discussion on the RESCAP model it was clarified that the model assumes only three layers of soil: 0-10 cm, 10 cm to root front (maximum depth of descending roots), and below the root front. Root senescence is not considered. The model has no nutrient subroutine at present and is applicable only where nutrients are not limiting. It was mentioned that the lack of fit for sorghum cultivar CSH 6 in the postrainy season could be due to its temperature sensitivity. This could be easily tested by altering the TBASE.

There was some concern expressed as to why the model, which was to predict total biomass more elegantly, poorly predicted biomass compared to grain yields. Some concern was also voiced regarding the use of the same data for model building and model testing. A question on the philosophy of no carbon allocation to roots after anthesis was raised. It was clarified that roots remain functional but do not grow after anthesis. On the question of the simple RESCAP model requiring more weather parameters than the CERES model, it was mentioned that the authors were trying to reduce this requirement, but felt that the saturation deficit parameter was essential. It was also suggested that the model be validated by estimating biomass by growth stages since data for such analyses were available. On the question of whether such models could be used in remote sensing, the authors replied that it could be done with some modifications.

In the discussion following the presentation of simulation of growth and development in CERES models, clarification was sought regarding the calculation of potential leaf area from the number of leaves, leaf size, etc. It was suggested that sink size also determined the rate of senescence after anthesis. It was also mentioned that green leaves do not necessarily constitute functional leaves. Because only the top four or five leaves of sorghum contribute most to photosynthesis, the senescence of lower leaves may not be of consequence. It was clarified that both N and water deficits affected expansion growth. It was pointed out that specific leaf area varied with age. Unlike SORGF, the CERES model is not based on a given leaf number, rather the leaf number is determined by a genetic constant and photoperiod in GS1.

The potential of such a model for the geographical mapping of crop grain yields was raised. The authors replied that it could be achieved if variations were only in N and water. The model does not take into account insect pests, diseases, weeds, phosphorus, and other micronutrients.

Queries on the rationale of a single TBASE were raised. It was pointed out that unlike the TBASE based on germination and emergence, the model uses TBASE and TMAX based on leaf tip appearance. When both SWDF1 and SWDF2 were operating, the law of minimum was applied. It was clarified that when nitrogen was limiting, leaf expansion was affected, but photosynthesis was not affected. The model should look into the compensatory mechanisms operating. It was felt that the tillering routine needed improvement. Indian sorghums have been bred against tillering, and tillering was noticed when temperatures fell below 10°C.

# Conclusion

## Models, Software, and Documentation

J.T. Ritchie, J.L. Monteith, D.C. Godwin, and A.K.S. Huda

### Models

The crop models described and discussed were primarily the CERES models series 2.00 and the RESCAP model, both of which concentrated on sorghum, and to a lesser extent on pearl millet. Functional models adopted by the IBSNAT project presently include those on maize, wheat, and soybean, and when sufficiently validated will include sorghum, pearl millet, groundnut, potato, barley, and field bean. Revisions in the CERES models are incorporated every 18 months.

Some important areas for future improvement of the models are:

- more detailed treatment of root growth;
- better understanding of runoff and infiltration;
- tillage aspects and their effect on root environment, water storage in the surface layer, N-dynamics through residue incorporation;
- incorporation of information on ammonia loss;
- simulation of phosphorus dynamics;
- study of rotational effects and legumes in the system; and
- evaporation process and ET aspects.

### Software and Documentation

Although the present version of the DSSAT package is preliminary, it was possible to provide diskettes and documentation. In fact, a majority of the participants received available software and documentation. IFDC plans to make available versions of the CERES models with a user manual. A list of documents distributed during the workshop is provided in the Appendix below. Texas A&M University, USA, has published a book on CERES-Maize, (Jones and Kiniry 1986) which comes with two diskettes. A similar book on CERES-Wheat is likely to be available in mid-1989, followed by one on CERES-Sorghum in 1990.

### Reference

**Jones, C.A., and Kiniry, J.R. 1986.** CERES-Maize: A simulation model of maize growth and development. College Station, TX, USA: Texas A&M University Press. 194 pp.

The documentation listed below is available either from the authors or concerned institutions.

### Additional Documentation

**Alagarswamy, G., Ritchie, J., Godwin, D.C, and Singh, U. 1989.** A user's guide to CERES-Sorghum, Version 2.00. Honolulu, HI, USA: IBSNAT.

**IBSNAT (International Benchmark Sites Network for Agrotechnology Transfer). 1988.** Data base management system, experiment data entry draft user's guide, Version 2.1. Honolulu, HI, USA: IBSNAT.

**IBSNAT (International Benchmark Sites Network for Agrotechnology Transfer). 1988.** Experimental design and data collection procedures for IBSNAT-the minimum data set for systems analysis and crop simulation. 3rd edn. Technical Report 1. Honolulu, HI, USA: IBSNAT. 74 pp.

**IBSNAT (International Benchmark Sites Network for Agrotechnology Transfer). 1988.** Data base management system, MDS retrieval for crop models, draft user's guide, Version 2.1. Honolulu, HI, USA: IBSNAT.

**IBSNAT (International Benchmark Sites Network for Agrotechnology Transfer). 1988.** Data base management system, weather entry data, draft user's guide, Version 2.1. Honolulu, HI, USA: IBSNAT.

**Ritchie, J.T., and Crum, J. 1988.** Converting soil survey characterization data into IBSNAT crop model input. Honolulu, HI, USA: IBSNAT

**Monteith, J.L., Huda, A.K.S., and Midya, D. 1988.** RESCAP: a general crop model based on process of resource capture, (unpublished.)

# Participants

M.R. Chaudhary  
Senior Soil Physicist  
Department of Soils  
Punjab Agricultural University  
Ludhiana 141 004  
India

Renu K. Chopra  
Plant Physiologist  
Water Technology Centre  
Indian Agricultural Research Institute  
New Delhi 110 012  
India

R.G. Dumsday  
Senior Lecturer  
School of Agriculture  
La Trobe University  
Bundoora, Victoria 3083  
Australia

H. Eswaran  
Program Leader  
Soil Management Support Services  
U.S. Department of Agriculture  
P.O. Box 2890  
Washington, D.C. 20013  
USA

D.C. Godwin  
Agronomist and Systems Modeler  
International Fertilizer Development Center  
P.O. Box 2040  
Muscle Shoals, AL 35662  
USA

S.S. Hundal  
Agrometeorologist  
All India Coordinated Research Project  
on Agrometeorology  
Department of Agricultural Meteorology  
Punjab Agricultural University  
Ludhiana 141 004  
India

T.N. Ashok Kumar  
Assistant Agronomist  
All India Coordinated Research Project  
for Dryland Agriculture  
GKVK Campus  
Bangalore 560 065  
India

A.N. Mehta  
Professor and Head  
Department of Agricultural Meteorology  
B.A. College of Agriculture  
Gujarat Agricultural University  
Anand 388 110  
India

Abdi Ahmed Mohammed  
USAID-Wyoming Team  
Bay Region Agricultural Development Project  
Bonka Research Station  
P.O. Box 2971  
Mogadishu  
Somalia

R.S. Narang  
Professor and Head  
Department of Agronomy  
Punjab Agricultural University  
Ludhiana 141 004  
India

B.S. Rana  
Project Coordinator (Sorghum)  
National Research Centre for Sorghum  
Rajendranagar  
Hyderabad 500 030  
India

J.T. Ritchie  
Homer Nowlin Chair  
Department of Crops and Soils  
Plant and Soil Science Building  
Michigan State University  
East Lansing, MI 48824-1222  
USA

G.S. Saroa  
Assistant Soil Chemist  
Dryland Research Project  
Punjab Agricultural University  
Garshankar  
Hoshiarpur 144 527  
India

U. Schulthess  
Agronomist  
International Livestock Centre for Africa  
P.O. Box 5689  
Addis Ababa  
Ethiopia

Phool Singh  
Crop Physiologist  
College of Agriculture  
Haryana Agricultural University  
Hisar 125 004  
India

S.P. Singh  
Project Coordinator  
Central Research Institute for  
Dryland Agriculture  
Santoshnagar, P.O. Saidabad  
Hyderabad 500 659  
India

Upendra Singh  
Soil Scientist and Systems Modeler  
International Fertilizer Development Center  
P.O. Box 2040  
Muscle Shoals, AL 35662  
USA

S.K. Sinha  
Professor of Eminence  
Water Technology Centre  
Indian Agricultural Research Institute  
New Delhi 110 012  
India

Chirtchart Smitobol  
Head, Soil and Water Management  
Farming Systems Research Institute  
Department of Agriculture  
Bangkhen  
Bangkok  
Thailand

H.L.S. Tandon  
Director  
Fertiliser Development and Consultation  
Organization  
C-110, Greater Kailash 1  
New Delhi 110 048  
India

M.C. Varshneya  
Professor-in-Charge  
Centre for Advanced Studies in  
Agricultural Meteorology  
College of Agriculture  
Pune411 005  
India

## ICRISAT

M. Goon  
Assistant Director General (Administration)  
B.C.G. Gunasekera  
Advisor to the Director General for Donor Relations  
J.S. Kanwar  
Deputy Director General (Emeritus)  
J.L. Monteith  
Director, Resource Management Program (RMP)  
Y.L. Nene  
Director, Legumes Program  
K.B. Srinivasan  
Assistant Director General (Liaison)  
J.M.J. de Wet  
Director, Cereals Program  
G. Alagarswamy  
Plant Physiologist II, Cereals  
F.R. Bidinger  
Principal Plant Physiologist, Cereals  
J.R. Burford  
Principal Soil Chemist, RMP  
D.R. Butler  
Principal Microclimatologist, RMP  
J.W. Estes  
Computer Services Officer  
L. Flynn  
Senior Documentation Assistant, Computer Services  
S.D. Hall  
Acting Head, Information Services  
A.K.S. Huda  
Agroclimatologist II, RMP  
K.B. Laryea  
Principal Soil Physicist, RMP  
K.K. Lee  
Principal Cereals Microbiologist, RMP  
V. Mahalakshmi  
Plant Physiologist II, Cereals  
C.K. Ong  
Principal Agronomist (Cropping Systems), RMP  
D.L. Oswalt  
Program Leader, Training  
J.M. Peacock  
Principal Plant Physiologist, Cereals  
T.J. Rego  
Soil Scientist II, RMP  
K.L. Sahrawat  
Sr. Soil Scientist II, RMP  
N. Seetharama  
Sr. Plant Physiologist II, Cereals  
A.M. Shekh  
Research Fellow, RMP

Piara Singh  
Soil Scientist II, RMP  
R.P. Singh  
Economist II, RMP  
Sardar Singh  
Soil Scientist II, RMP  
G.D. Smith  
Principal Soil Scientist, RMP  
D.P. Verma  
Soil Scientist/Chemist, RMP  
S.M. Virmani  
Principal Agroclimatologist, RMP  
T.S. Walker  
Principal Economist, RMP  
S.P. Wani  
Microbiologist II, RMP



# **Glossaries**

## CERES Glossary

A	maximum leaf area at infinite time	NUF	N uptake factor
AM1N1	Fortran library function to select the minimum	NUF NUP P	amount of upward water flow amount of water from precipitation
ANDEM	crop N demand		
CARBO	daily assimilate supply	PANWT	panicle weight
CNRF	carbon to nitrogen ratio factor	PAR	photosynthetically active radiation
CUMPH	cumulative number of fully expanded leaves	PCARB	potential daily biomass production
		PI	panicle initiation
CW	total water-extractable carbon in the soil layer ( $M C g^{-1}$ soil)	PHINT	leaf appearance interval
DEC	solar declination (radians)	PLA	leaf area produced
DEPTH	thickness of the soil layer being considered	PLAG	leaf area growth rate
		PLAN	cumulative leaf area
DLAYR(L)	depth of a soil layer L (cm)	PLAS	plant leaf area senesced
DMINR	potential decay rate	PLEXW	difference between DUL and LOL
DMOD	zero to unity factor for adjusting mineralization rate on unusual soils	PR FT	temperature factor
DNRATE	denitrification rate	PI	thermal time during which plants are not responsive to changes in photoperiod
DRAIN	drainage rate	P20	threshold photoperiod above which DTTP1 increases linearly with increasing photoperiod
DTT	daily thermal time		
DTTAN	thermal time for flowering	P2R	rate at which thermal time for PI increases for every hour increase in photoperiod beyond P20
DTTPI	thermal time for panicle initiation		
DTTPD	thermal time to reach flowering after PI		
DUL	drained upper limit	R	runoff
EP	evaporation from plants	RANC	N which is immobilized into the microbial biomass during the decay process
ES	evaporation from soil		
ET	evapotranspiration	RCNP	critical N concentration in roots
FLOW(L)	rate of upward flow of water in layer L	RDECR(JP)	decay rate of organic matter of pool JP
FLUX(L)	volume of water moving from a layer L to the layer below	RGFILL	panicle filling rate
FOM	fresh organic matter	RHMIN	N released from decaying humus
FON	fresh organic nitrogen	RNDEM	root N demand
FPOOL(L,JP)	pool of either carbohydrate (JP = 1), cellulose (JP = 2), or lignin (JP = 3) ( $Mg ha^{-1}$ ) in layer L	RTWT	root biomass
FT	temperature factor effect on denitrification	S	saturated volumetric water content
		SAT	water content at saturation
FW	zero to unity water soil water factor effect on denitrification	SENLA	total leaf area senesced due to unfavorable conditions
GPP	grains per plant	SKERWT	single kernel weight
GRCOM	amount of organic matter decaying	SLFC	senescence factor caused by mutual shading
GRNOM	gross mineralization of N associated with decay of organic matter	SLFT	senescence factor caused by low temperature
GRNWT	grain weight	SLFW	senescence factor caused by water deficit
GROLF	mass growth rate	SLW	specific leaf weight
GROPAN	growth rate of the whole panicle	SNH4	ammonium pool
GRORT	root growth	SN03(L)	quantity of nitrate present in layer L
GROSTM	stem growth		
GI	proportion of organic matter pool which decays in one day	SOLRAD	solar radiation
HRLT	day length	ST	soil temperature
I	amount of water from irrigation	STMWT	stem weight
INTPAR	amount of PAR intercepted by the crop canopy	SWCON	drainage coefficient
		SWDFI	soil water deficiency factor
I/I <sub>0</sub>	amount of light intercepted by the canopy	SW(L)	volume of water present in a layer L
JDATE	day of the year	TANC	actual N concentration in aerial plant parts
JP	organic matter pool which is decaying	TBASE	base temperature
LAI	leaf area index	TEMPMN	daily minimum temperature
LAT	latitude	TEMPMX	daily maximum temperature
LFWT	leaf weight	TCNP	critical N concentration in aerial plant tissue
LOL	lower limit of moisture content	TF	temperature factor
MF	moisture factor	TMNC	TANC at its minimum value
NFAC	N factor (zero to slightly above unity)	TNDEM	plant tops N demand ( $kg N ha^{-1}$ )
NHUM(L)	N contained within the humus layer L	TOPWT	weight of aerial plant parts ( $kg ha^{-1}$ )
NNOM	N released from all organic sources	TOTN	soil extractable mineral N
NOUT	nitrate lost from a layer L ( $kg N ha^{-1}$ )	TRNU	potential N uptake from the whole profile
N03(L)	nitrate concentration in layer L ( $M N g^{-1}$ soil)	WR	root weighting factor

## RESCAP Glossary

AD	moisture content of air-dry soil ( $m^3 m^{-3}$ )
AW	available water per unit volume of soil
B	specific leaf area ( $m^2$ leaf per g leaf)
C	rate of dry matter production ( $kg m^2 d^{-1}$ )
D	leaf area ratio ( $cm^2 g^{-1}$ )
DR	drainage (mm)
E	evaporation ( $mm d^{-1}$ )
e	rate of dry matter production per unit of intercepted solar radiation ( $kg MJ^{-1}$ )
EP	evaporation rate from Class A pan ( $mm d^{-1}$ )
Es	soil evaporation rate ( $mm d^{-1}$ )
F <sub>1</sub>	fraction of radiation intercepted by foliage
FC	water content at field capacity ( $m^3 m^{-3}$ )
FG	fraction of above ground dry matter allocated to grain
FL	fraction of above ground dry matter allocated to leaves
FS	fraction of above ground dry matter allocated to stems
GSI	thermal time from emergence to panicle initiation ( $^{\circ}C d$ )
GS2	thermal time from panicle initiation to anthesis ( $^{\circ}C d$ )
GS3	thermal time from anthesis to maturity ( $^{\circ}C d$ )
IRR	irrigation (mm)
ISW	ratio of actual to maximum available water
K	extinction coefficient
L	leaf area index ( $m^2 m^{-2}$ )
MAW	maximum available water content ( $m^3 m^{-3}$ )
P	precipitation ( $mm d^{-1}$ )
PRC	percolation (mm)
q	mass of dry matter produced per unit mass of water transpired ( $kg kg^{-1}$ )
qD	dry matter normalized transpiration ratio ( $kg kg^{-1} kPa$ )
RD	rooting depth (m)
RDMAX	maximum root depth (m)
RDMIN	minimum root depth (m)
RHO	root weight per unit length ( $kg m^{-1}$ )
RLV	root length per unit volume of soil ( $m m^3$ )
RRMAX	maximum value of THCK ( $m d^{-1}$ )
S	solar radiation ( $MJ m^2 d^{-1}$ )
SD	mean saturation deficit (kPa)
SMD	soil moisture deficit (mm)
SMDO	initial soil water deficit (mm)
SM 10D	soil moisture at beginning of day t (mm)
SXT	accumulated extractable water (mm)
T	transpiration ( $mm d^{-1}$ )
t'	arrival of root front at given depth
TAU	time constant for extraction process (d)
THCK	thickness of layer penetrated in one day (m)
Tmax	maximum temperature ( $^{\circ}C$ )
Tmin	minimum temperature ( $^{\circ}C$ )
W	weight per grain (g)
xr	fraction of dry matter allocated to roots
XT	potential extraction of soil water ( $mm d^{-1}$ )
xst	fraction of dry matter allocated to stems
z	depth of soil profile (m)

**RA-00163**



**ICRISAT**

**International Crops Research Institute for the Semi-Arid Tropics  
Patancheru, Andhra Pradesh 502 324, India**