



MPIfG Discussion Paper 06/5

**One Path or Several?**

Understanding the Varied Development of Tripartism  
in New European Capitalisms

Sabina Avdagic



Sabina Avdagic

**One Path or Several?**

**Understanding the Varied Development of Tripartism in New European Capitalisms**

MPIfG Discussion Paper 06/5

Max-Planck-Institut für Gesellschaftsforschung Köln

Max Planck Institute for the Study of Societies Cologne

September 2006

---

© 2006 by the author(s)

MPIfG Discussion Paper | ISSN 0944-2073

MPIfG Discussion Papers are refereed scholarly papers of the kind that are publishable in a peer-reviewed disciplinary journal. Their objective is to contribute to the cumulative improvement of theoretical knowledge. The papers can be ordered from the institute for a small fee (hard copies) or downloaded free of charge (PDF).

**Downloads**

[www.mpifg.de](http://www.mpifg.de)

Go to *Publications / Discussion Papers*

Max-Planck-Institut für Gesellschaftsforschung

Max Planck Institute for the Study of Societies

Paulstr. 3 | 50676 Cologne | Germany

Tel. +49 221 2767-0

Fax +49 221 2767-555

[www.mpifg.de](http://www.mpifg.de)

[info@mpifg.de](mailto:info@mpifg.de)

## **Abstract**

Are newly established institutions capable of shaping actors' strategies and coordinating behavior on a single path? Contrary to punctuated equilibrium analyses, this paper suggests that the constraining capacity of a range of newly established institutions in new European capitalisms is weak and that their very interpretation is subject to contention. Focusing on peak-level tripartism – a formally similar institution whose functioning has varied across national contexts – this paper proposes an actor-centered framework to elucidate the logic and consequences of actors' ongoing strategic maneuvering for the interpretation, enactment, and development of these young institutions. Combining insights of rational choice and historical institutionalism, the paper develops a heuristic model which, by focusing on strategic choices of government officials and union leaders, links the varied enactment of tripartism to different power balances that become mutually accepted in the course of their repeated interactions. In offering a set of falsifiable propositions, the paper provides a guideline for building analytical narratives to evaluate empirically this model.

## **Zusammenfassung**

Sind neu geschaffene Institutionen in der Lage, Akteurstrategien zu determinieren? Der Ansatz dieses Discussion Papers steht im Gegensatz zu „Punctuated-Equilibrium“-Ansätzen. Es wird argumentiert, dass in den neuen osteuropäischen Marktwirtschaften der Einfluss einiger neu geschaffener Institutionen schwach und ihre Interpretation strittig ist. Im Fokus der Betrachtung steht dabei der Tripartismus auf zentraler Ebene – eine Institution, die in verschiedenen nationalen Kontexten unterschiedliche Funktionen entwickelt hat. Von einem akteurzentrierten Ansatz aus werden Logik und Konsequenzen des permanenten strategischen Manövrierens der Akteure für die Interpretation, Inkraftsetzung und Entwicklung dieser jungen Institutionen untersucht. Das Paper kombiniert Erkenntnisse des „Rational-Choice“-Institutionalismus und des historischen Institutionalismus und entwickelt daraus ein heuristisches Modell, das – durch Fokussierung auf die strategischen Entscheidungen von Regierungsbeamten und Gewerkschaftsführern – die unterschiedlichen Inkraftsetzungen des Tripartismus mit unterschiedlichen Kräfteverhältnissen in Verbindung setzt. Diese wiederum werden im Zuge ihrer wiederholten Interaktionen gegenseitig anerkannt. Das Paper stellt eine Reihe falsifizierbarer Hypothesen auf, die Anhaltspunkte für „Analytical Narratives“ bieten, anhand derer das Modell empirisch bewertet werden kann.

**Contents**

Introduction	5
Postcommunist tripartism: Extensive functions, ambiguous rules	7
Causes or effects? Reconsidering the institutions–behavior link	9
The four pillars of an interactionist approach	12
Shaping postcommunist tripartism: Modeling interactions	17
Initial choices	17
Subsequent choices	21
Interaction outcomes: Distinct institutional paths	23
A guideline for applying the model	27
Conclusions: Power, perceptions and institutional development	28
References	31

## Introduction

One of the largest institution-building projects in history took place in a surprisingly short period of time. The early 1990s witnessed the wholesale replacement, or at the very least a thorough adaptation, of economic and political institutions across post-communist Europe. As a result, scholarly attention has focused on explaining particular institutional choices that individual countries made following the collapse of communism. Given the magnitude of institutional transformation and the short time in which the main pillars of the new system were constructed, it is not surprising that much of this research has been dominated by analyses inspired by the punctuated equilibrium model of institutional change (Gould 1982). Featuring the idea of temporal path dependence (see Collier/Collier 1991; Krasner 1988; Mahoney 2000), such analyses commonly distinguish between two periods with an alternating influence of agency and structure. Actors' choices are thought to be particularly important during the period of critical junctures, such as those of extraordinary politics that characterize the onset of regime transitions. But once the choices about formal institutions are made, the importance of agency seems to diminish as behavior is expected to become increasingly governed by constraints and incentives provided by new institutions.

In focusing on choices made during the critical juncture, this type of analysis has therefore largely neglected a number of important questions related to the subsequent development of these newly established institutions: What happens to new institutions once the initial period of extraordinary politics and “mega-change” is over? Are they capable of shaping actors' strategies and policy choices or, alternatively, is their constraining capacity weak and their very interpretation subject to further contention? If the latter is the case, what determines the size of the gap between formal institutional rules and their interpretation and enactment in practice? In short, what mechanisms drive the development of young institutions in systems undergoing uncertain change?

These questions are particularly pertinent to a range of regulative political-economic institutions whose degree of self-reinforcement is unlikely to be as strong as that of constitutive rules and, in particular, of formal political institutions.<sup>1</sup> Given the novelty of many regulative institutional arrangements, and often the simultaneous absence of significant penalties for non-compliance with their rules, the outcomes of such institutions cannot be simply read off their formal parameters. Indeed, as ample examples from these new capitalisms demonstrate, the functioning of various regulatory institutions has often differed considerably from their formal requirements. This has been particularly clear in the sphere of industrial relations, where the functioning of largely

---

This paper draws on Chapter 2 of my book manuscript entitled “Power Perceptions and Institutional Development: Government–Union Interactions in Post-Communism.” I am grateful to Colin Crouch, Wolfgang Streeck, Patrik Aspers and Cornelia Woll for constructive criticism and valuable suggestions.

1 On the distinction between regulative and constitutive institutions, see Searle (1995) and Alexander (2004).

similar peak-level tripartite arrangements for centralized bargaining and policy consultation has varied considerably across countries. In some cases, these corporatist-type structures have assumed an important role in policymaking and generated comprehensive agreements facilitating economic adjustment and spanning multiple policy areas. In other cases, however, these formal structures have remained at the margins of policymaking, failing to influence significantly both the shape of broader economic reforms and more specific industrial relations issues.

This evident gap between, on the one hand, formally similar institutional arrangements and, on the other, their enactment across countries has two broader implications. First, it cautions against a superficial categorization of these political economies according to their formal institutional architecture and calls instead for discerning the dynamics of the post-design development of newly established institutions. For it is the way in which these institutions are practiced, rather than their formal parameters, that reveals more about the types of these new capitalisms. Second – and central to this paper – this gap also indicates that the capacity of newly established institutions to constrain behavior and generate credible commitments to particular outcomes might not be sufficiently strong. This, in turn, suggests that our analysis of institutional development in these new capitalisms needs to rest on conceptual pillars that allow for a more extensive role of agency in the post-design period than traditional punctuated equilibrium analysis does.

This paper goes one step in this direction. It suggests the basic pillars of an interactionist approach to institutional development in post-communism and then uses its logic to illuminate the process of development of peak-level tripartism, an institution traditionally associated with a corporatist style of policymaking. I argue, however, that the formal establishment of the new institutions across postcommunist Europe did not determine a definite path of political processes, as rigid punctuated equilibrium arguments would have it. Rather, it opened a set of possible paths or patterns of interaction, the choice of which ultimately depended on actors' ongoing perceptions of their relative power. This allowed similar formal requirements of these institutions to be interpreted and enacted differently, thus generating rather different outcomes across countries and over time.

Instead of demonstrating this argument empirically, this paper engages in a theory-building exercise by suggesting a way of how to study and meaningfully compare the interactive processes that shape these new institutions of economic governance. To this end, I propose a heuristic model that specifies the sources of perceptions of the relative power of the main actors, their impact on the choice of strategies, and the conditions under which the perceptions and thus the strategies will be altered. In distinguishing between union-favorable and union-adverse strategies of the government, and unions' support or opposition to government reforms, I identify a range of institutional paths that can be shaped through a different sequencing of their strategic interplay. Reflecting different degrees of power asymmetries that become mutually accepted in the course

of a repeated play, the resulting paths determine whether these corporatist-type structures become an essential part of policymaking or largely empty shells whose practical purpose is the mere dissemination of information, rather than genuine bargaining and policy deliberation.

The strategic model proposed in this paper emphasizes a common objective of government officials and union leaders to maintain their power while pursuing their specific institutional and policy preferences. This emphasis serves two purposes. First, it allows us to derive a set of falsifiable propositions about actors' strategies. In this way, the model lends itself to an explicit test that can be conducted by building analytical narratives. Second, by differentiating between actors' shared core objectives and their specific, contextually and historically defined institutional and policy preferences, this model illustrates how insights of rational choice and historical institutionalism can be fruitfully combined to explain actors' strategies and thus the varied development and functioning of formally similar corporatist-type institutions.

The paper is organized as follows. Section two offers a brief description of the formal functions and rules of postcommunist tripartism. Section three provides a critical review of accounts that examine the development of this institution by relying on the logic of punctuated equilibrium analysis. Section four sketches the main pillars of the interactionist approach to institutional development, thus providing a basis for the model of government–union interactions presented in the subsequent section. Section six provides a guideline for empirical evaluation of the model. Section seven concludes by recapitulating the argument and contrasting it with standard analyses that explain institutional outcomes in terms of the distribution of power.

### **Postcommunist tripartism: Extensive functions, ambiguous rules**

Peak-level tripartite institutions were established in most countries of Central and Eastern Europe (CEE) at the very onset of democratic and market transitions. Driven not only by the concern to preserve social peace during market transformations, but also by direct and indirect incentives provided by international organizations such as the International Labor Organization and the European Commission, by the mid-1990s such forums had mushroomed across all postcommunist countries. Given the general weakness of organized interests, the absence of collective bargaining arrangements at the sectoral level and of strong works councils at the enterprise level, these national-level corporatist-type forums were soon to become the central industrial relations institutions in these new capitalisms. This form of social partnership was intended to promote coordination between, primarily, representatives of government and organized labor,

but also the slowly emerging employers' organizations.<sup>2</sup> In so doing, these institutions were to prevent conflict and smoothen the process of comprehensive market transformation.

In formal terms, tripartism displays rather similar features across these new capitalisms. In all of them this form of coordination has been formally institutionalized and peak-level tripartite bodies have a legal foundation. Judging by the statutes and laws governing these institutions, they have extensive formal functions. Their task is to facilitate peak-level negotiation and/or deliberation over wages, labor legislation, the terms of industrial restructuring, reforms to the social protection system, and more general economic and social policy. The latter includes issues ranging from the state budget to reform of the tax, pensions and health system. In general, the government is required to present all relevant legislative and policy proposals to discussion in the tripartite council prior to submitting them to parliament.<sup>3</sup>

In theory, such institutions have the potential to generate mutually beneficial policy solutions, ensure efficient and equitable reforms, make incumbents more accountable, and turn labor unions into key stakeholders in the transformation process. In this sense, these formal institutions resemble what students of cooperation have labeled "constructed focal points," denoting formal institutions that specify the rules of the game tailored to capture the gains of cooperation (Garrett/Weingast 1993). Commonly, such "constructed focal points" are thought to be particularly useful in cases where actors have divergent preferences regarding outcomes, such as the content and pace of market transformation.

Below, however, I contend that the potential of postcommunist tripartism to ensure such outcomes is problematic because its rules are neither internalized by actors nor sufficiently precise to stipulate how the latter should behave in specific circumstances. This ambiguity, in turn, creates the possibility that non-adherence to even the most general rules of deliberation may go unpunished. The upshot of this, I argue, is that this regulative institution by itself is unlikely to generate the kind of behavior that would ensure coordination on a stable and mutually beneficial path of cooperation. Lacking such capacity, this institution becomes open to interpretation and thus to different uses by actors trying to advance their particular objectives. The next section elaborates this

---

2 In reality, postcommunist tripartism has been more of a bipartite affair between government and trade unions, at least up to the end of the 1990s. Notwithstanding dramatic decreases in union membership in all CEE countries, it is employers' organizations that appeared to be the weakest and least organized partners in these institutions. Whereas initially this state of affairs reflected the communist legacy of predominant state ownership, later on the situation mirrored the general lack of interest of a large portion of private employers in joining business organizations or entering into bargaining above the enterprise level.

3 There is by now an extensive literature on postcommunist tripartism. For general overviews of the functions of this institution, see for instance Casale (1999a), EIRO (2004a), Iankova (1998; 2002), Kohl/Platzer (2004).



argument in more detail by juxtaposing it with accounts of postcommunist tripartism which assume the potential of its rules to generate the expected behavior.

### **Causes or effects? Reconsidering the institutions–behavior link**

Some of the most prominent accounts of institutional choices in post-communism (see Easter 1997; Karl/Schmitter 1991; Lijphart 1992; McFaul 2002; Munck/Leff 1997; Przeworski 1991) build on a punctuated equilibrium analysis. Typically, such analyses distinguish between critical junctures – as agency-dominated periods that give rise to new institutions – and the subsequent periods of institutional stasis or consolidation. The logic of the latter, while having received considerably less attention, is explained in two main ways. Those who draw on a voluntarist perspective expect the newly established institutions to stabilize because of either sunk costs or the coordination and learning effects that they generate. Analyses closer to a structural perspective, on the other hand, explain the stability and reproduction of the new institutions in terms of formal rules, norms or conventions that often reflect particular historical legacies.<sup>4</sup> These differences notwithstanding, a common belief is that institutions, once established, set lasting pathways of future political processes (see Elster 1993: 175; Lijphart 1992: 208). By changing actors' incentive structures, institutions are expected to minimize the contingency of interactions and provide credible commitments to future policy outcomes. Institutions, in other words, are supposed to generate the sort of behavior and strategies that reinforce their own stability.<sup>5</sup> Guided by the premise that institutions produce stable patterns of exchange, such analyses, therefore, generally consider neither the possibility of a substantial deviation from institutional rules nor their potential modification in the absence of major exogenous shocks.

Much of the literature examining the development of the institution of postcommunist tripartism, while predominantly descriptive, implicitly follows this general logic. For instance, several accounts seem to employ a broad voluntarist reasoning when attributing the institutionalization of tripartism to the particular benefits of coordination, whether that be social peace, sustainable economic reforms or political stability (Héthy 1995: 40; Iankova 1998; Ládo 1996: 167; Mansfeldová 1995: 61). Others seem to draw on structural reasoning when emphasizing the importance of procedures or the “institutionalization of compromise” underpinned by norms of cooperation and legacies of union

---

4 The literature on critical junctures and path dependency is too extensive to be reviewed here. For some of the most comprehensive reviews of the concept and its application to the study of political-economic institutions, see Collier/Collier (1991); Mahoney (2000); Thelen (1999) and, in particular, Pierson (2000, 2004).

5 As elaborated by Greif and Laitin, such self-reinforcement denotes a process in which “more individuals in more situations would find it best to adhere to the behavior associated with [a particular institution]” (2002: 33–34).

participation (Iankova 2002: 9; Casale 1999a: 4, 14). Crucially, a good part of these studies relies on formal parameters of tripartism to derive conclusions about the resulting patterns of interaction or styles or policymaking. This line of reasoning has led some scholars to interpret the establishment of tripartite forums in CEE countries as a sign of the institutionalization of corporatist practices (Héthy 1994; Iankova 1998; Orenstein/Hale 2001; Pedersen/Ronit/Hausner 1993). Similarly, others have used the structure or formal functions of tripartism as a platform from which to either gauge general effects of the new institutions (Casale 1999a) or categorize the type of these new capitalisms according to some well-established typologies (Ágh 1996: 243; Reutter 1996).

But while the assumption that formal rules stabilize interaction patterns by generating particular behavior might correspond well to the so-called “parchment institutions”, such as constitutions and electoral laws, the same is questionable for peak-level tripartism. The former are generally capable of constraining actors’ choices and creating “powerful inducements that reinforce their own stability” (Pierson 2004: 150). In contrast, the self-reinforcement of tripartism is neither automatic nor facilitated by factors that are thought to ensure institutional reproduction, such as large set-up costs or veto points. Moreover, the ambiguity of rules governing postcommunist tripartite exchange presents potential impediments to the reinforcement of this institution. While formal institutional rules require policy deliberation, they stipulate no legal penalties for non-compliance with this principle.<sup>6</sup> Given these characteristics, this regulative institutional arrangement is likely to be malleable and open to interpretation in the post-design period.

Indeed, several accounts corroborate this argument empirically by revealing substantial variation in the enactment of these formally similar institutions across countries and over time (Avdagic 2005, 2006; Kohl/Platzer 2004; Seleny 1999; Stark/Bruszt 1998: chap. 6). This variation is evident with respect to the policy content and regularity of tripartite deliberations, their actual influence on the legislative and executive branch of the government, and the number and scope of agreements generated via these institutions.

---

6 This non-binding character of postcommunist tripartism has led some scholars to portray this arrangement as a toothless institution, window dressing, and “illusory corporatism” (see Crowley 2004; Ost 2000; Tatur 1995). These studies argue that, given the historically weak labor unions and the imperatives of economic adjustment, the lack of binding contracts engenders unilateralism by the government rather than corporatism. These arguments rightly point at drawbacks of analyses that assume particular institutional effects on the basis of formal rules and procedures of tripartism. Yet, paradoxically, they make the same mistake, for they also assume specific institutional effects (i.e. across-the-board government unilateralism), albeit on the basis of loopholes in the formal rules. Specifically, in emphasizing the universal weakness of organized labor, these studies fail to consider the capacity or power of the government. In doing so, they make a highly problematic (and empirically inaccurate) assumption that hedging and avoiding tripartite exchange is always without cost to the government. By unpacking the political dynamics of government–union interactions and paying more attention to their perceptions of relative power over time, this paper will show that government unilateralism is but one possible outcome of this exchange.

Agreements reached in these forums ranged from narrow issues such as minimum wages to comprehensive social pacts facilitating adjustment and spanning multiple policy areas. Consequently, the practical role of these institutions and the degree to which they have facilitated the inclusion of organized labor in the overall reform process has varied significantly across Central and Eastern Europe. Thus, evidently, the capacity of these institutions to shape strategies and ensure stable exchange has been rather weak. Instead of offering stable platforms for governing these young capitalisms, tripartite institutions themselves have often been subject to practical modification, while sometimes their very formal existence has been challenged.

Accounts relying on the punctuated equilibrium logic are incapable of explaining these developments. Because they treat institutions as a dependent variable at moments of critical juncture when new institutions are designed, and as an independent variable in the post-design period (see Krasner 1984: 240), such analyses commonly assume that new formal rules are capable of constraining behavior and generating predictable patterns of interaction (see also Carey 2000). In making this assumption, they overlook the possibility that young institutions might in fact be effects rather than causes of particular behavior (see also Alexander 2001). As the evident variation in the functioning of the formally similar tripartite institutions in postcommunist countries suggests, we might be well advised to shift the focus from the dominant analytical question of how formal institutions determine strategies and produce stable interaction patterns to the question of how actors' ongoing strategic maneuvering shapes the very meaning and functioning of newly established institutions.

This latter question has been central to a number of recent analyses concerned with gradual institutional change in advanced capitalisms (Crouch 2005; Crouch/Farrell 2004; Deeg 2005; Streeck/Thelen 2005a). Critical of the determinism inherent in the literature drawing on the punctuated equilibrium model, this new line of work calls for interactionist models aimed at a better conceptualization of the role of actors not only in the creation but also in the reproduction and practical modification of institutional arrangements. Institutions, in this view, are being continuously adjusted and modified by (boundedly) rational actors with different interests and power. Central to this literature is a concern with how actors interpret and use institutions so that they can generate different logics of action.

Even though relevant, this concern has received little attention in the scholarship on postcommunist political economies. This is all the more surprising given that young institutions in particular cannot be taken for granted since their meaning in practice, as Streeck and Thelen put it, requires elaboration through a sequence of strategic decisions (Streeck/Thelen 2005b: 30). It is precisely for this reason that theory-building on institutional development in these new capitalisms needs to rest on conceptual pillars that explicitly incorporate a more extensive role of strategic action in the post-design period. In the remainder of this paper, I contribute to this agenda by suggesting an actor-centered framework tailored to offer an analytical explanation of cross-country

variation in the development and functioning of formally similar peak-level corporatist-type institutions in Central and Eastern Europe.

### **The four pillars of an interactionist approach**

An interactionist approach attempts to capture the logic of ongoing strategic interactions and their consequences for institutional development. In particular, the approach outlined here is concerned with examining how the interactions that occur during market-building processes shape the development of newly created institutions that are to govern young market economies and structure regularized patterns of exchange.<sup>7</sup> The explication of the mechanism that drives the course of action in such situations requires four fundamental conceptual pillars.

The first pillar of the approach concerns the interplay between the structural context and strategic action in the process of institutional development. The structural context consists of two temporally defined parts. The first part refers to historical legacies, understood as a set of institutional, social, economic, and cultural characteristics that a given society inherits through the course of its development. With the transition to capitalism, this inheritance does not simply vanish. Instead, the historical context remains important in that it influences the initial constellation of actors, their goals and identities, and often the way in which they go about constructing the new social order. The second part of the structural context refers to the present structures, such as the organizational configuration of collective actors and the newly created institutional framework within which they operate. These arrangements define actors' resources or capabilities and provide rules intended to structure social action. However, neither the legacies nor the present structures alone fully determine actors' strategies. The impact of legacies weakens with time as actors react to the changing environment and adapt their strategies to new circumstances. At the same time, the constraining property of newly created institutions is not strong enough to produce predictable patterns of behavior and modes of interaction. In contrast to more established institutional settings (see, for instance, Scharpf 1997), the transitional context is characterized by less stable actor constellations and more malleable institutional structures. Such a situation allows a greater degree of freedom for actors to shape and modify the newly created institutions within which they act.

The second pillar of the interactionist approach relates to actors' preferences. To explicate the mechanism of interaction, it is necessary to distinguish between actors' preferences

---

7 In this sense, the proposed approach is problem-driven rather than method-driven. For the discussion of advantages of problem-driven approaches, see Green (1994), Levi (2002) and Scharpf (1997).

over institutional and policy outcomes and their core objectives. The former reflect actors' considerations about the relative desirability of corporatist-type deliberations and specific transformation policies. Such preferences are contextually and temporally defined and are influenced by factors such as economic considerations, specific historical legacies, and actors' values and ideological predispositions. As such, these preferences can vary not only across national contexts and over time but also among the same type of actors within the same context. For instance, union leaders might prefer different institutional and policy outcomes depending on whether they represent successor communist unions or unions that arose in opposition to communism. This is so because the way in which actors experience the historical context has bearings on their identities and cognitive frames, and thus on their subsequent preferences regarding appropriate institutional solutions and the role of the state in the economy.<sup>8</sup>

Different institutional preferences notwithstanding, it is reasonable to assume that both government officials and union leaders have the same underlying interests or core objectives: they are both interested in maintaining (or augmenting) their power because otherwise they might not be able to attain their preferred institutional and policy outcomes.<sup>9</sup> This assumption is crucial for it identifies the main mechanism of action and allows clear propositions about actors' strategies to be derived and then verified through empirical analysis. As a general rule, therefore, we should find that when, in the course of interactions, actors perceive a change in the relative power, they will adjust their institutional and policy preferences in a way that is likely to have the most advantageous or least disadvantageous consequences for their core objectives.

The third pillar of this approach is focused on the relationship between actors' rationality and the uncertainty of transitions. The complexity of simultaneous, large-scale economic and political transformations presents a formidable challenge to actors' ability to make optimal decisions and follow gain-maximizing strategies. If rational action

---

8 On the impact of norms and ideology on preference formation and change, see Levi (1998, 2005) and Vanberg (2002). For labor politics studies that call for a synthesis of institutionalist and constructivist arguments in explaining actors' strategies, see Hattam (1993), and Locke/Thelen (1995).

9 I am aware that, as any assumption about actors' core objectives, this one is also disputable. Indeed, there is no general agreement on whether politicians' core objectives are to secure office, policy, or votes (see, for instance, Müller/Strøm 1999), and whether they have short-term or long-term objectives. Similarly, the core objectives of union leaders might not be so clear-cut. For instance, they might be driven by ideological causes, have long-term objectives, or – especially when unions are encompassing – be interested in contributing to the overall economic efficiency and “making the pie the society produces larger” (Olson 1982: 42). However, making a specific assumption about actors' core objectives is necessary if one wants to derive empirically tractable propositions about their strategies and thus satisfy methodological concerns for parsimony. The assumption made in this paper, therefore, should be evaluated empirically. If empirical research reveals instances when government officials and union leaders refused to adjust their institutional and policy preferences despite the fact that pursuing such preferences presented a clear threat to their ability to maintain power, the proposed model would find itself on shaky ground.

in general is impeded by the “murkiness” of social life (see, for instance, Fligstein 1999), then it would be even more problematic to assume the existence of perfectly rational decision-makers in the exceptionally murky environment of postcommunist transitions. This is not to say that actors lack strategic acumen or that they act irrationally. On the contrary, actors seek to maximize their utility, but their ability to determine the optimal course of action is constrained by the uncertainty and fluidity of the transitional context.<sup>10</sup> Whereas under these constraints projecting the success of alternative courses of action is a daunting task, actors can and do make use of their reflexive properties (see also Emirbayer/Mische 1998; Hay/Wincott 1998; Simon 1998). Put simply, as the interactions proceed, actors rely on prior experience and accumulated knowledge when evaluating and adjusting their strategies to the exigencies of changing situations.

This discussion is directly related to the fourth and final pillar of the interactionist approach, namely the link between power perceptions and decisionmaking under uncertainty. When situational uncertainty is high, the actors’ ability to anticipate the response of others and to assign objective probabilities to alternative outcomes of interaction is limited. In more stable environments, the tendency is for institutions, trust, norms, and habits to serve as mechanisms that structure social interaction. In the transitional context, however, the potential of these mechanisms is significantly lower for two principal reasons. First, the newly established institutions typically do not constitute deep or stable equilibria (see Pierson 2004: chap. 5). This not only implies that such institutions might be more susceptible to modification but also that their capacity to reinforce particular behavior is weaker at the early stages of their development.<sup>11</sup> Second, the novelty of certain types of interaction, such as the corporatist-type exchange in post-communism, excludes the option of relying on either trust or established norms and practices to guide this process. Given the weakness of these mechanisms, actors’ choices in the uncertain context of transition are most likely to reflect their perceptions of relative power (see also Luong 2002). Such perceptions offer clues about the likely responses of others and thus help actors estimate the probable utility of alternative strategies.

These four pillars constitute all the elements necessary to derive an exposition of the development and enactment of new regulative institutions in post-communism. In a nutshell, they suggest that context-specific historical and structural conditions shape

---

10 This assertion evokes the concept of bounded rationality (Simon 1957). Even though this concept does not explicitly deal with situational uncertainty, it points to the limited cognitive capacity and computing ability of human agency. For a comprehensive review of the application of bounded rationality to several fields in political science, see Goodin (1999). The notion of bounded rationality figures most prominently in a number of organizational studies (see March 1978, 1994; March/Olsen 1976), studies of political and governmental institutions (see Jones 1999, 2001) and, in particular, economic sociology (see Beckert 1996, 2002).

11 As Claus Offe has pointed out, institutions “must not only be known to exist, but ‘make sense’ to actors and even oblige them.” As long as actors lack a strong sense of loyalty to particular institutions, as is arguably the case with many newly created institutions in post-communism, they are unlikely to “submit to the obligations stipulated” (1996: 223).



actors' institutional and policy preferences, while actors' perceptions of their ability to attain such preferences without sacrificing their core objectives determine whether and how these preferences translate into strategic choices.

Interactions thus begin in a context where old formal rules and institutions have been scrapped overnight, while new ones are still not sufficiently embedded to secure credible commitments or to oblige actors to conform to them. In such a context, the interaction becomes a "game" in which interacting agents seek to push through their preferred view of economic transformation. Since the uncertainty erodes actors' ability to assess relative power accurately, they need to choose their strategies based on subjective beliefs about what others can do. Specifically, intentionally rational actors are likely to make their choices by relying on two sets of available indicators of power. First, they are likely to consider structural-organizational attributes, which in the case of government–union interactions include indicators such as the electoral strength of the government or the concentration, encompassingness, and partisan ties of unions. Such attributes present resources that indicate actors' potential capabilities and power. However, these attributes alone do not often provide a reliable or sufficient basis for the assessment of power. This is particularly the case in the erratic context of the early transition, where actors, such as unions and political parties, undergo significant internal reorganization and where their very configuration is less stable. To arrive at a more complete estimate of each other's capacity under such conditions, actors need to rely on additional behavioral indicators of power, such as the observed internal dynamics.<sup>12</sup> By combining these indicators, actors form their initial perceptions of relative power and decide on their strategies. As the interactions proceed, however, they regularly update their perceptions by evaluating the outcomes of previous actions, thus adjusting their strategies to new circumstances. In such an ongoing process, strategies chosen in individual rounds will, over time, shape an identifiable interaction pattern which is likely to govern future behavior and define the very institutions within which these interactions proceed.<sup>13</sup> What this pattern will eventually look like will depend on the specific balance of power that emerges through recurrent interactions between actors who are each trying to advance their specific institutional and policy preferences while securing their common core objectives.

---

12 By incorporating the internal dynamics as a key component for the assessment of power, my analysis departs from those that build on the power-resource approach, as elaborated by Korpi (1985, 2001). The latter generally neglects such indicators, relying heavily on structural attributes of power (see Korpi 1985: 33, 2001: 244). The lack of attention to the internal dynamics, however, risks conceptualizing interacting collective agents, such as organized labor or individual unions, as unitary in terms of institutional and policy preferences – an assumption that is problematic in the light of empirical evidence. Thus, while the framework proposed here concurs with the power-resource approach in that actors are intentionally rational and that their choices reflect calculations about relative power, it suggests that such calculations are much more complex. The model presented later in this paper clarifies in detail what such calculations entail for different actors.

13 As Jack Knight has argued, if the past pattern of interaction is recognizable and distinctive, it is likely that actors will identify it as an institutionalized rule (1992: 79).

More generally, the approach outlined here exemplifies how actors' perceptions of relative power gradually reduce the contingency of action by structuring particular patterns of interaction which shape the very meaning and relevance of new regulative institutions. The advantage of this approach is that it facilitates an analysis of the relationship between interactive processes and the development of institutions that is attentive to both general theory and the specificities of contexts. As such, the main pillars of this approach provide a useful guideline for a systematic analysis of the impact of recurring interactions between government officials and union leaders on the development of corporatist-type institutions in Central and Eastern Europe.

Below, I build on these pillars to propose a heuristic model of government–union interactions. This model advances concrete propositions about how particular combinations of institutional and behavioral factors influence actors' perceptions of their relative power, their subsequent strategies, and the direction of development of formally similar tripartite institutions. I capture the dynamics of government–union interactions as a continuum of strategic choices in consecutive time sequences. In this way, the model facilitates a systematic analysis of these interactions both across countries and over time.

Since my analysis concerns recurrent strategic interactions between actors who each seek to advance institutional and policy outcomes that serve their particular interests, the use of repeated non-cooperative games – especially in the extensive form – might seem intuitively useful. However, I choose to present government–union interactions in a non-formalized way because the specifics of the problem at hand suggest a limited value added of formal models. Two reasons in particular cast doubt on the potential of formal models for an analysis of the interactive processes that drive the development of postcommunist corporatist-type institutions. The first reason concerns the widely accepted assertion that formal tools of game theory are useful for addressing a range of problems in highly structured settings (Bates 1987: 704; Scharpf 1997: 105) and as such might not be well suited to analyzing government–union interactions in post-communism. In this context actor constellations are often unstable, and the interacting entities are far from being cohesive actors who share more or less similar and fixed preference ordering (see also Munck 2001; Pierson 2004: 60–63). Admittedly, some of these caveats can be integrated into a formal model, for instance by specifying different background conditions, and by changing payoff structures in each round of the game. Such a move, however, would add complexity, which would make the model less manageable and thus less useful for depicting the processes of government–union interactions and their impact on the development of tripartite institutions. Second, as elaborated above, because of the high uncertainty that characterizes the postcommunist context, actors need to update their perceptions of power and adjust their strategies as the interactions proceed. To build a formal model of decisionmaking in such circumstances would require an explicit use of Bayesian analysis – a technique that has been widely criticized as too



complex and artificial, and thus ill-equipped to accurately portray empirical reality (see Bates et al. 2000; Elster 2000; Morrow 1994: chap. 8).<sup>14</sup>

Given these considerations, building a heuristic model that identifies key factors influencing power perceptions and outlines a mechanism of how such perceptions affect actors' strategies and shape particular institutional paths would appear to be more appropriate. Such a strategy also allows us to incorporate a more solid empirical basis of actors' institutional and policy preferences, which better illuminates their particular choices. It is important to recognize, however, that greater attentiveness to the empirical basis of actors' choices does not imply that mere descriptions of government–union interactions are on offer. Rather, by following a broad rationalist reasoning, the heuristic model proposed below advances a set of falsifiable hypotheses with regard to the choice of actors' strategies. In doing so, the model elucidates how different sequences of choices generate distinct institutional paths of tripartism, which explain the varied functioning of these formally similar institutions.

## Shaping postcommunist tripartism: Modeling interactions

### Initial choices

The starting point for understanding the varied results of postcommunist tripartism is to identify factors that can account for cross-national variation of strategies at the very beginning of transition. In general, the first democratically elected governments have an interest in stabilizing the economy as soon as possible and introducing market reforms.<sup>15</sup> Given the necessity of reforms in such structurally distorted economies, as

---

14 Initial action in Bayesian models is dependent on beliefs about a particular situation, while the result of this action serves as a basis for calculating posterior probabilities of outcomes (for an overview, see Gelman et al. 1995). The explicit use of such models, however, is problematic when actors have different information or beliefs, and when they interact in highly unstable environments, such as early transition (see also Beckert 1996; Gilboa/Postlewaite/Schmeidler 2004). In addition, these models require actors to perform often highly complex calculations, which renders them less useful for explaining real-world decisionmaking. These drawbacks notwithstanding, the general reasoning of Bayesian analysis is useful for it provides a guideline for understanding how actors update their beliefs about relative power, and how such beliefs gradually stabilize and as such produce clear patterns of interaction or institutional paths.

15 Note that this discussion of government preferences at the onset of transition refers in particular to the so-called leading reformers in Central and Eastern Europe, all of which became members of the European Union in May 2004. International financial institutions, as well as Association Agreements which signaled the possibility of accession to the EU, presented a powerful set of constraints and incentives that worked against experimenting with alternative policy solutions. International organizations, however, were not the only reason why governments preferred not to dilute neoliberal policies through negotiations with unions. In most of these countries, the first democratically elected governments were composed predominantly of individuals who

well as the proclaimed goals of “catching up” and “joining Europe,” the governments in general would prefer to abstain from making substantial policy concessions to organized labor that could endanger the progress of reform. By the same token, they also generally prefer either weak corporatist-type arrangements or the opportunity to avoid their establishment altogether. At the same time, however, incumbent politicians prefer most of all to stay in power and are therefore interested in maintaining political stability. It follows that if they are to fulfill both goals simultaneously, they need to find an optimal strategy that would both appease unions and produce positive policy outcomes that would disarm potential challengers from the political opposition.

To be able to define the optimal strategy toward the unions, the government needs to know the power of unions to challenge the reforms. At the outset of transition, however, objective indicators of union strength, such as active union membership, tend to be unreliable and highly inflated. At the same time, as the government–union interactions start immediately following the regime change, the government cannot rely on previous experiences to gauge union power since the nature of these interactions during communism was entirely different. Under these constraints, the government is likely to form a judgment about the potential capacity of unions by relying on some observable indicators. Three indicators in particular are likely to influence the government’s perception of union power:

1. the degree of union concentration (unified/fragmented);
2. the existence of formal union–party ties (strong/partial/non-existent); and
3. the mode of inter-union dynamics (cooperation/conflict).

The degree of union concentration is an important indicator of the unions’ ability to coordinate various demands and to follow a clear bargaining strategy. A single, encompassing union is not only more likely to uphold agreements, but it also has a potentially higher capacity to disrupt the normal functioning of the economy should the government fail to take union interests into account. Thus, all things being equal, the existence of such an encompassing union structure is expected to increase the government’s incentive to follow a pragmatic, responsive strategy to the unions and to facilitate their meaningful inclusion in policymaking. Conversely, in cases of bipolar or multipolar models of unionism, the government is less likely to be responsive to union demands.

The second indicator that influences the choice of strategies is the existence of formal ties between unions and political parties. Ties to unions increase the incentives for incumbent politicians to try to convince union leaders of the necessity of reforms that might have harmful effects on union constituencies.<sup>16</sup> To secure their support, in-

---

belonged to the anti-communist opposition and who had long advocated the introduction of market principles. Indeed, the control of key ministries was usually given to economic teams who had promoted neoliberal economic policies anyway.

16 For excellent discussions of how and why union leaders have subordinated material interests of

cumbents are likely to offer direct side payments to union leaders (say, in the form of parliamentary and government positions) and sporadic concessions to particular union sections. Such strategy is rational because – given the imperatives of economic reforms and the incumbents' interest in achieving substantial economic recovery by the next elections – the estimated costs of these concessions appear lower than those associated with a fully-fledged corporatist exchange. Moreover, the inclusion of union leaders in the political structures of the state empowers the government with the argument that interests of labor are sufficiently represented. Because support from union leaders reduces the likelihood of a possible backlash against reforms, the government is likely to avoid corporatist institutional arrangements. In contrast, the absence of partisan ties precludes such a strategy, increasing the government's incentive to utilize more actively tripartite institutions.<sup>17</sup>

In addition to these structural attributes, a behavioral variable, namely the mode of inter-union dynamics is likely to enter the government's calculus when making strategic choices. Inter-union conflict and rivalry increases coordination problems and strengthens the government's position vis-à-vis organized labor, thus weakening its incentives to promote corporatist exchange and to cede to union demands. Depending on the particular context, the government in such cases may try to further undermine the power of unions either directly, by neglecting the corporatist exchange, or indirectly, by using specific organizational and political issues to further propel union divisions. Union cooperation, on the other hand, indicates a higher degree of union power, and diminishes the prospects of such union-adverse strategies.

Different combinations of these three indicators should therefore lead governments to make different choices in the initial period of transition ( $t_0$ ). If government strategies responded to two broad types – union-adverse (–) and union-favorable (+) – the three indicators should allow us to derive predictions about the type of the resulting strategy and its approximate intensity (strong, moderate, weak).<sup>18</sup> Table 1 portrays these alternative scenarios.

---

their rank and file to market reforms undertaken by their partisan allies in several Latin American countries, see Burgess (1999), Murillo (2001), Valenzuela (1991). For related discussions of how the catch-all character of labor-linked parties in post-communism affects their policy choices and reduces their commitment to labor interests, see Avdagic (2004), Innes (2002), and Orenstein (1998).

17 Similarly, whereas claims by unions associated with opposition parties are more likely to be dismissed by incumbent politicians as political attacks orchestrated by the opposition, demands from non-aligned unions are more likely to be properly addressed within the institutional framework of tripartism.

18 An estimate of the intensity of a particular strategy does not represent some absolute value. Rather, the intensity is judged in relative terms, i.e. by comparing strategies across countries at the onset of transition, as well as over time in the subsequent steps of the analysis.

Table 1 Expected government strategy at  $t_0$ 

Union-party links	Organizational structure of unions		Mode of union interaction	
	Single/Unified	Fragmented	Cooperation	Conflict
	Absent	+++	++	–
Partial	n.a.	+	--	
Strong	Indeterminate	n.a.	---	

In short, two polar scenarios, in the upper-left and the bottom-right cells, can be distinguished. The government is expected to opt for the most union-favorable strategy (substantial inclusion in policymaking and policy concessions) when faced with a single, encompassing, and politically non-aligned union. Conversely, in cases where competing unions have strong formal links to different political parties, the government is in an advantageous position and is likely to choose a strong union-adverse strategy (exclusion from policymaking, propelling inter-union rivalry and direct cooptation, low concessions).

Most of the remaining cells represent the in-between cases, where the two broad strategies are likely to have lower intensity than in the two polar cases. For instance, a moderate union-favorable strategy (moderate inclusion and policy concessions) is likely to be chosen when fragmented, politically independent unions cooperate with each other (+). A moderate union-adverse strategy (propelling rivalry and partial cooptation, weak inclusion and policy concessions) is expected when fragmented and conflicting unions have partial links to political parties, i.e. when only some unions are politically allied and when these links are not particularly strong (--). A mild union-favorable strategy (weak inclusion and policy concessions) is likely in cases with partly politically aligned and generally cooperative unions (+). Finally, a weak union-adverse strategy (propelling rivalry, weak inclusion and policy concessions) will be chosen when politically non-aligned unions have a conflicting or highly competitive relationship (-).

In situations where a single and cohesive union has strong formal ties to a political party, the strategy is more difficult to determine as it may be influenced by union size, leadership, the type of benefits offered to the party, and the government–opposition dynamics.<sup>19</sup> The two fields marked with “n.a.” denote unlikely cases. While the first one – corresponding to a single/cohesive and partially aligned union – is self-evident, it might be necessary to elaborate why the case of cooperative unions with strong ties to different political parties was improbable in East Central Europe. At the onset of transition, unions in countries with fragmented labor movements were usually at loggerheads over issues such as ideology and the role they played during communism. As the “old/new” or the “successor/anti-communist” axis represented the strongest division

19 Empirically, however, no such case was present in East Central Europe at the onset of transition.

between the unions, a cooperative relationship at the beginning of transition would have been highly unlikely if such unions entered into separate political alliances.

Following the choice of government strategy the unions can either support or oppose government policies. The strategy that the unions settle on is likely to reflect their respective views about transformation. In contrast to incumbent politicians who due to the imperatives of economic transformation come to share largely similar institutional and policy preferences, union preferences are likely to be influenced by their specific origin. More precisely, unions that initially arose in opposition to the communist regime are likely to be more tolerant or even supportive of market reforms that may adversely affect the material interests of their constituencies. Their initial support for such policies stems from cognitive frames and ideological views that they formed during their struggle against the communist regime. In this way, the past translates into present choices. Successor communist unions, on the other hand, face not only the direct costs of reforms and a generally negative image, but also a decreasing influence in enterprise decisionmaking and the prospect of losing significant material assets acquired during communism. Given these considerations and the related concern to minimize the decline of their membership, they are likely to prefer reforms that entail tangible and immediate compensation measures to general promises of long-term economic progress. Whether these preferences lead to actual opposition to government policies depends on how they perceive their capacity to obtain these preferences.

### Subsequent choices

The initial strategies do not necessarily remain unchanged. As the interactions proceed, actors will re-evaluate their previous choices and decide between “staying on course” or “strategy alteration.” According to the guidelines of the proposed approach, the choice of strategy at  $t_x$  is likely to be affected by two considerations: (a) the experience drawn from interactions at  $t_{x-1}$ , and (b) the current state of the world, reflecting in particular fluctuations in the economic conjuncture, the government–opposition dynamics, and the inter-union dynamics. Given the complexity of these considerations, predicting the exact type of strategy after the period  $t_0$  becomes increasingly difficult. However, basic assumptions of the model allow us to establish conditions that are likely to trigger a shift of strategies.

Table 2 provides a basic picture of the conditions that are likely to result in a shift of government strategy. Because the core objective of incumbent politicians is to maintain or augment their power, we should expect a change in their strategy when they encounter a credible threat to their ability to attain this objective. Accordingly, they are likely to shift from a union-adverse to a union-favorable strategy at  $t_x$  when they perceive their relative power as decreasing. Specifically, such an assessment is likely to be made when the union response at  $t_{x-1}$  presents a strong challenge to government policies, and when

Table 2 Conditions triggering change in government strategy

$t_{x-1} \rightarrow t_x$	General conditions	Specific considerations	
	Perceptions of own relative power	Previous experience	Current state of the world
UA $\rightarrow$ UF	Decreasing	Strong union response at $t_{x-1}$	Policy challenge (strong opposition)
UF $\rightarrow$ UA	Increasing	Weak union response at $t_{x-1}$	Policy consensus (weak opposition)

UA = union-adverse strategy; UF = union-favorable strategy.

the government faces a political crisis and its policies are challenged by an increasingly strong opposition. Conversely, if incumbents perceive a considerable increase in their relative power, they are more likely to shift from a union-favorable to a union-adverse strategy. This is likely to be the case when the interactions at  $t_{x-1}$  indicate union impotence, and when economic conditions deteriorate dramatically, thus generating a broad political consensus for non-negotiated reforms.

Establishing the conditions that underpin a shift in union strategy is more complex, not least because the institutional and policy preferences of these actors are more diversified. As elaborated above, early choices of unions between supporting and opposing government policies have often been colored by their respective origin and the associated identities. Crucially, the preferences of union leaders are often not the same as those of their constituencies (see Crouch 1982; Levi 2005). Union leaders, for instance, might prefer institutional and policy choices that offer ideological satisfaction and promise long-term gains for labor, while their rank and file might be interested primarily in maximizing their short-term material gains. Divergence between leaders' and members' preferences is likely to become particularly pronounced when unions have strong partisan ties to a governing party undertaking comprehensive market reforms (see also Burgess 1999; Murillo 2001). Because such alliances bring considerable personal rewards and often ideological satisfaction to union leaders, they will be inclined to support government policies even if these impose sacrifices on their constituencies.

However, like incumbent politicians who want to stay in power, union leaders primarily want to avoid being replaced by potential competitors (see also Murillo 2001). Accordingly, their strategies need to incorporate preferences of their rank and file, if not at all times, then certainly when facing the risk of replacement. Thus, the union's position and its relative power vis-à-vis the government is only one concern that union leaders have to take into account when evaluating their strategy at  $t_x$ . In addition, their choices will be affected by the response from their members, who may endorse the leadership choices or, alternatively, lend support to their internal competitors (vertical competition) or to other unions (horizontal competition).

Having these qualifications in mind, Table 3 identifies the basic conditions that are likely to generate a shift in union strategy. We should expect allied union leaders to withdraw

their support for government policies when their position is threatened by an increasingly strong vertical and horizontal competition, and when they witness a decline in the power of their government. Relevant indicators would include, for instance, protest actions organized by internal contenders, losing members to other unions, and an increasingly strong popular support for opposition parties. These conditions will induce a change in the strategy of allied leaders, because they signal a decline in their power to attain their institutional and policy preferences and their core objectives simultaneously. Since this situation also signals a decline in the government’s power, non-allied union leaders are likely to strengthen their opposition to government policies because their capacity to attain their institutional and policy preferences increases under such conditions. Conversely, the union leadership is likely to abandon opposition to government policies when the absence of a credible vertical and horizontal competition coincides with a situation of a broad-based policy consensus and a relatively strong government. Such conditions indicate a low threat to allied union leaders who derive personal benefits – in the form of either political rewards or ideological satisfaction – from supporting government policies. At the same time, this situation signals a decline in the capacity of non-allied union leaders to extract concessions from the government.

Table 3 Conditions triggering change in the strategy of union leaders

$t_{x-1} \rightarrow t_x$	General conditions		Specific considerations	
	Perceptions of own relative power		Horizontal and vertical competition	Current state of the world
	Allied	Non-allied		
S → O	Decreasing	Increasing	High	Policy challenge (strong opposition)
O → S	Increasing	Decreasing	Low	Policy consensus (weak opposition)

S= support for government reforms; O= opposition to reforms.

### Interaction outcomes: Distinct institutional paths

This model of choices emphasizes the relevance of perceptions of power. The conditions that signal a change in actors’ power serve as clues about the level of costs and benefits that they are likely to incur in the event of staying on course or, alternatively, of altering their strategy. Actors reflect upon these conditions because they help them estimate their ability to attain their preferred institutional and policy outcomes while securing their core objectives. In line with the assumptions outlined above, we should expect incumbent politicians and union leaders to choose a strategy that promises the most advantageous or the least disadvantageous consequences for their core objectives. Because previous responses to actors’ strategies affect their subsequent choices, over time such strategic maneuvering will produce particular institutional paths characterized by different patterns of government–union interactions. These paths, in turn, de-



termine the prospects of the corporatist-type exchange and the functioning of tripartite institutions as the main arenas that facilitate such exchange.

Figure 1 Path formation: possible plays over time

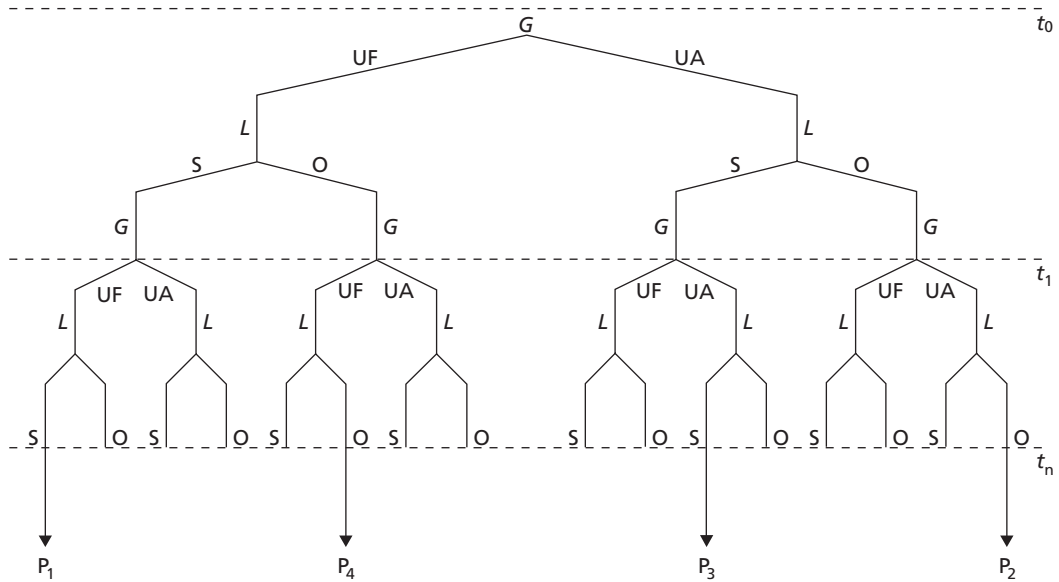

G = government; L = labor; UF = union-favorable; UA = union-adverse; S = support; O = opposition;  $P_1, P_2, P_3, P_4$  = institutional paths corresponding to the four ideal types of interaction patterns (see Table 4).

Figure 1 and the associated Table 4 identify possible paths that can be shaped through different combinations of actors' choices. To depict alternative paths, this schema simplifies significantly the interaction process by presenting it as an infinitely repeated encounter between two actors: government (G) and organized labor (L). In the domain of their interactions, each actor can choose from their action set (A) consisting of two basic types of strategies. Government can undertake reforms by following either a union-favorable or a union-adverse strategy,  $A(G) = \{UF, UA\}$ , and organized labor can in turn either support or oppose government policies,  $A(L) = \{S, O\}$ . In accordance with the model proposed above, each agent selects a strategy that appears the best option given their perceptions of their capacity to fulfill simultaneously their institutional and policy preferences and their core objectives. It follows that each round ( $t_x$ ) is characterized by a particular strategy combination ( $\omega$ ) belonging to a set of four possible strategy combinations  $\Omega = \{\omega_1, \omega_2, \omega_3, \omega_4\}$ , where  $\omega_1 = (UF, S)$ ;  $\omega_2 = (UF, O)$ ;  $\omega_3 = (UA, S)$ ; and  $\omega_4 = (UA, O)$ . Let us suppose that an institutional path is defined by the prevalence of a particular strategy combination played by the two actors over a certain period of time. Since the interactions in each round reflect a choice between the four possible strategy combinations, a repeated occurrence of the respective combinations over a number of rounds would shape four ideal institutional paths, represented by bold lines in Figure 1.



For example, when strategy combination  $\omega_1 = (UF, S)$  turns out to be dominant, we can assume that a path of pragmatic bargaining ( $P_1$ ) has been established. In this scenario,  $G$  predominantly follows some form of a union-favorable strategy by including  $L$  in the corporatist-type formulation of policies and reforms and offering some concessions, and  $L$  most of the time supports  $G$ 's course of action and policy choices. In contrast, the predominance of  $\omega_2 = (UA, O)$  would reflect a path of conflict ( $P_2$ ) in which  $G$  repeatedly attempts to exclude  $L$  from policymaking and thus to avoid potential concessions, while  $L$  most of the time responds with some form of opposition. The dominant play of  $\omega_3 = (UA, S)$  would lead to the establishment of a path of union cooptation ( $P_3$ ), reflecting the cases in which  $L$  usually supports  $G$ 's actions and non-negotiated policies despite generally adverse effects they might have for  $L$ . The prevalence of  $\omega_4 = (UF, O)$  denotes a path of state capture ( $P_4$ ). In this case,  $L$  – aiming to achieve a higher level of concessions – frequently opposes  $G$ 's actions and policies despite their relatively favorable character for  $L$ .<sup>20</sup> Finally, when no dominant strategy combination emerges prior to the period  $t_n$ , this pattern can be characterized as a path of unstable bargaining ( $P_x$ ). In Figure 1 this pattern would correspond to any of the branches that, after the second decision node for  $G$ , depart from the four ideal patterns, i.e. all the branches marked by thin lines.

Table 4 Strategy combinations and the resulting institutional paths

$\Omega = \{\omega_1, \omega_2, \omega_3, \omega_4\}$	$\omega_i / \sum \omega, t(0,1,\dots,n-1)$	$P, t_n$
$\omega_1 = (UF, S)$	$\omega_1 = \text{dominant} \Rightarrow$	$P_1 = \text{pragmatic bargaining}$
$\omega_2 = (UA, O)$	$\omega_2 = \text{dominant} \Rightarrow$	$P_2 = \text{conflictual relationship}$
$\omega_3 = (UA, S)$	$\omega_3 = \text{dominant} \Rightarrow$	$P_3 = \text{union cooptation}$
$\omega_4 = (UF, O)$	$\omega_4 = \text{dominant} \Rightarrow$	$P_4 = \text{state capture}$
	No dominant $\omega \Rightarrow$	$P_x = \text{unstable bargaining}$

Column 1 = a set of possible strategy combinations; column 2 = prevalence of a particular strategy combination in all strategy combinations observable from period  $t_0$  to  $t_{n-1}$ ; column 3 = resulting institutional paths at  $t_n$ .

It is unlikely, however, that a particular path will be shaped through the process where a single strategy combination is played in each round prior to  $t_n$ . As the interactions proceed under uncertainty, strategies in each round are formulated on the basis of actors' perceptions of power, which can change as they subsequently reflect upon responses to their previous strategy and shifts in relevant environmental conditions. As such perceptions change, so do the strategies. Put differently, "boundedly rational" and "reflexive" agents will try to use what they perceive as favorable moments or openings to modify or change their strategy so as to improve their position. Sometimes such actions are successful, and sometimes they are not, because uncertainty can produce misperceptions that result in ineffective strategies. Such misperceptions, though, are most likely in the

20 Note, however, that this scenario would be more relevant in the cases of very limited or stalled reforms, such as some of the former Soviet Union countries where state subsidies continued to be a prominent source of financing for many sectors of the economy.

early transformation when the world is in its most turbulent state and when actors are least capable of judging the power of others to challenge their preferred actions.

Over a number of rounds, however, actors learn about the likely capacity of their opponents from their responses in the previous rounds of interaction.<sup>21</sup> Initial perceptions or subjective beliefs about the opponent's power, if regularly confirmed by the observed reality, are likely to become accepted as their objective power, thus influencing the pattern of future interactions.<sup>22</sup> Perceptions, nonetheless, continue to be important, but mainly for estimating how environmental shifts might affect the already accepted power balances. In other words, subjective beliefs become in effect objectified when, in the course of a repeated play, perceptions of relative power converge or become shared by the interacting agents.<sup>23</sup> As the perceptions of each other's power gradually stabilize, actors start behaving in a more obvious Bayesian way, thus revising their perceptions less frequently unless some major event challenges these beliefs.<sup>24</sup> Taken-for-granted beliefs about the balance of power, in turn, have a salient impact on the development of the institution of tripartism since they influence the way in which the actors are likely to continue playing the game. For instance, the greater the power asymmetries that become accepted in this process, the less the likelihood that the weaker actor will be able to change the pattern of interaction or redirect the established institutional path by altering their strategy.<sup>25</sup> Under conditions of large power disparities, the stronger actor is unlikely to perceive such a strategy shift as a credible threat to its own goals because the record of past interactions indicates the other actor's limited capacity to significantly alter the terms of exchange unfavorable to their interests.<sup>26</sup> In sum, it is particular power balances that become accepted through repeated interaction that determine the terms of exchange in the corporatist-type forums and thus the very functioning and role of these institutions.

---

21 In this respect, *G* is in a better position than *L*. Since *L* is usually composed more or less of the same actors over  $t_n$ , *G* can draw lessons from its predecessor's experience with *L*. The situation is more difficult for *L* because these actors need to interact with an often-changing *G*.

22 I am indebted to Wolfgang Streeck for discussions on this point.

23 This corresponds to Aoki's (2001: 10) understanding of institutions as systems of shared beliefs about a way in which the game is repeatedly played according to the endogenous rules, i.e. the rules not determined formally, but rather "endogenously created through the strategic interactions of agents, held in the minds of agents, and thus self-sustaining."

24 I thank Colin Crouch for suggesting this formulation.

25 Strategy alteration reflects either a response to a change in environmental conditions or an endogenously driven change, such as the conscious effort to improve one's position through actions facilitated by some form of learning.

26 By the same line of reasoning, redirecting a path should prove less difficult when the perceptions of relative power have not yet stabilized. When the power balance is more even and widely accepted – which is the case with the path of pragmatic bargaining – actors will have strong incentives to remain on the path. Provided that actors seek to improve their position, the path of conflict is not likely to be sustainable in the long run. In this case, the actors would be expected to try shifting to a path that promises relatively higher gains. The resulting outcome, however, is not clear cut. The path of pragmatic bargaining is not the only possible outcome because the relative costs of a prolonged conflict might not be equal for both actors. Consequently, the

Some might object that differences in the pattern of interaction are not important as long as formal institutional rules are the same. Such arguments would interpret differences in the pattern of interaction as minor variation along the same broad path which is more or less determined by the formal properties of tripartite institutions. For instance, those emphasizing the comprehensive formal responsibilities of these institutions always see some form of corporatism (e.g. Iankova 1998), while those who stress the non-binding character of the agreements reached in these forums see primarily government unilateralism (e.g. Ost 2000). I argue, however, that this reliance on formal properties leads to false conclusions because it is precisely the way in which tripartite institutions are practiced that influences how actors subsequently interpret and further enact these institutions. Correspondingly, the proposed model suggests that, depending on the perceptions of relative power between government and unions, subsequent strategies adopted by these actors, and the resulting pattern of interaction that emerges through their repeated play, the institution of tripartism can be interpreted and enacted by actors in different ways. As a result, the role and impact of these formally similar institutions in policymaking may vary considerably across different contexts.

### **A guideline for applying the model**

This heuristic model captures the dynamism of government–union interactions and facilitates a comparative analysis of the process of development of postcommunist tripartism. By contextualizing actors' institutional and policy preferences and allowing for their change, it is sensitive to both contextual and sequential elements of the analysis. At the same time, because it anchors actors' choices in their aspiration to maintain or augment their power, the model advances a set of falsifiable propositions with regard to strategic choices that incumbent politicians and union leaders make in the course of postcommunist transformation. In this way, the proposed framework corresponds to some recent calls for a synthesis of general theory and process-oriented narrative analysis (see Abbot 1992; Abell 1993; Kiser 1996; Levi 2002; Pedriana 2005).

In accordance with the specific propositions of the model, we should expect actors' choices to reflect their respective perceptions of how the dynamics of interaction affects their ability to fulfill their institutional and policy preferences while maintaining their power. For each actor, the model specifies the relevant factors that can be expected to shape these perceptions. As such, the model lends itself to an empirical test that can

---

actor who is more willing to bear these costs might continue with the same strategy hoping to be able eventually to dictate the subsequent terms of exchange – which, in other words, would mean shifting to a path with more asymmetric power balances. This reasoning is broadly in line with the logic of the Rubinstein's bargaining model (1982), which suggests that a more “patient” player has an advantage.

be undertaken by constructing analytical narratives that give explicit consideration to these factors. Such narratives would need to:

- test whether the initial choice of strategies corresponds to the expectations of the model, as outlined in Table 1;
- explore whether the shifts in actors' strategies in later rounds concur with the model's predictions, as specified in Tables 2 and 3; and
- identify the type of institutional path that has been generated through repeated interactions, as illustrated by Table 4.

Because the proposed model emphasizes the influence of specific historical-structural contexts on actors' institutional and policy preferences, such narratives necessitate engaging in a detailed analysis of the specifics of a place and time. A solid reliance on interviews, documents, the press, and secondary literature is essential if one wants to discern the origins of actors' institutional and policy preferences, their perceptions of relative power, their beliefs about available options, and their strategies.

This type of analysis, therefore, combines general and particular causal factors to explain the development of distinct institutional paths. While such analysis allows inductive inference of the impact of historical legacies and the structural contexts on actors' identities and their institutional and policy preferences to be included, it requires that narratives of interaction be constructed in line with predominantly deductive reasoning incorporated in the model of government–union interactions. In predicting particular strategies and specifying the conditions for strategy shifts, this model employs deductive reasoning to illuminate how and why a particular pattern of action unfolds in a causal sequence.

In a separate work I have evaluated this model by constructing analytical narratives of government–union interactions in the Czech Republic, Hungary, and Poland (Avdagic 2006). In demonstrating the formation of a path of pragmatic bargaining, unstable bargaining, and cooptation respectively, these narratives offer important insights into the varied development and role of formally similar corporatist-type structures in the three countries. An evaluation of the model through further empirical cases would require equally detailed analytical narratives. The guidance provided here could serve to discipline such narratives and thus render them theoretically coherent and comparable.

### **Conclusions: Power, perceptions and institutional development**

How strong is the constraining capacity of young institutions, and how can they coordinate behavior on a single path when their formal rules are ambiguous or the costs of non-compliance with these rules are low? In addressing this question, this paper has

criticized analyses that draw a sharp line between extraordinary times of change when new formal institutions are established and subsequent periods of institutional stasis in which behavior is purportedly driven by these new formal rules. Instead, this paper advances the argument that young institutions in particular cannot be taken for granted, as actors are more likely to perceive them as malleable. Consequently, as Streeck and Thelen have argued, actors might try to interpret and use such institutions in a way that advances their particular goals and purposes or bypass them when they appear to conflict with their interests (2005b: 19). Thus, rather than reading behavior off formal rules, our attention needs to be redirected to exploring the consequences of actors' ongoing strategic maneuvering for the functioning – and thus the eventual fate – of young institutions.

In this paper, I have attempted to do this by focusing on postcommunist peak-level tripartism – a formally similar institution whose functioning has varied significantly across national contexts. Understanding this variation in institutional development, I argue, requires unpacking the political dynamics of government–union interactions. I have shown how such interactions can be heuristically modeled as a sequence of strategic choices that government officials and union leaders make. In this model, different historical experiences and structural contexts influence actors' preferences with regard to the desirability of corporatist-type arrangements and specific policies, while the aspiration to maintain power defines their common underlying interests. Accordingly, the model posits that the choices that these actors make in the course of interaction reflect their perceptions of their ability to attain preferred institutional and policy outcomes without compromising their core objectives. Over time, this kind of strategic maneuvering is likely to reveal a mutually accepted balance of power, which then provides constraints and incentives for particular types of strategies. This balance of power, rather than formal rules, determines the actual terms of exchange and thus the enactment of this newly established institution. Hence, depending on the particular power balances that emerge through such interactions, the functioning of the formally similar corporatist-type institutions can differ considerably across national contexts.

The framework presented in this paper depicts the development and enactment of peak-level tripartism as a contentious process in which the participating actors try to push through their preferred outcomes of transformation, entailing different roles for this institution. As such, my framework resembles the power-distributional view of institutions, which conceptualizes institutional development as a contest over rules in which actors try to achieve institutional equilibria most favorable to their interests (Bates 1987; Knight 1992; Moe 1990). Two aspects, however, differentiate my framework from standard power-distributional accounts.

First, while such analyses predominantly focus on bargaining processes that characterize the design of major political institutions in particular (see, for instance, Colomer 1995; Frye 1997; Przeworski 1991), the focus here is less on struggles over formal rules, and more over the uses to which newly established corporatist-type institutions are

put. Given the ambiguity of formal rules of tripartism, the actual role assigned to this regulative institution can lay anywhere along the continuum from ensuring a comprehensive inclusion of unions in the formulation and implementation of reform policies to presenting a largely empty shell that facilitates the discussion without much impact on the shape of substantive policies. The contention here, therefore, is about the actual role and influence that such institutions have in shaping and governing these young capitalisms.

Second, accounts that explain institutional outcomes in terms of the distribution of power usually rely on quantifiable or objective measures of power. This is not only the case with rational choice analyses of the design of political institutions, which usually assess power on the basis of election results and pre-election opinion polls (see Frye 1997; Geddes 1996; Schedler 2002); structural analyses that link welfare state policies to the power of unions also employ quantifiable measures, such as union density, centralization, and participation of social-democratic parties in office (e.g. Hicks 1999; Huber/Stephens 2001). In contrast, my framework downplays such objective measures of power and emphasizes instead *perceptions* of relative power. Objective measures are of little help if one wants to understand the logic of government–union interactions in post-communism, where initial power balances are neither known nor easily ascertained. In the context of such uncertainty, I argue, actors rely on their beliefs about relative power to gauge the likely response of others to various strategies, and to correspondingly choose a strategy that they believe would yield the highest utility. Because the development and enactment of corporatist-type institutions involves repeated interactions, actors regularly update such perceptions to estimate the potential costs and benefits of continuing or altering their previous strategies. When chosen strategies repeatedly yield expected results, a particular balance of power becomes mutually accepted or taken for granted. This power balance in turn determines how the institution of tripartism is subsequently practiced. My explication therefore concurs with the standard power-distributional accounts that institutional outcomes reflect particular power balances, while making an important clarification that those balances are not determined by some “objective” measure at the time of institutional establishment, but rather are “worked out” in the course of interactions.



## References

- Abbot, Andrew, 1992: From Causes to Events: Notes on Narrative Positivism. In: *Sociological Methods & Research* 20, 428–455.
- Abell, Peter, 1993: Some Aspects of Narrative Method. In: *Journal of Mathematical Sociology* 18, 93–134.
- Ágh, Attila, 1996: Meso-Politics in Central Europe: Fighting with the Infantile Disease in Europeanization and Democratization. In: Attila Ágh/Gabriella Illonszki (eds.), *Parliaments and Organised Interests: The Second Steps*. Budapest: Hungarian Centre for Democracy Studies, 241–252.
- Alexander, Gerard, 2001: Institutions, Path Dependence, and Democratic Consolidation. In: *Journal of Theoretical Politics* 13, 249–270.
- , 2004: *Power, Interests, and the Causal Effects of Institutions*. Paper presented at the Conference of Europeanists. Chicago, 11–13 March 2004.
- Aoki, Masahiko, 2001: *Toward a Comparative Institutional Analysis*. Cambridge, MA: MIT Press.
- Avdagic, Sabina, 2004: *Loyalty and Power in Union Party Alliances: Labor Politics in Postcommunism*. MPIfG Discussion Paper 04/7. Cologne: Max Planck Institute for the Study of Societies. <[www.mpi-fg-koeln.mpg.de/pu/abstracts/dp04-7.html](http://www.mpi-fg-koeln.mpg.de/pu/abstracts/dp04-7.html)>
- , 2005: State-Labour Relations in East Central Europe: Explaining Variations in Union Effectiveness. In: *Socio-Economic Review* 3, 25–53.
- , 2006: *Power Perceptions and Institutional Development: Government-Union Interactions in Post-communism*. Book Manuscript. Cologne: Max Planck Institute for the Study of Societies.
- Bates, Robert H., et al., 2000: Analytic Narratives. In: *Social Science History* 24, 685–696.
- Bates, Robert H., 1987: Contra Contractarianism: Some Reflections on the New Institutionalism. In: *Politics & Society* 16, 387–401.
- Beckert, Jens, 1996: What Is Sociological about Economic Sociology? Uncertainty and the Embeddedness of Economic Action. In: *Theory and Society* 25, 803–840.
- , 2002: *Beyond the Market: The Social Foundations of Economic Efficiency*. Princeton, NJ: Princeton University Press.
- Burgess, Katrina, 1999: Loyalty Dilemmas and Market Reform: Party-Union Alliances under Stress in Mexico, Spain, and Venezuela. In: *World Politics* 52, 105–134.
- Carey, John M., 2000: Parchment, Equilibria, and Institutions. In: *Comparative Political Studies* 33, 735–761.
- Casale, Giuseppe, 1999a: Tripartism and Industrial Relations in Central and Eastern European Countries. In: Giuseppe Casale (ed.), *Social Dialogue in Central and Eastern Europe*. Budapest: International Labour Organization, Central and Eastern European Team, 1–36.
- Collier, Ruth Berins /David Collier, 1991: *Shaping the Political Arena: Critical Junctures, the Labor Movement, and Regime Dynamics in Latin America*. Princeton, NJ: Princeton University Press.
- Colomer, Josep, 1995: Strategies and Outcomes in Eastern Europe. In: *Journal of Democracy* 6, 74–85.
- Crouch, Colin, 1982: *Trade Unions: The Logic of Collective Action*. Cambridge, UK: Fontana Paperback.
- , 2005: *Capitalist Diversity and Change: A Theory of Institutional Entrepreneurs*. Oxford: Oxford University Press.
- Crouch, Colin/Henry Farrell, 2004: Breaking the Path of Institutional Development? Alternatives to the New Determinism. In: *Rationality and Society* 16, 5–43.
- Crowley, Stephen, 2004: Explaining Labor Weakness in Postcommunist Europe: Historical Legacies and Comparative Perspective. In: *East European Politics and Societies* 18, 394–429.
- Deeg, Richard, 2005: Path Dependency, Institutional Complementarity, and Change in National Business Systems. In: Glenn Morgan/Richard Whitley/Eli Moen (eds.), *Changing Capitalisms? Complementarities, Contradictions and Capability Development in an International Context*. Oxford: Oxford University Press, 21–52.

- Easter, Gerald M., 1997: Preferences for Presidentialism: Postcommunist Regime Change in Russia and the NIS. In: *World Politics* 49, 184–211.
- EIRO, 2004a: *National-Level Tripartism and EMU in the New EU Member States and Candidate Countries*. European Industrial Relations Observatory On-Line. European Foundation for the Improvement of Living and Working Conditions. <www.eiro.eurofound.eu.int>
- Elster, Jon, 1993: Constitution-Making in Eastern Europe. In: *Public Administration* 71, 169–217.
- , 2000: Rational Choice History: A Case of Excessive Ambition. In: *American Political Science Review* 94, 685–695.
- Emirbayer, Mustafa/Ann Mische, 1998: What Is Agency? In: *American Journal of Sociology* 103, 962–1023.
- Fligstein, Neil, 1999: *Fields, Power, and Social Skill: A Critical Analysis of the New Institutionalisms*. Working Paper 01. Berkeley: University of California, Institute of Industrial Relations.
- Frye, Timothy, 1997: A Politics of Institutional Choice: Post-Communist Presidencies. In: *Comparative Political Studies* 30, 523–552.
- Garrett, Geoffrey/Barry R. Weingast, 1993: Ideas, Interests and Institutions: Constructing the European Community's Internal Market. In: Judith Goldstein/Robert O. Keohane (eds.), *Ideas and Foreign Policy: Beliefs, Institutions and Political Change*. Ithaca, NY: Cornell University Press, 173–206.
- Geddes, Barbara, 1996: Initiation of New Democratic Institutions in Eastern Europe and Latin America. In: Arend Lijphart/Carlos H. Waisman (eds.), *Institutional Design in New Democracies: Eastern Europe and Latin America*. Boulder, CO: Westview Press, 15–42.
- Gelman, Andrew, et al., 1995: *Bayesian Data Analysis*. London: Chapman & Hall.
- Gilboa, Itzhak/Andrew Postlewaite/David Schmeidler, 2004: *Rationality of Belief or: Why Bayesianism Is neither Necessary nor Sufficient for Rationality*. PIER Working Paper 04–011. Philadelphia, PA: University of Pennsylvania, Penn Institute for Economic Research.
- Goodin, Robert E., 1999: Rationality Redux: Reflections on Herbert A. Simon's Vision of Politics. In: James E. Alt/Margaret Levi/Elinor Ostrom (eds.), *Competition and Cooperation: Conversations with Nobelists About Economics and Political Science*. New York: Russell Sage Foundation, 60–84.
- Gould, Stephen J., 1982: The Meaning of Punctuated Equilibrium, and Its Role in Validating a Historical Approach to Macroevolution. In: Roger Milkman (ed.), *Perspectives on Evolution*. Southerland, MA: Sinauer, 83–104.
- Green, Donald P./Ian Shapiro, 1994: *Pathologies of Rational Choice Theory: A Critique of Applications in Political Science*. New Haven: Yale University Press.
- Greif, Avner/David Laitin, 2002: *How Do Self-Enforcing Institutions Endogenously Change? Institutional Reinforcement and Quasi-Parameters*. Unpublished Paper. Palo Alto, CA.
- Hattam, Victoria C., 1993: *Labor Visions and State Power: The Origins of Business Unionism in the United States*. Princeton, NJ: Princeton University Press.
- Hay, Colin/Daniel Wincott, 1998: Structure, Agency, and Historical Institutionalism. In: *Political Studies* 46, 951–957.
- Héthy, Lajos, 1994: Tripartism in Eastern Europe. In: Richard Hyman/Anthony Ferner (eds.), *New Frontiers in European Industrial Relations*. Oxford: Blackwell, 312–336.
- , 1995: Tripartism and Public Policy Formulation in Hungary. In: Robert Kyloh (ed.), *Tripartism on Trial: Tripartite Consultations and Negotiations in Central and Eastern Europe*. Geneva: International Labour Organization.
- Hicks, Alex M., 1999: *Social Democracy and Welfare Capitalism: A Century of Income Security Politics*. Ithaca, NY: Cornell University Press.
- Huber, Evelyne/John D. Stephens, 2001: *Development and Crisis of the Welfare States: Parties and Policies in Global Markets*. Chicago, IL: University of Chicago Press.
- Iankova, Elena, 1998: The Transformative Corporatism of Eastern Europe. In: *East European Politics and Societies* 12, 222–264.
- , 2002: *Eastern European Capitalism in the Making*. Cambridge, UK: Cambridge University Press.



- Innes, Abby, 2002: Party Competition in Postcommunist Europe – The Great Electoral Lottery. In: *Comparative Politics* 35, 85–104.
- Jones, Bryan D., 1999: Bounded Rationality. In: *Annual Review of Political Science* 2, 297–321.
- , 2001: *Politics and the Architecture of Choice: Bounded Rationality and Governance*. Chicago, IL: Chicago University Press.
- Karl, Terry Lynn/Philippe Schmitter, 1991: Modes of Transition in Southern and Eastern Europe, Southern and Central America. In: *International Social Science Journal* 128, 269–284.
- Kiser, Edgar, 1996: The Revival of Narrative in Historical Sociology: What Rational Choice Theory Can Contribute. In: *Politics & Society* 24, 249–271.
- Knight, Jack, 1992: *Institutions and Social Conflict*. New York: Cambridge University Press.
- Kohl, Heribert/Hans-Wolfgang Platzer (eds.), 2004: *Industrial Relations in Central and Eastern Europe: Transformation and Intergration. A Comparison of the Eight New EU Member States*. Brussels: European Trade Union Institute.
- Korpi, Walter, 1985: Power Resources Approach vs. Action and Conflict: On Causal and Intentional Explanations in the Study of Power. In: *Sociological Theory* 3, 31–45.
- , 2001: Contentious Institutions: An Augmented Rational-Action Analysis of the Origins and Path-Dependency of Welfare State Institutions in Western Countries. In: *Rationality and Society* 13, 235–283.
- Krasner, Stephen, 1984: Approaches to the State: Alternative Conceptions and Historical Dynamics. In: *Comparative Politics* 16, 223–246.
- , 1988: Sovereignty: An Institutional Analysis. In: *Comparative Political Studies* 21, 66–94.
- Ládo, Mariá, 1996: Continuity and Changes in Tripartism in Hungary. In: Attila Ágh/Gabriella Illon-szki (eds.), *Parliaments and Organized Interests: The Second Steps*. Budapest: Hungarian Centre for Democracy Studies, 158–172.
- Levi, Margaret, 1998: Conscription: The Price of Citizenship. In: Robert H. Bates et al. (eds.), *Analytic Narratives*. Princeton, NJ: Princeton University Press, 109–147.
- , 2002: Modeling Complex Historical Processes with Analytic Narratives. In: Renate Mayntz (ed.), *Akteure – Mechanismen – Modelle: Zur Theoriefähigkeit makro-sozialer Analysen*. Frankfurt a.M.: Campus, 108–127.
- , 2005: Inducing Preferences within Organizations: The Case of Unions. In: Ira Katznelson/Barry R. Weingast (eds.), *Preferences and Situations: Points of Intersection Between Historical and Rational Choice Institutionalism*. New York: Russell Sage Foundation, 219–246.
- Lijphart, Arend, 1992: Democratization and Constitutional Choices in Czecho-Slovakia, Hungary, and Poland, 1989–91. In: *Journal of Theoretical Politics* 4, 207–223.
- Locke, Richard M./Kathleen Thelen, 1995: Apples and Oranges Revisited: Contextualized Comparisons and the Study of Comparative Labor Politics. In: *Politics & Society* 23, 337–367.
- Luong, Pauline Jones, 2002: *Institutional Change and Political Continuity in Post-Soviet Central Asia: Power, Perceptions, and Pacts*. New York: Cambridge University Press.
- Mahoney, James, 2000: Path Dependence in Historical Sociology. In: *Theory and Society* 29, 507–548.
- Mansfeldová, Zdenka, 1995: Tripartism in the Czech Republic. In: Robert Kyloh (ed.), *Tripartism on Trial: Tripartite Consultations and Negotiations in Central and Eastern Europe*. Geneva: International Labour Organization, 60–78.
- March, James G., 1978: Bounded Rationality, Ambiguity, and the Engineering of Choice. In: *Bell Journal of Economics* 9, 587–608.
- , 1994: *A Primer on Decision Making: How Decisions Happen*. New York: Free Press.
- March, James G./Johan P. Olsen, 1976: *Ambiguity and Choice in Organizations*. Bergen: Universitetsforlaget.
- McFaul, Michael, 2002: The Fourth Wave of Democracy and Dictatorship: Noncooperative Transitions in the Postcommunist World. In: *World Politics* 54, 212–244.
- Moe, Terry M., 1990: Political Institutions: The Neglected Side of the Story. In: *Journal of Law, Economics, and Organization* 6, 213–261.

- Morrow, James D., 1994: *Game Theory for Political Scientists*. Princeton, NJ: Princeton University Press.
- Müller, Wolfgang C./Kaare Strøm (eds.), 1999: *Policy, Office or Votes? How Political Parties in Western Europe Make Hard Decisions*. New York: Cambridge University Press.
- Munck, Gerardo L., 2001: Game Theory and Comparative Politics: New Perspectives and Old Concerns. In: *World Politics* 53, 173–204.
- Munck, Gerardo/Carol Skalnik Leff, 1997: Modes of Transition and Democratization in Comparative Perspective. In: *Comparative Politics* 29, 343–362.
- Murillo, Maria Victoria, 2001: *Labor Unions, Partisan Coalitions, and Market Reforms in Latin America*. Cambridge: Cambridge University Press.
- Offe, Claus, 1996: Designing Institutions in East European Transitions. In: Robert E. Goodin (ed.), *The Theory of Institutional Design*. Cambridge, UK: Cambridge University Press.
- Olson, Mancur, 1982: *The Rise and Decline of Nations*. New Haven: Yale University Press.
- Orenstein, Mitchell A., 1998: A Retrospective: Václav Klaus: Revolutionary and Parliamentarian. In: *East European Constitutional Review* 7. <[www.law.nyu.edu/eecr/vol7num1/](http://www.law.nyu.edu/eecr/vol7num1/)>
- Orenstein, Mitchell A./Lisa E. Hale, 2001: Corporatist Renaissance in Post-communist Central Europe? In: Christopher Candland/Rudra Sil (eds.), *The Politics of Labor in a Global Age: Continuity and Change in Late-industrializing and Post-socialist Economies*. Oxford: Oxford University Press, 258–283.
- Ost, David, 2000: Illusory Corporatism in Eastern Europe: Neoliberal Tripartism and Postcommunist Class Identities. In: *Politics & Society* 28, 503–530.
- Pedersen, Ove K./Karsten Ronit/Jerzy Hausner, 1993: *Evolution of Interest Representation and Development of the Labour Market in Post-Socialist Countries*. Cracow: Cracow Academy of Economics.
- Pedriana, Nicholas, 2005: Rational Choice, Structural Context, and Increasing Returns: A Strategy for Analytic Narrative in Historical Sociology. In: *Sociological Methods & Research* 33, 349–382.
- Pierson, Paul, 2000: Increasing Returns, Path Dependence, and the Study of Politics. In: *American Political Science Review* 94, 251–268.
- , 2004: *Politics in Time: History, Institutions, and Social Analysis*. Princeton, NJ: Princeton University Press.
- Przeworski, Adam, 1991: *Democracy and the Market: Political and Economic Reforms in Eastern Europe and Latin America*. Cambridge, UK: Cambridge University Press.
- Reutter, Werner, 1996: Tripartism without Corporatism: Trade Unions in Eastern and Central Europe. In: Attila Ágh/Gabriella Illonszki (eds.), *Parliaments and Organized Interests: The Second Steps*. Budapest: Hungarian Centre for Democracy Studies, 59–78.
- Rubinstein, Ariel, 1982: Perfect Equilibrium in a Bargaining Model. In: *Econometrica* 50, 97–109.
- Scharpf, Fritz W., 1997: *Games Real Actors Play: Actor-Centered Institutionalism in Policy Research*. Boulder, CO: Westview Press.
- Schedler, Andreas, 2002: The Nested Game of Democratization by Elections. In: *International Political Science Review* 23, 103–122.
- Searle, John R., 1995: *The Construction of Social Reality*. New York: Free Press.
- Seleny, Anna, 1999: Old Political Rationalities and New Democracies: Compromise and Confrontation in Hungary and Poland. In: *World Politics* 51, 484–519.
- Simon, Herbert A., 1957: *Administrative Behavior*. New York: Macmillan.
- , 1998: What Is an “Explanation” of Behavior? In: Paul Thagard (ed.), *Mind Readings: Introductory Selections on Cognitive Science*. Cambridge, MA: MIT Press, 1–28.
- Stark, David/László Bruszt, 1998: *Postsocialist Pathways: Transforming Politics and Property in East Central Europe*. Cambridge, UK: Cambridge University Press.
- Streeck, Wolfgang/Kathleen Thelen (eds.), 2005a: *Beyond Continuity: Institutional Change in Advanced Political Economies*. Oxford: Oxford University Press.
- , 2005b: Introduction: Institutional Change in Advanced Political Economies. In: Wolfgang Streeck/Kathleen Thelen (eds.), *Beyond Continuity: Institutional Change in Advanced Political Economies*. Oxford: Oxford University Press, 1–39.

- Tatur, Melanie, 1995: Towards Corporatism? The Transformation of Interest Politics and Interest Regulation in Eastern Europe. In: Eckhard J. Dittrich/Gerdt Schmidt/Richard Whitley (eds.), *Industrial Transformation in Europe: Process and Contexts*. London: Sage, 163–184.
- Thelen, Kathleen, 1999: Historical Institutionalism in Comparative Politics. In: *American Review of Political Science* 2, 369–404.
- Valenzuela, Samuel J., 1991: *Labor Movements and Political Systems: A Conceptual and Typological Analysis*. Working Paper 167. Indiana: The University of Notre Dame, Hellen Kellog Institute for International Studies.
- Vanberg, Viktor J., 2002: Rational Choice vs. Program-Based Behavior: Alternative Theoretical Approaches and Their Relevance for the Study of Institutions. In: *Rationality and Society* 14, 7–54.

## Recent Titles in the Publication Series of the MPIfG

### MPIfG Discussion Papers

- DP 06/4  
H. Döring  
**The Composition of the College of Commissioners: Patterns of Delegation**
- DP 06/3  
S. Burkhart, P. Manow  
**Veto-Antizipation: Gesetzgebung im deutschen Bikameralismus**
- DP 06/2  
G. Jackson, R. Deeg  
**How Many Varieties of Capitalism? Comparing the Comparative Institutional Analyses of Capitalist Diversity**
- DP 06/1  
N. Bandelj  
**Cultural Understandings of Economic Globalization: Discourse on Foreign Direct Investment in Slovenia**
- DP 05/14  
R. Mayntz  
**Embedded Theorizing: Perspectives on Globalization and Global Governance**
- DP 05/13  
G. Möllering  
**Understanding Trust from the Perspective of Sociological Neoinstitutionalism: The Interplay of Institutions and Agency**

### MPIfG Working Papers

- WP 06/4  
Jens Beckert  
**Sind Unternehmen sozial verantwortlich?**
- WP 06/3  
A. Broscheid, D. Coen  
**Lobbying Systems in the European Union: A Quantitative Study**
- WP 06/2  
F. W. Scharpf  
**Nicht genutzte Chancen der Föderalismusreform**
- WP 06/1  
S. Ganghof  
**The Politics of Tax Structure**
- WP 05/10  
M. Höpner  
**Politisch-institutionelle Determinanten aktionärsorientierter Reformen**
- WP 05/9  
Aurora Trif  
**Collective Bargaining Practices in Eastern Europe: Case Study Evidence from Romania**
- WP 05/8  
F. W. Scharpf  
**No Exit from the Joint Decision Trap? Can German Federalism Reform Itself?**
- WP 05/7  
A. Trif, K. Koch  
**Strategic Unionism in Eastern Europe: The Case of Romania**

### MPIfG Books

- G. Möllering  
**Trust: Reason, Routine, Reflexivity**  
Elsevier, 2006
- W. Streeck, J. Grote, V. Schneider, J. Visser (eds.)  
**Governing Interests: Business Associations Facing Internationalization**  
Routledge, 2006
- J. Beckert, M. Zafirovski (eds.)  
**International Encyclopedia of Economic Sociology**  
Routledge, 2005
- M. Schludi  
**The Reform of Bismarckian Pension Systems: A Comparison of Pension Politics in Austria, France, Germany, Italy and Sweden**  
Amsterdam University Press, 2005
- A. Schäfer  
**Die neue Unverbindlichkeit: Wirtschaftspolitische Koordinierung in Europa**  
Campus, 2005
- G. Falkner, O. Treib, M. Hartlapp, S. Leiber  
**Complying with Europe: EU Harmonisation and Soft Law in the Member States**  
Cambridge University Press, 2005

### Ordering Information

#### *MPIfG Discussion Papers*

Order printed copies from the MPIfG (you will be billed) or download PDF file from the MPIfG website (free).

#### *MPIfG Working Papers*

Online at the MPIfG website.

#### *MPIfG Books*

At bookstores; abstracts on the MPIfG website.

[www.mpifg.de](http://www.mpifg.de)

Go to *Publications*.

### New Titles

Consult our website for the most complete and up-to-date information about MPIfG publications and publications by MPIfG researchers. To sign up for newsletters and mailings, please go to *Service* on the MPIfG website. Upon request to [info@mpifg.de](mailto:info@mpifg.de), we will be happy to send you our Recent Publications brochure.

### ERPA

MPIfG Discussion Papers and MPIfG Working Papers in the field of European integration research are included in the *European Research Papers Archive (ERPA)* which offers full-text search options: <http://eiop.or.at/erpa>.