

Direct measurement of the deep soil respiration accompanying seasonal thawing of a boreal forest soil

Adam I. Hirsch,¹ Susan E. Trumbore, and Michael L. Goulden

Department of Earth System Science, University of California, Irvine, California, USA

Received 5 June 2001; revised 8 October 2001; accepted 9 October 2001; published 25 October 2002.

[1] This paper presents data collected by an automated system designed to measure the seasonal cycle of both the quantity and isotopic composition of soil respiration. The results support the hypothesis that deep soil respiration at the BOREAS Northern Old Black Spruce site is sensitive to soil thaw and that much of this CO₂ represents decomposition of old organic matter, rather than simply root respiration. This is the first study to use a completely automated soil gas sampling system in the field to measure the soil CO₂ profile and collect samples of soil air for subsequent isotopic analysis. During the summer of 1999, deep soil respiration varied linearly with 50 cm temperature, with a slope of 0.2 kg C ha⁻¹ d⁻¹ °C⁻¹. Late in the season, this respiration was dominated by decomposition of old soil organic matter (fixed from the atmosphere centuries ago). This study has taken an important step toward clarifying the temperature sensitivity of deep soil CO₂ production in black spruce ecosystems through direct measurements within the soil and to quantify the seasonal variation of the relative contributions of recently fixed versus old carbon in deep soil respiration. *INDEX TERMS:* 0315 Atmospheric Composition and Structure: Biosphere/atmosphere interactions; 1615 Global Change: Biogeochemical processes (4805); 1694 Global Change: Instruments and techniques; *KEYWORDS:* biosphere/atmosphere interactions, biogeochemical processes

Citation: Hirsch, A. I., S. E. Trumbore, and M. L. Goulden, Direct measurement of the deep soil respiration accompanying seasonal thawing of a boreal forest soil, *J. Geophys. Res.*, 107, 8221, doi:10.1029/2001JD000921, 2002. [printed 108(D3) 2003]

1. Introduction

[2] Boreal forests cover about 14 million square kilometers in a circumpolar band between 50°N and 70°N, equivalent to about 10% of Earth's terrestrial surface area [Bonan and Shugart, 1989]. These forests contain a disproportionately large amount of soil carbon because of a climate very unfavorable to decomposition. Mean annual temperatures in the boreal forest are close to 0°C and drainage is generally poor due to low relief, fine soil texture, and in some areas, the presence of permafrost. In addition, the deep soil in mature forest stands is insulated from warm summer temperatures by a thick fibric layer composed of dead moss and fine roots ("shallow" carbon), which is consumed during fire, but regrows in subsequent decades. This insulation helps maintain permafrost, further impeding soil drainage in the region, and slows decomposition [Bonan, 1993; Bonan and Shugart, 1989] of soil organic matter.

[3] There is empirical evidence that higher air temperatures could lead to increased decomposition of organic matter stored deep below the moss surface. Automated

CO₂ flux chambers [Goulden and Crill, 1997; Goulden *et al.*, 1998] installed on the moss surface as part of the BOREAS project [Sellers *et al.*, 1997] detected an increase of below ground respiration of about 10 kg C per hectare per day between June and August 1996. This respiration increase was correlated with the temperature at depth but not moss temperature, leading to the inference that the higher deep soil respiration was related to seasonal thawing of the soil profile. Supporting the conclusions of Goulden *et al.* [1998], laboratory incubations suggest that organic matter stored deep in boreal and tundra soils is labile, with low decomposition rates resulting from cold, waterlogged soil conditions rather than chemical recalcitrance [Clein and Schimel, 1995; Dioumaeva *et al.*, 2002]. While a recent study has suggested that mineral soil organic carbon decomposition is insensitive to temperature [Giardina and Ryan, 2000], the studies cited above and the present work focus on the organic horizons that lie above the mineral soil, and contain the majority of the organic carbon stored in boreal soils underlain by clay soils or with drainage impeded by other factors [Trumbore and Harden, 1997].

[4] This paper presents results from an automated sampling system designed to measure the magnitude and isotopic composition of deep soil respiration at the BOREAS Old Black Spruce site (NOBS), using measurements taken from within the soil profile, rather than from above the moss surface. This sampling system is used to evaluate the

¹Now at Woods Hole Research Center, Woods Hole, Massachusetts, USA.

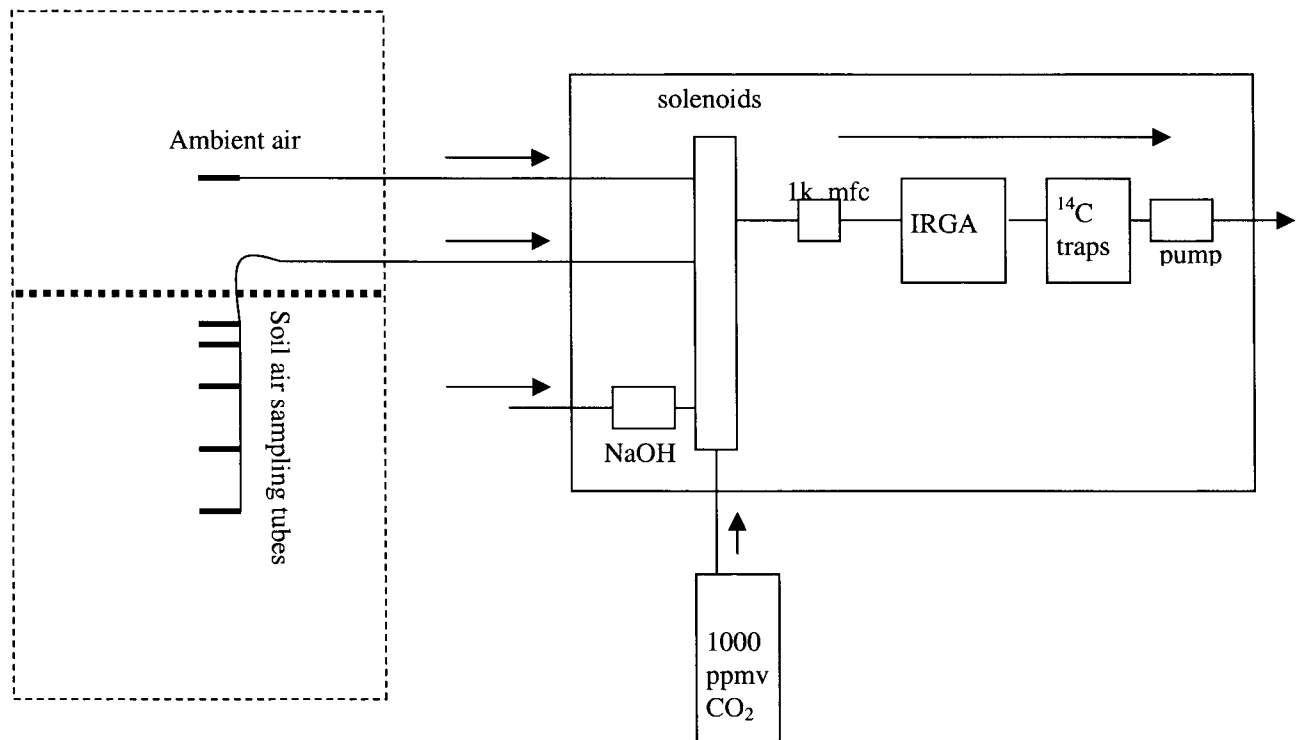

Figure 1. Diagram of automated sampling system.

temperature sensitivity of the deep soil respiration inferred by *Goulden et al.* [1998]. Our objectives are (1) quantify the relationship between respiration originating below 20 cm and temperature deep in the soil and (2) measure the isotopic composition of CO_2 deep in the soil, to distinguish whether respiration mainly originates from recently fixed carbon or from decomposition of organic matter fixed from the atmosphere centuries or millennia before the present. The distinction is important, because recently fixed carbon may be replaced quickly by interannual variation in productivity, while old carbon accumulates very slowly [*Trumbore and Harden, 1997*], and losses will not be replaced for a long time.

2. Methods

2.1. Site Characteristics

[5] The BOREAS Northern Study Area Old Black Spruce site in Northern Manitoba, Canada (NSA-OBS or NOBS, 55.88N, 98.48W) last experienced a stand-killing forest fire between 1850 and 1880 (about 150 years ago). The ground is covered by feather moss species (*Pleurozium schreberi*, *Hylocomium splendens*) in better-drained areas and *Sphagnum* species (*S. fuscum* and *S. warnstorffii*) in lower lying, more poorly drained areas. Well-drained areas are populated by dense, 10–15 m tall black spruce (*Picea mariana* (Mill) B.S.P.), while poorly drained areas are more open, with sparse 1–6 m tall black spruce and Tamarack (*Larix laricina*). The site's ecology and budgets of carbon, water and energy have been intensively studied as part of the BOREAS project since 1993. Spruce and moss net primary productivity and biomass [*Gower et al., 1997; Harden et al., 1997*], long-term average soil carbon dynamics [*Trumbore*

and *Harden, 1997*] and net ecosystem carbon exchange [*Goulden et al., 1997*] have all been quantified. A full suite of meteorological variables is continuously measured from the eddy covariance tower as part of the follow-on segment of the BOREAS project.

[6] The majority of soil carbon at the site resides in the Humic layer, below the historical depth of burning by forest fires. In imperfectly drained areas, this “deep carbon” totals 10–20 kg C m⁻² or about 75% of soil profile C [*Harden et al., 1997; Trumbore and Harden, 1997*]. This deep carbon is not mineral soil organic matter—it lies above the mineral soil. Percent carbon values in the clay underlying the Old Black Spruce site are very low, probably because roots do not penetrate the mineral soil. There are currently two definitions of “deep soil” for the boreal forest. One definition [*Trumbore and Harden, 1997*] is based on physical properties and radiocarbon-derived turnover time, and corresponds to the humic soil layer in the “Litter-Fibric-Humic” description. A second definition [*Goulden et al., 1998*], used in this paper, defines the deep soil as the depth below which the diel cycle of temperature does not penetrate, and thus is somewhat insulated from high summer temperatures (generally about 20 cm depth).

2.2. Automated Sampling System

[7] A diagram of the automated sampling system is shown in Figure 1. At each depth, air is withdrawn from the soil air-filled pore space by a KNF UNMP30 diaphragm pump through a 25 cm long piece of microporous Teflon tubing (International Polymer Engineering, Inc.). Though expensive, microporous Teflon tubing is useful in wet soils because it excludes liquid water while allowing gas

exchange. The microporous Teflon tubing also allows air to be drawn from the soil over the entire length of the tube (25 cm) rather than from a point, decreasing disturbance of the soil CO₂ profile. The soil air is drawn through 1/8" OD polyethylene tubing into a solenoid manifold, which selects between different depths (Clippard, Co.). The pump and solenoids are controlled by a Campbell Co. CR10X data logger, via Campbell CD-16 relay units.

[8] After entering the sampling system, the air is heated with a 50W heating pad, dried with a Nafion drier (Permapure, Inc.) and filtered with a Gelman 50 mm Teflon membrane filter. Flow is controlled by an MKS 1–1000 sccm mass-flow controller, with the set point controlled by the data logger. The soil air then passes through a LI-COR, Inc. 6252 IRGA, with the 1-min average CO₂ mV signal and sample cell temperature recorded by the data logger. The detection cell pressure is also monitored using an MKS Baratron absolute pressure sensor and the 1-min average recorded by the data logger. The system can be operated at pressures significantly below ambient, which allows measurement of soil CO₂ concentrations that exceed the usual limit of the IRGA (3000 ppmv) at 1 atm. The IRGA is zeroed once an hour using the same protocol as the profile sampling, but drawing air through a cylinder filled with soda lime rather than from the soil. The IRGA is also calibrated once an hour, again using the same sampling method, but by drawing air into the automated system from a calibration tank of 1000 ppmv CO₂ in air (Scott Specialty Gas).

2.3. Measuring the CO₂ Profile

[9] The automated soil CO₂ profile sampling system, described above, was installed at the NOBS site in mid-June 1999. Regular data collection began on 1 July 1999. Sampling tubes were installed at 0, 5, 10, 15, 23 and 30 cm under *Sphagnum* moss. The CO₂ profile was sampled three hours out of four at a sampling rate of 120 sccm. Each depth was sampled for 2 min, 1 min to flush the previous sample from the system and 1 min to record the concentration for the current sample. Because each depth was sampled for 2 min, it was possible to test whether the concentration remained steady during sampling or dropped, which would indicate that the gas sampling was influencing the CO₂ profile. Ambient air was sampled from 0.5 m above the moss surface. The CO₂ concentration is calculated by substituting the average of the IRGA mV signal from the second minute of sampling into the calibration equation provided by the LI-COR Company, with corrections for the sample cell pressure and temperature.

2.4. Collection of CO₂ for Isotopic Analysis

[10] After exiting the LI-COR, the sample air passes through a second solenoid manifold where stainless steel molecular sieve 13X traps [Bauer *et al.*, 1992] are connected to the system airflow in parallel. During the first minute of sampling, the sample air bypasses the molecular sieve traps while the system flushes the previous sample. During the second minute, the data logger places the trap corresponding to the sampled depth in line, quantitatively trapping a sample of the soil air for later isotopic analysis. Molecular sieve traps remain in place for 1–2 weeks, enough time to collect sufficient carbon for ¹⁴C analysis by accelerator mass spec-

troscopy (minimum 1 mg C, typically several mg C were trapped). When removed from the system, the CO₂ is desorbed at 450 C, purified cryogenically and reduced to graphite targets at the University of California at Irvine for ¹⁴C measurement at Lawrence Livermore National Laboratories [Vogel, 1992]. An aliquot of the sample is also measured for ¹³C at UC Irvine to correct the ¹⁴C data [Stuiver and Polach, 1977]. Delta ¹⁴C (Δ¹⁴C) is calculated as

$$\Delta^{14}\text{C} = (R_{\text{sam}}/R_{\text{std}} - 1) \times 1000 \quad (1)$$

R refers to the ¹⁴C/¹²C ratio of the sample ("sam") and standard ("std"). R_{sam} is corrected for mass-dependent fractionation by correcting all samples to a common δ¹³C of –25 per mil, and R_{std} is equal to the radiocarbon activity of wood in 1895, or 0.95 times the activity of the OX1 oxalic acid standard prepared in 1950 (R = 1.179 × 10^{–12} mol mol^{–1}). Therefore measurements using the standard today must be corrected for radioactive decay [see Stuiver and Polach, 1977]. Positive Delta values indicate the presence of "bomb" radiocarbon, released from aboveground thermonuclear tests in the 1950s and 1960s, while negative values indicate that carbon was fixed long enough ago to allow substantial radioactive decay of ¹⁴C (mean lifetime = 8267 years).

2.5. Environmental Monitoring

[11] T-type thermocouples (Omega, Co.) were installed at the same depths as the CO₂ profile sampling tubes and connected to a Campbell AM-25T multiplexer unit. The Campbell CR10-X data logger recorded temperatures every hour. Half-hour time step eddy covariance flux data, soil temperature, wind speed, momentum flux, precipitation and canopy CO₂ profile data were generously provided by Dr. Steven Wofsy's research group (for details of the eddy covariance system, see Goulden *et al.* [1997]).

2.6. Calculating CO₂ Flux

[12] One-dimensional flux calculations using CO₂ gradients generally use Fick's First Law:

$$\text{Flux} = -D_{\text{eff}} \delta C / \delta z \quad (2)$$

In order to calculate the CO₂ flux using Fick's First Law, one must estimate the effective diffusivity coefficient (D_{eff}) in addition to the CO₂ gradient (δC/δz). While Radon-222 is generally useful for determining gas transport [Davidson and Trumbore, 1995; Dorr *et al.*, 1983], it was not suitable for measuring diffusion in the top 30 cm of the NSA-OBS boreal forest soils for this study. Radon concentrations in the fibric layer near the surface are very low, requiring either large volumes of air or long counting times to achieve satisfactory counting statistics. Effective diffusivity can be calculated from air-filled porosity in the soil using the Millington equation [Davidson and Trumbore, 1995; Gaudinski *et al.*, 2000]:

$$D_{\text{eff}} = D_0 e^{4/3} (e/a)^2 (T/273)^{1.75} \quad (3)$$

In this equation, D_{eff} is effective diffusivity, D₀ is the diffusivity in air, e is the air-filled porosity, and a is total

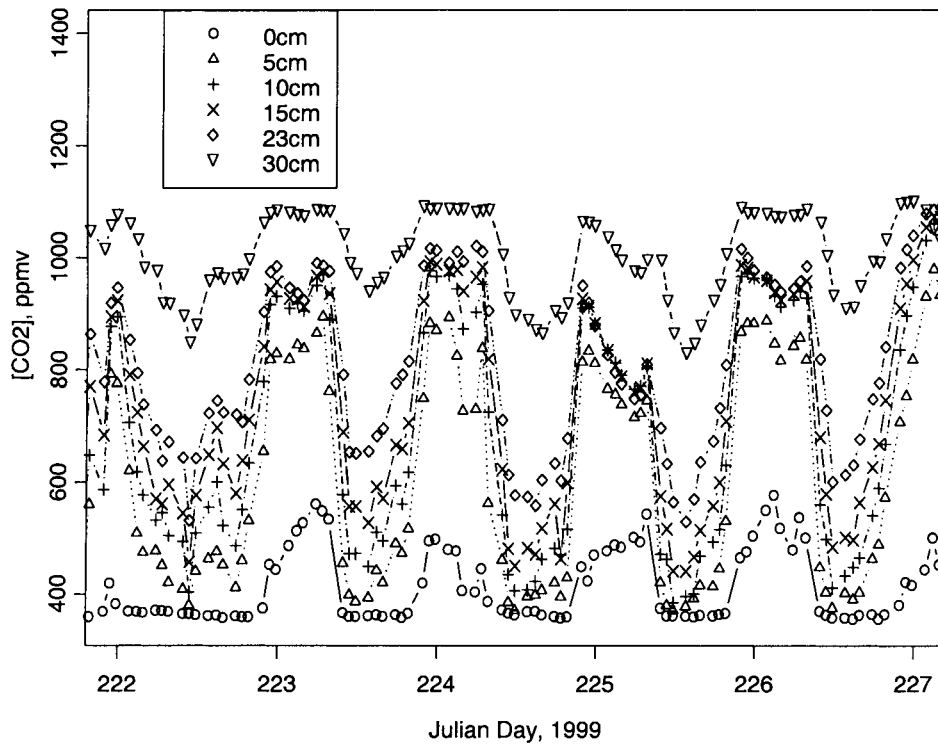

Figure 2. Diel cycle of the soil CO₂ profile from 10–15 August 1999.

porosity. At NOBS, air-filled porosity is roughly 80% at the surface and 60% at 20 cm (TGB-12 of *Newcomer et al.* [2000]), while total porosity is roughly $0.98 \text{ cm}^3 \text{ cm}^{-3}$ soil at the surface and $0.95 \text{ cm}^3 \text{ cm}^{-3}$ soil at 20 cm. Average temperature over the season is 10°C at 5 cm and 7°C at 20 cm. Using a value of $0.139 \text{ cm}^2 \text{ s}^{-1}$ for D_0 (at 273 K) [*Gaudinski et al.*, 2000] yields an effective diffusivity of about $0.07 \text{ cm}^2 \text{ s}^{-1}$ near the surface and $0.03 \text{ cm}^2 \text{ s}^{-1}$ at 20 cm depth. These values will vary over time with wetting and drying, but the top 20 cm is well drained due to the very high total porosity. Using a fixed effective diffusivity of $0.07 \text{ cm}^2 \text{ s}^{-1}$ and the observed CO₂ gradient in equation 2 yields a relationship between 5 cm temperature and surface CO₂ flux (see section 3, Figure 6) that resembles the *Goulden et al.* [1998] flux chamber results.

[13] The sensitivity of D_{eff} to air-filled pore space and temperature can be assessed by taking the first derivative of equation 3 with respect to each variable. An error in air-filled porosity of 10% (for example, if air-filled porosity were 50% at 20 cm rather than 60%) would cause an error in the calculated effective diffusivity of $0.02 \text{ cm}^2 \text{ s}^{-1}$ at 20 cm, and $0.03 \text{ cm}^2 \text{ s}^{-1}$ at 5 cm. Clearly, in future studies, air-filled pore space must be monitored, since these errors represent a large fraction of the calculated effective diffusivity. In contrast, effective diffusivity has low sensitivity to temperature.

[14] The CO₂ gradient between 15 and 23 cm under *Sphagnum* is used to calculate the flux at 20 cm (the boundary defining “deep soil” of *Goulden et al.* [1998]). The CO₂ flux at 20 cm is calculated using equation 2 only when the 5 cm CO₂ concentration is less than 420 ppmv. This selection is done because near-surface respiration is

great enough relative to deep respiration that at night the deep soil CO₂ gradient is swamped out by the storage of CO₂ produced near or above the surface. Only when the CO₂ stored in the profile is released during the day can the deep CO₂ gradient be assessed.

[15] An additional $0.3 \text{ kg C ha}^{-1} \text{ d}^{-1}$ is added to the flux at 20 cm calculated using equation 2, to account for the impact of sampling on the CO₂ profile. This is done because the sampling system underestimates the difference in CO₂ concentration between 23 and 15 cm by about 18 ppmv due to the impact of sampling on the CO₂ profile. Using an effective diffusivity of $0.03 \text{ cm}^2 \text{ s}^{-1}$, this gradient (2.3 ppmv cm^{-1}) is equivalent to $0.3 \text{ kg C ha}^{-1} \text{ d}^{-1}$. This correction was not performed on fluxes at the soil surface because there was no evidence that sampling affected the gradient.

3. Results and Discussion

3.1. Diel and Seasonal Cycles of Soil CO₂ and Temperature

[16] The daily rise and fall of soil CO₂ concentration (Figure 2) is very dynamic, and appears to be driven by day-night changes in transport. If changes were driven by respiration rate, the soil CO₂ profile would be expected to rise and fall with the diel pattern of temperature (Figure 3). Instead, CO₂ is released in the morning when the wind speed increases, and an accumulation when the wind ceases in the evening, so that the soil concentrations are completely out of phase with temperature. The entire CO₂ profile responds to changes in transport at the surface because respiration occurs mainly near the surface, where the temperature is warmest, and where moss and plant root

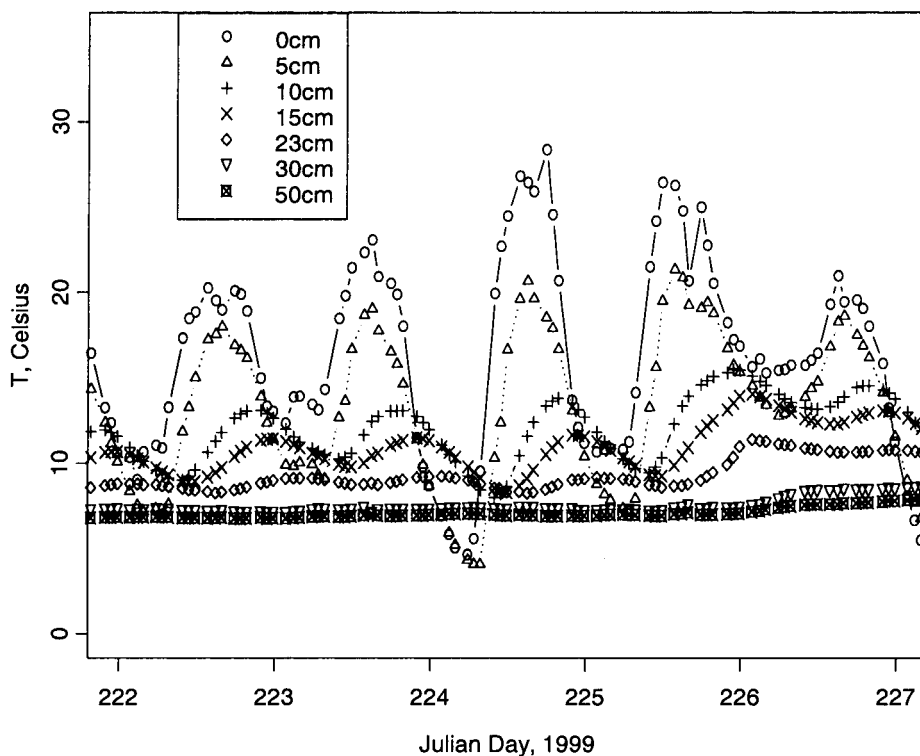

Figure 3. Diel cycle of the soil temperature profile from 10–15 August 1999.

respiration is concentrated. The tight coupling between the behavior of the CO_2 concentration at 20 cm and at the surface is strengthened by high air-filled porosity, and thus fast diffusion, in the top 30 cm.

[17] CO_2 concentrations in the soil under Sphagnum moss rise until about Julian Day 238 (26 August 1999) and fall thereafter (Figure 4). The concentration increases with depth over the entire season. The gap between Julian

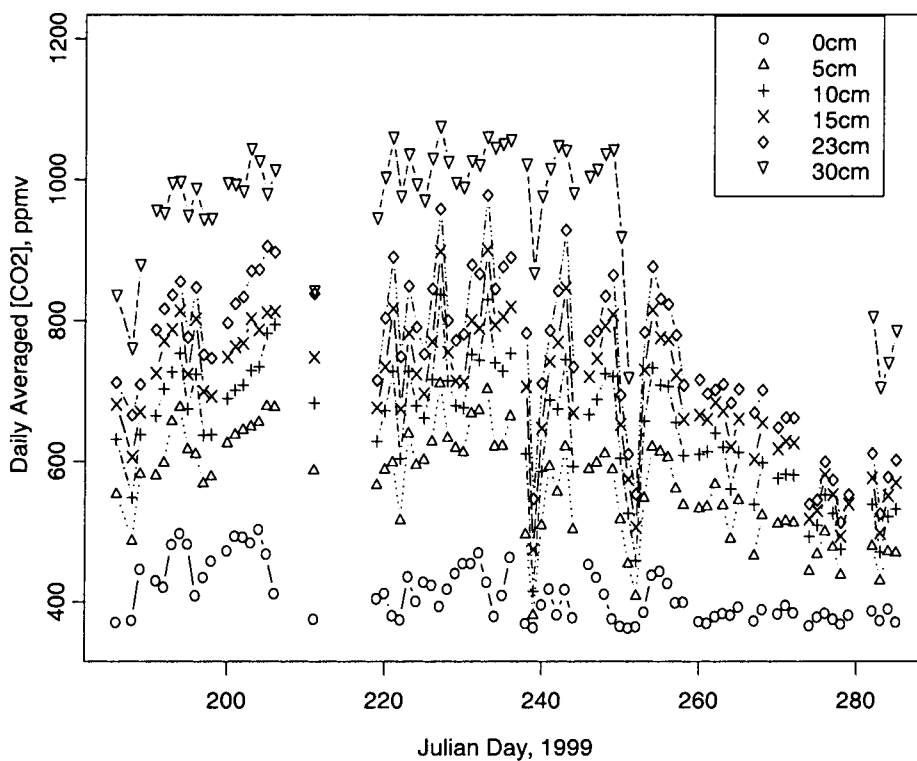

Figure 4. Seasonal cycle of the daily averaged CO_2 profile.

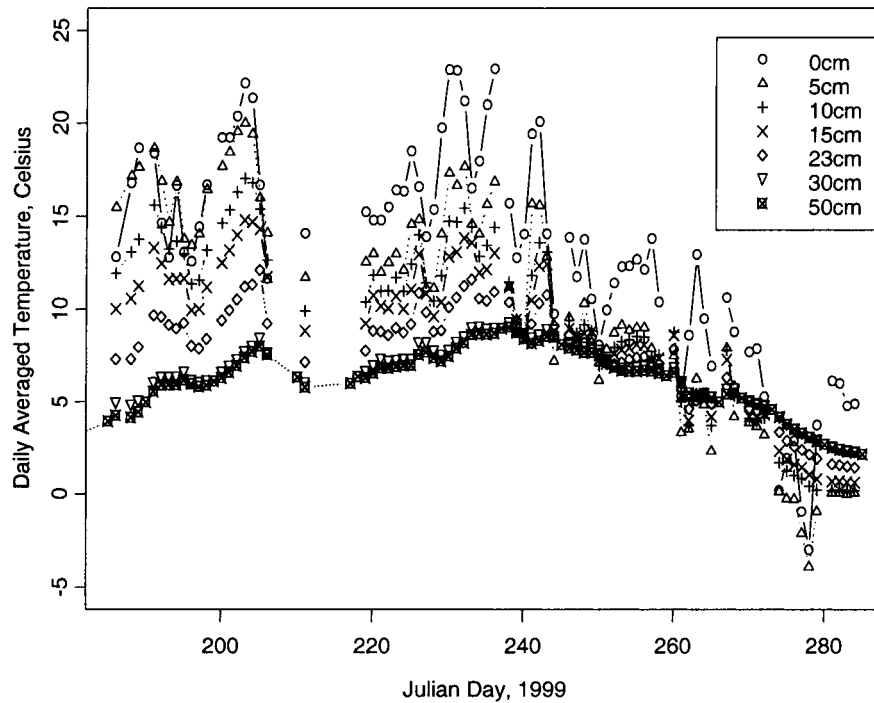

Figure 5. Seasonal cycle of the daily averaged soil temperature profile.

Days 206–218 (25 July to 5 August 1999) is due to condensation in the sampling system, which was corrected by installing a heating device on the sample lines where they enter the system box and on the IRGA. The gap in the 30 cm daily averaged CO_2 late in the season is due to water logging at that depth due to heavy rains, so that samples could not be drawn from the soil.

[18] There is also a distinct seasonal cycle of temperature (Figure 5). Daily average temperature is warmest at the surface and coldest at depth until about Julian Day 260 (17 September 1999), when the profile becomes isothermal and subsequently warmer at depth than at the surface. Maximum soil temperatures occur about Julian Day 240 (28 August 1999), the same time that soil CO_2 concentrations peak. Unlike the diel cycles of CO_2 and temperature, the seasonal cycles are in phase, implying that changes in respiration, related to changes in soil temperature, are driving the seasonal rise and fall of CO_2 . Of course, when quantifying respiration in the soil, it is necessary to use the CO_2 gradient with depth, rather than just the concentration, since below-ground concentrations will respond to changes in CO_2 above the soil surface related to atmospheric stability and respiration by aboveground vegetation.

3.2. CO_2 Fluxes at the Moss Surface and at 20 cm Below the Moss Surface

[19] The relationship between nighttime efflux of CO_2 from the moss surface, calculated using equation 2, and moss temperature (Figure 6) resembles the relationship between nighttime efflux and moss temperature measured by automated flux chambers [Goulden *et al.*, 1998]. Figure 6 only includes data when friction velocity (u^*) was below 0.2 m s^{-1} , so that transport is more likely to be diffusive (the condition for using Fick's First Law).

[20] The deep CO_2 flux below *Sphagnum* versus temperature at 50 cm over the whole season shows a linear relationship, with a range of $0.5\text{--}3.5 \text{ kg C ha}^{-1} \text{ d}^{-1}$ for a temperature range at 50 cm of 2° to 8° (Figure 7). The seasonal cycle of the 20 cm CO_2 flux shows up clearly when graphed as a function of time (Figure 8). The line in Figure 8 is the 20 cm flux calculated by substituting the 50 cm temperature into the best fit equation relating 20 cm flux versus 50 cm temperature (from Figure 7).

[21] The magnitude and temperature sensitivity of deep soil respiration is lower than previously observed. Temperature sensitivity of deep CO_2 flux to 50 cm temperature in the Goulden *et al.* [1998] study was approximately $1 \text{ kg C ha d}^{-1} \text{ }^\circ\text{C}^{-1}$. The sensitivity measured in this study is $0.2 \text{ kg C ha}^{-1} \text{ d}^{-1} \text{ }^\circ\text{C}^{-1}$. There are two explanations for the discrepancy. First, interannual variability or spatial variability in depth to water table could explain the difference. The soil profile studied here was often waterlogged below 30 cm. Second, the choice of diffusivity coefficient may have been too low. However, the entire discrepancy between the two methods cannot be explained by the diffusivity coefficient, because the effective diffusivity at 20 cm would have to be higher than the diffusivity in free air to fully remove the difference.

[22] It has been suggested that the high fluxes observed by Goulden *et al.* [1998] could have resulted from release of accumulated CO_2 produced by unfrozen deep soil and trapped below the seasonally frozen surface. This explanation seems unlikely because the "deep respiration" calculated by Goulden *et al.* [1998] continues to rise through the growing season, in a linear relation with deep temperature, rather than showing a pulse or step change in the flux corresponding to the transition of the surface layer from frozen to unfrozen.

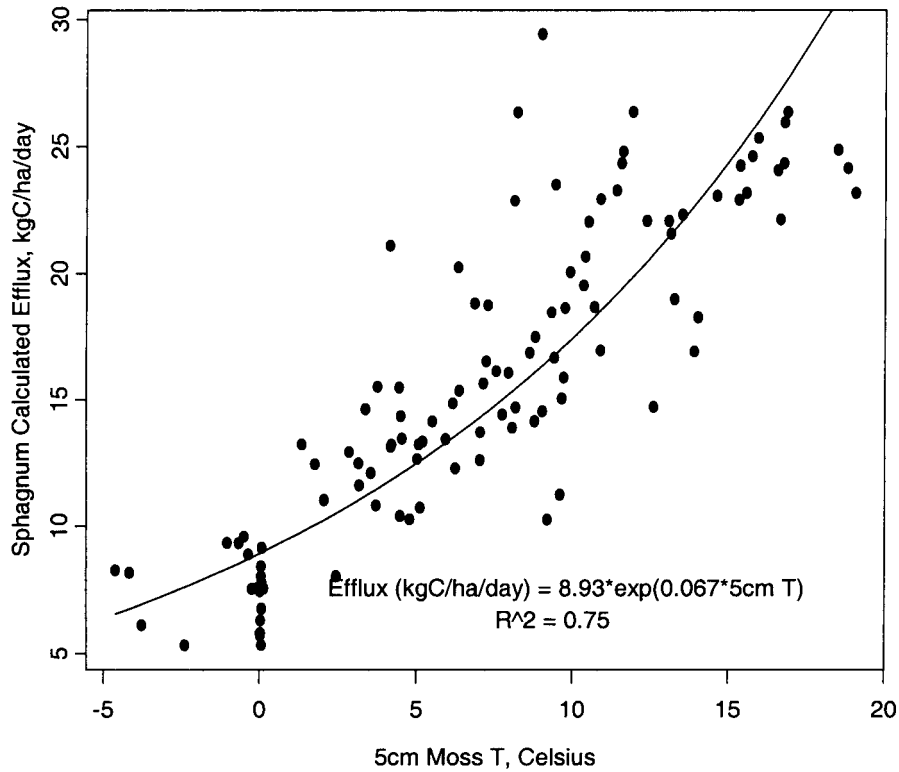

Figure 6. Calculated nighttime efflux versus 5 cm soil temperature.

[23] While the results of *Giardina and Ryan* [2000] appear at first to be at odds with the present results and conclusions of *Goulden et al.* [1998] study, the two results can be reconciled. *Giardina and Ryan* present results on the sensitivity of organic carbon in mineral soil to differences

in mean annual temperature. In contrast with their example, citing 70% of soil carbon in the boreal forest being in mineral horizons [*Liski et al.*, 1999], very little soil carbon is found in the clay mineral soil at the Old Black Spruce site, probably because spruce roots accumulate in a mat at

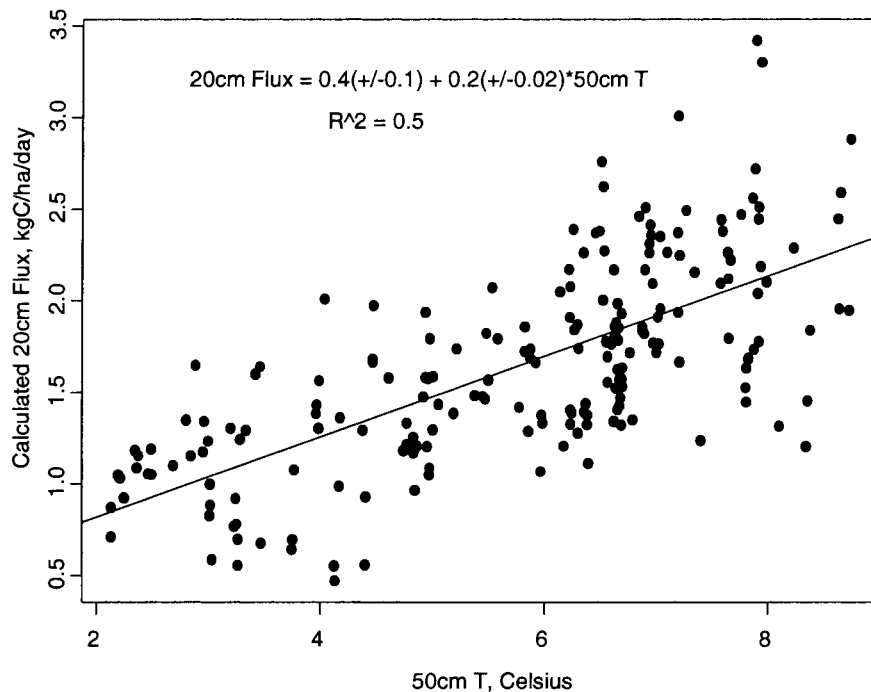

Figure 7. Deep soil respiration below 20 cm versus 50 cm soil temperature.

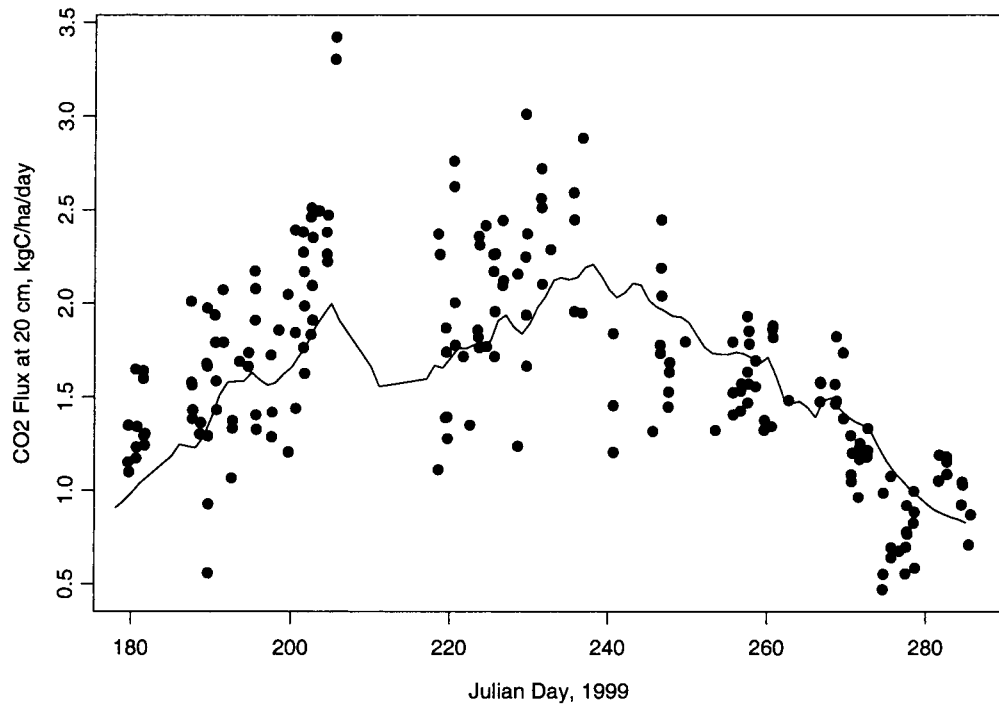

Figure 8. Seasonal cycle of deep CO₂ flux calculated from the CO₂ gradient (points) and predicted from 50cm temperature and the equation in Figure 7 (line).

the base of the organic layer, and do not penetrate the mineral soil (TGB-12 of *Newcomer et al.* [2000]). The vast majority of soil carbon overlays the mineral soil, and is labile, despite its very old radiocarbon age [*Clein and Schimel*, 1995; *Dioumaeva et al.*, 2002]. Therefore arguing that mineral soil carbon decomposition is insensitive to

temperature does not mean that decomposition in northern soils in general, and at the Old Black Spruce site in particular, is not sensitive to temperature.

[24] Using the least squares regression equations from Figures 6 and 7, the contribution of the soil below 20 cm to the total soil efflux during the entire growing season can

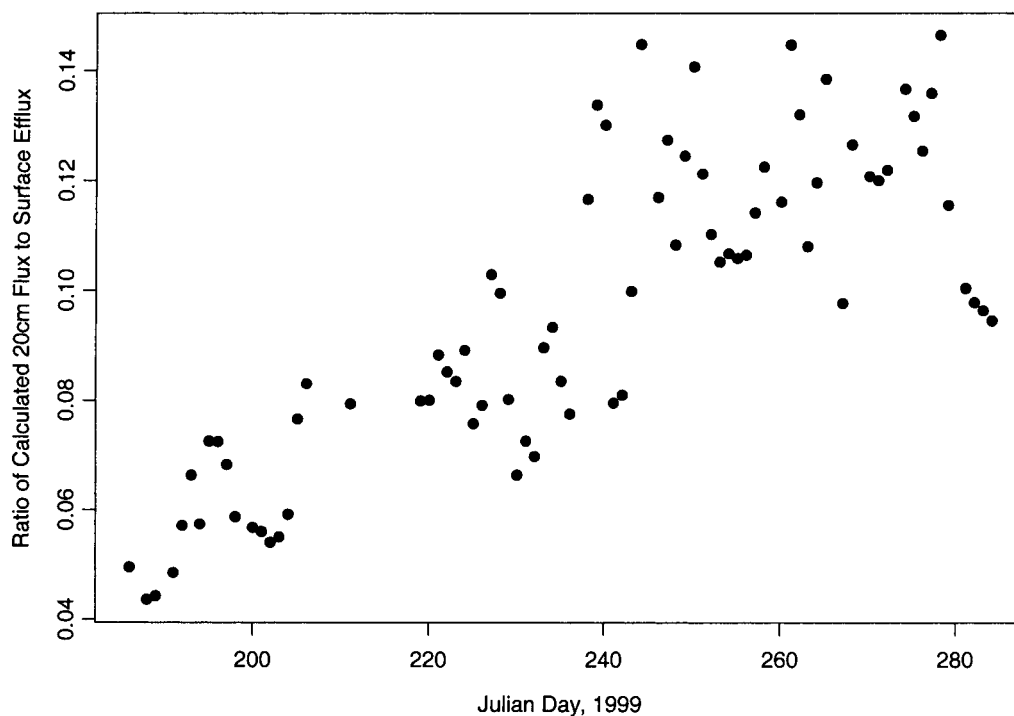

Figure 9. Ratio of 20 cm CO₂ flux to surface efflux using best fit curves in Figures 6 and 7.

Table 1. Summer and Autumn Soil $\Delta^{14}\text{C}$ at 23 cm Depth

| Date | $\Delta^{14}\text{C} \pm 5\%$ |
|----------------------|-------------------------------|
| 8–23 July 1999 | +111 |
| 9–22 August 1999 | +113 |
| 17–26 September 1999 | –4 |

be estimated. Substituting daily averaged temperatures from 5 and 50 cm into the best fit equations, the deep contribution to total CO_2 efflux rises from 5% at the beginning of July to 15% at the beginning of October (Figure 9). After September, the linear fit between the deep soil respiration and 50 cm temperature might not hold, since the temperature below 50 cm might remain elevated longer than the temperature at 50 cm, which begins dropping slowly at the end of August and more rapidly in mid-September.

3.3. Isotopic Signature of CO_2

[25] The $\Delta^{14}\text{C}$ of CO_2 collected at 23 cm decreases from +110 per mil in July down to –4 per mil in late September (Table 1). Each sampling interval represents two weeks of collection, except for the last interval, which is only one week. This shift in isotopic signature signals a shift in the source of CO_2 from a source dominated by recently fixed (post-1950) carbon to a source dominated by older (pre-1950) carbon and is consistent with the increasing contribution of the soil below 20 cm to total profile respiration (Figure 9), since carbon stored deep in the soil has a much lower ^{14}C signature [Trumbore and Harden, 1997]. It is possible that the old component of deep soil respiration represents decomposition of detritus from the last stand-killing fire, which occurred roughly 150 years ago, since fire events are the source of carbon for the deep soil layer [Trumbore and Harden, 1997; Harden et al., 2000]. Negative soil $\Delta^{14}\text{C}$ has been observed before at the NOBS site during late autumn and winter, when plant metabolic respiration has slowed or ceased and the surface litter layer has become colder than the deep soil [Winston et al., 1997; Trumbore, 2000].

4. Summary and Conclusions

[26] Measurements taken from July through October 1999 with an automated gas sampling system support the hypothesis that deep soil (>20 cm depth) respiration increases with warmer soil temperatures, and that a significant fraction of this CO_2 is produced from soil organic matter that was fixed from atmospheric CO_2 on the order of centuries before the present.

[27] This hypothesis is significant because boreal and arctic regions have been warming faster than the global average over the past 30 years. Atmospheric warming should increase deep soil temperatures, and hence release more carbon from organic horizons deep in the soil. While many soils have a small quantity of labile carbon that cycles quickly through the soil, imperfectly drained, mature boreal upland forests may contain a great deal of physically protected (cold and wet) soil organic matter that is otherwise labile [Dioumaeva et al., 2002]. The sensitivity of high latitude soils to climate change is a key factor in predictions of the boreal landscape carbon balance [Rapalee et al., 1998] and of future atmospheric CO_2 concentrations [Cox et

al., 2000]. The sampling system presented in this study should be useful in a range of other ecosystems for monitoring changes in soil respiration in response to changes in soil climate.

[28] **Acknowledgments.** The authors would like to thank Shuhui Zheng and Irina Dioumaeva at UC Irvine for radiocarbon sample preparation, Abigail Hirsch and Gloria Rapalee for assistance in the field, and two anonymous reviewers for their helpful comments. The work presented in this paper was supported by grants from the U.S. National Aeronautics and Space Administration (NAG5-7534 to Harvard University), the U.S. National Science Foundation (616F965 to UC Irvine), the U.S. Department of Energy (DE-F603-00ER63026 to UC-Irvine), the A.W. Mellon Foundation (to S. Trumbore), and by a NASA Earth System Science Fellowship (A. Hirsch).

References

- Bauer, J., P. M. Williams, and E. R. M. Druffel, Recovery of sub-milligram quantities of carbon dioxide from gas streams by molecular sieve for subsequent determination of isotopic natural abundance, *Anal. Chem.*, **64**, 824–827, 1992.
- Bonan, G. B., Soil temperature as an ecological factor in boreal forests, in *A Systems Analysis of the Global Boreal Forest*, edited by H. H. Shugart, R. Leemans, and G. B. Bonan, pp. 126–143, Cambridge Univ. Press, New York, 1993.
- Bonan, G. B., and H. H. Shugart, Environmental factors and ecological processes in boreal forests, *Annu. Rev. Ecol. Syst.*, **20**, 1–28, 1989.
- Clein, J. S., and J. P. Schimel, Microbial activity of tundra and taiga soils at sub-zero temperatures, *Soil Biol. Biochem.*, **27**(9), 1231–1234, 1995.
- Cox, P. M., et al., Acceleration of global warming due to carbon-cycle feedbacks in a coupled climate model, *Nature*, **408**, 184–187, 2000.
- Davidson, E. A., and S. E. Trumbore, Gas diffusivity and production of CO_2 in deep soils of the eastern Amazon, *Tellus, Ser. B*, **47**, 550–565, 1995.
- Dioumaeva, I., S. Trumbore, E. A. G. Schuur, M. L. Goulden, M. Litvak, and A. I. Hirsch, Decomposition of peat from upland boreal forest: Temperature dependence and sources of respired carbon, *J. Geophys. Res.*, **107**, doi:10.1029/2001JD000848, in press, 2002.
- Dorr, H., et al., CO_2 and radon 222 as tracers for atmospheric transport, *J. Geophys. Res.*, **88**(C2), 1309–1313, 1983.
- Gaudinski, J. B., S. E. Trumbore, E. A. Davidson, and S. Zheng, Soil carbon cycling in a temperate forest: radiocarbon-based estimates of residence times, sequestration rates and partitioning of fluxes, *Biogeochemistry*, **51**, 33–69, 2000.
- Giardina, C. P., and M. G. Ryan, Evidence that decomposition rates of organic carbon in mineral soil do not vary with temperature, *Nature*, **404**, 858–861, 2000.
- Goulden, M. L., and P. M. Crill, Automated measurements of CO_2 exchange at the moss surface of a black spruce forest, *Tree Physiol.*, **17**, 537–542, 1997.
- Goulden, M. L., et al., Physiological responses of a black spruce forest to weather, *J. Geophys. Res.*, **102**(D24), 28,987–29,008, 1997.
- Goulden, M. L., et al., Sensitivity of boreal forest carbon balance to soil thaw, *Science*, **279**, 214–217, 1998.
- Gower, S. T., et al., Carbon distribution and aboveground net primary production in aspen, jack pine, and black spruce stands in Saskatchewan and Manitoba, Canada, *J. Geophys. Res.*, **102**(D24), 29,029–29,042, 1997.
- Harden, J. W., K. P. O'Neill, S. E. Trumbore, H. Veldhuis, and B. J. Stocks, Moss and soil contributions to the annual net carbon flux of a maturing boreal forest, *J. Geophys. Res.*, **102**(D24), 28,805–28,816, 1997.
- Harden, J. W., et al., The role of fire in the boreal carbon budget, *Global Change Biol.*, **6**, 174–184, 2000.
- Liski, J., et al., CO_2 Emissions from soil in response to climatic warming are Overestimated—The decomposition of old soil organic matter is tolerant of temperature, *Ambio*, **28**(2), 171–174, 1999.
- Newcomer, J., et al. (Eds.), Collected data of the boreal ecosystem-atmosphere study (CD-ROM), NASA, Washington, D. C., 2000.
- Rapalee, G., S. E. Trumbore, E. A. Davidson, J. W. Harden, and H. Veldhuis, Soil carbon stocks and their rates of accumulation and loss in a boreal forest landscape, *Global Biogeochem. Cycles*, **12**(4), 687–701, 1998.
- Sellers, P. J., et al., BOREAS in 1997: Experiment overview, scientific results, and future directions, *J. Geophys. Res.*, **102**(D24), 28,731–28,770, 1997.
- Stuiver, M., and H. A. Polach, Reporting of ^{14}C data, *Radiocarbon*, **19**(3), 355–363, 1977.

- Trumbore, S. E., Age of soil organic matter and soil respiration: Radiocarbon constraints on belowground C dynamics, *Ecol. Appl.*, *10*(2), 399–411, 2000.
- Trumbore, S. E., and J. W. Harden, Accumulation and turnover of carbon in organic and mineral soils of the BOREAS northern study area, *J. Geophys. Res.*, *102*(D24), 28,817–28,830, 1997.
- Vogel, J. S., A rapid method for preparation of biomedical targets for AMS, *Radiocarbon*, *34*, 344–350, 1992.
- Winston, G. C., E. T. Sundquist, B. B. Stephens, and S. E. Trumbore, Winter CO₂ fluxes in a boreal forest, *J. Geophys. Res.*, *102*(D24), 28,795–28,804, 1997.
-
- M. L. Goulden and S. E. Trumbore, Department of Earth System Science, University of California, Irvine, CA 92697-3100, USA.
- A. I. Hirsch, Woods Hole Research Center, P.O. Box 296, Woods Hole, MA 02543, USA. (ahirsch@whrc.org)