

August 1976

Tokamak Limiter with Built
in Magnetic (Mirnov) Probes for
Temperatures of up to 450° C.

J.Gernhardt, H.-J.Berger, D.Groening,
H.Hohenöcker, F.Karger, H.
Kukral[†], K.Sahner, S.Schraub, J.
Stadlbauer, H.Volkenandt.

IPP III/26

August 1976



MAX-PLANCK-INSTITUT FÜR PLASMAPHYSIK

8046 GARCHING BEI MÜNCHEN

MAX-PLANCK-INSTITUT FÜR PLASMAPHYSIK

GARCHING BEI MÜNCHEN

Tokamak Limiter with Built
in Magnetic (Mirnov) Probes for
Temperatures of up to 450° C.

J.Gernhardt, H.-J.Berger, D.Groening,
H.Hohenöcker, F.Karger, H.
Kukral⁺, K.Sahner, S.Schraub, J.
Stadlbauer, H.Volkenandt.

IPP III/26

August 1976

⁺) Plasma Wall Interaction Group

*Die nachstehende Arbeit wurde im Rahmen des Vertrages zwischen dem
Max-Planck-Institut für Plasmaphysik und der Europäischen Atomgemeinschaft über die
Zusammenarbeit auf dem Gebiete der Plasmaphysik durchgeführt.*

J.Gernhardt, H. -J. Berger,
D.Groening, H.Hohenöcker,
F.Karger, H.Kukral, K.Sahner,
S.Schraub, J.Stadlbauer,
H.Volkenandt.

August 1976

Abstract

The design of a material limiter with built-in magnetic (Mirnov) probes is described in this report. These probes are used in Pulsator I for investigations of MHD modes and the horizontal plasma position.

The use of the proper material for the coil and connection wire is very important because of the high temperature rise of the limiter during the operation of the machine. The maximum measured limiter temperature was 350° C. The electrical circuit, mode signals $m=2$ and a soft disruptive instability are shown.

Table of Contents

	Page
Abstract	II
A) Introduction	1
B) Design of the limiter with magnetic probes	1
C) Temperature rise of the limiter during pulse cleaning and normal plasma shots	3
D) Electrical circuit and calculations	4
E) Experimental test results	5
Figure Captions	6

A) Introduction

In tokamaks Mirnov probes are used to measure the poloidal field strength and its rotation (modes, m , poloidal Fourier components) /1/. To detect frequencies as high as possible, the Mirnov coils should be placed inside the metal liner. The difficulty in this case is that the energy deposition on the probes during the plasma shots may be very high on these places. Therefore, the lifetime of the probes may not be guaranteed during the whole operation time of the device. When the probes are not removable from the torus, a repair is not possible without taking the machine completely apart.

It is not advisable to place the Mirnov probes in an opening of a diagnostic port because this place is needed for other diagnostics. Therefore, we used for Pulsator the limiter port to mount the Mirnov probes directly on the removable limiter.

B) Design of the limiter with magnetic (Mirnov) probes

The basic principle is to use a limiter with molybdenum segments screwed on a stainless steel ring and to place the magnetic probes between the ring and the molybdenum segments (limiter radius 11 cm). This prevents the magnetic probes from "seeing" the plasma. One sector of $2\pi/8$ could not be filled with a probe because of an RF antenna connection (Fig.1).

The problem with a limiter with built-in magnetic probes is the heat deposition. During the pulse cleaning and normal plasma shots in Pulsator the temperature of the external edge of the limiter is expected to rise more than 300° C. Therefore, care has to be taken to select the right materials for the probes.

Because of the good heat resistance and good machinability we used glass ceramic⁺⁾ for the slotted insulating coil body (Fig.1, Item 1). This material has a temperature coefficient of $\alpha = 9.4 \times 10^{-6} \text{ 1/}^\circ\text{C}$ and a maximum operation temperature of 1000°C with excellent vacuum properties. The wire which is wound around the machinable glass ceramic should have approximately the same temperature coefficient as the ceramic. Otherwise either the wire itself or the insulation for the wire will break or the wire will touch the shielding. Platinum rhodium⁺⁺⁾ wire (Pt/Rh 70/30 %) or titanium wire⁺⁺⁺⁾ could be used. Platinum rhodium wire would be better for vacuum application because no oxydation takes place. For cost reasons, however, we used titanium wire (0.254 mm diameter).

Figure 2 shows a drawing of the body of one magnetic probe. In Section A (Fig.2) one sees two 2 mm holes where the titanium wire is attached before it is wound in the slots around the machinable glass ceramic. Also shown on the front face of the coil form is the crossing of the wires. One of these crossing slots is 1 mm and the other slot 2 mm deep.

It should be noted that the winding - which starts on the left side of Fig.2 - uses the 2 mm deep slots, and the return winding (from the right to the left in Fig.2) the 1 mm slots. After these cross-sections are wound, the titanium wire is fixed with solder glass⁺⁺⁺⁺⁾ (Fig.1, Item 15) only on the front face at the ceramic. The 2 mm thick stainless-steel housing around the magnetic probe has a 1 mm slot so that the poloidal magnetic field can penetrate into the magnetic probe without delay. To reduce stray fields, the probe connections (Fig.1, Item 11) have to be twisted. In order to get good insulation of the twisted connections even for higher temperatures, glass ceramic elements with sloping drilled

-
- +) Machinable Glass Ceramic; 0.6 DM per cm^3 , Down Corning Glass NY, USA; delivered by: DISC Corporation, Stanford, Conn., USA.
 - ++) Platinum rhodium wire 0,25 mm \varnothing ; 25.--DM per meter; Degussa Hanau
 - +++) Titanium wire 0,254 mm \varnothing ; 20.--DM per meter; Materials Research München
 - ++++) Solder glass:Pyroceram 007024 available from SOVIREL, F-92306 LEVALLOIS PERRET, France; Down Corning Code 7575; sealing temperature 450°C

holes were used (Fig.1, Item 14). For further connection - when there is almost no thermal contact with the limiter - titanium wire and Kapton⁺) insulated copper wire is welded together (Fig.1; Item 12) with a graphite electrode. The Kapton wire was twisted (6 twists per cm cable length) and connected to the feed-through (Fig.1, Item 7). For even better vacuum conditions twisted thermo-coax-cable with Al_2O_3 insulation can be used⁺⁺). Another solution would be a vacuum tube with a twisted 2 pair Teflon cable inside the tube and a ceramic feed-through⁺⁺⁺).

A photograph of the complete limiter is shown in Fig.3. This limiter was tested up to 100 V. The titanium wire of all magnetic probes and the housing of the limiter withstood a voltage of 100 V DC without breakdown.

C) Temperature rise of the limiter during pulse cleaning and normal plasma shots

The temperature pattern of the described limiter in Pulsator during pulse cleaning was found to be the following: After venting the vacuum system, 500 shots of pulse cleaning by a plasma current of $J = 30$ kA (duration time $t = 2$ ms) brought a limiter temperature rise of $200^\circ C$ (base pressure $p = 2 \times 10^{-7}$ torr). When the vacuum chamber of Pulsator is clean again (basic pressure $p = 3 \times 10^{-8}$ torr) the limiter temperature rises by 500 shots of pulse cleaning up to $300^\circ C$ (repetition rate 4 seconds).

During normal plasma shots $J = 60$ kA (duration time $t = 120$ ms, repetition rate of 3 minutes) the temperature of the external limiter edge rises to $350^\circ C$ if the discharge is well centered. The temperature was measured with a thermocouple. After a certain time the magnetic probes will have approximately the same temperature as the limiter. In addition to

⁺) Polyimide (Habia Limburg) wire; outer diameter 0.51 mm; AWG 26; 0.50 DM per meter

⁺⁺) Philips (outer diameter 2 mm); 42.-DM per meter or LEICO Milano

⁺⁺⁺) Jenaer Glas Schott und GEN, Landshut, (feed-through diameter 4 mm)

this, the shadow regime behind the limiter is sometimes also subject to plasma discharges. As we have seen, a stainless-steel screw, still in the shadow of the limiter (10 mm), has melted.

D) Electrical circuit and calculations

The electrical circuit for the magnetic probes with active differential integrator is shown in Fig.4. The integrated signals from the different probes are led with weights (cosine, sine and other characteristics) to an analog computer for the detection of different movements and modes of the plasma (instead of using mode selective coils /2/). To reduce the induced voltage by coupling of stray fields, we used twisted and shielded 120 Ω cables. In the following, an example is given for the expected voltages induced in the magnetic probes using normal plasma parameters in Pulsator.

Cross-sectional area of magnetic probe $A = 9 \times 14 \text{ mm}^2 = 126 \times 10^{-6} \text{ m}^2$
Windings $N = 38$
Plasma current $J = 60 \text{ 000 A}$
Limiter radius $a_L = 0.11 \text{ m}$
Distance between magnetic probe and plasma center $g = 0.132 \text{ m}$
Poloidal magnetic field (toroidal effect neglected)

$$B_{\vartheta} = \frac{\mu_0 \cdot J}{2\pi g} = \frac{4 \cdot \pi \cdot 10^{-7} \cdot 6 \cdot 10^4}{2 \cdot \pi \cdot 0,132} = 0,0909 \text{ [T]} \hat{=} 909 \text{ [G]}$$

Induced voltage for $dt = 3 \text{ [ms]}$ (rise time of plasma current)

$$e = \frac{d\Phi}{dt} = A \cdot N \frac{dB_{\vartheta}}{dt} = \frac{126 \cdot 10^{-6} \cdot 38 \cdot 0,0909}{3 \cdot 10^{-3}} = 0,145 \text{ [V]}$$

Induced voltage using an active integrator with a time constant of $\tau = 1 \text{ [ms]}$

$$U_{\text{outp}} = A \cdot N \cdot \frac{B_{\vartheta}}{\tau} = \frac{126 \cdot 10^{-6} \cdot 38 \cdot 0,0909}{1 \cdot 10^{-3}} = 0,435 \text{ [V]}$$

During the disruptive instability of the plasma it is possible that the current change is 6 kA per 10 μs . This is equivalent to an induced voltage of $e = 13.05 \text{ V}$. From this

it can be concluded that the marginal induced voltage cannot be dangerous for the insulation of the magnetic probes.

E) Experimental test results

Nevertheless, the limiter with magnetic probes has worked so far without failure. An example is given in Fig.5. The oscillogram in Fig. 5a shows a weak disruptive instability. The oscillations which are shown are integrated signals from different magnetic probes showing directly the poloidal field strength variations. One can clearly see the movement of the plasma current center to the inside (towards probe 2) during approximately 0.4 ms (negative integrated signal means movement towards the appropriate probe). Superimposed on this movement is an $m = 2$ oscillation which has its maximum amplitude during the inward shift. The phase relation of the $m = 2$ is given in Fig.5b.

The high-frequency performance of the magnetic probe system is shown in Fig.6. Here a transient 1 MHz oscillation can clearly be detected as an $m = 0$ (poloidal), $n = 0$ (toroidal) oscillation. This means an oscillation in the plasma current during the leading edge of the negative voltage spike /3/.

The disruptive instability is still under investigation, for which the magnetic (Mirnov) probes are very useful.

References

- /1/ L.A. Artsimovich, Nuclear Fusion 2 (1972) page 235.
- /2/ L.C.J.M. DeKock et al., "Measurements of Poloidal Magnetic Field Perturbations in Alcator". Rijnhuizen Report 74-86 (October 1974)
- /3/ F. Karger et al., "On the Origin of the Disruptive Instability in the Pulsator I Tokamak". 1976 6th International Conference on Plasma Physics and Controlled Nuclear Fusion Research. Berchtesgaden West Germany.

Figure Captions

- Fig.1: Overall view and details of the limiter with magnetic probes
- Fig.2: Magnetic probe body with detail
- Fig.3: Photograph of the limiter with magnetic probes.
- Fig.4: Electrical circuit for the magnetic probes.
- Fig.5a: Oscillogram taken with probe limiter.
- Fig.5b: Phase relation of the $m = 2$ mode.
- Fig.6: High-frequency oscillogram (1 MHz)

Fig.1

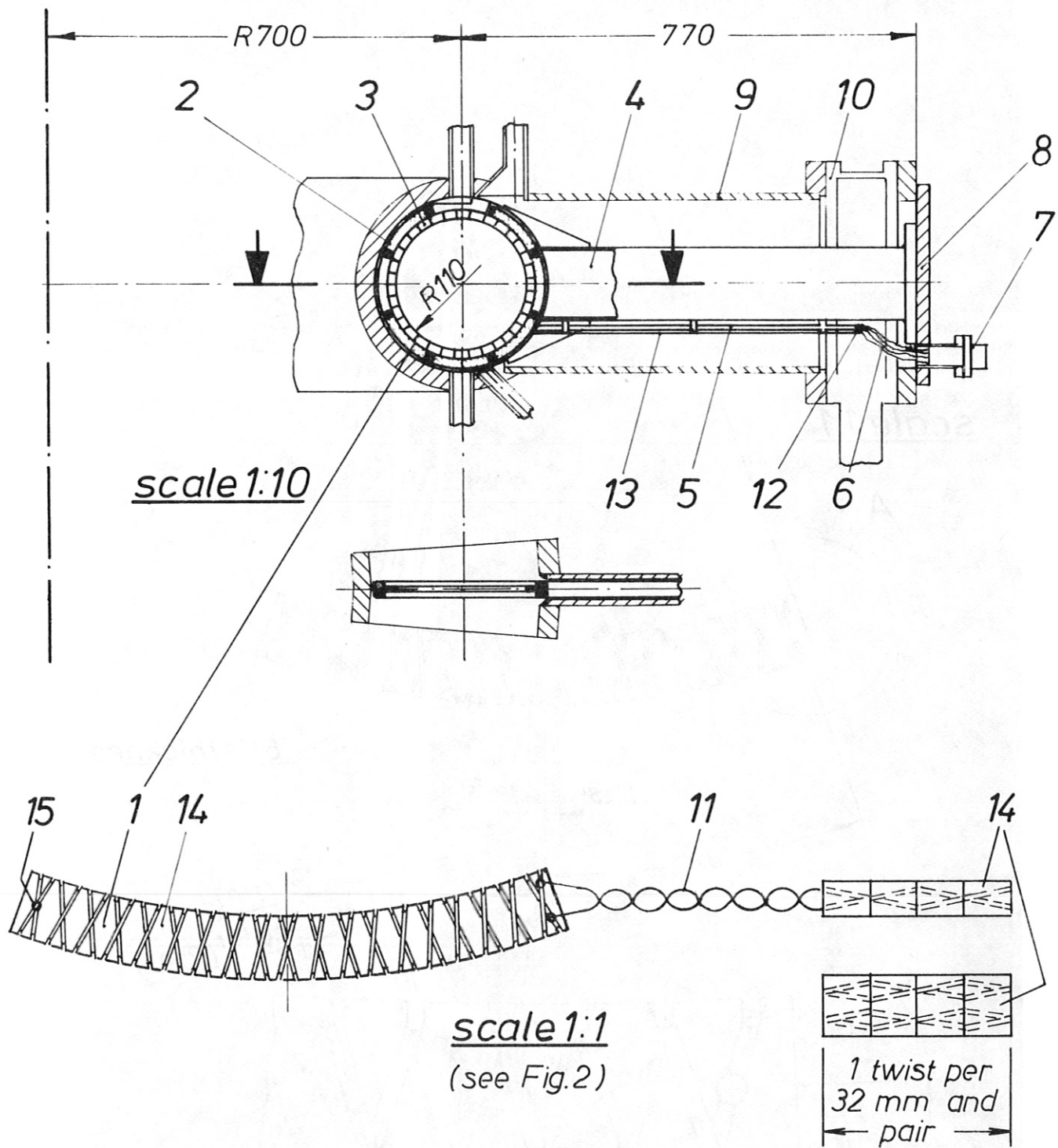

- 1. magnetic probes, 7 pieces
- 2. mounting plate
- 3. molybdenum segment
- 4. limiter housing
- 5. ceramic insulated titanium wire
- 6. kapton insulated wire $\phi 0,25\text{mm}$
- 7. feed through

- 8. flange
- 9. diagnostic port
- 10. vacuum valve
- 11. titanium wire
- 12. welding spot (titanium wire and copper wire)
- 13. thermocouple
- 14. machinable glass ceramic
- 15. solder glass

scale 1:10

Fig. 2

scale 1:1

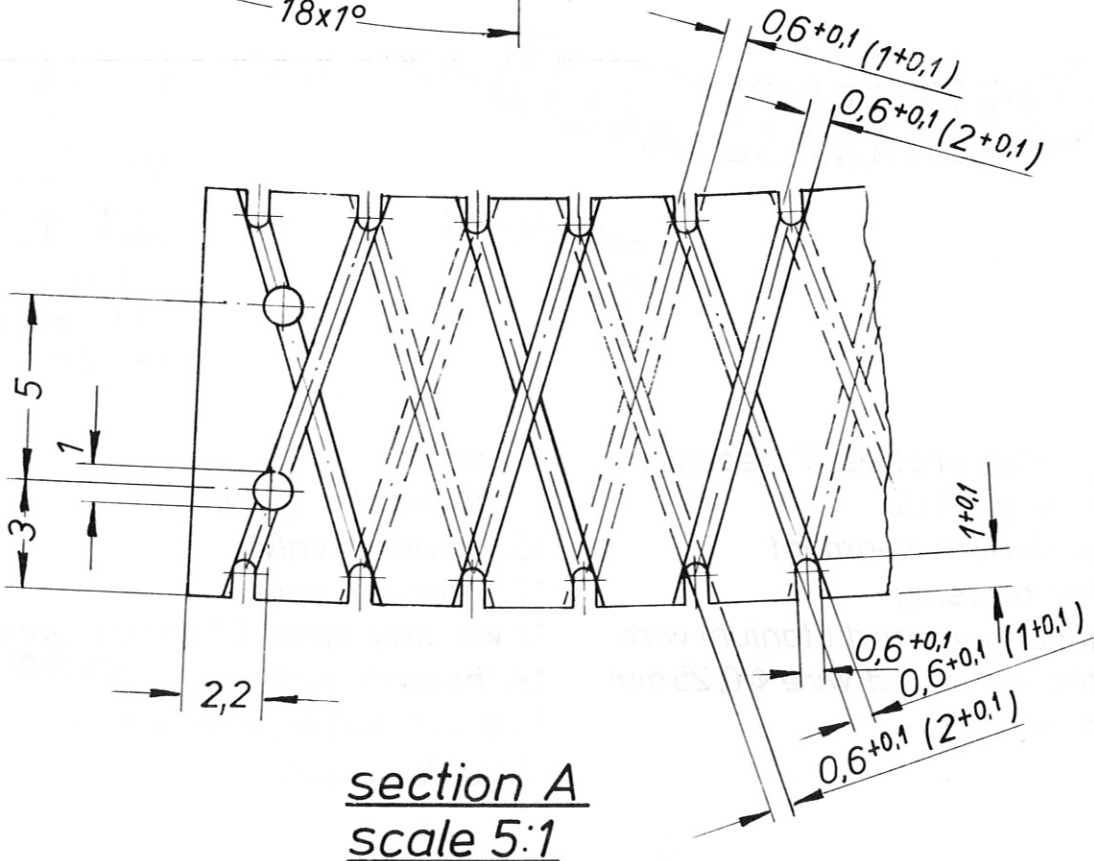
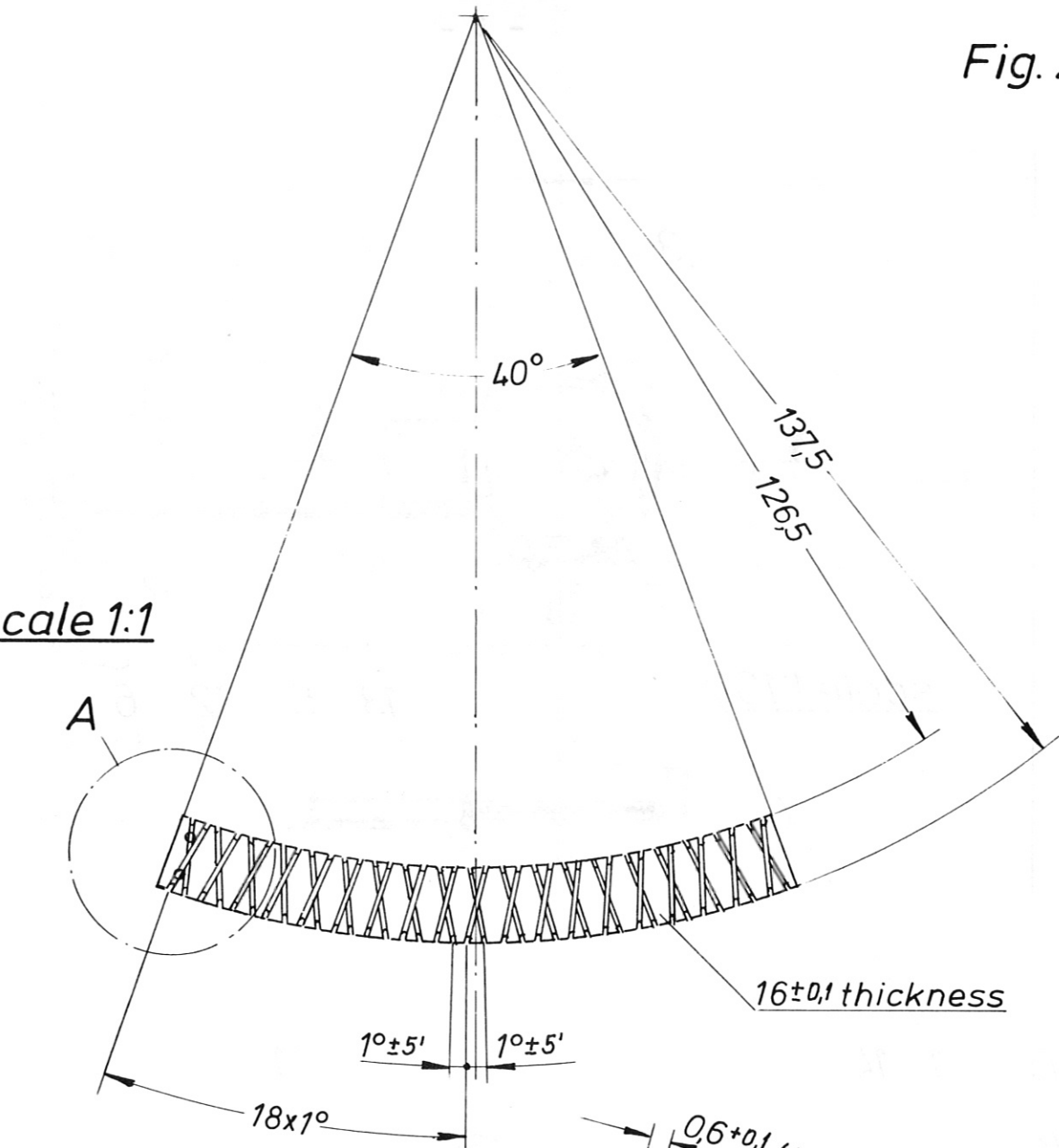

section A
scale 5:1

Fig. 3

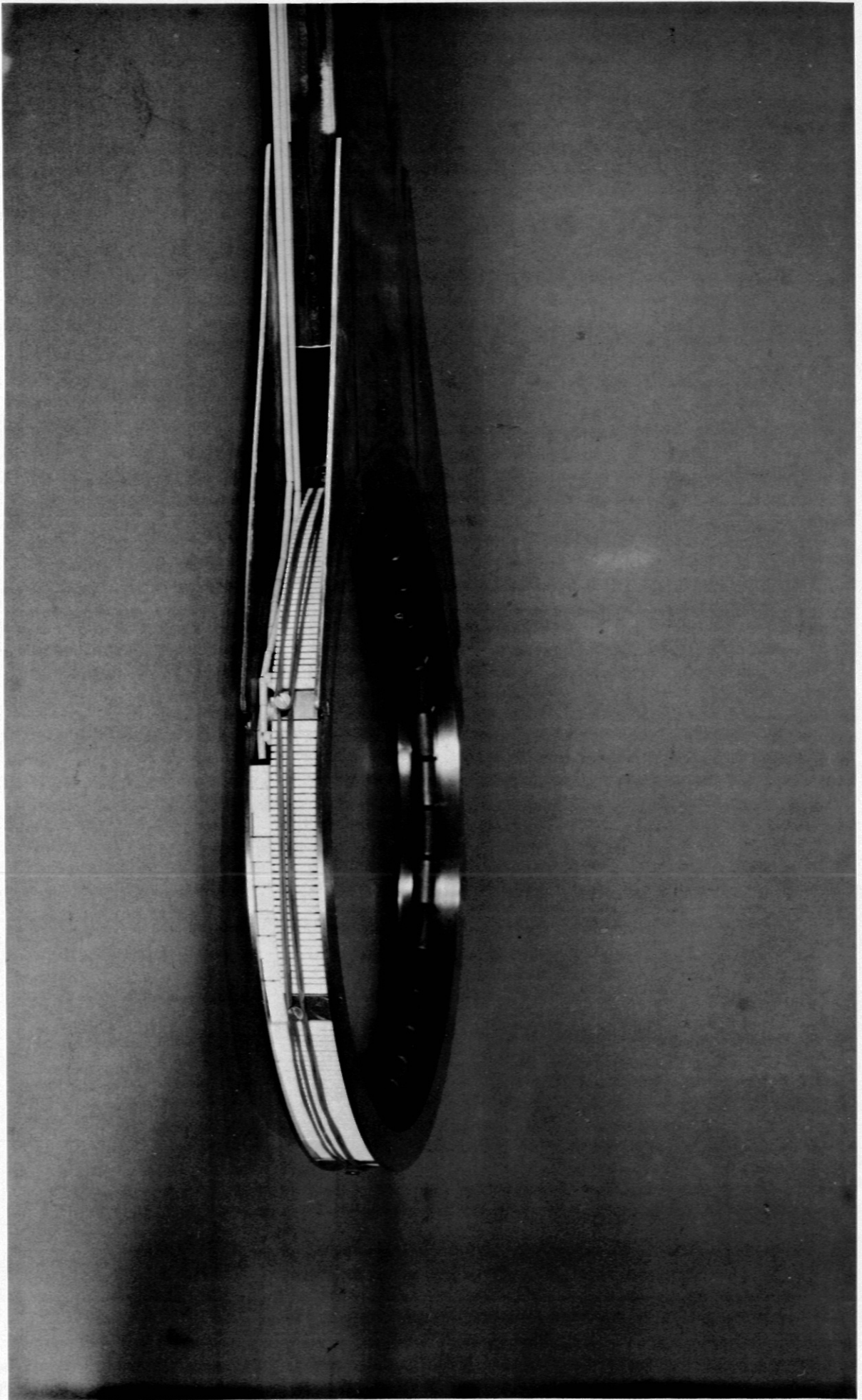

Fig. 4

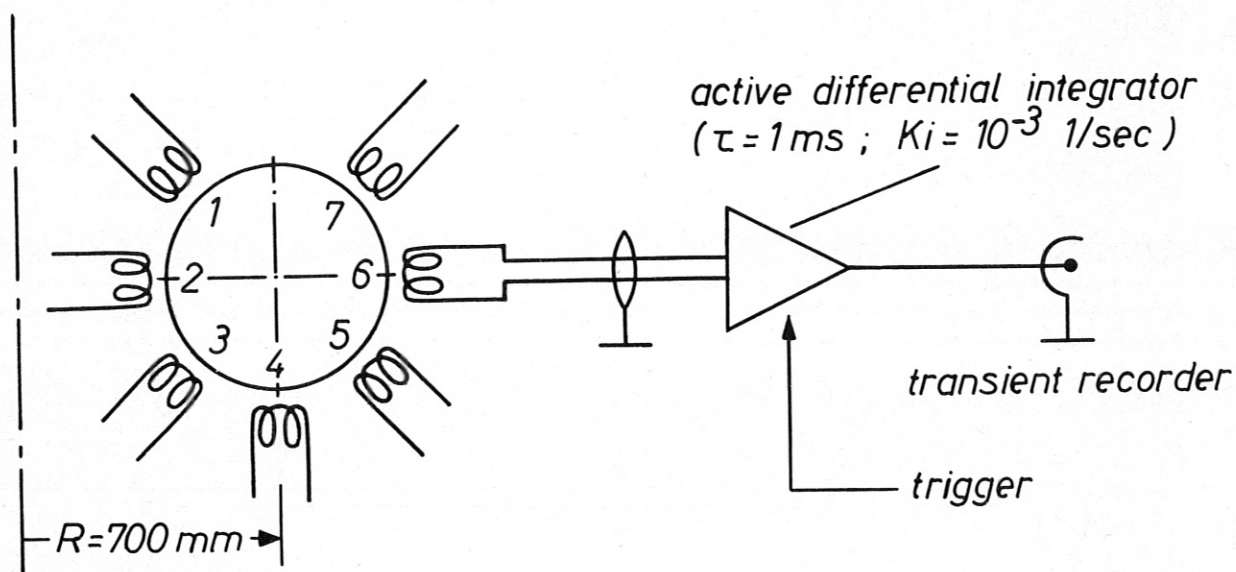
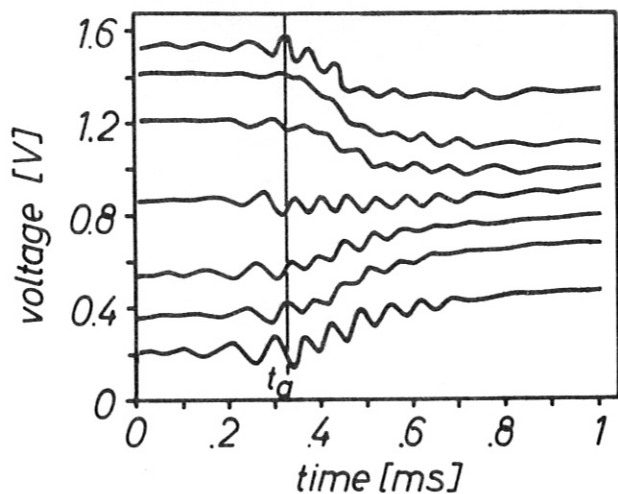

Fig. 5a



1 — N° of magnetic probes (poloidal)
 2
 3
 4
 5
 6
 7

shot N° 13994

amplitude of the magnetic probe
 signal versus time
 (transient recorder output)

Fig. 5b

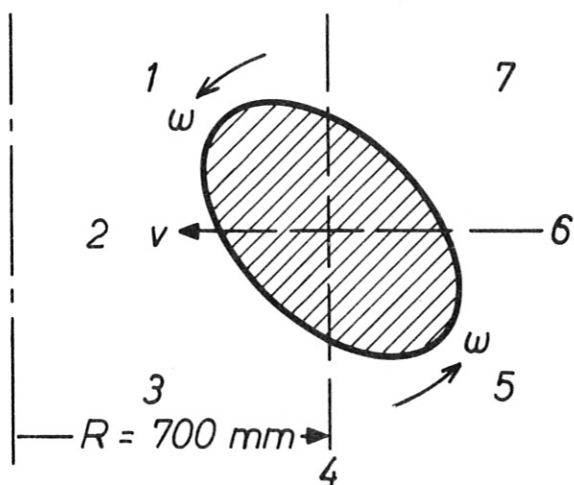

poloidal field rotation
 concerning only the rotation
 of the mode $m=2$
 shown for the time $t=t_a$
 (see Fig. 5a)

Fig. 6

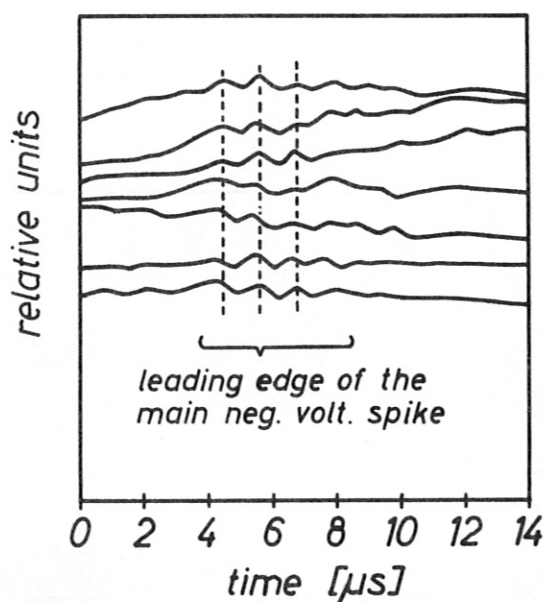

1 — N° of magnetic probes (poloidal)
 2
 3
 4
 5
 6
 7

shot N° 14017

$15 \mu s$ oscillogram of
 1 MHz oscillations during
 the leading edge of the
 main negative voltage
 spike