

CALORIMETER DESIGN-ASPECTS FOR NEUTRAL BEAM INJECTION ON W7-X

D. Holtum^a, M. Fröschle^a, B. Heinemann^a, T. Liebe^b, R. Nocentini^a,
R. Riedl^a, P. Rong^a, W. Schubert^b, A. Stäbler^a

^a Max-Planck-Institut für Plasmaphysik, EURATOM Association, Postfach 1533, D-85740 Garching, Germany

^b Fa. Xenos GmbH, Jugendstr. 2, D-81667 München, Germany

Neutral Beam Injection (NBI) is one of the heating systems for Wendelstein 7-X (W7-X). The beam power of the NBI is measured calorimetrically. Using the knowledge gained from ASDEX-Upgrade [1] operation, the complete calorimeter was re-designed. The design-aspects and the necessary improvements for operation on W7-X are described in this paper. The main aspects improved concern: i) the adapted slope of the winding drum at the lift, ii) the adjustable acceleration/deceleration ramp and integrated position sensors, iii) the improvements of panels in the body, iv) the accessibility for mounting panels, v) the water-distribution, and vi) the centering of the body on the support to fix and reproduce the measuring position. The manufacturing is in progress, installation will start in 2011 and the commissioning is scheduled for the end of 2014.

Keywords: Wendelstein 7-X, W7-X, neutral beam injection, NBI, calorimeter, design

1. Introduction

W7-X is a fusion plasma experiment (stellarator) under construction at Greifswald, Germany. One of the heating systems for W7-X, the NBI, will start with two injectors. Each injector is equipped with two ion sources (radio frequency type), later extended to four ion sources, which doubles the heating power. At the beginning the heating power of two injectors will be 7 MW (hydrogen) and 10 MW (deuterium). A calorimeter is mounted directly in front of the entrance of the torus duct (measuring position). Its functions are: i) to measure the heating power of the NBI, ii) to condition the ion sources (using the panels as a beam dump), iii) to align the beams properly in order to reduce losses at the walls of the duct. The beams of the four ion sources of an injector can be measured in parallel and separately in the four sections of the calorimeter. During normal operation of the NBI, the calorimeter is lifted up to 1.2 m at parking position.

The calorimeter is designed similarly to the calorimeter of the ASDEX-Upgrade injectors [2] at IPP in Garching, which are in operation since 1993. Several improvements for a better control and less maintenance have been considered at the design for the calorimeter of W7-X. They are described below.

2. Design description of the calorimeter

Fig. 1 shows the three assembly groups and gives the dimensions of the calorimeter. The assembly groups of the calorimeter are: the lifting device, the body and the support. The main parts of the lifting device are: the drive unit, the lifting bellows and the guiding mechanism. The main parts of the body are: the frame construction, the panels and the cooling water distribution system.

Describing the assembly process, at first the support is mounted inside the NBI-box. Then the body and the lift is installed as pre-assembled unit from the top of the box. The calorimeter flange seals the box from atmosphere. The calorimeter body, the support and the guiding pipes inside the lifting bellows operate at a pressure of 10^{-6} mbar. The lifting device works at atmosphere.

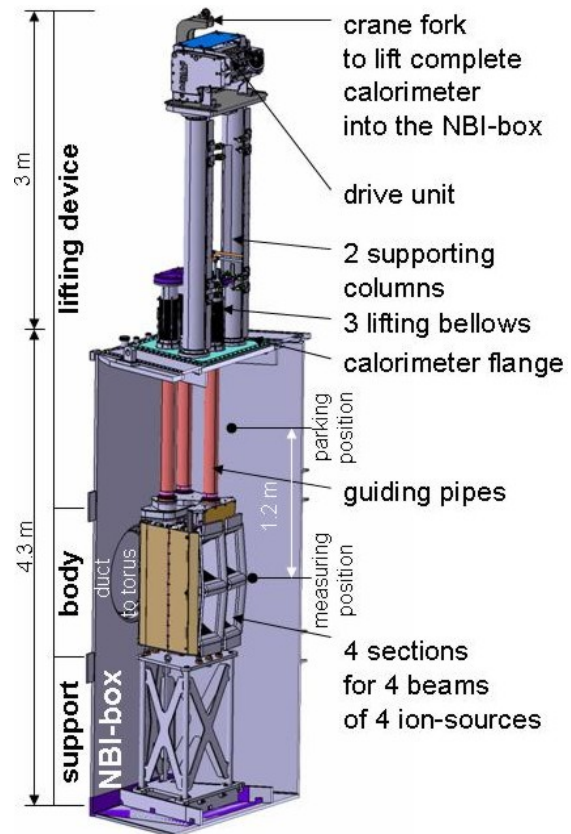

Fig. 1: Assembly groups of the calorimeter.

General design-aspects under vacuum conditions are considered. These are ventilation of blind threads and blind holes, avoiding cavities in the assembly and the welding seams. Attention is given to smooth surfaces with low outgassing by electrolytic polishing.

To minimize activation by fast neutrons, all materials should have as little Cobalt as possible (<2000 ppm). To reduce the magnetizability of the materials the relative permeability must be less than 1.01. The mass of Cobalt and the relative permeability are to be documented.

The quality management of design, manufacturing and documentation is based on DIN EN ISO 9001.

2.1 The lifting device

The distance between the measuring and the parking position of the calorimeter is 1200 mm. The motion between the two positions is to be done about 40 times per day over 20 years. The standby time is about 16 hours per day, including the operating time about 2 hours per day.

The force to move the calorimeter is 27.2 kN, including the vacuum force on the surface of the lifting bellows of 7.5 kN. More than half of the mass is caused by the calorimeter body and one sixth by the cooling water.

This does not include friction forces, which are currently unknown. For safety, the total force was assumed to be 30 kN.

After a start ramp of 5 s the calorimeter will move at a constant velocity of 20 mm/s. The velocity to position the calorimeter in the last 5 s of the movement is less than 2 mm/s. These velocities and the ramps are adjustable. In case of an emergency stop, it should require less than 20 mm to stop motion.

Different types of drive units were examined for the lifting device. The gear belt drive is not acceptable because of the weakness of the belt at a given width. The flat belt and the chain drive cannot be positioned accurately enough. The spindle drive and the gear rod cannot be realized in the given time and the hydraulic drive is complex and expensive. The scissor table cannot be realized inside vacuum. Therefore it was decided to lift the calorimeter with a steel-rope and a crane-motor, and, furthermore, to control the positions and load-force.

2.1.1 The drive unit

The drive-unit is a lifting jack, not a crane. It is located in an area isolated by barriers. During operation the area near the calorimeter is not accessible. The components are standard crane parts. Fig 2 shows the mounted drive unit with the lifting interface.

While lifting, the point of load application is not allowed to move laterally. This is accomplished using two ropes, each with its own adapted rope drum, that are wound with opposite slopes. The rope drums provide the necessary angle of wrap for safety. A frequency converter controls the motor speed of the drive unit within a velocity of the calorimeter from 2 mm/s to 20

mm/s. The drive unit has an internal electrical brake and in addition a mechanical brake, which is able to hold without current 2.5 times the load. The position of the calorimeter is indicated absolutely. Its start- and end-position are restricted by electrical switches.

The gear of the drive unit should be oil-tight over the whole operating time. As an additional precaution an oil pan was also designed. Special EMV requirements inside the torus hall demands EN 61000-6-4 class A compliance.

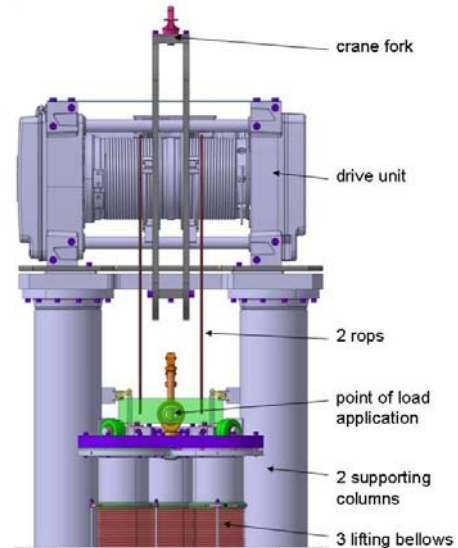

Fig. 2: Drive unit (currently out for tender).

The solution used at ASDEX-Upgrade is an electrical motor with only one rope, and a large rope drum, that has only two windings. The required guiding elements of the rope had to be replaced several times due to abrasion. Because the gear box is leaking oil, now an additional oil pan is installed to avoid pollution.

2.1.2 The lifting bellows

Bellows are used to separate the vacuum inside the box from atmospheric pressure outside. Two of them surround the cooling pipes for the calorimeter and the third one contains a pipe for sensor cables. The outer diameter of each pipe is 140 mm.

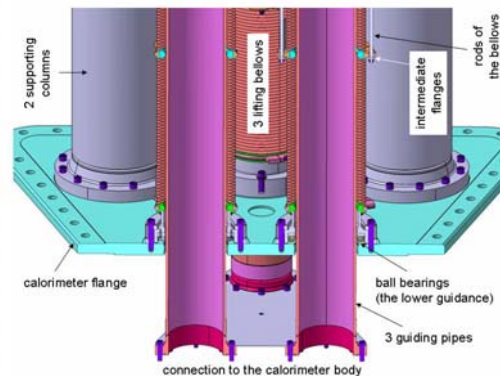

Fig. 3: Bellow flange with ball bearings for vertical guide.

Both sides of the bellows are equipped with flanges. Inside the lower flange, which is mounted onto the box, six ball bearings are mounted along the circumference with a distance of 0.25 mm to the pipe - to guide the pipes while lifting - see fig. 3. The bellows are operated vertically with a maximum allowable elongation of 1224 mm, of which 1.2 m is needed for operation. To avoid over-stretching of the upper membranes and too high compression of the lower membranes (due to the weight of the upper membranes), each bellows is split into four sub-units with flanges between them. The flanges at the sub-units are connected with rods, which limit the maximum tension as well as the maximum compression of the bellows.

The material of the bellows is stainless steel (1.4404, 316L) and the wall-thickness of the membrane is 0.2 mm. All bellows are certified for a leak rate of 10^{-9} mbar-l/s with a guaranteed lifetime of 10000 cycles.

The operation of similar bellows at ASDEX-Upgrade failed only once because the pipes contacted the intermediate flanges of the bellows, which produced small abrasion particles causing a leak in the bellows. To avoid this at W7-X the inner diameter of the intermediate flanges were increased and the tipping angle of the guiding pipes inside the bellows was restricted to 1.2° by guiding all lifted parts more precisely.

2.1.3 The guiding mechanism

To reproduce the parking and measuring position of the calorimeter, the three guiding pipes are controlled at two points. One guiding point is stationary at the level of the box-flange, as described above. The other guiding point is at the upper end of the bellows, which is the point of load application, see fig. 4. Four polyamide heavy duty rollers with an outer diameter of 80 mm move up and down on the two supporting columns. The distance between rollers and columns is fixed, but adjustable with fine thread screws.

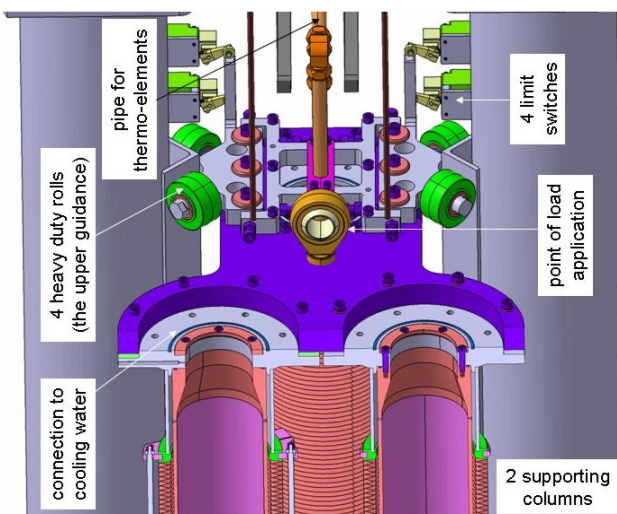

Fig. 4: Upper guiding point with heavy duty rolls.

At ASDEX-Upgrade the lower ball bearings are inside the vacuum chamber, restricting the accessibility for maintenance. Whereas at W7-X they are accessible

from outside the vacuum. Furthermore the fixation of the heavy duty rolls is modified from a spring loaded to a fixed design.

2.2 The body with the panels

The calorimeter body (see fig 5) was designed to fix the panels in a position to measure the beam power. The cooling pipes, bellows and thermo sensors are integrated. Bellows are between the panels and the cooling pipes and compensate thermal expansion of the panels. In addition, each panel has only one fixed point with the body. The distribution of the water is done in such a way that the resultant forces are symmetrical for the frame.

Based on the experience with ASDEX-Upgrade, the body is vertically subdivided into two modules, as this improves the accessibility for mounting and maintenance. The panels can be removed easily by dismantling the shelter sheets at both sides.

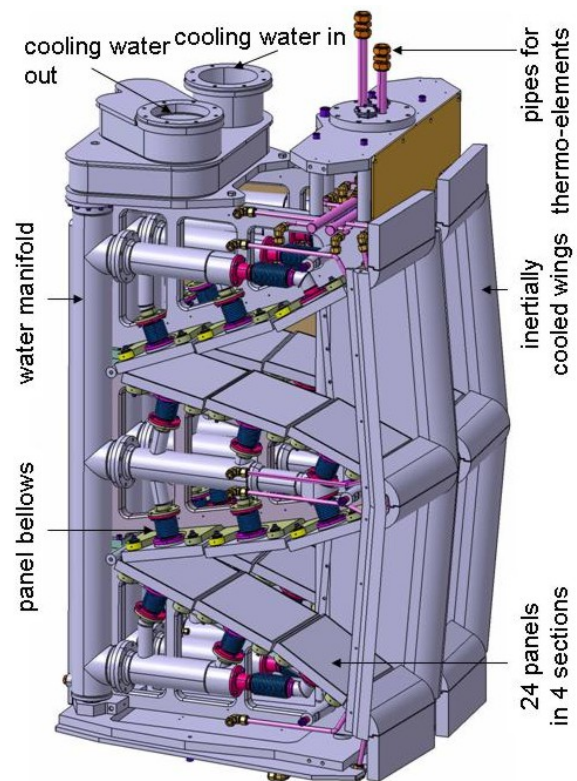

Fig. 5: The calorimeter body (cross section through the left module).

The panels are the main part of the body. Their function is to measure the power of the beam calorimetrically. The 24 panels are arranged in four sections, each section for one ion source. The panels are inclined relatively to the beam axis to reduce the heat load to acceptable values. The opening angle of a section is between 33° and 54° , which reduces the heat load per area of the panels to less than one third and less than a half respectively. The allowable power density for steady state operation on the surface of the panels is 25 MW/m^2 resulting in a maximum surface temperature of 377°C .

A panel is 250 mm x 200 mm and 24 mm thick, see fig. 6. 18 fine structured cooling channels are close to the heated surface and connected to a manifold at both ends.

The water inlet pressure is 16 bar, the pressure drop inside the panel is 6 bar, the flow is 3 l/s and the measured temperature difference is expected to be up to 80 °C. The material is CuCrZr, with the exception of the water connections, which made of nickel (NI270) and stainless steel (316L). The same panels are used on ASDEX-Upgrade [3-6], but the manufacturing process has been changed in order to benefit from better material properties and to increase lifetime.

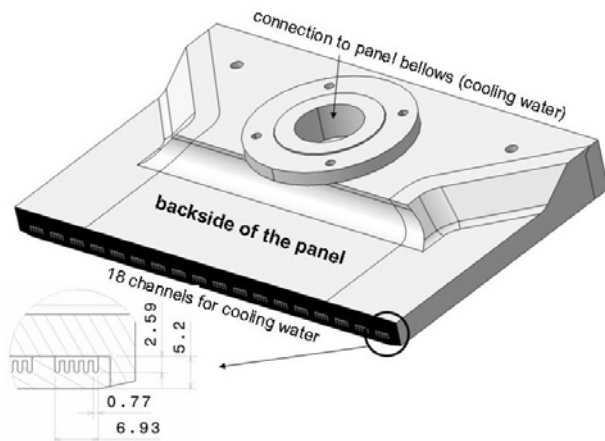

Fig. 6: Half of a panel.

2.3 The support

The support of the calorimeter (see fig. 7) is bolted to the bottom of the NBI-box. It defines the measuring position and supports the quasi-static load of all moving parts (including the vacuum forces) of 30 kN. Thermal expansion is accounted for between -40 to +40°C, due to the influence of the nearby cryo-pump.

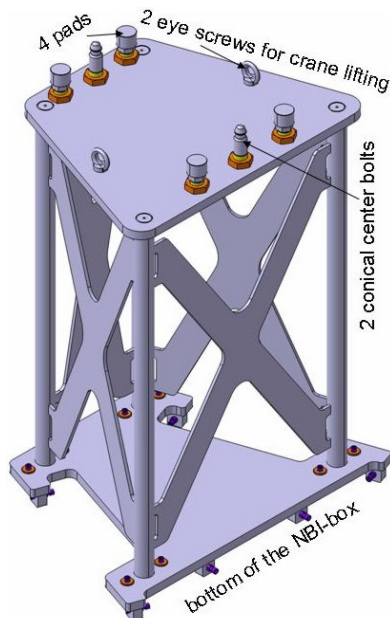

Fig. 7: The support with center bolts and pads.

The frame of the support is a simple steel construction made of stainless steel (1.4301) with four rods, each with an allowable static buckling load of 400 kN. It must sustain a possible dynamic load of 225 kN, if the deceleration ramp fails. Two conical center bolts enable it to catch and center the calorimeter body within

a radius of 15 mm. They are made of stainless steel (1.4980), which allows a surface hardening with the depth of 33 μm (Kolsterising). The four pads made of stainless steel (1.4311) have to carry 30 kN. They are planar and have a diameter of 60 mm. The mass of the support is 360 kg.

The support is similar to the one used at ASDEX-Upgrade. There are three improvements compared to the system at ASDEX-Upgrade: The capture radius of the center bolts is enlarged, the pads are continuously adjustable, and the base of the calorimeter body is reinforced at the points of supporting by the pads.

3. Control and data management

The complete NBI is controlled from a separate room about 150 m away from the experiment hall. In addition it is possible to operate the calorimeter lifting system locally on the top of the box. In order to avoid a possible control signal conflict, it is mandatory to select either the control room or the local control with a one key switch.

All data are transmitted by optical fibers. The control is done by different field busses, mainly profi bus.

4. Status of manufacturing and prospects

The manufacturing of all components is presently ongoing. Many parts are produced in-house. Large components and complex parts like the panels were given to external manufactures. The drive unit for lifting, including the load fixation, has been bought as a unit. The calorimeter support and most parts of the body have already been manufactured. The panels are long lasting items and still under construction.

The assembly of two calorimeters for the NBI including local control is planned to be finished in spring 2012. The installation in the NBI-Box is planned in 2013. This will be done in the torus-hall in the final position of the NBI-Boxes. Commissioning is scheduled at the end of 2014.

5. Conclusion

Based on the experience of the operation at ASDEX-Upgrade the calorimeter for the NBI at the W7-X is completely redesigned. Main aspects are: a lot of improvements at the design, new functions in controlling and a simplified assembly. Some enhanced material properties and manufacturing methods are taken into consideration.

References

- [1] A. Stabler, et al., Fusion Technology 1988, 620-624.
- [2] B. Heinemann, et al., Fusion Technology 1992, 524-528.
- [3] R. Kreutz, et al., Proceedings Jahrestagung Kerntechnik Munchen 1985, 769-772.
- [4] K. Iversen, et al., Proceedings Jahrestagung Kerntechnik Munchen 1985, 773-776.
- [5] J.-H. Feist, et al., Proceedings Jahrestagung Kerntechnik Munchen 1985, 777-780.
- [6] J.-H. Feist, et al., Fusion Technology 1992, 486-490.