

EXAMINING NOVEL ROLES FOR THE I κ B KINASE IN COORDINATING THE CELLULAR RESPONSE TO METABOLIC STRESS

William C. Comb

A dissertation submitted to the faculty of the University of North Carolina at Chapel Hill in partial fulfillment of the requirements for the degree of Doctor of Philosophy in the Curriculum in Genetics & Molecular Biology

Chapel Hill
2011

Approved By:

Albert S. Baldwin Ph.D.

Mohanish Deshmukh Ph.D.

Terry Magnuson Ph.D.

Bill Marzluff Ph.D.

Yue Xiong Ph.D.

ABSTRACT

WILLIAM C. COMB: Novel roles for I κ B Kinase (IKK) in response to metabolic stress
(Under the direction of Dr. Albert S. Baldwin)

The induction of mammalian autophagy, a conserved cellular bulk-degradation process, was recently shown to require Inhibitor of κ B (I κ B) Kinase (IKK), the upstream regulator of nuclear factor (NF)- κ B transcription factors. In response to cell stress IKK has been exclusively studied for its ability to activate NF- κ B-dependent pro-inflammatory gene expression; surprisingly this activity is not required for starvation-induced autophagy and the mechanism by which IKK promotes this activity are largely unknown. Here we investigate the role of IKK/NF- κ B pathway in response to both acute and prolonged nutrient deprivation, a classic autophagy- and novel NF- κ B-inducing stimulus. We demonstrate that classic IKK-dependent NF- κ B activation and gene expression occurs in response to cell starvation. Independently, IKK controls expression of genes necessary for autophagic machinery in response to prolonged starvation. The work presented in Chapter 2 will demonstrate that IKK is important molecule upstream of changes in gene expression induced by cellular starvation. IKK activity in response to acute starvation is also explored within and we identify that this kinase is important for transducing signals that inhibit growth and metabolic pathways. We find that IKK is required for inhibition of growth factor-dependent signaling through phosphorylation of the novel IKK substrate Phosphoinositide 3-Kinase (PI3K). The work outlined in Chapter 3 identifies a novel cross-talk mechanism between growth and stress responsive signal transduction pathways important for coordinating the cellular response to nutrient availability. In summary, the following manuscript will identify two novel functions for the IKK complex in regulating nutrient sensitive pathways, establishing the critical role of this kinase in cellular adaptation to metabolic stress.

ACKNOWLEDGEMENTS

I am indebted to a number of people that have aided my progress along the way, academically, professionally, and personally. Without the help of those listed below and a great deal more that I was unable to mention specifically these last few years would have been infinitely more difficult.

Most importantly, to my mentor, Al Baldwin: thank you for the support and the intellectual freedom over these past four years. Thank you for helping keep my energy and enthusiasm in check and for showing me that redeeming qualities can always be found even when the first glance fails to recognize any.

To my thesis committee for their guidance, criticisms, and thoughtful discussions. I am grateful for the support of Dr. Mohanish Deshmukh, Dr. Terry Magnuson, Dr. Bill Marzluff, and Dr. Yue Xiong.

I am thankful for all members of the Baldwin Lab past and present for great discussions, patience, and friday happy hours. My thanks to Jessica Hutti for her support and trouble on the p85 project, at least somebody understands what a nightmare that project was. I am also especially grateful for Dr. Raquel Sitcheran, Dr. Brian Bednarski, Dr. Evan Merkhofer, Sarah Stein, Amanda Rinkenbaugh and Patty Cogswell for being great friends as well as great colleagues.

To past mentors for helping get me here: Dr. Michael Comb, Dr. Tom Gilmore, Dr. Randy Wetzel, Dr. James Weiler, Andreas Nelsbach, and Chris Salvadore.

To the IBMS program that admitted me to UNC for graduate study. Most importantly, Dr. Sharon Milgram for the opportunity. And to my classmates for first year group, classes, discussions - you made it much easier. Thanks to UNC GMB for years 2-6, especially Dr. Bob Duronio and Sausyty Hermreck, they made it easier than it had to be.

To all of the friends I've made at UNC along the way, you know who you are. We worked hard and we played hard.

To my parents, for showing me the importance of an education. For never limiting my chances or opportunities and for the personal sacrifice, I know you made many. Thanks for your unconditional love and support.

Finally, to my bride to be, the most patient woman in the world. Thanks for tolerating late nights, skipped meals, science time, and everything in between. We all know how lost I'd be without you, thank you for being there for me.

Dedicated to the memory of Susan Connors.

TABLE OF CONTENTS

List of Figures	vi
List of Abbreviations	viii
Chapter	
I. INTRODUCTION	
1.1 Nuclear Factor- κ B (NF- κ B).....	2
1.2 I κ B Kinases (IKKs)	3
1.3 Autophagy.....	6
1.4 IKK/NF- κ B and Autophagy	7
1.5 PI 3-Kinase (PI3K)	10
1.6 Akt.....	11
1.7 Mammalian Target of Rapamycin	12
1.8 PI3K/Akt/mTOR Signaling	13
1.9 Conclusions.....	15
REFERENCES.....	22
II. IKK-DEPENDENT, NF- κ B-INDEPENDENT CONTROL OF AUTOPHAGIC GENE EXPRESSION	
2.1 Abstract.....	28
2.2 Introduction.....	29
2.3 Results and Discussion	31
2.4 Experimental Procedures	39

REFERENCES	46
III. IKK-DEPENDENT PHOSPHORYLATION OF p85 α PROMOTES PI3K FEEDBACK INHIBITION IN RESPONSE TO NUTRIENT DEPRIVATION	
3.1 Abstract	50
3.2 Introduction	51
3.3 Results	55
3.4 Discussion	63
3.5 Experimental Procedures	69
REFERENCES	79
IV. CONCLUSIONS	
4.1 Summary	83
4.2 Hypothesis: IKK Compensates for Loss of mTORC1- Dependent PI3K Feedback in the Absence of Amino Acids	88
4.3 Conclusions	91
REFERENCES	103

LIST OF FIGURES

1.1	Domain organization of NF- κ B and I κ B family members	17
1.2	Pathways of NF- κ B activation	18
1.3	Domain organization of canonical IKK subunits.....	19
1.4	Domain organization of Class1A PI3K subunits	20
1.5	Signaling through PI3K/Akt/mTOR axis in higher eukaryotes	21
2.1	IKK/NF- κ B signaling is activated by nutritional stress.....	41
2.2	IKK is required for basal and starvation-induced expression of pro-autophagic genes	42
2.3	Basal and starvation-induced autophagic gene expression is NF- κ B-dependent.....	43
2.S1	Starvation induces pro-autophagic gene expression	44
2.S2	p65 is not required for starvation-induced <i>NFKB1A</i> expression.....	45
3.1	IKK is required for starvation-induced feedback inhibition of Akt.....	73
3.2	PI3K regulatory subunit p85 α is a putative IKK substrate	74
3.3	IKK-mediate p85 α Ser690 phosphorylation <i>in vitro</i> and <i>in vivo</i>	75
3.4	IKK-dependent Ser690 phosphorylation occurs <i>in vivo</i> in response to whole body fasting and correlates with PI3K/Akt feedback	76
3.5	Ser690 is required for IKK-mediated and starvation-induced PI3K feedback inhibition.....	77
3.6	Ser690 phosphorylation disrupts p85-phospho-tyrosine binding	78
4.1	Model for starvation-induced IKK-dependent control of gene expression	96
4.2	Model for starvation-induced IKK activity controls PI3K feedback inhibition through p85 subunit phosphorylation.....	97
4.3	Amino acid withdrawal is necessary and sufficient for IKK-dependent p85 phosphorylation.....	98

4.4	IKK controls PI3K feedback in response to amino acid deprivation.....	99
4.5	Compensatory IKK-dependent feedback inhibition of PI3K in the absence of leucine - implications for loss of mTORC1 feedback	100
4.6	Feedback inhibition of GF-dependent PI3K activity in the presence and absence of leucine	101
4.7	Model for IKK control in physiology and pathology	102

LIST OF ABBREVIATIONS

AA	Amino acid
Akt	v-akt murine thymoma viral oncogene homolog
Atg	Autophagy related gene
ATM	Ataxia telangiectasia mutated
BAFF	B-cell activating factor
BCAA	Branched chain amino acid
cIAP	Cellular inhibitor of apoptosis protein
EMSA	Electrophoretic mobility shift assay
GF	Growth factor
GST	Glutathione-S-Transferase
HBSS	Hank's Balanced Salt Solution
HM	Hydrophobic motif
IBD	Inflammatory bowel disease
IKK	I κ B Kinase
IL-1	Interleukin 1
IR	Insulin Receptor
IRS	Insulin Receptor Substrate
I κ B	Inhibitor of κ B
LPS	lipopolysaccharide
mEF	Mouse embryonic fibroblast
NEMO	NF- κ B essential modulator
NF- κ B	Nuclear factor kappa light chain enhance activated in B cells
NIK	NF- κ B inducing kinase
NLS	Nuclear localization sequence
PH	Pleckstrin homology
PI3K	Phosphoinositol 3-kinase
PIKK	Phosphoinositide 3-kinase related kinase
PIP2	Phosphatidylinositol-4,5,-bisphosphate
PIP3	phosphatidylinositol-3,4,5,-triphosphate
PMA	Phorbol 12-myristate 13-acetate
PTEN	Phosphatase and tensin homology
RANKL	Receptor activator for NF- κ B ligand
RHD	Rel homology domain
RTK	Receptor tyrosine kinase
SH2	Src Homology 2
SU2C	Stand Up 2 Cancer

TAD	Transcriptional activation domain
TBK1	TANK-binding kinase 1
TCR	T-cell receptor
TLR	Toll-like receptor
TNF α	Tumor necrosis factor α
TOR	Target of Rapamycin
TRAFs	TNF receptor-associated factors
Ub	Ubiquitin

Chapter One

INTRODUCTION

1.1 Nuclear Factor- κ B

The eukaryotic transcription factor family NF- κ B (nuclear factor kappa-light chain-enhancer of activated B cells) consists of five subunits (p65/RelA, RelB, c-Rel, p100/52, and p105/p50) characterized by an amino-terminal Rel Homology Domain (RHD) which confers the ability to form hetero- and homo-dimeric complexes and bind consensus κ B elements in DNA. In resting/unstimulated cells NF- κ B remains sequestered from the nucleus by the I κ B family of inhibitory proteins which bind the RHD through a series of ankyrin repeats and mask the C-terminal NLS (Figure 1.1) (Hayden & Ghosh 2004). Signal-dependent phosphorylation of critical serines by I κ B Kinases mark I κ B proteins for polyubiquitination and proteasome-dependent degradation; thus liberating NF- κ B to translocate to the nucleus, bind DNA, regulate the expression of a target genes that promote cell survival in response to myriad cell stresses (Gilmore 2006).

The list of stresses and stimuli that distinctly activate NF- κ B is ever-growing, but discussion of NF- κ B activation often focuses on two pathways in particular for general classification (Figure 1.2) (For comprehensive and current list see NF- κ B.org, Gilmore TD). The canonical pathway, comprised of p65/p50 subunit heterodimers (though often makes use of c-Rel subunit), is activated by cytokines like TNF α or agonists of TLR signaling such as LPS, and generally thought to be controlled by the IKK β subunit (see below). The non-canonical pathway is controlled by the IKK α subunit, activated in lymphoid tissue by a subset of TNF-Receptor family member ligands such as BAFF and RANK, and leads to activation of RelB/p52 NF- κ B subunits (Bonizzi et al. 2004). In reality however, cellular

control of NF- κ B signaling is much more complex, and occurs through a number of pathways and mechanisms.

Feedback control of NF- κ B is an essential hallmark of pathway activation. NF- κ B induces the transcription of I κ B genes, which results in binding and nuclear export of NF- κ B complexes; hence sustained stimulation results in a characteristic cyclical activation of target genes due to the degradation/resynthesis cycles of I κ B (Hoffmann et al. 2006). Further levels of feedback occur through regulation of post-translational modification of components necessary for activation of the IKK complex. For example, control of NF- κ B is heavily mediated by ubiquitin-editing enzymes which promote assembly and disassembly of scaffolding complexes that activate IKK (Skaug et al. 2009). The importance of restricting duration and amplitude of signaling is underscored by fact that chronic inflammation driven by constitutive activation of NF- κ B is involved in pathogenesis of a number of diseases including, but not limited to, cancer, IBD, asthma, and metabolic disorders (Bassères & Baldwin 2006; Baker et al. 2011; Atreya et al. 2008). Therefore, understanding the molecular events initiated by NF- κ B-inducing stimuli, and those events that become mis-regulated in disease, is of utmost importance if we are to treat the underlying causes of such disorders.

1.2 I κ B Kinases

IKK α and IKK β are two highly similar serine/threonine kinases that are able to phosphorylate I κ B proteins in response to NF- κ B inducing stimuli. Together with a regulatory subunit NEMO, they comprise a high molecular weight protein kinase complex herein referred to as IKK (Figure 1.3) (Häcker & Karin 2006). The IKK family of kinases

also include IKK ϵ and TBK1 which coordinate the interferon response to viral infection, but will not be discussed further (Fitzgerald et al. 2003). IKK catalytic subunits play both overlapping and non-redundant roles as evidenced by the fact that knocking out either of the IKK catalytic subunits from the mouse results in lethality from distinct phenotypes, while animals lacking both subunits die at an earlier stage of embryogenesis presumably from a defect not observed in single KOs masked by redundant functions (Scheidereit 2006).

As mentioned above, the classification of IKK/NF- κ B activation into two general pathways, each requiring a distinct IKK subunit, is often an over-simplification. Signal-dependent activation of NF- κ B programs are often cell type- and stimulus-specific each with different requirements for IKK subunits. Activation of IKK has been observed in response to just about all types of cell stress, and the molecular events regulating IKK activation are surely distinct. One example of this phenomena is observed by comparing examples of IKK α -dependent NF- κ B activation. As alluded to above, IKK α regulates activation of the non-canonical NF- κ B pathway through a NIK-dependent but NEMO-independent manner (Gloire et al. 2007). On the other hand, canonical NF- κ B activity in response to IL-1 stimulation occurs in an IKK α - and NEMO-dependent manner (Solt et al. 2007), therefore it is insufficient to describe such a complex and highly utilized pathway with two generalized models of activation. As mentioned, one commonality from a number of examples of signal-dependent activation of IKK is the role for ubiquitin editing enzymes. K63 linked poly-ubiquitination promotes nucleation of large signaling complexes necessary for IKK activity, in part through the propensity of NEMO to bind ubiquitin chains as well as be ubiquitinated itself (Adhikari et al. 2007). Some level of specificity is likely achieved through use of

specific TRAF family members which are critical activators of NF- κ B activity and promote formation of these large signaling scaffolds (Kawai & Akira 2007).

IKK subunits are named for their ability to phosphorylate I κ B proteins, but these are not the only IKK substrates in cells. A few studies have been undertaken to identify and characterize IKK-dependent phosphorylation events in order to fully appreciate the importance of IKK activity in cells. The identification of the optimal IKK β substrate phosphorylation motif was an important step toward understanding the breadth of IKK substratome in cells. Using an *in vitro* peptide library approach to determine substrate specificity, the deubiquitinating enzyme A20 was identified as a novel IKK substrate. IKK β -mediated phosphorylation promoted A20 activity and removal of K63-linked Ub chains; this mechanism promotes feedback inhibition of NF- κ B following TNF α -stimulation (Hutti et al. 2007). Given the cardinal role of IKK in activating NF- κ B it is not surprising that the vast majority of substrates identified have similar roles involved in fine-tuning the duration and amplitude of NF- κ B activation. A few NF- κ B-independent IKK substrates have been described but these have mostly been in the context of disease models and the role of these phosphorylation events in response to physiological stimuli are still not understood (Hu et al. 2004; Lee et al. 2007).

Recently, an unbiased small molecule screen identified an NF- κ B-independent function for the IKK complex in promoting the cellular catabolic process autophagy in response to cellular stress (Criollo et al. 2009). These findings are the first to demonstrate a bona fide role for the canonical IKK complex in regulating biological processes independent

of NF- κ B activity, but the authors were unable to demonstrate the mechanism by which this activity occurs.

1.3 Autophagy

Macroautophagy (herein referred to as autophagy) is an ancient cell survival mechanism that arose in single-celled eukaryotes to respond to nutritional cues and maintain energy homeostasis (Klionsky 2005). Literally meaning “to eat oneself,” autophagy occurs at basal levels in all cells as a cellular housekeeping mechanism, facilitating degradation and turnover of long-lived macromolecules and organelles, while also preventing buildup of damaged cytoplasmic components or potentially toxic molecules. Autophagy can be upregulated as a cell survival mechanism in response to hypoxia, metabolic stress, DNA damage, and other cellular insults. A well characterized example of this is the cell’s response to nutrient deprivation. When a cell’s local nutrient availability is insufficient, autophagy is induced as an energy conservation mechanism promoting such activities as breakdown of long-lived proteins into constituent amino acids which allows the cell to continue to sustain new protein synthesis (Klionsky 2000). This recycling mechanism serves as a stress response allowing cells to maintain a minimal amount of metabolism, in an environment that would not otherwise permit such activity, until conditions are restored. Notably, autophagy is required for development and animals lacking genes required for autophagy die prior to, or soon after, birth (Mizushima & Levine 2010). Importantly, in higher eukaryotes misregulated autophagy is associated with a number disease states including neurodegeneration, cancer, aging, and heart disease (Levine & Kroemer 2008). Therefore,

understanding the biology of this process is essential to understanding proper development and the pathogenesis of many important diseases.

Much of our understanding of the molecular events that regulate autophagy were discovered using classical genetic screens in yeast which identified dozens of ATG family proteins involved in autophagosome formation and trafficking (Yorimitsu & Klionsky 2005). The induction of autophagy is marked by the *de novo* formation of double-membraned organelles called autophagosomes which engulf molecules targeted for degradation. An autophagosome undergoes maturation when it docks and fuses with the lysosome to form an autolysosome, which contains the enzymes and acidic environment necessary for catabolism of engulfed contents.

In all eukaryotic cells nutrients, energy, and stress are sensed directly by the the large serine/threonine kinase complex called Target of Rapamycin (TOR) which is an important negative regulator of autophagy (see below) (Raught et al. 2001). Inhibition of TOR, by treating cells with the naturally occurring antibiotic Rapamycin or by cellular starvation, results in rapid activation of autophagy and inhibition of cellular metabolism. In higher eukaryotes mammalian (m)TOR also integrates oxygen sensing and growth factors through upstream inputs to control an even more diverse set of catabolic and anabolic processes(Sengupta et al. 2010). Unlike yeast, a complete understanding of the regulation of autophagy in mammalian cells has proven to be quite challenging as a result of complexity and crosstalk between networks involved in signal integration.

1.4 IKK/NF- κ B and Autophagy

Autophagy and NF- κ B both provide the cell with rapid ways to induce survival programs in response to cell stress. In fact, many stresses activate both autophagy and NF- κ B (eg: TLR signaling) but whether these are co-coordinated or independent pathways remains poorly understood (Delgado et al. 2008). The significance of NF- κ B activation in controlling inflammatory and immune signaling has been well understood, and more recently autophagy has become appreciated for its role in promoting these activities as well, but the connection between each of these pathways remains elusive and controversial (Levine et al. 2011).

Previous studies aimed at addressing this question have demonstrated both positive and negative control of autophagy by NF- κ B. For example, in Ewing Sarcoma Cells, TNF α - induced NF- κ B inhibits TNF α -stimulated autophagy (Djavaheri-Mergny et al. 2006). This result is consistent with the role of NF- κ B inhibiting apoptosis in response to TNF α , because loss of NF- κ B results in cell death through stimulation of the extrinsic pathway of apoptosis in the absence of NF- κ B activated anti-apoptotic genes like Bcl2 (Dutta et al. 2006). Of note, the interplay between autophagy and apoptosis is a field of active investigation. Anti-apoptotic BH3-only proteins like Bcl-2 have important roles in coordinating VPS34 the lipid kinase that regulates autophagosome formation (Pattingre et al. 2005). Conversely, NF- κ B activates autophagy in response to TCR activation induced by PMA-ionomycin or anti-CD3 (Copetti et al. 2009). Interestingly, both of these studies identified NF- κ B transcriptional control of the essential autophagy gene *BECN1* as an important aspect of the mechanism by which NF- κ B controls autophagy. Inhibition of NF- κ B activity in Ewing Sarcoma cells

results in TNF α -induced *BECNI* expression, suggesting that NF- κ B represses *BECNI* expression. On the other hand, NF- κ B activity in T-cells promotes *BECNI* expression; in each case, increased Beclin-1 expression results in up-regulated autophagy (Djavaheri-Mergny et al. 2006; Copetti et al. 2009). The contradictory nature of these results is likely explained through cell type and context specific requirements for autophagy. Also, the regulation of autophagy in cancer cells is still unclear; autophagy serves a tumor suppressive mechanism in response to early transforming events and then seems to switch to promote tumor progression once tumors have been established (Mathew & White 2011). Moreover, considering that many cancer cells display constitutive activation of NF- κ B, these may not be the best cells to address the question of how NF- κ B modulates autophagy. Indeed, our own studies of this question have produced a number of inconsistent results between cancer cell lines, indicating that the complex regulation of autophagy and NF- κ B in cancer is likely specific to the oncogene addicted pathways driving the malignant state. Accordingly, a better understanding of the role of NF- κ B in physiological regulation of autophagy in response to classic stimuli, such as metabolic starvation, will lead to a better understanding of these pathways in disease pathogenesis (see Chapter 4).

Criollo et al. very clearly established that IKK activity is required for the induction of autophagy in response to most stimuli in mammalian cells (2009). Briefly, the authors demonstrated that IKK activity is induced in response to autophagy inducing stimuli including cellular starvation, mTOR inhibition with Rapamycin, p53 inhibition with pifithrin- α , and ER stress-inducing agent Tunicamycin. Moreover, loss of canonical IKK subunits NEMO, IKK β , IKK α , or the upstream kinase Tak1 significantly impaired starvation-

induced autophagy (Criollo et al. 2009). Perhaps the most interesting finding reported by Criollo was that IKK-dependent control of autophagy occurred independently of the ability to regulate NF- κ B transcription factors. Specifically, no defects in stimulus induced autophagy were observed in cells lacking the p65 NF- κ B subunit or cells expressing a dominant negative I κ B that is unable to be phosphorylated and activated by IKK; thus IKK is able to promote autophagy even in the absence of NF- κ B activity. These results are in clear disagreement with those discussed above. Certainly, further investigation of these effects is necessary to begin to understand how NF- κ B contributes to control of metabolic activity.

1.5 Phosphoinositide 3-Kinase

PI3Ks are intracellular lipid kinases that phosphorylate the 3'-hydroxyl group of phosphoinositides involved in an array of biological processes from vesicle trafficking to cellular signaling (Cantley 2002). Receptor Tyrosine Kinases (RTKs) activate Class1A PI3K molecules to phosphorylate phosphatidylinositol-4,5,-bisphosphate (PIP₂) generating phosphatidylinositol-3,4,5,-triphosphate (PIP₃), an important second messenger in cells. Class 1A PI3K molecules are obligate heterodimers of regulatory p85 and catalytic p110 subunits (Figure 1.4) (Engelman et al. 2006). p85 subunits are essential for PI3K activity but paradoxically loss of expression is associated with increased insulin sensitivity and overexpression leads to insulin resistance. Thus p85 regulatory subunits tightly control PI3K activity by both activating and inhibiting the p110 subunits, depending on the cellular context (Luo & Cantley 2005). Absent stimulus, p85 stabilizes and inhibits p110 activity. Following activation of RTKs by GFs such as Insulin PI3K is recruited to the plasma membrane via

association of p85 SH2 domains with tyrosine-phosphorylated residues on receptors and adaptors (Engelman et al. 2006). p85 SH2 phospho-tyrosine binding promotes PI3K activity by both properly localizing PI3K to the plasma membrane and by relieving p85 inhibitory effects resulting in increased lipid kinase activity (Yu et al. 1998). Free (monomeric) p85 can also inhibit PI3K signaling by binding to tyrosine phosphorylated adaptors like IRS and sequestering them from PI3K holoenzymes complexes (Luo et al. 2005).

Feedback control of PI3K is an important aspect of downstream signal transduction especially in light of the fact that mutations in PI3K that lead to constitutive activation are oncogenic (Samuels et al. 2004). The lipid phosphatase PTEN dephosphorylates PIP3 to provide another level of control restrict signaling downstream of PI3K (Sansal & Sellers 2004). Finally, activated mTORC1 downstream of PI3K is involved in feedback inhibition of signaling in response (see below). Roles for p85 subunits, PTEN, and mTORC1/IRS in feedback control of PI3K underlie the importance of restricting PI3K activity and is supported by the fact 30% of breast, endometrial, prostate and cervix tumors are driven by oncogenic addiction to this pathway (current numbers from SU2C Foundation).

1.6 Akt

The serine/threonine kinase Akt is a primary effector molecule activated downstream of PI3K signaling. Formation of PIP3 results in Akt recruitment to the plasma membrane via lipid binding through its PH domain. Full activation of Akt occurs following a series of phosphorylation events at the plasma membrane involving PDK-1-dependent phosphorylation of Threonine-308 and an mTOR-dependent phosphorylation at Serine-473

(Alessi et al. 1997; Sarbassov et al. 2005a). Akt controls wide-ranging aspects of cell survival and metabolism in response to activation by phosphorylating a diverse set of substrates downstream (Manning & Cantley 2007). Interestingly, control of two substrates in particular, Tuberin and FOXO3a more recently, has led to the suggestion that Akt is a primary regulator of autophagy in mammalian cells (Mammucari et al. 2008). The discovery that Akt-dependent phosphorylation of Tuberin promotes activation of mTOR was an important finding that linked control of the ancient TOR pathway with upstream GF-dependent signaling in higher eukaryotes (Manning et al. 2002; Inoki et al. 2002; Potter et al. 2002). AKT further controls activation of mTOR signaling through phosphorylation and inhibition of TOR inhibitory protein PRAS40 (Sancak et al. 2007). Finally, Akt negatively regulates the activity of the tumor suppressor FOXO transcription factor family by phosphorylating a critical Threonine residue important for nuclear export and cytoplasmic sequestration (Manning & Cantley 2007). The FOXO family has recently been studied for its ability to regulate autophagy in skeletal muscle which is blocked in response to Akt activation (Mammucari et al. 2007). In the examples above, Akt negatively regulates autophagy in response to GF-induced stimulation by direct phosphorylation and modulation of substrates important for promoting this activity in mammalian cells. Nevertheless, control of autophagy in higher eukaryotes is highly complex and still poorly understood.

1.7 Mammalian Target of Rapamycin

mTOR is a serine/threonine kinase family member of PI3K-related Kinases (PIKKs) that coordinates metabolic activity by sensing nutrients, oxygen, and stress. mTOR exists in

two distinct complexes in the cell, mTORC1 and mTORC2, which are defined by the presence of a mutually exclusive adaptor molecule, Raptor or Rictor, respectively (Zoncu et al. 2011). Activated mTORC1 results in increased protein synthesis by phosphorylation and activation of S6K and inhibition of 4E-BP1 but also drives processes such as lipid synthesis and glycolysis; the result of activated mTORC1 then is biomass accumulation and increases in cell size (Sarbasov et al. 2005b). In the presence of AA-activated RagGTPase dimers, in association with Ragulator, recruit mTORC1 to the lysosomal surface, where another small GTPase Rheb drives activity (Sancak & Sabatini 2009)(Sancak et al. 2010). While much of the biochemical control of mTORC1 control has been worked out the biological consequences downstream are still largely unknown. Recent studies have advanced our knowledge of transcriptional activity induced downstream of mTOR activation but in doing so also unveiled even more questions of how mTOR regulates this previously unknown activity (Düvel et al. 2010). Future studies will likely focus on defining novel substrates of mTORC1 to understand how it controls such a diverse array of metabolic features in the animal (Polak & Hall 2009).

mTORC2 shares some of the proteins that make up the mTORC1 complex but is defined by interaction with Sin1 and Rictor. mTORC2 is nutrient- and Rapamycin-insensitive and was discovered for its ability to regulate the cytoskeleton (Cybulski & Hall 2009). More recently mTORC2 was discovered to be the elusive Hydrophobic Motif (HM) Kinase for the AGC family kinases including the critical Akt site Ser473 (Sarbasov et al. 2005a). These findings indicate that mTOR activity is important both upstream (mTORC2)

and downstream (mTORC1) of AKT , revealing a complex coordination of PI3K/Akt/mTOR signaling network, the implications of which are discussed below.

1.8 PI3K/Akt/mTOR Signaling Network

The last half decade has resulted in a marked increase in our understanding of the molecular mechanisms controlling cell growth and metabolism in response to growth factors and nutrients. In animals we've learned that much of this control comes from the integration of signals by the PI3K/Akt/mTOR signaling axis; coordinated activation of this pathway results in a major program that drives cell growth, proliferation, and survival (Engelman et al. 2006; Manning & Cantley 2007; Zoncu et al. 2011). The mechanisms by which GFs drive signaling from PI3K/Akt to mTOR activity have been covered extensively above and can also be found in Figure 1.5. This section will focus on on the interconnectedness and complex crosstalk that exists within this network in mammalian cells.

The complexity of the PI3K/Akt/mTOR signaling axis in animals can be easier understood when it is considered that this pathway did not co-evolve, rather GF-activated PI3K/Akt merged with the nutrient regulated TOR pathway to control aspects of cell metabolism already dependent on TOR. As animals evolved to regulate mTOR downstream of growth factors by way of PI3K/Akt they also co-evolved a mechanism of feedback to restrict the upstream input from GF-dependent signals and prevent hyper-activation of this metabolic activity. The mTORC1 effector molecule S6K phosphorylates IRS1 and IRS2 adaptor molecules, which are important for insulin-induced signaling, to regulate both

stability and association with IR(Harrington et al. 2004) . This feedback loop describes yet another mechanisms cells use to restrict PI3K signaling in basally growing cells.

The finding that mTORC2 controls AKT phosphorylation was a bit paradoxical given that AKT drives mTORC1 activity. Control and function of Ser473 phosphorylation has been extensively studied for over a decade and only recently was a consensus reached that mTORC2 is the primary Ser473 kinase, though other examples that promote activity exist as well (Toker & Newton 2000; Ou et al. 2011). While intrinsic mTORC2 activity can be increased by serum stimulation, current thinking is that mTORC2 is a constitutively active at the plasma membrane which phosphorylates Akt when it is recruited upon PI3K activation. Therefore, since AKT S473 phosphorylation is considered to be controlled by membrane localization to PIP3 (from PI3K) rather than an increase in upstream mTORC2 catalytic activity, Ser473 phosphorylation serves as a better indicator of PI3K activity than it does mTORC2 activity (Huang & Manning 2009; Hietakangas & Cohen 2007).

1.9 Conclusions

While much is left to learn, a pretty clear understanding of the basic principles governing GF- and nutrient-dependent control of cell metabolism has emerged in the last few years. Our current understanding of how cells sense stress to impinge upon cell growth and metabolism is less well defined. Certainly, the complexity of this pathway in animal cells is reflected in the very diverse nature of inputs that can control cell growth. Cells are also sensing and responding to stresses, and maintaining increased growth and metabolism under conditions of stress, especially nutrient depletion, could be potentially deleterious. This

emphasizes the need for tight control of inflammatory signaling and growth signaling through coordination of cellular signaling events. Hyperactivation of either pathway is a common perturbation associated with a number of human pathologies, which supports that activation of these pathways must be limited. Understanding the coordination of these pathways will then be an important step toward understanding nature of human disease.

This chapter has explored our current understanding of inflammatory networks controlled by IKK/NF- κ B signaling and metabolic networks controlled by PI3K/Akt/mTOR. In the remaining chapters crosstalk between these two pathways will be explored. Evidence will be presented that IKK activity promotes a number of survival functions in response to the novel IKK/NF- κ B-inducing stimulus nutrient deprivation. Specifically, we identify a pro-autophagic gene expression program that is induced in an IKK-dependent manner following prolonged starvation. We also identify signaling roles for IKK in restricting PI3K/Akt activity in response to starvation through direct phosphorylation and modulation of PI3K p85 regulatory subunits. These results will identify IKK as critical signaling molecule important for the response of a cell to limiting nutrient availability and further extend the role of IKK as an essential survival molecule downstream of cell stress.

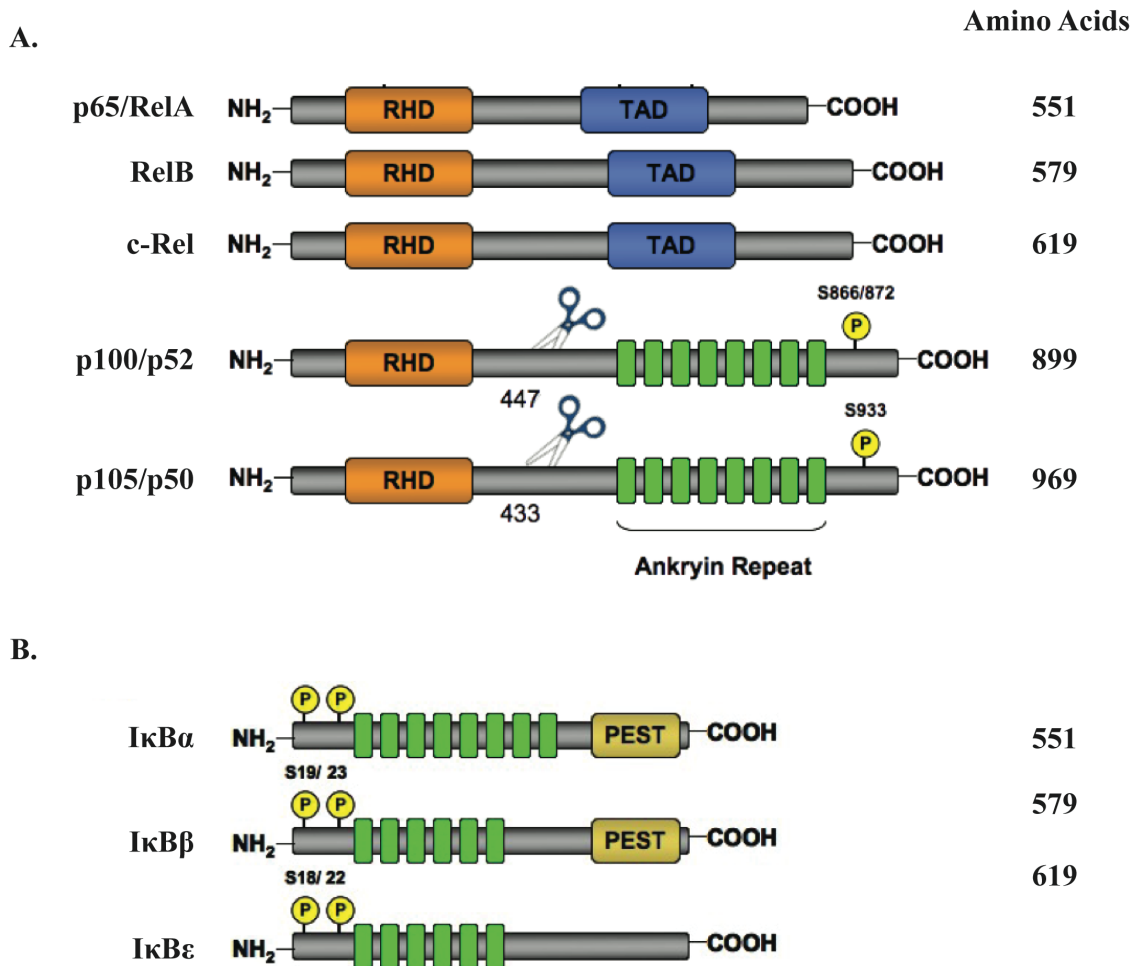

Figure 1.1 Domain organization of the NF-κB and IκB family members.

A. NF-κB family members are characterized by an N-terminal Rel Homology Domain (RHD, orange). Rel family members include RelA, RelB, and c-Rel which each have a Transcriptional Activation Domain (TAD, blue) required for transcriptional activity of NF-κB dimers. NF-κB family members p100/p52 and p105/p50 lack a TAD but contain C-terminal ankyrin repeats homologous to those found in IκB proteins (green) (see below). These members undergo proteolytic cleavage (site indicated by scissors) in response to phosphorylation in the c-terminus (sites are indicated).

B. IκB family members are characterized by N-terminal ankyrin repeats. The sites of phosphorylation that promote proteasome-dependent degradation are indicated in yellow. (Figure is adapted from E. Merkhofer, 2009).

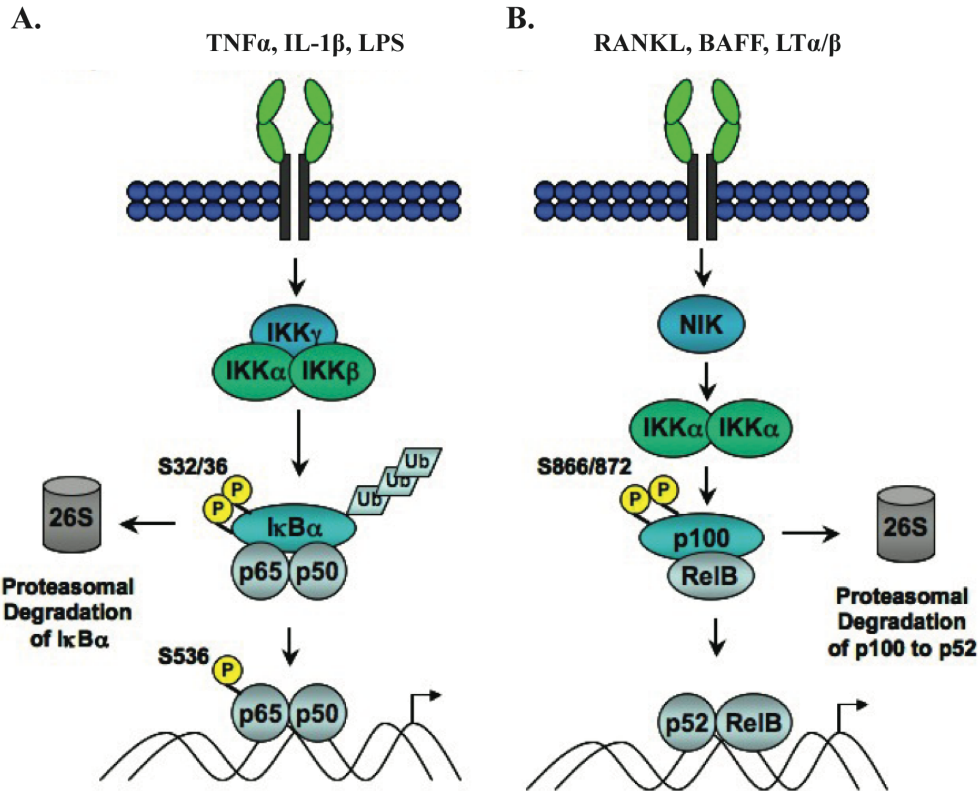

Figure 1.2 Pathways of NF- κ B activation.

A. Canonical NF- κ B is induced in response to cytokines and chemokines to activate the IKK complex. IKK β -dependent phosphorylation of Ser32/36 on I κ B promotes proteasome dependent degradation, releasing NF- κ B dimers p65/p50 to bind DNA and regulate gene expression.

B. Non-canonical NF- κ B is induced in response to a subset of TNFR family member ligand binding. NIK promotes activation of NEMO-independent IKK α homodimers which phosphorylate p100 in the c-terminus at Ser866/872 to promote proteolytic cleavage of c-terminal ankyrin repeats, resulting in nuclear localization of p52/RelB NF- κ B dimers.

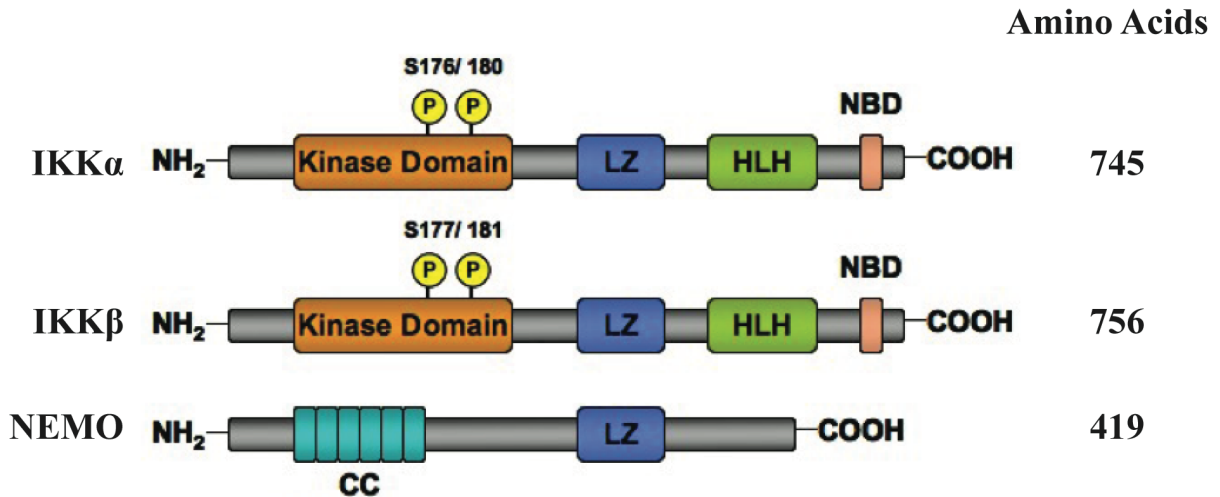

Figure 1.3 Domain organization of the canonical IKK subunits

IKK α and IKK β catalytic subunits have a highly homologous N-terminal kinase domain (orange). Activation loop phosphorylation sites important for activity are indicated in yellow. Catalytic subunits also share Leucine zipper (LZ), Helix-Loop-Helix (HLH), and NEMO Binding Domains (NBD). The LZ domains facilitate complex assembly by promoting dimerization of IKK subunits. HLH domains are important for catalytic activity, are heavily modified post-translationally, and likely serve intramolecular support for association with the kinase domains. NBD promotes association with the NEMO regulatory subunit, which is also essential for activity. NEMO N-terminal coiled-coiled (CC) domains as well as a LZ, both of which are important for NEMO oligomerization. (Figure is adapted from E. Merkhofer, 2009).

p85 Regulatory (p85 α /p50 α /p55 α , p85 β , p55 γ)



p110 Catalytic (p110 α , p110 β , p110 δ)



Figure 1.4 Domain organization of Class1A PI3K subunits

Class1A PI3K holoenzyme is an obligate heterodimer of p85 regulatory subunits and p110 catalytic subunits. p85 subunits are encoded by three different genes p85 α , β , and γ and all share the c-terminal region containing an inter-SH2 domain important for p110 binding flanked by dual SH2 domains important for activated RTK-mediated membrane localization. p85 α and p85 β also have N-terminal SH3 domains as well as a BCR Homology (BH) domain that is flanked by Proline-rich (P) regions. p110 subunits are encoded by three distinct genes and contain N-terminal domains that facilitate binding to p85 regulatory subunits as well as the small GTPase Ras. They also contain a C2 domain, Phosphatidylinositol kinase homology (PIK) domain and a C-terminal catalytic domain.

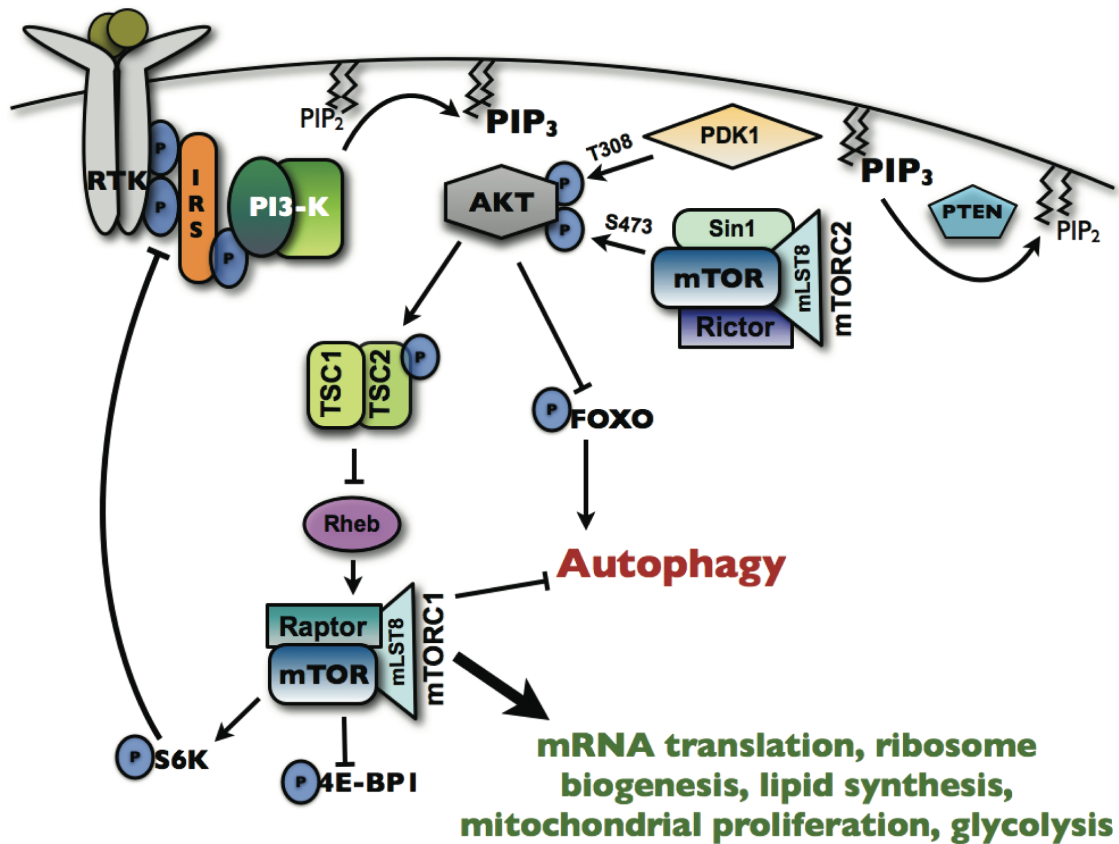

Figure 1.5 Signaling through PI3K/Akt/mTOR axis in higher eukaryotes

Growth factor activation of Receptor Tyrosine Kinases (RTK) lead to recruitment of PI3K to the plasma membrane via interaction with p85-SH2 domains and phosphorylated tyrosine residues on activated RTKs. PI3K phosphorylates phosphatidylinositol-4,5,-bisphosphate (PIP₂) generating phosphatidylinositol-3,4,5,-triphosphate (PIP₃) which recruits PH and PX lipid binding domain-containing proteins like Akt to the plasma membrane. Akt recruitment to the membrane results in activation following PDK1-dependent phosphorylation of Thr308 and mTORC2-dependent phosphorylation of Ser473. Akt phosphorylates a number of effector molecules including FOXO proteins and TSC2 which results in activation of mTOR. Akt-dependent phosphorylation of FOXO and TSC2 leads to inhibition of autophagy. Activated mTORC1 drives a metabolic program (indicated in green text), in part through phosphorylation of S6K and 4E-BP1. Activated S6K results in feedback inhibition of PI3K upstream through phosphorylation and modulation of IRS proteins.

REFERENCES

- Adhikari, A., Xu, M. & Chen, Z.J., 2007. Ubiquitin-mediated activation of TAK1 and IKK. *Oncogene*, 26(22), pp.3214-3226.
- Alessi, D.R. et al., 1997. Characterization of a 3-phosphoinositide-dependent protein kinase which phosphorylates and activates protein kinase B α . *Current biology : CB*, 7(4), pp.261-269.
- Atreya, I., Atreya, R. & Neurath, M.F., 2008. NF-kappaB in inflammatory bowel disease. *Journal of internal medicine*, 263(6), pp.591-596.
- Baker, R.G., Hayden, M.S. & Ghosh, S., 2011. NF- κ B, inflammation, and metabolic disease. *Cell metabolism*, 13(1), pp.11-22.
- Bassères, D.S. & Baldwin, A.S., 2006. Nuclear factor-kappaB and inhibitor of kappaB kinase pathways in oncogenic initiation and progression. *Oncogene*, 25(51), pp.6817-6830.
- Bonizzi, G. et al., 2004. Activation of IKK α target genes depends on recognition of specific kappaB binding sites by RelB:p52 dimers. *The EMBO Journal*, 23(21), pp. 4202-4210.
- Cantley, L.C., 2002. The phosphoinositide 3-kinase pathway. *Science (New York, NY)*, 296(5573), pp.1655-1657.
- Copetti, T. et al., 2009. p65/RelA modulates BECN1 transcription and autophagy. *Molecular and Cellular Biology*, 29(10), pp.2594-2608.
- Criollo, A. et al., 2009. The IKK complex contributes to the induction of autophagy. *The EMBO Journal*.
- Cybulski, N. & Hall, M.N., 2009. TOR complex 2: a signaling pathway of its own. *Trends in biochemical sciences*, 34(12), pp.620-627.
- Delgado, M.A. et al., 2008. Toll-like receptors control autophagy. *The EMBO Journal*, 27(7), pp. 1110-1121.
- Djavaheri-Mergny, M. et al., 2006. NF-kappaB activation represses tumor necrosis factor- α -induced autophagy. *The Journal of biological chemistry*, 281(41), pp. 30373-30382.
- Dutta, J. et al., 2006. Current insights into the regulation of programmed cell death by NF-kappaB. *Oncogene*, 25(51), pp.6800-6816.

- Düvel, K. et al., 2010. Activation of a metabolic gene regulatory network downstream of mTOR complex 1. *Molecular Cell*, 39(2), pp.171-183.
- Engelman, J.A., Luo, J. & Cantley, L.C., 2006. The evolution of phosphatidylinositol 3-kinases as regulators of growth and metabolism. *Nature Reviews Genetics*, 7(8), pp. 606-619.
- Fitzgerald, K.A. et al., 2003. IKKepsilon and TBK1 are essential components of the IRF3 signaling pathway. *Nature immunology*, 4(5), pp.491-496.
- Gilmore, T.D., 2006. Introduction to NF-kappaB: players, pathways, perspectives. *Oncogene*, 25 (51), pp.6680-6684.
- Gloire, G. et al., 2007. Promoter-dependent effect of IKKalpha on NF-kappaB/p65 DNA binding. *The Journal of biological chemistry*, 282(29), pp.21308-21318.
- Harrington, L.S. et al., 2004. The TSC1-2 tumor suppressor controls insulin-PI3K signaling via regulation of IRS proteins. *The Journal of Cell Biology*, 166(2), pp.213-223.
- Hayden, M.S. & Ghosh, S., 2004. Signaling to NF-kappaB. *Genes & Development*, 18(18), pp. 2195-2224.
- Häcker, H. & Karin, M., 2006. Regulation and function of IKK and IKK-related kinases. *Science's STKE : signal transduction knowledge environment*, 2006(357), p.re13.
- Hietakangas, V. & Cohen, S.M., 2007. Re-evaluating AKT regulation: role of TOR complex 2 in tissue growth. *Genes & Development*, 21(6), pp.632-637.
- Hoffmann, A., Natoli, G. & Ghosh, G., 2006. Transcriptional regulation via the NF-kappaB signaling module. *Oncogene*, 25(51), pp.6706-6716.
- Hu, M.C. et al., 2004. IkappaB kinase promotes tumorigenesis through inhibition of forkhead FOXO3a. *Cell*, 117(2), pp.225-237.
- Huang, J. & Manning, B.D., 2009. A complex interplay between Akt, TSC2 and the two mTOR complexes. *Biochemical Society transactions*, 37(Pt 1), pp.217-222.
- Hutti, J.E. et al., 2007. IkappaB kinase beta phosphorylates the K63 deubiquitinase A20 to cause feedback inhibition of the NF-kappaB pathway. *Molecular and Cellular Biology*, 27(21), pp.7451-7461.

- Inoki, K. et al., 2002. TSC2 is phosphorylated and inhibited by Akt and suppresses mTOR signalling. *Nature Cell Biology*, 4(9), pp.648-657.
- Kawai, T. & Akira, S., 2007. Signaling to NF-kappaB by Toll-like receptors. *Trends in molecular medicine*, 13(11), pp.460-469.
- Klionsky, D J, 2000. Autophagy as a Regulated Pathway of Cellular Degradation. *Science (New York, NY)*, 290(5497), pp.1717-1721.
- Klionsky, Daniel J, 2005. Autophagy. *Current biology : CB*, 15(8), pp.R282-3.
- Lee, D. et al., 2007. IKK beta suppression of TSC1 links inflammation and tumor angiogenesis via the mTOR pathway. *Cell*, 130(3), pp.440-455.
- Levine, B. & Kroemer, G., 2008. Autophagy in the pathogenesis of disease. *Cell*, 132(1), pp. 27-42.
- Levine, B., Mizushima, N. & Virgin, H.W., 2011. Autophagy in immunity and inflammation. *Nature*, 469(7330), pp.323-335.
- Luo, J. & Cantley, L.C., 2005. The negative regulation of phosphoinositide 3-kinase signaling by p85 and its implication in cancer. *Cell cycle (Georgetown, Tex)*, 4(10), pp.1309-1312.
- Luo, J. et al., 2005. The p85 regulatory subunit of phosphoinositide 3-kinase down-regulates IRS-1 signaling via the formation of a sequestration complex. *The Journal of Cell Biology*, 170(3), pp.455-464.
- Mammucari, C., Schiaffino, S. & Sandri, M., 2008. Downstream of Akt: FoxO3 and mTOR in the regulation of autophagy in skeletal muscle. *Autophagy*, 4(4), pp.524-526.
- Mammucari, C. et al., 2007. FoxO3 controls autophagy in skeletal muscle in vivo. *Cell metabolism*, 6(6), pp.458-471.
- Manning, B.D. & Cantley, L.C., 2007. AKT/PKB signaling: navigating downstream. *Cell*, 129 (7), pp.1261-1274.
- Manning, B.D. et al., 2002. Identification of the tuberous sclerosis complex-2 tumor suppressor gene product tuberlin as a target of the phosphoinositide 3-kinase/akt pathway. *Molecular Cell*, 10(1), pp.151-162.
- Mathew, R. & White, E., 2011. Autophagy in tumorigenesis and energy metabolism: friend by day, foe by night. *Current opinion in genetics & development*, 21(1), pp.113-119.

- Mizushima, N. & Levine, B., 2010. Autophagy in mammalian development and differentiation. *Nature Cell Biology*, 12(9), pp.823-830.
- Ou, Y. et al., 2011. TBK1 Directly Engages Akt/PKB Survival Signaling to Support Oncogenic Transformation. *Molecular Cell*, 41(4), pp.458-470.
- Pattingre, S. et al., 2005. Bcl-2 antiapoptotic proteins inhibit Beclin 1-dependent autophagy. *Cell*, 122(6), pp.927-939.
- Polak, P. & Hall, M.N., 2009. mTOR and the control of whole body metabolism. *Current Opinion in Cell Biology*, 21(2), pp.209-218.
- Potter, C.J., Pedraza, L.G. & Xu, T., 2002. Akt regulates growth by directly phosphorylating Tsc2. *Nature Cell Biology*, 4(9), pp.658-665.
- Raught, B., Gingras, A.C. & Sonenberg, N., 2001. The target of rapamycin (TOR) proteins. *Proceedings of the National Academy of Sciences of the United States of America*, 98 (13), pp.7037-7044.
- Samuels, Y. et al., 2004. High frequency of mutations of the PIK3CA gene in human cancers. *Science (New York, NY)*, 304(5670), p.554.
- Sancak, Y. & Sabatini, D.M., 2009. Rag proteins regulate amino-acid-induced mTORC1 signalling. *Biochemical Society transactions*, 37(Pt 1), pp.289-290.
- Sancak, Y. et al., 2007. PRAS40 is an insulin-regulated inhibitor of the mTORC1 protein kinase. *Molecular Cell*, 25(6), pp.903-915.
- Sancak, Y. et al., 2010. Ragulator-Rag complex targets mTORC1 to the lysosomal surface and is necessary for its activation by amino acids. *Cell*, 141(2), pp.290-303.
- Sansal, I. & Sellers, W.R., 2004. The biology and clinical relevance of the PTEN tumor suppressor pathway. *Journal of clinical oncology : official journal of the American Society of Clinical Oncology*, 22(14), pp.2954-2963.
- Sarbassov, D D et al., 2005a. Phosphorylation and regulation of Akt/PKB by the rictor-mTOR complex. *Science (New York, NY)*, 307(5712), pp.1098-1101.
- Sarbassov, Dos D, Ali, S.M. & Sabatini, D.M., 2005b. Growing roles for the mTOR pathway. *Current Opinion in Cell Biology*, 17(6), pp.596-603.

- Scheidereit, C., 2006. IkappaB kinase complexes: gateways to NF-kappaB activation and transcription. *Oncogene*, 25(51), pp.6685-6705.
- Sengupta, S., Peterson, T.R. & Sabatini, D.M., 2010. Regulation of the mTOR complex 1 pathway by nutrients, growth factors, and stress. *Molecular Cell*, 40(2), pp.310-322.
- Skaug, B., Jiang, X. & Chen, Z.J., 2009. The role of ubiquitin in NF-kappaB regulatory pathways. *Annual review of biochemistry*, 78, pp.769-796.
- Solt, L.A. et al., 2007. Interleukin-1-induced NF-kappaB activation is NEMO-dependent but does not require IKKbeta. *The Journal of biological chemistry*, 282(12), pp. 8724-8733.
- Toker, A. & Newton, A.C., 2000. Akt/protein kinase B is regulated by autophosphorylation at the hypothetical PDK-2 site. *The Journal of biological chemistry*, 275(12), pp. 8271-8274.
- Yorimitsu, T. & Klionsky, D J, 2005. Autophagy: molecular machinery for self-eating. *Cell Death and Differentiation*, 12 Suppl 2, pp.1542-1552.
- Yu, J. et al., 1998. Regulation of the p85/p110 phosphatidylinositol 3'-kinase: stabilization and inhibition of the p110alpha catalytic subunit by the p85 regulatory subunit. *Molecular and Cellular Biology*, 18(3), pp.1379-1387.
- Zoncu, R., Efeyan, A. & Sabatini, D.M., 2011. mTOR: from growth signal integration to cancer, diabetes and ageing. *Nature Reviews Molecular Cell Biology*, 12(1), pp.21-35.

Chapter Two

IKK-DEPENDENT, NF- κ B-INDEPENDENT CONTROL OF AUTOPHAGIC GENE EXPRESSION¹

¹ This chapter has been adapted from: Comb, W. C., Cogswell, P., Sitcheran, R., & Baldwin, A. S. (2010). IKK-dependent, NF- κ B-independent control of autophagic gene expression. *Oncogene*, 30(14), 1727-1732. doi:10.1038/onc.2010.553

2.1 Abstract

The induction of mammalian autophagy, a cellular catabolic bulk-degradation process conserved from humans to yeast, was recently shown to require IKK, the upstream regulator of the NF- κ B pathway. Interestingly, it was shown that this response did not involve classic NF- κ B. Thus, the mechanism by which IKK promotes stimulus-induced autophagy is largely unknown. Here we investigate the role of IKK/NF- κ B in response to nutrient deprivation, the classic autophagy-inducing stimulus. IKK and both the classic and non-canonical pathways of NF- κ B are robustly induced in response to cellular starvation. Notably, cells lacking either catalytic subunit of IKK (IKK α or IKK β) fail to induce autophagy in response to cellular starvation. Importantly, we show that IKK activity but not NF- κ B, controls basal expression of the pro-autophagic gene LC3. We further demonstrate that starvation induces the expression of LC3 and two other essential autophagic genes, ATG5 and Beclin-1, in an IKK-dependent manner. These results demonstrate that the IKK complex is a central mediator of starvation-induced autophagy in mammalian cells and suggest that this requirement occurs at least in part through the regulation of autophagic gene expression. Interestingly, NF- κ B subunits are dispensable for both basal and starvation-induced expression of pro-autophagic genes. However, starvation-induced activation of NF- κ B is not inconsequential as increases in expression of anti-apoptotic NF- κ B target genes such as cIAP2 is observed in response to cellular starvation. Thus, IKK likely plays multiple roles in response to starvation by regulating NF- κ B-dependent anti-apoptotic gene expression as well as controlling expression of autophagic genes through a yet undetermined mechanism.

2.2 Introduction

The IKK/NF- κ B signaling axis is a major molecular regulator of inflammatory signaling and stress responses in mammalian cells. NF- κ B is a transcription factor composed of homo- and hetero-dimeric complexes of five subunits (p65/RelA, c-Rel, RelB, p105/p50, and p100/p52), which regulate the expression of a numerous target genes in response to a variety of cellular signals and stresses (Gilmore, 2006). NF- κ B is known be activated by two different pathways each requiring a distinct IKK subunit. The classical pathway involves IKK α , regulates NF- κ B complexes containing p65 and c-Rel, and is most well understood in response to inflammatory cytokines like TNF α . The alternative or non-canonical pathway is activated primarily in lymphoid tissue, is IKK β -dependent, and controls NF- κ B complexes containing RelB and p52 (Hayden and Ghosh, 2004). Regulation of NF- κ B activity is quite diverse and occurs in response to various signals including DNA damage, cell cycle, and metabolic conditions like glucose availability or redox status (Barré and Perkins, 2007; Bednarski *et al.*, 2009; Bubici *et al.*, 2006). Therefore there is much interest in understanding the role IKK/NF- κ B activity plays in facilitating a cell's response to its changing environment.

IKK is a large multi-subunit complex consisting of a regulatory subunit (NEMO) and two catalytic subunits (IKK α and IKK β). IKK activates NF- κ B by phosphorylating a class of inhibitory molecules called Inhibitor of κ B (I κ B), marking them for proteosome- dependent degradation. IKK-dependent phosphorylation of I κ B results in NF- κ B nuclear translocation and transcriptional activation of target genes (Hacker and Karin, 2006). To date, investigation of IKK activity has focused on its role as the critical mediator of NF- κ B regulation. More

recently IKK, but not NF- κ B, was demonstrated to be required for induction of the cellular catabolic process macro-autophagy (herein referred to as autophagy) (Criollo *et al.*, 2009), however, the mechanism by which IKK controls autophagy is unclear. Autophagy is a bulk-degradation process utilized by cells to maintain energy homeostasis and adapt to nutrient availability. Autophagy is characterized by double-membraned organelles called autophagosomes, which engulf cytoplasmic components including macromolecules, organelles, and damaged cellular material. Autophagosomes fuse with the lysosome where its contents are degraded and recycled by digestive enzymes (Klionsky, 2004). In so doing, autophagy serves as a housekeeping mechanism, preventing accumulation of potentially toxic molecules. Autophagy is also induced in response to changing metabolic states, the most classically studied model being cellular starvation. During starvation cells up-regulate autophagy, promoting turnover of its own contents as a means supplying essential nutrients (Klionsky, 2004).

The machinery that controls autophagy is conserved from yeast to humans, but regulation of autophagy in higher organisms is more complex. Signaling pathways important for regulation of autophagy have also been implicated in human disease progression, thus there is major interest in understanding how these pathways contribute to autophagy and how autophagy promotes disease pathogenesis (Levine and Kroemer, 2008). Here we investigate the role IKK/NF- κ B signaling pathways play in regulating autophagy in response to the classic autophagy-inducing stimulus cell starvation. Data presented herein demonstrate that both classical and non-canonical pathways of NF- κ B activation are induced in response to cellular starvation. Importantly, both catalytic subunits of the IKK complex (IKK β and

IKK α) are required for starvation-induced autophagy. IKK subunits are further demonstrated to control expression of pro-autophagic genes, but this effect is independent of NF- κ B activity. These results suggest that IKK-dependent induction of autophagy occurs in part through regulation of the genes necessary for this process.

2.3 Results and Discussion

Cellular starvation induces both classical and non-canonical NF- κ B pathways

To understand the role IKK/NF- κ B signaling plays in regulation of autophagy, the activity of these molecules was analyzed in cells undergoing nutrient starvation, the classic autophagy-inducing stimulus. Treatment of wildtype (WT) mouse embryonic fibroblasts (mEFs) with starvation media resulted in phosphorylation and degradation of I κ B α and phosphorylation of NF- κ B subunit p65, markers associated with activation of the classical NF- κ B pathway (Figure 2.1A). An important step during induction of autophagy occurs when LC3, an essential component of the autophagosome machinery, is cleaved, lipidated, and incorporated into an elongating autophagosome. This processed form of LC3 (LC3-II) migrates faster on a gel than its precursor (LC3-I) and therefore the ratio of these species is often used as an indicator of increased autophagy (Klionsky *et al.*, 2008). Notably, activation of NF- κ B occurred rapidly following starvation and preceded LC3 processing (Figure 2.1A). Nuclear extracts prepared from nutrient deprived mEFs displayed increased binding to a consensus κ B DNA oligonucleotide in an electrophoretic mobility shift assay (EMSA) (Figure 2.1B).

Importantly, nutrient-deprivation induced DNA binding occurred in a cyclical manner, consistent with most examples of stimulus-induced NF- κ B activation (Renner and Schmitz, 2009; Sacconi *et al.*, 2001), but signal intensity was less than that observed with TNF α stimulation. EMSA supershift analysis with antibodies against NF- κ B subunits demonstrated that this complex consists of classical NF- κ B hetero-dimer p65/p50 (Figure 2.1B). Finally, target gene expression was assessed in order to determine if starvation induces activation of functional NF- κ B. Expression of the classic NF- κ B target gene NFKBIA was dramatically increased in response to starvation (Figure 2.1C). Specifically, a four-fold increase in NFKBIA expression occurred within the first two hours of starvation and a secondary increase in expression (almost 10-fold) was observed following 8 hours of starvation. Taken together, nutrient starvation results in increased signaling markers of activated NF- κ B, DNA binding, and target gene expression, indicating that activation of canonical NF- κ B occurs in response to cellular starvation.

Processing of p100/p52 was monitored in order to determine if the non-canonical NF- κ B pathway is also activated in response to starvation. Whereas activation of classical NF- κ B activity occurred rapidly following starvation, p100/p52 processing was observed under periods of prolonged starvation, where accumulation of p52 was observed at 12 hours (Figure 2.1D). Total levels of unprocessed p100 also increased in response to starvation suggesting that prolonged nutrient stress may promote increased NF- κ B activity through regulation of subunit expression. In this regard, p100/p52 gene NFKB2 is itself an NF- κ B target gene (Lombardi *et al.*, 1995) raising the possibility that NF- κ B participates in a feed-forward mechanism to achieve maximal activity through control of subunit expression. The

contribution of increases in p100 expression versus induced p100 processing is currently unclear; nevertheless starvation results in marked accumulation of p52. More investigation will be necessary to determine a role for non- canonical NF- κ B signaling in response to starvation.

IKK controls basal and starvation-induced expression of pro-autophagic genes.

Having observed activation of IKK and multiple NF- κ B subunits in response to cellular starvation, the role of IKK in regulating autophagy was next examined. Cells lacking IKK subunits fail to induce LC3 processing in response to starvation as monitored by the conversion of the unprocessed LC3-I species to the cleaved, lipidated, autophagy- specific species LC3-II (Figure 2.2A). Measurements using alternative autophagy detection techniques including GFP-LC3 puncta, and endogenous LC3 subcellular localization, confirm the results of Criollo *et al.* (2009) that IKK is required for starvation- induced autophagy (data not shown). This data indicates that IKK catalytic subunits are important for autophagy, which may imply distinct activities for IKK α and IKK β . Pharmacological inhibition of IKK in WT mEFs with multiple IKK-specific compounds confirmed that IKK is required for starvation-induced autophagy (data not shown). Importantly, cells lacking IKK α or IKK β displayed a marked decrease in LC3 protein expression compared to WT mEFs (Figure 2.2A).

Having observed IKK-dependent effects on LC3 expression and noting that starvation induces IKK activity and NF- κ B target gene expression, the expression of pro-autophagic genes in response to starvation was measured. Surprisingly, expression of LC3, BECN1, and

ATG5 mRNA was induced following 12 hours of starvation (Figure 2.S1). Starvation-induced expression changes were consistently statistically significant increases compared to untreated controls. Slight variability in expression increases was observed between experiments (eg. Compare WT cells in Figure 2.2B to 2.3B) but this variability is likely the result of culture conditions as we observed an inverse correlation between passage number or confluency of the cells and their ability to activate starvation-induced pro-autophagic gene expression. Considering that IKK subunits are required for starvation-induced autophagy and that starvation induces robust increases in both NF- κ B target genes and genes required for autophagy, IKK-dependent expression of LC3, BECN1, and ATG5 was measured in cells under basal growth and in response to starvation. Real Time PCR analysis of LC3 mRNA levels in WT, IKK α ^{-/-}, and IKK β ^{-/-} mEFs grown in basal medium confirmed that IKK deficient cells have decreased LC3 mRNA levels, which correlates with protein expression (Figure 2.2B). Moreover, IKK was required for starvation-induced expression LC3, Beclin-1, and Atg5 mRNA (Figure 2.2B). WT mEFs but not IKK deficient cells grown in starvation media for 12 hours display two- to five- fold increases in expression of these genes. As a control, the classic NF- κ B target gene NFKBIA is induced in WT and IKK α ^{-/-} mEFs but not cells lacking IKK β (basal levels are increased compared to WT, but fail to induce in response to starvation), consistent with a role for IKK β in controlling activation of the classical NF- κ B pathway (Figure 2.2B).

In order to confirm that starvation-induced changes in autophagic gene expression is IKK-dependent, WT mEFs were subjected to 12 hours of starvation in the presence or absence of the cell permeable NEMO-Binding Domain (NBD) peptide which disrupts an

interaction between IKK catalytic and regulatory subunits (May *et al.*, 2000). Consistent with genetic loss of IKK subunits, pharmacological inhibition of IKK with the NBD peptide blocked starvation-induced expression of LC3, BECN1, and ATG5 (Figure 2.2C). Similar results were observed when WT cells were treated with the IKK β - specific small molecule inhibitor Compound A (data not shown) (Ziegelbauer *et al.*, 2005). These results demonstrate that starvation-induced pro-autophagic gene expression requires IKK catalytic activity.

IKK-dependent expression of pro-autophagic genes does not require NF- κ B.

Previous studies have implicated NF- κ B in both positive and negative regulation of autophagy. For example, expression of p65 is sufficient to induce autophagy and is required for Beclin-1 expression in T-cells (Copetti *et al.*, 2009). On the other hand, p65 blocks TNF α -stimulated autophagy in Ewing sarcoma cells (Djavaheri-Mergny *et al.*, 2006). Given these different results, a requirement for NF- κ B subunits in regulation of autophagic gene expression was explored. p65^{-/-} mEFs were grown in basal and starvation media for 18 hours and gene expression was measured with Real Time PCR. MEFs lacking p65 displayed equivalent basal expression levels of LC3, BECN1 and ATG5. Moreover, p65 deficient mEFs consistently displayed a statistically significant increase in the expression of these genes in response to starvation (Figure 2.3A). Starvation-induced expression levels in p65 null cells were slightly lower than those for observed in WT cells which may be the result of slight variations between mEF cell lines or may indicate a slight contribution from p65 in promoting the expression of these genes (see below). Importantly, p65 null cells fail to induce NFKBIA expression in response to starvation; over an 18 hour starvation timecourse

expression levels in p65^{-/-} cells increase only two-fold compared to nearly 10-fold increases observed in WT mEFs (Figures 2.S2 and 2.1C). These results indicate that p65 is required for starvation-induced expression of classic NF- κ B target genes but not for starvation-induced pro-autophagic gene expression (see below as well).

In some instances NF- κ B family member c-Rel compensates for classical NF- κ B activation in p65 deficient cells (Hoffmann *et al.*, 2003). In order to determine if c-Rel activity was responsible for autophagic gene expression in p65-deficient cells we assayed p65/c-Rel double knock out cells (p65/c-Rel DKO), which should be devoid of any classical NF- κ B pathway activation, for basal and starvation-induced expression of LC3, BECN1, and ATG5. p65/c-Rel DKO cells displayed intact autophagic gene expression confirming that the classical NF- κ B pathway is dispensable for LC3, BECN1, and ATG5 expression (Figure 2.3A). Given that p65/c-Rel DKO mEFs displayed expression levels equivalent to WT control cells we believe that the slight decreases in expression of these genes observed in p65^{-/-} cells is likely not specific for p65 activity. Finally, a requirement for non-canonical NF- κ B subunits in basal and starvation-induced autophagic gene expression was investigated using mEFs lacking either RelB or p100/p52. Cells lacking these subunits demonstrated that non-canonical NF- κ B pathway is dispensable for autophagic gene expression as mutant and WT mEFs displayed equivalent levels of LC3, BECN1 and ATG5 under both basal and starved conditions (Figure 2.3B). Notably, RelB and p52 deficient cells also display normal starvation-induced expression levels of NFKBIA indicating that this gene is indeed regulated by classical NF- κ B dimers in response to starvation. While starvation-induced expression of pro-autophagic genes does not require non-canonical NF- κ B activity, future studies should

explore the significance of starvation-induced changes in non-canonical NF- κ B target gene expression. These studies should investigate starvation timepoints later than 12 hours since starvation-induced processing of p100 to p52 does not occur until this point (Figure 2.1D). Together, these data suggest that genetic loss of NF- κ B has no effect on either basal or starvation-induced autophagic gene expression.

The results presented in this report support the findings of Criollo et al (2009) that the IKK complex is essential for the induction of starvation-induced autophagy. We extend these findings by showing that both IKK subunits (IKK α and IKK β) control basal and starvation-induced expression of a subset of genes required for autophagy. Given that loss of either IKK catalytic subunit is sufficient to block both starvation-induced autophagy and autophagic gene expression it will be important to determine if IKK subunits participate in a co-dependent mechanism or if they have distinct functions that converge on the similar phenotypes. Importantly, pro-autophagic gene expression is not controlled by IKK-dependent activation of NF- κ B subunits, even though activation of both classical and non-canonical NF- κ B pathways is observed in response to starvation. Starvation-induced NF- κ B activity is likely not without consequence however, as we find increased expression of anti-apoptotic and pro-survival NF- κ B target genes like cIAP2, Bnip3, and Bcl-xL in response to starvation (data not shown). NF- κ B-dependent expression of these genes could have important implications for balancing survival (autophagy) and death (apoptosis), a field that continues to remain under intense scrutiny (Levine and Yuan, 2005). Starvation-induced IKK activity therefore has multiple functions, first in controlling autophagy through regulation of autophagic gene expression and secondly by controlling an independent pathway leading to

activation of NF- κ B. It is likely that there are other key functions of IKK in regulating autophagy.

The role transcription factors play in regulating autophagy through gene expression changes is poorly understood. A recent report demonstrated that Skp2 expression, which inhibits autophagy, is controlled by non-canonical NF- κ B complexes in response to DNA damage (Barré and Perkins, 2010). The authors showed that NF- κ B plays an intricate role in coordinating autophagic and apoptotic pathways in response to various DNA damaging agents, which also required p53 activity. In addition, p53-dependent transcription of DRAM or TIGAR can directly activate or inhibit autophagy respectively, and cytoplasmic p53 inhibits autophagy by a transcription-independent mechanism (Bensaad *et al.*, 2009; Crighton *et al.*, 2006; Tasdemir *et al.*, 2008). E2F transcription factors influence autophagy through direct regulation of pro-autophagic genes DRAM, LC3 and ATG1, and by indirect regulation of ATG5 (Polager *et al.*, 2008). Interestingly, an emerging theme in the literature suggests that IKK/NF- κ B and E2F family transcription factors are involved in complex crosstalk. IKK and NF- κ B can regulate cell cycle by inhibiting E2F target gene transcription (Araki *et al.*, 2008). Furthermore, basal and hypoxia induced expression of the pro-autophagic gene BNIP3 is controlled through NF- κ B-dependent antagonism of E2F-1 in cardiomyocytes (Shaw *et al.*, 2008). Further investigation is necessary to determine how IKK/NF- κ B and E2F signaling pathways participate in cross-regulatory mechanisms to influence autophagy. In summary, we propose that IKK plays two roles in promoting survival in response to starvation. Firstly, IKK is required for a signaling-dependent mechanism that promotes autophagosome formation (Criollo *et al.*, 2009 and Figure 2.2A).

IKK-dependent control of LC3 expression supports this role by ensuring sufficient gene products for the machinery required for autophagosome formation. Secondly, under periods of extended starvation (12 hours), IKK activity is required to up-regulate autophagic components, likely to replace gene products that have been diminished by prolonged autophagy. Surprisingly, the requirement for IKK subunits in regulating gene expression does not occur through modulation of NF- κ B activity. Future studies should therefore identify IKK-dependent substrates important for the cell's response to nutrient deprivation in order to better understand how IKK controls mammalian autophagy.

2.4 Experimental Procedures

Cell Culture and Reagents

All mEFs were grown in DMEM (Sigma) supplemented with 10% Serum. Hank's Balanced Salt Solution (55021C) was from Sigma (St. Louis, MO 63103, USA).

Westernblotting Analysis and Antibodies Used

Whole cell extracts were prepared on ice with RIPA buffer supplemented with protease inhibitor mix (Roche, IN, USA) and phosphatase inhibitor mix (Sigma, MO, USA). Protein concentrations were determined by Bradford assay (Biorad Laboratories), 20-40 μ g of protein were loaded per sample. SDS-PAGE analysis was performed as previously described (Steinbrecher et al. 2005). Westernblotting was performed with Anti-I κ B α (phospho, 9246; total, 4812), p65 (phospho, 3033; total 4764), LC3 (3868), p100/p52 (4882) were from Cell Signaling Technology, Inc (Danvers, MA 01960, USA).

Electrophoretic Mobility Shift Assay (EMSA)

Nuclear extracts were prepared as previously described (Mayo et al. 1997) and used to analyze NF- κ B DNA binding with a consensus κ B oligonucleotide (E3292) from Promega (Madison, WI 53711, USA) as previously described (Steinbrecher et al. 2005). Supershift analysis was performed with Anti-p50 (7178) was from Santa Cruz (Santa Cruz, CA 95060, USA) and anti-p65 (3034) from Cell Signaling Technology.

Quantitative Realtime PCR

Total RNA extracts were obtained from cells by Trizol extraction (15596026; Invitrogen Carlsbad, CA 9200) extraction. Two micrograms of RNA was used for cDNA synthesis using random primers and Superscript II Reverse transcriptase (18064022; Invitrogen). Real-time PCR was performed and analyzed as previously described (Steinbrecher et al. 2005) with Taqman primer/probe gene expression assays from Applied Biosystems: NFKBIA (Mm00477798_m1), LC3 (Mm00458724_m1), BECN1 (Mm01265461_m1) ATG5 (Mm00504340_m1). Samples were normalized to GUSB expression, Mm03003537_m1 (Carlsbad, CA 92008, USA).

Acknowledgements

We are grateful to Dr. Alexander Hoffmann for the p65/c-Rel DKO cells and to Dr. Denis Guttridge for the RelB^{-/-} and p52^{-/-} cells. We thank members of the Baldwin lab for thoughtful discussion and manuscript feedback. Research support provided by NIH grants CA75080, AI035098 and the Waxman Cancer Research Foundation.

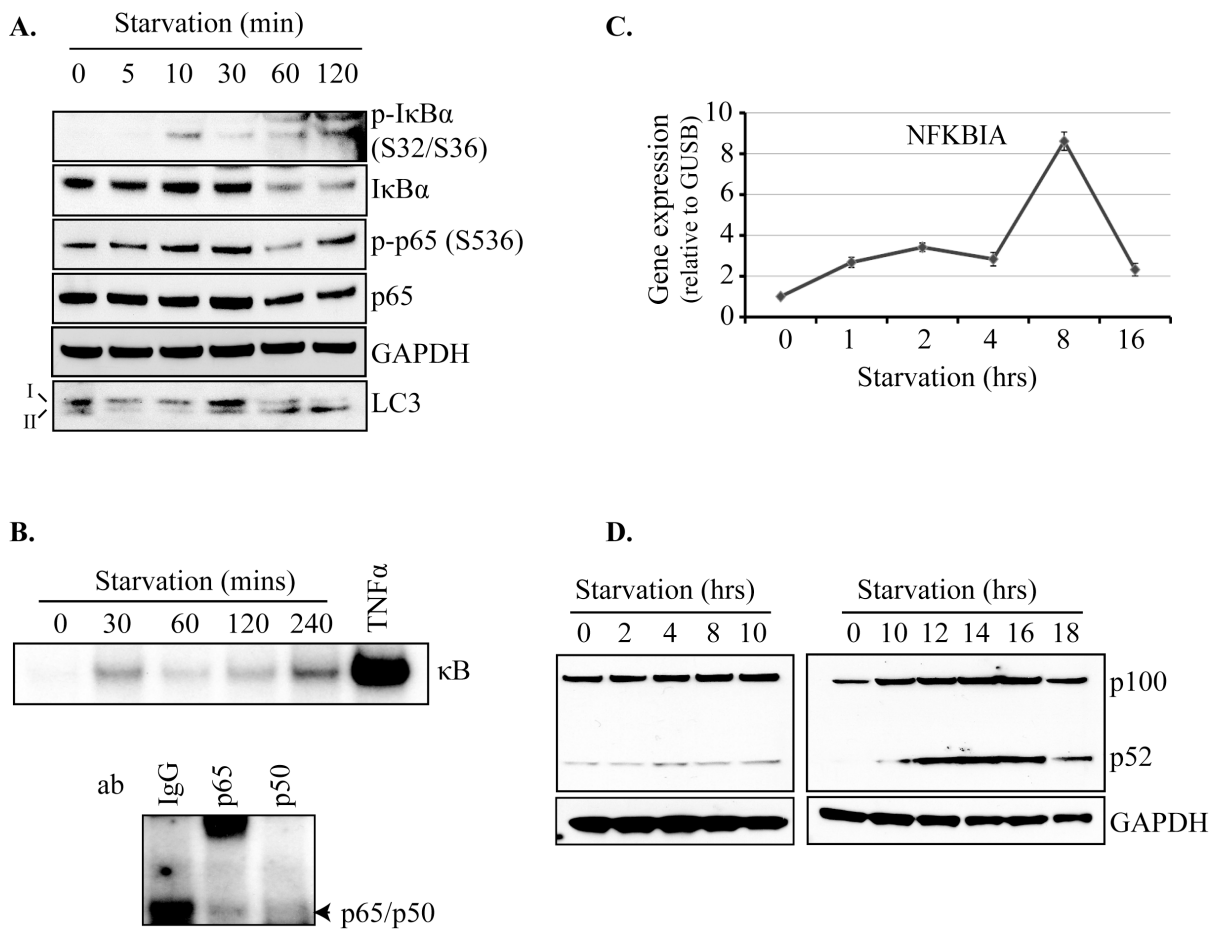

Figure 2.1 IKK/NF- κ B signaling is activated by nutrient stress

(A) Wildtype mouse embryonic fibroblasts (WT mEFs) were starved in Hanks' Balanced Salt Solution for a two-hour timecourse and cells were harvested at the indicated time points for whole cell lysates (WCL). WCL were subjected to westernblot analysis.

(B) Nuclear extracts were prepared for WT mEFs treated with a starvation timecourse for the indicated time points. NF- κ B DNA binding was assessed by EMSA using a consensus κ B oligonucleotide (upper panel). Nuclear extracts from WT mEFs starved for 240 minutes were used for supershift analysis of NF- κ B complexes using antibodies against p65 and p50.

(C) WT mEFs were starved for a 16-hour time course and total RNA was collected from cells at the indicated timepoints. Real Time PCR was used to assess the levels of the classic NF- κ B target gene NFKBIA

(D) WCLs were prepared from WT mEFs treated for starvation time course and activation of non-canonical NF- κ B was interrogated by processing of p100 to p52 by westernblot analysis.

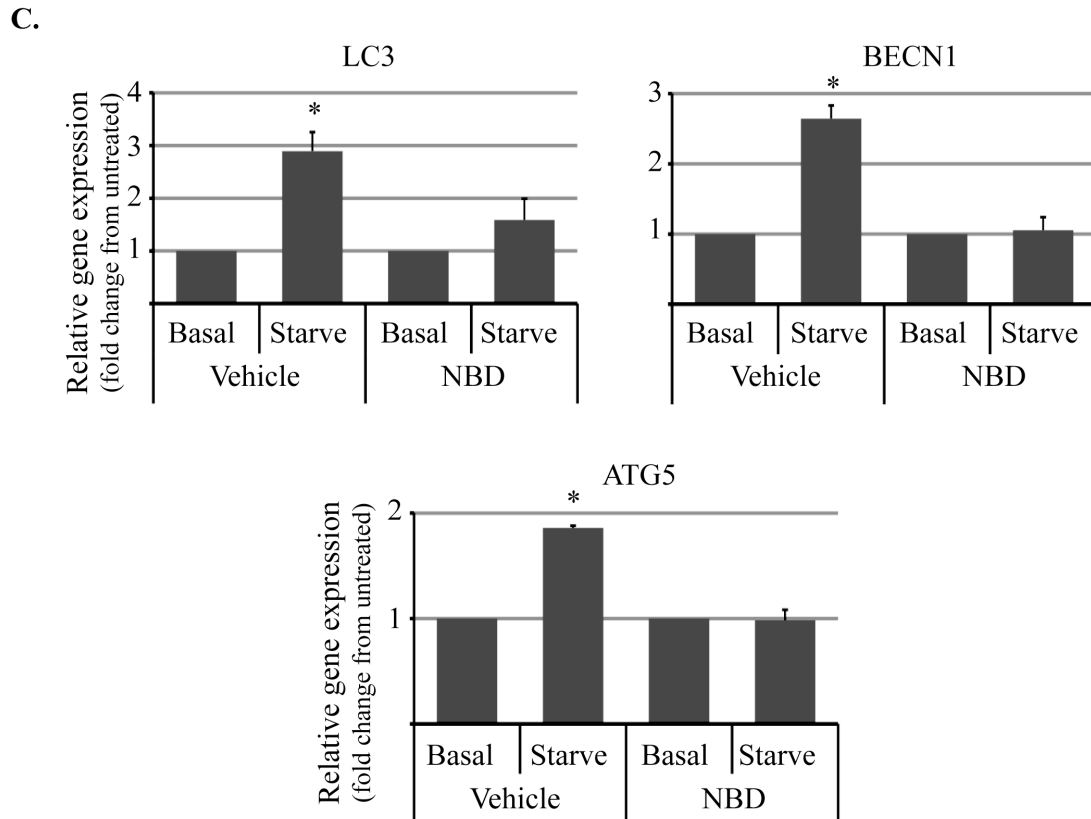
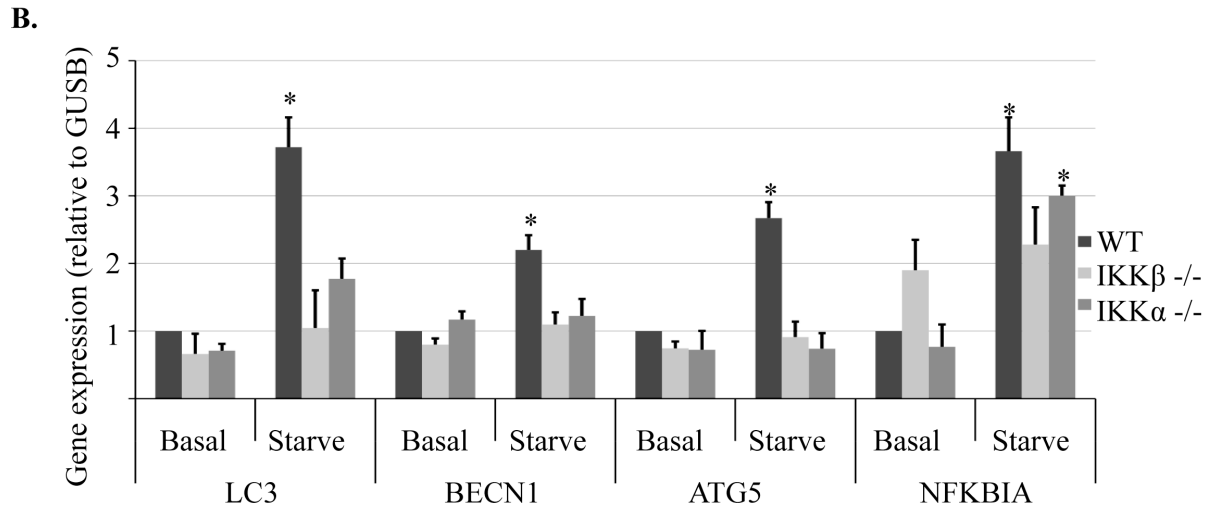
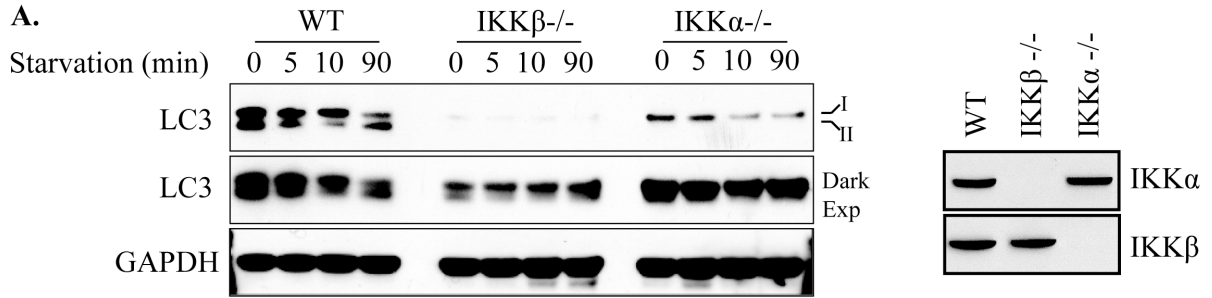

Figure 2.2 IKK is required for basal and starvation-induced expression of pro-autophagic genes

(A) WT or IKK deficient mEFs (IKK β $-/-$, IKK α $-/-$) were grown in basal or starvation media for 90 minutes and WCLs were prepared. Induction of autophagy was measured by LC3 processing.

(B) WT, IKK β $-/-$, and IKK α $-/-$ cells were grown in basal or starvation media for 12 hours, total RNA was collected for cDNA synthesis. Expression of LC3, ATG5, BECN1, and NFKBIA were measured using Taqman gene expression assays and normalized to GUSB expression. Statistically significant differences were measured by Student's t-test ($* < .05$).

(C) WT mEFs were treated with vehicle control or IKK inhibitor NEMO Binding Domain (NBD) peptide (100 μ M) 1 hour prior to starvation. Cells were then starved in the presence of NBD peptide or control for 12 hours. Gene expression was measured by Real Time PCR analysis. Data is represented as fold-change over expression of cells grown in basal media ($* < .05$).

A.

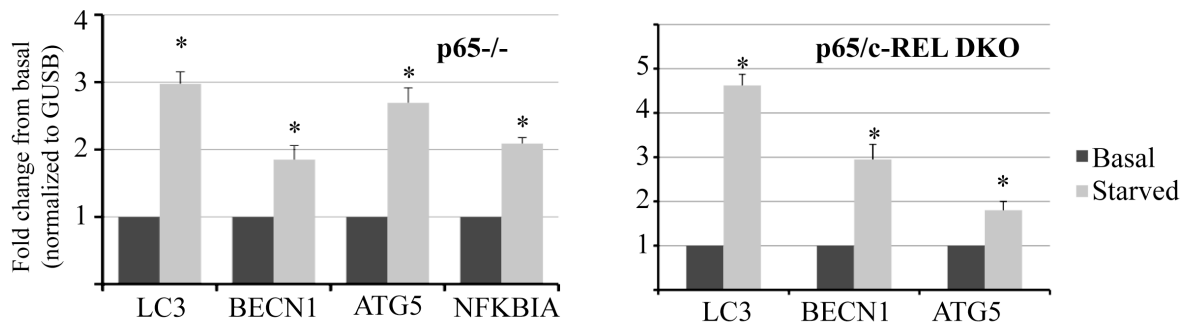

B.

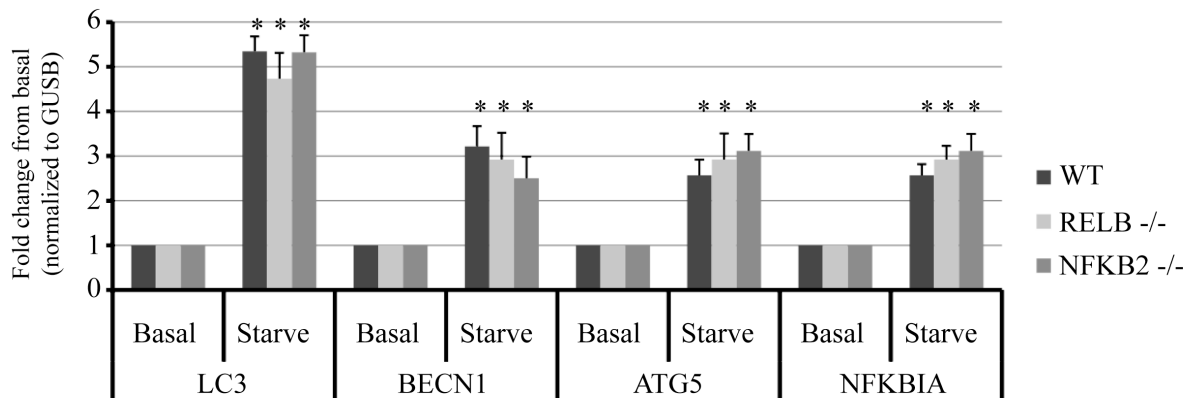

Figure 2.3 Basal and starvation-induced autophagic gene expression is NF- κ B-independent

(A) p65 null (p65 -/-), p65/c-Rel double null (p65/c-Rel DKO) mEFs were grown in basal or starvation media for 18 hours and pro-autophagic gene expression was measured

(B) WT, RelB, and NFKB2 null (RelB-/-, NFKB2-/-) mEFs were grown in basal or starvation media for 12 hours and pro-autophagic gene expression was measured. Data is represented as fold-change over basal expression, * $<.05$.

2.S1

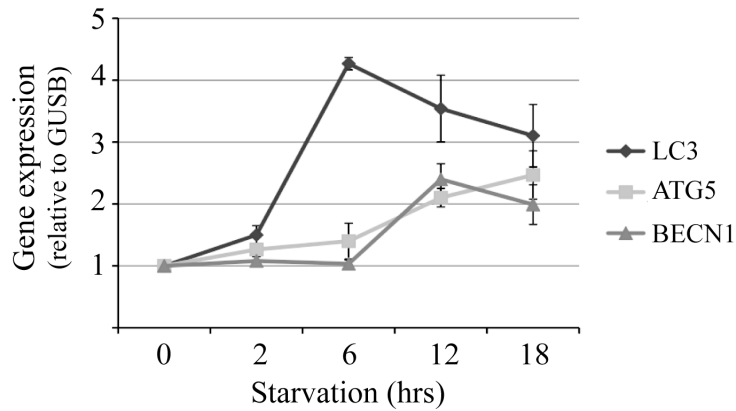

Figure 2.S1 Starvation induces increases in pro-autophagic gene expression

WT mEFs were starved for an 18-hour time course and total RNA was collected from cells at the indicated timepoints. Real Time PCR was used to assess expression of the LC3, ATG5, and BECN1 relative to GUSB expression.

2.S2

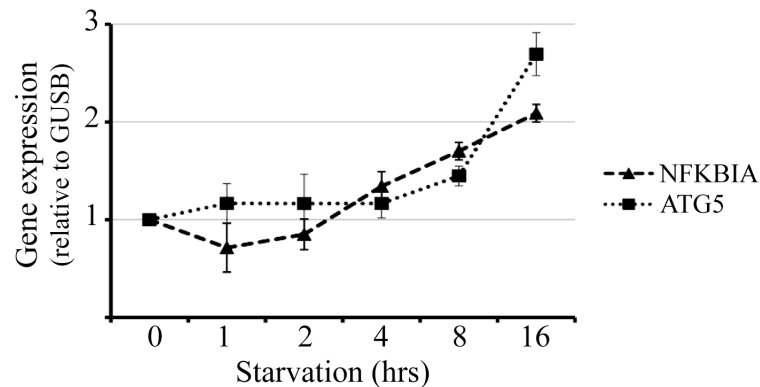

Figure 2.S2 p65 is required for starvation-induced NFKBIA expression

p65^{-/-} mEFs were starved for a 16-hour time course and total RNA was collected from cells at the indicated timepoints. Real Time PCR was used to assess expression of the classic NF- κ B target gene NFKBIA and autophagic gene ATG5 (expression normalized to GUSB levels).

REFERENCES

- Araki K, Kawauchi K, Tanaka N (2008). IKK/NF-kappaB signaling pathway inhibits cell-cycle progression by a novel Rb-independent suppression system for E2F transcription factors. *Oncogene* **27**: 5696-705.
- Barré B, Perkins N (2007). A cell cycle regulatory network controlling NF-kappaB subunit activity and function. *EMBO J* **26**: 4841-55.
- Barré B, Perkins ND (2010). The Skp2 Promoter Integrates Signaling through the NF-kappaB, p53, and Akt/GSK3beta Pathways to Regulate Autophagy and Apoptosis. *Mol Cell* **38**: 524-538.
- Bednarski BK, Baldwin AS, Kim HJ (2009). Addressing reported pro-apoptotic functions of NF-kappaB: targeted inhibition of canonical NF-kappaB enhances the apoptotic effects of doxorubicin. *PLoS ONE* **4**: e6992.
- Bensaad K, Cheung E, Vousden K (2009). Modulation of intracellular ROS levels by TIGAR controls autophagy. *EMBO J* **28**: 3015-26.
- Bubici C, Papa S, Dean K, Franzoso G (2006). Mutual cross-talk between reactive oxygen species and nuclear factor-kappa B: molecular basis and biological significance. *Oncogene* **25**: 6731-48.
- Comb, W. C., Cogswell, P., Sitcheran, R., & Baldwin, A. S. (2010). IKK-dependent, NF-κB-independent control of autophagic gene expression. *Oncogene*, **30**(14):, 1727-1732.
- Copetti T, Bertoli C, Dalla E, Demarchi F, Schneider C (2009). p65/RelA modulates BECN1 transcription and autophagy. *Mol Cell Biol* **29**: 2594-608.
- Crichton D, Wilkinson S, O'Prey J, Syed N, Smith P, Harrison PR *et al* (2006). DRAM, a p53-induced modulator of autophagy, is critical for apoptosis. *Cell* **126**: 121-34.
- Criollo A, Senovilla L, Authier H, Maiuri M, Morselli E, Vitale I *et al* (2009). The IKK complex contributes to the induction of autophagy. *EMBO J* **29**: 619-31.
- Djavaheri-Mergny M, Amelotti M, Mathieu J, Besançon F, Bauvy C, Souquère S *et al* (2006). NF-kappaB activation represses tumor necrosis factor-alpha-induced autophagy. *J Biol Chem* **281**: 30373-82.
- Gilmore T (2006). Introduction to NF-kappaB: players, pathways, perspectives. *Oncogene* **25**: 6680-4.

- Hacker H, Karin M (2006). Regulation and function of IKK and IKK-related kinases. *Sci STKE* **2006**: re13.
- Hayden MS, Ghosh S (2004). Signaling to NF-kappaB. *Genes Dev* **18**: 2195-224.
- Hoffmann A, Leung TH, Baltimore D (2003). Genetic analysis of NF-kappaB/Rel transcription factors defines functional specificities. *EMBO J* **22**: 5530-9.
- Klionsky DJ (2004). Cell biology: regulated self-cannibalism. *Nature* **431**: 31-2.
- Klionsky DJ, Abeliovich H, Agostinis P, Agrawal DK, Aliev G, Askew DS *et al* (2008). Guidelines for the use and interpretation of assays for monitoring autophagy in higher eukaryotes. *Autophagy* **4**: 151-75.
- Levine B, Kroemer G (2008). Autophagy in the pathogenesis of disease. *Cell* **132**: 27- 42.
- Levine B, Yuan J (2005). Autophagy in cell death: an innocent convict? *J Clin Invest* **115**: 2679-88.
- Lombardi L, Ciana P, Cappellini C, Trecca D, Guerrini L, Migliazza A *et al* (1995). Structural and functional characterization of the promoter regions of the NFKB2 gene. *Nucleic Acids Research* **23**: 2328-36.
- May MJ, D'Acquisto F, Madge LA, Glöckner J, Pober JS, Ghosh S (2000). Selective inhibition of NF-kappaB activation by a peptide that blocks the interaction of NEMO with the IkappaB kinase complex. *Science* **289**: 1550-4.
- Mayo M. W., C. Y. Wang, P. C. Cogswell, K. S. Rogers-Graham, S. W. Lowe, C. J. Der, and A. S. Baldwin, Jr. (1997). "Requirement of NF-kappaB activation to suppress p53-independent apoptosis induced by oncogenic Ras." *Science* **278** (5344):1812-5
- Polager S, Ofir M, Ginsberg D (2008). E2F1 regulates autophagy and the transcription of autophagy genes. *Oncogene* **27**: 4860-4.
- Renner F, Schmitz ML (2009). Autoregulatory feedback loops terminating the NF- kappaB response. *Trends Biochem Sci* **34**: 128-35.
- Saccani S, Pantano S, Natoli G (2001). Two waves of nuclear factor kappaB recruitment to target promoters. *J Exp Med* **193**: 1351-9.
- Shaw J, Yurkova N, Zhang T, Gang H, Aguilar F, Weidman D *et al* (2008). Antagonism of E2F-1 regulated Bnip3 transcription by NF- κ B is essential for basal cell survival. *Proc Natl Acad Sci USA* **105**: 20734-9.

Steinbrecher, K. A., W. Wilson, 3rd, P. C. Cogswell, and A. S. Baldwin. (2005). "Glycogen synthase kinase 3beta functions to specify gene-specific, NF-kappaB-dependent transcription." *Mol Cell Biol* **25** (19):8444-55

Tasdemir E, Maiuri MC, Galluzzi L, Vitale I, Djavaheri-Mergny M, D'amelio M *et al* (2008). Regulation of autophagy by cytoplasmic p53. *Nat Cell Biol* **10**: 676-87.

Ziegelbauer K, Gantner F, Lukacs NW, Berlin A, Fuchikami K, Niki T *et al* (2005). A selective novel low-molecular-weight inhibitor of IkappaB kinase-beta (IKK-beta) prevents pulmonary inflammation and shows broad anti-inflammatory activity. *Br J Pharmacol* **145**: 178-92.

Chapter Three

IKK PHOSPHORYLATES AND PROMOTES FEEDBACK INHIBITION OF PI3K IN RESPONSE TO NUTRIENT DEPRIVATION

3.1 Abstract

The cell's ability to respond to nutrient availability is dynamic and involves rapid changes in signal transduction pathways. In the presence of nutrients and growth factors the PI3K/AKT/mTOR signaling axis is activated to drive cellular metabolism and proliferation and inhibit stress programs such as autophagy. Nutrient depletion leads to downregulation of PI3K/Akt/mTOR signaling and induction of autophagy, a conserved cellular degradation program essential organismal adaptation to nutrient stress. Here we demonstrate through genetic and chemical means that the pro-inflammatory kinase IKK is required for starvation-induced feedback inhibition of PI3K activity. We identify the p85 regulatory subunit of PI3K as a novel IKK substrate phosphorylated at Ser690 *in vitro* and *in vivo* in response to nutrient starvation. Importantly, cells expressing p85 α S690A mutant display increased AKT/mTOR activity under periods of prolonged starvation. Serine-690 is found in a conserved region of the cSH2 domain and we find that IKK-mediated phosphorylation of p85 α results in decreased affinity for phospho-tyrosine residues on important adaptor molecules. Taken together these data suggest that nutrient deprivation promotes feedback inhibition of PI3K through a novel mechanism mediated by IKK-dependent phosphorylation and modulation of p85 SH2 domain function. Characterization of cross-talk between IKK/NF- κ B and PI3K/AKT is likely to have important implications for inflammation-associated pathologies such as obesity and tumorigenesis.

3.2 Introduction

The I κ B Kinase (IKK) complex has been extensively studied for its ability to activate NF- κ B transcription factors to promote inflammatory gene expression in response to a variety of cell stresses and signals. IKK negatively regulates a family of inhibitory molecules called Inhibitor of kappaB (I κ B), which under basal/unstimulated conditions bind NF- κ B dimers sequestering them to the cytosol (Gilmore 2006). In response to inflammatory cytokines such as TNF α , IKK which components include two catalytic subunits (IKK α and IKK β) and a regulatory subunit (NEMO/IKK γ), phosphorylates I κ B at two critical serines, promoting polyubiquitination and proteasome-dependent degradation (Häcker & Karin 2006). IKK-dependent phosphorylation of I κ B results in liberation of NF- κ B, nuclear translocation, target gene DNA binding and transcriptional regulation. Studies investigating IKK activity often focus on how such a diverse set of stimuli (eg. cytokines, DNA damage, chemokines, ER stress, and hypoxia) all distinctly activate IKK to elicit the NF- κ B-dependent pro-survival program.

Recently an unbiased small molecule screen identified a role for IKK in regulating stress-induced autophagy, and interestingly, this occurs independently of the ability to regulate NF- κ B (Criollo et al. 2009). Autophagy is a conserved cellular catabolic process important for energy homeostasis and cellular maintenance which is up-regulated in response stress like nutrient starvation. Autophagy results in breakdown of long-lived organelles and proteins whose constituent molecular building blocks get recycled to promote minimal metabolism in otherwise unsustainable conditions (Yorimitsu & Klionsky 2005). Criollo et al. demonstrated that cellular starvation, a classic autophagy-inducing stimulus is also a novel

IKK/NF- κ B-inducing stimulus, but that IKK-dependent activity on autophagy is uncoupled from NF- κ B activation. It is still unclear how IKK contributes to this process; henceforth starvation-induced IKK activity should be examined in order to understand NF- κ B-independent functions that promote cell survival and metabolism. We have previously demonstrated that IKK controls an autophagic gene expression program in response to starvation that is independent of NF- κ B transcriptional activation. Our data highlights the role of IKK as master regulator of gene expression in response to starvation, serving to activate anti-apoptotic NF- κ B target genes (cIAP2, Bcl-2), as well as an alternative NF- κ B-independent gene set that provides the cell with autophagic components (LC3, Beclin-1, Atg5) (Comb et al. 2010). This IKK-dependent role in promoting autophagy was examined following prolonged starvation (greater than 12 hours), and observations from our lab as well as those reported by Criollo, suggest that IKK also plays an immediate role in promoting autophagy initiation in response to very short periods of starvation. It therefore seems likely that a yet undescribed IKK-dependent mechanism is important for coordinating cellular metabolism downstream of metabolic stress.

Molecular dissection of the signaling pathways that regulate autophagy has focused on the major role of the PI3K/Akt/mTOR signaling network, an essential coordinator of cell growth and metabolism in response to nutrients and growth factors. TOR is a conserved serine/threonine kinase family member of PI3K-related Kinases (PIKKs) that coordinates metabolic activity and inhibits autophagy by sensing nutrients, oxygen, and stress (Sarbasov et al. 2005b). In all eukaryotes, mTOR interacts with a protein called Raptor to form a large nutrient sensitive kinase complex (mTORC1) and inhibit autophagy (Kim et al. 2002).

Inhibition of mTORC1 activity by nutrient depletion or pharmacologically with the naturally occurring antibiotic rapamycin, leads to induction of autophagy (Wang & Klionsky 2003). Higher eukaryotes have an extra level of control coordinated by growth factor-dependent activation of PI3K/Akt signaling which influences metabolism through feedback of FOXO transcription factors and by engaging mTOR activity (Manning & Cantley 2007). The major finding linking control of mTOR with growth factor-dependent signaling was the discovery that Akt directly phosphorylates and inhibits TSC2 a component of the TSC-1/TSC-2 tumor suppressor complex and critical negative regulator of mTOR (Manning et al. 2002; Inoki et al. 2002; Potter et al. 2002). In animal cells therefore, GF-dependent (eg: insulin) activation of PI3K/Akt results in a major metabolic program driving protein synthesis, cell growth, and inhibition of both apoptosis and autophagy.

Much of the complex signal transduction networks activated downstream of GF-dependent signaling is dependent upon activation of PI3K. PI3Ks are intracellular lipid kinases that phosphorylate the 3'-hydroxyl group of phosphoinositides involved in an array of biological processes from vesicle trafficking to cellular signaling. RTKs activate Class I PI3K molecules to phosphorylate phosphatidylinositol-4,5,-bisphosphate (PIP₂) generating phosphatidylinositol-3,4,5,-triphosphate (PIP₃) which recruit Pleckstrin homology (PH) and Phox homology (PX) domain containing proteins such as AKT to the plasma membrane (Cantley 2002). At the plasma membrane Akt is activated following a series of phosphorylation steps involving PDK-1-dependent phosphorylation of Threonine-308 and an mTOR-dependent phosphorylation at Serine-473 (Alessi et al. 1997; Sarbassov et al. 2005a). The finding that mTOR lies upstream of Akt comes as the functions of a second mTOR

containing complex (mTORC2), defined by interaction with the protein Rictor, are starting to be elucidated. Unlike mTORC1, mTORC2 activity is rapamycin- and nutrient-insensitive but activity can be increased by growth factors; mTORC2-dependent phosphorylation results in potentiation of Akt activity (Cybulski & Hall 2009).

Class 1A PI3K molecules are obligate heterodimers of regulatory p85 and catalytic p110 subunits and are activated in response to GF-dependent RTK stimulation (Engelman et al. 2006). p85 subunits are essential for PI3K activity but paradoxically loss of expression is associated with increased insulin sensitivity and overexpression leads to insulin resistance (Luo & Cantley 2005). Thus p85 regulatory subunits tightly control PI3K activity by both activating and inhibiting the p110 subunits, depending on the cellular context. Absent stimulus, p85 stabilizes and inhibits p110 activity; GF-dependent signaling of RTKs results in PI3K activation via association of p85 SH2 domains with tyrosine-phosphorylated residues on receptors and adaptor proteins. p85 SH2 phospho-tyrosine binding promotes PI3K activity by both properly localizing PI3K to the plasma membrane and by relieving p85 inhibitory effects resulting in increased lipid kinase activity (Yu et al. 1998). Downstream of PI3K activation are a number of important feedback mechanisms that highlight importance of restricting PI3K signaling; this notion is supported by the fact a great number of tumors are driven by oncogenic addiction to this pathway (Yuan & Cantley 2008).

In this study we have investigated novel signaling roles for IKK in response to cellular starvation, focused on control of the PI3K/Akt/mTOR pathway due to its importance in driving metabolic pathways in response to nutrients. We find that starvation-induced IKK activity is important for feedback inhibition of PI3K/Akt in response to cellular starvation.

We identify the p85 regulatory subunit of PI3K as a novel IKK substrate phosphorylated in response starvation and important for IKK-dependent feedback inhibition of growth factor-dependent signaling.

3.3 RESULTS

IKK promotes starvation-induced PI3K/Akt feedback inhibition

Cellular starvation is the most understood mechanism leading to activation of autophagy. Molecularly, cells must efficiently inhibit GF- and nutrient responsive signaling pathways in order to achieve maximal induction of autophagy in response to starvation. In order to assess mechanisms by which IKK promotes starvation-induced autophagy wildtype (WT) or IKK deficient (IKK β ^{-/-}, IKK α ^{-/-}) mouse embryonic fibroblasts (mEFs) were grown in starvation media (Hank's Balanced Salt Solution, HBSS) for very short (5-15 minutes) or extended (90 minutes) periods and feedback-inhibition of the PI3K/Akt/mTOR signaling effectors was monitored. Cells lacking IKK subunits displayed increased Akt activity under starvation conditions, but interestingly the requirement for IKK catalytic subunits appears to be distinct. Specifically, IKK β ^{-/-} mEFs displayed increased basal Akt phosphorylation, which resulted in slower kinetics of feedback inhibition while IKK α ^{-/-} mEFs demonstrated sustained Akt phosphorylation following both brief and extended starvation (Figure 3.1A). To ensure that the effects observed in the IKK null mEFs are dependent on IKK activity, WT mEFs were treated with the NEMO Binding Domain (NBD) peptide prior to starvation. The NBD peptide disrupts association between IKK catalytic and regulatory subunits inhibiting stimulus-induced-activity of both IKK α and IKK β (May et al. 2000). Consistent with data

from the null cell lines, IKK inhibition disrupted starvation-induced feedback inhibition of Akt activity. Notably, cells treated with the IKK inhibitor displayed a phenotype that reflected synergy between those observed in cells lacking single catalytic subunits (Figure 3.1B). Importantly, the requirement for IKK following 5-15 minutes of starvation correlates with the timeframe of IKK activation following starvation. Immunopurified IKK complexes from starved mEFs show maximal activity against a bacterially purified peptide substrate GST-I κ B(1-54) following 15 minutes of starvation returning to basal levels at following one hour of starvation (Figure 3.1C). Together, these data suggest that IKK activity induced in response to cellular starvation is important for inhibition of the PI3K pathway.

PI3K regulatory subunit p85 α is a putative IKK substrate

The rapidness with which starvation induced IKK activity and IKK-dependent PI3K feedback indicated that the effect of IKK was likely direct and occurring through modulation of an unknown substrate. To identify candidate IKK substrates which might regulate PI3K feedback inhibition, components of the PI3K/Akt signaling pathway were screened for amino acid sequence similarity with the published IKK β motif using scansite.org. This bioinformatic analysis identified Serine690 in the C-terminal SH2 domain of PI3K regulatory subunit p85 α as a very likely IKK phosphorylation site as the +3 acidic, +1 hydrophobic, and -2 aromatic correlate well with the published IKK β phosphorylation motif (Figure 3.2A) (Hutti et al. 2007). Considering that PI3K activity is important upstream of Akt activation and that Ser690 (and the surrounding IKK phosphorylation motif) are evolutionarily conserved (Figure 3.2B) p85 α was investigated as a novel IKK substrate. The ability of IKK

subunits to physically interact with p85 α was tested by co-expression of FLAG-p85 and either GST-IKK β or -IKK α in HEK293T cells. FLAG immune complexes were found to co-precipitate both IKK subunits (Figure 3.2C), demonstrating the basis for a functional interaction.

In order to determine if IKK catalytic subunits could directly phosphorylate p85 α an *in vitro* kinase assay was performed using GST-IKK β (Wildtype, WT or K44A kinase mutant, KA) purified from HEK293T cells. PI3K p85 family member p50 (which shares C-terminal portion of p85 α including the site analogous to p85 α S690) was purified from bacteria by GST pulldown and used as a substrate for recombinant IKK. Incubation of WT but not K44A mutant resulted in robust incorporation of radiolabeled 32-Phosphate into p50 (Figure 3.2D). In order to map the site of phosphorylation a cold IKK kinase assay was performed using GST-tagged fragment of p85 corresponding to the cSH2 domain, and the reaction was resolved by SDS-PAGE. The band corresponding to GST-cSH2 was excised from the gel, subjected to trypsin protease digestion, and analysis by mass spectrometry (microcapillary LC/MS/MS). A phosphopeptide consistent with phosphorylation at Ser690 was identified confirming the site predicted using bioinformatic analysis is phosphorylated by IKK *in vitro* (Figure 3.2E). Together, these results confirm that the p85 regulatory subunit of PI3K is phosphorylated *in vitro* by IKK at Ser690.

IKK phosphorylates p85 Serine690 in response to nutrient deprivation in vitro

A phospho-specific antibody was raised against p85 pS690 in order to investigate the role of IKK-dependent p85 phosphorylation in cells in culture. To validate the specificity of

this antibody WT or S690A mutant p85 was co-expressed with WT or K44A kinase mutant in HEK293T cells. p85 was immunoprecipitated with a FLAG antibody and immune complexes were blotted with the phospho-Ser690 antibody. Robust signal was observed when p85 and IKK were co-expressed but not in combinations containing either IKK K44A or p85 α S690A, indicating the antibody is highly specific for phosphorylated Ser690 (Figure 3.3A). The ability of IKK to phosphorylate endogenous p85 in response to starvation was next addressed by treating WT MEFs with starvation media in the presence or absence of the NBD peptide. Strong induction of Ser690 phosphorylation was observed in cells treated with vehicle control treated cells but cells treated with the IKK inhibitor (Figure 3.3B, lanes 1-4) or in cells lacking p85 α or both p85 α and p85 β (Figure 3.3B, lanes 5-8). The phospho-S690 specific antibody recognizes a non-specific band that co-purifies following immunoprecipitation of p85 from lysates prepared in 1% NP40 cell lysis buffers but not from those prepared under more stringent conditions (ie: RIPA buffer or sonication), explaining the presence of the band in Figure 3.3B and 3.5B but not in 3.3C or 3.3D.

The kinetics of starvation-induced p85 phosphorylation was next analyzed in comparison with markers of PI3K/Akt pathway activation status following a one hour timecourse of nutrient deprivation. Induction of p85 phosphorylation was inversely related to markers of PI3K downstream activation including Akt phosphorylation at Ser473 and phosphorylation of the S6K substrate ribosomal protein S6 (Ser235/236) indicating that activity both upstream (Akt) and downstream mTOR effector arm (S6) were inhibited as p85 phosphorylation is induced (Figure 3.3C). Inhibition of IKK with the NBD peptide both blocked starvation-induced p85 Ser690 phosphorylation and PI3K pathway feedback

inhibition confirming that both of these events are dependent on IKK activity (Figure 3.3D). The data above confirm IKK phosphorylates p85 *in vivo* in response to cellular starvation and this event corresponds with loss of PI3K/Akt signaling, both of which are dependent upon IKK activity.

p85 Ser690 phosphorylation is modulated in vivo in response to metabolic stress

Having demonstrated that incubation of cells in culture with nutrient depleted medium results in activation of a novel IKK-dependent pathway leading to phosphorylation and inhibition of PI3K/Akt activity it was next important to ask if this pathway was conserved in living organisms. In their analysis of IKK-dependent induction of autophagy, Criollo et al reported that liver extracts from fasted mice deficient for IKK β displayed sustained phosphorylation of the mTOR substrate S6K compared to WT controls (Criollo et al. 2009). This data suggests, and is consistent with findings presented herein, that IKK promotes feedback inhibition of the PI3K/Akt/mTOR signaling axis in response to nutrient deprivation. The relationship between fasting-induced PI3K feedback inhibition and p85 Serine690 phosphorylation was explored by fasting WT C57/B6 mice for 24 hours. p85 α Ser690 phosphorylation was increased in liver tissue from fasted animals compared to fed controls, however no changes in p85 S690 phosphorylation were detected in any other tissue analyzed (including skeletal muscle, kidney, spleen and heart) (Figure 3.4A and data not shown). Cell-based studies indicate that Serine690 phosphorylation is an early event in response to nutrient deprivation, as such p85 phosphorylation was explored in non-liver tissue in response to periods of acute fasting. Indeed, p85 phosphorylation was induced in

skeletal muscle, cardiac, and spleen extracts and this increase was again observed to coincide with loss of Akt downstream effector activity (Figure 3.4B). These results demonstrate that p85 PI3K phosphorylation occurs in a variety of tissues in response to metabolic restriction.

IKK-dependency on fasting-induced effects on the PI3K signaling network were next assessed *in vivo* by analyzing liver extracts from fed or fasted IKK β fl/fl animals previously injected with adenovirus (GFP or Cre) by tail-vein injection (tvi). Congruent with the cell-based studies, animals injected with adeno-cre displayed increased Akt phosphorylation following 12- and 24-hour fasting periods compared to adeno-gfp injected controls (Figure 3.4C). Loss of IKK-dependent p85 phosphorylation correlated with increased phospho-Akt and phospho-S6 in IKK β fl/fl animals injected with AdCre. Taken together these results indicate that IKK subunits are important *in vivo* for phosphorylation and feedback inhibition of PI3K/Akt signaling in response to whole body fasting.

Ser690 phosphorylation is required for IKK-dependent PI3K feedback inhibition by modulating SH2-phospho-tyrosine affinity

If IKK-dependent phosphorylation of p85 Ser690 is required for starvation-induced feedback inhibition of PI3K then S690A mutation should abrogate these effects. This hypothesis was tested by performing an ectopic expression experiment in Cos7 cells to determine the role of Ser690 in IKK-dependent PI3K inhibition. Overexpression of p85 WT and S690A resulted in decreased PI3K activity as measured by Akt S473 phosphorylation, consistent with the long-understood role of p85 inhibiting PI3K activity when overexpressed (Luo & Cantley 2005). Overexpression of p85 and IKK led to a further loss of PI3K activity

as measured by S473 phosphorylation, supporting the previous data demonstrating that IKK phosphorylation of p85 inhibits PI3K function (Figure 3.5A). Importantly, co-expression of IKK with S690A mutant led to a dramatic increase in Akt S473 phosphorylation, indicating that this site is important for the IKK-mediated effects on PI3K activity (Figure 3.5A). The importance of Ser690 in IKK-dependent PI3K feedback was next assessed in the context of the biological stimulus cellular starvation. Cos7 cells were transfected with WT or S690A p85 α and 24 hours later were untreated or starved for 1 hour, cells were harvested, and the level of Akt phosphorylation was measured. Mock or WT p85 α transfected cells starved for one hour displayed efficient inhibition of PI3K pathway as measured by pAkt S473. Expression of S690A mutant p85 α , however resulted in impaired starvation-induced PI3K feedback inhibition (Figure 3.5B). Taken together these data demonstrate that Serine690 is important for IKK-mediated and starvation-induced PI3K feedback inhibition.

The presence of Ser690 in a conserved region of the C-terminal SH2 domain led to the hypothesis that phosphorylation at this site could disrupt the ability of p85 to interact with tyrosine-phosphorylated proteins. To evaluate this hypothesis, the effect of Ser690 phosphorylation on SH2 function was assessed by performing an *in vitro* SH2/phosphotyrosine affinity experiment. Briefly, bacterially purified GST-p85-cSH2 peptide was incubated in the presence or absence of recombinant IKK in order to achieve maximal S690 phosphorylation *in vitro*. The SH2 domains were extensively washed then used to precipitate known phospho-tyrosine-dependent interacting proteins Myc-IRS1 and HA-Gab1 from transfected HEK293T cell lysates. As expected, the unphosphorylated cSH2 efficiently precipitates IRS-1, Gab-1, and other tyrosine phosphorylated proteins from lysates of

pervanadate treated cells. In contrast, IKK-dependent SH2 domain phosphorylation *in vitro* resulted in a markedly reduced affinity for phospho-tyrosine compared to the affinity of an unphosphorylated SH2 domain (Figure 3.6A).

The observation that IKK-dependent SH2 domain phosphorylation results in decreased phospho-tyrosine affinity *in vitro* led to the hypothesis that starvation-induced IKK-dependent PI3K phosphorylation may serve to actively remove PI3K from activated Tyr-phosphorylated RTKS and adaptors in the absence of appropriate nutrient levels. PI3K-pTYR pulldown experiments extensively described by and colleagues were used to analyze IKK-dependent effects on PI3K-pTYR interactions in starved cells (Engelman et al. 2005). WT and IKK deficient (IKK α /b DKO) mEFs were starved for 15 minutes and the ability of PI3K to co-precipitate tyrosine-phosphorylated proteins was measured. WT mEFs displayed decreased PI3K/p-TYR associations in response to nutrient starvation which supports the hypothesis that starvation-induced PI3K phosphorylation should result in loss of pTYR binding. Importantly, cells lacking IKK subunits displayed sustained pTYR binding under nutrient starvation, demonstrating that the loss of PI3K-pTYR associations are dependent on IKK activity in response to starvation (Figure 3.6B). These data point to a model where nutrient deprivation-induced IKK-dependent p85 phosphorylation disrupts association of PI3K and activated RTKs (model Figure 4.2), serving to actively and efficiently inhibit PI3K/Akt pro-growth pathway in response to loss of nutrients.

3.4 Discussion

The regulation and control of the IKK complex continues to be a widely studied area. Given the cardinal role IKK plays in coordinating stress-induced immune and inflammatory responses the focus of these studies often centers on IKK-dependent activation of the NF- κ B (Scheidereit 2006). Identification of IKK substrates therefore has mostly been limited to direct modulators of NF- κ B activity. However, the discovery that IKK is required for mammalian autophagy, independent of NF- κ B activation, suggests that IKK influences cellular function beyond simply controlling inflammatory transcription networks and highlights the need to identify novel IKK substrates that serve as nodes of crosstalk with signaling networks involved in regulating cellular metabolism.

The mechanism by which IKK promotes autophagy in response to starvation is not clear. Starvation induced autophagy often requires cessation of signaling through the PI3K/Akt pathway, but IKK influences on this pathway have not been investigated previously. This question was addressed by assaying Akt phosphorylation in starved cells lacking IKK activity (either genetically or pharmacologically). Cells lacking IKK subunits or treated with an IKK-specific inhibitor display persistent Akt activation under periods of starvation (Figure 3.1A and 3.1B). Moreover, IKK β also regulates fasting-induced PI3K feedback inhibition *in vivo* because liver extracts from animals lacking IKK β were observed to display increased phospho-Akt S473 compared to WT animals under periods of acute fasting (Figure 3.4C).

For the purpose of this study Akt Ser473 phosphorylation status is used as an indicator of Akt activity. Phosphorylation of S473 is controlled by mTORC2, following Akt localization to the membrane, and serves to potentiate activity (Hietakangas & Cohen 2007).

Therefore, since AKT S473 phosphorylation is considered to be controlled by membrane localization to PIP3 (from PI3K) rather than an increase in upstream mTORC2 catalytic activity, Ser473 phosphorylation serves as a better indicator of PI3K activity than it does mTORC2 activity (Huang & Manning 2009). Threonine-308 phosphorylation, a PDK-1 controlled event, is a better marker of Akt activation in response to growth factor stimulation; however, the nature of the system under investigation herein explores mechanisms that control basal cell growth in response to starvation, and as such the reagents available at the time of study are not sensitive enough to detect Thr308 phosphorylation in basally growing cells. Importantly, the use of 473 phosphorylation as a surrogate of Akt activity appears to track well with modulation of downstream Akt effector pathways; cells lacking IKK subunits which display increased phospho-Akt S473 also display increased Akt substrate phosphorylation of FOXO3a Thr32, GSK3 β Ser9, and persistent downstream signaling of mTORC1 as read by phosphorylation of S6 Ser235/236 (Figure 3.3D).

The contribution of individual IKK catalytic subunits in controlling PI3K feedback inhibition in response to nutrient deprivation is unclear. Both IKK α and IKK β are able to interact with and phosphorylate p85 α *in vitro* but cells lacking either of these subunits display slightly different phenotypes in response to starvation (Figure 3.2C, 3.S2, and 3.1B). Concordantly, WT cells treated with the NBD peptide, which inhibits canonical IKK activity, display a synergistic phenotype compared to individual knock-out cells lines (Figure 3.1B). Interestingly, loss of IKK β *in vivo* appeared to have a greater effect in response to fasting than it did in immortalized null MEFs, *in vivo* IKK β more closely resembled the role of IKK α in cultured cells. These subtleties suggest that canonical IKK complex, including both

IKK α and IKK β , is involved in PI3K feedback inhibition. This is consistent with previously published data demonstrating that loss of both IKK catalytic subunits results in earlier lethality and phenotypic presentation than is observed in single knock-out animals(Li et al. 2000).

Very little is understood regarding starvation-induced IKK activity except that it is rapidly induced, as increased activity is observed following just 15 minutes of nutrient depletion (Figure 3.1C). This result is in-line with our previous findings that starvation-induced NF- κ B DNA binding is maximal at 30 minutes as well those reported by Criollo demonstrating that IKK plays an early role in the initiation of autophagy (Comb et al. 2010; Criollo et al. 2009). Importantly, induction of IKK activity as measured by *in vitro* kinase assay corresponds perfectly with the kinetics of PI3K/Akt feedback in response to starvation in cultured cells (Figure 3.1A), indicating that the effect of IKK on feedback is likely direct. This is also the case *in vivo* in response to whole body fasting, as in most tissues analyzed phosphorylation of the novel IKK substrate p85 occurs following just six hours of food withdrawal (Figure 3.4B). The mechanism by which IKK is so quickly activated in response to nutrient deprivation is an important question, and completely unknown and a topic of current investigation.

In order to elucidate the mechanism by which IKK promotes PI3K feedback inhibition, a bioinformatic approach was then taken in order to identify putative IKK substrates in the PI3K pathway by scanning candidate target protein sequences for matches with the published IKK β consensus phosphorylation site. The PI3K Regulatory subunit p85 α was found to contain a strong consensus IKK phosphorylation motif in the C-terminal SH2

domain (Figure 3.2A). Given the obvious importance of PI3K upstream of Akt/mTOR activation, the significance of IKK-dependent p85 phosphorylation was explored. IKK catalytic subunits are able to interact with and phosphorylate p85 α *in vitro* (Figure 3.2C and 3.2D). Importantly, p85 Serine690 phosphorylation is induced in an IKK-dependent manner in response to cellular starvation (Figure 3.3A and B). Taken together these data validate that PI3K regulatory subunit p85 α is a bona fide IKK substrate. Starvation-induced p85 Ser690 phosphorylation inversely correlates with markers of PI3K/Akt pathway activation (such as pAkt and pS6) (Figure 3.3C) and mutation of Serine690 to an alanine abrogates IKK-mediated, or starvation-induced, PI3K feedback inhibition (Figure 3.5A and B). Whether or not Serine690 phosphorylation is exclusively responsible for the IKK-dependent PI3K feedback remains an open question. Cells lacking p85 display defects in starvation induced PI3K feedback but do not nearly phenocopy those observed with loss of IKK (Data not shown). This result would suggest that IKK activity functions beyond p85 Serine690 phosphorylation to control PI3K feedback. Given the poorly understood nature of this activity a further examination of IKK-dependent control of metabolism in response to starvation should be performed using bioinformatic as well chemical/genetic screens for suppressors of IKK-mediated autophagy.

Serine690 resides in a conserved region of the C-terminal SH2 domain where it is the first residue in the second alpha-helix (aB) which functions by stabilizing the series of beta-sheets that form the phospho-tyrosine binding pocket. The structure of an SH2 bound with a phospho-tyrosine peptide indicates that Ser690 is accessible as it faces outside of the phospho-tyrosine pocket. The hydroxyl side chain is in direct contact with the +3 acidic

reside in the next turn of the helix (Hoedemaeker et al. 1999). We hypothesized that phosphorylation of this site could disrupt the alpha-helix and potentially disrupt phosphotyrosine binding. This hypothesis was tested *in vitro* by assaying the effect of Ser690 phosphorylation on SH2 domain/pTYR affinity. Bacterially purified GST-SH2 that had been phosphorylated by IKK *in vitro* displayed a marked decrease in affinity for tyrosine-phosphorylated adaptors and proteins including Gab1 and IRS1 *in vitro* compared to the unphosphorylated SH2 domain (Figure 3.6A). This result led to the prediction that starvation-induced p85 phosphorylation disrupts association of PI3K with activated signaling scaffolds, effectively removing it from sites of activity. This hypothesis was tested by analyzing IKK-dependent effects on PI3K/p-Tyr binding in the presence or absence of nutrients. Cells lacking IKK subunits displayed prolonged pTyr binding under periods of starvation compared to WT cells, supporting with the notion that IKK is necessary to disrupt these associations. Increased p85-pTYR binding was associated with activated Akt signaling observed with IKK deficient cells, consistent with loss of PI3K feedback (Figure 3.6B). These results demonstrate a novel post-translational modification of p85 important for PI3K feedback in response to nutrient deprivation. The mechanism described herein suggests that cells actively and rapidly downregulate GF-dependent PI3K signaling in response to nutrient depletion.

The identification of PI3K regulatory subunit p85 as an important molecule for starvation-induced PI3K feedback inhibition is consistent with a number of previous studies that have also defined roles for p85 subunits in negatively regulating PI3K activity (Luo & Cantley 2005). Interestingly, mutations in p110 catalytic subunits are thought to be oncogenic

by abrogating the ability of p85 to negatively regulate activity (Zhao & Vogt 2008). Monomeric p85 has also been demonstrated to form sequestration complexes in response to insulin stimulation likely restricting phospho-tyrosine from PI3K p85/p110 dimers (Luo et al. 2005). Finally, p85 has been demonstrated to bind to and promote the activity of PTEN following stimulus-induced activation of PI3K as a means of feedback inhibition (Taniguchi et al. 2006). In each of these cases p85 serves a critical role in restricting PI3K activity absent or following stimulation. Keeping PI3K inactive in the absence of growth factors and nutrients would provide an important growth checkpoint for cells, restricting the networks that control growth in such unfavorable conditions. The pathway described in this manuscript emphasize that inhibition of PI3K following nutrient depletion is an active process controlled by canonical IKK activity.

Over time the ancient mTOR pathway responsible for cell size and growth in single celled eukaryotes fused with the PI3K/Akt pathway in order for hormones to control these processes in multi-system organisms. It is not surprising that inflammatory signaling networks converge on metabolic pathways in higher eukaryotes to influence growth in response to stress. Indeed, TNF α has been demonstrated to activate mTOR in an IKK β -dependent manner involving phosphorylation and inhibition of the upstream inhibitor TSC1 to control growth and angiogenic potential in a breast cancer model (Lee et al. 2007). Work from our lab has demonstrated that constitutive activation of Akt resulting from loss of PTEN in prostate tumors drives a physical association between IKK α and mTORC1 which is important for control of TOR substrate phosphorylation S6K and 4EBP1 (Dan et al. 2007). Conversely, TNF α and IKK and family members are essential inflammatory component that

promotes insulin resistance in response to high fat diet (Baker et al. 2011). These studies indicate that under pathological conditions chronic inflammatory signaling pathways converge with and modulate growth factor responsive pathways that control metabolism, but the role of inflammatory signaling in controlling these pathways under physiological conditions is less well studied. We report here that in response to nutrient depletion, IKK directly phosphorylates PI3K to inhibit activity and block cell growth and metabolism under periods of nutrient stress. Further understanding the mechanistic underpinnings of inflammatory and metabolic pathway intersections will be important to understand how cell stress influences cellular metabolic activity.

3.5 Experimental Procedures

Antibodies, Plasmids, and Reagents

Anti- phospho-Akt S473, total Akt, IKK β , GST, phospho-p85 S690, total p85, phospho-S6 S235/236, phospho-FOXO3a T32, p110 α , and phospho-tyrosine were obtained from Cell Signaling Technology (CST), Inc. Anti-IKK α was from Millipore, Myc and GAPDH from Santa Cruz, HA from Covance, and Flag (M2) was obtained from Sigma. GST-IKK β and α , FLAG-p85 α , HA-p110 α , HA-GST, GST-p50, GST-cSH2, HA-Gab1 and HA-Akt were generous gifts from the Cantley lab. Myc-IRS1 was obtained from Addgene (plasmid 11374) Site directed mutagenesis of FLAG-p85 α S690A was performed using a modification of the QuickChange Site-directed mutagenesis protocol (Stratagene).

Cell Culture, Transfections, Immunoprecipitations, and Westernblotting

All cells (Cos7, HEK293T, and WT mEFs) were grown in DMEM supplemented with 10% FBS. Cos7 and HEK293T cells obtained from ATCC and were transfected according to manufacturers protocol with FuGENE (Roche). Whole cell extracts were prepared on ice with RIPA buffer supplemented with protease inhibitor mix (Roche, IN, USA) and phosphatase inhibitor mix (Sigma, MO, USA). For immunoprecipitations and kinase assays cells were lysed in 50mM Tris (pH 7.5) 150 mM NaCl, 1% NP-40, 1mM EDTA, 1mM EGTA, 1mM 2-glycerophosphate, 1mM PMSF, and 1mM Sodium Orthovanadate as previously described (Hutti et al. 2007). Protein concentrations were determined by Bradford assay (Biorad Laboratories), 20-40µg of protein were loaded per sample.

Analysis of Phospho-S690 by westernblotting.

Phospho-p85 S690 antibody was generated by Cell Signaling Technology Inc. Analysis of phospho-S690 must be preformed by analyzing purified p85. Briefly, whole cell lysates can be prepared with either RIPA or 1%NP-40 buffer described above. Total p85 antibody (4292, Cell Signaling Technology, Inc.) (1:100) is used to IP PI3K from 250-500µg of lysate. NP-40 preparations display a non-specific band that co-migrates with phospho-p85 S690, which is eliminated in RIPA precipitates.

In vitro IKK kinase assay

Whole cell lysates were prepared on ice for 45 minutes in lysis buffer containing 20 mmol/L Tris (pH 8.0), 500 mM/L NaCl, 0.25% Triton X-100, 1 mM/L EDTA, 1 mM/L

EGTA, 1 mM/L DTT, 1x protease inhibitor (Roche Applied Science), caliculin and 1x phosphatase inhibitor cocktail (Sigma-Aldrich). Endogenous IKK complexes were immunoprecipitated with an antibody against NEMO (BD Biosciences) and an *in vitro* kinase assay was performed with GST-I κ B fragment (1-54) purified from bacteria and analyzed as previously described (Steinbrecher et al. 2005).

In vitro p85 and cSH2 phosphorylation with recombinant IKK

Recombinant IKK β was prepared from GST-IKK β transfected 293T cells and kinase buffer contained 50mM Tris (pH 7.5), 12mM MgCl₂, 1mM 2-glycerophosphate, 100 μ M ATP and 10 μ Ci- γ -³²Phosphate/reaction and were performed as previously described (Hutti et al. 2007). GST-p50 substrate was purified from bacteria by GST pulldown.

Animal Experiments

Mice were grown in a pathogen free facility according to the protocols established by the University of North Carolina Institutional Animal Care and Use Committee. WT c57/B6 (Jackson Labs) or IKK β fl/fl mice (Kind gift of Dr. Manolis Pasparakis) were fasted as previously described (Criollo et al. 2009). Adenoviral-GFP or -Cre (obtained from UNC Virus Core Facility) was injected by tail vein as previously described and animals recovered for 5 days (Akagi et al. 1997).

In vitro SH2 Affinity

GST-cSH2 domain was purified from bacteria by GST-pulldown as described previously (Hutti et al. 2004) and subjected to an *in vitro* kinase reaction in the presence or absence of Recombinant IKK β (prepared from transfected HEK293T) lysates. The kinase reaction was allowed to proceed for six hours and the reaction was spiked with new kinase every two hours in order to achieve maximal phosphorylation of the substrate. SH2 domains were then washed extensively and incubated with pervanadate treated HEK293T lysate expressing HA-Gab1 or Myc-IRS1 for 2 hours at 4deg. Samples were eluted with 2x sample buffer +DTT and analyzed by SDS-PAGE and western blotting.

In vivo PI3K-pTYR pulldowns

5 μ g of whole cell lysates were prepared with NP-40 lysis buffer and PI3K was immunopurified with an anti-body against endogenous p85 (CST 4292). Experimental design and analysis was performed as previously described (Engelman et al. 2005).

Acknowledgements

We thank Dr. Manolis Pasparakis for providing IKK β fl/fl mice, Dr. John Asara of the BIDMC Mass Spectrometry Core for performing mass spectrometry, and LeShara Fulton for technical assistance. We are grateful to Dr. Jeff Engleman and members of the Bladwin Lab for helpful discussions. Research support is provided by NIH grants CA75080 (A.S.B), AI35098 (A.S.B), CA73756 (A.S.B), and R01 GM041890-21 (L.C.C).

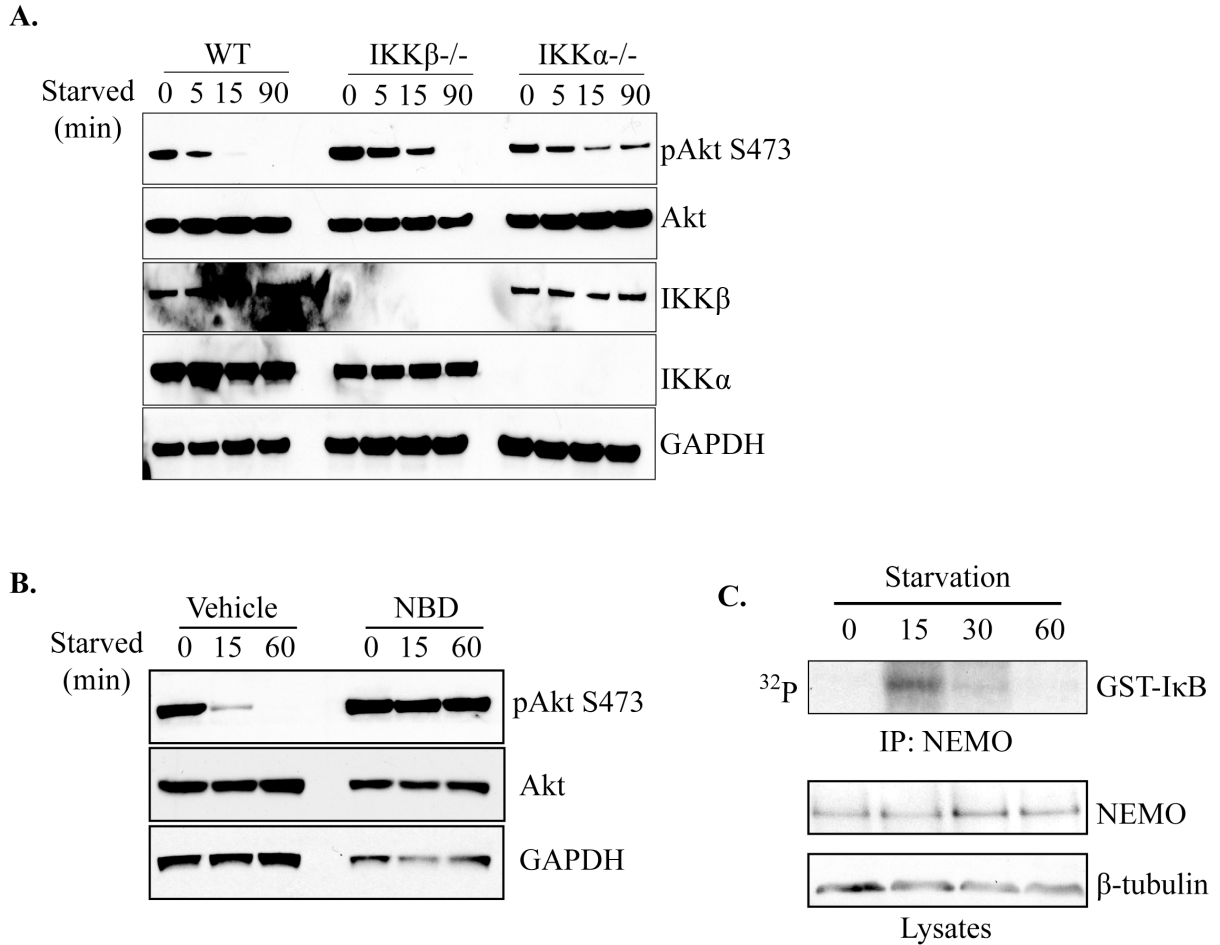

Figure 3.1 IKK is required for starvation-induced feedback inhibition of Akt

A. WT, IKK β ^{-/-}, and IKK α ^{-/-} mouse embryonic fibroblasts (mEFs) were grown in starvation media (Hank's Balanced Salt Solution; HBSS) for the indicated timepoint and whole cell extracts were harvested for western blot analysis.

B. WT mEFs were treated with vehicle control or 200 μ M NEMO Binding Domain (NBD) peptide for 1 hour prior to starvation time course. Cells were harvested for WCEs and western blot analysis.

C. WT mEFs were treated with starvation media for a 1hr timecourse. IKK was immunopurified with an antibody against NEMO and used in an *in vitro* kinase assay.

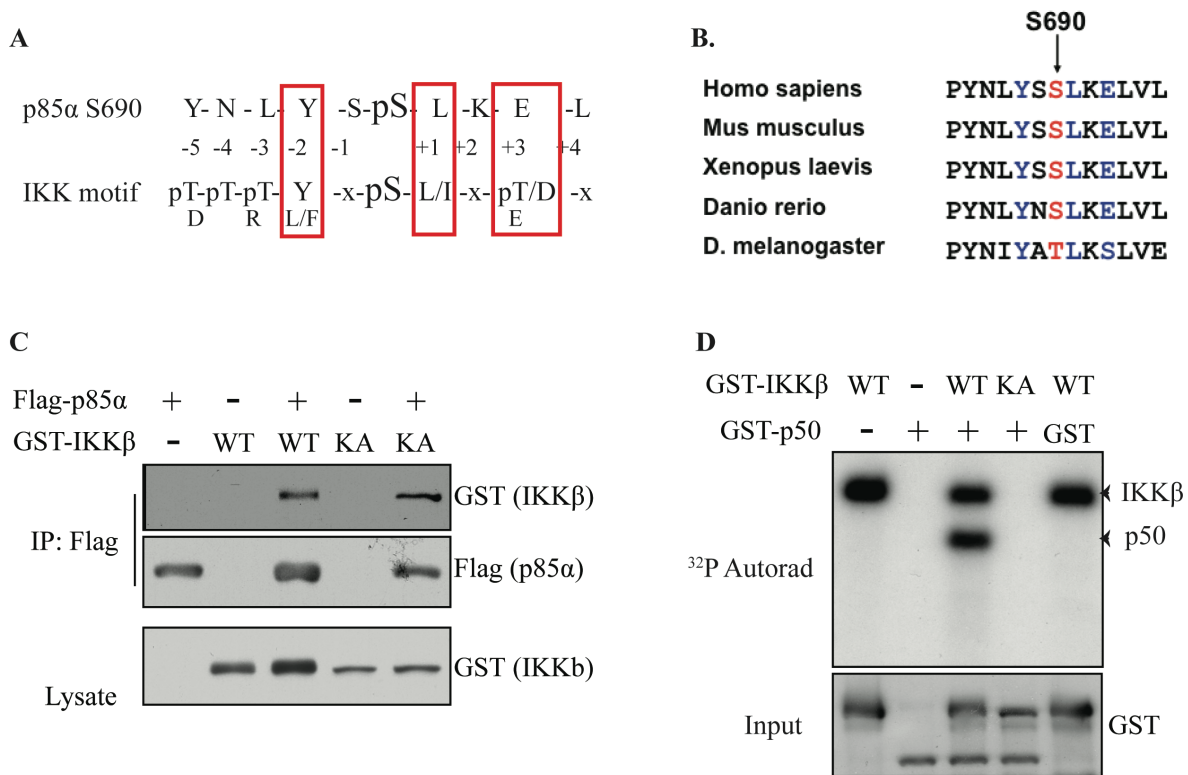

Figure 3.2 PI3K regulatory subunit p85α is a putative IKK substrate

A. Alignment of p85α Ser690 with IKK preferred substrate phosphorylation motif.

B. Evolutionary conservation of p85α Ser690 (red) and IKK motif (blue).

C. 293 cells were co-transfected with FLAG-p85α (WT or S690A) and GST-IKKα (WT or KA) as indicated. Flag immunoprecipitates were analyzed with phospho-Ser690 specific antibody.

D. Bacterial purified GST-p85 C-terminal fragment (p50) containing cSH2 and S690 was incubated with recombinant IKKβ (Wildtype, WT; Kinase Mutant, KA) as indicated. Kinase reactions were analyzed for incorporated radiolabeled 32P.

E. Mass spectra from in vitro IKK kinase reaction with p85-SH2 substrate. Recovered phosphorylated tryptic peptide fragment corresponding to Ser690 is indicated.

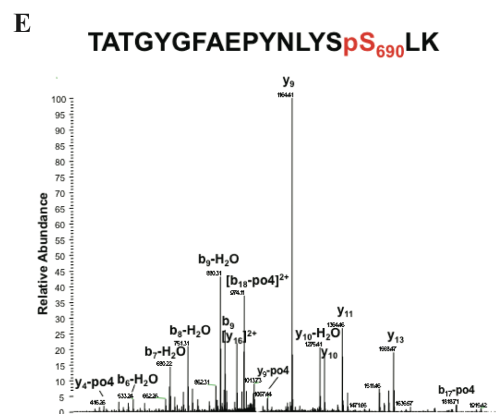

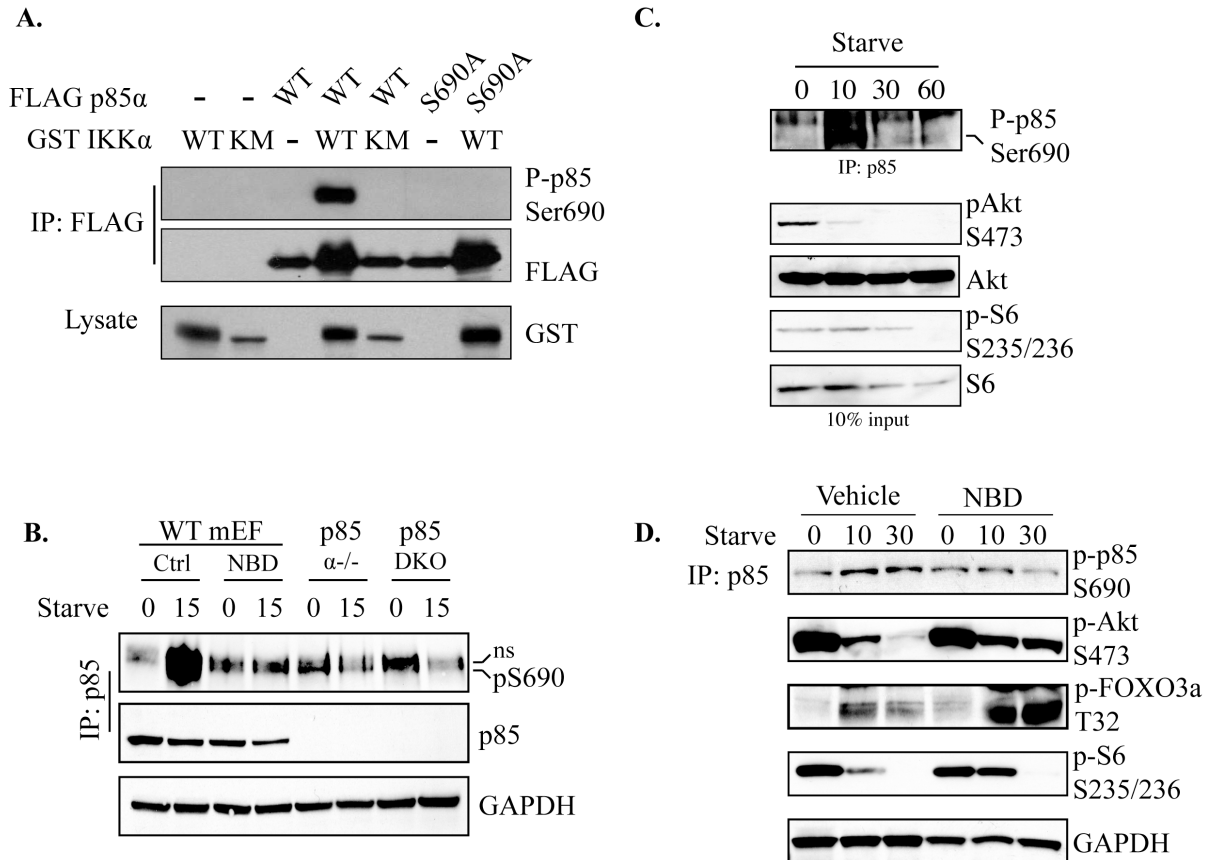

Figure 3.3 IKK-mediated Ser690 phosphorylation *in vitro* and *in vivo*

- A. 293 cells were co-transfected with FLAG-p85 α (WT or S690A) and GST-IKK α (WT or K45M, kinase mutant KM) as indicated. Flag immunoprecipitates were analyzed with phospho-Ser690 specific antibody.
- B. WT mEFs pretreated in absence or presence of NBD peptide (lanes 1-4), p85 α null (5-6), or p85 α / β double knock out cells (7-8) were left untreated or starved for 10 minutes. p85 immunoprecipitates were analyzed for phosphorylated Ser690.
- C. WT mEFs were starved for the indicated timepoints and p85 immunoprecipitates were analyzed for phosphorylated Ser690. Western blot analysis was performed with whole cell extracts for each sample.
- D. WT mEFs were pretreated with vehicle control or NBD peptide for 1 hour prior to starvation. Cells were starved for 30 or 60 minutes and whole cell extracts were analyzed by western blot.

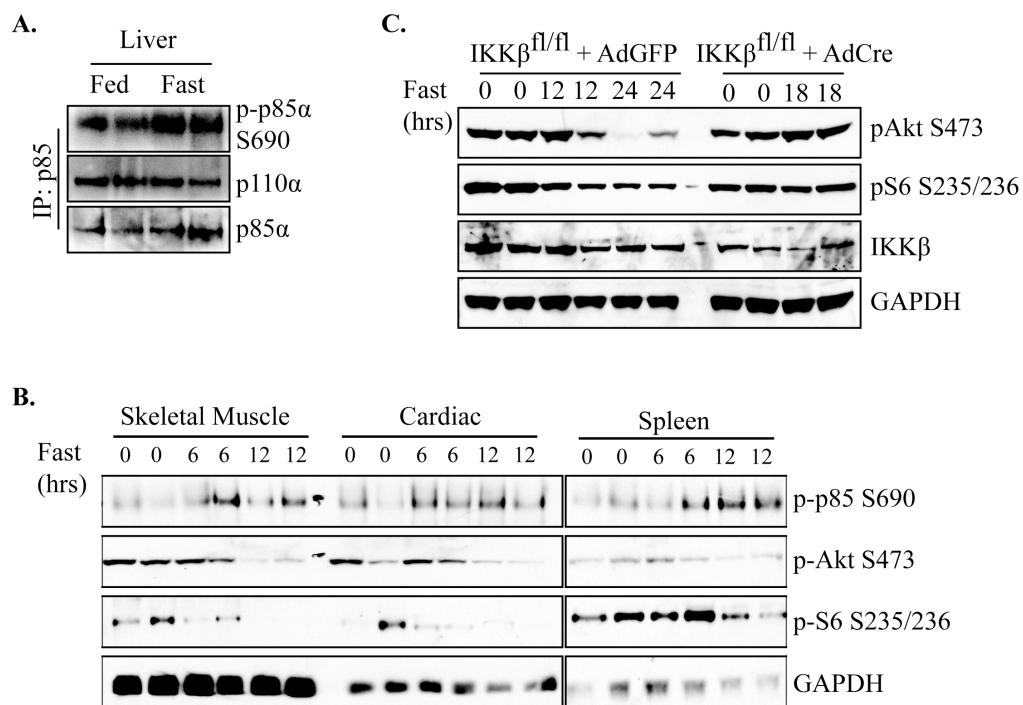

Figure 3.4 IKK-dependent Ser690 phosphorylation occurs in vivo in response to whole body fasting and correlates with PI3K/Akt feedback.

A. C57/B6 WT mice were fed or fasted for 24 hours livers were harvested for analysis of p85 phosphorylation as previous. Westernblot analysis of PI3K immunoprecipitates were performed with indicated antibodies.

B. C57/B6 WT mice were fed or fasted for short periods (6 and 12 hours). Animals were sacrificed and the indicated organs were harvested for analysis of PI3K/Akt pathway markers.

C. IKKβ fl/fl mice were injected with Adenovirus encoding GFP or Cre (AdGFP, AdCre). One week later animals were fed or fasted for 12 and 24 hours. Liver extracts were prepared and analyzed as in A and B.

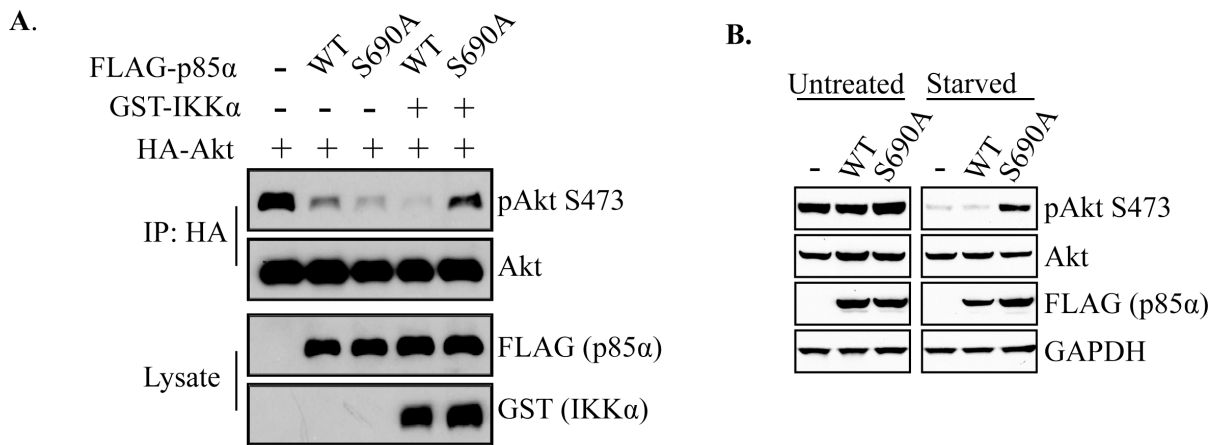

Figure 3.5 Ser690 is required for IKK-mediated and starvation-induced PI3K feedback inhibition

A. Cos7 cells were transfected with WT or S690A p85 α , IKK, and Akt. HA-Akt immunoprecipitates were analyzed for Ser473 phosphorylation.

B. Cos7 were transfected with WT or S690A p85 α . 48 hours following cells were left untreated or starved for 1 hour. Whole cell extracts were analyzed by western blotting

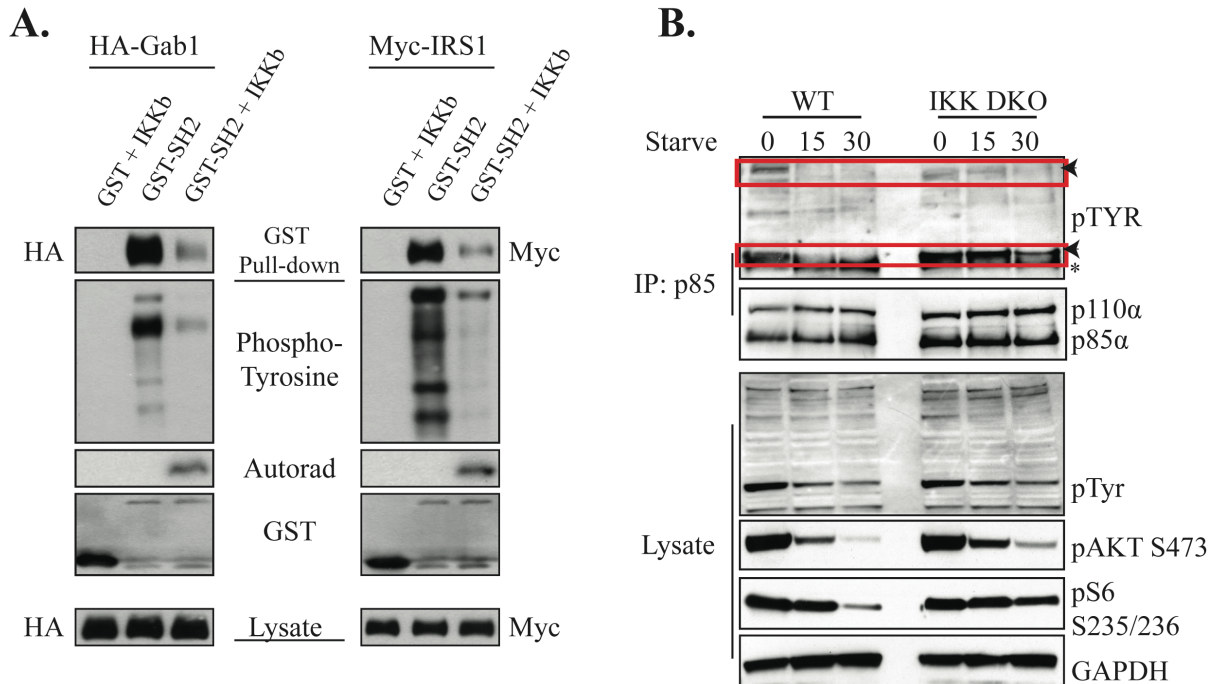

Figure 3.6 Ser690 phosphorylation disrupts p85-phospho-tyrosine binding

A. GST-cSH2 fragments were incubated in presence or absence of recombinant IKK β and intrinsic phospho-tyrosine affinity was assessed using lysates prepared from prevanadate treated 293 cells expressing either HA-Gab1 or Myc-IRS1.

B. IKK WT or DKO cells were starved for the indicated time points and p85 immunoprecipitates were analyzed for phospho-tyrosine binding. Whole cell lysates were analyzed by western blotting.

REFERENCES

- Akagi, K. et al., 1997. Cre-mediated somatic site-specific recombination in mice. *Nucleic Acids Research*, 25(9), pp.1766-1773.
- Alessi, D.R. et al., 1997. Characterization of a 3-phosphoinositide-dependent protein kinase which phosphorylates and activates protein kinase B α . *Current biology : CB*, 7(4), pp.261-269.
- Baker, R.G., Hayden, M.S. & Ghosh, S., 2011. NF- κ B, inflammation, and metabolic disease. *Cell metabolism*, 13(1), pp.11-22.
- Cantley, Lewis C, 2002. The phosphoinositide 3-kinase pathway. *Science (New York, NY)*, 296 (5573), pp.1655-1657.
- Comb, W.C. et al., 2010. IKK-dependent, NF- κ B-independent control of autophagic gene expression. *Oncogene*, 30(14), pp.1727-1732.
- Criollo, A. et al., 2009. The IKK complex contributes to the induction of autophagy. *The EMBO Journal*.
- Cybulski, N. & Hall, M.N., 2009. TOR complex 2: a signaling pathway of its own. *Trends in biochemical sciences*, 34(12), pp.620-627.
- Dan, H.C., Adli, M. & Baldwin, A.S., 2007. Regulation of mammalian target of rapamycin activity in PTEN-inactive prostate cancer cells by I kappa B kinase alpha. *Cancer Research*, 67(13), pp.6263-6269.
- Engelman, J.A. et al., 2005. ErbB-3 mediates phosphoinositide 3-kinase activity in gefitinib-sensitive non-small cell lung cancer cell lines. *Proceedings of the National Academy of Sciences of the United States of America*, 102(10), pp.3788-3793.
- Engelman, J.A., Luo, J. & Cantley, L.C., 2006. The evolution of phosphatidylinositol 3-kinases as regulators of growth and metabolism. *Nature Reviews Genetics*, 7(8), pp. 606-619.
- Gilmore, T.D., 2006. Introduction to NF- κ B: players, pathways, perspectives. *Oncogene*, 5 (51), pp.6680-6684.
- Häcker, H. & Karin, M., 2006. Regulation and function of IKK and IKK-related kinases. *Science's STKE : signal transduction knowledge environment*, 2006(357), p.re13.

- Hietakangas, V. & Cohen, S.M., 2007. Re-evaluating AKT regulation: role of TOR complex 2 in tissue growth. *Genes & Development*, 21(6), pp.632-637.
- Hoedemaeker, F.J. et al., 1999. Crystal structure of the C-terminal SH2 domain of the p85alpha regulatory subunit of phosphoinositide 3-kinase: an SH2 domain mimicking its own substrate. *Journal of Molecular Biology*, 292(4), pp.763-770.
- Huang, J. & Manning, B.D., 2009. A complex interplay between Akt, TSC2 and the two mTOR complexes. *Biochemical Society transactions*, 37(Pt 1), pp.217-222.
- Hutti, J.E. et al., 2004. A rapid method for determining protein kinase phosphorylation specificity. *Nature methods*, 1(1), pp.27-29.
- Hutti, J.E. et al., 2007. IkappaB kinase beta phosphorylates the K63 deubiquitinase A20 to cause feedback inhibition of the NF-kappaB pathway. *Molecular and Cellular Biology*, 27(21), pp.7451-7461.
- Inoki, K. et al., 2002. TSC2 is phosphorylated and inhibited by Akt and suppresses mTOR signalling. *Nature Cell Biology*, 4(9), pp.648-657.
- Kim, D. et al., 2002. mTOR interacts with raptor to form a nutrient-sensitive complex that signals to the cell growth machinery. *Cell*, 110(2), pp.163-175.
- Lee, D. et al., 2007. IKK beta suppression of TSC1 links inflammation and tumor angiogenesis via the mTOR pathway. *Cell*, 130(3), pp.440-455.
- Li, Q. et al., 2000. Complete lack of NF-kappaB activity in IKK1 and IKK2 double-deficient mice: additional defect in neurulation. *Genes & Development*, 14(14), pp.1729-1733.
- Luo, J. & Cantley, Lewis C, 2005. The negative regulation of phosphoinositide 3-kinase signaling by p85 and its implication in cancer. *Cell cycle (Georgetown, Tex)*, 4(10), pp.1309-1312.
- Luo, J. et al., 2005. The p85 regulatory subunit of phosphoinositide 3-kinase down-regulates IRS-1 signaling via the formation of a sequestration complex. *The Journal of Cell Biology*, 170(3), pp.455-464.
- Manning, B.D. & Cantley, Lewis C, 2007. AKT/PKB signaling: navigating downstream. *Cell*, 129(7), pp.1261-1274.
- Manning, B.D. et al., 2002. Identification of the tuberous sclerosis complex-2 tumor suppressor gene product tuberlin as a target of the phosphoinositide 3-kinase/akt pathway. *Molecular Cell*, 10(1), pp.151-162.

- May, M.J. et al., 2000. Selective inhibition of NF-kappaB activation by a peptide that blocks the interaction of NEMO with the IkappaB kinase complex. *Science (New York, NY)*, 289(5484), pp.1550-1554.
- Potter, C.J., Pedraza, L.G. & Xu, T., 2002. Akt regulates growth by directly phosphorylating Tsc2. *Nature Cell Biology*, 4(9), pp.658-665.
- Sarbassov, D D et al., 2005a. Phosphorylation and regulation of Akt/PKB by the rictor-mTOR complex. *Science (New York, NY)*, 307(5712), pp.1098-1101.
- Sarbassov, Dos D, Ali, S.M. & Sabatini, D.M., 2005b. Growing roles for the mTOR pathway. *Current Opinion in Cell Biology*, 17(6), pp.596-603.
- Scheidereit, C., 2006. IkappaB kinase complexes: gateways to NF-kappaB activation and transcription. *Oncogene*, 25(51), pp.6685-6705.
- Steinbrecher, K.A. et al., 2005. Glycogen synthase kinase 3beta functions to specify gene-specific, NF-kappaB-dependent transcription. *Molecular and Cellular Biology*, 25(19), pp.8444-8455.
- Taniguchi, C.M. et al., 2006. Phosphoinositide 3-kinase regulatory subunit p85alpha suppresses insulin action via positive regulation of PTEN. *Proceedings of the National Academy of Sciences of the United States of America*, 103(32), pp. 12093-12097.
- Wang, C. & Klionsky, Daniel J, 2003. The molecular mechanism of autophagy. *Molecular medicine (Cambridge, Mass)*, 9(3-4), pp.65-76.
- Yorimitsu, T. & Klionsky, D J, 2005. Autophagy: molecular machinery for self-eating. *Cell Death and Differentiation*, 12 Suppl 2, pp.1542-1552.
- Yu, J., Wjasow, C. & Backer, J.M., 1998. Regulation of the p85/p110alpha phosphatidylinositol 3'-kinase. Distinct roles for the n-terminal and c-terminal SH2 domains. *The Journal of biological chemistry*, 273(46), pp.30199-30203.
- Yuan, T.L. & Cantley, L C, 2008. PI3K pathway alterations in cancer: variations on a theme. *Oncogene*, 27(41), pp.5497-5510.
- Zhao, L. & Vogt, P.K., 2008. Class I PI3K in oncogenic cellular transformation. *Oncogene*, 27(41), pp.5486-5496.

Chapter Four

CONCLUSIONS

4.1 Summary

The cell's ability to sense and cope with stress is quite extraordinary. Cells integrate a steady milieu of hormones, nutrients, and cytokines in order to maintain homeostasis. Each of these extracellular cues coordinates a specific transduction program which typically converges on the nucleus for changes in gene expression and maintain homeostasis. Local or systemic insults result in changes to these inputs, alterations in signal transduction networks, and ultimate convergence on the nucleus where master regulators of gene expression direct a cell to grow, divide, die, or arrest. Mis-integration of any of these programs can result in the premature death or over proliferation of cells, which is often the underlying cause of human disease. Recent system-level approaches to understand the networks that control these cellular responses have uncovered a complicated and dense web of signal transduction. As molecular biologists we strive to limit variables and simplify systems in order to understand the basic principles governing such a complex coordination of biological processes. We've made great progress understanding the molecular networks that coordinate transduction of one particular signal, for example how a cytokine induces an inflammatory response, or how a nutrient induces a metabolic change. However, understanding the interplay of these pathways has proven to be more challenging.

In the work described in Chapters 3 and 4, we have attempted to combine molecular, biochemical, and bioinformatic approaches to understand a novel role for the I κ B Kinase, an important molecule involved in transducing stress signals in higher eukaryotes, in regulating an ancient survival pathway, autophagy, which is conserved from human to yeast. IKK has long been considered a pro-survival factor for its ability to induce NF- κ B transcription

factors in response to cell stress. The finding that IKK promotes autophagy as a cell survival mechanism independent from the ability to regulate NF- κ B is provocative, but the mechanism by which IKK promotes this activity was not understood. In the preceding text two novel roles for IKK in promoting the cellular response to the classic autophagy inducing stimulus cellular starvation were described (Comb et al. 2010) (and Comb, Hutti, et al - manuscript in preparation.).

In order to understand the role of IKK in controlling autophagy the classic stimulus nutrient deprivation was explored as a novel IKK/NF- κ B inducing stress. We found that cellular starvation rapidly induces activity of the inflammatory signaling pathway IKK/NF- κ B following just 15 minutes of growing cells in nutrient depleted media as measured by classic biochemical approaches like IKK *in vitro* kinase assays and NF- κ B DNA binding assays (see Figure 3.1 and 2.1). We found that cellular starvation induced expression of classical NF- κ B target genes such as *NFKBIA* and *BCL2* which indicated that indeed starvation induces canonical NF- κ B activity. Using a bioinformatic and candidate approach we searched for novel IKK/NF- κ B-dependent genes that were regulated in response to starvation in order to better understand how this pathway may be involved in regulating autophagy. We found a set of genes involved in promoting autophagy were induced in an IKK-dependent manner in response to starvation, and even though the promoters of these genes contained putative κ B elements, NF- κ B was not involved in regulating the expression of these genes (Figure 2.2 and 2.3). The finding that IKK-dependent control of autophagic gene expression does not involve NF- κ B was consistent with the findings of Criollo (2009), but surprising nonetheless.

This work identified that IKK controls two important gene expression programs in response to cellular starvation, involving both canonical NF- κ B anti-apoptotic genes as well as an NF- κ B-independent program that promotes autophagy (Figure 4.1). The question of how IKK promotes transcriptional control of autophagic gene expression is still unanswered and should be the focus of future studies (see below). IKK-dependent control of autophagic gene expression describes a novel mechanism by which IKK could support starvation-induced autophagy but it was clear the function extended beyond this activity. Evidence from our lab and presented by Criollo suggested that immediate activation of IKK served a function toward coordinating signaling events that promote autophagosome formation. While starvation-induced expression of autophagic genes would certainly promote autophagosome production over prolonged starvation, no significant differences in expression of these gene products following acute starvation. Therefore we hypothesized the IKK played a direct signaling role to promote autophagy initiation in response to nutrient depletion.

The significance of PI3K/Akt/mTOR pathway in the control of cell metabolism and negative regulation of autophagy has been discussed extensively in Chapter 1. We therefore asked how IKK activity influenced this signaling network in response to the cell stress starvation. Surprisingly, we found that IKK activity was necessary *in vitro* and *in vivo* for starvation-induced feedback of the PI3K pathway (figure 3.1 and 3.6). These findings are significant because they suggest IKK activity is needed to instruct a cell to turn off metabolic activity and turn on catabolic activity. Cells lacking IKK are unable to initiate an important

program necessary for cells to survive prolonged periods without nourishment which suggests that IKK is a critical integrator of nutrient dependent signal transduction.

We undertook a bioinformatic approach to identify novel substrates of IKK that may direct feedback control of metabolic pathways by comparing the published IKK consensus phosphorylation motif to the amino acid sequence candidate proteins involved in transducing nutrient responsive pathways. The p85 regulatory subunit of PI3K was found to contain a near perfect IKK consensus phosphorylation site in the cSH2 (Ser690) which was further investigated for a role in controlling PI3K activity. We demonstrate that p85 S690 phosphorylation occurs *in vitro* and *in vivo* in an IKK-dependent manner (Figure 3.2 and 3.3). We further showed the cellular starvation induces phosphorylation of Ser690 and that this site is important for feedback inhibition of PI3K in response to cellular starvation (figure 3.3 and 3.5). Importantly, this signaling is not specific to the *in vitro* system with which we have used to investigate this question as we find that mice that are fasted for short periods (6-24hrs) display increased p85 S690 phosphorylation which corresponds with loss of signaling through PI3K/Akt. Importantly, loss of IKK β from livers of mice blocks fasting-induced p85 phosphorylation and feedback inhibition of PI3K/Akt (Figure 3.4).

We next explored the mechanism by which IKK promotes feedback inhibition of PI3K through phosphorylation of the p85 subunit. Examination of the cSH2 crystal structure revealed that Ser690 is found in an important and conserved region of this domain which led to the hypothesis that phosphorylation of Ser690 could disrupt SH2-phospho-tyrosine affinity to promote feedback of PI3K. By analyzing this question *in vitro* and in cells we found that phosphorylation of p85 resulted in a decreased affinity for phospho-tyrosine. This activity

was dependent on IKK activity because cells lacking IKK subunits displayed increased pTYR binding following nutrient deprivation (Figure 3.6). These data point to a model whereby starvation-induced IKK activity serves to feed back to inhibit PI3K/Akt activity by phosphorylating p85 subunit and promoting dissociation from tyrosine phosphorylated (and thus active) signaling complexes (Figure 4.2).

The data presented in chapters 2 and 3 confirm that the IKK complex is a central mediator of metabolic stress in higher eukaryotes. The unbiased screen performed by Criollo et al indicated this to be the case, but the lack of a mechanism in this study left it unclear exactly how this activity was achieved. Aided by informatic tools, we chose to take two approaches to understand how IKK promotes starvation-induced autophagy and, in so doing, identified that starvation rapidly induces IKK to promote feedback of metabolic pathways and following prolonged starvation IKK promotes expression of genes necessary for survival under sustained nutrient deprivation. The autophagy defect observed in IKK deficient cells is highly penetrant which suggests that IKK may be involved in further controlling these pathways in response to cellular starvation. Specific discussion points regarding these questions have been addressed in the specific chapters and will not be covered again. Instead the remainder of this chapter will be used to discuss broader biological implications of the findings presented herein.

4.2 Hypothesis: IKK compensates for loss of mTORC1-PI3K feedback in the absence of amino acids

A major question that continues to arise when discussing IKK-mediated PI3K feedback inhibition is what aspect of starvation induces this event. For the studies above, starvation is achieved by growing cells in Hank's Balanced Salt Solution (HBSS), a media commonly used to monitor induction of autophagy. This media contains low glucose, no serum and no amino acids; HBSS therefore serves a very blunt means of starvation. An important question that must be answered is whether deficiency of a particular nutrient is responsible for IKK activation. Our preliminary data suggests that glucose does not play a role in regulating the activity of IKK and no evidence in the literature exists to dispute this fact (data not shown). Preliminary experiments analyzing IKK activity in response to serum withdrawal have shown that serum starvation of HEK293T cells does induce NF- κ B activity about two-fold above cells grown in basal media as measured by a κ B-luciferase reporter assay (data not shown). However, as indicated below, HBSS containing 10% FBS is still able to induce p85 phosphorylation indicating that other nutrients are likely involved in regulating this pathway. The role of serum withdrawal in activation of IKK and NF- κ B will need to be further explored to determine if the level of activity is significant.

Studies regarding AA withdrawal on the other hand have been a bit more informative. More increasingly we are becoming aware that amino acids are directly sensed by signaling networks as a means of surveying nutritional availability. Cells in culture consume superphysiological concentrations of L-glutamine, more than can be described by the need for nitrogen source (DeBerardinis et al. 2008). L-glutamine serves as a counter pump for

amino acid transporters in the cell as well as a direct metabolite in the TCA cycle important for biomass; both activities coordinate major metabolic programs in the cell (Nicklin et al. 2009; DeBerardinis et al. 2007). Moreover, the significance of branched chain (BC) AA (Leu, Ile, Val) directly regulating mTORC1 to inhibit autophagy was described in Chapter 1. Thus AAs direct much of the metabolism of a cell beyond providing building blocks for protein synthesis or for catabolism as a nitrogen source. The extent of control of signaling by amino acids is not understood, but they could certainly be involved in coordinating cross regulatory signaling. Toward that end a few examples can be found in the literature that demonstrate AA are inhibitors of NF- κ B signaling, consistent with a role for withdrawal activating signaling (Singleton & Wischmeyer 2008; Kuhn et al. 2010).

In order to address whether AA withdrawal was necessary for starvation-induced p85 phosphorylation combinations of AA were added back into HBSS at 10-fold higher levels as compared with normal media. Cells were grown in AA-supplemented media for 20 minutes, harvested for whole cell lysates and prepared for analysis of p85 phosphorylation as described in chapter 3. p85 phosphorylation was observed in cells treated with unsupplemented HBSS or with HBSS supplemented with L-glutamine, a mixture of nonessential (NE) AAs, or 10% serum. Interestingly, HBSS containing 10x Leucine failed to induce p85 phosphorylation and possibly showed levels reduced than those observed from untreated cells (Figure 4.3). This result demonstrates that leucine withdrawal is necessary for IKK-dependent p85 phosphorylation in response to starvation. The ability of leucine withdrawal alone to induce p85 phosphorylation was next addressed. Cells were grown in leucine-deficient DMEM for 1 hour time course and p85 phosphorylation was analyzed as

above. Significant p85 phosphorylation was observed following 1 hour of leucine withdrawal, indicating that while HBSS induces p85 phosphorylation with faster kinetics, leucine withdrawal is sufficient for p85 S690 phosphorylation.

These results, while preliminary, demonstrate that BCAA depletion is an important IKK-inducing stimulus that regulates PI3K feedback inhibition. The adjusted model then suggests a novel mechanism of regulating GF-dependent signaling in the absence of AA; cells have devised a mechanism to restrict PI3K/Akt signaling in the absence of sufficient pools of BCAAs. This finding is in concert with a major theme of this thesis that cells have built in a number of breaks on PI3K activity. These findings become more complicated, yet more intriguing when considering how AA directly regulate mTORC1 and downstream feedback on IRS and PI3K signaling. As described above AA directly activate mTORC1 and inhibit autophagy, withdrawal of AA results in loss of mTORC1 activity and induction of autophagy. Interestingly, prolonged autophagy results in restoration of TOR activity as the AAs released during catabolism ultimately replenish the intracellular concentrations and reactivate signaling (Yu et al. 2010). As previously discussed, activated mTORC1 (in the presence of AA) drives S6K-dependent feedback of PI3K by modulating IRS proteins (Figure 4.4). A prediction from this model is that loss of mTORC1 signaling in response to AA deprivation should lead to reactivation of PI3K, though experimental data suggest that this is not the case, rather only modest reactivation of PI3K/Akt is observed in the absence of AAs. This paradox might suggest that other compensatory feedback loops are in play.

We hypothesized that loss of mTORC1-dependent PI3K feedback was compensated by IKK-dependent p85 phosphorylation and inhibition. To test this hypothesis WT and IKK

DKO mEFs were grown for 2 hours in leucine deficient DMEM and reactivation of PI3K was observed. We predicted that absent an IKK-dependent feedback loop we should observe increased pAKT and downstream signaling (Figure 4.5). Analysis of Akt S473 phosphorylation and the Akt substrate FOXO3a T32 phosphorylation revealed this to be the case. This result reveals a very interesting coordination of PI3K feedback by leucine. mTORC1-mediated GF-dependent PI3K feedback is a relatively new evolutionary adaptation. A more ancient role for mTOR is to be directly modulated by amino acids, this means that in the absence of AA mTOR activity is lost and GF-dependent signaling through PI3K would be hyperactivated. However, it seems that cells have evolved a secondary feedback loop, controlled by the pro-inflammatory kinase IKK, to restrict PI3K/Akt in response to AA deprivation. Interestingly, mTORC1 dependent feedback and IKK-dependent feedback occur at the some of the most upstream steps of PI3K activation. S6K-mediated feedback inhibition occurs through disruption of the interaction between adaptor molecules and activated RTKs (Harrington et al. 2005). IKK-mediated feedback inhibition occurs through disrupting PI3K interaction with phosphorylated tyrosine on these same receptors and adaptors (Figure 3.6 and 4.6).

4.3 Future Directions

A number of interesting questions have emerged from the findings presented herein and should be topic of subsequent studies moving forward. The data presented in Chapter 2 identified an IKK-dependent gene expression program that did not involve the obvious transcription factor NF- κ B. A gaping question remains then, how does IKK achieve

autophagic gene expression in response to starvation? In light of our findings regarding control of PI3K/Akt, a new hypothesis emerges. One consequence of IKK-dependent feedback inhibition of PI3K/Akt is loss of Akt-dependent FOXO inhibition. As discussed above, FOXO transcription factors have recently been identified as regulators of autophagy in higher eukaryotes (Mammucari et al. 2008). FOXO family members should be studied for their ability to activate the autophagic gene expression program we identified in Chapter 2. According to our model, IKK promotes autophagic gene expression in response to starvation, and also promotes feedback inhibition of PI3K/Akt which should result in loss of inhibitory function on downstream FOXO. Loss of IKK blocks both of these activities but its unknown if these activities are dependent on each other, and this relationship should be explored further.

IKK activity is induced in response to most cell stresses to coordinate activation of pro-inflammatory gene expression by NF- κ B transcription factors. In Chapter 2 we identify that the novel IKK/NF- κ B stimulus cellular starvation results in IKK-mediated phosphorylation and feedback inhibition of PI3K. At this point it is unclear if other IKK stimuli, such as TNF α for example, also induce feedback inhibition of PI3K through p85 Ser690 phosphorylation. TNF α induces Akt S473 phosphorylation and loss of Akt blocks TNF α -stimulated NF- κ B (Ozes et al. 1999). Given this finding we would hypothesize that TNF α -induced IKK phosphorylates p85 to dampen the upstream Akt input prevent hyper-activation of NF- κ B. In this scenario IKK would play the role of its own feedback inhibitor, which is more consistent with previous identification of IKK-dependent roles in controlling NF- κ B (Häcker & Karin 2006).

A major complication encountered throughout the work characterizing p85 S690 phosphorylation was the fact that the p85 α nSH2 domain contains a site analogous to S690 (S400). Evidence from our *in vitro* experiments indicates that IKK also phosphorylates S400, but the role of this modification is not well known. The nSH2 domain has distinct properties from the cSH2 domain which are likely the result of direct contacts with the p110 catalytic subunit and nSH2 domain. We find that S400A mutation alters p85 solubility compared to WT or S690A mutations. It will be interesting to explore the importance of S400 phosphorylation in controlling PI3K. An intriguing idea is that S400 phosphorylation could effect the autoinhibitory function of p85 nSH2 domain; while no evidence exists for this to be the case, effects like this may describe some of our confusing biochemical results. Complicating matters is that all five p85 family members contain analogous sites. We tried to focus on the role of p85 α given it is the primary regulator molecule of ClassIA PI3K, but a broader approach should be taken to fully appreciate the extent that this modification has on overall PI3K activity.

Having observed that all p85 SH2 domains contain consensus IKK phosphorylation motifs in conserved regions and noticing that previous structural analysis has found analogous sites in some but not all SH2 containing proteins a bioinformatic analysis was undertaken to determine the extent of IKK phosphorylation sites in SH2 domain containing proteins (Hoedemaeker et al. 1999). Surprisingly, 15-20% of all SH2 domains were found to contain conserved consensus phosphorylation motifs (Hsia H-C, personal communication). This finding suggests that IKK may play an even broader role in regulating phospho-tyrosine

binding cell wide in response to stress. These other putative substrates are currently under investigation.

An interesting theme that emerges is the relative proximity of the IKK and mTOR complex. These two complexes seem to respond to starvation and amino acid deprivation with the same kinetics and modulate effectors within the same cellular compartments. More interestingly, treating cells with rapamycin (simple mTOR inhibition) nearly mimics acute starvation and is often used alongside nutrient deprivation in autophagy studies as a secondary control (Peng et al. 2002). Indeed, Criollo used rapamycin alongside a number of autophagy inducers in their analysis of IKK-dependent autophagy. Interestingly, inhibition of mTORC1 with rapamycin resulted in increases in IKK kinase activity and downstream signaling. Moreover, rapamycin-induced autophagy required IKK activity because blocking IKK severely impaired the autophagic response to rapamycin. Our data analyzing leucine withdrawal reveals a similar relationship between mTOR inhibition, IKK activation, and kinetics of PI3K feedback inhibition. Our work has not established a functional link as Criollo did but future studies should determine if one exists. Interestingly, work from our own lab has established that mTOR and IKK form a high molecular weight complex downstream of constitutively active Akt (Dan et al. 2008). The significance of IKK/mTOR physical interaction has not been explored either in basally growing WT cells or in response to cellular starvation, and these questions should be of top priority.

If I've learned anything in graduate school (for better or worse) it's that the last information to supply the reader with is how the findings reported will cure disease. Given the obvious importance of both IKK/NF- κ B signaling and PI3K/Akt/mTOR in cancer and

other disorders it seems likely that misregulation of IKK-dependent metabolism could potentially be involved in disease progression. Interestingly, the data presented herein suggest that in response to physiological stress IKK is important for restricting the activity of PI3K. Other work from our lab has demonstrated that IKK drives mTOR activity in PTEN null cancer suggesting that IKK can both positively and negatively regulate this pathway dependent on cellular context. These findings suggest that cancer cells hijack survival pathways to promote tumorigenesis (Figure 4.7). Prior to initiating the studies presented herein we attempted to address how IKK regulated autophagy in cancer cells and found this to be far too complicated of a system. We then analyzed the physiological response to induction of autophagy and uncovered interesting mechanisms of gene expression and feedback signaling. These findings must now be reapplied to studies in cancer cells in order to determine if either of these programs has become misregulated to promote the malignant state.

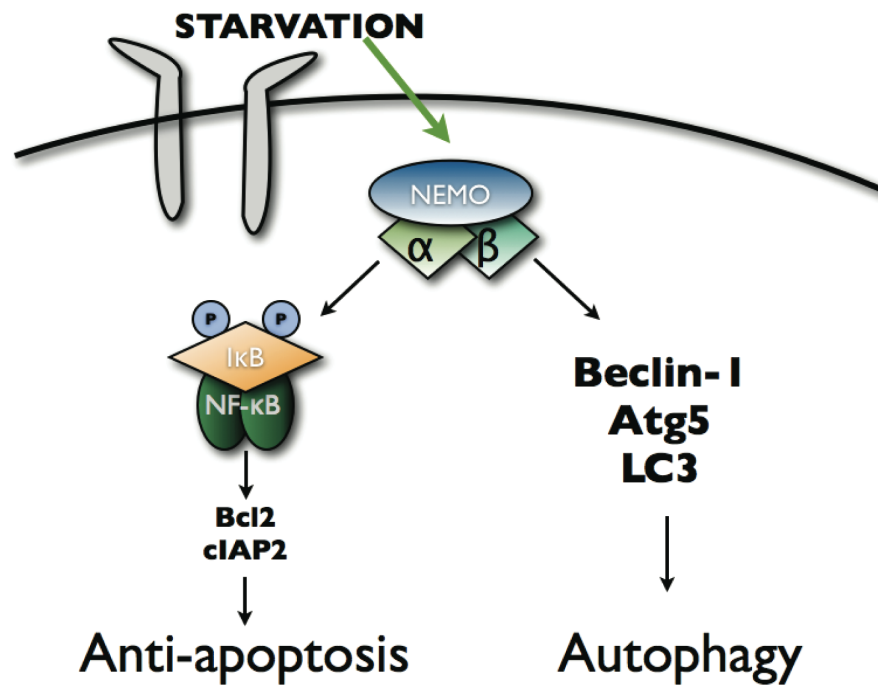

Figure 4.1 Starvation-induced IKK control of gene expression

We show in chapter 1 that cellular starvation induces IKK/NF- κ B activity resulting in increased expression of anti-apoptotic genes such as Bcl2, cIAP2 and others. We also demonstrate that IKK controls mRNA expression for the genes encoding Beclin-1, Atg5, and LC3. This IKK-dependent activity is independent of the ability to regulate NF- κ B.

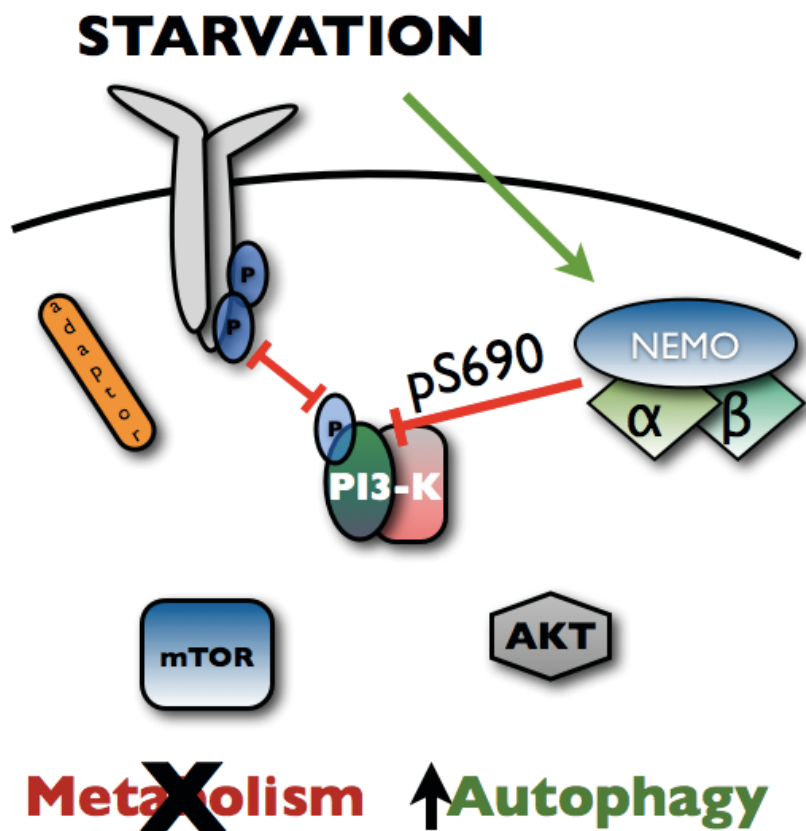

Figure 4.2 Starvation-induced IKK activity controls PI3K feedback inhibition through p85 subunit phosphorylation.

We show in chapter 2 IKK is important for feedback inhibition of PI3K/Akt in response to cellular starvation. We identify that the p85 regulatory subunit of PI3K is a novel substrate of IKK that is phosphorylated at Serine690 in response to cellular starvation. Phosphorylation of Serine690 in c-terminal SH2 domain is important for the feedback inhibition of PI3K/Akt in response to starvation. Finally, we identify that IKK controls PI3K activity by modulating p85-SH2 domain affinity for phospho-tyrosine.

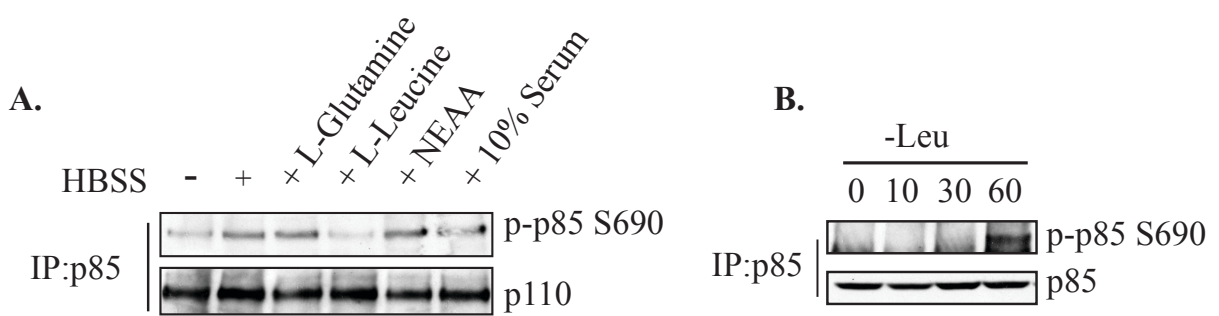

Figure 4.3 Leucine withdrawal is necessary and sufficient for starvation-induced p85 α Ser690 phosphorylation.

A. WT mEFs were treated with HBSS supplemented with various nutrients for 20 minutes and p85 phosphorylation was described as previously described. Co-precipitated p110 was blotted for a control to show equivalent PI3K precipitated.

B. WT mEFs were treated with Leucine deficient DMEM for an hour timecourse and p85 phosphorylation was measured.

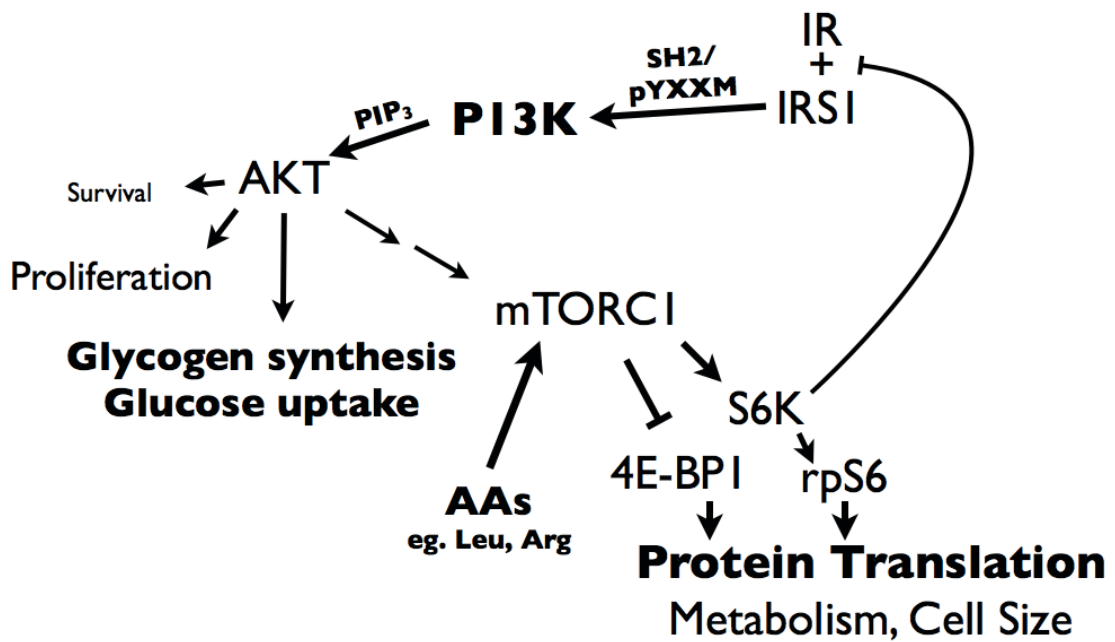

Figure 4.4 mTORC1-S6K dependent feedback inhibition of PI3K/Akt

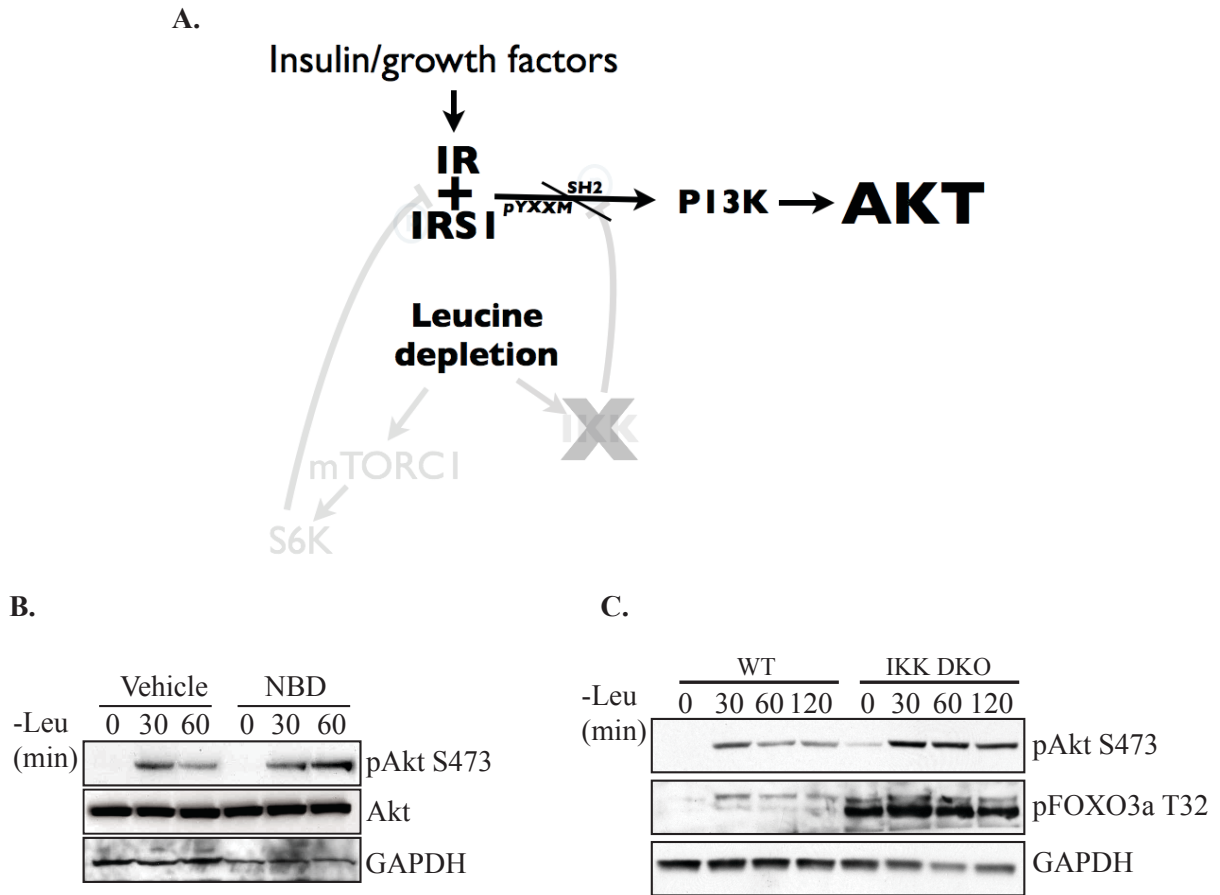

Figure 4.5 Compensatory IKK-dependent feedback inhibition of PI3K in the absence of Leucine - Implications for loss of mTORC1 feedback

A. We hypothesized that IKK controls a secondary feedback loop to restrict PI3K in the absence of leucine and mTOR mediated feedback. A prediction then is that loss of a secondary IKK-dependent PI3K feedback should result in hyper-reactivation of PI3K activity following leucine withdrawal and loss of mTORC1 feedback.

B. WT mEFs were treated with Leu depleted media in the presence or absence of the NBD peptide and IKK-dependent effects on reactivation of AKT were monitored.

C. WT and IKK DKO mEFs were treated for two hours with leu depleted media and IKK-dependent effects on PI3K activity were monitored.

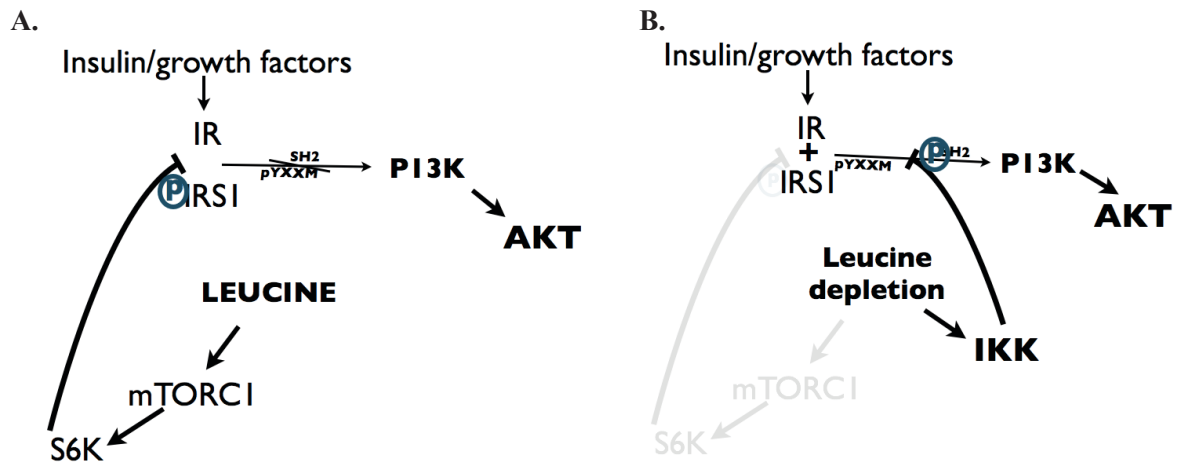

Figure 4.6 Feedback inhibition of GF-dependent PI3K activity in the presence and absence of Leucine

A. In the presence of leucine mTORC1 directed S6K activity phosphorylates IRS proteins to feedback inhibit GF-dependent activation of PI3K/Akt.

B. In the absence of leucine mTORC1 dependent feedback inhibition of growth factor responsive signaling pathways is lost. Concurrent activation of a secondary feedback loop involving IKK-dependent phosphorylation of PI3K compensates to restrict GF-dependent signaling in the absence of amino acids.

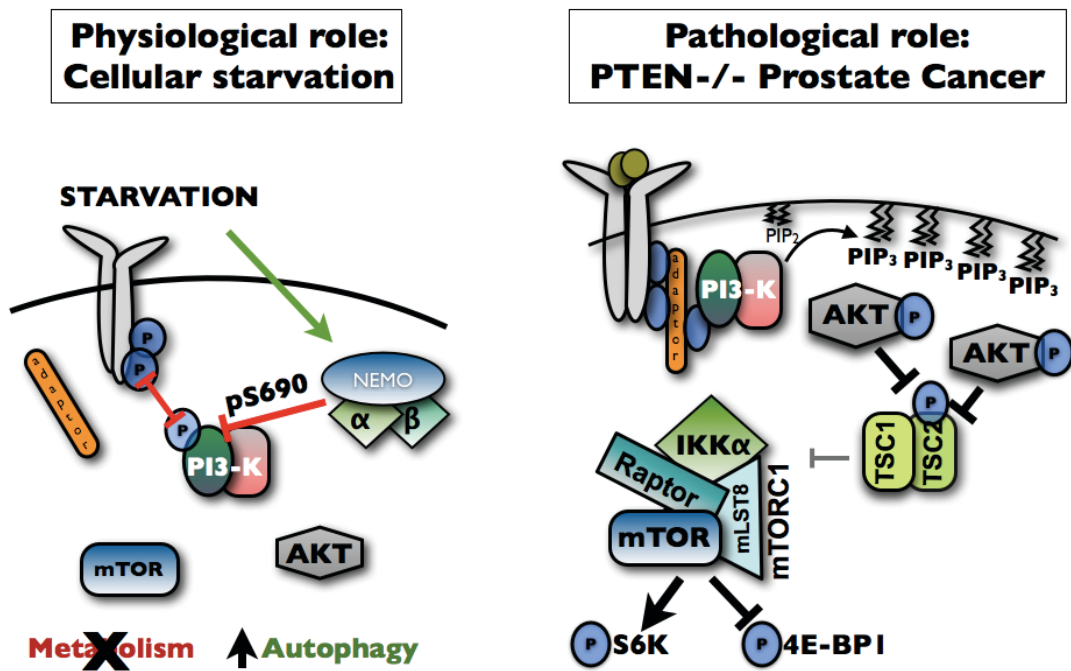

Figure 4.7 Model for IKK control of PI3K/Akt/mTOR in physiology and pathology
 A. In response to physiological stress IKK activity is induced to restrict PI3K/Akt/mTOR signaling in the absence of sufficient nutrient availability.
 B. In PTEN^{-/-} cancer (constitutive activation of Akt) IKK α associates with and controls mTORC1 activity.

REFERENCES

- Comb, W.C. et al., 2010. IKK-dependent, NF- κ B-independent control of autophagic gene expression. *Oncogene*, 30(14), pp.1727-1732.
- Dan, H.C. et al., 2008. Akt-dependent regulation of NF- κ B is controlled by mTOR and Raptor in association with IKK. *Genes & Development*, 22(11), pp.1490-1500.
- DeBerardinis, R.J. et al., 2007. Beyond aerobic glycolysis: transformed cells can engage in glutamine metabolism that exceeds the requirement for protein and nucleotide synthesis. *Proceedings of the National Academy of Sciences of the United States of America*, 104 (49), pp.19345-19350.
- DeBerardinis, R.J. et al., 2008. The biology of cancer: metabolic reprogramming fuels cell growth and proliferation. *Cell metabolism*, 7(1), pp.11-20.
- Harrington, L.S., Findlay, G.M. & Lamb, R.F., 2005. Restraining PI3K: mTOR signalling goes back to the membrane. *Trends in biochemical sciences*, 30(1), pp.35-42.
- Häcker, H. & Karin, M., 2006. Regulation and function of IKK and IKK-related kinases. *Science's STKE : signal transduction knowledge environment*, 2006(357), p.re13.
- Hoedemaeker, F.J. et al., 1999. Crystal structure of the C-terminal SH2 domain of the p85 α regulatory subunit of phosphoinositide 3-kinase: an SH2 domain mimicking its own substrate. *Journal of Molecular Biology*, 292(4), pp.763-770.
- Kuhn, K.S. et al., 2010. Glutamine as indispensable nutrient in oncology: experimental and clinical evidence. *European journal of nutrition*, 49(4), pp.197-210.
- Mammucari, C., Schiaffino, S. & Sandri, M., 2008. Downstream of Akt: FoxO3 and mTOR in the regulation of autophagy in skeletal muscle. *Autophagy*, 4(4), pp.524-526.
- Nicklin, P. et al., 2009. Bidirectional Transport of Amino Acids Regulates mTOR and Autophagy. *Cell*, 136(3), pp.521-534.
- Ozes, O.N. et al., 1999. NF- κ B activation by tumour necrosis factor requires the Akt serine-threonine kinase. *Nature*, 401(6748), pp.82-85.
- Peng, T., Golub, T.R. & Sabatini, D.M., 2002. The immunosuppressant rapamycin mimics a starvation-like signal distinct from amino acid and glucose deprivation. *Molecular and Cellular Biology*, 22(15), pp.5575-5584.

Singleton, K.D. & Wischmeyer, P.E., 2008. Glutamine attenuates inflammation and NF-kappaB activation via Cullin-1 deneddylation. *Biochemical and Biophysical Research Communications*, 373(3), pp.445-449.

Yu, L. et al., 2010. Termination of autophagy and reformation of lysosomes regulated by mTOR. *Nature*, 465(7300), pp.942-946.