

REVIEW ARTICLE

Cancer stem cells (CSCs) in cancer progression and therapy

Masoud Najafi¹ | Bagher Farhood² | Keywan Mortezaee³ 

¹Radiology and Nuclear Medicine Department, School of Paramedical Sciences, Kermanshah University of Medical Sciences, Kermanshah, Iran

²Departments of Medical Physics and Radiology, Faculty of Paramedical Sciences, Kashan University of Medical Sciences, Kashan, Iran

³Department of Anatomy, School of Medicine, Kurdistan University of Medical Sciences, Sanandaj, Iran

Correspondence

Keywan Mortezaee, Department of Anatomy, School of Medicine, Kurdistan University of Medical Sciences, Sanandaj 66177-13446, Iran.

Email: keywan987@yahoo.com; mortezaee.k@muk.ac.ir

Abstract

Cancer stem cells (CSCs) are self-renewable cell types that are identified in most types of liquid and solid cancers and contributed to tumor onset, expansion, resistance, recurrence, and metastasis after therapy. CSCs are identified from the expression of cell surface markers, which is tumor-type dependent. The transition between CSCs with cancer cells and other non-CSCs occurs in cancers, which is possibly under the control of signals from CSCs and tumor microenvironment (TME), including CSC niche. Cancer-associated fibroblasts are among the most influential cells for promoting both differentiation of CSCs and dedifferentiation of non-CSCs toward attaining a CSC-like phenotype. WNT/ β -catenin, transforming growth factor- β , Hedgehog, and Notch are important signals for maintaining self-renewal in CSCs. An effective therapeutic strategy relies on targeting both CSCs and non-CSCs to remove a possible chance of tumor relapse. There are multiple ways to target CSCs, including immunotherapy, hormone therapy, (mi)siRNA delivery, and gene knockout. Such approaches can be designed for suppressing CSC stemness, tumorigenic cues from TME, CSC extrinsic and/or intrinsic signaling, hypoxia or for promoting differentiation in the cells. Because of sharing a range of characteristics to normal stem/progenitor cells, CSCs must be targeted based on their unique markers and their preferential expression of antigens.

KEYWORDS

cancer-associated fibroblast (CAF), cancer cell, cancer stem cell (CSC), CD133, CD44, CSC niche, dedifferentiation, epithelial–mesenchymal transition (EMT), hypoxia, Notch, therapy resistance, transforming growth factor- β (TGF- β), tumor microenvironment (TME), WNT, β -catenin

1 | INTRODUCTION

Tumors (solid and liquid) are composed of a large number of bulk cancer cells along with a small population of cancer stem cells (CSCs) (Marquardt, Solanki, Spitschak, Vera, & Pützer, 2018; Takebe, Harris, Warren, & Ivy, 2011). CSCs are a group of quiescent self-renewing cell types pre-exist in primary cancers and localized within the tumor niches bearing enriched functional potential to drive cancer growth, to reconstruct their heterogeneity (Batlle & Clevers, 2017; Lytle, Barber, & Reya, 2018) and so to make variations in cancer regenerative capacity (Visvader & Lindeman, 2008). The cells have the capacity to generate *in vitro* clones and to reform cancers after their transplantation into immunodeficient animals (Golan et al., 2018). CSCs were first defined as a subpopulation of cancer cells that

can expand the pool of CSCs and differentiate into progenitor cancer cells via symmetric and asymmetric divisions (Baumann, Krause, & Hill, 2008). Since their first identification in human acute myeloid leukemia (AML), CSCs have been harvested from most of the solid tumors and malignancies of hematopoietic origin (Dean, Fojo, & Bates, 2005; D. Zhang, Tang, & Rycaj, 2018), and their tumorigenic activity is attested in several cancers, including brain, liver, lung, colon, breast, ovarian, pancreas, prostate, melanoma, head and neck, and bladder (Takebe et al., 2011). The frequency of CSCs increases upon tumor progression (D. Zhang et al., 2018) and is seemingly different from one cancer to another (Visvader & Lindeman, 2008). The concept of CSC derives from the fact that tumors are considered as dysregulated tissue clones that their constant propagation is vested in a distinct subset of cell types called CSCs (Nguyen, Vanner,

Dirks, & Eaves, 2012). The term “cancer stem cell” is reflective of the stem-like features and the potential of the cells to sustain tumorigenesis constantly (Visvader & Lindeman, 2008). Other terms used for these cells (in addition to CSCs) from research studies are “tumor rescuing units,” “tumor-progenitor cells,” “functional tumor stem cells,” “cancer-stem-like cells,” “tumor-propagating cells” and “tumor- or cancer-initiating cells” (Baumann et al., 2008; Dianat-Moghadam et al., 2018). The term cancer-initiating cells is used because of the ability of the cells to generate a progressively growing cancer that consists of cells resembling those in the original tumor (Nguyen et al., 2012).

There are three implicit origins for CSCs: (a) (epi)genetic changes like methylation, demethylation, mutations, and rearrangement in the stem/progenitor cell pool (niche) or even in differentiated cells; (b) spontaneous oncogenic reprogramming in somatic cells; and (c) tumor microenvironment (TME) activation through providing extracellular cues (Dianat-Moghadam et al., 2018). CSCs usually share many of their defining features with normal stem cells, including relative quiescence, active DNA repair systems, aggressive proliferation, and drug resistance (Batlle & Clevers, 2017; Dean et al., 2005; Lytle et al., 2018). Their multipotent characteristic has also been identified for cancers, such as glioblastoma (Gilbertson & Rich, 2007). These features are considered as a possible reason for higher incidence of cancer development in tissues enriched in stem cells (Jaeckel et al., 2018) in which mutation in the stem-like cells is more potent for generating cancers than mutations in other more differentiated cell types, reported in colon cancer (Jaeckel et al., 2018). Subventricular zone in the brain, for instance, exhibits a high degree of cell proliferation, and it seems that this region is one of the anatomical origins for brain CSCs (Vescovi, Galli, & Reynolds, 2006). Functional properties of the stem cells during cancer expansion and responses to the therapeutic approaches is defined by TME (Lenos et al., 2018) that plays important roles in development and progression of tumor (Goto et al., 2018).

The cellular transition between CSCs with cancer cells and other non-CSCs has received too much attention recently (Z. Liu et al., 2018). Mutations in normal stem cells is responsible for dysregulation of their self-renewal and further transformation of the cells into CSCs (Pardal, Clarke, & Morrison, 2003). These mutated CSCs have increased proliferation, reduced apoptosis, and enhanced immune evasion capacity resulting in expansion of the stem cell compartment, which is a typical feature of malignant tumors (Dean et al., 2005). The ongoing mutagenesis is responsible for the generation of diverse phenotypes of cancer cells from CSCs (Pardal et al., 2003).

CSCs have the ability to xenograft cancer and differentiate into a number of heterogeneous population of cells, which is for maintaining and propagating cancers (Medema & Vermeulen, 2011; Nakano et al., 2018). CSCs have extensive proliferative potential to regenerate a tumor and form disseminated metastatic tumors, whereas the cancer cells derived from them have limited proliferative and regenerative capacity, thereby forming limited benign tumors (Dean et al., 2005; Pardal et al., 2003). The diverse proliferative capacity between the two cell types was the basis for proving the existence of CSCs at first in the context of AML (Pardal et al., 2003).

CSC targeting for cancer therapy is considered as an interesting area of current research, and killing of the cells is thought to be an essential component of efficient antitumor therapies (Medema, 2017). CSCs are needed to be removed in order for cancer-targeted therapy to be curative. In fact, even a single CSC can theoretically capable of reconstituting an entire tumor (Hermann & Sainz, 2018). There are still too much complexities regarding the actual identity of the cells, their precise location within a tumor and established ways of targeting them. Improving the understanding about the characteristics of CSCs and signaling mediated by them would help to develop more compatible therapeutic approaches for targeting these cells. To write this review, we intended to focus on CSCs and their implication in the initiation and progression of tumor. CSCs are highly plastic cells with diverse origins and are known as the leader cells contributed to the failure of chemo/radiotherapy. The review provides knowledge about CSC plasticity, identification, functioning, cross-talking, and related signaling. Then, we will place the knowledge harvested from the review in the context of therapeutic approaches. The primary aim of the therapeutic approaches is to sensitize CSCs to respond to such strategies. Then, these protocols are needed to be completed by targeting secondary intriguing factors responsible for the enrichment of the CSCs within their niche. PubMed database was searched to find relevant articles. The criteria for article selection was based on the quality of journals, the novelty of subjects and the number of citations per year for relevant articles. More than 500 papers were scanned for this review by searching the keywords “cancer stem cells” and “cancer,” among them approximately 100 papers have pursued the criteria for further interpretation.

2 | PLASTICITY OF CSCs (STEMNESS, DIFFERENTIATION, AND DEDIFFERENTIATION)

CSCs share features similar to tissue-resident stem cells, including self-renewal, quiescence, and differentiation (D. Zhang et al., 2018). Like tissue-resident cells, CSCs follow two ways of divisions: symmetric and asymmetric. In the symmetric division, every stem cells divide invariably to create one daughter cell and one new stem cell, whereas in the asymmetric division, the cells depending on the space available in the niche can possibly create a diverse number of new cells, may be zero, one, or two in number. Normally, there is a balance between symmetric and asymmetric divisions, which is for restricting cancer progression or for diverting tumors from high to low grade. Upon tumorigenesis, however, there is a shift toward enhanced symmetric division (renewal), leading to the expansion of CSC fraction that subsequently drives a more vigorous and undifferentiated state in cancers (progression from low to high-grade cancer). Therefore, an increase in the asymmetric division can be served as an approach to halt the aggressive progression of cancer (Batlle & Clevers, 2017; Lytle et al., 2018). The nearby committed cells within the niche send signals to the stem cells to keep their

stemness and to restrict their differentiation. The point here is that both CSCs and the nearby non-CSCs are plastic, and depending on the environmental cues they receive, the two types of cells could attain self-renewal capacity and are able to be tumorigenic even equally (Batlle & Clevers, 2017). The plasticity of CSCs is also dependent on tumor type and cell context (Gao et al., 2018). The importance of this point is for therapeutic designing strategies in which a prolonged success will be expected only when both non-CSCs and CSCs are targeted, not just CSCs.

In the context of cancer, there is a large and exclusive association between plasticity mostly with CSCs, while in non-CSCs this plastic feature is considerably restricted. However, under some circumstances, non-CSCs can replenish the CSC population (Hermann & Sainz, 2018). CSCs have the capacity to differentiate into non-CSCs (Nakano et al., 2018). Dedifferentiation is a process by which non-CSCs even in a complete differentiated state can retain their tumor-initiating capacity by replacing the either lost CSCs or cancer cells (Batlle & Clevers, 2017; Chaffer et al., 2011). For example, CSC-like properties of breast cancer cells is reported to be potentiated after exposure of the cells to the adipsin derived from mammary-adipose-derived stem cells (Goto et al., 2018). Stemness-related genes can also be activated in cancer cells to exhibit CSC-like properties. Oct4, sex determining region γ -box 2 (Sox2), Nanog, CD44 (also called PGP1), CD133 (also called PROM1), and ABCG2 are examples of these genes (Cao et al., 2018; Dianat-Moghadam et al., 2018). For example, upregulation of Sox2 in lung cancer cells could enhance expression of pluripotent factors OCT4 and Nanog in the cells and drives them toward a CSC-like phenotype (Ooki et al., 2018). Interleukin 6 (IL-6) released from CSCs is responsible for keeping a dynamic equilibrium between the cells with non-CSCs, shown in breast and prostate cancer (Iliopoulos, Hirsch, Wang, & Struhl, 2011).

Epithelial-mesenchymal transition (EMT) has been identified as one of the important mechanisms controlling CSC biology (D. Zhang et al., 2018). The importance of this is in a report that cells with increased rates of EMT plasticity and mobility are known as CSCs (Marquardt et al., 2018). EMT is also a mechanism for the acquisition of a CSC-like phenotype in non-CSCs (C. Chen et al., 2018). During the EMT, epithelial cells would lose their polarity and cell-to-cell contact to acquire motility and invasiveness (Ji et al., 2018). TWIST1 and SNAI1 (Snail) are master regulators of EMT and the key genes for inducing dedifferentiation of non-CSCs toward a CSC-like state (Batlle & Clevers, 2017; Nakano et al., 2018). TWIST1 mediates this process in a mechanism dependent or independent on EMT (Nakano et al., 2018). ZEB1 is another key regulator of the EMT that its activation by transforming growth factor- β (TGF- β) in non-CSCs could switch them to the CSC state (Chaffer et al., 2013). TGF- β inducible effects on EMT is also carried out by reduction of the rate for ferritin heavy chain (FTH-1) that is known as a negative regulator of CSC expansion and EMT. Iron trafficking in CSCs has shown to be more robust than other cells within a tumor, which is for the promotion of CSC enrichment (El Hout, Dos Santos, Hamai, & Mehrpour, 2018). CSCs like other stem cells have mesenchymal-like phenotype (Batlle & Clevers, 2017). This phenotype can be reactivated in cancer cells through expression of

specific transmembrane proteins (ex, glycoprotein nmb) on the surface of the cells (C. Chen et al., 2018) or induction of the EMT-related transcription factors. This reactivation can facilitate migratory and invasiveness features of the CSC-like cells. These migratory cells when reached to the target metastatic organ probably reprogram again toward their primary cells by silencing EMT mediators. This EMT programming is apparently different in CSCs compared with stem cells within the normal tissue (Batlle & Clevers, 2017). In Figure 1, the plasticity of CSCs for differentiation and the capacity of non-CSCs like cancer cells for dedifferentiation toward attaining a CSC-like phenotype has been clarified.

3 | IDENTIFICATION OF CSCs

CSCs are highly plastic and hidden in tumors that hinder their easy identification and eradication. Their identification is generally based on cell surface marker expression (Dianat-Moghadam et al., 2018). Evaluation of the rate of expressions for related genes and protein signature in CSCs is reflective of their density in patient's tumor tissues (Marquardt et al., 2018). CD24, CD26, CD44, CD133, CD166, aldehyde dehydrogenase (ALDH) and Ep-CAM (also called CD326 or epithelial-specific antigen/ESA) are examples of CSC-specific surface markers (Dianat-Moghadam et al., 2018). CD24, CD34, CD44, CD166, CD133, and ALDH1 are used to identify CSCs in solid tumors (da Silva-Diz, Lorenzo-Sanz, Bernat-Peguera, Lopez-Cerda, & Muñoz, 2018). One of the key functions of the CSC surface markers is to mediate adhesion of the cells to their niche. Examples of such markers are CD29 (β 1-integrin), CD44, CD133, CD166, and EpCAM (De Robertis, Poeta, Signori, & Fazio, 2018). ALDH1 is a NAD(P)-dependent enzyme responsible for the oxidation of aldehydes in an intracellular milieu into carboxylic acids, and it is related to the tumorigenic and metastatic features in CSCs (Bai, Ni, Beretov, Graham, & Li, 2018).

Expression of the surface markers in the CSCs is different from other cells within the tumor tissue (Batlle & Clevers, 2017). The stem/progenitor cells are often the origins for cancer cells and would pass on their phenotypical traits to the cancer cell population, especially to the CSCs (Comoglio, Trusolino, & Boccaccio, 2018). Thus, expression of stem cell specific markers in an unrelated organ can be exploited for identifying the cells (Batlle & Clevers, 2017). For example, B-lymphoma moloney murine leukemia virus insertion region-1 (BMI1) is required for self-renewal of both CSCs and normal stem/progenitor cells (Goto et al., 2018). CD133⁺ CSCs are found in cancers like glioblastoma, ependymoma, lung, and colorectal cancer (CRC; Baumann et al., 2008; Cao et al., 2018; Gilbertson & Rich, 2007), CD44⁺ CSCs are found in cancers like breast cancer (Gilbertson & Rich, 2007). In the brain, CD133 is used as both a marker for identifying normal neural precursors in human and for the enrichment of CSCs (Vescovi et al., 2006). Oligodendrocyte lineage transcription factor 2 (OLIG2) promotes proliferation of both CSCs and neural progenitor cells in glioblastoma (Gilbertson & Rich, 2007). A point is that although CSCs exhibit markers of normal stem cells on their surface, the process of glycosylation of these cell surface

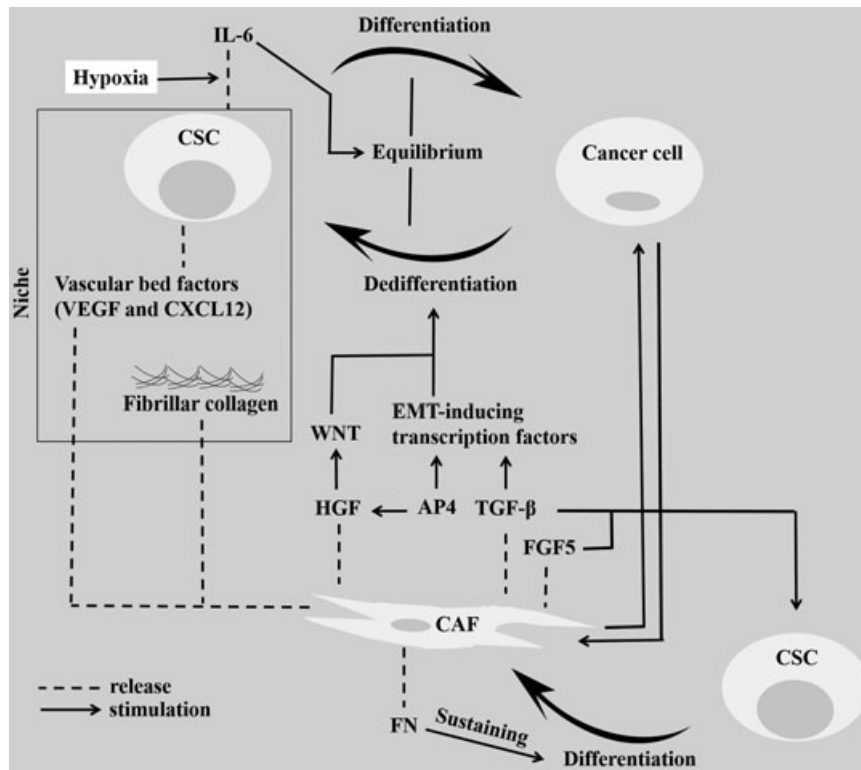

FIGURE 1 Cancer stem cell (CSC) plasticity. CSCs can be differentiated into cancer cells. Cancer cells, in turn, receive signals from tumor microenvironment (TME) to dedifferentiate into CSCs. Cancer-associated fibroblasts (CAFs) are the key cells in directing CSC plasticity through promoting cancer cell dedifferentiation and providing a supportive niche (constructed from fibrillary collagens) for their colonization and chemoresistance features. This niche also contains vascular bed constructed by a cooperation work between CSCs and CAFs. Hepatocyte growth factor (HGF) derived from CAFs stimulates WNT signaling in cancer cells for further promotion of their dedifferentiation. CSCs release interleukin (IL)-6 to keep a dynamic equilibrium between differentiation and dedifferentiation of the cells. The release of transforming growth factor- β (TGF- β) and fibroblast growth factor 5 (FGF5) from CAFs induces myofibroblast reprogramming in the CSCs for metastatic purposes. From these myofibroblastic cells, fibronectin (FN) is released to sustain the reprogramming process. CXCL12: CXC motif ligand 12; EMT: epithelial-mesenchymal transition; VEGF: vascular endothelial growth factor

markers is different in CSCs compared with that in normal stem cells (De Robertis et al., 2018). Some markers are inherited in CSCs in association with their tumorigenic potential. These are called “oncogene inherited” markers. Tumors with active mutations of RAS pathway often harbor the oncogenic drivers. An example of such markers is MET, so the wide-spread expression of such markers in tumors can be interpreted as the expansion of CSCs with stem and/or progenitor features (Comoglio et al., 2018). Markers identified for CSCs has been described in Figure 2, and cancer-dependent expression of markers in CSCs has been shown in Table 1. The point here is that some markers are specific for the cells and others are not. This diversity is dependent on the type of tumor, so the expression of one marker in a type of tumor may exceed the others. An example of such markers is leucine-rich repeat-containing G protein-coupled receptor 5 (Lgr5). Lgr5 is an intestinal stem cell marker that is expressed in CSCs harvested from patients with colon cancer and animal models (Lenos et al., 2018; Medema, 2017), and its expression is associated with the clonogenic features (Lenos et al., 2018) and production of progeny that undergo progressive differentiation but with slower kinetics compared with their nontransformed counterparts. This marker, however, is not so detrimental for

CSC identification, as it has been reported that only a small number of adenoma cells that stained positive for this marker act as CSCs (Batlle & Clevers, 2017). Flow cytometry-dependent functional

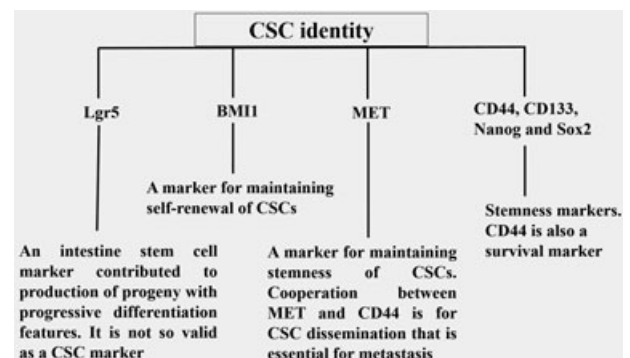

FIGURE 2 Cancer stem cell (CSC) identity. CSCs can be recognized through the expression of markers on their surface. Expression of the markers can be specific for one type of cancer but not for others. Leucine-rich repeat-containing G protein-coupled receptor 5 (Lgr5) is an example of these markers that is specific for intestinal cancers. BMI1: B-lymphoma moloney murine leukemia virus insertion region-1; Sox2: sex determining region y-box 2

TABLE 1 Cancer stem cell (CSC) markers in various cancers

Type of cancer	Markers	References
Breast	CD44 and CD133	Bai et al. (2018)
CRC	CD24, CD29, CD44, CD51, CD133, CD166, Lrg5, Sox2, EpCAM, and BMI1	De Robertis et al. (2018); Medema and Vermeulen (2011); Sui et al. (2018); Visvader and Lindeman (2008); Wang, Fu, Sun, Guo, & DuBois (2015)
Glioblastoma	CD133, nestin, and A2B5	Gilbertson and Rich (2007); Haspels et al. (2018)
Lung	CD44, CD133, CD166, and EpCAM	Cao et al. (2018); Visvader and Lindeman (2008); Zakaria, Mohd Yusoff, Zakaria, Widera, & Yahaya (2018)
Ovary	CD44 and CD133	C. Liu et al. (2011); Xiang et al. (2015)
Pancreas	CD44 and CD133	C. Liu et al. (2011); Visvader and Lindeman (2008)
Prostate	CD44, CD51, and CD133	Sui et al. (2018); Visvader and Lindeman (2008)
Ependymoma	CD133 and nestin	Gilbertson and Rich (2007)
AML	CD34	Nguyen et al. (2012)
Skin	CD34	Malanchi et al. (2008)
HCC	CD44, CD90, CD133, and EpCAM	Gao et al. (2018); Visvader and Lindeman (2008); Yoshida (2018)
Bladder	CD44	C. Liu et al. (2011)
Gastric	CD44	Ji et al. (2018)

Note. AML: acute myeloid leukemia; CRC: colorectal cancer; HCC: hepatocellular carcinoma; Sox2: sex determining region y-box 2.

assays can be applied as an alternative approach for the identification of CSCs (Takebe et al., 2011). For example, flow cytometry tracing of the enzymatic activity for ALDH1 can be used as a specific marker for identification and isolation of colon CSCs, as this marker directs their maintenance and propagation (Dianat-Moghadam et al., 2018; E.H. Huang et al., 2009).

4 | CSC-RELATED SIGNALING

CSCs utilize many of the same signaling pathways found in normal stem cells that are called developmental signaling, including WNT, Notch, and Hedgehog (Hh; Marquardt et al., 2018; Takebe et al., 2011). TGF- β along with phosphoinositide 3 kinase (PI3K)/AKT, STAT or EGFR are oncogenic cascades in CSCs (Marquardt et al., 2018). In Figure 3, a concise overlook toward signaling related to CSC tumorigenic features has been shown. Below a number of the key signaling pathways are presented.

4.1 | Transforming growth factor- β

TGF- β is a differentiation signal, and the general concept may possibly be that this growth factor is downregulated in stem cells within their niche (Batlle & Clevers, 2017). TGF- β through activation of EMT-inducing transcription factors could promote conversion of cancer cells toward a CSC-like state. This activation occurs through TGF- β inducible effects on other signaling including ERK and PI3K/AKT (Mortezaee, 2018; Najafi, Salehi et al., 2018; Nakano et al., 2018). TGF- β is also important for sustained expression of master stem cell state regulators, namely blocker of DNA binding (ID) regulators (Comoglio et al., 2018). ID regulators are transcriptional regulators that are frequently regulated in most of the human cancers. Accumulation of ID4 is contributed to stemness phenotype in breast cancer, and knockdown of ID1, ID2, and ID4 in mice glioma is associated with impaired CSC properties (Lasorella, Benezra, & Iavarone, 2014).

FIGURE 3 Cancer stem cell (CSC) related signaling. Transforming growth factor- β (TGF- β), Hedgehog (Hh), Notch, and WNT/ β -catenin are dominant signaling in promoting stemness of CSCs. EGF: epidermal growth factor; FGFR: fibroblast growth factor receptor; MEK, mitogen-activated protein kinase kinase

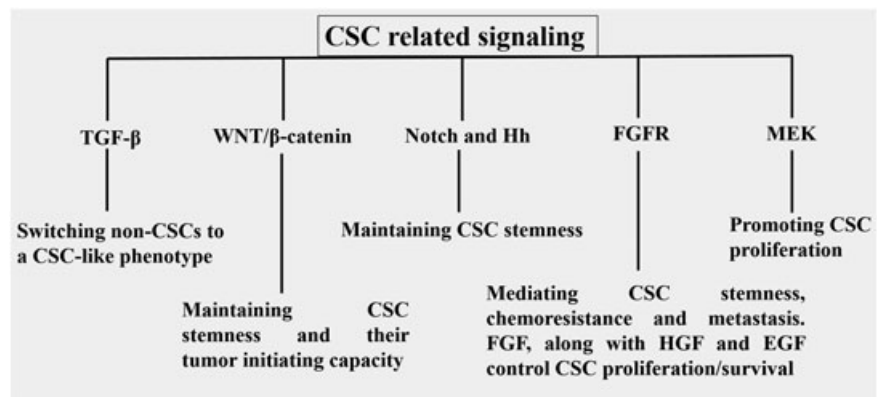

4.2 | WNT/ β -catenin

WNT signaling is for keeping self-renewal in both CSCs and non-CSCs maintaining them in an undifferentiated state, so activation of WNT signaling is associated with the initiation of cancer (Batlle & Clevers, 2017). WNT/ β -catenin along with Notch pathway is activated by activating protein-4 (AP4) for increasing the number of CSCs and regulating their homeostasis, as shown for colon cancer (Jaeckel et al., 2018). β -catenin signaling is important for maintaining the CSC phenotype, as reported in skin cancer (Malanchi et al., 2008), and stemness (Wu et al., 2018). Overexpression of Rap1 interacting factor 1 (RIF1) (a positive regulator of the WNT/ β -catenin pathway) induces cell cycle progression to exhibit CSC-like properties in lung cancer cells (Mei, Liu, Cao, Tian, & Zhou, 2018). Mechanism of action of other factors like Forkhead box C1 (FOXC1) for inducing CSC-like properties is through upregulation of β -catenin in lung cancer cells (Cao et al., 2018). β -catenin is also the main contributor of high metastatic capacity, a characteristic of CSCs (Cao et al., 2018). A switch in the WNT to Hh is associated with progression of CSCs toward metastasis (Medema & Vermeulen, 2011). In addition, activation of the WNT signaling in cancer cells mediated by hepatocyte growth factor (HGF) released from cancer-associated fibroblasts (CAFs) is contributed to the promotion of cancer cell dedifferentiation into CSCs (Comoglio et al., 2018; Medema & Vermeulen, 2011).

4.2.1 | MEK

RAS mediated activation of Raf-MEK-ERK is cardinal for promoting CSC proliferation. CD276 (B7-H3) is a tumor-promoting glycoprotein overexpressed in CSCs. CD276 through activation of MEK can increase the size of CSC pool (Z. Liu et al., 2018).

4.3 | Notch

As mentioned, Notch pathway is related to the sustained self-renewal capacity of CSCs. Notch is activated by factors like IL-6 released by both CSCs and CAFs (Bai et al., 2018), and its suppression using antibody against its ligand delta-like ligand 4 (Dll4) in CRC has shown a reduction in the frequency of CSCs, a delay in tumor recurrence, and a decrease in the rate of metastasis (Hoey et al., 2009). Notch is also a promoter of CSC survival approved for breast cancer (Shah et al., 2018). Notch inhibitory effect on phosphatase and tensin homologue (PTEN) is necessary for the promotion of survival in such cancer. In addition, Notch promotes apoptotic resistance in CSCs possibly through activation of nuclear factor of κ B (NF- κ B) (Baker et al., 2018).

4.4 | Hedgehog

The Hh signaling is related to stem cell maintenance during embryonic development, and its hyperactivation can cause tumorigenesis in a variety of organs (Takebe et al., 2011). BMI1 as a self-renewal marker of CSCs (Goto et al., 2018) is a downstream target of the Hh signaling (Takebe et al., 2011).

Presentation of the signaling mentioned above is not mean that the other signaling pathways activated in CSCs are not important for influencing their tumorigenesis. We just presented signaling pathways that are more general for most of the cancer types. It is important to take into account other important signaling pathways in relation to cancer, such as EGFR, STAT, NF- κ B, and PI3K/AKT. For example, The PI3K/AKT and its engagement with mammalian target of rapamycin (mTOR) is reported to be in association with enhanced EMT/CSC phenotype (Chang et al., 2013) important for shaping a metastatic feature in the newly formed CSCs. Activation of NF- κ B signaling in lung cancer is reported to induce apoptotic resistance and EMT in CSCs (Zakaria et al., 2018).

5 | CSC FUNCTIONING AND CROSS-TALKING WITHIN THE TME

CSCs are reported to be responsible for sustained long-term tumor growth (Batlle & Clevers, 2017), metastasis to distant organs (Cazet et al., 2018), and an inevitable recurrence of cancer after chemo- and/or radiotherapy (Batlle & Clevers, 2017). CSCs express gene signature related to EMT, so the capacity of cancer to propagate and migrate into distant sites is considered as a silent feature of CSCs (Lytle et al., 2018). In addition, DNA mutations and TME factors possibly drive CSCs toward a metastatic phenotype (Takebe et al., 2011).

Recent progress in the recognition of the CSC phenotypic and molecular features and their cross-talking with the TME could provide a huge benefit for the development of CSC-based therapies and radical improvement in prevention of metastasis and prognosis of patients with cancer (Marquardt et al., 2018). There is no doubt that TME can spatially and temporally influence cancer cells and CSCs through complex cross-talking in a form of cell-to-cell contacts and secreted factors. Differentiated cancer cells upon exposure to the right microenvironment can retain characteristics of CSCs (Medema & Vermeulen, 2011). Cross-talking between CSCs with cells within the TME is dynamic and complex and encompass interactions between CSCs with tumor stromal cells and other non-CSCs. It is believed that CSCs reside in a smaller specialized TME subcompartment niche called CSC niche. This niche basically contains cellular and noncellular components similar to that present within the TME, including CAFs, endothelial cells (ECs), immune cells, such as tumor-associated macrophages (TAMs) as well as ECM. The TME and its CSC niche are different in each tumor type (Hermann & Sainz, 2018; D. Zhang et al., 2018). CSCs can alter cellular activity within a hypoxic TME for tumorigenic purposes. Interactions between CSCs with other stromal cells can be determined using three-dimensional culture systems (Goto et al., 2018).

5.1 | Cancer-associated fibroblast

CAFs are the main actors for shaping cancer biology, and high number of cells within a tumor is related to weak prognosis and

therapy resistance (Cazet et al., 2018). CSCs reside predominantly at the tumor edge in the close proximity to the CAFs (Lenos et al., 2018). CAFs are involved in dedifferentiation of cancer cells. This is possibly occurring through secretion of TGF- β from the cells. CAFs provide a mechanical supportive niche for the newly formed CSCs (from cancer cell dedifferentiation), which is for protecting the cells from outside influences, and thereby acquisition of a chemoresistance feature in the cells (Figure 1). To do this, CAFs would respond to Hh ligand produced by cancer cells for expression of fibroblast growth factor 5 (FGF5) and formation of fibrillary collagen. Increase in collagen content within the stroma is also correlated to the stemness and CSC properties of cancer cells. The FGF5 ligand expressed by CAFs interacts with FGFR in CSCs for mediating their stemness and chemoresistance (Cazet et al., 2018). Interestingly, CSCs have the capacity to transform into CAFs, which is for mimicking CSC niche formation. This transformation is mediated by TGF- β released from CAFs (Dianat-Moghadam et al., 2018). Activation of the FGFR signaling in CSCs initiates myofibroblast reprogramming of the cells. The reprogrammed cells could promote CSC metastatic features, and they release fibronectin to sustain the fibrogenic reprogramming of the CSCs (W. Zhang et al., 2018). CAFs also release HGF to replace FGF in sustaining long-term propagation of CSCs (Comoglio et al., 2018; Figure 1). In addition, CAFs secrete factors such as osteopontin (OPN) for regulation of CSC clonogenicity (Lenos et al., 2018). Moreover, CAFs release CXC motif ligand 12 (CXCL12; also called Stromal-cell-derived factor-1) that through interaction with its receptor CXCR4 expressed on the surface of CSCs could facilitate migration of CSCs to the metastatic sites (Bai et al., 2018; Farhood, Najafi, & Mortezaee, 2018). IL-6 is produced by both CAFs and CSCs acting in the promotion of CSC stemness, expansion, and survival (Lytle et al., 2018). IL-6 release to the TME also favors CAF growth (Bai et al., 2018).

5.2 | Endothelial cells

CSCs possibly have strong angiogenic features and are contributed to the recruitment of vessels during tumorigenesis (Gilbertson & Rich, 2007). CSCs anchored to their niche receive supportive signals via cell-to-cell contacts with ECs within the blood vessels (Lasorella et al., 2014). Glioblastoma CSCs under the influence of TGF- β are able to give rise to pericytes for supporting neovascularization and cancer growth (Cheng et al., 2013). CSCs secrete angiogenic factors vascular endothelial growth factor (VEGF) and CXCL12 to accelerate angiogenesis in ECs (Dianat-Moghadam et al., 2018). ECs, in turn, secrete factors such as nitric oxide (NO) and the CD44 ligand OPN for maintaining stem cell traits (stemness) in CSCs. NO can promote Notch signaling in the cells. Interestingly, inhibition of ECs using anti-VEGF therapy can also be tumorigenic. A possible reason is that the anti-VEGF therapy can induce hypoxia within the TME that surprisingly induce VEGF within the TME in a negative feedback loop (Gilbertson & Rich, 2007; Lytle et al., 2018). This hypoxic milieu can also block CSC differentiation (Lytle et al., 2018), increase therapy resistance of the cells (Baumann et al., 2008), and promote stem-like

features in non-CSCs (Lytle et al., 2018). In addition, ECs upregulate transmembrane protein capillary morphogenesis gene 2 (CMG2) to promote stemness, invasion and metastasis of CSCs by activation of the WNT/ β -catenin pathway shown in gastric cancer (Ji et al., 2018).

There are other cells within the TME taking important cross-talking with CSCs for progression of their tumorigenicity. There is a positive feedback loop of interaction between CSCs with M2 cells in which CSCs secrete TGF- β to stimulate M2 cells for secreting IL-37 that, in turn, potentiates self-renewal, pluripotency, and invasive features of CSCs, as shown in pancreatic cancer (Sainz et al., 2015). Likewise, CSCs secrete interferon- β to stimulate M2 cells for secretion of interferon-stimulated gene 15 (ISG15) that, in turn, reinforces self-renewal and invasiveness features of CSCs (Sainz, Martín, Tatari, Heeschen, & Guerra, 2014). CSCs also promote the education of monocytes and/or macrophages toward TAMs. The IL-6/signal transducer and activator of transcription 3 (STAT3) signaling facilitates cross-talking between CSCs and TAMs (H. Huang et al., 2018).

Natural killer (NK) cells are the key immune cells for killing CSCs by targeting the cells showing no or low rate of expression for major histocompatibility complex class I (Anja, Anahid, & Janko, 2018). CSCs are possibly more sensitive to the NK-mediated lysis than differentiated cells, evidenced for glioblastoma (Haspels, Rahman, Joseph, Navarro, & Chekenya, 2018). NK cells also limit the expansion of regulatory T lymphocytes (Tregs; Anja et al., 2018). Tregs have essential bidirectional cross-talking with CSCs for the promotion of an aggressive behavior in tumors. Upregulation of IL-4 in CSCs favors release of TGF- β to the TME for promoting Treg and myeloid-derived suppressor cell generation. IL-4 could directly impair the activity of cytotoxic T lymphocytes (CTLs; D. Zhang et al., 2018) and induce M2 polarization (Tzeng et al., 2018). In addition, IL-6 release from CSCs is important not only for sustaining their stemness (self-renewal) but also for activating Tregs, inactivating CTLs and inducing macrophage polarity toward a protumor M2-like phenotype (L. Chen et al., 2018; Kato et al., 2018; Lytle et al., 2018; Su et al., 2018). A hypoxic TME facilitates IL-6 release from CSCs by increasing the rate of expression for adenosine within the TME (Lan et al., 2018). Adenosine has been identified as a potent proinvasive factor (Siriwon et al., 2018), and it is a strong stimulator of Treg immunosuppressive activity (Ghalamfarsa et al., 2018) and a suppressor of CTLs (Y. Liu et al., 2018). Cross-talking between CSCs with other cells within TME has been shown in Figure 4.

6 | CSC TARGETING IN CANCER THERAPY

6.1 | CSC resistance to chemo/radiotherapy

CSCs are essentially account for tumor relapse (recurrence), drug resistance, and metastasis to standard chemo/radiotherapy (Batlle & Clevers, 2017), which are the principal causes of poor survival in affected patients (Z. Liu et al., 2018). The first two features are common among CSCs harvested from tissues of diverse origins (Anja et al., 2018). The preferential targets for chemo/radiotherapy are non-CSCs that make up the bulk of cancer exhibiting transient (limited)

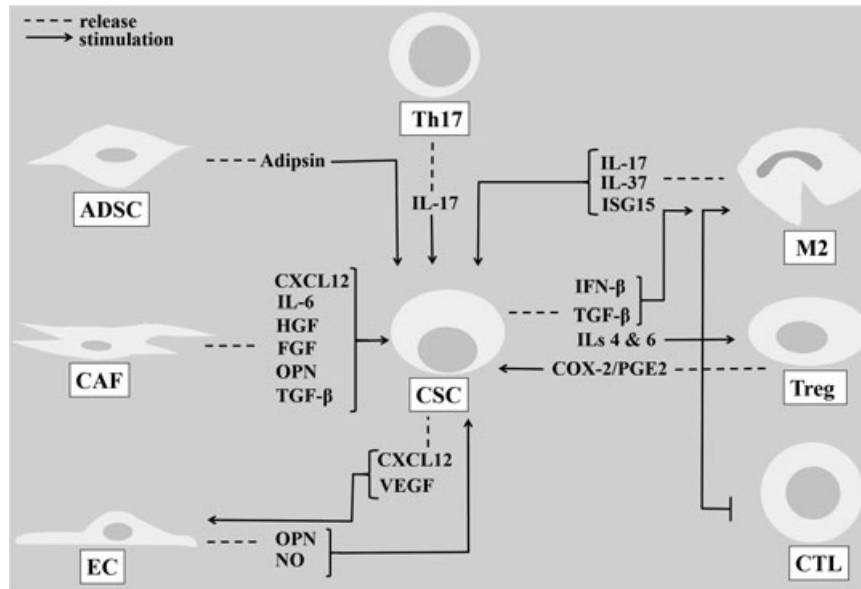

FIGURE 4 Cross-talking between cancer stem cells (CSCs) with other cells within the tumor microenvironment (TME). CSCs have positive interactions with adipose-derived stem cells (ADSCs), cancer-associated fibroblasts (CAFs), macrophage type 2 (M2) cells, regulatory T cells (Tregs), T helper (Th)17 and endothelial cells (ECs), while they have negative cross-talking with cytotoxic T lymphocytes (CTLs). COX2: cyclooxygenase 2; CXCL12: CXC motif ligand 12; FGF: fibroblast growth factor; HGF: hepatocyte growth factor; IFN: interferon; ISG: interferon-stimulated gene; NO: nitric oxide; OPN: osteopontin; PGE2: prostaglandin E2; TGF- β : transforming growth factor- β ; VEGF: vascular endothelial growth factor

proliferative rates and are not responsible for long-term tumor growth (Batlle & Clevers, 2017; Hermann & Sainz, 2018). There is evidence that residual tumors are frequently enriched with CSCs, so the cells are essentially responsible for tumor rebound after therapy (Cazet et al., 2018). CSCs remain in a quiescent state under treatment (Bai et al., 2018), which is a possible reason for more resistant nature of these cells to the targeted therapy (Visvader & Lindeman, 2008). CSCs usually reside far from cancer vessels, so the cells are not easily targeted using nanoparticle delivery of drug agents (Zuo et al., 2016). Even they are under exposure to drugs, they have efficient modalities to take less influential from these agents. CSCs express ATP-binding cassette (ABC) transporters acting as unidirectional cellular pumps that at high levels could cause resistance of the cells to chemotherapeutic drugs through increasing drug efflux, and thereby attenuating the amount of drugs accumulated within the cells (Dean et al., 2005; Dianat-Moghadam et al., 2018; Takebe et al., 2011). ABCG2 is an example of the ABC transporters expressed in CSCs, and it could be considered as an independent marker for isolation of CSCs (Bai et al., 2018). CSCs highly express antiapoptotic genes, such as BAX, BCL-2 and BIRC5, that cause resistance of these cells to apoptotic signals (Zakaria et al., 2018). The phenotypic transition may also occur in CSCs. This transition could cause changeable signaling patterns and markers in the cells reducing the efficacy of therapy (Bai et al., 2018). The resistance of CSCs to radiation therapy is another concern. The rate of resistance is differing from one tumor to another, thereby influencing radiocurability of tumors (Baumann et al., 2008). CSCs express high levels of free-radical scavengers to reduce intracellular reactive oxygen species levels generated after radiotherapy (Takebe et al., 2011), thereby high doses of radiation are possibly required for

targeting the cells (Baumann et al., 2008). The high rate of expression for ALDH and resistance-associated proteins, and uncontrolled activity of DNA repairing are other reasons for CSC resistance to treatment (Bai et al., 2018; Dianat-Moghadam et al., 2018). Constitutive activation of DNA damage response in CSCs could cause resistance to radiotherapy (Carruthers et al., 2018). Taken together, this information indicates that by application of the conventional chemo/radiotherapy we could not expect to observe a curable tumor demanding a combination of other approaches for targeting CSCs in more specific ways. Mechanisms of CSC resistance to therapy is summarized in Figure 5. An anticancer approach can cure cancer only if all CSCs are killed (Baumann et al., 2008). This is not applicable unless exploiting a combination of agents that have selective toxicity to CSCs with agents suppressing the bulk non-CSC populations or blocking conversion of non-CSCs to CSCs. This combination is important because (as aforementioned) after cessation of therapy, non-CSCs (if they are not eradicated) can regenerate CSCs and renew the growth of tumor (Gupta et al., 2011). Normal stem cells can be engineered genetically for delivery of therapeutically relevant molecules effective for targeting CSCs. For example, neural stem cells can be engineered for secretion of IL-4 for targeting CSCs and, therefore, regressing the progression of tumors (Vescovi et al., 2006).

6.2 | Modalities to overcome chemo- and/or radioresistance of CSCs

There are some modalities to make CSCs sensitive to chemo/radiotherapy. First, targeting CSC extrinsic factors, including suppression of extrinsic signaling pathways, disruption of the TME or

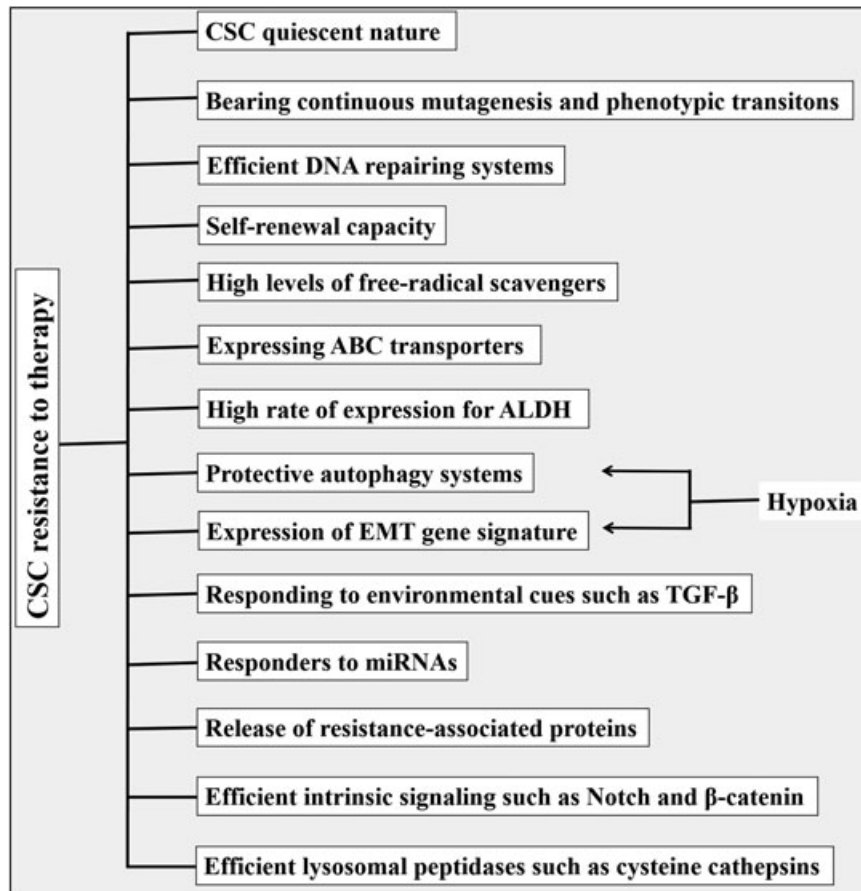

FIGURE 5 Targeting cancer stem cells (CSCs) for cancer therapies. There are a number of approaches for addressing CSCs, including targeting extrinsic factors, intrinsic factors, and control of CSC cell division. For extrinsic factors, making a control over cellular recruitment, activation or cross-talking within the tumor microenvironment (TME), or controlling hypoxia in this milieu is beneficial for reducing the number of CSCs and their stemness. For intrinsic factors, suppression of oncogene inherited markers such MET or silencing DNA binding (ID) transcriptional regulators can offer effective strategies for targeting CSCs. In addition, because heterogeneity in the CSC number per tumor is considered as an essential determinant of cancer control after therapy, switching CSCs division toward an asymmetric manner using inhibitor of related mediators, such as insulin-like growth factor 1 (IGF1) could increase the efficacy of therapy. ABC: ATP-binding cassette; ALDH: aldehyde dehydrogenase; miRNAs: microRNAs; TGF- β : transforming growth factor- β

the CSC niche within the TME is one of the promising approaches for elimination of the cells. Targeting dominant tumorigenic signaling within the TME is critical to control therapy resistance in CSCs (Lytle et al., 2018). This is because of the crucial implication of the environmental cues derived from TME in the stemness of CSCs (Ex, IL-17; Xiang et al., 2015), reinstatement (dedifferentiation) of non-CSCs into CSCs (Ex, TGF- β), resistance of CSCs (Cazet et al., 2018; Medema, 2017) and in the metastasis of the cells (Ex, cyclooxygenase 2 [COX2]/prostaglandin E2 [PGE2]; Wang et al., 2015). To reach this purpose, one or more of three available modalities can be pursued for dampening the activity of tumorigenic cells within the tumor stroma: their recruitment, activation, and cross-talking. For example, inhibition of Hh signaling can suppress CAF activation, followed by increased sensitivity of CSCs to chemotherapeutic drugs, as shown in patients with breast cancer. CAFs, unlike cancer cells, have no genomic instability, so they are less likely to acquire drug resistance over time, making the cells proper targets for cancer combination therapy (Cazet et al., 2018). CAFs secrete OPN (Lenos et al., 2018)

that is accumulated in CSCs, and there is evidence in hepatocellular carcinoma (HCC) that CSCs with high OPN levels are more sensitive to inhibitors of DNA methylation like 5-azacytidine (Gao et al., 2018). CAFs also secrete high amount of TGF- β to the TME (Farhood et al., 2018). Inhibition of TGF- β signaling using LY364947 is reported to increase the rate of CSC penetration to nanoparticles facilitating CSC therapy (Zuo et al., 2016). Another example is that interaction between M2 cells (another key cells within the TME) favors release of STAT3 to the TME (Najafi, Hashemi Goradel et al., 2018) that further renders CSC immunosuppressive profile (D. Zhang et al., 2018) and induces radioresistance in the cells (Y. Shi et al., 2018). Therefore, modalities within the TME could cause optimistic outcomes in increasing the rate of responsiveness to the chemo/radiotherapy and thereby reducing tumor burden, increasing patient survival and possibly abolishing a chance of tumor recurrence.

Hypoxia is known as a common feature of the TME (Lan et al., 2018) that is induced diversely after treatment with chemo/radiotherapy (Dianat-Moghadam et al., 2018). Hypoxia is associated with

therapy resistance in CSCs through activation of EMT genes (Lytle et al., 2018) and autophagy process (Dianat-Moghadam et al., 2018). There is a direct relation between hypoxia and ECM composition, which plays a key function in the emergence of CSCs (Marquardt et al., 2018). Hypoxia-inducible factor 1 (HIF-1) and HIF-2 α are main of hypoxia response in cancers. Activation of HIF-1 α by PI3K/AKT is contributed to the expression of the EMT modulator TWIST1. HIF2 α functions as an activator of stemness genes Sox2, OCT4 and CD44, among other (El Hout et al., 2018). CSCs have protective autophagy in which they have a controlled range of autophagy required for promoting their survival (Talukdar et al., 2018b). Hypoxia through activation of autophagy process in CSCs is able to compensate ATP deficiency, to provide metabolic nutrients, to promote survival in CSCs, and to upregulate stemness genes (Dianat-Moghadam et al., 2018). The protective autophagy process in CSCs is for promoting their resistance to anoikis that is considered as a form of programmed cell death occurring after detachment of anchorage-dependent cells from the ECM (Talukdar et al., 2018a). Autophagy in CSCs can be targeted by either inhibition of this process (Baquero et al., 2018) or by its overactivation (Talukdar et al., 2018b). There is compelling evidence for the efficacy of autophagy inhibitors for suppression of CSCs in tumors like leukemia (Baquero et al., 2018). Overactivation of autophagy can initiate a toxic autophagy process reducing the rate of survival in CSCs (Talukdar et al., 2018b). Hypoxia-inducible effect on autophagy and further replenishing for ATP is related to the efflux of drugs from CSCs, as mentioned before. It is also important to note that chemotherapeutic agent when encounter a hypoxic condition could diversely cause CSC enrichment through regulation mitogen-activated protein kinase signaling. This regulation is mediated by the inhibition of ERK and activation of p38 signaling for respective induction and stabilization of pluripotency factors in the CSCs (Lu et al., 2018). Radiotherapy also indirectly induces expression of HIF-1 α (X. Chen et al., 2018). Therefore, it is suggested to apply a reoxygenation strategy or using HIF-1 inhibitors in combination with chemotherapy or radiotherapy to induce chemo/radio sensitization and abolish CSC enrichment (X. Chen et al., 2018; Lu et al., 2018). The reoxygenation possibly allows differentiation of CSCs. When the cells are committed to differentiation, they cannot initiate tumor growth because the cells in the stem cell state can fuel tumor growth (not after differentiation) (Baumann et al., 2008; Medema, 2017). In addition, when committed to differentiation, CSCs would take out of their stem cell pool and thereby will be prone to be killed by the application of therapeutic approaches (Baumann et al., 2008).

It seems that targeting TME would offer optimistic outcomes for suppressing both CSCs and non-CSCs and their interplay. Targeting both of the cell types is important for effective therapeutic purposes because there is evidence for the niche refilling by new CSCs derived from cancer cells after the killing of preexisting CSCs in colon cancer (Shimokawa et al., 2017). Modulation within the TME would hamper non-CSC-to-CSC conversion that probably provides a proper combination with drugs sensitizes CSCs. The niche containing CSCs and the vascular bed can be disrupted to expose both CSCs and cancer cells to the cytotoxic effects of conventional chemotherapy

(Gilbertson & Rich, 2007). Increase in the sensitivity of CSCs to chemotherapeutic drugs can be pursued using nonsteroid anti-inflammatory drugs (NSAIDs) like aspirin. Aspirin induces the fas ligand (FasL) pathway of apoptosis in CSCs of patients with CRC without affecting non-CSCs, so NSAIDs can possibly be served as effective adjuvant therapy for cancer (Z. Chen et al., 2018). Although efficacy of NSAIDs in tumor-targeted therapies has been approved, for potentiating the effectiveness of cancer combination therapies choosing proper chemotherapeutic drugs that are specific for a tumor type is a preferred option.

CSC niche is a nutrient-deprived milieu causing high dependency of CSCs to mitochondrial oxidative phosphorylation (OXPHOS) to meet the energy requirement of the cells (Hermann & Sainz, 2018). CSCs highly rely on lipid metabolism to satisfy their energy demands (Yi et al., 2018), so metabolic reprogramming of the TME or CSC niche may be another strategy for reducing the number of these cells (Hermann & Sainz, 2018). In addition, circadian clock in the TME would make a control over the circadian dynamics of CSCs. This regulation is probably important for inhibition of CSC overproduction. The CSC circadian dynamic explains presumable variations in efficacy of anticancer drugs (Matsunaga et al., 2018). Therefore, to make a regulation over TME and suppress cancer progression, it is important to re-establish circadian rhythm within this milieu (Alvarez-García, González, Alonso-González, Martínez-Campa & Cos, 2013; Mortezaee, 2018).

Second, direct target of CSC intrinsic factors is another way to overcome therapy resistance (Lytle et al., 2018). For example, MET signaling can be targeted in CSCs to control their clonogenic features by transforming them toward radiosensitive nonstem cells. MET initiates signaling pathways in CSCs resulting in their increased DNA repair and survival, and thereby fostering their radioresistance (Comoglio et al., 2018; Lenos et al., 2018). Targeting Notch as a factor for promoting self-renewal and survival in CSCs is another promising strategy to remove drug resistance in the cells (Shah et al., 2018). Mutations in the p53 gene can bear a CSC phenotypic feature in normal stem cells within tissues and organs, so knockdown of this mutant p53 can reduce the frequency of the tumorigenic cells (Koifman et al., 2018). For example, mutations in p53 may cause high expression of CD44 in breast CSCs for the promotion of survival in the cells (Bai et al., 2018). Developing monoclonal antibodies against CD44 could be used as a promising strategy for the selective elimination of self-renewal potential in CSCs (Marquardt et al., 2018). In prostate cancer, p53 is reported to contribute to suppression of stemness and metastasis in CSCs via downregulation of CD51 in the cells, so activation of CD51 could be a therapeutic target for restricting progression of prostate cancer (Sui et al., 2018).

Targeting CSC markers by inserting apoptotic-related genes to the gene locus of the markers can also be hopeful. For example, version of the suicide-gene caspase-9 can be inserted into the Lgr5 locus for elimination of Lgr5⁺ CSCs in human CRC (Hermann & Sainz, 2018). The next target could be on cysteine cathepsins that are lysosomal peptidases upregulated in CSCs and are considered as mediators of CSC resistance to apoptotic signals (Anja et al., 2018).

Another approach to overcome CSC resistance to therapy is by targeting MEK signaling through blocking its activators, such as B7-H3, a tumor-promoting glycoprotein overexpressed in various types of cancers and is related to drug resistance through enrichment of CSC population (Z. Liu et al., 2018). Stemness markers can be a target for hormonal therapy like melatonin, a potent oxidative/antioxidative hormone with known anticancer properties (J.H. Lee et al., 2018; Mortezaee & Khanlarkhani, 2018). Melatonin through activation of melatonin receptor 1 (MT1) receptor can suppress stemness and promote sensitivity of CSCs to chemotherapy, as reported in brain cancer (H. Lee, Lee, Jung, Shin, & Kim, 2018). The stemness markers can be activated in cancer cells after exposure to environmental insults. For example, it has been proven in pancreatic cancer that exposure to nicotine could activate RAF1 in cancer cells for the promotion of their stemness (Nimmakayala et al., 2018), so it is suggestive to avoid exposure to environmental hazards to prevent the progression of cancer in affected patients. β -catenin signaling can be suppressed in CSCs using inhibitors for increasing the efficacy of chemotherapeutic drugs. For example, suppression of β -catenin using inhibitors for cyclin-dependent kinase 1 (CDK1; a protein kinase important for cellular transitions of G1/S and G2/M phases) is reported to overcome the resistance of CSCs to sorafenib in HCC (Wu et al., 2018). A point to consider is that the β -catenin pathway is indirectly reactivated after prolong application of PI3K inhibitors for patients with cancer (evidenced in HCC), so percussion is necessary for the administration of such therapies (F. Liu, Wu, Jiang, Qian, &

Gao, 2018). Moreover, microRNA (miRNA) contribution to the regulation of CSC biology is needed to be under consideration. MiRNAs mediate aberrant epigenetic regulation over CSCs and play important roles in CSC-related EMT, metastasis, angiogenesis, and drug resistance. To do these functions, miRNAs regulate p53 gene expression profile, and that they have interactions with the key signaling pathways in CSC tumorigenesis such as WNT, TGF- β , and PI3K/AKT. Identifying these miRNAs in cancers and targeting them is important not only for designing therapeutic protocols but also for diagnosis of cancer. For example, miRNA-21 has been identified as a biomarker for the diagnosis of CRC (De Robertis et al., 2018), and enforced expression of miR-34a (a p53 target) in prostate cancer can inhibit clonogenic expression of CSCs and suppression of their regeneration and related metastasis (C. Liu et al., 2011). Small interfering RNA could also be applied. For example, siAKT2 is reported to be effective in impairing CSC-mediated breast tumor recurrence (Rafael et al., 2018).

Third, as it has been discussed before, disruption of asymmetric division in CSCs occur upon tumor progression, which is for expanding the number of the cells within a tumor (Lytle et al., 2018). Heterogeneity in the CSC number per tumor is an essential determinant of cancer control following therapy (Baumann et al., 2008). Therefore, increase in the asymmetric division can be served as an approach to halt the aggressive progression of cancer (Lytle et al., 2018). For example, for mouse lung cancer, the relevance between high insulin-like growth factor 1 with the initiation of CSC

TABLE 2 Cancer type dependent therapeutic targeting against cancer stem cells (CSCs) harvested from human cancerous tissues

Agent type	Mechanism	Cancer type	References
MiR-4319	Regulation of CSC tumorigenesis and self-renewal	Breast	Chu et al. (2018)
MiR-141	Suppression of prometastatic genes in CSCs	Prostate	C. Liu, Liu et al. (2017)
Luteolin	Luteolin is a common dietary flavonoid that acts through inhibition of WNT signaling by upregulation of FZD6 transcription	Prostate	Han et al. (2018)
MiR-34a	Direct repression of CD44 in CSCs	Prostate	C. Liu et al. (2011)
MiR-18a-5p	Downregulation of HIF-1 α	Lung	X. Chen et al. (2018)
USP22 block	Downregulation of ALDH1	Lung	Yun et al. (2018)
BMS-345541	BMS-345541 is an NF- κ B inhibitor that suppresses EMT and apoptotic resistance in CSCs	Lung	Zakaria et al. (2018)
Regorafenib	Potentiating the activity of the tumor suppressor miR-34a	Colon	Cai et al. (2018)
MiR-195-5p	Suppression of CSC stemness	CRC	Jin et al. (2018)
Ibrutinib	Inactivation of BMX-STAT3	Glioma	Y. Shi et al. (2018)
AMG232	MDM2 inhibitor. MDM2 is an E3 ubiquitin ligase that is responsible for destabilization and negatively regulation of the p53 protein	Glioblastoma	Her et al. (2018)
Anti-ABCG2	ABCG2 is a transmembrane protein acting as ABC transporters for unidirectional efflux of chemotherapeutic drugs	MM	F. Shi et al. (2018)
WYC-209	WYC-209 is a synthetic retinoid that induces apoptosis in CSCs	Melanoma, lung, and breast	J. Chen et al. (2018)
ACR	Suppression of the WNT/ β -catenin pathway in CSCs	HCC	Qin et al. (2018)

Note. ABC: ATP-binding cassette; ACR: acyclic retinoid; ALDH: aldehyde dehydrogenase; BMX: bone marrow and X-linked; CRC: colorectal cancer; CSC: cancer stem cell; EMT: epithelial-mesenchymal transition; FZD6: frizzled class receptor 6; HCC: hepatocellular carcinoma; HIF-1 α : hypoxia-inducible factor-1; MDM2: murine double minute 2 gene; MM: multiple myeloma; NF- κ B: nuclear factor of κ B; STAT3: signal transducer and activator of transcription 3; USP22: ubiquitin specific peptidase 22.

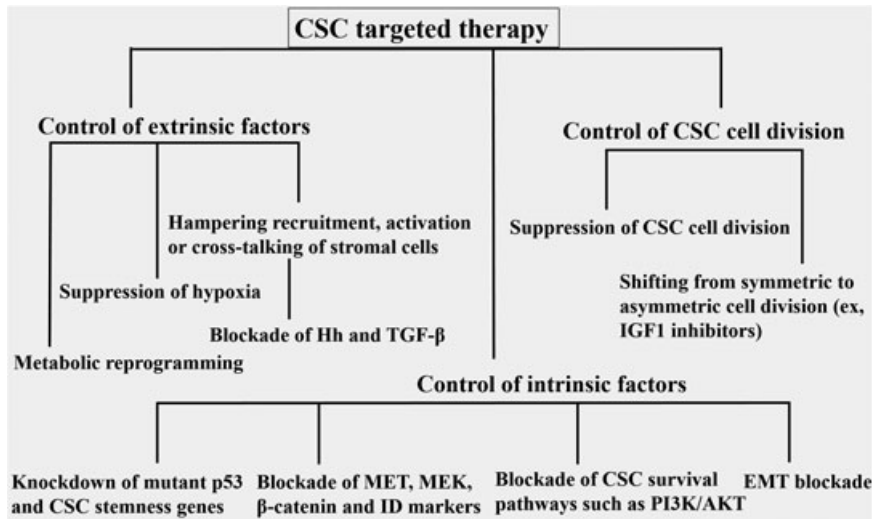

FIGURE 6 Therapeutic approaches for targeting cancer stem cells (CSCs). EMT: epithelial–mesenchymal transition; Hh: Hedgehog; IGF1: insulin-like growth factor 1; MEK: mitogen-activated protein kinase; P12K/AKT: phosphatidylinositol 3-kinase; TGF- β : transforming growth factor- β

self-renewal from asymmetry to symmetry through activation of the PI3K/AKT/ β -catenin and the subsequent recurrence of the tumor has been elucidated (Li et al., 2018). So, acknowledging the roles of such mediators or related pathways for cancers can provide a promising approach for reducing the risk of tumor relapse.

Fourth, CSCs can be targeted by immunotherapeutic approaches including immune checkpoint blockade (ICB), monoclonal antibodies, vaccination, T cell therapy, and activation of innate immune responses, such as NK cells (D. Zhang et al., 2018). CSCs have developed a myriad of ways to circumvent a possible attack from the immune system, including loss of cancer antigen expression, activation of oncolytic pathways, and promotion of an immunosuppressive milieu and (epi) genetic alterations that cause their reduced recognition by the immune system (D. Zhang et al., 2018). These immunotherapeutic approaches can offer a potential targeting for increasing the sensitivity of CSCs to chemo- and/or radiotherapy. ICB approaches, for example, can revoke the activity of CSCs and other immunosuppressive cells within the TME. CSCs (Dianat-Moghadam et al., 2018) and cancer cells (Mortezaee, 2018) produce programmed death-1 ligand (PD-L1), and its receptor PD-1 is expressed by Tregs (Zappasodi et al., 2018). CSCs also release PD-1 to their niche (D. Zhang et al., 2018). PD-L1 could cause exhaustion and dysfunction of effector T cells (Du et al., 2018) and restriction of CSC immune escaping. A point here is to apply immunotherapeutic approaches for unique CSC markers and antigens preferentially expressed by the cells (D. Zhang et al., 2018). In Table 2, agents used for targeting CSCs in various human cancers has been described focusing on the mechanisms involved in exerting their therapeutic efficacy, and in Figure 6, strategies for targeting CSCs are summarized.

7 | CONCLUSION AND PERSPECTIVE

The information provided in this review is mostly from the evaluation of CSCs in vitro and from xenograft data, and it followed a rather holistic overview toward cancer, so it has not pertained to all types of

cancers. Human tumoral tissues engrafted to the immune compromised animals may experience different responses to the environmental cues from animals, and that the level of functionality of CSCs is possibly differ from one cancer to another, or even the grade of one specific tumor may cause a noticeable effect on CSC functionality. In fact, tumors at early stages have lower genetic aberrations, lower TME potential to influence CSCs, and possibly fewer number of the cells compared with the established tumors. CSCs from different tissue origins exhibit different cell surface glycoproteins and have diverse requirements for their growth and maintenance (Anja et al., 2018). For targeting cancer in the clinic, there is an urgent need for cancer type basis of CSC identification and sensitivity and selective killing of the cells to expect more accurate responses, and due to the existence of different population of CSCs within a type of tumor (da Silva-Diz et al., 2018), isolation of the cells must be carried out by targeting different markers for the cells (not just one marker).

It is still unclear whether a CSC that can cause tumor initiation is the same as a CSC that can cause tumor relapse after chemo/radiotherapy. There are also burning issues regarding the density of the cells and their spatial distribution. Although it has been reported a high amount of the CSCs remained in residual tumors (Cazet et al., 2018), the frequency of these cells for many tumors is low (almost 1/1,000 cells) demanding power purification approaches (that are not yet extensively available) for isolation of the cells (Nguyen et al., 2012), thereby limiting development of drugs and treatment strategies (Takebe et al., 2011). In addition, it is unknown whether markers discussed before have the properties of bona fide CSCs, and that their specificity and the stability of expression in the CSCs over time of exhibiting their stem-like properties is another issue needing further research to design therapeutic protocols more specifically on the cells, as it is approved that inactivation of all CSCs is required for permanent local cancer control (Baumann et al., 2008).

CONFLICTS OF INTEREST

The authors declare that there are no conflicts of interest.

ORCID

Keywan Mortezaee  <http://orcid.org/0000-0003-2004-3465>

REFERENCES

- Alvarez-García, V., González, A., Alonso-González, C., Martínez-Campa, C., & Cos, S. (2013). Regulation of vascular endothelial growth factor by melatonin in human breast cancer cells. *Journal of Pineal Research*, 54(4), 373–380.
- Anja, P., Anahid, J., & Janko, K. (2018). Cysteine cathepsins: Their biological and molecular significance in cancer stem cells. *Seminars in Cancer Biology*, 64, e12519.
- Bai, X., Ni, J., Beretov, J., Graham, P., & Li, Y. (2018). Cancer stem cell in breast cancer therapeutic resistance. *Cancer Treatment Reviews*, 69, 152–163.
- Baker, A., Wyatt, D., Bocchetta, M., Li, J., Filipovic, A., Green, A., ... Osipo, C. (2018). Notch-1-PTEN-ERK1/2 signaling axis promotes HER2+breast cancer cell proliferation and stem cell survival. *Oncogene*, 37, 4489–4504.
- Baquero, P., Dawson, A., Mukhopadhyay, A., Kuntz, E. M., Mitchell, R., Olivares, O., ... Helgason, G. V. (2018). Targeting quiescent leukemic stem cells using second generation autophagy inhibitors. *Leukemia*, <https://doi.org/10.1038/s41375-018-0252-4>
- Batlle, E., & Clevers, H. (2017). Cancer stem cells revisited. *Nature Medicine*, 23(10), 1124–1134.
- Baumann, M., Krause, M., & Hill, R. (2008). Exploring the role of cancer stem cells in radioresistance. *Nature Reviews Cancer*, 8(7), 545–554.
- Cai, M.-H., Xu, X.-G., Yan, S.-L., Sun, Z., Ying, Y., Wang, B.-K., & Tu, Y.-X. (2018). Regorafenib suppresses colon tumorigenesis and the generation of drug resistant cancer stem-like cells via modulation of miR-34a associated signaling. *Journal of Experimental & Clinical Cancer Research*, 37(1), 151.
- Cao, S., Wang, Z., Gao, X., He, W., Cai, Y., Chen, H., & Xu, R. (2018). FOXC1 induces cancer stem cell-like properties through upregulation of beta-catenin in NSCLC. *Journal of Experimental & Clinical Cancer Research*, 37(1), 220.
- Carruthers, R. D., Ahmed, S. U., Ramachandran, S., Strathdee, K., Kurian, K. M., Hedley, A., ... Chalmers, A. J. (2018). Replication stress drives constitutive activation of the DNA damage response and radioresistance in glioblastoma stem-like cells. *Cancer Research*, 78(17), 5060–5071.
- Cazet, A. S., Hui, M. N., Elsworth, B. L., Wu, S. Z., Roden, D., Chan, C.-L., ... Swarbrick, A. (2018). Targeting stromal remodeling and cancer stem cell plasticity overcomes chemoresistance in triple negative breast cancer. *Nature Communications*, 9, 2897.
- Chaffer, C. L., Brueckmann, I., Scheel, C., Kaestli, A. J., Wiggins, P. A., Rodrigues, L. O., ... Weinberg, R. A. (2011). Normal and neoplastic nonstem cells can spontaneously convert to a stem-like state. *Proceedings of the National Academy of Sciences of the United States of America*, 108(19), 7950–7955.
- Chaffer, C. L., Marjanovic, N. D., Lee, T., Bell, G., Kleer, C. G., Reinhardt, F., ... Weinberg, R. A. (2013). Poised chromatin at the ZEB1 promoter enables breast cancer cell plasticity and enhances tumorigenicity. *Cell*, 154(1), 61–74.
- Chang, L., Graham, P. H., Hao, J., Ni, J., Bucci, J., Cozzi, P. J., ... Li, Y. (2013). Acquisition of epithelial-mesenchymal transition and cancer stem cell phenotypes is associated with activation of the PI3K/Akt/mTOR pathway in prostate cancer radioresistance. *Cell Death & Disease*, 4(10), e875.
- Chen, C., Okita, Y., Watanabe, Y., Abe, F., Fikry, M. A., Ichikawa, Y., ... Kato, M. (2018). Glycoprotein nmb is exposed on the surface of dormant breast cancer cells and induces stem cell-like properties. *Cancer Research*, <https://doi.org/10.1158/0008-5472.CAN-18-0599>
- Chen, J., Cao, X., An, Q., Zhang, Y., Li, K., Yao, W., ... Yu, B. (2018). Inhibition of cancer stem cell like cells by a synthetic retinoid. *Nature Communications*, 9(1), 1406.
- Chen, L., Wang, S., Wang, Y., Zhang, W., Ma, K., Hu, C., ... Xu, N. (2018). IL-6 influences the polarization of macrophages and the formation and growth of colorectal tumor. *Oncotarget*, 9(25), 17443.
- Chen, X., Wu, L., Li, D., Xu, Y., Zhang, L., Niu, K., ... Sun, J. (2018). Radiosensitizing effects of miR-18a-5p on lung cancer stem-like cells via downregulating both ATM and HIF-1 α . *Cancer Medicine*, 7, 3834–3847.
- Chen, Z., Li, W., Qiu, F., Huang, Q., Jiang, Z., Ye, J., ... Huang, J. (2018). Aspirin cooperates with p300 to activate the acetylation of H3K9 and promote FasL-mediated apoptosis of cancer stem-like cells in colorectal cancer. *Theranostics*, 8(16), 4447–4461.
- Cheng, L., Huang, Z., Zhou, W., Wu, Q., Donnola, S., Liu, J. K., ... Bao, S. (2013). Glioblastoma stem cells generate vascular pericytes to support vessel function and tumor growth. *Cell*, 153(1), 139–152.
- Chu, J., Li, Y., Fan, X., Ma, J., Li, J., Lu, G., ... Yuan, H. (2018). MIR-4319 suppress the malignancy of triple-negative breast cancer by regulating self-renewal and tumorigenesis of stem cells. *Cellular Physiology and Biochemistry*, 48(2), 593–604.
- Comoglio, P. M., Trusolino, L., & Boccaccio, C. (2018). Known and novel roles of the MET oncogene in cancer: A coherent approach to targeted therapy. *Nature Reviews Cancer*, 18, 341–358.
- da Silva-Diz, V., Lorenzo-Sanz, L., Bernat-Peguer, A., Lopez-Cerda, M., & Muñoz, P. (2018). Cancer cell plasticity: Impact on tumor progression and therapy response. *Seminars in Cancer Biology*, <https://doi.org/10.1016/j.semcancer.2018.08.009>
- De Robertis, M., Poeta, M. L., Signori, E., & Fazio, V. M. (2018). Current understanding and clinical utility of miRNAs regulation of colon cancer stem cells. *Seminars in Cancer Biology*, <https://doi.org/10.1016/j.semcancer.2018.08.008>
- Dean, M., Fojo, T., & Bates, S. (2005). Tumour stem cells and drug resistance. *Nature Reviews Cancer*, 5(4), 275–284.
- Dianat-Moghadam, H., Heydarifard, M., Jahanban-Esfahlan, R., Panahi, Y., Hamishehkar, H., Pouremamali, F., ... Nouri, M. (2018). Cancer stem cells-emanated therapy resistance: Implications for liposomal drug delivery systems. *Journal of Controlled Release*, 288, 62–83.
- Du, X., Tang, F., Liu, M., Su, J., Zhang, Y., Wu, W., ... Liu, Y. (2018). A reappraisal of CTLA-4 checkpoint blockade in cancer immunotherapy. *Cell Research*, 28(4), 416–432.
- El Hout, M., Dos Santos, L., Hamaï, A., & Mehrpour, M. (2018). A promising new approach to cancer therapy: Targeting iron metabolism in cancer stem cells. *Seminars in Cancer Biology*, <https://doi.org/10.1016/j.semcancer.2018.07.009>
- Farhood, B., Najafi, M., & Mortezaee, K. (2018). Cancer-associated fibroblasts: Secretions, interactions, and therapy. *Journal of Cellular Biochemistry*, <https://doi.org/10.1002/jcb.27703>
- Gao, X., Sheng, Y., Yang, J., Wang, C., Zhang, R., Zhu, Y., ... Sun, H. (2018). Osteopontin alters DNA methylation through up-regulating DNMT1 and sensitizes CD133+/CD44+cancer stem cells to 5 azacytidine in hepatocellular carcinoma. *Journal of Experimental & Clinical Cancer Research*, 37(1), 179.
- Ghalamfarsa, G., Rastegari, A., Atyabi, F., Hassannia, H., Hojjat-Farsangi, M., Ghanbari, A., ... Jadidi-Niaragh, F. (2018). Anti-angiogenic effects of CD73-specific siRNA-loaded nanoparticles in breast cancer-bearing mice. *Journal of Cellular Physiology*, 233, 7165–7177.
- Gilbertson, R. J., & Rich, J. N. (2007). Making a tumour's bed: Glioblastoma stem cells and the vascular niche. *Nature Reviews Cancer*, 7(10), 733–736.
- Golan, H., Shukrun, R., Caspi, R., Vax, E., Pode-Shakked, N., Goldberg, S., ... Dekel, B. (2018). In vivo expansion of cancer stemness affords novel cancer stem cell targets: Malignant rhabdoid tumor as an example. *Stem Cell Reports*, 11(3), 795–810.
- Goto, H., Shimono, Y., Funakoshi, Y., Imamura, Y., Toyoda, M., Kiyota, N., ... Minami, H. (2018). Adipose-derived stem cells enhance human breast cancer growth and cancer stem cell-like properties through adipin. *Oncogene*, <https://doi.org/10.1038/s41388-018-0477-8>

- Gupta, P. B., Fillmore, C. M., Jiang, G., Shapira, S. D., Tao, K., Kuperwasser, C., & Lander, E. S. (2011). Stochastic state transitions give rise to phenotypic equilibrium in populations of cancer cells. *Cell*, *146*(4), 633–644.
- Han, K., Lang, T., Zhang, Z., Zhang, Y., Sun, Y., Shen, Z., ... Min, D. (2018). Luteolin attenuates Wnt signaling via upregulation of FZD6 to suppress prostate cancer stemness revealed by comparative proteomics. *Scientific Reports*, *8*(1), 8537.
- Haspels, H. N., Rahman, M. A., Joseph, J. V., Gras navarro, A., & Chekenya, M. (2018). Glioblastoma stem-like cells are more susceptible than differentiated cells to NK cell lysis mediated through KIR-HLA ligand mismatch and activation receptor-ligand interactions. *Frontiers in Immunology*, *9*, 1345.
- Her, N.-G., Oh, J.-W., Oh, Y. J., Han, S., Cho, H. J., Lee, Y., ... Nam, D.-H. (2018). Potent effect of the MDM2 inhibitor AMG232 on suppression of glioblastoma stem cells. *Cell Death & Disease*, *9*, 8:792–804.
- Hermann, P. C., & Sainz, B., Jr (2018). Pancreatic cancer stem cells: A state or an entity? *Seminars in Cancer Biology*, <https://doi.org/10.1016/j.semcancer.2018.08.007>
- Hoey, T., Yen, W. -C., Axelrod, F., Basi, J., Donigian, L., Dylla, S., ... Gurney, A. (2009). DLL4 blockade inhibits tumor growth and reduces tumor-initiating cell frequency. *Cell Stem Cell*, *5*(2), 168–177.
- Huang, E. H., Hynes, M. J., Zhang, T., Ginestier, C., Dontu, G., Appelman, H., ... Boman, B. M. (2009). Aldehyde dehydrogenase 1 is a marker for normal and malignant human colonic stem cells (SC) and tracks SC overpopulation during colon tumorigenesis. *Cancer Research*, *69*(8), 3382–3389.
- Huang, H., Wang, C., Liu, F., Li, H. Z., Peng, G., Gao, X., ... Sun, Y. H. (2018). Reciprocal network between cancer stem-like cells and macrophages facilitates the progression and androgen deprivation therapy resistance of prostate cancer. *Clinical Cancer Research*, *24*, 4612–4626.
- Iliopoulos, D., Hirsch, H.A., Wang, G., & Struhl, K. (2011). Inducible formation of breast cancer stem cells and their dynamic equilibrium with non-stem cancer cells via IL6 secretion. *108*, 1397–1402.
- Jaeckel, S., Kaller, M., Jackstadt, R., Götz, U., Müller, S., Boos, S., ... Hermeking, H. (2018). Ap4 is rate limiting for intestinal tumor formation by controlling the homeostasis of intestinal stem cells. *Nature Communications*, *9*(1), 3573.
- Ji, C., Yang, L., Yi, W., Xiang, D., Wang, Y., Zhou, Z., ... Bian, X. (2018). Capillary morphogenesis gene 2 maintains gastric cancer stem-like cell phenotype by activating a Wnt/ β -catenin pathway. *Oncogene*, *37*, 3953–3966.
- Jin, Y., Wang, M., Hu, H., Huang, Q., Chen, Y., & Wang, G. (2018). Overcoming stemness and chemoresistance in colorectal cancer through miR-195-5p-modulated inhibition of notch signaling. *International Journal of Biological Macromolecules*, *117*, 445–453.
- Kato, T., Noma, K., Ohara, T., Kashima, H., Katsura, Y., Sato, H., ... Tazawa, H. (2018). Cancer-associated fibroblasts affect intratumoral CD8+ and FoxP3+ T cells via Interleukin 6 in the tumor microenvironment. *Clinical Cancer Research*, *24*, 4820–4833.
- Koifman, G., Shetzer, Y., Eizenberger, S., Solomon, H., Rotkopf, R., Molchadsky, A., ... Rotter, V. (2018). A mutant p53-dependent embryonic stem cell gene signature is associated with augmented tumorigenesis of stem cells. *Cancer Research*, *78*, 5833–5847.
- Lan, J., Lu, H., Samanta, D., Salman, S., Lu, Y., & Semenza, G.L. Hypoxia-inducible factor 1-dependent expression of adenosine receptor 2B promotes breast cancer stem cell enrichment. *Proceedings of the National Academy of Sciences of the United States of America*, *115*, E9640–E9648.
- Lasorella, A., Benezra, R., & Iavarone, A. (2014). The ID proteins: Master regulators of cancer stem cells and tumour aggressiveness. *Nature Reviews Cancer*, *14*(2), 77–91.
- Lee, H., Lee, H.J., Jung, J.H., Shin, E.A., & Kim, S.H. (2018). Melatonin disturbs SUMOylation-mediated crosstalk between c-Myc and nestin via MT 1 activation and promotes the sensitivity of paclitaxel in brain cancer stem cells. *Journal of Pineal Research*, *65*, e12496.
- Lee, J.H., Yun, C.W., Han, Y.S., Kim, S., Jeong, D., Kwon, H.Y., ... Lee, S.H. (2018). Melatonin and 5-fluorouracil co-suppress colon cancer stem cells by regulating cellular prion protein-Oct4 axis. *Journal of Pineal Research*, *65*, e12519.
- Lenos, K. J., Miedema, D. M., Lodestijn, S. C., Nijman, L. E., van den Bosch, T., Romero ros, X., ... Vermeulen, L. (2018). Stem cell functionality is microenvironmentally defined during tumour expansion and therapy response in colon cancer. *Nature Cell Biology*, *20*, 1193–1202.
- Li, L., Li, J.-C., Yang, H., Zhang, X., Liu, L.-L., Li, Y., ... Xie, D. (2018). Expansion of cancer stem cell pool initiates lung cancer recurrence before angiogenesis. *Proceedings of the National Academy of Sciences of the United States of America*, *115*, E8948–E8957.
- Liu, C., Kelnar, K., Liu, B., Chen, X., Calhoun-Davis, T., Li, H., ... Tang, D. G. (2011). The microRNA miR-34a inhibits prostate cancer stem cells and metastasis by directly repressing CD44. *Nature Medicine*, *17*(2), 211–215.
- Liu, C., Liu, R., Zhang, D., Deng, Q., Liu, B., Chao, H. -P., ... Tang, D. G. (2017). MicroRNA-141 suppresses prostate cancer stem cells and metastasis by targeting a cohort of pro-metastasis genes. *Nature Communications*, *8*, 14270.
- Liu, F., Wu, X., Jiang, X., Qian, Y., & Gao, J. (2018). Prolonged inhibition of class I PI3K promotes liver cancer stem cell expansion by augmenting SGK3/GSK-3 β -catenin signalling. *Journal of Experimental & Clinical Cancer Research*, *37*(1), 122.
- Liu, Y., Geng, Y.-H., Yang, H., Yang, H., Zhou, Y.-T., Zhang, H.-Q., ... Fang, W.-G. (2018). Extracellular ATP drives breast cancer cell migration and metastasis via S100A4 production by cancer cells and fibroblasts. *Cancer Letters*, *430*, 1–10.
- Liu, Z., Zhang, W., Phillips, J. B., Arora, R., McClellan, S., Li, J., ... Tan, M. (2018). Immunoregulatory protein B7-H3 regulates cancer stem cell enrichment and drug resistance through MVP-mediated MEK activation. *Oncogene*, <https://doi.org/10.1038/s41388-018-0407-9>
- Lu, H., Tran, L., Park, Y., Chen, I., Lan, J., Xie, Y., & Semenza, G. L. (2018). Reciprocally regulation of DUSP9 and DUSP16 expression by HIF-1 controls ERK and p38 MAP kinase activity and mediates chemotherapy-induced breast cancer stem cell enrichment. *Cancer Research*, *78*, 4191–4202.
- Lytle, N. K., Barber, A. G., & Reya, T. (2018). Stem cell fate in cancer growth, progression and therapy resistance. *Nature Reviews Cancer*, *18*(1), 669–680.
- Malanchi, I., Peinado, H., Kassen, D., Hussenet, T., Metzger, D., Chambon, P., ... Huelsken, J. (2008). Cutaneous cancer stem cell maintenance is dependent on β -catenin signalling. *Nature*, *452*(7187), 650–653.
- Marquardt, S., Solanki, M., Spitschak, A., Vera, J., & Pützer, B. M. (2018). Emerging functional markers for cancer stem cell-based therapies: Understanding signaling networks for targeting metastasis. *Seminars in Cancer Biology*, <https://doi.org/10.1016/j.semcancer.2018.06.006>
- Matsunaga, N., Ogino, T., Hara, Y., Tanaka, T., Koyanagi, S., & Ohdo, S. (2018). Optimized dosing schedule based on circadian dynamics of mouse breast cancer stem cells improves the anti-tumor effects of aldehyde dehydrogenase. *Cancer Research*, *78*, 3698–3708.
- Medema, J. P. (2017). Targeting the colorectal cancer stem cell. *New England Journal of Medicine*, *377*(9), 888–890.
- Medema, J. P., & Vermeulen, L. (2011). Microenvironmental regulation of stem cells in intestinal homeostasis and cancer. *Nature*, *474*(7351), 318–326.
- Mei, Y., Liu, Y.-B., Cao, S., Tian, Z.-W., & Zhou, H.-H. (2018). RIF1 promotes tumor growth and cancer stem cell-like traits in NSCLC by protein phosphatase 1-mediated activation of Wnt/ β -catenin signaling. *Cell Death & Disease*, *9*(10), 942.
- Mortezaee, K. (2018). Human hepatocellular carcinoma: Protection by melatonin. *Journal of Cellular Physiology*, *233*, 6486–6508.
- Mortezaee, K., & Khanlarkhani, N. (2018). Melatonin application in targeting oxidative-induced liver injuries: A review. *Journal of Cellular Physiology*, *233*(5), 4015–4032.
- Najafi, M., Hashemi Goradel, N., Farhood, B., Salehi, E., Nashtaei, M. S., Khanlarkhani, N., ... Mortezaee, K. (2018). Macrophage polarity in cancer: A review. *Journal of Cellular Biochemistry*, <https://doi.org/10.1002/jcb.27646>

- Najafi, M., Salehi, E., Farhood, B., Nashtaei, M. S., Hashemi Goradel, N., Khanlarkhani, N., ... Mortezaee, K. (2018). Adjuvant chemotherapy with melatonin for targeting human cancers: A review. *Journal of Cellular Physiology*, <https://doi.org/10.1002/jcp.27259>
- Nakano, M., Kikushige, Y., Miyawaki, K., Kunisaki, Y., Mizuno, S., Takenaka, K., ... Akashi, K. (2018). Dedifferentiation process driven by TGF-beta signaling enhances stem cell properties in human colorectal cancer. *Oncogene*, <https://doi.org/10.1038/s41388-018-0480-0>
- Nguyen, L. V., Vanner, R., Dirks, P., & Eaves, C. J. (2012). Cancer stem cells: An evolving concept. *Nature Reviews Cancer*, *12*(2), 133–143.
- Nimmakayala, R. K., Seshacharyulu, P., Lakshmanan, I., Rachagani, S., Chugh, S., Karmakar, S., ... Ponnusamy, M. P. (2018). Cigarette smoke induces stem cell features of pancreatic cancer cells via PAF1. *Gastroenterology*, *155*, 892–908.e6.
- Ooki, A., Dinalankara, W., Marchionni, L., Tsay, J. -C. J., Goparaju, C., Maleki, Z., ... Hoque, M. O. (2018). Epigenetically regulated PAX6 drives cancer cells toward a stem-like state via GLI-SOX2 signaling axis in lung adenocarcinoma. *Oncogene*, <https://doi.org/10.1038/s41388-018-0373-2>
- Pardal, R., Clarke, M. F., & Morrison, S. J. (2003). Applying the principles of stem-cell biology to cancer. *Nature Reviews Cancer*, *3*(12), 895–902.
- Qin, X.-Y., Suzuki, H., Honda, M., Okada, H., Kaneko, S., Inoue, I., ... Kanki, K. (2018). Prevention of hepatocellular carcinoma by targeting MYCN-positive liver cancer stem cells with acyclic retinoid. *Proceedings of the National Academy of Sciences of the United States of America*, *115*(19), 4969–4974.
- Rafael, D., Gener, P., Andrade, F., Seras-Franzoso, J., Montero, S., Fernández, Y., ... Videira, M. (2018). AKT2 siRNA delivery with amphiphilic-based polymeric micelles show efficacy against cancer stem cells. *Drug Delivery*, *25*(1), 961–972.
- Sainz, B., Martin, B., Tatar, M., Heesch, C., & Guerra, S. (2014). ISG15 is a critical microenvironmental factor for pancreatic cancer stem cells. *Cancer Research*, *74*, 7309–7320.
- Sainz B, Jr, Alcalá, S., García, E., Sánchez-Ripoll, Y., Azevedo, M. M., Cioffi, M., ... Heesch, C. (2015). Microenvironmental hCAP-18/LL-37 promotes pancreatic ductal adenocarcinoma by activating its cancer stem cell compartment. *Gut*, *64*, 1921–1925.
- Shah, D., Wyatt, D., Baker, A., Simms, P., Peiffer, D.S., Fernandez, M.L., ... Miele, L. (2015). Inhibition of HER2 enriches for JAGGED1-dependent breast cancer stem cells: role for membrane Jagged1. *Clinical Cancer Research*, *24*, 4566–4578.
- Shi, F., Li, M., Wang, J., Wu, D., Pan, M., Guo, M., & Dou, J. (2018). Induction of multiple myeloma cancer stem cell apoptosis using conjugated anti-ABC2 antibody with epirubicin-loaded microbubbles. *Stem Cell Research & Therapy*, *9*(1), 144.
- Shi, Y., Guryanova, O. A., Zhou, W., Liu, C., Huang, Z., Fang, X., ... Bao, S. (2018). Ibrutinib inactivates BMX-STAT3 in glioma stem cells to impair malignant growth and radioresistance. *Science Translational Medicine*, *10*(443), eaah6816.
- Shimokawa, M., Ohta, Y., Nishikori, S., Matano, M., Takano, A., Fujii, M., ... Sato, T. (2017). Visualization and targeting of LGR5+human colon cancer stem cells. *Nature*, *545*(7653), 187–192.
- Siriwon, N., Kim, Y. J., Siegler, E., Chen, X., Rohrs, J. A., Liu, Y., & Wang, P. (2018). CAR-T cells surface-engineered with drug-encapsulated nanoparticles can ameliorate intratumoral T-cell hypofunction. *Cancer Immunology Research*, *6*(7), 812–824.
- Su, S., Chen, J., Yao, H., Liu, J., Yu, S., Lao, L., ... Song, E. (2018). CD10+GPR77 +cancer-associated fibroblasts promote cancer formation and chemoresistance by sustaining cancer stemness. *Cell*, *172*(4), 841–856.
- Sui, X., Cai, J., Li, H., He, C., Zhou, C., Dong, Y., ... Zhang, Y. (2018). p53-dependent CD51 expression contributes to characteristics of cancer stem cells in prostate cancer. *Cell Death & Disease*, *9*, 523.
- Takebe, N., Harris, P. J., Warren, R. Q., & Ivy, S. P. (2011). Targeting cancer stem cells by inhibiting Wnt, Notch, and Hedgehog pathways. *Nature Reviews Clinical Oncology*, *8*(2), 97–106.
- Talukdar, S., Pradhan, A. K., Bhoopathi, P., Shen, X.-N., August, L.A., Windle, J.J., ... Das, S.K. (2018a). MDA-9/syntenin regulates protective autophagy in anoikis-resistant glioma stem cells. *Proceedings of the National Academy of Sciences of the United States of America*, *115*, 5768–5773.
- Talukdar, S., Pradhan, A. K., Bhoopathi, P., Shen, X.-N., August, L. A., Windle, J. J., ... Fisher, P. B. (2018b). Regulation of protective autophagy in anoikis-resistant glioma stem cells by SDCBP/MDA-9/syntenin. *Autophagy*, *14*, 1–2.
- Tzeng, H. T., Su, C. C., Chang, C. P., Lai, W. W., Su, W. C., & Wang, Y. C. (2018). Rab37 in lung cancer mediates exocytosis of soluble ST2 and thus skews macrophages towards tumor-suppressing phenotype. *International Journal of Cancer*, *143*, 1753–1763.
- Vescovi, A. L., Galli, R., & Reynolds, B. A. (2006). Brain tumour stem cells. *Nature Reviews Cancer*, *6*(6), 425–436.
- Visvader, J. E., & Lindeman, G. J. (2008). Cancer stem cells in solid tumours: Accumulating evidence and unresolved questions. *Nature Reviews Cancer*, *8*(10), 755–768.
- Wang, D., Fu, L., Sun, H., Guo, L., & DuBois, R. N. (2015). Prostaglandin E2 promotes colorectal cancer stem cell expansion and metastasis in mice. *Gastroenterology*, *149*(7), 1884–1895.
- Wu, C. X., Wang, X. Q., Chok, S. H., Man, K., Tsang, S. H. Y., Chan, A. C. Y., ... Cheung, T. T. (2018). Blocking CDK1/PDK1/β-Catenin signaling by CDK1 inhibitor RO3306 increased the efficacy of sorafenib treatment by targeting cancer stem cells in a preclinical model of hepatocellular carcinoma. *Theranostics*, *8*(14), 3737–3750.
- Xiang, T., Long, H., He, L., Han, X., Lin, K., Liang, Z., ... Zhu, B. (2015). Interleukin-17 produced by tumor microenvironment promotes self-renewal of CD133+cancer stem-like cells in ovarian cancer. *Oncogene*, *34*(2), 165–176.
- Yi, M., Li, J., Chen, S., Cai, J., Ban, Y., Peng, Q., ... Xiang, B. (2018). Emerging role of lipid metabolism alterations in cancer stem cells. *Journal of Experimental & Clinical Cancer Research*, *37*(1), 118.
- Yoshida, G. J. (2018). How to eliminate MYCN-positive hepatic cancer stem cells to prevent the recurrence? *Proceedings of the National Academy of Sciences of the United States of America*, *115*(28), E6388–E6389.
- Yun, X., Zhang, K., Wang, J., Pageni, R. P., Yang, L., Bonner, M., ... Raz, D. J. (2018). Targeting USP22 suppresses tumorigenicity and enhances cisplatin sensitivity through ALDH1A3 downregulation in cancer-initiating cells from lung adenocarcinoma. *Molecular Cancer Research*, *16*, 1161–1171.
- Zakaria, N., Mohd Yusoff, N., Zakaria, Z., Wiedera, D., & Yahaya, B. H. (2018). Inhibition of NF-κB signaling reduces the stemness characteristics of lung cancer stem cells. *Frontiers in Oncology*, *8*, 166.
- Zappasodi, R., Budhu, S., Hellmann, M. D., Postow, M. A., Senbabaoglu, Y., Manne, S., ... Wolchok, J. D. (2018). Non-conventional Inhibitory CD4 +Foxp3-PD-1hi T cells as a biomarker of immune checkpoint blockade activity. *Cancer Cell*, *33*(6), 1017–1032.
- Zhang, D., Tang, D. G., & Rycak, K. (2018). Cancer stem cells: Regulation programs, immunological properties and immunotherapy. *Seminars in Cancer Biology*, *52*, 94–106.
- Zhang, W., Zhao, J.-M., Lin, J., Hu, C.-Z., Zhang, W.-B., Yang, W.-L., ... Zhu, J. (2018). Adaptive fibrogenic reprogramming of osteosarcoma stem cells promotes metastatic growth. *Cell Reports*, *24*(5), 1266–1277.
- Zuo, Z.-Q., Chen, K.-G., Yu, X.-Y., Zhao, G., Shen, S., Cao, Z.-T., ... Wang, J. (2016). Promoting tumor penetration of nanoparticles for cancer stem cell therapy by TGF-β signaling pathway inhibition. *Biomaterials*, *82*, 48–59.

How to cite this article: Najafi M, Farhood B and Mortezaee K. Cancer stem cells (CSCs) in cancer progression and therapy. *J Cell Physiol*. 2018;1–15.

<https://doi.org/10.1002/jcp.27740>