

Experimental studies of energy characteristics of mixer with deformable camera

S Yu Lozovaya¹, N M Lozovoy¹, L V Ryadinskaya¹, I B Kostina², O N Satler², L V Logvinova² and E I Ziborova²

¹ Belgorod State Technological University named after V. G. Shukhov, 46, Kostyukov str., Belgorod, 308012, Russia

² Belgorod National Research University, 85, Pobed str., Belgorod, 308015, Russia

E-mail: lozwa@mail.ru

Abstract. Currently the development of new machine designs and methods of their engineering calculation is one of the most priority areas of construction industry. It allows one to carry out research at the stage of theoretical calculations in order to predict the expected result. One of the promising constructive solutions for economic profitability increase of mixing equipment is the use of deformable working chambers. The main feature of such working chamber is the ability to change its overall dimensions during its deformation, which allows obtaining a new mechanism of influence on the processed medium, using it as a working element. Thus, the main output parameter for any deformable working elements is the movement transferred to the particles of the materials being mixed. Output parameters that have a small effect on the value of particle displacement are the characteristics of the chamber such as the material (stiffness, elasticity in the presence of cording) and execution (shape, installation method, various design decisions). Various types of rubber can be used as the material for chamber making that depends on the required mixing conditions such as the degree, type and intensity of the chamber deformations, as well as the required quality of the final product. Simplicity of introducing mixers into existing technological lines should also be noted. That increases the economic efficiency for both large and small enterprises, focused on making a profit at minimal cost.

1. Introduction

Evaluation of the equipment use efficiency in relation to a specific technological process and to the processed materials requires experimental studies to determine the main technological and operational characteristics of the devices under study. At the first stage it is necessary to conduct evaluation tests with various combinations of parameters, to compare theoretical and experimental data and to determine the main factors that influence the process of material mixing and to choose the intervals for their variation. The second stage assumes experimental research with application of multifactorial planning. The results processing involves the use of a comprehensive research method [1], including system analysis; mathematical, physical modeling; methods of mathematical statistics and the use of computer engineering.

2. Experimental studies

In the devices being developed, the quality of the mixing process depends on the frequency of the effect on the elementary volumes of the components being mixed per unit time:



- under cramped conditions – on the intensity of the shell walls impact on the mixture;
- under free conditions – on the intensity of the shell walls impact on the mixture and on the free space volume in the working chamber [2].

The raise of the rolling castors force impact on the deformable chamber increases the intensity of the particles relocation in the material being mixed that can be achieved by external and internal forces (for example, using a corrugated body) [3].

The deformable working chamber in question has a cylindrical shape and is installed horizontally (under a slight inclination to 8°), while the body of the working chamber is rigidly fixed to the trunnions (Figure 1). The outer part of the body is tightly enfolded in the cross section by the clamps, which are spherical bodies rigidly fixed on the axis. The axis of the clamps, in turn, is installed in the support bearings. From the drive shaft, rotation is transmitted to the clamps. Rolling the body of the working chamber from the outside, they deform it periodically (with the frequency of the shaft rotation), thereby causing the mixing material to move. The efficiency of the material mixing process can be increased by raising the clamps rotation speed.

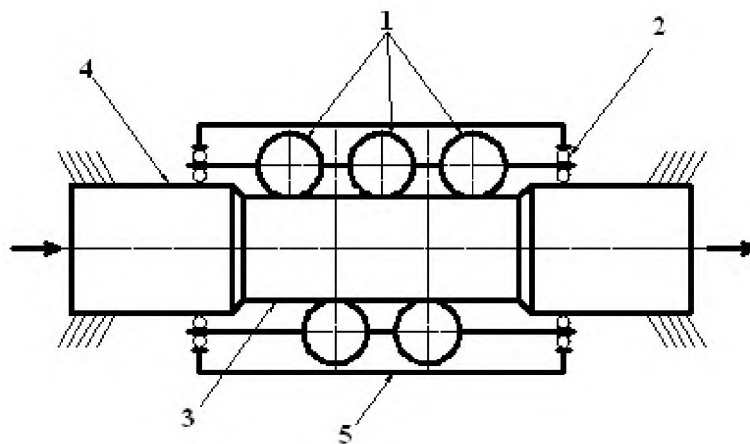

Figure 1. Diagram of cylindrical working chamber:
1 - clamps; 2 - supporting bearings; 3 - deformable cylindrical working chamber; 4 - pin; 5 – carrier.

Planning an experiment using mathematical methods makes researcher's work more ordered and generally increases its effectiveness. In order to obtain reliable results at each stage of the research, it is necessary to measure the results under identical conditions and with constant parameters and modes of material mixing [4].

Twelve experiments have been preliminary conducted at constant modes of material mixing. By the ratio $K_{ad}/K_{vcr} = 1.23$ for the mixing process with the reliability of the experimental results of 0.95, we set the required number of repetitions of each experiment equal to 3. The central composite rotational plan of the complete factor experiment is chosen as the main experiment design.

The polynomial of the second degree has the form:

$$y = \sum_{i=0}^3 a_i x_i + \sum_{i=2}^3 \sum_{j=2}^3 a_{ij} x_{ij} + \sum_{i=1}^3 a_i x_i^2 + \varepsilon_0, \quad (1)$$

where a_i, a_j - estimation of regression coefficients;

x_i, x_j - planning factors and their combinations;

ε - experiment error;

y - observed response of functional dependence.

The energy parameters in devices with deformable working chambers are affected by a sufficiently large number of factors:

$$P=f(n, L, D, K, K^3, \Delta, t), \quad (2)$$

where n – rotational speed of the drive;

D - working area diameter before deformation;

K - % mixture components ratio;

K_s - load density;

L – length of the working area;

Δ - deformation coefficient of the working area;

t - time of material processing.

The mathematical model of the process is the function connecting the optimization parameter P (the power consumed by material mixing) with variable factors (Table 2).

To simplify the mathematical planning of the experiments and to reduce the number of variable factors, it was found experimentally that the mixing process proceeds the more intensively, the greater the deformation coefficient of the grinding chamber is, but the maximum possible deformation of the body should not exceed 25% of the original chamber size. Otherwise, loss of its stability is observed [5].

The load density K is assumed to be maximum (the chamber is filled with material after deformation), since it ensures maximum performance. Cylindrical chambers with volume $V = 3$ l were used for the experiments (radius (R) was equal to 0.05 m and length (L) was equal to 0.2 m). The mixing time was assumed to be 7 minutes, as the best one for obtaining the required quality mixture for the proposed levels of the selected factors variation (Table 1).

The factor of changing chamber filling by material, similarly to the existing mixers, was equal to 0.75% (2.5 L) of the chamber volume (3 L). There is a problem of mixing the basic components of dry building mixtures with different physical and mechanical characteristics, and the mixing device is fundamentally new. So under the proposed conditions, for determining the working capacity of the device, sand was selected as the basic material with particle sizes of 1.25-2.5 mm; cement brand was 350. The ratio of mixture components varied within 90/10 -60/40%.

According to the evaluation tests, the mixing time is 3 min, the drive speed is 100 to 300 rpm (pivot rotation frequency is 10.5 to 31.5 s⁻¹), because less than 100 revolutions during a short mixing time led to the inhomogeneity factor of 60% and during 180 rpm during the maximum mixing time of 7 min, the inhomogeneity factor was 75.7%, which can be explained by the fact that the cement particle, compared to the sand particles, has a higher dispersion and under the action of centrifugal forces, sand particles are thrown to the chamber walls (separation into factions), conducting increase of mixture heterogeneity ratio.

Models have combinations of priority arguments that affect the process management of reducing the energy characteristics of mixing devices that can be used for research. To check the correctness of the mathematical models obtained, the following technological parameters were selected (Table 1).

Table 1. Intervals and levels of independent variables variation.

Variation levels	independent variables			
	<i>n</i> , rpm		<i>K</i> , % Mixture components ratio	
	Natural form	Coded form	Natural form	Coded form
Basic	400	0	75/25 (1225 kg/m ³)	0
Variation intervals	100	-	11/9 (45 kg/m ³)	-
Upper level	500	+1	66/34 (1270 kg/m ³)	+1
Lower level	300	-1	84/16 (1180 kg/m ³)	-1
Upper star point	650	1.682	60/40 (1300 kg/m ³)	1.682
Lower star point	150	-1.682	90/10 (1150 kg/m ³)	-1.682

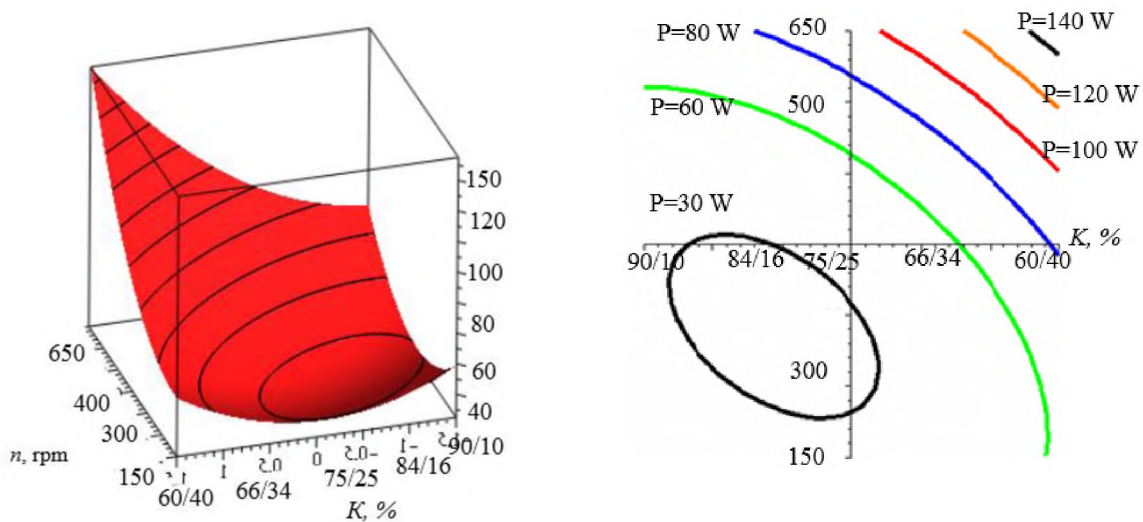

Figure 2. Grid of experimental studies of change in mixer power.

Based on the results of the experimental data (Table 2), the regression equations in the coded (3) and decoded (4) forms and their graphic interpretation (Figure 2) are obtained for cylindrical chambers:

$$P=34.8+9.6x_1-3.9x_2-x_1x_2+37.3x_{12}+34.3x_{22}; \quad (3)$$

$$P=1449-3n-171 K -0.005n K +0.004n_2+9 K_2. \quad (4)$$

The importance of factors for cylindrical chambers is $n=72\%$, $K=28\%$.

Table 2. Experimental results

	X_1	X_2	X_1^2	X_2^2	X_1X_2	Y_{av}, W	Y_{calc}, W	%
1	-1	-1	1	1	1	115	102.35	11
2	1	-1	1	1	-1	140	121.80	13
3	-1	1	1	1	-1	109	99.19	9
4	1	1	1	1	1	126	110.88	12
5	-1.682	0	2.829	0	0	117	108.81	7
6	1.682	0	2.829	0	0	170	146.20	14
7	0	-1.682	0	2.829	0	145	136.30	6
8	0	1.682	0	2.829	0	125	113.75	9
9	0	0	0	0	0	40	38.00	5

3. Results and discussion

The results of the experiment have shown that the most significant factors in the process of reducing the energy characteristics of a mixing device with a deformable chamber is the rotational speed of the drive. The dependence of the objective function on the weight or percentage ratio of the components of the mixture and the speed of the drive has the form of a parabola, which indicates the presence of the largest or smallest values for this function, i.e. we can talk about the existence of an optimal size of the investigated factors. The analysis of the graph (Figure 2) has shown that the power $P = 30$ W is achieved with the ratios of the mixture components varying in the range 90/10 (1150 kg/m³) - 75/25 (1225 kg/m³) and the drive speed of approximately 300 rpm that corresponds with theoretical investigations. It can also be seen that the minimum power value $P = 18$ W in the mixing device under consideration is achieved by varying the factors $K = 84/16\%$ (1180 kg/m³), $n = 300$ rpm. It is established that for mixing devices with a cylindrical chamber, when using in the materials being mixed, the percentage ratio of the considered factors is $K = 66/34\%$ (1270 kg/m³), a sharp increase in power values (8-15 times) is observed. Limitation of the weight values range or of the percentage ratios of the mixture components is explained by their close correspondence with the coefficient of chamber filling. Increasing the ratio of the components of the blended material reduces the distributability of the component with a small percentage, which requires a longer mixing time, and this leads to an increase in energy consumption.

The results of experimental studies of power variation for mixing devices with a deformable working chamber of a cylindrical shape confirm the data obtained theoretically. From the analysis it can be concluded that the selected factors influence the process of lowering the energy characteristics of the device under consideration, and the obtained dependencies allow determining the output parameters for any combination of arguments, thereby predicting the results of the process under study.

References

- [1] Braginsky Ln, Bogachev V I and Barabash V M 2009 *Mixing in liquid media The physical principles and engineering methods of calculating Chemistry* (Moscow: Chemistry) 336
- [2] Vasiltsov V A and Ushakov V G 2011 Apparatus for mixing liquid media (*Mechanical Engineering*) 271
- [3] Eremin N F 1986 *Processes and apparatus in the technology of building materials* (Moscow: Higher Education) 736
- [4] Uvarov V A and Lozovoy N M 2012 *Determination of forces in a mixer with a variable working chamber of periodic action (Vestnik Belgorod State Technological University named after V G Shukhov 1)* 56-59
- [5] Lozovaya S Yu, Lozovoy N M, Peshkov O V and Ryadinskaya L V 2017 *Theoretical basis for calculating the energy characteristics of a mixer with a deformable chamber of cylindrical shape (Fundamental research 10)* 245-250