

Hindawi Publishing Corporation
International Journal of Electrochemistry
Volume 2012, Article ID 216494, 7 pages
doi:10.1155/2012/216494

Research Article

Forced Air-Breathing PEMFC Stacks

K. S. Dhathathreyan, N. Rajalakshmi, K. Jayakumar, and S. Pandian

Centre for Fuel Cell Technology (ARCI), IIT Madras Research Park, 2nd Floor, 6 Kanagam Road, Taramani, Chennai 600 113, India

Correspondence should be addressed to N. Rajalakshmi, lakshmiraja2003@yahoo.com

Received 16 July 2012; Revised 24 July 2012; Accepted 25 July 2012

Academic Editor: Sheng S. Zhang

Copyright © 2012 K. S. Dhathathreyan et al. This is an open access article distributed under the Creative Commons Attribution License, which permits unrestricted use, distribution, and reproduction in any medium, provided the original work is properly cited.

Air-breathing fuel cells have a great potential as power sources for various electronic devices. They differ from conventional fuel cells in which the cells take up oxygen from ambient air by active or passive methods. The air flow occurs through the channels due to concentration and temperature gradient between the cell and the ambient conditions. However developing a stack is very difficult as the individual cell performance may not be uniform. In order to make such a system more realistic, an open-cathode forced air-breathing stacks were developed by making appropriate channel dimensions for the air flow for uniform performance in a stack. At CFCT-ARCI (Centre for Fuel Cell Technology-ARC International) we have developed forced air-breathing fuel cell stacks with varying capacity ranging from 50 watts to 1500 watts. The performance of the stack was analysed based on the air flow, humidity, stability, and so forth, The major advantage of the system is the reduced number of bipolar plates and thereby reduction in volume and weight. However, the thermal management is a challenge due to the non-availability of sufficient air flow to remove the heat from the system during continuous operation. These results will be discussed in this paper.

1. Introduction

The polymer electrolyte membrane fuel cells (PEMFCs) are a promising alternative to batteries as power supply in consumer electronics, sensors, and medical devices. For a successful integration of fuel cells into electrical appliances, the dimension of the fuel cell must be in accordance with the existing geometry of the device. In addition, the other main problem of PEMFCs resides in the miniaturization of auxiliary components that must be scaled down with the stack. External subsystems, such as the blower, humidification unit, and heat exchanger, increase the complexity for balance of the plant of the fuel cell system and typically have low efficiencies and power density when miniaturized. Air-breathing PEM fuel cells have recently been of great interests among fuel cell researchers and developers particularly for portable applications. Simplicity in the design of stack and peripheral units and advanced operating concepts of the air-breathing PEM fuel cells have a significant effect on the development of alternative power sources for the mobile electronics in terms of effective humidity control and substantially reduced parasitic loss. Running PEMFCs in free convection mode significantly reduce the number of

subsystems required. The direct control over the air stream in the PEMFC is very difficult to obtain, thereby making temperature and humidity control an important problem. In addition, air-breathing fuel cells consistently achieve lower performance than cells operated under forced convection mode. Many studies have been conducted on fuel cells running in free convection mode and conclusions are that in this operation mode, problems limiting performances are due to mass transport and water management [1, 2].

Compact PEM fuel cell system is extensively studied by many researchers in order to elucidate transient characteristics of air-breathed PEM fuel cells and evaluate its performance. The performance of an air-breathing fuel cell was evaluated under different environmental conditions by Chu and Jiang [3]. Jiang and Chu [4] adopted pseudo-bipolar plates in one of their 6 cell stacks and found that the cell performance was significantly affected by the environmental humidity. The effect of the various gas diffusion media and current collectors on PEM fuel cell performance was investigated by Hottinen et al. [5] and they observed that the thin gas diffusion media have less mass transport resistance leading to very high current densities. Noponen et al. [6] introduced a direct in situ measurement system to map the

current distribution in a free breathing PEM fuel cell system and showed experimental and computational results.

Schmitz et al. [7] studied the planar air-breathing cells and studied the influence of cathode opening size and wetting properties of diffusion layers on the performance. Schmitz et al. [8] applied the printed circuit technology to develop a new type of planar fuel cells consisting of an open cathode and then demonstrated a long-term operation more than 1500 h. Parametric studies for an 80 W stack by varying the relative humidity and the fan-blowing flow rate have been reported by Sohn et al. [9].

Understanding the cathode flooding and dryout for water management in air-breathing PEM fuel cells were studied by Paquin and Fr chet [10]. Mennola et al. [11] identified that the limiting problem was the system's inability to remove water for cell temperatures below 40°C. Modroukas et al. [12, 13] studied the utilization of a passive water control system based on hydrophilic material that enhances water removal from the cell and thereby increased the cell performance. O'Hayre et al. [14] studied in the temperatures ranging from 10 to 80°C and demonstrated the dependence of performance on humidification of the cell. At temperatures higher than 70°C, membrane dryout was found to be the limiting phenomenon. Morner and Klein [15] and Jeong et al. [16] also concluded that membrane humidity is one of the most significant factors in determining fuel cell performances in free convection mode and that the performances of air-breathing fuel cells are strongly dependant on water management. Ous and Arcoumanis [17] studied the formation of water droplets and their aggregation in the cathode flow channels by direct visualization under various operating conditions. The aggregation of water droplets in the channels was strongly influenced by the change in the air and hydrogen stoichiometry conditions.

Understanding the performance and the characteristics of PEMFC stacks is clearly important for realizing the optimum cost, weight, and performance ratios. The objective of this study is to construct a bridge between the development and applications of PEMFC stacks for promoting their practical applications in various markets. It is very difficult to achieve a good performance for air-breathing PEMFC by simply using the design rule for typical PEMFCs with a forced convection air channel. Rather, one must redesign each component of the fuel cell considering the special issues caused by the way of air supply in the cathode side. In the case of the cathode channel design, the channel configuration is generally complex and narrow in the typical forced convection air supply PEMFCs in order to achieve a practical pressure drop to drive out unwanted water and distribute gas in every cell and every section of channel uniformly. The serpentine flow field is frequently used in forced convection PEMFCs. The pressure drop is the most important parameter to scale the channel configuration in typical PEMFCs. However, in air-breathing PEMFCs with a vertical air channel, the channel configuration could be relatively simple and wide to induce more oxygen into the channel and strengthen mass and heat transfer. The mass transfer rate is vital parameter for designing the air channel. To optimize the channel configuration and to improve the

performance, it is necessary to build small air-breathing PEMFCs before scaling it up. By taking into account the above said challenges in air-breathing fuel cells, herein, we report air-breathing PEMFC stacks, which are built with a series of bicell units, having a feature of light weight and high power. The fuel is fed into the stack from compressed hydrogen cylinders and the oxidant and the coolant are fed by a single blower by active methods. The heat dissipation of the stack is realized efficiently and automatically because of large contact area designed between the stack surface and environmental air. These results are discussed here.

2. Experimental

The schematic of the experimental facility is shown in Figure 1. Air-breathing PEMFC stacks were built using bicells composed of 4 cells, 12, and 52 cells, in a series connection. The geometric area of each electrode is approximately 330 sq.cm. The air supply to the cathode was spontaneously supplied from an air blower which is also used to cool the stack. The flow field design used for forced air breathing is shown in Figure 2. The channel width and rib width are taken as 3 mm with a depth of 1.5 mm. High-purity hydrogen of 99.99% was used as fuel, from a compressed cylinder. An aalborg mass flow controller was used for measuring the hydrogen flow rate. A resistance-based DC Load box was used for dissipating the current and a multimeter was used for measuring the voltage. The MEAs are composed of Nafion 1135 membrane and proprietary gas diffusion layers from CFCT with Pt/C in the catalyst layer [18]. K type thermocouples were kept on the side and center of stack and inlet of air to monitor the temperature. Figure 3 shows the photograph of different forced air-breathing stacks. Experimental data are collected and logged by a Yokogawa MX100 data acquisition/switch unit.

3. Results and Discussion

The effects of all operating and control parameters on stack operation are investigated by the dynamic experimental tests and the data are analyzed to get a fundamental insight into forced air-breathing PEM fuel cell system. It is well known that the performance of PEMFCs is a function of temperature, humidity, and pressure. However, increasing the operating temperature leads to difficult thermal management and membrane dry-out problems. Operating pressure increase will result in the system complications.

In a traditional free breathing PEMFC, the cathode channels are open to ambient air from both ends. The term free breathing refers to the natural convection by which the oxygen needed by the cell reaction is transferred into the cell. Natural convection of air in the cathode channels is driven by buoyancy, which is caused by temperature and gas composition gradients. Temperature gradient is caused by the heat generated in cell reactions and losses and with possible external heating of the cell. Changes in gas composition are caused by the cathode reactions which consume oxygen and produce water.

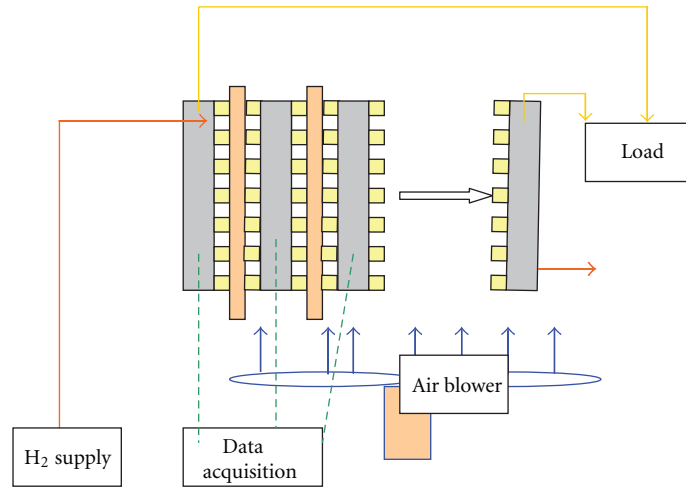

FIGURE 1: Schematic of stack and test apparatus.

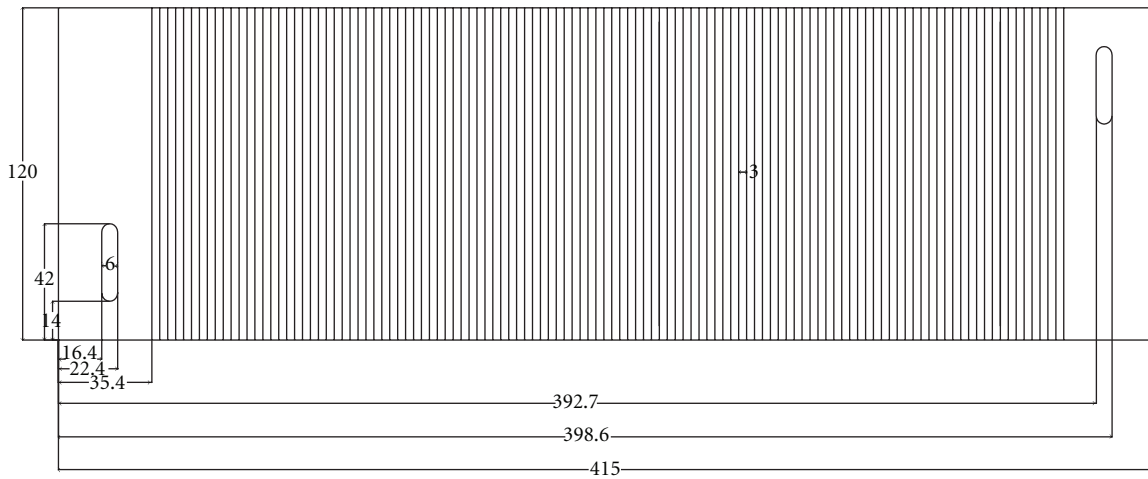

FIGURE 2: Flow field design for air supply/coolant.

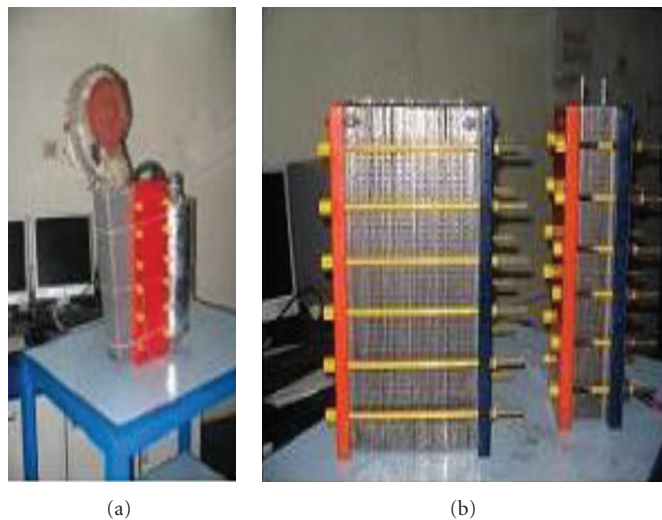

FIGURE 3: Photograph showing the forced-air breathing stacks.

The air-breathing PEMFC stack was designed to use oxygen from the forced air, which is simpler and lower cost than other types of stacks. The reaction product of water at the cathode electrodes was automatically exhausted to environment. The disadvantage is that any factors, which are present in surrounding environment, may affect the stack performance. The first factor considered is humidity of hydrogen gas. Initially a 4-cell stack was built and tested with hydrogen at various humidification temperatures and the performance is shown in Figure 4. The power output was found to vary between 40 to 55 watts based on the humidification temperature of 50 to 70°C. The increased performance with increasing temperature is attributed to both the increased reaction rate of the electrode process and the increased ionic conductivity of the membrane electrolyte.

The orientation of the stack also was tested by allowing the product water to drain in the vertical orientation or to allow the product water for self-humidification in the horizontal orientation. It was found that the horizontal orientation gives a better performance compared to vertical orientation as shown in Figure 5. The same stack was operated continuously and found that initially the stack performance increases upto 48 watts from 38 watts in 150 min and stabilized at 44 watts for almost 6 hours, delivering a constant power as shown in Figure 6. The initial increase, drop, and stabilization of power may be attributed to the performance increase due to high temperature kinetics, drying, and self-humidification, respectively. The temperature distribution across the stack was measured at various locations namely, near the H₂ inlet, outlet, and the middle of the stack and found that the outlet H₂ temperature is almost uniform compared to inlet and the middle as shown in Figure 7, revealing that the hydrogen humidification and cell temperature gets equilibrated near the outlet. In addition, the forced air supply to the stack was provided by two different units, namely, an instrument cooling fan and another high flow blower. The fan speed not only determines the air flow rates to the stack, but also prevents the stack from overheating, as high stack temperature would result in degradation of the Membrane Electrode Assemblies (MEAs). The auxiliary power requirement for these two units was found to be 3 watts and 12 watts, respectively.

From Figure 8, one can see that the stack performance also changes depending on the type of forced air supply. The airflow, and thus also the oxygen supply and the water removal, in the channels is proportional to the temperature difference between the cell and the surrounding air. This airflow transfers part of the generated heat from the cell to the surroundings. The rest is transferred by thermal radiation and convection from the surfaces of the cell. The radiative heat transfer is proportional to the difference between absolute cell temperature to fourth power and absolute ambient temperature. Thus, at a higher ambient temperature a smaller temperature difference is needed to provide the same radiative heat transfer rate. Depending on the ratio of different heat transfer mechanisms, there may be significant deviation in temperature difference between the cell and surroundings at varying ambient conditions resulting in nonsimilar airflow rates.

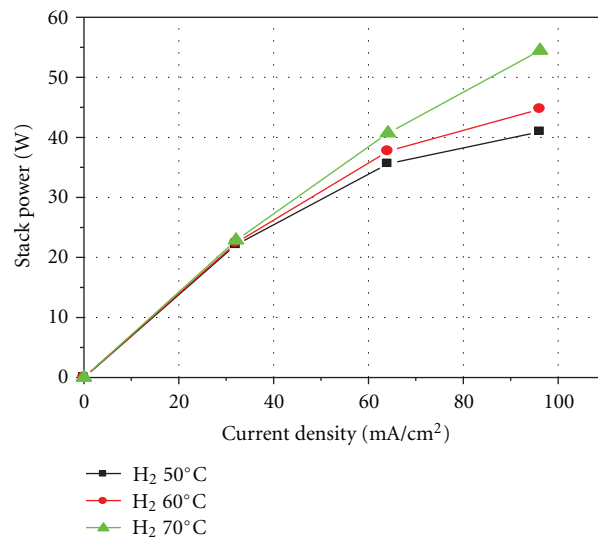

FIGURE 4: Fuel cell performance at different humidity.

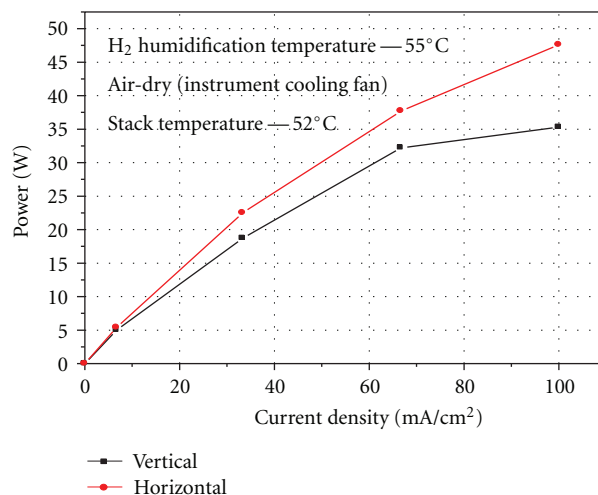

FIGURE 5: Fuel cell performance due to stack orientation.

The forced feed air supply PEMFC stack was designed for direct utilization of air from the surrounding. This will result in a simpler, lighter, cost competitive system than a traditional stack design. The product water at the cathode is automatically blown to the environment. The disadvantages are that any impurities present in the ambient air may poison and degrade the stack performance. In addition, the air humidity may also have a significant impact on the stack performance. The air humidity will change with weather conditions and it will be different on rainy and on sunny days. The ambient humidity and temperature were variable and chosen according to realistic weather conditions. Li et al. [19] have studied the performance of a forced air-breathing stack and compared it with air breathing and concluded that with the help of forced air to the fuel cell, the performance of fuel cell can be enhanced. The oxygen concentration in the electrode can be low due to three different reasons like diffusion media, due to low permeability, different parts of active area due to fuel cell reactions, and nonoptimal flow

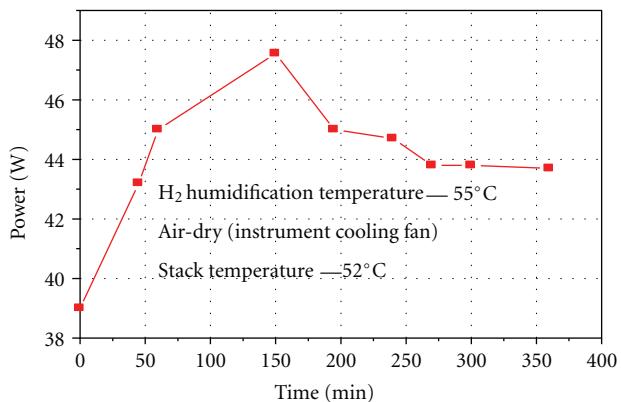

FIGURE 6: Stability of the stack performance.

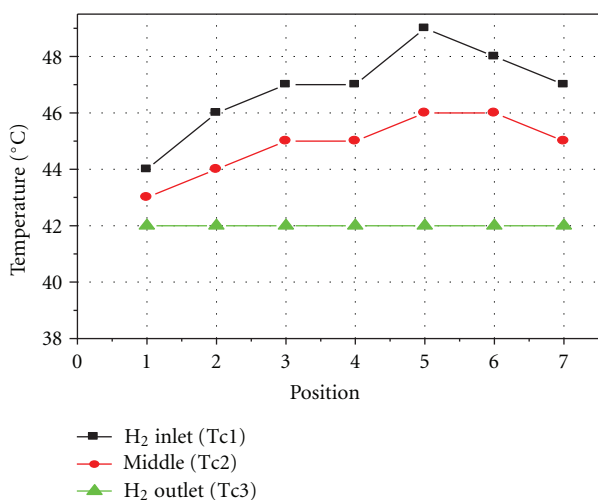

FIGURE 7: Temperature variation within the stack.

conditions and state of product water, especially if in liquid state, can reduce the porosity of gas diffusion layer and cover parts the catalyst surfaces resulting in spatially heterogeneous oxygen concentration.

The 12-cell forced air breathing stack was made out of one H₂ plate, one air plate, and 11 bipolar plates as shown in the schematic Figure 9. Similarly the 52 cells stack delivering a power of ~1.5 kW capacity was constructed using 52 cells with 53 plates consisting of bipolar plates and air and H₂ monopolar plate. The performance of an air-breathing polymer electrolyte membrane fuel cell (PEMFC) stack was evaluated under different environmental conditions. The humidity of the surrounding air significantly affected the performance of the stack. When the humidity was less than 10% RH at 35°C, the stack lost almost 95% power. It was observed that the acceptable operating temperature for the stack would be from 20 to 40°C for 50% RH.

The performance of a forced air-breathing stack of 500 watt capacity and 1500 watt capacity is shown in Figures 10 and 11, respectively, with respect to voltage and current. From the polarization curve shown in Figure 10, one can see that the voltage starting from 11.5 volts decreased to 6.5

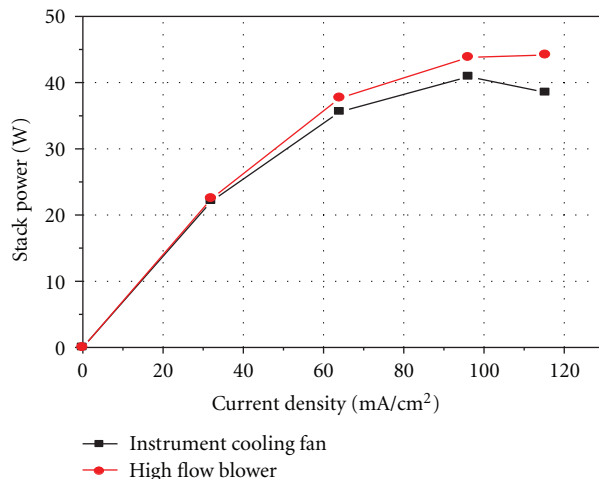

FIGURE 8: Fuel cell performance due to different air-moving device.

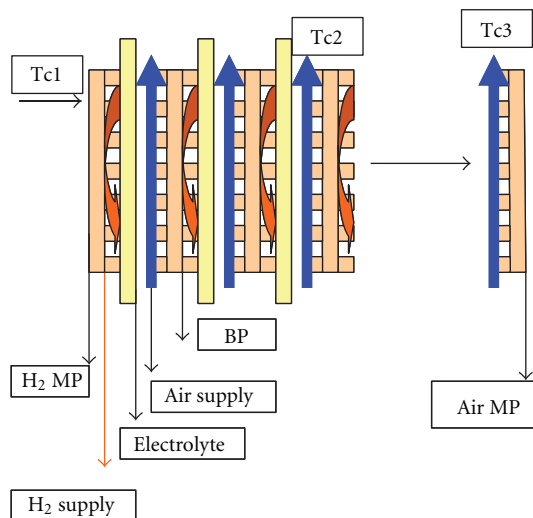

FIGURE 9: Schematic of fuel cell stack assembly.

volts when we draw current density upto 225 mA/sq cm. The electrical power delivered from the stack was found to be 450 watts. At the low current density the electrochemical process is mainly controlled by a charge transfer reaction or activation of the electrodes. At the high-current density the electrochemical process is mainly controlled by ohmic and/or mass transfer polarization. However, in a 1500 watt stack as shown in Figure 11, the current density was only 150 mA/sq cm at 0.58 V. The drop in current density from 500 watt to 1500 watt stack is mainly due to the imbalance of heat and water management. Further work is in progress to address the above mentioned issues.

4. Conclusion

In the present paper we have studied three different capacities of air-breathing stacks and the effect of humidity, temperature, air flow rate, on the performance is reported. The humidity in the surrounding air significantly affects

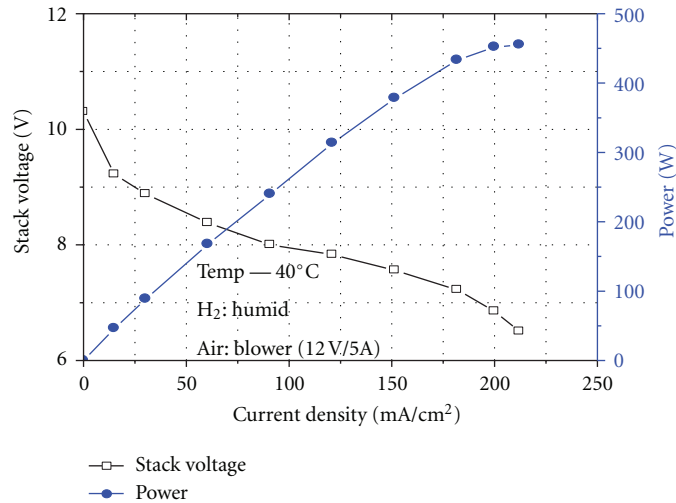

FIGURE 10: 500 watt fuel cell performance curve.

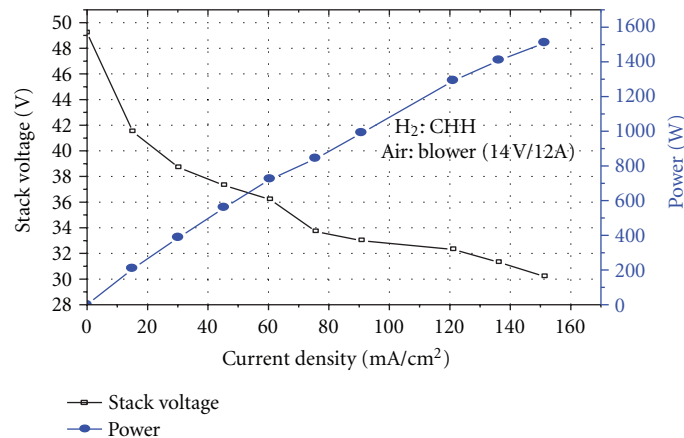

FIGURE 11: 1.5 kW fuel cell performance curve.

the performance of the air-breathing PEMFC stack. The operation temperatures for the air-breathing PEMFC stack would be from 50 to 70°C. For higher air flow rate and humidity, the stack performance was found to be higher and much stable. The concept of forced-feed air-supply PEMFC stack without much parasitic power has been developed and verified. The environmental humidity, temperature, and air flow rate are found to be the major determinants for efficient operation of the air-breathing PEMFC stack.

Acknowledgments

The authors would like to acknowledge Dr. G. Sundararajan, Director, ARCI, for his constant support and encouragement. The authors also acknowledge the financial support from DST, Government of India, New Delhi.

References

- [1] K. S. Dhathathreyan and N. Rajalakshmi, *Recent Trends in Fuel Cell Science and Technology*, Edited by S. Basu, Anamaya, 2007.
- [2] N. Rajalakshmi and K. S. Dhathathreyan, *Progress in Fuel Cell Research*, Nova, 2008.
- [3] D. Chu and R. Jiang, "Performance of polymer electrolyte membrane fuel cell (PEMFC) stacks—part I. Evaluation and simulation of an air-breathing PEMFC stack," *Journal of Power Sources*, vol. 83, no. 1-2, pp. 128–133, 1999.
- [4] R. Jiang and D. Chu, "Stack design and performance of polymer electrolyte membrane fuel cells," *Journal of Power Sources*, vol. 93, no. 1-2, pp. 25–31, 2001.
- [5] T. Hottinen, O. Himanen, and P. Lund, "Effect of cathode structure on planar free-breathing PEMFC," *Journal of Power Sources*, vol. 138, no. 1-2, pp. 205–210, 2004.
- [6] M. Noponen, T. Mennola, M. Mikkola, T. Hottinen, and P. Lund, "Measurement of current distribution in a free-breathing PEMFC," *Journal of Power Sources*, vol. 106, no. 1-2, pp. 304–312, 2002.
- [7] A. Schmitz, M. Tranitz, S. Eccarius, A. Weil, and C. Hebling, "Influence of cathode opening size and wetting properties of diffusion layers on the performance of air-breathing PEMFCs," *Journal of Power Sources*, vol. 154, no. 2, pp. 437–447, 2006.

- [8] A. Schmitz, M. Tranitz, S. Wagner, R. Hahn, and C. Hebling, "Planar self-breathing fuel cells," *Journal of Power Sources*, vol. 118, no. 1-2, pp. 162–171, 2003.
- [9] Y. J. Sohn, G. G. Park, S. D. Yim et al., "The operating characteristics in an air-breathing PEMFC," in *Proceedings of the 3rd International Conference on Fuel Cell Science, Engineering, and Technology*, pp. 239–244, Ypsilanti, Mich, USA, May 2005.
- [10] M. Paquin and L. G. Fréchette, "Understanding cathode flooding and dry-out for water management in air breathing PEM fuel cells," *Journal of Power Sources*, vol. 180, no. 1, pp. 440–451, 2008.
- [11] T. Mennola, M. Noponen, M. Aronniemi et al., "Mass transport in the cathode of a free-breathing polymer electrolyte membrane fuel cell," *Journal of Applied Electrochemistry*, vol. 33, no. 11, pp. 979–987, 2003.
- [12] D. Modroukas, *Mass transport studies in conventional and microfabricated free convection proton exchange membrane fuel cells [Ph.D. thesis]*, Dept. of Mechanical Engineering, Columbia University, 2006.
- [13] D. Modroukas, V. Modi, and L. G. Frechette, "Micromachined silicon structures for free-convection PEM fuel cells," *Journal of Micromechanics and Microengineering*, vol. 15, no. 9, pp. 193–201, 2005.
- [14] R. O'Hayre, T. Fabian, S. Litster, F. B. Prinz, and J. G. Santiago, "Engineering model of a passive planar air breathing fuel cell cathode," *Journal of Power Sources*, vol. 167, no. 1, pp. 118–129, 2007.
- [15] S. O. Morner and S. A. Klein, "Experimental evaluation of the dynamic behavior of an air-breathing fuel cell stack," *Journal of Solar Energy Engineering, Transactions of the ASME*, vol. 123, no. 3, pp. 225–231, 2001.
- [16] S. U. Jeong, E. A. Cho, H. J. Kim, T. H. Lim, I. H. Oh, and S. H. Kim, "Effects of cathode open area and relative humidity on the performance of air-breathing polymer electrolyte membrane fuel cells," *Journal of Power Sources*, vol. 158, no. 1, pp. 348–353, 2006.
- [17] T. Ous and C. Arcoumanis, "The formation of water droplets in an air-breathing PEMFC," *International Journal of Hydrogen Energy*, vol. 34, no. 8, pp. 3476–3487, 2009.
- [18] N. Rajalakshmi, H. Ryu, and K. S. Dhathathreyan, "Platinum catalysed membranes for proton exchange membrane fuel cells - higher performance," *Chemical Engineering Journal*, vol. 102, no. 3, pp. 241–247, 2004.
- [19] P. W. Li, T. Zhang, Q. M. Wang, L. Schaefer, and M. K. Chyu, "The performance of PEM fuel cells fed with oxygen through the free-convection mode," *Journal of Power Sources*, vol. 114, no. 1, pp. 63–69, 2003.



Hindawi

Submit your manuscripts at
<http://www.hindawi.com>

