

Research Article

Area-Based Approach in Power Quality Assessment

Surajit Chattopadhyay,¹ Samarjit Sengupta,² and Madhuchhanda Mitra²

¹ Electrical Engineering Department, Hooghly Engineering and Technology College, Hooghly, West Bengal 712103, India

² Department of Applied Physics, University of Calcutta, 92 Acharya Prafulla Chandra Road, Kolkata 700009, India

Correspondence should be addressed to Surajit Chattopadhyay, surajit_2004@indiatimes.com

Received 28 May 2007; Revised 10 March 2008; Accepted 11 May 2008

Recommended by Subhashish Bhattacharya

This paper presents an approach for assessment of power quality parameters using analysis of fundamental and harmonic voltage and current waveforms. Park transformation technique has been utilized for the analysis in three-phase system, which has reduced the computational effort to a great extent. Contributions of fundamental and harmonic components in power system voltage and current signals have been assessed separately. An algorithm has been developed to calculate the power quality parameters from online signals. This algorithm has been simulated for a radial system, and the results have been compared with that obtained from a standard FFT-based system. The results are seen to be in good agreement with that of the standard system.

Copyright © 2008 Surajit Chattopadhyay et al. This is an open access article distributed under the Creative Commons Attribution License, which permits unrestricted use, distribution, and reproduction in any medium, provided the original work is properly cited.

1. INTRODUCTION

Quality of electric power refers to maintaining the near sinusoidal waveform of power distribution bus voltages and currents at rated magnitude and frequency. The causes of poor quality of power have nowadays been identified broadly as follows: (i) actual loads, equipment, and linear and nonlinear components and (ii) subsystems of transmission and distribution systems causing impulses, notches, voltage sag and swell, voltage and current unbalances, momentary interruption, and harmonic distortions. The other major contributors to poor power quality are harmonics and reactive power circulated by power circuit controllers in a power system.

Researches are going on for long to study the effects of unbalance and harmonics on power quality in a power system [1–3]. In a nonsinusoidal and unbalanced environment, some practical definitions have also been suggested [4–6]. A new approach for designing power acceptability curve has been proposed [7]. In such conditions, measurement and monitoring of power quality in respect of its unbalance and harmonics have been presented in different publications [8–13], and different modern mathematical tools have also been utilized to estimate the unbalance in power in a system [14, 15]. There are several existing methods for the detection of the current harmonics like fast Fourier transform (FFT), instantaneous p - q theory, synchronous d - q reference theory, analog or digital filters, and so forth [16]. In some cases, passive filters are also used, but they are having

the drawbacks of bulky components, fixed compensated characteristics, sensitivity to line impedance, and series and parallel resonance with system.

In this paper, an area-based approach has been proposed to assess electric power quality in a three-phase power system. Harmonics-free system voltages $v(t)$ or currents $i(t)$ form a closed loop in voltage-voltage or current-current plane. In this loop, cleavages appear with the presence of harmonics, order of which is directly proportional to number of cleavages. An algorithm has been developed using area-based approach to calculate active power, reactive power, and total harmonic distortion factors. Park transformation technique has been used for three-phase power distortion factor measurement, which has reduced the computational effort to a great extent. The developed technique has been simulated showing good agreement to results of standard techniques.

2. ASSESSMENT OF PREDOMINANT HARMONIC

In a three-phase system, voltages and current waveform can be expressed as

$$[V_{R,Y,B}] = \begin{bmatrix} \sum_{n=1,2,3,\dots,n_V} V_{Rn} \sin(n\omega t - \varphi_{Rn}) \\ \sum_{n=1,2,3,\dots,n_V} V_{Yn} \sin(n\omega t - 2\pi/3 - \varphi_{Yn}) \\ \sum_{n=1,2,3,\dots,n_V} V_{Bn} \sin(n\omega t - 4\pi/3 - \varphi_{Bn}) \end{bmatrix},$$

$$[I_{R,Y,B}] = \begin{bmatrix} \sum_{n=1,2,3,\dots} I_{Rn} \sin(n\omega t - \theta_{Rn}) \\ \sum_{n=1,2,3,\dots} I_{Yn} \sin(n\omega t - 2\pi/3 - \theta_{Yn}) \\ \sum_{n=1,2,3,\dots} I_{Bn} \sin(n\omega t - 4\pi/3 - \theta_{Bn}) \end{bmatrix}. \quad (1)$$

These phase voltages and line currents are transformed into d - q reference frame using well-known Park transformation matrix [16, 17] as follows:

$$\begin{aligned} [V_{d,q,0}] &= \begin{bmatrix} v_d \\ v_q \\ v_0 \end{bmatrix} = [\text{Park Matrix}] \times [V_{R,Y,B}], \\ [I_{d,q,0}] &= \begin{bmatrix} I_d \\ I_q \\ I_0 \end{bmatrix} = [\text{Park Matrix}] \times [I_{R,Y,B}]. \end{aligned} \quad (2)$$

In d - q plane, voltages and currents form closed loops in which the presence of harmonics brings cleavages (minima) as shown in Figure 1. The loop shown in this figure is created by the waves having 5th order of harmonics and has 4 cleavages. Table 1 gives the relation between the number of cleavages and highest order of predominant harmonic. The number of cleavages (minima) increases with the increase of order of highest harmonic [17]. It concludes that the highest order (n_H) is equal to the number of cleavages plus one, that is,

$$n_H = C + 1. \quad (3)$$

3. PRINCIPLE OF AREA-BASED APPROACH

3.1. Real and imaginary parts

If voltage and current waveform are plotted in v - i plane, then the area covered in one cycle is given by

$$A_{\text{TOTAL}}^{v-i} = \int v di = k_1 \sum_n n V_n I_n \sin \phi_n, \quad (4)$$

where, $\phi_n = \varphi_n - \theta_n$, and $k_1 = 0.1\omega$.

Similarly, in vi - t plane, the area covered by voltages and currents in one cycle is given by

$$A_{\text{TOTAL}}^{vi-t} = \int vidt = k_2 \sum_n V_n I_n \cos \phi_n, \quad (5)$$

where, $\phi_n = \varphi_n - \theta_n$, and k_2 is a constant.

Equations (4) and (5) indicate that A_{TOTAL}^{v-i} contains the information of real part of power, and A_{TOTAL}^{vi-t} contains the information of imaginary or reactive part of power. Also, it is noted that only harmonic components of the same order have contributions in the areas.

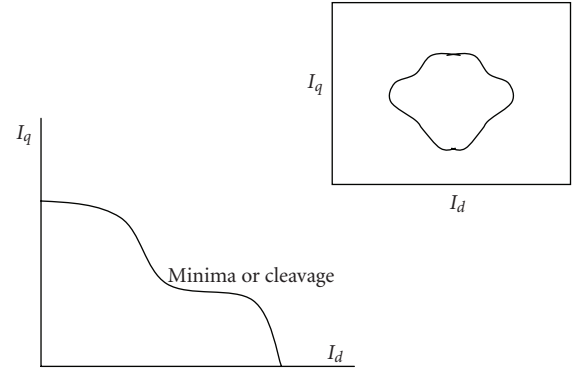

FIGURE 1: Loop formed by I_d and I_q of three-phase system containing fifth harmonic.

TABLE 1: Table for number of cleavage (C) and order of highest harmonics (n_H).

n_H	1	2	3	5	7	13
C	0	1	2	4	6	12

3.2. Introduction of reference signal

If any one of the voltage or current signal from a power system is available, then, its real and imaginary parts can be separated by plotting the signal with a known reference signal. General form of such a signal is defined as

$$R(t) = \sin n\omega_1 t = \sin n 2\pi f_1 t. \quad (6)$$

Here, f_1 is fundamental frequency of the reference signal. f_1 should be equal to the fundamental frequency f of the voltage and current signals collected from the power system, which is initially an unknown quantity. f_1 is taken equal to 50 Hz, the standard power frequency. Then, the reference signal is plotted with any one of voltage and current signals. If the loop formed in this plotting is closed one then the fundamental frequency is confirmed as 50 Hz. Otherwise, the loop will be open, that is, there will be a finite gap between the starting and ending point as shown in Figure 2. Then, f_1 is set as $(50 \pm \Delta f)$, where, Δf is a small incremental value. Δf is to be adjusted so that starting and ending point meet each other. The frequency corresponding to this loop is taken as the fundamental frequency of the voltage and current waveform collected from the power system. Then, the reference signal is modified as

$$R(t) = \sin n 2\pi f t. \quad (7)$$

3.3. Assessment of harmonic component

The above reference signal is plotted with voltage and current signals, respectively, to find real and imaginary parts as discussed in Section 3.1. Contribution of fundamental component is assessed taking $n = 1$ in the reference signal. For harmonic assessment, maximum limit of n is taken as n_H as observed from (4).

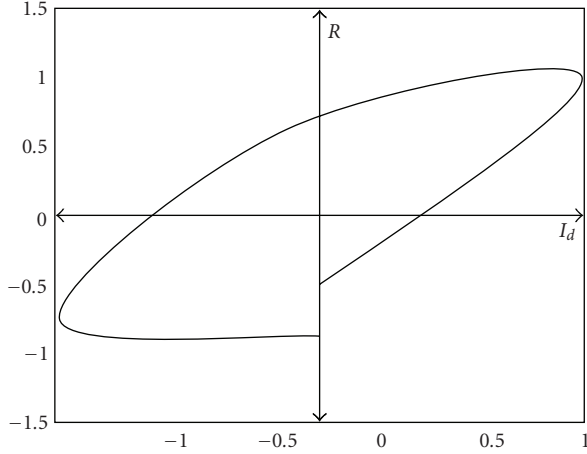

FIGURE 2: Curves formed by R and I_d having unequal fundamental frequency.

Along d -axis, amplitudes and phase angles for n th order of voltage and current harmonic component are derived as

$$\begin{aligned} V_{dn} &= \sqrt{(K_1 A_{dn}^{v_d-R})^2 + (K_2 A_{dn}^{v_dR-t})^2}, \\ \varphi_{dm} &= \tan^{-1} \left(\frac{K_1 A_{dm}^{v_d-R}}{K_2 A_{dm}^{v_dR-t}} \right), \\ I_{dn} &= \sqrt{(K_1 A_{dn}^{i_d-R})^2 + (K_2 A_{dn}^{i_dR-t})^2}, \\ \theta_{dn} &= \tan^{-1} \left(\frac{K_1 A_{dn}^{i_d-R}}{K_2 A_{dn}^{i_dR-t}} \right). \end{aligned} \quad (8)$$

As in active and reactive power only, harmonics components of same order contribute as discussed in Section 3.1, using (8), reactive and active power contributed by n th order of voltage and current harmonics are written as

$$\begin{aligned} Q_{dn} &= \frac{1}{2} V_{dn} I_{dn} \sin(\varphi_{dn} - \theta_{dn}), \\ P_{dn} &= \frac{1}{2} V_{dn} I_{dn} \cos(\varphi_{dn} - \theta_{dn}). \end{aligned} \quad (9)$$

Similarly, along q -axis, amplitudes and phase angles for n th of voltage and current component are derived as

$$\begin{aligned} V_{qn} &= \sqrt{(K_1 A_{qn}^{v_q-R})^2 + (K_2 A_{qn}^{v_qR-t})^2}, \\ \varphi_{qm} &= \tan^{-1} \left(\frac{K_1 A_{qm}^{v_q-R}}{K_2 A_{qm}^{v_qR-t}} \right), \\ i_{qn} &= \sqrt{(K_1 A_{qn}^{i_q-R})^2 + (K_2 A_{qn}^{i_qR-t})^2}, \\ \theta_{qn} &= \tan^{-1} \left(\frac{K_1 A_{qn}^{i_q-R}}{K_2 A_{qn}^{i_qR-t}} \right). \end{aligned} \quad (10)$$

Using (10), reactive and active power contributed by n th order of voltage and current harmonics are written as

$$\begin{aligned} Q_{qn} &= \frac{1}{2} V_{qn} I_{qn} \sin(\varphi_{qn} - \theta_{qn}), \\ P_{qn} &= \frac{1}{2} V_{qn} I_{qn} \cos(\varphi_{qn} - \theta_{qn}). \end{aligned} \quad (11)$$

4. POWER QUALITY PARAMETERS

4.1. Active power distortion factor

Active power distortion factor is defined as the ratio of active power contributed by harmonic components to that contributed by fundamental component and is given by

$$\text{PDF} = \frac{P_H}{P_1} = \frac{\sum_n (P_{dn} + P_{qn})}{P_1}. \quad (12)$$

4.2. Reactive power distortion factor

Reactive power distortion factor is defined as the ratio of reactive power contributed by harmonic components to that contributed by fundamental component and is given by

$$\text{QDF} = \frac{Q_H}{Q_1} = \frac{\sum_n (Q_{dn} + Q_{qn})}{Q_{d1} + Q_{q1}}. \quad (13)$$

4.3. Total power

Total power is given by

$$S = P + jQ = \sum_n (P_{dn} + P_{qn}) + j \sum_n (Q_{dn} + Q_{qn}). \quad (14)$$

4.4. Total harmonic distortion factors

Total harmonic distortion of voltage along d -axis is given by

$$\text{THD}_{dV} = \frac{\sqrt{\sum_n V_{dn}^2}}{V_{d1}}. \quad (15)$$

Total harmonic distortion of voltage along q -axis is given by

$$\text{THD}_{qV} = \frac{\sqrt{\sum_n V_{qn}^2}}{V_{q1}}. \quad (16)$$

Total harmonic distortion of current along d -axis is given by

$$\text{THD}_{dI} = \frac{\sqrt{\sum_n I_{dn}^2}}{I_{d1}}. \quad (17)$$

Total harmonic distortion of current along q -axis is given by

$$\text{THD}_{qI} = \frac{\sqrt{\sum_n I_{qn}^2}}{I_{q1}}. \quad (18)$$

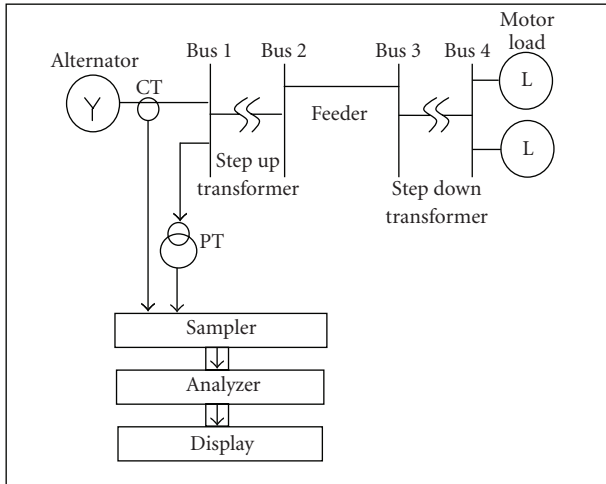

FIGURE 3: Schematic diagram of simulated network.

5. COMPUTER SIMULATION

5.1. Simulated network

A three-phase radial power system having motor and static load has been simulated in MATLAB as shown in Figure 3. Voltage at bus 1 and current drawn from the alternator are observed in the alternator bus. Voltage signal is stepped down using potential transformer, and current signal is stepped down using current transformer. These signals are then sampled using a sampling unit. The sampled data are digitized and taken into consideration to form loops.

5.2. Algorithm

The analyzer works obeying an algorithm developed based on the principles discussed in Sections 3 and 4. The algorithm has been explained with the help of a flow diagram shown in Figure 4. First fundamental frequency is determined. Then, reference signal is set, and different loops are to be formed. Areas are calculated to assess fundamental as well as harmonic components. After this active power, reactive power and apparent power are calculated.

5.3. Results

Different distortion factors are calculated using above algorithm. The result is designated as calculated value. The same data are assessed using Fourier analysis, and the result is designated as true value. The true value is compared with the calculated value. The error has been calculated, and satisfactory results containing low error have been achieved. Sample results in measurement of active power distortion, reactive power distortion, and total harmonic distortion are presented in Tables 2, 3, and 4. Error decreases with the increase of the sampling rate of the sampler.

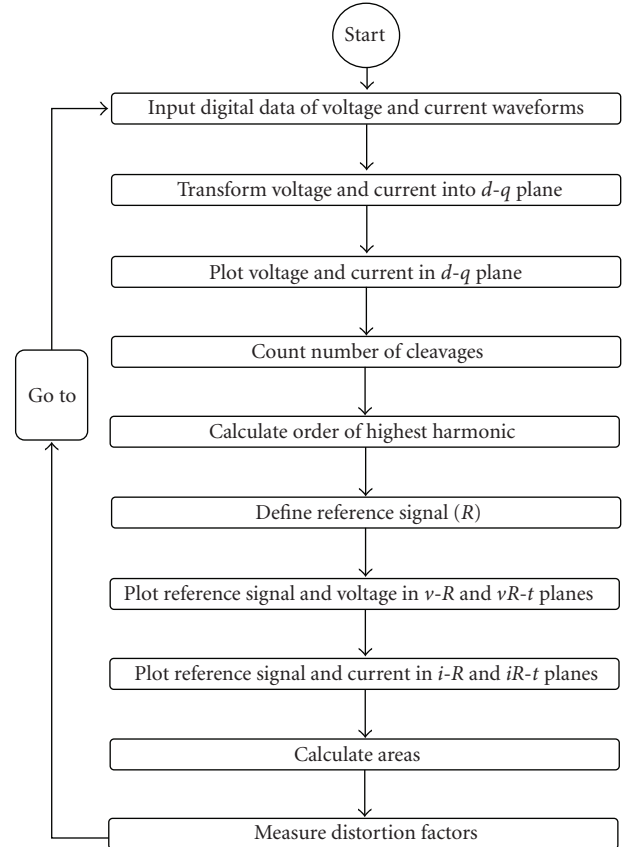

FIGURE 4: Flow diagram for analyzer.

TABLE 2

PDF _{True}	PDF _{Calculated}	ERROR
0.1246	0.1247	0.0001
0.1284	0.1284	0.0000
0.1422	0.1423	0.0001
0.2350	0.2350	0.0000
0.3530	0.3532	0.0002

TABLE 3

QDF _{True}	QDF _{Calculated}	ERROR
1.1662	1.1664	0.0002
1.2042	1.2041	0.0001
1.4200	1.4200	0.0000
1.5667	1.5668	0.0001
1.1600	1.1600	0.0000

TABLE 4

THD _{d-True}	THD _{d-Calculated}	ERROR
0.1242	0.1242	0.0000
0.2024	0.2025	0.0001
0.3032	0.3028	0.0002
0.1998	0.1999	0.0001
0.3600	0.3602	0.0002

6. CONCLUSIONS

Power quality parameters have been assessed using analysis of fundamental and harmonic voltage and current waveforms. Instead of using three line currents and three-phase voltages, use of d - and q -axis currents and voltages reduces the number of variable to four (V_d , V_q , I_d , and I_q) from six (V_R , V_Y , V_B , I_R , I_Y , and I_B). Hence, it decreases the executing time and memory space required for the analysis. Thus, Park transformation technique, in three-phase system, has reduced the computational effort to a great extent. The same approach can be applied for quality assessment of each individual phase. In such cases, Park transformation will not be required and will again reduce the computational effort. An algorithm has been developed to calculate the power quality parameters from the online signals to assess contributions of fundamental and harmonic components in power system voltage and current signals separately. The results obtained from simulated network using the algorithm have been compared with that obtained using a standard FFT-based technique. The results are seen to be in good agreement with that of the standard way. Small error speaks of the acceptability of the above area-based approach.

LIST OF SYMBOLS AND ABBREVIATIONS

N :	Order of current harmonics
n_H :	Order of highest harmonics
φ_m :	Phase angle of voltage of harmonics of order m
θ_n :	Phase angle of current of harmonics of order n
$A_{dm}^{v_d-R}$:	Area covered by curve v_d and Rv_m waveforms in v_d - R
$A_{dm}^{v_dR-t}$:	Area formed by curve in v_dR - t plane
$A_{dn}^{i_d-R}$:	Area covered by curve in i_d - R plane
$A_{dn}^{i_dR-t}$:	Area formed by curve in i_dR - t plane
$A_{qm}^{v_q-R}$:	Area formed by curve in v_q - R plane
$A_{qm}^{v_qR-t}$:	Area formed by curve in v_qR - t plane
$A_{qn}^{i_q-R}$:	Area formed by curve in i_q - R plane
$A_{qn}^{i_qR-t}$:	Area formed by curve in i_qR - t plane
Q_{dn} :	Reactive power contributed by harmonic component with frequency of order n along d axis
Q_{qn} :	Reactive power contributed by harmonic component with frequency of order n along q axis
Q_H :	Total reactive power contributed by harmonic components
Q_1 :	Total reactive power contributed by fundamental component
QDF:	Reactive power distortion factor
P_{dn} :	Active power contributed by harmonic component with frequency of order n along d axis
P_{qn} :	Active power contributed by harmonic component with frequency of order n along q axis
PDF:	Active power distortion factor
THD $_{dV}$:	Along d -axis total harmonic distortion of voltage
THD $_{qV}$:	Along q -axis total harmonic distortion of voltage

THD $_{dI}$: Along d -axis total harmonic distortion of current
 THD $_{qI}$: Along q -axis total harmonic distortion of current
 THD $_{YV}$: Total harmonic distortion factor for voltage in phase Y
 THD $_{YI}$: Total harmonic distortion factor for current in phase Y .

REFERENCES

- [1] A. Domijan, J. T. Heydt, A. P. S. Meliopoulos, M. S. S. Venkata, and S. West, "Directions of research on electric power quality," *IEEE Transaction on Power Delivery*, vol. 8, no. 1, pp. 429–436, 1993.
- [2] P. P. Barker, J. J. Burke, R. T. Mancao, et al., "Power quality monitoring of a distribution system," *IEEE Transaction on Power Delivery*, vol. 9, no. 2, pp. 1136–1142, 1994.
- [3] D. D. Sabin, D. L. Brooks, and A. Sundaram, "Indices for assessing harmonics distortion from power quality measurement: definitions and benchmark data," *IEEE Transaction on Power Delivery*, vol. 14, no. 2, pp. 489–496, 1999.
- [4] S. H. Jaramillo, G. T. Heydt, and E. O'Neill-Carrillo, "Power quality indices for aperiodic voltages and currents," *IEEE Transaction on Power Delivery*, vol. 15, no. 2, pp. 784–790, 2000.
- [5] A. M. Gaouda, M. M. A. Salama, M. R. Sultan, and A. Y. Chikhani, "Power quality detection and classification using wavelet-multiresolution signal decomposition," *IEEE Transaction on Power Delivery*, vol. 14, no. 4, pp. 1469–1476, 1999.
- [6] S. Santoso, E. J. Powers, W. M. Grady, and A. C. Parsons, "Power quality disturbance waveform recognition using wavelet-based neural classifier. I. Theoretical foundation," *IEEE Transactions on Power Delivery*, vol. 15, no. 1, pp. 222–228, 2000.
- [7] S. Santoso, E. J. Powers, W. M. Grady, and A. C. Parsons, "Power quality disturbance waveform recognition using wavelet-based neural classifier. II. Application," *IEEE Transactions on Power Delivery*, vol. 15, no. 1, pp. 229–235, 2000.
- [8] S. Santoso, W. M. Grady, E. J. Powers, J. Lamoree, and S. C. Bhatt, "Characterization of distribution power quality events with Fourier and wavelet transforms," *IEEE Transactions on Power Delivery*, vol. 15, no. 1, pp. 247–254, 2000.
- [9] A. Cavallini, G. C. Montanari, and M. Cacciari, "Stochastic evaluation of harmonics at network buses," *IEEE Transactions on Power Delivery*, vol. 10, no. 3, pp. 1606–1613, 1995.
- [10] S. Leva, A. P. Moronado, and D. Zaninelli, "Evaluation of the line voltage drops in presence of unbalance, harmonics and inter-harmonics: theory and applications," *IEEE Transaction on Power Delivery*, vol. 20, no. 1, pp. 390–396, 2005.
- [11] M. Karimi-Ghartemani and M. R. Iravani, "Measurement of harmonic/inter-harmonics of time varying frequencies," *IEEE Transaction on Power Delivery*, vol. 20, no. 1, pp. 23–31, 2005.
- [12] R. Carbone, F. De Rosa, R. Langella, and A. Testa, "A new approach for the computation of harmonics and interharmonics produced by line-commutated AC/DC/AC converters," *IEEE Transactions on Power Delivery*, vol. 20, no. 3, pp. 2227–2234, 2005.
- [13] A. Ferrero and G. Superti-Furga, "A new approach to the definition of power components in three-phase systems under nonsinusoidal conditions," *IEEE Transactions on Instrumentation and Measurement*, vol. 40, no. 3, pp. 568–577, 1991.
- [14] H. Akagi and A. Nabae, "The p - q theory in three-phase systems under non-sinusoidal conditions," *European Transactions on Electrical Power Engineering*, vol. 3, no. 1, pp. 27–31, 1993.

- [15] S. Leva and A. Paolo Morando, "Waves and complex power in transmission lines," *IEEE Transactions on Power Delivery*, vol. 18, no. 4, pp. 1320–1327, 2003.
- [16] A. Ferrero, A. P. Morando, R. Ottoboni, G. Superti-Furga, and J. L. Willems, "On the meaning of the park power components in three-phase systems under non-sinusoidal conditions," *European Transactions on Electrical Power Engineering*, vol. 3, no. 1, pp. 33–43, 1993.
- [17] S. Chattopadhyay, M. Mitra, and S. Sengupta, "Power quality analysis in park plane," in *Best of Book Volume on Modeling and Simulation*, pp. 8–16, AMSE, Lyon, France, 2006.



Hindawi

Submit your manuscripts at
<http://www.hindawi.com>

